

# International Journal of Research and Analytical Reviews

UGC Approved Research Journal

Periodicity - Quarterly



Atman Publishing Academy



International Journal of Research and Analytical Reviews

Atman Publishing Academy

2061-C/2/B, Nr. Adhyatma Vidya Mandir, Sanskar Mandal, Bhavnagar-364002.

Contact : 9427903033 E mail : [editorsijrar@gmail.com](mailto:editorsijrar@gmail.com), [ijrar1@gmail.com](mailto:ijrar1@gmail.com)



# International Journal of Research and Analytical Reviews

ijrar.com

© IJRAR - All rights reserved. Reproduction in any form is strictly prohibited.  
**This work is licenced under Creative Commons International Licence Attribution 4.0 E-version.**

Rs. 900

Subscription	1 year	2 years	5 years
Individual	3,000	6,000	15,000
Institutional	4,000	8,000	40,000
Advertisement	1000/Black	3000/colour	Per Page

**Send your Paper(s)/Article(s) and Contact us on any one of following**

**E mail: (1) [editorsijrar@gmail.com](mailto:editorsijrar@gmail.com) (2) [ijrar1@gmail.com](mailto:ijrar1@gmail.com) (3) [drbjoshi@ijrar.com](mailto:drbjoshi@ijrar.com)**

**Contact No.: +91 9427903033**

1. Thoughts, language vision and example in published research paper are entirely of author of research paper. It is not necessary that both editor and editorial board are satisfied by the research paper. The responsibility of the matter of research paper/article is entirely of author.
2. Editing of the IJRAR is processed without any remittance. The selection and publication is done after recommendations of at least two subject expert referees.
3. In any condition if any National/International University denies accepting the research paper/article published in IJRAR, than it is not the responsibility of Editor, Publisher and Management.
4. Only the first author is entitle to receive the copies of all co-author.
5. Before re-use of published research paper in any manner, it is compulsory to take written permission from the Editor – IJRAR, unless it will be assumed as disobedience of copyright rules.
6. All the legal undertakings related to IJRAR is subject to Bhavnagar Jurisdiction.

---

**Editor**

**International Journal of Research and Analytical Reviews**

Atman Publishing Academy

2061-C/2/B, Nr. Adhyatma Vidya Mandir, Sanskar Mandal, Bhavnagar-364002.

Contact : 9427903033 E mail : [editorsijrar@gmail.com](mailto:editorsijrar@gmail.com), [ijrar1@gmail.com](mailto:ijrar1@gmail.com)

**Editor in chief****Dr. R. B. Joshi****Senior Advisory Board**

<b>Dr. H. O. Joshi</b> Retd. Prof. & Head, Department of Education, Saurashtra University, Rajkot, Gujarat.	<b>Dr. Bhavesh Joshi</b> Associate Professor College of Food Processing Technology & Bioenergy, Agricultural University, Anand – 388110, Gujarat	<b>Vasantkumar Pathak</b> Director, Pathak Group of Schools & College, Rajkot.
---	---	---

**Editorial Board**

<b>Prof. (Dr.) Ami Upadhyay</b> Director, Department of Humanities And Social Sciences, Dr. Babasaheb Ambedkar Uni. A'Bad.	<b>Dr. Awa Shukla</b> Asst. Professor & Director, Social Sciences Dept. Babasaheb Ambedkar Open University, Ahmedabad.	<b>Dr. Dushyant Nimavat</b> Associate Professor Department of English, Gujarat University, Gujarat, India
<b>Dr. A. Heidari</b> Faculty of Chemistry California South University (CSU) Irvine, California, U. S. A.	<b>Dr. Bharat Ramanuj</b> Professor & Head, Department of Education, Saurashtra University, Rajkot.	<b>Dr. Nahla Mohammed Abd El-Aziz</b> Assistant professor - Entomology Department, Faculty of Science Cairo University, <b>Egypt.</b>
<b>Dr. Manahar Thaker</b> Principal G. H. Sanghavi college of Education, Bhavnagar, Gujarat.	<b>Dr. K. S. Meenakshisundaram</b> Director, C. A. A., Great Lakes Institute of Management, Chennai	<b>Dr. J. D. Dave</b> I/c Principal P.D. Malviya Graduate Teachers' College, Rajkot, Gujarat.
<b>Dr. M. B. Gaijan</b> Associate Professor, Shamaldas Arts College, Bhavnagar.	<b>Dr. A. K. Lodi</b> H.O.D. Faculty of Education, Integral University, Lucknow(UP)	<b>Dr. Trupti Pathak</b> Assistant Vice President(Tech.) Claris life Sciences, Ahmedabad. Gujarat.
<b>Dr. K. Ramadevi</b> Associate Professor Department of Civil Engineering Kumaraguru College of Technology, Coimbatore, Tamilnadu.	<b>Dr. Jayant Vyas</b> Professor & Head, Department of Education, M. K. Bhavnagar University, Bhavnagar	<b>Dr. Dilip D. Bhatt</b> Associate Prof. & Head, Department of English, V. D. K. Arts college, Savarkundla, Gujarat.
<b>K. S. Dave</b> Lecturer J. H. Bhalodia Women's College Rajkot, Gujarat.	<b>Dr. Anil Ambasana</b> Retd. Prof. & Head, Department of Education, Saurashtra University, Rajkot. Gujarat.	<b>Dr. Sandeep R. Sirsat</b> Associate Professor & Head, Department of Computer Science, Shri Shivaji Science & Arts College, Chikhli, Dist: Buldana (M.S.-India)

## Review Committee

### Editor & Head of Review Committee

**Dr. S. Chelliah**

Professor & Head,

Dept. of English and Comparative Literature,  
Madurai Kamraj University, Madurai-21, **India.**

<p><b>Mr. Zeeshan Shah</b> Senior Lecturer, Department of Multimedia and Communication, University College of Bahrain, <b>Kingdom of Bahrain.</b></p>	<p><b>Dr. Samira Shahbazi</b> Plant Protection &amp; Biotechnology Research Group, Nuclear Agricultural Research School, Nuclear Science &amp; Technology Research Institute (NSTRI), <b>Iran</b></p>	<p><b>Dr. Belal Mahmoud Al-Wadi</b> Lecturer, University of Dammam (Saudi Arabia), Founder &amp; Vice President of the Jordanian Society for Business Entrepreneurship <b>(Jordan)</b></p>
<p><b>Harish Mahuvakar</b> Associate Professor &amp; Head, Dept. of English, Sir P. P. Institute of Science, Bhavnagar, Gujarat, <b>India.</b></p>	<p><b>Dr. Mainu Devi</b> Assistant Professor (Sr. Grade) in Zoology, Diphu Govt. college, Karbi Anglong – Assam <b>India.</b></p>	<p><b>Asim Gokhan YETGIN</b> Assistant Professor, Faculty of Engineering, Dumlupinar University, Kutahya, <b>Turkey.</b></p>
<p><b>Dr. A. Kusuma</b> Assistant Professor, Department of Social Work, Vikramasimhapuri University, Nellore.(AP)</p>	<p><b>Prof. Rajeshkumar N. Joshi</b> I/C Dean, Faculty of Arts &amp; Humanities, C. U. Shah University, Gujarat, <b>India.</b></p>	<p><b>Sunita. B. Nimavat</b> Assistant Professor of English, N.P.College of Computer &amp; Mgt., Kadi (North Gujarat).</p>
<p><b>Nahla Mohammed Abdelazez</b> Assistant Professor Faculty of Science, Cairo University, Giza Governorate, <b>Egypt.</b></p>	<p><b>Dr. Riyad Awad</b> Associate professor, Structural Engineering, An - Najah National University, Nablus, <b>Palestine.</b></p>	<p><b>Dr. Amer A. Taqa</b> Professor Dept. of Dental Basic Science, College of Dentistry, Mosul University, Masul, <b>Iraq.</b></p>



# **Research Conference on IoT, Cloud and Data Science '19**

(5 & 6, April 2019)

Organized by



# **SRM**

**INSTITUTE OF SCIENCE & TECHNOLOGY**  
*(Deemed to be University u/s 3 of UGC Act, 1956)*

---

# **RCICD 2019**

---

## ABOUT THE CONFERENCE

One of the most significant characteristics of the evolving digital age is the convergence of technologies that includes sensors (internet of things: IoT), data storage (cloud), information management (databases), data collection (big data), data applications (analytics), knowledge discovery (data science), algorithms (machine learning), transparency (open data) and API services (micro services, containerization). We can find the human interaction with technology explicitly among the latest developments in digital marketing, behavioral analytics, user experience, customer experience, design thinking, cognitive computing, and social analytics. Research Conference on IoT, Cloud and Data Science - RCICD' 19 aims to bring together researchers from industry, Academicians, Business Delegates, scholars and graduate students to exchange and share their experiences, new ideas, and research results across aspects of IoT, Cloud and Data Sciences. The conference focuses on promoting recent advances and innovation in the field of IoT, Cloud and Data Science.

## About SRM Institute of Science and Technology

SRM Institute of Science and Technology (formerly known as SRM University) is one of the top ranking Universities and most premier engineering destinations in India, which was established in 1985 by the Founder Chancellor, Dr. T.R. Paarivendhar, SRM Institute of Science and Technology and now it is functioning in four campuses located at Kattankulathur, Vadapalani and Ramapuram in Tamil Nadu , the fourth campus at Modi Nagar, Ghaziabad and the fifth campus at Amaravathi, Andhra Pradesh with over 38,000 students and 2,600 faculty members. It offers a wide range of programs to students applying for undergraduate, post-graduate and doctoral programs in Engineering, Management, Medicine & Health Sciences, Law and Science amp&; Humanities. SRM Institute of Science and Technology has been engaged in nurturing minds through a rich heritage of academic excellence. Essentially a hub of bustling student activities, the green and beautiful campus has been a second-home to thousands of students in their journey to pursue higher education. The Institution has moved up through international alliances and collaborative initiatives to achieve global excellence. SRM Institute of Science and Technology's International Advisory Board (IAB) is actively involved in building a stronger international dimension in research and teaching methodology, which creates avenues for research and successful careers. The SRM Institute of Science and Technology also collaborates with foreign Universities like MIT, Carnegie Mellon University (CMU), Pittsburg University etc. offering a postgraduate academic program MSIT-ESE.

---

# International Journal of Research and Analytical Reviews

---

## Conference Committee

### Chief Patrons

Dr. T. R. Paarivendhar,  
Chancellor, SRM Institute of Science and Technology  
Mr. Ravi Pacha Moothoo,  
Chairman, SRM Institute of Science and Technology  
Dr. P. Sathyanarayanan,  
President, SRM Institute of Science and Technology.

### Patrons

Dr. T.P. Ganesan,  
Pro-VC (P&D), SRM Institute of Science and Technology  
Dr. N. Sethuraman,  
Registrar, SRM Institute of Science and Technology  
Dr. C. Muthamizhchelvan,  
Director (E&T), SRM Institute of Science and Technology  
Mr. J. Chandrakumar, IAS (Retd.),  
Director - Admin, SRM Institute of Science and Technology  
Dr. K. Duraivelu,  
Dean (E&T), SRM Institute of Science and Technology (Vadapalani Campus)

### Convener

Dr. S. Prasanna Devi,  
Professor and Head, Department of CSE,  
SRM Institute of Science and Technology

### Co-convener

Dr. J. Arun Nehru,  
Assistant Professor, Department of CSE,  
SRM Institute of Science and Technology

### Organising Secretaries

Dr. G. Paavai Anand,  
Assistant Professor, Department of CSE, SRMIST  
Dr. P. Mohamed Fathimal,  
Assistant Professor, Department of CSE, SRMIST

### Venue:

**SRM Institute of Science and Technology**  
Vadapalani Campus  
Faculty of Engineering and Technology,  
Department of Computer Science and Engineering  
#1, Jawaharlal Nehru Salai,  
100 Feet Road, Vadapalani,  
Chennai - 600026,  
Tamilnadu, India

Website : <http://www.rcicd.com>

---

## Contents

- 1 **A Cloud Based Attribute Access Policy Using Blockchain** 1 - 7  
Mrs. K Meenakshi, R Shrinikethan, R Vishal Eshwar, Yash Parekh
  - 2 **Secure And Open Cloud with De-Duplication Using HMAC Algorithm** 8 - 14  
Mrs. K Meenakshi, D Kiran , D Pramod Reddy and U Gokula Kannan
  - 3 **Enhanced Cloud Storage Security using Data Slicing and Hybrid Cryptography** 15 - 21  
Sidharth Sridhar, Arun Muralidharan, Mohammed Ashik and Vidhyasagar BS
  - 4 **Recommender System and Stock to Profit Possibility System Using Swarm Intelligence in E-Commerce** 22 - 26  
Shubham B Kumbhar
  - 5 **Improving Search Efficiency of Multi Keywords Over Encrypted Data Using Cloud Based Search Techniques** 27 - 33  
K Varun, C Srinivas, Reddy Jay Sudheer, Mrs. K Karthikayani
  - 6 **Cloud Computing Security Threats and Challenges** 34 - 41  
N Saravana Kumar, K Keerthana, Dr.V Dhanakoti
  - 7 **IOT Based Smart Charger Using Wifi Micro-Chip** 42 - 49  
S Manohar (AP), Arunkumar S, Manikandan P, J Vishal Karthick
  - 8 **Comprehensive Assistance for Visually Challenged Persons** 50 - 54  
Y Sriharsha , K Akshaya , V Shravan kumar , D Ashok
  - 9 **Data Framework for Small-Scale Provincial Farmers** 55 - 59  
D Elanthazhai, S Vishnupriya, Prince Niroshan, T Malathi
  - 10 **Emotion Detection Using Video Frames** 60 - 65  
S Sanarker, Raj Shekhar, Mrs Lakshmi
  - 11 **IOT Based Intelligent Stroke Prediction and Monitoring System** 66 - 72  
V. Akila (A.P), Navin MV, Mani Arasu D, Yogesh S
  - 12 **A Biometric Based User Authentication and Key Agreement Protocol for Internet Integrated Wireless Sensor Networks** 73 - 76  
AK Suntheya and Dr. R Geetha
  - 13 **Conversion of Neutral Speech to Emotional Speech using GMM-Based Techniques** 77 - 82  
KL Shreya Narasimhan, Sharon Sengole Rayan, TG Narayanan, S Niveditha
-

# International Journal of Research and Analytical Reviews

---

- 14 **A Novel Approach To Manage The Maintenance Cost And Electricity Consumption In Cloud Data Centers** 83 - 88  
M Rajavel, Noeline Lincy Jeba PS, Deepa S
- 15 **Design and Implementation of Smart Safety Device Using Arduino Micro Controller** 89 - 93  
R Hemalatha, P Nanthitha, M Rajavel
- 16 **Efficient Testing of Web Applications Using Action Based Keywords** 94 - 100  
Mrs. R Adline Freeda, Mrs. Krithikaa Venket, Mr. N Bhaskar
- 17 **Implementation of Fleet Management System using Wireless OBD II** 101 - 108  
Ms AishwaryaJeggan,Ms Akshaya N,Ms Myuri N,Mr KPK Devan
- 18 **Paper on Accident Detection System using License Plate Identification** 109 - 113  
Jervin R, Lavanya M, Keshav S, Gokul kumar K, S Latha Bhuvaneshwari
- 19 **Crop Yield Prediction with Minimum Expenditure for Proper Production using Random Forest Algorithm** 114 - 118  
Neelesh Kumar, Shreya Joshi, Nandkishore P, Vinit K
- 20 **Computing Minimum Support Price to Promote Agriculture as A Sustainable Model** 119 - 125  
R Nitin, R Ramasubramanian, Shriya Suresh, KPK Devan
- 21 **Application of Growing Neural Gas as A Validation Function** 126 - 132  
Shreyas Keelary, S Jeyendra, CB Ajay Vishaal, Saket Suman, Dr. G Paavai Anand
- 22 **Fractional Ownership in Agriculture using Blockchain** 133 - 137  
Dhanyakumar Baid, Gurkeerat Singh, Nikhil Raj and K Meenakshi
- 23 **Prediction of Heart Valve Disorders using CNN and DTW Based CBR** 138 - 143  
Aarthi K
- 24 **Privacy Protection for P2P Decentralized Network Using Blockchain For Data Privacy by Implementing Multiple Databases** 144 - 149  
K Meenakshi, Arun Prasad K, Vivek Subramaniam, Prasad Durga
- 25 **Sentiment Analysis on 2019 Indian election using unsupervised learning on Twitter data** 150 - 155  
M Rangan, M Poonkodi, S Vijayakumar, S Aravind
- 26 **A Productive DDoS TCP Surge Assault Identification and Aversion Framework in a Cloud** 156 - 159  
K. Karthikayani, Milan patel, Rudra Dev, G karthik
- 27 **Connecting with Music** 160 - 167  
Sathya Priya VK, Harish Keerthivasan V, Aashika R, Ashok D
-

# International Journal of Research and Analytical Reviews

---

- 28 **Enhancement of Generative Adversarial Network for Image Generation** 168 - 173  
V Yaswanth Sai Kumar, B Kesavaragavan, GSRS Akhil, M Akash, D Punitha
- 29 **Build and Analysis of Question and Answering System** 174 - 180  
B Subhashini, Kavipriya R, Harish P, BS Vidhyasagar
- 30 **Using Machine Learning for Web Application Development** 181 - 185  
Sreekari D, Ashwath, Vinit
- 31 **Vehicle Accident and Anti-Theft Tracking System Based on Internet of Things** 186 - 189  
S Mownica, P Annceline, R Ramya, M Indumathy
- 32 **An Efficient Optical Communication Technique Using Mimo and OFDM Along With Generalized LED Index Modulation** 190 - 197  
S. Priyadharshini
- 33 **Cost Estimation and Analysis Tool for C Programming** 198 - 205  
Ram Kumar, Gautam Shetty, Kaushik Kamal Das
- 34 **Companion Chatbot** 206 - 211  
Harsh Agrawal, Arup Patel, Aditya Bhosale, G.Paavai Anand
- 



# SRM

INSTITUTE OF SCIENCE & TECHNOLOGY  
(Deemed to be University u/s 3 of UGC Act, 1956)

---

# RCICD 2019

---



## A Cloud Based Attribute Access Policy Using Blockchain

Mrs. K Meenakshi, R Shrinikethan, R Vishal Eshwar, Yash Parekh

Dept. of Computer Science & Engineering.

SRM Institute of Science & Technology,

Chennai, Tamilnadu, India

**ABSTRACT:** *As of late, distributed storage frameworks have turned into a prominent-methods for information stockpiling and partaking in a wide range of utilization situations. Different Cloud Storage System permits various clients to alter similar records at the same time. Along these lines, a few issues on access controls may rise. There can be difficulties in how to disperse information to guarantee that flexibility necessities are met under different unforeseen conditions. From this paper, we are going to present a mode which is a multi-client framework for accessing the datasets that will put away in a doubtful condition in the cloud. Our methodology gives an entrance control Access that has the control which is commonly an approach or strategy that permits, denies or confines access to a framework. It is intended to make decentralized administrations dependent on the square chain and uses the Attribute-based Access Control System. This System enables us to design approval that tends to numerous factors. We make an approach by setting an accumulation of access control qualities that we partner with a particular client passage or session. It at that point applies that strategy record to the client passage or session. This type of access control is done using the Dynamic Access Policy. For each record the client makes a shrewd contract; It stores data about the proprietor, get to approach, a hash whole of the put-away data, data to recognize the cloud and all progressions that will happen with the document. We propose by upgrading a lot of conventions which is guaranteeing protection of some tasks they are Delegation of Attribute Authority, decentralizing of qualities, Interference of attributes, which records the exchange of data so that an audit trail is given which shows where the asset/data comes from and every stop it has made on the journey of the transaction. This recorded exchange information can check the validness of resources and forbid trickery. The model of our framework is executed on the Ethereum blockchain organize.*

**Keywords:** *Attribute Based Access Control Policy, Block-chain, Cloud Storage*

### 1. Introduction

Over the most recent couple of years, associations to store far away and adjust client information on cloud associations which have expanded. Associations that deal with uncommon data and authorized advancement, for instance, programming engineers, business visionaries, new organizations, and pharmaceutical associations need to control who comes into their workplaces, just as which areas they are allowed to access and they require broad limit frameworks in order to suit that data. An immense measure of clients Stores their records in mists. Everything considered, there are a few security issues and copyright point. The basic issue is exchanging information to the outside condition, with a definitive target that some other individual other than the proprietor can get acceptance to data. Trade accounts can end up being logically clear while using Distributed structures. Since in this kind of passed on record, all framework individuals share undefined documentation from negated to particular copies. That common version must be invigorated through accord, which suggests everyone must agree on it. To change a singular trade record would require the alteration of each and every subsequent record and the interest of the entire framework. Thus, data on this record is continuously exact, unflinching and clear than when it is pushed through paper-considerable systems. Then again, it is hard to regard the diverse work environments that offer associations to information gathering: fortress records, the capacity to get to their documents from any contraption from wherever on the planet, essential exchange of reports to different clients. You can discover several different ways to deal with manage the issue of secure remote document gathering. Regardless, the best of them is to scramble information before sending. Encryption is one of the basic monitored sections proposed by the cloud storage association. Regardless, the security that controls unquestionable which bother to use the information similarly, the completely given out access to them.

Whatever remains of the paper is composed as pursues. In Section 2 we examine Literature review. At that point in section 3, we depict the idea of the venture Existing framework and its hindrances. Further, in section 4 the proposed framework and its fundamental preferences and the chose plan of characteristic based encryption and adjusting it. In Section 5 we discuss the comparison of an existing and proposed system. In Section 6 finishes up the investigation and recognizes a couple of bearings of further research.



## II. Literature Survey

The framework utilizes the BlockDS technique that uses a decentralized off-chain disseminated hashtable (DHT) that is open through the blockchain, which stores references to the information yet not simply the information. DHTs have been generally used to arrange and keep up metadata about distributed frameworks. Kademlia is a well-known DHT that permits productive query through enormous systems, low coordination overhead, and protection from different assaults by leaning toward extensive nodes [1]. In Recent occasions, The Cloud stockpiling frameworks have turned into a prominent-methods for information stockpiling and partaking in a wide range of utilization situations. Different Cloud Storage System permits various clients to alter similar reports at the same time. Accordingly, a few issues on access controls may emerge [2]. According to this paper, we see that the storing data and share with an arrangement for the decentralized limit structure & motive a structure which joins the redistributed collecting framework, the blockchain system & Attributes based system which is an advancement. In this structure, the information proprietor can stream conundrum key for information clients and scramble shared information by showing access game-plan, and the course of action accomplishes fine-grained find the opportunity to arrange over data [3]. In the progressing years, there is a huge amount of growth in IoT which contraptions and has actuated a revived output for the security and assurance answer for shared data and clients. Thusly, in that way, the Blockchain advancement has ascended as a contender for secure trade-based correspondences. This system will allow good flexibility of gigantic business trades in IOT and which will address each memory essential out of that the issue to store the squares and some specific methods are Hyperledger Testbed Setup, TPS Observations, Block Weight and Ledger Scalability Analysis [4]. The Evolution of blockchain is one of the front-line progressions that uses cryptographically executed scattered record system, its security appraisal is critical to ensure its supportiveness in dispersed registering space. We by especially that demonstrate some of the issues of square maintenance attack that is regular in proof of work mining pools which is used to accept the striker's system towards expecting authority over the peer individuals' prizes and some specific parts are Blockchain, conveyed processing, square mining, data provenance, affirmation of-work, square maintenance, flowed record, pool mining, blockchain security, and short coming[5]. The Most of the system use ABE plans, there is only a solitary pro or ace. This structure and all the keys are issued by star expert, which had a problem called ciphertext estimate & incorporate expenses in the security part and unscrambling practices which is expressly in an proportion of attributes. And in this ABE invent most professionals does not need assistant for opening the information in midst of the structure instatement to deal with. In this structure most of them think long condition inserted into data owner, customer & experts TTP using verifiable security approach, it will give you the most dazzling security than each and every stream theory [6]. Distributed storage encourages the two people and ventures who effectively share the data in the Web. In any case, this in like route passes on troublesome so we can few systems only. Then the figure content methodology quality-based encryption is an promise system that empowers the information proprietors themselves to put fine-grained and cryptographically-kept up find the opportunity to command over redistributed data. The monetarily canny trademark- based information get the chance to control for passed on amassing structures [7]. The Multiple Computer System are in the form of handling sources. And it confides in distant organizations with a customer's data and program code, it empowers a client to do a huge measure of capacity, substantial measure of calculations. Because of which information security in the cloud turns into a major issue. Information gets to control gives the security of information in the cloud. The huge measure of information re-appropriated in servers, the data get the chance to control transforms into a checking issue in conveyed stockpiling structures. We have many control system security arrangements like Attribute-based, Role-based, Hierarchical personality the board, Identity-based verification, Trust-based model and so on. Distributed computing is one late advancement. so it turns out to be extremely important to verify the information just as a security of clients. Access Control strategies give a viable method to guarantee that the approved client's entrance the information and the framework [8]. In the late years have seen the pattern of progressively depending on appropriated frameworks. This expanded the number of detailed occurrences of security ruptures trading off clients' protection, where outsiders greatly gather, process and deal with clients' close to home information. One of this security and insurance challenges, we unite dynamic character based crypto frameworks which is rising blockchain systems and propose a block chain-based information utilization reviewing design guaranteeing accessibility and responsibility in a security safeguarding style. Our methodology depends on the utilization of auditable contracts conveyed in blockchain foundations. Along these lines, it is clear and controlling the data access, sharing and getting ready, so unapproved customers or doubtful servers can't process data without customer's approval. Also, in light of cryptographic components, our answer jelly security of information



proprietors and guarantees mystery for imparted information to various specialist organizations. It likewise furnishes evaluating experts with sealed confirmations for information utilization consistency [9]. Access to information has sufficiently increased root because of the coming of innovation. The Internet of Things (IoT) is accepted to be a monstrous hit in certain years to come. Be that as it may, there are bunches of vindictive endeavors by clients when proprietors' information fall into the wrong hands. Accessing information isn't an issue now, however, how the information is utilized in such a path as saving the protection of proprietors is an inquiry yet unanswered. By this we present a blockchain based access control and a calculation domain for information handling. The Validation to the blockchain organize is accomplished through the Elliptic Curve Digital Signature Authentication (ECDSA) convention, which is powerful against general assaults. Information proprietors are advantaged to state to the blockchain arrange which data of theirs is delicate and which ones are definitely not. Handling of touchy information is made in the calculation condition while keen contracts are bound to heartless information [10]. So, thus we conclude the survey which we have undergone for our project and out of that we can come up with some flaws in the existing system and have proposed a system which as follows.

### **III. Existing**

There are distinctive sorts of Access-Based control frameworks which are utilized routinely, for example, DAC, MAC, RBAC. These frameworks examine individuals entering and leaving the premises while building up controls against the individuals who can't pick up get to. What is more, you can introduce these frameworks overall rooms, quarters and regions of your private and business premises. To such an extent that restaurants, shopping centers, and other open spots approach control frameworks introduced for topnotch security and included protection. Though there are some successful capacities in these frameworks, there are a few areas which need some improvements. The fundamental burden of these frameworks is what is frequently called the 'role explosion': because of the expanding number of various (genuine world) Role (now and again contrasts are without a doubt, extremely minor) you need an expanding number of (RBAC) roles to appropriately typify the authorizations (a consent in RBAC is an activity/task on an item/substance). Dealing with every one of those jobs can turn into a complex issue.

### **IV. Proposed**

In this proposed framework, we propose a progressively forthright and direct method for getting information with the utilization of attributes. ABAC (Attribute Based Access Control) controls to get too dependent on a mix of characteristics, i.e., client qualities, asset properties, traits related with the framework or application to be gotten to and ecological attributes. In expansion to basic get to management, ABAC empowers organizations to lessen chances due to unapproved access. Using a blockchain based decentralized record, our framework gives an unchanging log of all significant security occasions, for example, key age, get to approach the task, change or alteration, get to ask.

### **V. Comparison of Existing and Proposed System**

In the existing system, any change in the policies assigned by the clients or change in the property of the data can lead to a Single point failure, whereas, we propose a system which avoids single point failure using Dynamic Access Policy. The current control systems do not have the capacity to store large amounts of data in a peer to peer transactions, but here, ABAC is maintained on blockchain transaction which is able to store, access and modify a huge number of data using the Cloud storage. Subsequently, information will be put away in distributed storage, wherein the data distinguishing the record might be accessible in the blockchain. As referenced previously, the proposed framework can allow benefits to clients while the current models need to change certain frameworks so as to alter benefits.

## VI. System Architecture

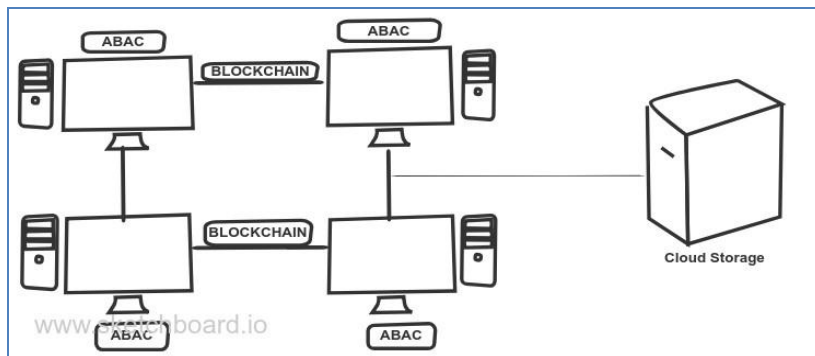

Fig.1

The Architecture explains the fact that here the systems are linked through Blockchain in such a way that whenever a piece of information is shared or accessed by a system, every server that is connected will be notified and alerted. Since nowadays the data being passed around need large amounts of storage space, we use cloud storage to load that piece of information. We manage this process of storing, accessing and modifying data by having Attributes as the main criteria. So every module being attached keeps in mind about the characteristics of both the server and the data.

## VII. Modules

- A. Blockchain Application
- B. Attribute Creation
- C. Cloud Management & Key Generation
- D. Report Generation

### Description

#### A. Blockchain Application:

The Blockchain will collect the primitive data and stores it in the application

Input:

Primitive Data

- Unique-ID
- Owner Name           Kumar
- Date Created           01/01/2019 12:19
- Is Active                True
- Multimedia File Name and many more

Multimedia Data: It can be an Image File or Audio File or Video File

Output: Primitive Data will be stored in the Block chain application.

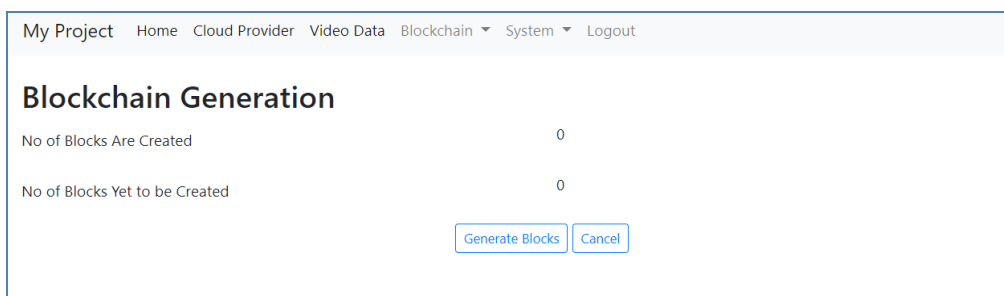

Fig.2

**B. Attribute Creation**

Input: multimedia information, electronic documents

Output: Four Attributes will be created they are

- Subject is the substance (for the most part a client) that demands get to.
- Resource is the substance to be gotten to (for example document, database record, Store Information, ...).
- Action is the task to be completed on the asset (for example peruse, compose, erase, ...).
- Environment is any data in regards to the setting of the entrance that may be utilized in settling on the entrance choice (for example time, arrange, ...). This asset can be gotten to just amid a specific time allotted or from their individual servers.
- The Below Screenshot describes the Time Attribute in the project.

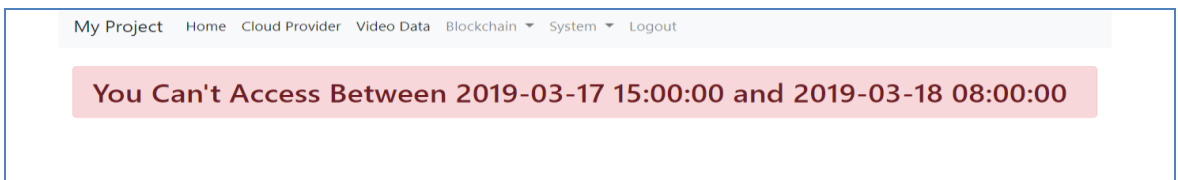

Fig.3

**C. Cloud Management & Key Generation:**

In this Cloud Management process the data and files gets stored in the cloud-based system and tells the storage used and remaining present. Then the key generation process will happen inside the cloud server automatically by giving server key and client key.

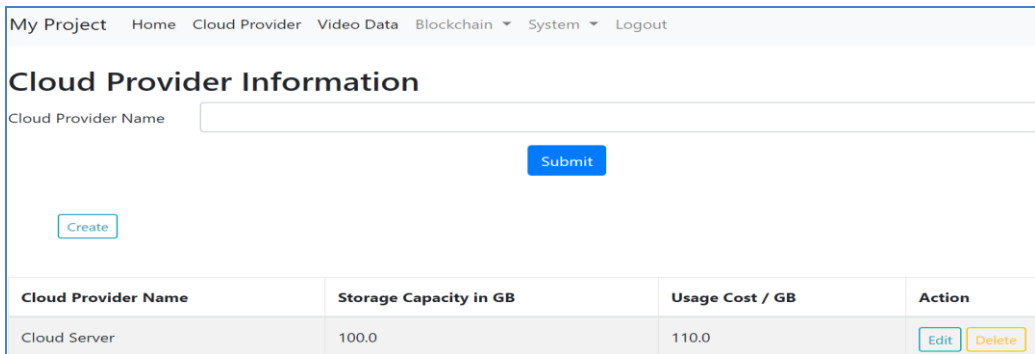

Fig.4

The Below Screenshot shows the file or data after uploading to the cloud server that will check and give the statement as downloaded to server.

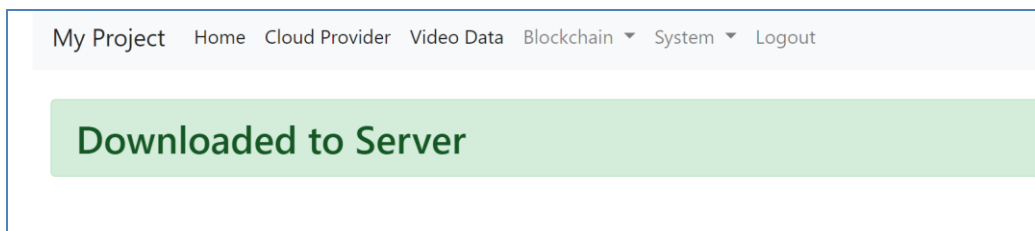

Fig.5

#### D. Report Generation:

After the execution is done the blockchain report will formed as blocks and the data will be saved and hash value of block will be saved in the database.

##### i. Block Chain Report:

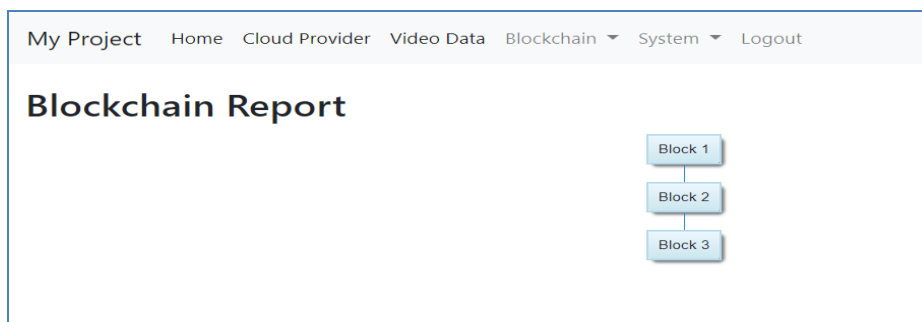
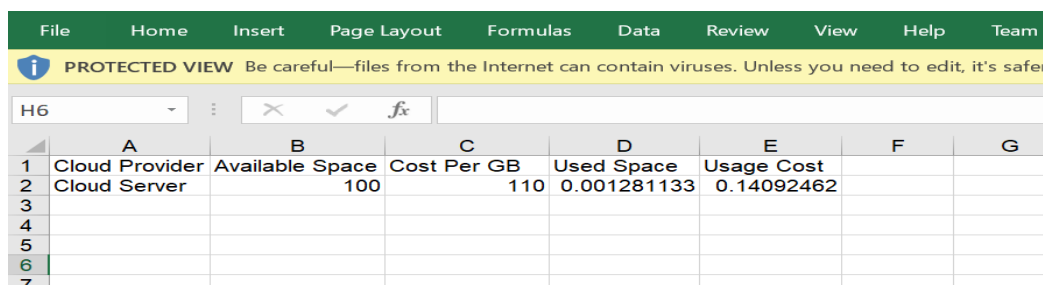

Fig. 6

##### ii. Excel Report:

Then, After the block chain formed the activity of cloud will be displayed in Excel.



	A	B	C	D	E	F	G
1	Cloud Provider	Available Space	Cost Per GB	Used Space	Usage Cost		
2	Cloud Server	100	110	0.001281133	0.14092462		
3							
4							
5							
6							
7							

Fig. 7

#### VIII. Conclusion

The primary concept of this project is the utilization of a digital structure which can help increase the efficiency of accessing a data while also making it a trustworthy model. Our proposed plan gives a verified access control, led by means of the blockchain foundation, and guarantees a satisfactory administration process with respect to efficient whitelists definition. And this is done by adding control processes into the structure using attributes. And each capacity will redo an entrance strategy in scrambled information not allowing to copy by an expansive in members; and get to strategy change does not require any extra activity from different individuals from the framework, which keeps away from the requirement for customary changes to client keys; the transparency of data in all exchanges, counting the giving and modifying access, actualities obtain entrance to document and the powerlessness to alter this information is ensured using the blockchain and trustable contracts.

#### References

1. Hoang Giang Do, Wee Keong Ng, Blockchain-based System for Secure Data Storage with Private Keyword Search, 2017 IEEE Publication.
2. Ilya Sukhodolskiy, Sergey Zapechnikov, Department of Cryptology and Cybersecurity Moscow, Russia, A Blockchain-Based Access Control System for Cloud Storage, 2018 IEEE Publication.
3. Shang-Ping Wang, Yinglong Zhang, School of Science, Xi'an University of Technology, Xi'an, Shaanxi, China, A Blockchain-Based Framework for Data Sharing with Fine-grained Access Control in Decentralized Storage Systems, 2018 IEEE Access.

4. Sujit Biswas, Kashif Sharif, Fan Li, Boubakr Nour, and Yu Wang, Fellow, A Scalable Blockchain Framework for Secure Transactions in IoT, 2018 Iot Base IEEE Published.
5. Deepak K. Tosh, Sachin Shetty, Xueping Liang, Charles A. Kamhoua, Kevin A. Kwiat, Laurent Njilla, Security Implications of Blockchain Cloud with Analysis of Block Withholding Attack, 2017 17th IEEE Published /ACM International Symposium.
6. Gangeshkumar C Rahangdale, Prof. Archana Raut, Dept. Computer Science and Engineering, An Approach for Advanced Multi- Authority Access Control System for Public Cloud Storage, 2017 in IEEE Publication.
7. Jianghong Wei, Wenfen Liu, and Xuexian Hu, Secure and Efficient Attribute-Based Access Control for Multiauthority Cloud Storage, 2018 in IEEE Publication.
8. R Charanya, M Aramudhan, Survey on Access Control Issues in Cloud Computing, 2016 in IEEE Publication.
9. Nesrine Kaaniche and Maryline Laurent, A Blockchain-based Data Usage Auditing Architecture with Enhanced Privacy and Availability, 2017 in IEEE Publication.
10. Ali Dorri, Salil S. Kanhere, School of Computer Science and Engineering, University of New South Wales Sydney, Australia, Raja Jurdak, CSIRO DATA61, Brisbane Australia, Towards an Optimized BlockChain for IoT, 2017 in ACM Publication.

---

# Secure And Open Cloud with De-Duplication Using HMAC Algorithm

Mrs. K Meenakshi, D Kiran , D Pramod Reddy and U Gokula Kannan

Department of Computer Science and Engineering,  
SRM Institute of Science and Technology,  
Chennai, India

---

**ABSTRACT:** *The disposal of copy or repetitive information, especially in PC information is named Deduplication. Information deduplication is a technique to direct the touchy development of data inside the distributed storage, the majority of the capacity suppliers used to discover sheltered and simple ways for ensuring the information in the delicate strategy. Cross-client data deduplication has been comprehensively used to clear out monotonous amassing overhead in appropriated stockpiling system. The term indicated by deduplication. We present a strategy that can dispose of excess encoded information possessed by various clients. This paper is a detail portrayal of secure cloud reviewer which is utilized for the keeping up trustworthiness of imparted information to effective information deduplication on cloud. This instrument utilizes idea of Sec Cloud framework where client can produce information labels before putting away information on cloud which causes amid performing review to check uprightness of information.*

**Keywords:** *Cloud computing, Integrity, Triple Data Encryption Standard (3DES), Data deduplication(HMAC).*

---

## 1. Introduction

Cloud computing empowers new plans of action and practical asset utilization. Rather than keeping up their own server farm, organizations can focus on their centre business and buy assets when it will require. The current cloud expert organizations endeavour both exceedingly attainable capacity and greatly parallel figuring assets at fairly low expenses. One basic test of distributed storage administrations is the administration of the regularly expanding volume of information. Information deduplication is a specific information pressure system for dispensing with copy duplicates of rehashing information away. Deduplication can occur at either the record level or the square dimension for document level deduplication, it kills copy duplicates of a similar record. Customary encryption, while assuring information privacy is contrary with information deduplication. The term encryption has been planned to authorize information privacy while ensuring deduplication achievable. It encodes/reveals an information duplicate with a Convergent key, which is attained by figuring the cryptographic hash estimation of the substance of the information duplicate. After key age and information encryption, clients obtain the keys and dispatch the figure content to the cloud. As the encryption task is necessary and is gotten from the information content, identical information duplicates will yield the equivalent therefore a similar figure content.

### 1.1 Objective

To enhance the security of deduplication and secure the information classification told the best way to ensure the information privacy by changing the anticipated message into an erratic message. In their framework, an outsider called key server is acquainted with produce the record tag for duplication check. Tended to the key administration issue in square dimension deduplication by dispersing these keys over various servers in the wake of encoding the documents

## 2. Literature Review

D. X. Song, D. Wagner, and A. Perrig [7], Proposed a customized proposal has exhibited its adequacy in improving the issue of data over-burden on the Internet. In any case, confirmations demonstrate that because of the worries of individual security, clients' hesitance to reveal their own data has turned into a noteworthy boundary for the improvement of customized suggestion. In this paper, we propose to create a gathering of phony inclination profiles, in order to conceal the client delicate subjects, and in this manner ensure client individual security in customized suggestion. The presentation level of delicate subjects, which estimates the viability of phony inclination profiles to conceal the touchy subjects. At last, in light of a subject vault of item characterization, we present a usage calculation to well meet the security assurance display. Both hypothetical examination and trial assessment show the adequacy of our proposed methodology.

Murat Kantarcioglu and Chris Clifton [3], explains the Capacity as an administration has turned into a critical worldview in distributed computing for its extraordinary adaptability and financial investment funds. Be that as it may, the advancement is hampered by information protection concerns: information proprietors never again physically have the capacity of their information. In this work, we consider the issue of security protecting set-esteemed information distributing. Existing information protection saving systems, (for example, encryption, concealment, speculation) are not pertinent in numerous genuine scenes, since they would bring about extensive overhead for information question or high data misfortune. We demonstrate the protection certification of our component. On information questioning stage, we receive intelligent differential protection procedure to oppose security ruptures from measurable inquiries. We at long last assess its execution utilizing genuine informational collections on our cloud proving ground. Our broad investigations exhibit the legitimacy and common sense of the proposed plan

Javid Taheri, Surya Nepal, and Albert Y. Zomaya, [5] is health care applications. In this article, we handle the issue of planning work process booking calculations to fulfil clients' time constraints, while not bargaining information and assignment security prerequisites. Results show that under our planning arrangements, MPHC-P2 andMPHC-P3 are promising in time-basic situations by lessening the complete expense by 10-20% contrasted with choices.

Sarada Prasad Gochhayat, Mauro Conti, [2], presents Crossover mists have picked up fame as of late in an assortment of associations because of their capacity to give extra limit in an open cloud, to increase private cloud limit, when it is required. One key issue is the peril of uncovering private information and employments in an outsider open cloud framework, for instance in human services applications. In this article, we handle the issue of structuring work process booking calculations to full fill clients' time constraints, while not trading off information and assignment security necessities. Results exhibit that under our booking strategies, MPHC-P2 andMPHC-P3 are promising in time-basic situations by diminishing the absolute expense by 10-20% contrasted with choices. In general, results demonstrate that our methodology is effective in diminishing the expense of executing work processes while fulfilling both their protection and due date requirements.

### 3. Existing System

With the quick developing of storage administrations, for example, distributed storage encryption turns into an essential procedure for securing the secrecy of information. Despite the fact that information encryption gives an imperative certification to the security and protection of customers' information, it constrains the habits of the openness and accessibility of the scrambled information. The impediment of plans with encoded information is that, when some extraordinary handling applications over the information are required, for example, cross-customer information deduplication question arranging over scrambled information the plans generally winds up wasteful because of the successive date encryption and decoding tasks. Along these lines, it is critical to plan effective plans to help secure and proficient calculation re-appropriating and capacity redistributing.

#### 3.1 Proposed System

It has been planned to implement information secrecy while yielding deduplication achievable. It clutters/unclutters the information After key age and information encryption, clients obtain the keys and dispatch the Cipher content to the cloud. Thus end of copy or repetitive information, especially in PC information is named deduplication. Information deduplication is a technique to manage the dangerous development of data inside the distributed storage. A large portion of the capacity suppliers are discovering increasingly secure and effective strategies for their delicate technique. It is utilized for the keeping up honesty of imparted information to proficient information deduplication on cloud to ensure the secrecy of delicate information while supporting deduplication. The merged encryption strategy has been proposed to encode the information before redistributing. It scrambles/decodes an information duplicate with a concurrent key In this Problem definition, the plan of approved information deduplication was planned to guarantee the information And secure by including differential perks of clients in the copy check. It gives approval to the private firms and secures the classification of the essential.

#### 4. System Architecture

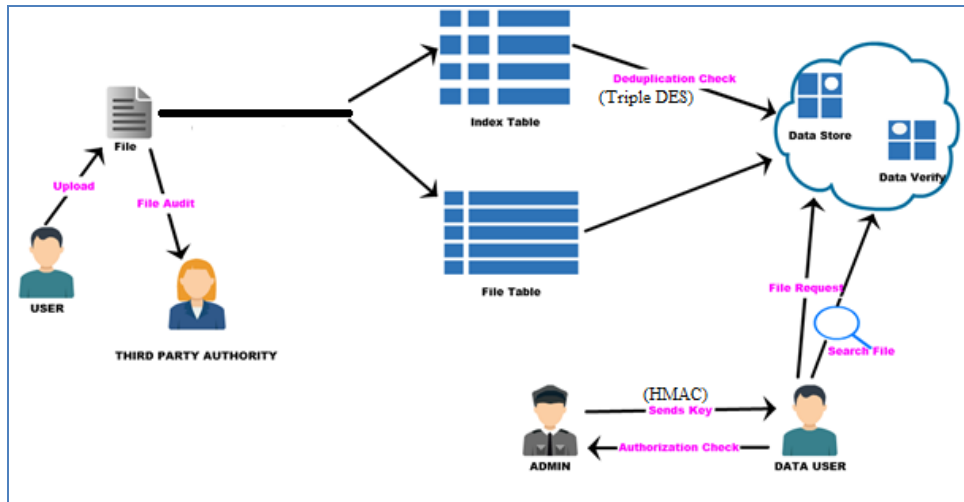

Fig 1: System architecture

Information proprietor can transfer data's, that information are part into part information at that point send to believed information checker in the event that confuse, at that point that information client determined calculation, at long last scramble at that point store in Database. In this proprietor informational collection we make information proprietor dataset, this dataset just guide proprietor adequately In this modules, the outsider evaluator checks for the document uprightness. On the off chance that the record contains indistinguishable word from was in the document recently spared in the cloud at that point record won't store rather it demonstrates error. enormous information rather than one a kind on the grounds that productively discover duplication and memory the board, if information proprietor share our information to customer that information not imitate rather map customer name. We are executing "Triple Dynamic Encryption key Generation". It implies every single datum just information proprietor consent, so we can maintain a strategic distance from obscure access. Social clients are bunch individuals they can just view and share the information.

#### 5. Modules

- Data Owners
- Owner Dataset
- Third Party Verifier
- Mutual Dataset
- Security

#### Modules Description:

##### 5.1 Data Owners

Information proprietor can transfer data's, that information are part into part information at that point send to believed information checker, occupation of the information checker is to create signature key from MD5 and contrast and past keys, on the off chance that crisscross, at that point that information send to Key generator Server, Job of the key generator are produce encryption key as client determined calculation, at long last scramble at that point store in Database.



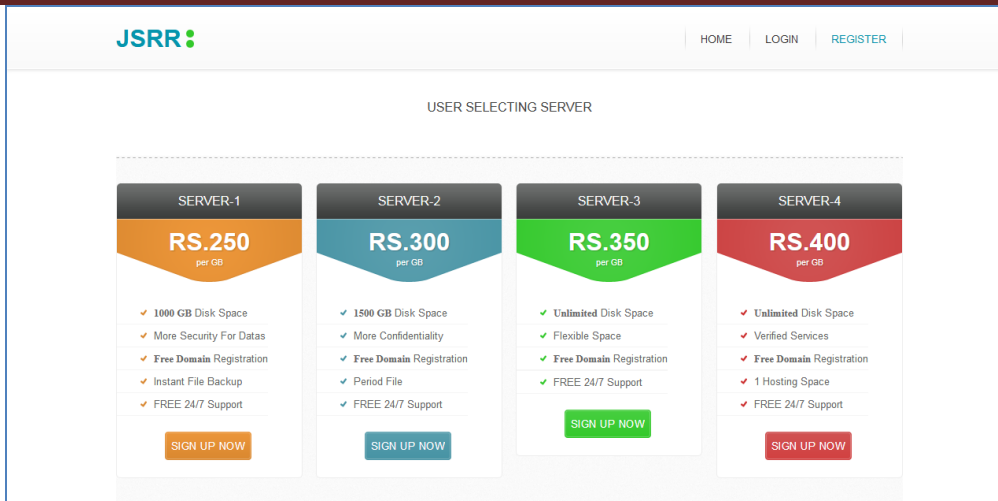

Figure (2) Registration

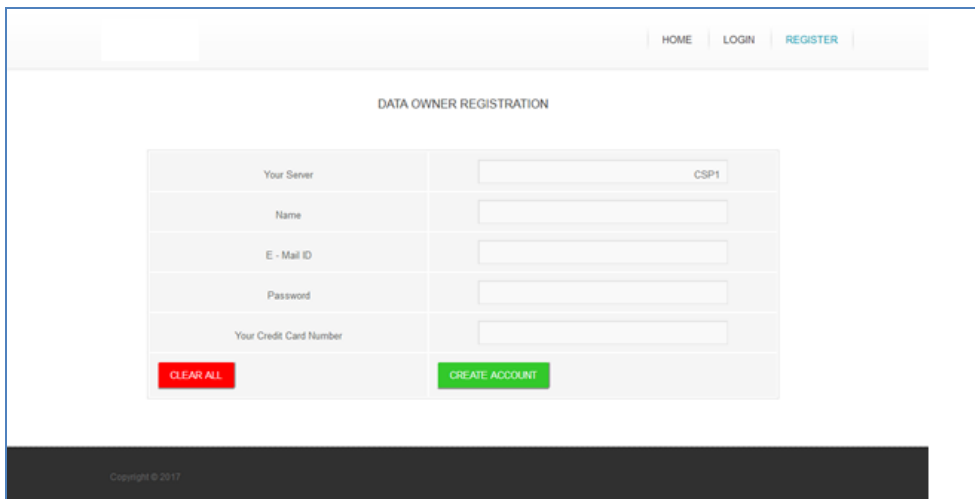

Figure (3) Data owner registration

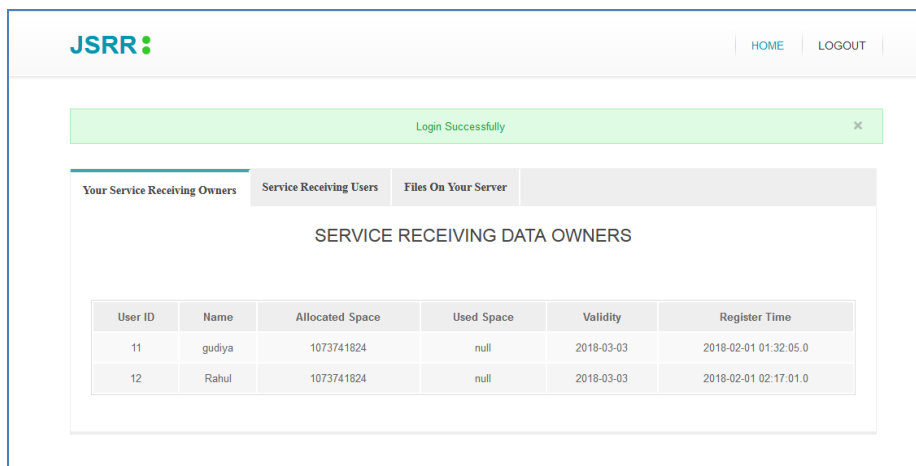
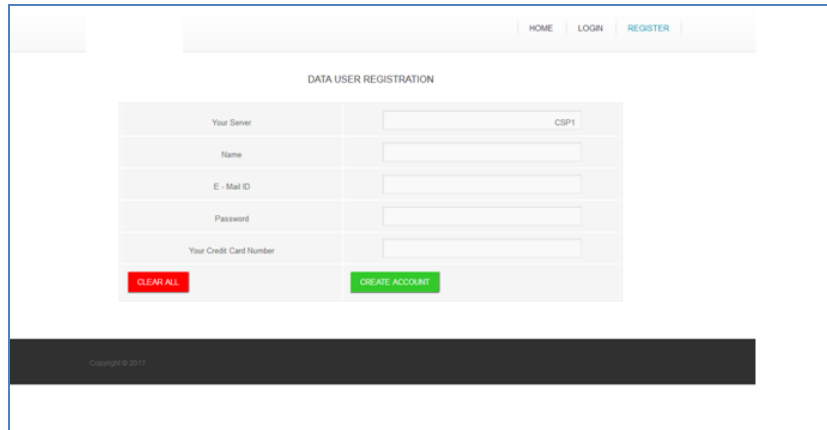

Figure (4) Data owners login page

## 5.2 User Dataset

In this Module We make information proprietor dataset, this dataset just guide proprietor with our transfer data's, we keep up regular database for successfully discover duplications. The documents will transfer just once. In the event that another information proprietor going to transfer a similar document in database implies they will get the warning (the information is now transferred in database).So information proprietor can spare expense and time.



The screenshot shows a web interface for 'DATA USER REGISTRATION'. At the top right, there are links for 'HOME', 'LOGIN', and 'REGISTER'. The main form contains several input fields: 'Your Sener' (with 'CSP1' as a placeholder), 'Name', 'E - Mail ID', 'Password', and 'Your Credit Card Number'. Below these fields are two buttons: a red 'CLEAR ALL' button and a green 'CREATE ACCOUNT' button. At the bottom left of the page, there is a small copyright notice: 'Copyright © 2017'.

Figure (5) Data user registration

## 5.3 Third Party Verifier

In this modules, the outsider inspector checks for the record honesty. On the off chance that the document contains indistinguishable word from was in the record recently spared in the cloud at that point document won't store rather it indicates blunder . The TPA will channel the record. On the off chance that the record makes them refresh with uniqueness, at that point TPD will acknowledge the document and scramble the record and put away to the cloud.

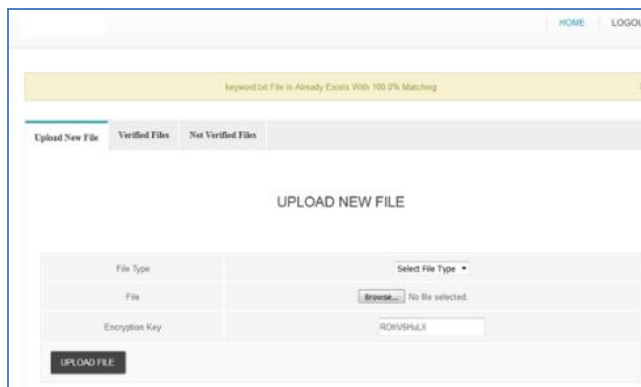

The screenshot shows the 'UPLOAD NEW FILE' interface. At the top right, there are links for 'HOME' and 'LOGOUT'. A yellow notification banner at the top states: 'keyword.txt File is Already Exists With 100 % Matching'. Below this, there are three tabs: 'Upload New File', 'Verified Files', and 'Not Verified Files'. The main heading is 'UPLOAD NEW FILE'. The form includes a 'File Type' field, a 'Select File Type' dropdown menu, a 'File' field with a 'Browse...' button and the text 'No file selected', and an 'Encrypton Key' field with the value 'RANDOMSHAKE'. At the bottom left, there is a black 'UPLOAD FILE' button.

Figure (6 )Deduplication check

## 5.4 Mutual Dataset

If information proprietor share our information to customer that information not recreate rather map customer name. Information deduplication empowers information stockpiling frameworks to discover and evacuate duplication inside information without trading off its accessibility.

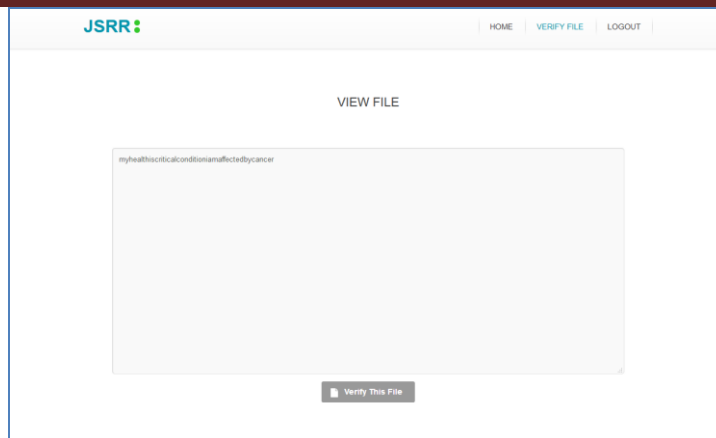

Figure (7) View file

### 5.5 Security

We are executing "Dynamic Encryption key Generation". It implies every single shared datum just view with information proprietor consent, so we can maintain a strategic distance from obscure access. Social clients are aggregate individuals they can just view and share the information. On the off chance that need demonstrate the information mean they have to get consent to information proprietor then information proprietor will send Encryption key after they can see the information. On the off chance that information proprietor does not give the KEY mean client can't see the document. Information encryption gives a vital assurance to the security and protection of customers' information, it restrains the habits of the openness and accessibility of the scrambled information

### 6. Conclusion and Successive Works

Cloud information security is an essential perspective for the customer while utilizing cloud administrations. Outsider Auditor can

be utilized to guarantee the security and trustworthiness of information. Outsider reviewer can be a believed outsider to determine the contentions between the cloud specialist organization and the customer. The static deduplication choice tree is built dependent on the irregular components from the customer, which does not enable the tree to refresh. Be that as it may, the dynamic deduplication choice tree is built dependent on the planned self-age tree, which enables the server to direct tree refresh and some other enhancement. The security, hypothetical and down to earth execution investigation demonstrate that our plan is secure and it accomplishes a few requests of size higher execution than the best in class conspires in useful information deduplication.

### 7. References

1. Stanley RM, Oliveira, Osmar R. Zalane. "Protecting Sensitive Knowledge By Data Sanitization", IEEE Transactions on knowledge and data mining pp.7695-1978-4/03
2. Sarada Prasad Gochhayat, Mauro Conti, Privacy Aware Data Deduplication for SideChannel in Cloud Storage", IEEE Transactions
3. Murat Kantarcioglu and Chris Clifton. "Privacy-Preserving Distributed Mining of Association Rules on Horizontally Partitioned", Data IEEE transactions on knowledge and data engineering. 2004; 16:9.
4. Xiao-Bai Li and Sumit Sarkar. "A Tree-Based Data Perturbation Approach for Privacy-Preserving Data Mining", IEEE transactions on knowledge and data engineering, vol. 18, no. 9, september 2006
5. Javid Taheri, Surya Nepal, and Albert Y. Zomaya, Privacy-Aware Scheduling SaaS in High Performance Computing Environments
6. D. Boneh, E. Kushilevitz, R. Ostrovsky, and W. E. Skeith III, "Public key encryption that allows pir queries," in Proc. Adv. Cryptol., 2007, pp. 50-67.
7. D. X. Song, D. Wagner, and A. Perrig, "Practical techniques for searches on encrypted data," in Proc. IEEE Symp. Secur. Privacy, 2000, pp. 44-55.
8. E.-J. Goh, "Secure indexes," IACR Cryptol. ePrint Archive, vol. 2003, p. 216, 2003.

9. Y.-C. Chang and M. Mitzenmacher, "Privacy preserving keywordsearches on remote encrypted data," in Proc. 3rd Int. Conf. Appl. Cryptography Netw. Secur, 2005, pp. 442–455.
10. R. Curtmola, J. Garay, S. Kamara, and R. Ostrovsky, "Searchable symmetric encryption: Improved definitions and efficient constructions," in Proc. 13th ACM Conf. Comput. Commun. Secur, 2006, pp. 79–88.
11. Dr. Nandita Sengupta, "Designing of Hybrid RSA Encryption Algorithm for Cloud Security", International Journal of Innovative Research in Computer and Communication Engineering, Volume 3, Issue 5, May 2015.
12. Hanumantha Rao, Galli and Dr. P. Padmanabhan, "Data Security in Cloud using Hybrid Encryption and Decryption" International Journal of Advanced Research in Computer Science and Software Engineering, Volume 3, Issue 10, October 2013.
13. S. Munjal1 and S. Garg, "Enhancing Data Security and Storage in Cloud Computing Environment" IJCSIT, Volume 6, 2015.

---

# Enhanced Cloud Storage Security using Data Slicing and Hybrid Cryptography

Sidharth Sridhar, Arun Muralidharan, Mohammed Ashik and Vidhyasagar BS

Department of Computer Science and Engineering,  
SRM Institute of Science and Technology,  
Chennai, India

---

**ABSTRACT:** *The rate of storing information on cloud is tremendously high and keeps growing daily, this massive growth also accompanies with various malicious activities in cloud. Cloud security is getting more important now than ever, but the security for data stored in cloud is still not guaranteed by the cloud providers. This paper proposes a middleware that securely authenticates user, encrypts user files, uploads that to the storage cloud system and vice versa. The middleware slices the file being uploaded into multiple parts and names it with random string, encrypts each segmented part with the proposed hybrid cryptographic algorithm then uploads them into cloud storage system. This mechanism of storing and retrieving guarantees data security in cloud environment. We use APIs and libraries provided by cloud providers for implementing this system.*

**Keywords:** *Cloud Computing, Hybrid Cryptography, Data Slicing, Cloud Security*

---

## 1. Introduction

Cloud computing is a powerful internet-based technology which provides various computational resources as on-demand service to the users. The main success of cloud computing lies in the on-demand network access to a shared tank of computing resources, mainly servers and the storage applications. The ability to upscale and downscale resources according to the users need is advantageous. This is achieved through proper on-demand administration, resource pooling and virtualization. Cloud computing has brought many improvements in the world corporates and startups by allowing organizations to use resources effectively and reduce overall IT cost [6]. With cloud computing, users can deploy services in minutes with minimal or without the support of cloud provider.

Cloud computing serves on three models, namely 1) Infrastructure as a Service (IaaS) 2) Platform as a Service (PaaS) and 3) Software as a Service (SaaS) [6].

### 1) Infrastructure as a Service (IaaS)

IaaS is a service model in cloud computing that delivers computer infrastructure like hardware, storage, servers, data centers, network components and other fundamental components as metered service to the user. It is also known as Hardware as a Service colloquially. The user can have total control over operating systems, storage, deployed applications, and limited control of selecting the network components, GPU engine and component manufacturer of the underlying cloud physical infrastructure. Infrastructure as a Service technically allows users to do all task that takes a call to someone in the cloud provider's data center. Example: AWS EC2, IBM SoftLayer, Rackspace etc. [17].

### 2) Software as a Service (SaaS)

SaaS is a service model in which software is delivered as a service to the users over the Internet on pay as you go basis from the cloud provider. The cloud provider's data center contains all the infrastructure, middleware, apps and app data. The service provider manages legal hardware and software licenses and agreements that ensures the availability and security of the applications and user data. SaaS allows organization to run applications at minimal upfront and cost. Example: Abode Creative Cloud, MS Office 365, Salesforce.com etc. [17].

### 3) Platform as a Service (PaaS)

PaaS is a service model in cloud computing that describes delivery of computing platform as an integrated solution, solution stack or service over the internet. It provides a complete development environment as metered service to the users. It allows rapid development, management and control of applications. It is integrated from the basic infrastructure components. It allows user to get virtualized servers and services

needed to run or host the application on the go. Example: AWS Codestar, IBM Bluemix, Microsoft Azure etc. [17].

Cloud storage is a data storage paradigm where data is stored in logical pools digitally. At present the world runs out of storage in their local device. They needed an extra storage that should be available anytime and anywhere. The cloud storage is the only solution to it. Cloud storage provides various storage facilities and service as per the user's needs. Certain mobile and computer manufacturers have started providing free cloud storages to their users to certain limits and charges as per the use exceeding the free limit. Cloud storage makes storing and transfer of large file in an ease. This character of cloud storage systems makes users to store their personal data, old data and critical data for reliability purpose to store in cloud.

Some of the popular storage cloud systems are:

### 1) Google Cloud

Google provides a unified and durable storage to the internet. It allows storage and retrieval of any amount of data [13]. Google Drive is a free cloud storage provider which itself relies on Google Cloud, to provides file storage and synchronization service. It provides easy storage and transfer of user data. All Google applications like Gmail, Photos, Notes, Docs, Sheets, Slides etc use Google Cloud as their backend storage.

### 2) AWS S3

Amazon S3 stands for Simple Storage Service. It is an object storage service that offers large scale storage. It comprises a simple interface that can be used to upload and later download any amount of data, 24X7 anywhere around the world via internet. It has its own security system that provides various authentication mechanisms to secure data that is stored in Amazon S3 against unauthorized access but still it does not guarantee data security on whole. The common use scenarios include Backup Storage, Application hosting, Media hosting and Software delivery [14].

### 3) Rack-Space

Rack-Space offers object storage for files, apps and media online. It delivers service globally at very high speeds via world-wide content delivery network [15]. It can able to store any kind of files without any size limitations. The Rack- space system maintains three copies of each file, that are stored in it, so that the users get quicker file access and more reliable storage service. It is powered by the powerful open source technology, OpenStack [15].

Since Cloud Computing rest on internet, the user data stored in cloud storage systems are always prone to security issues like data leakage, data theft, data modification, unauthenticated access to data and various hacker attacks. These are mostly due to the weak identity management, patch management, unsafe API's and internal and government threats [9]. Hence to get an overwhelmed acceptance to cloud storage, we have proposed a middleware system that authenticates user, encrypts user files, uploads user data to the storage cloud and vice versa.

### 4) QNAP

QNAP provides high-quality network attached storage service to its users via internet. It uses QSync, a cross device file synchronization system to sync data between the QNAP NAS and other devices like desktops, laptops, tablets and mobile phones to provide flexible collaboration [16]. User can store and access any kind of media or document anywhere and anytime. It also provides a mobile application to remotely take control of data stored in QNAP NAS and stay synchronized.

### Literature Review

Sandeep Nehe and Prof. M.B. Vaidhya [4], proposed a unification framework that uses various IaaS layers to merge storages between two or more cloud storage system. The system proposed by the researchers is also a middleware system, that authenticates users and uses cloud storage systems such as DropBox, Box, OneDrive as storage backend [4]. It adds a layer of security above these cloud storage systems by distributing the file by slicing and storing it into different cloud storage systems. The middleware slices the file being uploaded into multiple segments, encrypt them and uploads each segment to each cloud storage backends. The middleware logs all these segmentation, encryption, distribution details and user details in a database. Whenever the user wants to access the file, the middleware recreates the original file by merging the segments and allowing users to view or download [4]. The issue with this system is the consumption of time for fetching the data segment from different cloud storage systems. The coordination level between the

cloud storage systems should be very high in order to rely on this system. If any one of the storage systems is unreachable, it is hard to recreate the original file.

Shirole Bajirao and Dr. Sanjay Thakur [5], explains the use of symmetric encryption technique to resolve the current security challenges in cloud environment. The system proposed by author performs a blowfish symmetric encryption on the data and converts it into cipher followed by uploading it onto the cloud storage. When the data from cloud needs to be accessed, the system retrieves, decrypts using the respective keys and stores the data locally into the user's system. This internally preserves the data and builds a cooperation bridge between the user and cloud service provider [5]. Authentication is achieved through One Time Passwords in this proposed model. This way of securing data may seem simple but has its own flaws in it. The blowfish encryption algorithm used in this system is prone to second order differential attack and are highly not recommended to use in any cloud computing storages which contains critical data.

Parsi Kalpana and Sudha Singaraju [3], states that cloud computing is rapidly growing and has a lot of space for research in it. As cloud computing is a model based out of open environment, security being the prime challenge for the deployment of cloud environments. The author proposes RSA algorithm to secure the cloud environment in this paper. RSA is an asymmetric cryptographic algorithm and an acronym of Ron Rivest, Adi Shamir and Len Adleman [2]. The process involves encryption of the data that is to be uploaded to cloud storage system. On decryption, the data is downloaded from the cloud, the cloud provider authenticates the user, then allows the users to download and the data is decrypted. Here RSA algorithm is used to prevent unauthenticated access to the attacker and so the system is secure [2]. Public key is distributed to all while the private key is only available with the genuinely accessing user. The encryption and decryption process are carried out in the user side. Once the data gets encrypted with the user's public key, the user's exact private key must be specified to decrypt the encrypted data. RSA algorithm involves Key Generation, Encryption and Decryption process. The Key generation takes place between the cloud service provider and the accessing user then followed by the encryption and decryption process. This system prevents unauthenticated access and illegal access to data that are stored in cloud [2]. However, the researchers failed to emphasise the importance of the time consumption for the entire process of encryption and decryption using asymmetric algorithm (RSA). This is time consuming and will limit the usage of this technique on large files.

Vishwanath S Mahalle and Aniket K Shahade [1], presents a Hybrid Cryptographic algorithm to preserve data security in Cloud Systems. The system proposed in this paper is implemented in eye-OS and the hybrid algorithm is made possible by coupling the AES-128 symmetric encryption algorithm and RSA-1024 asymmetric algorithm [1]. The file that need to be stored in the public cloud is stored into a temporary storage and encrypted using AES-128, then uploaded into the cloud storage system. The key of the AES Encryption is again encrypted using the asymmetric RSA encryption using the public key and can only be decrypted using the private key which is only known to the data owner. It is also observed that this can also be used on large files because of its encryption speed and less consumption of computational resource.

R. Kiruthika, S. Keerthana and R Jeena [9], detailly explains the current security issues that are faced in the cloud computing environment. The author comes up with the proper stats and key issues regarding data security in cloud. Their solution to the issues is through Advanced Encryption Standard (AES) encryption. The author compares the algorithm with various other encryption algorithms in terms of encryptions per minute, hardness of the encryption and time consumption to justify the use of AES for securing the cloud storage. The idea is simply encrypting the data that is stored in cloud storage with AES encryption. The key for the encryption is maintained by a separate physical key management server to add security and this should be installed in the user's premise. The author claims that encryption keys and data stored in cloud storage in secure and under user's control in this method.

### **Proposed System**

The proposed system is a middleware which uses techniques that involves data slicing and coupling of symmetric and asymmetric algorithm (Hybrid) for secured and optimized results. Each cryptographic algorithm follows both the encryption and decryption process. The file that to be uploaded into the cloud storage will be split by the middleware's splitter into multiple parts with random names assigned to each segmented part. On encryption the original data in the file gets encoded into cipher data, which is not understandable to humans. The symmetric encryption includes AES, CAMELLIA and SERPENT, these are applied into each segmented parts of the original file on random selection and are directly uploaded and stored into the cloud storage system. It is not necessary that all the three encryptions must be applied to the segments of the file. The encryption can be applied in any combination of the three. The randomly applied



symmetric algorithm is logged into a file which contains the map of the encryption and associated keys respectively. This file is encrypted with RSA algorithm and stored with the same name as the original file name (i.e.) it requires the appropriate private key which the accessing user only has, to decrypt the file. To retrieve the original data from the encoded cipher, decryption process is carried out. To decrypt, the user's appropriate private key needs to be entered, on successful private key entry the map file gets decrypted and the system parses the respective keys for each segment from the file, merges the segments, recreates the file and makes it available for the user to view or download.

### System Architecture

The proposed system is a three-tier architecture with multiple sub layers in it. The architecture involves Data Owner/User, Middleware System and the Cloud Storage System. The mode of communication takes place with HTTPS.

#### A) User

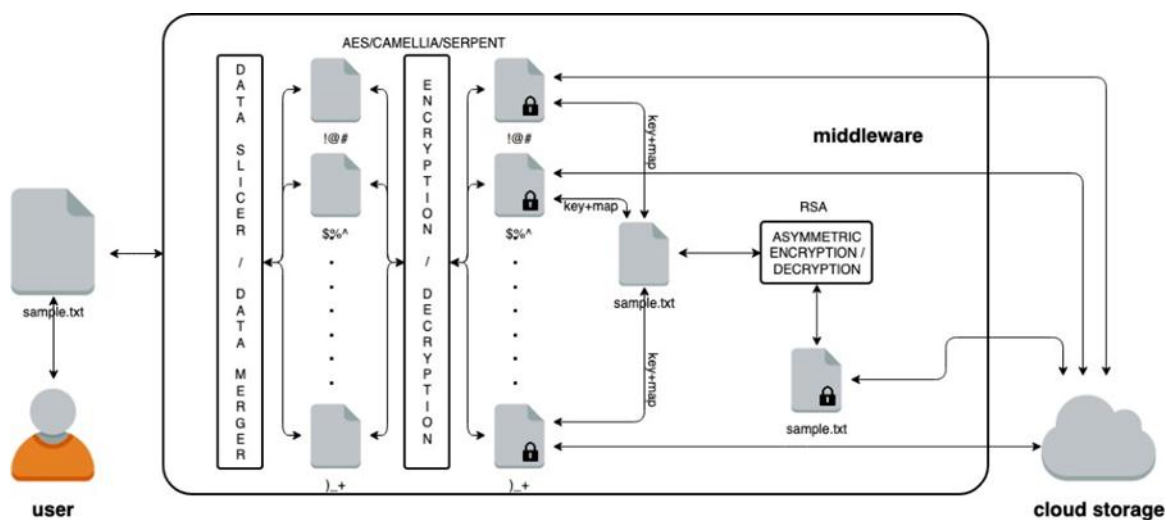

Figure 1: System Architecture

The user is an actor who uploads or downloads the file to or from the storage cloud system respectively. He/she can access the system by entering the credentials in the middleware that opens the connection to the storage cloud and able to perform actions in it.

#### B) Middleware

The middleware is the hub that connects all the components of the architecture. The middleware has three main interfaces in it and are exposed as following components:

##### 1. Upload/Download

This is the initial module to get executed on any operation. On uploading the file is sent to the Data Slicing module and are sliced into multiple parts with random names assigned and then sent to the encryption module. On downloading the parts of the files are fetched as per the map file and are sent to the Data Merger module which merges and makes the file available to the user to view or download.

##### 2. Data Slicing/Data Merging

On uploading the middleware calls the Data Slicing module which splits the file into multiple parts. The data slicing algorithm divides the total size of the file by n. This involves byte coding. These sliced parts are created by simple I/O system calls.

On downloading, after successful decryption these parts are fetched as per the data parsed from the map file. The Data Merger modules simply appends the start byte to the end byte of the pervious part. Thus, the whole file is recreated same as the original file and are made available to view or download.



**3. Encryption/Decryption**

On Encryption each part of the file is encrypted with random selection of AES/CAMELLIA/SERPENT and are directly uploaded into the cloud storage system. The algorithm used to encrypt each part and their respective keys are logged by the middleware system and are stored in a separate file which has the same name as the original file name. This file is encrypted using RSA and stored in the cloud storage.

On Decryption, the middleware system asks for the user’s private key to decrypt the map file, which contains the map and key for the parts of the original file. These are used to decrypt the sliced parts of the file.

**C) Cloud Storage**

Cloud storage is the place where the data technically gets stored in cloud. These are the part of cloud computing data centres located in different locations in a protected environment. Data that is processed, transmitted and kept in cloud are logically stored in some storage pools in cloud, and are called cloud storages.

**Performance Analysis**

The performance of the system is evaluated based on the time taken by the middleware to upload and download the file to and from the cloud storage system respectively.

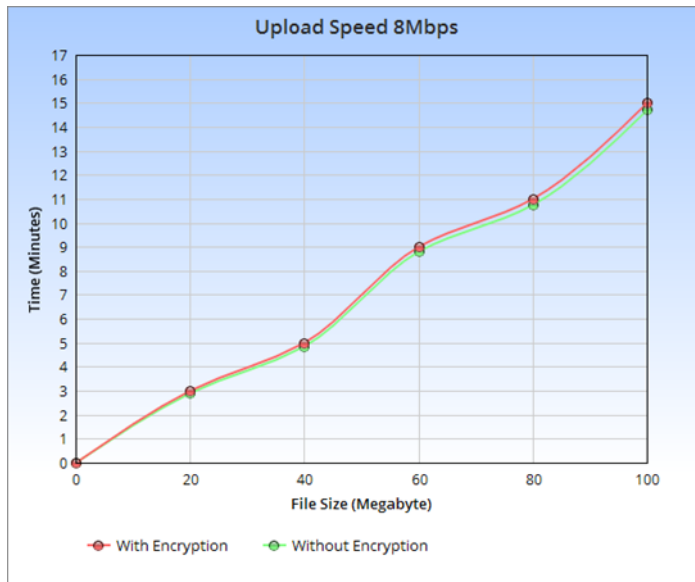

Graph 1: Upload time with variable file sizes

From graph 1, the total execution time taken by the middleware is fairly linear. Minor variations are present only because of fluctuation in upload speed. If the upload speed is stable then the graph would be perfectly linear. Also, the time taken by the encryption algorithm has a minor impact on the overall execution time of the intermediary (system). For example, to encrypt a 100MB file, the encryption algorithms take only 2.5s in total. The total time taken to upload includes splitting files into multiple parts, encrypting multiple parts, uploading multiple parts and master file to cloud. Total time for execution mainly relies on the upload speed of the ISP.

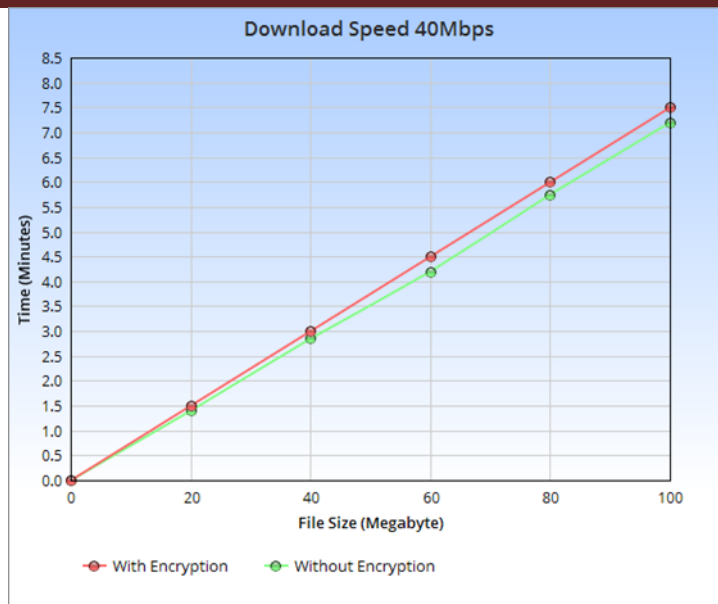

Graph 2: Download time with variable file sizes

Since the download speed is stable, we were able to obtain a linear graph. The time taken for decryption is less than the time taken for encryption because of the preexisting keys and initial vectors (No need to generate random keys and initial vectors again). There is not much variation in time for files uploaded with and without encryption. For downloading the file with decryption, it takes around 7.5s and for downloading the file without any decryption it takes around 7.2s. This time also includes the time to decrypt and merge to recreate the original file. The variation may seem noticeable if the file size is very large, but higher security comes at the expense of higher cost.

### Conclusion and Successive Works

In this paper, we have proposed a new technique in cloud storage security with the use of Data Slicing and Hybrid Cryptography by AES, CAMELLIA, SERPENT and RSA algorithms for providing data security to the files that are stored in cloud storage systems. As the original file is segmented and scattered in the storage pool with random names it is hard for any attacks and attackers to illegally access the data stored in it. As the private key is only known to the accessing user, it is impossible for anyone to illegally access the file in the cloud storage system. The main purpose behind the usage of AES/CAMELLIA/SERPENT and RSA is to provide utmost data security and reduce the overall computation time required for encryption and decryption of data. The key advantage of this system is, it is completely secured, automated and doesn't require any user actions other than entering the private key and completely secure on cloud environment. Future works involves performance improvement, adding support for multiple clouds and extending the system further to decentralized storages.

### References

1. Vishwanath S Mahalle and Aniket K Shahade, "Enhancing the Data Security in Cloud by Implementing Hybrid (RSA & AES) Encryption Algorithm" IEEE Publication, 2014.
2. Divya Prathana Timothy and Ajit Kumar Santra, "A Hybrid Cryptography Algorithm for Cloud Computing Security" IEEE Publication, 2017.
3. Parsi Kalpana and Sudha Singaraju, "Data Security in Cloud Computing using RSA Algorithm" International Journal of Research in Computer and Communication Technology, IJRCCT, Volume 1, Issue 4, September 2012.
4. Sandeep Nehe and Prof. M.B. Vaidhya, "Data Security using Data Slicing over Storage Clouds" International Conference on Information Processing, ICIP, December 2015.
5. Shirole Bajirao and Dr. Sanjay Thakur, "Data Confidentiality in Cloud Computing with Blowfish Algorithm" International Journal of Emerging Trends in Science and Technology, IJETST, Volume 1, Issue 1, March 2014.

6. Jasleen Kaur and Dr. Sushil Garg, "Security in Cloud Computing using Hybrids of Algorithms" International Journal of Engineering Research and General Science Volume 3, Issue 5, September-October 2015.
7. Kumar, K. Vijay, B. Srinivas Reddy and Dr. N. Chandra Sekhar Reddy, "Preserving Data Privacy, Security Models and Cryptographic Algorithms in Cloud Computing" International Journal of Computer Engineering and Applications, 2015.
8. Deyan Chen and Hong Zhao, "Data Security and Privacy Protection Issues in Cloud Computing" IEEE International Conference on Computer Science and Electronics Engineering, 2012.
9. R. Kiruthuka, S. Keerthana and R. Jeena, "Enhancing Cloud Security using AES Algorithm" International Journal of Advanced Research in Computer Science and Software Engineering, Volume 5, Issue 3, March 2015.
10. Dr. Nandita Sengupta, "Designing of Hybrid RSA Encryption Algorithm for Cloud Security", International Journal of Innovative Research in Computer and Communication Engineering, Volume 3, Issue 5, May 2015.
11. Hanumantha Rao, Galli and Dr. P. Padmanabhan, "Data Security in Cloud using Hybrid Encryption and Decryption" International Journal of Advanced Research in Computer Science and Software Engineering, Volume 3, Issue 10, October 2013.
12. S. Munjal1 and S. Garg, "Enhancing Data Security and Storage in Cloud Computing Environment" IJCSIT, Volume 6, 2015.
13. <https://cloud.google.com/storage/docs/>
14. [https://docs.aws.amazon.com/s3/index.html#lang/en\\_us](https://docs.aws.amazon.com/s3/index.html#lang/en_us)
15. <https://www.rackspace.com/cloud/files>
16. <https://www.qnap.com/en-us/>
17. <https://www.ibm.com/cloud/learn/iaas-paas-saas>

---

# Recommender System and Stock to Profit Possibility System Using Swarm Intelligence in E-Commerce

Shubham B Kumbhar

Student,

Computer Science, SRM Institute of Science and Technology,  
Chennai, India

---

**ABSTRACT:** This research is meant to be done in the aspect of user experience and inventory stock filtering in any e-commerce or e-tail business. The recommendations shown to the users are of the highest priority to increase in sales revenue is quite often seen and also the part where service quality has a quite good connection to the recommendations shown to the users is been noted down. The research work has been more focused on collaborative filtering which is an algorithm used by the Amazon to get their e-commerce running for recommendations. Since recommendations are done over the concept of generalization under similar categories and based only on rank the results are seen to be not promising to the business as well as the users. While research the developed algorithm is based on swarm intelligence concept which is able to dig through the event clearing and also geo-location and many such parameters to give more accurate results around the business. This research also takes into consideration the point that user behavior can be of good signal to provide the stock management ineffective way to avoid stock rolling and create better market stability on the transfer of goods. The system is suited to create awareness into business for sales increase and easier to find products approach for users which is quite less currently and well pointed by most of the customers in the reviews for many businesses.

---

## 1. Introduction

The research is well-confined on certain parameters which are found to be quite necessary for users like rating, the pattern of sale and buy event parameters. It is quite not new to know that when customers visit any e-commerce website they are usually into window shopping at later part than actually trying to figure out what they want to buy. This happens because when they enter they are shown something which is not actually relevant to what they want to buy and they end up getting involved in window shopping. This creates an issue on the current system of recommendation which is mostly working on collaborative filtering and is not proven in general but to keep it as nearby considering that Amazon is into using a collaborative filtering method. The whole method discussed in this research is not the modification of any existing algorithm but using swarm intelligence which is a concept and well-proven method to learn patterns in nearly no data capture. The method being used is connected to prove results faster and more of interest to current users to get a higher amount of traction towards getting better conversions. The resulting answers would not be of a certain user only but be able to figure out patterns from earlier users and by some basic questions being answered by any new login, it would be able to provide some great answers towards the new users. This whole system is more of based to sell off recommendations to the need of users and way the users react up to the past they have been into. This research focuses to not only increase the environment in specific for the user to be friendly but also to increase the overall sales value of the e-tail business. It is also able to predict possible stock changes needed to make sure that profit remains high and less amount of rolling of money is involved.

## II. Terminology

### 2.1 Collaborative Filtering

It is a proven method and used by many e-tail businesses for a recommendation system. It is usually to narrow down the interest of the user about their taste and want to buy stats. It is done by scouting through multiple users and then looking for maximum similar patterns and then map the psychology to the same mapping found and then provide the outcome which is further used by the system to judge the possible recommendation. This system requires more and more data to provide better results and is not known to provide perfect results even after heavier formatted data from unique as well as many users. The issues found also encompasses the matter of new users too.

## 2.2 Swarm Intelligence

It is a sort of technology which is being inspired by a swarm of insects mostly. Being part of the artificial intelligence tree the swarm intelligence does have some data parameters but is completely different in behaviour than normal artificial intelligence algorithms or concepts. For a better explanation over here in this research, we will be looking towards the swarm concept over bees and understand further deeply. Bees are normally attached over to a certain beehive and there are different sort of bees which include queen bee which is responsible for the production of other bees and then comes the bee workers who are the one which creates the beehive and also responsible to act as a guard for the beehive. Then comes the last bee drones whose work is to just mate with bee queen to create more bees. Now, moving towards more about the research the part where these bees' attacks or works are quite connected to an observation of surrounding than to directly act on some communication medium like language. They look forward to how one certain block was placed and see which is available next or required to be put to keep the stability and also keep the progress going on. While attacking also bee make sure to see where the last bee attacked and or nearby bees are attacking and then what was the outcome of easiest defence and also attack and then follows the pattern then just co-ordinating some strategies.

## 2.3 Bounce Rate

The amount of users who visit back on the website links further or go for other features than to directly jump to another website or close the website on the first look. It is normally given in percentage and the lesser the bounce rate is meaning more the users are trying to quite from the website leading to better conversions.

## III. Methodology

The user interest is found on the basis of various parameters namely their previous buy history, their geographic location, their interests and any certain filters they use in common. Further, the algorithm is also able to provide the possible knowledge to ask a questionnaire to the new user to get their interest map easily and then put that to good use and get a better recommendation at the first visit. The recommendations are put up greatly of higher importance for newer users for the reason that if the experience at first glance does not seem to be good the bounce rate increases which further lead to lesser conversions. So, this whole algorithm has few major parameters and it is actually a learning algorithm to learn over a certain user and train itself to act for that user in the manner the search is going towards. The parameters involved and the format of how the algorithm works along with the training part explanation is given further.

U (f) - user-selected filter if any

U (ft) - User selected filters tag (For example the laptop would as a filter would result to the tag of electronics)

U (L) - User Geographic Location

U (SL) - User Sub Location

U (PF) - User Earlier Possible Filter Needs (Includes pricing and brands only)

U (H) - User Past History (Used With No Tag and With Tag Both and is a list of past items)

U(G) - User Gender

In Case of No Filter

Recommendation Trainer (RT) Parameters will involve  $[U(L) + U(SL) + U(H - Complete) + U(PF) + U(G)]$  In

Case of Certain Filter

Recommendation Trainer (RT) Parameters will involve  $[U(L) + U(SL) + U(H - U(ft)) + U(f) + U(G)]$  In Case of New User

Recommendation Trainer (RT) Parameters will involve  $[U(L - Prompt) + U(SL - Prompt) + U(H - [L + SL]) + U(G)]$

Now based on the RT being under the vision the algorithm will look first towards the U(L) and U(SL) to know if any certain event is undergoing or if the buy percentage was general or special. By this what it means is like to consider a normal country which does have summer and winter both in strong swings and has no general atmosphere. The item dependency to be bought is more and less placed over the atmosphere and mentality of people in all the seasons which follow there. So, the algorithm will parse through only that location to know if there is a certain event under progress also like Diwali or Eid in India. At times of events

also people have definitely different thoughts. Further for a basic catch, it will move to the most important demographics that is gender as it would give a lot of story about their wants and needs.

Further, once that is done it will extract the information of what are possible items that the user might be trying to buy and then it would go through the history of the user to eliminate any as such items which would be recurring and are normally not bought by user in any recent item but it will again be seen under the trust allocation that is,

Trust Allocation to an item – The items are seen as the possible buy frequency to the time being bought. That is if a person is buying an item recursively that shows the collection habit of a certain item and it will not be eliminated.

Now, once the list is properly filtered again based on if any filters are being put up or not the list is minimalized which would result to more better of the accuracy and pinpointing towards more friendliness of recommendations to the user. For the new users, the system will otherwise generate questionnaire which will include the very basic questions other than general information which must be there to give better accuracy like gender, location and sub-location(if any). The system will look towards items and any event already so it has all the items and along with it the possible tags for the items it will divide the list in the most demanding less demanding and very less demanding item tags. It will show 9 options to the user in terms of that are up for buying any of the items from this possible categories and display first 5 to be the most demanding and then next 2 or less demanding and last 2 of least demanded. This would lead to knowing what user actually wants to buy and then the user will be seen as for some basic pricing options again based on user histories last recorded. Using this basic information the recommendation will be then put up.

Now, this resolves the issue over the side of the user but for the company, the stock management could also be done well by this. As most of the e-tail businesses are known to keep their warehouses in various important location so eliminating as a complete user and considering a new user or past user options for a certain event or general would give the whole idea like the questionnaire being not shown but the analysis of the questionnaire formed to the company owner would lead to a choice of the best stock for any season and get a great profit for the same quarter or year.

#### IV. Existing System

The current system by looks of mostly considering on Amazon is based on collaborative filtering. The collaborative filtering method currently being established is also being backed by enormous data input from behaviour analysis. The behaviour analysis is a part of collaborative filtering actually which looks towards the earlier user history records and also look forward to what most recent they bought. Also, with these personal data being gathered it does put all these as parameters with all the world-wide users of similar configuration management and tries to parse some recommendation. This recommendation has nothing to do with the user being under some event in their country or climatic needs or geographical belongings attached to the user. The need of the user is being completely judged over the factor of generalization and then being converted into any such possible options for the user and show as a recommendation then. The system is not able to analyse the new user other than the demographic to be given as gender which leads to more harder possibility and it might consider the location at times but still it leads to complete generalization which leads to not so good first impression and thus can be termed as inefficient in terms of new user recommendation. The existing system is quite made for providing the answers based on the last possible sales and thus are just providing reports which are data scrambling and not so any logical mapping over it which in turn makes the business owner spend more on data analysts and higher level data scientists and marketing to know what to expect of the upcoming season.

#### V. Proposed System

The system is under talk here is able to parse not by just needs of that user and what they bought in the past. The past is trying to dig up all the possible capture of data that would let us get near to the psychology of the user at the present time. As the psychology of the user is prime importance before letting out any suggestion to the user that they might be looking to buy something. A user is more of connected to any website in terms of loyalty only if they have to spend less time venturing through all the items on the website and get the item as soon as possible. As per the user needs the item might rank in the first place or middle space or even the last spot at times which increase the bounce rate as the loyalty will drop. Also, it does create a bad option for the reference of the website from one user to another. The system is made capable to look towards the more in-depth geographic and interest options for the user to get better results. The system is also looking



forward to any strong and leniency of the user towards any certain filter options to make the whole system more friendly and useful for the user. Also, taking in consideration the proposed system is able to solve the recommendations issues for the new user which was not possible in the existing system and was merely done by generalization alone. The company profit margins are also escalated because now the resulting of the stock is not on the basis on some generalized options but also on the possibility of the events and upcoming seasons to provide more of options and higher profit towards saving unnecessary stock or increasing profit towards less stock at times.

## **VI. Related Work**

Mentioned in the paper [1] it is quite given that collaborative filtering is being used by Amazon and has not been consistent to be able to deliver good results in terms of user satisfaction towards Recommendation. In some other research papers [2] and [3] it was quite known to fact that it was possible to get more of in-depth answers for any user if the more certain study of a user can be done than just looking towards their behaviour in past and possibility of actions based on the history of items they have bought until now. Also, it has been quite clear in the future works that recommendations for the new users are a challenge which is specified with a remark that it stands because a personal understanding of the user is not been properly mentioned while the user is given recommendations. In another paper [4] it is clear that the recommendations shown to any user in format to primary, secondary and tertiary the secondary recommendations are more likely correct but still less than 70% which means there is a higher possibility of loyalty decrease in the user. Also, for the technique involved in the proposed system has been put up under for looking to a block by block construction using swarm intelligence itself and was specified while by Radhika Nagpal [5] in her research founding's shared to the world.

## **VII. Comparison**

Both the system is quite based on the user needs and are completely connected by the demographics but the parameters involved in both the systems differ by larger segments. For, the basic the existing system which is being under work by collaborative filtering is not taking into consideration the climatic or geographical possibilities and also not to mention the events which might be taking place into a certain location also. While on the later part the proposed system is taking in consideration the possibility of demographics like events being under place at the user location and again going in-depth for what is the possibility of sub-location event ways to make sure that diversity of celebration of event is also captured to provide more proper answers and not just on a hunch for a certain event. Also, not to mention that personal psychology is unique for every human being and cannot be generalized and must not be generalized especially on just being of gender and their past history tally with other users past history of similar interest which align with the current user. The existing system is learning the possibility of user psychology on the basis of comparing the gender and then their past history being tallied with other possible users in the database. The similar interests found profiles are then crawled and recommendation is shot up based on generalization on the items list. The proposed system is looking deeply into the user last buy possibilities and also eliminating any recursive possibilities which user is not seen to buy again and again. This leads to further leading to better user attention grab and also since existing system is not looking into repeating any recommendation which might be liked by the user or not the loyalty score is better in the proposed system so bounce rate effect would be seen better in the proposed system. The recommendations must be altered on a filter at least the main ones as it would lead to faster help for user to know what they would like to buy but since the existing system is not looking into a person who is looking to buy an electronic item is having only shoes in recommendations. People do not get annoyed by it at times but sometimes could leave seeing recommendations later dispersing the main reason why they are. In items list, there are some recommendations aligned to the filter but it is not in the basis of the earlier experience of the user in terms of pricing and rating and thus it hits badly on the trust of the user on the recommendation system. While the proposed system does take care of all these possibilities and make better possible options to the user making them feel at home more than even and driving in more trust for the user into the recommendations shown so later even some budget price would be bought by the user to increase sales. The existing system being run over collaborative filtering is not able to judge the possible stock prediction for any region under certain time and thus provide a possible stock prediction which could be good at times. But, at most times would lead to degraded profit since the stock would be more left or less available so it leads to loss of items at times and also at times fewer sales then possible more income which could be hurting to the company in small scale but could be avoided. Also, the users which are actually looking to just buy some products look at

how they feel and work and return them instantly can be avoided by looking the behaviour of them and also the fraud users can be avoided using the proposed system. Not to mention that proposed system is also quite capable to provide better stock options so that the higher inventory stocking in need of time or useless discarding of items in the inventory can be done to provide a higher profit to the e-tail under work.

### **VIII. Future Work**

The research can be further made more exclusive with the needs of users being ranked on more precious factors like the possible social media connections and shared family contacts. To know the wish list and comparing to the search or allowing the feature to look forward a special notification to the user on basis of matching the wish list any item on basis of filtering and date specified by the user expected buy date would result of higher customer retention rate. The user possible parameters more deeply connected to their behaviour and psychology could be always a plus point. The work could be further improved on basis of connecting some special pool of users loveliness that is when users would create their own pool of users and show about how the increase in their trust factor as likeliness impact.

### **IX. Conclusion**

This research was to include that certain parameters being avoided and pushing up only some general data and specific data than to provide the whole lot could also save time and provide more user-specific answers. This would lead to getting better user credibility and trust factor involved to retain users every time and target users towards more of the possible options in the company and gain higher profit levels at the same time. This research has also made itself to be useful to provide solutions towards the new might not be completely efficient but still enough to engage them in the website and let them at least get attached to the business by emotional manipulation by letting them know that we care about their specifics like the demographics and their event going on. Due to specific event handling the overall look change or update push for every possible event is also avoided and letting to focus on all possible for any point of time and not just the most famous event possible on that event.

### **X. References**

1. Nayana Vidaya, Prof. Khachane A.R, Recommender Systems- The need of the E-commerce Era, IEEE 2017.
2. Jicheng Li, Xinyue Huang, Target customer selection method based on data mining in a big data environment, IEEE 2017.
3. Dapeng Liu, Shaochun Xu, Brian Zhang, Chunlin Wang, Chunqing Li, Feng Zhou, Issues with conducting controlled on-line experiments for E-Commerce, IEEE 2017.
4. Hendra, Endang Sulistya Rini, Pahan Ginting, Beby Karina F. Sembiring, Impact of E-Commerce service quality, recovery service quality, and satisfaction in Indonesia IEEE 2017.
5. Prof. Radhika Nagpal, Harnessing Collective Intelligence TEDx Talk, Harvard University
6. [https://en.wikipedia.org/wiki/Collaborative\\_filtering](https://en.wikipedia.org/wiki/Collaborative_filtering)
7. [https://en.wikipedia.org/wiki/Swarm\\_intelligence](https://en.wikipedia.org/wiki/Swarm_intelligence)



# Improving Search Efficiency of Multi Keywords Over Encrypted Data Using Cloud Based Search Techniques

K Varun, C Srinivas, Reddy Jay Sudheer, Mrs. K Karthikayani

Dept. of Computer Science & Engineering,  
SRM Institute of Science & Technology,  
Chennai, Tamilnadu, India

**ABSTRACT:** *As many users store their data in the cloud the provisioning of the data and on-premise IT resources is expensive and cloud providers provides up to date on demand services to the users where they can develop and deploy applications, but when it comes to searching the encrypted data it is a huge process and can be subjected to inside attacks or threats inside the cloud. Since most of the users store lot of confidential data the accessibility of the data becomes very challenging and becomes difficult. Outsourcing the encrypted datasets to the cloud and searching the encrypted files is a very tedious process and leads to huge memory consumption thus reduces the efficiency. In this project we have devised various cloud-based search techniques which can improve search efficiency in terms of file retrieval and how it increases the processing speed achieving near accuracy. The techniques used are K-gram, linear and semantic search. We use blowfish encryption for encrypting the data uploaded as well as performing a ciphertext search. This encryption enhances software efficiency and provides accuracy based on type of search operations performed. A group of keywords are preprocessed from the files uploaded and keysets are generated resulting in different combinations of keywords based on the type of search we are performing. This experimental approach can combat issues such as keyword guess attack, time complexity involved in searching a file, the memory consumption involved etc.*

**Keywords:** *multi keyword, K-gram search, Linear search, Semantic search, Blowfish encryption, Keyset generation*

## 1. Introduction

Cloud computing has evolved over the years, with various technologies and innovations by providing various on-premise cloud-based IT services to the users and it has benefitted huge number of cloud users for a long period of time. Lots of confidential information has been stored on the cloud where searching, processing and speeding up the data becomes the very challenging task. And large number of cloud providers provides access to information to the authorized users with the help of on-premise IT resources and infrastructure. While storing the information cloud users has to outsource the information to the cloud. Maintaining huge amount of data within a cloud is very difficult and it takes huge consumption of memory and it reduces the efficiency in searching and managing the data. This paper is about how we can able to efficiently search and retrieve the file using various cryptographic and cloud search techniques. It also helps in determining the amount of time taken and also estimates the capacity and the speed achieved for processing huge amount of multi keyword stored in the cloud database which contains tons of data and how efficient the search is compared to the existing systems.

## 2. Literature Survey

Distributed computing financially empowers the worldview of information and benefits re-appropriating. To ensure information security, delicate cloud information must be encoded before redistributed to the business open cloud, which makes compelling information extremely difficult. Albeit conventional accessible encryption strategies enable clients to safely seek over scrambled information through catchphrases, they bolster Boolean hunting and are not adequate to meet the successful information usage required that is characteristically requested by huge number of clients and tremendous measure of information records in cloud [1]. Advances in distributed computing and Internet innovations have driven an ever-increasing number of information proprietors to re-appropriate their information to remote cloud servers to appreciate with gigantic information the board benefits in a productive expense. In any case, notwithstanding its specialized advances, distributed computing presents numerous new security challenges that should be tended to well. This is on the grounds that, information proprietors, under such new setting, misfortunes the power over their confidential information. To keep the secrecy of their confidential information, information proprietors normally re-appropriate the encoded organization of their information to the untrusted cloud servers [2]. As in Cloud Computing increasingly humongous data are being unified into the cloud. For the assurance of information security, confidential information more often

than not need to be scrambled before redistributing, which makes compelling information usage exceptionally difficult for undertaking it. But standard available encryption designs empower a customer to securely look over encoded data through catchphrases and explicitly recuperate records of interest, these techniques support only right watchword look. That is, there is no resistance of minor grammatical errors and arrangement irregularities which, then again, are common client seeking conduct and happen as often as possible [3]. As the information delivered by people and endeavors are quickly expanding, information proprietors are spurred to re-appropriate their nearby perplexing information of the executive's frameworks into the cloud for its incredible adaptability and financial funds. In any case, as delicate cloud information must be scrambled before redistributing, which obsoletes the customary information dependent on plaintext watchword look, how to enhance protection guaranteed usage instruments for re-appropriated cloud information is a way for fundamental significance [4]. Programmed content arrangement is a vital segment in numerous data association. Researchers have demonstrated that comparability-based arrangement calculations like K-closest neighbor (KNN) are compelling in report classification. These calculations use record terms to generate reports. One noteworthy downside is that it generally utilizes all highlights when registering the likenesses, which suggests that they should look in a high-dimensional space [5].

### 3. Existing System

A cloud-based search was only applicable with plaintext data where keywords store can easily be retrieved but in terms of ciphertext search it was hugely impossible and there was a degradation in terms of performance and efficiency. In terms of security threats brute force attacks, keyword guessing attacks were existent and due to which data leakage was there and overall architecture was vulnerable to threats. For searching a file only Boolean match query was possible meaning the exact keyword match was possible and even if the users know the file name but have typed it incorrectly the search was not possible. The encrypted search implemented in terms of semantics was not able to derive the closest relationship of the keyword users were searching for as it had same or similar keywords.

### 4. Proposed System

The competent search scheme to search the documents from the cloud server can be done using the nebulous multikeyword set generation. It would create combinations for feasible misspelt keywords, exact keywords and semantic keywords. In the proposed model we are using wildcard-based query handling for handling misspelt keywords and Wordnet tool which can be used for determining linguistics based semantic relationship between keywords. Search keywords would get encrypted and it will check from the collection of original encrypted files uploaded in the cloud server and if the keyword matches then we would connect the nebulous multikeyword set for that particular keyword and it will retrieve the files from the cloud server and we could make an estimation on the amount of time taken for the file retrieved based on the type of search operations performed.

#### 4.1. Proposed System Framework

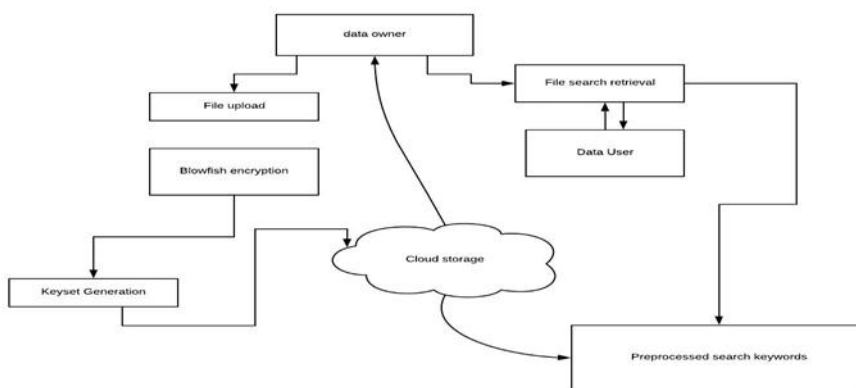

Fig 1: Encrypted Search Flowchart

## 5. System Modules

The proposed system framework for this paper comprises of the following phases as follows

### a. Encryption and Decryption Algorithm

Blowfish: -Here blowfish algorithm is used for encrypting the data as it takes less processing power when compared to other symmetric and asymmetric cryptographic algorithms. It is a 64bit block cipher algorithm and it uses variable length key of 32-448 bits and it is very reliable and efficient in terms of performing search operations.

### b. Admin Module

Login/New User: -Here Admin would be giving the credentials for monitoring or managing the data in the cloud.

Upload File: -In this module, the files which are to be outsourced to the cloud are first encrypted and are uploaded by the admin. Here the files uploaded by admin is of the .txt format and other formats are not supported as the encrypted search is possible with only text document or file.

Keyword set generation: -In this module after uploading the files in the cloud the keyword set is generated in the cloud based on the types of search operations to be performed. Once the keyword set is generated, they are stored in the cloud database and user can perform search based on the keywords present in the database.

### c. User Module

Login/New User: -The user would enter the credentials for authentication of using the IT resources or perform any operations within the cloud. Here cloud users main motive is to search a specific file within the cloud database.

## Search Operations

i. K-Gram Search: -In this module, we perform search based on the missing 1 letter or two letter words and then retrieve the time efficiency for the search that is been made. It uses wildcard-based query handling technique for which different combinations are made for the missing letters and then retrieve time efficiency.

ii. Linear Search: -From the maximum frequent words we enter the exact keyword and then perform a ciphertext search retrieve the file from the cloud server.

iii. Semantic Search: - In semantic search the word which is semantically similar to the keyword is entered in the search box and the keyword which is close to meaning will be fetched and returned back to the user. It uses the wordnet tool which acts as an online dictionary for all the meaningful keywords based on the type of files uploaded and it is semantically similar.

d. Secret key: -When the particular search operation is performed for a file, user can download the data but before that the user has to give the secret key for the file to get downloaded and decrypted. The secret key is sent through the registered mail id and from that secret key is entered and downloaded. After downloading the file, it can be decrypted.

e. Security Model: -In security process, if a hacker or a user tries to enter the secret key three to four times wrongly, automatically the registered mail id will be blocked and he has to register with new mail id to login the user module and get the secret key in order to download the file.

## 5. Graphical Plot and Analysis

The keywords are entered on the search box and time efficiency graph is plotted based on the specific keyword that has been found out from the type of search operation performed. Similarly, it is done for various set of keywords depending on the type of operation to be performed and they are plotted. From this we can make a conclusion on time taken for the retrieval of particular set of keywords and how efficient processing is done for various types of search operation done.

## 6. Results

### 6.1 Admin Module



Fig 2: File upload

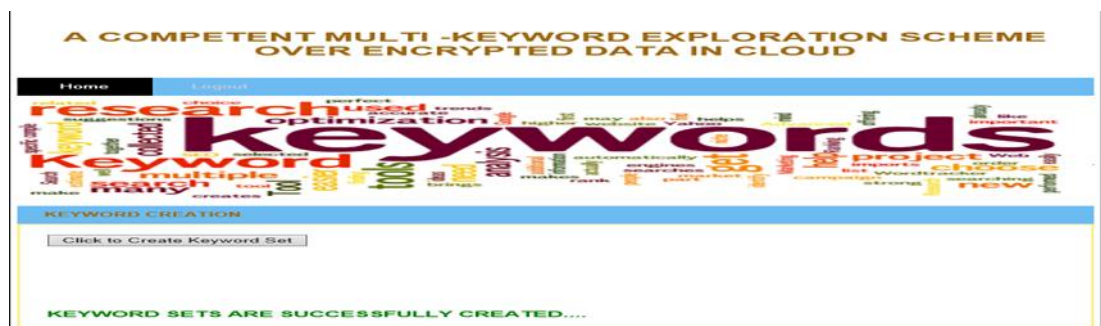

Fig 2.1: Keyword set Generation

### 6.2 User Module



Fig 2.2: Search Operations

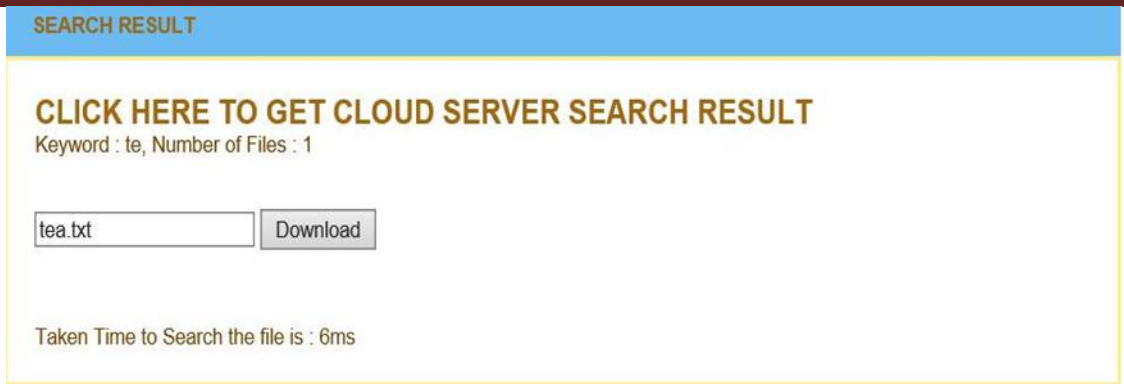

Fig 3: Search module

### 6.3 Graphical Plot

S. No.	File Name	k-gram 1	t1(ms)	k-gram 2	t2(ms)	Linear Search	t3(ms)	Semantic Search	t4(ms)
1	imp	im	12	i	9	imp	8	imp	8
		ip	5	m	0				
		mp	10	p	6				
2	tea	te	8	t	7	tea	5	afternoon tea	7
		ta	7	e	5			tea	7
		ea	7	a	4			tea time	14
3	chair	hair	9	air	7	chair	6	president	7
		cair	6	cir	10			chairman	6
		chir	7	chr	8			chairperson	5
		char	5	cha	7			chairwoman	7
		chai	6					death chair	11

Fig 4: Search Plot Table

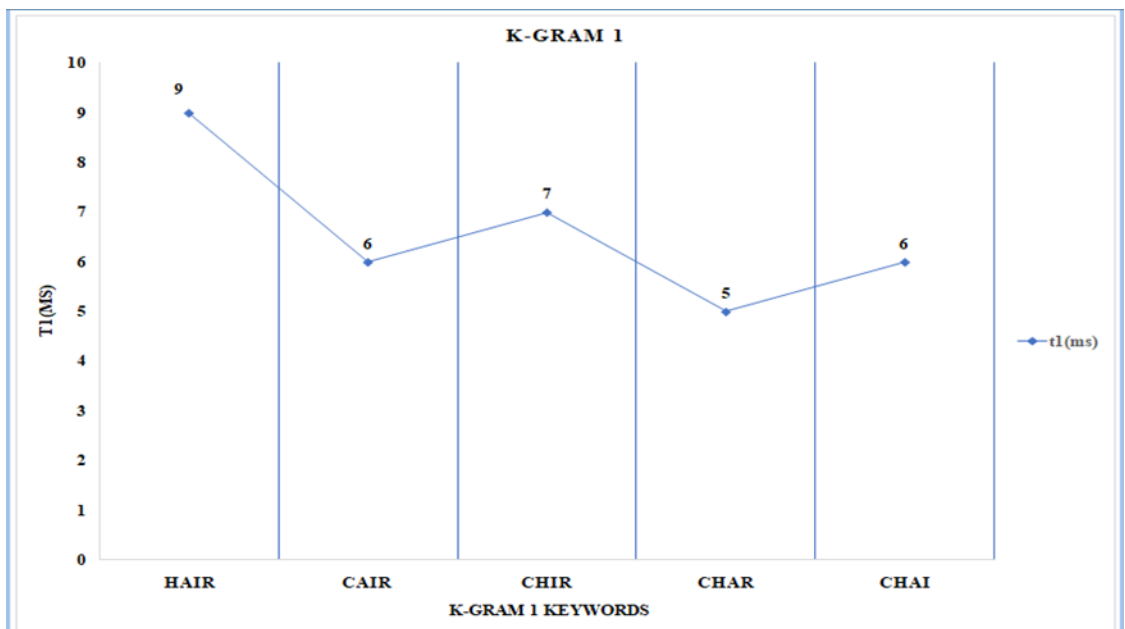

Fig 4.1: k-gram 1 search efficiency graph

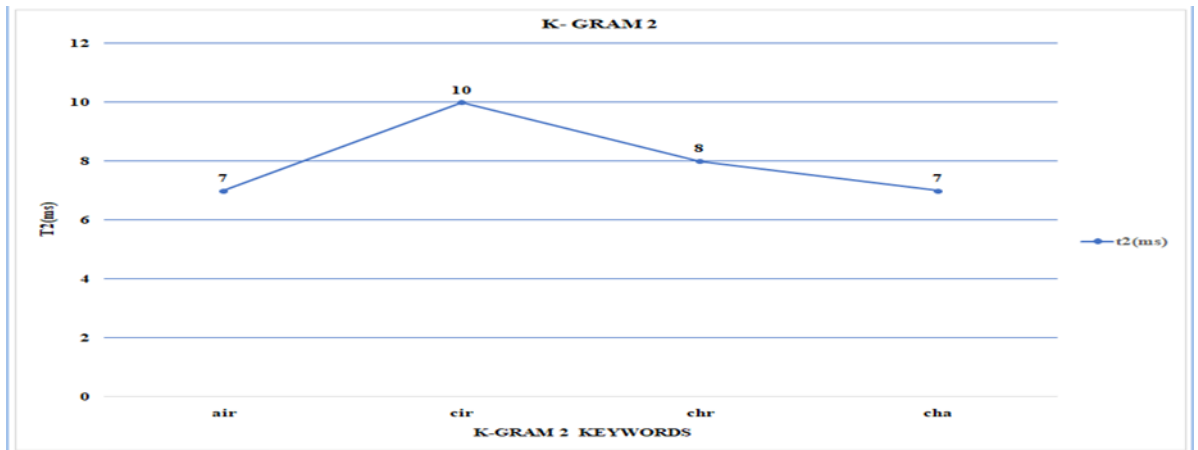

Fig 4.2: k-gram 2 search efficiency graphs

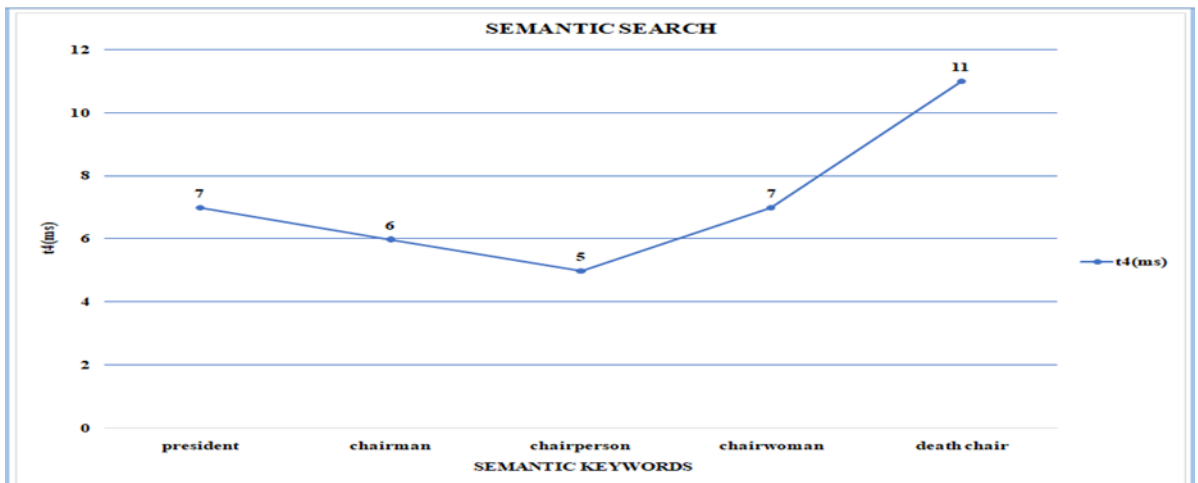

Fig 4.3: Semantic search efficiency graph

## 7. Conclusion and Future Scope

The search algorithms performed on this paper is not close to accuracy but a marginal improvement over existing search-based method. The Blowfish encryption algorithm used enhances the processing speed of the search and thus the efficiency can be attained. In the future we would devise search operations for real time data using the API to compute search operations like we do in real time search engines and also work on the enhanced security model for an encrypted keyword search in a hybrid cloud as it would be a huge challenge in securing data in an IT enterprise or an organization.

## 8. References

1. C.Wang, N. Cao, K. Ren, and W. Lou, "Enabling secure and efficient ranked keyword search over outsourced cloud data," IEEE TPDS, vol. 23, no. 8, pp. 1467-1479, 2012.
2. Ayad Ibrahim, Hai Jin, Ali A. Yassin, and Deqing Zou, "Secure Rank-ordered Search of Multi-keyword Trapdoor over Encrypted Cloud Data," in Proc. of APSCC, 2012 IEEE Asia-Pacific, pp. 263- 270.
3. J. Li, Q. Wang, C. Wang, N. Cao, K. Ren, and W. Lou, "Fuzzy keyword search over encrypted data in cloud computing," in Proc.of IEEE INFOCOM'10 Mini-Conference, San Diego, CA, USA, March 2010, pp. 1-5.
4. C. Wang, K. Ren, S. Yu, K. Mahendra, and R. Urs, "Achieving Usable and Privacy-Assured Similarity Search over Outsourced Cloud Data," in Proc. of IEEE INFOCOM, 2012.
5. B.B. Wang, R.I. McKay, H.A. Abbass, and M. Barlow, "Learning text classifier using the domain concept hierarchy," in Proc. of IEEE International Conference on Communications, 2002.

6. R. Rada, H. Mili, E. Bicknell, and M. Blettner, "Development and Application of a Metric on Semantic Nets," IEEE Trans. System, Man, and Cybernetics, vol. 19, pp. 17-30, 1989.
7. Z. Fu, X. Sun, S. Ji, and G. Xie," Towards efficient content-aware search over encrypted outsourced data in cloud," Proc. of IEEE Infocom 2016, pp.1-9,2016.



# Cloud Computing Security Threats and Challenges

N Saravana Kumar, K Keerthana, Dr.V Dhanakoti

Department of Computer Science and Engineering,  
SRM Valliammai Engineering College,  
Kancheepuram,India

**ABSTRACT:** Software support for the complex system has changed from server to service oriented by cloud computing. This change gives rise to new challenges for design and delivery of services over wide-ranging demands. Due to cloud flexibility all users are relocating their application software and data to remote servers like cloud data centers. The Cloud-access source should be able to provide reliable information services and storage for client data by ensuring data availability, integrity, confidentiality and privacy. This causes some issues correlated with cloud data storage they are, data stealing, data breaches of cloud data. This study identifies the threats and challenges in cloud security and explores the existing solutions to conduct for the pertinent issues in the cloud.

**Keywords:** Security, server, data breach, availability, integrity, confidentiality, privacy.

## 1. Introduction

Cloud Computing has grown from virtualization, business and distributed computing technologies [1]. Cloud is actually a physical data center located remotely on the globe. These remote data centers form a large resource pool thus providing virtualization. Virtual machines are hosted on top of this large resource pool to provide services for the customer. Applications of large organization requires more reliable services like availability and scalability which can be fulfilled by cloud computing. Cloud computing is an innovative structure that reformed the organization software and hardware design and services. Resource elasticity, Pay-as-you-go services, easy-internet-access etc., are valuable services offered by cloud computing technologies. For rise in business links all minor and huge corporations are surge towards cloud computing. Though cloud computing offers more valuable customer services still the data are vulnerable. Data owners are reluctant to place their private or delicate data, like administration related records, private health records and mails. After uploading data to the cloud, the cloud customer or owner of the data loses direct influence over that data. NIST [2] states that Cloud model offers suitable on-demand network access to configurable shared resource pool that can be rapidly provisioned and released with minimum provider effort.

The Cloud-access source should have reliable security approaches such as virtualization and firewalls for data stored in cloud clients. Cloud-access sources has complete control over cloud data, hardware and applications. Firewalls and virtualization could not be able to offer over-all protection of client data due to its weakness over the system.

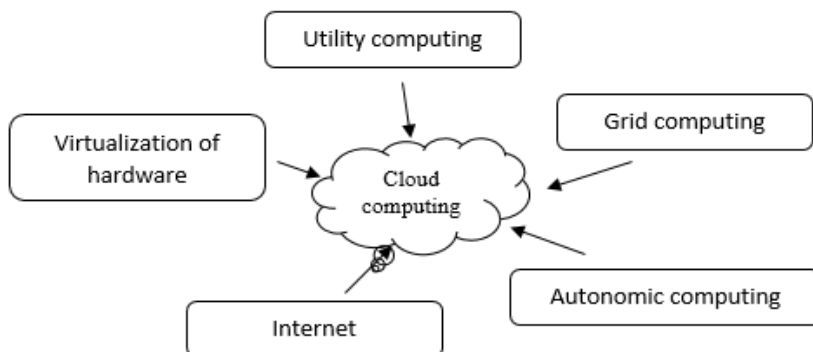

Fig. 1 Cloud Computing

Another security approach that ensures confidentiality and privacy of data in cloud-access source is encrypting personal and important organization data before introducing it to the cloud. Due to enormous volume of overheads in communication over the patterns of cloud access encryption is unfeasible. Hence, to uphold the data privacy and confidentiality cloud should propose more secure approaches for data storage and administration. This study focuses on security weaknesses and threats in privacy and confidentiality over customer data.

## I. Cloud Fundamentals

The basic information regarding the cloud computing technology is described according to the survey paper [3].

### 2.1 Deployment Types of Cloud

**Private:** Private clouds exists as off-premises or on-premises that is maintained and administered by a company or a third-party. This cloud model is not available for common audiences since it is an interior data center owned by the company. It is solely exploited by the company using multi-tenant framework. Maintains confidential data of organizations and personal data of client etc.

**Public:** Public cloud is a on-premises cloud provider that is maintained, administered and run by academic, business and government companies. Outsiders enjoy the public cloud using pay-as-you-go approach.

**Community:** Community cloud exists as on- premises or off- premises that is maintained, administered and run by any company related to the community or a third-party. It shared by two or more companies and supports a particular community which has similar goals.

**Hybrid cloud:** Hybrid cloud is a mixture of more than one cloud i.e. public, private and community. This is particularly designed to handle cloud bursting.

### 2.2 Features of Cloud

**On-demand self-service:** This feature allows the customer to make prearrangement based on his demands regarding the cloud services with access provider. On-demand self-service permits the clients to configure and attain cloud sources without human intervention.

**Broad network access:** Varied client platform can gain access to cloud facilities and resources since they are available over a existing networks. Tabs, laptops, workstations, cell phones are some customer platforms that can access cloud facilities using certain typical procedures.

**Resource pooling:** cloud hosts pooled resources to support multi-tenant environment. Data uploaded to cloud can be accessed from anything and anywhere irrespective of time and location.

**Rapid elasticity:** Since cloud hosts pooled resources those resources can be scaled according to the client requirements.

**Measured service:** Cloud models make the customer pay only for the facilities they used. It measures and reports the amount of used resources to the client thus ensuring openness to both clients and access providers.

### 2.3 Services offered by Cloud

**Infrastructure as a Service:** Infrastructure as a Service (IaaS) is the base layer of the cloud computing stack. Storage, and communication are virtualized and presented to customers based on their demand. Some examples of IaaS are GoGrid, Amazon Elastic Compute Cloud (Amazon EC2), Rackspace, Joyent, Flexi scale cloud.

**Platform as a Service:** Platform as a Service (PaaS) made easy to program cloud by offering a higher level of abstraction. Cloud platform is an environment where programmers build and deploy created applications without any knowledge of any underlying memory, processors or hardware that applications use. Some examples of PaaS are Amazon Web Services Elastic Beanstalk, Microsoft Azure, Google App Engine, etc.

**Software as a Service:** Software as a Service (SaaS) is the top layer for applications on cloud stack. Services offered by SaaS are accessed through Web portals by corresponding clients. Some examples of SaaS are Face book, Quora, Twitter, Gmail, Instagram etc.

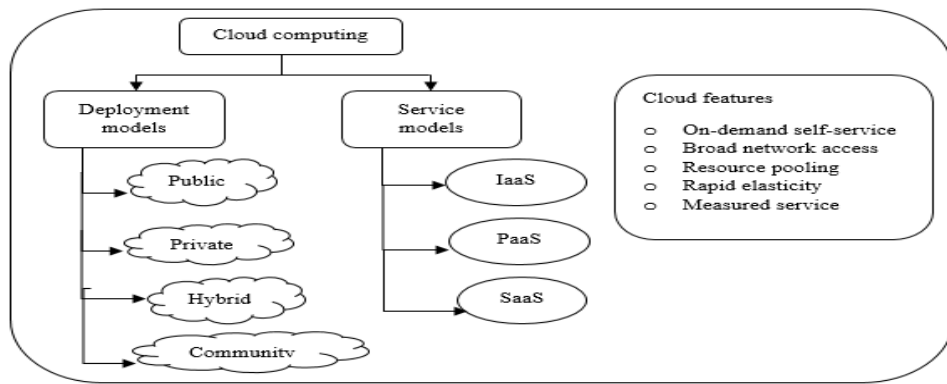

Fig. 2 Basic cloud model

### III. Cloud Computing Security Challenges and Threats

The following describes challenges and threats regarding corresponding cloud areas also the secure cloud hazards and challenges based on cloud security alliance [4,5] are described.

#### 3.1 Challenges and Threats in Cloud Deployment Models

The three basic deployment models are Public, Private and Hybrid. Public clouds are open to access resources, applications, and services over any network. Private clouds are commonly deployed inside a company and can only be accessed by company employees. Hybrid cloud is the mixture of above cloud deployment models serving multi-tenant environment.

The common challenges found in deploying above three models are shared multi-tenant environment, authentication and identity management, resource pooling and cloning, elastic perimeter, data residuals and motility of data and unencrypted data. These challenges impose risks in cloud deployment like trusting data to people and processes, viability of cloud vendor, malicious insiders and insufficient due diligence.

#### 3.2 Challenges and Threats in Cloud Service Model

Cloud services like PaaS, SaaS, IaaS are presented to clients over the cloud. PaaS gives a platform for programmers to build and test applications without any concern about underlying features. PaaS offers some control to programmers creating apps on its platform. PaaS does not ensure programmers about intrusion prevention or the risks in network. SaaS is a multi-tenant environment usually an application access provider serving distributed services to cloud customers. IaaS offers developers a complete control over the app including underlying features like storage, hardware etc.

There are some challenges in cloud service models like service hijacking, man in the middle attack, virtual machine hopping, data leakage, data storage, backup, malicious attacks, shared technological issues. These challenges impose some threats like cloud security violation, abuse of cloud services, legal and regulatory compliance and denial of service.

#### 3.3 Challenges and Threats in Cloud Network Model

To preserve data for running varied apps cloud computing technology relies on internet and remote data servers. Virtualized resources, high bandwidth and applications software are presented to consume based on their demand. This network cloud system encounters several varied security and attacks issues like cloud malware injection attack, DNS attacks, browser security issues, flooding attacks, sniffer attacks, locks-in, reused IP problems, incomplete deletion of data, data protection, XML signature element wrapping, SQL injection attacks and Cross Site Scripting (XSS). The threats include Failure in provider security, attacks by other customers, Data loss and Shared technology vulnerabilities.

#### 3.4 Challenges and Threats in Cloud Application Model

Cloud presents reliable and secure data server for storage of client data. It enables sharing data among various entities relying on the network. Any number of users can access over internet. Cloud is easy to handle and no need of complex devices. The application level challenges in cloud include hypervisor security, cookie poisoning, hidden field manipulation, backdoor and debug options, denial of service attacks, captcha

breaking, dictionary attacks and search engine hacking. These impose dangers such as availability and reliability issues, protection of data, data confidentiality, data breaches, traffic hijacking and unprotected interfaces and APIs.

**IV. Security issues in Cloud**

**4.1 Issues in Data Storage**

Despite having many advantages such as cheap and reduced resource management, cloud computing has its own security threats. As mentioned earlier, cloud computing must provide security measures in terms of confidentiality, integrity, availability of data and privacy in generic cloud computing model but instead poses threats in terms of the above given conditions.

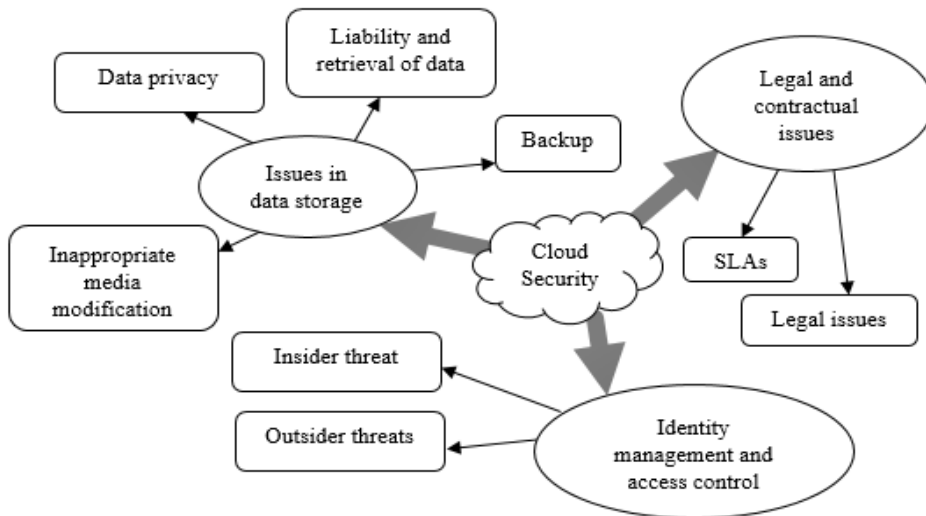

Fig. 3 Security issues in Cloud

**4.1.1 Data Privacy**

Given the simplicity of cloud computing the rate of users are increasing in a alarming way and the data stored in cloud is also high. This provides a greater percentage of security threat to cloud users. If the data entity is successfully attacked, then there would be a data breach which would to unauthorized access of data by unprivileged users. If integrity violation of cloud data occurs, it would lead to the loss of multitenant nature of cloud computing. Particularly the SaaS providers [6] may be subject to damage of technical data and have danger of data storage. Asides these damages, when multi tenants transfer data among themselves it would lead to high risk in data processing. While other customer processes their data, these situations may allow the malicious user to perform attacks on stored data. Keygeneration and management using cryptography for cloud computing is not up to the mark. Due to this, the cloud doesn't consent the standard cryptography algorithms to finely work in generic cloud. These provide potential risks to cloud computing.

**4.1.2 Liability and Retrieval of data**

Queuing to the factors of resource pooling and elasticity characteristics, the cloud ensures dynamic and on-demand Resource provisioning to the cloud users. At some later point of time, resource allocated to a particular user may be assigned to the other user. An unprivileged user can employ data recovery techniques to obtain the data of previous users [7], in case of memory and storage resources, of the times. The data recovery vulnerability can be a major threat to the sensitive user data.

**4.1.3 Inappropriate media modification**

The storage devices are to be cleaned frequently because first, the physical disk needs to be replaced with another disk. Then, secondly no longer needed to maintain the disc and finally pause of all services. Improper cleaning of data ensures greater risk to storage devices. In a multi-tenant environment, it is not possible to refine the disc as like the previous tenant.

#### 4.1.4 Backup

Backing up of data are essential in times of accidental or intentional damages. Cloud service provider has to perform regular checks and take backups of stored data to ensure the data availability. The backup data should be kept within security guidelines to prevent malicious activities such as tampering and unauthorized access.

#### 4.2 Identity Management and Access Control

The confidentiality and integrity of data services are related to access control and identity management. It is inevitable to track records for user identity for avoiding unauthorized access to the stored data. The access and identity controls are complex in cloud computing, and because of that the data owner and stored data are at different executive platforms. In this environment, different providers use various authentication and authorization agenda. By doing so, they give a compound situation over a period of time. These cloud resources are elastic and dynamic for cloud users and their IP addresses are continuously changed when services are started or restarted in pay per usage model. This allows the users to join and leave the cloud resources whenever they deem necessary that in other words referred as, on-demand access policy. All these facilities need efficient access control and identity management. The premise has to maintain quickly updating and managing identity management for joining and leaving users over cloud platforms. There are still pertaining issues in access control and identity management, for example not so strong credentials would reset easily, denial of service attack, in uniform logging and monitoring abilities, and XML wrapping attacks on web pages.

##### 4.2.1 Insider Threats

When considering insider threats, they can be posed by employees, contractors or third-party business partners of an outer organization. From the provider side attacks leads to loss of user's information confidentiality, integrity, and availability of data. This would lead to data loss or breaches at both environments. This attack is well known to most of the organization [8]. There is a variety of attack patterns followed by insiders due to the sophistication of internal structure in an organization's data storage structure. Most of the organizations ignore this attack since it is very hard to identify and prevent and mere impossible to find the complete solution for this context of attack. This method ensures greater risk in terms of security breaches and data loss confidentiality in both sides and cloud level [9].

##### 4.2.2 Outsider Threats

Security breaches that come from external origins are called outsider attacks [10,11]. Security is one important issue in cloud computing platform. Just because the service providers do not have permission for access to the physical security system of data centers, this has become a high-risk issue. Still, it depends on the infrastructure provider to get full data security. In a private cloud platform, the cloud service provider can specify the security setting remotely, but we don't know what exactly are those that are fully implemented. In this methodology, the service provider must reach the objectives which are confidentiality, for secure data transfer, and tracking records. So that external intruders are not able to access sensitive data which is stored in cloud.

#### 4.3 Legal and Contractual issues

After moving back to cloud computing environment, there are still many issues in geographic sections, regular law, performance competency, contract enforcements, etc. The above given situations come under the legalities, Service Level Agreements and data location in data centers [12].

##### 4.3.1 Service Level Agreements

The Service Level Agreement (SLA) can be briefed as a highly given set of instructions, that specifies the set of conditions and terms among users and cloud service providers. The SLA would list down the following steps: Actions that the CSP will take care of when data breach happens, remedial actions and performance level checks at the minimum [6] possible level. The cloud users should have clear cut idea on how the security for their resources and all other requirements are to be agreed upon by the SLA. The contract management becomes an issue since the statistics provided by CSP are totally not based on facts.

On the last note, the contracts are non-negotiable and template that it has to be in a friendly manner between cloud user and CSP. The judicial laws such as Sarbanes- Oxley and HIPAA becomes an issue in the case [13].

#### 4.3.2 Legal Issues

The legal issues come up because of the presence of CSP resources in geographically conflicting legal laws [14]. If the cloud user gets migrated from one geographical to other, it'll become an issue of different legal jurisdictions. For the movement of data is distributed over variety of data centers, those owned by CSP have different laws and security measures. This situation may result in serious issue in cloud computing.

#### 4.4 Information Security Principles

There is a list of principles that needs to be followed so as to have a risk-free cloud platform. These measures are referred as Information Security Principles. CIA is a widely known security model that deals with vehement aspects of cloud security. This is used to in-order to identify the security problems and provide combined necessary solutions. According to the CIA, C means Confidentiality, I mean Integrity and A stands for Availability [14]. These security measures are also discussed below

##### 4.4.1 Confidentiality

Confidentiality means protecting the data from unprivileged users. Its main focus is to make sure that the information is protected from unauthorized users to use it. Due to the alarming increase in number of cloud applications and equipment, security risks also increase that leads to an increased number in access points.

##### 4.4.2 Integrity

Integrity defines the consistency and accuracy of information stored in cloud. This data in cloud should not be modified by any unprivileged user or in an unprivileged manner. It says that information should not be changed/alterd in transit.

##### 4.4.3 Availability

The principle of availability states that the cloud data must be available whenever and where verities needed. It means that the property and the system must be usable and accessible whenever requested by the compatible users.

#### 4.5 Requirements for Secure Cloud

Just before migrating the data to cloud platform, security is not the only requirement considered. Third party organizations are not only in need of security, but also robust security that can be trusted and monitored. Thus, we list out the three basic requirements of secure cloud [16].

##### 4.5.1 Strong Security

Strong security means moving across the traditional modes. Although we are in a shared multi-tenant cloud environment, robust security ensures secure isolated storage of data. This would ensure protection of data at all the different layers in cloud platform. This also includes procedures in order to provide access control and confidentiality.

##### 4.5.2 Reliance and Guarantee

In Reliance and Guarantee, the third-party association should maintain a confidence in the integrity of data and entire cloud infrastructure. This again includes integrity all of hardware, data centers, software, processes etc. The cloud service provider is in need to provide an evidence-based trust architecture for the cloud environment that involves the monitoring and reporting capabilities that would in turn ensure the cloud customer about the transparency related to security vulnerabilities. This would involve audit records further to deal with customers foreboding problems.

##### 4.5.3 Control and Supervision

This would involve methods and resources that allow cloud customers to track and record the security platform, performance and reliability. With the use of these properties, cloud customers can monitor those activities as they could in their own datacenter. With the help of these utilities, customers are allowed to take necessary actions on account of the security information received from the cloud provider. Such actions may include shutting down the cloud application itself. Control on part includes risk assess management.



#### 4.6 Cloud Security Controls

Cloud Security Controls can be viewed as a three-layered model. They include Frontend, Middle and Back End Security.

- i) Front End layer deals with authentication and authorization.
- ii) Middle layer deals with virtual machine security and system security.
- iii) Back End layer deals with network security, database security and storage security.

#### 4.7 Security Architecture

The architecture of security includes confidentiality, isolation and access control that are necessary requirements to protect information and applications of a third-party organization [16].

- i) Isolation: Ensures separation of data within a multi-tenant environment. Its attack measure would be the use of hypervisor that enables multiple data centers.
- ii) Confidentiality: An important component of cloud system architecture that provides protection of the information from unauthorized access. Their counter measure for confidentiality is 'Encryption'.
- iii) Identity Management and Access Control: Ensure that only privileged users can gain access to the applications, which involves audit and log record management. Identity management and access control can be given by 'Federated Identity Management'. Along with this, validation processes can ensure identity and access control.

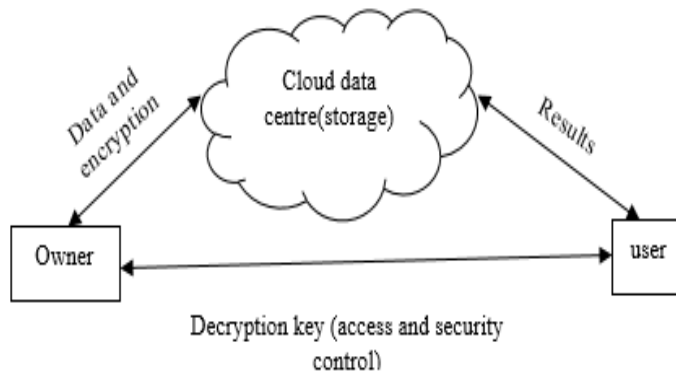

Fig. 4 Basic secure architecture

#### V. Conclusion

The security issues that pertain with the data storage such as confidentiality, integrity and availability are discussed in this study. Further we have focused on data storage security and its related issues in cloud computing and provided service models of cloud, deployment models and variety of security measures that can be followed in data cloud environment platform. With the growing technology advent, cloud computing is an important computing paradigm and has been dominating the IT market for the past 20 or so years. Further drifting towards cloud computing would be seen in the future owing to its features and benefits. The issues with security and data storage such as confidentiality, integrity and availability would be taken care of in near future and this field of cloud computing platform would prove to be one of the best knowledgeable and growing centers that we have seen in the past 2 decades.

#### References

1. Wentao Liu, Research on Cloud Computing Security Problem and Strategy, 978-1-4577-1415-31121 ©2012 IEEE.
2. P. Mell, T. Grance, The NIST definition of cloud computing (draft), NIST Special Publ. 800 (145) (2011) 7.
3. Tunisha Saxena, Vaishali Chourey, "A Survey Paper on Cloud Security Issues and Challenges", IEEE, 2014.
4. Rohit Bhaduria, Rituparna Chaki, Nabendu Chaki, Sugata Sanyal, "A Survey on Security Issues in Cloud Computing and Associated Mitigation", International Journal of Computer Applications (IJCA), June 2012, pp: 47 - 66.



5. Ms. Disha H. Parekh, Dr. R. Sridaran, "An Analysis of Security Challenges in Cloud Computing", International Journal of Advanced Computer Science and Applications (IJACSA), Vol. 4, No.1, 2013.
6. C. Wang, Q. Wang, K. Ren, N. Cao, W. Lou, Toward secure and dependable storage services in cloud computing, IEEE Trans. Services Comput. 5 (2) (2012) 220–23.
7. O.D. Alowolodu, B.K. Alese, A.O. Adetunmbi, O.S. Adewale, O.S. Ogundele, Elliptic curve cryptography for securing cloud computing applications, Int. J.Comput. Appl. 66 (2013).
8. Duncan, Adrian, Sadie Creese, and Michael Goldsmith. "Insider attacks in cloud computing." Trust, Security and Privacy in Computing and Communications (TrustCom), 2012 IEEE 11th International Conference on. IEEE, 2012.
9. Khorshed, MdTanzim, ABM Shawkat Ali, and Saleh A. Wasimi. "A survey on gaps, threat remediation challenges and some thoughts for proactive attack detection in cloud computing." Future Generation computer systems 28.6 (2012): 833-851.
10. Reddy, V. Krishna, B. Thirumala Rao, and L. S. S. Reddy. "Research issues in cloud computing." Global Journal of Computer Science and Technology 11.11 (2011).
11. Patel, Ahmed, et al. "An intrusion detection and prevention system in cloud computing: A systematic review." Journal of Network and Computer Applications 36.1 (2013): 25-41.
12. A. Andrieux, K. Czajkowski, A. Dan, K. Keahey, H. Ludwig, T. Nakata, J. Pruyne, J. Rofrano, S. Tuecke, M. Xu, Web services agreement specification.
13. S. Marston, Z. Li, S. Bandyopadhyay, J. Zhang, A. Ghalsasi, Cloud computing the business perspective, Decis. Support Syst. 51 (1) (2011) 176–189.
14. B. Hay, K. Nance, M. Bishop, Storm clouds rising: security challenges for IaaS cloud computing, in: 44th Hawaii International Conference on System Sciences (HICSS), IEEE, 2011, pp. 1–7.
15. Mircea Georgescu, Natalia Suicirnezov, "Issues Regarding Security Principles in Cloud Computing", The USV Annals of Economics and Public Administration Volume 12, Issue 2(16), 2012.
16. M. Drozdova, S. Rusnak, P. Segec, J. Uramova, M. Moravcik, "Contribution to cloud computing security architecture", ICETA 2017-15th IEEE International Conference on Emerging eLearning Technologies and Applications Proceedings, 2017.

---

# IOT Based Smart Charger Using Wifi Micro-Chip

S Manohar (AP), Arunkumar S, Manikandan P, J Vishal Karthick

Department of Computer Science and Engineering,  
SRM Institute of Science & Technology  
Tamil Nadu, India

---

**ABSTRACT:** *There are many applications of the Internet of Things; adding to one of them is the observing of smartphone charging adapter system. By the usage of IOT we design the energy efficient device, which reduces equally, the power consumed by the smartphone and the human efforts essential in that procedure. The smart-charger system has been intended to implement a smart charging system that automatically controls the behaviour, performance and output of the charging adapter using time as an important constraint. In this project, we have introduced the usage of efficient Arduino UNO and ESP8266 boards to implement the solution for the existing charging adapter. The Smart Charger solution considers the switch-over of the power supply to an attached power-bank in the circuit, once the smartphone has been fully charged. Through this method we will be able to use the switch-on (power-socket) time to charge the power-bank, which can in-turn be used as a power-backup. Majorly, this implementation work, will make sure that whenever there is no power from the socket to charge the phone, automatically the power-bank will provide power supply to charge the smartphone.*

**Keywords:** *IOT, Arduino, ESP8266, Power-bank, Smart Charger.*

---

## 1. Introduction

Throughout the world there are about 4.5 billion smartphones, smart-tablets, and other smart devices. These smartphones and smart-devices are charged on a daily-basis using the charging adapters, and eventually due to human errors (not switching off charger, forgetting to unplug phone, and other such situations), there is a lot of power loss. The switch-over from normal chargers to this smart-charger will allow the electricity wastage to be reduced to near zero levels. The characteristics of this device is that it could monitor the power consumption and control it, and will help vastly in reducing the wastage of energy. The smart-charging system would be proficient of switching on and off only when the device to be charged is connected and charge only when needed, and can be additionally developed to monitor other appliances. There are numerous modules accessible, which when paired up with the smart-charging circuit will enhance the charger into an IOT centred device; such devices include the boards like ESP8266, relays and other Arduino based Wi-Fi modules.

### 1.1 Existing System

The architecture description of the existing system is as follows. When the charger is connected to the power-socket the initial step of the existing charging system is the stepping down of the high two hundred and thirty volts to a stable nine volts. In the existing stepping down circuit, there are two prime coils present, which are important in stepping down the voltage with relevance to the number of turns in the given coils. The selection and usage of a proper transforming circuit is very much important and is also a requirement. Now, the current rating depends upon the current requirement of the load circuit (circuit which uses the generated DC). Here, rectification is the course of removing the negative part of the fluctuating Alternate Current (AC), hence producing the fractional DC. Finally we require a voltage regulating device at the output side in order to maintain the rectified constant voltage throughout.

This existing system method is having a main circuit in which there is a single connection from the charger output to the smartphone which is to be charged. This single power-line is always switched-on, not taking into account whether the smartphone requires the charge or does not require it. The output of the existing system is that the smartphone is fully charged. But the power-socket is switched on even after the smartphone has been fully charged. This human or default-error makes it a huge drawback in today's rising technological world, to not make a breakthrough in making the charger smart and on par with the smartphone. The drawbacks or the limitations in the existing system are as follows. The power is wasted (considering the switch-on time) after the smartphone has been fully charged. The switch-on time has not been used for any other purpose. There are chances of the smartphone's battery getting damaged by overcharging or by other electrical terms. This power limitation has not been solved or brought down to any level.

## 1.2 Proposed System

In this section, the explanation of the smart-charger system, are in detail. Here the enhancements and addition to the charging circuit by using the IOT implementation are proposed. Here, we have introduced the usage of efficient Arduino UNO and ESP8266 boards to implement the solution for the existing charging adapter. The solution considers the switch-over of the power supply to an attached power-bank in the circuit, once the smartphone has been fully charged. The primary aim of this proposed system was to achieve the constant power-supply to the smartphone which is charged, and also transfer the excess power being supplied to a connected power-bank. Through this method we will be able to use the switch-on (power-socket) time to charge the power-bank, which can in-turn be used as a power-backup. Mainly, this prototype implementation work, will make sure that whenever there is no power from the socket to charge the phone, automatically the power-bank will provide power supply to charge the smartphone.

## 2. Components

### 2.1 ESP8266

The ESP8266 is a micro-controller which has a Wi-Fi module which can connect to any IOT based platform [1]. It is a low cost microchip. It is a highly efficient Wi-Fi module that can run on 3.3v of power. It's an open source and can be programmed with the Arduino Uno board. The ESP8266 module contains a stack for HTML, JAVASCRIPT, XML, CSS, etc. and supports implementation of various API's. The ESP8266 is also widely used to store cookies and authentication processes. With the ESP8266 local Webservers are readily created and remote implementation is carried out by port forwarding using the router's static IP. The controller shown below, is the one used in this project implementation.



Fig. 1: ESP8266

### 2.2 Arduino Uno

The Arduino Uno board is used here as the core circuit controlling board. Arduino is an open-basis physical computing device which is based on an implementable input/output board and it consists of a development environment that implements the processing/programming language. The available Arduino Uno Rev3 is a microcontroller board established on the ATmega328. Constructed and made available in it are 14 digital input/output pins of which the first 6 are entitled for PWM outputs, the next 6 for analog inputs, with an additional 16 MHz crystal oscillator, along with a USB connection for uploading program codes; a power jack for powering the board, an ICSP header, and a reset button for carrying out the operations from the beginning. The board contains all components necessary to support the microcontroller; we simply connect it to a computer with a supported cable to simultaneously power it to get it started with [2]. The main usage of this board in our project is to monitor the power output and to control the relay module and the ESP8266 module.

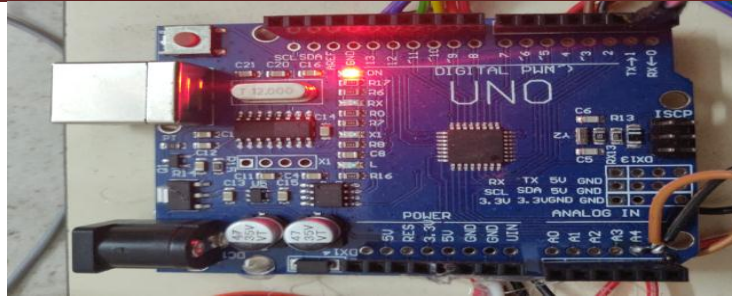

Fig 2: arduino uno board

### 2.3 Relay Board

Relays are generally defined as switches that are used for opening and closing circuits electromechanically or electronically. Basically, relays are used to switch control from one electrical circuit to another by opening and closing interactions in another such circuit. If any relay contact is in the state of normally open (NO), then there is said to be an open contact when the relay is not specifically having an energized interaction. When a relay contact is in the state of normally closed (NC), there is said to be a closed contact established when the relay is not having an energized specification. In either case, applying any electrical current to interact with the contacts will change their existing state. By principles, relays are commonly under implementation to carry out the operations of switching relatively small units of current in an operational circuit. By various studies, relays are found to interact with larger units of voltages and amperes similarly, by having a magnifying effect due to reasons as, a small voltage functional to a relay coil can have an effect on large units of voltage being switched by the operational interactions.

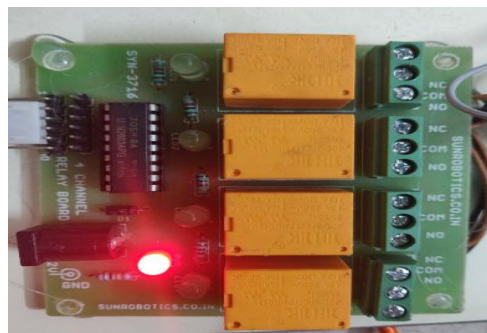

Fig 3: 4-Way Relay

Here, for our project, the smart-charger, we have used the 4-way relay segment. The 4-way relay segment is an electrically activated switch that allows us to govern, that is, to switch on or off a circuit by means of altering the voltage and/or current much complex than a micro-controller could take through. Here, there is no available connection through the low voltage circuit functioned by the micro-controller and the elevated power circuit. The function of the relay here is to protect each and every circuit connection from one another. Here, each and every connection channel in the segment has three interactive connections, namely the NC, the COM, and the NO. This network can be controlled by giving the desired input signal. Reliant on the input received signal trigger mode, the necessary component can be positioned at a high level operative mode which gives way for the closing of the normally open (NO) pin at a relatively greater level of input and at a low level operative mode which works the same but at low level of contribution.

### 2.4 Display

The display screen is an electronic display segment which is basically included as a component to print the desired output through program codes. Here we use a 16x2 display, which is an elementary unit and one which is very commonly used in various devices and circuits. These segments are favoured over [seven segments](#) and other multi segment devices. The motives being that these are efficient; effortlessly

programmable; have no restriction in presenting special, even [custom characters](#) (unlike other devices), [simulations](#) and so on.

This device and its properties allow it to present sixteen characters per line and there are two lines available. In this device, each character is displayed in five multiplied by seven pixel matrix. The device has two registers, the command and the data. The first one, command stores the command or instruction input fed to the device. The command includes instructions that are specified to the display device to do a predefined task like preparing it, clearing the screen, setting the cursor position, controlling the display and more such operations. The second register, data stocks the data to be presented on the device. The details to be displayed should be given as the numerical value of the corresponding stock to be presented on the screen.



Fig 4: LCD Display

### 3. Working Description

The smart-charger components were combined to form the major circuit of the project. Firstly, the working flow of the project was designed. Now, this circuit had a proper working flow. This working flow was based on the steps which formed into a flowing algorithm. The flow diagram is as depicted below.

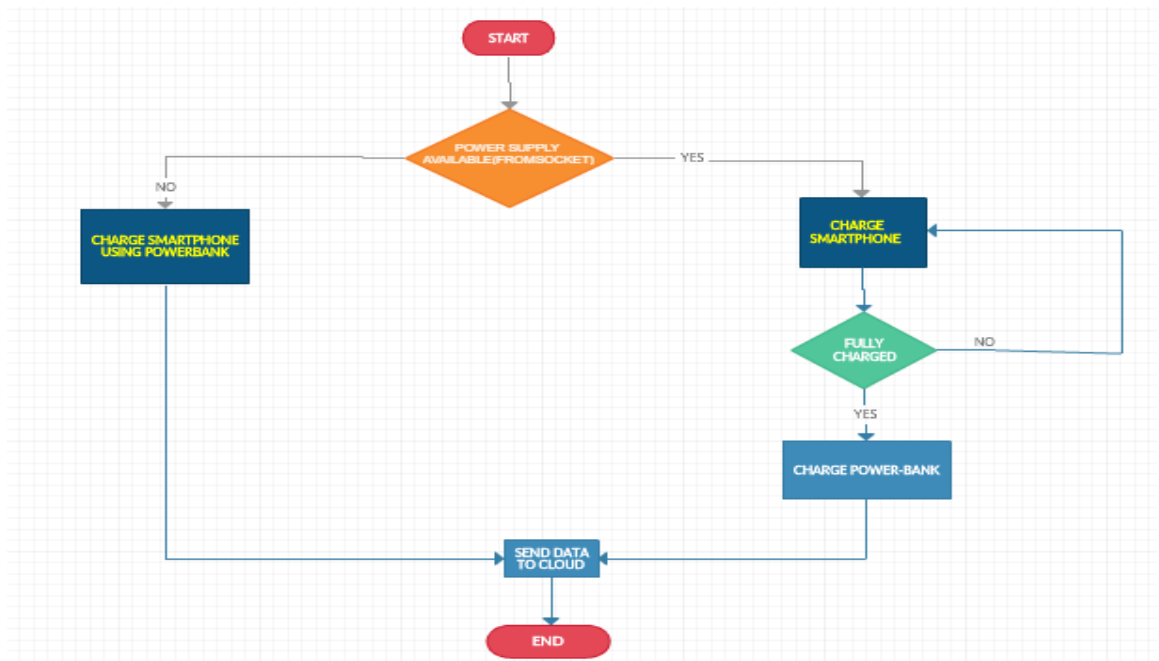

Fig 5: Working Flow



The architecture of the whole module, considering it as a single flowing circuit, was built using the Proteus [3] software tool. The architecture was implemented as per the planned design using the components. The whole architecture designed is as below.

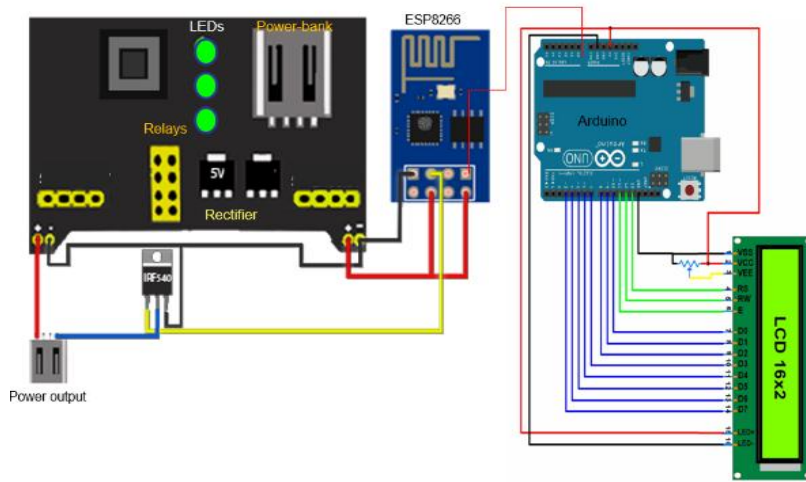
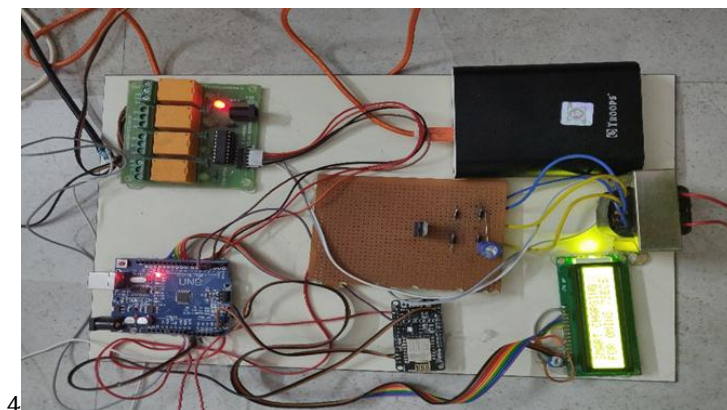

Fig 6: Architecture

The given architecture is a basic one and was drawn for understanding and perceiving the can be divided into different and smaller modules for easier explanation and understanding. The first module consists of the circuit drawn and connected from the arduino uno board to the relays. The second module consists of the connection from the arduino uno to the ESP8266 chip and the LCD display. Here, we consider and take the Wi-Fi chip and the display in the same module, as the dataset sent from the arduino uno for the two are the same. The third module in the architecture consists of three circuits, where the first one is a connection from the relay board to the smartphone; the second is the connection from the relay to the power-bank, and the final third circuit being the connection from the power-bank to the smartphone. All the three circuits in the third module are monitored and controlled through the four-way-relay by means of the core circuit of the arduino uno and the relays.

#### 4. Implementation

In this section the implementation of the smart-charger architecture and the working section are carried out. The hardware circuit of the smart-charger has been assembled with the virtually constructed architecture, which is in figure (5). The implemented hardware circuit is explained as different modules, for better clarity of understanding of the whole smart-charger.



4

Fig 7: Implementation

### I. First Module

This consists of the circuit from the arduino uno to the four-way relay board and the LCD display. Now, the working implementation of this module, is as follows. The arduino uno board is programmed to monitor the power output of the whole circuit. The power supply that is monitored by the arduino is given by the MB102. The MB102 is a basic charging circuit which is required in the module to support and regulate the power supplied to all android devices. It is used to observe whether the power which is taken as output is five volts or below. If the output is five volts, then it controls the 4-way relay board, in such a way that the power supply is connected to the smartphone, which is to be charged. Mainly, the arduino board is also programmed to control the relay to keep the power supply connected to the smartphone only for a limited amount of time, which is specified in the code, by the user. This amount of time to supply power to the smartphone can be changed and set by the user, through the code. The arduino is also programmed to execute tasks, once the smartphone has been charged for the specified amount of time, or when it is fully charged. Now, once the smartphone is fully charged, the arduino board, commands the 4-way relay to transfer the excess power being supplied to charge the power-bank. By doing such operations the excess power being supplied is used to charge the power-bank.

The main implementation of this module, is that whenever the arduino board senses that the power-being drawn from the power-socket is less than five volts, it commands the relay board to connect the power-bank and the charger. By doing so, the smartphone will be charged by drawing power from the power-bank. Here, by this procedure, the smartphone can be charged with an uninterrupted power-supply, even when there is no power being supplied through the adapter. The arduino board is also programmed to control the display, by showing the amount of time in minutes and seconds. The display shows the amount of time for which the smartphone and the power-bank have been charged. It is also programmed to show the amount of time for which the smartphone has been charged by drawing power from the power-bank.

The arduino uno board's program code snippet, is as follows,

```

if(volt == 5.0)
{

    digitalWrite(rel1,HIGH);
    digitalWrite(rel2,HIGH);
    lcd.clear();
    lcd.setCursor(0,0);
    lcd.print("CHARGING BANK ");
    lcd.setCursor(0,1);

    lcd.print("FOR "+String(mobile_min)+"MINS"+" "+String(mobile)+"SECS");

    delay(1000);

    delay(4000);

    delay(1000);
    digitalWrite(rel1,LOW);
    digitalWrite(rel2,LOW);
    lcd.clear();
    lcd.setCursor(0,0);
    lcd.print("CHARGING MOBILE ");
    lcd.setCursor(0,1);
    lcd.print("FOR "+String(bank_min)+"MINS"+" "+String(bank)+"SECS");

    delay(7000);
}

```

The above arduino code is programmed using an extended version of C. This extended version is a language that offers provision for developing efficient programs for embedded devices [4].The result of the smartphone being charged by the power-bank will be displayed.



## II. Second Module

The second module consists of the Arduino uno board and the ESP8266 Wi-Fi microchip. Now as the arduino monitors the relay board and the power output voltage, it sends data to the display and the ESP8266 chip. The data sent to the display is explained in the first module. Here, the interaction between the arduino uno and the ESP8266 are explained. The arduino uno is programmed to send serial data to the connected microchip. Now using the properties of the connected ESP8266 chip, this data can be accessed by means of program code. Now, we had programed the micro-chip to transfer the data to the designed webpage.

The code snippet of the Wi-Fi microchip is as follows,

```
WiFiClient client;

void setup()
{
    Serial.begin(9600);
    delay(10);
    Serial.println("Connecting to ");
    Serial.println(ssid);
    pinMode(D4,OUTPUT);
    digitalWrite(D4,HIGH);

    WiFi.begin(ssid, pass);

    while (WiFi.status() != WL_CONNECTED)
    {
        delay(500);
        Serial.print(".");
    }
    Serial.println("");
    Serial.println("WiFi connected");
    digitalWrite(D4,LOW);
}
```

The implemented second module's output is in the form of a table, where the time of each charging method is displayed. The graphical representation of the time is also displayed in the user's website.

S.NO	DATE	TIME	BATTERY LEVEL(MINUTES)	BATTERY LEVEL(TIME)	POWER BANK LEVEL(MINUTES)	POWER BANK LEVEL(TIME)	SMART LEVEL(MINUTES)	SMART LEVEL(TIME)
1	2019-03-28	07:40:08	00	27	00	31	00	22
2	2019-03-28	07:39:54	00	26	00	30	00	22
3	2019-03-28	07:39:41	00	25	00	29	00	22
4	2019-03-28	07:39:28	00	24	00	28	00	22
5	2019-03-28	07:39:26	00	23	00	27	00	21
6	2019-03-28	07:39:23	00	22	00	26	00	20
7	2019-03-28	07:39:21	00	21	00	25	00	19
8	2019-03-28	07:39:18	00	20	00	24	00	18

Fig 8: Time display

## 5. Conclusion

This paper has proposed a system that can automate the charging process of a smartphone and also use the extra-power-supplied in an efficient manner. This system would be capable of transferring the power supply based on monitoring and time-based counter. Mainly it can use the always connected power-bank as an automatic power backup. This smart-charger can be additionally upgraded to observe other electronic

devices. Further improvements to the system can be made in order to increase the hardware performance through advanced components and also by the use of nanotechnology.

## 6. References

1. Mohamed Irfan Sadiq ,Akshatha P,Bharath SP; IoT based smart garbage collection system and alert system,International Journal of Advance Research, Ideas and Innovations in Technology
2. Venkatesh Neelapala , Dr. S. Malarvizhi,Environment Monitoring System Based on Wireless Sensor Networks Using Open Source Hardware,International Journal of Engineering Research and Sports Science,2015
3. [https://www.google.com/search?hl=enIN&authuser=0&rlz=1C1CHBF\\_enIN830IN830&ei=rTCOXMjQLM7e9QPHhpflDw&q=proteus+labcenter&oq=proteus+labce&gs\\_l=psyab.1.0.0l3j0i22i30l7.3904.5870..7779...0.0..0.126.480.5j1.....0....1..gws-wiz.....0i71j0i67j0i10.Otau3kzzOho](https://www.google.com/search?hl=enIN&authuser=0&rlz=1C1CHBF_enIN830IN830&ei=rTCOXMjQLM7e9QPHhpflDw&q=proteus+labcenter&oq=proteus+labce&gs_l=psyab.1.0.0l3j0i22i30l7.3904.5870..7779...0.0..0.126.480.5j1.....0....1..gws-wiz.....0i71j0i67j0i10.Otau3kzzOho)
4. [https://www.google.com/search?hl=enIN&authuser=0&rlz=1C1CHBF\\_enIN830IN830&ei=SDKOXMyoCsS2rQGwo5egAQ&q=embedded+c&oq=embedded&gs\\_l=psy-ab.1.2.0i67l3j0l6j0i131.22933248.22936968..22938522...0.0..1.158.2548.23j7.....0....1..gws-wiz.....0..0i71j33i160.haRbMunlOQo](https://www.google.com/search?hl=enIN&authuser=0&rlz=1C1CHBF_enIN830IN830&ei=SDKOXMyoCsS2rQGwo5egAQ&q=embedded+c&oq=embedded&gs_l=psy-ab.1.2.0i67l3j0l6j0i131.22933248.22936968..22938522...0.0..1.158.2548.23j7.....0....1..gws-wiz.....0..0i71j33i160.haRbMunlOQo)

---

# Comprehensive Assistance for Visually Challenged Persons

Y Sriharsha , K Akshaya , V Shravan kumar , D Ashok

Department of CSE,  
SRM Institute of Science and Technology,  
Chennai, India

---

**ABSTRACT:** *The main objective of the paper is to develop a personal assistant for differently-abled persons who are suffering from partial blindness. The assistant is controlled using voice commands through microphone input , the assistant also helps them to control the device solely based on voice along with hands free typing using speech recognition and optical character recognition from an image for their easier understanding of texts in a book or from a photograph . This paper deals with the different modules which would prove to be helpful for persons who are visually impaired.*

**Keywords:** *Speech Recognition , Personal Assistant , Visually impaired , Hands free access , Hands free typing , Optical character recognition*

---

## 1. Introduction

The life of a partially blind person can be improved by leaps and bounds if they can use any device which helps them connect to the internet for various purposes. Partially blind people who are 30 to 60% blind can access a device with maximum brightness by reducing the distance between their eyes and the screen which sometimes might lead to severe neck pain and eye strain. Speech recognition can be used in a device to help people access the device hands free thus providing a way for partially blind people a different and easier way to interact with the device. Hands free typing is a relatively new technology compared to speech recognition. Hands free typing enables user to type through their voice rather than conventional method of typing through keyboard, this method is faster than typing through keyboard and can help the person tremendously. These technologies been implemented in this model would help the person to access the internet through voice , type through voice and also recognize text from the image which would be further converted into speech for easier understanding .

## II. Related Work

Swati Vikas Kodgire [1] introduced the different approaches for the image to speech conversion processes and also explained about the traditional methods and as well has the current trending and developing methods in the field of optical character recognition. The author also explained about the basic required steps in the process of conversion of image to speech which included pre processing steps like removal of the background , conversion of grayscale then implementation of the recognition of the image using different approaches and software.

Jisha Gopinath [2] presented the steps to be followed to implement text to speech conversion of an image. The author also discussed about the typical components of an optical character recognition system along with the text to speech conversion of a artificial voice synthesis system.

Veton Képuskai [3] discussed about the general architecture of conventional dialogue system with six components and proposed a new virtual personal assistance system with better user interface and inference engine along with an offline and online knowledge base. The author also depicted the model of future virtual personnel assistants with better input , processing and output model.

Giancarlo Iannizzotto [4] implemented a virtual personal assistant which activates based upon either voice commands or facial recognition. The assistant could be customized and is speech enabled. The author implemented a face detection and recognition module with the use of a camera along with few voice commands to use the virtual assistant. The author developed a complete prototype with realistic graphic along with various other required modules.

Wayne Wobcke [5] used BDI architecture module for coordination and dialogue action as well as point to point communication between agents. The author also made domain independent dialogue modules as well as integrated learning system for users reference which are acquired automatically.

Aditi Bhalerao [6] developed an application using voice and its objectives was to handle the incoming and the outgoing calls through voice command along with incoming and outgoing messages through voice

command and to perform some basic operations through voice command using text to speech engine which converts normal language text into speech and action can be in the form of text message or call.

Ekenta Elizabeth Odokuma [7] implemented the system of controlling the device locally using voice commands. The author was able to perform local functions like playing music, opening a file but the author did not implement any online processes like searching online or opening a browser and various other functions.

Peter Imire [8] discussed various ways in which new technologies can be used to create an intelligent Virtual Assistant that focus on user based data. The author also suggested newer technologies would make the idea of personal assistant a reality without the need of human interference in the future.

Aditya K [9] implemented a fully working and functional virtual personal assistant using raspberry pi . The author highlighted the use of a local module for offline purpose which can be added or removed at the user's discretion. The local module can converse with the user and also learn from the conversation for further more interact conversations.

### III. Proposed System

Our system deals with various required functions of a visually challenged person with partial blindness of about 30 to 60 %. They can look at screen and understand the displayed characters or other entities on the screen due to its increased brightness as well as their partial vision impairment.

The proposed model has a tesseract module which has been enhanced with additional filters for better character recognition even with smaller size images and pixelate images. The input image is re-sized and then the brightness of the image is increased. Then median filtering technique which removes noise as well as it does so while preserving the edges of the image.

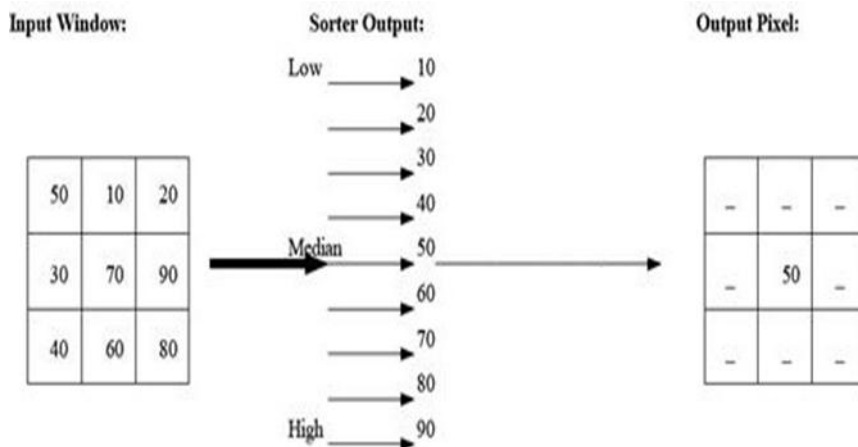

Fig 1 Median Filtering

Once the median filtering is complete the image is passed into tesseract for optical character recognition and the obtained text from recognition is sent through Google API for voice output of the image recognition.

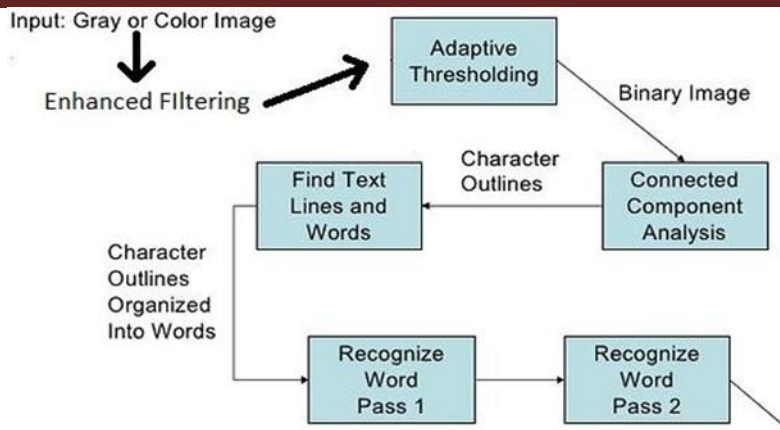

Fig 2 Enhanced Tesseract

In figure 2 the image is enhanced through filtering methods and then the image is sent to the conventional tesseract for optical character processing to obtain the text from the image.

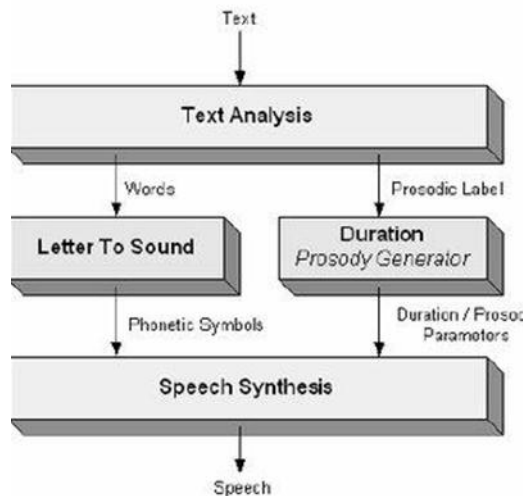

Fig 3 Text to Speech Architecture

The model also has a Text to Speech API provided by Google which converts the input voice commands into text and also converts the obtained text from optical character recognition through tesseract to speech. In figure 3 the input text is sent to the text analyzed and the text is split into words and phonetic symbols are attached to the words. This combined with duration obtained from the Prosody Generator helps in modifying the input text into speech. The proposed model also has a custom designed talk typing model.

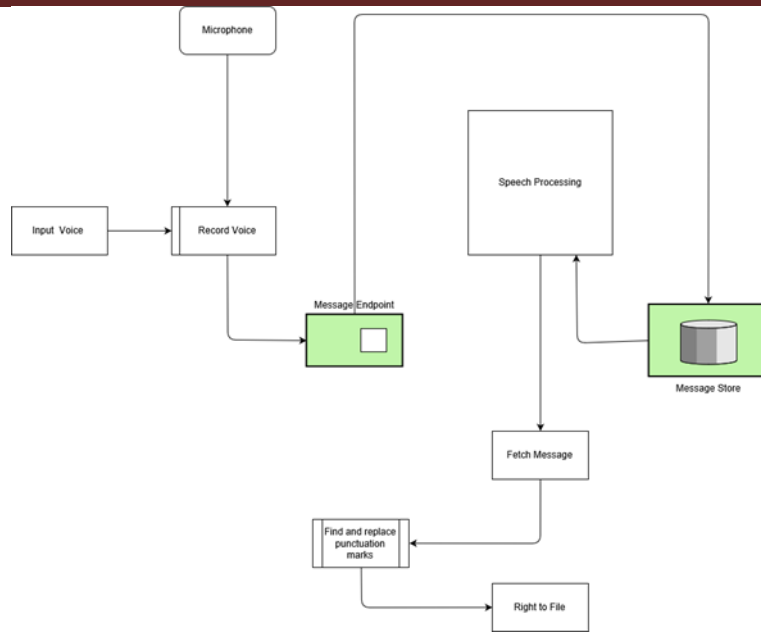

Figure 4 Talk Type Module

The generic talk typing modules available online do not support a majority of available browsers and is limited to Google chrome. This custom build module ( Figure 4 ) uses the microphone to record input voice for a duration of time. Once the duration expires and the message reaches its endpoint the message is stored. The stored message is used in the speech processing using Google Text to Speech API and the processed text is returned as a message. The returned message is captured and is written to a file for further editing work or for other purposes. This custom build module is able to incorporate special character also into the word document unlike native talk typing models available online. The proposed model contains various other functions which are used to control the device, open web pages and also navigate the web pages, and various other necessary functions.

**IV. Results**

The enhanced filters passing of an image before performing optical character recognition through tesseract improved the character recognition of the smaller images with no continuous boundaries of the edges and the enhancement also improved the character recognition of small and pixelated images compared to the conventional tesseract which does not apply any additional filters before processing the image for character recognition.



Input Image for Tesseract

```
In [2]: runfile('...', wdir='...')
cannot process the image
```

Output from Default Tesseract Code

```
In [5]: runfile('...', wdir='...')
The recognized text is :
Gm
```

Output from Tesseract after enhanced filtering

The talk typing module achieved efficient transformation of speech to text with an average of 80 to 100 words per minute .The module is able to find and replace necessary punctuation in the speech with the exact punctuation marks instead of the preceding command to insert a punctuation .

### V. Future Enhancements

The further enhancements or future work can be done in the following directions : Migrating this project into a mobile level application for either Android or Windows for easier access on ones personal device, Addition of newer and more modules like an interface for chatting with the user or emergency modules to contact the authorities or closer relatives through GSM ( Global System for Mobile Communication ) modules in case of any unforeseen events.

### VI. Acknowledgement

This project was guided by Mr D Ashok , SRM INSTITUTE OF SCIENCE AND TECHNOLOGY.

### References

1. Swati Vikas Kodgire<sup>1</sup>, G. S. Sable<sup>2</sup> ,A Review on Optical Character Recognition and Text to Speech Conversion
2. Jisha Gopinath<sup>1</sup>, Aravind S<sup>2</sup>, PoojaChandran<sup>3</sup>, Saranya<sup>4</sup>, 2015 ,Text To Speech Conversion System Using OCR , International Journal of Emerging Technology and Advanced Engineering ( IJETAE)
3. Veton Kėpuska<sup>1</sup>, Gamal Bohouta<sup>2</sup>, 2018 , Next-Generation of Virtual Personal Assistants (Microsoft Cortana, Apple Siri, Amazon Alexa and Google Home) , IEEE
4. Giancarlo Iannizzotto<sup>1</sup>, Lucia Lo Bello<sup>2</sup>, Andrea Nucita<sup>3</sup>, Giorgio Mario Grasso<sup>4</sup>, 2018 , A vision and speech enabled, customizable, virtual assistant for smart environments , IEEE
5. Wayne Wobcke <sup>1</sup> , Anh Nguyen<sup>2</sup> , Van Ho<sup>3</sup> , Alfred Krzywicki<sup>4</sup> , 2007 , The smart personal assistant : An overview, American Association for Artificial Intelligence (AAAI)
6. Aditi Bhalerao<sup>1</sup> , Samira Bhilare<sup>2</sup> , Anagha Bondade<sup>3</sup> , Monal Shingade<sup>4</sup> , Aradhana Deshmukh<sup>5</sup> , 2017 , Smart Voice Assistant : a universal voice control solution for non-visual access to the android operating system , International Research Journal of Engineering and Technology (IRJET)
7. Ekenta Elizabeth Odokuma<sup>1</sup> , Orluchukwu Great Ndidi<sup>2</sup> , 2016 , Development of a voice-controlled personal assistant for the elderly and disabled , International Research Journal of Computer Science (IRJCS)
8. Peter Imire<sup>1</sup> , Peter Bednar<sup>2</sup> , 2013 , Virtual Personal Assistant , Proceeding of 10th Conference of the Italian Chapter of AIS.
9. Aditya K<sup>1</sup> , Biswadeep G<sup>2</sup> , Kedar S<sup>3</sup> , S Sundar<sup>4</sup> , 2017 , Virtual Personal Assistance , School of Electronics Engineering.



## Data Framework for Small-Scale Provincial Farmers

D Elanthazhai, S Vishnupriya, Prince Niroshan, T Malathi

Department of CSE,

<sup>1</sup>SRM Institute of Science and Technology,  
Chennai, India

---

**ABSTRACT:** *We propose a system to intimate farmers about the crops to be seeded in the specific season and also make the farmers aware of the current market rate of the product. This type of system is much beneficial for the young generation to adapt to the traditional farming technique. In this machine learning is used for fetching the location from the users. Experts will save the location based details in the database and they will update when they get any new information about the location. Admin will manage the details about the user and expert detail and update it in the query timing. This application is useful for the young generation farmers when they doubt while they yielding the crops in their land.*

**Keywords:** *farmers, web application, k-means clustering algorithm, machine learning*

---

### 1. Introduction

There are no more than handful of working applications which provide farmers with various needed information and other necessary details. The proposed web application serves the purpose of a complete guide for the farmers to depend on for the various details of farming from planting the right crops based upon the soil acidity and water retentive content to the optimal seeds for the location based on the time period and weather information. This application also serves as a portal for farmers to obtain the right price for the farmers yield from the agent and also lets the farmer bargain for the optimal price range with the agent for their yield thus reducing the amount of travel for the farmers to and fro from the agents and also helps them obtain the best price for their crop.

### II. Literature of Surevy

G.Naveen Balaji [1].As the new technology as been introduced they want to implement the advancement in the field of agriculture so they have introduced the smart crop monitoring system using IOT. With the help of this system they can keep track on the land and maintain the soil moisture, humidity and temperature of the area. All this modules will be collected by using the sensors like temperature, humidity and soil moisture sensor.

Deepak Murugan [2].In this paper they have discussed about for better food production and management they have introduced a precision agricultural monitoring system for large scale farmers using satellite data and drone data. They also want to minimize the drone used in this system and also an approach to segregate the sparse and dense area within the selected area and implement the system.

Nikesh Gondchawar [3].In this paper they are mainly concentrating on the issues which is hindering the development of the country. The main aim of this project is to make the agriculture smart based on Iot. By using remote control robots they are performing operation like spraying, weeding etc and they are performing smart irrigation and warehouse management.

Sushant Wavhal [4].In this paper they have introduced an application in which it contains all the aided government schemes that are available. The main motive for this application is that the farmers are not aware of the schemes available so that they can get the benefits. The information will be passed to the farmers in the form of message.

Nived Chebrolu [5].The only way for preventing the agriculture is continuous monitoring. In this paper they have introduced a method for saving the image which is taken by the unmanned aerial vehicles(UAV) that shows large variation in the visual appearance over the crop season. This method utilizes the inherent geometry of the crop arrangement by exploiting the negative information about missing crops .By using this images they can compare and identify the problem. This method provides a robust and efficient alignment which in turn allow us to obtain temporally aligned 3D point cloud and to monitor individual plant.

Anand Nayyar [6].In this paper they have developed smart farming to make the agriculture production cost effective and to reduce their wastage .The important feature of smart farming is they will be developing a agricultural stick which will be inbuilt with arduino technology .This stick when placed in the field it will

keep on updating the soil moisture, temperature etc. So that the farmers can use the information to increase their yield and to increase the quality of their product.

Apostolos rousalis [7] created a system which manages and monitors the crops of the farmer using various different services which use the cloud computing serves to the maximum extent in accordance with internet of things . The author also planned to implement a scheduling system with alerts to the farmers through mobile application.

### **III. Proposed System**

We propose a system to intimate farmers about the crops to be seeded in the specific season and also make the farmers aware of the current market rate of the product. . This type of system is much beneficial for the young generation to adapt to the traditional farming technique. Bidding is a tedious task but our proposed system gives the actual market rate and then it clarifies the user about the current market rate to avoid the farmer bidding or getting cheated by the retailers . In this system we will be using k-means clustering algorithm for the location based search. By using the algorithm it will automatically locate the area and it will give suggestion to the farmers like what all crops can be planted in that season.

#### **3.1 Modules**

##### **3.1.1 Administrator Endorsement**

The farmers will register in the website with their own details like username, password, contact details, address details. The admin will verify the details and approved. Then only farmers can sign in and ask for a query with expert. The farmers can also query about the fertilizer and also much related information about the agriculture.

##### **3.1.2 Monitor and Maintain the Crops**

Farmers will get the response from the expert for the query which they have sent based on the response they can clarify their doubt and help to improve their crop yield. Experts will keep on predict the temperature, soil moisture and the crops which can be planted on that particular season and they will update the information in the website. This will be very helpful for the young farmers to overcome from their doubt about the farming lands so that they can improve their yields.

##### **3.1.3 Predict and Detect Pests**

The farmers sometimes unaware of expert price about the crop they sell in the market. The small farmers often sell their product to local traders, this could be an important bargaining tool. Also, farmers can decide on whether to take product to the market or delay it based on the information on current price advised by the expert.

##### **3.1.4 Online Computerized Agri-Auction Portal**

Make farmers get the best price for their products. Farmers get to know the demand in the market of the products they are selling. This will help them to concentrate on the crops which is in high demand. The online bidding application helps the farmers meet the customers directly. Farmers can choose their customers who quote more , that is they can choose whom to sell their products on the basis of the price the customers are ready to pay.

##### **3.1.5 Fertilizer Expert System**

In this system the expert will give suggestions to the farmers about what kind of fertilizers and the quantity of fertilizers should be used for their crop based on the query they have received from the farmers. They will also be keep on updating in the website with different types of fertilizers which can be used for the crops. So that it will be useful for the upcoming farmers and they will not face any difficulties.

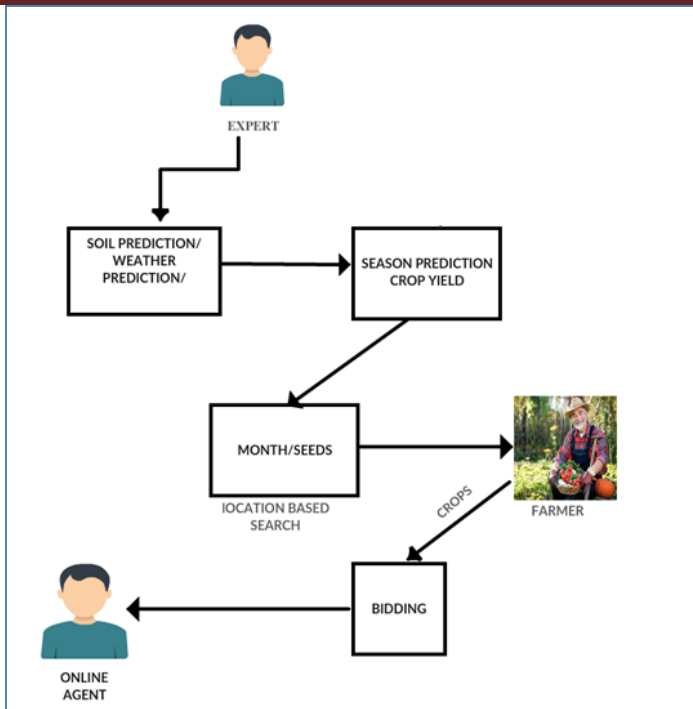

Figure 1 Farmer architecture diagram

The System starts with pre calculated values based upon the user’s location using soil quality and the weather of the particular region. Using the above calculated values the prediction of the best crop for the a particular season on the users location determined and the data is made available for the farmers to be used through the online portal . This system information the farmers about the best crop for their agricultural field based on the weather information . This web application also has a portal for agent bidding which reduces the hazel of the farmers to sell the crop for the best price.

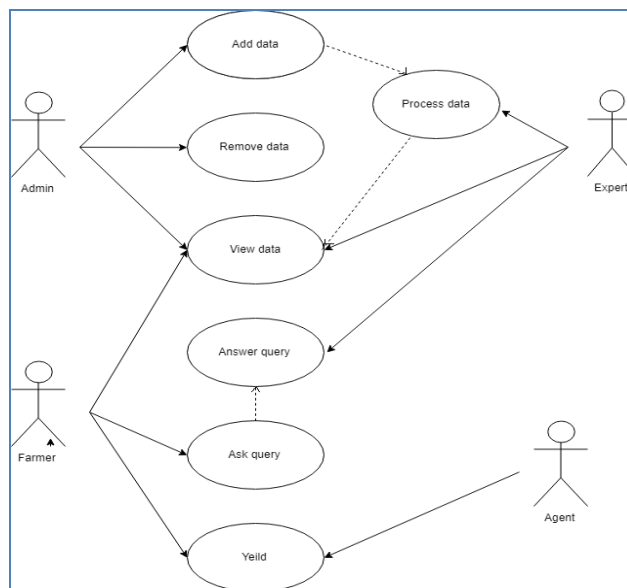
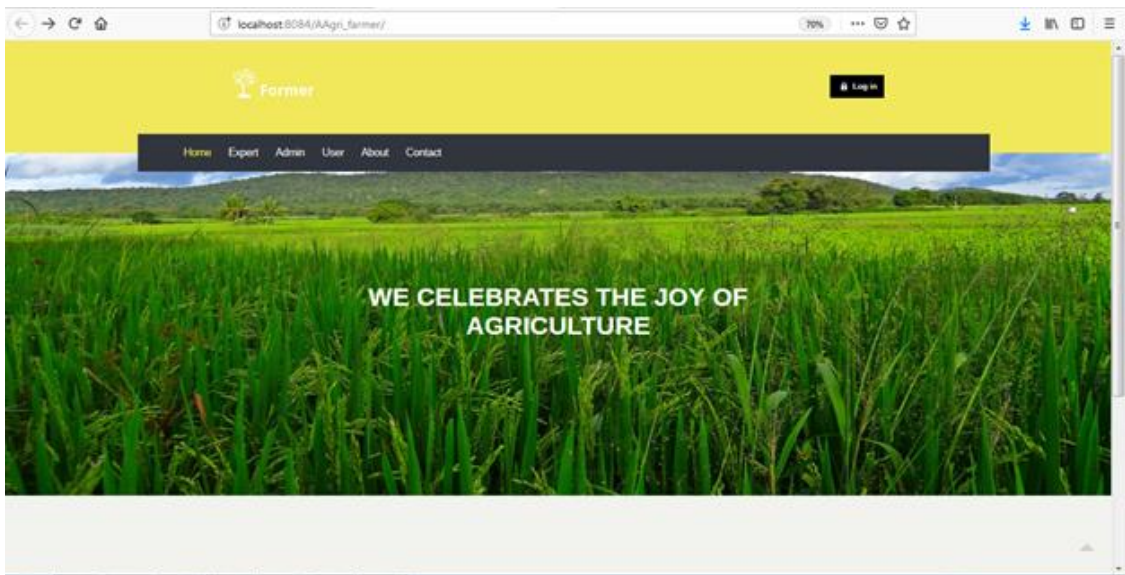

Figure 2 Use case Diagram

The project consists of four actors Agent , Farmer, Expert, Admin. The purpose of the admin is to add different types of data alike soil acidity , soil water retention level and other weather related data and also has the ability to remove the data. The expert uses the data added by the admin and uses various machine learning models to obtain the apt model for the different data and derives the best crops to plant and the expected yield. The farmer as access to the data given out by the expert after processing and also as the right to ask the expert different queries where the expert answers the queries . The farmer can bid online about the rate of the yield with the agent through online to reach the optimal selling price of the obtained yield by the farmer.

#### IV. Result and Output



4.1 Home Page

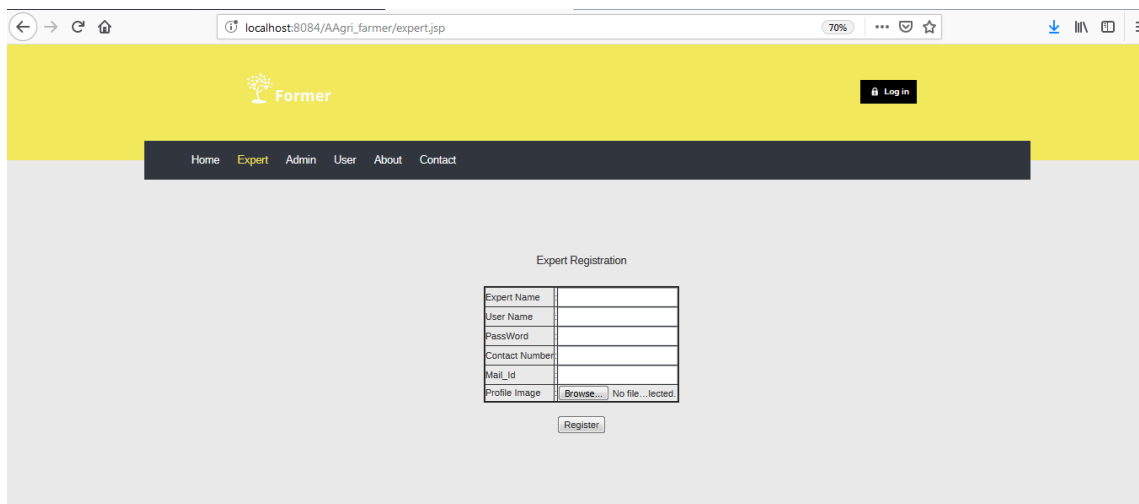

4.2 Expert Registration Page

#### V. Conclusion

This Application deals with and also tries to remove or eradicate the difficulties faced by farmers from the selection of seeds for the particular piece of land based upon the weather and other important factors and also acts as a medium for the farmers to obtain the right price for their crop yield from the agent by directly coupling the farmer with he agent through the portal.

## VI. Acknowledgement

The project was guided by Ms.T.Malathi , SRM INSTITUTE OF SCIENCE AND TECHNOLOGY.

## References

1. Nived Chebrolu<sup>1</sup>, Thomas Labe<sup>2</sup>,Cyrill Stachniss, 2018 , Robust Long-Term Registration of UAV Images Of Crop Fields for Precision Agriculture, IEEE
2. Anand Nayyar<sup>1</sup>,Er.Vikram Puri<sup>2</sup>,,2016 , Smart Farming: IOT Based Sensors Agricultural Stick for Live Temperature And Moisture Monitoring using Arduino, Cloud Computing And Solar Technology, Conference
3. Joan R.Rosell-polo<sup>1</sup>,Eduard Gregorio<sup>2</sup>,Jordi Gene<sup>3</sup>,Jordi Llorens<sup>4</sup>,Xavier Torrent<sup>5</sup>,Jaume Arno<sup>6</sup>,Alexender Escola<sup>7</sup>,2017,Kinect V2 sensor-Based Mobile Terrestrial Laser Scanner for Agriculture outdoor Applications ,IEEE
4. Sushant Wavhal<sup>1</sup>,Nishtha Tiloo<sup>2</sup>,Ruturaj Haral<sup>3</sup>,Pragati Tekawade<sup>4</sup>,2017,Farmer Friendly Application for Resource Mapping of Village with Government Aided Schemes, IJESC
5. G.Naveen Balaji<sup>1</sup>,V.Nandhini<sup>2</sup>,S.mithra<sup>3</sup>,N.priya<sup>4</sup>,R.Naveen<sup>5</sup>,2018,Iot Based crop Monitoring in Farm Land, IJIR
6. Nikesh Gondchawar<sup>1</sup>,R.S.Kwitkar<sup>2</sup>,2016,IOT Based Smart Agriculture, IJARCCCE
7. Deepak Murugan<sup>1</sup>,Akanksha Garg<sup>2</sup>,Dharmendhra Singh<sup>3</sup>,2017,Development Of An Adaptive Approach For Precision Agriculture Monitoring With Drone Satellite Data, IEEE
8. Apostolos Rousalis, Stelios Sotiriadis<sup>2</sup>, Euripidies G.M.Petrakis<sup>3</sup>,2018,Management Of Farms And Crops Data On The Cloud, IEEE

---

# Emotion Detection Using Video Frames

<sup>1</sup>S Sanarker, <sup>2</sup>Raj Shekhar, <sup>3</sup>Mrs Lakshmi

<sup>1,2</sup>Student, Department of CSE, SRMIST, SRM Vadapalani, Chennai, India

<sup>3</sup>Asst. Proffesor, Department of CSE, SRMIST, SRM Vadapalani, Chennai, India

---

**ABSTRACT:** An Emotion detection mechanism using facial features is presented in this paper. The overall mechanism is composed of mainly two modules: Face detection module and emotion detection module where the emotion will be identified. In the Initial part of the mechanism, i.e. the face detection module, face is detected in the input, then the input is converted to a gray-scale image, this gray-scale image will be fed into the emotion detection module. For emotion detection module, CNN Model will be used, where the features required for a particular emotion from the face will be identified. These features will be then processed and in the end, based on features the identified, emotion will be detected and predicted from the video.

**Keywords:** Emotion detection, facial features, CNN model, feature extraction, face detection

---

## 1. Introduction

Emotion Detection of humans can be achieved by various body factors like voice, text, body style, human behavior and facial image. The technology is still an ongoing problem that has certain limitations but as technology improves problems like this will become easier to solve and achieve more accuracy and functions, detecting emotions can play a major role in identifying and executing sentimental analysis for several types of industries. Emotion detection can be achieved using several components which includes speech, text, body motion detection, facial image and many more. For this paper we have decided to use facial image to identify and predict emotions. Front facial is the most common way to detect emotion, the whole procedure involves detecting and extracting facial features and then using the data to identify the emotion of a human being. There are 4 basic human emotions, they are happy, sad, fear/surprise and disgust/anger [7]. which are then later refined into six categories namely happy, sad, fear, surprise, anger and disgust.

In this paper, we have divided the whole process into two modules: face detection module and emotion detection module. In face detection module, we are capturing and identifying the face based on facial features. Once the face features have been defined and identified, the input is fed into the emotion detection module to extract and identify the type of emotion observed, then the type of emotion is predicted.

## II. Existing System

### A. Architecture

In the existing system, an algorithm is proposed for emotion detection. This algorithm has been classified into various stages as depicted in the architecture in Fig 1., Face region extraction and facial component extraction make up the image processing stage of the system, the feature extraction stage where the features that are prominent in the image like eyes are extracted and the final stage emotion detection via fuzzy classifier where emotions are classified according the features observed and extracted. In the initial image processing stage, face detection occurs, this is done using Virtual Face model in Fig 2 and the histogram analysis method, several information are extracted from the face including geometric and shape information, Fuzzy classifier is used in emotion detection stage, so when the features are provided, the classifier returns the emotion that is detected.

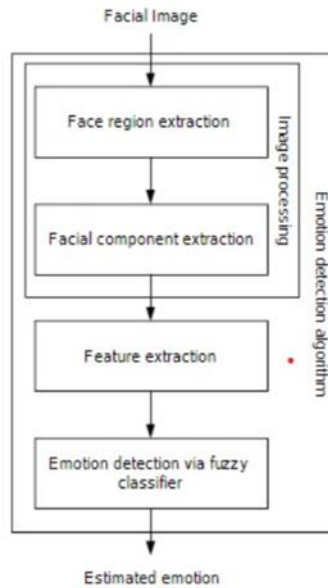

Figure 1 Existing Emotion detection Architecture

### B. Implementation

Emotion detection procedure can be described as following steps:

Step 1: In the first step, fuzzy colour filter is applied, and facial feature is extracted by using histogram analysis. The grey image formed, is further converted into histogram vector  $O$  and  $P$ .

Step 2: In the second step, once the colour filter is applied, all important face components are extracted using the method of VFM based histogram analysis. VFM is used to reduce the searching space for histogram method.

Step 3: Third step comprises of extracting feature vector from the facial component. This is the most important point in solving the emotion detection problem. This method divides the whole face into three important region i.e. the eye, mouth and eyes. Several features are extracted and information like geometric and shape is occupied

Step 4: Identify fuzzy classier with the extracted feature vector. Fuzzy classifier sets are created and compared to identify the features of the face.

Step 5: Test fuzzy classier. Once Fuzzy sets are created they are tested to identify the emotions that are observed

### C. Drawbacks

The first two steps of the procedure were able to identify and correctly extract facial features of 124 facial images, the procedure failed to extract facial components from 36 other images which contain facial features. In the emotion detection stage out of 124 images of which facial feature vectors were identified 13 images were not able to be classified into any of the emotion class. This indicates the fuzzy classifier and the fuzzy colour filter used in face detection do not perform well. This results in low accuracy because of the small sample size of the data and the limitations of the fuzzy classifier.



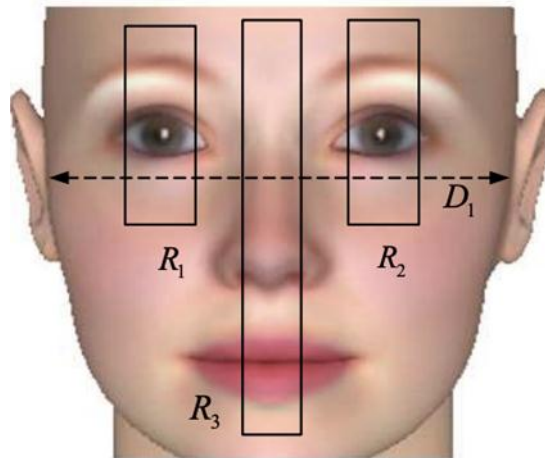

Figure 2 Virtual Face Model

### III. Proposed System

#### A. Introduction

The proposed system uses OpenCV to pre-process the input image to be fed in to the input layer of the cnn. The cnn used here uses depth-wise separable convolutions instead of normal convolutions. Then the convolutional neural network is used to process the input image data and make a prediction. The cnn will extract prominent features from image like eyes, mouth, nose etc. and uses these features to identify emotions. The cnn model used in this architecture is based on the tiny-ception model. Finally, the output layer makes a prediction on the data that is passed on from the cnn layers and using soft-max function will identify the type of emotion that is observed.

#### B. Architecture

1) Input Layer: The proposed system uses a CNN architecture. The first layer is the input layer through which the input image frame will be fed through. OpenCV is used to detect the faces present in the image frame. This image must be preprocessed with pre-determined fixed dimensions before it is fed in to the layer. The haar-cascade-front face- default.xml in OpenCV already contains filters that are pre-trained to find the facial layer and crop it. The cropped part of the face is then converted into grayscale using cv2.cvtColor method and resized to 48x48 pixels with the cv2.resize method.

2) Convolutional Layers: The convolution used in this architecture is based on the tiny-ception cnn model [10], this particular architecture combines the usefulness of residual modules [10] and depth-wise separable convolutions [10]. The residual modules modify the mapping that is desired in-between two successive layers, so that the features that are learned become the difference of the original feature map and the desired features, as a result the desired features are modified in order to solve an easier learning problem. By using the tiny-ception model, fully connected layers are entirely eliminated from the neural network, this is because of the ability of the depth-wise separable convolutional layers. The main initiative of these layers is to separate the channel cross-correlation from the spatial cross-correlation.

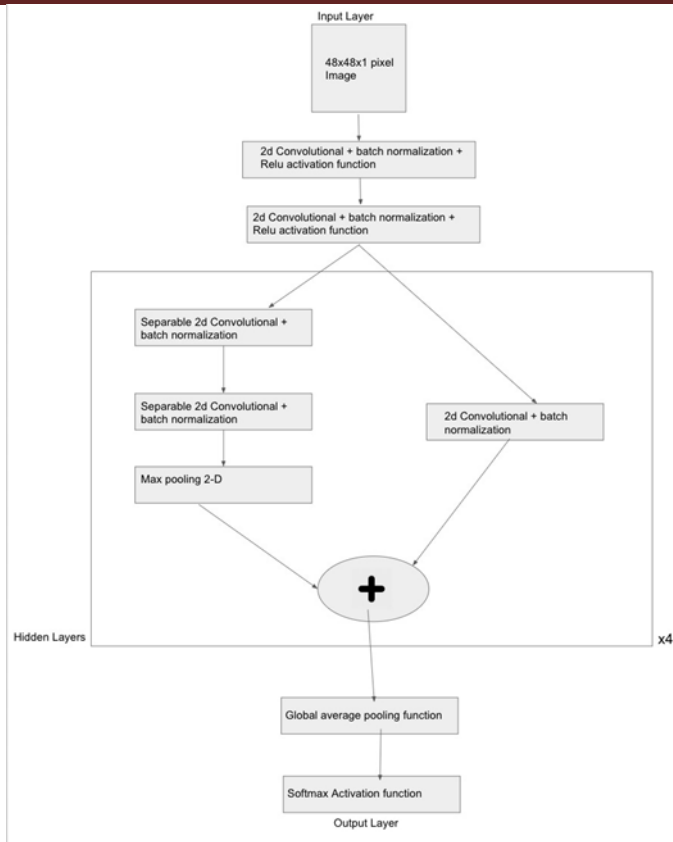

Figure 3 Tiny xception CNN Architecture

The data-set used to train the model is the FER2013 data-set. It contains 48x48x1 pixel images of faces. The emotion classes represented in the data-set include angry, happy, sad, surprise and neutral [].

The tiny-xception model is a fully-convolutional neural network with no fully connected layers. The final layer consists of a global average pooling and a soft max activation function to produce a prediction.

3) Output Layer: In the final layer of the convolutional neural network a global average pooling method and a soft max activation function is applied to make a prediction. It predicts what type of emotion is observed and by using the soft-max function the probability of the emotion observed is also calculated between the range of 0 to 1.

**C. Implementation and Result**

1) Face Detection Module-OpenCV: OpenCV is an open source computer vision library. OpenCV uses Haar-Cascade classifier which is pre-trained classifier that is used for face detection. The classifiers are stored in the form of xml files and the xml file classifier used for face detection is haarcascade-frontface-default.xml. The library numpy is also used which is useful for numerical operations and numpy arrays.

Using the video capture method, the video is taken as input. Then the RGB image from the video capture method is converted in to grayscale effectively reducing the channel size from three to one. Then using the imshow method the window is displayed where output is shown whether face is detected or not.

2) Emotion Detection Module-CNN: The first layer is the input layer of the cnn, a 48x48x1 pixel image is fed into this layer. Before the depth-wise separable convolutional 2-D is used, normal 2-D convolution is performed to form the base module of the network. The residual layer is then added on to the depth-wise separable convolution layer, starting from the residual layer to the ReLU activation functional constitutes as one layer called as residual depth-wise separable convolutional layer. There are four such layers in the model as indicated in figure. All such layers are hidden layers.

The output of one layer is added up on the output of the next layer, it also passes the output of one layer to another. This is in relation to the equation  $y = f(x) + x$ . As the CNN progresses through the layers, the second hidden layer in the residual depth-wise separable convolution the number of kernels is increased because

the second hidden layer feeds from the first hidden layer, this is done to properly measure the richer projection of input from hidden layer 1, as such in each subsequent hidden layer the number of kernels increases. In the initial hidden layer the kernel size is 8 it increases to 16, 32 and 64 in the subsequent hidden layers because of the richness of the output of the layers. This in turn avoids the bottle-neck effect.

The function used to form the depth-wise separable convolution layer is the SeparableConv2d function. It takes filters, kernel-size, strides, padding, kernel-regularization and use-bias as parameters which is then followed by batch normalization activation function and ReLU activation function. Then the max-pooling2D algorithm is used after the activation function ReLU. Then the residual layer is added on to the depth-wise separable convolutional layer, for all the residual depth-wise convolutional layers.

After the final hidden layer, the outputs of the hidden layers are put through the GlobalAveragePooling method, this is because of the final max-pooling2D in the hidden layer contains one activation map for each emotion present in the dataset. Then the max-pooling2D layer is fed in to the GlobalAveragePooling layer which yields a vector for each possible emotion. This is then fed into the soft-max activation function which produces a predication on what emotion is being observed and the probability of the emotions between the values 0 to 1.

3) Result: Results of the emotion detection classification task in real time has been demonstrated in Fig 5 . Normalized Confusion Matrix is provided in Fig 4, where the results of our classification task can be found where it shows the tiny- xception cnn model predicted label against true label. As observed from the results fear is our worst emotion label that is predicted from the model and happy is best emotion label detected in the model.



Figure 4 Different Emotion Labels

#### IV. Conclusion and Future Work

In this paper we have presented a model emotion detection using depth-wise separable convolutions and residual networks. Machine learning models influenced by the data that they trained on. The architectures used have been systematically used in order to reduce the amount of parameters, first by eliminating fully connected layers and by reducing the number of parameters in the remaining convolutional layers with the depth-wise separable convolutions. It is shown that the proposed model can be stacked for multi class classification while in real-time. As observed from the confusion matrix in fig. Happy is the emotion class where the network fares the best whereas fear is the class where the network performs the worst. This is because of the class distribution of the training data-set. Several other common misconceptions are also made like labelling and predicting sad instead of fear and predicting angry instead of surprise. This happens due to the label angry that is highly activated when detects a person is heavily frowning. As observed the

lighting conditions where the architecture is used must be bright enough to distinguish a face and facial features.

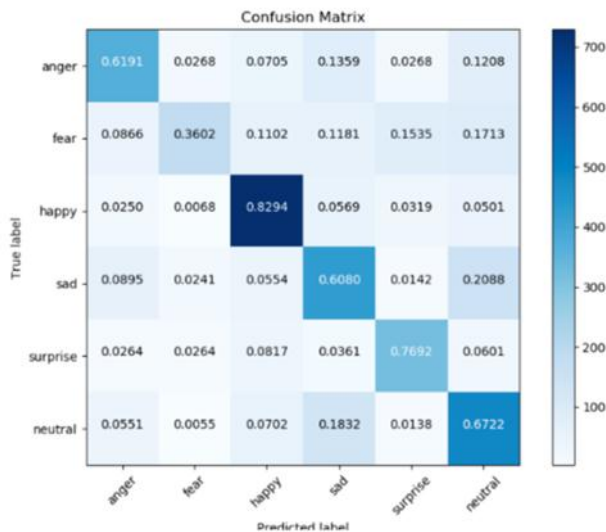

Figure 5 Normalized Confusion Matrix of Emotions

### References

1. Kim Joo, Young Hoon Bae Park, Jin. . Emotion Detection Algorithm Using Frontal Face Image.
2. D. Dagar, A. Hudait, H. K. Tripathy and M. N. Das, "Automatic emotion detection model from facial expression," 2016 International Conference on Advanced Communication Control and Computing Technologies (ICACCCT), Ramanathapuram, 2016, pp. 77-85. doi: 10.1109/ICACCCT.2016.7831605
3. Tarnowski, Pawe Koodziej, Marcin Majkowski, Andrzej Rak, Remigiusz. (2017). Emotion recognition using facial expressions. *Procedia Computer Science*. 108. 1175-1184. 10.1016/j.procs.2017.05.025.
4. Jyoti Kumari,R. Rajesh,K.M. Pooja, Facial Expression Recognition: A Survey(2015), *Procedia Computer Science*
5. Arriaga, O., Valdenegro-Toro, M., Płger, P. (2017). Real-time Con- volutional Neural Networks for Emotion and Gender Classification. *CoRR*, abs/1710.07557.
6. Chollet, F. (2016). Xception: Deep Learning with Depthwise Sep- arable Convolutions. *arXiv.org*. Retrieved 20 March 2019, from <https://arxiv.org/abs/1610.02357>
7. Jack, R., Garrod, O., Schyns, P. (2014). Dynamic Facial Expressions of Emotion Transmit an Evolving Hierarchy of Signals over Time. *Current Biology*, 24(2), 187-192. doi:10.1016/j.cub.2013.11.064
8. S. Albawi, T. A. Mohammed and S. Al-Zawi, "Understanding of a convolutional neural network," 2017 International Conference on Engineering and Technology (ICET), Antalya, 2017, pp. 1-6. doi: 10.1109/ICEngTechnol.2017.8308186

---

# IOT Based Intelligent Stroke Prediction and Monitoring System

V. Akila (A.P), Navin MV, Mani Arasu D, Yogesh S

Department of Computer Science and Engineering,  
SRM Institute of Science and Technology  
Chennai, India

---

**ABSTRACT:** *This project is a novel approach based on smart prediction and monitoring system of wake-up stroke for senior citizens. Our proposal is a combination of predicting based system, an intelligent alert system and a live health monitoring system. The system works simultaneously by collecting data from multiple sensors connected to a patient and processes for further analysis. This process includes data acquisition, data analytics and live tracking of sensor data in PL/SQL. It generates a three-level alert-based system which includes voice-based alerts, alerting through webpage and a mobile based Android application. The priority is to make sure that the patient receives utmost medical assistance as soon as possible so that the chances of getting deceased by a stroke are scrutinized and diagnosed. This proposed system is designed and developed as an attempt to increase the possibilities of saving a person's life through immediate and momentary diagnosis by the doctor and care-taker in order to prevent from any misleading results.*

**Keywords:** *Sensors, Internet of things, Android application, Alert system, Stroke prediction, Arduino*

---

## 1. Introduction

The Internet of Things (IoT) is considered to be a significant and remarkable field of study in recent times. Nowadays, most of the smart technologies around us are based on IoT either by direct or indirect means. IoT has become a part of our everyday life just like our other basic needs including the internet. IoT has an enormous range of applications in various fields including education, health, military and transport etc. This proposed system is based on an application of IoT in the field of medical research. Stroke is a major health problem that leads to serious, long-term disability worldwide. Falls are common in persons with stroke due to altered gait patterns [1]. Gait alterations include, but are not limited to: decreased walking speed, reduced foot clearance, and spatiotemporal gait asymmetry [1]. A person experiences a stroke by an abrupt disturbance in the flow of blood to the brain. As a result, the blood flow to blood vessels is disrupted and creates an imbalance in the surrounding area. The stroke population, as well as world population, is aging [2]. Stroke is the second leading cause of death above the age of 60 years [3]. Stroke is the third most common cause of death in developed countries [4]. Thus, the use of IoT in the field of medicine using this proposed stroke prediction system has the ability to give the accuracy of a wake-up stroke. There have been various works carried out in the field of SPS. A patient is monitored using the system where the devices used are Arduino Mega, Temperature sensor, EEG sensor, Pulse sensor, Blood Pressure sensor, Bluetooth and a Wi-Fi module. It consists of wearable sensors attached to a patient. These sensors collect real-time data updates and apprise them to our webpage and the mobile application through the NodeMCU. With the help of cloud computing, the data is virtually accessed by doctor or care-taker of the patient.

Engineering solutions have been explored to prevent falls or reduce fall-related injuries in different populations. [5] These solutions can be classified based on the timing of when the engineering system is in action. [5]. Recent advances in brain imaging used to decide whether wake-up stroke started within 4.5 hours window [6]. The current standard technologies for stroke diagnosis are ultrasound, magnetic resonance imaging, and computer tomography. [6]. The system focuses on the victim's pulse, blood pressure, temperature and Electroencephalogram (EEG) values. These values are received and connected to the APR voice module, which is used as a primary level alert. As the priority is to make sure the victim gets medical assistance as soon as possible, the system generates a secondary level alert using a live data streaming webpage which is designed using PHP scripting. If the victim shows any signs of a stroke happening, it is detected using the sensors connected. This in turn, sends alerts to the webpage through the NodeMCU via cloud computing. The system also has an Android based mobile application through which the doctors and the emergency department stay connected with the patient's live and continuous tracking of his/her status of health. This Android application is developed on Android Studio platform and the data is transmitted to the mobile device using a Bluetooth HC-05 sensor.

**II. Component Description**

**A. LM-35 Sensor (Temperature)**

We are using the LM-35 sensor as the temperature sensor. This IC can be helped to measure temperature of a patient body. It is connected using a wearable device and is integrated to the Arduino mega micro controller. This LM-35 integrated circuit shows better accuracy in measuring temperature than a thermistor. It is efficient than thermo couples as its output in volts is directly proportional to the temperature if it measures in i.e., in °C.

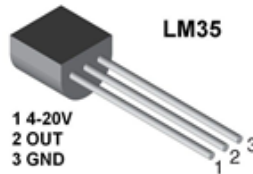

Fig: 1 Illustration of LM-35 Sensor

**B. Pulse sensor**

Another parameter of the patient that is constantly measured is blood pressure. Blood pressure rate can directly affect the patient and immediately succumbs to stroke. It is the amount of pressure of blood pumping through the arteries. This is related directly to the contraction of heart, to flow blood throughout the body. The blood pressure rate includes two parameter, systolic pressure and diastolic pressure. Blood pressure is measured by a blood pressure sensor. This sensor includes a wearable device which is wrapped around the patient’s arms. This data is continuously updated on the microcontroller for predicting a stroke.

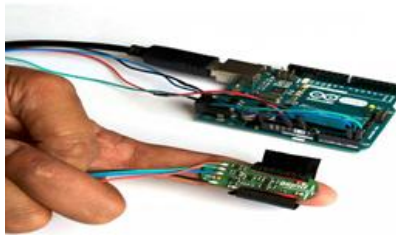

Fig : 2 IR Pulse rate Sensor

**C. Brain Sensor**

A patient’s brain vitals are another important factor in predicting stroke. The brain’s vital are monitored by using Electroencephalogram or EEG. We can collect a patient’s brain waveforms using an EEG sensor. Abnormal conditions in brain wave forms may lead to migraines, tumors, stroke or even an epilepsy or edemas. Our brain cells emit some limited electrical pulses which is collected by the EEG sensor as wave forms. It then amplifies and transmits to the microcontroller for processing the data, measuring the EEG values of a patient.



Fig: 3 EEG Sensor



#### D. Blood Pressure Sensor

Pulse note is another important factor in predicting a woke-up stroke. A victim experiencing a stroke shows either a sudden drop or a surge in his pulse rate. To measure the real-time pulse rate of the patient, we are using a sensor integrating an LED (Light Emitting Diode) and a photo-resistor. It is a high intensity type sensor. The patient skin is exposed to the sensor, i.e., the patient's finger is placed in between the LED and photo-resistor. A visible light ray (red) is passed through the skin and is reflected by minute fluctuations in the tissue because of the blood flow through the arteries. The sensor pre-processes the signal and with a combined processing of analogue and digital data the pulse rate is measured effectively.

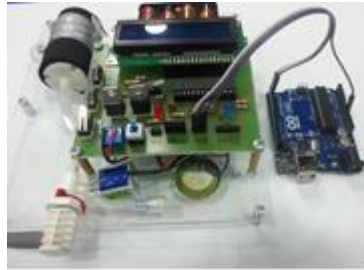

Fig: 4 Blood Pressure Sensor

#### E. NodeMCU

The NodeMCU is a microcontroller which acts as a host for the Arduino mega to any web-page that is linked to it. The NodeMCU integrated circuit which is used in this device is named as ESP8266. This provides a solution to other modules as it is capable of hosting a self-contained webpage or web-application. One can flash the module to a server or local host at ease.



Fig: 5 NodeMCU (ESP8266)

The ESP8266 has a core-processor which is integrated with a 32-bit MCU micro and 16-bit which is a short node. It is designed to produce a clock speed ranging from 80 to 160 MHz's. Its antenna is on-board with the module itself. This module is a wireless system on a chip (SOC). It is embedded to host separate application for both web and mobile platforms with both a lesser cost and space.

#### F. Bluetooth IC

The proposed device requires a module to transmit the real time live data to an Android based mobile application. For the purpose, we are using a Bluetooth He-05 sensor. This sensor can be paired with the mobile device of the patient's caretaker and the hospital management. It supports Bluetooth version 2.0 and hosts enhanced data rate with a file transfer rate of 3 Mbps and a bandwidth of 2.4 GHz. It is a single chip Bluecore 04 based system and comes with adaptive frequency hopping and CMOS. Its dimensions are 12.7 x 27 millimeters.





Fig: 7 Bluetooth HC-05

### III. Working of the System

#### A. Proposed system:

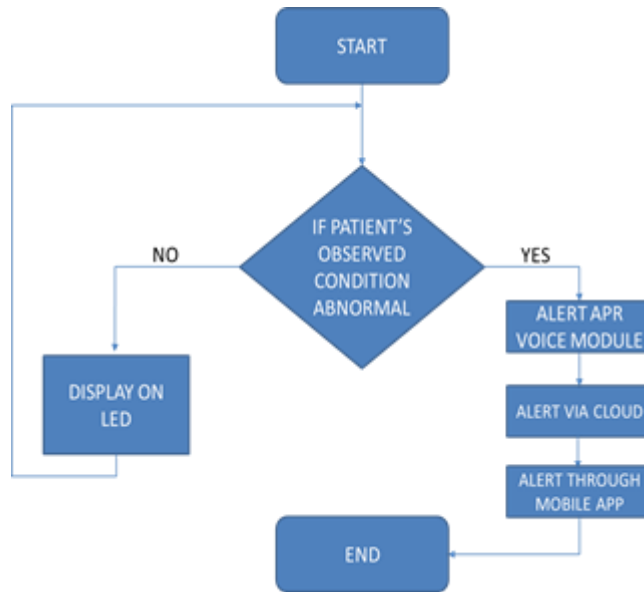

Fig: 10 Flow diagram for the proposed system

The above flow diagram shows the alert-based system for predicting a wake-up stroke.

#### B. Implementation:

##### 1. Step I: Detection of symptoms:

The patient is within the vicinity of the hospital, where the device is connected through wearable equipment. When a victim is experiencing any primary symptom of a wake-up stroke, i.e., any of the body sensor shows an abnormal value, it collects the data and transmits to the Arduino Mega microcontroller.

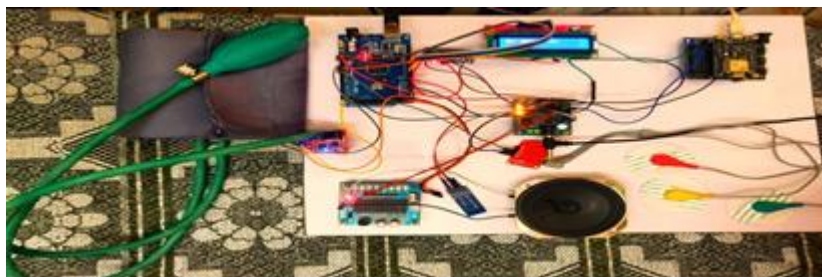

Fig: 12 Image of the working device

2. Step II: Collection of live data:

The Temperature, IR pulse, Brain EEG and Blood pressure sensor collects data from the victim. This set of live data is updated on the microcontroller. This data is now updated on a cloud computing-based host using NodeMCU (ESP8266). The NodeMCU updates all the live data on the alert system designed for immediate treatment of the victim by the doctor or the care-taker.

3. Step III: Alert System based on voice:

Now, the sensor's live data is transmitted to the NodeMCU for updating on the alert system. Before updating on the ESP8266, it triggers a primary level of alert through voice commands using APR9600 voice IC. This alert is for the nearest authority within the vicinity of the patient to alert and start treatment effectively.

4. Step IV: Alert System on webpage:

The NodeMCU is used to update the sensors live data on a dedicated web-page. This web-page is monitored throughout by the emergency department just in case if the victim experiences any symptom leading to a wake-up stroke. This is a secondary level alert of the device. The webpage is developed by using Php scripting. The NodeMCU updates the data to the web-page using a cloud computing-based network.



Fig: 13 Web-page

5. Step V: Alert System on Mobile Application:

Now, the sensor's live data is to be updated on the mobile application as a tertiary level alert. The data is acquired by the Bluetooth HC-05 Sensor. This sensor updates all of the victim's data continuously to a mobile device, which is connected to the device via Bluetooth. The mobile application is included in the device for a seamless connectivity and to consider the health of the patient as the primary concern. The mobile application is based Android Operating System. It is developed using Android Studio.



Fig: 14 Mobile Application

6. Analysis and Predictions based on sensor data

With the given set of sensor's live data collected in real-time, we can deploy a statistical analysis of the patient's health vitals and can predict an event of an occurring stroke in the near future. This enables the doctor and the health department to examine the patient more accurately and for a better diagnosis. The sensor data is in the form of PLX data-set. This data is acquired and analyzed with the help of Python programming and we obtain the statistical data. Some specimen of the data is given below. This includes

various statistical analysis of the sensor data which in turn guides to predict the possibility of a stroke happening to a victim in the near future.

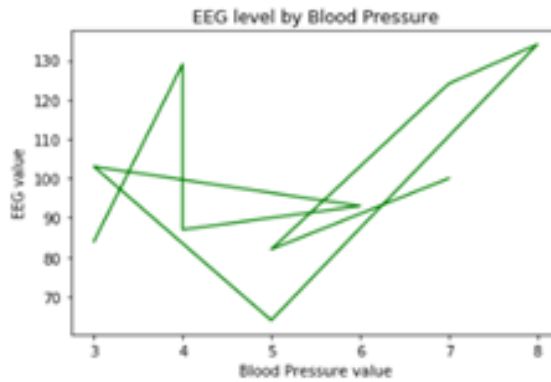

Fig: 15 EEG level by Blood Pressure

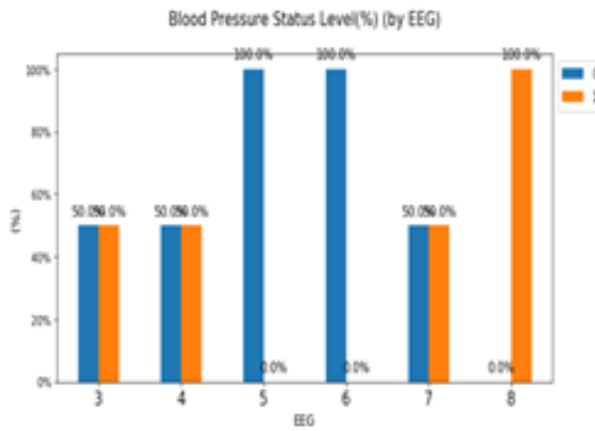

Fig: 16 Blood Pressure value by EEG

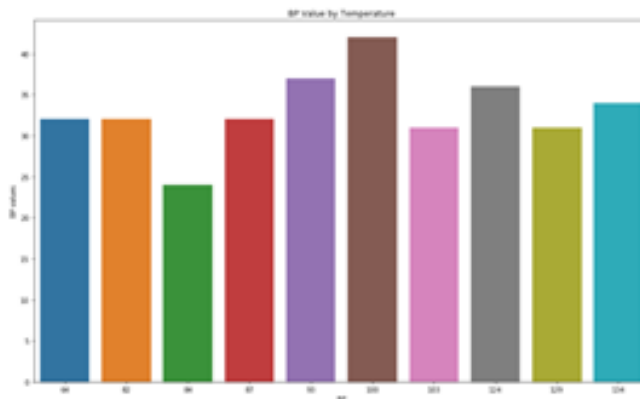

Fig: 17 Blood Pressure value by Temperature

#### IV. Conclusion

This paper is based on IoHT (Internet of Health Things), which is basically the implementation of IoT in the field of medical sciences. This proposed system is an attempt to prevent the threat of stroke by an intelligent prediction and alert-based system. The principal concern is to prevent the time consuming for medication for a victim suffering from any symptoms of a wake-up stroke. As we know that the causes of death around the world has increased rapidly because of stroke, especially for people over age 60. This system can prevent such fatal occurrences and prioritizes emergency medical assistance and rapid diagnosis from doctors.

#### V. References

1. P. V. Weerdesteyn, M. de Niet, H. J. van Duijnhoven, and A. C. Geurts, "Falls in individuals with stroke," 2008.
2. K. H. Jung, S. H. Lee, B. J. Kim, et al., "Secular trends in ischemic stroke characteristics in a rapidly developed country," *Circulation: Cardiovascular Quality and Outcomes*, Vol. 5, pp. 327-334, May, 2012.
3. B. M. Gund, P. N. Jagtap, V. B. Ingale, R. Y. Patil, "Stroke: A Brain Attack," *IOSR Journal of Pharmacy*, Vol. 3, No. 8, pp. 01-23, September, 2013
4. *The Atlas of Heart Disease and Stroke*, WHO, 2016.
5. Fan Zhang, Peter Bohlen, Michael D. Lewek, and He Huang; "Prediction of Intrinsically Caused Tripping Events in Individuals with Stroke", August 2017.
6. Murali Subramaniyam, Seung Hee Hong, Da Mee Kim, Jaehak Yu, Se Jin Park; "Wake-up Stroke Prediction through IoT and its Possibilities", February 2017

---

# A Biometric Based User Authentication and Key Agreement Protocol for Internet Integrated Wireless Sensor Networks

AK Suntheya and Dr. R Geetha

Department Of Computer Science and Engineering  
S.A. Engineering College  
Chennai, India

---

**ABSTRACT:** *Wireless Sensor Networks (WSNs) will be integrated into the future Internet as one of the components of the Internet of Things, and will become globally addressable by any entity connected to the Internet. Despite of its potential integration it also brings new threats, such as the attacks originating from the sensor nodes via Internet. In this context, authentication and key agreement protocol is been placed to enable end-to-end secure communication. In the earlier case, it makes use of Two-factor user authentication which results inefficient security over the resources. The protocol suffers from loss of data where the user identity and password can be guessed with the offline brute force techniques and also Known Session-Specific Temporary information attack thus results in the disclosure of session keys in other sessions. To overcome the earlier challenges, in this current system presents an authentication and key agreement protocol (AKP) based on the Rabin cryptosystem which has the characteristic of computational and present a comprehensive heuristic analysis of secured data against all the possible attacks with the desired security features.*

**Keywords:** *Wireless Sensor Networks, Known Session-Specific Temporary Information Attack, Authentication and Key agreement protocol*

---

## 1. Introduction

Large-Scale sensor networks are deployed in numerous application domains, including medical monitoring, environmental monitoring, surveillance, home security, military operations, industrial machine monitoring, etc[1][4]. In these application domains, sensors vary from miniature, body-worn sensors to external sensors such as video cam-eras or positioning devices. The diversity of such network environments requires adopting techniques that can ensure the trustworthiness of data across the network. Since provenance records the history of both data acquisition and transmission, it is considered as an effective mechanism to evaluate the trustworthiness of data. It also provides the information about the operations performed on data[2]. However, reducing the size of the provenance is crucial in large-scale sensor networks. Sensor nodes in these networks may not be able to record and manipulate very large provenance data due to storage and computational resource constraints. Besides, transmission channels may not have sufficient capacity for transmitting large provenance data[3][5]. Although most of the recent approaches focus mainly on provenance modeling, collection, and querying, a few of them address the size and trustworthiness of provenance in sensor networks.

## II. Related Works

[6] D. He and S. Zeadally, et.al have discussed about the identity-based PKC in the authentication protocol. Major challenges facing the AAL field in the coming years is to reach the goal of openness for achieving more interoperable and synergetic AAL solutions that can gather the critical mass needed for succeeding with our efforts as a field. This challenge could arguably be conceived as the largest barrier to overcome.

[7] Saru Kumari et.al implemented a proposed authentication scheme for WSN based on chaotic maps for mutual authentication proof they have used BAN logic but there are many complexities and security issues.

[8] Qi Jiang et.al have discussed about the Mutual authentication using the Burrows-Abadi-Needham logic. Vulnerable to user impersonation attack and off-line password guessing attack if the smart card is lost or stolen.

[9] R. Lumini et.al implemented an improved BioHashing approach using feature permutation for authentication. It is very much time consuming and thus its been unacceptable for a real-time application

[10] Z. Liu et.al have discussed about the Elliptic Curve Diffie-Hellman (ECDH) key exchange, generation and verification of an ECDSA signature are employed to achieve authentication. Really it is more complex and

difficult to implement than Rabin cryptosystem, which increases the likelihood of implementation errors, thereby reducing the security of the algorithm.

### III. System Execution

The users will initially in need of accessing the resources from the cloud resources which is been placed in the internet. They cannot able to retrieve the information in an easier manner since the WSN will be keeping the data in a secure manner. In order to access the information from the internet the users must be registered with their id's and smart card for their personal identification. After providing themselves with their personal information the users must sent their id's to the system administrators for their authorization to access the information from the internet. System Administrator need to identify whether the registered users are authorized or unauthorized users in order to protect the information from the attackers. Then System Administrator after verification of the authorized users they will allow the users to access the data from the internet. The users will now access the data by initially placing their id's in the system to get the prior permission from the administrator. After insertion of their id's the user will provide their user id and password for processing the required content from the resources. Then the user can able to access the data from the internet by selecting their desired sensor node which will provide the data only with the recognized users whom are authorized. The sensor nodes will then generate with the session keys for their authorization over the system to interact accordingly upon with their identification and also to maintain the data in a confidential manner. After the generation of the session keys then the data will be kept in encrypted form and the data will be send to the gateway node along with the encrypted form. Then verify the session keys and then send the keys for confirmation to the sensor nodes for the further protection over the information. Again the sensors node will verify the session keys and then it will provide the user desired data from the internet in the decrypted manner. Finally the authorized users ca able to access from the internet.

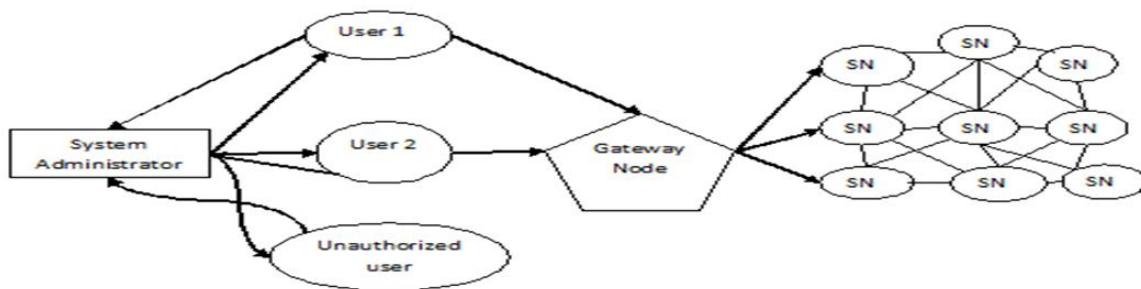

Fig: System Architecture

### IV. Results and Discussion

The proposed system process according to an authentication protocol for Internet integrated WSN which exploits the computational asymmetry feature of Rabin cryptosystem. Unlike other public key-based encryption algorithms such as RSA and ECC, Rabin has the characteristic of computational asymmetry. Thus, the encryption process is very efficient while the decryption is relatively heavyweight. This feature is particular well suited for Internet integrated WSN because the mobile device of users is generally resource-constrained while the gateway has no such restriction.

**User Registration:** In this phase the registration of users takes place in order to access the data from the network and validate themselves as authenticated users during the transmission of messages.

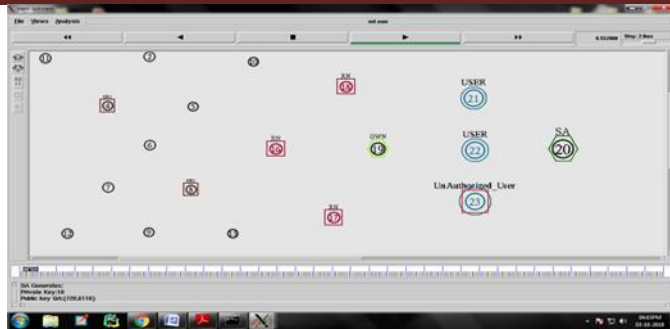

Fig : User Registration

Data Transmission :In this phase the transmission of messages take places from the users to system administrator via the gatewaynodes .From the gateway nodes the information is transmitted to sensornodes and then reach the desired users in an encrypted form.

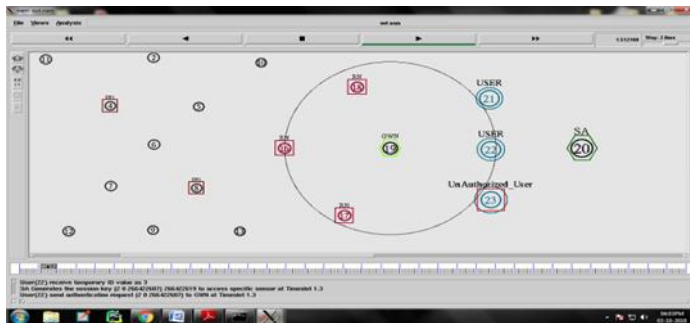

Fig: Data Transmission

Data Evaluation: In this phase the evaluation of data is been calculated .That is how much time is been taken to access required information.

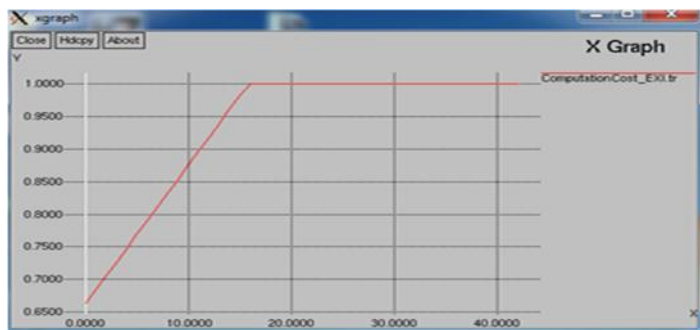

Fig: Data Evaluation

## V. References

1. B. Lynn, "PBC Library," Available: <https://crypto.stanford.edu/pbc/>
2. Microsoft, "SuggestedBoards and SoCs," Available: <https://docs.microsoft.com/en-us/windows/iot-core/learn-abouthardware/suggestedboards>
3. [https://en.wikipedia.org/wiki/Elliptic-curve\\_cryptography](https://en.wikipedia.org/wiki/Elliptic-curve_cryptography)
4. [https://en.wikipedia.org/wiki/Rabin\\_cryptosystem](https://en.wikipedia.org/wiki/Rabin_cryptosystem)
5. [https://developer.mozilla.org/enUS/docs/Archive/Security/Encryption\\_and\\_Decryption](https://developer.mozilla.org/enUS/docs/Archive/Security/Encryption_and_Decryption)
6. D. He and S. Zeadally. January 2015. Authentication protocol for an ambient assisted living system," in IEEE Communications Magazine, vol. 53, no. 1, pp. 71-77.



7. Saru Kumari .Xiong Li.Fan Wu . Ashok Kumar Das .Hamed Arshad . Muhammad Khurram Khan. October 2016.A User Friendly Mutual Authentication And Key Agreement Scheme For Wireless Sensor Networks Using Chaotic Maps,Volume 63.
8. Qi Jiang.Fushan Wei. Shuai Fu.Jianfeng Ma. Guangsong Li. Abdulhameed Alelaiwi.2016,83>4>2085-2101.Robust extended chaotic maps-based three-factor authentication scheme preserving biometric template privacy .
9. An improved BioHashing for human authentication Author links open overlay panel Alessandra Lumini Loris Nanni, DEIS, IEIIT – CNR, Università di Bologna, Viale Risorgimento 2, 40136 Bologna, Italy.
10. Efficient Implementation of NIST-Compliant Elliptic Curve Cryptography for 8-bit AVR-Based Sensor Nodes,IEEE Transactions on Information Forensics and Security,Volume 11,Season 7,July-2016.

# Conversion of Neutral Speech to Emotional Speech using GMM-Based Techniques

KL Shreya Narasimhan, Sharon Sengole Rayan, TG Narayanan, S Niveditha

Department of Computer Science and Engineering  
SRM Institute of Science and Technology,  
Chennai, India

**ABSTRACT:** Research in Speech Synthesis by far has primarily focused on producing natural sounding speech rather than emotional speech. In this paper, the proposed system is expected to transform the neutral, emotionless speech into emotional speech to convey specific emotions like Anger, Sad, Happy, Pleasant Surprise, Fear and Disgust. The way of approach to train the conversion models include three methodologies: 1) Joint Density Gaussian Mixture Model (GMM), 2) Differential GMM and 3) F0 Transformation with Differential GMM, all of which have shown promising results in voice conversion for masking speaker identity. Experiments conducted using Toronto Emotional Speech Set (TESS) Database indicates that the proposed models implement the task with an accuracy of 85.92% at converting neutral sounding speech to emotional sounding speech.

**Keywords:** Emotional Prosody, Speech-to-Speech, GMM, DIFFGMM, TESS

## 1. Introduction

The most commonly used audio files in Text-to-Speech and Speech-to-Speech conversions sound neutral and robotic. Areas of research in the field of Voice Conversion are growing and this paper aims to find out the most suitable algorithm to employ for making neutral speech sound emotional. It involves applications of various streams like phonetics, linguistics, audio pattern recognition etc. Fundamentally this paper focuses on conversion of Neutral Speech Signal to Emotional Speech Signal by applying "Gaussian Mixture Model" (GMM) (Toda, 2007) and a differential method based on Gaussian Mixture Model (DIFFGMM) (Kobayashi, 2014). The architectures were based on the open source voice conversion toolkit sprocket-vc (Kobayashi, 2018). An additional method involves conversion of the F0 of neutral speech using fundamental frequency ratio and then training a model for conversion with the differential spectrum. The motive behind using three different models is to compare and contrast the differences in the results of each method and to estimate the most accurate method and emotion.

## 2. Pre-Processing

### 2.1 Dataset Collection

The Dataset used for the training purposes was collected from TESS (Dupuis, 2010) Toronto Emotional Speech Set, which consists of recording of two actresses that portrayed seven emotions (6 emotions + neutral). Since these actresses had musical training, the audio metric testing showed that their thresholds were of the normal range. There are 200 utterances per emotion, which makes it 2800 files of each 2 seconds long.

The recordings were done at 24414 Hz Sampling Frequency, with bit-rate of 16 bits. However, all the samples were converted to 22050 Hz Sampling Frequency as it is ideal for working with certain libraries and tool kits. 80% of the data set was used for training, 20% was used for evaluation.

### 2.2 Feature Extraction

F0 range was generated for each emotion and it was used to draw the histogram plot to configure the emotion specific min and max F0. Acoustic features were also extracted from each of the audio file to differentiate and categorize the emotions.

### 2.3 Statistics Generation

Statistical Parameters like Mean, Standard Deviation of logarithmic F0, and the general Variance of the Mel-Cepstrum were calculated for applying a filter post-conversion.

### 3. Training

In this paper, the following stages are applied to obtain Gaussian Mixture Models. Two models are trained : Model 1) A model without prior F0 Transformation, Model 2) A model with F0 Transformation using “Waveform-similarity based overlap and add” (WSOLA) (Verhelst, 1993) of Neutral Speech based on the frequency ratio of the desired emotion (Kobayashi, 2016).

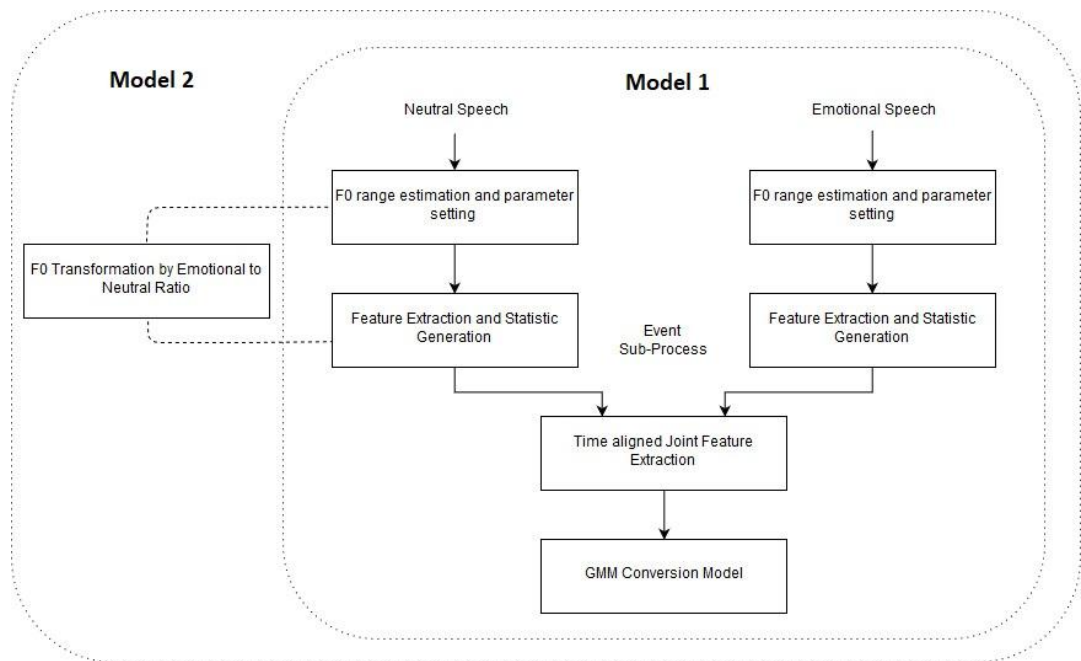

Figure 1: Architecture Diagram of the Training Phase

#### 3.1 Time Alignment

“Dynamic Time Warping” (DTW) (Sakoe, 1978) is used for time alignment between neutral and emotional feature vectors by minimizing the Mel-Cepstral distortion as a distance metric.

#### 3.2 Joint Feature Extraction

Joint Probability Distribution Function is used to characterize the probability distribution of the continuous vector (Kobayashi, 2018). It is trained based on Expectation Maximization algorithm using Joint Feature Vectors.

#### 3.3 Iterative Refinement of Joint Feature Vector based on GMM

The feature vectors of the source with silent parts are converted to the target using “Maximum Likelihood Parameter Generation” (MLPG) method (Kobayashi, 2016). These steps are repeated on the resulting feature vectors to further refine the learnt model.

### 4. Conversion

#### 4.1 GMM

This method involves generation of an excitation signal using F0, followed by mel-cepstrum modification using Model 1:

##### 4.1.1 F0 Transformation

Linear transformation of F0, frame by frame using the emotion-dependent statistics in the logarithmic space.

##### 4.1.2 Mel-Cepstrum Conversion

MLPG is used to convert the neutral waveform's Mel-Cepstrum into the target emotion.

### 4.1.3 Converted Voice Generation

An excitation signal is generated and the Mel-Log Spectrum Approximation (MLSA) filter (Tokuda, 1994) uses the transformed F0 and Mel-Cepstrum parameters to generate the converted signal.

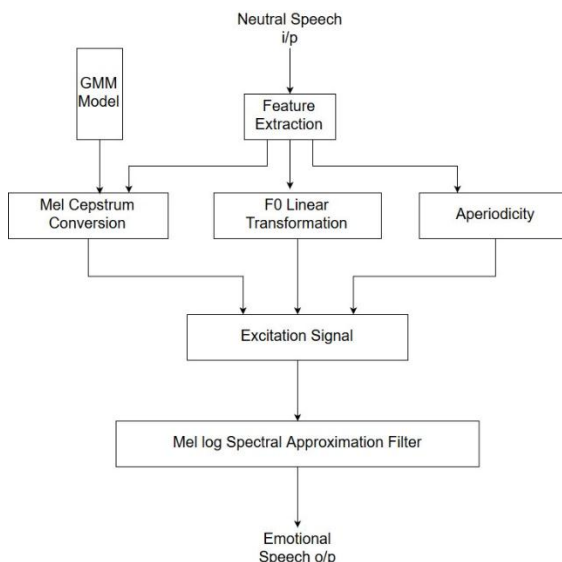

Figure 2: Architecture Diagram of GMM Conversion

## 4.2 DIFFGMM

This method involves direct modification of the neutral waveforms mel-cepstrum using Model 1:

### 4.2.1 Parameter Modification

Joint probability densities of the neutral waveform and target emotion are used to generate a feature differential between the source and target features.

### 4.2.2 Mel-Cepstrum Estimation

The converted Mel-Cepstral differential is estimated from the source Mel-Cepstrum.

### 4.2.3 Waveform Modification

Directly modify the input waveform's spectral features using the differential Mel-Cepstrum, to generate the output.

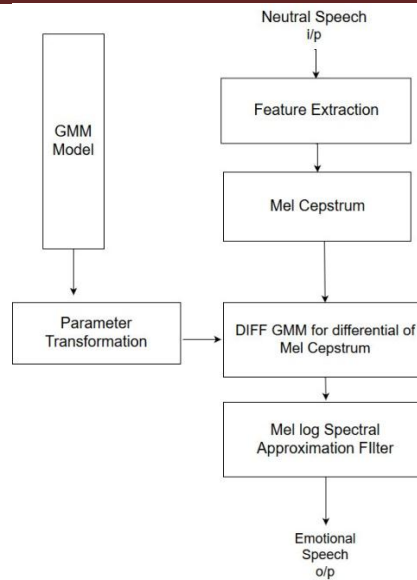

Figure 3: Architecture Diagram of DIFFGMM Conversion

#### 4.3 DIFFGMM After F0 Transformation

This method involves first modifying the fundamental frequency of the neutral waveform, and then converting its mel-cepstrum using Model 2:

##### 4.3.1 F0 Transform of Source Waveform

The fundamental frequency of the source waveform is converted to match the frequency range of the target emotion.

##### 4.3.2 Mel-Cepstrum Estimation

A Mel-Cepstral differential is estimated for the F0-transformed waveform using the joint probability densities of the GMM.

##### 4.3.3 Waveform Modification

Directly modify the F0-transformed input waveform's spectral features using the differential Mel-Cepstrum, to generate the output.

### 5. Analysis and Results

The evaluation set of neutral speech was converted to each emotion using the different techniques, and the Mel-Cepstral distortion was calculated between the outputs and the corresponding emotional files of the dataset.

Table 1: Mel-Cepstral Distortion Between Evaluation Set and Target

Emotion	GMM	DIFFGMM	F0-DIFFGMM
Angry	15.73907	15.67080	16.27771
Disgust	12.81158	12.77651	13.22706
Fear	15.62328	15.64046	16.41926
Happy	13.99928	13.92284	14.44820
Pleasant Surprise	13.96516	13.90996	14.21475
Sad	11.50867	11.44176	11.91134
AVERAGE	13.94117	13.89372	14.41639

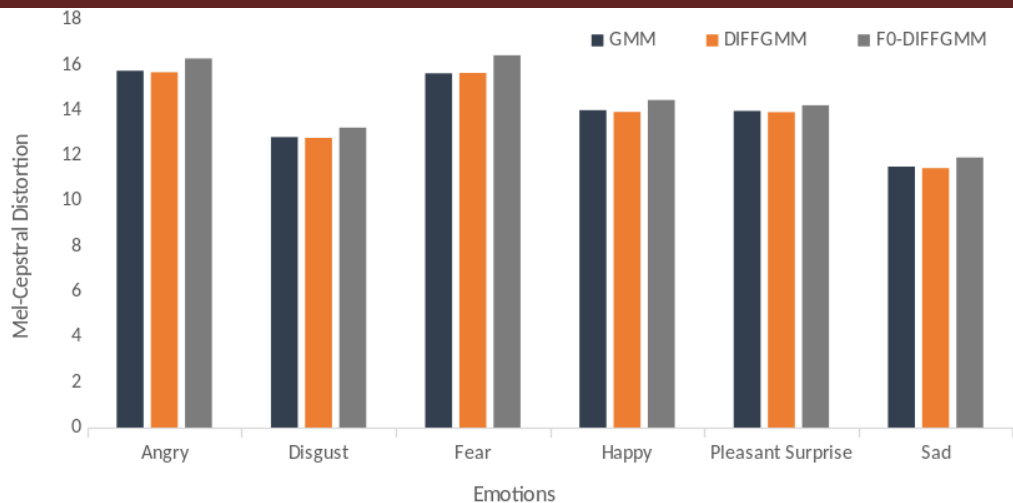

Figure 4: Plot of average Mel-Cepstral Distortion by Emotion

The obtained results indicate that the most accurate voice conversion is of Sadness with DIFFGMM. The average results of each technique indicate that the Mel-Cepstral distortion is least for DIFFGMM, followed by GMM and lastly F0-DIFFGMM.

## 6. Conclusion

Results are promising for converting neutral to emotional speech on training a model with a parallel dataset for a specific speaker. The accuracy of the experimental system after training on 1.5 hours of speech was 85.92%. The GMM outputs obtained sound emotional, with comparatively more noise due to the generation of an excitation signal. DIFFGMM technique reduces the noise level of the output. However, since the F0 is not modified, the speech sounds less emotive than GMM. F0-DIFFGMM method combines the advantages of both methods by modifying the F0 range without generating an excitation signal. The scope of the proposed system is to extend the training over larger datasets for multiple speakers so that a generalized model can be learnt. Such a generalized model can be used to introduce emotions to speech samples of any speaker, and therefore can be added as a module to the end of any speech synthesis system. As the focus of research in text-to-speech is for developing natural-sounding speech, sentiment analysis can be performed in parallel. The obtained speech and emotion pairs can be used as input to the proposed system to obtain output that is both natural-sounding and emotive.

## References

1. Kobayashi, K., Toda, T., (2018) "sprocket: Open-Source Voice Conversion Software", Conference: Odyssey 2018 The Speaker and Language Recognition Workshop.
2. Toda, T., Black, A. W., Tokuda, K. (2007) "Voice conversion based on maximum likelihood estimation of spectral parameter Trajectory", IEEE Trans. ASLP, vol. 15, no. 8, pp. 2222-2235.
3. Kobayashi, K., Toda, T., Neubig, G., Sakti, S., Nakamura, S. (2014) "Statistical singing voice conversion with direct waveform modification based on the spectrum differential," Proc. INTERSPEECH, pp. 2514-2518.
4. Kobayashi, K., Toda, T., Nakamura, S. (2018) "Intra-gender statistical singing voice conversion with direct waveform modification using log-spectral differential," Speech Communication.
5. Kobayashi, K., Toda, T., Nakamura, S. (2016) "F0 transformation techniques for statistical voice conversion with direct waveform modification with spectral differential," Proc. IEEE SLT, pp. 693-700.
6. Tokuda, K., Yoshimura, T., Masuko, T., Kobayashi, T., & Kitamura, T. (2000). "Speech parameter generation algorithms for HMM-based speech synthesis". Acoustics, Speech, and Signal Processing, IEEE International Conference. 1315-1318.
7. Sakoe, H., Chiba, S. (1978) "Dynamic programming algorithm optimization for spoken word recognition", IEEE Transactions on Acoustics, Speech, and Signal Processing. Volume: 26 , Issue: 1, 43 - 49.

8. Verhelst, W., Roelands, M. (1993) An overlap-add technique based on waveform similarity (WSOLA) for high quality time-scale modification of speech, Proc. ICASSP, vol. 2, pp. 554-557.
9. Dupuis K., Pichora-Fuller, M. Kathleen, (2010) "Toronto Emotional Speech Set (TESS) Collection".
10. Tokuda, K., Kobayashi, T., Masuko, T., Imai, S. (1994). "Mel-generalized cepstral analysis - A unified approach to speech spectral estimation". Proc. ICSLP.
11. Tokuda, K., et al. (2000) "Speech Parameter Generation Algorithms for HMM-Based Speech Synthesis". IEEE International Conference on Acoustics, Speech, and Signal Processing.



# A Novel Approach To Manage The Maintenance Cost And Electricity Consumption In Cloud Data Centers

M Rajavel, Noeline Lincy Jeba PS, Deepa S

<sup>1</sup>Assistant Professor, Department of Computer Science and Engineering, SRM Institute Of Science And Technology, Vadapalani, Chennai, India

<sup>2,3</sup>UG Student, Department of Computer Science and Engineering, SRM Institute Of Science And Technology, Vadapalani, Chennai, India

---

**ABSTRACT:** *Cloud computing deliver services through the internet in our everyday life. Cloud data centers are becoming very popular for providing computing resources. Cloud computing providers are profoundly concerned with energy consumed becoming the major issue for the application and preservation of cloud data centers. Resource allocation is a main problem that has to be considered in the progression of energy consumption. Better performance can be achieved by sharing the workload within least number of servers that can eventually bring significant energy savings. Effective methods like load balancing can be adopted to store and reduce the energy utilized in clouds. Therefore, we conclude the probable solution to lessen energy consumed is by using the Load Balancing and Advanced Encryption Standard (AES) Algorithm which eventually increases the cloud performance through the weighted least connection approach.*

**Keywords:** *Cloud computing, Cloud data centers, Load Balancing, Advanced Encryption Standard, Weighted Least Connection, Energy savings.*

---

## 1. Introduction

Data Centers (DCs) play a major role in the Information and Communication Technology (ICT) sector. Factors such as security, reliability, data availability, scalability, fault tolerance, and sustainability [1] making cloud attaining limelight in the industry. Realization of energy consumption will thereby reduce the amount of energy consumed through energy aware approach. These processes are based upon resource allocation techniques with the goal of decreasing the energy consumption [2]. By applying the weighted least connection technique highest performance can be achieved and by introducing a CPU reallocation reduced power consumption can be attained. Better performance can be achieved by sharing the workload within least number of servers that can eventually bring significant energy savings. A series of tasks with different properties will be exhibited by this work. Any given available cloud resource can be used to manage the task. A cloud computing resource has a certain ability (e.g., Central Processing Unit, RAM, Network, Hard drive). In spite of, other resources which are continuously available one resource mainly focuses on the task at one time. Identifying and evaluating Load Balancing and Advanced Encryption Standard (AES) which is used to improve the energy consumption is the main aim of this paper.

However, the other part of the paper consists of : Literature review is given in Section 2. Related work is presented in Section 3. The architecture diagram is illustrated in Section 4. The investigated algorithm is introduced in Section 5. The experiments and the results of the paper is presented in Section 6. Finally, Conclusion is presented in Section 7.

## II. Literature Review

After a survey we have come to know that the users don't want to lose their money and time in this process. Hence, they are ready to implement load balancing which is an easy, rapid and error free technique. Netflix, Amazon uses load balancing to balance their load in data centers. Nowadays, there are many technological advancements to secure load balancing of data.

### 2.1 Existing System

The existing system merely concentrates on the provider or end users benefit. First the end users benefit is reviewed using the

Nash Bargaining Solution, the problems that a cloud faces in the real time environment are presented using an optimization method. Optimizing traffic in ISPs, the requests are simply allocated to the point close by is proposed. Based on the demand supported locality policies for the network is framed.

## 2.2 Issues in Existing System

- This locality policy depends on the infrastructure for end users nearby a good performance on the other hand reduced performance for users far away.
- Their work is primarily targeted on one data center. However, our work is different from this since request allocation in multiple datacenters is concentrated.
- In an attempt to minimize the electricity cost does not reduce the distance among end users and data centers by using the problem of optimization.

## 2.3 Summary Of Literature Review

### 1. Title: Closestnode.com: An Open - Access, Scalable, Shared Geocast service for Distributed systems

Authors: B. Wong and E. G. Sirer.

- Description : ClosestNode.com is a service which is precise, accessible, and backwards-compatible for allocating customers to a close server . The aim is to offer proximity-based server selection by reducing the amount of work for distributed system builders.
- Methodology : A DNS interface is provided by ClosestNode.com in which clients who are unmodified can look up a service name, and get the IP address of the nearby server. The management and application costs for the selection of a server is done using a shared system. The goal of this is to create services that has new and current infrastructure for system developers by reducing the amount of effort needed.
- Challenges : Mappings according to geographical region based on IP address is implemented through Selection schemes can minimize in a database the closest node discovery latency, they are delicate, when changes in an IP address arise and accuracy is low when compared to passive or active selection schemes.

### 2. Title: The Cost of a Cloud: Research problems in Data Center Networks

Authors : A. Greenberg, J. Hamilton, D. A. Maltz, and P. Patel.

- Description : The services in cloud has a direct impact on the investment and the overall cost of the datacenter. First the cost of a cloud service in a data center is taken into account. The optimization work reveals the breakdown of cost and the money invested in it. Resource stranding and fragmentation become the main factors for the resources to operate at low utilization. To clear this problem, we implement increased network agility and provide proper consumption of resource providing suitable incentives is given. On the other hand, geo-distributed networks are built by cloud service providers. Latency is lowered to users and reliability is increased by Geo-diversity in the entire process.
- Methodology : Two Fuzzy IBE schemes is presented in this paper. The message is regarded as an Identity-Based Encryption with several attributes. Against collusion attacks, IBE schemes is tolerant to error and secure. Moreover, random oracles is not used in our primary construction. The security of the model is proved using Selective-id.
- Challenges : The cost of the service provided will be raised without correct management and design of the data center networks. Geo-diversity services are designed such that maximum benefit is obtained. To solve this issue, we implement joint optimization of network and data center resources and Geo-distributing state for new systems and techniques.

## III. Related Work

By using Internet there are many offers to access data, computation and applications via cloud computing [3]. The pay-per-use model allows Cloud customers to only pay for what they utilize in a cloud environment. The advantages of Cloud computing being used will be emphasized only when researchers sought out the numerous issues. These issues arising are in respect of security, certainty of data, unpredictable performance and data efficiency.

In cloud data centre one of the technique used to reduce the energy consumption is by Load balancing [4]. This technique is implemented by distributing the workload across servers. When the request is made, it is sent to the available servers and not the loaded servers. So to increase the performance level, services such as File Transfer Protocol (FTP) is used.

These days, the main factor in industry and academia is Green cloud computing [5]. In order to achieve this, effectual scheduling algorithms which considers energy consumed and QoS conditions such as high computation capacity in spite of the challenges faced by it are taken into account.

Finding solutions and methods to have less energy consumption in cloud data centers has direct connection with Efficient energy consumed [6]. The maximal profit can be attained by shutting down unutilized and inactive servers.

#### IV. Architecture

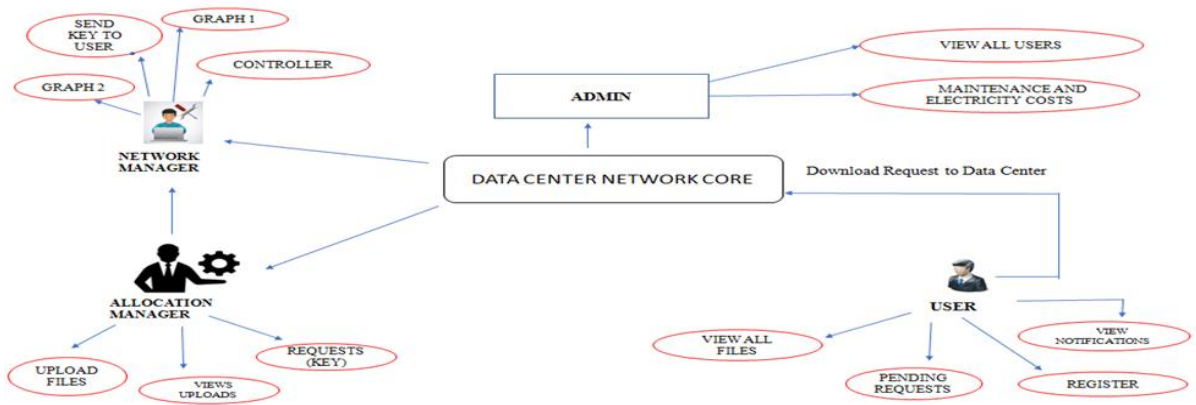

Fig. 1: Architecture diagram

##### 4.1 Allocation manager ( mid- left part of the above mentioned figure ):

The allocation manager is in charge of uploading the files. Is able to view all the uploaded files in the cloud. Sends the key to the networking manager.

##### 4.2 The User ( bottom right of the above mentioned figure ):

The user gives the request to the datacenter for downloading the file. The user sees the status of the files requested for.

The register module is for those who has not registered as a user. The user can download the files they requested.

##### 4.3 A networking manager ( top - left part of the above mentioned figure):

The networking devices are controlled by the networking manager, which is the controller. Sends the key to the user to download the requested file. Can view which datacenter is loaded. Shows the graph 1 based on the File Request Time. Shows the graph 2 based on the File Name.

##### 4.4 The Admin (top right part of the above mentioned figure):

Is responsible for the Maintenance and Electricity consumption and can view all users.

#### V. Investigated Algorithm

In this segment, we present the primary fact regarding Load Balancing and Advanced Encryption Standard which is deployed to improve the efficiency of energy consumed and performance in the cloud.

##### 5.1. Load Balancing

Load Balancing [7] became more efficient and less costly. In spite of the server remaining idle in data centers cloud resources utilizes a huge amount of power. Reducing power has a good effect on the overall cost. Nowadays, the conventional single applications data centers has been replaced by the virtualized data centers. The system performance is increased in terms of scalability or energy consumed through Load Balancing. Weighted least connection is based on the least counted data center. For achievement of the energy control approaches, the requests will be given to the data center with the next highest request if the datacenter is loaded. The aim of using Load balancing is response time, efficiency of application anywhere and anytime, the capacity of datacenters in which the application is given can be made constant. In this paper we present a Load balancing technique, Weighted least connection, to highlight the significance of

initiated material. The problem of optimization with certain resource constraints is always to be considered for the load balancing problem.

## 5.2 Advanced Encryption Standard

Compared to other algorithms, the benefits of implementing AES [8] for secured data results in less memory consumption and computation time. In spite of varied security strengths, the user can choose his own security infrastructure. Cloud providers have their own rules, prices, support, flexibility and other important regulations. The encryption schema is the key factor dealt to secure data. Key length can be: 128, 192 or 256 bits. We process data with a key length of 128 bit and AES is a block cipher. The encryption process consists of 10 rounds of processing. The rounds are identical, except the last one. The key schedule is an expansion of 4 byte words which is in the form of a 16 byte encryption key. The state array is referred as a 128 bit input block. With the first four words of the slot input state is XOR, for encryption to begin.

## VI. Experiments and Results

In this section, the result is achieved by allocating the requests through Weighted Least Connection in Load balancing and Advanced Encryption Standard algorithm which ponders on low delay for users and bandwidth utilization for provider, which results in low cost. The valuation process uses Java EE framework. Java EE is an existing framework used in performing and implementing cloud base algorithms. This enables researchers to work on various algorithms without involving low level aspects. Is used to access different cloud base because of the following reasons [9],[10]:

- For allocating the host resources to virtual machines flexible policies is been declared, by allowing users of the cloud environment to begin and simulate large virtual data centers.
- Different network topologies are given in data centers, which supports modelling and simulates energy-aware computational resources.
- Capacity to allocate host machines to VM's for the successive actions is offered.

### 6.1 Performance Comparison

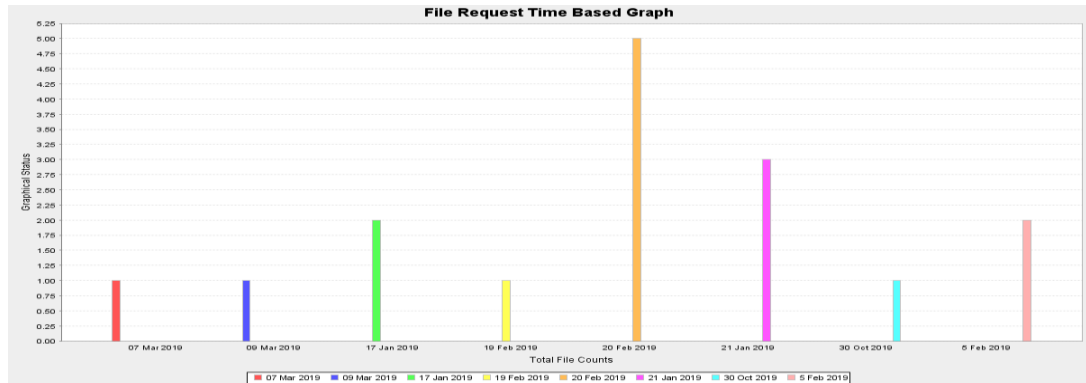

Fig. 2: File request time based graph

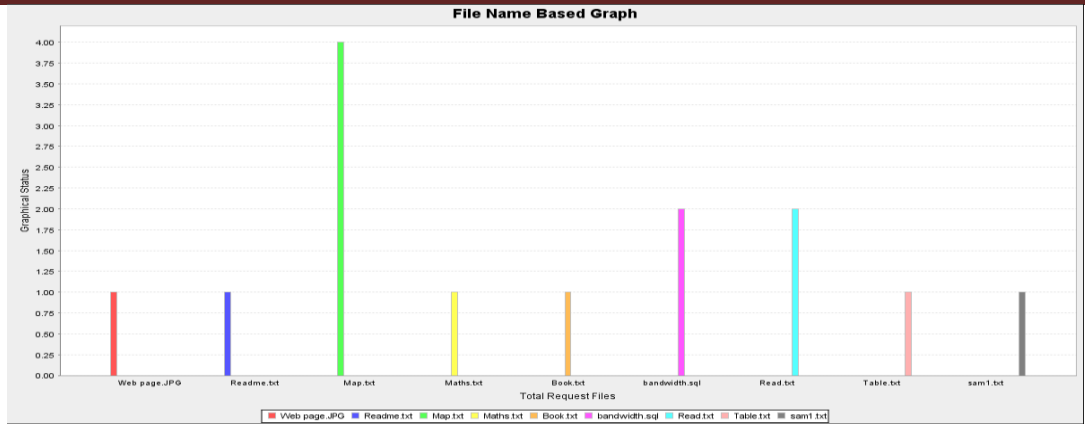

Fig. 3: File name based graph

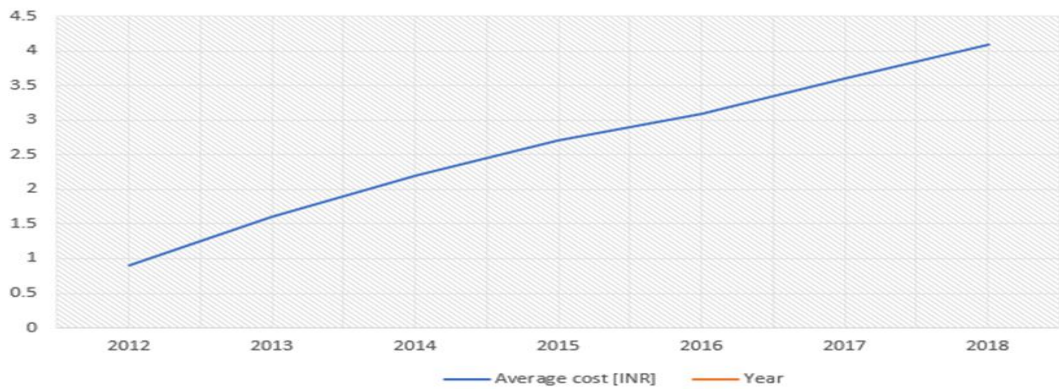

Fig. 4: Electricity consumption (Average cost)

## VII. Conclusion

In this paper we implement the Weighted least connection in Load balancing and Advanced Encryption Standard in the cloud environment. Load balancing is a major problem that can be used to conserve the energy utilized in cloud. To increase the effectiveness of cloud, there is always a need for applying different VM mechanisms. The algorithm mentioned earlier could be used to execute Load balancing. To stop the over utilization of machines and reduce the amount of CPU power by host machines, thereby decreasing energy is the benefits of deploying this algorithm. For future work enhancement factors like QoS level and service availability should be taken into account to provide best results using this algorithm.

## VIII. Acknowledgment

I wish to extend my gratitude to Mr. M. Rajavel, Asst. Professor, Department of Computer Science and Engineering,

Dr. S. Prasanna Devi, Head of Department, Department of Computer Science and Engineering and SRM Institute of Science and Technology, Vadapalani Campus, Chennai who supported, encouraged and provided us with requisite infrastructure to carry out this work successfully.

## References

1. M. Armbrust, A. Fox, R. Griffith, A. D. Joseph, R. Katz, A. Konwinski, G. Lee, D. Patterson, A. Rabkin, I. Stoica, et al., "A view of cloud computing," *Communications of the ACM*, vol. 53, no. 4, pp. 50–58, 2010.
2. Beloglazov, J. Abawajy, R. Buyya "Energy-aware resource allocation heuristics for efficient management of data centers for cloud computing, *Future Gener*", *Comput. Syst.*, Vol. 28 (5), pp. 755–768, 2012.
3. C.Tsaravas, and M. Themistocleous, "Cloud Computing and EGovernment: A Literature Review" *European, Mediterranean & Middle Eastern Conference on Information Systems.*, pp. 154-164, 30-31 May 2011.

4. M. Nirmala, and Dr. T.Adi Lakshmi, "Energy-Efficient Load Balancing in Cloud: A Survey on Green Cloud" International Journal of Engineering Trends and Technology (IJETT) – Special Issue – April 2017.
5. K. Bilal, S. U. R. Malik, O. Khalid, A. Hameed, E. Alvarez, V. Wijaysekara, R. Irfan, S. Shrestha, D. Dwivedy, M. Ali, et al., "A taxonomy and survey on green data center networks", Future Generation Computer Systems, vol. 36, pp. 189–208, 2014.
6. L. Lefèvre, L., A.C. Orgerie, A.-C "Designing and evaluating an energy efficient Cloud", J. Supercomput., v.51(3),pp. 352- 373, 2010.
7. Sajjan R.S , Biradar Rekha Yashwantrao, "Load Balancing and its Algorithms in Cloud Computing: A Survey", International Journal of Computer Sciences and Engineering , Volume-5, Issue-1 E-ISSN: 2347-2693, Jan. 2017.
8. Ako Muhamad Abdullah, "Advanced\_Encryption\_Standard\_AES\_Algorithm\_to\_Encrypt\_and\_Decrypt\_Data", June16 2017.
9. R. Buyya,R. Ranjan, R.N. Calheiros, "Modeling and simulation of scalable cloud computing environments and the cloud Sim Toolkit: challenges and opportunities" In: Proceedings of the 7th High Performance Computing & Simulation Conference (HPCS 2009), pp. 1– 11, 2009.
10. R. N. Calheiros, R. Ranjan, A. Beloglazov, C.A.F.D Rose, R. Buyya, "Cloud Sim: a toolkit for modeling and simulation of cloud computing environments and evaluation of resource provisioning algorithms." In: Software: Practice and Experience (SPE), vol.41(1), pp. 23–50, 2011.
11. Bernard Wong and Emin Gun Sirer, " ClosestNode.com: An Open-Access,Scalable,Shared Geocast Service for Distributed Systems." In SIGOPS Operating Systems Review,40(1), January 2006.
12. Greenberg, J. Hamilton, D. A. Maltz, and P. Patel, "The Cost of a Cloud: Research problems in Data Center Networks", ACM SIGCOMM Computer Communication Review, 39(1):68-73 · January 2009.



# Design and Implementation of Smart Safety Device Using Arduino Micro Controller

<sup>1</sup>R Hemalatha, <sup>2</sup>P Nanthitha, <sup>3</sup>M Rajavel

<sup>1,2</sup>Student, Computer science and engineering, SRM Institute of Science and Technology, Chennai, India

<sup>3</sup>Faculty, Computer science and engineering, SRM Institute of Science and Technology, Chennai, India

---

**ABSTRACT:** *The aim of this project is to create a smart band which is wearable and it can be connected with smart phone via phone Bluetooth. In addition we have included the taser. Taser is a device which produces a small amount of electric shock, which helps the victim to safeguard themselves from the attacker. In this device we are also going to include an alarm module. So, the user can use the alarm for safety purpose. When the alarm rings it grabs the attention of the surrounding people to save the person from the attacker. The mobile application which we have developed is used to send the current location of the user holding the mobile phone. The location can be sent along with an alert message to the predefined numbers that have been stored in the mobile application previously. The main benefit of this band is it can be easily operated and it is more convenient to use.*

**Keywords:** Smart Band, Taser, Alarm, Smart phone application

---

## 1. Introduction

In recent months, the rape, torture and murder of women even small children have been increased to a great extent. Children are most vulnerable to rapes in India, at least 20,000 cases are reported every year. India has failed to save women and children from rapes. Whether it is city or village of India, the countless other incidents which we get to hear about every now and then, the children are the most vulnerable. Therefore, safety became as one of the important issue for everyone mainly women. Currently, many devices are found in markets which provide protection to women in many forms. Even though there is still a need for a defensive device that protects the victim at time at the time of danger. This provided a new idea of a Bluetooth supporting portable smart band. The woman possessing the band can easily carry it wherever they go. This device will act as an safeguard to the woman who is in danger.

The number of rapes per lakh women has increased from 3.1 lakhs in 2001 to 6.1 lakhs in 2016. NCRB India recorded 24,923 rape cases in 2012. Maneka Gandhi, the minister for women and child development said there was an increase in the rate of sexual offence cases against women an especially child in India. The children rape cases had increased from 8,541 to 12,363 between 2012 and 2013. In 2014, India recorded 13,766 rape cases. In 2015, rape cases were registered as 34,210 all over India. In 2016, India has recorded 106 rape cases per day. The girls between the age-group of 0 to 12 were raped in a large number and in 94.6% of rape cases the offenders were well known to the victims like family members, relatives, neighbors, co-workers etc. Delhi stands first in rape cases at a number 1,996, in Mumbai 712, 354 cases in Pune and 330 cases in Jaipur. NCRB released data that crime rate against women have increased by 2.9% by 2016 all over the country. In case of molestation of women, there is not even a slight decrease in the number of cases reported between 2018-2017, there is only increase in number of rape cases. The offenders were well known to the victim like victim's relatives or even their father.

## II. Related Work

In 2018, Touch me not, proposed by Jismi Thomas, Maneesha KJ, Nambeesan shruti Vijayan, Prof. Divya R, [1] is a button which can be attachable to the clothing. This button will be connected to the system that has two modules, one which can be used when someone makes some sort of unethical movement and the other module which can be used when you sense danger.

Real-time tracking became as one of the most interesting field for many researchers. In 2017 SwaRma – A Women Safety Device, this project was implemented by Anitha.k, Kanimozhi.R, Hemalatha.P, Giridharan.S, [2] which aims to design and develop a Smart GPS Watch with Smart Android App which will track the position of the user and also to monitor all sudden fall and Irregular Attacks. The smart watch tracks the person who wears the smart watch by using an integrated GPS and alerts the authority when that person crosses the virtual zone boundary using GSM and With Android Phone.



In 2017, GPS and GSM based self defense system for women safety, proposed by Sriranjini R, [3] is a device which can be attached to our jacket. There is a push button which can be pressed at the time of emergency. [5][6][10] The main use of this device is to alert the victim's family and friends as well as the police station by sending the location of the user. This system uses a GPS module to track the location of the user and a GSM module to send the alert message along with the location. A speech circuit is used to record a sentence or a phrase previously. This can be used to grab the attention of the surrounding people. This circuit has three buttons namely REC, PLAYE and PLAYL. REC button is used to record a sentence. PLAYE is used to play the recorded sentence continuously. PLAYL is used to play the recorded sentence at number of times the button is pressed.

### III. Proposed System

In this system we are going to propose the new hardware device in the form of a smart band for easy access, instead of the existing software. At any emergency situation people gets panicked and in that situation, they may not be able to operate their Smartphone applications, or immediately defend the attacker to protect themselves. So the user can be able to trigger the device by a single press. We have included the taser for the safety purpose. Taser is a device which produces a small amount of electric shock, which helps the victim to safeguard themselves from the attacker. The user must have to poke the taser on the attacker in order to escape from the bad situation. Our device also sends alert messages with the user's current location using mobile GPS/GSM to the contact numbers already stored using the smart phone application. In this device we are going to include an alarm module. So that the user can use the alarm for safety purpose. When the alarm rings it grabs the attention of the surrounding people to save the person from the attacker. Even if the mobile phone is lost or there is no charge in it, the victim can use the device to escape from that situation.

#### Taser

Taser is a less destructive device used by the police force to keep the potentially dangerous people under their control. The effects of a taser may be a localized pain or muscle contractions. In our system taser is used as a protecting device if in case there is no use in sending location of the victim. Taser works as an immediate helper for the victim to safeguard themselves. It produces only a small amount of electric shock between 2-5 milliamps. This helps the victim to stop the attacker for few minutes. At that time the victim can immediately escape from that place.

#### Arduino Nano Microcontroller

Arduino Nano is a microcontroller which is small in size and is used for embedded systems. It is associated with an USB connection. It is breadboard friendly. It is based on ATmega328. Arduino Nano consists of 14 digital I/O pins of which 6 pins provide PWM output, and 8 analog input pins. It has a flash memory of 32 KB and clock speed is 16 MHz. DC current passing per I/O pin is 40mA.

#### Bluetooth Module

HC-05 Bluetooth module is an Bluetooth Serial Port Protocol (SPP) used for wireless connection setup. This Bluetooth module can be either used in both configurations namely Master/Slave. This module can be configured only by AT Commands. A Master module can initiate connections to other devices whereas a Slave module can only accept the connection but cannot initiate a connection

#### Alarm/Buzzer:

An alarm module is also known as a buzzer or beeper is used as an audio signaling device. In our system we are going to include buzzer in order to produce sound to grab the attention of the surrounding people. This might help the person at danger to seek help from others.

#### Advantages

- This device is small in size, easy to trigger, low power consumption device.
- It is an all-in-one system. Hence no need to carry multiple devices.
- It uses Emergency SOS feature for making emergency calls when mobile signal is lost.
- Real time monitoring of the location.
- The proposed system can be useful for women, children, elders or even physically challenged person for security purpose.

- The person who uses that device will not get affected by it.

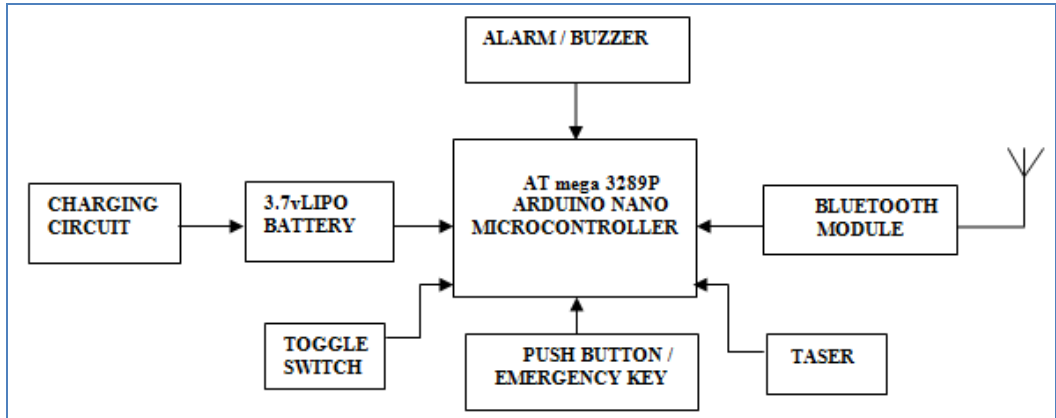

Figure 1: System Architecture

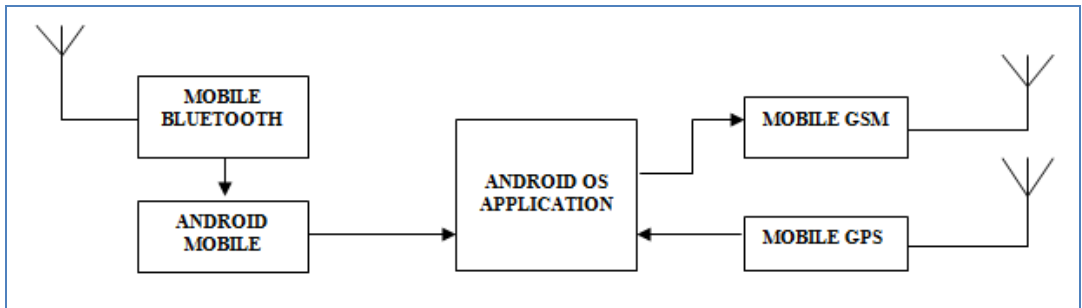

Figure 2: Application Architecture



Figure 3: Data Flow Diagram

Whenever the user press the emergency button, the Bluetooth module in that device connects the smart phone with the device using the mobile Bluetooth and it will access the mobile application that we have developed. The user's current location is tracked and sent to the contact numbers that have been stored already. The mobile application also makes a call to those predefined numbers. After that whenever a person receives a message or a call from the user's device, he can view the current location as well as the address where the user is currently. The user can also receive an acknowledgement.

#### IV. System Modules

This project contains the following modules:

##### Device Modules

##### Taser

Taser is a device which produces a small amount of electric shock, which helps the victim to safeguard themselves from the attacker. The victim has to just poke the taser on the attacker's body so that the attacker might become unconscious or might face difficulty in breathing.

## Alarm

The user can use the alarm for safety purpose. When the alarm rings it grabs the attention of the surrounding people to save the person from the attacker.

## Bluetooth module

The Bluetooth module is used to connect the device with the smart phone application using mobile Bluetooth. If the user press the button on the device it connects with the mobile app and sends the current location of the user to the predefined numbers.

## Application Modules

### Contact update Module

This is used to save the required details of the close one's / Police. The user must just add the details like name and mobile number in the required place and then click on save button for further use.

### Add message

The user can add any alert message in this module so that whenever the user press the emergency button this predefined message will be sent to those contacts.

### Panic button

This module is accessed by the device to send the alert message and to make a call to the saved numbers.

## V. Algorithm Used

The algorithm that we are going to use in our system is Boolean algorithm, where the variables HIGH denotes the device is turned ON and LOW denotes the device is turned OFF. The decision is made by the inputs given as 1 (HIGH) and 0 (LOW). This setup is already programmed into the arduino and when the smart device is turned ON, user's current location is sent to the predefined number using the mobile application.

1. Assign the receiver pin (rx) of the microcontroller as pin number 4.
2. Now set the rate of the serial buffer as 9600 bits per second.
3. Then set a loop to trigger the following :
  - a) Get location data using the mobile GPS.
  - b) Convert the latitude and longitude coordinates which have been obtained using mobile GPS into an URL.
  - c) Now the URL is attached with an alert message which is predefined.
  - d) This message is sent to the contact numbers periodically.

## VI. Conclusion and Future Work

This project would help in increasing the safety and security of people belonging to different age groups. The use of this device might reduce the rate of crimes against the women largely. The device is an all-in-one system and is small in size so there will be no need to carry multiple devices. We also developed a mobile application in order to prevent some kind of emergency situation, to alert the close ones by tracking the location of the victim to stop such type of illegal activities.

Our project can be enhanced by adding more features like camera module for live recording, and sensors to automatically turn the device ON, to easily detect the emergency situation faced by the victim. The device can be made even smaller in future for operating easily. Also a mobile application for tracking the location of the user using virtual 3D map can be implemented. This helps to easily find the victim's location.

## References

1. Touch Me Not - A Women Safety Device, Jismi Thomas, Maneesha K J, Nambissan Shruthi Vijayan, Prof. Divya R, 2018.
2. SwaRma - A Women Safety Device, Anitha.k, Kanimozhi.R, Hemalatha.P, Giridharan.S4, 2017.
3. GPS and GSM Based Self Defense System for Women Safety, July 2017.
4. IoT Based Child and Woman Safety Mahejabeen Budebhai VLSI Design & Embedded Systems, VTU Belagavi, State Karnataka, India, August 2018.

5. Design and Implementation of a Rescue System for the Safety of Women by using Arduino Controller, 2018 IJARIT R. Pavithra ,P. S. Sangeetha ,M. Shakthi Devi ,S. Vanila.
6. A Safety Device for Women's Security Using GSM/GPS Miss. Ashwini .P. Thaware, April 2017.
7. A.P. Thaware, "Safety device for women's security using GSM/GPS", International Journal on Recent and innovation trends in computing and communication, vol.5, issue.4,5-7, 2017.
8. DivyaChitkara, Nipun Sachdeva ; Yash Dev Vashisht, "Design of a women safety device", 2017 IEEE.
9. Intelligent Safety & Location Tracking Device for Old Age & Women Using Concept of "Internet of Things" 2016 ,Prof. Nitin S.Wagh, Prof. Ravindra P. Shelkikar.
10. Gowri Predeba B, Shyamala. N, Tamilselvi.E, Ramalakshmi.S, Selsiaulvina. "WOMEN SECURITY SYSTEM USING GPS AND GSM", (IJARTET), April 2016.

---

# EFFICIENT TESTING OF WEB APPLICATIONS USING ACTION BASED KEYWORDS

Mrs. R Adline Freeda, Mrs. Krithikaa Venket, Mr. N Bhaskar

Department of Information Technology,  
KCG College of Technology,  
Chennai, India

---

**ABSTRACT:** Programming advancement organizations depend profoundly on Automation testing and embrace different mechanized testing structures. There is a need to build up a testing structure which ought to be application autonomous and versatile. Action based Keyword Driven testing is the answer for previously mentioned issues. The thought behind the Action based Keyword Driven methodology in computerization is to isolate the coding from the experiment, test step and driver content. Action based keyword driven test mechanization system improves reusability of computerized test contents. Action based KDT structure suite enables manual analyzers to take part in the robotized test creation with no programming learning. It additionally decreases the general upkeep cost. The proposed system utilizes Web Driver API for testing web applications. The experiment results are produced as HTML-based reports.

**Keywords:** buffering systems; distant monitoring; network connectivity.

---

## 1. Introduction

Programming Development Life Cycle characterizes (SDLC) the stages in structure of programming. SDLC comprises of different stages. Testing is one of the last stages before the sending of programming/item. Programming testing is a procedure of executing a program or application with the aim of finding the product bugs. It can likewise be expressed as the way toward approving and checking that a programming system or application or item (a) Meets the business and specialized prerequisites that guided it's plan and improvement (b) Works as expected (c) Can be executed with a similar trademark. Programming testing should be possible in two ways. They are manual trying and Automation testing. Prior, Software testing was done physically by analyzers. Manual testing requires increasingly human work and furthermore tedious undertaking. Mechanizing the testing procedure defeats the entanglements of manual testing. Computerization testing alludes to utilizing exceptionally planned programming to test programming. Programming improvement organizations depend exceedingly on mechanized testing and embrace different computerized testing structures. The different mechanization testing systems accessible are Modular trying structure, Data driven testing structure, Keyword driven testing structure.

## 2. Related Work

The Authors Ajeet Kumar, Chandrababha, Sajal Saxena [2] in the paper [2] have clarified about Data driven testing system what's more, how it very well may be actualized for testing web applications. The principle impediment of this system is it is application dependent. The experiments and the driver contents are emphatically related, which prompts changing possibly one requires changing the other. Experiments made are comparative and making new sort of tests requires making new driver contents that comprehends unique information. In Data driven testing, it requires incredible ability of scripting language, and furthermore countless records for each test case with numerous sources of info. Accordingly by surmising, Action based Keyword Driven testing is the answer for previously mentioned issues, which is application autonomous and versatile. The thought behind the Action based Keyword Driven methodology in computerization is to isolate the coding from the experiment, test step and driver script [1][3].The creators Abhishek Jain, Sheetal Sharma [1] described how create catchphrases and portrays how experiments can be planned and executed with the assistance of watchword driven test computerization system. The authors [3] have expressed the watchword driven system approach with a precedent. [3].

## 3. Overview of study

The authors Ajeet Kumar, Chandrababha, Sajal Saxena in the paper [3] have explained about Data driven testing framework and how it can be implemented for testing web applications. The main disadvantage of this technique is it is application dependent .The test cases and the driver scripts are strongly related, which

leads to changing either one requires changing the other. Test cases created are similar and creating new kind of tests requires creating new driver scripts that un-derstands different data. In Data driven testing, it requires great expertise of scripting language, and also a large number of data files for each test case with many inputs. Thus by inferring, Action based Keyword Driven testing is the solution for above mentioned problems, which is application independent and scalable. The idea behind the Action based Keyword Driven approach in automation is to separate the coding from the test case, test step & driver script [4]. The authors Abhishek Jain, Sheetal Sharma [4] described how develop keywords and describe how test cases can be designed and implemented with the help of keyword driven test automation framework. The authors [4] have stated the keyword driven framework approach with an example. [4]. Thus by inferring from the literature analysis, Action based Keyword Driven testing is more efficient than the other two types of testing namely Modular and Data Driven. Keyword driven test doesn't require much of technical expertise to execute the test. The Test data is read from an external file like Excel sheet etc. The proposed action based keyword driven framework will be coded in VB Script and will be executed in UFT.

**4. Proposed Methodology**

Action based keyword driven testing system chooses the keywords for test cases dependent on the activities performed. An excel expectations sheet is made to store the test subtleties. It contains the test suite id, testcase id, the application URL which is going to be tried, page, object name, locator type, locator esteem, keyword and information. Every keyword will be related with a fitting capacity what's more, information UFT Automation Tool is utilized for the execution of Test cases. The driver content sorts out the test execution and furthermore stores test signs in determined envelope/document. A test case contains the test steps and test steps are utilized to recognize the keywords. Microsoft Access is utilized as the database. It stores all the test related information in table arrangement. The information in excel expectations will be refreshed in MS Access database consistently.

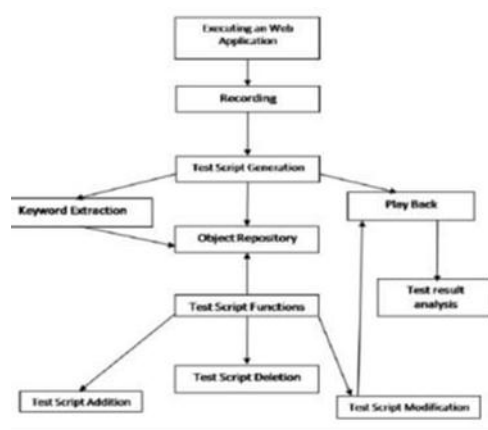

Fig 1: Framework Workflow

The workflow delineates the work process of the Keyword driven structure proposed in the paper. Initial a web application is taken which is should have been tried. To begin the procedures of account enter the URL of the ideal web application. As the client explores the web application catchphrase driven testing structure records the means. This task frames the premise of the test.

The device records every one of the activities performed in the internet browser until the chronicle is ceased when the account is halted, the test content document is produced. This produced test content record containing all the client activities is spared. The test content will be helpful in the playback of the test and reusability of the test content. At the point when the test is play upheld, the device runs the spared test content record. The recorded web application opens in the internet browser and different advances are performed consequently as it was initially recorded in the test. At the point when the trial is finished, it shows the consequences of the keep running in the test outcome page. The test outcomes window shows the key components of the test accomplished for test investigation reason. The key components are made out of two sections first component demonstrates the means that were performed while the test was running. The second component is the test outcome subtleties. The test outcome contains cycles and status outline. Item

archive is a brought together spot for putting away the properties of articles accessible in application under test. The catchphrases can be included the item archive at the season of account. All product applications and sites are created utilizing various segments or little units. At last the test outcome examination is created. The authors of [1,2] conclude by asserting keyword driven framework is efficient by explaining about the different types of keywords, requirements, object repository and keyword driven modules are investigated. These are required to carry out a successful and efficient operation of keyword driven testing.

#### 4.1 Framework elements

Action based keyword driven system is an application-free structure that plays out every conceivable activity and checks on an article. Subsequently, the code for a similar item can be utilized crosswise over various applications. Action based keyword driven Framework comprises of following parts.

#### Web Application or AUT:

The web application or site page on which test must be performed. The URL of the web application is utilized to distinguish web page.

#### Driver Script:

The Script that drives the whole execution. It performs essential and beginning settings that are required for the execution. The driver content composes the test execution and furthermore stores test signs in determined record.

#### Test Cases:

A testcase is a lot of conditions or factors under which an analyzer will decide if a framework under test fulfills pre-requisites or works effectively. The Test Case contains four unique parts. They are Test Step, Object of Test Step, and

#### Activity on Test Object, and Data for Test Object.

- 1) Test Step : Description of the Action going to perform on Test Object
- 2) Test Object: Name of the Web Page or component, as Username and Password.
- 3) Action: It is the catchphrase which will perform activity on any article, for example, click, open program.
- 4) Test Data: Data is the esteem required by Object to play out any activity, as Username esteem for Username field.

In keyword driven test structure, every one of the activities and guidelines are written in some outside document like Excel worksheet.

### 5. Sequence Diagram

A sequence Diagram is a connection chart that indicates how questions work with each other and in what request. It is a develop of a message succession graph. A grouping chart indicates object communications orchestrated in time arrangement. It portrays the articles and classes associated with the situation and the grouping of messages traded between the items expected to complete the usefulness of the situation. Sequence Diagram outlines are ordinarily connected with use case acknowledge in the Logical View of the framework a work in progress.

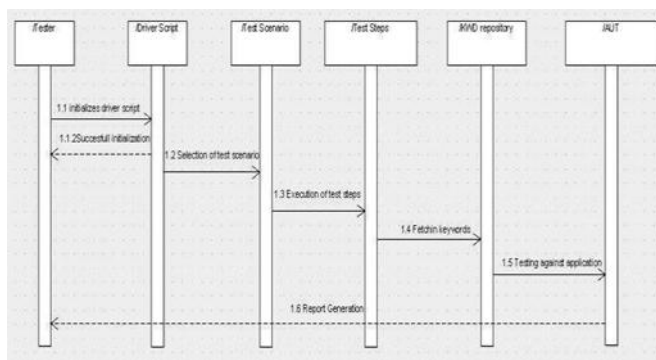



Fig. 2. Sequence Diagram

Sequence diagram for Action based Keyword Driven Frame-work is explained as follows,

- The Tester initializes the driver script. Driver scripts play a main role in testing
- Driver Scripts then selects a test case scenario to be executed
- Once test case scenario has been selected, the test steps in that particular test case will be executed.
- Keywords are fetched from the test steps during the execution of test steps.
- The functions which are associated with each keyword is also fetched along with the keywords
- The fetched keywords and their functions are tested against the application which is under test
- The test driver script will generate the report for test case which was executed.
- Whether the test passes or fails, Test execution will be stopped after report generation.

## 6. Implementation

The Action based keyword driven test makes script maintenance easier. The keyword driven test does not only separate out the testing data from the script, it also separates out the data handling logic by encapsulating the testing operation into keywords. For each keyword, testing step descriptions and specific implementation details are separated. The testing step implementation is encapsulated into the keyword, and the keyword name explains what function the keyword performs. Therefore when the tester creates the test case, the various keywords from the keyword database can be used and not need to think about the implementation details of the test steps. The test script is built up by various keywords. One keyword may be contained in different test scripts. The same test script can generate different test cases by binding different test data. By using the keyword driven test, the test script is separated into many independent parts. Each part can be maintained and specific implementation details are separated. The testing step implementation is encapsulated into the keyword, and the keyword name explains what function the keyword performs. Therefore when the tester creates the test case, the various keywords from the keyword database can be used and not need to think about the implementation details of the test steps. The test script is built up by various keywords. One keyword may be contained in different test scripts. The same test script can generate different test cases by binding different test data. By using the keyword driven test, the test script is separated into many independent parts. Each part can be maintained separately without affecting the others. Thus the reusability and maintainability of the test scripts is improved.

The Components of action based keyword driven automa-tion framework are mentioned below.

1. Excel Sheet to Store the Keywords: Once you have identified the required keywords, you can store them in an excel sheet. It does not need to write some code that will first open this excel sheet and copy the keywords. Based on the keyword, QTP will call the function associated with it.
2. Function Library: In Action based Keyword Driven Framework, function libraries plays a very important role

Function library can read the excel sheets and call the different functions based on the Keywords.

Data Sheets: Data sheets can be used to store the test data that will be used in the application.

1. Object Repository: Object Repository is a centralized place for storing properties of objects available in Application under Test (AUT). Objects such as textbox control, input tag, web browser control etc. These components or small unit are known as Objects. Each object will be identified based on the object type. Each object will also have its own properties like name, title, caption, color, size. These properties help in the identification of these objects uniquely. There are also specified set of methods for each object.
2. Driver Scripts: Driver script is the single main script of the Driver Engine. It iteratively traverses through the data of business scenario flow and calls the respective reusable scripts sequentially. It contains test case scenarios and test steps. This is the main method and starting point for the framework code. The main responsibilities of this method are given below.

- Read the test case steps from the datasheet one row at a time
- Execute the method corresponding to the current step in the test case.

3. Test Data Sheet: The test data sheet is the main user interface tester interacts with. The driver in initialized through the execution of teat case .The data sheet contains below columns.

ID -Manual test case ID

Test\_Case\_Name - Name of the testcase Test\_Step\_Id - Step Id of the Testcase Test\_Case\_Steps - Step name of the testcase

Keyword - The name of method in function library you want to call.

Object Types - type of the web elements like web edit, web list, web check box etc

object Names - Web element identification method and expression likexpath://td

Object Values - actual test data you want to enter in the web Element

parameter1 - extra parameter to drive the method control parameter2 - one more parameter to drive the method control.

Unified Functional testing tool is an automation tool used to test web application. The driver script for UFT is coded in Vbscripts and the driver script is responsible for execution of test cases. Microsoft Excel is a spreadsheet developed by Microsoft. Excel sheet is used for representing the test case and related data. Excel contains four sheets. They are Object repository, test data, test lab and test result. A data sheet contains the input data to be given to AUT. Object repository contains the objects that are present in the web application. Objects are the elements in web application like text box, button, radio button, list etc. These objects are manually captured using the UFT object repository manager. The test lab contains the results of test scenario. Test result sheet contains test results of individual objects of test scenario. Framework driver script read the excel file and execute all the test steps which are embedded in the excel file. Once "Execute test" in test lab is selected in excel, the execution starts automatically. Excel automatically invokes UFT tool. The invoked Driver Script in UFT tool connects to the access database and executes the initialize function. The figure 3 depicts how the driver script execution begins in UFT Tool. The UFT performs test on the web application using driver script connecting to the test steps and inputs the test data from excel to web application. After the execution tests, test results will be generated in test result sheet. The test case, test step and driver script are independent of each other. The driver script contains keyword functions that can be reused for testing web applications.

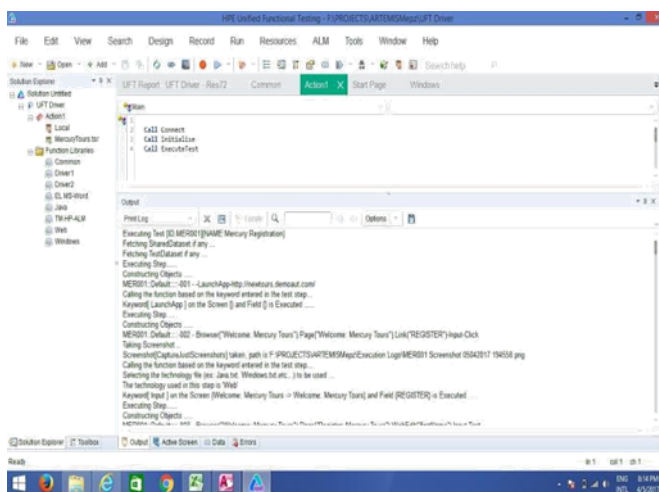

**Fig. 3. Driver Script execution**

Referring Figure 4 depicts test case result for the executed test on a module in application under test (mercury tours). The advantages of using this method are listed below. In the keyword driven test, the amount of scripts varies with the testing scale, but not with the number of test cases. The number of test cases can be increased by using different keywords instead of adding more testing codes. The keyword driven test reduces the cost of script maintenance and speeds up the test case implementation.

Test Case ID	Test Case Name	Test Case Description	Test Case Status	Test Case Priority
TC001	Verify User Login	Verify that a user can successfully login with valid credentials.	Pass	High
TC002	Verify User Registration	Verify that a user can successfully register with a valid email and password.	Pass	High
TC003	Verify User Logout	Verify that a user can successfully logout from the application.	Pass	Medium
TC004	Verify User Profile Update	Verify that a user can successfully update their profile information.	Pass	Medium
TC005	Verify User Password Reset	Verify that a user can successfully reset their password.	Pass	Medium
TC006	Verify User Search Functionality	Verify that a user can successfully search for products.	Pass	Medium
TC007	Verify User Cart Functionality	Verify that a user can successfully add items to their cart.	Pass	Medium
TC008	Verify User Checkout Functionality	Verify that a user can successfully complete a purchase.	Pass	High
TC009	Verify User Account Deletion	Verify that a user can successfully delete their account.	Pass	Medium
TC010	Verify User Account Recovery	Verify that a user can successfully recover their account.	Pass	Medium

**Figure 4 Test case report**

The keyword driven test provides an extra layer between the testing code structure and implementation. When the testing tool or platform is changed, the tester does not need to change the testing script design but only needs to rewrite the code for keyword implementation. The tester can create a new test case by just using the existing keywords. It reduces the programming skill requirements of the tester. A tester who does not know testing script implementation can still perform function testing. The keyword driven test separates the testing data, testing logic and the testing script. With this testing approach, the modification and implementation of test cases becomes easier. The tester can modify a test case by replacing some keywords or changing the existing keyword script. It makes the testing script structure clearer and improves its reusability.

## 7. Outcome and Discussions

The outcome of this proposed system would be an automation framework which can be used to test web applications. Since the test data, test steps and driver script are independent of each other, it makes the framework to be reusable across various web applications for testing. The proposed framework will test web application automatically when tester initializes driver script. Human intervention is not required in between execution. Once the test execution is over, test report will be generated based on testing web applications. The test report contains web page name its element and the test result. Test result will be represented by PASS or FAIL as in Figure 6. Pass represents that the web page and it elements satisfies its requirement and functions properly. Fail represents the web page and elements malfunctions. This final report can be used to correct the faults and also can benefit business strategy. The GUI testing can be done in minimized cost and reduced time with proposed framework.

## 8. Conclusion and Future Enhancements

Software testing is the method of testing application in order to find the variation between the output and the actual output. Automated testing does not required much human effort as the testing of application is performed with the help of other application but it is a tedious job as we need to test the application again and again for every small change in the application. To overcome with these problems, Action based Keyword Driven Framework is proposed. Here a excel workbook which contains all the keywords is used for which the functions or methods are created in the Framework script file. The proposed framework does not require the knowledge of programming language for testing web application as all the code is already embedded in Framework script file. This framework is application independent since test data ad scripts are independent of each other. Moreover there is no need to alter the code to test different applications and only the excel workbook is changed which is very easy. The experimental results prove that the framework is cost efficient and very easy to use. This Framework could be made versatile by adding more features like automated email reminder when test cases are finished, automated screenshot generation of the failed test cases.

## References

1. Abhishek Jain, Sheetal Sharma "An Efficient Keyword Driven Test Automation Framework for Web Applications". International Journal of Advance Research in Science and Engineering Volume-2, Issue-3
2. Ajeet Kumar, Chandraprabha, Sajal Saxena "Data Driven Testing Framework using Selenium Web Driver". International Journal of Computer Applications Volume 118 – No. 18, May 2015

3. Rashmi, Neha Bajpai "A Keyword Driven Framework for Testing Web Applications". International Journal of Advanced Computer Science and Applications, Vol. 3, No. 3, 2012
4. G. A. Di Lucca, A. Fasolino, F. Faralli, and U. D. Carlini. "Testing web applications" in International Conference on Software Maintenance, 2002.
5. Laukkanen, Pekka, "Data-Driven and Keyword-Driven Test Automation Frameworks", Master's Thesis, Software Business and Engineering Institute, Department of Computer Science and Engineering, Helsinki University of Technology, 2006.
6. Edward Kit, "Integrated, Effective Test Design and Automation", February 1999.
7. Burnstein, Ilene, Practical Software Testing: a process-oriented approach. 709, Springer, New York, 2003.
8. Pettichord, "Seven steps to test automation success" in Proceedings of the Software Testing, Analysis & Review Conference (STAR), 1999.
9. R Mugridge & W Cunningham, "Fit for Developing Software: Framework for Integrated Tests", Prentice Hall PTR, 2005.
10. Hamill, Unit Test Frameworks, O'Reilly Publications, 2004.
11. Pajunen, T.; Takala, T.; Katara, M. "Model-Based Testing with a General Purpose Keyword-Driven Test Automation Framework" in Software Testing, Verification and Validation Workshops (ICSTW) on page no. 242-251, 2011.
12. Craig and S. Jaskiel. Systematic Software Testing. Artech House Publishers, 2002.
13. M. Grindal, J. Offutt, and S. F. Andler "Combination Testing Strategies: a Survey", Software Testing, Verification and Reliability, Vol. 15, No. 3, pp. 167-199., 2005.
14. I. Pinkster and Buwalda, D. Janssen, "Integrated Test Design and Automation: Using the Test frame Method". Addison-Wesley, 2002.
15. B. Pettichord and Kaner, J. Bach, "Lessons Learned in Software Testing: A Context-Driven Approach", John Wiley & Sons, Inc., 2001.
16. Michael Kelly, "Choose a test automation framework", QA, Liberty Mutual, Web URL: <http://www.ibm.com/developerworks/rational/library/591.html> , 20 Nov 2003
17. B Liskov, "A Framework for Automated System Testing", WebURL: "[dspace.mit.edu/bitstream/handle/1721.1/40188/35334586.pdf](http://dspace.mit.edu/bitstream/handle/1721.1/40188/35334586.pdf)", 1996
18. B. Posey and Mosley, "Just Enough Software Test Automation", Prentice Hall PTR, 2002

## Implementation of Fleet Management System using Wireless OBD II

Ms AishwaryaJeggan, Ms Akshaya N, Ms Myuri N, Mr KPK Devan

Department of Computer Science and Engineering,  
Easwari Engineering College,  
Chennai, India

**ABSTRACT:** Majority of vehicles consist of Engine Control Unit. It is general that the vehicle's status is monitored and diagnosed by technicians through the Engine Control Unit. Diagnostics can be classified into two types: On-Board Diagnostics and Off - Board Diagnostics. This project aims to provide an interface for individuals to check their car's status periodically through On - Board Diagnosis. The vehicle dynamic parameters are uploaded to the user's cloud storage for analysis and future reference. On-Board Diagnostics port collects the control information from the Engine Control Unit and transfers it to the user's application. In addition to this, this project also aims to provide fuel consumption ratio between the actual and expected consumption. Implementation of this system provides the user to analyze their vehicle without the help of a technician.

**Keywords:** Engine Control Unit, On - Board Diagnosis, Bluetooth, Cloud Storage

### 1. Introduction

Murphy's law states " if something can go wrong, it definitely will ". This law is especially applicable to every machine that runs on motors. Whenever there is a fault in the vehicle, it is sent to the mechanic shop for fault identification and repair. The fault identification is the hideous process that is further made easier with the introduction to the vehicle diagnostics. The state of performance of the subsystems, sensors and the actuators are scrutinized in a typical vehicle diagnostics. The vehicle diagnostics can be divided into two types, off-board diagnostics and onboard diagnostics. The off-board diagnostics toe the line for every other parameter from ECU other than emission. The Unified Diagnostics Services (UDS) protocol is used as the most popular diagnostic tool for the off-diagnostics. The UDS stores every fault in the vehicle as the Diagnostic Trouble Codes (DTC). The status and the parameter that is diagnosed divaricate accordingly when the vehicle is either idle or in motion. The off-board diagnostics takes an offbeat from onboard diagnostics in the reporting part. The onboard diagnostic reports by using a red light indicator whenever there is a blunder. Whereas the off-board diagnostics report these codes only when the vehicle is tested by the technician. There is no instant report in case of off-board diagnostics. These codes are hoarded in the EEPROM part of the vehicle ECU. These codes are retrieved using the vehicle testing tool at the service garage. It is not only used to report the trouble codes but also used for ECU reprogramming, remote routine activation and to write data on the automotive Electronic Control Unit and even more. The On Board Diagnostics are used extensively for the repairing purposes instead of off-board diagnostics due to its reporting issues. The On-Board Diagnostic System (OBD-II) is a standard which was developed in 1996, by Society of Automotive Engineers (SAE) in United States of America. This standard has been made compulsory in every light weight vehicles in 1996, followed by medium weight vehicles in 2005 and heavy weight vehicles also made mandatory after 2010.

There are several Diagnostic Standards including OTX, ODX, OBD, and UDS. Open Test sequence eXchange (OTX) is an exchange format, standardized in ISO 13209, for befittingly describing automated diagnostic sequences such as system tests or guided debugging. OTX is in significance to automotive Original Equipment Manufacturer (OEM's) and suppliers in the domains of development, production, and service. The diagnostic sequences are based on XML and can be exchanged between process allies with diverse platforms and demonstrative checkers. This makes it accessible to reuse and prolong sequences. In turn, this enhances potency and encourages long-term availability of diagnostic data. Since 2001, Vector is contributing to representing the Open Diagnostic Data Exchange (ODX) standard in the Association For Standardization Of Automation And Measuring (ASAM) and International Organization for Standardization (ISO) working committees. ODX is now published authoritatively as ISO 22901-1:2008. Certain automotive OEMs and suppliers are already blending ODX into their construction methods. The ODX Composition represents onboard diagnostic functions and protocols in a regulated custom. The XML-based data representation format permits vehicle manufacturers and their suppliers to manage all data of the vehicle life cycle, i.e., development, production, and service data, in a consistent way .Overall vehicle diagnostics

demands confined cooperation between ECU and service diagnostics development. When off-board diagnostic functions are developed in correspondence to the ECU software, they can be experimented at an immature form of construction. INCA promotes ECU diagnostics and flash programming docile to the OBD and ODX standards. INCA is a measurement, calibration and diagnostic software distributed by ETAS. With its extensive foundation base in the auto industry, this development software is stationed during all phases of the development of electronic control units (ECUs) and ECU software programs for measuring, calibration, diagnostics, and programming. Being able to perform software functions and sequences of service inspectors, INCA grants for the validation of service diagnostics before service tester hardware is accessible.

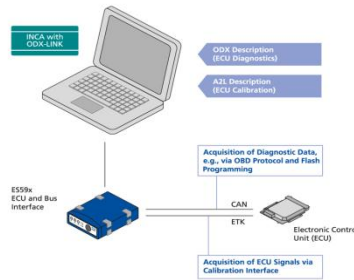

Fig 1. With ODX-LINK, INCA presents an entire ODX-based solution for validating vehicle diagnostics

Onboard vehicle diagnostics (OBD2) get involved when the vehicle is moving. The experiments are administered while the vehicle is in motion. The experiment results can be noticed on the vehicle's dashboard in the form of MIL (Malfunction indicator light) or an OBD tester tool. The results that OBD makes available is linked to:

- Emission Control System
- Engine and transmission ECU's (power train)

Every parameter associated to the vehicle discharge such as information from oxygen sensors and the fuel injectors etc. is checked. In case of any breakdown, an MIL (malfunction indicator light) is triggered to notify the vehicle owner. Additionally, a resilient home mode may be stimulated in some high-end cars. This mode actuates an algorithm to let you drive home or to the service garage without provoking more blow to the vehicle. The failure that triggers the MIL is also saved in the automotive ECU which can later be reclaimed by the tester tool at the carport. This fault code assists the professionals to point the emission issue and amend it.

Every vehicle has its own Engine Control Unit (ECU). It is a module used to monitor the series of sensors and actuators that collects the real time parameter readings. Most recent motors use some type of fuel injection to pass fuel to the cylinders. The ECU defines the amount of fuel to inject based on sensor readings. Oxygen sensors indicate the ECU whether the engine is in good condition (too much fuel or too little oxygen) or running low (too much oxygen or too little fuel) as compared to prototypical conditions (known as stoichiometric). The throttle position sensors tell the ECU how far the throttle plate is unlocked when you push the accelerator. The mass air flow sensor measures the amount of air passing into the engine through the throttle plate. The engine coolant temperature sensor computes whether the engine is warmed up or cool. If the engine is still cool, fuel is added into the engine.



Fig 2. Engine Control Unit (ECU)



The ECU is connected to the On - Board Diagnostics through CAN bus. The Controller Area Network (CAN) bus is a standard that involves in the data transmission from the ECU to any parts of the vehicle. It acts as the multi - master serial bus that transmits data. The CAN bus is low-cost, robust and message based. It was originally developed by Robert Bosch in 1986. The efficiency of the CAN bus depends on the high and low speed of the CAN. The speed of the CAN depends on length and capacitance of the data cable.

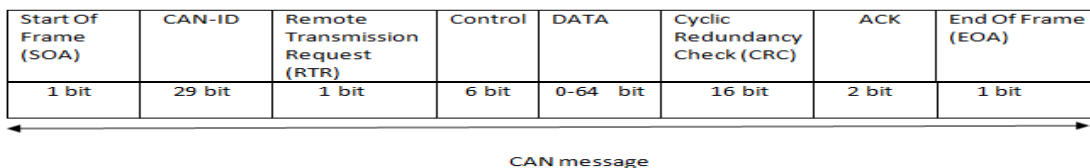

Fig.3 CAN message

The CAN bus transmits the data in the form of hex code. These codes are received in two forms, namely, Parameter Identifiers (PID) and Diagnostics Trouble Code (DTC). The Parameter Identifiers are the codes requested by the OBD - II, used as a diagnostic tool. The PID's return the current condition of the vehicle during a request from the OBD - II, unlike DTC that gives out the codes only during the trouble time. There are 4 bytes in standard PID, each bit is numerated from 0 to 7. The code 01 signifies the service which is normally used during the data request from the ECU. There are several hex codes in PID that identifies every parameter uniquely. It is necessary to be accessed by a standardized data link connector defined by SAE J1962. This document is intended to satisfy the requirements of the OBD connector in USA. The document SAE J1979 has been compiled to satisfy the data reporting requirements of OBD - II. According to SAE J1979, there are ten diagnostic services in OBD - II. The service of the hex code is given in table 1.

Table 1: Service Code Description

Service (Hex Code)	Description
01	Show current data
02	Show freeze frame data
03	Show stored Diagnostic Trouble Codes
04	Clear Diagnostic Trouble Codes and store values
05	Test results, Oxygen sensor monitoring

The DTCs are used in the automobile industry to identify the troubles that is causing the vehicle. These codes are framed only if any fault found in the vehicle by the ECU.

The DTC consists of 5 digits, each digit indicating the status of the vehicle.



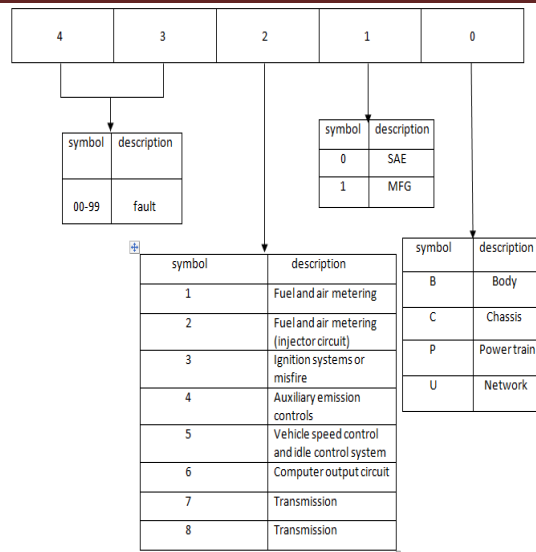

Fig 4. Diagnostic Trouble Codes indicating the status of the vehicle in each bit of PSW

The data from OBD - II is then transmitted to the nearby device using wireless technology. The bluetooth technology is used for the communication of data over short distances. It uses UHF radio waves in the ISM band from 2.4 to 2.485 GHz including guard bands 2 MHz wide at the bottom end and 3.5 MHz wide at the top. This is in the globally unlicensed industrial, scientific and medical (ISM) 2.4 GHz short-range radio frequency band. Bluetooth employs a radio technology termed as frequency-hopping spread spectrum. Bluetooth segments transmitted data into packets, and forwards each packet on one of 79 assigned Bluetooth channels. Every channel has a bandwidth of 1 MHz. It habitually performs 1600 hops per second, with adaptive frequency-hopping (AFH) approved. Previously, the OBD - II uses RS232 data cable for its transfer of hex codes. RS232 is one of the widely used techniques to interface external devices with computers. RS232 is a Serial Communication Standard extended by the Electronic Industry Association (EIA) and Telecommunications Industry Association (TIA). This technology has been replaced by the bluetooth. RS232 cable can connect the OBD-II to the computer for the data transmission whereas the bluetooth is used to maintain the wireless communication with any mobile devices to the OBD-II.

## II. Related Works

The advancement of technology in the field of networks make communication simple between devices. With improved versions of hardware and technology, portable devices such as mobile phones, laptops have become powerful with high computation potential. Mobile devices have gained a significant advantage with research and development in the field of communication which lead to its increased usage. Javier E. Meseguer, et al [1] proposed a system which deals with eco-driving based on driving characteristics. The greenhouse gas emission from the vehicles is related to fuel usage. It can be said that the greenhouse gas emission depends on fuel consumption. Usage of fuel in an efficient manner will reduce the greenhouse gas emission. Driving style of the user brings a variation in fuel consumption and hence the pattern was identified using Neural Networks. Efficient driving styles can achieve fuel savings ranging from 15 to 20%. The study in [2] presents a cloud-based data acquisition and analytics system to monitor real-time driver behaviour. The system collects, stores and analyses the information acquired from the vehicle for a long period of time through OBD-II. The data collected is sent to the cloud servers via 3G/4G connection. The system uses ELM327 adapter to transmit the data read via Bluetooth. The OBD-II Parameter IDs (PIDs) is used to acquire information related to the vehicular condition. This system used a real-time data processor based on WSO2 Siddhi. The required information alone is stored in the cloud. An alert message is sent for simple cases and for complex cases a filtered stream is sent to the backend server. On the occurrence of unsafe events the Complex Event Processor (CEP) detects and notifies the user. This system is mainly implemented to alert reckless driving pattern and driving anomalies. The drawback is that, if the driver do not allow data transmission the proposed system will not be useful. This can be overcome by designing a dedicated hardware which is still in further research.

Whenever a vehicle starts to dissipate air pollutants the OBD - II initiates the DTC and notifies the car owner in order to schedule maintenance. The technicians had to undergo a tiresome approach to diagnose and to detect the malfunction. The paper [3] basically designs a circuit system which enables a real - time surveillance in order to avoid the unnecessary wait. The circuit converts the OBD information from J1962 standard to RS232 protocol. This system combines GPRS, GPS and GIS also known as G<sup>3</sup> technology in order to establish a communication medium for the surveillance. It also incorporated Advanced RISC Machine (ARM) embedded system using  $\mu$ CLinux operation in the client - server architecture to connect them.

The most important criteria for any vehicle is its overall safety. Whenever an equipment fails in a predictable manner, the functional safety of the vehicle is taken into consideration. The potential risk of failing in functional safety can lead to short circuit, increased noise pollution and vibration resulting in an ultimate deterioration in the performance. The study in paper [4] developed a systematic model based diagnostic approach based on structural analysis for electric drive system that can form the basis of OBD design for Electric Vehicles and Hybrid Electric Vehicles (EV/HEV) for their functional safety. It is developed in agreement with safety standards. A systematic fault detection and isolation (FDI) methodology is presented which is pertinent to any automobiles in general. An electric drive system is coupled with various sensors to diagnose the fault. Structural analysis is a model based method that uses a structural model of the particular system to identify the ARR (Analytic Redundant Relation) of the system that helps to find the faults. It easily evaluates the fault by going through the system's structure in graphical or matrixform. This provides a general framework to analyze and design failure modes. This method was validated through both simulation and experimental study and the combined results proved the effectiveness of the proposed system.

With the introduction of OBD - II, there has been several developments in the automobile industry regarding the performance efficiency. Reza Malekian, et al [5] has intended to measure the fuel consumption and location tracking of the vehicle in this paper. The speed and the Mass Air Flow (MAF) can be measured in order to compute the distance that the vehicle has travelled and the fuel consumption. This system has been implemented to achieve the efficiency in vehicle operational performance, increase in quality of service and for risk management at minimal cost. This project exploits OBD - II, Wi-Fi and GPS technologies to measure the parameters. This paper deploys CAN protocol and carambola2 module extensively. The CAN protocol report the states of the signals that is transmitted in ECU on the bus. The Carambola2 Wi-Fi technology implementation involves the AP mode and STA mode configuration for the effective wireless connection purposes. This paper has achieved vehicle parameter over short and long distance for the fuel consumption. It is found that when the engine is turned off, the connection between the wireless modules has been turned off too. The parameter measurement of the vehicle performance exhibited an error of 5% approximately.

### III. System Overview

Figure 5 shows the detailed functions of the proposed system. The ECU present in the vehicle performs the data acquisition required for the vehicle dynamics calculation.

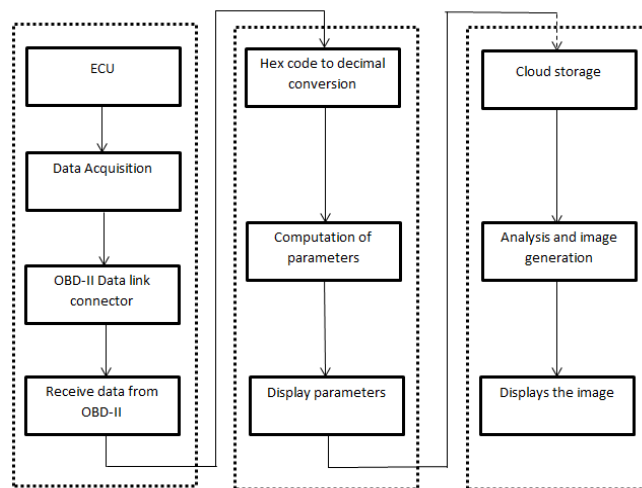

Fig 5. Functional architecture of the proposed system

The acquired data is transmitted to an OBD-II reader which is connected by a standard connector present in the vehicle. The data from the ECU is detected and interpreted according to the OBD-II protocol. Since the acquired data will be in hex code, it is converted to decimal code in the Android application developed which is used for further calculations. After the conversion, the required parameters are computed by substituting in the respective equation. The computed parameters are displayed and then sent to the user's cloud storage. These data are stored for a period of time which is then analyzed for monitoring the vehicle condition. The output of the analysis is displayed in a graphical format.

#### IV. System Design

A basic overview of the proposed system is given in figure 2. It consists of three subsystems namely, 1. ECU and OBD communication unit, 2. Processing unit, 3. Data visualization and storage.

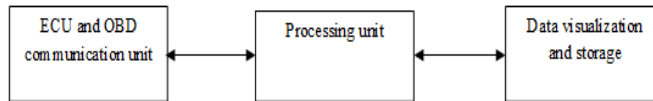

Fig 6. Overview of the proposed system consisting of three subsystems

##### 4.1 ECU and OBD communication unit

ECU is a type of Electronic Control Unit. It controls a series of actuators. The actuators work on an internal combustion engine to ensure optimal engine performance. The OBD-II communicates with the ECU via CAN bus (Controller Area Network). CAN is a standard that allows microcontrollers and devices to communicate with each other. It is generally a message based protocol that allows communication with OBD-II. The OBD-II sends a request message to the ECU and the ECU replies back with response message to the OBD-II. Both request message and response message are in the form of hexadecimal code. The hexadecimal code consists of a 11 bit identifier and a 64 bit data section. Structure of the hexadecimal code is given in figure 2. The data section has three fields namely mode, PID and databytes. The databyte section further has four fields which is given as Ah, Bh, Ch and Dh.



Fig 7. Structure of the message received from the ECU

The 64 bit data has four fields where the first field is mode. It represents the request and response of messages. The field holds any value ranging from 01 to 0A for request message. The values ranging from 41 to 4A represents the response message.

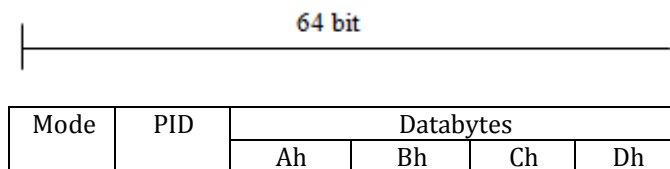

Fig 8. Overview of the proposed system consisting of three subsystems

The is followed by PID. For example, at an instance 0C to 0D represents engine RPM and vehicle speed. The final databytes field hold the values that should to converted to decimal before using it to compute values. The following table gives the hexadecimal code of the PIDs.

Table 2: Hexadecimal Code Description

PID (hex)	PID (Dec)	Data bytes to be returned	Description
-----------	-----------	---------------------------	-------------

01	1	4	Monitors status since DTCs cleared
02	2	2	Freeze DTC
03	3	2	Fuel system status
04	4	1	Calculated engine load
05	5	1	Engine coolant temperature

A mobile application is developed to receive and display these parameters for individual users. It requires the mobile device and the ELM327 adaptor to be paired via bluetooth to receive data from OBD-II. The OBD-II obtains data from ECU in the form of hexadecimal code and sends it to the mobile.

4.2 Processing unit

The processing unit is the second subsystem. The control information collected from the OBD-II is received by the application in the form of hexadecimal code. The hexadecimal code is then converted to decimal. The obtained decimal code is applied in formula to obtain values. Some of the formula to obtain values are specified.

$$\text{Mass Air Flow (MAF)} = \frac{(256 \cdot Ah + Bh)}{100} \tag{1}$$

Parameter : Mass Air Flow  
 Request Message : 7DF 01 10 0D 55 55 55 55  
 Response Message : 7E8 03 41 0D 32 aaaaaa

Fig 9. An example request and response message to measure Mass Air Flow

MAF is used to estimate the mass flow rate of air entering the fuel injected internal combustion engine. The air mass information is important for the ECU to balance and deliver the correct fuel mass to the engine. Byte A on converting to decimal yields a decimal value 1. Byte B when converted to decimal turns out to be 124. It is then applied in the formula to obtain MAF in terms of grams/sec.

$$\text{Engine Revolutions Per Minute (RPM)} = \frac{(256 \cdot Ah + Bh)}{4} \tag{2}$$

Parameter : Speed  
 Request Message : 7DF 02 01 0D 55 55 55 55  
 Response Message : 7E8 03 41 0D 32 aaaaaa

Fig 10. An example request and response message to measure speed

$$\text{Speed} = ((\text{Byte A})_{16})^{10} \tag{3}$$

7DF and 02 is in identifier section which represents request message and the length of the remaining data( 01 and 0D) respectively. The mode 01 shows the current data and 0D represent vehicle speed. The obtained response message on converting to decimal will give 50 km/hr as the vehicle speed. The obtained values are then displayed in the application.

4.3 Data visualization and storage unit

Our proposed system architecture involves wireless communication technology to upload the control information in the cloud storage (Firebase). This may be done by using 3G, 4G or Wi-Fi. The control information is uploaded to the cloud storage for future reference. A comparison chart or graph is generated. This helps the user to identify any deterioration in performance.

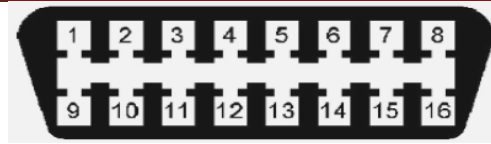

Fig 11. Structure of OBD-II

#### IV. Conclusion

The existing system of the fleet management system doesn't have a record for the status of their vehicle's performance for user purposes. Thus, compels the personal log for the diagnostics of the vehicle to monitor the condition before it could create a major infirmity at the middle of the driving. The status and data of vehicle's administration have been got from the Electronic Control Unit using the On-Board Diagnostic-II tool. Using the Bluetooth connection, the data has been stored in the firebase console. Using the application, the data that is stored in the cloud can be displayed in the form of graph generation. This system enables the user to have a record of the health status of the vehicle. The graph generation between the actual and the expected parameters warns the user about the predicament of the system. This helps the user to have constant monitoring of the system before it results in the major breakdown. The system does not carry out the execution when the vehicle's engine is turned off. This results in the loss of Bluetooth connection. This system can be further developed for error notification and continuous monitoring of the vehicle while driving.

#### References

1. Carlos T. Calafate, Chai KeongToh, Javier E. Meseguer, Juan Carlos Cano, and Pietro Manzoni. 2017. Driving Styles: A Mobile Platform for Driving Styles and Fuel consumption Characterization. *Journal of Communications and Networks. IEEE*, Vol 19, No 2, 1229-2370.
2. MalinthaAmarasinghe, SasikalaKottegoda, AsiriLiyanaArachchi, ShashikaMuramudalige, H. M. N. DilumBandara and Afkham Azeez.2017. Cloud-Based Driver Monitoring and Vehicle Diagnostic with OBD2 Telematics. *ACM*,Vol 18,No 5.
3. Jiyu Zhang, Hongyang Yao, and Giorgio Rizzoni. 2017. Fault Diagnosis for Electric Drive Systems of Electrified Vehicles Based on Structural Analysis. *Journal of IEEE Transactions on vehicular technology*, VOL. 66, NO. 2.
4. Chin E. Lin, Ying-ShingShiao, Chih-Chi Li, Sung-Huan Yang, Shun-Hua Lin, and Chun-Yi Lin. 2007. Real-Time Remote Onboard Diagnostics Using Embedded GPRS Surveillance Technology. *IEEE Transactions on VehicularTechnology*,Vol 56,NO. 3,1108.
5. Reza Malekian, Lakshmi Nair,BTMaharaj, Ntefeng Ruth Moloisane, Uche A.K. Chude-Okonkwo. 2016. Design and Implementation of Wireless OBD II Fleet Management System. *Journal of Latex Class Files*, Vol 13, No 9, 1530-437.
6. Yong Xie, Xin Su, Yifan He, Xuhui Chen, GengliangCai, BaishengXu, Wenjia Ye. 2017. STM32-based Vehicle Data Acquisition System for Internet-of-Vehicles. *IEEE Computer Society*,978-1-5090-5507.

---

## Paper on Accident Detection System using License Plate Identification

**1Jervin R, 2Lavanya M, 3Keshav S, 4Gokul kumar K, 5S Latha Bhuvaneshwari**

<sup>1,2,3,4</sup>UG Student, Department of CSE, SRM Institute of Science and Technology, Vadapalani Campus, Chennai, India

<sup>5</sup>Assistant Professor, Department of CSE, SRM Institute of Science and Technology, Vadapalani Campus, Chennai, India

---

**ABSTRACT:** *Nowadays the number of accidents in India is fairly increasing with the number of the cars increased. To stop this from happening and find out who when and how did the accident happen we are designing a droid car which can automatically find and prevent this from happening. The car will be having multiple sensors including the ultrasonic sensor, the IR Sensor and the accelerometer sensor, a camera to capture and record the event. And also the system will be connected to the GPS and the GSM(LTE) to give the location information to the police so that they can act accordingly and save life on the process. The car will be also equipped with Raspberry Pi 3 and cloud module which can accumulate all this data and come upon on a decision to help the victim and also use the license plate detection system to find the person or the individual who caused the accident and thereby the necessary actions could be taken accordingly.*

**Keywords:** VANET, MQTT, GPS, GSM, GPRS, Raspberry Pi 3

---

### 1. Introduction

Vehicle accidents on road has turned into a common issue due to several reasons like a swift rise in the vehicles amount, irresponsible drivers being increased and the absence of a good driving ability. Thus, comprehensive and precise safety systems must be developed in order to save the lives of people and also the vehicles. In the past one year, road accidents have reached to the highest worldwide, if info has been given to the authorities on time these road accidents could have been stopped. The system proposed by us works with a cumulative microprocessor in an effective IoT interface which does not involve human interaction.

The identification of the accident can be done in numerous methods, but the time taken to recognize the accident should be quick enough that the victims of the accident receive a timely help. The Accident detection system proposed here has three basic functionalities namely Detection, Broadcasting and Recording the whole incident live similar to that of a Black Box theory that has been implemented in Flights which thus makes them safer for updating and improvement. The system can be implemented on any car that has an infotainment system. Any car with an enabled GPS[2] location tracking and cloud is safe as MQTT[6] is being used to share the information to the nearby hospitals. VANET[10] and the license plate classification module under the hood is responsible for identifying the Hostile vehicle of the accident by image sensing techniques through collaborative remaking theory that involves breaking down a video into frames and scarp all the coded information in it. The Raspberry Pi 3[7] is coded with the algorithm that separates the frames and shares the images to the nearby control room or police personnel in order to record the accident prior to its unveiling. Wi-Fi[1] is to connect with cloud service which uses the location of the car to connect to the location of the nearby hospital to receive timely help and avoid death.

### II. Proposed System

There are various methods to identify an accident. The method that uses shortest time to recognize the accident and provide timely help is considered as an efficient method. The system has Detection, Broadcasting and Recording which are the three basic functionalities of the system. These functionalities act the same as a Black Box theory in Flights. The system can be implemented in any car with a GPS[2] tracking system and a cloud. MQTT[6] is used to send information to the nearby location hospitals. VANET[10] and the license plate classification module under the hood is responsible for identifying the Hostile vehicle by breaking down video into frames and scarp all the coded information in it with the help of image processing and image sensing techniques with collaborative remaking theory. The algorithm encoded Raspberry Pi 3[7] segregates the frames and passes the images to the nearby Police personnel so that the accident is recorded prior to its unveiling. The location of the car and the location of the nearby hospital is connected through cloud with the help of Wi-Fi[1] in order to receive help on time.



### III. Architecture Diagram

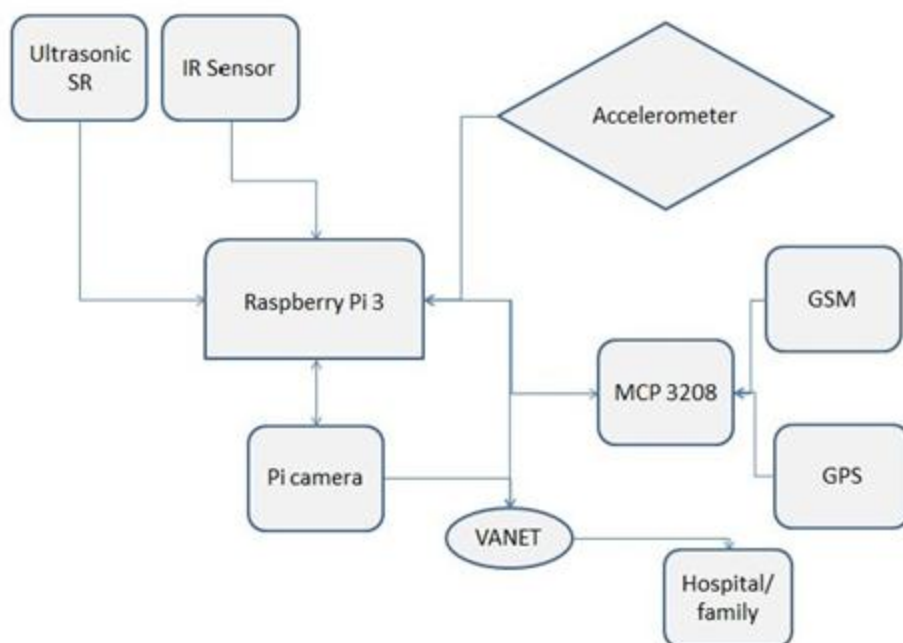

Figure 1: Basic Architecture Diagram

The architecture of the system proposed is overviewed in figure 1. The Arduino is connected to various components like satellite, volte modem, WiFi[1] module, camera, crash sensor and data base storage. The data base storage is connected to a processor that processes the data received and shares the output.

#### A) Raspberry PI 3modules

The raspberry pi 3 is the minicomputer which has the RAM and any other features includes within the size of a palm .The Raspberry Pi 3[7] can be easily connected to various accessories and connectable .The Pi[7] can be easily programmed by using the Python language and the Pi 3[7] also has its own operating system Called the Raspbian which is a Linux based OS Fig 4, and the LX terminal is used to add certain repositories which can be made use of to make successive and combined projects to work with and Pi 3 has a Wi-Fi[1] module inbuilt which can be activated by using the SSH server connection to communicate with the various servers and also to interact with the DB like the MySQL platform .Raspberry Pi[7] is also a computer processor which has GPIO pins to access input devices at ease.

#### B) PI Camera

The PI camera is accessible using the CSI Ethernet port and the camera uses a very flexible ribbon based IO connection which includes the output input and audio relay.Pi camera can also be programmed by using python with the camera modules

.The camera can be used to capture pictures and can be made to do video relay and the data can be easily saved over the SD card and can be used to make various calculations and findings over the data.

#### C) Sensor Module

i) Ultrasonic Sensor: An ultrasonic sensor emits an emotive signal of a powerful pulse frequency. If there is a hindrance in the path, the waves gets reelected back and are again received back on the receiver of the sensor. The range of interference is calculated based on the time taken by the actual pulse to reach the receiver.

Ii) ADXL335 Accelerometer Sensor: The ADXL335 is a simple 3-axis accelerometer to sense orientation in three dimensions. Its sensitivity in detection extends up to 3 g. Static motion can be sensed if gravity is to be



measured. Dynamic side motion can also be measured resulting from any kind of movement and therefore the datasheet of the axis and the direction of the vehicles or the object can be passed through various means. lii) IR SENSORS: Proximity IR sensors are used in various ways of detection and recognitions .IRs are mainly used to access the information of light by the use LED which when objected will send a response which can be used to detect and find the obstacle's before the projected object causes any contact .IR sensors also have the ability to send input signals to the controller thereby providing datasheet which includes object thermal print and thermal wave recognition.

**D) GPRS Module**

i) GPS: The GPS receiver is placed in the vehicle for two varied locating purposes. Firstly, it is used for tracking the vehicle location. The GPS [2] constantly tracks the vehicle throughout its working. Once, the GPS receives the accident signal from the sensor module, it retrieves the location of the vehicle which underwent the accident and appends it to the text file containing the UID of RFID tags. Secondly, the GPS unit begins a region based search for the closest hospitals on a radii basis. The search is conducted initially to find hospitals in the first one kilometer radius and later on increased to 2km, 5km radii and so on. The vehicle can also be tracked by the GPS using signals from the smart phones used by passengers inside the vehicle.

ii) GSM: GSM [8] is used as a module which is used to communicate between the servers and ISPs. It has its own classified character. Thereby, GSM is used to receive and send responses. With the GSM any numbers of connections to portal communications can be made. It is also highly usable and modifiable; hence GSM is preferred most for this mode of controlling. GSM (VOLTE) can be used. GSM receives co-ordinates from microcontroller and sends message to mobile number store in our system and also to identify the location coordinates and share them.

**E) License Plate Recognition:**

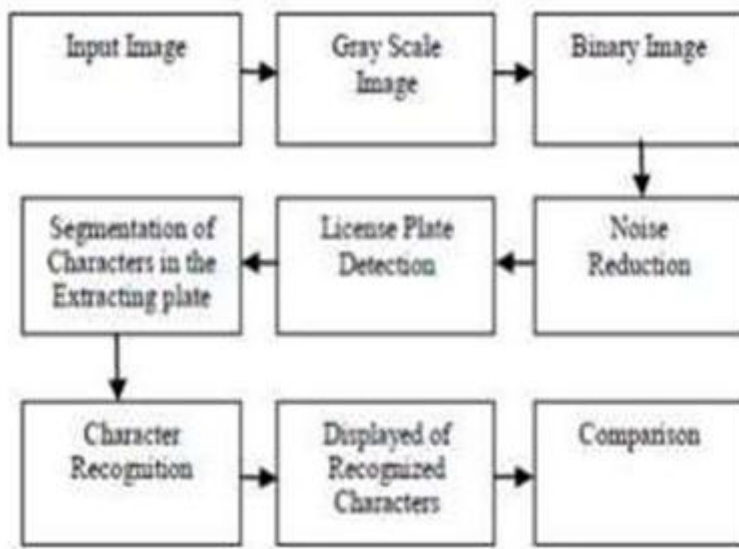

Figure 2: Block Diagram of Automatic Vehicle License Plate Recognition System

The basic step in recognition of vehicle number plate is to detect the dimensions of the plate. Generalization can be made. Hence we have to detect the edges of the plate. Open CV library gives us the means to access the data and to classify the parsed number into characters. It measures a set of parsed data depending on the length of the character. The bounding box algorithm is used to measure the properties of the region of Input image that has to be converted to 8-bit gray scale value is calculated. Commonly a monochrome color camera with a synchronous classifier and the camera color are equipped inside the front side of the device to capture the actual image preferences Fig 2. The values of the Highway datasheet position have been

captured at different hours, thus the changes in illuminations, HUE, white balance and weather conditions have effect on the image.

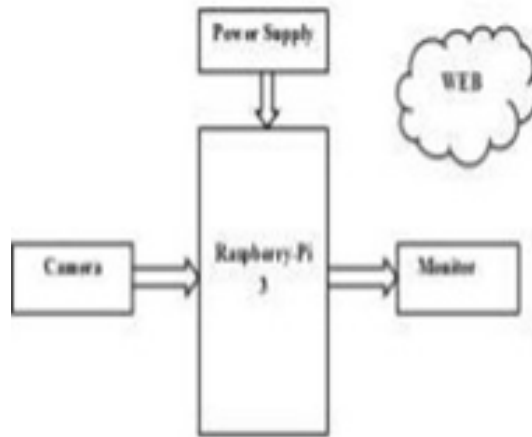

Figure 3: Transmitter

#### IV. Vanet

The primary goal of VANET[10] is to rise communicative response of users in the road and passengers comfort. VANET is that the wireless network where interaction takes place through wireless nodes mounted on each vehicle. Each node at intervals will respond to the other node by using the Wi-Fi hub and every node will be aligned with another intermediate node which will be in the center field of the vehicles through the line of contact. VANET are self-organizing network. There are many causalities' in VANET that are needed to be overcome in order to provide perfect services. Stable & re iable routing in VANET is one of the key issues which always keeps the connection between each node active which is very much needed for the participation of nodes.

The use of VANET with enrichment of routing protocol helps emergency amenities in finding the accident spot in rapid time within a large margin the arrival of emergency message. It also provides Communication between the sensors and the device and the car.

#### V. Result

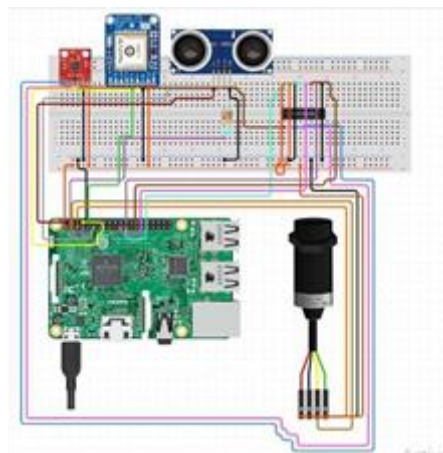

Figure 4: Circuit Diagram of Raspberry Pi 3

Thus the above show screenshot displays the basic connections implemented by using the raspberry Pi 3 and the data sheet for the project will be displayed using a monitor or a LCD screen and the receiver apps are actually used to send and receive the response from the vehicle and the necessary help will be acquired from the hospital and the family members which corresponds to the distributed messaging system.

## **VI. Conclusion**

This paper is proposed to detect the accident automatically and share information to the nearby hospital server in order to receive help in short time to avoid the situation to go out of control. This also shares pictorial information about the host vehicle of the accident to the nearby control room or police personnel. This proposed system is cheap and effective built on a powerful IoT base. Hence, this can be used in all the vehicles thus improving the safety system.

## **VII. Acknowledgment**

It's a privilege to express deep gratitude to My guide Mrs S. Latha Bhuvanewari, Associate Professor, Dept of CSE, HOD Dr. S. Prasanna Devi, Dept of CSE and SRM Institute of Science and Technology, Vadapalani Campus, Chennai who supported us throughout and for providing us with required facilities to carry out this work successfully.

## **Reference**

1. Prof.R.M.Sahu<sup>1</sup>, Namrata B.Gaikwad<sup>2</sup> , Chandrakant B.Sandage<sup>3</sup>, Vikram S.Shinde. "IoT Based Automatic Vehicle License Plate Recognition System".In ACL, 2017.
2. Badi Alekhya, S.Aarthi,V.Glory,. "Accident Detection with Location and Victim Information Transmission Using Raspberry Pi", 2014.
3. Akshatha.V, K.Nirmala Kumari. "Automatic Accident Detection and Intelligent Navigation System", 2018.

# Crop Yield Prediction with Minimum Expenditure for Proper Production using Random Forest Algorithm

Neelesh Kumar, Shreya Joshi, Nandkishore P, Vinit K  
SRM Institute of Science and Technology,  
Chennai, India

**ABSTRACT:** Agriculture has always played an important role in India's economic development with occupying 50% of the workforce and adding up to 18% of the country's GDP. However, the revenue from farming can further be developed by proper usage of technologies. The lack of awareness of existing technology has become a barrier for farmers to maximize their profit. Also, the variations in the season and other factors related to farming has restricted the production of the crop to a certain level. That is why we are in need a system that can predict things before so that farmers can plan accordingly. The idea is to consider all the details regarding the crop production and use it to effectively predict the type of crop grown in a particular region and the cost it can fetch in the market. At first, we gather all the factors concerning crop production in the financial year. The factors include the state in which the crop is being produced, the district in which it is located, the year it is being produced in, the season of that particular crop, the kind of soil it requires for its growth. Once all the factors have been taken into account, we use the random forest algorithm to classify the data based on the above-mentioned factors and obtain the type of crop being grown. Once we have obtained that we can use the area and the budget as inputs to calculate the minimum cost required for minimum production to remain at the profitable end.

## 1. Introduction

Data mining is a process of analyzing, extracting and predicting the meaning of full information from the huge data. Such a process is used in many companies to turn their raw data to useful information. Data mining techniques can be used in the field of agriculture to maximize the production of crops thus maximizing the profit which will, in turn, affect the GDP of the country [3]. The technology can be used to analyze the existing dataset and extract useful information from the given raw data. With the extracted information a prediction can, be made on the upcoming harvest [2]. Random forest algorithm (RFA) is implemented in this project. The RFA is used for classification and regression tasks.

The work includes several sections. The data from each section is analyzed and then used for prediction. Section I contains the input from the farmer [5]. In Section II the input from the farmer is taken and then analyzed and predicted. In the third section, the budget for the production is considered. In the final section, the budget input and the result from the first three sections are analyzed and a prediction is made on the crop that can give farmers a minimum profit.

## II. Problem Definition

Agriculture has and will always be an important part of one's life. There are many factors that affect agriculture like season and soil factors. India is a tropical country and each region of India experiences different seasons and the soil in each region is different. Similarly, their texture and moisture differ. Thus, all kinds of crops cannot be grown in all parts of the country. So, we must understand the soil [7] and season of a region before we decide the crop.

## III. Research Methodology

This section will cover the methods we have used for this study which consists of the study area, data set and methodology.

### 3.1 Related Work

The area of study [1] for this research is Maharashtra, Kerala, Tamil Nadu, Uttar Pradesh, and Madhya Pradesh, Bihar, West Bengal, Andhra Pradesh, Karnataka. Maharashtra is one of the western states of India. Agriculture is the most important industry. The major crops grown are Wheat, Rice, Jowar, Bajra, and Pulses. The state has 35 districts and 357 talukas [10].

Tamil Nadu is in the southernmost part of India. It shares its boundaries with Puducherry, Kerala, Karnataka, and Andhra Pradesh. Agriculture is one of the major industry in the state. The principal

food product of Tamil Nadu is Rice, Maize, Jowar, Bajra, Ragi, Bengal gram, Red gram, Green gram, Black gram, and Horse gram. The state is comprised of 33 districts and 418 taluks [9].

Kerala is a state which lies in the southwest part of India. It shares its boundaries with Karnataka, Tamil Nadu. The major food products produced in Kerala are coconut, rubber, tea, coffee, pepper, cardamom, areca nut, ginger, nutmeg, cinnamon paddy, and tapioca. The state is comprised of 14 districts and 77 taluks [11].

Uttar Pradesh is one of the 29 states of India. It lies in the north-central region of the Indian subcontinent. It shares its boundaries with 9 other states and with one international boundary i.e. Nepal. The major crops of these states are Wheat, Rice, Bajra, Gram, Jowar, Groundnut, and pulses. It is one of the most important states in India as far as horticulture is concerned. It has 75 districts out of which we have considered the district which has agriculture as their major business [12].

Madhya Pradesh is the second largest state in India situated in the central region of the country. It shares its boundaries with Gujarat, Maharashtra, Uttar Pradesh, Chhattisgarh, and Orissa. The major crops grown in this state are wheat, rice, Soya bean, Gram, Sugarcane, Maize and Arhar. We have considered 12 major districts out of 52[13].

Andhra Pradesh is the seventh largest and tenth most populous state in India. It shares its boundaries with Kerala, Karnataka, Tamil Nadu, Telangana, Chhattisgarh, and Odisha. It has totally 13 districts and 670 taluks. The major crops grown in Andhra are Tur, Bajra, Cotton, Rice, Maize, Niger seed and Groundnut [16].

Karnataka is the southwestern state in the country. It shares its boundaries with goa, Maharashtra, Tamil Nadu, Telangana, and Kerala. The major crops grown in the state are tur, ragi, rice, soybeans, and sunflower [17].

West Bengal is the fourth most populous state located in the eastern region of the country. It shares its boundaries with Odisha, Jharkhand, Sikkim, and Assam. The major crops grown in Bengal are jute, sugarcane, corn, wheat, and barley [15].

Bihar is the thirteenth largest state located in the eastern part of the country. It shares its boundaries with Bengal, Jharkhand and Uttar Pradesh. The major crops grown in Bihar are Rice, Wheat, Corn, and Pigeon pea [14].

### 3.2 Dataset Used

The datasets given below are taken from government records [1]:

Table.1- Raw Data

	state	district	year	season	crop	area	production	soil	msp
16823	Madhya Pradesh	ANUPPUR	2011	Rabi	Gram	3434.0	1764.0	black cotton soil	2100.0
27016	Maharashtra	SOLAPUR	2006	Rabi	Wheat	69400.0	85900.0	clay loam	650.0
15479	Karnataka	KODAGU	2013	Kharif	Rice	31917.0	91843.0	clayey soil	1250.0
6075	Uttar Pradesh	JHANSI	2003	Kharif	Jowar	6430.0	5817.0	clay loam	490.0
25786	Maharashtra	NASHIK	2008	Rabi	Jowar	8900.0	5200.0	clay loam	600.0
25041	Maharashtra	KOLHAPUR	2012	Rabi	Gram	9800.0	10800.0	black cotton soil	2800.0
17973	Madhya Pradesh	CHHINDWARA	2009	Kharif	Urad	9454.0	3053.0	clay loam	2520.0

State: The state where the crop is going to be cultivated. Each state experiences a season at different times. Each crop has a season to grow.

District: The geographical location of the place where the crop is grown is very important. With a change in a geographical area, the crops differ.

Year: Year parameter tells us which crop is grown in that particular year in the region

Season: Some crops grow only in one particular season. The season parameter shows which crops can be grown in that particular season.

Soil: The soil parameter tells the soil type to grow a particular crop [7].

MSP: Minimum support price (MSP) of a year give the least profitable rate at which the crop was sold in that year [8].

Area: The area available for the production of the crop is inputted by the farmer

Production: The amount of crop produced in a particular year is taken from the dataset

### 3.3 Methodology

All the below dataset is incorporated using Microsoft Excel.

Step 1: Getting the data of each district from every state from 2003 to 2013 from Government records.

Step 2: Acquiring the soil type, season, production and MSP for each crop to grow in that region

Step 3: Getting the details of the districts area, production of the year 2003 to 2013 from Government websites.

Step 4: The final dataset consisted of state, district, year, season, crop, area, production, soil, and MSP.

Step 5: All the irregular and inconsistent data are removed.

Step 6: For preparing the data set for applying the algorithm, unrequired columns were removed.

Step 7: The data set was then sorted on the basis of state and district.

Step 8: The area, production and MSP columns were considered for calculating the minimum price to be par with the profit price for the particular crop.

Step 9: This is then saved for processing.

### 3.4 Overview of the Model:

Data-Preprocessing: In this process, the data used is converted into Machine processable form using the Data Cleaning method. This dataset by which the model that has to be trained for the required output is split into training and testing dataset [6].

Table.2- data after preprocessing.

	state	district	year	season	crop	area	production	soil	msp
16823	6	139	8	1	8	3434.0	1764.0	12	2100.0
27016	3	75	3	1	3	69400.0	85900.0	15	650.0
15479	2	53	10	2	9	31917.0	91843.0	11	1250.0
6075	0	145	0	2	15	6430.0	5817.0	15	490.0
25786	3	252	5	1	15	8900.0	5200.0	15	600.0
25041	3	147	9	1	8	9800.0	10800.0	12	2800.0
17973	6	272	6	2	0	9454.0	3053.0	15	2520.0

Random Forest Classifier: The data is trained using Random Forest Classifier Algorithm. It is a Supervised Learning which can be used to train the model based on depths of the tree. For training, the predictive variables are State, District, Year, Season and Soil [4]. Considering these factors, the output variable crop is predicted using Random Forest Classifier Algorithm.

Crop Prediction: The Trained model is used for crop prediction based on the farmer input (State, district, Year, Season, Soil). Then using the predicted crop, the production cost is predicted using Random Forest Regressor, user must input the budget and area of the field for cultivation.

Random Forest Regressor: This is used to predict the cost of the predicted crop using the area and the predicted crop as input to the Random Forest Regressor.

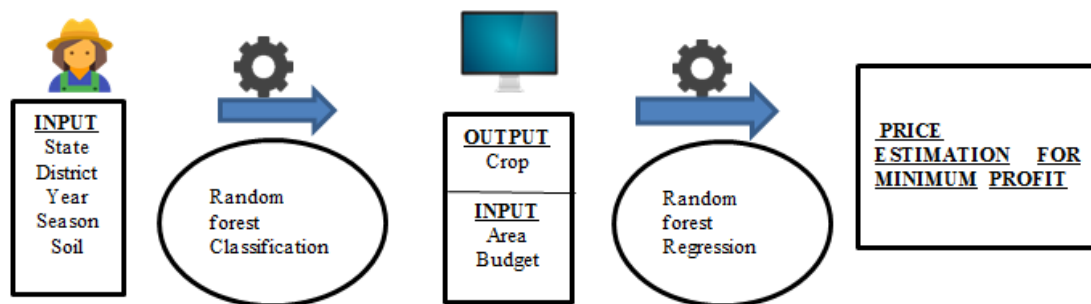



**IV Results and Analysis**

The given proposed system is used for the prediction of a crop that can be grown in a particular area. From the given user input the minimum price to remain at par with profit price is estimated. The prediction is done after considering the five factors from the given dataset which are state, district, year, season and soil. After considering the given factors from the dataset the crop is predicted.

From the given user input which is the budget and is the minimum price is obtained. For the given prediction we have used Random Forest algorithm. There are other algorithms that have been used for the prediction in the existing system, but none of them gives an accuracy above 66.6%[3]. The given algorithm has given an accuracy of 76.56% that helps in better prediction of crops.

Model Random Forest algorithm is a decision-making algorithm usually used for training large scale dataset. It takes the main factors of the dataset into consideration and using these factors it gives a quality output. There are many classification algorithms available but model Random Forest algorithm outperforms them in terms of scalability aspect.

**4.1 Result Comparison**

The algorithm used in the existing paper was useful in predicting the best crop. But the accuracy in prediction was only up to 62.251% for LAD tree and 66.225% for LWL. The inconsistency shown by the existing system has affected the crop yield badly. With the help of the random forest algorithm, the accuracy goes up to 76.56% which helps in better prediction of crops

Table.3- Result Comparison

Algorithm	Accuracy (%)
Lwl [3]	66.225
Lad tree [3]	62.251
Random forest	76.56

**V. Conclusion and Future Scope**

**5.1 Conclusion**

In this paper, we have taken into consideration the possibilities for a better crop prediction using data mining. For the research, we have taken 9 states into consideration Maharashtra, Kerala, Tamil Nadu, Uttar Pradesh, Madhya Pradesh, Andhra Pradesh, Karnataka, West Bengal and Bihar with a total district count of 303. With the Random Forest algorithm, we have got an accuracy of 76.56% on the prediction of the crop. The major factors for prediction of the crop are soil type, season, year, state, district.

**5.2 Future Scope**

In the future, we can create a crop recommendation system that can be used for prediction with wider parameters. This could help in better crop recommendation with a higher level of accuracy.

**References**

1. Data set used, <https://data.gov.in/resources/district-wise-season-wise-crop-production-statistics-1997> last accessed on 15<sup>th</sup> march ,2019
2. Ansif Arooj, Mohsin Malik, Naeem Akram," Evaluation of Predictive Data Mining Algorithms in Soil Data Classification for Optimized Crop Recommendation", April 2018, IAN-17684643
3. Shruti Mishra, Priyanka Paygude, Snehal Chaudhary, Sonali Idate," Use of Data Mining in Crop Yield Prediction",2018
4. Neha Khadke.Divya More, Pooja Patil, Harshali Patil," Agriculture Decision Support System using Data Mining",2017.
5. Veenadhari, Bharat Mishra, CD Singh," Machine learning approach for forecasting crop yield based on climatic parameters",2014
6. R. Sujatha, P. Isaki," A Study on Crop Yield Forecasting Using Classification Techniques",2016, ISN-16426980
7. Soil Type, <https://www.agrifarming.in/>
8. MSP dataset, <https://data.gov.in/resources/minimum-support-priceprocurement-price-crops-crop-year-basis>



9. Tamil Nadu,[https://en.wikipedia.org/wiki/Tamil\\_Nadu](https://en.wikipedia.org/wiki/Tamil_Nadu)
10. Maharashtra,<https://en.wikipedia.org/wiki/Maharashtra>
11. Kerala<https://en.wikipedia.org/wiki/Kerala>
12. Uttar Pradesh,[https://en.wikipedia.org/wiki/Uttar\\_Pradesh](https://en.wikipedia.org/wiki/Uttar_Pradesh)
13. Madhya Pradesh,[https://en.wikipedia.org/wiki/Madhya\\_Pradesh](https://en.wikipedia.org/wiki/Madhya_Pradesh)
14. Bihar,<https://en.wikipedia.org/wiki/Bihar>
15. West Bengal[https://en.wikipedia.org/wiki/West\\_Bengal](https://en.wikipedia.org/wiki/West_Bengal)
16. Andhra Pradesh,[https://en.wikipedia.org/wiki/Andhra\\_Pradesh](https://en.wikipedia.org/wiki/Andhra_Pradesh)
17. Karnataka,<https://en.wikipedia.org/wiki/Karnataka>

# Computing Minimum Support Price to Promote Agriculture as A Sustainable Model

R Nitin, R Ramasubramanian, Shriya Suresh, KPK Devan

Department of Computer Science and Engineering,  
Easwari Engineering College,  
Chennai, India

**ABSTRACT:** *In a world where every business sector is thriving to prove its place and move to larger revenue streams, the plight of Indian farmers still remain in trying to make the bare ends meet. With a loosely coupled system of farming practices and an even more aloof mindset of treating agriculturalists, the world might be led into a future where food becomes luxury only for the super rich. Even though the Indian government has tried to take a lot of measures to help agriculturalists from the clutches of private contractors, the Minimum Support Price (MSP) set by the government is not profitable. The downfall of produce or the market demand might be a cause of poor distribution across the area or due to a climatic drift which might have caused a dip in the cultivation of crops. Even after a lot of such constraints being studied by the government in collaboration with various agricultural groups, MSP still falls short of the farmer's requirements. Using Machine Learning, specifically SVM classifiers and cross validation, the proposed system suggests the most profitable crops that can be cultivated in that particular region and the predicted selling price i.e., MSP of the produce. Hence, the idea will create a win-win situation for the farmer as well as the government wherein the farmer will be aware of his production and the rate at which he must sell it to sustain in his occupation.*

**Keywords:** *Minimum Support Price, Machine Learning, Support Vector Machine, Cross Validation.*

## 1. Introduction

Agriculture is one of the most important sectors in India with respect to both economy and employment. It constitutes to 50% of national employment and 18% of the GDP. Minimum Support Price (MSP) is the market intervention by the Government of India which is set at the beginning of the sowing season for the major crops. In Spite of constant effort of the Government to promote agriculture, the pricing does not meet the expectations of the farmers. In order to overcome this issue and as a step ahead to smart agriculture, a real time system is proposed that predicts the profitable crops for a particular cropping season and the MSP for the crop.

The need for this system is that most of the time farmers are unaware of their harvest's worth and end up in loss. This situation has to improve in order to make agriculture a sustainable venture and encourage more youngsters to take up agriculture as their occupation. To achieve this there should be a proper pricing system that ensures profit to the producer like in any other industry.

The concept used in system is Machine Learning. Machine Learning has found its application in various industries with agriculture being in its early development stage. Machine Learning algorithms allows for accurate and real-time prediction with respect to agriculture based data. The objective of using Machine learning algorithms, particularly Vector Machine, is to perform both comparison and prediction on the different parameters that we are to consider in the system. The proposed system thus aims to apply the machine learning algorithm and data analysis on the agriculture parameters of a given location and the farmer's possible expenditure to provide an output that suggests the farmer with best crop which is profitable and the market price in which it has to be sold. In the remainder of the paper the literature survey (Section 2) and the proposed system design (Section 3) will be described. The results and discussions are presented in Section 4. The last part (Section 5) concludes the paper and explains the future scope of the project.

## II. Related Works

There has been limited research papers published on Agricultural improvements using Machine Learning even though agriculture is one of the most essential sectors in the nation and ML is a evolving research field. To develop our proposed system, some of the research papers and studies are discussed in this section.

Anup K. Prasad et. al., [1] proposed a paper on Crop yield Estimation using Remote sensing and surface parameters. This paper talks about remote sensing and yield prediction. The parameters considered for the prediction includes crop region selection, yield data, vegetation index, precipitation and soil temperature.

Soybean crops in Iowa are taken to sample the proposal. It is concluded that using regression techniques and the numerous considered parameters, an accurate yield prediction is possible. The issue in the paper is that it is localised and works only for one crop at a time.

John M. Mulvey, [7] submitted a review on Machine Learning and Financial Planning in which, various financial scenarios such as high frequency trading, bonds, economic regime identification are considered. Application of machine learning and Reinforcement learning with respect to these financial scenarios are discussed. The difference between ML and decision algorithms are observed. We compare this to our project sighting the number of parameters involved in computation. The paper discusses in brief about supervised learning and the different decision models such as Markowitz portfolio model, cross validation approach and portfolio design.

Konstantinos G. Liakos et. al., [9] published a paper on Machine Learning in Agriculture. In this paper, ML models such as Regression, clustering, bayesian model, decision trees, SVM are analysed. These techniques are used to find crop yield prediction using factors such as soil quality, crop diseases, weed quantity, crop quality, etc. Another method analysed is by identification and training of a particular plant production in northern america so as to reduce intensive labor.

Nagini.S, et. al. [11] have proposed in a conference about the Agricultural Yield Prediction using Predictive Analytics Techniques. In this paper, the raw data collected from the farm location, is pre-processed to remove noise, refined and finally through feature selection required data is filtered and using regression a predictive model is built. All regression techniques are used to compare the yield with area in hectares and the crop used. The issue in the model is that they have only predicted the expected yield and have not analysed other factors like weather.

Shubhangi S Wankhede et. al. [16] proposed the paper in which through Associative Rule Mining the effect of drought in 23 districts of Maharashtra was analysed, taking data from 1983 to 2012. The rainfall, crop yield and impact were classified into three levels (high, medium, low) and based on Apriori algorithm in WEKA, the level of impact was determined based on rainfall and yield level. The results are then graphically analysed and the final impact is being calculated based on rule mining. This system could be extended to compute the loss incurred by the farmer due to the computed impact and this could be used to evaluate a minimum support price to attain a no-loss scenario.

Sjaak Wolfert et. al. [18] proposed a review paper on the Influence of Big data on Smart Farming. This paper talks about the existing big data concepts in farming, the changes due to its introduction and the challenges faced in the data collection and data processing. The research was carried out by collecting all papers related to big data and farming from January 2010 to March 2015. They concluded that big data techniques and trends are found only in Europe, North America, and China. Smart Farming is in its early development stage and some of the challenges faced are ownership, quality and openness of the data collected from farms.

These studies provide a basic idea on the existing systems and undergoing research fields. Furthermore it emphasizes on the fact that there are very limited established project proposals that suggest and predict a cropping pattern which is profitable to the farmers and at the same time beneficial for the Government.

### III. Proposed System

In the proposed system, the idea involves using parameters pertaining to the user location to create a suggestion system that gives a recommendation to the farmer. This will not only help the producer understand the business behind agriculture, but also encourage switching to smarter methods of cultivation. The suggestion gives a list of crops which has higher possibility to be profitable to the farmer. Profit is calculated using the expected cost price which is the user's input.

The user interface is an interactive application where the location and cost price are collected from the user. The output is the suggestion list. Data collection and storage is cloud based and data is retrieved and processed using Hadoop Distributed File system. The processed output is used as the test set for the automation stage. Machine Learning is used to compute the suggestions. Support Vector Machine is the model used in the ML stage. SVM is chosen for the ability to compare and predict concurrently.

#### 3.1 System Overview

The overall functioning of the proposed system is as given in Fig.1.

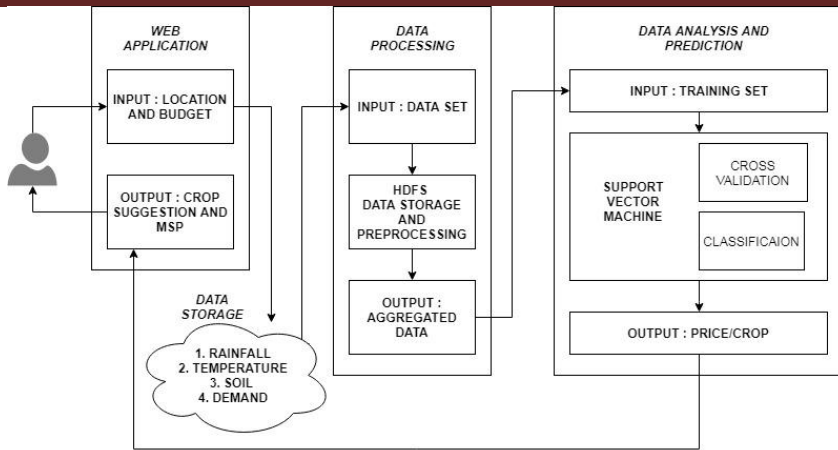

Fig. 1. Functional Diagram of the Crop suggestion and MSP prediction system

### 3.2 Data Storage and Processing

The Data Storage module is primarily a data retrieving (from cloud) and processing (using hadoop) module. While the future of the system will be to collect data real time, the current prototype is run locally. The collected data is uploaded to a cloud system to foresee distributed access. The cloud service DROPBOX is used to store and manipulate data in the cloud platform. The dropbox SDK for Java is used to upload and download files via the file handling techniques of Java. The files are retrieved to the host system using Hadoop where it is processed in HDFS. While the need for cloud storage is not needed currently, it is a must during real time deployment since distributed access is guaranteed through the use of cloud.

Big Data is a concept involving processing of three types of data namely structured, semi structured and unstructured data. Structured data includes data which are structured based on a table format for example csv files and xls files. For our local processing we gathered data which are in the format of JSON files. This file type is mostly used for data transfer through web servers and web services. The json files are of the type semi-structured data with respect to Big Data classification. Hadoop is needed to handle massive amount of real-time data which are to be processed in the future.

In Hadoop Data Processing, the Map Reduce operation is carried out and the data is sorted and stored in the HDFS file system. The HDFS file system is a special file handling system to traverse into the file directories in the Hadoop distributed systems of the cluster we are using. As hadoop tool can be run on any commodity hardware large amount of data related to our research can be processed and stored at ease.

The data stored in HDFS after MapReduce operation can be easily retrieved as the data logs are always stored in the Namenode. Another task is to bring the input and output of the HDFS to the same status quo. The processing of data happens for each and every parameter of the function. The output of the distributed file system is the Aggregated data set that becomes the test set to the computation module.

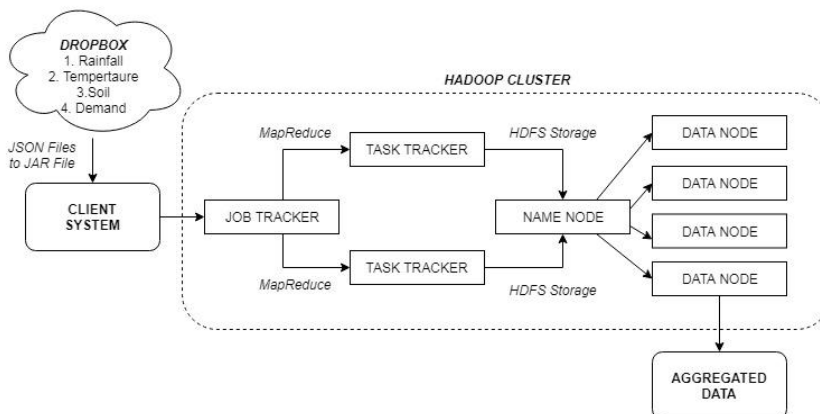

Fig. 2. Module diagram of the data storage and processing unit

### 3.3 Data Prediction and Analysis

Support Vector Machine is used to perform the machine learning operations. SVM is chosen for the following reasons :

- Satisfies the complexity of the project
- Can perform computation and prediction concurrently
- Unstructured data can be processed
- Better for high dimensional data

Specifically , k fold validation and classification are used for the prediction.

The number of overlapping data sets that are folded include the demand, rainfall, temperature and soil type of the designated location. The output of the cross validated data sets are the features i.e., the dependant and independant variables from the collected data sets. The relation between the features are foreseen using the formula that has been devised by us and thus the most profitable crops are chosen.

Machine learning is used in to analyse the data and predict the profitable crops. Support Vector is used to achieve the desired results. To be specific, classification and cross validation is used.

SVM is a matrix based algorithm where the concept of hyperplanes and hyper space come into picture. A SVM performs classification by finding the hyperplane that maximizes the margin between the two classes. The vectors (cases) that define the hyperplane are the support vectors.

Cross validation is used to find the best combination of hyper parameters that are to be used in the classification process. Even though cross validation is more useful while the model is not fully trained, we use CV for future purpose when the data sets that are obtained in real time are semi or unstructured and there is not much training done.

In a k-fold validation, the number of datasets on the hyperplane and the planes which overlap each other are plotted on hyper space; the overlapping data is validated and pushed for classification.

Firstly, an instance of Hadoop is opened and the datasets in process are extracted based on the user specification. Then, a classifier function is created where the machine learning implementation is specified. Random forest is used as a platform to run SVM and k-fold validation. This is to ensure smoothness in the working of the algorithms. RF structure priming is carried on by specifying the number of nodes, the activation function, number of layers and the status quo of the RF. Now, a predictor class is created where the datasets are split into training and testing set respectively. Similarities between the training and testing set are checked.

Lastly, a classification function is created. In the SVM classification function, the classifier is built and the trained sets are used to predict the crops that are in contention.

Based on the number of companies that take agricultural goods as the primary raw product and the budget that is bestowed by the farmer, profit calculation is done. Now, the most profitable crop along with the profit that the customer must aim at is delivered back to the application module.

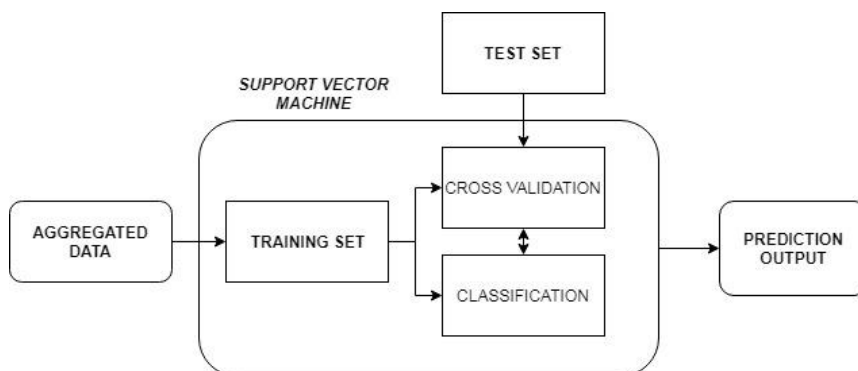

Fig. 3. Module diagram of the data prediction unit

### 3.3 Web Application

The user application is a website. A website is deemed most convenient because of the following reasons :

- Is is a more commonly available approach and has a wider outreach
- System requirements can be made lesser so as to accommodate usage even in remote places

- It is easier to use than a mobile application or a desktop application

Javascript is used to design the backend of the website. Jscript is an object-oriented computer programming language commonly used to create interactive effects within web browsers.

The input from the user is taken by using the concept of forms. The various inputs are the state to which the user belongs, the district in the state, the number of days of cultivation he is aiming at and the budget that can be allocated for the cultivation. The output is given as a list of the crop(s) and the profit that can be aimed at by the farmer.

#### IV. Results and Discussions

##### 4.1 Test Cases

Since both suggestions and the price is given as output, let us consider the price alone for framing the test cases.

##### 4.1.1 Test Case- I

Assuming the suggested crop as rice in an area with average yield production and an average demand The current scenario is as follows :

**Table 1:** Current Calculation of MSP for Rice

Produce/Acre (min)	Cost/Acre (min)	Avg. MSP/Kilo (max)	MSP/Acre (max)
1500 Kg	₹ 40000	₹ 20	₹ 30000

By using our system of making farmers aware of how much they must be aiming the profit at, the changes are as follows :

**Table 2:** Proposed Calculation of MSP for Rice

Cost/Acre	Demand	Predicted selling price
₹40000	Medium	₹42250

##### 4.1.2 Test Case- II

Assuming the suggested crop as sugarcane in an area with average yield production and high demand.

The current scenario is as follows :

**Table 3:** Current Calculation of MSP for Sugarcane

Produce / acre (min)	Cost / acre (min)	Avg. MSP / kg (max)	MSP / acre (max)
2000 kg	₹ 30000	₹ 2	₹ 40000

Based on an input given in the website, let us create a table where we convert the user input data to the general form and then compare :

**Table 4:** Proposed Calculation of MSP for Sugarcane

Cost	Demand	Predicted selling price
₹ 50000*	High	₹ 65000*

\*If the total cost for production is taken as ₹ 50000, it can be assumed that the are covered is about 1.66 acres (50000/1.66 is the cost per acre). The selling price of ₹ 65000 is equated to ₹44000/acre.

##### 4.2 Performance Analysis

Rice and sugarcane are taken to analyse the difference in prices between the current system and the proposed system. Rice is suggested in a location with average yield and average demand. Sugarcane is

suggested in a place with high demand. It is seen that while the difference in sugarcane price is not very high, rice has a major change. Rice is one of the most cultivated crops in India and at the same time, it is lucrative only to very large scale farmers thus making it a less profitable cultivation.

- The parameters taken into account for analysing is as follows :
- The tentative cost involved in cultivation per hectare ( converted to per acre value )
- The price of crops per quintal ( converted to cose per kilogram )

The observed increase in the price of rice is around 40% and the increase in price of sugarcane for an area of high demand is around 10%. While the exact amount may not be pleasing to the buyer of the crops, it is an eye opener for the farmers who have only seem downfalls till date.

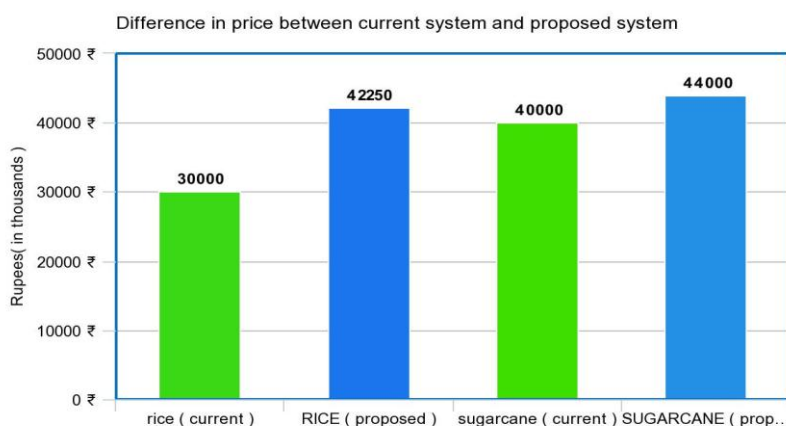

**Figure 4.1** Graph analysing discrepancy in the current system and the proposed system

## V. Conclusion

Hence the proposed agriculture cropping suggestion and price prediction system has the following functionalities namely, providing a profitable scenario to the farmers and making them aware of their crops' worth. The simple user interface allows the farmer to input his location and expected expenditure which then connects to the server block where the algorithm computes the cropping suggestion and MSP and displays the same to the farmer. The algorithm is an improvement to the current systems as it considers all the environmental and economic factors with respect to that particular location.

The project can be extended in a way where the parameters are collected directly from the farm lands using sensors and the real time data can be used to dynamically provide the crop suggestion and MSP. Also with the support of Government this can be implemented on large scale and benefit the farmers across the nation thus building an economically stable agriculture system.

## References

1. Anup K. Prasad, Lim Chai, Ramesh P. Singh, Menas Kafatos (2006) 'Crop yield estimation model for Iowa using remote sensing and surface parameters', International Journal of Applied Earth Observation and Geoinformation Elsevier, pp.26-33.
2. Aybar-Ruiz A., Jiménez-Fernández S., Cornejo-Bueno L., Casanova-Mateo C., Sanz-Justo J., Salvador-González P., Salcedo-Sanz S. (2016) 'A novel Grouping Genetic Algorithm-Extreme Learning Machine approach for global solar radiation prediction from numerical weather models inputs', Sol. Energy. 2016 Vol.132, pp.129-142.
3. Barmounakis S., Kaloxylas A., Groumas A., Katsikas L., Sarris V., Dimtsa K., Fournier F., Antoniou E., Alonistioti N., Wolfert S. (2015) 'Management and control applications in Agriculture domain via a Future Internet Business-to-Business platform', Information Processing in Agriculture 2, pp. 51-63.
4. Cramer S., Kampouridis M., Freitas A.A., Alexandridis A.K. (2017) 'An extensive evaluation of seven machine learning methods for rainfall prediction in weather derivatives', Expert Syst. Appl. 2017, Vol.85, pp.169-181.
5. Duan Y. E. (2011) 'Design of intelligent agriculture management information system based on IoT', IEEE Computer Society Vol. 1, pp. 1045-1049.



6. Jan G. De Gooijer, Rob J. Hyndman (2006) 'A look into the future of electricity price forecasting', *International Journal of Forecasting*, Elsevier pp.443-473.
7. John M. Mulvey (2017) 'Machine learning and financial planning', *Financial Technology IEEE Potentials* Vol. 36, pp.8-13.
8. Jordan M. and Mitchell T. (2015) 'Machine learning: trends, perspectives, and prospects', *Science* Vol. 349, pp. 255–260.
9. Konstantinos G. Liakos, Patrizia Busato, Dimitrios Moshou, Simon Pearson, Dionysis Bochtis (2018) 'Machine Learning in Agriculture: A Review', *US National library of medicine* Vol. 18, issue 8, pp.7-10.
10. Liliya Demidova, Evgeny Nikulchev, Yulia Sokolova (2016) 'Big Data Classification Using the SVM Classifiers with the Modified Particle Swarm Optimization and the SVM Ensembles', *(IJACSA) International Journal of Advanced Computer Science and Applications*, Vol. 7, No. 5, pp.294-312.
11. Nagini S., Dr. Rajini Kanth T.V., Kiranmayee B.V. (2016) 'Agriculture Yield Prediction Using Predictive Analytic Techniques', *2nd International conference on Contemporary computing and Informatics* , pp.783-788.
12. Priyadarshini A., and Agarwal S. (2015) 'A MapReduce based Support Vector Machine for Big Data Classification', *International Journal of Database Theory and Application* Vol.8, no.5, pp.77–98.
13. Rafal Weron (2014) 'A look into the future of 'electricity price forecasting'', *International Journal of Forecasting*, Elsevier Vol.30, issue 4, pp.1030-1081.
14. Raikwal J.S., and Saxena K. (2017) 'Performance Evaluation of SVM and K-Nearest Neighbor Algorithm over Medical Data set', *International Journal of Computer Applications* Vol. 50, no. 14, pp. 35–39.
15. Shuang Gao, Yalin Lei (2017) 'A new approach for crude-oil price prediction based on stream learning', *GeoScience Frontiers*, Elsevier Vol.8, issue 1, pp.183-187.
16. Shubhangi S Wankhede, Leisa J Armstrong, Niketa Gandhi (2017) 'Characterising the Influence of Drought on Jowar Crop Production in India using Association Rule Mining', *IEEE International Conference on Technological Innovations in ICT for Agriculture and Rural Development (TIAR 2017)* pp.57-63.
17. Sinduja .T, Sakhi Chawda, K.P.K. Devan, (2018), 'Survey on Price Prediction Techniques' *International Journal of Scientific Research in Computer science, Engineering and Information Technology*, Vol. 3, Issue 1, pp. 1449-1453.
18. Sjaak Wolfert, Lan Ge, Cor Verdouw, Marc-Jeroen Bogaardt (2017) 'Big Data in Smart Farming - A review', *Agriculture Systems*, Elsevier Vol. 153, pp.69-80.
19. Taniguchi M., Masuhara N., and Burnett K. (2015) 'Water, energy, and food security in the Asia Pacific region', *Journal of Hydrology: Regional Studies* Vol. 11, pp.9–19.

# Application of Growing Neural Gas as A Validation Function

Shreyas Keelary, S Jeyendra, CB Ajay Vishaal, Saket Suman, Dr. G Paavai Anand  
Professor,  
Department of Development Studies,  
University of Dhaka Bangladesh, Bangladesh.

**ABSTRACT:** This study shows that we can use Growing Neural Gas (GNG), a classification algorithm, as a viable validator for a regression network. Validation is important in any data analysis, as it is responsible to eliminate incorrect data predictions from being used as reference points in estimation models. The existing technique used for validation is incapable of adjusting to new data without the need of complete recalculation. It is also incapable of batch processing. This, by default, raises the number of calculations required to validate the model. In the proposed technique, after the model has been trained to validate a certain network, there is no need to retrain the model as in regression for every change imposed upon the network. The predicted values of  $Y$  (output variables) are compared to the existing topology of the present data. The GNG once trained to the topology of the present data will be capable of rearranging itself to a reasonable extent to fit any data that comes in. The predicted values of the dependent variable " $Y$ " provided by regression algorithm is treated as the input to the GNG. If these values are classified as in same cluster like other values of the same regression lines, then these new values can be accepted as valid inputs. This not only eliminates the need to retrain repeatedly, it also reduces the execution time drastically by a factor of  $10^4$ .

**Keywords:** Growing Neural Gas, Goodness-of-Fit, Regression, Validation

## 1. Introduction

Classification algorithms, as the name suggests are a set of machine learning algorithms for dividing data into classes pre-defined by user. Classification algorithms like Naïve Bayes and Bayesian classifier utilize probability as a measure to decide whether a certain point belongs to any class. Algorithms like KNN utilizes the relative distance from nearby clusters. Growing Neural Gas is a neural network based classification algorithm which learns the topology of the points in the dataset and classifies any new incoming node based on similarity to either classes.

Growing Neural Gas, proposed by Bernd Fritzke, is a subset of neural gas algorithm that uses unsupervised learning and vectors to study the topology of the given network. [1] Unlike the previous 'neural gas' approach suggested by Martinetz and Schulten (1991-1994), the proposed model has no time-variant parameters and is capable of continuous learning. [2]

'The Kohonen feature map' (Kohonen, 1992) and the 'growing cell structure' (Fritzke 1994b) permit projection of multi-dimensional data onto a properly sampled, sub-divided spaces of dimensionality which are chosen prior to application. [2] All these algorithms are utilized for classification for a set of data with a given topology, a network trained to the topology will be capable of validating any new points which should belong to the topology. This is the purpose we aim to achieve with the Growing Neural Gas. Here, it is used as a validator to validate gaming metrics like response time and accuracy.

## II. Background

Analysis using regression has earned wide use in the analysis of data and in developing empirical models. If the results produce an adequate fit, one uses it for predicting future outcomes, control or even decode the mechanism resulting in the generation of the data. Before using a model, it should be made sure that it is valid and relevant enough. The prime reason for usage of regression models is to depict any kind of relationship amongst a set of variables namely predictor variables and other being its responses ranging from one or more. "Generally, the model, or equation, is of the linear form.

$$E(Y) = \beta_0 + \beta_1x_1 + \beta_2x_2 + \dots + \beta_px_p \quad (1)$$

where the  $\beta$ 's are coefficients to be estimated from the data. Some of the following practices are useful in ensuring that the regression models are valid

- 2.1. Comparison of the model predictions ( $\hat{y}$ ) and coefficients ( $\beta_i$ ) with physical theory
- 2.2. Collection of new data to check model predictions
- 2.3. Comparison of results with theoretical models and simulated data.
- 2.4. Reservation of a portion of the available data to obtain an independent measure of the model prediction accuracy". [3]

All the above being fairly impressive in validating the regression models, lack in the ability to perform the validation when there is a newly emerged data point in the dataset.

The technique 2.1 is not sufficient because addition of new data might not fall within the existing physical theories and is not enough to certify the integrity of the model.

Therefore, technique 2.1 is sparingly used for validation of existing data only. The technique 2.2 is closer to our approach of validation. It seems like a plausible justification that a particular theoretical model is acceptable if the predictions provided by the model can accommodate the predictions of new data. This approach supports the utilization of minimum required checkpoints as a worthy method of validation.

The technique involving 2.3 compares and contrasts the result with theoretically existing proofs. There might be instances of models being too complex for real-life practice, leading them to cause issues in actual use if ignored.

The final technique 2.4's drawback is that it is being repeated iteratively, causing it to lose its maxima and minima. In other words, it gives us a blunt result. Although the user has control over the number of iterations, model becomes inaccurate along with the increase in iterations.

The reason we use Growing Neural Gas in validation to overcome the existing algorithm's drawback which is high processing time for validation. As the number of epochs in neural networks increases, the number of times a particular statistic has to be recalculated increases proportionally which increases the computational expense manifold. As the size of 'k' increases, the number of calibrations also increases and again the above scenario plays itself. [4].

### III. Existing Methodology

Goodness of fit revolves around how efficient the observed data corresponds to the fitted model. In linear regression, the observed values are compared to the predicted values.

"A goodness-of-fit statistic tests the following hypothesis:

$H_0$ : the model  $M_0$  fits

vs.

$H_A$ : the model  $M_0$  does not fit

(or, some other model  $M_A$  fits)

Most often the observed data represent the fit of the saturated model, the most complex model possible with the given data. Thus, most often the alternative hypothesis ( $H_A$ ) will represent the saturated model  $M_A$  which fits perfectly because each observation has a separate parameter.

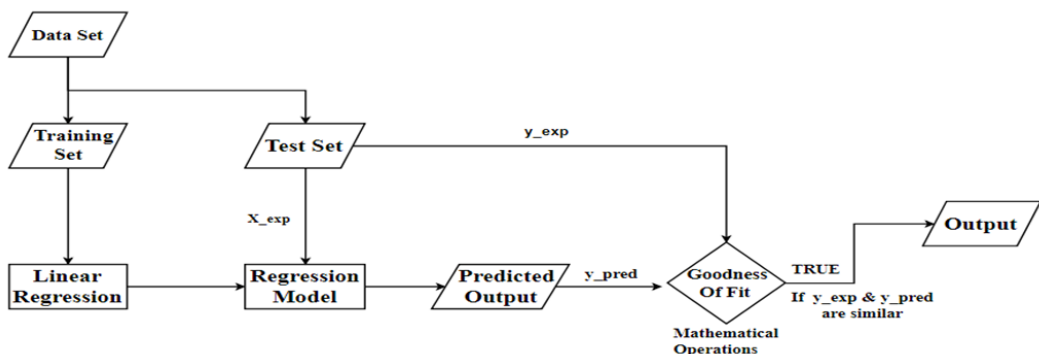

Fig. 3.1 represents the module diagram of the existing system. Here, the dataset is divided into a training and test set. The training set is used to train a regression model. The test set contains a 'X\_pred' which is the independent variable and 'y\_exp' which is the dependent variable. The independent variable is supplied to the regression model and a predicted output 'y\_pred' is obtained. The deviance and the Pearson goodness of fit statistic is calculated during every epoch in case of a neural network.

### 3.1 Pearson Goodness of Fit statistic:

$$X^2 = \sum_{j=1}^k \frac{(X_j - n\pi_j)^2}{n\pi_j} \tag{2}$$

$X^2$  is the observed count in cell  $j$ ,  $n\pi_j$  is the expected count in cell  $j$ , provided the null hypothesis is holds true, i.e. the assumed model is effective. Notice that  $\pi_j$  is the estimated (fitted) cell proportion  $\pi_j$ , under  $H_0$ .

### 3.2 Deviance Statistic

$$G^2 = \sum_{j=1}^k X_j \log \frac{X_j}{n\pi_j} \tag{3}$$

where log is a natural logarithm.

$G^2$  is also called the likelihood-ratio test statistic, for comparing the likelihoods ( $l_0$  and  $l_1$ ) of two models, that is comparing the loglikelihoods under  $H_0$  (i.e., loglikelihood of the fitted model,  $L_0$ ) and loglikelihood under  $H_A$  (i.e., loglikelihood of the larger, less restricted, or saturated model  $L_1$ ):

$$G^2 = -2 \log \frac{l_0}{l_1} = -2(L_0 - L_1)$$

. Both the above measures depend on the observed data  $X$  and a vector of the probabilities  $\pi$ .

### 3.3 Testing the Goodness-of-Fit:

$X^2$  and  $G^2$  both measure how closely the model,

- I. If the sample proportions  $p_j = X_j / n$  (i.e., saturated model) are exactly equal to the model's  $\pi_j$  for cells  $j = 1, 2, \dots, k$ , then  $O_j = E_j$  for all  $j$ , and both  $X^2$  and  $G^2$  will be zero. That is, the model fits perfectly.
- II. If the sample proportions  $p_j$  deviate from the  $\hat{\pi}$ 's computed under  $H_0$ , then  $X^2$  and  $G^2$  are both positive. Large values of  $X^2$  and  $G^2$  mean that the data do not agree well with the assumed/proposed model  $M_0$ ." [5]

Neural networks being stochastic models introduce a randomness while training the model, like shuffling the data taken in each epoch or random initial weights, etc. This means that the same model may give different predictions each time it is fit for the same data. In addition, each epoch entails a new goodness of fit not to count the number of iterations being run. Both these methods require recalculating the measures in case of addition of new data which would involve a lot of processing overhead to be performed in a real time scenario.

In existing system,

$$\text{Number of Calculations} = N \times \text{Number of Iterations in Goodness of Fit}$$

In proposed system,

The Number of Calculations = 1

**IV. Proposed Methodology**

GNG is a variant of self-organizing map which is responsible for learning the topological relations between the points in the dataset. It removes edges with ages above a certain value, effectively dropping the edges which become obsolete. If there are points in the map which do not have any edges connected to it, they are also dropped.

Here, the idea is to make use of growing neural gas as a tool to validate a regression model in order to minimize the number of iterations by the user as supposed in the existing methodology. It aims to utilize the topological relations between the points in the dataset instead of meticulous mathematical calculations being made at every step in the existing system. It can be achieved by -

- I. A neural gas running on the proposed algorithm learns the topology of the existent data.
- II. Once the model is trained, it is extracted and stored.
- III. Use the model to classify the predicted values from the linear regression model under a given cluster. If they belong to the same cluster as the previously existing data, the model fits perfectly.

For the dataset of 50 entries utilized for the experiment (given in table V.1) a GNG model is trained. Such a model will have learnt all the topological relations between the points in the dataset. The same dataset is utilized for training the existing regression model. Any point in the dataset will be reasonably close to the regression line if the model fits the dataset. Under such a situation, the number of clusters formed by the dataset is one. So, the growing neural gas model trained to the dataset will be able to account for the topological relations between any number of points utilized for testing. In other words, for testing, if for a test set 'X\_pred' and a predicted variable set 'y\_pred', the number of clusters formed by the GNG algorithm should remain equal to one. Any point which does not belong to the cluster lies too far from it and hence cannot fit the model trained as the topological distance between the predicted and the existing values is too high.

Irrespective of new data additions to the dataset, the model can be used without any further processing. The model has to be retrained only with the new data in order to improve accuracy.

**4.1 New suggested Goodness-of-Fit: Topological Fit: -**

The statistic model creates topological relations utilizing extensive mathematical calculations for understanding the inter-nodal topological relations. Utilizing a topological model eliminates the requirement for extensive mathematical calculations for understanding the same.

If, for a set of points, used to train a regression model, has a certain topological structure graphically and the total number of clusters is one, then for a test set consisting of points of same topological structure such that the total number of clusters remain one, fits the model reasonably.



**Graph Error! No text of specified style in document..1:** Plot of the dataset

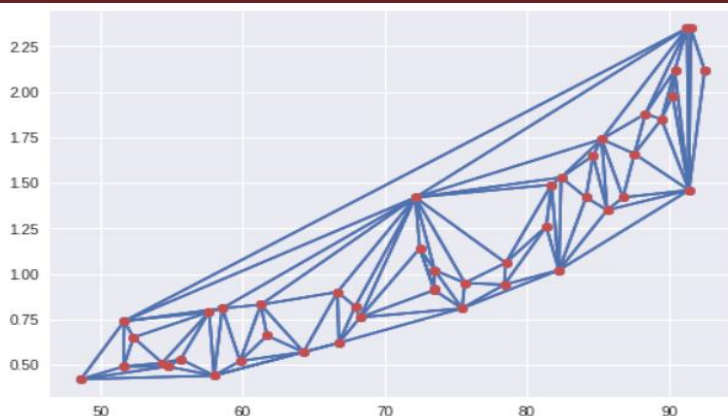

**Graph** Error! No text of specified style in document..2 : Inter-nodal structure of GNG for the corresponding dataset

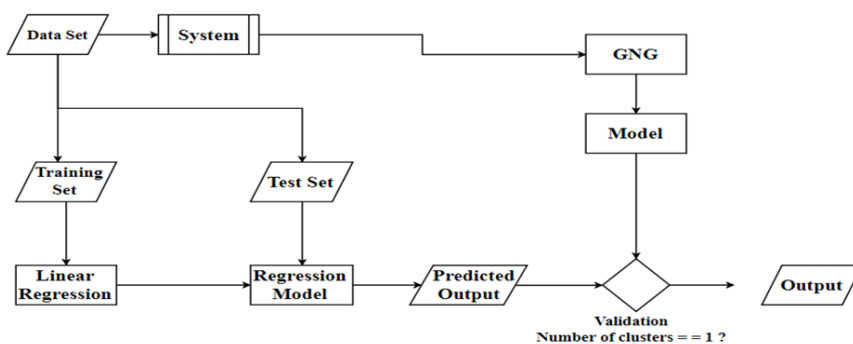

In the above graphs, Graph IV.1 displays the plot of the dataset. Graph IV.2 displays the structure of the trained GNG for the above dataset.

Any new point with a similar topology would belong to the same cluster and hence would fit the regression model reasonably.

#### 4.2 Program Flow

The programming involves understanding the requirement of vast amount of calculations for analyzing the data and forming patterns. This is achieved through usage of in-built python libraries such as numpy, which facilitates in handling large datasets. The dataset is stored in 'csv' file format due to it being portable on any device.

The flow of the program is as follows –

1. Installing the required modular toolkit for performing data processing.
2. Importing the “mdp” and “numpy” python libraries essential for performing immense mathematical operation.
3. Uploading the .csv file containing the dataset onto the cloud for validation.
4. Reading the uploaded .csv file using “pandas” library in python.
5. Training the data in order to facilitate validation for new nodes.
6. Extracting the weights and architecture of the trained model for further facilitation.

Fig. IV.1 represents the flowchart of the proposed system. The entire dataset is provided to the system, which trains a GNG that learns the topological relations and produces a model. As in the previous case, the dataset is divided into a training set and a test set. The training set is used to train the regression model. The test set is provided to the model provided by the regression algorithm. The predicted outcome provided by the regression model is given to the already trained GNG model. If the number of clusters remains one (after graphically plotting the new points along with the original set), the model produced by the regression model

fits the dataset reasonably. Here the GNG model is trained only once and utilized as many times as required. It does not need to be recalculated every time as in case of its precursors given in eqn 2 and 3.

**V. Results**

In order to verify the validation theory, a dataset of 50 entries and 2 parameters were supplied as inputs to both the existing regression validation process model and the proposed GNG Validation process model. The dataset was obtained from a First-Person-Shooter game consisting of average accuracy (AvgAcc, Eq. 4) and average kills to death ratio (AvgKD, Eq. 5) from 50 instances of certain player’s in-game statistics. This data was obtained from a beta version game designed by the authors.

Average accuracy is calculated as follows:

$$(4)$$

Similarly, average kill to death ratio is calculated as follows:

$$(5)$$

After passing the data set as input from Table V.1 to both existing validation process model and the proposed GNG validation process model, the following results were obtained. The results are showcased in Fig V.1 and Fig V.2. Both the models were run on the Google Colab hosted runtime with a GPU accelerator for the notebook.

```
CPU times: user 638 ms, sys: 4.04 ms, total: 642 ms
Wall time: 641 ms
```

**Fig. Error! No text of specified style in document..1 : Regression validation Run - Time (Existing)**

```
CPU times: user 44 μs, sys: 17 μs, total: 61 μs
Wall time: 65.1 μs
```

**Fig. Error! No text of specified style in document..2 : GNG Validation Run Time (Proposed)**

**Table Error! No text of specified style in document..1: Input Dataset**

S No.	AvgAcc	AvgKD	S No.	AvgAcc	AvgKD
1	66.66	0.9	26	82.24	1.02
2	73.5	1.02	27	80.16	1.13
3	84.15	1.42	28	86.75	1.42
4	91.4	1.46	29	84.65	1.65
5	62.9	0.86	30	89.52	1.69
6	67.9	0.82	31	91.48	1.92
7	68.25	0.76	32	92.5	2.12
8	61.26	0.83	33	90.25	1.98
9	51.65	0.74	34	91.26	2.35
10	57.62	0.79	35	90.4	2.12
11	58.55	0.81	36	89.46	1.85
12	52.3	0.65	37	72.14	1.42
13	55.62	0.53	38	75.62	0.95
14	64.27	0.57	39	73.45	0.92
15	48.6	0.42	40	78.5	1.06



16	51.6	0.49	41	72.45	1.14
17	54.32	0.51	42	81.35	1.26
18	57.98	0.44	43	85.64	1.35
19	54.7	0.49	44	81.72	1.49
20	59.8	0.52	45	82.4	1.53
21	61.7	0.66	46	88.33	1.88
22	66.75	0.62	47	91.52	2.35
23	75.42	0.81	48	87.56	1.66
24	78.4	0.94	49	85.25	1.74
25	73.46	0.91	50	82.24	1.02

## VI. Discussion

The total run time for the existing regression validation (Fig V.1) was found out to be 642 milliseconds. On the other hand, the total run time of the GNG validation (Fig V.2) was found out to be 61 microseconds which makes the proposed process  $10^4$  times faster than the existing process.

"The Pearson Goodness-of-Fit statistic and the deviance statistic" rely heavily on the dataset and are prone to change over time with an incremental dataset. The proposed system, however eliminates this requirement altogether by relying on topological relations instead of the dataset. All parameters are constant over time. In addition, in case of a neural network, every epoch entails a new batch of data generated from the same dataset which introduces a new randomness factor which in turn creates an additional requirement for processing.

This requirement is also eliminated by relying on topological relations instead. However, the process of training a "growing neural gas" to the present dataset to learn the topological relations does add a processing overhead which does, in the long run turn out to be more optimized than the repeated calculation of the statistic.

## VII. Conclusion & Future Scope

An experiment was conducted to verify the validity of the proposed theory by comparing the experimental runtime of both the proposed system and the existing system. It was found out that the proposed system was faster than its existing counterpart by a factor of  $10^4$ .

It is also theorized that the runtime of the proposed system remains constant irrespective of the change in the number of epochs or the batch size. Due to computational constraints, a small dataset was utilized for the verification of the theory. The same theory can be verified in the future with a significantly larger dataset when these constraints are addressed.

Since, the study of neural network has not yet reached a level of saturation, there are many more possibilities of them replacing the conventional methods currently trending in the field of machine learning. Also, neural network is still considered a black box, and hence what happens inside it is unknown. Because of this, it is not possible to explain the constituents of this ideology completely.

When it becomes possible to know what happens inside a neural network, there is a possibility of improving the currently proposed system with the aid of then existing contemporary technologies.

## VIII. References

1. Angora G., Brescia M., Cavuoti S., Riccio G., Paolillo M., Puzia T.H. (2018) Neural Gas Based Classification of Globular Clusters. In: Kalinichenko L., Manolopoulos Y., Malkov O., Skvortsov N., Stupnikov S., Sukhomlin V. (eds) Data Analytics and Management in Data Intensive Domains. DAMDID/RCDL 2017. Communications in Computer and Information Science, vol 822. Springer, Cham.
2. Bernd Fritzke. 1994. A growing neural gas network learns topologies. In Proceedings of the 7th International Conference on Neural Information Processing Systems (NIPS'94), Gerald Tesauro, David S. Touretzky, and Todd K. Leen (Eds.). MIT Press, Cambridge, MA, USA,625-632.
3. Ronald D. Snee. 1977. Validation of Regression Models: Methods and Examples, *Technometrics*, 19:4,415-428.
4. Rebecca E. Morrison, Corey M. Bryant, Gabriel Terejanu, Serge Prudhomme, and Kenji Miki. 2013. Data partition methodology for validation of predictive models. *Comput. Math.Appl.* 66, 10 (December 2013), 2114-2125.DOI=<http://dx.doi.org/10.1016/j.camwa.2013.09.006>.
5. 2.4-Goodness-of-Fit Test. <https://newonlinecourses.science.psu.edu/stat504/node/60/wwws>

## Fractional Ownership in Agriculture using Blockchain

**Dhanyakumar Baid, Gurkeerat Singh, Nikhil Raj and K Meenakshi**

<sup>1,2,3</sup>Dept. of Computer Science, SRM Institute of Science and Technology, Bangalore, India

<sup>4</sup>Assistant Professor, SRM Institute of Science and Technology, Bangalore, India

---

**ABSTRACT:** Agriculture is one field that requires a heavy technological advancement in order to sort day to day processes like ploughing, seeding and harvesting. The main reason why this was not possible was because of the absence of trust between the necessary entities. Blockchain tends to solve this problem. Digitisation of land can be done by blockchain. It not only gives us a way to store the lands, it also gives us the option to keep a track of the changes. There might be a possibility of one farmer not being able to afford one tractor, harvester and a seeder, but it is possible for say 10 farmers to do the same. Blockchain solves the problem with the help of shared provenance. Therefore, with the help of digitisation of land, fractional ownership, smart contracts and shared provenance, we can definitely help the agriculture sector immensely.

**Keywords:** Blockchain, Fractional Ownership, Shared Provenance.

---

### 1. Introduction

Digitization through blockchain is a very eloquent way to approach this problem. It not only gives us a way to store the lands, it also gives us the option to keep a track of the changes. It can also be an opportunity to treat n number of smaller lands as one large entity and the necessary calculations can be done with the help of smart contracts. This gives rise to the concept of fractional ownership, which might be very helpful in this case. Current technologies like cloud and other databases can be easily tampered with. They pose to be extremely vulnerable to not only internal attacks but external attacks alike. Hence, while dealing with sensitive data much like the land records, there needs to be a technology that guarantees trust. Blockchain is one such idea which helps in storing the data in the most secure way possible. With the data being distributed over the network and ledgers which are maintained by all peers in the network, it is almost impossible to tamper with the data without triggering a chain reaction of each peer reviewing their ledgers. And when any discrepancy is found while maintaining the said ledgers, it is found that the data was tampered with and the node is backtracked. After which normalcy is restored in the network. Such a feature could be of great help to this cause as here, one can not only see who the land belongs to but also who the land belonged to.

The other aspect of this paper is Fractional Ownership. Farmers in India have been taking their lives because the non-payment of their loans. They definitely cannot afford the luxuries of tractors or seeders as an individual. However, they can afford it if a group of farmers pitch in together. But the lack of trust among themselves and the complex calculations make it very difficult to make it a reality. This is where FracO comes in. FracO is a system that lets users to register their lands without any hassle and lets them create fractional ownerships of physical entities like a tractor, seeder or fertilisers. With blockchain as the base, it gives credibility and trust to the system.

### II. Existing Systems

This is an extremely unique system which is currently not in existence. The concept of fractional ownership in agriculture doesn't exist. The closest system existing in this field is the digitisation of lands that is taking place in Andhra Pradesh. Andhra Pradesh, in its newly planned capital Amravati has been using blockchain for land acquisition and land registration. The new system reduces middle men and makes the entire process transparent. There is no need to have a document writer to get the legal documents done as it is automatically taken care of by the system.

The system collects 58 attributes like Aadhar card, latitude, longitude, survey number, etc. to ensure that there is no confusion as far as the land and its ownership is concerned. It has been using a private blockchain which is then connected to a local cloud. Hence it is a hybrid of the two technologies. The results show that this outperforms the existing methods as it has the protection of blockchain. It issues necessary certificates with the help of the blockchain to validate the land and its owner.

### III. Problems and Inference

While this has been a significant development in this area, there are a few drawbacks of this system. Since it is also using the cloud for some of its iterations, it possesses a threat to the security of the entire system. However, this is still an eloquent way to move forward as far as the digitisation of land is concerned. It does not have the option of fractional ownership for farmers or anyone for that matter.

### IV. Proposed Solution

Blockchain is a very eloquent way to approach this problem. Digitization of land can be done by blockchain. It not only gives us a way to store the lands, it also gives us the option to keep a track of the changes. Hence, we can not only see who the land belongs to, but we can also see who the land belonged to. This will ensure that the property thefts and frauds are drastically reduced if not brought to an end.

### V. Review of Literature

#### Bitcoin: A Peer-to-Peer Electronic Cash System

**Author: Satoshi Nakamoto**

**Description:** An idea to transfer digital money from one person to another without the involvement of a third-party institution as a middle man. There is still a need for digital signature but the whole point is lost if there is still a requirement of a third-party involvement.

**Methodology:** To tackle this, this paper puts forward a peer-to-peer network which uses evidence of-work to log an open history of exchanges which turns out to be computationally impossible for an attacker to change all the legitimate nodes in that peer to peer network. The system is unstructured while being straightforward where the nodes do not require much co-ordination to work. They only need to be steered on a best effort basis.

**Challenges:** The volatile nature of any cryptocurrency is of a huge issue.

#### Towards Shared Ownership in the Cloud

**Author: Hubert Ritzdorf, Claudio Soriente, Ghassan O. Karame, Srdjan Marinovic, Damian Gruber, Srdjan Capkun**

**Description:** This paper mainly discusses the premise of access control of shared ownership in cloud storage platforms. The access control works by maintaining a record of all the requests in a shared vault. The access is granted only if a majority of owners grant the access. Therefore, the paper presents a model of shared ownership with access control.

**Methodology:** The paper proposes a new methodology which is called Comrade. It works in tandem with the cloud platform that is needed to decipher the access control. This new method works much better than the previously proposed Commune. Comrade works on the Ethereum blockchain and works with Amazon Cloud platform.

**Challenges:** Cost and complexity of integrating blockchain with cloud is very high.

#### Design of the Blockchain Smart Contract: A Use Case for Real Estate

**Author: Ioannis Karamitsos, Maria Papadaki and Nedaa Baker Al Barghuthi**

**Description:** Globally speaking, land has a really important role to play in the development of smart cities. Smart cities are basically those metropolitan areas which have a proper network and other communication services incorporated into the initial planning phase of the same. Such networks not only enhance the standard of living but also contribute to sustainable development.

**Methodology:** It uses the concept of smart contracts which are indigenously present in the Ethereum blockchain. The steps to define any smart contract include setup of nodes on the blockchain, defining the clauses on which the smart contract work and the necessary computations between users are portrayed.

**Challenges:** A "51%" attack is still possible where an attacker has the control over the majority of the devices on the network.

### VI. Proposed Framework

#### 1. Login and Register using Blockchain

With the increased cases of identity theft and data leaks all around the world, authentication is a major concern.

The use of blockchain technology is at a very early stage right now, but it is increasing at a rapid pace. The blockchain is useful in many sectors like retail, banking, voting, insurance etc. One such aspect is the use of

blockchain as an authentication provider. Blockchain works on the basis of key-pair values that are stored in the form of hashes when the user registers the identity. Several parameters will be required while creating the aforementioned key-pair value. In FracO, we would be using blockchain for authentication purpose and the whole login verification would be based on the verification of hashes by authenticating that the information provided on the blockchain is true. Authentication documents such as Aadhar Card number and Kisaan ID among others will be taken in for verification.

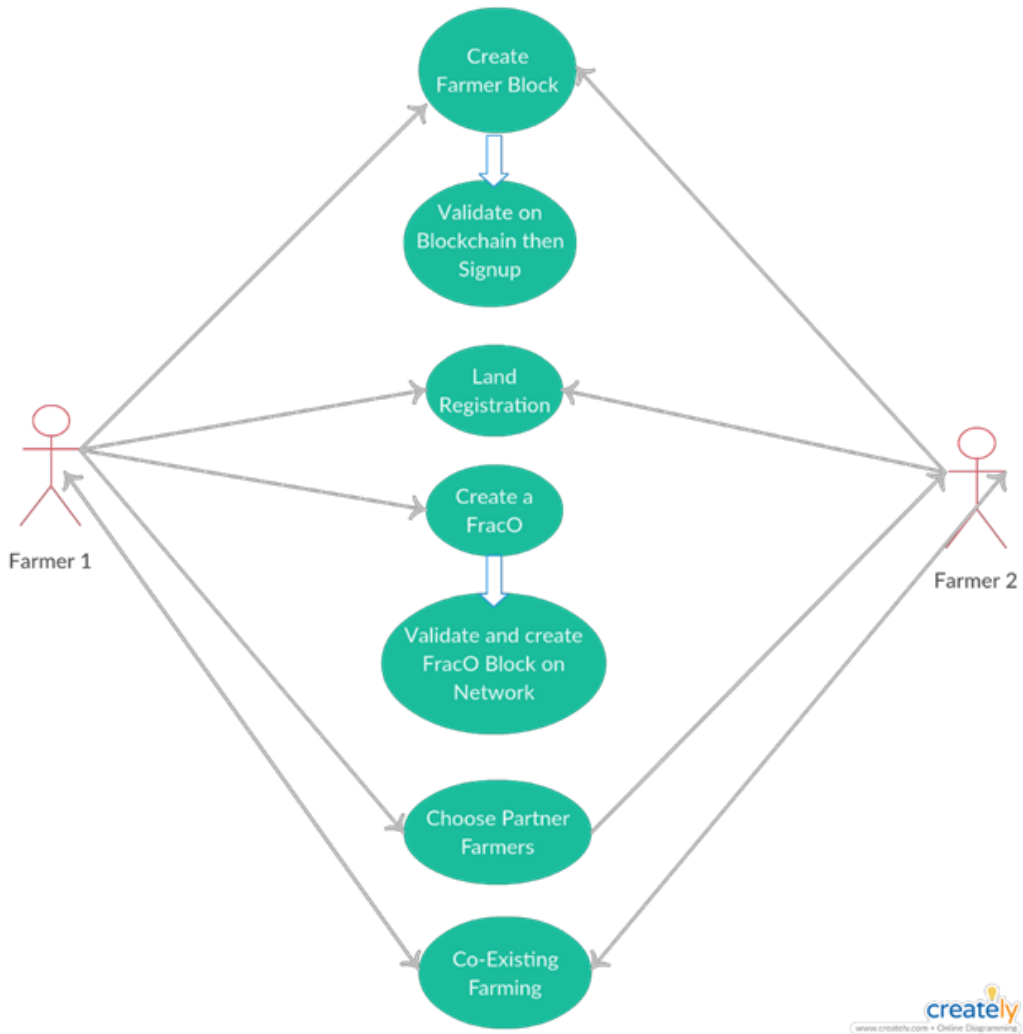

Fig 1: Use case diagram

## 2. Ethereum asset tracking, management & bookkeeping

A visual dashboard will be created so that the user can monitor activities throughout the account at one place. It will be consisting of the existing fractional ownership that are active for the user, all the shared resources and their dynamic calculations will be displayed. It will also enable the user to create a new shared provenience for either land or other farm resources. In short, it will act as a Ethereum asset tracking, management & bookkeeping for the users.

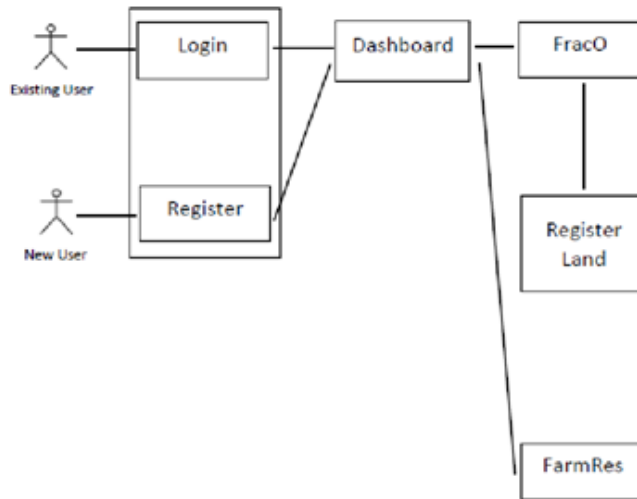

Fig 2: Architecture Diagram

### 3. FracO Creation

The main idea behind creating a FracO is to tokenize a physical good like land and issue a digital asset on a blockchain network that stands in as that thing's digital counterpart.

Fractional ownership takes the logic of tokenization a step further. In most blockchain networks, tokens are divisible. Therefore, even if a token represents an indivisible physical asset, like a house, the digital representation of ownership over that asset can be divided into parts and sold to several owners.

A lot of pieces will fall into place to make a collective fractional ownership system implemented in a practical way and we call each token of this Fractional Ownership as a FracO

### 4. FracO Management for Co-farming

The primary objective of creating a FracO is to promote the concept of Co-Farming. Co-Farming is a form of social farming where people share spatial and financial resources to make their livelihoods more affordable and community-oriented. By promoting density and shared property ownership, co-farming can also be more environmentally sustainable than other forms of commodity farming. So, to do that a FracO will enable the user to manage or terminate a new Shared Ownership at any time and thus maximize his efficiency for farming.

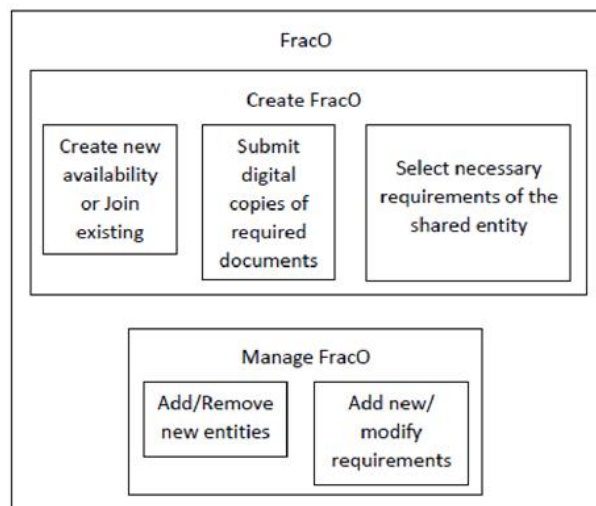

Fig 3: FracO Flow

## 5. Land Registration

Blockchain in the field of real estate has immense potential. To elucidate the same, one needs to understand how

property is being dealt with today. One needs to have the title deed and the lawful owner to sign it over. Then begins the entire tedious procedure of having different government offices involved for the verification. Due to the lack of communication between those departments, the frauds take place.

FracO aims to end such frauds by verifying hashes for every transaction that takes place. To make the entire system more transparent, the records will be publicly available and searchable while showing the history of transactions that have taken place. A certain number of documents will be taken before the land is shifted to the blockchain which would enable to verify us the ownership.

## Figures and Tables

Figure number	Figure Name
1	Use case Diagram
2	Architecture Diagram
3	FracO Flow

## VI. Acknowledgment

We would like to thank Mr. Jasprit Bindra from Tech Mahindra for inspiring us with his TEDx talk. We would also extend our heartfelt gratitude to our project co-ordinator Mrs. Latha S for her continuous support.

## References

1. Satoshi Nakamoto, Bitcoin: A Peer-to-Peer Electronic Cash System
2. Hubert Ritzdorf, Claudio Soriente, Ghassan O. Karame, Srdjan Marinovic, Damian Gruber, Srdjan Capkunk. Towards Shared Ownership in the Cloud
3. Ioannis Karamitsos, Maria Papadaki and Nedaa Baker Al Barghuthi. Design of the Blockchain Smart Contract: A Use Case for Real Estate
4. Meghna Bal. Securing Property Rights in India through Distributed Ledger Technology
5. Deloitte, Blockchain in commercial real estate
6. REINFORCING THE LINKS OF THE BLOCKCHAIN November 2017 - IEEE, Morgen Peck, Freelance Technology Writer,
7. Contributing Editor of IEEE Spectrum Magazine Special Edition "Blockchain World"
8. Introduction to Security and Privacy on the Blockchain: Harry Halpin, Marta Piekarska
9. Blockchain-based trusted computing in social network-2016 2nd IEEE International Conference on Computer and Communications (ICCC)
10. Blockchain technology, bitcoin, and Ethereum: A brief overview, Dejan Vujičić, Dijana Jagodić, Siniša Randić [10] Beyond
11. Bitcoin: The Rise of Blockchain World, Roman Beck

---

# Prediction of Heart Valve Disorders using CNN and DTW Based CBR

**Aarathi K**

M.Tech -IT

College Of Engineering, Guindy

Anna University, Chennai, Tamil Nadu, India

---

**ABSTRACT:** *The proposed work entails the diagnosis of various pathological heart valve disorders by analyzing the heart sounds. The main aim of the system is to develop an algorithm that will allow existing methods of computer aided auscultation to work in real time so that they can be used in patient monitoring. The framework starts with data acquisition methodology, where in the heart sound signals are captured using stethoscope via microphone. Then the heart sounds are preprocessed to remove the unwanted noise. The processed signal is segmented by taking homomorphic envelope of the signal for which hilbert transform is done. Then the peaks are identified for the segmented signal. The features are extracted using Short Time Fourier Transform (STFT). Similar sounds in the gallery can be obtained using Dynamic Time Warping (DTW) and it can be used for future work for case based reasoning. The features are then given to Convolutional Neural Network (CNN) as supervised learning.*

**Keywords:** *STFT, CNN, DTW, homomorphic envelope.*

---

## 1. Introduction

Cardio Vascular Diseases (CVDs) remains the major cause of death throughout the world. Auscultation of Heart Sound (HS) signals plays a vital role in CVDs early prevention and detection. Listening to HS with an acoustic stethoscope, provides cost-effective approach to inspect the abnormality of HS signals with pathological CVDs symptoms. Thus efficient diagnosis of cardiac diseases has become very important. The number of deaths caused by cardiac diseases is expected to reach 23.3 million by 2030. Cardiac auscultation is the basic tool to classify the normal and abnormal sounds. The significance of the auscultation has led to the automation of the classification of pathological heart sounds. The system despite its medical significance, is relatively an unexplored area of application for machine learning and entails the functions to detect the heart disease and decides whether the patient require any special care or not.

## II. Proposed System

The heart sound classification system deals with the classification of various pathological heart sounds. Stenosis and Regurgitation are the common problems in heart valve. High percentages of patients those who have benign heart sounds are referred to cardiologists for evaluation. So a computer assisted system can help the general physician in coming up to a more accurate and reliable diagnosis at early stages. It can reduce unnecessary referrals of patients to expert cardiologists at a distant. The sound files are preprocessed first to remove the noise and to make the sound adjusted to audible range. It is followed by signal segmentation, wherein the heart sounds S3, S4 are detected using peak detection of hilbert envelope [2]. The features are then extracted from signals using STFT. Using the features the similar sounds identified using DTW. Then the system classifies the various heart valve disorders with heart sound using CNN [8]. The design of the system includes the five main steps that helps in segmenting and classifying various pathological heart sounds.

### A. System Architecture

The proposed work entails the human heart sound classification which might find use in cardiac disease diagnosis. The Figure 1 entails the process and various modules involved in the proposed system of "Prediction of heart valve disorders by using CNN". The system involves classification with CNN in order obtain good accuracy in classifying the pathological heart sounds. All the processing are done in Matlab. The figures mentioned in the papers are processed by the Matlab program.



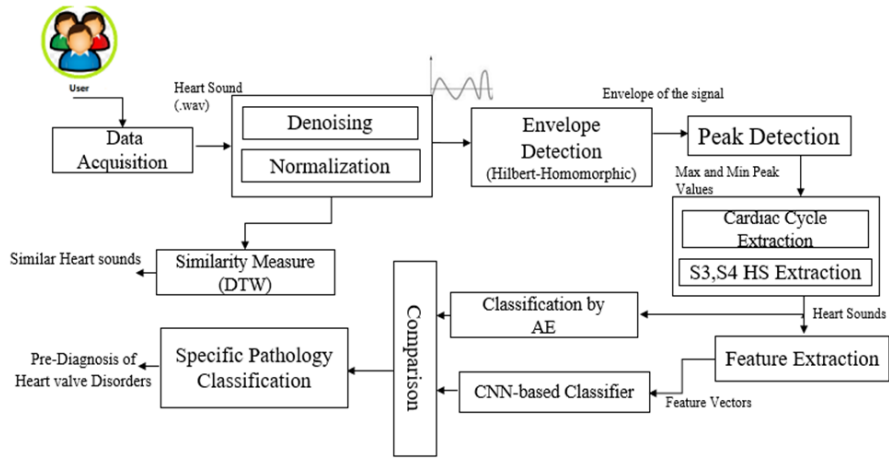

4

Figure 1: Prediction of heart valve disorders by using CNN”

**B. Pre-Processing and Segmentation**

The preprocessing is done to remove the unwanted noise that has been added to the original sound. The Figure 2.a depicts the preprocessed signal and from the original signal and then the segmentation is done using homomorphic and hilbert envelope [5]. The Figure 2.b and Figure 2.c entails the segmentation and peak detection part.

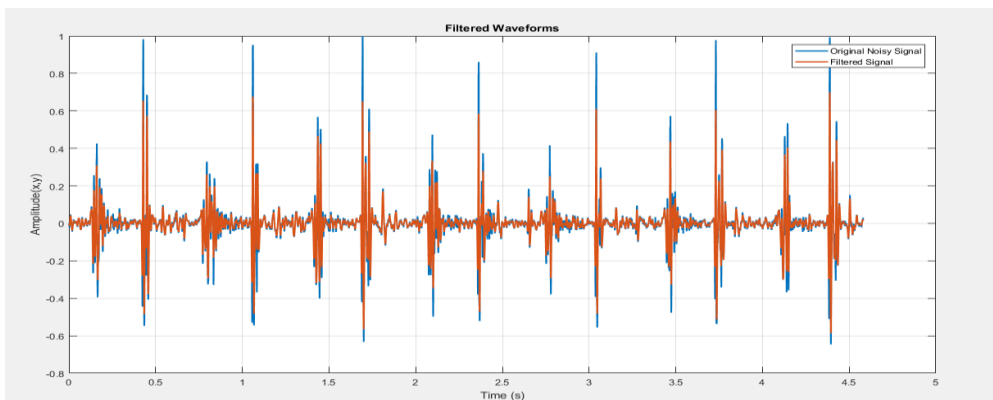

Figure 2.a: Preprocessed Signal

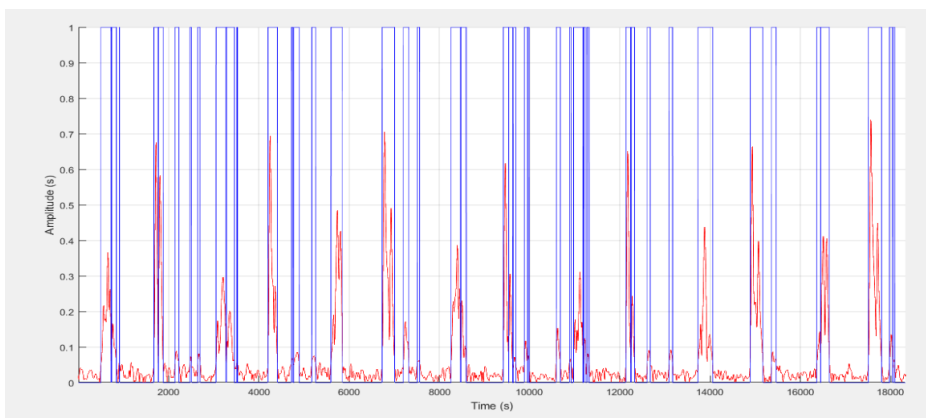

Figure 2.b: Homomorphic Envelope with Segmentation

### C. Peak Detection

The signal has both positive and negative components. In order to eliminate the negative components of the signal the hilbert transform is applied. Analytical signal obtained after transformation is applied with homomorphic envelope to avoid distortions. From the envelope the peaks are determined. The most dominant peaks are retrieved. Whereas the other remaining peaks are rejected or eliminated as in [2] and the intervals of HS are detected. Cardiac cycle is calculated for the signal using average distance between the neighboring peaks.

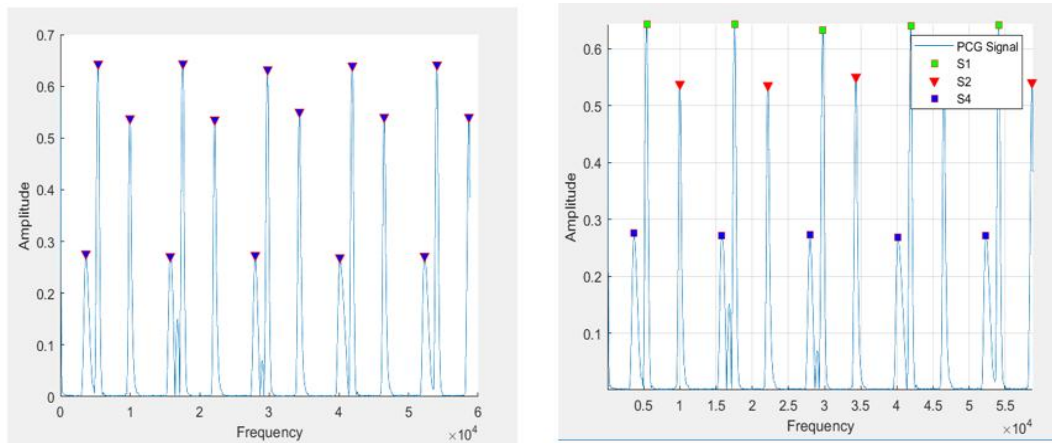

Figure 2.c: Peak Detection

### D. Feature Extraction using STFT

Feature extraction is the important step in detection and classification of heart diseases. It is a challenging task to extract a set of good features from PCG signals for classification. The time-frequency domain are obtained using STFT which is used to obtain the spectrogram of the signal by performing successive fast fourier transform on the framed signal. The Figure 2.d entails the spectrogram image of the signal. The procedure for computing STFTs is to divide a longer time signal into shorter segments of equal length and then compute the Fourier transform separately on each shorter segment. This reveals the Fourier spectrum on each shorter segment. Hence the changing spectra as a function of time is obtained using STFT.

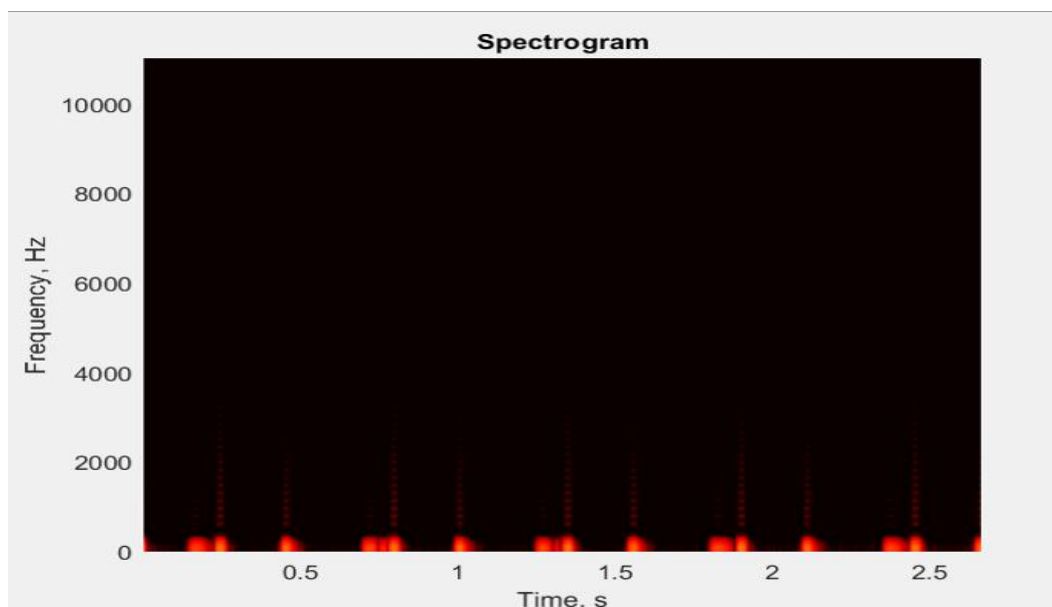

Figure 2.d: Spectrogram

**E. Classification using CNN**

Convolutional Neural Network is a popular classification system used for image classification [8]. The system is trained with the spectrogram images of 500 x 700 pixels. Then the test audio file is given and its spectrogram is obtained and it is compared against the trained network to predict the class label. Convolutional Layer, Pooling Layer, and Fully-Connected Layer are the three layers build up the architecture. The Figure 2.e describes the training process involved under CNN.

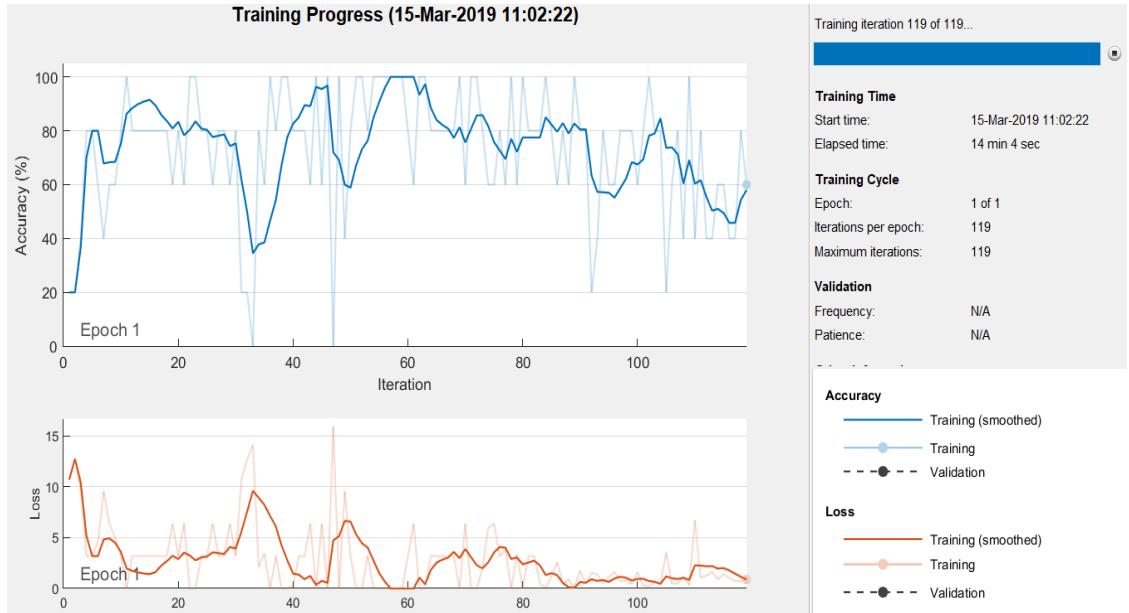

Figure 2.e: Training process of CNN.

**III. Similar Sound Identification using DTW**

The system involves similar sound identification. The similar sounds are identified by applying Dynamic Time Warping (DTW). It evolves by identifying matching sequences and comparing them. In time series analysis DTW is one of the algorithms for measuring similarity between two temporal sequences, which may vary in speed. Since heart sounds are nonstationary signals, DTW is helpful in identifying the similarity. The input sound is loaded and then DTW is applied to it and the remaining files in the directory where the sounds are stored. The DTW provides the list of audio files which are similar to the input sound from the directory of files. The class labels for the audio files in the directory are already defined. The class labels for the similar sounds are retrieved and mode of the values are taken to get the maximum repeated value of the labels. The value is set as the output indicating that the input audio file also has the same class label. Thus the system can be enhanced to be used in the case based reasoning. Following is the algorithmic steps to calculate DTW.

**Algorithm:** Similar Sound Identification using DTW

**Input:** Audio Signal.

**Output:** List of Similar Audio Files.

```

1: Initialize the matrix.
   x[0,0]=0
2: for length of the signals do
3:   x[i,i]=0;
4: end for
5: for the length of the sequences(i,j) do
6:   calculate the cost
7:   S=min(cost(i),cost(j));
8: end for
9: To find the best match or alignment between the two sequences, the path
   through the grid which minimizes the total distance between the two
   sequence is found.
    
```

DTW applies the grid and it involves identifying the best path through the grid which minimizes the total distance. Likewise it calculates the distance between the other sequences. This case study can be used for predicting the heart valve disorders for the given audio by finding the similar files in the gallery and calculating the central tendency.

**IV. Result**

The confusion matrix is plotted for the trained set and the tested set. A confusion matrix is a table that is often used to describe the performance of a classification model on a set of test data for which the true values are known. The Figure 3 describes the confusion matrix for the system trained under CNN. The system takes three classes of abnormalities namely AS (Aortic Stenosis), MS (Mitral Stenosis) and MR (Mitral Regurgitation). The dataset used for the system consists of 200 audio files in each category. The Accuracy obtained is 95.3%. The Figure 4 gives the performance analysis of the system. It describes the matrix for each class labels with their TPR and TNR values. It contains the accuracy, sensitivity, precision, recall, f\_score value for each classes. The F\_Score is calculated as:  $2*((precision*recall)/(precision+recall))$ .

	AS	MR	MS	N	
AS	14 16.5%	3 3.5%	0 0.0%	0 0.0%	82.4% 17.6%
MR	1 1.2%	33 38.8%	0 0.0%	0 0.0%	97.1% 2.9%
MS	0 0.0%	0 0.0%	14 16.5%	0 0.0%	100% 0.0%
N	0 0.0%	0 0.0%	0 0.0%	20 23.5%	100% 0.0%
	93.3% 6.7%	91.7% 8.3%	100% 0.0%	100% 0.0%	95.3% 4.7%
	AS	MR	MS	N	

Figure 3: Confusion Matrix

Method	Classes	Accuracy	Sensitivity	Specificity	Precision	Recall	F_Measure	Gmean
CNN	AS	0.95	0.93	0.95	0.82	0.93	0.87	0.94
	MR	0.95	0.91	0.97	0.97	0.91	0.94	0.94
	MS	0.95	1	0.94	0.77	1	0.87	0.97
	N	0.95	1	0.93	0.83	1	0.9	0.96

Figure 4: Performance Analysis

The system achieves accuracy of 95% using CNN. Thus the proposed system can be used to provide the valuable suggestion to physicians and doctors about the various type of heart valve disorders.

### V. Conclusion

Thus the system classifies the pathological heart sounds using neural network. The system achieves accuracy of 95%. To summarize, the system analyses the input heart sound and provides the valuable suggestion to the physicians and doctors about the various type of heart valve disorders. Thus the proposed system is found useful in cardiac disease prediagnosis. The future work of this system is to further strengthen the accuracy of the proposed scheme. Identification of heart rate variability features which could improve the classification accuracy. To further classify the subtypes in the heart valve disorders by analyzing the heart sounds.

### VI. References

1. Abhijit Verma, Abhishek Attal, Khalid Badi-uz-zama, "Electronic Stethoscope: Sound Extraction, Processing and Analysis", International Journal of Engineering and Technical Research, Vol.4, No.6, 2015
2. Amy H. Salman, Nur Ahmadi, Richard Mengko, Armein Z. R. Langi, Tati L. R. Mengko, "Automatic Segmentation and Detection of Heart Sound Components S1, S2, S3 and S4", International Conference on Instrumentation, Communications, Information Technology, and Biomedical Engineering, pp.103-107, 2015.
3. Anatoly Yakovlev, Vincent Lee, "Application of Machine Learning Techniques for Heart Sound Recording Classification". Stanford University: Computer Science course on Advances in Machine Learning (CS229), 2017.
4. Anjali Yadav, Malay Kishore Dutta, Carlos M Travieso, Jesus B. Alonso, "Automatic Classification of Normal and Abnormal PCG recording Heart Sound Recording Using Fourier Transform", IEEE International Work Conference on Bioinspired Intelligence, pp.1-9, 2018.
5. Ashraf Shamseldin Yahia, El-Sayed Ahmed El-Dahshan, Mohamed Nabih. "A Review of Intelligent Systems for Heart Sound Signal Analysis", in the transactions of Journal of Medical Engineering and Technology, Vol.41, No.7, pp.1-11, 2017.
6. Cristhian Potes, Saman Parvaneh, Asif Rahman, Bryan Conroy, "Ensemble of Feature-based and Deep Learning-based Classifiers for Detection of Abnormal Heart Sounds". PhysioNet-Computing in Cardiology Conference (CinC), pp.621-624, 2016.
7. Imran Mohammad Sofi, Mohd Azlan Abu, Mohd Syazwan Md Yid, Mohd Zubir Suboh, Muhyi Yaakop. "Heart Valve Disease Screening System-PC based", in the proceedings of International Conference on Engineering Technology and Technopreneurship, pp.1-4, 2017.
8. Tien-En Chen, Shih-I Yang, Li-Ting Ho, Kun-Hsi Tsai, Yu-Hsuan Chen, "S1 and S2 Heart Sound Recognition using Deep Neural Networks", IEEE Transactions on Biomedical Engineering, vol.64, No.2, pp.372-380, 2017.

# Privacy Protection for P2P Decentralized Network Using Blockchain For Data Privacy by Implementing Multiple Databases

K Meenakshi, Arun Prasad K, Vivek Subramaniam, Prasad Durga

SRM Institute of Science and Technology

Bangalore, India

**ABSTRACT:** Peer to Peer network with decentralized servers are the fastest growing technology in terms of robustness and efficiency, a pure decentralized p2p network is however adequate in securing data, it has its own flaws and leaks in its conventional system. In this paper we propose a P2P Decentralized network scheme which will give more robust and increased privacy protection of user's data, preventing them from masquerading and sniffing of the data from obscure people who intend to damage or modify the stored data. As the conventional p2p scheme is secured ,still it can be traced by using the same blockchain towards its owner ,which makes the network vulnerable we are going to tackle the lack of security by removing relay nodes from the equation and implementing DIFF algorithm for modifying data which is an easy way to modify the stored data compared to previous conventional method of modifying the stored data, and the user can cut the transmission cost by choosing the closest node based on the updating frequency . The main advantage of the proposed scheme is by implementing multiple database and storing the encrypted file at a different database and encrypted key in different database can make the people who tries to sniff the file to make fail by storing them at different places.

**Keywords:** P2P, DIFF, Security,Blockchain,Data Privacy

## 1. Introduction

In a P2P organize, the client uses and gives the establishment of the system in the meantime, despite the fact that giving the assets is completely intentional. Each companion (a peer being a PC framework on the system) is viewed as equivalent and are regularly alluded to as hubs. A friend makes a segment of figuring assets, for example, plate stockpiling, preparing force or system data transfer capacity, straightforwardly accessible to different members without the requirement for any focal coordination by servers or stable hosts. Notwithstanding all hubs being equivalent, they can take on various jobs inside the blockchain biological community, for example, that of a digger or a full node. On account of a full hub, the entire blockchain is replicated onto a solitary gadget, while the gadget is associated with the system. This means the data put away on a blockchain can't be lost or demolished in light of the fact that to do as such would mean wrecking each and every full hub on the system. In this way, up to a solitary hub with a duplicate of a blockchain exists, every one of the records will stay unblemished, giving the likelihood to modify that organize.. As P2P is secured it still haveits flaws and retraceable to its owner so that a person can identify the data owner which makes the data owner at risk. As the transmission cost is higher and delay in fetching which can be reduced using different scheme of selecting storage node in a p2p network and modification of data still needs a complete set of modified data along the original data needed to be sent to storage node in order to modify the intended data , we can overcome this by introducing an different set of algorithm so that transmission cost and time delay will be lesser, the privacy protection by implementing relay nodes will be leading to complete control of the data to relay node which will lead to take ownership of data which is quite unsecure.

## 2. Literature Survey

From [1] we can understand Data is the building square of Information Centric Networks (ICNs). Access control arrangements limit data spread to approved elements as it were. Denying access control strategies in an ICN is a non-unimportant assignment as a data thing may exist in different duplicates scattered in different system areas, including stores and substance replication servers .This undertaking propose an entrance control requirement designation conspire which empowers the purveyor of a data thing to assess a demand against an entrance control arrangement[2]. Such a methodology has different benefits: it empowers the interoperability of different partners, it secures client personality and it can set the reason for a protection safeguarding instrument. A usage of our plan underpins its achievability. This [6] reference makes us to understand how important an access control will be acting in an network area in order to keep it secure.The another major Maidsafe architecture[7] gave birth to our architecture as The development of decentralized cryptographic forms of money, for example, Bitcoin and the achievement of the anonymizing

system TOR lead to an expanded enthusiasm for distributed based innovations recently – not just because of the predominant organization of mass system reconnaissance advancements by specialists around the world. While the present application benefits normally utilize concentrated customer/server structures that require the client to confide in the specialist co-op, new decentralized stages that dispose of this need of trust are on their ascent. This venture fundamentally examine a completely decentralized option in contrast to the present advanced biological system – MaidSafe – that drops the majority of the ordinarily connected standards. The MaidSafe organize executes a completely decentralized individual information stockpiling stage on which client applications can be fabricated as mentioned. The system is made up by individual clients who contribute capacity, processing force and data transfer capacity. All correspondence between system hubs is scrambled, yet clients just need to recollect a username and secret key. To ensure these destinations, MaidSafe consolidates instruments, for example, Self-Authentication, Self-Encryption, and a P2P-based open key framework. This venture gives a consolidated depiction of MaidSafe's key convention instruments[3], infers the basic personality and access the executives design, and assesses it regarding security and protection angles. The customary decentralized accessibility based replication calculations experience the ill effects of high reliance on the under-lying framework's stir conduct, haphazardness in reproduction choice, and the failure of boosting the copies accessibility. These downsides result in poor information accessibility particularly in low benefit capable frameworks just as where the agitate conduct is mispredicted. This task propose dynamic, completely decentralized accessibility mindful calculation named Awake, with the objective of boosting the accessibility of copies. Contrasted with the current arrangements, Awake dependably gives the most extreme accessibility of copies paying little respect to the basic framework's stir conduct. By utilizing Awake[8], an information proprietor can choose its reproductions just dependent on the totaled accessibility data of hubs got in a completely decentralized way with asymptotically a similar message overhead as the correspondence multifaceted nature of the fundamental framework. Alert has straight space multifaceted nature in the quantity of enlisted clients to the framework[5]. The broad reproduction results demonstrate that in contrast with the best existing decentralized arrangements, paying little heed to the hidden beat model of the framework, Awake improves the accessibility of copies with an addition of about 21%. In like manner, Awake is adaptable by appearing same execution free of the framework estimate. This gives us the schematic idea of how to enhance the architecture in future era.

### **3. Objective of the proposed work**

The main objective of this scheme is to provide security of user's data in a p2p network from obscure people who try to damage the data by using multiple databases in a p2p network and we try to give the user's permission to modify or download the data so that it is more secure and traceable.

#### **3.1 Existing System**

The existing p2p network consists of large storage nodes consists of data which will make the transmission cost higher, the existing scheme consists of a large process of modifying data that is to send all the data including modified data to storage node to modify data which makes this a long cost process and for privacy protection the existing system uses relay nodes which takes ownership of the complete data instead of user which makes the data in risk.

#### **3.2 Proposed system**

The proposed system uses selection of closest storage using frequently updated nodes which makes the transmission cost lower , we are going to implement DIFF algorithm for modifying data and we are going to implement multiple databases for privacy protection

##### **i) Selection of closest storage node :**

The major concept behind this is to reduce the transmission cost used by user in a p2p network , here we propose an idea of selecting the storage node based on the closest node , the user can set the updating frequency of the data and policy of updating frequency, and user can follow the updated policy. As the data frequency is high it will be stored in closest storage node if it is low data will be stored in distant node.

##### **ii) Modification of the data with low cost:**

In the regular plan, the client needs to get all of the put away information from the capacity hubs for adjustment furthermore, resends the adjusted information to store. This causes the high correspondence



cost because of the trading information in the system. Then again, in the proposed plan the client can viably alter the put away information with the low correspondence cost through DIFF techniques. We accept that A is the first one, B is the adjusted information, C is the put away information in the capacity hubs, and D is DIFF which is the contrast among A and B. By DIFF strategies, subsequent to creating B the client makes D among A and B and sends D to the capacity hubs to alter C. The quantity of D as same as the quantity of C.

iii) Protection of user's privacy:

We remove the proposed concept of relay nodes as relay nodes take over the user in a P2P network , we install the user's approval for authentication and downloading the data from an specified user and the implementation of dual database will make slow down the harmful intended person from sniffing out details , as dual database are used we are separating the encrypted file in a different database and Key in a different database which are encrypted using AES algorithm so that it is hard to find the respective file and key at the same moment .

### 3.2.1 System Architecture

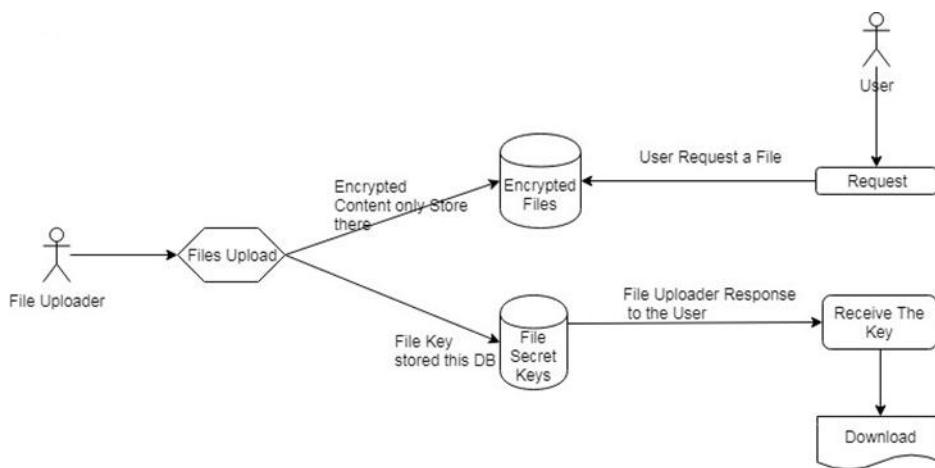

Fig 1 System Architecture of proposed work

#### A. Files upload

User registers and sign up for creating an account ,creating an account is mandatory in order to upload or download the documents, the documents are encrypted at the time of uploading and a secret key is generated.

#### B. Encrypting Files

The user uploaded files have been uploaded successfully and encrypted via AES algorithm for their respective key , here encrypted file is stored in a separate database and key in a separate database which have been kept together in existing schema led to provide both key and file at the same time, instead it have been kept at a different database so that its hard to find the respective encrypted file to its corresponding encrypted key making the obscure group of people who have the intention to steal it from data owner , this provides robustness more to the proposed scheme.

#### C. Privacy Protection

In our proposed scheme we are trying to implement the file accept or decline request from the data owner, the base paper existence proposed to use relay nodes which takes control of the owner's data as a real owner which

Result in deciding everything , so we try to remove the relay node from equation and we are giving out the authentication towards the respective data owners to share their data to corresponding users who needs the data.

### 3.2.2. Functional Modules

- User interface design
- Upload Files
- Admin Login
- Admin Encrypt Whatever uploaded
- File and Key Split and stored in AESerent tables
- User request
- Data Owner Response
- User Download

#### User interface design:

We are going to design out user interface in webpage, so we are using HTML5 and CSS for Interface design and JavaScript for client scripting languages.

#### Upload Files:

A data owner can upload data from his personal drive attached to computer so that it will be uploaded he can upload as many as files he want except a virus which should not be uploaded, if so there is a chance of spreading the virus all over the network.

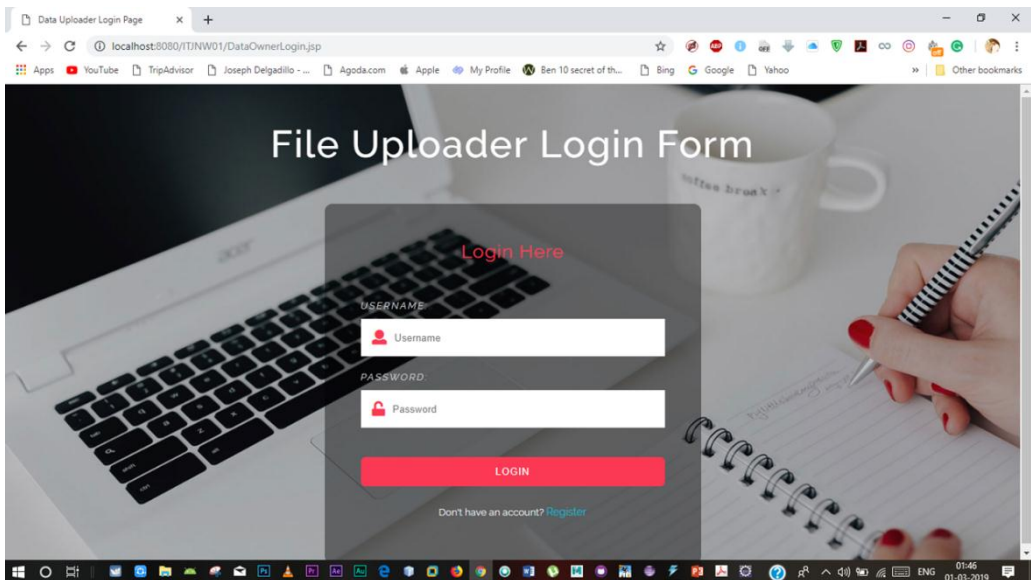

#### Admin Login

Admin can login to the network so that to view the files check for data de duplication, remove if the file is susceptible, inspect the account of user, encrypt the files, provide the key for encrypted file.

#### Encryption

The files uploaded are reviewed by admin and once its declared the files are safe to be stored, the files are now being encrypted using AES and a secret key is generated for every file, which is the main encryption of files happening over the process.

#### Files and key are stored in different database

The main concept of the proposed scheme is to store encrypted files at a separate place ie., a database and the key for respective encrypted file at a separate database so that for example if an hacker tries to get the data and its key previously, if he hacks a single database both keys and its respective files will be found, instead of this we are using multiple database which is secured more in a way so that if hacker hacks the file database he cannot get the key for the respected file and if key is found he cannot pinpoint the corresponding file.

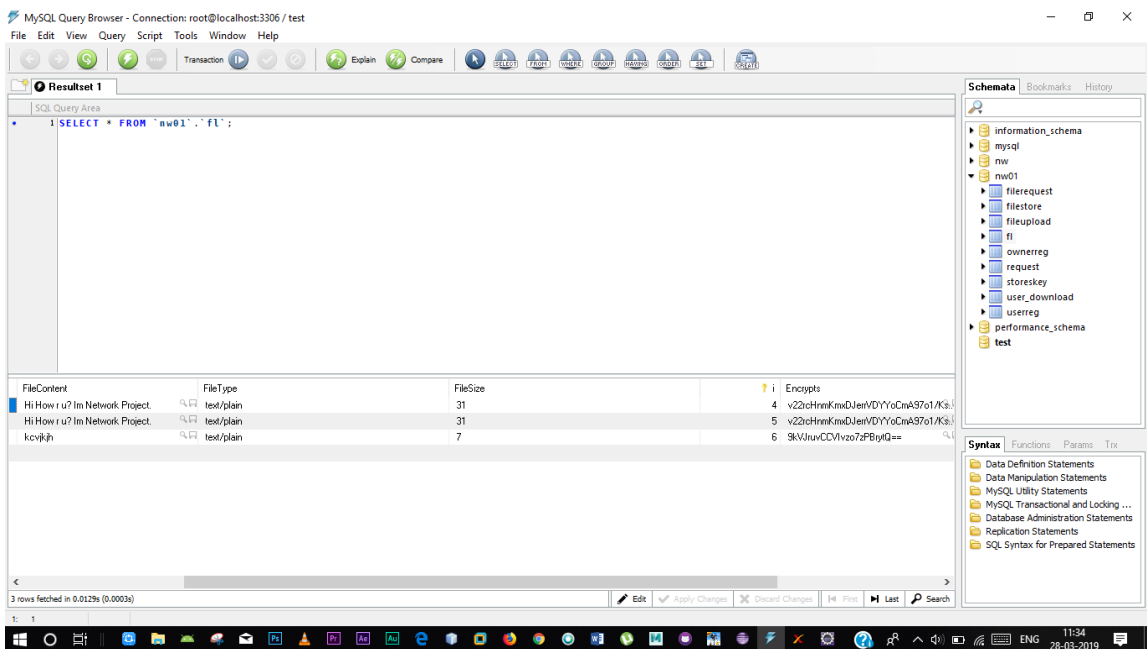
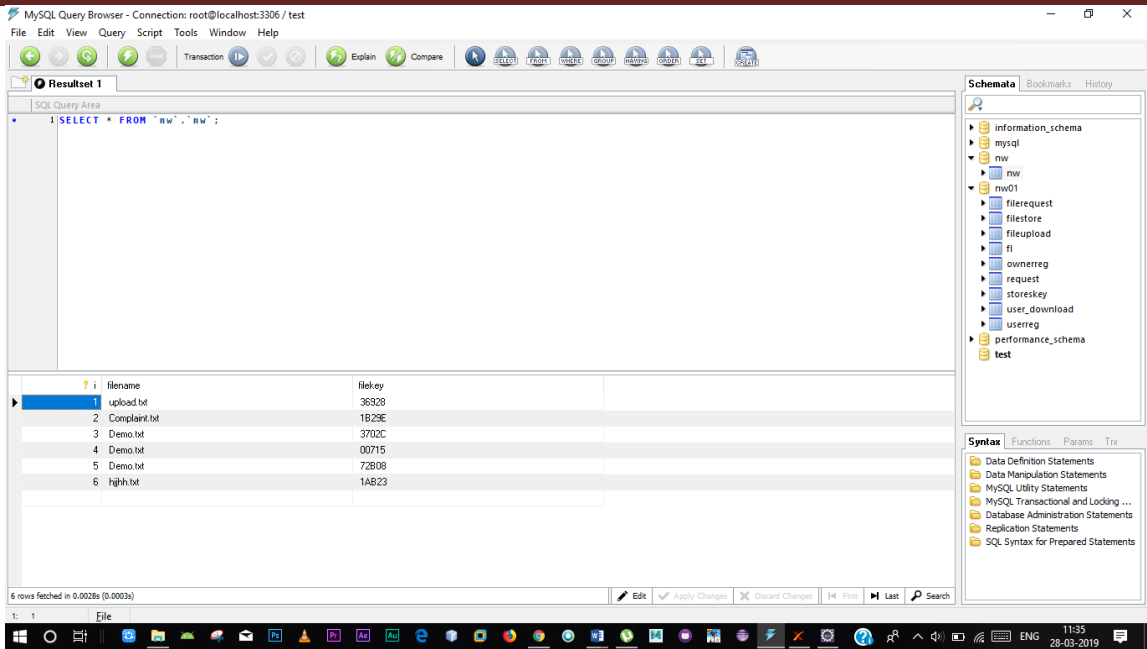

### User request

If user wants to see the data uploaded by owner he can request for the data to be downloaded only if he is an authenticated user and he can send the request to download the file.

### Data owner response

We are providing the privacy protection for data owner by asking out permission to data owner and discovering the truths about the user and his identity, if he wills to share the data he can accept the request or he can decline the request.

### User Download

After the data owner accept the request of the user to download the data file then he can download the intended file.

### **3.3 Comparison of existing system with proposed system**

In existing system the selection of node is quite irregular which lead to higher transmission cost , proposed system helps this by selecting frequently updated nodes so that transmission cost will be lesser. In existing system modifying the data included complete modified data along with original data to modify in storage node , proposed system solves this by including DIFF algorithm which only needs modified part to be sent instead of original and complete data again to storage node. The existing system uses relay nodes which takes ownership of the data so that we cannot trace back the leak if it caused by relay nodes so we are going to implement authentication from data owner to give permission in order to view or modify data .

### **4. Conclusion**

The process such as involved in P2P network in this paper make secure the p2p network the closest storage node update selection can reduce the transmission cost so that only frequently updated nodes will be used for storage selection. The Diff algorithm made possible to change the modified part instead of sending the complete modified file along with the original file as it was sent in conventional scheme now modifying the data is quite easily because of the Diff algorithm and for privacy protection we are not going to use relay nodes as it takes the ownership of the data and can be manipulated and this lack of integrity is now overcame by asking permission from data owner if the user wants to download the data so that we can have the log of which people have requested the file to download, and using out multiple database for storing the encrypted files at a different database and key at a different database confuse the harmful intended people to stop them from stealing out the data as if the person gets the encrypted file the key is not found in the same exact database and if key alone is found we cannot pinpoint the corresponding encrypted file, this makes the P2P more secured by this way.

### **References**

1. TessemaMengistu\*, AbdulrahmanAlahmadi\*, Abdullah Albuali, Yousef Alsenani, and DunrenChe, "A "No Data Center" Solution to Cloud Computing", 2017 IEEE 10th International Conference on Cloud Computing
2. Jong-Hoon Lee,Young Soo Kim,Young Soo Kim,IkKyun Kim "Toward the SIEM Architecture for Cloud-based Security Services",2017 IEEE Conference on Communications and Network Security (CNS): IEEE CNS 2017 – Posters
3. Ahmad Sanda Musa,HamadAlmohannadi,JassimAlhamar "Malware Propagation Modelling in Peer-to-Peer Networks: A Review", 2018 6th International Conference on Future Internet of Things and Cloud Workshops
4. Masayuki Fukumitsu\*, Shingo Hasegawa†, ShujiIsobe†, Jun-yaIwazaki‡, Eisuke Koizumi† and Masao Sakai†,"A Method for Constructing an Autonomous Decentralized P2P Storage with High Confidentiality and Reliability", 2017 Fifth International Symposium on Computing and Networking.
5. Ricardo Koller, Ali Jos'eMashtizadeh, RajuRangaswami" Centaur: Host-side SSD Caching for Storage Performance Control" 2015 IEEE 12th International Conference on Autonomic Computing
6. Nikos Fotiou, Giannis F. Marias, George C. Polyzos, "Access control enforcement delegation for information-centric networking architectures"ICN '12 Proceedings of the second edition of the ICN workshop on Information-centric networking
7. Florian Jacob ; Jens Mittag ; Hannes Hartenstein, "A Security Analysis of the Emerging P2P-Based Personal Cloud Platform MaidSafe"2015 IEEE Trustcom/BigDataSE/ISPA
8. Yahyahassanzadeh-Nazarabadi,AlpetikinKupcu and oznurozkaşp "Awake: Decentralized and availability aware replication for P2P cloud storage"

---

# Sentiment Analysis on 2019 Indian election using unsupervised learning on Twitter data

M Rangan, M Poonkodi, S Vijayakumar, S Aravind  
Department of Computer Science and Engineering,  
SRM Vadapalani,  
Chennai, India

---

**ABSTRACT:** Election campaigns are influenced greatly by social media. Platforms such as Twitter has allowed politicians to address a large group of audience. Here, we analyze a group of opinions taken from twitter to represent the public's view of the two major political parties competing in the Indian 2019 presidential election, namely BJP and Congress. The boundless reach of opinions over social media and the ability to express every individuals view in the form of short 'tweets' becomes a rich source of data which can be analyzed to predict the overall opinions accurately. The proposed method performs pre-processing to clean the data, which is to be processed further using K-mean clustering algorithm aided by generality transformation and predict the overall result. The system performs better than the existing methods of standalone classification or majority voting methods.

**Keywords:** Twitter; Twitter Sentiment analysis; public opinion mining; Election prediction; 2019 Election prediction;

---

## 1. Introduction

Opinion minion, also called as sentiment analysis is the method of analyzing the feelings and emotions of peoples towards a particular product or a service. Sentiment classification refers to the classification of a particular text based on its sentiment and polarity. Predicting the future scope of a product or a service can achieved using Sentiment Analysis. However, manually analyzing large data of opinions/ text can be tiring or nearly impossible task. Many types of sentiments related to different fields can be analyzed using opinions like Information regarding customers in places such as: Marketing, application marketing, online marketing websites etc. Sentiment analysis now plays an important role in understanding the opinion of the public. The ultimate goal of analyzing the sentiment of an opinion is to find the overall view about it or review about something.

The sequence of processes involves evaluation of the sentiment polarity and subjectivity. Social media platforms allows everyone from the president to the common man to discuss their views, read each other's views and discuss about the same. Furthermore, the increase in number of smart phones have enabled everyone to express their views about anything without a barrier. This medium of communication, presented by the social media, has been recognized by politicians and political parties globally. Citizens can have candid communication with government institutions through social media, thus allowing them to address each and every group of individuals and their problems.

Citizens from each state and local institutions have more confidence and greater transparency in sharing information and public engagement to civic services and police departments through Twitter. Statistically, during the first three months of 2019 Twitter has around 326 million active user per month which represents a great sum of the entire population of the voting people, thus allowing the political parties to reach and understand the needs and requirements of common people. With the growth of technology and its reach to every group of people across the globe, Social media covers a large set of people from almost all locations. Social media platforms specially Twitter which allows everyone to represent their views in short texts called 'tweets', not more than 140 characters of length is the most popular micro blogging service which represents a rich source of information and an effective communication tool with hundred millions of users. Twitter allows 140 characters short text messages called tweets which enables the users to create, send, read and talk about everything and anything. As twitter generates a large of amount of data, the researchers are attracted to this data.

## 2. Related work

Here, we discuss the works that are related closely to the work presented in this paper. The performance of various traditional classifiers with popular voting ensemble classifiers have not yielded better results than the proposed method, which had better performance comparatively with standalone classifiers and majority

voting classifier. Several techniques were based on standalone classifiers or majority voting methods, where the results were extracted by comparing weighted and unweighted voting schemes. Bag-of-words were used to find the sentiment. [1] Proposed an ensemble classifier which used majority vote for analysis of the sentiment, the results appeared to be that ensemble classifier performed well.

The sentiment of a word or a specific phrase differs from sentiment of the entire tweet. To perform the extraction of data and classification of sentiment automatically from the extracted tweets, [6] uses computational techniques combined with text analysis and NLP (Natural language processing).

SentiStrength algorithm played a major role in the US presidential elections 2016 [7], it was used to extract the views, positive, negative or neutral of values over 2.5 million tweets having tag of US presidential elections. Unexpectedly, neutral tweets were predominant one over the positive and negative values. The authors of [7] studied the twitter activity related to the 2016 US presidential election by using the method of geo-tagging. On the contrary to previously discussed papers which depends on SentiStrength, [7] proposes STS(Stanford's Twitter Sentiment) distant and corpus supervision which was used to train the classifier and validate it.

Some took an initiative to differentiate broadcasted tweets and a user interactive behavior by using the betweenness centrality measure to find the target users in the network. To classify a group of topics over twitter during Korean presidential election held in 2012, they used the LDA(Latent Dirichlet Allocation) to a group of tweets. They decided to rectify the spread of misinformation, which they found out to be that some of Van der Bellen's followers have been voluntarily involved in spreading misinformation. They also found out that the actual events may sometimes not correlate to the increasing activity over twitter, rather it was just the spread of misinformation about the presidential nominee. A regression analysis was performed which disclosed a patten, where in emotional tweets were mostly related to positive ones. They found that candidates used defaming campaigning strategies to get more followers or supporters. Authors found this by executing natural language processing (NLP) techniques. The difference between misinformation and negative views were also studied and noted that misinformation which led to negative opinions were more popular in the 2012 Korean election.

The works of [9] are closely related to the use of machine learning approaches to find the polarity of opinions, it focuses mainly on the use of supervised learning method. The authors also proposed a method to predict the polarity of tweets by grouping them into 'classes' and assigning a weight to each.

### **3. Proposed methodology**

The three main module of the System are as follows:

1. Data Pre-processing: Performs cleaning of data.
2. Tokenization: Extracts features from the tweets
3. Sentiment classification using K-Means: K-Means algorithm is used to classify the text to positive, negative or neutral.

#### **3.1. Data pre-processing**

Pre-processing is performed to clean the data, so as to prepare it for the next stage of processing, In this case, A tweet may contain any of the following which is removed or modified to further processing.

- Various tweets which are Re-tweeted contain RT at the beginning, this is eliminated for further processing.
- All usernames preceded by "@" and any reference to external links are removed.
- Trending topics which are represented by '#' are removed
- Short forms are converted to their respective acronyms.

#### **3.2. Tokenization**

Tokenization is the method of breaking up a sentence into pieces and tagging them into words, keywords, phrases, symbols and other elements called tokens. Each token is tagged with an attribute such as adjective, noun, and assigned a weight by using Bag of Words. This weight is used to find the sentiment of a sentence. Each evaluation of sentiment using Tokenization or NLP requires the BOW(Bag Of Words), the weightage assigned by the BOW to each word plays an important role in the overall value estimation.



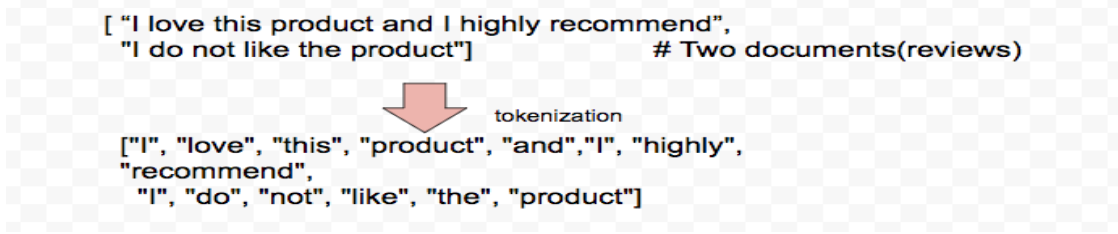

Fig 3.1 Tokenization sample

### 3.3. Sentiment Classification using K-Means

K-means is an unsupervised learning algorithm used to perform classification, it can be used specifically when there is unlabeled data (data which does not have a defined group or class). This algorithm aims to classify the data into groups where K represents the number of groups or clusters.

The working of this algorithm can be summarized into the following steps:

- First the K value is initialized by the user.
- K random points are assigned in the graph
- Using one of the distance calculation metrics (Euclidian Distance is used in this case) each item in the graph is assigned to one of the K points in the graph.
- This way, all points are assigned to one of the K points represented in the graph.
- The centroid or mean of all data points in each cluster is calculated, and the above two points are repeated.
- Finally the K number of clusters and their values are determined.
- This process is repeated with different values for K and the ideal one is determined.

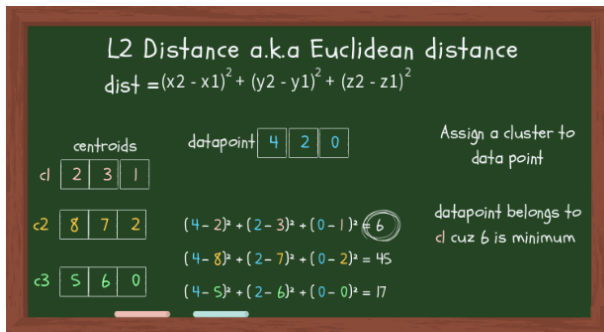

Fig 3.2 Euclidean Distance calculation

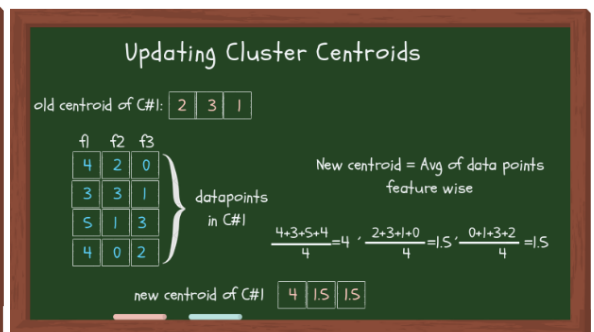

Fig 3.3 Cluster

#### Centroid Update

The points which were mentioned are called means, because they are the mean values of the data points which are categorized. To determine these mean points, there are a list of options. An instinctive method is to initialize the means to random value in the data set. Another way is to initialize the value to a random values between the boundaries of the data set. K-means is a simple algorithm that is adopted in various domains. K-means clustering has uses in various fields such as search engines, market segmentation, statistics etc. K-means clustering is specifically used for clustering analysis, mainly in the field of data mining and statistics. Its goal is to partition a set of observations into a number of clusters (k), which results in the partitioning of the data into cells. It can be considered as a method of finding out which group a certain object may belong to. It is used mainly in the field of statistics and also in other domains. For example, in the field of marketing, it can be used to group people of different demographics into simple groups that make it an easier target for the marketers.



$$J = \sum_{j=1}^k \sum_{i=1}^n \|x_i^{(j)} - c_j\|^2$$

number of clusters:  $k$   
 number of cases:  $n$   
 case  $i$ :  $x_i^{(j)}$   
 centroid for cluster  $j$ :  $c_j$   
 objective function:  $J$   
 Distance function:  $\|x_i^{(j)} - c_j\|^2$

Fig 3.4 K-means calculation function

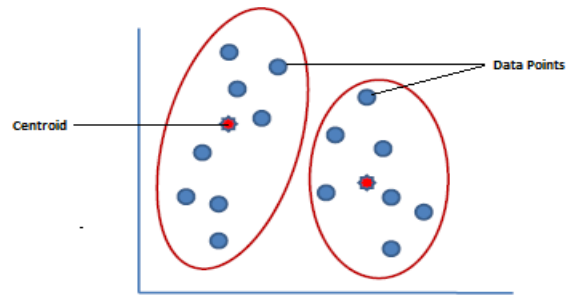

Fig 3.5 Cluster sample

The generality transformation algorithm is an improvement algorithm, used to transform the data into more accurate values based on the features and values extracted. By using this algorithm the accuracy can be further improved by around 10% - 20% in cases where majority of the data can further be refined to represent more accurate values of the sentiment. This effectively increases the quality of data which represents each sentiment and enhances the overall classification to provide more accurate results. On comparative study, this method proves to be greatly influential to the classifier, thus allowing the system to perform better than other standalone classifiers.

#### 4. Implementation details

The implementation of the entire project is done in python. All of the data has been collected real time from Twitter. Tweets related to “Modi” and “Congress” which represent the top two political parties competing in the upcoming 2019 elections were taken and organized into a csv file with relevant details. All this data has been pre-processed to clean the data for proper sentiment evaluation.

Data preprocessing involves removal of various twitter features and other operations such as stop word removal, abbreviations, spell check etc. were performed. With the help of “text-blob” and Bag of Words, the sentiment and polarity of each tweet is evaluated and stored. In the next steps, the entire data has been organized into clusters of three labels namely, Positive, Negative and Neutral based on their sentiment and polarity scores using K-means clustering algorithm.

Pandas was used to perform all data frame operations, NLTK was used to perform sentiment evaluation, Numpy was used to perform various matrix operations, Matplotlib was used to implement graph and chart diagrams, sklearn was used to import the kmeans algorithm.

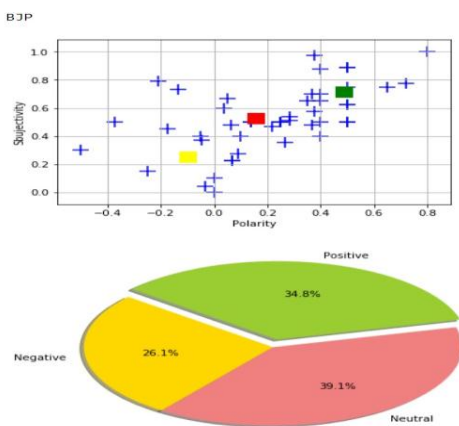

Fig. 4.1 Cluster of data for BJP

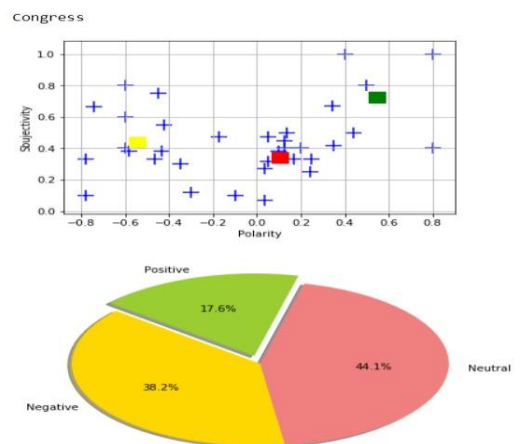

Fig 4.2 Cluster of data for Congress

#### 5. Evaluation

On comparison of the proposed classifier with other individual classifiers and majority voting classifiers, the proposed system performed better than standalone classifiers and majority voting classifiers. The proposed

system achieved an average f1 score of 0.94. These metrics prove that comparatively, the proposed method performs better than existing methods. On average, the system achieved a recall score of 0.935 and precision score of 0.945.

$$\text{recall} = \frac{\text{true positives}}{\text{true positives} + \text{false negatives}} \quad \text{precision} = \frac{\text{true positives}}{\text{true positives} + \text{false positives}}$$

$$F1 \text{ Score} = 2 * \frac{\text{precision} + \text{recall}}{\text{precision} + \text{recall}}$$

Fig 5.1 Evaluation formulae

The confusion matrix, used to evaluate the overall performance of the system on two sets of data is represented below

Confusion Matrix :

```
[[14  0  0]
 [ 0  8  0]
 [ 1  2 21]]
```

Accuracy Score : 0.934782608696

Report :

	precision	recall	f1-score	support
0	0.93	1.00	0.97	14
1	0.80	1.00	0.89	8
2	1.00	0.88	0.93	24
avg / total	0.94	0.93	0.94	46

Fig 5.2 Confusion matrix for BJP data

Confusion Matrix :

```
[[14  0  1]
 [ 1 12  0]
 [ 0  0  6]]
```

Accuracy Score : 0.941176470588

Report :

	precision	recall	f1-score	support
0	0.93	0.93	0.93	15
1	1.00	0.92	0.96	13
2	0.86	1.00	0.92	6
avg / total	0.95	0.94	0.94	34

Fig 5.3 Confusion matrix for Congress data

## 6. Conclusion

In the evolving field of data analysis on public platforms like twitter, the major issue arises in the selection of the best classification and evaluation algorithm. The proposed system proves to be effective in evaluation and classification of sentiments. Sentiment analysis proves to be very impactful in various decision making and opinion mining fields.

The proposed paper discusses the opinion of public over the two main parties involved in the Indian presidential election 2019. The output of the model provide results which show that more public opinion about BJP government is neutral or positive, and less negative, whereas, the opinions about the congress government is more negative and neutral than positive. All the data related to the opinions were collected real time from twitter.

The model provides an insight into the impact of Sentiment analysis and its boundless scope into various fields and domains. The US Presidential elections during 2012 proved the impact of proper utilization of opinion mining and analysis, the 44th president of the US used the big data analytics to collect the needs of each individual, vote by vote. This way, the classical method of advertising such as T.V etc. were beaten and allowed the reach of the party to every group of individuals. By doing so, the needs and requirements of every individuals were spoken.

## References

1. Ankita, Nabizath Saleenaa, An Ensemble Classification System for Twitter Sentiment Analysis. International Conference on Computational Intelligence and Data Science (ICCIDIS 2018).
2. Agarwal,A.,Xie,B.,Vovsha,I.,Rambow,O.,Passonneau,R.,2011. Sentiment analysis of twitter data Association for Computational Linguistics.

3. Shiyang Liaio, Junbo Wangb, Runiyun Yua, Koichi Satob, Zixue Chengb., 2016. CNN for situation understanding based on sentiment analysis of twitter data, 8th International Conference on Advances in Information Technology, IAIT2016, 19-22 December 2016, Macau, China.
4. Prabhsimran Singha, Ravinder Singh Sawhney, Karanjeet Singh Kahlona., 2017. Sentiment analysis of demonetization of 500 & 1000 rupee banknotes by Indian government, ICT Express 4 (2018) 124–129.
5. Ema Kušen , Mark Strembeck ., Politics, sentiments, and misinformation: An analysis of the Twitter discussion on the 2016 Austrian Presidential Elections, Online Social Networks and Media 5 (2018) 37–50. URL : [www.elsevier.com/locate/osnem](http://www.elsevier.com/locate/osnem)
6. Doaa Mohey El , Din Mohamed Hussein., A survey on sentiment analysis challenges. 2016. Faculty of Computers and Information, Cairo University, Cairo, Egypt.
7. Ussama Yaquba , Soon Ae Chunb , Vijayalakshmi Atluria , Jaideep Vaidyaa., Analysis of political discourse on twitter in the context of the 2016 US presidential elections.
8. Tajinder Singh, Madhu Kumari ., Role of Text Pre-Processing in Twitter Sentiment Analysis. Twelfth International Multi-Conference on Information Processing-2016 (IMCIP-2016).
9. Ibrahim N.F., Wang X. & Bourne H., Exploring the effect of user engagement in online brand communities: Evidence from Twitter, Computers in Human Behavior (2017).
10. Rexiline Raginia, P.M. Rubesh Anandb, Vidhyacharan Bhaskarc., Big data analytics for disaster response and recovery through sentiment analysis. Department of Electrical and Computer Engineering, San Francisco State University, 1600 Holloway Avenue, San Francisco, CA 94132, USA.

---

# A Productive DDoS TCP Surge Assault Identification and Aversion Framework in a Cloud

K.Karthikayani<sup>1</sup>, Milan patel<sup>2</sup>, Rudra Dev<sup>2</sup>, G .karthik<sup>2</sup>

<sup>1</sup>Assistant Professor, Department of Computer science and Engineering SRM institute of science and technology,Vadapalani,chennai-India

<sup>2</sup>Student, Department of Computer science and Engineering SRM institute of science and technology ,Vadapalani,Chennai-India

---

**ABSTRACT:** *In spite of the fact that the quantity of cloud ventures has significantly expanded in the course of the most recent couple of years, guaranteeing the accessibility and security of venture information, administrations and assets is as yet an urgent and testing research issue. Distributed denials of service assaults are the second most predominant cybercrime assaults after data robbery. DDoS TCP surge assaults can deplete the cloud's assets, expend a large portion of its data transfer capacity, and harm a whole cloud extend inside a brief timeframe. The convenient location and counteractive action of such assaults in cloud ventures are along these lines imperative, particularly for eHealth mists. In this paper, we display another classifier framework for distinguishing and forestalling DDoS TCP surge assaults (DDoS) in broad daylight mists. The proposed DDoS framework offers an answer for securing put away records by grouping the approaching parcels and settling on a choice in view of the order comes about. Amid the discovery stage, the DDOS recognizes and decides if a parcel is ordinary or begins from an aggressor. Amid the anticipation stage, bundles which are delegated vindictive will be denied access to the cloud benefit and the source IP will be boycotted.*

**Keywords:** *DDos Attack, Synchronize packet,Database access,authorized user*

---

## 1. Introduction

TCP SYN flood is defined as Distributed Denial of Service attack that make full use of conventional protocol triangular handshaking to ingest resources on the targeted server and make it unresponsive.

### Attack Description

when a consumer and server establish a standard protocol “three-way handshaking,” the exchange seems like consumer requests affiliation by causing SYN message to the server. Server acknowledges by causing synchronize-acknowledge message back towards shopper.

Shopper responds with ACK message, and therefore the affiliation is established.

SYN flood attack, offender sends perennial SYN packets to each port on the aimed server, usually employing a pretend IP address. The server, not knowing of the attack, receives multiple authorized requests to determine communication. It reply to every try with a SYN-ACK packet from every open port. Malicious packets doesn't send the ACK, or—if the IP address is hidden—never receives the SYN-ACK within the initial place but, the server under attack will response to the acknowledgement of its packet for a few time.

### There are some techniques to mitigate:

Miniaturized scale squares—chairmen can assign a small-scale record in the server memory for every approaching SYN demand rather than a total association object.

SYN treats—utilizing cryptographic hashing, the server send out its SYN-ACK reaction with an arrangement no. which is built from the customer IP address and perhaps other one of a kind recognizing data. At the point when the customer reacts, this hash is incorporated into the ACK parcel. The server checks the ACK, and at exactly that point allots memory for the association.

### Proposed system

We present new framework for recognizing and forestalling DDoS TCP flood assaults in cloud. The proposed DDoS framework offers an answer for verifying put away records by arranging the approaching packets and settling on a choice dependent on the arrangement results. Amid the discovery stage, the DDOS distinguishes and decides if packets is ordinary or starts from an attacker. Amid the counteractive action stage, packets which are named malignant will be denied access to the cloud administration and the IP will be boycotted.

Architecture diagram

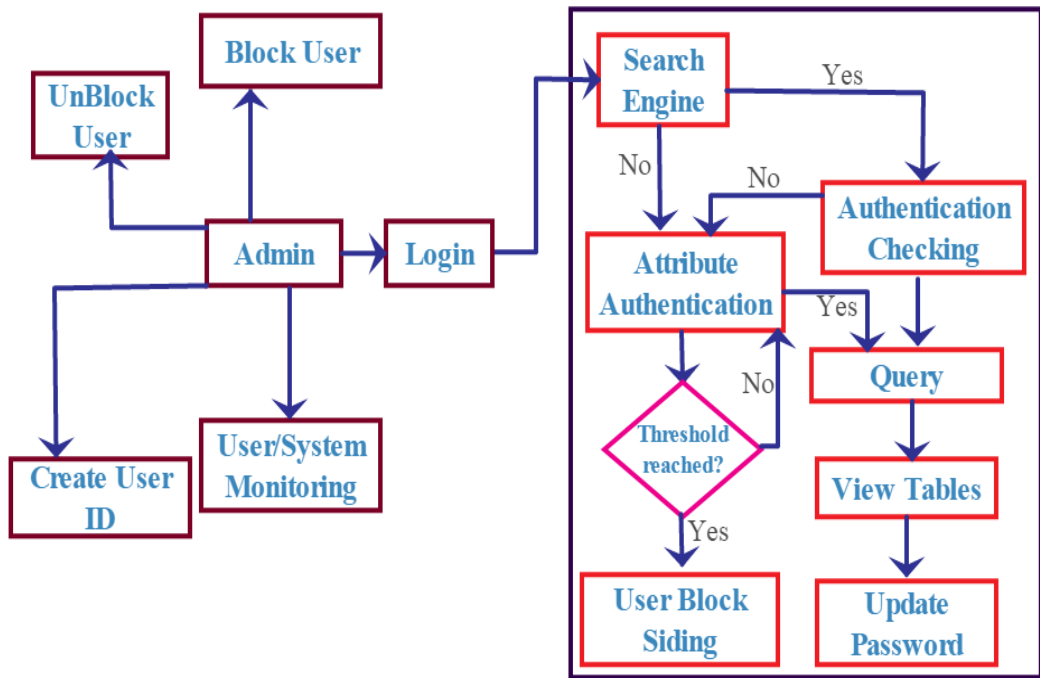

Architecture diagram

**Algorithm**

Genetic algorithm can be utilized to advance basic guidelines for system traffic. These principles are utilized to separate ordinary system associations from peculiar associations. These peculiar associations reference to occasions with chance of interruptions. The condition as a rule alludes to a match between current system association and the principles in IDS, for e.g. source and goal IP locations and port numbers, length of the association, convention utilized, and so forth., showing the likelihood of an interruption. The demonstration field more often than not alludes to an activity characterized by the security strategies inside an association, for e.g. revealing a caution to the framework overseer, ceasing the association, logging a message into framework review records, or the majority of the abovementioned.

**Modules**

- Intrusion Detection system
- Database details
- Anomalies detection
- Database access

**Intrusion Detection System**

It consists of 2 main parts, specifically to a DBMS: associate anomaly detection system. The primary part is predicated on the development of information access profiles of users, and on the employment of such profiles for the Adtask. A user-request that doesn't change to the conventional access profiles is characterised as abnormal. Profiles will record info of various levels of details. Subsequently we have a tendency to taking some actions once associate anomaly is detected.

**Database Details**

The user should be a authenticated user to use a database. The authentication is proved by giving the credentials by the user. Then user have to give the details of the database which he wants to access like database schema, attribute etc, then only user can access the database.

**Anomalies Detection**

IDS are wont to find anomalies with the aim of catching hackers before they are doing real harm or misuse the info. The malicious activities are detected through the incorrect credentials given by the unauthorized user or hacker. If any user continues to relinquish the info details incorrectly for three times. Then his account is blocked mechanically.

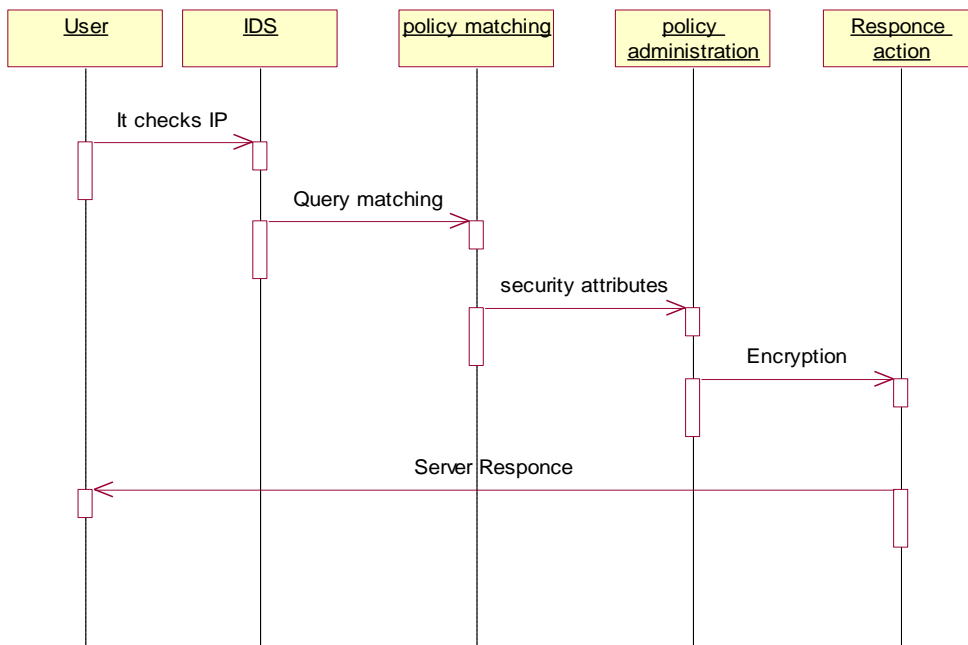

Sequence Diagram

**Database Access**

For accessing the database, the users have to give query as the format of SQL query. If the user is proved to be authorized user, The user can access any database. After giving the query, the user has to redirect to the respective database which they want to access. The user has to provide database password for accessing. If the user don't have password, then they will redirected to password generation process.

**Requirements Engineering**

**Hardware Requirements**

- System : Pentium IV 2.4 GHz.
- Hard Disk : 40 GB.
- Floppy Drive : 1.44 Mb.
- Monitor : 15 VGA Colour.
- Ram : 4 GB.

**Software Requirements**

- Operating System : Windows.
- Front-End Tool : JAVA(Jsp/Servlets)
- Back-End Tool : MYSQL-Server
- IDE : Netbeans tool
- Web Server : Apacha Tomcat 6.0

**Conculusion**

The utilization of distributed computing in numerous segments is getting to be boundless, as this improves the framework in numerous regards. Be that as it may, this cloud venture is helpless against particular kinds

of assaults, for example, DDoS TCP flood assaults. In this manner, we propose another framework for recognition and counteractive action against DDoS for the discovery and aversion of DDoS TCP assaults. The framework depends on characterization to guarantee the security and openness of put away information, particularly essential for information records in police division. In this methodology, the approaching bundles are characterized to decide the conduct of the source inside a time period, so as to find whether the sources are related with a certifiable customer or an assailant. The outcomes demonstrate that, if any unapproved client barge in our framework, it's IP is blocked.

### **Acknowledgement**

The authors acknowledge Prof K.Karthikayani from SRM Institute of science and technology for their great contributions in writing help, language facilities and coming up with the design and proving correct steerage in making this work

### **References**

1. I.F. Akyildiz, W. Su, Y. Sankarasubramaniam and E. Cayirci, "A survey on sensor networks," *IEEE Communications Magazine*, vol. 40, no. 8, pp. 102-114, Nov. 2002.
2. I. Onat and A. Miri, "An intrusion detection system for wireless sensor networks," in *Proc. IEEE International Conference on Wireless and Mobile Computing, Networking and Communications*, Aug. 2005, pp. 253-259.
3. I. Butun, S. D. Morgera, and R. Sankar, "A Survey of Intrusion Detection Systems in Wireless Sensor Networks," *IEEE Communications Surveys & Tutorials*, vol. 16, no. 1, May 2014, pp. 234-241.
4. Y. Yu, K. Li, W. Zhou and P. Li, "Trust mechanisms in wireless sensor networks: Attack analysis and countermeasures," *Journal of Network and Computer Applications*, vol. 35, no. 3, May 2012, pp. 867-880.
5. O. Khalid, S. Khan. S. Madani and M. Khan, "Comparative study of trust and reputation systems for wireless sensor networks," *Security and Communication Networks*, vol.6, no. 6. 2013, pp. 669-688.
6. D. He, C. Chen, S. Chan, J. Bu and A. Vasilakos, "A Distributed Trust Evaluation Model and Its Application Scenarios for Medical Sensor Networks," *IEEE Transactions on Information Technology in Biomedicine*, vol. 16, no. 6, Nov. 2012, pp. 1164-1175.
7. D. He, C. Chen, S. Chan, J. Bu and A. Vasilakos, "ReTrust: Attack-Resistant and Lightweight Trust Management for Medical Sensor Networks," *IEEE Transactions on Information Technology in Biomedicine*, vol. 16, no. 4, Jul. 2012, pp. 623-632.
8. A. Girma, K. Abayomi, and M. Garuba, "The Design, Data Flow Architecture, and Methodologies for a Newly Researched Comprehensive Hybrid Model for the Detection of DDoS Attacks on Cloud Computing Environment," in *Information Technology: New Generations*, ed.: Springer, 2016, pp. 377-387.
9. B. Cashell, W. D. Jackson, M. Jickling, and B. Webel, "The economic impact of cyber-attacks," Congressional Research Service Documents, CRS RL32331 (Washington DC), 2004.
10. Q. Yan, F. R. Yu, Q. Gong, and J. Li, "Software-defined networking (SDN) and distributed denial of service (DDoS) attacks in cloud computing environments: A survey, some research issues, and challenges," *IEEE Communications Surveys & Tutorials*, vol. 18, pp. 602-622, 2016.
11. B.Wang, Y. Zheng, W. Lou, and Y. T. Hou, "DDoS attack protection in the era of cloud computing and software-defined networking," *Computer Networks*, vol. 81, pp. 308-319, 2015.



---

# Connecting with Music

<sup>1</sup>Sathya Priya VK, <sup>2</sup>Harish Keerthivasan V, <sup>3</sup>Aashika R, <sup>4</sup>Ashok D

<sup>1,2,3</sup>Student, Computer Science and Engineering, SRM Institute of Science and Technology, Chennai, India

<sup>4</sup>Assistant Professor, Computer Science and Engineering, SRM Institute of Science and Technology, Chennai, India

---

**ABSTRACT:** We propose a deep learning model that uses Long Short Term Memory Recurrent Neural Networks, in combination with MIDI format, one-hot encoded, binned dataset with pre-processing techniques applied on the data to manipulate temporal scope and granularity factors in order to algorithmically generate music from a model learnt using hyper parameters optimized for the task of maximizing expressiveness, timings and dynamics i.e., composing and performing music artificially in a manner that captures all the essence of human performance without any mechanization.

**Keywords:** Long Short Term Memory, Neural Networks, Music, Recurrent Neural Network.

---

## 1. Introduction

Music has always been a big part of how humans express themselves and their emotions. It is one of the most unique aspects of the human expression and creativity. Generating music is a complex process that involves various fronts – Understanding the complex structure, styles and notations of music, finding the best form of representation, and finally, ensuring that it is aesthetically pleasing. There are multiple difficulties at every stage of this process but exploring the art of generating music unlocks few mysteries about the creative aspects of human brain. It has also given insights in to related problems with long term structural dependencies, importance of data representations, decoding periodic patterns with some level of uncertainty etc.,

Over the years, multiple attempts have been made to tackle the problem of artificially generating music. However, most of these systems are handcrafted models based on rules, grammar, or probabilistic methods. These models are limited in their ability to generalize, capture the sequential nature of musical structure and produce music that is indistinguishable from humans. In the field of creative computing, the rise of machine learning and neural networks, has made way for advancements in algorithmic music generation. While these models have certainly pushed the envelope further and the results are quite captivating, they are still farther away from sounding similar to that of humans. They lack the expressiveness and dynamics that are the characteristic of a performance by humans. Hence, it is astronomical challenge to compose, represent and perform a piece with expressiveness on the same level of that of humans.

In this paper, we propose a deep learning model that aims at artificially generating music that has the timing, dynamics and expressiveness which are characteristic of musical performances by humans. The main work of this paper is the novel combination of data representation and neural network architecture that enables the learning of dynamics and expressiveness from classical music performances to output a piece that incorporates these attributes.

## II. Background

### F. Related Work

Speech generation, an extensive field of interest in machine learning and artificial intelligence, has seen great advancements over the years. While, music generation also falls under the subset of audio generation as speech generation, it has proven to be much more challenging due to creative nature and complex structure. Despite the difficulties, there have been attempts at generating music algorithmically. Once such model is WaveNet – a deep learning model for generating raw audio [1]. Although, the musical pieces generated from this model are interesting, it is mainly aimed at synthesizing raw sounds and speech signals, not music.

Early models use rule based or grammar-based methods, Markov chains, evolutionary algorithms etc., [2] [3] [4]. Examples of such systems include the ground-breaking expert system CHORAL which uses 350 rules to carry out the process of harmonization and melody generation [5]. However, these models are constrained to probabilistic methods and hence produce music without any expressiveness, length or content variability. Current systems use machine learning and AI methods such as deep learning to generate music such as CONCERT (CONNECTIONIST Composer of ERudite Tunes) [6] which uses a Recurrent Neural Network to model

and generate music. Despite being a pioneer system, it is dated in its data representation format, i.e., it does not utilise the latest available modelling of musical notations such as chords, pitch etc.,

Furthermore, other deep learning models that utilise recurrent neural networks, while being suitable for sequential data due to their capability to loop over input, have their limitations due to their limited memory. They are also restricted in their capability to model polyphonic music (i.e., musical pieces having more than one note at a time) which is the type of music most instruments produce. Improvements on such deep learning models are proposed by Boulanger-Lewandowski et al [7] ., This model uses a Sampling approach using Restricted Boltzmann Networks (RNN-RBM). This compounded architecture has two parts

- A vertical dimension (In musical terms, a chord or item-level) modelled by RBM Sampling -- describes the probability of the notes to occur together.
- A horizontal dimension (In musical terms, a melody comprising a string of notes or a sequence of items) modelled by RNN -- probability of a specific note appearing after another is defined by this dimension.

There have also been instances where Convolutional Neural Networks have been used for algorithmic music generation

Another important factor that has a tremendous effect on algorithmic music generation is the data representation of music. Due to its complex structure, music continues to be an elusive sequence of data to model. Appropriate representation of the musical data plays a huge role in generating music that satisfies all the requirements of a system. Much work has been done in this area such as Chord2Vec, a system that proposed an alternative way to model chords as a sequence of constituent notes [8]. Some attempts have been made to represent music in a text based structured format similar to markup languages such as XML and HTML but these formats are verbose and create overhead when used in machine learning models, and are hence used as an intermediate or interchange format [9] .

### G. Our Approach

In this paper, we propose a deep learning model that uses Long Short Term Memory networks (LSTM) [10], which are a type of recurrent neural networks with extensive memory to compensate for the long term dependency problem of RNNs. LSTMs are explicitly designed to learn long term dependencies and hence have no problem remembering sequences that have a huge gap in between. This architecture given in Figure 1 combined with the Musical Instrument Digital Interface (MIDI) format of data representation of music is the novelty of this project.

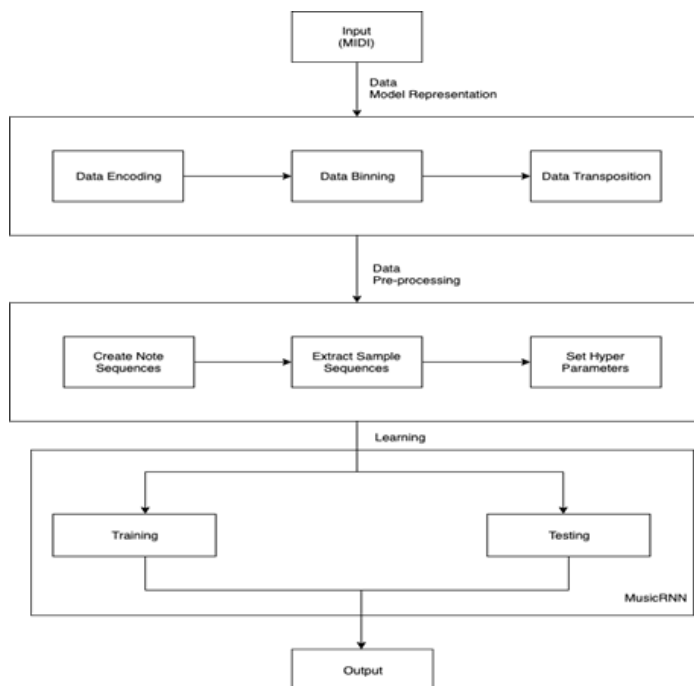

Figure 3: Architecture/Workflow Diagram

Other main contributions in the work of this paper include, the data set which is quantized in a manner to learn expressiveness of musical data. This enables us to generate music that is polyphonic in the style of classical piano, with dynamics, timing, velocity and other attributes that are characteristic of music generated by humans as a form of artistic expression.

### III. MusicRNN

#### H. Architecture

The main motivation behind this paper is the LSTMs, which are a special type of RNNs. The reasons are multifold – LSTMs are specifically designed with memory blocks to store previous state data, its inputs and the corresponding outputs, which are then used to provide a weighted output for the next state using a form of repeating modules of four different layers of neural network with a tanh structure which makes them ideal for processing sequential data like music, speech etc.,

Since they are also designed with extra memory blocks, they are extremely efficient at learning and remembering long term dependencies. This facilitates them to produce an output that is variable in content and length and not just restricted to playing the same melody or a same style repeatedly. This also enables them to sustain variability for a much longer duration. This is achieved by securing information in memory cells, so that they are hidden from the general data flow structure used by recurrent neural networks. The information in the cells can then be written to, read from, or forgotten (erased). Figure 2 illustrates the structure of a LSTM. These operations are performed by opening or closing of gates. LSTMs have three gates made up of sigmoid neural nets and a point multiplication operator. Each gate is modified by a weight parameter.

Each unit of LSTM maintains a memory,  $c_t$  at time  $t$ . The output is given by

$$c_t = \sigma_t \tanh(c_t) \quad (1)$$

where  $\sigma_t$  is an output gate that dictates the amount of memory content exposure.

The output gate is computed by

$$\sigma_t = \sigma(W_o x_t + U_o h_{t-1} + V_o c_t) \quad (2)$$

where  $V_o$  -- diagonal matrix. The updating of memory cell  $c_t$  is achieved through the addition of new content to the memory and partially forgetting the old memory content  $\tilde{c}_t$ :

$$c_t = f_t \circ c_{t-1} + i_t \circ \tilde{c}_t \quad (3)$$

where the new memory content is

$$\tilde{c}_t = \tanh(W_c x_t + U_c h_{t-1}) \quad (4)$$

The extent to which the existing memory is forgotten is modulated by a forget gate  $f_t$ , and the measure of how much of the new memory content is added to the memory cell is controlled by an input gate  $i_t$ . Gates are computed by

$$f_t = \sigma(W_f x_t + U_f h_{t-1} + V_f c_{t-1}) \quad (5)$$

$$i_t = W_i x_t + U_i h_{t-1} + V_i c_t \quad (6)$$

where  $V_f$  and  $V_i$  are diagonal matrices [11].

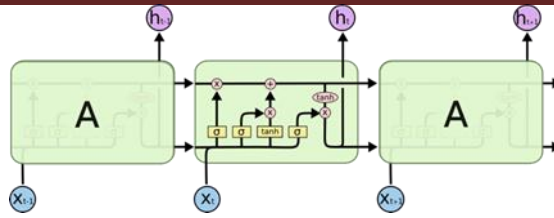

Figure 2: Structure of MusicRNN LSTM

I. Data Processing

As specified earlier, the data representation is tightly coupled to the input and output configurations. Even though the neural network architecture can learn and extract significant features from the data, the manner in which it is represented affects the quality and accuracy of the output generated. The factors to be considered before selecting the data representation are

- Type of music to be generated i.e., Polyphonic or Monophonic
- Destination of use of the generated output by the system i.e., End Users (Human/System)
- Mode of music generation involves the way music is generated i.e., with human interaction or autonomously.
- Use of the generated output i.e., A performance of the generated music or playing the audio file generated.
- Style of the music to be generated [12].
- The first step to picking the appropriate data representation is deciding on using a data format that is symbolic in nature (vs audio signals such as waveforms and spectrums.). Symbolic representation is much better at capturing the essence of the compositional process of music and is better suited for our application. It involved describing main concepts in music such as notes, chords, melodies etc.,
- The next stage involves picking a data format to represent the data in a way that is machine-readable. In this paper, we use MIDI which is a technical standard that describes a protocol for communication between electronic devices and instruments.
- A MIDI file is a collection of tracks and event messages. Events include real time performance data and other meta data about the tracks. The main events that are of significance in this project are :
  - ❖ **Note-on** events that include parameters to indicate the START of a note:
    - (1) A channel number – a set of integers between {0, 1,...,15} that indicate an active instrument or track.
    - (2) A note number – a set of integers between {0,1,...,127} that describes the note pitch
    - (3) A velocity –set of integers between {0,1,...,127} that describes the loudness of a note.

For example, “Note-on,0,60,50” indicates – “Start playing on channel 1, with 50 velocity, at middle C”. This is illustrated in Figure 3.

- ❖ **Note-off** events that include the same parameters indicating a note ENDING.
- ❖ **Tempo** – Number of beats per minute (BPM)
- ❖ **Instrument type**
- ❖ **Tick number** -- lowest level of time resolution. Describes the number of ticks passed between one event ending and the beginning of another.

```
2, 96, Note_on, 0, 60, 90
2, 192, Note_off, 0, 60, 0
2, 192, Note_on, 0, 62, 90
2, 288, Note_off, 0, 62, 0
2, 288, Note_on, 0, 64, 90
2, 384, Note_off, 0, 64, 0
```



Figure 4: Excerpt of a MIDI file and its corresponding musical score representation

- Next step in the process is Feature Extraction, which is done using accuracy, efficiency and precision factors in training as the motivating factor. Even though deep learning models are excellent at processing raw data and passing down patterns to subsequent layers to build a sophisticated model of data automatically, this is done to increase the gain and improve the model optimization efforts.
- Another important step after picking the data format is the process of encoding the data as inputs for the neural network. For this particular application, we use discrete variables to represent the data format attributes along with one-hot encoding i.e., as many input lines as there are pitches in the track collection.
- The data is then binned into 32 velocity bins i.e., all the velocity values are divided into discrete bins, which are then replaced with a value representative, usually the central value. This enables us to capture more information from the encoded data without losing the exact timings of note which is usually the problem faced when quantization is used. It enables us to capture exact information without any trade-offs, thus increasing expressiveness.

#### J. Dataset

A dataset plays a vital role in the outcome of a deep learning model. The size and coherence of the data are major factors in guaranteeing the desired output and quality in the generated output. The model was mainly learnt using the Yamaha e-piano competition dataset [13] which has ideal characteristics required for the scope of this paper. The characteristics are:

- It captures performances by many skilled human performers.
- Timings and velocity is calculated based on real time performance rather than an audio track. This ensures a higher level of expressiveness.
- All performances are composed and performed on a single instrument. This ensures coherence.
- Since, the performances are from a competition, the data set inherently obeys statistical constraints and hence is coherent in nature.

### IV. Experiments and Results

Once the architecture and the data models are finalized, experiments were designed to maximize the efforts of the model. This process is divided into four phases – Training, Testing, Generation and Visualization or Analysis of the results.

#### K. Training

This phase is divided into two steps – Pre Training and Training. Since this is the learning process and hence the most important, to ensure maximum efficiency of the system, a few additional steps were carried out before training the dataset on the LSTM.

These steps include:

- Transposition -- Augmenting the data set with synthetic performances to create a sizeable dataset for accurate generalization, and time stretching the performances by 5% to generate longer performances.
- Building the data set using protocol buffers [14], which is a language and platform independent mechanism for serializing structured data.
- Another important step in this paper is setting the temporal dependency and granularity, i.e., the way in which representation is interpreted by the architecture with respect to time. In this case, global temporal scope is used to process the input and produce output in one single step.
- The temporal granularity used in this paper is fixed time step, which allows us to capture the timings accurately from a human performance since the data is not quantized to a particular tempo.
- The next step involves creating sample sequences from the processed data. Two sets of sample sequences are created for testing and validation with a 90:10 split. Sample sequences enable the network to train without the overhead of going through the entire set of performances.
- Setting the hyperparameters for training and testing. Hyperparameters are attributes that are used to fine tune the learning process of the model to obtain optimal results.

#### L. Testing

In order to calculate the efficiency rates and ensure proper working of the architecture, testing and evaluation of neural networks are important. This phase involves testing the neural network on the 10% of

data split taken from the dataset for validation. In order to obtain the desired figures, the hyper parameters used are the same as that of the training phase. Feature Extraction step ensures that the hyper parameters chosen are optimal.

Table I Indicates the results metrics.

**Table I:** Results For 242 global steps/run

Measures	Values
Accuracy	0.8
Loss	0.0
Perplexity	1.0

**M. Generation**

This phase produces a MIDI like representation of music which can then be utilized for performance.

The representation comprises of 128 note-on ,note-off events, corresponding to 128 pitches, 100 time shift events at increments of 10ms upto 1 second, that control the rate at which the time shift events move forward. This is illustrated in Figure 4. This is an important factor in maximizing expressiveness. Finally, 32 velocity events, totaling to 388 events on which the network operates.

In order to control the generated output, several parameters can be modified. These include factors such as pitch values, melodies, number of notes per second, number of steps, number of outputs per run etc.,

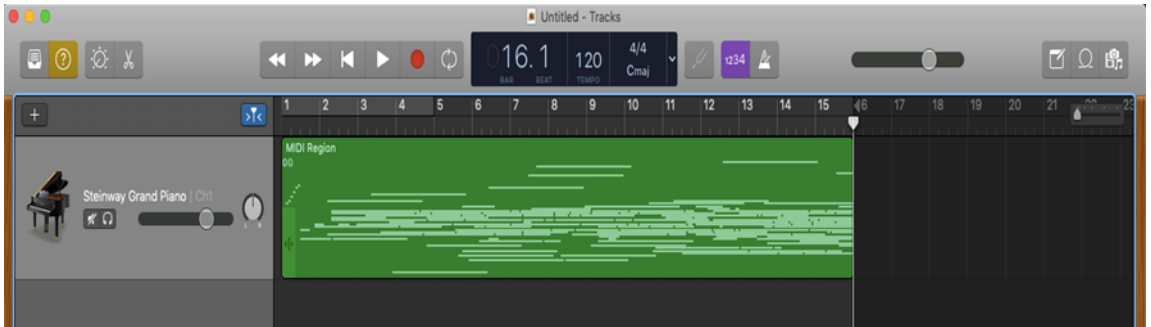

**Figure 5:** An Example Output Generated by MusicRNN

**V. Results and Visualization.**

This phase involves an analysis of the run and visualizing the results using Tensorboard functionality. Table II and Figure 5 are the sample screenshots from the initial training and evaluation run with 242 global steps using the given hyper parameter values on the Yamaha e-piano dataset which yield the above-mentioned result measures.

**Table 2:** Hyper Parameters

Parameters	Values	Meaning
Learning rate	0.001	The rate at which weights are adjusted with respect to loss gradient
Batch Size	1	Number of training examples propagated in one iteration.
Rnn Layer Size	512	Number of active fully connected weights
Number of Layers	3	Number of visible layers i.e., depth
Dropout Keep Probability	1	A way of regularization that determines the number of units set to zero decided at random
Gradient clip	3	Combats gradient explosion i.e., the value of a gradient grows to a extremely large value



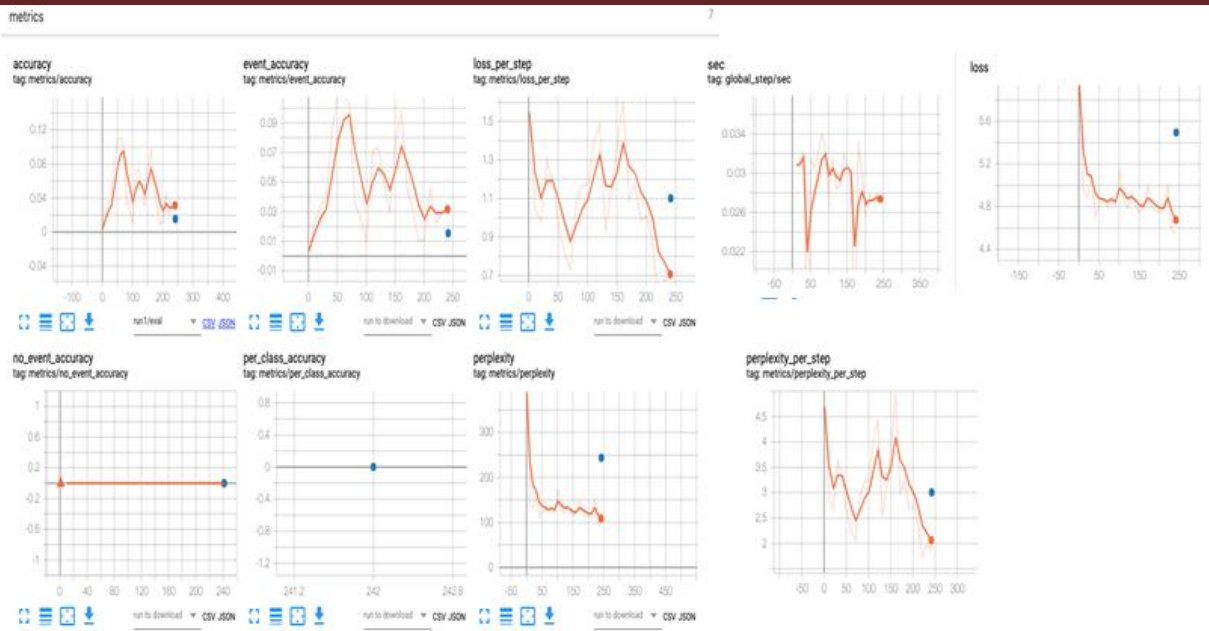

Figure 6: Screenshot of Result - Output Metrics of MusicRNN

### Acknowledgment

This paper was supported by SRM Institute of Science and Technology and its management. We extend our gratitude to them for providing us the opportunity to explore our interests. We extend our sincere thanks to Professor Mr D.Ashok for guiding us through every step of the way during the project. We are also grateful for the valuable insights and co-ordination provided by Mrs D.Punitha during the course of this work. We express our immense gratitude to the Dean , E&T, Dr. K. Duraivelu and HoD, Dept of Computer Science and Engineering , Dr. S. Prasanna Devi for being pillars of support.

### References

1. Aaron van den Oord, Sander Dieleman, Heiga Zen, Karen Simonyan , Oriol Vinyals , Alex Graves , Nal Kalchbrenner, Andrew Senior, Koray Kavukcuoglu, (2016) "WaveNet: A Generative Model for Raw Audio" , SSW
2. Quick, D. (2010). "Generating music using concepts from Schenkerian analysis and chord spaces". Tech. rep., Yale University.
3. Pestana, P. (2012). Lindenmayer systems and the harmony of fractals. *Chaotic Modeling and Simulation*, 1 (1), 91–99.
4. Ames, C., & Domino, M. (1992). Understanding music with AI, chap. Cybernetic composer: an overview, pp. 186–205. The MIT Press, Cambridge.
5. Baroni, M., & Jacoboni, C. (1978). Proposal for a grammar of melody : The Bach chorales. Les Presses de l'Université de Montréal.
6. Mozer, M. (1991). Music and Connectionism, chap. Connectionist music composition based on melodic, stylistic, and psychophysical constraints, pp. 195–211. The MIT Press, Cambridge.
7. Nicolas Boulanger-Lewandowski, Yoshua Bengio, and Pascal Vincent. Modeling temporal dependencies in high-dimensional sequences: Application to polyphonic music generation and transcription. In *Proceedings of the 29th International Conference on Machine Learning (ICML-12)*, pages 1159–1166, Edinburgh, Scotland, U.K., 2012.
8. Cheng-Zhi Anna Huang, David Duvenaud, and Krzysztof Z. Gajos. ChordRipple: Recommending chords to help novice composers go beyond the ordinary. In *Proceedings of the 21st International Conference on Intelligent User Interfaces (IUI 16)*, pages 241–250, Sonoma, CA, USA, March 2016. ACM.
9. Michael Good. MusicXML for notation and analysis. In Walter B. Hewlett and Eleanor Selfridge-Field, editors, *The Virtual Score: Representation, Retrieval, Restoration*, pages 113–124. MIT Press, 2001.



10. Sepp Hochreiter and Jürgen Schmidhuber. Long short-term memory. *Neural Computation*, 9(8):1735–1780, 1997.
11. Nikhil Kotecha, Paul Young (2018), “Generating Music Using an LSTM”, CoRRabs/1804.07300.
12. Jean-Pierre Briot, Gaetan Hadjeres and Francois Pachet (2017), “Deep Learning Techniques for Music – A Survey”, CoRR abs/1709.01620, 199 Pages.
13. <http://www.piano-e-competition.com/>
14. <https://developers.google.com/protocol-buffers/>

---

# Enhancement of Generative Adversarial Network for Image Generation

V Yaswanth Sai Kumar<sup>1</sup>, B Kesavaragavan<sup>2</sup>, GSRs Akhil<sup>3</sup>, M Akash<sup>4</sup>, D Punitha<sup>5</sup>

Department of CSE,  
SRM IST, SRM Vadapalani

---

**ABSTRACT:** Generative Adversarial Networks is a recent emerging research on AI using deep learning concepts. Generative adversarial networks comprises with two functions i.e. generator and discriminator. Generative adversarial networks having capability of generating images and have the power to estimate the distribution of real data samples and generated data from that distribution. GAN's [1] getting popular due to their variety of applications which contains image synthesis, super resolution, designing fields etc. In our work, we display how our model perform better compared to classic GAN model and few other GAN. In this paper, we discuss how to reduce training time and to increase the image resolution. Generator work is to generate the random samples and compares these generated samples with the original dataset in discriminator. Here we used inception score as cost function where it will correlate the generated image and real dataset. When the correlation is minimum then using back propagation, generator will again generate the sample by rectifying the error, which had occurred in the previous training. Convolutional neural networks (CNN) is used in discriminator for image classifying and random forest is used to optimize the training time.

**Keywords:** Generative Adversarial Networks, Convolutional Neural Networks (CNN), Random forest(RF).

---

## 1. Introduction

Generative adversarial networks is a popular technique for unsupervised and supervised learning. Ian Good Fellow proposed it in the year 2014[3].Generative adversarial networks has two functions. They are generator and discriminator. Generator acts as forger and discriminator acts as expert. Generator's main function is to create random samples that aims to generate like real images. Discriminator main function is to compare real dataset and the generated images that created by generator. Generator does not have the access to the real dataset. Discriminator has access to both the generated images and the real dataset. The cost function in the discriminator check whether the image generated came from the real dataset or not. If the generated image does not satisfy the cost function in the discriminator then it will again train the generator using back propagation until it satisfies the cost function. Our work aims at enhancing the image resolution and to decrease the training time. It can be achieved by making existing model in simple structure. In our model, existing discriminator work with random forest which boost ups classification time . This major change in discriminator leads to improvement on learning time.

## II Overview

Generative adversarial networks mainly focused on generating synthesis images based on existing dataset-trained knowledge. GAN's included with two major parts Generator (G) and Discriminator (D). The generator takes input of random noise (Z)  $I_{gen}=G(z)$ [2]. It transfers Z to image ( $I_{gen}$ ). Generated images in generator will be the input for the discriminator. Discriminator (D) takes an input from generator( $I_{gen}$ ) and discriminator is used to give probabilistic data. That the (D) is from original data distribution  $P_{data}$ . In training discriminator it will provide low probability value when generated ( $I_{gen}$ ) image is "FAKE". This will gradually trained to maintain low latency between generator and discriminator and this will be continued till Igen is classified as "REAL" by discriminator with comparison to  $P_{data}$ . With the innovation of new technologies and available resources many researchers have worked on Generative adversarial networks, and contributed many work hours to develop new techniques in this field. Here in this work we tried to enhance the image resolution using random forest. This project includes input of random images generated in generator and these generated images will be the input for the discriminator where it compares generated images with real dataset. We used convolutional neural networks to image classification in discriminator. The back propagation is used to train the generator again until it satisfies the cost function in discriminator.

## III, Existing System

### 3.1 Methodology:

This work has been carried out to enhance the image generation and to extract the required features of the image. It consists of two major steps.

- Generator
- Discriminator

**Block Diagram**

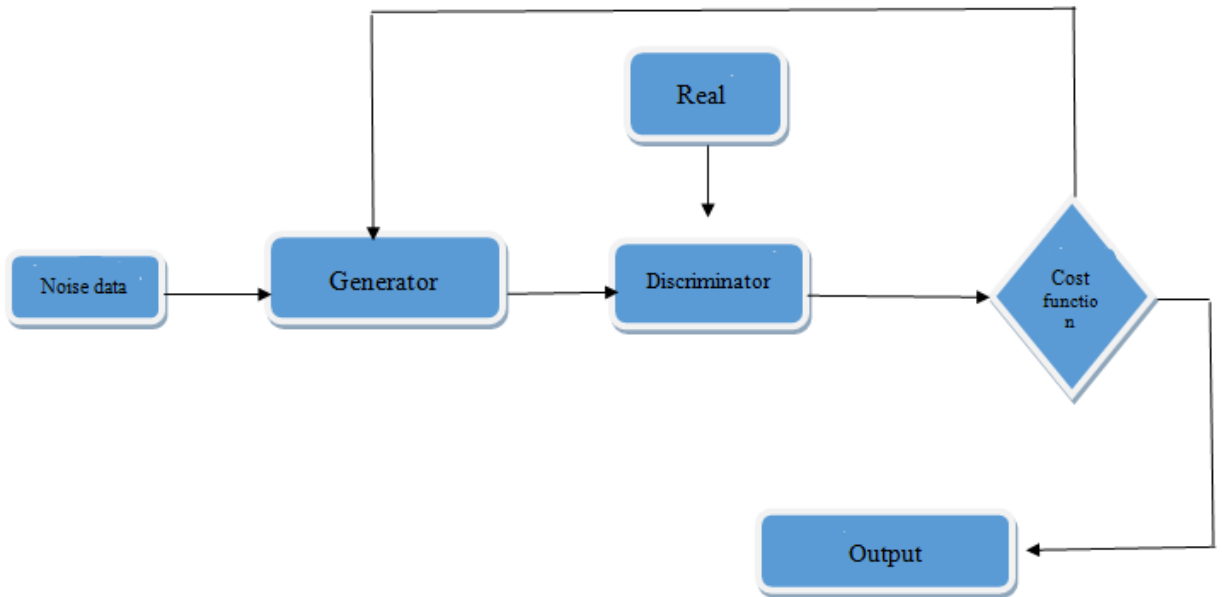

Figure 1: General Architecture diagram of GAN

**3.1.1 Generator**

In this module the generator is done with the given random noise data. The generator (G) takes input of random noise (z)[6]. It transfers Z to image (I<sub>gen</sub>). I<sub>gen</sub> = G(z). z uses random distribution. G learn to generate images from each learning dataset and back propagation is provided to measure generated image I<sub>gen</sub> accuracy and gradually work to reduce error.

$$\text{Min}_g V_g = \text{min}_g (E_{z \sim p(z)} [\log(1-d(g(z)))] )$$

**Image Database**

This work is primarily focused on various datasets like CIFAR 10, MNIST etc.

**MNIST Dataset:**

MNIST is the Modified National Institute of Standards and Technology dataset. This dataset consists of 60,000 images of 0 to 9 hand written data. We used the data for training which was optimized to 1000 images. This reduce of dataset is done images randomly with the constant number for every category. The training time is directly proportional to the size of data. This dataset can be accessed by the discriminator. In discriminator, the network has the number convolutional layers(CONV), batch normalization(bn) and parameterized rectification linear unit(PReLU).



Figure 2: MNIST data

### 3.1.2 Discriminator

Discriminator(D) takes an input from generator ( $I_{gen}$  and discriminator is used to give probabilistic data that the (D) is from original data distribution  $P_{data}$ . In training discriminator it will provide low probability value when generated ( $I_{gen}$ ) image is "FAKE". This will gradually trained to maintain low latency between generator and discriminator and this will be continued till  $I_{gen}$  is classified as "REAL" by discriminator with comparison to  $P_{data}$ . In this model for generated image we take  $P_D(G(z)) = 0.5$  above accuracy as acceptable image later this accuracy will be increased when model trained .

$$\text{Max}_d V_d(d,g) = \max_d (E_{z \sim p(z)}(\log(1-d(x))) + E_{z \sim p(z)}(\log(1-d(g(z))))$$



Figure 3: Existing Discriminator output

### 3.2 Random Forest:

Random Forest is a general classifier forming tree type structure used for both classification and regression. It contains collection of tree which will learn from the distributed dataset values. Independently at each level of node in a tree to determine splits in random forest and collection of tree formed together and data distributed among each tree separately. Final outcome is taken from the maximum number of votes from all tree is considered. Each tree present in random forest are built from the training sample N (total conditions in training set) cases from random distribution of original data. This results to the random forest where tree grow its maximum. According to number of decision at each nodes splits are made. For classification, the

number of votes from all the tree predictions are considered The higher number of votes will be elected as final prediction result.

**IV Proposed System**

In present GAN[2] training, we necessarily attempt to train a mapping from simple latent distribution which leads to deep generative networks. Discriminator are equally trained with fully connected layer results in dense connection and complex in structure. In turn to reduce the complexity of dense network, we exchange fully connected layer to decision forest, which is effective with less number of trees and we tries to reduce the depth of the tree present in random forest without producing any loss in training data. This lead to significant increase in training data.

In our proposed discriminator model, random forest is used for activation function and the model is straight forward on training and classifying  $I_{gen}$  with following structure(figure3). We can learn at parallel time instead of iteratively learning the values. This will reduce the stochastic hard routing approximation on the forward pass through the trees. The values from the last activation function from the (conv4) will be given to tree nodes in our random forest. This leads to maintain forward pass and backward pass simultaneously. This method allows to make update leaf and node in parallel.

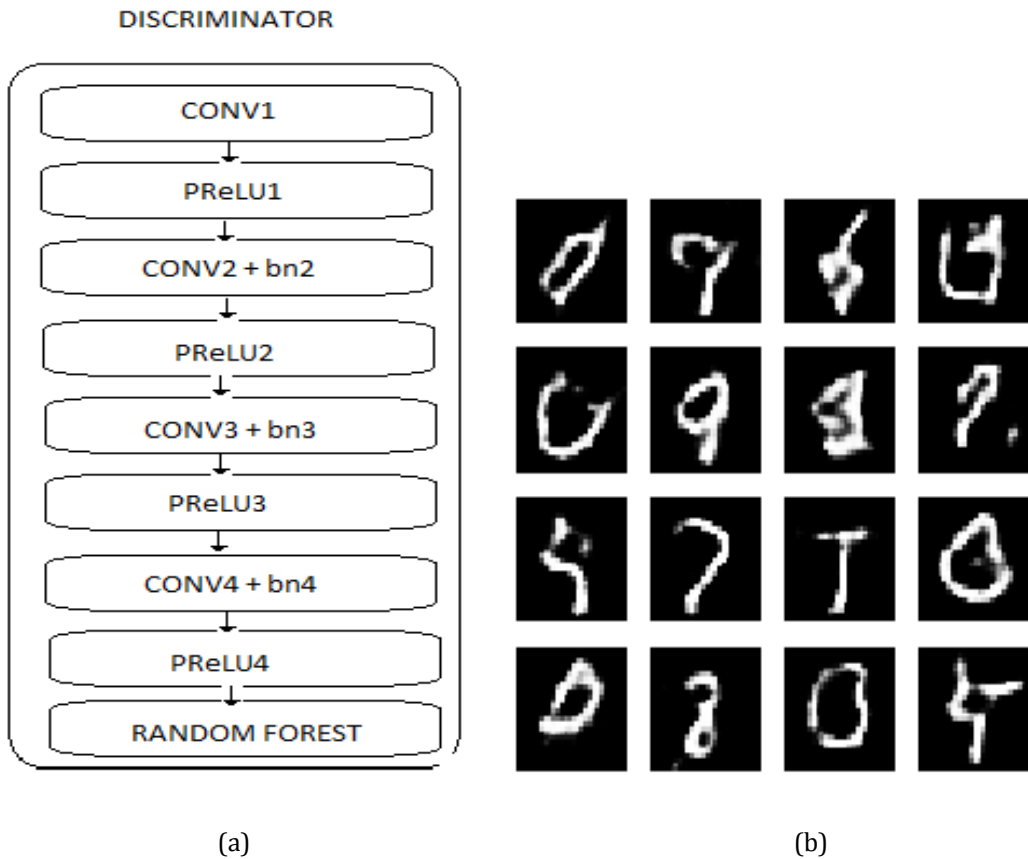
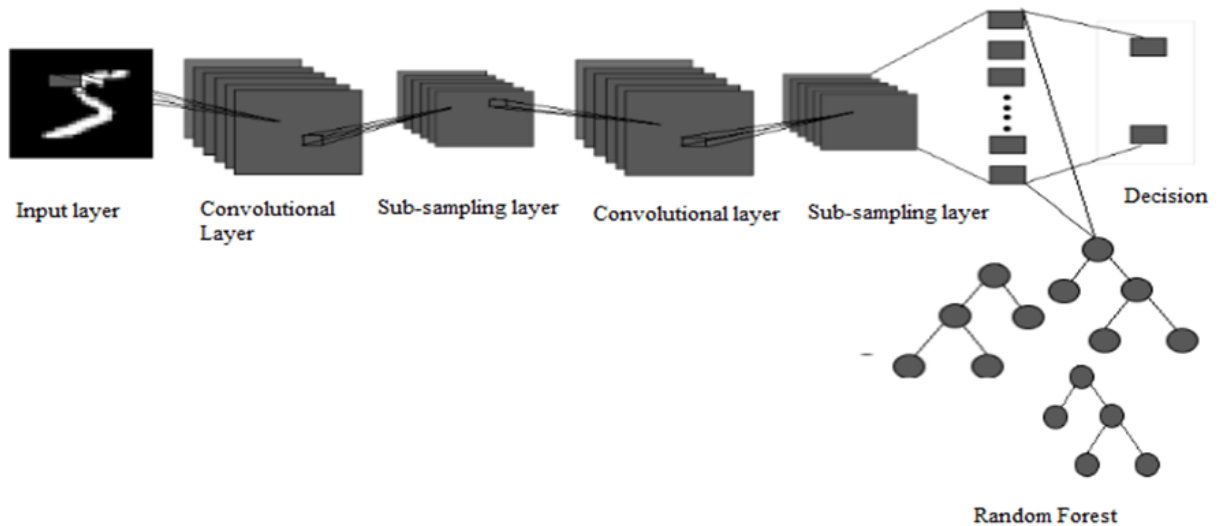

Figure 4 (a): Architecture of our proposed Discriminator model  
 Figure 4(b): Output generated from our proposed GAN Model



**Figure 5: Semantic representation of our discriminator model**

#### 4.1 Convolutional Neural Network – Random forest model:

The model shown in figure 5 is the CNN- RF model. The above given model approach consists of few process based on CNN and RF. Preprocessing, feature extraction are done based on convolutional neural network , post processing is done on constructed random forest model.

#### 4.2 Preprocessing Input Image:

Preprocessing is done to convert image to vector form without losing any information. In this part, images are pre-work with Gaussian filter and equalization, edges filter to extract information without any loss in features of an input image.

#### 4.3 Random Forest Post Processing:

This new method of approach loads to reduce in training vote. In common CNN fully connected layer used to classification which learn by each iteration i.e. if epoch is 200 and feature vector is 512 byte in size. It will consume more time for training. But our model overcomes effectively and it gets updated parallel. The extracted features from CNN are feed to random forest and instead of fully connected layer for learning. Each feature vector represent new pattern after training, it is ready for classification task and makes prediction on  $I_{gen}$  for generator by its extracted features. Now from random forest probabilistic value take as output for generated  $I_{gen}$  , then using loss function generator is updated.

### V Results

Results of the generative adversarial networks has been demonstrated in the figure 4. In training, attempt to train a mapping from simple latent distribution which leads to deep generative networks. Discriminator are equally trained with fully connected layer results in dense connection and complex in structure. In turn to reduce the complexity of dense network, we exchange fully connected layer to decision forest, which is effective with less number of trees and we tries to reduce the depth of the tree present in random forest without producing any loss in training data. The values from the last activation function from the (conv4) will be given to tree nodes in our random forest. This leads to maintain forward pass and backward pass simultaneously. This method allows to make update leaf and node in parallel. And provided model gives significant increase in training time and error are reduced compare to CNN discriminator. CNN with 200 epoch leads to effective result but training time will take couple of time. In our proposed model the effective training rate has increased and significant accuracy also achieved shown in table 1 .

Table 1.discriminator Classification Result of CNN vs Proposed Model(RF)

Network Model	Accuracy
CNN	0.8143
Proposed Model (RF)	0.8565

Table 2 .Inception Score for GAN vs ProposedModel on MNIST dataset

Network Model	Score
Real data	11.24
Proposed Model	<b>7.53</b>
GAN[1]	5.67

Inception score received according to respective model are shown in table 2. In that Proposed model in this paper has higher score of 7.53 .This results clearly proves that presented model is work effectively

## VI Conclusion and Future Work

In this paper we have presented a random forest in place of the fully connected layer in convolutional neural network in order to decrease the training time. This new method of approach allows to reduce loss in discriminator module . In common CNN fully connected layer used to classification which learn by each iteration. And time consuming process for learning . In future work it can be further implemented to increase the image resolution generated from our proposed model

## VII References

1. Antonia Creswell, Tom White, Vincent Dumoulin, Kai Arulkumaran, Biswa Sengupta, and Anil A. Bharath "Generative Adversarial network" IEEE Signal processing magazine conf., 2018
2. Swaminathan Gurusamy, Ravi Kiran Sarvadevabhatla, R. Venkatesh Babu, "DeLiGAN : Generative Adversarial Networks for Diverse and Limited Data" IEEE computer and vision processing conf., 2017
3. I. Goodfellow, J. Pouget-Abadie, M. Mirza, B. Xu, D. Warde-Farley, S. Ozair, A. Courville, and Y. Bengio, "Generative adversarial nets," in Proc. Advances Neural Information Processing Systems Conf., 2014, pp. 2672–2680.
4. J.-Y. Zhu, P. Krähenbühl, E. Shechtman, and A. A. Efros, "Generative visual manipulation on the natural image manifold," in Proc. European Conf. Computer Vision, 2016, pp. 597–613.
5. K. Bousmalis, N. Silberman, D. Dohan, D. Erhan, and D. Krishnan, "Unsupervised pixel-level domain adaptation with generative adversarial networks," in Proc. IEEE Conf. Computer Vision Pattern Recognition, 2016, pp. 3722–3731.
6. J.-Y. Zhu, T. Park, P. Isola, and A. A. Efros. (2017). Unpaired image-to-image translation using cycle-consistent adversarial networks, Proc. Int. Conf. Computer Vision. [Online]. Available: <https://arxiv.org/abs/1703.10593>
7. K. Arulkumaran, A. Creswell, and A. A. Bharath. Improving sampling from generative autoencoders with markov chains. arXiv preprint arXiv:1610.09296, 2016



---

# Build and Analysis of Question and Answering System

**B Subhashini, Kavipriya R, Harish P, BS Vidhyasagar,**

Department of CSE.

SRM Institute of Science &Technology,  
Bangalore, India

---

**ABSTRACT:** Question and answering (QA) system work on the Information Retrieval (IR) principle. They are different from a web-based search engine. With the help of internet-based search engines they provide answer by identifying the question and analysing the related information, but the system fails to provide precise answer. QA systems analyse references and related documents internally and provide precise answers to the queries thereby covering the limitations of search engines. We use techniques of Natural Language Understanding (NLU) for understanding the question and a simple Natural Language Generation (NLG) to predict the exact information. A QA system contains the main modules: classification of questions, data retrieval and extraction of answers. We use Euclidean distance and Cosine similarity to predict and match relevant answers related to questions raised by a user using Information retrieval.

**Keywords:** Question answering, answering system, Euclidean distance, Cosine similarity

---

## 1. Introduction

Question answering (QA) systems are powerful platforms in which it is used for automatically answering questions given by the user in natural language using either a pre-trained database or the documents of natural language. The possible ways of answering to the questions are done with the help of this system by retrieving the solutions for the given natural language.

An Interactive question-answering (QA) system deals with a query when asked in natural language with a question and brings outcome as Information Retrieval (IR) asked in natural language. A QA system makes different methods in asking questions and retrieves the information using Natural Language Queries (NLQ). The retrieved information for the given query is obtained from data collection in order to bring the exact answer [1-2].

IR is an open source used in QA system which extracts the answer as a response to the user query. The demand for this type of system is rapidly increasing nowadays. The system becomes user friendly when the natural language is being used as the input. But there are many types of questions because of which the system will find it difficult to implement and also to find the exact answer to return the precise data to the user. Also, with the help of Euclidean distance and cosine similarity we can retrieve short and precise answer. We try to implement the significant squad dataset to retrieve the data [2].

Stanford Question Answering Dataset (SQuAD) is the comprehension of dataset, which contains questions and answer where the data consist of text in the form of question and answer format, it searches the answers for the given query in the passage and brings the output to every question. As a result, with the help of these domains we identified how to approach to the problems [1].

## 2. Related Work

Here we are presenting a brief overview on related works done previously on QA system. The linear support vector machines (SVM) with all question n-grams were featured by Zhang and Lee. In this paper, they design and implement an intelligent question answering system using Natural Language Processing, template classification, and support vector machine. This system also calculates the similarity between the questions and answer pairs by cosine similarity algorithm, and returns the most similar answer. If the user is not satisfied with the answer, the system will write the question into the public section to fall back on other users. The answer will be evaluated and added to the QA base if it is passed with the corresponding question. So that the questions and answers in the QA base continue to expand [2]. Huang et al. in 2008 used combination support vector machines (SVM) and maximum entropy (MaxEnt) with question head words and their hypernyms as features to get 89.2% of accuracy on fine classes of UCIC dataset [3]. Question bigrams and error correcting codes are implemented by Hacioglu and Ward using linear SVM [6]. Hyo-jung-oh et al. used pattern extraction and the Descriptive Indexing Unix using pattern matching techniques. Using this technique, they achieved F score of about 52% on top1 and 68% on top5 [8]. Li and Roth developed in machine learning for question answering system in the year 2002 which is the first machine learning

system. The author used SNoW learning architecture for better outcome of the system[9].Using various types of words in the question processing, information parsing and semantic information Singhal et al. 1999 and Hermjakob 2001worked on QA system. This paper describes machine learning based parsing and question classification for question answering [11]. Lally Et Al classified questions in 12 different categories; the coarse classes are abbreviation, entity, description, human, location and numeric (question taxonomies). These classes are used using Jeopardy! Domain which focuses on descriptive type questions [15].

### 3. System Architecture

The QA system contains processing of Query, processing of data, processing of answer retrieval. The Question processing module comprises of Question analysis, classification and reformulation. The query defines the keywords to be used for the IR system to search the documents. The query processing module analyzes the question and process them by representing the information in the form of given natural language query. The module uses the WWW in retrieving the information and process using paragraph filtering and paragraph ordering. The user gives the query as input and retrieves the output in the form of relevant information. The main task of Document processing module is to determine the related answers and categorize accordingly. The outcome for the given query raised by the user is been validated followed by the three sub tasks of QA system are in this module these processes are done: answer identification, extraction and validation [4].

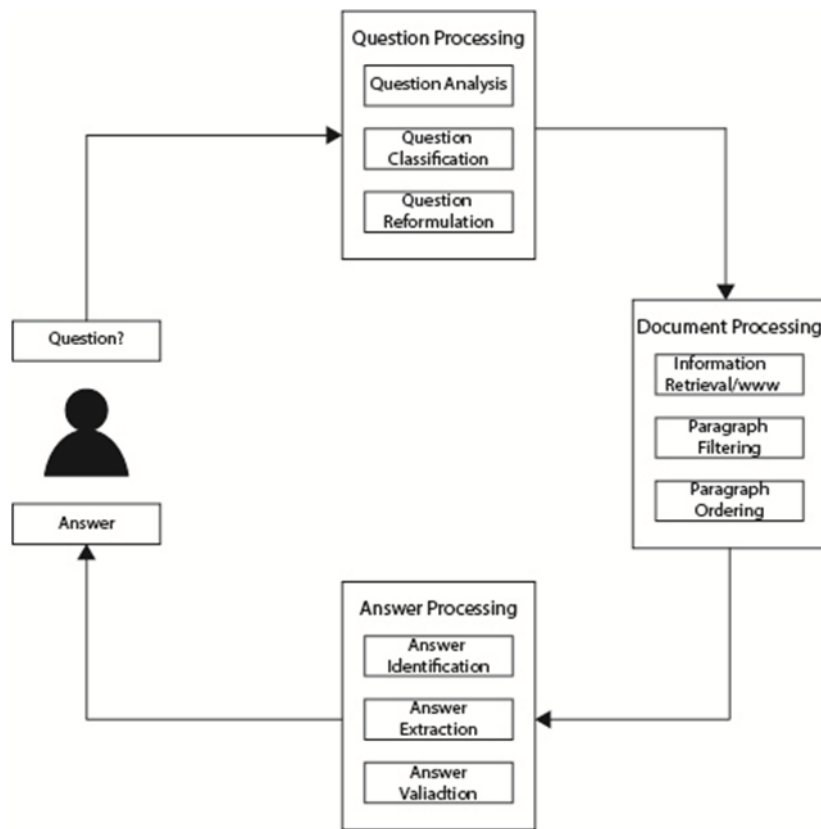

Figure 1: QA system architecture

The web search engine takes the user’s query in natural language. The question raised by the user is used in processing the solution by bringing the outcome of information retrieval. We use three modules in analysing the answer to the given query. The Question processing module contains three sub tasks; they are question analysis, classification and reformulation. The Document module uses the WWW in retrieving the information and process using paragraph filtering and ordering. The answer processing module consists of answer identification, extraction and validation. The precise solution to the query can be obtained from the

architecture model. The QA system delivers the answer with the certain amount of accuracy for the given query [2].

The system process begins with the user's question, and first uses the word segmentation tool to deal with the questions, including the removing of the stop words and user-defined word extraction. Then it judges the type of the question according to the rule-based question classification method, and then classifies the question to different courses. Then, it calculates the cosine similarity between the user questions, and takes out the highest similarity question answer feedback to the user [2].

### I. Methodology

The pre-trained neural network is used as an algorithm in finding the precision and accuracy level for the solution using information retrieval. We use SQUAD dataset in the form of JSON format (question and answer format). The NLU (Natural Language Understanding) for understanding the question and simple NLG (Natural Language Generation) for finding the answer prediction are the techniques used. The open source models such as rasa, deeppavlov are used as an open domain in answering to the given question. The software used is Python 3.7 using Spyder ide on anaconda.

### II. Challenges

In order to address these issues, we have developed a tool to quantify confusion between classes in a multi-class classification problem, which is in turn used for accurate ground truth. Taxonomy of label noise and a survey on how research has evolved in dealing with issues with label training samples is detailed. Since our system deals with user-generated textual data (conversational system), we find that grammatical incorrectness, spelling errors and disambiguation are abundant.

### III. Algorithm Used

We are using Euclidean distance and cosine similarity as an algorithm in which it is more efficient compared to other algorithms. This algorithm works on high computational process image &NLP and GPU. The other algorithms like SVM, Logistic Regression, K-means clustering works on CPU and brings the output and uses statistical models for bringing the outcome.

### 4. Result of the System

The result obtained from this research is to bring the exact answer for the question raised by the user with more efficiency by ordering and validating according to accuracy of the answer for the question.

	A	B	C	D	E	F	G
1	context	question	answer_start	text			
2	Architecturally, the school has a	To whom did the Virgin Mary allegedly appear in	515	Saint Bernadette Soubirous			
3	Architecturally, the school has a	What is in front of the Notre Dame Main Buildin	188	a copper statue of Christ			
4	Architecturally, the school has a	The Basilica of the Sacred heart at Notre Dame is	279	the Main Building			
5	Architecturally, the school has a	What is the Grotto at Notre Dame?	381	a Marian place of prayer and reflection			
6	Architecturally, the school has a	What sits on top of the Main Building at Notre D	92	a golden statue of the Virgin Mary			
7	As at most other universities, N	When did the Scholastic Magazine of Notre darr	248	September 1876			
8	As at most other universities, N	How often is Notre Dame's the Juggler publishe	441	twice			
9	As at most other universities, N	What is the daily student paper at Notre Dame c	598	The Observer			
10	As at most other universities, N	How many student news papers are found at Ni	126	three			
11	As at most other universities, N	In what year did the student paper Common Se	908	1987			
12	The university is the major seat	Where is the headquarters of the Congregation	119	Rome			
13	The university is the major seat	What is the primary seminary of the Congregati	145	Moreau Seminary			
14	The university is the major seat	What is the oldest structure at Notre Dame?	234	Old College			
15	The university is the major seat	What individuals live at Fatima House at Notre C	356	Retired priests and brothers			
16	The university is the major seat	Which prize did Frederick Buechner create?	675	Buechner Prize for Preaching			
17	The College of Engineering was	How many BS level degrees are offered in the C	487	eight			

Figure 2: Trained datasets

```

1 import warnings
2 warnings.filterwarnings('ignore')
3 import pickle
4 import numpy as np
5 import pandas as pd
6 #data = pd.read_json('/path/to/file.json', Lines=True)
7 import json
8 from textblob import TextBlob
9 import nltk
10 #nltk.download('punkt')
11 from scipy import spatial
12 import torch
13 from models import InferSent
14 #v1
15 MODEL_PATH = 'InferSent/encoder/infersent1.pkl'
16 params_model = {'bsize': 64, 'word_emb_dim': 300, 'enc_lstm_dim': 2048,
17                 'pool_type': 'max', 'dpout_model': 0.0, 'version': V}
18 infer_sent = InferSent(params_model)
19 infer_sent.load_state_dict(torch.load(MODEL_PATH))
20 W2V_PATH = 'InferSent/dataset/Glove/glove.840B.300d.txt'
21 infer_sent.set_w2v_path(W2V_PATH)
22 #infer_sent.build_vocab(sentences, tokenize=True)
23 infer_sent.build_vocab_k_words(K=100)
24 #f = open(EMBEDDING_FILE, encoding="utf-8")
25 #import spacy
26 #en_nlp = spacy.load('en')
27
28 train = pd.read_json('data/train-v1.1.json')
29 valid = pd.read_json('data/dev-v1.1.json')
30 #train.head(3)
31 # valid.iloc[1,0]['paragraphs'][0]
32 contexts = []
33 questions = []
34 answers_text = []
35 answers_start = []
36
37 for i in range(train.shape[0]):

```

Figure 3 a: Sentence embedding code

```

Python 3.6.8 [Anaconda, Inc.] (default, Dec 30 2018, 18:50:55) [MSC v.1915 64 bit
(AMD64)]
Type "copyright", "credits" or "license()" for more information.
IPython 7.2.0 -- An enhanced Interactive Python.

In [1]: runfile('C:/Users/Harish/Desktop/qa project/qa blog code/SQuAD/create_emb.py',
wdir='C:/Users/Harish/Desktop/qa project/qa blog code/SQuAD')
Vocab size : 100
1
2
3
4
5
6
7
8
9
10
11
12
13
14
15
16
17
18
19
20
21
22
23
24
25
26

```

Figure 3 b: Sentence embedding output

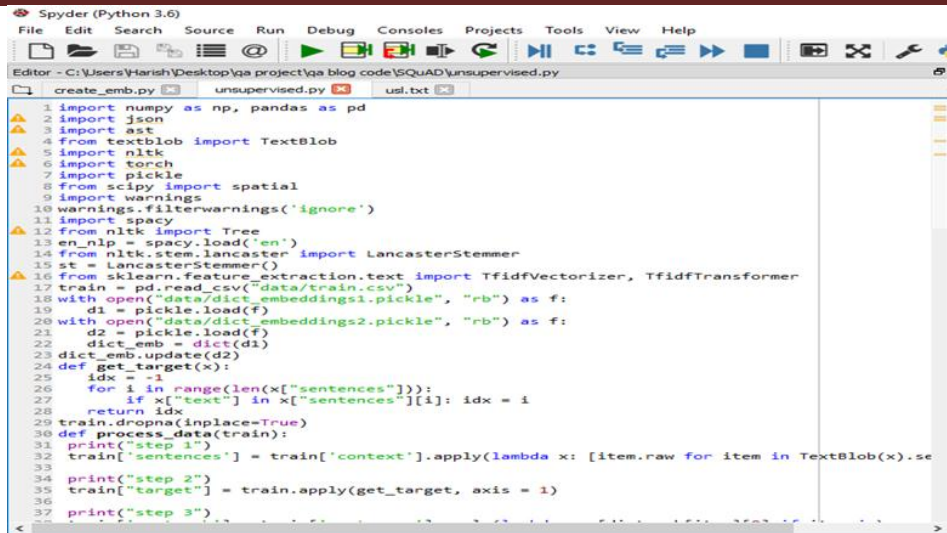

```
1 import numpy as np, pandas as pd
2 import json
3 import ast
4 from textblob import TextBlob
5 import nltk
6 import torch
7 import pickle
8 from scipy import spatial
9 import warnings
10 warnings.filterwarnings('ignore')
11 import spacy
12 from nltk import Tree
13 en_nlp = spacy.load('en')
14 from nltk.stem.lancaster import LancasterStemmer
15 st = LancasterStemmer()
16 from sklearn.feature_extraction.text import TfidfVectorizer, TfidfTransformer
17 train = pd.read_csv("data/train.csv")
18 with open("data/dict_embeddings1.pickle", "rb") as f:
19     d1 = pickle.load(f)
20 with open("data/dict_embeddings2.pickle", "rb") as f:
21     d2 = pickle.load(f)
22     dict_emb = dict(d1)
23     dict_emb.update(d2)
24 def get_target(x):
25     idx = -1
26     for i in range(len(x["sentences"])):
27         if x["text"] in x["sentences"][i]: idx = i
28     return idx
29 train.dropna(inplace=True)
30 def process_data(train):
31     print("step 1")
32     train['sentences'] = train['context'].apply(lambda x: [item.raw for item in TextBlob(x).se
33     print("step 2")
34     train["target"] = train.apply(get_target, axis = 1)
35     print("step 3")
```

Figure 4 a: Unsupervised code

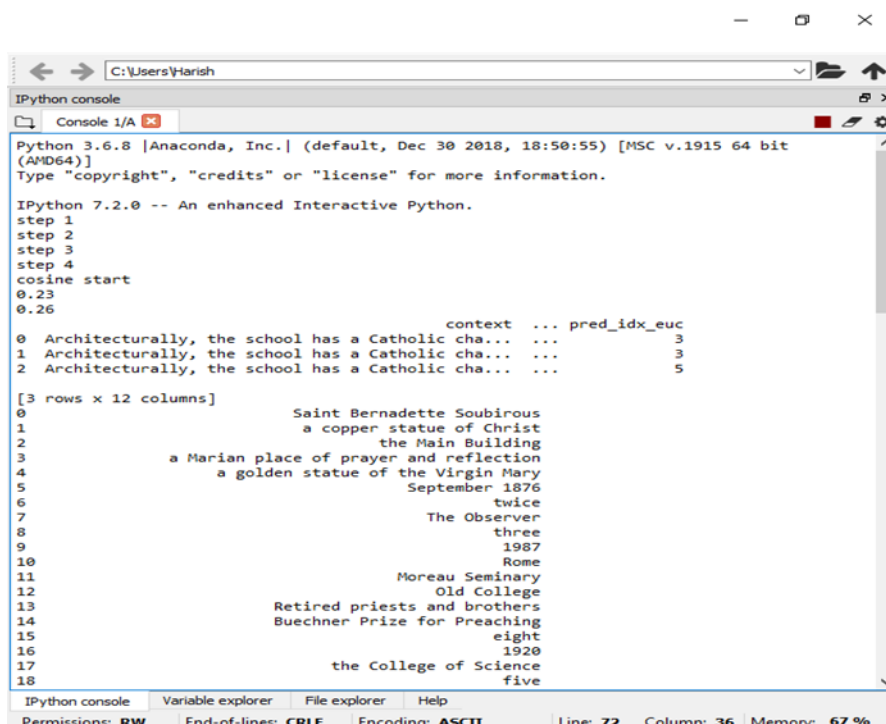

```
Python 3.6.8 [Anaconda, Inc.] (default, Dec 30 2018, 18:50:55) [MSC v.1915 64 bit (AMD64)]
Type "copyright", "credits" or "license()" for more information.

IPython 7.2.0 -- An enhanced Interactive Python.
step 1
step 2
step 3
step 4
cosine start
0.23
0.26
context ... pred_idx_euc
0 Architecturally, the school has a Catholic cha... ... 3
1 Architecturally, the school has a Catholic cha... ... 3
2 Architecturally, the school has a Catholic cha... ... 5

[3 rows x 12 columns]
0 Saint Bernadette Soubirous
1 a copper statue of Christ
2 the Main Building
3 a Marian place of prayer and reflection
4 a golden statue of the Virgin Mary
5 September 1876
6 twice
7 The Observer
8 three
9 1987
10 Rome
11 Moreau Seminary
12 Old College
13 Retired priests and brothers
14 Buechner Prize for Preaching
15 eight
16 1920
17 the College of Science
18 five
```

Figure 4 b: Unsupervised output



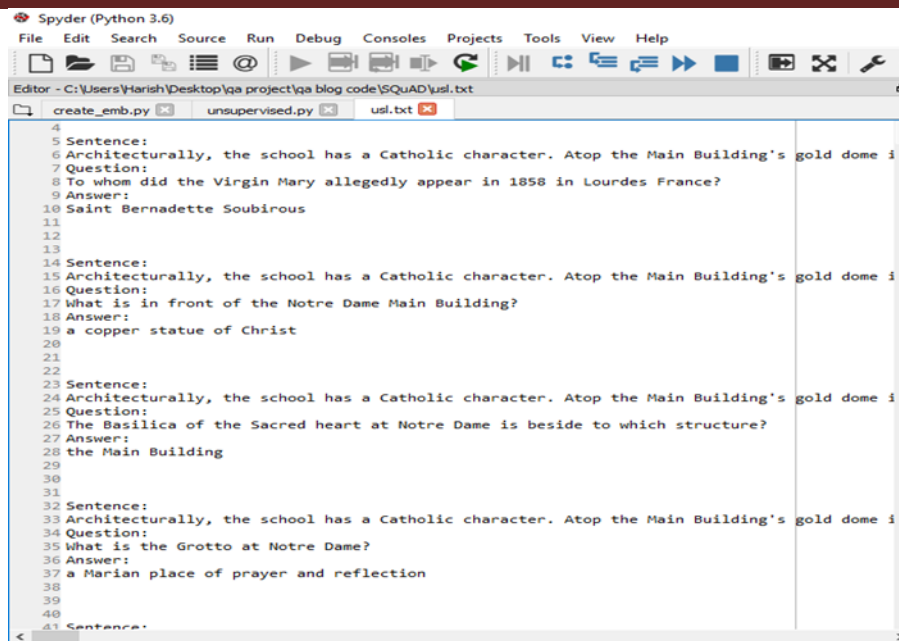

Figure 5: Output in text file

Table 1: Algorithm analysis with same dataset size

Algorithm used	Dataset size	Execution time
Euclidean distance & Cosine similarity	2 GB	1.25 sec
Logistic regression, Random forest & XG boost	3 GB	3.21 sec

### 5. Conclusion

The QA system has increased the delivering of most relevant answer to the user. In this paper the QA system focuses on these basic components: classification of questions, data retrieval and extraction of answers. Since, there is large number of data and information the chances of getting short and precise answers for the user is very less. This problem is overcome with the help of improving performance the QA system [5].

### 6. References

- Soares, Marco Antonio Calijorne, and Fernando Silva Parreiras. "A Literature Review on Question Answering Techniques, Paradigms and Systems." Journal of King Saud University-Computer and Information Sciences (2018).
- SONG, Wan-li, Wei-wei CHEN, and Ming-zhu ZHANG. "Intelligent Question and Answering System Based on SVM and Cosine Similarity." DEStech Transactions on Computer Science and Engineering mmsta (2017).
- Mishra, Shlok Kumar, Pranav Kumar, and Sujana Kumar Saha. "A support vector machine based system for technical question classification." In International Conference on Mining Intelligence and Knowledge Exploration, pp. 640-649. Springer, Cham (2015)
- Mathur, Ashish, and M. T. U. Haider. "Question answering system: A survey." In Proceedings of the International Conference on Smart Technologies and Management for Computing, Communication, Controls, Energy and Materials, May, pp. 6-8. 2015.
- Conneau, Alexis, Douwe Kiela, Holger Schwenk, Loic Barrault, and Antoine Bordes. "Supervised learning of universal sentence representations from natural language inference data." arXiv preprint arXiv:1705.02364 (2017).
- Hacioglu, Kadri, and Wayne Ward. "Target word detection and semantic role chunking using support vector machines." In Proceedings of the 2003 Conference of the North American Chapter of the Association for Computational Linguistics on Human Language Technology: companion volume of the

- Proceedings of HLT-NAACL 2003--short papers-Volume 2, pp. 25-27. Association for Computational Linguistics, 2003.
7. Li, Xin, and Dan Roth. "Learning question classifiers: the role of semantic information." *Natural Language Engineering* 12, (2006)
  8. Oh, Hyo-Jung, Ki-Youn Sung, Myung-Gil Jang, and Sung Hyon Myaeng. "Compositional question answering: A divide and conquer approach." *Information Processing & Management* 47, no. 6 (2011): 808-824.
  9. Li, Xin, and Dan Roth. "Learning question classifiers." In *Proceedings of the 19th international conference on Computational linguistics-Volume 1*, pp. 1-7. Association for Computational Linguistics, 2002.
  10. Singhal, Seema, Jayesh Mehta, Raman Desikan, Dan Ayers, Paula Roberson, Paul Eddlemon, Nikhil Munshi et al. "Antitumor activity of thalidomide in refractory multiple myeloma." *New England Journal of Medicine* 341, no. 21 (1999): 1565-1571.
  11. Hermjakob, Ulf. "Parsing and question classification for question answering." In *Proceedings of the ACL 2001 workshop on open-domain question answering*. 2001.
  12. Minaee, Shervin, and Zhu Liu. "Automatic question-answering using a deep similarity neural network." In *2017 IEEE Global Conference on Signal and Information Processing (GlobalSIP)*, pp. 923-927. IEEE, 2017.
  13. Bakis, Raimo, Daniel P. Connors, Parijat Dube, Pavan Kapanipathi, Abhishek Kumar, Dmitry Malioutov, and Chitra Venkatramani. "Performance of natural language classifiers in a question-answering system." *IBM Journal of Research and Development* 61, no. 4/5 (2017): 14-1.
  14. Chen, Ping, Timothy Simmons, Carlos Lacayo, and Wei Ding. "Parsing Tree Matching Based Question Answering." In *TAC*. 2008.
  15. Lally, Phillippa, Cornelia HM Van Jaarsveld, Henry WW Potts, and Jane Wardle. "How are habits formed: Modelling habit formation in the real world." *European journal of social psychology* 40, no. 6 (2010): 998-1009.



# Using Machine Learning for Web Application Development

<sup>1</sup>Sreekari D, <sup>2</sup>Ashwath, <sup>3</sup>Vinit

<sup>1</sup>Student, Department of Computer Science and Engineering, SRM Institute of Science and Technology, Chennai, India

<sup>2</sup>Intern,, Department of Computer Science and Engineering, SRM Institute of Science and Technology, Chennai, India

<sup>3</sup>Assistant Professor, Department of Computer Science and Engineering, SRM Institute of Science and Technology, Chennai, India

---

**ABSTRACT:** *The fundamental target of this paper is to concentrate on building up a web application which can be utilized by any client (mostly programming designers) to get an ideal code from a code repository. The point is to help the designers in lessening their time and exertion while coding. The client types the required code in basic English. With the assistance of Machine Learning, this information is separated into tokens which are then contrasted with the labels/tags in the current archive and the relating code piece is sent back to the user.*

**Keywords:** *Keyword extraction, machine translation, neural network, api.*

---

## 1. Introduction

In the course of recent years, the idea of Artificial Intelligence and its sub-subject Machine Learning have been actualized in different ways and aiming at different clients to make their work less demanding and diminish the work time. One such endeavor has been created here, focusing on, for the most part, the software developers who are required to compose numerous lines of code. Rather than investing energy and exertion on composing lines and lines of code, the developer/client can just enter a query for the code wanted and utilize the code snippet or the whole program provided by the repository. This model opts the concept of supervised machine learning. Based on the feedback provided by the user on the output returned, this machine learning application will improve its performance by training itself automatically.

### 1.1 Theoretical background

Artificial Intelligence has been part of our life for a decade now. We strongly believe that it will revolutionize our future. Analysts like Gartner, who has predicted all the major technological advancements says so too especially in the field of development. According to this article they predict that by 2022 almost 40% of projects will be powered by AI. Automating mundane and repetitive tasks will improve efficiency and quality of the product. Automation of these time-consuming tasks will support and encourage new ways of working in mobile, DevOps and Internet of Things (IOT) environments.

### 1.2 Motivation

During development of any software, a major time is spent by the software developer to find, analyze and debug code that they write/find. This time can be utilized in a more productive way if we can streamline the process of coding.

### 1.3 Existing System

#### 1.3.1 AskBayou

There currently exists a web service <http://www.askbayou.com/> which provides a similar service. However, askbayou provides the user only with three use cases such as, read file, write file, and remove list. Along with this limitation, askbayou provides code only in one language i.e., Java. This limits the usage of the user.[1][2]

#### 1.3.2 Spring Initializr

There exists another such service Spring Initializr which can be used to create or generate a project given two project options : Maven and Gradle. The user has a provision to choose between three languages (Java, Kotlin and Groovy). Depending on these and a few other specifications, the service generates a code.[3] The only concern is that this service doesn't actually generate a project code. Instead it just provides a basic project structure.

## 1.4 Proposed System

### 1.4.1 Aim of Proposed work

The long-term aim of this project is to develop a tool which will aid the developer to minimize their workload and improve the efficiency of the project. The developer enters the requirement and our engine tokenizes it and fetches either a code snippet or a JAVA project (.jar file) depending on the user requirement.

### 1.4.2 Objective of Proposed work

The objective of the proposed work is as follows:

1. Creating an algorithm which can identify sentences intelligently and extract the relevant keywords
2. Bundle the code together as a web application and host it on an EC2 instance
3. Expose this application as a service.
4. Use any REST service like POSTMAN API to call and use the service.
5. Use the data collected to improve the existing model
6. Finalize the web app and dockerize it for distribution.

## II. Amazon Web Services

In the implementation, we basically make use of AWS. Amazon Web Services (AWS) is a subsidiary of Amazon that gives on-demand distributed computing stages to people, organizations, etc., on the basis of paid membership system. The innovation enables endusers to have available to them a virtual bunch of PCs, accessible constantly, through the Internet. AWS's rendition of virtual PCs imitate the vast majority of the qualities of a genuine PC including equipment (CPU(s) and GPU(s) for handling, hard-plate/SSD stockpiling, neighborhood/RAM memory); a decision of working frameworks; organizing; and pre-stacked application programming, like web servers, CRM, databases etc. Each AWS framework additionally virtualizes its comfort I/O (console, show, and mouse), permitting AWS endusers of associate with their AWS framework utilizing a cutting-edge program. The program goes about as a window into the virtual PC, allowing endusers to sign in, mastermind and use their virtual systems likewise as they would a genuine physical PC. They can send their AWS structures/frameworks to give web-based organizations to themselves and their customers. The AWS innovation is executed at server cultivates all through the world and kept up by the Amazon auxiliary. Charges rely upon a mix of utilization, the hardware/OS/programming/arranging features picked by the supporter, required accessibility, excess, security, and administration alternatives.

Out of the services provided by AWS, we will be using Sage Maker, S3 (Simple Storage Service) Buckets, and Amazon EC2 (Elastic Compute Cloud). While these services are utilized for the back-end of the application, HTML will be used as the front-end to create a basic UI (User Interface) enabling a mode of communication between the client/customer and the server.

## III. Modules

There will basically be two modules implemented which are :

1. User Interface
2. Sage Maker and repository

The User Interface is developed using basic HTML code which allows the user to provide their query in simple English sentences. The user also has the provision to choose whether he/she wants a code snippet or an entire program corresponding to his/her query. This input is sent to the Machine Learning engine from the html page where the words are tokenized. The code snippet or the programs in the repository will be stored with tags associated to each of them. The tokens thus formed are compared to these tags in the repository by the ML engine. If a match is found, then the corresponding code or snippet (depending on the users' choice) is returned from the repository to the web page where it is visible to and accessible by the user.

AWS Sage Maker is a fully managed Machine Learning service. With Amazon SageMaker, developers can rapidly and effectively build and train ML models, and afterward directly deploy them into a production-ready hosted environment. It gives an incorporated Jupyter authoring notebook instance for simple access to your data sources for exploration and analysis, so you don't need to oversee servers. It additionally gives normal AI/ML algorithms that are advanced to run productively against very expansive information in a distributed environment.

**IV. Algorithms Used**

1. RNN - Recurrent Neural Networks (RNN) are a powerful and robust type of neural networks and belong to the most promising algorithms out there currently as they are the only ones with an internal memory. A recurrent neural network (RNN) was designed to work with sequence prediction problems. It may include one-to-one, one-to-many or many-to-many.[11][12].
2. NMT - Neural Machine Translation is a way to deal with machine translation that utilizes a large artificial neural system to anticipate the probability of a succession of words, commonly demonstrating whole sentences in a solitary coordinated model. In other words, Neural Machine Translation (NMT) is an approach to machine translation that utilizes an expansive artificial neural network system to anticipate the probability of a grouping of words, commonly displaying whole sentences in a solitary incorporated model.[4][5][6][7].

**V. Architecture**

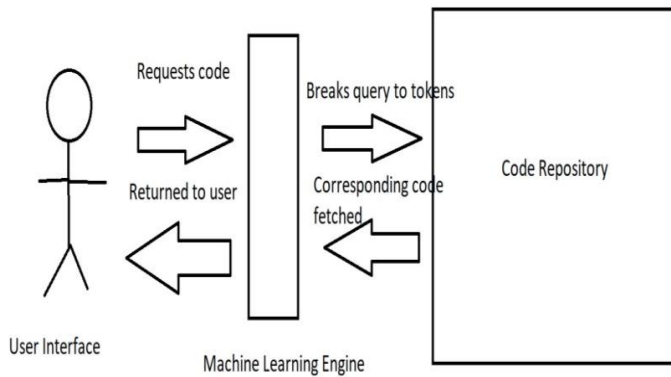

Fig 1. Architecture Diagram

From the above diagram, we can see how this system works. The user first enters his/her query in simple English terms such as “I need a code to print basic Hello World using Struts”. Along with this, the user specifies whether he/she is expecting a code snippet or an entire project. This query or input is sent from the User Interface to the Machine Learning Engine where the algorithms mentioned are applied. These algorithms are used so that the input given by the user is broken down or tokenized into individual tokens. These tokens are then compared to the tags stored in the code repository. If a match is found, then the code snippet or its link to the zip file (depending on the input) corresponding to that tag is returned to the user. If the user requires an entire project, a link will be returned as the output from which the developer can download the project in a zip file format.

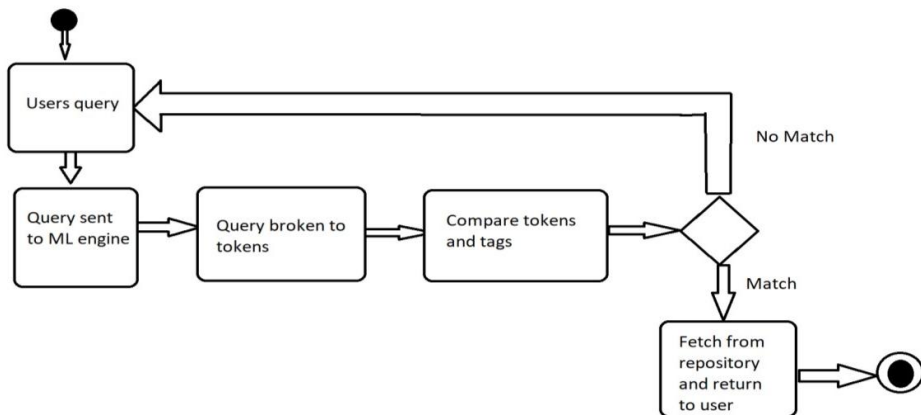

Fig 2. UML Diagram

## VI. Drawbacks

A few drawbacks of this implementation include:

1. Training time – as the data in the repository must be large, the model has to be trained several times so that it understands which code snippet or program the user is expecting
2. Limited time
3. Repetitive code
4. As of now the application can only retrieve snippets effectively.
5. Projects are imported externally from websites
6. More time and data are required to improve the text tokenization in the application.

## VII. Conclusion

The conclusion of this application will help developers around the globe to find optimized code/projects and reduce the development time which results in more quality products in the market. This allows us to iterate and release more applications and software into the market. Currently we are maturing this application to be deployed to all of its developers. More features can be added to the system as and when required so develop it further. The Machine Learning engine is able to learn on its own from the past experiences and from the feedback provided. The engine constantly learns so that it can improve itself and yield more precise program or code snippets to the user.

## VIII. Scope for Future Work

1. Planning to use MAVEN to create and send java projects directly without the help of external websites.
2. Planning to include the feedback textbox for improved prediction of tokens.
3. Providing an ability to invoke the aid of a chatbot like Google Assistant
3. Addition of adding code for other languages such as Python, C++, etc.
4. Provisioning features of analytics to get more data on the demand of code and requirements of the users.
5. Creation of project templates from user requirements

## IX. Acknowledgements

I would like to thank Mr. Vinit (Assistant Professor), Mrs. Chamundeeswari and Mr. Arun Nehru (Assistant Professors and Project Coordinators) for helping me in completing this research paper by providing aid and suggestions in every aspect related to this research.

I would also like to thank the company UST-Global for providing me this internship and the opportunity to research in this field. I would also like to convey my regards to our mentor (Mr. Jayaraj Chandrasekaran) at UST-Global, in specific, for providing us with all the required resources and providing inputs and suggestions often to make this system better and also my co-intern (Ashwath) who has worked with me in doing this research and implementation of the same.

## X. References

1. Katsumata, S., Matsumura, Y., Yamagishi, H., & Komachi, M. (2018). Graph-based Filtering of Out-of-Vocabulary Words for Encoder-Decoder Models. arXiv preprint arXiv:1805.11189.
2. Hempel, B. CONTEXT-SENSITIVE PREDICTION OF HASKELL TYPE SIGNATURES FROM NAMES.
3. Ellis, K., Solar-Lezama, A., & Tenenbaum, J. (2015). Unsupervised learning by program synthesis. In Advances in neural information processing systems (pp. 973-981).
4. Chen, J., Zhang, X., Wu, Y., Yan, Z., & Li, Z. (2018). Keyphrase generation with correlation constraints. arXiv preprint arXiv:1808.07185.
5. Papagiannopoulou, E., & Tsoumakas, G. (2018). Local word vectors guiding keyphrase extraction. Information Processing & Management, 54(6), 888-902.
6. Zhang, Y., & Xiao, W. (2018). Keyphrase Generation Based on Deep Seq2seq Model. IEEE Access, 6, 46047-46057.
7. Witten, I. H., Paynter, G. W., Frank, E., Gutwin, C., & Nevill-Manning, C. G. (2005). KEA: Practical Automated Keyphrase Extraction. In Design and Usability of Digital Libraries: Case Studies in the Asia Pacific (pp. 129-152). IGI Global.
8. Joorabchi, A., & Mahdi, A. E. (2013). Automatic keyphrase annotation of scientific documents using Wikipedia and genetic algorithms. Journal of Information Science, 39(3), 410-426.

9. Joshi, A., & Motwani, R. (2006, December). Keyword generation for search engine advertising. In Sixth IEEE International Conference on Data Mining-Workshops (ICDMW'06) (pp. 490-496). IEEE.
10. Abhishek, V., & Hosanagar, K. (2007, August). Keyword generation for search engine advertising using semantic similarity between terms. In Proceedings of the ninth international conference on Electronic commerce (pp. 89-94). ACM.
11. Ying, Z., & Shi, X. (2001). An RNN-based algorithm to detect prosodic phrase for Chinese TTS. In 2001 IEEE International Conference on Acoustics, Speech, and Signal Processing. Proceedings (Cat. No. 01CH37221) (Vol. 2, pp. 809-812). IEEE.
12. Nachmani, E., Marciano, E., Burshtein, D., & Be'ery, Y. (2017). RNN decoding of linear block codes. arXiv preprint arXiv:1702.07560.
13. He, D., Xia, Y., Qin, T., Wang, L., Yu, N., Liu, T. Y., & Ma, W. Y. (2016). Dual learning for machine translation. In Advances in Neural Information Processing Systems (pp. 820-828).
14. Wen, X., Shao, L., Xue, Y., & Fang, W. (2015). A rapid learning algorithm for vehicle classification. Information Sciences, 295, 395406.

---

# Vehicle Accident and Anti-Theft Tracking System Based on Internet of Things

<sup>1</sup>S Mownica, <sup>2</sup>P Annceline, <sup>3</sup>R Ramya, <sup>4</sup>M Indumathy

<sup>1,2,3</sup>Student, CSE, SRM Institute of Science and Technology, Chennai, India

<sup>4</sup>Faculty, CSE, SRM Institute of Science and Technology, Chennai, India

---

**ABSTRACT:** *As the quantity of urban vehicle grows apace, vehicle accident and vehicle larceny has become a shared concern for all voters. However, gift accident and anti-theft systems lack the trailing and observance perform. The vehicle accident and anti-theft trailing system supported web of things is intended during this article, which may give well-rounded active service for the house owners. once the automobile met with AN accident or taken, the measuring device sensors, Hall-Effect detectors and rev sensor mounted within the vehicle area unit triggered, and GSM module can send the emergency message with the assistance of GPS module to the close police office and additionally the individual person, so house owners and police will check the position and standing of the vehicle within the webpage. this technique uses IOT to show all the main points within the webpage that is a lot of convenient and versatile than alternative existing systems.*

**Keywords:** *Vehicle accident and anti-theft system, measuring device, Hall impact and rev detector, GPS, GSM.*

---

## 1. Introduction

In our busy life transportation is very vital. Rapid increase in demand for transport, is necessary to secure and resolve exploitation. Major issues we come across are vehicle theft and road accidents. To avoid these situations and to help and make public to feel more secured a system has been proposed by using the developed and advanced technologies (devices)

Like GPS, GSM

GPS receives the signal from the satellite and it is used to track the position that is the latitude and longitude of a vehicle. Here GSM is used for the notification purpose which will give an alert message about the situation of a vehicle. It is a microcontroller- based system. This is applicable in any situation, anytime, anywhere, that is worldwide. In this system there is only one GPS is used with two-way communication using GSM. As per an international journal of technology, engineering and applications (IJCEA) vol3, no3, Gregorian calendar year 2013, this project application was not restricted and adding on to it, more development was included like (finding the distance between the two stations). This application is as follows;

easy to use effectively installable effectively open.

It is a html-based application. This application is used to find or identify the position of a vehicle it might be an accident or a theft, by using GPS and GSM anywhere, at anytime

## Objectives

The main Objective is to style construct and check a GSM and GPS based mostly accident and anti-theft trailing system which will be wont to improve the performance of accident trailing and automobile security device. once either the measuring device or the hall impact detector detects ANy amendment within the vehicle an at once alert message are going to be send to the owner and to the close police office with the assistance of GSM and GPS module and have the choice to change of the vehicle with the assistance of SMS which may be send from the house owners mobile.

In order to attain the objectives of the project, the subsequent works were administrated. Design and develop the hardware of the planned system

Develop an impact program of the planned system Design and develop IOT based mostly security system

Conduct acceptable check for the planned system

## Related Works

As the vehicle population is steadily increasing the management of vehicles become essential. Focus is need to prevent theft and accidents. Research has been done on antitheft modules like hand wheel, electronic alarm etc.

Ei.medani.w.: ai-omar et al describes true timing trail system gives a clear location of vehicle with low value by implementing gm862 cellular quad band module

Server is to observe with a graphical program on web site which is developed through Microsoft SQL 2003 and asp.net. this gives exact vehicle location on a specific map. Also the paper provides info of speed, millage etc of the vehicle.

Hu jian-ming:li jii: guang-hue describes an automobiles antitheft system of GSM and GPS modules which develops the exploitation high speed mixed kind c8051f120 single chip.

The vibration detector is used to detect the vehicle. The framework stays with car proprietor through GSM module for the security and dependableness of car.

Fleischer,pb lorn nelson describes the development and preparation of GPS based vehicle trailing and alert system. Technique permits to trace the vehicle and provide security for heist and accident.

Le tein t vu phung describes a system that supports the GPS and GSM a model for routing and trailing with mobile vehicle during the outdoor atmosphere.

The framework incorporates the compass sensor yas529 of Yamaha organization and quickening agent sensor kxsc72050 of KOI relative quantity organization to a mass moving direction of a vehicle. The system can acquire positions of the vehicle via GPS receiver and inform supervising center by SMSor GPRS service. The center uses kit that support GSM techniques wmp100 of the wave com company.

### Proposed System

Here in our project we've IOT server. This facilitate to trace the vehicle oftentimes within the webpage.

In our system we have a tendency to even have GPS and GSM that is employed to send message to the owner and therefore the close police office once the automobile is taken or met with accident.And all the information are going to be keep within the IOT cloud for future references. We can additionally stop the engine if the vehicle met with accident or its taken with the assistance of single message.

### System Architecture

It consists of two units among them one is sending aspect (unit of the vehicle) and alternative is observance aspect

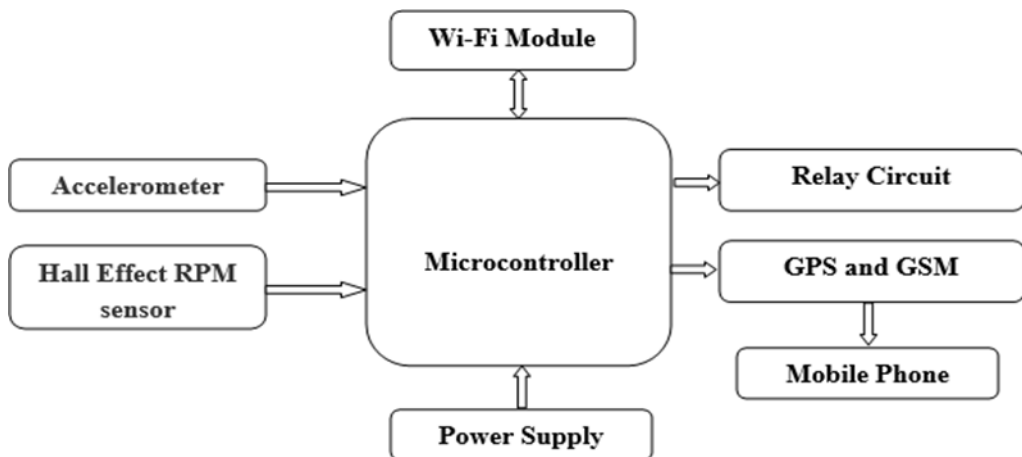

The farmers will register in the website with their own details like username, password, contact details, address details. The admin will verify the details and approved. Then only farmers can sign in and ask for a query with expert. The farmers can also query about the fertilizer and also much related information about the agriculture.

### Global Positioning System

Modules of GPS area unit highly used for navigation, time, positioning, and alternative functions. From the satellites GPS signal receives the placement values. GPS offers information:

- Transmission time of message
- Position



## Global System for Mobile

It is a remote modem that works with a GSM remote system.. The information sending and receiving is employed by the electronic GSM equipment . SIM three hundred may be a engine of tri- band GPRS/GSM.

## Microcontroller

The Arduino Uno board is a microcontroller dependent on the ATmega328. It has 14 propelled data/yield sticks in which 6 can be used as PWM yields, a 16 MHz terminated resonator, an ICSP header, a USB affiliation, 6 straightforward wellsprings of information, a power jack and a reset catch. This contains all the required help required for microcontroller

## Measuring Device Sensor

The estimating gadget Senor is utilized to watch the situation of arm or body of the patient. In the event that any unforeseen correction inside the arm or body of the patient the estimating gadget indicator worth furthermore various, and individuals esteems region unit sent to the specialist with the help of IOT.

## Corridor Effect Sensor

A Hall Effect sensor is a gadget that is utilized to quantify the size of an attractive field. Its yield voltage is straightforwardly corresponding to the attractive field quality through it. Corridor Effect sensors are utilized for vicinity detecting, situating, speed identification, and current detecting applications

## Hardware Design

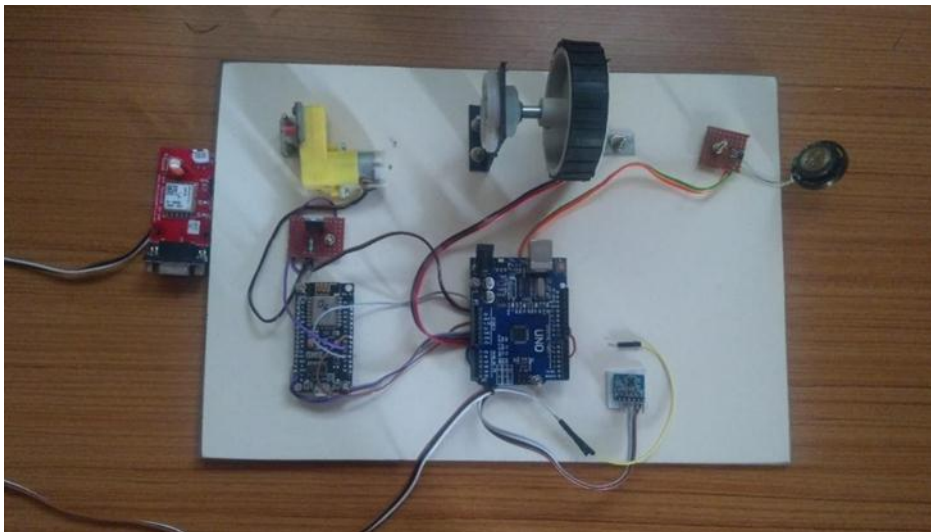

In this 40 pin ATmega16 microcontroller is used. the heart of the project is ATmega16 microcontroller which is used for interfacing. Wi-Fi module is used for data transmission and reception. The Accelerometer sensor is used to detect the position of the vehicle. Here we are using relay circuit to switch ON and switch OFF the engine. Relay is also called switch. a sequential correspondence between the microcontroller, GPS and GSM modem utilized RS-232 convention

## Result and Output

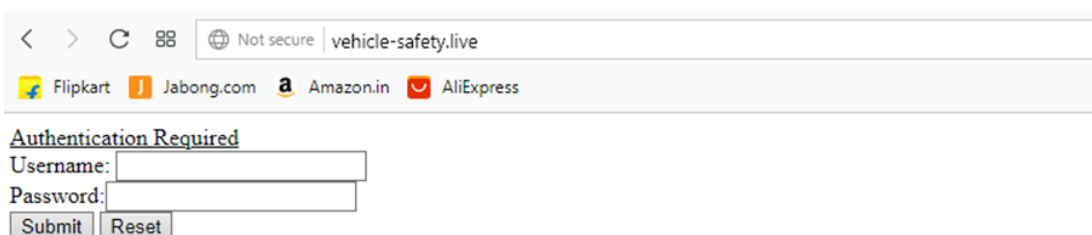

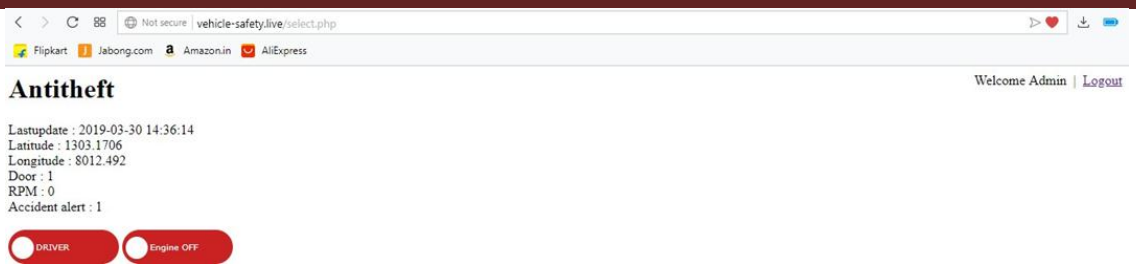

## Conclusion

This project is to demonstrate the utilization of GSM and GPS for the safety and monitoring of vehicles by studying its whereabouts and movements. Now-a-days the vehicle theft is on the increase and this system will help the owner as well as the investigating agency to easily locate the vehicle

This will lead to curtail offenders. This system can be extended to conveyance movement planning and firefighting administration

## Acknowledgement

The project was guided by MRS Indumathy , SRM INSTITUTE OF SCIENCE AND TECHNOLOGY.

## References

1. El-Medany,W.;Al-Omary,A.;Al-Hakim,R.;Al-Irhayim,S.;Nusaif,M., "A Cost Effective Real-Time Tracking System Prototype Using Integrated GPS/GPRS Module," Wireless and Mobile Communications (ICWMC), 2010 6th International Conference on, vol.,no.,pp.521,525,20-25 Sept.2010
2. Hu Jian-ming; Li Jie; Li Guang-Hui, "Automobile Anti-theft System Based on GSM and GPS Module," Intelligent Networks and Intelligent Systems (ICINIS), 2012 Fifth International Conference on , vol., no., pp.199,201, 1-3 Nov. 2012
3. Nagaraja, B. G.; Rayappa, R.; Mahesh, M.; Patil, C.M.; Manjunath, T. C., "Design & Development of a GSM Based Vehicle Theft Control System," Advanced Computer Control, 2009. ICACC '09. International Conference on , vol., no., pp.148,152, 22-24 Jan. 2009
4. Fleischer, P.B.; Nelson, A.Y.; Sowah, R.A.; Bremang, A., "Design and development of GPS/GSM based vehicle tracking and alert system for commercial inter-city buses," Adaptive Science & Technology (ICAST), 2012 IEEE 4th International Conference on , vol., no., pp.1,6, 25-27 Oct. 2012

# An Efficient Optical Communication Technique Using Mimo and OFDM Along With Generalized LED Index Modulation

S. Priyadharshini

Student

ECE (IV year)

SRM IST, Chennai, India

**ABSTRACT:** In the next era of wireless systems, VLC, that is, Visible Light Communications has become a latest technology. For MIMO and OFDM-based VLC systems, an LED index modulation method is proposed in this paper. The technique presented averts the classic spectrum efficiency losses that arise in OFDM. The loss avoidance is attained by way of spatial multiplexing combined with index modulation of LED. Correspondingly, the real and imaginary parts of the time-domain complex OFDM signals are taken apart initially, and then the arising bipolar signals are transmitted through a channel (VLC) by way of encoding the information within LED indices. Also, the performance analysis of the system is provided. In addition, two receiver designs, for frequency-flat or frequency-selective channel conditions are suggested. It is demonstrated by means of MATLAB simulations that this scheme produces markedly better BER versus SNR performance than the present MIMO-OFDM systems using VLC that employ the same quantity of transmitter and receiver units.

**Keywords:** Optical, OFDM, MIMO, orthogonal, VLC, MAP estimator.

## 1. Introduction

400–800 nm is the operating wavelength range of VLC systems in general. Hence, they can be the key for interior mobile communication. This is because the present infrastructure can be reused, and consequently communication systems can be adjoined. Inter-symbol interference (ISI), which is generated by frequency selectivity can be combatted by OFDM. However, it is futile to try to transmit the signals without any alterations because of their bipolarity. In index modulation approaches the index of the constituting sections of selected communications systems are used to send extra data bits and they offer more degree of freedom to substitute for the phase dimension loss. The typical index modulation method is spatial modulation (SM), which is used for MIMO-VLC systems. In this project, in frequency-flat and frequency-selective channels, two 4x4 MIMO optical OFDM systems are made to operate. The names of the two proposed schemes/techniques are GLIM-OFDM and extended GLIM-OFDM (e-GLIM-OFDM), where e-GLIM-OFDM operates over frequency-selective channels and is a variant of GLIM-OFDM.

## Frequency-flat channel employed for GLIM-OFDM

Figure 1 depicts the block representation of the transceiver of GLIM-OFDM in frequency-flat multiple-input-multiple-output channels. The number of OFDM subcarriers is given by  $N$  and the size of the signal sequence is given by  $M$ , as in M-QAM. Here, 16-QAM is used. The OFDM modulator in the studied method directly handles the frequency-domain complex OFDM frame with no need of Hermitian symmetry. Hermitian symmetry is the means to get a real-valued time-domain signal [2]. It is a unique type of OFDM called discrete multitone (DMT). Once the conversion from P/S is done, in the beginning, the real and imaginary components of every one of the complex time-domain OFDM signal  $x_k$ , where  $k=0,1,\dots,N-1$ , are separated as  $x_k = x_{k,R} + j x_{k,I}$ . Then, positive-negative (+/-) separators treat the emerging real bipolar signals to derive positive real-valued signals as

$$\begin{aligned} x_{k,R}^+ &= \begin{cases} x_{k,R} & \text{if } x_{k,R} > 0 \\ 0 & \text{if } x_{k,R} < 0 \end{cases} & x_{k,R}^- &= \begin{cases} 0 & \text{if } x_{k,R} > 0 \\ -x_{k,R} & \text{if } x_{k,R} < 0 \end{cases} \\ x_{k,I}^+ &= \begin{cases} x_{k,I} & \text{if } x_{k,I} > 0 \\ 0 & \text{if } x_{k,I} < 0 \end{cases} & x_{k,I}^- &= \begin{cases} 0 & \text{if } x_{k,I} > 0 \\ -x_{k,I} & \text{if } x_{k,I} < 0 \end{cases} \end{aligned} \quad (1)$$

In the above equations,  $n_T$  and  $n_R$  express the number of transmitter and receiver entities. Due to the lack of need of Hermitian symmetry,  $\log_2 M$  becomes the spectral efficiency of this scheme.  $x_{+k,R}$ ,  $x_{-k,R}$ ,  $x_{+k,I}$  and

$x_{k,l}$  are the positive and real-valued OFDM time samples propagated by the  $R \times 4$  optical MIMO channel (given by  $\mathbf{H}$ ) as  $y = \mathbf{H}\mathbf{x} + \mathbf{n}$  (2).  $\mathbf{x} \in \mathbb{R}^{4 \times 1}$  stands for the transmitted signal vector of GLIM-OFDM as

$$\mathbf{x} = [x_{k,R}^+ \quad x_{k,R}^- \quad x_{k,I}^+ \quad x_{k,I}^-]^T \tag{3}$$

where the various elements of  $\mathbf{x}$  denote the signals emitted from the LEDs. In this work, 4 receive units are taken. LEDs are assumed to be functioning within their dynamic range. The MIMO optical channel of the  $4 \times 4$  system is given by the matrix in equation (4) given below.

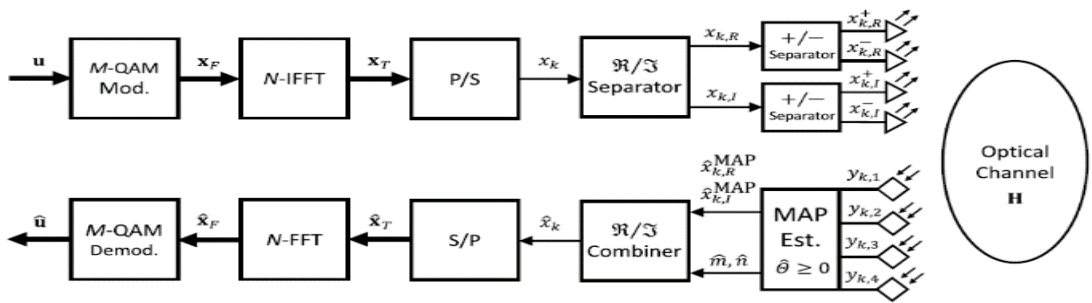

Fig. 1.  $4 \times 4$  MIMO system block diagram for GLIM-OFDM (Source: Ref [1])

$$\mathbf{H} = \begin{bmatrix} h_{1,1} & h_{1,2} & h_{1,3} & h_{1,4} \\ h_{2,1} & h_{2,2} & h_{2,3} & h_{2,4} \\ h_{3,1} & h_{3,2} & h_{3,3} & h_{3,4} \\ h_{4,1} & h_{4,2} & h_{4,3} & h_{4,4} \end{bmatrix} \tag{4}$$

where the channel gain of the wireless optical link between the LED ( $t$ ) and the PD ( $r$ ) is given by  $h_{r,t}$ , where ( $t, r$ ) can be given as  $\in \{1, 2, 3, 4\}$ . The average SNR at the receiver is considered as

$$\text{SNR}_{\text{Rx}} = \frac{P_{\text{Rx}}^{\text{elec}}}{\sigma_n^2} = \frac{1}{\sigma_n^2} \zeta \left( P_{\text{Rx}}^{\text{opt}} \right)^2 \tag{5}$$

where, the conversion factor from electrical to optical is  $\zeta$ , equated to unity in this case, and the average electrical power received is  $P_{\text{Rx}}^{\text{elec}}$ . The average optical power received is taken as below

$$P_{\text{Rx}}^{\text{opt}} = \frac{1}{n_R} \sum_{r=1}^{n_R} \sum_{t=1}^{n_T} h_{r,t} I \tag{6}$$

where the mean emitted optical intensity is represented by  $I$ . Due to the symmetry (when  $x_{k,R}$  and  $x_{k,I} \sim N(0, 1/2)$  is considered), the four total units of  $\mathbf{x}$  possess the clipped Gaussian probability density function:

$$p_{x_{k,R(I)}}^{\pm}(v) = \frac{I}{\sqrt{\pi}} e^{-v^2} u(v) + \frac{I}{2} \delta(v) \tag{7}$$

where the unit step and Dirac delta functions are given by  $u(v)$  and  $\delta(v)$ , respectively. Subsequently, from one LED, the average electrical power emitted is obtained as

$$I = E\{x_{k,R}^{\pm}\} = \int_0^{\infty} v P_{x_{k,R}^{\pm}}(v) dv = 1/(2\sqrt{\pi}). \tag{8}$$

**Conditional MAP Estimator**

MAP estimator is mainly used for deciding the highly likely active LED pair. The received signal vector cannot possibly be forwarded directly to the OFDM demodulator, since complex valued signals need to be built first to acquire the OFDM block's frequency-domain estimate. Zero-forcing (ZF) equalizer can be a feasible answer to the problem of estimation in (2) [1]. This produces the estimate of  $\mathbf{x}$  as

$$\hat{\mathbf{x}}^{ZF} = \mathbf{H}^{-1} \mathbf{y}. \tag{9}$$

By multiplying  $\mathbf{y}$  with  $\mathbf{H}^{-1}$ , the ZF estimator can considerably increase noise power, even though it has a simple design. In addition, it may also generate negative estimates. To surmount these disadvantages of the ZF estimator, for the GLIM-OFDM scheme, a MAP estimator is proposed, by considering the information available for  $\mathbf{x}$ .

$\mathbf{H} = [\mathbf{h}_1 \mathbf{h}_2 \mathbf{h}_3 \mathbf{h}_4]$  denotes the channel matrix. The observed signals provided in (2) are revised as

$$\mathbf{y} = \mathbf{h}_m \bar{x}_{k,R} + \mathbf{h}_n \bar{x}_{k,I} + \mathbf{n} \tag{10}$$

where  $n \in \{3, 4\}$  and  $m \in \{1, 2\}$ . It can be demonstrated that  $x_{k,R}$  and  $x_{k,I}$  possess a half-normal folded Gaussian distribution with p.d.f as

$$P_{\bar{x}_{k,R}(I)}(v) = \frac{2}{\sqrt{\pi}} e^{-v^2} u(v). \tag{11}$$

The conditional MAP estimates of  $x_{k,R}$  and  $x_{k,I}$ , for the pair (m,n), can be written as

$$\left( \tilde{x}_{k,R}^{(m,n)}, \tilde{x}_{k,I}^{(m,n)} \right) = \arg \max_{\bar{x}_{k,R}, \bar{x}_{k,I}} p(\bar{x}_{k,R}, \bar{x}_{k,I} | \mathbf{y}) \tag{12}$$

where  $p(\bar{x}_{k,R}, \bar{x}_{k,I} | \mathbf{y})$  represents the p.d.f. of  $x_{k,R}$  and  $x_{k,I}$ , conditioned on  $\mathbf{y}$ . After some modifications, (12) can be obtained as

$$\left( \tilde{x}_{k,R}^{(m,n)}, \tilde{x}_{k,I}^{(m,n)} \right) = \arg \min_{\bar{x}_{k,R}, \bar{x}_{k,I}} M^{MAP}(m, n, \bar{x}_{k,R}, \bar{x}_{k,I}). \tag{13}$$

where the MAP estimation metric, MMAP is defined as

$$M^{MAP}(m, n, \bar{x}_{k,R}, \bar{x}_{k,I}) = \|\mathbf{y} - \mathbf{h}_m \bar{x}_{k,R} - \mathbf{h}_n \bar{x}_{k,I}\|^2 + 2\sigma_w^2 (\bar{x}_{k,R}^2 + \bar{x}_{k,I}^2). \tag{14}$$

(14) is simplified by algebra as

$$M^{\text{MAP}}(m, n, \bar{x}_{k,R}, \bar{x}_{k,I}) = A\bar{x}_{k,R}^2 + B\bar{x}_{k,I}^2 + C\bar{x}_{k,R} + D\bar{x}_{k,I} + E\bar{x}_{k,R}\bar{x}_{k,I} \tag{15}$$

$$A = \mathbf{h}_m^T \mathbf{h}_m + 2\sigma_w^2 \quad B = \mathbf{h}_n^T \mathbf{h}_n + 2\sigma_w^2$$

$$C = -2\mathbf{y}^T \mathbf{h}_m \quad D = -2\mathbf{y}^T \mathbf{h}_n$$

where  $E = 2\mathbf{h}_m^T \mathbf{h}_n$ . (16).

By obtaining the derivative of MMAP with respect to  $\bar{x}_{k,R}$  and  $\bar{x}_{k,I}$  and then equating to zero results in the MAP estimates of real and imaginary parts as

$$\bar{x}_{k,R}^{(m,n)} = \left[ \frac{2BC - ED}{E^2 - 4AB} \right]^+, \quad \bar{x}_{k,I}^{(m,n)} = \left[ \frac{2AD - EC}{E^2 - 4AB} \right]^+ \tag{17}$$

**Algorithm 1** Conditional MAP Estimator

- 1: for  $m = 1 : 2$  do
- 2:   for  $n = 3 : 4$  do
- 3:     Estimate,  $\bar{x}_{k,R}^{(m,n)}$  and  $\bar{x}_{k,I}^{(m,n)}$  values from (17)
- 4:     Estimate,  $(\bar{m}, \bar{n})$  indices from (18)
- 5:   end for
- 6: end for
- 7: Combination of symbols:  $\pm \bar{x}_{k,R}^{(\bar{m}, \bar{n})} \pm j \bar{x}_{k,I}^{(\bar{m}, \bar{n})}$  via  $(\bar{m}, \bar{n})$ .

The steps involved in the MAP estimator are given are given in Algorithm 1. Subsequent to this stage, the standard processing steps of OFDM such as S/P conversion, FFT, followed by M-ary demodulation are carried out.

**Frequency-selective channel employed for GLIM-OFDM**

A slightly modified GLIM-OFDM scheme, especially for frequency-selective channels is named as extended GLIM-OFDM (e-GLIM-OFDM). OFDM technique inherently copes with multi-path channel characteristics that usually arise when data rate is high. Fig. 2 presents e-GLIM-OFDM scheme's block diagram.

After index modulation of LED is performed, the time-domain OFDM frame is elongated into four vectors, contrary to the flat VLC channels of GLIM-OFDM scheme, and a cyclic prefix is attached to the starting of each vector to be transmitted. From each of the PDs,  $(N + L_{cp}) \times 1$  real-valued signal vectors are acquired at the receiver side.  $\Psi_{CP} = [y_1 \ y_2 \ y_3 \ y_4]^T \in \mathbb{R}^{4(N+L_{cp}) \times 1}$  is the overall received signal vector. Finally, after effecting IFFT for each data stream separately, the estimates of the transmission vectors are obtained and the indices of the active LEDs are worked out by the comparison of corresponding elements of  $(\mathbf{x}_R^+, \mathbf{x}_R^-)$  and  $(\mathbf{x}_I^+, \mathbf{x}_I^-)$  vector pairs for every subcarrier. BER performance of this scheme is investigated later.

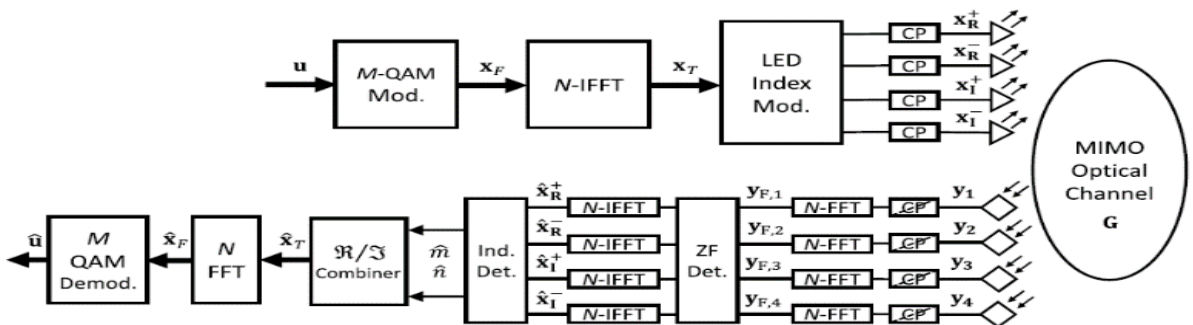

Fig. 2. 4x4 MIMO system block diagram for e-GLIM-OFDM (Source: Ref [1])

### Physical vlc channel models

CIR evaluation in VLC systems is a critical task. In order to reduce the transmission power, the loss in optical channel should be limited. To calculate the power received, the channel gains must be gotten with zero-order reflection (for LOS path). Below formula is for channel gains (analytical)

$$h_{r,t} = \begin{cases} \frac{(m+1)A_r R_p}{2\pi d_{r,t}^2} \cos^m(\phi_{r,t}) \cos(\psi_{r,t}), & 0 \leq \psi_{r,t} \leq \Psi_{1/2} \\ 0, & \psi_{r,t} > \Psi_{1/2} \end{cases} \quad (18)$$

where, distance between each pair of LED and PD is given by  $d_{r,t}$ ,  $A_r$  stands for PD area, the responsivity of the PD is taken as  $R_p$  and presumed as unity. Furthermore, the irradiance angle and the incidence angle are given by  $\phi_{r,t}$  and  $\psi_{r,t}$ , respectively.

### VLC MIMO channels in frequency-flat type

Now, a  $4 \times 4$  MIMO-VLC system is considered to be functioning in a  $5 \text{ m} \times 5 \text{ m} \times 3 \text{ m}$  room. Four LED luminary setups, spaced at 2m apart on the ceiling, are taken. The view angle of each LED chip is adopted as  $120^\circ$ .  $85^\circ$  denotes the field-of-view semi-angle (FOV) of the PD and  $1 \text{ cm}^2$  as its area. The two configurations presented in Fig. 3 are Configuration A (PDs at the centre of table with equal spacing of 0.1 m) and Configuration B (PDs in the corners of table with equal spacing of 0.8 m).

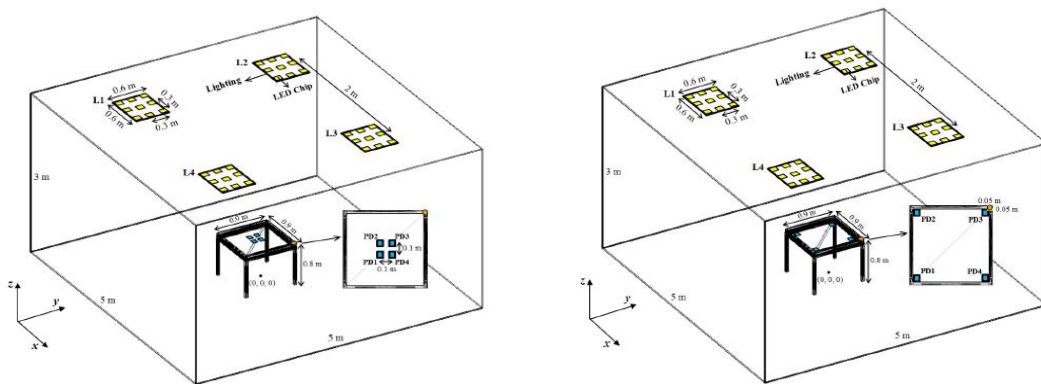

Fig. 3. Configurations A (top) and B (bottom)(Source: Ref [1])

In Config B the detectors are present at the corners of the table. So, they are subjected to higher scattering from the walls. Hence, the difference between analytical channel gains and physical channel gains is higher with regard to Config A.

### VLC MIMO channels with frequency selectivity

In this section, the process to acquire the physical multi-path VLC channel characteristics is briefed. Surrounding aspects such as people, furniture design, their position and sources/detectors have a crucial impact on reflection and refraction patterns. For higher order reflections, all the above parameters are considered and the frequency-selective CIRs are obtained similar to the frequency-flat scenario and are given on the right. Additionally, the number of VLC channel vector taps is taken as 6, same as the cyclic prefix length.

### Computer simulations and performance analysis

#### Performance of GLIM-OFDM

The comparison of BER performance between GLIM-OFDM scheme and existing reference schemes in regard to average electrical SNR received is done. Here, the curves of performance are provided for 2, 3 and 4 bit/sec/Hz (spectral efficiency values) in different channel configurations of VLC, in which the subcarriers count is taken as 256.



Fig. 4 and 5 give BER performance curves for Config A (low diagonality). It can be seen that GLIM-OFDM performs more efficiently than the other reference systems. GLIM-OFDM has superior BER performance where the channel matrix is near diagonal, since the BER performance depends on the correlation LOS and NLOS elements of the channel matrix. Diagonal refers to the strength of correlation between the columns and rows of the channel matrix.

$$\begin{aligned}
 \mathbf{g}_{1,1} &\approx 10^{-8}[2.5107 \ 1.3290 \ 4.2021 \ 5.2421 \ 0.9347 \ 0.4133]^T, \\
 \mathbf{g}_{1,2} &\approx 10^{-8}[13.869 \ 4.3617 \ 2.3950 \ 0.4165 \ 0.5569 \ 0.2852]^T, \\
 \mathbf{g}_{1,3} &\approx 10^{-8}[0.2502 \ 2.5546 \ 1.1561 \ 1.0689 \ 0.6099 \ 0.5570]^T, \\
 \mathbf{g}_{1,4} &\approx 10^{-8}[16.220 \ 4.4067 \ 3.2170 \ 1.6950 \ 0.7968 \ 0.2426]^T, \\
 \mathbf{g}_{2,1} &\approx 10^{-8}[3.8362 \ 1.2489 \ 1.9733 \ 2.8366 \ 1.0588 \ 0.7232]^T, \\
 \mathbf{g}_{2,2} &\approx 10^{-8}[257.69 \ 9.0081 \ 1.7300 \ 2.9421 \ 2.1824 \ 0.2493]^T, \\
 \mathbf{g}_{2,3} &\approx 10^{-8}[0.1758 \ 3.5579 \ 5.0503 \ 1.2249 \ 0.6706 \ 0.2167]^T, \\
 \mathbf{g}_{2,4} &\approx 10^{-8}[127.47 \ 10.155 \ 0.1015 \ 3.5622 \ 2.7293 \ 0.7926]^T, \\
 \mathbf{g}_{3,1} &\approx 10^{-8}[130.23 \ 8.0788 \ 3.1797 \ 1.7479 \ 1.7082 \ 0.3576]^T, \\
 \mathbf{g}_{3,2} &\approx 10^{-8}[0.1044 \ 0.1007 \ 0.6197 \ 1.5607 \ 0.5474 \ 0.2261]^T, \\
 \mathbf{g}_{3,3} &\approx 10^{-8}[0.4087 \ 0.1467 \ 3.0861 \ 2.5029 \ 0.3504 \ 0.5618]^T, \\
 \mathbf{g}_{3,4} &\approx 10^{-8}[0.4368 \ 2.9358 \ 2.1694 \ 2.1221 \ 0.5044 \ 0.4179]^T, \\
 \mathbf{g}_{4,1} &\approx 10^{-8}[0.3185 \ 6.2577 \ 3.0124 \ 0.9103 \ 0.9437 \ 0.4686]^T, \\
 \mathbf{g}_{4,2} &\approx 10^{-8}[5.1500 \ 1.0373 \ 1.9243 \ 0.5546 \ 0.1538 \ 0.0613]^T, \\
 \mathbf{g}_{4,3} &\approx 10^{-8}[0.4588 \ 1.9667 \ 3.4924 \ 1.6399 \ 0.6069 \ 0.1007]^T, \\
 \mathbf{g}_{4,4} &\approx 10^{-8}[0.3313 \ 13.331 \ 2.8363 \ 5.8317 \ 1.4873 \ 0.3917]^T
 \end{aligned}$$

Frequency-selective CIRs

Table I – Correlation coefficient values

Configuration	r
$H_A^a$	0.0236
$H_A^p$	0.0114
$H_B^a$	0.1982
$H_B^p$	0.1777

For instance, in HaA, for SNR=46dB, BER is observed to be 0.04292 for GLIM-OFDM and 0.4615 for a reference system, say OSM-DCO. Same goes for HpA also, where for an SNR of 35dB, OSM-DCO produces 0.361 BER, while GLIM-OFDM produces only 0.1524 BER.

Fig. 6 and 7 give the BER performance curves for Config B (modest diagonality). From the results projected in these graphs, it is clear that GLIM-OFDM offers improved BER performance than any of the other schemes with the same spectral efficiency. The difference between BER performance of GLIM-OFDM with any existing system is vast. In HaB/HpB, for an SNR of 23dB, OSM-DCO generates 0.2864 BER, whereas it is just 0.004561 in GLIM-OFDM.

Comparing SNR vs. BER from Fig. 4 & 5, for a certain M value (say, M=16), the analytical channel offers better BER performance compared to the physical channel. For example, for a SNR value of 23dB, the BER observed is 0.2154 for HaA, whereas it is 0.2315 for HpA.

Similarly, taking Config B, for any value of M, say M=16, the BER in analytical channel is only slightly better than that in physical channel, due to the close correlation coefficient values between HaB and HpB. For example, for a SNR value of 22dB, the BER observed is 0.004561 for HaB, whereas it is 0.005438 for HpB.

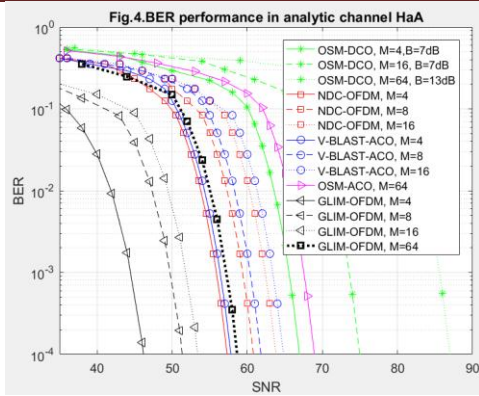

Fig. 4. BER performance comparison in HaA

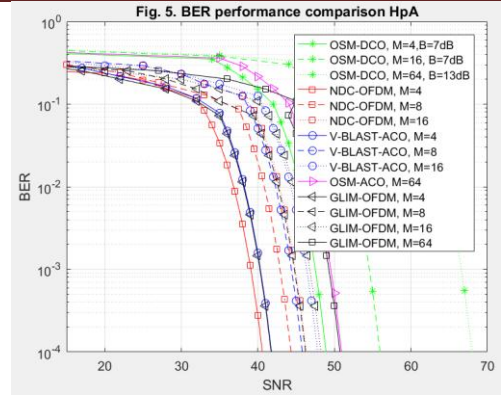

Fig. 5. BER performance comparison in HpA

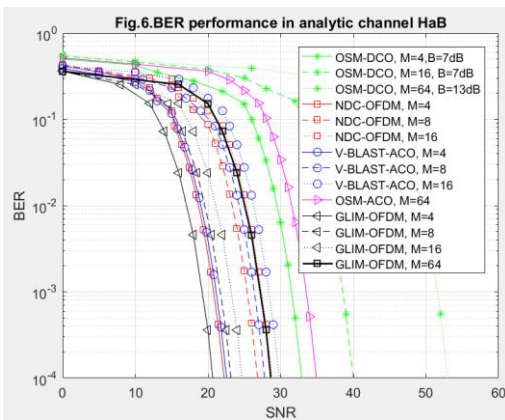

Fig. 6. BER performance comparison in HaB

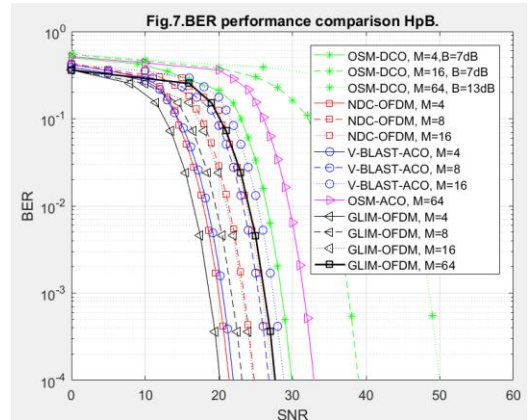

Fig. 7. BER performance comparison in HpB

### Performance of e-GLIM-OFDM

BER performance results is discussed for the e-GLIM-OFDM technique in this section. In Fig. 8, BER vs. SNR curves for the model working at 2, 3 and 4 bits/sec/Hz of spectral efficiency in MIMO channels with frequency-selectivity with 6 taps (maximum delay spread of this channel is 60ns) are given. For M=16, for an SNR value of 25dB, BER produced is 0.09474. This method can manage with relative ease both ISI as well as Inter LED Interference (ILI). From the simulated graph, it can be inferred that e-GLIM-OFDM is a viable method for multi-path VLC channels.

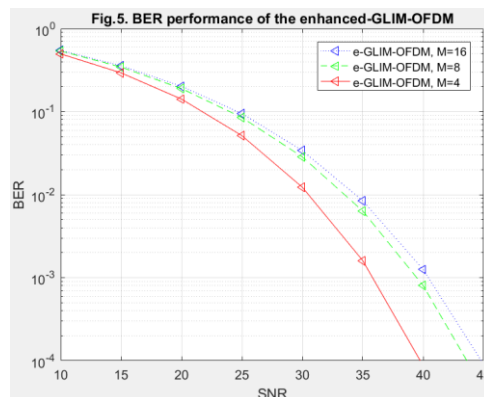

Fig. 8. BER performance of e-GLIM-OFDM

### Conclusion

VLC technology is a rapidly developing field of study for wireless communication systems. Combining its techniques with MIMO and OFDM concepts results in the advent of a new era of communication modules that provide better signal strength with minimalised error and interference issues.

In this work, a 4x4 MIMO system has been considered and developed that utilizes OFDM processing stages, as well as LED index modulation technique. This is made to operate in frequency-flat and frequency-selective channels, and corresponding performance curves are obtained and plotted for further comparison and analysis. To derive these performance curves, three different receiver arrangement scenarios are considered, say, configurations A, B and C.

From the software simulations, it is concluded that the schemes proposed through this paper perform quite similar to each other, but significantly better than any of the existing MIMO-OFDM systems.

### Acknowledgment

I would like to thank my guide for her constant support and technical knowledge imparted, and the university management for facilitating the opportunity to present this paper.

### References

1. Anil Y, Ertugrul B, Farshad M, Erdal P, Murat U and Harald H, "Optical MIMO-OFDM with generalized LED index modulation", IEEE transactions on communications, vol. 65, no. 8, August 2017.
2. Deve, dsp.stackexchange.com, Hermitian symmetry, May 2014.
3. Azza Alamir and Hamada Esmail, "Optical MIMO-TDS-OFDM with generalized LED index modulation", Wseas transactions on communications, vol. 27, 2018.
4. Ertugrul Basar, "Index modulation techniques for 5G wireless networks", IEEE communications magazine, vol. 54, issue 7, July 2016, pp. 168-175.
5. N. Showme, Anush Ramachandran, Nihal Sekhar and Ravi Shankar, "High competence MIMO-OFDM with generalized led index modulation", International journal of engineering and technology, 7 (2.31), 2018, pp. 228-280.
6. Dimitrov S and Haas H, Principles of LED light communications: Towards Networked Li-fi, Cambridge University Press, 2015.

---

# Cost Estimation and Analysis Tool for C Programming

Ram Kumar, Gautam Shetty, Kaushik Kamal Das

Department of Computer Science Engineering (4th Year)

SRM Institute of Science and Technology, Ramapuram Campus - Part, Vadapalani  
Chennai, India

---

**ABSTRACT:** Various methods are used to measure program complexities. They are mostly based on object-oriented features such as: cohesion of classes, inheritance, functions used, number of methods/classes etc. However, during implementation, a program is constructed with either procedural or object-oriented method structures. Also, it would not be wrong to say that today's idea of multiparadigm programming. After the compilation of the programs the complexity is shown in seconds and a size of the file of which the user is unaware from where it came. Due to which the end user can't understand why the program is consuming that amount of time and space. So, it helps the end user to analyze the programs more efficiently and learn more about the basic programming techniques. The model which has been discussed here shows that the complexity of the program, header files, lines of codes and all the other elements in the program has an effect in the efficiency of the code. In this paper, we have proposed a new technique to show the complexity of a program. Here, the user will get to know about iterations performed by the loops, unnecessary header files included in program and the types of variables initialized in the program and will understand the efficiency of time and space complexities.

**Keywords:** iterative, recursive, complexity, header files.

---

## 1. Introduction

There are various methods to measure the complexities of programs. The complexity of programs basically depends on the number of operands and the operators on the number of predicates of the code. Nevertheless, these measure or method do not adequately characterize the nature of complexity, since 'n' nested loops or 'n' nested 'if statements' are more complex than the series of 'n' loops or 'n' decisions coming one after another. In the previous years for measuring the complexity of the procedural program was either on the basis of its control structure or on the data which has been used.

At present in the era of advanced programming languages "object oriented" is one of the most frequently used word. In making a great system the most important thing is the reusability and extensibility of the code turns out to be the key importance. The simple programs become easier to understand (or it is much easier to understand a simpler program). Some parts can be modified later to construct other such similar programs. Engineers/mathematicians who follow object-oriented methodology said that using this new technique simplifies the professional software production which eventually decreases the enormous cost.

It is seen that for measuring the object-oriented software the object-oriented notations are used. Anyways now in modern programming languages not only the implement facilities of the object-oriented paradigm but also the languages have very strict procedural parts too. C++ programming language us one of the commonly used modern language because it uses universal and generic programming techniques such as templates, iterations, classes, traits, inheritance, etc.

Another important technique used for programming is aspect-oriented programming (statics from XEROX Palo Alto Programming and Research Centre). Aspects are used to reduce the complexity and elements cross cutting code segments for the object-oriented Java programs. Inheritance from a template class and standard library are used in C++ more often. It seems implausible to measure programs or libraries only from the one point of paradigm. As the paradigms are found too closely mixed in programs therefore the complexity of a program depends on three components:

- i. Control structure of the program
- ii. Data types of the variables being used in the program,
- iii. Connection between the data types and the control structure.

We propose a program analysis tool that calculates how complex a program is by taking different parts of program into consideration which allows user to achieve a better understanding of time complexity. First it is tested on procedural programs showing that it works well on such programs. This measure can be further employed in object- oriented programs.

## II. Components measured in proposed model

### 2.1 Header files

In computer programming, a header file can be thought of as a dictionary used by a compiler to understand the words written in the programs and decode the meaning from it. Mainly programming languages like C and C++ use this.

As we know, a computer is really powerful. But it can't think on its own. It needs all the raw data or information to be fed into to get a processed result. But it is not practical to type all the instruction repeatedly for a task, especially if we are using the same task frequently. As a solution to this, header files are used.

### 2.2 Variables used

In programming, depending on conditions or information passed to the program, a value can be changed called variable. Generally, a program consist of instruction that tells the computer its task and data being used by the program when it is running. The variables declared in the program should have a particular data type.

### 2.3 Iterations

In the field of computer programming, iteration is the repetition of a function or a process for a specific number of times or until a condition is met. When a set of instruction is executed again and again, it is called an iteration. Recursive functions also follow iteration, although in this entire function is recalled instead of repeating a process.

It can be done in C/C++ in following ways:

- for: 'for' loops is entry-controlled, it allows us to run a particular statement or lines of code for a specific number of times. This loop enables us to perform x number of steps together in a line.

Syntax:

```
for (expression a; expression b; expression c)
{//statement
// {or} blocks of statement
}
```

*expression a* is initialized, *expression b* used to terminate test, *expression c* is a modifier/update expression (can be more than just simple increment/decrement)

- while: About for loop we have seen that the number of iterations is already known, i.e. the number of times the loop block is needed to be executed is known. 'while' loops are used in a situation when we are not aware of the exact number the loop execution. The loop is terminated on the basis of the test expression.

Syntax:

```
expression a;
while (expression b)
{//statement(s)
update expression;
}
```

*expression a* is initialized, *expression b* is a test expression

- do-while: In 'do while' loops, also the loop execution is terminated on the basis of test expression. The main difference between 'do while' loop and 'while' loop is, in 'do while' loop is that the first two loops are entry controlled where the condition is tested at the beginning but in the do- while loop the condition is checked at the end of loop block. Hence, 'do while' loop is exit-controlled whereas the rest two loops are entry-controlled loops.

Syntax:

*expression a*;

do

{*//statement(s)*

update *expression*;

} while (*expression b*);

*expression a* is initialized, *expression b* is a test expression

## 2.4 Recursion

The process in which a function calls itself directly or indirectly is called recursion and the corresponding function is called as recursive function. Using recursive algorithm, some of the problems can be solved easily. In recursive program, the solution to base case is provided and solution of bigger problem is expressed in terms of smaller problems.

## III. Proposed idea

In the proposed system we take the user program as input in a text editing window which have the option of:

New: to write the program in the window

Insert: to insert a program to the application from the computer

Analyse: to analyze the program and show the output in the output window

Once the application starts analyzing it will consider the following constraints:

Header Files: At first it will check the header files added to the program. The functions related to the header files are stored the application memory. Included header files are then stored in a buffer for further references. Once the program counter come across any function related to a particular included header file then the header file is validated and given a weightage to it.

Variables: The tool will check all the variables initialized in the program and measures the memory size used by the variables. Each variable in the program is weighted according to its data types and size occupied in the memory.

Flow of Control: It will check for all types of flow control methods (i.e., for, while and do-while) and it will be weighted according the number of recursions made in the loop.

LINES OF CODE: As number of lines in the code also matters the size of the program and the memory consumed by the program. So, it will be checking the lines of code in the program.

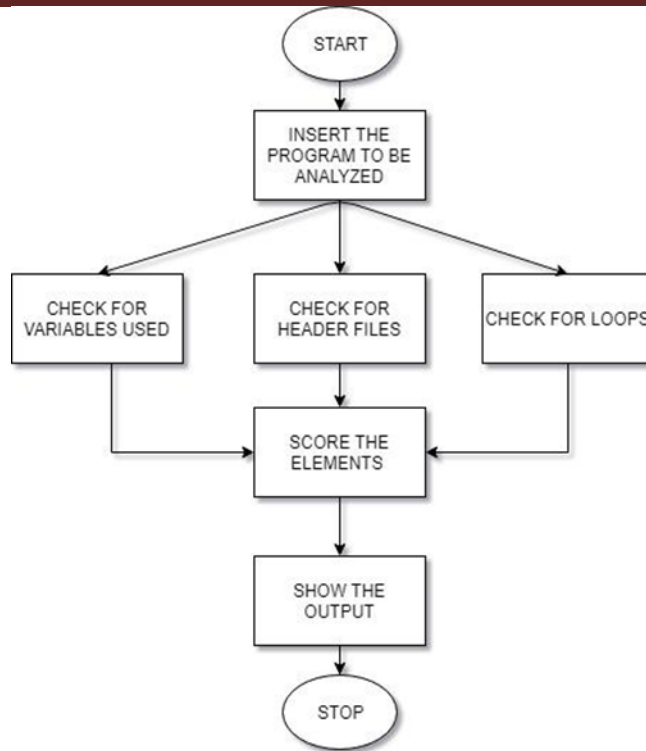

Fig 3.1: Flow Chart of Working of the Tool

### 3.1 CEAT Algorithm

If test.c is the program to be analyzed then:

Step 1: Start

Step 2: Declaration of variables ln, wi, l, n, i

Step 3: Initialization of variable i<-0

Step 4: Open C program as a text file

Step 5: Input the program into string variable ln

Step 6: Close the C file

Step 7: Traverse through ln

If ln has #include

Open the respective header file and check the presence of the function.

wi<-wi+3

If ln has operator

wi<-wi+1

If ln has variable

If variable is typedef

wi<-wi+2

Else if variable is pre-defined

wi<-wi+1

If ln[i] has emptyspace

If ln[i+1] has emptyspace

delete ln[i+1]

Else continue



Step 8: If ln has loop  
 If nested  
 $n <-(n*n)*n$   
 Else  
 $n <-n*n$

Step 9: Display weights and time complexity

Step 10: Stop

#### IV. System Architecture

The system architecture is used to explain the working of the software or module according to its principles, concepts and the characteristics which are logically related and consistent with each other. The solution architecture has the characteristics, properties and features satisfying the most possible problems or the opportunity created by the working system and the life cycle concept and the implemented through the technologies.

It is an abstract, conceptual based, global and focused to achieve the target and the working life cycle concepts of the system. System architecture also concentrates on high-end structure in the system and system elements. One architecture can be used for representing the common structures, pattern and set of requirements for similar classes and families.

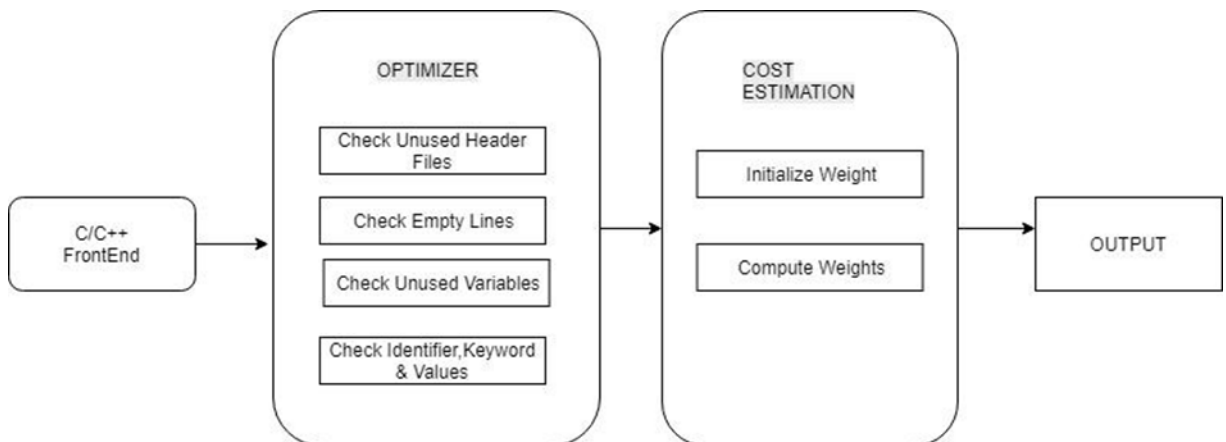

**Fig 4.1:** Architecture of the CEAT tool with its Components

The system discussed in this paper takes a compiled program as an input for it. The very first module of the system analyses the header files in being called in the program. This module is linked with all the related header files in C programming. So, when it analyses the code it checks for all the functions being used in the code and it links these functions with the header files. There some header files which is being called in the program but there is not any function used from that particular header file. Hence the module gives a suggestion to the user that this header file is not required.

The next module of the system is a lexical analyzer. Its main task is to take the program as a normal character file and differentiate all the tokens, variables, functions and the other elements in the program. Once it analyses all the elements it sorts them into different categories and assigns a cost to each and every element in the code. After which a total cost is being calculated by using the equation mentioned in the next part.

#### V. Weight Assumption

Table 1 Assumed weights for the elements

Elements	Weights
Header files	3
Single line of code	1

Elements	Weights
Predefined variables	2
User defined variables	2.5
Line in iterative loop	1
Line in recursive form	1.5

The weights have been assumed according to the generalized uses of the elements while coding by the users. The beginners while learning to code use unwanted header files commonly just in case if they might need in between the program but it's never needed so we have given a higher weight for it. The predefined variables are already present there in the compiler so it has been given a lesser weight than that of the user defined variables. Same as with the recursive and iterative lines. The iterative lines just get executed according to the limits of the loop but if the lines are in a recursive function then the compiler takes more time to execute it and even makes the processing complex. For the execution of each line in the program a weight of 1 is given so that the user tries to keep lesser lines in the code and make it compact.

If the program has:

**Case 1:** header file-h; predefined variables-p; user defined variables-u; lines in iterative loop- i; limit of the loop-l; lines of code-ln

then the estimated cost when the program has iterative loop will be:

$$EC = h*3 + p*2 + u*2.5 + i*(1*l) + 1*ln \tag{1}$$

**Case 2:** header file-h; predefined variables-p; user defined variables-u; lines in iterative loop- i; limit of the loop-l; lines of code-ln

then the estimated cost when the program has recursive form will be

$$EC = h*3 + p*2 + u*2.5 + i*(1.5*r) + 1*ln \tag{2}$$

For an example to show the working of the tool two different programs have been compared which find the square of a number. In table II the program has been written without the use of the math.h header file and the other program in table III has used the math.h header file.

Table 2 Without math.h

SRL	Code	Weight
1	#include<iostream.h>	3
2	void main()	1
3	{ int a,sq;	2*2
4	scanf("%d",&a);	1
5	sq=a*a;	1
6	printf("square of %d is %d",a,sq);	1
7	}	1
Total:	(3*1+2*2)+1*7	14

Table 3 With math.h

SRL	Code	Weight
1	#include<iostream.h>	3
2	#include<math.h>	3
3	void main()	1
4	{ int a,sq;	2*2
5	scanf("%d",&a);	1
6	sq=pow(a,2);	1
7	printf("square of %d is %d",a,sq);	1
8	}	1
Total:	(3*2+2*2)+1*8	18

## V. Implementation

For the implementation we have started with checking of header files, removing empty lines, counting the iteration of loops and identifies the variables used in the program with its size. For this the C program is first written in the notepad or the program is inserted into the notepad then the text file is saved with a different name. Once the program is run the first module checks for the unwanted header files which are not needed in the program. Following which the second module analyses the whole program lexically and assigns the weights for all the elements in the program according to the assumed weights from Table I. Once the weight is assigned the total cost is calculated with the help of the equations 1 and 2. After finding the total cost and complete analysis of the program the output is shown with all evaluated parameters and the total cost.

```
#include<stdio.h>
#include<conio.h>
#include<string.h>
void main()
{
    int a,b,c,n=0;
    char aa,bb;
    float ab,ba;
    scanf("%d",&a);
    printf(a);
    while(n>4)
    {
        while(n>5)
        {
        }
    }
    while(n<2)
    {
    }
    for(i=0;i<10;i++)
    {
        for(j=0;j<4;j++)
        {
            printf("Hello",a+b);
        }
    }
    for(m=0;m<5;m++)
    {
        printf("m");
    }
    getch();
}
```

Fig 6.1: Input Program to be Analyzed

```
| UNWANTED EMPTY LINES REMOVED ARE: |
+-----+
|          0          |
+-----+
+-----+
| NUMBER OF LINES: | COST |
+-----+
|          17          | 17 |
+-----+
Total Cost = 17
+-----+
| STATUS: UNWANTED HEADER FILE(S) |
+-----+
|          STRING.H          |
+-----+
+-----+
| COST ANALYSIS FOR WANTED HEADER FILES | Cost |
+-----+
|          STDIO.H          | 3 |
+-----+
Total Cost = 3
+-----+
+-----+
| Type is | Identifier | Cost |
+-----+
| Integer | i,n,t1=0,t2=1,nextPerm; | 10 |
+-----+
Total Cost = 10
+-----+
| For Loop Analysis | Cost |
+-----+
| Loop Running | 1 |
+-----+
Total Cost = 1
+-----+
| While Loop Analysis | Cost |
+-----+
| Loop Running | 0 |
+-----+
Total Cost = 0
Final cost of the Program is = 31
```

Fig 6.2: Output for the Input Program

## VI. Future enhancements

The tool helps the user in understanding the programming techniques more efficiently. Procedural programming technique is not in use much. So for future enhancement I will be concentrating on Object Oriented Programming. Dynamic addressing and pointers will also be considered in the analysis tools. Just finding the weights is not enough for the user so in future suggestion will be made by the tool to make the program more efficient and optimized which will help the user to understand more accurately about programming.

## VII. Acknowledgment

We thank our colleagues from SRM Institute of Science and Technology, Vadapalani who provided insight and expertise that greatly assisted the research, although they may not agree with all of the interpretations of this paper.

We thank Mrs. S Rama, Assistant Professor, SRMIST for assistance with CEAT Algorithm and System Architecture, and [Name Surname, position, institution name] for comments that greatly improved the manuscript.

We would also like to show our gratitude to the (Name Surname, title, institution) for sharing their pearls of wisdom with us during the course of this research, and we thank 3 "anonymous" reviewers for their so-called insights. We are also immensely grateful to (List names and positions) for their comments on an earlier version of the manuscript, although any errors are our own and should not tarnish the reputations of these esteemed persons.

### **References**

1. Davis and R.K. LeBlanc, A study of the applicability of complexity measures of programming, IEEE 'Pmns. So &are Engineering 14, 1366 -1372, (1988).
2. K.B. Lakshmanan, S. Jayaprakash and P.K. Sinha, Properties of control-flow complexity measures, IEEE 7hns. Software Engineering 17, 1289-1295, (1991).
3. J. Tian and M.V. Zelkowitz, Complexity measure evaluation and selection, IEEE hns. Sojtvjare Engineering 21, 641-650, (1995).
4. T. Menzies, D. Port, Z. Chen, J. K. Hihn and S. Stukes, "Validation Methods for calibrating software e\_ort models", ICSE '06: Proceedings of the 27<sup>th</sup> international conference of Software engineering, (New York, NY),,pp. 586-595, ACM Press,2005.
5. Boehm, B., Abts, C., Brown, A. W., Chulani, S., Clark, B.K., Horowitz, E., Madachy, R., Reifer, D. J., Steece, B. Software cost estimation with COCOMO II. Prentice-Hall, Upper Saddle River, NJ, February 2000.
6. IFPUG. Function Point Counting Practices Manual: Release 4.0. International Function Point Users Group, Princeton Junction, NJ, 1994.
7. Alaa g. sheta," Estimation and analysing of the COCOMO Model Parameters By Genetic Algorithm for NASA Software ", Journal of Computer Science, 2(2):128-124, 2006.
8. Ali Idri, alain Abran and Lailia Kijri, "COCOMO cost modeling using Fuzzy Logic", International conference on Fuzzy Theory and technology of Atlantic, 7 New Jersy, March 2001.
9. Baiely, j.w Basili, "A Meta model for Software Development Resource Expenditure", Proc. International. Conference of Software Engineering , pp : 107-115,1981

---

# Companion Chatbot

**Harsh Agrawal, Arup Patel, Aditya Bhosale, G.Paavai Anand**

<sup>1,2,3</sup>Student, Department of Computer Science and Technology, SRM Institute of Science and Technology, Vadapalani, Chennai, India

<sup>4</sup>Assistant Professor, Department of Computer Science and Technology, SRM Institute of Science and Technology, Vadapalani, Chennai, India

---

**ABSTRACT:** *Today, perception and expression of emotions are an important factor in the dialogue generation system. The project aims at generating a dialogue with specific emotions. To find the emotion categories, we apply the sentimental analysis on the dataset. We used the sequence-to-sequence neural network and done the modification for sentiment level correlation. Also, we take the advance of deep natural language processing and introduced sentiment rewards during the learning phase. For a better result of specific emotion and shorter training time compared to deep natural language processing, we try for the Hierarchical Recurrent Neural Network (HRNN). The embedding will be done with respect to a specific context. The experiment elaborates the accuracy not only in content but also in emotion.*

**Keywords:** *Hierarchical Recurrent Neural Network (HRNN), sentimental analysis, sequence-to-sequence model, deep natural language processing.*

---

## 1. Introduction

The ability to express and control our emotions is essential, but so is our ability to understand, interpret, and respond to the emotions of others (Mayer and Salovey 1997) [1]. Nowadays, a chatbot should be compatible not only in communication but it should also be able to perceive and express human emotions.

Existing models are capable of communication with specific emotions. But sometimes, they lack in preserving the context from the last query in which the user is communicating. The machine should also be aware of the context in which the user is communicating which minimizes the challenge of miscommunication in dialogue generation.

In this paper, we addressed the problem of the context with the communication in the neural network. Generally, the machine responds to human irrespective of any context and sometimes this may lead to wrong interpretation. So to avoid this problem, our machine will be trained using the Hierarchical Recurrent Neural Network (HRNN). In HRNN method, while the sentence has been encoded, the encoded value has been transferred and the decode point, and the context is saved as a temporal in the process which will be used in the next cycle of the process for another sentence. This will help the machine to preserve the context of communication between the user and the chatbot.

The proposed model may result better as compared to the current model but definitely, the complexity to the text content and emotion will be efficient using the context RNN.

## II. Problem Definition

### 2.1 Problem

Aim of the project is to create a chatbot who can act as a friend or companion to the user. The chatbot will help people who have difficulty in making friends or who have no friends. It can also cheer people, if they are sad and support them accordingly. The chatbot should support the user emotionally like a real friend does using end-to-end memory networks [2].

### 2.2 Dataset

The model was trained on the Twitter conversational data.

### 2.3 Evaluation

The performance of the system is evaluated on the phrase content and the emotion category. For the phrase content, we evaluate the system based on the generated outcome and expected outcome. The machine is not limited with the vocabulary, it learns over the time. The last one is the emotion category, based on the prediction of the emotion class for the previous phrase, performance of the system will be evaluated for the hypothetical phrases.

### III. Related Work

In natural language processing field, sentiment analysis is the most preferred part of research. Many practical application uses sentiment analysis method. In sentiment analysis, the two key problem is the emotion detection method and the response based on the emotion [5]. The two key problem in the system generates the high complexity in the interaction which may lead to the bad performance of the machine. In our module, the main focus is on both the key problem emotion generation method and the response generation.

In the present time, chatbot are a significant assistant to the application. Given the user input to the machine, it will analyze it and generate the response. In recent years, most of the models are based on the sequence-to-sequence (SEQ2SEQ) neural network architecture [4]. The advantage of sequence-to-sequence architecture is, it helps to process a long phrases of input and maintain a rich informational content between the user and chatbot.

Basically, a sequence-to-sequence model is having two recurrent neural network (RNNs): one is encoder and another one is decoder. Encoder used to process the input of the query from the user and decoder generates the relevant output of the query. Decode is having direct access of the word embedding with the encoder processed content to generate the most relevant output.

The objective function of SEQ2SEQ model is maximum-likelihood estimation (MLE). So this modules, may ignore the input and generate the generic response which may be frustrating for the user. For example, if user has given the input "How's your day?", so the response may be generic like "I am working".

To overcome this problem we have used hierarchical neural network (HRNN). The advantage of HRNN is, it is reward based method, which assigns some weight to the content which is nearly perfect to the input and improve the model through the advantage of context-aware part.

### IV. Methodology

This section includes an introduction to the topics relevant to this project.

#### 4.1 Sentiment Analysis

Sentiment Analysis [5] is a classification method that processes a text or message and obtains the sentiment associated with the text. In general, it is the process of determining the emotion from a sequence of words. Sentiment Analysis can be implemented by either the lexicon-based method or deep-learning method. In the lexicon-based method, a list of positive and negative words with an associated rank is used, all the known words are searched and their rank are combined. This method only provides negative or positive as output. In the deep-learning method, end-to-end models are used which require a large manually annotated dataset and its output not limited as the lexicon-based model. The deep learning model is superior but requires a large dataset. Tools like TextBlob and DeepMoji can be used for sentiment analysis on the dataset.

#### 4.2 Word Embedding

Word embedding [7] can be defined as vectors representation of particular words as shown in Fig.1. These are a class of techniques which is used to represent individual words as a vector in a predefined vector space. Words having similar meaning have similar representation or occupy adjacent space. Algorithms like Word2Vec, Glove, etc are used for learning word embedding. For example, words like good, well, nice, etc. will occupy adjacent space in a predefined vector space.

#### 4.3 Gated Recurrent Unit

GRU or Gated Recurrent Unit [2] is a variation of RNN which uses gating mechanism. It was introduced by Cho, et al. in 2014. It solves the problem of vanishing gradient and can retain information from the distant past. GRU uses two gates, an update gate( $Z_t$ ) and a reset gate( $R_t$ ) according to the equation (4.3.1). These gates decide what information should be passed to the next step. The update gate determines the amount of information, from previous steps, that are to be passed along the next steps. GRU is pictured in Fig.2.

$$Z_t = \sigma(W^{(z)}x_t + U^{(z)}h_{(t-1)}) \quad (4.3.1)$$

The reset gate decides the amount of information to forget or reset from previous steps, as given in the equation (4.3.2).

$$R_t = \sigma(W^{(r)}x_t + U^{(r)}h_{(t-1)}) \quad (4.3.2)$$

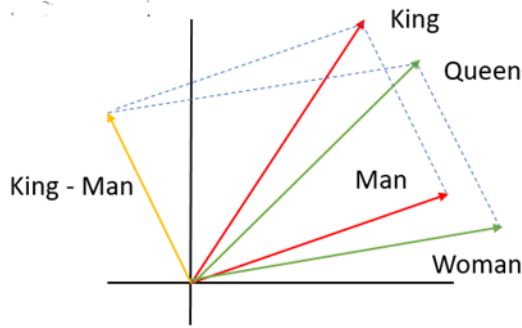

Fig.1 Word Vector Space

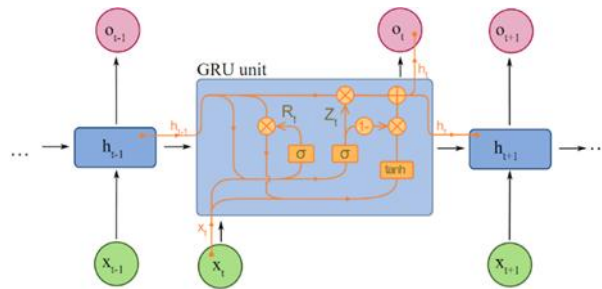

Fig.2 GRU Architecture

**4.4 Recurrent Neural Network**

In

recurrent neural network [3], for every single word  $v_n$ , there is a dense vector called the recurrent state  $l_n$ , that combines  $v_n$  with  $l_{n-1}$ , where  $l_{n-1}$  is the processed recurrent state. Eventually, as given in the equation (4.4),

$$l_0 = f(l_{n-1}, v_n), l_0 = 0 \tag{4.4}$$

where,  $l_n \in R_{d_h}$ ,  $d_h$  is the number of dimensions of recurrent state,  $f$  is the non-linear transformation and the recurrence is seeded with the 0 vector. The recurrent state  $h_n$ , is seen as the compact summary for the words seen till  $n^{\text{th}}$  position.

**4.5. Hierarchical Recurrent Encoder-Decoder**

The hierarchical recurrent encoder-decoder (HRED) [3] is pictured in Fig- 3. Query is passed to the encoder, which encodes the information available up to that position, and tries to predict the next possible query. The same process is repeated till all queries are processed. In the forward pass of HRED, model computes query encodings, the session level recurrent states and the log-likelihood of all query. In the backward pass, the gradient and parameter will be updated.

**4.5.1 Encoder**

For each query  $K_m = \{v_{p,1}, \dots, v_{p,D_p}\}$  in the training session  $S$ , the query level reads the words of the query sequentially and updates its hidden state according to equation (4.5.1):

$$h_{p,q} = GRU_{enc}(h_{p,q-1}, W_{p,q}), q = 1, \dots, D_p \tag{4.5.1}$$

**4.5.2 Decoder**

The RNN decoder predicts the next query  $Q_m$  based on the previous queries  $Q_{1:m-1}$ , i.e., to find the probability given in equation (4.5.2):



$$P(Q_m | Q_{1:m-1}) = \prod_{n=1}^{N_m} P(w_n | w_{1:n-1}, Q_{1:m-1}) \quad (4.5.2)$$

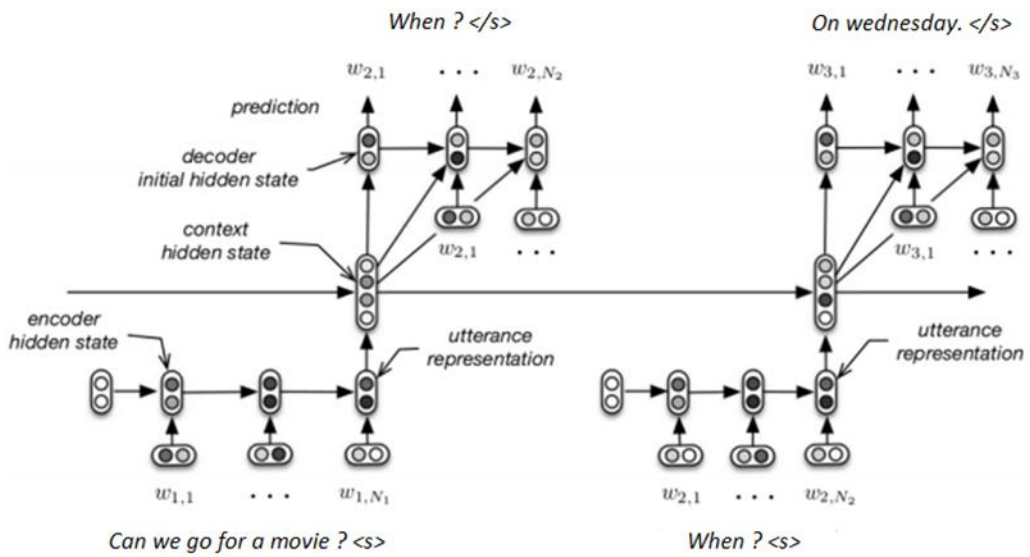

Fig. 5 HRED Architecture

**V. Proposed System**

Our proposed module elaborates about the conversation process between the human and the chatbot as pictured in Fig.4. The goal of our module is to help an introvert person to talk fearlessly in the public, community, and in the society. Our module also describes the dynamic emotion detection based on the query and also maintain the context of the conversation using the hierarchical recurrent encoder-decoder (HRED).

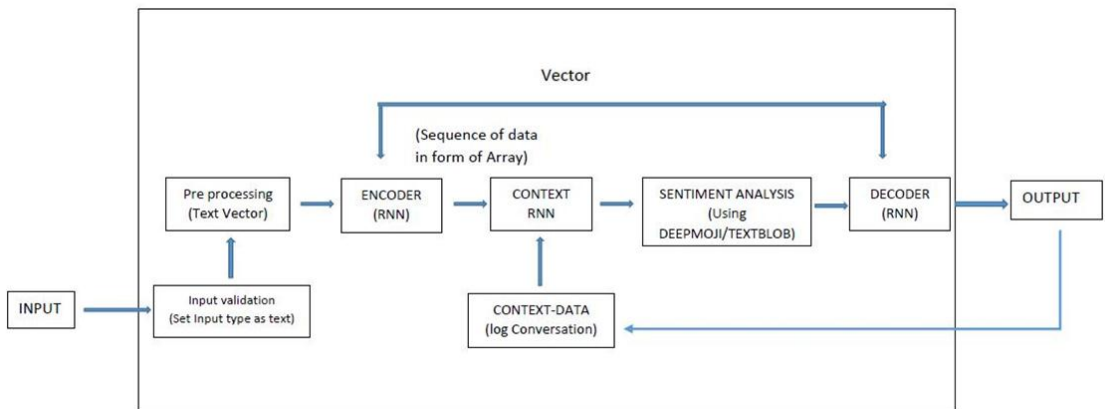

Fig.4 Architecture Diagram

Our model is trained on the Twitter conversational data that contains the user query with the expected output. In the interactive environment, user can chat with the bot. Since our module is not rule based, so the generated dialogue will be a context specific and give proper response.

Proposed system uses context-recurrent neural network model. This is a recurrent neural network model which has a long short term memory advantage to avoid long term dependency problem.

As the module starts working with user, each time user sends a query to the machine the machine starts preprocessing the query in form of words and store it as an utterance. The context RNN encodes the temporal structure of the utterance appearing in the dialogue, which allows information and gradient to flow

for a longer time span. The sentiment analysis works at the point of decoder to fetch the emotion of the sentence. At last the reply from bot with the emotion is displayed in an interactive environment.

**VI. Experimental Results**

In this section, we are going to discuss the results of our proposed system. The model is trained with a maximum encoded sequence of 30 tokens and a maximum decoder sequence of 32 tokens. The model was trained on a dataset of Twitter conversations. The data was cleaned by removing hashtags, URLs, etc. The data were filtered so that it does not exceed 30 tokens.

Then, the data were marked with DeepMoji emotion classifier. The emotion taken into consideration are neutral, happy, sad, anger and fear as mention in the Table 6.1. The system got a training accuracy of 82.29 per cent approx. and validation accuracy of 80.11 per cent approx. When compared to a vanilla SEQ2SEQ model[9], our model has better performance and better context persistence in conversation than a vanilla SEQ2SEQ model.

We used perplexity to evaluate proposed mode to the existing model. The results are shown in Table 6.2. Perplexity is used to measure the prediction error. The higher the value of perplexity the higher the percent of prediction error, whereas, the lower the value perplexity, lower will the prediction error. Perplexity can be calculated as equation (6.1):

$$2^{M(p)} = 2^{-\sum x p(x) \log_2 p(x)} \tag{6.1}$$

Table 6.1: Replies for different emotion

Message	Emotion	Response
Today is my birthday.	Joy	Happy Birthday
	Anger	I'm so jealous
	Neutral	Happy birthday!!! :) I miss you so much!!
	Fear	I'm sorry for my late reply...
	Sad	Happy birthday!!! I wish it was a bad day :(

Table 6.2: Perplexity comparison between Vanilla Seq2Seq model and HRNN

Classifier	Vanilla Seq2Seq	HRNN
Perplexity	301.9	65.67

We compare the performance of the emotion detection method. The result is shown in Table 6.3. We used emotional accuracy, defined as the number of responses with correct sentiment category by total number of items in training set. We achieved a better accuracy for the dynamic emotion detection method, is due to that the internal memory is better for sentiment representation. Moreover, the emotion distribution of our dataset is not balanced. For example, it is more toward the neural exactly one third of samples are labelled as 'neutral'. Therefore, the trained emotion detection method with neutral emotion is comparatively better than Sad, Happy, and Angry.

Table 6.3: Emotion accuracy comparison between Emotion Detection Method

	Static Emotion Detection	Dynamic Emotion Detection
Emotion Accuracy	0.3010	0.5067

For the graphical interface of the system, a server has been set up and flask, a python micro framework, has been used for creating an API service. The API service can be used for communicating with bot through front-end technologies likes Web apps, Mobile app, etc. The API service uses JSON or JavaScript object notation to sending and receiving the data. The GUI is pictured in Fig.5.

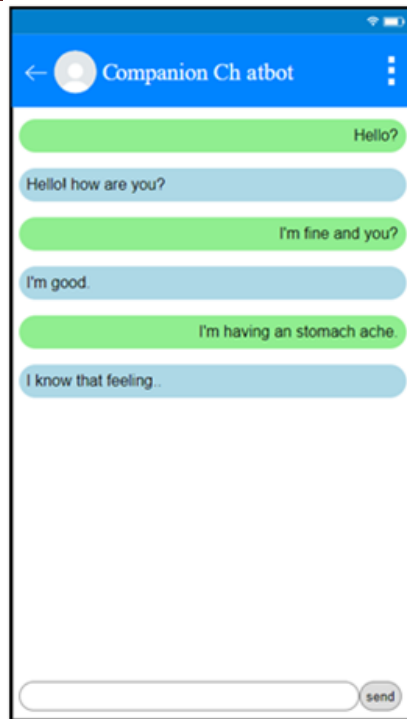

Fig. 5 Chatbot GUI

## VII. Conclusion and Future Work

In this article, we present a system that can communicate with a human like a friend and can maintain the context of the conversation. But it is still far from perfect. For future work, the model will be tweaked to generate responses faster and support for other languages along with SMS language will also be added.

## References

1. Hao Zhou, Minlie Huang, Tianyang Zhang, Xiaoyan Zhu and Bing Liu. Emotional Chatting Machine: Emotional Conversation Generation with Internal and External Memory. In Proceeding of Association for the Advancement of Artificial Intelligence 2018
2. Jincy Susan Thomas and Seena Thomas. Chatbot Using Gated End-to-End Memory Networks. In Proceeding of IRJET. March 2018
3. Alessandro Sordoni, Yoshua Bengio, Hossein Vahabi, Christina Lioma, Jakob G. Simonsen and Jian-Yun Nie. A Hierarchical Encoder-Decoder for Generative Context-Aware Query Suggestion. In Proceeding of 24<sup>th</sup> ACM International Conference on Information and Knowledge Management (CIMK 2015), Melbourne, Australia
4. Iulian V. Serban, Alessandro Sordoni, Yoshua Bengio, Aaron Courville and Joelle Pineau. Building End-to-End Dialogue Systems Using Generative Hierarchical Neural Network Models. In Proceeding of 13<sup>th</sup> AAAI Conference on Artificial Intelligence (AAAI-16), pages 3776-3783
5. Chae Won Park and Dae Ryong Seo. Sentiment Analysis of Twitter Corpus Related to Artificial Intelligence Assistants. In Proceeding of 5<sup>th</sup> International Conference on Industrial Engineering and Applications 2018, pages 495-498
6. Honghao WEI, Yiwei Zhao and Junjie Ke. Building Chatbot with Emotions.
7. Siwei Lai, Kang Liu, Shizhu He and Jun Zhao. How to Generate a Good Word Embedding. In Proceeding of IEEE Intelligent Systems, 2016
8. Bjarke Felbo, Alen Mislope, Anders Sogaard, Iyad Rahwan and Sune Lehmann. Using millions of emoji occurrences to learn any domain representation for detecting sentiment emotion and sarcasm. MIT (07 Oct 2017)
9. Ilya Suts Kever, Oriol Vinyals and Quoc V. Le. Sequence to Sequence Learning with Neural Network. Google Scholar (14 Dec 2014)