

Internet Communications Module

7845i

Installation and Setup Guide

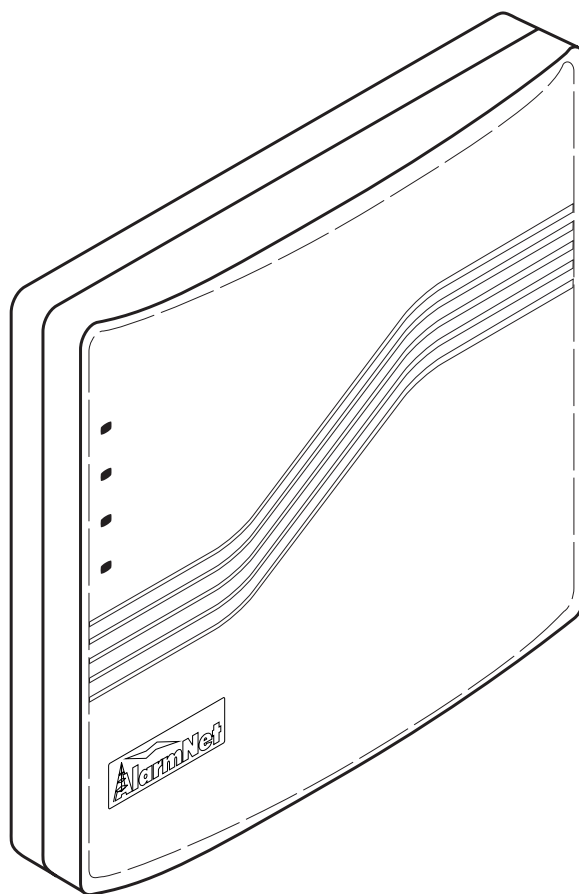

K0724 5/02

Table of Contents

<u>Section 1 General Information</u>	1-1
About AlarmNet-I	1-1
About 7845i	1-1
System Features	1-1
<u>Section 2 Mounting and Wiring</u>	2-1
Mounting 7845i	2-1
Wiring 7845i	2-2
<u>Section 3 Communications Setup</u>	3-1
General Information	3-1
Network Architecture	3-1
7845i Connectivity	3-1
Typical Residential Broadband Network Methods	3-1
Cable Modem Technology Primer	3-1
ADSL (Asynchronous Digital Subscriber Line) Primer	3-2
<u>Section 4 Programming AlarmNet-i Using 7720P</u>	4-1
General Information	4-1
Default Parameters	4-1
Using a 7720P Programming Tool	4-3
Programming the 7845i	4-4
AlarmNet-i Menu	4-5
General Account Information (Questions 1-2)	4-5
Primary Account Information (Questions 3-5)	4-5
Secondary Account Information (Questions 6-9)	4-5
System Options (Questions 10-12)	4-5
Reviewing AlarmNet-i Programming Entries	4-7
Getting to the Remote Access Menu from the AlarmNet-i Menu	4-8
Remote Access Menu	4-8
General AUI Information (Questions 1-2)	4-8
Master Account Information (Questions 3-5)	4-8
IP Address Information (Questions 6-10)	4-8
General Options (Questions 11-12)	4-9
Reviewing Remote Access Programming Entries	4-9
Getting to the AlarmNet-i Menu from the Remote Access Menu	4-9
Setting Factory Defaults	4-9
Exiting Programming Mode	4-9
ECP Status Codes	4-10
<u>Section 5 Registration</u>	5-1
Registering the 7845i	5-1
Interactive Registration	5-2
<u>Section 6 Summary of 7845i LED Operation</u>	6-1
7845i Status Display Operation	6-1
Status Display During Initial Power-up Sequence	6-2
Message Status During Normal (Idle) State	6-3
Message Status During Software Downloading	6-4
Status Display Operation When Software Download Fails	6-4
Network Connectivity Display	6-5
<u>Section 7 Programmer Keyboard Commands</u>	7-1
<u>Section 8 Getting Code Updates</u>	8-1
Updating the Code in the 7845i	8-1
<u>Section 9 Specifications</u>	9-1
Specifications	9-1
<u>Section 10 Glossary</u>	10-1
Glossary	10-1

General Information

In This Section

- ◆ *About AlarmNet-i*
- ◆ *About 7845i*
- ◆ *System Features*

About AlarmNet-i

AlarmNet-i is a fully encrypted; secure method of delivering alarm messages from a protected premise to an AlarmNet-i equipped central station. In a typical system, a 7845i Internet Communication Module or 8132 Advanced User Interface, routes status, supervisory, and alarm messages to the AlarmNet Control Center using a broadband Internet connection. AlarmNet Control identifies, validates and forwards the messages to the appropriate 7810iR Central Station Receiver. AlarmNet-i is implemented using TCP Internet protocol and 1024-bit encryption.

About 7845i

7845i is the subscriber end of the AlarmNet-i reporting system. It is comparable to a digital communicator or long-range radio, but instead of transmitting signals over telephone lines or radio waves, it transmits alarm and status messages to the central monitoring station using a secure broadband Internet connection.

Using the ECP keypad bus, the 7845i sends status messages such as tamper and network communication failures to the control panel. ECP also provides Contact ID for messages being sent to the central station.

System Features

- Report fire, burg, and status messages
- Security system operation via Symphony remote access
 1. Arm System
 - Away
 - Stay
 - Night
 2. Disarm System
 3. User Codes - Allows authorized user to add or delete codes

4. Bypass Zones - When system is not ready to arm, displays any open zones with:
 - Zone number
 - Zone description
 - Status
 - Bypass option
 5. Diagnostics
 6. Keypad Emulation
- Control of the home environment, including the heating and air-conditioning system, lights, garage door, etc. via Symphony remote interface.
 - Programmable using 7720P Programming tool.

Mounting and Wiring

In This Section

◆ *Mounting 7845i*

◆ *Wiring 7845i*

Mounting 7845i

7845i must be mounted **indoors**. To mount 7845i, see Figure 1 and complete the following steps:

1. Detach the case back by pushing up into the two tabs located at the bottom of 7845i with the blade of a screwdriver while pulling the case back and case front apart.
2. Locate the case back over the mounting surface such that the opening in the case back is aligned with the wire/cable access opening (in the mounting surface) while passing the wires/cable through the opening in the case back.
3. Secure the case back to the mounting surface using four screws (supplied).



Prior to attaching the case front to the case back, be sure to wire the 7845i as described in the "Wiring 7845i" paragraph in this section.

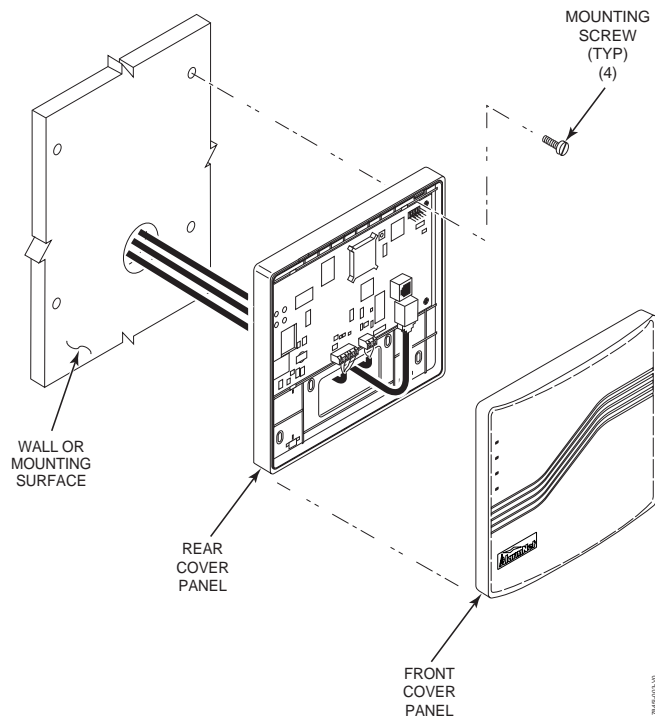

Figure 1. Mounting 7845i

Wiring 7845i

Connect 7845i in parallel with Keypads and other peripheral devices using the Keypad data (ECP) bus. To wire, see the Summary of Connections diagram at the rear of this guide and do the following.



Unshielded, 22 AWG cable is recommended for 7845i power/data wires.

Connect the wires to the header as follows:

1. Connect the Data Out terminal (pin 9) of the control panel to the Data In terminal of 7845i (yellow wire).
 2. Connect the Data In terminal (pin 8) of the control panel to the Data Out terminal of 7845i (green wire).
 3. Connect the AUX + terminal (pin 6) of the control panel to the +12VDC terminal of 7845i (red wire).
 4. Connect the AUX – terminal (pin 7) to the GND terminal of 7845i (black wire).
 5. Connect one end of the Ethernet cable (Category 5) to 7845i's RJ45 Ethernet connector and the other end to cable/DSL router.
-

UL

Use a Listed cable/DSL router suited for the application.

6. Attach the case front of 7845i to the case back. Attach the top of 7845i first, then press the bottom section inward until it snaps into place securely.

Communications Setup

In This Section

- ◆ *General Information*
- ◆ *Network Architecture*
- ◆ *7845i Connectivity*
- ◆ *Typical Residential Broadband Network Methods*
- ◆ *Cable Modem Technology Primer*
- ◆ *ADSL (Asynchronous Digital Subscriber Line) Primer*

General Information

This section provides an overview of networking techniques and methods commonly used in home and commercial Local Area Networks (LANs). While no single method described here may apply to your specific 7845i installation, the information should serve as a framework for increasing your general understanding of data network applications.

Network Architecture

This overview describes several typical LAN configurations:

- Cable Modem (DOCSIS)
- ADSL (Advanced Digital Subscriber Line)
- Dial on Demand Router

7845i Connectivity

The 7845i connects to any of these network variants in the same manner; via an Ethernet cable (10BaseT), terminating in an RJ45 connector. Although 7845i provides its own security and does not require a firewall, it is recommended that in most installations, 7845i be connected through a Firewall/Router device, which will enable the device to be connected to the home network without altering the connections of any other device on the network.

Typical Residential Broadband Network Methods

There are two typical “broadband” (high data rate) networking solutions available to the U.S. residential market: Cable Modem and ADSL. Currently, Cable Modem technology has the largest number of residential subscribers, since ADSL has certain range limitations that do not affect fiberoptic/coaxial cable networks. This section provides some background information on the technologies themselves.

Cable Modem Technology Primer

Cable systems were originally designed to deliver broadcast television signals efficiently to subscribers' homes. To ensure that consumers could obtain cable service with the same TV sets they use to receive over-the-air broadcast TV signals, cable operators recreate a portion of the over-the-air radio frequency (RF) spectrum within a sealed coaxial cable line.

Traditional coaxial cable systems typically operate with 330 MHz or 450 MHz of capacity, whereas modern hybrid fiber/coax (HFC) systems are expanded to 750 MHz or more.

Logically, downstream video programming signals begin around 50 MHz, the equivalent of channel 2 for over-the-air television signals. The 5 MHz - 42 MHz portion of the spectrum is usually reserved for upstream communications from subscribers' homes.

Each standard television channel occupies 6 MHz of RF spectrum. Thus a traditional cable system with 400 MHz of downstream bandwidth can carry the equivalent of 60 analog TV channels and a modern HFC system with 700 MHz of downstream bandwidth has the capacity for some 110 channels.

To deliver data services over a cable network, one television channel (in the 50 - 750 MHz range) is typically allocated for downstream traffic to homes and another channel (in the 5 - 42 MHz band) is used to carry upstream signals.

A headend cable modem termination system (CMTS) communicates through these channels with cable modems located in subscriber homes to create a virtual local area network (LAN) connection. Most cable modems are external devices that connect to a personal computer (PC) through a standard 10Base-T Ethernet card or Universal Serial Bus (USB) connection, although internal PCI modem cards are also available.

The cable modem access network operates at Layer 1 (physical) and Layer 2 (media access control/logical link control) of the Open System Interconnect (OSI) Reference Model. Thus, Layer 3 (network) protocols, such as IP traffic, can be seamlessly delivered over the cable modem platform to end users.

A single downstream 6 MHz television channel may support up to 27 Mbps of downstream data throughput from the cable headend using 64 QAM (quadrature amplitude modulation) transmission technology. Speeds can be boosted to 36 Mbps using 256 QAM. Upstream channels may deliver 500 kbps to 10 Mbps from homes using 16QAM or QPSK (quadrature phase shift key) modulation techniques, depending on the amount of spectrum allocated for service. This upstream and downstream bandwidth is shared by the active data subscribers connected to a given cable network segment, typically 500 to 2,000 homes on a modern HFC network.

An individual cable modem subscriber may experience access speeds from 500 kbps to 1.5 Mbps or more (depending on the network architecture and traffic load); blazing performance compared to dial-up alternatives. However, when surfing the Web, performance can be affected by Internet backbone congestion.

In addition to speed, cable modems offer another key benefit: constant connectivity. Because cable modems use connectionless technology, much like in an office LAN, a subscriber's PC is always online with the network. That means there's no need to dial-in to begin a session, so users do not have to worry about receiving busy signals. Additionally, going online does not tie up their telephone line, which is very important in an emergency reporting situation.

ADSL (Asynchronous Digital Subscriber Line) Primer

Asymmetric Digital Subscriber Line (ADSL) is a competing modem technology that converts existing twisted-pair telephone lines into access paths for multimedia and high-speed data communications. ADSL can transmit up to 6 Mbps to a subscriber, and as much as 832 kbps or more in both directions.

An ADSL circuit connects an ADSL modem on each end of a twisted-pair telephone line, creating three information channels -- a high-speed downstream channel, a medium speed duplex channel, depending on the implementation of the ADSL architecture, and a POTS (Plain Old Telephone Service) or an ISDN channel. The POTS/ISDN channel is split off from the digital modem by filters, thus guaranteeing uninterrupted POTS/ISDN, even if ADSL fails. The high-speed channel ranges from 1.5 to 6.1 Mbps, while duplex rates range from 16

to 832 kbps. Each channel can be sub-multiplexed to form multiple, lower rate channels, depending on the system.

ADSL modems provide data rates consistent with North American and European digital hierarchies and can be purchased with various speed ranges and capabilities. The minimum configuration provides 1.5 or 2.0 Mbps downstream and a 16-kbps duplex channel; others provide rates of 6.1 Mbps and 64 kbps duplex. Products with downstream rates up to 8 Mbps and duplex rates up to 640 kbps are available today. ADSL modems will accommodate ATM transport with variable rates and compensation for ATM overhead, as well as IP protocols.

Downstream data rates depend on a number of factors, including the length of the copper line, its wire gauge, presence of bridged taps, and cross-coupled interference. Line attenuation increases with line length and frequency, and decreases as wire diameter increases.

Programming AlarmNet-i Using 7720P

In This Section

- ◆ *General Information*
- ◆ *Default Parameters*
- ◆ *Using a 7720P Programming Tool*
- ◆ *7720P Keyboard Commands*
- ◆ *Programming the 7845i*
- ◆ *Reviewing AlarmNet-i Programming Entries*
- ◆ *Getting to the Remote Access Menu from the AlarmNet-i Menu*
- ◆ *Reviewing Remote Access Programming Entries*
- ◆ *Getting to the AlarmNet-i Menu from the Remote Access Menu*
- ◆ *Setting Factory Defaults*
- ◆ *Exiting Programming Mode*
- ◆ *ECP Status Codes*

General Information

There are two 7845i programming sections accessible from the 7720P Programming Tool: AlarmNet-i and Remote Access.

At a minimum, the 7845i must be programmed for AlarmNet-i to enable 1024 bit, encrypted alarm reporting to the central station via the Internet. Information such as AlarmNet account number (ID, City and CS) as well reporting options like Old Alarm Time and Supervision Time are entered. An AlarmNet account number is required to complete this.

Remote Access programming is used to activate Symphony home control features such as security system control, heating and cooling control and lighting control. Once enabled with the 7720P, Symphony home control features on the 7845i are accessed via the Internet using the same 1024 bit encryption to insure security. Remote Access must be programmed using a 7720P with a Symphony Master Account number prior to accessing a 7845i from a remote computer.

Default Parameters

A 7845i fresh out of the box has many parameters set to default values. These values for the AlarmNet-i features are listed in Table 1.

The default values for Remote Access Programming Features are listed below in Table 2.

Table 1. 7845i Programming Defaults Summary for AlarmNet-i Programming Features

	PROGRAMMING OPTION	STANDARD DEFAULT VALUE	ACTUAL ENTRY
1	En.AlarmNetI	Y	
2	Use Mstr Act	N	
3	Primary City ID	xx	
4	Primary CS ID	xx	
5	Primary Sub ID	xxxx	
6	En. 2nd CS Y/N	N	
7	ANI ECP Address	3	
8	Report Priority	Stand Alone	
9	Supervision	24 hours	
10	Old Alarm Time	10 minutes	
11	Flt Time (min)	5	

Table 2. 7845i Programming Defaults Summary for Remote Access Programming Features

	PROGRAMMING OPTION	STANDARD DEFAULT VALUE	ACTUAL ENTRY
1	En.Rem AccessY/N	N	
2	AUI ECP Address	1	
3	Master CS ID	xxxx	
4	Secondary CS ID	xxxx	
5	Subscriber ID	xxxx	
6	Use DHCP Y/N	Y	
7	RCP Serv Y/N	Y	
8	Lighting Y/N	N	

Using a 7720P Programming Tool

The 7845i powers the 7720P Programming Tool via the programming jack.

Each key of the 7720P has two possible functions: a normal function and a Shift function. To perform a normal key function, simply press the desired key. To perform a Shift function, press the [shift] key, and then press the appropriate key. For a description of each normal and shift key function, refer to Table 3.

Table 3. 7720P Normal and Shift Key (shift LED lit) Functions

KEY	NORMAL KEY FUNCTION	SHIFT KEY FUNCTION
BS/ESC	[BS]: Press to delete entry	[ESC]: Press to quit program mode; also can reset EEPROM defaults*
↓/↑	[↓]: Scroll down programming	[↑]: Scroll up programming
N/Y	[N]: Press for "NO" answer	[Y]: Press SHIFT-Y for "YES" answer
SHIFT	Press before pressing a SHIFT key function. Will light SHIFT LED. LED goes out once a key is pressed. Press again for each SHIFT function desired.	
1/A	[1]: For entering the number 1	[A]: For entering letter A
2/B	[2]: For entering the number 2	[B]: For entering letter B
3/C	[3]: For entering the number 3	[C]: For entering letter C
4/D	[4]: For entering the number 4	[D]: For entering letter D
5/E	[5]: For entering the number 5	[E]: For entering letter E
6/F	[6]: For entering the number 6	[F]: For entering letter F
7/S	[7]: For entering the number 7	[S]: For entering letter S
8/T	[8]: For entering the number 8	[T]: For entering letter T
9/X	[9]: For entering the number 9	[X]: For entering letter X
SPACE	[SPACE]: For scrolling option list	No SHIFT function
0	[0]: For entering the number 0	No SHIFT function
#/ENTER	[#/ENTER]: Press to accept entries	No SHIFT function

* Active only when the "REVIEW?" prompt is displayed.

Programming the 7845i

Provided that the initial power up sequence has completed and the 7720P cable is connected to the already powered the 7845i, you may proceed with programming the 7845i. Programming is accomplished by answering displayed questions. Most questions require only a [Y]es or [N]o response, while others require a numerical response (ID numbers, etc.). Press [ENTER] key to accept each response and proceed to the next question. The current value is displayed on the second line in parentheses (). A "?" indicates an invalid entry. To accept the current entry, press the [ENTER] key. If the current value is an invalid entry, pressing the [ENTER] key causes the display to repeat the unanswered question; the next question is not displayed until a valid answer is entered. Use the up/down arrow keys to scroll through the programming questions without changing any values. Press the [ESC] key to go to the end of the list of questions.

Enter programming mode by pressing [ENTER] AFTER the initial power-up sequence (refer to Section 6: Summary of 7845i LED Operation). To make sure that the user really meant to enter program mode, the following prompt appears:

```
Strt Prog Mode?  
Y/N _
```

Press [Y] if programming is desired, otherwise, press [N].

The user has the choice of two programming menus:

AlarmNet-i Programming OR
Remote Access Programming

These choices will be presented via the following prompts:

```
Program AlmNet?  
Y/N _  
Program Remote  
Access? Y/N _
```

If neither is chosen, the following prompt is displayed:

```
Exit Prog Mode?  
Y/N _
```

If [N] is pressed, the display will loop back up to the "Program AlmNet!" choice and the cycle is repeated until one of the prompts is answered with [Y].

Note that both menus can be accessed in one programming session.

AlarmNet-i Menu

General Account Information (Questions 1-2)

Question 1. Press [Y] to enable AlarmNet-i functionality.
Press [N] to disable AlarmNet-i functionality.

Question 2. Press [Y] to use the account information assigned to Remote Access (skip to question 6).
Press [N] to use AlarmNet-i specific account information

Primary Account Information (Questions 3-5)

Question 3. Enter the 2-digit primary city code, 01-99 (decimal).

Question 4. Enter the primary central station's system ID number, 01-FE.

Question 5. Enter the 4-digit customer account number, 0001-9999.

Secondary Account Information (Questions 6-9)

Question 6. Press [Y] if redundant reporting to a second central station is desired.
Press [N] if not desired (skip to question 10).

Question 7. Enter the 2-digit secondary city code, 01-99 (decimal).

Question 8. Enter the secondary central station's system ID number, 01-FE.

Question 9. Enter the secondary 4-digit customer account number, 0001-9999.

System Options (Questions 10-12)

Question 10. Enter the ECP device address on which the 7845i communicates with the panel as an AlarmNet-i (LRR) product. For VIA 30+, VISTA-10SE, and VISTA-20SE this must be address 3. For other control panels, see the control panel's Installation and Setup Guide.

UL

Dual reporting is required for UL installations. For example Internet with dialer backup.

Question 11.

Report Priority (Stand Alone)

 This selection sets the device priority for systems with multiple communication devices. If the system has no other communication device, then this option should be set to “Stand Alone” which is the default priority. For duplicate reporting, the priority should be set to “Secondary”. The secondary device is NOT responsible for the ECP communication (handshake) with the panel; it just reports the alarms that are sent to the primary device. If the primary device loses communication with the panel, then no alarms are sent by either device.

To toggle between the two choices, use the [space] and [backspace] keys

Press the [Enter] key to select the priority displayed.

Question 12

Supervision (24 Hours)

 This selection sets the supervision timing for 24 hour, 1 hour or 5 minutes. The default supervision timing is 24 hours. The 7845i sends a supervision message once during the supervision period. AlarmNet transmits a communications failure alarm to the central station if the supervision message is not received within the period.

To scroll through the available choices:

- Press the [space] key to scroll forward through the list of choices.
- Press the [backspace] key to scroll back through the list if the desired entry has scrolled past.

Press the [Enter] key to select the time displayed.

UL

Must be set to 5 minutes for UL installations.

Question 13.

Old Alarm Time (10 Minutes)

 The old alarm time sets how long an undeliverable alarm is retried for delivery to AlarmNet. If the message is not validated, it is retried until the old alarm time is reached or the message is validated. The choices available are: 10 Min., 15 Min., 30 Min., 1 Hr, 2Hr, 4Hr, 8Hr., 12Hr and 24Hr.

To scroll through the available choices:

- Press the [space] key to scroll forward through the list of choices.
- Press the [backspace] key to scroll back through the list if the desired entry has scrolled past.

Press the [Enter] key to select the time displayed.

UL

Old alarm time must be set to 10 minutes for UL installations.

Question 14.

Fit Time (min)

 Enter in minutes 1 - 99 the time delay before the 7845i notifies the control panel that there is loss of contact with the network. The 7845i will alert the control panel of the loss of contact with the network via the status message. Refer to Table 4 in this Section for more information regarding the ECP Status Codes.

UL

The time for 7845i to report lost communications to the Control Panel must be 1 minute for UL installations.

Reviewing AlarmNet-i Programming Entries

When the last question is answered the following is displayed:

Review AlarmNetI?

To review the AlarmNet-i programming options (to ensure that the correct responses have been made), press [Y]. The programming questions are displayed again, starting with Question 1 of this menu. Use the up/down arrow keys to scroll through the program fields without changing any of the values. If a value requires change, simply type in the correct value. When the last field is displayed, the “Review AlarmNetI?” question again appears.

Getting to the Remote Access Menu from the AlarmNet-i Menu

Once the AlarmNet-i programming menu has been completed and the answer to “Review AlarmNetI?” is [N]o, the following is displayed:

Remote Acc Prog?

The Remote Access Menu can now be viewed by pressing [Y]. If this is not desired, press [N] and the following is displayed:

Exit Prog Mode?
Y/N

As is the case at the entry of program mode, the menu choices and the option to exit program mode are repeated until one of the prompts is answered with [Y].

Remote Access Menu

UL

Remote access and lighting control have not been evaluated by UL.

General AUI Information (Questions 1-2)

Question 1.

En.Rem Access Y/N

Press [Y] to enable remote access through Symphony services.

Press [N] to disable remote access through Symphony services.

Question 2.

AUI ECP Address

Enter the ECP device address on which the 7845i will communicate with the control panel as an AUI.

Master Account Information (Questions 3-5)

Question 3.

Master CS ID

Enter the 4-digit Master Central Station ID.

Question 4.

Secondary CS ID

Enter the 4-digit Secondary Central Station ID.

Question 5.

Subscriber ID

Enter the 4-digit customer account number.

IP Address Information (Questions 6-10)

Question 6.

Use DHCP? Y/N

Press [Y] if it desired to have the IP addresses dynamically allocated (skip to question 11).

Press [N] if fixed IP addresses are desired.

Question 7.

NIC IP Address

Enter the 4-part IP address for this device. The 4 parts of the address must be separated by spaces.

Question 8.

Subnet Mask

Enter the 32-bit address mask used to indicate the portion (bits) of the IP address that is being used for the subnet address. The 4 parts of the address must be separated by spaces.

Question 9.

Gateway IP Addr

Enter the 4-part IP address assigned to the Gateway. The 4 parts of the address must be separated by spaces.

Question 10. Enter the 4-part IP address assigned to the DNS (Domain Name System) server. The 4 parts of the address must be separated by spaces.

General Options (Questions 11-12)

Question 11. Press [Y] to allow access to the Remote Control Proxy Protocol Service.

Press [N] if access to the Remote Control Proxy Protocol Service is not desired.

Question 12. Press [Y] to enable the Lighting Control buttons through remote access.

Press [N] to disable the Lighting Control buttons through remote access.

Reviewing Remote Access Programming Entries

When the last question is answered the following is displayed:

To review the Remote Access programming options (to ensure that the correct responses have been made), press [Y]. The programming questions are displayed again, starting with Question 1 of this menu. Use the up/down arrow keys to scroll through the program fields without changing any of the values. If a value requires change, simply type in the correct value. When the last field is displayed, the “Review Rem Acc?” question again appears.

Getting to the AlarmNet-i Menu from the Remote Access Menu

Once the Remote Access programming menu has been completed and the answer to “Review Rem Acc?” is [N]o, following is displayed:

The AlarmNet-i Menu can now be viewed by pressing [Y]. If this is not desired, press [N] and the following will be displayed:

As is the case at the entry of program mode, the menu choices and the option to exit program mode are repeated until one of the prompts is answered with [Y].

Setting Factory Defaults

Reset the programming options to factory-default values (as listed in Tables 1 and 2) by pressing [ESC] at the “Exit Prog Mode?” prompt. A confirmation prompt appears. Press [Y] to default the values, or press [N] to cancel this function. If you press [Y], all programmed values of both menus are reset to the original factory settings.

Exiting Programming Mode

To exit the programming mode, press [Y] in response to the “Exit Prog Mode?” question. Upon exiting, the root file is updated to log the changes made. A message is displayed telling the user that this step is being executed. When complete, the message “DONE” is displayed to indicate the programming session has ended. If critical configuration changes were made during programming, the 7845i will reset to ensure that the programmed features are enabled.

ECP Status Codes

The 7845i sends status messages to the control panel for tamper and network communication failures. When using ADEMCO's low-end control panels (VISTA-10SE, VISTA-20SE, VIA-30P, the status is displayed on the control panel's keypad as "Long Rnge Fail" followed by a 4-digit code). These codes are listed in Table 4, as well as Contact ID codes (listed in Table 5) that are sent to the central station.

Table 4. ECP Keypad Displays Status Codes

STATUS CODE	DESCRIPTION
0000	Control panel lost communication with 7845i
0880	7845i tamper detected (cover removed)
0005	7845i has lost contact with AlarmNet
000F	7845i is not registered; radio account not activated
0400	7845i Power On Reset.
0C80	7845i Power On Reset & Tamper detected
0C8F	7845i Power On Reset & Tamper detected & Not Registered

Table 5. ECP Contact ID (685 Displays) Codes

CODE*	DESCRIPTION
R330 C8xx**	Restore of RF faults (restore of peripheral trouble)
E339 C8xx**	ECP power-on reset
E341 C8xx**	ECP tamper
R341 C8xx**	ECP tamper restore
E355 C000	Radio lost communication with control panel
R355 C000	Radio restore communication with control panel

* As displayed on 685 Digital Receiver.

** xx = 7845i device address.

Registration

In This Section

- ◆ Registering the 7845i
- ◆ Interactive Registration

Registering the 7845i

Once you have initialized and programmed the 7845i, it must be registered with AlarmNet Control. An unregistered 7845i is indicated on the Status Display as: TX lit, Message Status blinking, and Fault not lit. The Internet Link may be lit or blinking. Refer to Section 6 for a detailed discussion of LED operation.

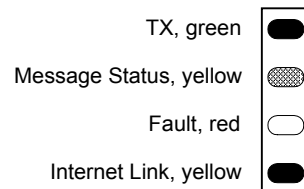

Figure 2. Unregistered 7845i Status Display In Normal Operation

Throughout this document, the following key is used to describe LED state:

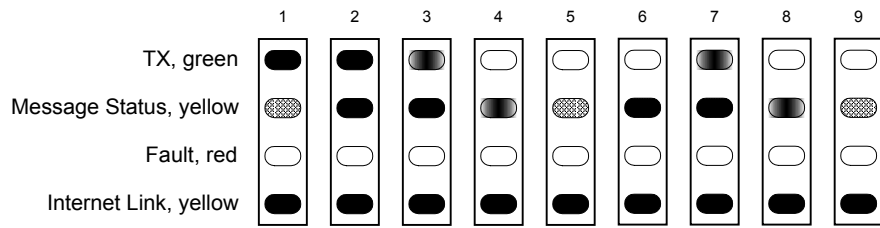

Figure 3. LED Key

To complete the registration process, a 7845i transmits a registration message and receives a registration validation from AlarmNet Control.

Initiate the registration sequence by either clicking the tamper switch three times or by pressing [shift] and the up arrow [↑] on the 7720P. If you are using a 7720P, skip to the "Interactive Registration" paragraph in this section.

You can monitor the registration process by viewing the Status Display. The Message Status (yellow) LED will go on solid indicating that the registration message is pending. The TX (green) LED will blink rapidly when the registration is accepted.



1. Unregistered, normal operation
2. Registration message pending
3. Registration message transmitted
4. Registration accepted by AlarmNet
5. Registered, normal operation
6. Power-on reset message pending
7. Power-on reset message transmitted
8. Power-on reset message acknowledged by AlarmNet
9. Normal operation

Once the registration has been completed successfully, the 7845i enters normal operating mode; the TX (green) LED goes out and the Message Status (yellow) LED is lit to indicate that the power-on / reset message is waiting to be sent. If registration is not validated within 30 seconds, the 7845i times out.

If repeated registration attempts time out, check your Internet connection and verify that 7845i account information has been entered correctly.

Interactive Registration

The interactive registration feature allows the installer to register the 7845i through a series of keyboard commands on the 7720P Programming Tool. This method of registration lets the installer monitor the registration process.

Registering ...

Once the installation is complete, press the [↑] key on the 7720P. The registration message is sent and the unit waits for the acknowledgment.

Registration SUCCESS

If this is a new installation and the city, central station, and customer numbers have been correctly entered, the 7845i is registered and this message is displayed. At this point, the 7845i is in full service and available for alarm reporting to the central station.

Possible Errors

Registration BAD Timed Out	If no response to the registration request is received from AlarmNet, this message is displayed.
Registration BAD Pri Sub ID BAD	The city, central station, or customer number for the Primary account is not accepted. The ID information was either entered in error, or the central station failed to pre-authorize programmed ID numbers with AlarmNet customer service.
Registration BAD 2nd Sub ID BAD	The city, central station, or customer number for the Secondary account is not accepted. The ID information was either entered in error, or the central station failed to pre-authorize programmed ID numbers with AlarmNet customer service.
Registration BAD Pri&2nd IDs BAD	The city, central station, or customer number for BOTH the Primary and Secondary accounts are not accepted. The ID information was either entered in error, or the central station failed to pre-authorize programmed ID numbers with AlarmNet customer service.
Registration BAD Pri ID – Need PIN	This prompt is displayed if this is a repair/replacement, or an error was made in programming the Primary account information of 7845i for an existing account. This prompt appears for two seconds. See the 7845i Replacement section below for further displays.
Registration BAD 2nd ID – Need PIN	This prompt is displayed if this is a repair/replacement, or an error was made in programming the Secondary account information of 7845i for an existing account. This prompt appears for two seconds. See the 7845i Replacement section below for further displays.
Registration BAD Pri&2nd – Need PIN	This prompt is displayed if this is a repair/replacement, or an error was made in programming the BOTH the Primary and Secondary account information of 7845i for an existing account. This prompt appears for two seconds. See the 7845i Replacement section below for further displays.

7845i Replacement

Enter PIN now? Y/N	At this point, you should have called call the AlarmNet Technical Assistance Center (TAC) to obtain a 4-digit alphanumeric PIN number. Pressing [Y] continues the registration process. If you pressed [Y] the next prompt is displayed. Pressing [N] aborts the process.
PIN:	You must enter a 4-digit alphanumeric PIN number obtained by an authorized person's phone call to the AlarmNet TAC (Technical Assistance Center). Enter the PIN, then press the [Enter] key.
Registering ...	The registration message is sent and the unit waits for acknowledgement.

Registration
SUCCESS

If the PIN is valid, the new 7845i is registered and the old unit unregistered. Additionally, AlarmNet sends a substitution alarm to the central station.

Registration BAD

If you entered an invalid PIN, the appropriate message is displayed depending on which account number is being replaced (see above for exact wording). The registration process is repeated.

NOTE: Each attempt causes a substitution alarm to be sent to the central station.

Summary of 7845i LED Operation

In This Section

- ◆ 7845i Status Display Operation
- ◆ Network Connectivity Display

7845i Status Display Operation

The 7845i Status display has four LEDs used to indicate message and device status:

- TRANSMIT, *green*
- MESSAGE STATUS AND HEARTBEAT, *yellow*
- FAULT, *red*
- INTERNET LINK, *yellow*

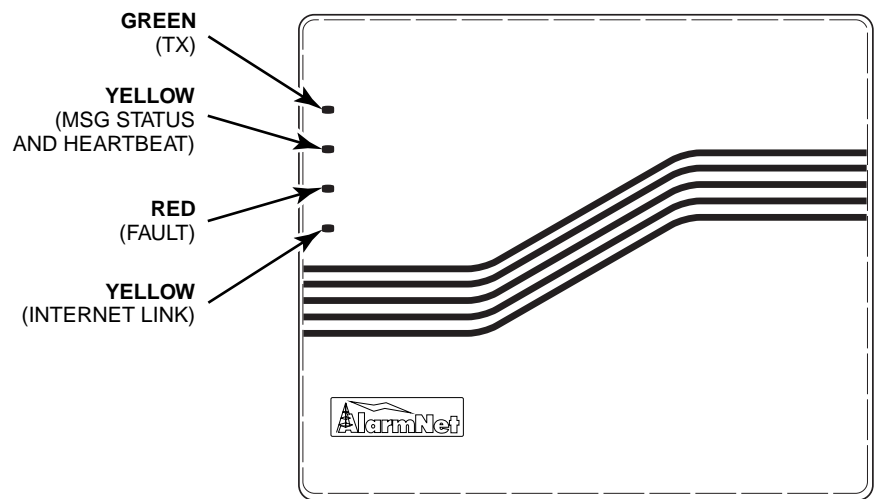

Figure 4. 7845i Status Display LEDs with Front Cover Installed

Each LED's on and off state has specific meaning during each of the four different modes of operation. The four state of operation are:

- Initial Power-up Sequence
- Normal (Idle) State
- Software Download State
- Software Download State - Failure Modes

Each LED can have four different states - ON, OFF, FAST BLINK and SLOW BLINK.

Throughout this document, the following key is used to describe LED state:



Figure 4. LED Key

Status Display During Initial Power-up Sequence

During the initial power-up sequence, the TX, MESSAGE STATUS and FAULT LEDs flash in succession to indicate three stages of startup. The INTERNET LINK LED flashes independently of the other three and may be in any state during initial power-up. At the end of the sequence, when the startup process completes, all of the LEDs (except the INTERNET LINK LED) remain lit for half of second. They then go out for half of a second before the 7845i enters normal (idle) state.

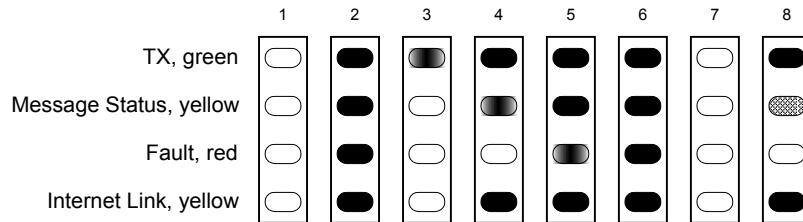

Figure 5. Status Display Sequence During Initial Power-up of an Un-registered 7845i

LED COLOR	LED	DESCRIPTION
GREEN	TRANSMIT	FAST BLINK – In the process of starting up the internal File System. ON – Completed startup of internal File System.
1 ST YELLOW	MESSAGE STATUS AND HEARTBEAT	FAST BLINK – In the process of starting the Network Maintenance System. ON – Completed startup of Network Maintenance System. OFF – At completion of this stage, the 7845i failed to get the Root File.
RED	FAULT	FAST BLINK – In the process of starting low-level drivers and message processing. If remote access to AUI functionality is enabled, the CAL application and network layers are started. Also, the panel configuration is checked and a panel exchange is executed. ON – Successfully completed the startup of the above listed functions. OFF – At the completion of this stage, the 7845i failed to complete the panel exchange because either the panel was not online or it was not communicating with the 7845i.
2 ND YELLOW	LINK	ON – Connected to internet. OFF – not connected. FAST BLINK – either sending or receiving data. SLOW BLINK – connecting to server.

Message Status During Normal (Idle) State

During Normal Operation the yellow Message Status LED function as the 7845i's heartbeat. With no message pending, the heartbeat is an indication that the unit is functioning.

The yellow Internet Link LED may be lit solidly or periodically blink during normal operation.



Figure 6. A Registered 7845i Status Display (A) and an Unregistered 7845i Status Display in Normal Operating State

The sequence below illustrates LED operation when 7845i transmits a message.

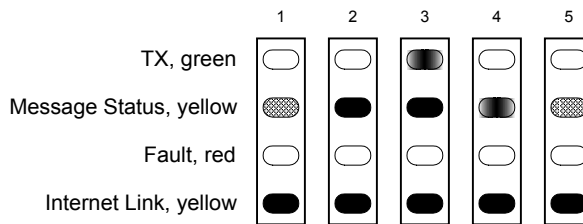

Figure 7. LED Sequence for a Registered 7845i Message Transmission

LED COLOR	LED LABEL	DESCRIPTION
GREEN	TRANSMIT	ON – 7845i is NOT registered with AlarmNet. FAST BLINK – Successful message transmission.
1 ST YELLOW	MESSAGE STATUS AND HEARTBEAT MESSAGE STATUS	ON – Message Pending. SLOW BLINK – Normal Operation, Heartbeat. FAST BLINK – Message has been acknowledged by network.
RED	FAULT	ON – No contact with the network. SLOW BLINK – Loss of communication with the panel (ECP fault). CONTINUOUS FAST BLINK – No contact with the network AND loss of communication with the panel. SHORT-TERM FAST BLINK – Registration attempt has been rejected.
2 ND YELLOW	INTERNET LINK	ON – Connected to Internet. OFF – Not connected. FAST BLINK – Either sending or receiving data. SLOW BLINK – Connecting to server.

Message Status During Software Downloading

LED COLOR	LED LABEL	DESCRIPTION
GREEN	TRANSMIT	ON – Obtained IP address (via either DHCP client or static IP assignment). OFF – Not connected. SLOW BLINK – Connecting to server.
1 ST YELLOW	MESSAGE STATUS AND HEARTBEAT MESSAGE STATUS	ON – Connected to server. FAST BLINK – Could not connect to server (no route or authentication failure). SLOW BLINK – Connecting to server.
RED	FAULT	ON – Successfully downloaded configuration data. FAST BLINK – Could not download configuration data or if with MESSAGE STATUS FAST BLINK then it connected to server but failed authentication.
2 ND YELLOW	INTERNET LINK	ON – Erasing application code. SLOW BLINK – Downloading application code. VERY SLOW BLINK – Verifying CRC after successful code download.

Status Display Operation When Software Download Fails

There are two sequences providing failure information in the event a software download fails:

1. CRC failure 1 (calculated CRC does not match CRC provided with binary)
 - TX, MESSAGE STATUS, FAULT and INTERNET LINK – all FAST BLINK for 3 seconds, following
 - TX, MESSAGE STATUS, FAULT and INTERNET LINK ON for 3 seconds and following
 - TX, MESSAGE STATUS, FAULT and INTERNET LINK FAST BLINK for 3 seconds.

2. CRC failure 2 (calculated network CRC does not match CRC provided with binary)
 - TX, MESSAGE STATUS, FAULT and INTERNET LINK – all FAST BLINK for 3 seconds, following
 - TX, MESSAGE STATUS, FAULT and INTERNET LINK SLOW BLINK for 3 seconds and following
 - WEB, MESSAGE STATUS, FAULT and INTERNET LINK FAST BLINK for 3 seconds.

Network Connectivity Display

The Network Connectivity display can only be viewed with the cover removed. It is used as a visual indication of 7845i network activity.

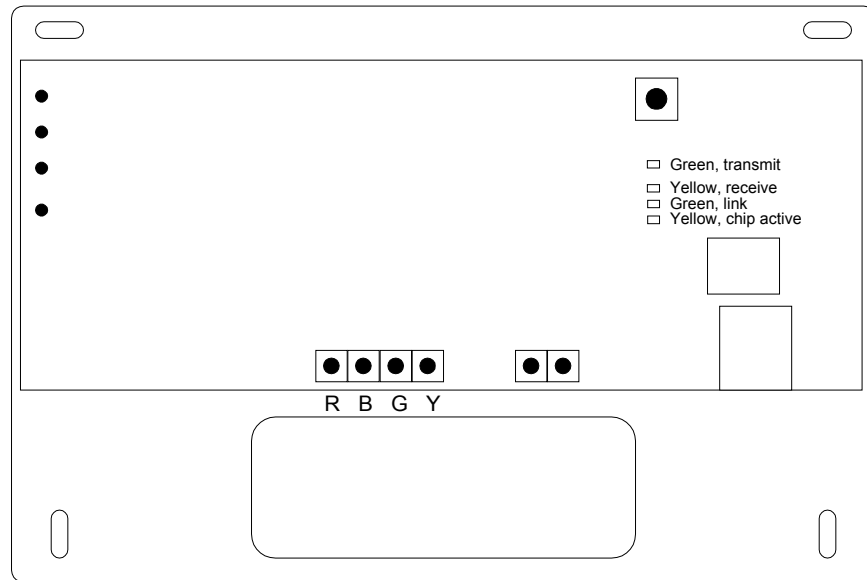

Figure 8. 7845i Network Connectivity Display

The Network Connectivity Display consists of four LEDs. They function as follows:

- Green, transmit, illuminates when 7845i is transmitting a message on the network.
- Yellow, receive, illuminates when 7845i is receiving a message from the network
- Green, link, illuminates when 7845i is physically connected to the network.
- Yellow, chip active, illuminates when the 7845i microprocessor is addressing the Ethernet controller.

Programmer Keyboard Commands

- [A]

Version:	x.x.xx
Date:	mm/dd/yy

Software Revision
 "x.x.xx" indicates the installed software Revision.
 mm/dd/yy indicates month, day and year of the revision.
- [B]

MAC Address:	xxxxxx-xxxxxx
--------------	---------------

MAC Address
 "xxxxxx-xxxxxx" indicates the 7845i's unique identification number.
- [C]

Preparing to Get Code ...

Get Code Command
 Updates the code running in the 7845i. Refer to *Section 8: Getting Code Updates*.
- [D]

Physical Link:	Yes
----------------	-----

Network Diagnostics Display
 Indicates whether device has detected a physical connection to the internet.
 Press the [space] key to get next field.
- | | |
|-----------------|-----|
| IP Assigned: | Yes |
| xxx.xxx.xxx.xxx | |

 Indicates whether this device has an IP address assigned to it. If not, "Yes" is replaced with "No".
 xxx.xxx.xxx.xxx is the IP address assigned to this device.
 Press the [backspace] key to get previous field.
- [E]

NIC IP Address:	xxx.xxx.xxx.xxx
-----------------	-----------------

IP Information Display
 Displays the IP address assigned to this device.
 Press the [space] key to get next field.
- | | |
|--------------|-----------------|
| Subnet Mask: | xxx.xxx.xxx.xxx |
|--------------|-----------------|

 Displays the 32-bit address mask used to indicate the portion (bits) of the IP Address that is being used for the subnet address.
 Press the [space] key to get next field.
 Press the [backspace] key to get previous field.
- | | |
|------------------|-----------------|
| Gateway IP Addr: | xxx.xxx.xxx.xxx |
|------------------|-----------------|

 Displays the IP Address assigned to the Gateway.
 Press the [space] key to get next field.
 Press the [backspace] key to get previous field.
- | | |
|-------------------|-----------------|
| DNS Serv IP Addr: | xxx.xxx.xxx.xxx |
|-------------------|-----------------|

 Displays the IP Address assigned to the DNS (Domain Name System) server.
 Press the [space] key to get NIC IP address.
 Press the [backspace] key to get previous field.
- [F]

Restrt Net Serv	Y/N _
-----------------	-------

Restart Network Services Command
 Press [Y] to re-establish IP addresses as well as connection to AlarmNet.
 Press [N] to return to normal mode.

[T]	Test Msg Sent	Test Alarm Sends a Test alarm to AlarmNet. Functional for a <i>registered</i> 7845i is only. If the device is not registered, a message is displayed indicating that the command cannot be executed.
[X]	Reset CPU Y/N	Reset the 7845i. Pressing [N] returns to normal mode. Pressing [Y] resets the device
[↑]	Registering ...	Registration Registers a programmed 7845i with AlarmNet. Refer to <i>Section 5: Registration</i> .

Getting Code Updates

Updating the Code in the 7845i

The code running in the 7845i can be updated with key command using the 7720P. Refer to Section 6 for a description of Status Display LEDs during code update.

Preparing to Get
Code ...

If new code is desired, press the [C] key on the 7720P. This initiates the “Get Code” algorithm.

Choose Directory
(Release)

If code is available in multiple directories, the user is presented with a list of directory names.

To scroll through the available choices:

- Press the [space] key to scroll forward through the list of choices.
- Press the [backspace] key to scroll back through the list if the desired entry has scrolled past.

Press the [Enter] key to select the directory displayed

Checking Config
File

The 7845i reads through the configuration file found in the directory chosen to determine if the code available meets the requirements of the 7845i.

Get Ver x.x.xx
Y/N _

The configuration information is acceptable. “x.x.xx” indicates the software version available.

Press [Y] to accept this version.

Press [N] to abort the code download.

Get P1 Loader?
Y/N _

The configuration information indicates that a higher version of the P1 Loader is available. **It is VERY RARE that a new version of the P1 System loader is needed.**

Press [Y] to download the P1 Loader before resetting the 7845i to initiate the code update.

Press [N] to just reset the 7845i to initiate the code update *without* downloading the P1 Loader.

Get P0 Loader?
Y/N _

The configuration information indicates that a higher version of the P0 Loader is available. **It is VERY RARE that a new version of the P0 System loader is needed.**

Press [Y] to download the P0 Loader before resetting the 7845i to initiate the code update.

Press [N] to just reset the 7845i to initiate the code update *without* downloading the P0 Loader.

Possible Errors

Valid File NOT
Found

The configuration information found in the directory specified did not meet the requirements of the 7845i. At this point the user can re-initiate the Get Code Command and choose a different directory for the code update.

Config File
Download FAILURE

The configuration information could not be found. The code update cannot be performed at this time.

Pnl S/W Mismatch
Continue?

The configuration information indicates that a higher version of panel software is required. If the code update is pursued, some features may not work correctly.

Press [Y] to continue with code update.

Press [N] to abort the update using this directory.

The user can re-initiate the Get Code Command and choose a different directory for the code update.

Specifications

.....

Specifications

MECHANICAL	
Dimensions:	
Width:	7.5 inches
Height:	6.5 inches
Depth:	1.5 inches
ELECTRICAL	
Operating Voltage:	10-14V
Current Drain:	110-80 mA

Glossary



Glossary

DHCP (Dynamic Host Configuration Protocol). Provides a mechanism for allocating IP addresses dynamically so that addresses can be reused when hosts no longer need them.

DNS (Domain Name System). A distributed hierarchical naming system used to resolve domain names (e.g., www.yahoo.com) into numerical IP addresses (e.g., 204.17.25.1).

DSL - Digital Subscriber Line

Gateway IP Address - A gateway (sometimes called a router) is a computer and/or software used to connect two or more networks (including incompatible networks) and translates information from one network to the other. The Gateway IP address is the IP address for the gateway.

IP - Internet Protocol

IP Address - A unique number consisting of 4 parts separated by periods, sometimes called a "dotted quad.," for example: 204.17.29.11, assigned to every computer/workstation connected to the Internet. IP numbers can be "static" (assigned and unchanging) or "dynamic," assigned via DHCP at each and every startup.

ISP - Internet Service Provider

LAN - Local Area Network

MAC Address -The hardware address of a device connected to a network.

NAT - Network Address Translation

PPP - Point-to-Point Protocol

PPPoE - Point-to-Point Protocol over Ethernet

RCPP - Remote Control Proxy Protocol

Subnet Mask - A Subnet is a portion of a network that shares a network address with other portions of the network, and is distinguished by a subnet number. The Subnet Mask is a 32-bit address mask used in IP to indicate the bits of an IP address that are being used for the subnet address.

TCP/IP - Transmission Control Protocol / packet-based protocol

UDP - User Datagram Protocol

WAN - Wide Area Network

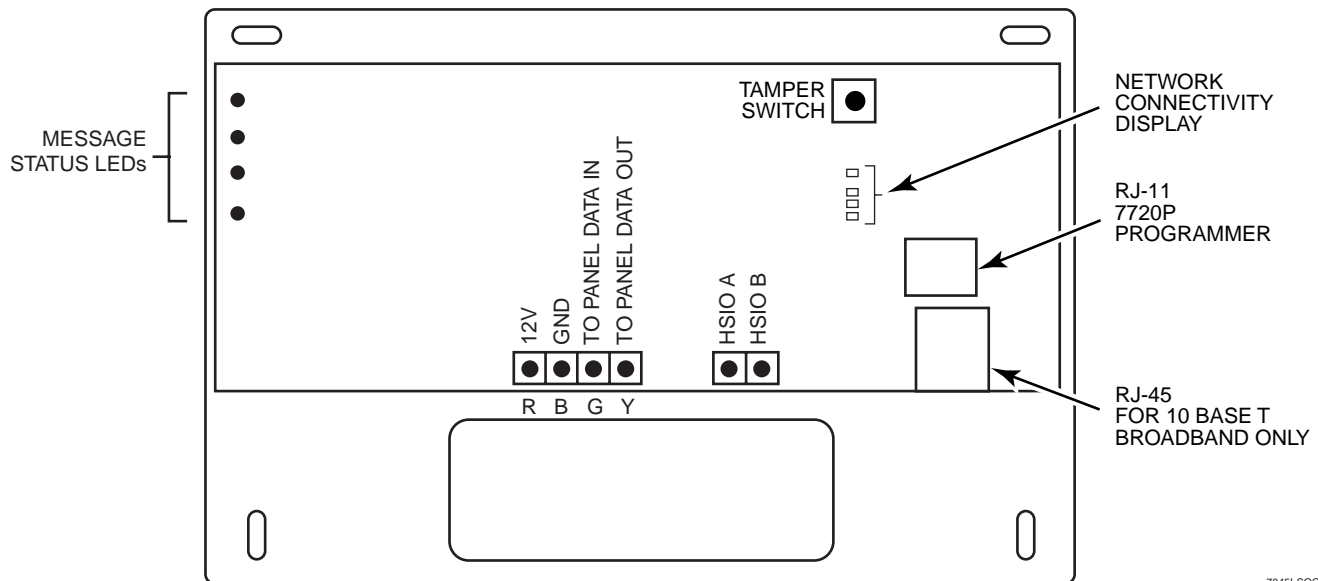

7845I-SOC-V0

ADEMCO LIMITED WARRANTY

Alarm Device Manufacturing Company, a Division of Pittway Corporation, and its divisions, subsidiaries, and affiliates ("Seller"), 165 Eileen Way, Syosset, New York 11791, warrants its products to be in conformance with its own plans and specifications and to be free from defects in materials and workmanship under normal use and service for 24 months from the date stamp control on the product or, for products not having an ADEMCO date stamp, for 12 months from date of original purchase unless the installation instructions or catalog sets forth a shorter period, in which case the shorter period shall apply. Seller's obligation shall be limited to repairing or replacing, at its option, free of charge for materials or labor, any product which is proved not in compliance with Seller's specifications or proves defective in materials or workmanship under normal use and service. Seller shall have no obligation under this Limited Warranty or otherwise if the product is altered or improperly repaired or serviced by anyone other than ADEMCO factory service. For warranty service, return product, transportation prepaid, to your nearest ADEMCO distributor.

THERE ARE NO WARRANTIES, EXPRESS OR IMPLIED, OF MERCHANTABILITY, OR FITNESS FOR A PARTICULAR PURPOSE OR OTHERWISE, WHICH EXTEND BEYOND THE DESCRIPTION ON THE FACE HEREOF. IN NO CASE SHALL SELLER BE LIABLE TO ANYONE FOR ANY CONSEQUENTIAL OR INCIDENTAL DAMAGES FOR BREACH OF THIS OR ANY OTHER WARRANTY, EXPRESS OR IMPLIED, OR UPON ANY OTHER BASIS OF LIABILITY WHATSOEVER, EVEN IF THE LOSS OR DAMAGE IS CAUSED BY THE SELLER'S OWN NEGLIGENCE OR FAULT.

Seller does not represent that the products it sells may not be compromised or circumvented; that the products will prevent any personal injury or property loss by burglary, robbery, fire, or otherwise; or that the products will in all cases provide adequate warning or protection. Customer understands that a properly installed and maintained alarm may only reduce the risk of a burglary, robbery, fire, or other events occurring without providing an alarm, but it is not insurance or a guarantee that such will not occur or that there will be no personal injury or property loss as a result. CONSEQUENTLY, SELLER SHALL HAVE NO LIABILITY FOR ANY PERSONAL INJURY, PROPERTY DAMAGE, OR OTHER LOSS BASED ON A CLAIM THE PRODUCT FAILED TO GIVE WARNING. HOWEVER, IF SELLER IS HELD LIABLE, WHETHER DIRECTLY OR INDIRECTLY, FOR ANY LOSS OR DAMAGE ARISING UNDER THIS LIMITED WARRANTY OR OTHERWISE, REGARDLESS OF CAUSE OR ORIGIN, SELLER'S MAXIMUM LIABILITY SHALL NOT IN ANY CASE EXCEED THE PURCHASE PRICE OF THE PRODUCT, WHICH SHALL BE THE COMPLETE AND EXCLUSIVE REMEDY AGAINST SELLER. This warranty replaces any previous warranties and is the only warranty made by Seller on this product. No increase or alteration, written or verbal, of the obligations of this Limited Warranty is authorized.

ADEMCO
GROUP
165 Eileen Way, Syosset, NY 11791
Copyright © 2001 Pittway Corporation

ÊK0724(Š
K0724 5/02