

**PACIFIC
SUPPORT
EQUIPMENT**



**Ours is a World of
Quality, Integrity,
Commitment,
and Pride.**

INTRODUCTION TO THE COMPANY

Pacific Support Equipment Ltd. (PSE) established in 1987 specializes in the manufacture of high quality Aero Engine Tooling, Industrial Gas Turbine Tooling, and Aircraft Ground Support Equipment, including our own proprietary line of Aircraft Towbars.

We have an excellent reputation for supplying high quality products on time and at a competitive cost. We have the ability to design and manufacture to the customer needs as well as being able to modify or refurbish existing equipment. We stand behind all of our manufactured products and offer complete after sales service.

Quality is a priority for all of our products. Our quality assurance program ensures consistent, accurate production during all of our manufacturing operations. Our certified proof load testing facility guarantees reliability of all of our load lifting and handling tools.

PRODUCT CATEGORIES

Our Ground Support Equipment products fall into four main categories:

- | | | |
|----|---------------------------------|---------------------|
| 1. | Aircraft Towbars | Reference Section A |
| 2. | Aero Engine Maintenance Tooling | Reference Section B |
| 3. | Aircraft Hanger Equipment | Reference Section C |
| 4. | Special Purpose Tooling | Reference Section D |

CONTACT INFORMATION

Pacific Support Equipment Ltd.
#15 – 12491 No. 2 Road
Richmond, B.C.
Canada
V7E 2G3

Phone: (604) 275-9131

Fax: (604) 275-0548

Website: www.pacificsupportltd.com

Email: pseltd@pacificsupportltd.com

SECTION A

AIRCRAFT TOWBARS

PSE's proprietary "Narrow Body" and "Wide Body" towbars offer you a total commonality of all running gear and hydraulics as well as towhead interchangeability for handling the wide range of aircraft sharing today's airport ramps. All of our towbars are accompanied with an operations manual complete with spare parts lists, shearpin data, and maintenance procedures.

All of our towbars and towhead equipment comply with the current SAE Specifications for ground support equipment as follows:

- general requirements for aerospace G.S.E. ARP 1247B
- minimum safety requirements for special purpose G.S.E. AIR 1375
- aerospace recommended practice ARP 1915
- commercial aircraft towbar attach interface AS 1614

Towbar features include:

- four ply pneumatic, foam filled, or solid rubber tires on steel wheels for the Narrow & Wide Body towbars and 10" or 12" solid rubber tires on steel wheels for the Regional aircraft towbars
- Enerpac hydraulic assisted wheel extension and spring retraction mechanism (on narrow & wide body towbars; optional on regional towbars)
- shearpin fail indicator (wide body towbars only)
- shock absorbing tractor toweyes to minimize shock loads to the NLG.
- spare shearpin storage bracket adjacent to towhead

Towhead features include:

- replaceable shearpin bushings
- heavy duty overcentering latching handle mechanism (narrow & wide body towheads only)
- size calibrated and gauged aircraft locking jaws (narrow & wide body towheads only)
- durable corrosion resistant "all weather" zinc finish

The following illustrations of the towbar equipment refer to all of the part numbers required for ordering complete towbar assemblies as well as complete listings of spare or replacement parts.

SECTION A

WIDE BODY TOWBARS



Illustration of a typical Wide Body Towbar complete with B747 towhead.

The wide bodied towbar is designed for airline ramp use on all wide bodied aircraft i.e. Boeing B747, B757, B767, B777, B787, McDonnell Douglas DC-10, MD-11, Lockheed L1011, Airbus A-300, A-310, A-330, A-340, and A380 aircraft. Each towbar includes torque and tow limiting shearpin designed and manufactured according to each aircraft manufacturers' specifications.

The towbar is well balanced and easy to maneuver around the ramp area with its wheels in the locked down position. After the towbar has been attached to the aircraft tow vehicle, these wheels are to be released to the raised position to give the required ground clearance during towing operation.

The towhead mechanism engages the landing gear towing lugs and locks in place with a spring loaded retaining latch. This latch may be released by hand to disengage the Nose Landing Gear (NLG).

The towbar is designed to handle all of the aircraft listed above to the maximum allowable towing loads. Each applicable shearpin value has been calculated to protect the NLG from both towing and torque overload. A cushioned swivel toweye allows attachment of the towbar to the tow vehicle hitch pin on uneven or inclined ramp surfaces.

SECTION A

The following is a summary list of Pacific Support Equipment's Wide Body Towbars:

Towbar Assemblies

<u>Listing:</u>	<u>Description</u>
PSE 170	Universal Wide Body Towbar Assembly (For use with interchangeable heads as listed below.)
PSE 170H	Heavy Duty Wide Body Towbar Assembly (For use with the A380 Aircraft Towhead Assembly)

Towhead Assemblies

<u>Listing:</u>	<u>Description</u>
PSE 171	B747 Towhead Assembly (picture as below)



PSE 172	"Universal" Towhead Assembly for use with B767 / B777 / B787 / DC10 / MD11 / L1011 aircraft.
---------	---



SECTION A

PSE 173

B757 Towhead Assembly



PSE 174

A310 Towhead Assembly

PSE 176

A330/A340 Towhead Assembly

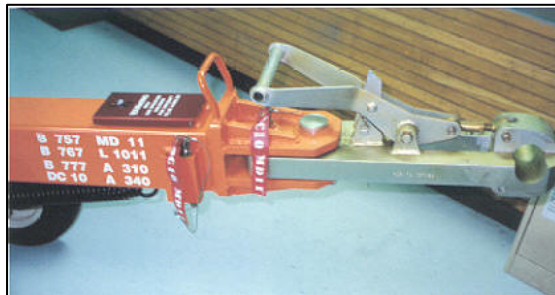

PSE 177

A330/340-500/600 Towhead Assembly



PSE 178

A300 Towhead Assembly

PSE 179

A380 Towhead Assembly (to be used with PSE-170H Heavy Duty Towbar Assembly)



SECTION A

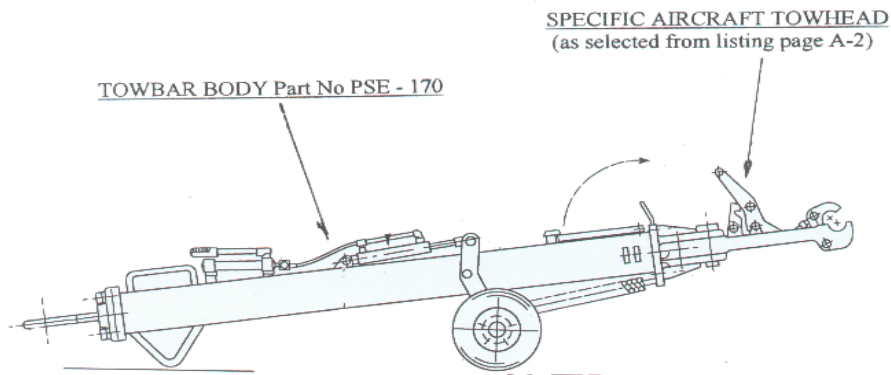

WIDE BODY AIRCRAFT TOWBAR CONFIGURATION

Wide Body Towbar Statistics

Fully assembled length	139 in. (353 cm)
Length without towhead	120 in. (305 cm)
Max C/L height (wheels down)	24 in. (61 cm)
Fully assembled weight	515 lbs. (234 kg)

Torque and Tow Limiting Shearpins

The wide body towbar utilizes a precision-machined shearpin for torque and tow limit protection of the aircraft nose landing gear. The shearpin is designed for easy replacement. The following part numbers should be referenced when ordering replacement shearpins.

Shearpin Ordering Data

<u>Part No.</u>	<u>Airbus Aircraft</u>	<u>Part No.</u>	<u>Boeing Aircraft</u>
PSE 178-12-1	A300	PSE 171-14-1	B747
PSE 174-12-1	A310	PSE 173-12-1	B757
PSE 176-12-1	A330	PSE 172-12-1	B767
PSE 177-12-1	A330-500/600	PSE 172-12-2	B777
PSE 176-12-1	A340	PSE 172-12-6	B787-3
PSE 177-12-1	A340-500/600	PSE 172-12-7	B787-8/9/9X
PSE 179-12-1	A380		
<u>Part No.</u>	<u>Lockheed</u>	<u>Part No.</u>	<u>MacDonnel Douglas</u>
PSE 172-12-5	L1011	PSE 172-12-3	DC 10
		PSE 172-12-4	MD11