



IRIG STANDARD 200-04

IRIG SERIAL TIME CODE FORMATS

**WHITE SANDS MISSILE RANGE
REAGAN TEST SITE
YUMA PROVING GROUND
DUGWAY PROVING GROUND
ABERDEEN TEST CENTER
NATIONAL TRAINING CENTER
ELECTRONIC PROVING GROUND**

**NAVAL AIR WARFARE CENTER WEAPONS DIVISION
NAVAL AIR WARFARE CENTER AIRCRAFT DIVISION
NAVAL UNDERSEA WARFARE CENTER DIVISION, NEWPORT
PACIFIC MISSILE RANGE FACILITY
NAVAL UNDERSEA WARFARE CENTER DIVISION, KEYPORT
NAVAL STRIKE AND AIR WARFARE CENTER**

**30TH SPACE WING
45TH SPACE WING
AIR FORCE FLIGHT TEST CENTER
AIR ARMAMENT CENTER
AIR WARFARE CENTER
ARNOLD ENGINEERING DEVELOPMENT CENTER
BARRY M. GOLDWATER RANGE
UTAH TEST AND TRAINING RANGE**

NATIONAL NUCLEAR SECURITY ADMINISTRATION (NEVADA)

**DISTRIBUTION A: APPROVED FOR PUBLIC RELEASE
DISTRIBUTION IS UNLIMITED**

This page intentionally left blank.

IRIG SERIAL TIME CODE FORMATS

SEPTEMBER 2004

Prepared by

**TIMING COMMITTEE
TELECOMMUNICATIONS AND TIMING GROUP
RANGE COMMANDERS COUNCIL**

Published by

**Secretariat
Range Commanders Council
U.S. Army White Sands Missile Range,
New Mexico 88002-5110**

THIS DOCUMENT IS AVAILABLE ON THE
RANGE COMMANDERS WEBSITE AT

<http://jcs.mil/RCC>

This page intentionally left blank.

CHANGES TO THIS EDITION

IRIG Standard 200-98 was last updated in May 1998 and defined the characteristics of the serial time codes A, B, D, E, G, and H. This 2004 edition of the Standard incorporates year information for codes A, B, E, and G. Codes D and H remain unchanged. The task of revising this standard was assigned to the Telecommunications and Timing Group (TTG) of the Range Commanders Council (RCC).

All U.S. Government ranges and facilities should adhere to this standard where serial time codes are generated for correlation of data with time.

This page intentionally left blank.

TABLE OF CONTENTS

| | |
|---|------------|
| CHANGES TO THIS EDITION | iii |
| LIST OF FIGURES | vi |
| LIST OF TABLES | vi |
| ACRONYMS AND ABBREVIATIONS..... | ix |
| CHAPTER 1: INTRODUCTION..... | 1-1 |
| CHAPTER 2: GENERAL DESCRIPTION OF THIS STANDARD..... | 2-1 |
| CHAPTER 3: GENERAL DESCRIPTION OF FORMATS | 3-1 |
| 3.1 Overview..... | 3-1 |
| 3.2 Time Code Formats..... | 3-1 |
| CHAPTER 4: DETAILED DESCRIPTION OF FORMATS | 4-1 |
| 4.1 Time Code Formats (A, B, D, E, and G) | 4-1 |
| 4.2 Examples Of Typical Modulated Carrier Signal Formats For IRIG A, B, E, and G... | 4-2 |
| 4.3 Manchester II Coding | 4-7 |
| 4.4 Manchester II Decoding..... | 4-9 |
| CHAPTER 5: GENERAL DESCRIPTION OF TIME CODES | 5-1 |
| 5.1 Introduction..... | 5-1 |
| 5.2 Time Code Format A | 5-1 |
| 5.3 Time Code Format B | 5-1 |
| 5.4 Time Code Format D | 5-2 |
| 5.5 Time Code Format E..... | 5-2 |
| 5.6 Time Code Format G | 5-3 |
| 5.7 Time Code Format H | 5-3 |
| CHAPTER 6: DETAILED DESCRIPTION OF TIME CODES..... | 6-1 |
| 6.1 Introduction..... | 6-1 |
| 6.2 Format A | 6-1 |
| 6.3 Format B | 6-6 |
| 6.4 Format D | 6-11 |
| 6.5 Format E..... | 6-14 |
| 6.6 Format G | 6-19 |
| 6.7 Format H | 6-24 |
| APPENDIX A: LEAP YEAR/LEAP SECOND CONVENTIONS | A-1 |
| 1.1 Leap Year Convention | A-1 |
| 1.2 Leap Second Convention | A-1 |
| APPENDIX B: BCD COUNT/BINARY COUNT..... | B-1 |

APPENDIX C: HARDWARE DESIGN CONSIDERATIONS..... C-1

GLOSSARY

- 1.1 Definitions of Terms And Usage
- 1.2 Time-related terms and the relationship between the various time scales

LIST OF FIGURES

| | | |
|-------------|--|------|
| Figure 3-1. | Typical modulated carrier signal. | 3-5 |
| Figure 4-1. | Serial time code formats | 4-1 |
| Figure 4-2. | IRIG B coding comparisons: level shift, 1kHz am, and Modified Manchester... 4-8 | |
| Figure 4-3. | Modified Manchester coding. | 4-8 |
| Figure 4-4. | A Manchester II Encoded Sequence | 4-9 |
| Figure 6-2. | Format B: BCD time-of-year in days, hours, minutes, seconds and year and straight binary seconds-of-day and control bits. | 6-7 |
| Figure 6-3. | Format D: BCD time-of-year in days and hours and control bits. | 6-12 |
| Figure 6-4. | Format E: BCD time-of-year in days, hours, minutes, seconds, and year and control bits. | 6-15 |
| Figure 6-5. | Format G: BCD Time-of-year in days, hours, minutes, seconds, and year and fractions-of-seconds, and control bits. | 6-20 |
| Figure 6-6. | Format H: BCD time-of-year in days, hours, minutes, and control bits. | 6-25 |

LIST OF TABLES

| | | |
|-------------|---|------|
| Table 3-1. | Bit Rates And Index Count Intervals Of The Time Code Formats..... | 3-1 |
| Table 3-2. | Time Frame Rates And Time Frame Intervals Of The Formats..... | 3-2 |
| Table 3-3. | Position Identifiers And Index Count Locations | 3-3 |
| Table 3-4. | Number Of Available Control Bits In Each Time Code Format | 3-3 |
| Table 3-5. | Typical Modulated Carrier Signal Formats For A, B, E, D, G, And H | 3-6 |
| Table 4-1. | Permissible Code Formats (A, B, D, E, G, H)..... | 4-2 |
| Table 4-2. | Typical Modulated Carrier Signal Formats (IRIG A)..... | 4-3 |
| Table 4-3. | Typical Modulated Carrier Signal Formats (IRIG B)..... | 4-4 |
| Table 4-4. | Typical Modulated Carrier Signal Formats (IRIG E)..... | 4-5 |
| Table 4-5. | Typical Modulated Carrier Signal Formats (IRIG G)..... | 4-6 |
| Table 4-6: | Truth Table Is A Modulo-2 Adder..... | 4-9 |
| Table 6-1. | Format A, Signal A000 | 6-3 |
| Table 6-2. | IRIG-A Control Bit Assignment For Year Information | 6-4 |
| Table 6-3. | Format A Control Functions (27 Bits) | 6-5 |
| Table 6-4. | Parameters For Format A..... | 6-5 |
| Table 6-5. | Format B, Signal B000 | 6-8 |
| Table 6-6. | IRIG-B Control Bit Assignment For Year Information..... | 6-9 |
| Table 6-7. | Format B Control Functions (45 Bits) | 6-10 |
| Table 6-8. | Parameters For Format B..... | 6-10 |
| Table 6-9. | Format D, Signal D001 | 6-13 |
| Table 6-10. | Parameters For Format D..... | 6-14 |
| Table 6-11. | Format E, Signal E001 | 6-16 |

| | | |
|-------------|---|------|
| Table 6-12. | IRIG-E Control Bit Assignment For Year Information | 6-17 |
| Table 6-13. | Format E Control Functions (45 Bits) | 6-18 |
| Table 6-14. | Parameters For Format E | 6-18 |
| Table 6-15. | Format G, Signal G001 | 6-21 |
| Table 6-16. | IRIG-G Control Bit Assignment For Year Information | 6-22 |
| Table 6-17. | Format G Control Functions (36 Bits) | 6-23 |
| Table 6-18. | Parameters For Format G..... | 6-23 |
| Table 6-19. | Format H, Signal H001 | 6-26 |
| Table 6-20. | Parameters For Format H..... | 6-27 |
| Table B-1. | Bcd Count (8n 4n 2n 1n)..... | B-1 |
| Table B-2. | Binary Count (2 ⁿ)..... | B-2 |
| Table C-1. | Time Code Generator Hardware Minimum Design Considerations..... | C-1 |

This page intentionally left blank.

ACRONYMS AND ABBREVIATIONS

ABBREVIATIONS (by category)

TERMS

| | |
|---------|---|
| CF | Control Function |
| Hz | An abbreviation for Hertz (Cycles per second) |
| k | 1000 |
| kHz | Kilohertz (1000 Hz) |
| fph | Frames per hour |
| fpm | Frames per minute |
| fps | Frames per second |
| pph | Pulses per hour |
| ppm | Pulses per minute |
| pps | Pulses per second |
| y | Year |
| mo | Month |
| d | Day |
| h | Hour |
| m | Minute |
| s | Second |
| ms | Millisecond (10^{-3} s) |
| μ s | Microsecond (10^{-6} s) |
| ns | Nanosecond (10^{-9} s) |
| DoY | Day-of-year |
| DoM | Day-of-month |
| HoD | Hour-of-day |
| MoH | Minutes-of-hour |
| SoD | Seconds-of-day (86.4×10^3) |
| MoD | Milliseconds-of-day (86.4×10^6) |
| MioD | Microseconds-of-day (86.4×10^9) |
| BCD | Binary coded decimal |
| SBS | Straight binary second(s) |
| SB | Straight binary |
| BIT | B(INARY + DIG)IT |
| LSB | Least significant bit |
| MSB | Most significant bit |
| NRZ-L | Non return to zero level |
| SBS | Straight binary time of day (seconds of day) |
| SB | Straight binary |

This page intentionally left blank.

CHAPTER 1

INTRODUCTION

Modern day electronic systems such as communication systems, data handling systems, and missile and spacecraft tracking systems require time-of-day and year information for correlation of data with time. Parallel and serial formatted time codes are used to efficiently interface the timing system output with the user system. Parallel time codes are defined in IRIG Standard 205-87, IRIG Standard Parallel Binary and Parallel Binary Coded Decimal Time Code Formats. Standardization of time codes is necessary to ensure system compatibility among the various ranges, ground tracking networks, spacecraft and missile projects, data reduction facilities, and international cooperative projects.

This standard defines the characteristics of six serial time codes presently used by the U.S. Government and private industry. Year information has been added to IRIG codes A, B, E, and G. It should be noted that this standard reflects the present state-of-the-art in serial time code formatting and is not intended to constrain proposals for new serial time codes with greater resolution.

All Department of Defense (DoD) test ranges, facilities, and other government agencies such as the National Aeronautics and Space Administration (NASA) maintain Coordinated Universal Time (UTC) referenced to the United States Naval Observatory (USNO) Master Clock. The designation for time in the United States is UTC (USNO).

This page intentionally left blank.

CHAPTER 2

GENERAL DESCRIPTION OF THIS STANDARD

This standard consists of a family of rate-scaled serial time codes with formats containing up to four coded expressions or words. All time codes contain control functions that are reserved for encoding various controls, identification, and other special purpose functions. Time codes A, B, D, E, G, and H are described below.

- Time code A has a time frame of 0.1 seconds with an index count of 1 millisecond and contains time-of-year and year information in a binary coded decimal (BCD) format, and seconds-of-day in straight binary seconds (SBS).
- Time code B has a time frame of 1 second with an index count of 10 milliseconds and contains time-of-year and year information in a BCD format, and seconds-of-day in SBS.
- Time code D has a time frame of 1 hour with an index count of 1 minute and contains time-of- year information in days and hours in a BCD format.
- Time code E has a time frame of 10 seconds with an index count of 100 milliseconds and contains time-of-year and year information in a BCD format.
- Time code G has a time frame of 0.01 seconds with an index count of 0.1 milliseconds and contains time-of year information in days, hours, minutes, seconds, fractions of seconds and year information in a BCD format.
- Time code H has a time frame of 1 minute with an index count of 1 second and contains time-of-year information in days, hours, and minutes in a binary coded decimal BCD format.

This page intentionally left blank.

CHAPTER 3

GENERAL DESCRIPTION OF FORMATS

3.1 Overview

A description of the time code formats is described in the subparagraphs below. Additional reference information is provided at the end of this document on the related topics of leap year and leap second conventions ([Appendix A](#)), Binary Coded Decimal (BCD) count data and binary count data ([Appendix B](#)), and time code generator hardware design considerations ([Appendix C](#)).

3.2 Time Code Formats

3.2.1 Pulse Rise Time. The specified pulse (dc level shift bit) rise time shall be obtained between the 10 and 90 percent amplitude points (see [Appendix C](#)).

3.2.2 Jitter. The modulated code is defined as ≤ 1 percent at the carrier frequency. The dc level shift code is defined as the pulse-to-pulse variation at the 50 percent amplitude points on the leading edges of successive pulses or bits (see [Appendix C](#)).

3.2.3 Bit Rates and Index Count. Each pulse in a time code word/sub-word is called a bit. The "on-time" reference point for all bits is the leading edge of the bit. The repetition rate at which the bits occur is called the bit rate. Each bit has an associated numerical index count identification. The time interval between the leading edge of two consecutive bits is the index count interval. The index count begins at the frame reference point with index count 0 and increases one count each index count until the time frame is complete.

The bit rates and index count intervals of the time code formats are shown in Table 3-1.

| TABLE 3-1. BIT RATES AND INDEX COUNT INTERVALS OF THE TIME CODE FORMATS | | |
|--|-----------------------------|-----------------------------|
| Format | Bit Rate¹ | Index Count Interval |
| A | 1 kpps | 1 millisecond |
| B | 100 pps | 10 milliseconds |
| D | 1 ppm | 1 minute |
| E | 10 pps | 0.1 second |
| G | 10 kpps | 0.1 millisecond |
| H | 1 pps | 1 second |

¹ See the abbreviations and acronyms page at the beginning of this document for bit rate definitions

3.2.4 Time Frame, Time Frame Reference, and Time Frame Rates. A time code frame begins with a frame reference marker P_0 (position identifier) followed by a reference bit P_r with each having duration equal to 0.8 of the index count interval of the respective code. The on-time

reference point of a time frame is the leading edge of the reference bit P_r . The repetition rate at which the time frames occur is called the time frame rate. The time frame rates and time frame intervals of the formats are shown in Table 3-2.

| TABLE 3-2. TIME FRAME RATES AND TIME FRAME INTERVALS OF THE FORMATS | | |
|--|------------------------|----------------------------|
| Format | Time Frame Rate | Time Frame Interval |
| A | 10 fps | 0.1 second |
| B | 1 fps | 1 second |
| D | 1 fph | 1 hour |
| E | 6 fpm | 10 seconds |
| G | 100 fps | 10 ms |
| H | 1 fpm | 1 minute |

3.2.5 Position Identifiers. Position identifiers have durations equal to 0.8 of the index count interval of the respective code. The leading edge of the position identifier P_0 occurs one index count interval before the frame reference point P_r and the succeeding position identifiers ($P_2, P_2...P_0$) occur every succeeding tenth bit. The repetition rate at which the position identifiers occur is always 0.1 of the time format bit rate.

3.2.6 Time Code Words. The two time code words employed in this standard are:

- Binary Coded Decimal (BCD) time-of-year and year
- Straight Binary Seconds (SBS) time-of-day (seconds-of-day)

All time code formats are pulse-width coded. A binary (1) bit has duration equal to 0.5 of the index count interval, and a binary (0) bit has duration equal to 0.2 of the index count interval. The BCD time-of-year code reads 0 hours, minutes, seconds, and fraction of seconds at 2400 each day and reads day 001 at 2400 of day 365 or day 366 in a leap year. The year code counts year and cycles to the next year on January 1st of each year and will count to year 2099. The SBS time-of-day code reads 0 seconds at 2400 each day excluding leap second days when a second may be added or subtracted.

3.2.7 BCD Time-of-Year Code Word. The BCD time-of-year and year code word consists of sub-words in days, hours, minutes, seconds, and year with fractions of a second in a BCD representation and time-of-day in SBS of day. The position identifiers preceding the decimal digits and the index count locations of the decimal digits (if present) are in Table 3-3.

Formats A and B include an optional SBS time code word in addition to a BCD time-of-year time and year code word. The SBS word follows position identifier P_8 beginning with the least significant binary bit (2^0) at index count 80 and progressing to the most significant binary bit (2^{16}) at index count 97 with a position identifier P_9 occurring between the ninth (2^8) and tenth (2^9) binary bits. Codes A, B, E, and G also contain year information in a BCD format and are an extension to the time-of-year format.

| TABLE 3-3. POSITION IDENTIFIERS AND INDEX COUNT LOCATIONS | | |
|--|--|--|
| BCD Code Decimal Digits | Decimal Digits Follow Position Identifier | Digits Occupy Index Count Positions |
| Units of seconds Tens of Seconds | P ₀ | 1-4 6-8 |
| Units of Minutes Tens of Minutes | P ₁ | 10-13 15-17 |
| Units of Hours Tens of Hours | P ₂ | 20-23 25-26 |
| Units of Days Tens of Days | P ₃ | 30-33 35-38 |
| Hundreds of Days Tenths of Seconds | P ₄ | 40-41 45-48 |
| Hundredths of Seconds | P ₅ | 50-53 |
| For Codes A, B, and E Tens of Years Hundredths of Years | P ₅ | 51-54 56-59 |
| For Code G Tens of Year Hundredths of Year | P ₆ | 61-64 66-69 |

3.2.8 Control Functions. All time code formats reserve a set of bits known as control functions (CF) for the encoding of various control, identification, and other special purpose functions. The control bits may be programmed in any predetermined coding system. A binary 1 bit has duration equal to 0.5 of the index count interval, and a binary (0) bit has duration equal to 0.2 of the index count interval. Control function bits follow position identifiers P₅, P₆ or P₇ for formats A, B, E, and G beginning at index count 50, 60 or 70 with one control function bit per index count, except for each tenth bit which is a position identifier. The number of available control bits in each time code format is shown at Table 3-4.

| TABLE 3-4. NUMBER OF AVAILABLE CONTROL BITS IN EACH TIME CODE FORMAT | |
|---|--------------------------|
| Format | Control Functions |
| A | 18 |
| B | 18 |
| D | 9 |
| E | 36 |
| G | 27 |
| H | 9 |

Control functions are presently intended for internal range use, but not for interranging applications; therefore, no standard coding system exists. The inclusion of control functions into a time code format as well as the coding system employed is an individual user defined option.

3.2.9 Index Markers. Index markers occur at each index count position, which is not assigned as a reference marker, position identifier, code, or control function bit. Each index marker bit has duration equal to 0.2 of the index count interval of the respective time code format.

3.2.10 Amplitude Modulated Carrier. A standard sine wave carrier frequency to be amplitude modulated by a time code is synchronized to have positive-going, zero-axis crossings coincident with the leading edges of the modulating code bits. A mark-to-space ratio of 10:3 is standard with a range of 3:1 to 6:1 (see Typical Modulated Carrier Signal descriptions at Figure [3-1](#) and Table [3-5](#)).

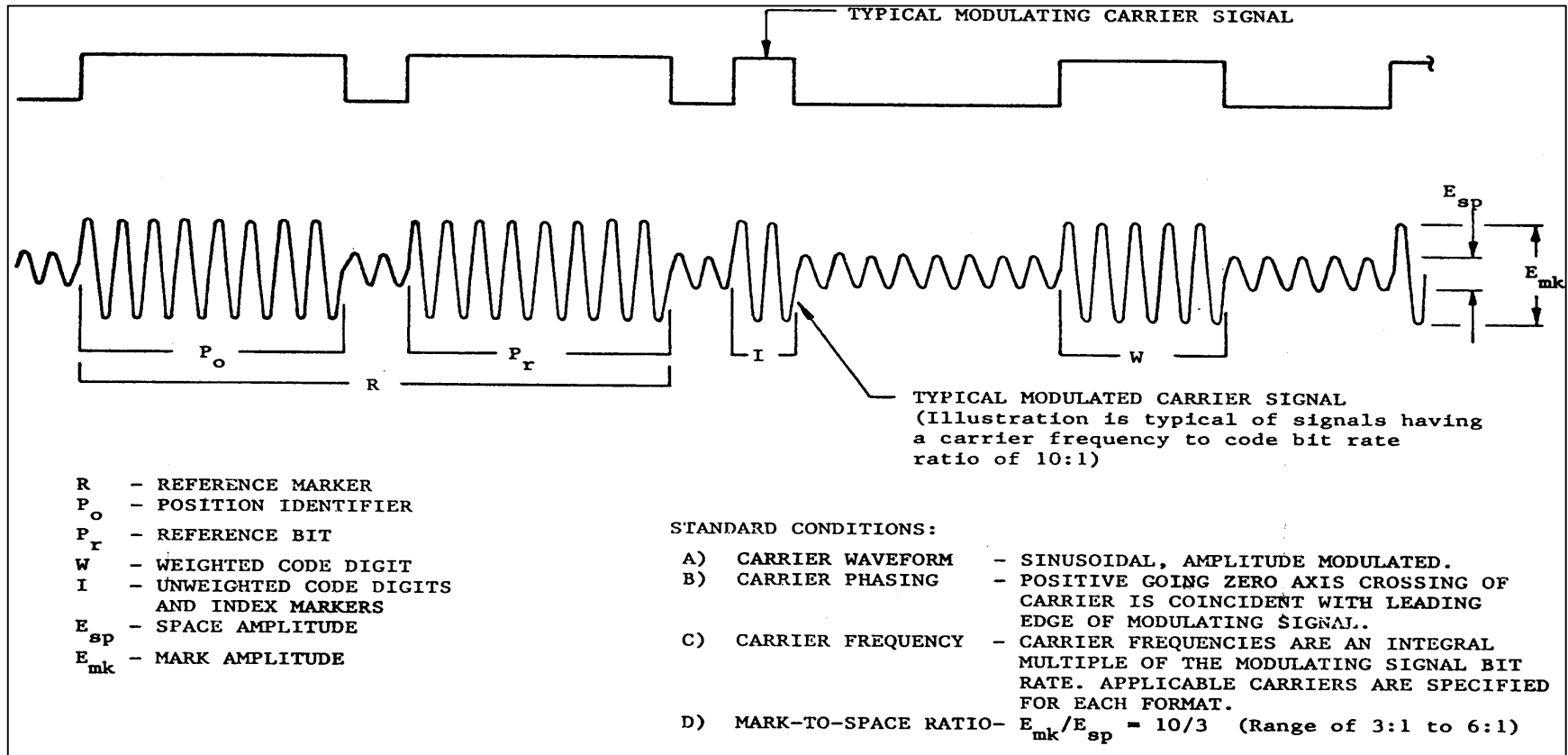

Figure 3-1. Typical modulated carrier signal.

TABLE 3-5. TYPICAL MODULATED CARRIER SIGNAL FORMATS FOR A, B, E, D, G, AND H

| FORMATS | | | | | MARK INTERVAL NUMBER OF CYCLES | | | |
|---------|---------------------------|-----------------------|---------------------------|--------------------------|-----------------------------------|------------------------|---------------|----------------------------------|
| FORMAT | SIGNAL NO. | TIME FRAME RATE | CARRIER FREQUENCY F | SIGNAL BIT RATE ER | RATIO F/ER | CODE "0" & INDEX | CODE "1" | POSITION IDENTIFIER & REF. |
| A | A130, 132 133, 134 | 10 per sec. | 10 kHz | 1 kpps | 10:1 | 2 | 5 | 8 |
| B | B120, 122 123, 127 | 1 per sec. | 1 kHz | 100 pps | 10:1 | 2 | 5 | 8 |
| D | D111, 112 121,122 | 1 per hr. | 100Hz 1kHz | 1 ppm 1 ppm | 6000:1 60000:1 | 1200 12000 | 3000 30000 | 4800 48000 |
| E | E111, 112 121,122, 125 | 6 per min | 100Hz 1kHz | 10 pps 10 pps | 10:1 100:1 | 2 20 | 5 50 | 8 80 |
| G | G141, 142, 126 | 100 per sec. | 100 kHz | 10 kpps | 10:1 | 2 | 5 | 8 |
| H | H111, 112 121,122 | 1 per min. | 100 Hz 1 kHz | 1 pps 1 pps | 100:1 1000:1 | 20 200 | 50 500 | 80 800 |

CHAPTER 4

DETAILED DESCRIPTION OF FORMATS

4.1 Time Code Formats (A, B, D, E, and G)

4.1.1 Serial Time Code Formats. The family of rate-scaled serial time code formats is designated A, B, D, E, G, and H. Various combinations of sub-words and signal forms make up a time code word. All formats do not contain each standard coded expression, and various signal forms are possible. To differentiate between these forms, signal identification numbers are assigned to each permissible combination (see Figure 4-1).

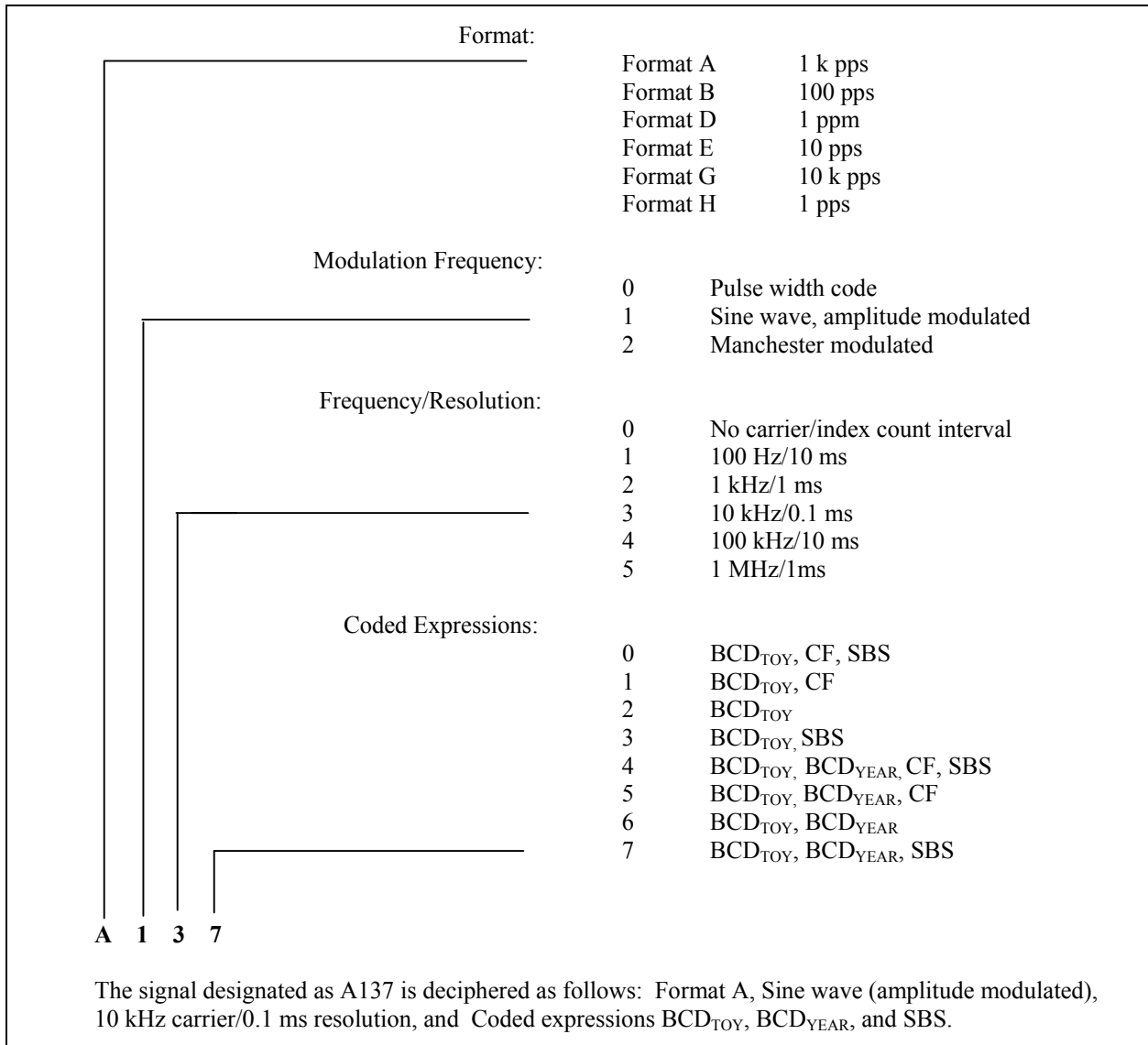

Figure 4-1. Serial time code formats

4.1.2 Manchester Time Code Formats. The resolution of a time code is that of the smallest increment of time or the least significant bit that can be defined by a time code word or sub-word. The accuracy of a modified, Manchester time code can be determined by the rise-time of the on-time pulse in the Manchester code which marks the beginning of the on-time one-pulse-per-second as shown in Figure 3-1 above. The accuracy can range from milliseconds to nanoseconds or better depending on equipment and measurement technique. For the case of the unmodulated Manchester codes, the Position Marker PO, which marks the beginning of the second, can be used.

The information in Table 4-1 shows the permissible code formats. Codes D, and H remain unchanged. Codes A, B, E and G have changed to permit year information as indicated below. No other combinations are standard.

| TABLE 4-1. PERMISSIBLE CODE FORMATS (A, B, D, E, G, H) | | | |
|---|-----------------------------|-----------------------------|--------------------------|
| Format | Modulation Frequency | Frequency/Resolution | Coded Expressions |
| A | 0, 1, 2 | 0, 3, 4, 5 | 0, 1, 2, 3, 4, 5, 6, 7 |
| B | 0, 1, 2 | 0, 2, 3, 4, 5 | 0, 1, 2, 3, 4, 5, 6, 7 |
| D | 0, 1 | 0, 1, 2 | 1, 2 |
| E | 0, 1 | 0, 1, 2 | 1, 2, 5, 6 |
| G | 0, 1, 2 | 0, 4, 5 | 1, 2, 5, 6 |
| H | 0, 1 | 0, 1, 2 | 1, 2 |

The Telecommunications and Timing Group (TTG) of the Range Commanders Council (RCC) has adopted a Modified Manchester modulation technique as an option for the IRIG serial time codes A, B, and G as an addition to the standard AM modulation and level shift modulation now permitted. Also, year information has been added to codes A, B, E, and G. Codes D and H remain unchanged. It should be noted that at present, the assignment of control bits (control functions) to specific functions in the IRIG serial time codes is left to the end-user of the time codes.

4.2 Examples Of Typical Modulated Carrier Signal Formats For IRIG A, B, E, and G

Examples are provided on the following pages as follows:

- IRIG A: Table [4-2](#)
- IRIG B: Table [4-3](#)
- IRIG E: Table [4-4](#)
- IRIG G: Table [4-5](#)

TABLE 4-2. TYPICAL MODULATED CARRIER SIGNAL FORMATS (IRIG A)

| Modified Manchester Modulations¹ | |
|--|---|
| A 237 | 2 = Manchester modulation 3 = 10 kHz/0.1 ms 7 = BCD _{TOY} , BCD _{YEAR} , SBS |
| Standard AM modulations (Example Formats) | |
| A130 | 1 = Sine wave, amplitude modulated 3 = 10 kHz/0.1 ms 0 = BCD _{TOY} , CF, SBS |
| A 134 | 1 = Sine wave, amplitude modulated 3 = 10 KHz/0.1 ms 4 = BCD _{TOY} , BCD _{YEAR} , CF, SBS |
| A 132 | 1 = Sine wave, amplitude modulated 3 = 10 kHz/0.1 ms 2 = BCD _{TOY} |
| A 136 | 1 = Sine wave, amplitude modulated 3 = 10 kHz/0.1 ms 6 = BCD _{TOY} , BCD _{YEAR} |
| A 133 | 1 = Sine wave, amplitude modulated 3 = 10 kHz/0.1 ms 3 = BCD _{TOY} , SBS |
| A 137 | 1 = Sine wave, amplitude modulated 3 = 10 kHz/0.1ms 7 = BCD _{TOY} , BCD _{YEAR} , SBS |
| A 131 | 1 = Sine wave, amplitude modulated 3 = 10 kHz/0.1ms 1 = BCD _{TOY} , CF |
| A 135 | 1 = Sine wave, amplitude modulated 3 = 10 kHz/0.1 ms 5 = BCD _{TOY} , BCD _{YEAR} , CF |
| ¹ Modified Manchester modulation is an option for IRIG A in addition to the standard AM modulation in the formats in this table | |

TABLE 4-3. TYPICAL MODULATED CARRIER SIGNAL FORMATS (IRIG B)

| Modified Manchester Modulations¹ | |
|---|--|
| B 237 | 2 = Manchester modulation 3 = 10 kHz/0.1 ms 7 = BCD _{TOY} , BCD _{YEAR} , SBS |
| Standard AM modulations (Example Formats) | |
| B120 | 1 = Sine wave, amplitude modulated 2 = 1 kHz/1 ms 0 = BCD _{TOY} , CF, SBS |
| B 124 | 1 = Sine wave, amplitude modulated 2 = 1 kHz/1 ms 4 = BCD _{TOY} , BCD _{YEAR} , CF, SBS |
| B 121 | 1 = Sine wave, amplitude modulated 2 = 1 kHz/1 ms 1 = BCD _{TOY} , CF |
| B 125 | 1 = Sine wave. Amplitude modulated 2 = 1 kHz/1 ms 5 = BCD _{TOY} , BCD _{YEAR} , CF |
| B 122 | 1 = Sine wave, amplitude modulated 2 = 1 kHz/1 ms 2 = BCD _{TOY} |
| B 126 | 1 = Sine wave, amplitude modulated 2 = 1 kHz/1 ms 6 = BCD _{TOY} , BCD _{YEAR} |
| B 123 | 1 = Sine wave, amplitude modulated 2 = 1 kHz/1 ms 3 = BCD _{TOY} SBS |
| B 127 | 1 = Sine wave, amplitude modulated 2 = 1 kHz/1 ms 7 = BCD _{TOY} , BCD _{YEAR} , SBS |
| ¹ Modified Manchester modulation is an option for IRIG B in addition to the standard AM modulation in the formats in this table. | |

TABLE 4-4. TYPICAL MODULATED CARRIER SIGNAL FORMATS (IRIG E)

| Standard AM modulations (Example Formats) | |
|--|---|
| E 111 | 1 = Sine wave, amplitude modulated 1 = 100 Hz/10 ms 1 = BCD _{TOY} , CF |
| E115 | 1 = Sine wave, amplitude modulated 1 = 100 Hz/10 ms 5 = BCD _{TOY} , BCD _{YEAR} , CF |
| E 112 | 1 = Sine wave, amplitude modulated 1 = 100 Hz/10 ms 2 = BCD _{TOY} , |
| E 116 | 1 = Sine wave, amplitude modulated 1 = 100 Hz/10 ms 6 = BCD _{TOY} , BCD _{YEAR} |
| E 121 | 1 = Sine wave, amplitude modulated 2 = 1kHz/1 ms 1 = BCD _{TOY} , CF |
| E 125 | 1 = Sine wave, amplitude modulated 2 = 1kHz/1 ms 5 = BCD _{TOY} , BCD _{YEAR} , CF |
| E 122 | 1 = Sine wave, amplitude modulated 2 = 1kHz/1 ms 2 = BCD _{TOY} |
| E 126 | 1 = Sine wave, amplitude modulated 2 = 1kHz/1ms 6 = BCD _{TOY} , BCD _{YEAR} |

TABLE 4-5. TYPICAL MODULATED CARRIER SIGNAL FORMATS (IRIG G)

| Modified Manchester Modulations¹ | |
|--|---|
| G 245 | 2 = Manchester modulation 4 = 100 kHz/10 ms 5 = BCD _{TOY} , BCD _{YEAR} , CF |
| Standard AM modulations (Example Formats) | |
| G 141 | 1 = Sign wave, amplitude modulation 4 = 100 kHz/10 ms 1 = BCD _{TOY} , CF |
| G 145 | 1 = Sign wave, amplitude modulation 4 = 100 kHz/10 ms 5 = BCD _{TOY} , BCD _{YEAR} , CF |
| G 142 | 1 = Sign wave, amplitude modulated 4 = 100 kHz/10 ms 2 = BCD _{TOY} |
| G 146 | 1 = Sign wave, amplitude modulated 4 = 100 kHz/10 ms 6 = BCD _{TOY} , BCD _{YEAR} |
| ¹ Modified Manchester modulation is an option for IRIG G in addition to the standard AM modulation in the formats in this table | |

4.3 Manchester II Coding

Standard Manchester modulation or encoding is a return-to-zero type, where a rising edge in the middle of the clock window indicates a binary one (1) and a falling edge indicates a binary zero (0). This modification to the Manchester code shifts the data window so the data are at the edge of the clock window that is on time with the one-pulse-per-second clock synchronized to Coordinated Universal Time (UTC). Thus, the data edge is the on-time mark in the code. Because this code is easy to generate digitally, easy to modulate onto fiber or coaxial cable, simple to decode, and has a zero mean, and the code is easy to detect even at low voltage levels.

The basic Modified Manchester modulation, compared with the AM and level shift modulations are shown at Figure [4-2](#) and Figure [4-3](#). The Manchester encoding uses a square-wave as the encoding (data) clock, with the rising edge on time with UTC. The frequency of the encoding clock shall be ten times the index rate of the time code generated. As an example, the clock rate for IRIG B230 shall be 10 kHz.

The Modified Manchester coding technique has several advantages as noted below.

- No dc component
- Can be ac coupled
- Better signal-to-noise ratio
- Good spectral power density
- Easily decoded
- Better timing resolution
- The link integrity monitoring capability is intrinsic to bipolar pulse modulation.
- The coding technique is designed to operate over fiber-optic or coaxial lines for short distances.

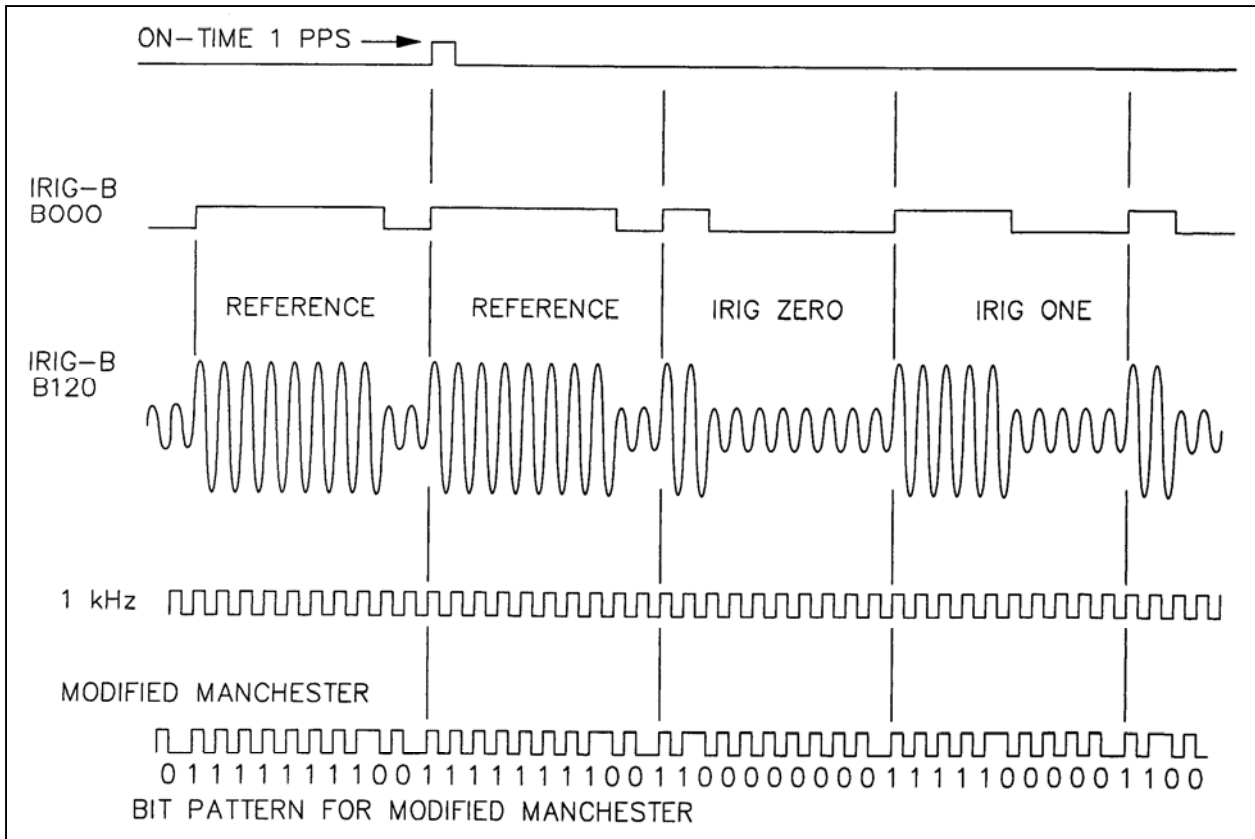

Figure 4-2. IRIG B coding comparisons: level shift, 1kHz am, and Modified Manchester.

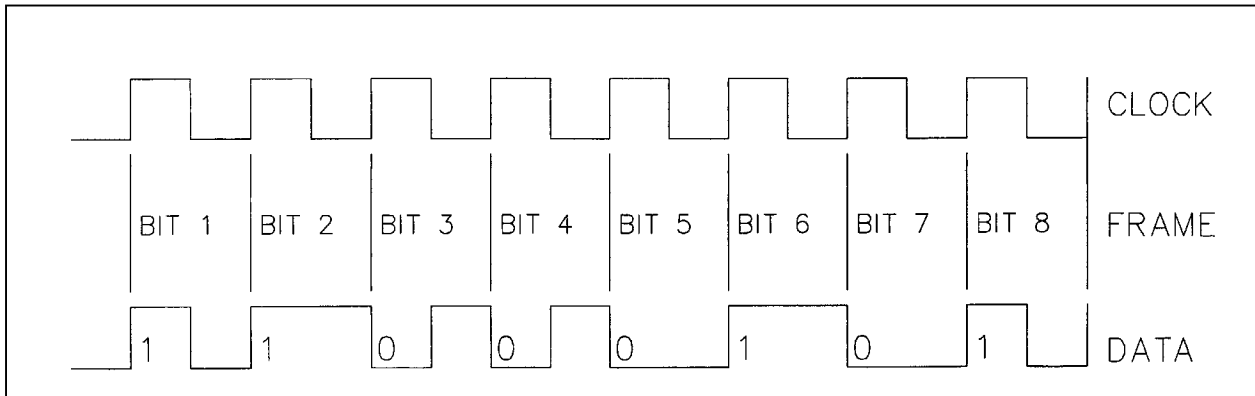

Figure 4-3. Modified Manchester coding.

4.4 Manchester II Decoding

An example of a Manchester II encoded sequence is shown at Figure 4-4, where each symbol is “sub-bit” encoded, i.e., a data one equals a zero-one, and a data zero equals a one-zero:

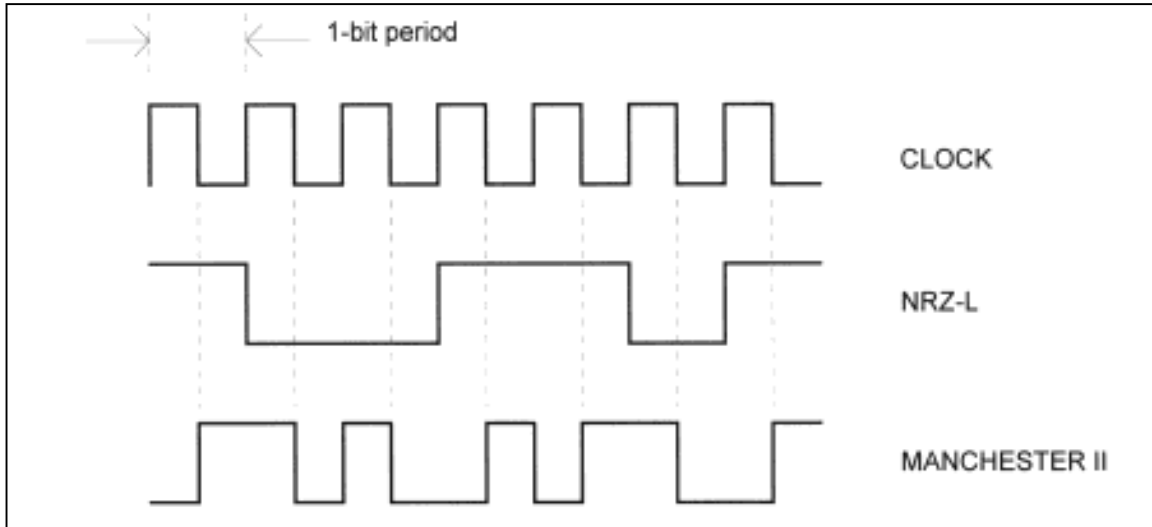

Figure 4-4. A Manchester II Encoded Sequence

The encoded sequence at Figure 4-4 is formed by modulo-2 adding the NRZ-L sequence with the clock. The truth table shown in Table 4-6 is for a modulo-2 adder, which is equivalent to an Exclusive-OR (XOR).

| TABLE 4-6: TRUTH TABLE IS A MODULO-2 ADDER | | |
|--|---------|--------|
| INPUT A | INPUT B | OUTPUT |
| 0 | 0 | 0 |
| 0 | 1 | 1 |
| 1 | 0 | 1 |
| 1 | 1 | 0 |

To decode the encoded sequence of Figure 4-4, it is only necessary to modulo-2 add the clock with the encoded sequence and the original NRZ-L sequence results. It should be noted that the bit determination is made after integrating across a bit period. In this way, the maximum amount of bit energy is used in the determination of each bit. Likewise, one could have integrated or sampled both halves of the encoded sequence and reconstructed the original Non Return To Zero Level (NRZ-L) sequence by applying the encoding rule. This means that if sampled halves are 0-1, then a data 1 is reconstructed, and if the sampled halves are 1-0, then a data 0 is reconstructed. Once again, as much energy as possible is used from the encoded

sequence to reconstruct the original NRZ-L sequence. This procedure minimizes the probability of error.



When the above procedure is used, the reconstructed data are coherent with the clock; that is, the NRZ-L data transitions will agree with the positive going edge of the clock. However, since the decisions are made at the end of the symbol period, the reconstructed NRZ-L data are delayed one clock period; this means that when the entire time is received, the received time code or local clock needs to be advanced by one clock period. Also, if desired, one can correct the receive clock for significant signal propagation delays.

CHAPTER 5

GENERAL DESCRIPTION OF TIME CODES

5.1 Introduction

A general description of individual time code formats is described in the following sub-paragraphs. Year information has been added to formats A, B, E and G in 1, 2, 4, 8 and 10, 20, 40, 80 BCD bits using the unassigned Control Function (CF) BITS. This permits a year count from 2000 to 2099. If users desire the “Century Year” information, they can use two binary coded decimal BCD CF bits with a value of 0, 2, and 3. Therefore, a user wanting to start with year 2000 can count to year 2399.

5.2 Time Code Format A

5.2.1 The 78-bit time code contains 34 bits of BCD time-of-year information in days, hours, minutes and tenths of seconds, 17 bits of straight binary seconds-of-day (SBS), and 9 bits for year information in BCD. The remaining 18 bits are for control functions.

5.2.2 The BCD code (seconds sub-word) begins at index count 1 (LSB first) with binary coded bits occurring between position identifier P_0 and P_5 . There are 7 bits for seconds, 7 for minutes, 6 for hours, 10 for days, 4 for tenths of seconds, and 9 for year information between position identifiers P_5 and P_6 to complete the BCD word. An index marker occurs between the decimal digits in each sub-word, except for the tenths of seconds, to provide for visual separation. The BCD time-of-year code recycles yearly.

5.2.3 The SBS word begins at index count 80 and is between position identifiers P_8 and P_0 with a position identifier bit, P_9 between the 9th and 10th binary SBS coded bits. The SBS time code recycles each 24-hour period.

5.2.4 The eighteen control bits occur between position identifiers P_6 and P_8 with a position identifier occurring every 10 bits.

5.2.5 The frame rate or repetition rate is 0.1 seconds with resolutions of 1 ms (dc level shift) and 0.1 ms (modulated 10 kHz carrier).

5.3 Time Code Format B

5.3.1 The 74-bit time code contains 30 bits of BCD time-of-year information in days, hours, minutes and seconds, 17 bits of SB seconds-of-day, 9 bits for year information and 18 bits for control functions.

5.3.2 The BCD code (seconds sub-word) begins at index count 1 (LSB first) with binary coded bits occurring between position identifier bits P_0 and P_6 : 7 for seconds, 7 for minutes, 6 for hours, 10 for days and 9 for year information between position identifiers P_5 and P_6 to complete the BCD word. An index marker occurs between the decimal digits in each sub-word to provide separation for visual resolution.

5.3.3 The SBS word begins at index count 80 and is between position identifiers P_8 and P_0 with a position identifier bit, P_9 between the 9th and 10th SBS coded bits. The SBS time code recycles each 24-hour period.

5.3.4 The eighteen control bits occur between position identifiers P_6 and P_8 with a position identifier every 10 bits.

5.3.5 The frame rate is 1.0 seconds with resolutions of 10 ms (dc level shift) and 1 ms (modulated 1 kHz carrier).

5.4 Time Code Format D

5.4.1 The 25-bit time code contains 16 bits of BCD Time-of-year information in days, hours, minutes and 9 bits for control functions.

5.4.2 The BCD code (hours sub-word) begins at index count 20 (LSB first) with binary coded bits occurring between position identifier bits P_2 and P_5 : 6 for hours and 10 for days to complete the BCD word. An index marker occurs between the decimal digits in each sub-word for visual resolution. The BCD time-of-year code recycles yearly.

5.4.3 The nine control bits occur between position identifiers P_5 and P_0 .

5.4.4 The frame rate is one hour with resolutions of 1 minute (dc level shift), 10 ms (modulated 100 Hz carrier) and 1 ms (modulated 1 kHz carrier).

5.5 Time Code Format E

5.5.1 The 71-bit time code contains 26 bits of BCD time-of-year information in days, hours, minutes, and seconds, 9 bits for year information, and 36 bits for control functions between position identifiers P_6 and P_0 .

5.5.2 The BCD code (seconds sub-word) begins at index count 6 (LSB first). Binary coded Bits occur between position identifiers P_0 and P_5 : 3 bits for tens of seconds, 7 for minutes, 6 for hours, 10 for days and 9 bits for year information between position identifiers P_5 and P_6 to complete the BCD word. An index marker occurs between the decimal digits in each sub-word to provide visual resolution. The BCD time-of-year code recycles yearly.

5.5.3 The eighteen control bits occur between position identifiers P_6 and P_0 .

5.5.4 The frame rate is 10 seconds with resolutions of 0.1 seconds (dc level shift), 10 ms (modulated 100 Hz carrier), and 1 ms (modulated 1 kHz carrier).

5.6 Time Code Format G

5.6.1 The 74-bit time code contains 38 bits of BCD time-of-year information in days, hours, minutes, seconds, and fraction of seconds, 9 bits of year information, and 27 bits for control functions.

5.6.2 The BCD code (seconds sub-word) begins at index count 1 (LSB first). Binary coded bits occur between position identifiers P_0 and P_6 : 7 bits for seconds, 7 for minutes, 6 for hours, 10 for days, 4 for tenths of seconds, 4 for hundredths of seconds and 9 for year information between position identifiers P_6 and P_7 to complete the BCD word. An index marker occurs between the decimal digits in each sub-word (except fractional seconds) to provide for visual resolution. The BCD time-of-year code recycles yearly.

5.6.3 The twenty-seven control bits occur between position identifiers P_7 and P_0 .

5.6.4 The frame rate is 10 ms with resolutions of 0.1 ms (dc level shift) and 10s (100 kHz carrier).

5.7 Time Code Format H

5.7.1 The 32-bit time code word contains 23 bits of BCD time-of-year information in days, hours, and minutes and 9 bits for control functions.

5.7.2 The BCD code (minutes sub-word) begins at index count 10 (LSB first) with binary coded bits occurring between position identifier bits P_1 and P_5 : 7 bits for minutes, 6 for hours, and 10 for days to complete the BCD word. An index marker occurs between decimal digits in each sub-word to provide separation for visual resolution. The time code recycles yearly.

5.7.3 The nine control bits occur between position identifiers P_5 and P_0 .

5.7.4 The frame rate is 1 minute with resolutions of 1 second (dc level shift), 10 ms (modulated 100 Hz carrier) and 1 ms (modulated 1 kHz carrier).

This page intentionally left blank.

CHAPTER 6

DETAILED DESCRIPTION OF TIME CODES

6.1 Introduction

Detailed descriptions of individual time code formats are shown in the following paragraphs.

6.2 Format A

6.2.1 The beginning of each 0.1 second time frame is identified by two consecutive 0.8 ms bits, P_0 and P_r . The leading edge of P_r is the on-time reference point for the succeeding time code words. Position identifiers, P_0 and P_1 through P_9 , (0.8 ms duration) occur every 10th bit and 1 ms before the leading edge of each succeeding 100 pps on-time bit (see Figure [6-1](#)).

6.2.2 The three time code words and the control functions presented during the time frame are pulse width coded. The binary zero and index markers have duration of 0.2 ms, and the binary one has duration of 0.5 ms. The 1 k pps leading edge is the on-time reference point for all bits.

6.2.3 The binary coded decimal (BCD) time-of-year coded word consists of 34 bits beginning at index count one. The time-of-year sub-word bits occur between position identifiers P_0 and P_5 : 7 bits for seconds, 7 for minutes, 6 for hours, 10 for days, 4 for tenths of seconds. Nine bits for year information occur between position identifiers P_5 and P_6 to complete the BCD time code word. An index marker occurs between the decimal digits in each sub-word, except tenths of seconds, to provide separation for visual resolution. The LSB occurs first except for the fractional seconds sub-word that follows the day-of-year sub-word. The BCD time-of-year code recycles yearly.

6.2.4 Eighteen control bits occur between position identifiers P_6 and P_8 . Any control function bit or combination of bits can be programmed to read a binary one or a binary zero during any specified number of frames. Each control bit position is identified in Table [6-1](#).

6.2.5 The straight binary (SB) seconds-of-day code word occurs at index count 80 between position identifiers P_8 and P_0 . Seventeen bits give time-of-day in seconds with the LSB occurring first. A position identifier occurs between the 9th and 10th binary seconds. The code recycles each 24-hour period.

6.2.6 Control bit assignments, functions, and parameters for time code Format A are shown on the following pages as:

Table [6-2](#): Identifies the control bit assignments for year information.

Table [6-3](#): Identifies the control functions (for 27 bits).

Table [6-4](#): Identifies the parameters that characterize the time code for Format A.

TABLE 6-1. FORMAT A, SIGNAL A000

| BCD TIME-OF-YEAR CODE (34 DIGITS) | | | | | | | | | | | | | | |
|--------------------------------------|-----------------------------------|---------------------------|---------------------------|---------------------------|---------------|--|------------------------|---------------|-------------------------------------|-----------------------|---------------|---------------------------|-----------------------|---------------|
| SECONDS SUBWORD | | | MINUTES SUBWORD | | | HOURS SUBWORD | | | DAYS AND FRACTIONAL SECOND SUBWORDS | | | | | |
| BCD Code Digit No. | Subword Digit Wt SECONDS | BIT Time (Note 1) | BCD Code Digit No. | Subword Digit Wt MINUTES | BIT Time | BCD Code Digit No. | Subword Digit Wt HOURS | BIT Time | BCD Code Digit No. | Subword Digit Wt DAYS | BIT Time | BCD Code Digit No. | Subword Digit Wt DAYS | BIT Time |
| Reference BIT | | P_r | 8 | 1 | $P_r + 10$ ms | 15 | 1 | $P_r + 20$ ms | 21 | 1 | $P_r + 30$ ms | 29 | 100 | $P_r + 40$ ms |
| 1 | 1 | $P_r + 1$ ms | 9 | 2 | $P_r + 11$ ms | 16 | 2 | $P_r + 21$ ms | 22 | 2 | $P_r + 31$ ms | 30 | 200 | $P_r + 41$ ms |
| 2 | 2 | $P_r + 2$ ms | 10 | 4 | $P_r + 12$ ms | 17 | 4 | $P_r + 22$ ms | 23 | 4 | $P_r + 32$ ms | Index BIT | | $P_r + 42$ ms |
| 3 | 4 | $P_r + 3$ ms | 11 | 8 | $P_r + 13$ ms | 18 | 8 | $P_r + 23$ ms | 24 | 8 | $P_r + 33$ ms | Index BIT | | $P_r + 43$ ms |
| 4 | 8 | $P_r + 4$ ms | Index BIT | | $P_r + 14$ ms | Index BIT | | $P_r + 24$ ms | Index BIT | | $P_r + 34$ ms | Index BIT | | $P_r + 44$ ms |
| Index BIT | | $P_r + 5$ ms | 12 | 10 | $P_r + 15$ ms | 19 | 10 | $P_r + 25$ ms | 25 | 10 | $P_r + 35$ ms | 31 | 0.1 | $P_r + 45$ ms |
| 5 | 10 | $P_r + 6$ ms | 13 | 20 | $P_r + 16$ ms | 20 | 20 | $P_r + 26$ ms | 26 | 20 | $P_r + 36$ ms | 32 | 0.2 | $P_r + 46$ ms |
| 6 | 20 | $P_r + 7$ ms | 14 | 40 | $P_r + 17$ ms | Index BIT | | $P_r + 27$ ms | 27 | 40 | $P_r + 37$ ms | 33 | 0.4 | $P_r + 47$ ms |
| 7 | 40 | $P_r + 8$ ms | Index BIT | | $P_r + 18$ ms | Index BIT | | $P_r + 28$ ms | 28 | 80 | $P_r + 38$ ms | 34 | 0.8 | $P_r + 48$ ms |
| Position Ident. (P_1) | | $P_r + 9$ ms | Position Ident. (P_2) | | $P_r + 19$ ms | Position Ident. (P_3) | | $P_r + 29$ ms | Position Ident. (P_4) | | $P_r + 39$ ms | Position Ident. (P_5) | | $P_r + 49$ ms |
| YEAR AND CONTROL FUNCTIONS (27 BITS) | | | | | | STRAIGHT BINARY SECONDS TIME-OF-DAY CODE (17 DIGITS) | | | | | | | | |
| Control Function BIT | BIT Time | Control Function BIT | BIT Time | Control Function BIT | BIT Time | SB Code BIT | Subword Digit Weight | BIT Time | SB Code BIT | Subword Digit Weight | BIT Time | | | |
| 1 | $P_r + 50$ ms Units of Year 01 | 10 | $P_r + 60$ ms | 19 | $P_r + 70$ ms | 1 | $2^0 = (1)$ | $P_r + 80$ ms | 10 | $2^9 = (512)$ | $P_r + 90$ ms | | | |
| 2 | Units of Year 02 | 11 | $P_r + 61$ ms | 20 | $P_r + 71$ ms | 2 | $2^1 = (2)$ | $P_r + 81$ ms | 11 | $2^{10} = (1024)$ | $P_r + 91$ ms | | | |
| 3 | Units of Year 04 | 12 | $P_r + 62$ ms | 21 | $P_r + 72$ ms | 3 | $2^2 = (4)$ | $P_r + 82$ ms | 12 | $2^{11} = (2048)$ | $P_r + 92$ ms | | | |
| 4 | Units of Year 08 | 13 | $P_r + 63$ ms | 22 | $P_r + 73$ ms | 4 | $2^3 = (8)$ | $P_r + 83$ ms | 13 | $2^{12} = (4096)$ | $P_r + 93$ ms | | | |
| 5 | $P_r + 54$ ms | 14 | $P_r + 64$ ms | 23 | $P_r + 74$ ms | 5 | $2^4 = (16)$ | $P_r + 84$ ms | 14 | $2^{13} = (8192)$ | $P_r + 94$ ms | | | |
| 6 | Tens of Year 10 | 15 | $P_r + 65$ ms | 24 | $P_r + 75$ ms | 6 | $2^5 = (32)$ | $P_r + 85$ ms | 15 | $2^{14} = (16384)$ | $P_r + 95$ ms | | | |
| 7 | Tens of Year 20 | 16 | $P_r + 66$ ms | 25 | $P_r + 76$ ms | 7 | $2^6 = (64)$ | $P_r + 86$ ms | 16 | $2^{15} = (32768)$ | $P_r + 96$ ms | | | |
| 8 | Tens of Year 40 | 17 | $P_r + 67$ ms | 26 | $P_r + 77$ ms | 8 | $2^7 = (128)$ | $P_r + 87$ ms | 17 | $2^{16} = (65536)$ | $P_r + 97$ ms | | | |
| 9 | Tens of Year 80 | 18 | $P_r + 68$ ms | 27 | $P_r + 78$ ms | 9 | $2^8 = (256)$ | $P_r + 88$ ms | Index BIT | | $P_r + 98$ ms | | | |
| Position Ident. (P_6) | $P_r + 59$ ms | Position Ident. (P_7) | $P_r + 69$ ms | Position Ident. (P_8) | $P_r + 79$ ms | Position Ident. (P_9) | | $P_r + 89$ ms | Position Ident. (P_{10}) | | $P_r + 99$ ms | | | |

Note 1. The BIT Time is the time of the BIT leading edge and refers to the leading edge of P_r .

TABLE 6-2. IRIG-A CONTROL BIT ASSIGNMENT FOR YEAR INFORMATION

| POS. ID | CTRL BIT NO | DESIGNATION | EXPLANATION |
|--|-------------|--------------|------------------------------|
| P0 to P5 is BCD Time-of-year in seconds, minutes, hours, days, and fractional seconds. | | | |
| P49 | -- | P5 | Position Identifier # 5 |
| P50 | 1 | Year, BCD 1 | Last 2 digits of year in BCD |
| P51 | 2 | Year, BCD 2 | IBID |
| P52 | 3 | Year, BCD 4 | IBID |
| P53 | 4 | Year, BCD 8 | IBID |
| P54 | 5 | Not Used | Unassigned |
| P55 | 6 | Year, BCD 10 | Last 2 digits of year in BCD |
| P56 | 7 | Year, BCD 20 | IBID |
| P57 | 8 | Year, BCD 40 | IBID |
| P58 | 9 | Year, BCD 80 | IBID |
| P59 | -- | P6 | Position Identifier # 6 |
| P60 | 10 | Not Used | Unassigned |
| P61 | 11 | IBID | IBID |
| P62 | 12 | IBID | IBID |
| P63 | 13 | IBID | IBID |
| P64 | 14 | IBID | IBID |
| P65 | 15 | IBID | IBID |
| P66 | 16 | IBID | IBID |
| P67 | 17 | IBID | IBID |
| P68 | 18 | IBID | IBID |
| P69 | -- | P7 | Position Identifier # 7 |
| P70 | 19 | Not Used | Unassigned |
| P71 | 20 | IBID | IBID |
| P72 | 21 | IBID | IBID |
| P73 | 22 | IBID | IBID |
| P74 | 23 | IBID | IBID |
| P75 | 24 | IBID | IBID |
| P76 | 25 | IBID | IBID |
| P77 | 26 | IBID | IBID |
| P78 | 27 | IBID | IBID |
| P79 | -- | P8 | Position Identifier # 8 |
| P6 to P8 are control functions | | | |
| P8 to P0 is Time-of-Day in Straight Binary Seconds. | | | |

TABLE 6-3. FORMAT A CONTROL FUNCTIONS (27 BITS)

| Control Function BIT | BIT Time | Control Function BIT | BIT Time | Control Function BIT | BIT Time |
|---------------------------|-----------------------------------|---------------------------|---------------|---------------------------|---------------|
| 1 | Units of Year 01 $P_r + 50$ ms | 10 | $P_r + 60$ ms | 19 | $P_r + 70$ ms |
| 2 | Units of Year 02 | 11 | $P_r + 61$ ms | 20 | $P_r + 71$ ms |
| 3 | Units of Year 04 | 12 | $P_r + 62$ ms | 21 | $P_r + 72$ ms |
| 4 | Units of Year 08 | 13 | $P_r + 63$ ms | 22 | $P_r + 73$ ms |
| 5 | $P_r + 54$ ms | 14 | $P_r + 64$ ms | 23 | $P_r + 74$ ms |
| 6 | Tens of Year 10 | 15 | $P_r + 65$ ms | 24 | $P_r + 75$ ms |
| 7 | Tens of Year 20 | 16 | $P_r + 66$ ms | 25 | $P_r + 76$ ms |
| 8 | Tens of Year 40 | 17 | $P_r + 67$ ms | 26 | $P_r + 77$ ms |
| 9 | Tens of Year 80 | 18 | $P_r + 68$ ms | 27 | $P_r + 78$ ms |
| Position Ident. (P_6) | $P_r + 59$ ms | Position Ident. (P_7) | $P_r + 69$ ms | Position Ident. (P_8) | $P_r + 79$ ms |

Note: The BIT Time is the time of the BIT leading edge and refers to the leading edge of P_r .

TABLE 6-4. PARAMETERS FOR FORMAT A

| Pulse Rates | Pulse Duration |
|--|--|
| Bit rate: 1 k pps Position identifier rate: 100 pps Reference marker: 10 pps | Index marker: 0.2 ms Binary zero or unencoded bit: 0.2 ms Binary one or coded bit: 0.5 ms Position identifiers: 0.8 ms Reference bit: 0.8 ms |
| Resolution | Mark-To-Space Ratio |
| 1 ms dc level 0.1 ms modulated 10 kHz carrier | Nominal value of 10:3 Range of 3:1 to 6:1 |

6.3 Format B

6.3.1 The beginning of each 1.0 second time frame is identified by two consecutive 8.0 ms bits, P_0 and P_r . The leading edge of P_r is the on-time reference point for the succeeding time code words. Position identifiers, P_0 and P_1 through P_9 , (8 ms duration) occur every 10th bit and 10 ms before the leading edge of each succeeding 10 pps "on-time" bits (see Figure [6-2](#)).

6.3.2 The three time code words and the control functions presented during the time frame are pulse width coded. The binary zero and the index markers have duration of 2.0 ms, and a binary one has duration of 5.0 ms. The 100 pps leading edge is the on-time reference point for all bits.

6.3.3 The BCD time-of-year code word consists of 30 bits beginning at index count one. The sub-word bits occur between position identifiers P_0 and P_5 ; there are 7 bits for seconds, 7 for minutes, 6 for hours, and 10 for days. Nine bits for year information occur between position identifiers P_5 and P_6 to complete the BCD time code word. An index marker occurs between the decimal digits in each sub-word to provide separation for visual resolution. The LSB occurs first. The BCD time-of-year code recycles yearly. Each bit position is identified in Table [6-5](#).

6.3.4 Eighteen control functions occur between position identifiers P_6 and P_8 . Any control function bit or combination of bits can be programmed to read a binary one or zero during any specified number of time frames.

6.3.5 The SB seconds-of-day word occurs between position identifier P_8 and P_0 . A position identifier occurs between the 9th and 10th binary coded bit. The code recycles each 24-hour period.

6.3.6 Control bit assignments, functions, and parameters for time code format B are shown on the following pages as:

Table [6-6](#): Identifies the control bit assignments for year information.

Table [6-7](#): Identifies the control functions (for 27 bits).

Table [6-8](#): Identifies the parameters that characterize the time code for Format A.

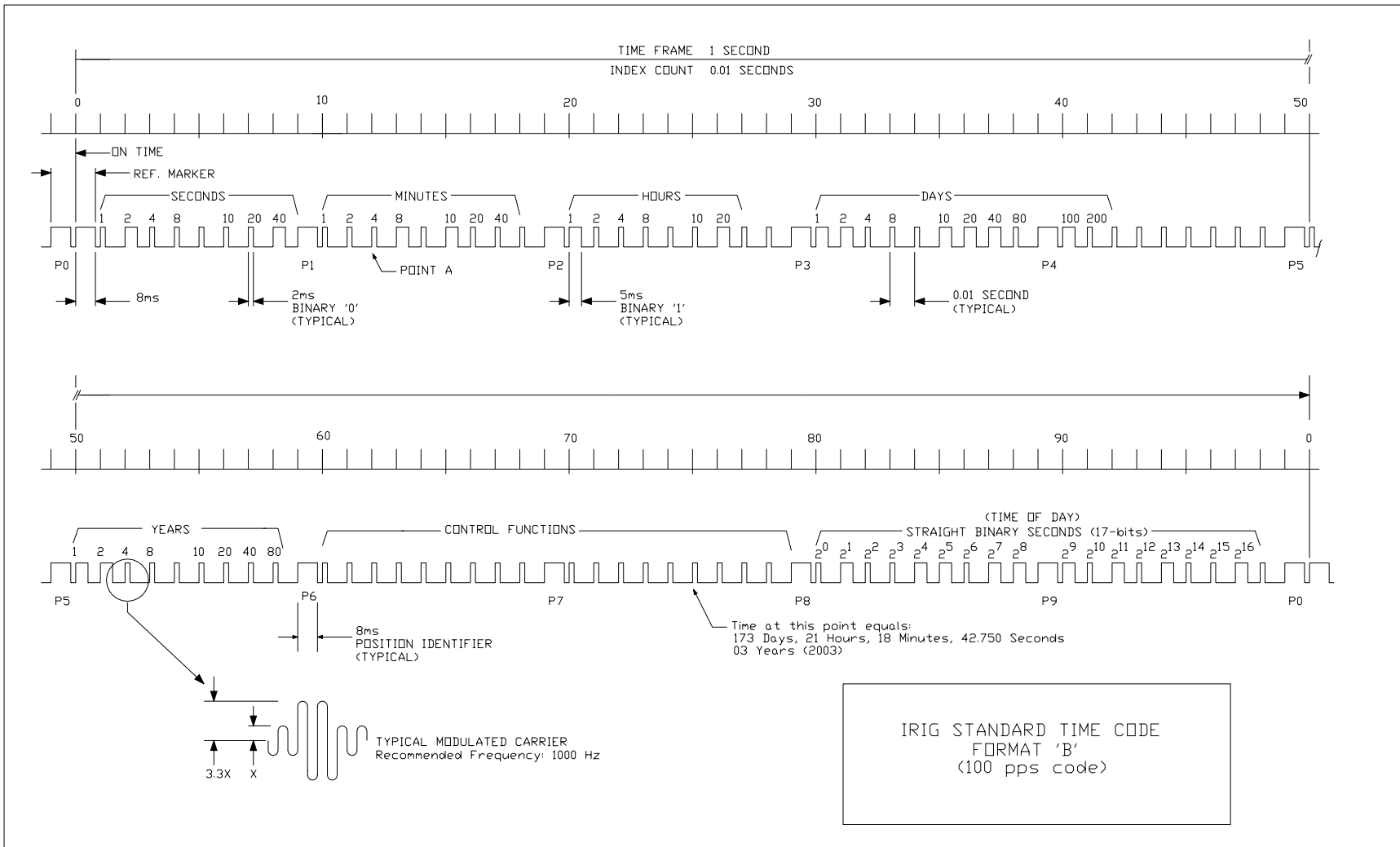

Figure 6-2. Format B: BCD time-of-year in days, hours, minutes, seconds and year and straight binary seconds-of-day and control bits.

TABLE 6-5. FORMAT B, SIGNAL B000

| BCD TIME-OF-YEAR CODE (30 DIGITS) | | | | | | | | | | | | | | |
|--------------------------------------|---------------------------------|---------------------------|---------------------------|---------------------------|----------------|--|------------------------|----------------|---------------------------|-----------------------|----------------|---------------------------|-----------------------|----------------|
| SECONDS SUBWORD | | | MINUTES SUBWORD | | | HOURS SUBWORD | | | DAYS SUBWORD | | | | | |
| BCD Code Digit No. | Subword Digit Wt SECONDS | BIT Time (Note 1) | BCD Code Digit No. | Subword Digit Wt MINUTES | BIT Time | BCD Code Digit No. | Subword Digit Wt HOURS | BIT Time | BCD Code Digit No. | Subword Digit Wt DAYS | BIT Time | BCD Code Digit No. | Subword Digit Wt DAYS | BIT Time |
| Reference BIT | | P_r | 8 | 1 | $P_r + 100$ ms | 15 | 1 | $P_r + 200$ ms | 21 | 1 | $P_r + 300$ ms | 29 | 100 | $P_r + 400$ ms |
| 1 | 1 | $P_r + 10$ ms | 9 | 2 | $P_r + 110$ ms | 16 | 2 | $P_r + 210$ ms | 22 | 2 | $P_r + 310$ ms | 30 | 200 | $P_r + 410$ ms |
| 2 | 2 | $P_r + 20$ ms | 10 | 4 | $P_r + 120$ ms | 17 | 4 | $P_r + 220$ ms | 23 | 4 | $P_r + 320$ ms | Index BIT | | $P_r + 420$ ms |
| 3 | 4 | $P_r + 30$ ms | 11 | 8 | $P_r + 130$ ms | 18 | 8 | $P_r + 230$ ms | 24 | 8 | $P_r + 330$ ms | Index BIT | | $P_r + 430$ ms |
| 4 | 8 | $P_r + 40$ ms | Index BIT | | $P_r + 140$ ms | Index BIT | | $P_r + 240$ ms | Index BIT | | $P_r + 340$ ms | Index BIT | | $P_r + 440$ ms |
| Index BIT | | $P_r + 50$ ms | 12 | 10 | $P_r + 150$ ms | 19 | 10 | $P_r + 250$ ms | 25 | 10 | $P_r + 350$ ms | Index BIT | | $P_r + 450$ ms |
| 5 | 10 | $P_r + 60$ ms | 13 | 20 | $P_r + 160$ ms | 20 | 20 | $P_r + 260$ ms | 26 | 20 | $P_r + 360$ ms | Index BIT | | $P_r + 460$ ms |
| 6 | 20 | $P_r + 70$ ms | 14 | 40 | $P_r + 170$ ms | Index BIT | | $P_r + 270$ ms | 27 | 40 | $P_r + 370$ ms | Index BIT | | $P_r + 470$ ms |
| 7 | 40 | $P_r + 80$ ms | Index BIT | | $P_r + 180$ ms | Index BIT | | $P_r + 280$ ms | 28 | 80 | $P_r + 380$ ms | Index BIT | | $P_r + 480$ ms |
| Position Ident. (P_1) | | $P_r + 90$ ms | Position Ident. (P_2) | | $P_r + 190$ ms | Position Ident. (P_3) | | $P_r + 290$ ms | Position Ident. (P_4) | | $P_r + 390$ ms | Position Ident. (P_5) | | $P_r + 490$ ms |
| YEAR AND CONTROL FUNCTIONS (27 BITS) | | | | | | STRAIGHT BINARY SECONDS TIME-OF-DAY CODE (17 DIGITS) | | | | | | | | |
| Control Function BIT | BIT Time | Control Function BIT | BIT Time | Control Function BIT | BIT Time | SB Code BIT | Sub-word Digit Weight | BIT Time | SB Code BIT | Subword Digit Weight | BIT Time | | | |
| 1 | $P_r + 500$ ms Units of Year 01 | 10 | $P_r + 600$ ms | 19 | $P_r + 700$ ms | 1 | $2^0 = (1)$ | $P_r + 800$ ms | 10 | $2^9 = (512)$ | $P_r + 900$ ms | | | |
| 2 | Units of Year 02 | 11 | $P_r + 610$ ms | 20 | $P_r + 710$ ms | 2 | $2^1 = (2)$ | $P_r + 810$ ms | 11 | $2^{10} = (1024)$ | $P_r + 910$ ms | | | |
| 3 | Units of Year 04 | 12 | $P_r + 620$ ms | 21 | $P_r + 720$ ms | 3 | $2^2 = (4)$ | $P_r + 820$ ms | 12 | $2^{11} = (2048)$ | $P_r + 920$ ms | | | |
| 4 | Units of Year 08 | 13 | $P_r + 630$ ms | 22 | $P_r + 730$ ms | 4 | $2^3 = (8)$ | $P_r + 830$ ms | 13 | $2^{12} = (4096)$ | $P_r + 930$ ms | | | |
| 5 | $P_r + 540$ ms | 14 | $P_r + 640$ ms | 23 | $P_r + 740$ ms | 5 | $2^4 = (16)$ | $P_r + 840$ ms | 14 | $2^{13} = (8192)$ | $P_r + 940$ ms | | | |
| 6 | Tens of Year 10 | 15 | $P_r + 650$ ms | 24 | $P_r + 750$ ms | 6 | $2^5 = (32)$ | $P_r + 850$ ms | 15 | $2^{14} = (16384)$ | $P_r + 950$ ms | | | |
| 7 | Tens of Year 20 | 16 | $P_r + 660$ ms | 25 | $P_r + 760$ ms | 7 | $2^6 = (64)$ | $P_r + 860$ ms | 16 | $2^{15} = (32768)$ | $P_r + 960$ ms | | | |
| 8 | Tens of Year 40 | 17 | $P_r + 670$ ms | 26 | $P_r + 770$ ms | 8 | $2^7 = (128)$ | $P_r + 870$ ms | 17 | $2^{16} = (65536)$ | $P_r + 970$ ms | | | |
| 9 | Tens of Year 80 | 18 | $P_r + 680$ ms | 27 | $P_r + 780$ ms | 9 | $2^8 = (256)$ | $P_r + 880$ ms | Index BIT | | $P_r + 980$ ms | | | |
| Position Ident. (P_6) | $P_r + 590$ ms | Position Ident. (P_7) | $P_r + 690$ ms | Position Ident. (P_8) | $P_r + 790$ ms | Position Ident. (P_9) | | $P_r + 890$ ms | Position Ident. (P_0) | | $P_r + 990$ ms | | | |

8-6

Note 1: The BIT Time is the time of the BIT leading edge and refers to the leading edge of P_r

TABLE 6-6. IRIG-B CONTROL BIT ASSIGNMENT FOR YEAR INFORMATION

| POS. ID | CTRL BIT NO | DESIGNATION | EXPLANATION |
|---|-------------|--------------|------------------------------|
| P0 to P5 is BCD Time-of-Year in Seconds, Minutes, Hours and Days. | | | |
| P49 | -- | P5 | Position Identifier # 5 |
| P50 | 1 | Year, BCD 1 | Last 2 digits of year in BCD |
| P51 | 2 | Year, BCD 2 | IBID |
| P52 | 3 | Year, BCD 4 | IBID |
| P53 | 4 | Year, BCD 8 | IBID |
| P54 | 5 | Not Used | Unassigned |
| P55 | 6 | Year, BCD 10 | Last 2 digits of year in BCD |
| P56 | 7 | Year, BCD 20 | IBID |
| P57 | 8 | Year, BCD 20 | IBID |
| P58 | 9 | Year, BCD 20 | IBID |
| P59 | -- | P6 | Position Identifier # 6 |
| P60 | 10 | Not Used | Unassigned |
| P61 | 11 | IBID | IBID |
| P62 | 12 | IBID | IBID |
| P63 | 13 | IBID | IBID |
| P64 | 14 | IBID | IBID |
| P65 | 15 | IBID | IBID |
| P66 | 16 | IBID | IBID |
| P67 | 17 | IBID | IBID |
| P68 | 18 | IBID | IBID |
| P69 | -- | P7 | Position Identifier # 7 |
| P70 | 19 | Not Used | Unassigned |
| P71 | 20 | IBID | IBID |
| P72 | 21 | IBID | IBID |
| P73 | 22 | IBID | IBID |
| P74 | 23 | IBID | IBID |
| P75 | 24 | IBID | IBID |
| P76 | 25 | IBID | IBID |
| P77 | 26 | IBID | IBID |
| P78 | 27 | IBID | IBID |
| P79 | -- | P8 | Position Identifier # 8 |
| P6 to P8 are control functions | | | |
| P8 to P0 is Time-of-Day in Straight Binary Seconds. | | | |

TABLE 6-7. FORMAT B CONTROL FUNCTIONS (45 BITS)

| Control Function BIT | BIT Time | Control Function BIT | BIT Time | Control Function BIT | BIT Time |
|------------------------------|-------------------------------------|------------------------------|-----------------|------------------------------|-----------------|
| 1 | Units of Year 01 $P_r + 5.0$ sec | 10 | $P_r + 6.0$ sec | 19 | $P_r + 7.0$ sec |
| 2 | Units of Year 02 | 11 | $P_r + 6.1$ sec | 20 | $P_r + 7.1$ sec |
| 3 | Units of Year 03 | 12 | $P_r + 6.2$ sec | 21 | $P_r + 7.2$ sec |
| 4 | Units of Year 04 | 13 | $P_r + 6.3$ sec | 22 | $P_r + 7.3$ sec |
| 5 | $P_r + 5.4$ sec | 14 | $P_r + 6.4$ sec | 23 | $P_r + 7.4$ sec |
| 6 | Tens of Year 10 | 15 | $P_r + 6.5$ sec | 24 | $P_r + 7.5$ sec |
| 7 | Tens of Year 20 | 16 | $P_r + 6.6$ sec | 25 | $P_r + 7.6$ sec |
| 8 | Tens of Year 40 | 17 | $P_r + 6.7$ sec | 26 | $P_r + 7.7$ sec |
| 9 | Tens of Year 80 | 18 | $P_r + 6.8$ sec | 27 | $P_r + 7.8$ sec |
| Position Ident. (P_6) | $P_r + 5.9$ sec | Position Ident. (P_7) | $P_r + 6.9$ sec | Position Ident. (P_8) | $P_r + 7.9$ sec |
| Control Function BIT | BIT Time | Control Function BIT | BIT Time | Control Function BIT | BIT Time |
| 28 | $P_r + 8.0$ sec | 37 | $P_r + 9.0$ sec | BLANK | BLANK |
| 29 | $P_r + 8.1$ sec | 38 | $P_r + 9.1$ sec | | |
| 30 | $P_r + 8.2$ sec | 39 | $P_r + 9.2$ sec | | |
| 31 | $P_r + 8.3$ sec | 40 | $P_r + 9.3$ sec | | |
| 32 | $P_r + 8.4$ sec | 42 | $P_r + 9.4$ sec | | |
| 33 | $P_r + 8.5$ sec | 42 | $P_r + 9.5$ sec | | |
| 34 | $P_r + 8.6$ sec | 43 | $P_r + 9.6$ sec | | |
| 35 | $P_r + 8.7$ sec | 44 | $P_r + 9.7$ sec | | |
| 35 | $P_r + 8.8$ sec | 45 | $P_r + 9.8$ sec | | |
| Position Ident. (P_9) | $P_r + 8.9$ sec | Position Ident. (P_0) | $P_r + 9.9$ sec | | |

TABLE 6-8. PARAMETERS FOR FORMAT B

| Pulse Rates | Pulse Duration |
|---|--|
| Bit rate: 100 pps Position identifier: 10 pps Reference mark: 1 pps | Index marker: 2 ms Binary zero or unencoded bit: 2 ms Binary one or coded bit: 5 ms Position identifiers: 8 ms Reference bit: 8 ms |
| Resolution | Mark-To-Space Ratio |
| 10 ms dc level 1 ms modulated 1 kHz carrier | Nominal value of 10:3 Range of 3:1 to 6:1 |

6.4 Format D

6.4.1 The beginning of each 2-hour time frame is identified by two consecutive 48-second bits, P_0 and P_r . The leading edge of P_r is the on-time point for the succeeding time code word. Position identifiers, P_0 and P_1 through P_5 , occur every 10th bit and one minute before the leading edge of each succeeding 6 pulses per hour (pph) on-time bit (see Figure [6-3](#)).

6.4.2 The time code word and the control bits presented during the time frame are pulse width coded. The binary zero and the index markers each have duration of 12 seconds and the binary one has duration of 30 seconds. The 1-ppm leading edge is the on-time reference point for all bits.

6.4.3 The BCD time-of-year code consists of 16 bits beginning at index count 20. The sub-word bits occur between position identifiers P_2 and P_5 : 6 for hours and 10 for days to complete the time code word. An index marker occurs between the decimal digits in each sub-word to provide separation for visual resolution. The LSB occurs first. The code recycles yearly. Each bit position is identified in Table [6-9](#).

6.4.4 Nine control bits occur between position identifiers P_5 and P_0 . Any control function bit or combination of bits can be programmed to read a binary one or zero during any specified number of time frames.

6.4.5 Details of the IRIG Format D parameters that characterize the time code for Format D are shown in Table [6-10](#).

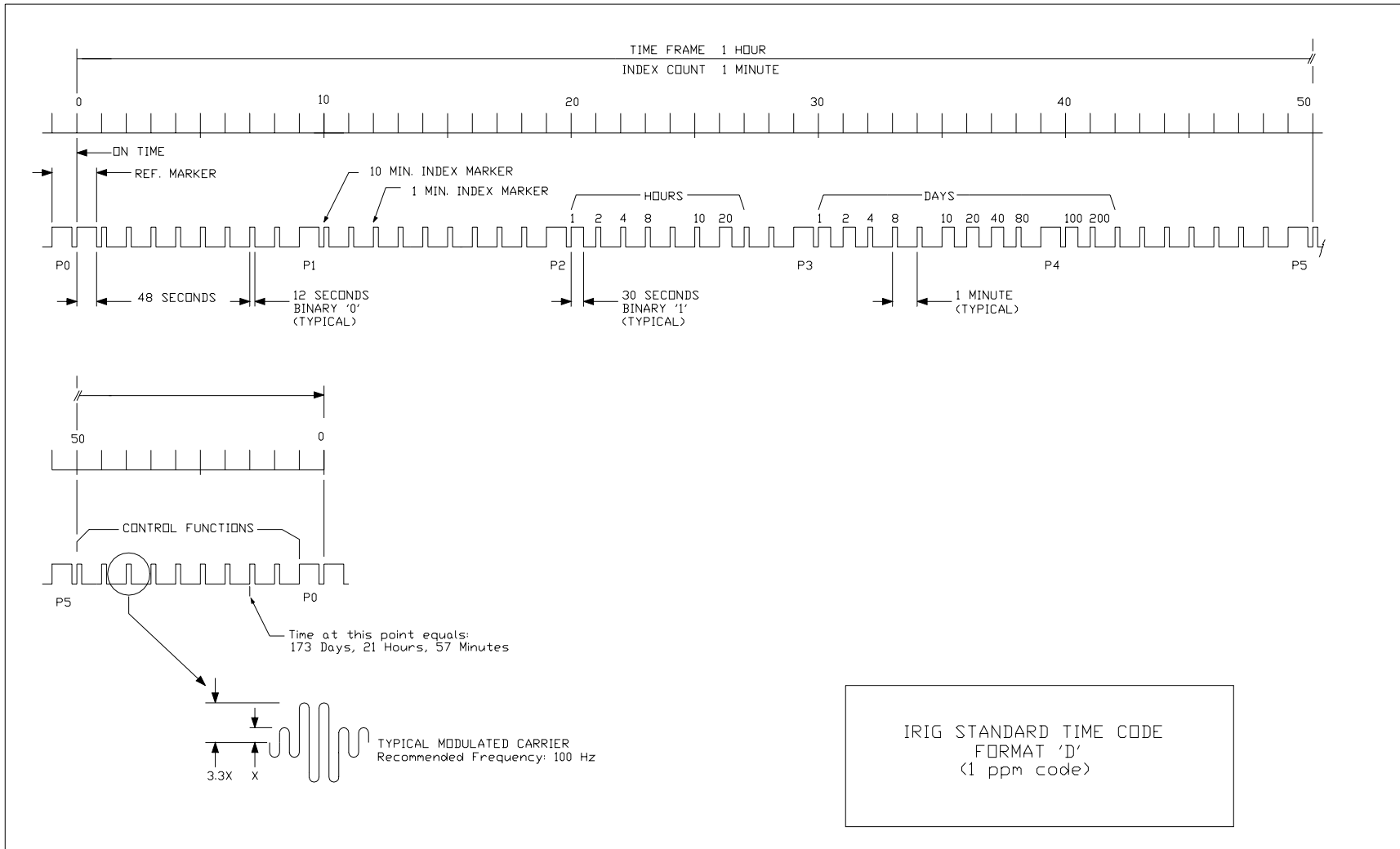

Figure 6-3. Format D: BCD time-of-year in days and hours and control bits.

TABLE 6-9. FORMAT D, SIGNAL D001

| BCD TIME-OF-YEAR CODE (16 DIGITS) | | | | | | | | | | | | | | |
|--|-----------------------------------|------------------------|--------------------|-----------------------------------|-------------------------|-----------------------------------|------------------------|-------------------------|-----------------------------------|-----------------------|-------------------------|-----------------------------------|-----------------------|-------------------------|
| MINUTES SUBWORD | | | | | HOURS SUBWORD | | | DAYS SUBWORD | | | | | | |
| BCD Code Digit No. | Subword Digit Wt MINUTES | BIT Time (Note 1) | BCD Code Digit No. | Subword Digit Wt MINUTES | BIT Time | BCD Code Digit No. | Subword Digit Wt HOURS | BIT Time | BCD Code Digit No. | Subword Digit Wt DAYS | BIT Time | BCD Code Digit No. | Subword Digit Wt DAYS | BIT Time |
| | Reference BIT | P _r | | Index Marker | P _r + 10 min | 1 | 1 | P _r + 20 min | 7 | 1 | P _r + 30 min | 15 | 100 | P _r + 40 min |
| | Index Marker | P _r + 1 min | | Index Marker | P _r + 11 min | 2 | 2 | P _r + 21 min | 8 | 2 | P _r + 31 min | 16 | 200 | P _r + 41 min |
| | Index Marker | P _r + 2 min | | Index Marker | P _r + 12 min | 3 | 4 | P _r + 22 min | 9 | 4 | P _r + 32 min | Index Marker | | P _r + 42 min |
| | Index Marker | P _r + 3 min | | Index Marker | P _r + 13 min | 4 | 8 | P _r + 23 min | 10 | 8 | P _r + 33 min | Index Marker | | P _r + 43 min |
| | Index Marker | P _r + 4 min | | Index Marker | P _r + 14 min | Index Marker | | P _r + 24 min | Index BIT | | P _r + 34 min | Index Marker | | P _r + 44 min |
| | Index Marker | P _r + 5 min | | Index Marker | P _r + 15 min | 5 | 10 | P _r + 25 min | 11 | 10 | P _r + 35 min | Index Marker | | P _r + 45 min |
| | Index Marker | P _r + 6 min | | Index Marker | P _r + 16 min | 6 | 20 | P _r + 26 min | 12 | 20 | P _r + 36 min | Index Marker | | P _r + 46 min |
| | Index Marker | P _r + 7 min | | Index Marker | P _r + 17 min | Index Marker | | P _r + 27 min | 13 | 40 | P _r + 37 min | Index Marker | | P _r + 47 min |
| | Index Marker | P _r + 8 min | | Index Marker | P _r + 18 min | Index Marker | | P _r + 28 min | 14 | 80 | P _r + 38 min | Index Marker | | P _r + 48 min |
| | Position Ident. (P ₁) | P _r + 9 min | | Position Ident. (P ₂) | P _r + 19 min | Position Ident. (P ₃) | | P _r + 29 min | Position Ident. (P ₄) | | P _r + 39 min | Position Ident. (P ₅) | | P _r + 49 min |

| CONTROL FUNCTIONS (9 BITS) | |
|---------------------------------------|-------------------------|
| Control Function BIT | BIT Time |
| 1 | P _r + 50 min |
| 2 | P _r + 51 min |
| 3 | P _r + 52 min |
| 4 | P _r + 53 min |
| 5 | P _r + 54 min |
| 6 | P _r + 55 min |
| 7 | P _r + 56 min |
| 8 | P _r + 57 min |
| 9 | P _r + 58 min |
| Position Ident. (P ₀) | P _r + 59 min |

Note: The BIT Time is the time of the BIT leading edge and refers to the leading edge of P_r.

TABLE 6-10. PARAMETERS FOR FORMAT D

| Pulse Rates | Pulse Duration |
|--|--|
| Bit rate: 1 ppm Position identifiers: 6 pph Reference mark: 1 pph | Index marker: 12 s Binary zero or unencoded bit: 12 s Binary one or coded bit: 30 s Position identifiers: 48 s Reference bit: 48 s |
| Resolution | Mark-To-Space Ratio |
| 1 m dc level 10 ms modulated 100 Hz carrier 1 ms modulated 1 kHz carrier | Nominal value of 10:1 Range of 3:1 to 6:1 |

6.5 Format E

6.5.1 The beginning of each 10 second time frame is identified by two consecutive 80 ms bits, P_0 and P_r . The leading edge of P_r is the on-time reference point for the succeeding time code. Position identifiers, P_0 and P_1 through P_9 , occur every 10th bit and 0.1 seconds before the leading edge of each succeeding 1 pps on-time bit (see Figure 6-4).

6.5.2 The time code word and control functions presented during the time frame are pulse width coded. The binary zero and index markers have duration of 20 ms, and the binary one has duration of 50 ms. The 10 pps leading edge is the on-time reference point for all bits.

6.5.3 The BCD time-of-year code word consists of 26 bits beginning at index count 6. The coded sub-word bits occur between position identifiers P_0 and P_5 : 3 for seconds, 7 for minutes, 6 for hours, and 10 for days. Nine bits for year information occur between position identifiers P_5 and P_6 to complete the BCD time code word. An index marker occurs between the decimal digits in each sub-word to provide separation for visual resolution. The LSB occurs first. The code recycles yearly. Each bit position is identified in Table 6-11.

6.5.4 Forty-five control functions occur between position identifiers P_6 and P_0 . Any control function bit or combination of bits can be programmed to read a binary one or zero during any specified number of time frames.

6.5.5 Control bit assignments, functions, and parameters for time code format E are shown on the following pages as:

Table 6-12: IRIG-E control bit assignment for year information

Table 6-13: Format E control functions (45 bits)

Table 6-14: Parameters for format E

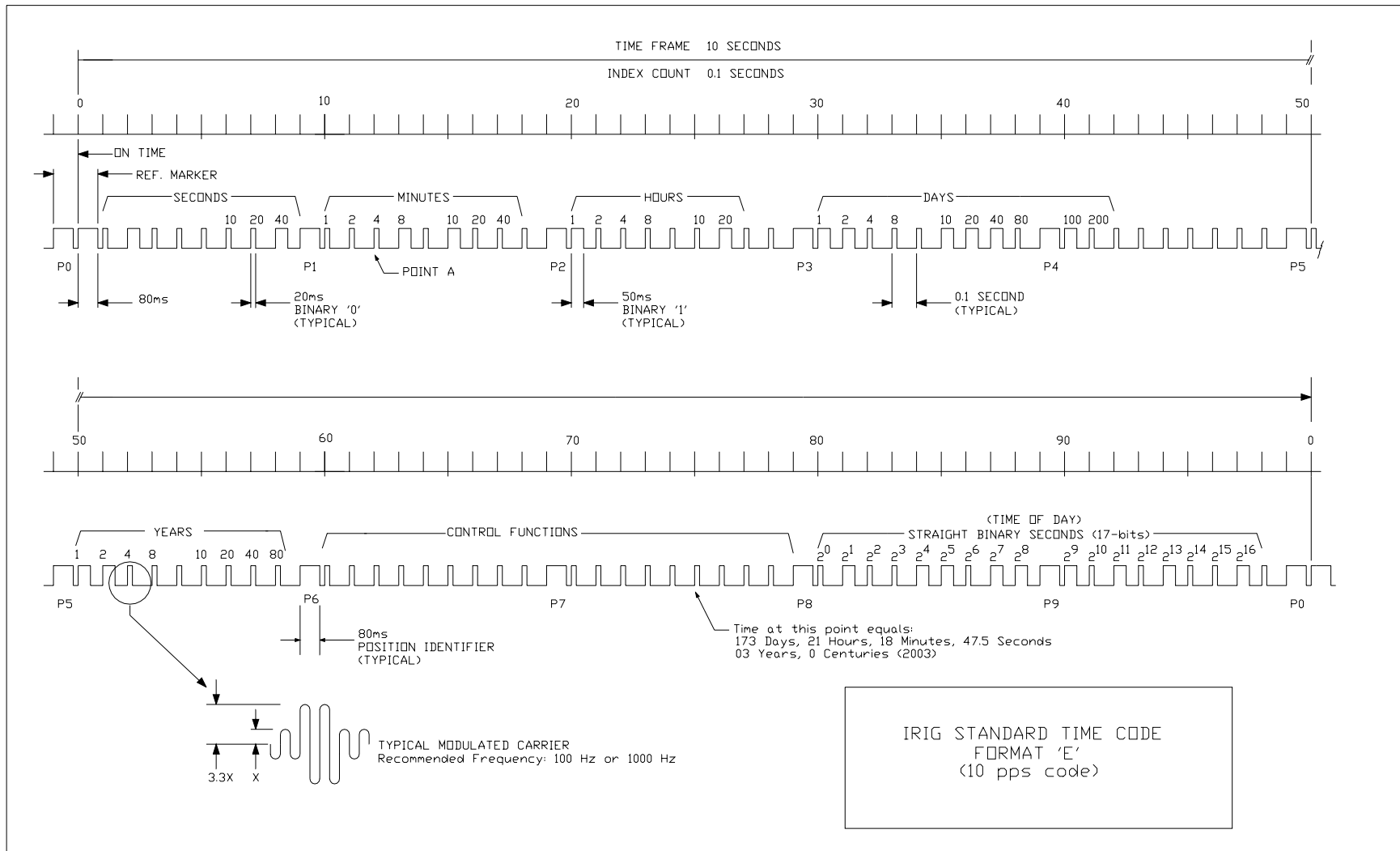

Figure 6-4. Format E: BCD time-of-year in days, hours, minutes, seconds, and year and control bits.

TABLE 6-11. FORMAT E, SIGNAL E001

| BCD TIME-OF-YEAR CODE (26 DIGITS) | | | | | | | | | | | | | | |
|--|---------------------------------|--------------------------|-----------------------------------|---------------------------------|--------------------------|-----------------------------------|-------------------------------|--------------------------|-----------------------------------|------------------------------|--------------------------|-----------------------------------|------------------------------|--------------------------|
| SECONDS SUBWORD | | | MINUTES SUBWORD | | | HOURS SUBWORD | | | DAYS SUBWORD | | | | | |
| BCD Code Digit No. | Subword Digit Wt SECONDS | BIT Time (Note 1) | BCD Code Digit No. | Subword Digit Wt MINUTES | BIT Time | BCD Code Digit No. | Subword Digit Wt HOURS | BIT Time | BCD Code Digit No. | Subword Digit Wt DAYS | BIT Time | BCD Code Digit No. | Subword Digit Wt DAYS | BIT Time |
| Reference BIT | | P _r | 4 | 1 | P _r + 1.0 sec | 11 | 1 | P _r + 2.0 sec | 17 | 1 | P _r + 3.0 sec | 25 | 100 | P _r + 4.0 sec |
| Index Marker | | P _r + 0.1 sec | 5 | 2 | P _r + 1.1 sec | 12 | 2 | P _r + 2.1 sec | 18 | 2 | P _r + 3.1 sec | 26 | 200 | P _r + 4.1 sec |
| Index Marker | | P _r + 0.2 sec | 6 | 4 | P _r + 1.2 sec | 13 | 4 | P _r + 2.2 sec | 19 | 4 | P _r + 3.2 sec | Index Marker | | P _r + 4.2 sec |
| Index Marker | | P _r + 0.3 sec | 7 | 8 | P _r + 1.3 sec | 14 | 8 | P _r + 2.3 sec | 20 | 8 | P _r + 3.3 sec | Index Marker | | P _r + 4.3 sec |
| Index Marker | | P _r + 0.4 sec | Index Marker | | P _r + 1.4 sec | Index Marker | | P _r + 2.4 sec | Index Marker | | P _r + 3.4 sec | Index Marker | | P _r + 4.4 sec |
| Index Marker | | P _r + 0.5 sec | 8 | 10 | P _r + 1.5 sec | 15 | 10 | P _r + 2.5 sec | 21 | 10 | P _r + 3.5 sec | Index Marker | | P _r + 4.5 sec |
| 1 | 10 | P _r + 0.6 sec | 9 | 20 | P _r + 1.6 sec | 16 | 20 | P _r + 2.6 sec | 22 | 20 | P _r + 3.6 sec | Index Marker | | P _r + 4.6 sec |
| 2 | 20 | P _r + 0.7 sec | 10 | 40 | P _r + 1.7 sec | Index Marker | | P _r + 2.7 sec | 23 | 40 | P _r + 3.7 sec | Index Marker | | P _r + 4.7 sec |
| 3 | 40 | P _r + 0.8 sec | Index Marker | | P _r + 1.8 sec | Index Marker | | P _r + 2.8 sec | 24 | 80 | P _r + 3.8 sec | Index Marker | | P _r + 4.8 sec |
| Position Ident. (P ₁) | | P _r + 0.9 sec | Position Ident. (P ₂) | | P _r + 1.9 sec | Position Ident. (P ₃) | | P _r + 2.9 sec | Position Ident. (P ₄) | | P _r + 3.9 sec | Position Ident. (P ₅) | | P _r + 4.9 sec |

6-16

| CONTROL FUNCTIONS (45 BITS) | | | | | | | | | |
|------------------------------------|--------------------------|-----------------------------------|--------------------------|-----------------------------------|--------------------------|-----------------------------------|--------------------------|-----------------------------------|--------------------------|
| Control Function BIT | BIT Time | Control Function BIT | BIT Time | Control Function BIT | BIT Time | Control Function BIT | BIT Time | Control Function BIT | BIT Time |
| 1 | P _r + 5.0 sec | 10 | P _r + 6.0 sec | 19 | P _r + 7.0 sec | 28 | P _r + 8.0 sec | 37 | P _r + 9.0 sec |
| 2 | P _r + 5.1 sec | 11 | P _r + 6.1 sec | 20 | P _r + 7.1 sec | 29 | P _r + 8.1 sec | 38 | P _r + 9.1 sec |
| 4 | P _r + 5.2 sec | 12 | P _r + 6.2 sec | 21 | P _r + 7.2 sec | 30 | P _r + 8.2 sec | 39 | P _r + 9.2 sec |
| 3 | P _r + 5.3 sec | 13 | P _r + 6.3 sec | 22 | P _r + 7.3 sec | 31 | P _r + 8.3 sec | 40 | P _r + 9.3 sec |
| 5 | P _r + 5.4 sec | 14 | P _r + 6.4 sec | 23 | P _r + 7.4 sec | 32 | P _r + 8.4 sec | 41 | P _r + 9.4 sec |
| 6 | P _r + 5.5 sec | 15 | P _r + 6.5 sec | 24 | P _r + 7.5 sec | 33 | P _r + 8.5 sec | 42 | P _r + 9.5 sec |
| 7 | P _r + 5.6 sec | 16 | P _r + 6.6 sec | 25 | P _r + 7.6 sec | 34 | P _r + 8.6 sec | 43 | P _r + 9.6 sec |
| 8 | P _r + 5.7 sec | 17 | P _r + 6.7 sec | 26 | P _r + 7.7 sec | 35 | P _r + 8.7 sec | 44 | P _r + 9.7 sec |
| 9 | P _r + 5.8 sec | 18 | P _r + 6.8 sec | 27 | P _r + 7.8 sec | 36 | P _r + 8.8 sec | 45 | P _r + 9.8 sec |
| Position Ident. (P ₆) | P _r + 5.9 sec | Position Ident. (P ₇) | P _r + 6.9 sec | Position Ident. (P ₈) | P _r + 7.9 sec | Position Ident. (P ₉) | P _r + 8.9 sec | Position Ident. (P ₀) | P _r + 9.9 sec |

Note 1: The BIT Time is the time of the BIT leading edge and refers to the leading edge of Pr.

TABLE 6-12. IRIG-E CONTROL BIT ASSIGNMENT FOR YEAR INFORMATION

| POS. ID | CTRL BIT NO | DESIGNATION | EXPLANATION |
|---|-------------|--------------|------------------------------|
| P0 to P5 is BCD Time-of-Year in Seconds, Minutes, Hours and Days. | | | |
| P49 | -- | P5 | Position Identifier # 5 |
| P50 | 1 | Year, BCD 1 | Last 2 digits of year in BCD |
| P51 | 2 | Year, BCD 2 | IBID |
| P52 | 3 | Year, BCD 4 | IBID |
| P53 | 4 | Year, BCD 8 | IBID |
| P54 | 5 | Not Used | Unassigned |
| P55 | 6 | Year, BCD 10 | Last 2 digits of year in BCD |
| P56 | 7 | Year, BCD 20 | IBID |
| P57 | 8 | Year, BCD 40 | IBID |
| P58 | 9 | Year, BCD 80 | IBID |
| P59 | -- | P6 | Position Identifier # 6 |
| P60 | 10 | Not Used | Unassigned |
| P61 | 11 | IBID | IBID |
| P62 | 12 | IBID | IBID |
| P63 | 13 | IBID | IBID |
| P64 | 14 | IBID | IBID |
| P65 | 15 | IBID | IBID |
| P66 | 16 | IBID | IBID |
| P67 | 17 | IBID | IBID |
| P68 | 18 | IBID | IBID |
| P69 | -- | P7 | Position Identifier # 7 |
| P6 to P0 are Control Functions | | | |
| | | | |

TABLE 6-13. FORMAT E CONTROL FUNCTIONS (45 BITS)

| Control Function BIT | BIT Time | Control Function BIT | BIT Time | Control Function BIT | BIT Time |
|------------------------------|-------------------------------------|------------------------------|-----------------|------------------------------|-----------------|
| 1 | Units of Year 01 $P_r + 5.0$ sec | 10 | $P_r + 6.0$ sec | 19 | $P_r + 7.0$ sec |
| 2 | Units of Year 02 | 11 | $P_r + 6.1$ sec | 20 | $P_r + 7.1$ sec |
| 3 | Units of Year 03 | 12 | $P_r + 6.2$ sec | 21 | $P_r + 7.2$ sec |
| 4 | Units of Year 04 | 13 | $P_r + 6.3$ sec | 22 | $P_r + 7.3$ sec |
| 5 | $P_r + 5.4$ sec | 14 | $P_r + 6.4$ sec | 23 | $P_r + 7.4$ sec |
| 6 | Tens of Year 10 | 15 | $P_r + 6.5$ sec | 24 | $P_r + 7.5$ sec |
| 7 | Tens of Year 20 | 16 | $P_r + 6.6$ sec | 25 | $P_r + 7.6$ sec |
| 8 | Tens of Year 40 | 17 | $P_r + 6.7$ sec | 26 | $P_r + 7.7$ sec |
| 9 | Tens of Year 80 | 18 | $P_r + 6.8$ sec | 27 | $P_r + 7.8$ sec |
| Position Ident. (P_6) | $P_r + 5.9$ sec | Position Ident. (P_7) | $P_r + 6.9$ sec | Position Ident. (P_8) | $P_r + 7.9$ sec |
| Control Function BIT | BIT Time | Control Function BIT | BIT Time | Control Function BIT | BIT Time |
| 28 | $P_r + 8.0$ sec | 37 | $P_r + 9.0$ sec | BLANK | BLANK |
| 29 | $P_r + 8.1$ sec | 38 | $P_r + 9.1$ sec | | |
| 30 | $P_r + 8.2$ sec | 39 | $P_r + 9.2$ sec | | |
| 31 | $P_r + 8.3$ sec | 40 | $P_r + 9.3$ sec | | |
| 32 | $P_r + 8.4$ sec | 42 | $P_r + 9.4$ sec | | |
| 33 | $P_r + 8.5$ sec | 42 | $P_r + 9.5$ sec | | |
| 34 | $P_r + 8.6$ sec | 43 | $P_r + 9.6$ sec | | |
| 35 | $P_r + 8.7$ sec | 44 | $P_r + 9.7$ sec | | |
| 35 | $P_r + 8.8$ sec | 45 | $P_r + 9.8$ sec | | |
| Position Ident. (P_9) | $P_r + 8.9$ sec | Position Ident. (P_0) | $P_r + 9.9$ sec | | |

TABLE 6-14. PARAMETERS FOR FORMAT E

| Pulse Rates | Pulse Duration |
|---|--|
| Bit rate: 10 pps Position identifier: 1 pps Reference mark: 6 ppm | Index marker: 20 ms Binary zero or unencoded bit: 20 ms Binary one or coded bit: 50 ms Position identifier: 80 ms Reference bit: 80 ms |
| Resolution | Mark-To-Space Ratio |
| 0.1 s dc level 10 ms modulated 100 kHz carrier 1 ms modulated 1 kHz carrier | Nominal value of 10:3 Range of 3:1 to 6:1 |

6.6 Format G

6.6.1 The beginning of each 0.01-second time frame is identified by two consecutive 80 μ s bits, P_0 and P_r . The leading edge of P_r is the on-time reference point for the succeeding time code. Position identifiers, P_0 and P_1 through P_9 , occur every 10th bit, 0.1 ms before the leading edge of each succeeding 1 k pps on-time bit (see Figure [6-5](#)).

6.6.2 The time code word and the control functions presented during the time frame are pulse width coded. The binary zero and index markers have durations of 20 μ s, and the binary one has duration of 50 μ s. The 10 k pps leading edge is the on-time reference point for all bits.

6.6.3 The BCD time-of-year code word consists of 38 bits beginning at index count one. The sub-word bits occur between position identifiers P_0 and P_6 : 7 for seconds, 7 for minutes, 6 for hours, 10 for days, 4 for tenths of seconds, and 4 for hundredths of seconds. Nine bits for year information occur between position identifiers P_6 and P_7 to complete the BCD time code word. An index marker occurs between the decimal digits in each sub-word, except for fractional seconds, to provide visual separation. The LSB occurs first, except for the fractional second information that follows the day-of-year information. The code recycles yearly. Each bit position is identified in Table [6-15](#).

6.6.4 Twenty-seven control bits occur between position identifiers P_7 and P_0 . Any control function bit or combination of bits can be programmed to read a binary one or zero during any specified number of time frames. Each control bit position is identified in table 6.

6.6.5 Control bit assignments, functions, and parameters for time code format G are shown on the following pages as:

Table [6-16](#): IRIG-G control bit assignment for year information

Table [6-17](#): Format G control functions (36 BITS)

Table [6-18](#): Parameters for format G

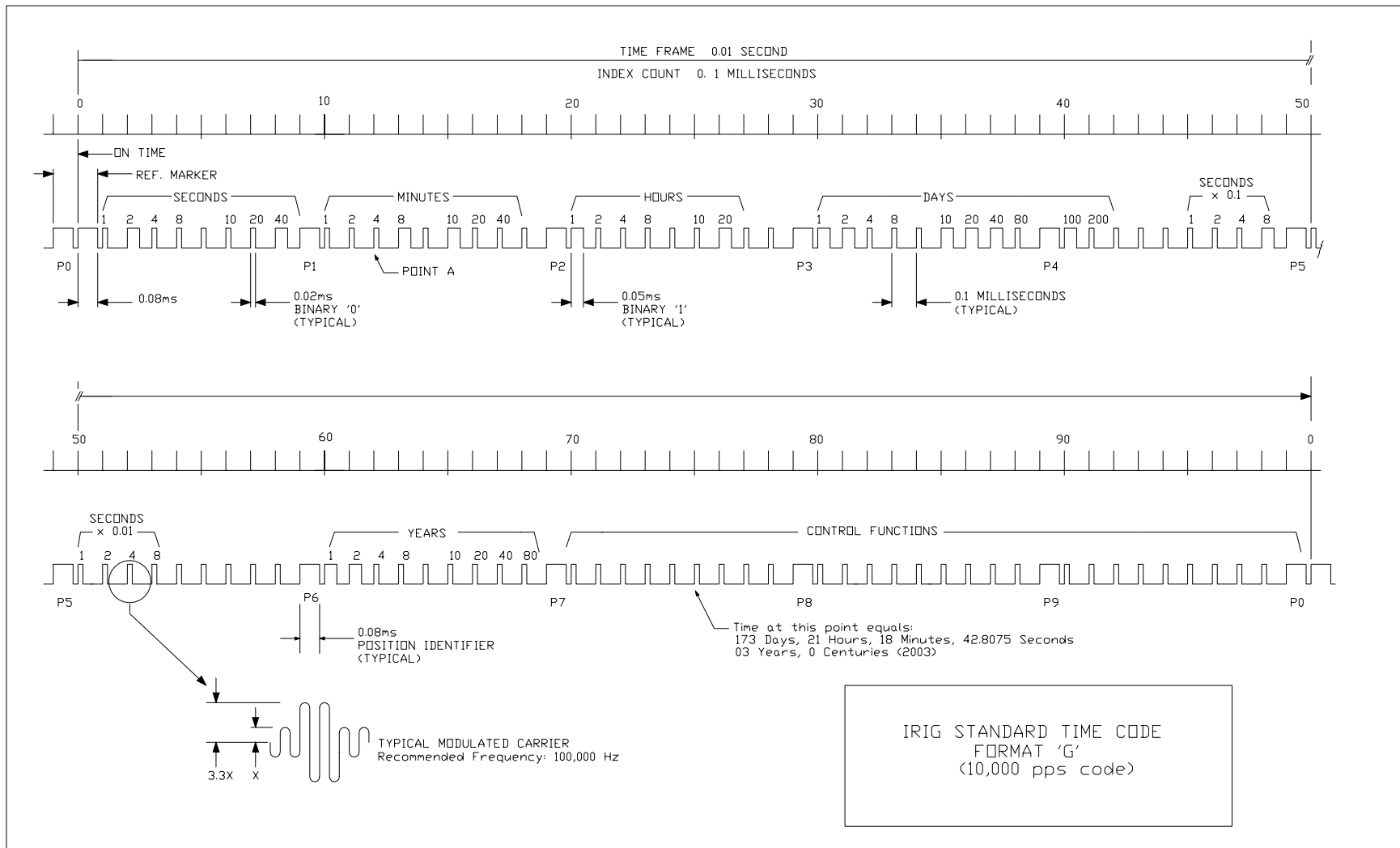

Figure 6-5. Format G: BCD Time-of-year in days, hours, minutes, seconds, and year and fractions-of-seconds, and control bits.

TABLE 6-15. FORMAT G, SIGNAL G001

| BCD TIME-OF-YEAR CODE (38 DIGITS) | | | | | | | | | | | | | | |
|-----------------------------------|--------------------------|-------------------|---------------------------|--------------------------|----------------|---------------------------|------------------------|----------------|------------------------------------|-----------------------|----------------|---------------------------|-----------------------|----------------|
| SECONDS SUBWORD | | | MINUTES SUBWORD | | | HOURS SUBWORD | | | DAYS AND FRACTIONAL SECOND SUBWORD | | | | | |
| BCD Code Digit No. | Subword Digit Wt SECONDS | BIT Time (Note 1) | BCD Code Digit No. | Subword Digit Wt MINUTES | BIT Time | BCD Code Digit No. | Subword Digit Wt HOURS | BIT Time | BCD Code Digit No. | Subword Digit Wt DAYS | BIT Time | BCD Code Digit No. | Subword Digit Wt DAYS | BIT Time |
| Reference BIT | | P_r | 8 | 1 | $P_r + 1.0$ ms | 15 | 1 | $P_r + 2.0$ ms | 21 | 1 | $P_r + 3.0$ ms | 29 | 100 | $P_r + 4.0$ ms |
| 1 | 1 | $P_r + 0.1$ ms | 9 | 2 | $P_r + 1.1$ ms | 16 | 2 | $P_r + 2.1$ ms | 22 | 2 | $P_r + 3.1$ ms | 30 | 200 | $P_r + 4.1$ ms |
| 2 | 2 | $P_r + 0.2$ ms | 10 | 4 | $P_r + 1.2$ ms | 17 | 4 | $P_r + 2.2$ ms | 23 | 4 | $P_r + 3.2$ ms | Index BIT | | $P_r + 4.2$ ms |
| 3 | 4 | $P_r + 0.3$ ms | 11 | 8 | $P_r + 1.3$ ms | 18 | 8 | $P_r + 2.3$ ms | 24 | 8 | $P_r + 3.3$ ms | Index BIT | | $P_r + 4.3$ ms |
| 4 | 8 | $P_r + 0.4$ ms | Index BIT | | $P_r + 1.4$ ms | Index BIT | | $P_r + 2.4$ ms | Index BIT | | $P_r + 3.4$ ms | Index BIT | | $P_r + 4.4$ ms |
| Index Bit | | $P_r + 0.5$ ms | 12 | 10 | $P_r + 1.5$ ms | 19 | 10 | $P_r + 2.5$ ms | 25 | 10 | $P_r + 3.5$ ms | 31 | 0.1 | $P_r + 4.5$ ms |
| 5 | 10 | $P_r + 0.6$ ms | 13 | 20 | $P_r + 1.6$ ms | 20 | 20 | $P_r + 2.6$ ms | 26 | 20 | $P_r + 3.6$ ms | 32 | 0.2 | $P_r + 4.6$ ms |
| 6 | 20 | $P_r + 0.7$ ms | 14 | 40 | $P_r + 1.7$ ms | Index BIT | | $P_r + 2.7$ ms | 27 | 40 | $P_r + 3.7$ ms | 33 | 0.4 | $P_r + 4.7$ ms |
| 7 | 40 | $P_r + 0.8$ ms | Index BIT | | $P_r + 1.8$ ms | Index BIT | | $P_r + 2.8$ ms | 28 | 80 | $P_r + 3.8$ ms | 34 | 0.8 | $P_r + 4.8$ ms |
| Position Ident. (P_1) | | $P_r + 0.9$ ms | Position Ident. (P_2) | | $P_r + 1.9$ ms | Position Ident. (P_3) | | $P_r + 2.9$ ms | Position Ident. (P_4) | | $P_r + 3.9$ ms | Position Ident. (P_5) | | $P_r + 4.9$ ms |

| BCD TIME-OF-YEAR CODE (Cont'd) | | |
|--------------------------------|--------------------------|----------------|
| FRACTIONAL SECOND SUB-WORD | | |
| BCD Code Digit No. | Subword Digit Wt SECONDS | BIT Time |
| 35 | 0.01 | $P_r + 5.0$ ms |
| 36 | 0.02 | $P_r + 5.1$ ms |
| 37 | 0.04 | $P_r + 5.2$ ms |
| 38 | 0.08 | $P_r + 5.3$ ms |
| Index BIT | | $P_r + 5.4$ ms |
| Index BIT | | $P_r + 5.5$ ms |
| Index BIT | | $P_r + 5.6$ ms |
| Index BIT | | $P_r + 5.7$ ms |
| Index BIT | | $P_r + 5.8$ ms |
| Position Ident. (P_6) | | $P_r + 5.9$ ms |

| YEAR AND CONTROL FUNCTIONS (36 BITS) | | | | | | | |
|--------------------------------------|---------------------------------|---------------------------|----------------|---------------------------|----------------|---------------------------|----------------|
| Control Function BIT | BIT Time | Control Function BIT | BIT Time | Control Function BIT | BIT Time | Control Function BIT | BIT Time |
| 1 | $P_r + 6.0$ ms Units of Year 01 | 10 | $P_r + 7.0$ ms | 19 | $P_r + 8.0$ ms | 28 | $P_r + 9.0$ ms |
| 2 | Units of Year 02 | 11 | $P_r + 7.1$ ms | 20 | $P_r + 8.1$ ms | 29 | $P_r + 9.1$ ms |
| 3 | Units of Year 04 | 12 | $P_r + 7.2$ ms | 21 | $P_r + 8.2$ ms | 30 | $P_r + 9.2$ ms |
| 4 | Units of Year 08 | 13 | $P_r + 7.3$ ms | 22 | $P_r + 8.3$ ms | 31 | $P_r + 9.3$ ms |
| 5 | $P_r + 6.4$ ms | 14 | $P_r + 7.4$ ms | 23 | $P_r + 8.4$ ms | 32 | $P_r + 9.4$ ms |
| 6 | Tens of Year 10 | 15 | $P_r + 7.5$ ms | 24 | $P_r + 8.5$ ms | 33 | $P_r + 9.5$ ms |
| 7 | Tens of Year 20 | 16 | $P_r + 7.6$ ms | 25 | $P_r + 8.6$ ms | 34 | $P_r + 9.6$ ms |
| 8 | Tens of Year 40 | 17 | $P_r + 7.7$ ms | 26 | $P_r + 8.7$ ms | 35 | $P_r + 9.7$ ms |
| 9 | Tens of Year 80 | 18 | $P_r + 7.8$ ms | 27 | $P_r + 8.8$ ms | 36 | $P_r + 9.8$ ms |
| Position Ident. (P_7) | $P_r + 6.9$ ms | Position Ident. (P_8) | $P_r + 7.9$ ms | Position Ident. (P_9) | $P_r + 8.9$ ms | Position Ident. (P_0) | $P_r + 9.9$ ms |

Note 1: The BIT Time is the time of the BIT leading edge and refers to the leading edge of P_r .

TABLE 6-16. IRIG-G CONTROL BIT ASSIGNMENT FOR YEAR INFORMATION

| POS. ID | CTRL BIT NO | DESIGNATION | EXPLANATION |
|---|-------------|--------------|------------------------------|
| P0 to P5 is BCD Time-of-Year in seconds, Minutes, Hours, Days and Fraction of seconds | | | |
| P49 | - | P6 | Position Identifier # 6 |
| P50 | 1 | Year, BCD 1 | Last 2 digits of year in BCD |
| P51 | 2 | Year, BCD 2 | IBID |
| P52 | 3 | Year, BCD 4 | IBID |
| P53 | 4 | Year, BCD 8 | IBID |
| P54 | 5 | Not Used | Unassigned |
| P55 | 6 | Year, BCD 10 | Last 2 digits of year in BCD |
| P56 | 7 | Year, BCD 20 | IBID |
| P57 | 8 | Year, BCD 40 | IBID |
| P58 | 9 | Year, BCD 80 | IBID |
| P59 | -- | P7 | Position Identifier # 7 |
| P60 | 10 | Not Used | Unassigned |
| P61 | 11 | IBID | IBID |
| P62 | 12 | IBID | IBID |
| P63 | 13 | IBID | IBID |
| P64 | 14 | IBID | IBID |
| P65 | 15 | IBID | IBID |
| P66 | 16 | IBID | IBID |
| P67 | 17 | IBID | IBID |
| P68 | 18 | IBID | IBID |
| P69 | -- | P8 | Position Identifier # 8 |
| P7 to P0 are control functions. | | | |
| Note 1: The bit Time is the time of the bit leading edge and refers to the leading edge of P _r | | | |

TABLE 6-17. FORMAT G CONTROL FUNCTIONS (36 BITS)

| Control Function BIT | BIT Time | Control Function BIT | BIT Time | Control Function BIT | BIT Time | Control Function BIT | BIT Time |
|---------------------------|------------------------------------|---------------------------|----------------|---------------------------|----------------|---------------------------|----------------|
| 1 | Units of Year 01 $P_r + 6.0$ ms | 10 | $P_r + 7.0$ ms | 19 | $P_r + 8.0$ ms | 28 | $P_r + 9.0$ ms |
| 2 | Units of Year 02 | 11 | $P_r + 7.1$ ms | 20 | $P_r + 8.1$ ms | 29 | $P_r + 9.1$ ms |
| 3 | Units of Year 04 | 12 | $P_r + 7.2$ ms | 21 | $P_r + 8.2$ ms | 30 | $P_r + 9.2$ ms |
| 4 | Units of Year 08 | 13 | $P_r + 7.3$ ms | 22 | $P_r + 8.3$ ms | 31 | $P_r + 9.3$ ms |
| 5 | $P_r + 6.4$ ms | 14 | $P_r + 7.4$ ms | 23 | $P_r + 8.4$ ms | 32 | $P_r + 9.4$ ms |
| 6 | Tens of Year 10 | 15 | $P_r + 7.5$ ms | 24 | $P_r + 8.5$ ms | 33 | $P_r + 9.5$ ms |
| 7 | Tens of Year 20 | 16 | $P_r + 7.6$ ms | 25 | $P_r + 8.6$ ms | 34 | $P_r + 9.6$ ms |
| 8 | Tens of Year 40 | 17 | $P_r + 7.7$ ms | 26 | $P_r + 8.7$ ms | 35 | $P_r + 9.7$ ms |
| 9 | Tens of Year 80 | 18 | $P_r + 7.8$ ms | 27 | $P_r + 8.8$ ms | 36 | $P_r + 9.8$ ms |
| Position Ident. (P_7) | $P_r + 6.9$ ms | Position Ident. (P_8) | $P_r + 7.9$ ms | Position Ident. (P_9) | $P_r + 8.9$ ms | Position Ident. (P_0) | $P_r + 9.9$ ms |

TABLE 6-18. PARAMETERS FOR FORMAT G

| Pulse Rates | Pulse Duration |
|---|--|
| Bit rate: 10 k pps Position identifier: 1 k pps Reference marker: 100 pps | Index marker: 20 μ s Binary zero or unencoded bit: 20 μ s Binary one or coded bit: 50 μ s Position identifiers: 80 μ s Reference bit: 80 μ s |
| Resolution | Mark-To-Space Ratio |
| 0.1 ms dc level 10 μ s modulated 100 Hz carrier | Nominal value of 10:3 Range of 3:1 to 6:1 |

6.7 Format H

6.7.1 The beginning of each 1-minute time frame is identified by two consecutive 0.8-second bits, P_0 and P_r . The leading edge of P_r is the on-time reference point for the succeeding time code. Position identifiers P_0 and P_1 through P_5 , occur every 10th bit one second before the leading edge of each succeeding 6 ppm on-time bit (see Figure [6-6](#)).

6.7.2 The time code word and the control functions presented during the time frame are pulse width coded. The binary zero and the index markers each have duration of 0.2 seconds, and a binary one has duration of 0.5 seconds. The leading edge is the 1 pps on-time reference point for all bits.

6.7.3 The BCD time-of-year consists of 23 bits beginning at index count 10. The sub-word bits occur between position identifiers P_0 and P_5 : 7 for minutes, 6 for hours, and 10 for days to complete the time code word. An index marker occurs between the decimal digits in each sub-word to provide separation for visual resolution. The LSB occurs first. The code recycles yearly. Each bit position is identified in Table [6-19](#).

6.7.4 Nine control functions occur between position identifiers P_5 and P_0 . Any control function bit or combination of bits can be programmed to read a binary one or zero during any specified number of time frames.

6.7.5 Details of the IRIG Format H parameters are shown at Table [6-20](#).

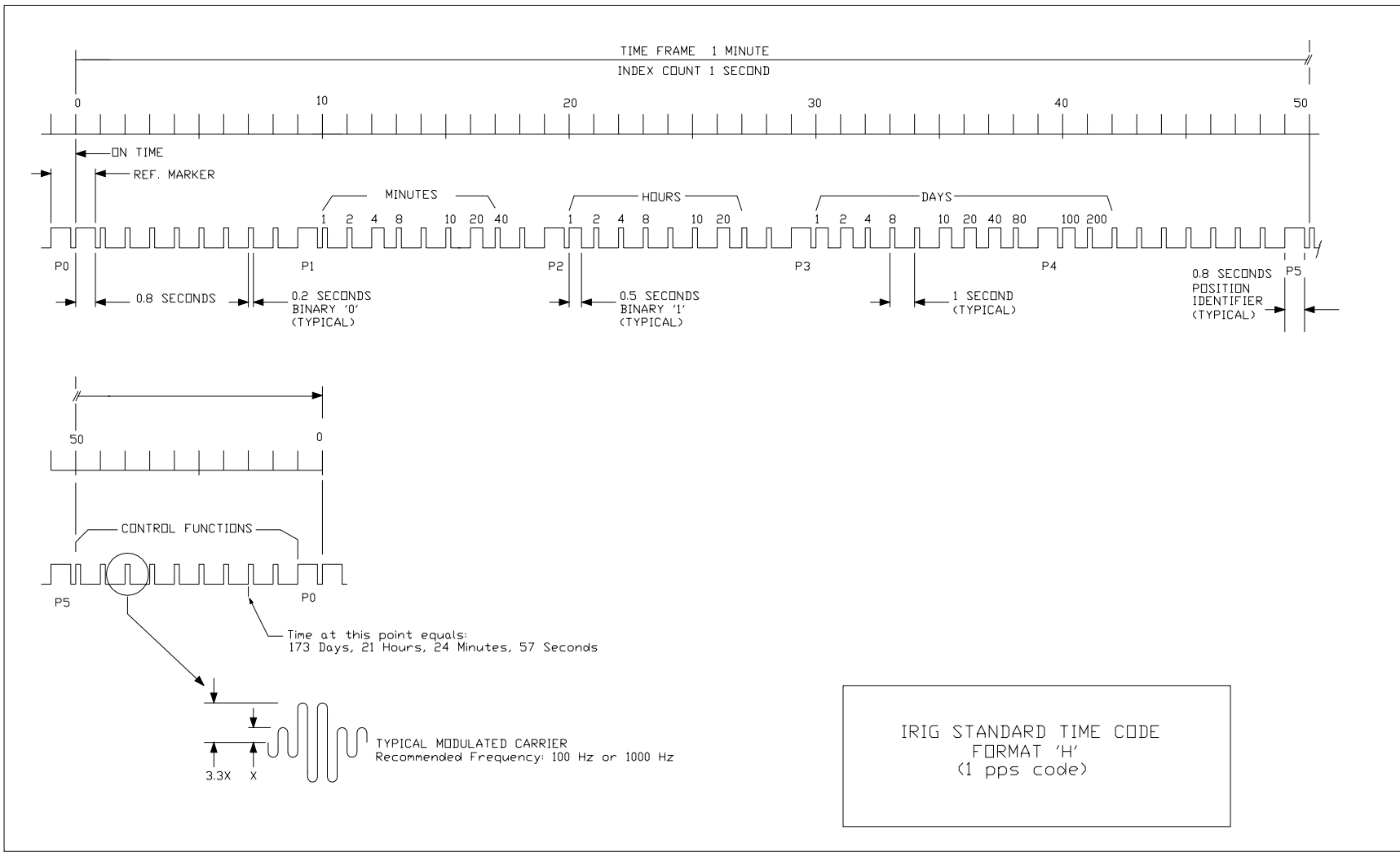

Figure 6-6. Format H: BCD time-of-year in days, hours, minutes, and control bits.

TABLE 6-19. FORMAT H, SIGNAL H001

| BCD TIME-OF-YEAR CODE (23 DIGITS) | | | | | | | | | | | | | | |
|--|--------------------------|------------------------|-----------------------------------|--------------------------|-------------------------|-----------------------------------|------------------------|-------------------------|-----------------------------------|-----------------------|-------------------------|-----------------------------------|-----------------------|-------------------------|
| | | | MINUTES SUBWORD | | | HOURS SUBWORD | | | DAYS SUBWORD | | | | | |
| BCD Code Digit No. | Subword Digit Wt SECONDS | BIT Time (Note 1) | BCD Code Digit No. | Subword Digit Wt MINUTES | BIT Time | BCD Code Digit No. | Subword Digit Wt HOURS | BIT Time | BCD Code Digit No. | Subword Digit Wt DAYS | BIT Time | BCD Code Digit No. | Subword Digit Wt DAYS | BIT Time |
| Reference BIT | | P _r | 1 | 1 | P _r + 10 sec | 8 | 1 | P _r + 20 sec | 14 | 1 | P _r + 30 sec | 22 | 100 | P _r + 40 sec |
| Index Marker | | P _r + 1 sec | 2 | 2 | P _r + 11 sec | 9 | 2 | P _r + 21 sec | 15 | 2 | P _r + 31 sec | 33 | 200 | P _r + 41 sec |
| Index Marker | | P _r + 2 sec | 3 | 4 | P _r + 12 sec | 10 | 4 | P _r + 22 sec | 16 | 4 | P _r + 32 sec | Index Marker | | P _r + 42 sec |
| Index Marker | | P _r + 3 sec | 4 | 8 | P _r + 13 sec | 11 | 8 | P _r + 23 sec | 17 | 8 | P _r + 33 sec | Index Marker | | P _r + 43 sec |
| Index Marker | | P _r + 4 sec | Index Marker | | P _r + 14 sec | Index Marker | | P _r + 24 sec | Index Marker | | P _r + 34 sec | Index Marker | | P _r + 44 sec |
| Index Marker | | P _r + 5 sec | 5 | 10 | P _r + 15 sec | 12 | 10 | P _r + 25 sec | 18 | 10 | P _r + 35 sec | Index Marker | | P _r + 45 sec |
| Index Marker | | P _r + 6 sec | 6 | 20 | P _r + 16 sec | 13 | 20 | P _r + 26 sec | 19 | 20 | P _r + 36 sec | Index Marker | | P _r + 46 sec |
| Index Marker | | P _r + 7 sec | 7 | 40 | P _r + 17 sec | Index Marker | | P _r + 27 sec | 20 | 40 | P _r + 37 sec | Index Marker | | P _r + 47 sec |
| Index Marker | | P _r + 8 sec | Index Marker | | P _r + 18 sec | Index Marker | | P _r + 28 sec | 21 | 80 | P _r + 38 sec | Index Marker | | P _r + 48 sec |
| Position Ident. (P ₁) | | P _r + 9 sec | Position Ident. (P ₂) | | P _r + 19 sec | Position Ident. (P ₃) | | P _r + 29 sec | Position Ident. (P ₄) | | P _r + 39 sec | Position Ident. (P ₅) | | P _r + 49 sec |

| CONTROL FUNCTIONS (9 BITS) | |
|-----------------------------------|-------------------------|
| Control Function BIT | BIT Time |
| 1 | P _r + 50 sec |
| 2 | P _r + 51 sec |
| 3 | P _r + 52 sec |
| 4 | P _r + 53 sec |
| 5 | P _r + 54 sec |
| 6 | P _r + 55 sec |
| 7 | P _r + 56 sec |
| 8 | P _r + 57 sec |
| 9 | P _r + 58 sec |
| Position Ident. (P ₀) | P _r + 59 sec |

Note 1: The BIT Time is the time of the BIT leading edge and refers to the leading edge of P_r.

TABLE 6-20. PARAMETERS FOR FORMAT H

| Pulse Rates | Pulse Duration |
|--|---|
| Bit rate: 1 pps Position identifier: 6 ppm Reference marker: 1 ppm | Index marker: 0.2 s Binary zero or unencoded bit: 0.2 s Binary one or coded bit: 0.5 s Position identifiers: 0.8 s Reference bit: 0.8 s |
| Resolution | Mark-To-Space Ratio |
| 1 s dc level 10 ms modulated 100 Hz carrier 1 ms modulated 1 kHz carrier | Nominal value of 10:3 Range of 3:1 to 6:1 |

This page intentionally left blank.

APPENDIX A

LEAP YEAR/LEAP SECOND CONVENTIONS

1.1 Leap Year Convention

The U.S. Naval Observatory Astronomical Applications Department defines the leap year according to the Gregorian calendar, which was instituted by Pope Gregory VIII in 1582 to keep the year in a cycle with the seasons. The average Gregorian calendar year, technically known as the Tropical Year, is approximately 365.2425 days in length and it will take about 3,326 years before the Gregorian calendar is as much as one day out of step with the seasons.

According to the Gregorian calendar, which is the civil calendar in use today, years that are evenly divisible by 4 are leap years with the exception of century years that are not evenly divisible by 400. This means that years 1700, 1800, 1900, 2100, 2200, and 2500 are NOT leap years and that years 1600, 2000, and 2400 ARE leap years.

Additional information can be found at the following U.S. Naval Observatory web sites.

- <http://timeanddate.com/date/leapyear.html>
- http://aa.usno.navy.mil/faq/docs/leap_years.html

1.2 Leap Second Convention

Civil time is occasionally adjusted by one-second increments to insure that the difference between a uniform time-scale defined by International Atomic Time (TAI) does not differ from the Earth's rotational time by more than 0.9 seconds. Consequently, Coordinated Universal Time (UTC), also an atomic time, was established in 1972 and is adjusted for the Earth's rotation and forms the basis for civil time.

Twenty two leap seconds have been added to keep UTC in synchronization with the rotation of the earth. In 1980, when the Global Positioning System (GPS) came into being, it was initially synchronized to UTC. However, GPS time does not add leap seconds, and consequently, GPS time is thirteen seconds ahead of UTC. The relationship between (TAI) and UTC is given by a simple accumulation of leap seconds occurring approximately once per year. If required, time changes are made on December 31 and on June 30 at 2400 hours.

At any instant (i), $T_i = \text{TAI time}$,

$U_i = \text{UTC time expressed in seconds, and}$

$T_i = U_i + L_i$

where (L_i) is the accumulated leap second additions between the epoch and the instant (i).

The U.S. Naval Observatory maintains a history of accumulated leap seconds on one of their web sites. The site URL is: <ftp://maia.usno.navy.mil/ser7/tai-utc.dat>, which provides a list of TAI minus UTC from 1961 to 1999. As of the publication date of this document, the last leap

second was in 1999. Additional information can be obtained from the U.S. Naval Observatory's Earth Orientation Department at the following web sites.

- <http://maia.usno.navy.mil/eo/leapsec.html>
- <http://tycho.usno.navy.mil/leapsec.990505.html>

APPENDIX B

BCD COUNT/BINARY COUNT

The reader is referred to Table B-1 for the BCD count data and Table [B-2](#) for Binary count Data.

| TABLE B-1. BCD COUNT (8n 4n 2n 1n) | | |
|---|----------------------|-----------------|
| Decimal Number | n | BCD Bits |
| 1 | 1 | 1 |
| 5 | 1 | 3 |
| 10 | 10 | 5 |
| 15 | 10 | 5 |
| 150 | 100 | 9 |
| 1 500 | 1×10^3 | 13 |
| 15 000 | 10×10^3 | 17 |
| 150 000 | 100×10^3 | 21 |
| 1 500 000 | 1×10^6 | 25 |
| 15 000 000 | 10×10^6 | 29 |
| 150 000 000 | 100×10^6 | 33 |
| 1 500 000 000 | 1×10^9 | 37 |
| 15 000 000 000 | 10×10^9 | 41 |
| 150 000 000 000 | 100×10^9 | 45 |
| 1 500 000 000 000 | 1×10^{12} | 49 |
| 15 000 000 000 000 | 10×10^{12} | 53 |
| 150 000 000 000 000 | 100×10^{12} | 57 |

TABLE B-2. BINARY COUNT (2ⁿ)

| Decimal Number | Binary Number | Decimal Number | Binary Number |
|-----------------------|----------------------|-----------------------|-----------------------|
| n | 2ⁿ | n | 2ⁿ |
| 0 | 1 | | |
| 1 | 2 | 26 | 67 108 864 |
| 2 | 4 | 27 | 134 217 728 |
| 3 | 8 | 28 | 268 435 456 |
| 4 | 16 | 29 | 536 870 912 |
| 5 | 32 | 30 | 1 073 741 824 |
| 6 | 64 | 31 | 2 147 483 648 |
| 7 | 128 | 32 | 4 294 967 296 |
| 8 | 256 | 33 | 8 589 934 592 |
| 9 | 512 | 34 | 17 179 869 184 |
| 10 | 1 024 | 35 | 34 359 738 368 |
| 11 | 2 048 | 36 | 68 719 476 736 |
| 12 | 4 096 | 37 | 137 438 953 472 |
| 13 | 8 192 | 38 | 274 877 906 944 |
| 14 | 16 384 | 39 | 54 9 755 813 888 |
| 15 | 32 768 | 40 | 1 099 511 627 776 |
| 16 | 65 536 | 41 | 2 199 023 255 552 |
| 17 | 131 072 | 42 | 4 398 046 511 104 |
| 18 | 262 144 | 43 | 8 796 093 022 208 |
| 19 | 524 288 | 44 | 17 592 186 044 416 |
| 20 | 1 048 576 | 45 | 35 184 372 088 832 |
| 21 | 2 097 152 | 46 | 70 368 744 177 664 |
| 22 | 4 194 304 | 47 | 140 737 488 355 328 |
| 23 | 8 388 608 | 48 | 281 474 976 710 656 |
| 24 | 16 777 216 | 49 | 562 949 953 421 312 |
| 25 | 33 554 432 | 50 | 1 125 899 906 842 620 |

APPENDIX C

HARDWARE DESIGN CONSIDERATIONS

| TABLE C-1. TIME CODE GENERATOR HARDWARE MINIMUM DESIGN CONSIDERATIONS | | | |
|--|---|--|---|
| Code | Level (dc) Pulse Rise Time Between the 10 and 90% Amplitude Points | Jitter Modulated at Carrier Frequency | Jitter Level (dc) Pulse-to-Pulse |
| Format A | ≤ 200 ns | $\leq 1\%$ | ≤ 100 ns |
| Format B | ≤ 1 μ s | $\leq 1\%$ | ≤ 200 ns |
| Format D | ≤ 1 μ s | $\leq 1\%$ | ≤ 200 ns |
| Format E | ≤ 1 μ s | $\leq 1\%$ | ≤ 200 ns |
| Format G | ≤ 20 ns | $\leq 1\%$ | ≤ 20 ns |
| Format H | ≤ 1 μ s | $\leq 1\%$ | ≤ 200 ns |

This page intentionally left blank

GLOSSARY

1.1 Definitions of Terms And Usage

Accuracy - Systematic uncertainty (deviation) of a measured value with respect to a standard reference.

Binary Coded Decimal (BCD) - A numbering system which uses decimal digits encoded in a binary representation ($1n\ 2n\ 4n\ 8n$) where $n=1, 10, 100, 1\ k, 10\ k\dots N$ (see appendix B).

Binary numbering system (Straight Binary) - A numbering system which has two as its base and uses two symbols, usually denoted by 0 and 1 (see appendix B).

BIT (B(INARY + DIG)IT) - An abbreviation of binary or binary-coded decimal digits which forms each sub-word and which determines the granularity or resolution of the time code word.

Frame rate - The repetition rate of the time code.

Index count - The number that identifies a specific bit position with respect to a reference marker.

Index markers - Uuencoded, periodic, interpolating bits in the time code.

Instrumentation Timing - A parameter serving as the fundamental variable in terms of which data may be correlated.

Leap second - See appendix A.

Leap year - See appendix A.

On-time - The state of any bit being coincident with a Standard Time Reference (U.S. Naval Observatory or National Bureau of Standards or other national laboratory).

On-time reference marker - The leading edge of the reference bit P_r of each time frame.

Position identifier - A particular bit denoting the position of a portion or all of a time code.

Precision - An agreement of measurement with respect to a defined value.

Reference marker - A periodic combination of bits, which establishes that instant of time, defined by the time code word.

Resolution (of a time code) - The smallest increment of time or least significant bit that can be defined by a time code word or sub-word.

Second - Basic unit of time or time interval in the International System of Units (SI) which is equal to 9 192 631 770 periods of radiation corresponding to the transition between the two hyperfine levels of the ground state of Cesium 133.

Subword - A subdivision of the time code word containing only one type of time unit, for example, days, hours, seconds or milliseconds.

Time - Signifies epoch, i.e., the designation of an instant of time on a selected time scale such as astronomical, atomic or UTC.

Time code -- A system of symbols used for identifying specific instants of time.

Time Code Word - A specific set of time code symbols that identifies one instant of time. A time code word may be subdivided into sub-words.

Time Frame - The time interval between consecutive reference markers that contains all the bits that determine the time code format.

Time Interval - The duration between two instants read on the same time scale, usually expressed in seconds or in a multiple or sub multiple of a second.

Time Reference - The basic repetition rate chosen as the common time reference for all instrumentation timing (usually 1 pps).

Time T_0 - The initial time $0^h 0^m 0^s$, January 1, or the beginning of an epoch.

1.2 Time-related terms and the relationship between the various time scales.

Coordinated Universal Time (UTC) - is maintained by the Bureau International de l'Heure (BIH) which forms the basis of a coordinated dissemination of standard frequencies and time signals. A UTC clock has the same rate as a TAI clock, but differs by an integral number of seconds. The step-time adjustments are called "leap seconds." Leap seconds are subtracted or added to UTC to keep in synchronism with UT1 to within ± 0.9 seconds (see appendix A).

DUT1 - is the predicted difference between UT1 and UTC and is given by $DUT1 = UT1 - UTC$.

Ephemeris Time (ET) - is obtained from observations of the motion of the moon about the earth.

Epoch - signifies the beginning of an event.

International Atomic Time (TAI) - is an atomic time scale based on data from a worldwide set of clocks and is the internationally agreed to time reference. The TAI is maintained by the BIH, Paris, France. Its epoch was set such that TAI was in approximate agreement with UT1 on 1 January 1958.

International Atomic Time (TAI) time code - represents a binary count of elapsed time in seconds since the 1 January 1958 epoch. The Bureau International de l'Heure (BIH), the U.S. Naval Observatory (USNO), and other national observatories and laboratories maintain this count which accumulates at 86,400 seconds per day.

Sidereal time - is determined and defined by observations of the earth with respect to the stars. A mean sidereal day is approximately $23^{\text{h}} 56^{\text{m}} 4.09^{\text{s}}$. A solar year contains 366.24 sidereal days.

Solar time - is based on the rotation of the earth about the sun.

Time scale - is a reference system for specifying occurrences with respect to time.

Universal time (UT) - is the mean solar time of the prime meridian plus 12h, determined by measuring the angular position of the earth about its axis. The UT is sometimes designated Greenwich Mean Time (GMT), but this designation should be avoided. The official U.S. Naval Observatory designation is UT(USNO)

UT0 - measures UT with respect to the observer's meridian (position on earth) that varies because of the conical motion of the poles.

UT1 - is UT0 corrected for variations in the polar motion and is proportional to the rotation of the earth in space. In its monthly bulletin, Circular-D, the Bureau International de l'Heure (BIH) publishes the current values of UT1 with respect to International Atomic Time (TAI).

UT2 - is UT1 corrected empirically for annual and semiannual variations of the rotation rate of the earth. The maximum correction is about 30 ms.