



WALWORTH®
Since 1842

IRON PLUG VALVES

CATALOG



INDEX

INTRODUCTION

ENGINEERING CONTROL.....	5
QUALITY SYSTEM	5
QUALITY CONTROL EQUIPMENT.....	9

SHORT, REGULAR & VENTURI PATTERN IRON PLUG VALVES

IRON PLUG VALVES.....	11
SHORT PATTERN IRON PLUG VALVES CLASS 200 CWP (SINGLE GLAND)	12
SHORT PATTERN IRON PLUG VALVES CLASS 200 CWP (REGULAR TYPE GLAND).....	15
REGULAR PATTERN IRON VALVES CLASS 200 CWP	20
VENTURI PATTERN IRON VALVES CLASS 175 CWP	25
VENTURI PATTERN IRON VALVES CLASS 500 CWP	28
PLUG VALVE WRENCHES	33
WALSEAL PLUG VALVES SEALANT	34
LUBRICANT ACCESORIES.....	36
PRESSURE-TEMPERATURE RATINGS	38
FLANGE DIMENSIONS AND TEMPLATES.....	39
DESIGN BASIS.....	40
HOW TO ORDER.....	41
GENERAL TERMS AND CONDITIONS	42



YARMOUTH RESEARCH AND TECHNOLOGY



WALWORTH

WALWORTH is one of the world's most comprehensive industrial valve manufacturers. Founded in 19th century by James WALWORTH, the Company has consistently dedicated itself to improvements in design and manufacturing of an array of valves exceptionally suited for the world's fluid control sector. We satisfy all end use industries and comprehensive customer requirements by adhering to the most demanding quality standards.

WALWORTH relies on its broad experience in supplying valves to the petrochemical, oil & gas, petroleum, power generation, pulp and paper, cryogenic and geothermal industries, among others.

Over the years, WALWORTH has produced over 40,000 different types of products and serves as a global supplier to various markets utilizing the expertise of over 500 trained employees.

Our manufacturing system includes: utilization of Company directed raw material warehouses; modern and newly acquired specialized machinery; welding processes such as SMAW, GMAW, SAW, PAW; assembly testing for all low pressure, high pressure, and at low or high temperatures; painting and coating processes; export crating and shipment.

WALWORTH is capable of providing the world's most comprehensive industrial valve line to the North American, Central American, South American, European and African markets. WALWORTH is proud to meet and satisfy the precise demands of our customers throughout the world by providing a quality product, competitive cost, and excellent service.



WALWORTH VALUES

MISSION

WALWORTH manufactures and supplies world-class valves and components for the flow control industry through exceptional service, competitive pricing, and consistently, on-time deliveries.



VISION

To be the world leader of unparalleled valve manufacturing and supply, WALWORTH:

- Set the standard for product quality in the flow control industry.
- Exceed the service expectations of our customers.
- Forge enduring relationships with customers, team members, and community.
- Hire, develop, and retain experienced and dedicated team members.



WALWORTH ENGINEERING CONTROL

WALWORTH products are manufactured following the strict international standards recognized all over the world, such as API, ANSI, ASME, ASTM, MSS, NACE, AWWA, BSI, CSA, among others. Our Engineering team consistently monitors updates to these standards and incorporates any applicable changes that affect the design, regulations and/or performance of our products.

Our designs are made using the most advanced technology and equipment, finite elements, and CAD system programs to ensure proper assembly and performance. From conception to calculation to detailed drawings for manufacturers, WALWORTH is a leader in development of new products that meet the needs of the current valve market.”



WALWORTH QUALITY SYSTEM

Throughout the years, WALWORTH has developed its Quality System which is an integral part of our manufacturing policy. Our primary goal is to provide products that meet and exceed market standards. In this sense, WALWORTH is an ISO-9001 Audited and Certified Company that has achieved major certifications worldwide. Our system includes the selection of raw materials from approved vendors, and rigorous oversight of our manufacturing process that is vital to quality control. The use of serial numbers allows WALWORTH the ability to not only ensure the quality of components used but to monitor and trace the fabrication process as well.

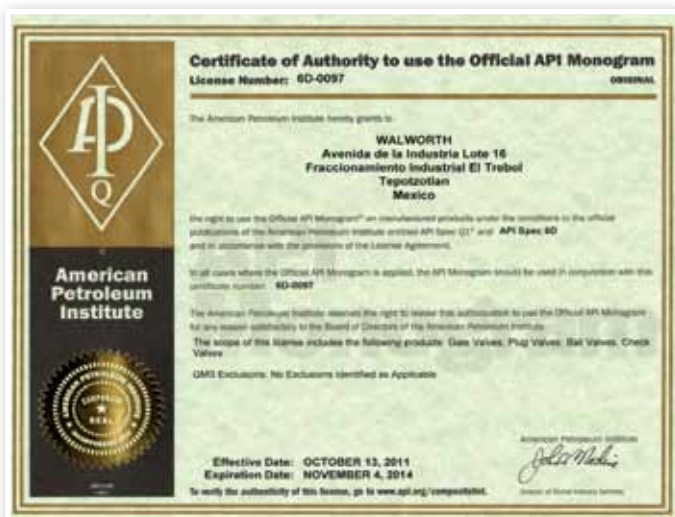

Certificate API-6D No. 6D-0097 issued by American Petroleum Institute to apply on Gate valves, Plug valves, Ball valves and Check valves manufactured in accordance with API-6D specification.



Certificate API-6A No. 6A-0234 from American Petroleum Institute to apply on valves at PSI, 1 through 4.



• Certificate ISO-9001 No. 038 issued by American Petroleum Institute since April 1999.



• Certificate as per PED 97/23/EC Module H to stamp CE products.



• Certificate of Reliable Supplier No. 082/11 issued by CFE in accordance with ISO-9001 Quality Assurance System.



• Certificate NMX-CC-9001 (Mexican Standards ISO-9001) No. 0552/2007 issued by PEMEX in accordance with ISO-9001 Quality Assurance System.

In addition to the quality system certifications, WALWORTH has been awarded with the following specific product certifications:



CERTIFICATE
 Certificate No.: 01 202 USA-TA-09-79708

Concerning the Agreement with the Technical Requirements in:
TA-Luft 2002, VDI 2440 Nov. 2000, Sec. 3.3.1.3

Test report: 209148 Datum: 03 December, 2004

Client: Industrial de Valvulas, S.A. de C.V.
 Manufacturer's Address: Av. De la Industria Lote 10
 Fracc. Industrial El Trebol,
 Tepotzotlan, Edo. De Mexico, CP 34800

The stem sealing system and internal flange connection have been successfully tested to meet the tightness criteria of $5 \cdot 10^{-7}$ mbar x l/(s x m) with a helium mass spectrometer under the following conditions. The SPV Valve with the examined mechanical shaft seals fulfills the requirements of Section 5.2.8.4 of The German Clean Air Act (TA-Luft), Leakage Verification) in accordance with Section 3.3.1.3 of VDI 2440 (Nov. 2000).

Kind of Valve:	Walworth API 600 Gate Valve	
Valve Type:	4 inch, Class 300, Figure 8285F	
Sealing System:	WCB Body / CR 13 Stem & Disc / HF Seat	
Sealing System:	Graphite Seals	
Nominal Size, Nominal Pressure:	4 inch, ANSI 300	
Inspection Media/Pressure:	Helium / 51 Bars	Temperature = Ambient
Switching Cycles (Shut):	9 Cycles	Total Cycles 900
Leakage Rate (mbar · l / sec):	8.2e-7 (mbar · l/sec)	2.7e-8 (mbar · l/sec)
Testing Method:	Helium Leak Test – VDI 2440, Appendix A	

Testing Laboratory:
 YARMOUTH RESEARCH AND TECHNOLOGY
 Matthew J. Wasielewski, PE
 434 Walnut Hill Road, N. Yarmouth, ME USA
 www.yarmouthresearch.com

TÜV Rheinland
 Industrial Service Division, Newtown, CT, USA
 Kazuo J. Sakata, Jr. – Examiner

- TA Luft Certificate (Fugitive Emission) Approval ISO-5211 Top Flange, Anti-Static Device.

YARMOUTH RESEARCH AND TECHNOLOGY

PROJECT SUMMARY

Project Number: 30003
 Customer: The Walworth Company
 Contact: David Cornelien
 Date(s) of Test: 12/9/99 – 12/20/99
 Product(s) Tested: One 4" Class 300 Gate Valve with Empak-Mex EAF-100-001 packing.

Purpose of Test: The test was conducted to evaluate the valve's stem sealing performance at ambient and at 350° F as related to the 1990 Amendments to the Clean Air Act requirements. Leakage measurements were conducted in accordance with 40 CFR Part 60, Appendix A, Method 21.

Conclusion: Three thermal cycles from ambient to 350 deg. F were conducted throughout 3500 open/close cycles with the valve pressurized to 645 psig. The valve was cycled with a 43 RPM gear motor coupled to the handwheel. One packing nut adjustment was required at cycle number 300 to maintain leakage levels below 100 PPMv.

At cycle number 3500, the packing leakage was 25-29 PPMv with the stem static. The packing nuts were tightened from 12/14 ft-lb back to 28 ft-lb and leakage decreased to about 1 PPMv.

See the attached data sheets for more information.

Test Witness:
 Matthew J. Wasielewski, P. E., President
 YARMOUTH RESEARCH AND TECHNOLOGY



Phone or Fax (207) 946-3006
 434 East Elm Street P.O. Box 519 Yarmouth, Maine 04096-0519

- Certificates of Ultra Low Fugitive Emissions No. 20985-3, 8 & 16 in accordance with ISO-15848-1 "Industrial Valves"-Measurement, Test and Qualification Procedures for Fugitive Emissions" "Part 1: Classification System and Qualification Procedures for Type Testing of Valves".

DACOR SERVICES
 CONSULTANTS
 ENGINEERING • QUALITY ASSURANCE • MANUFACTURING
 DAVID J. CORNELSEN, P.E., PRESIDENT

January 22, 2005

Ruben Parodes
 Walworth – Inval Facility
 Av. De la Industria Lote 16 Fracc. Industrial el Trebol
 Tepotzotlan, Edo. De Mexico
 CP 34600, Mexico

Reference: Witness Report – API Spec 6FA Fire Test
 Number 03-1 / 05

This will certify that the following listed valve successfully passed all requirements of API Specification 6FA Fire Test for Valves, Third Edition dated April 1999 and API Standard 607 Fire Test for Soft-Seated Quarter-Turn Valves, Fourth Edition dated May 1993. The tests were made and verified on January 21, 2005.

API 6D Trunion Mounted Ball Valve, 12-inch Class 150 Figure 8122, Serial Number V05B01.

The successful test of the 12-inch Class 150 API 6D Ball Valve qualifies this design/type of valve as meeting the requirements of API Spec 6FA / API Std 607 for sizes 12-inch through 24-inch in pressure classes 150 and 300.

Sincerely,

 David J. Cornelien P.E.
 President



24852 Mether Drive • Katy, Texas 77454
 TELEPHONE (281) 395-5071 • TELEFAX (281) 395-5013

- Fire Test Certificate No. 04/04 in accordance with API-6FA and API Standard API-607 for Trunion Ball Valves in accordance with API-6D.





Emissions after 500 cycles at ambient and 350 °F issued by Yarmouth Research and Technology Lab for 3 inch Class 300 Gate Valve After 500 cycles the measurement result was less than 50 ppm.

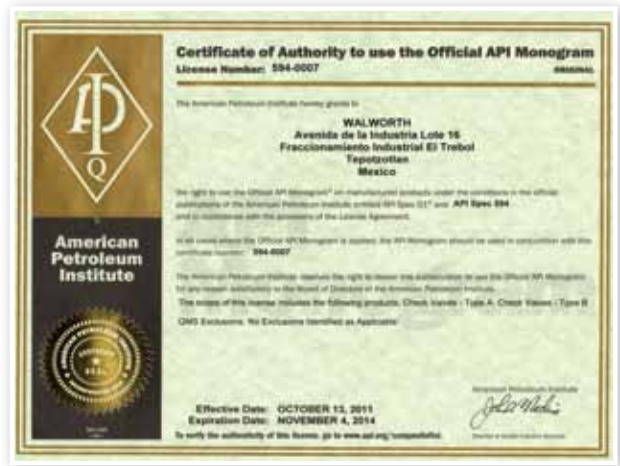

Certificate API-594 No. 594-0007 issued by American Petroleum Institute to apply on Check Valves-Type A; Check Valves Type B manufactured in accordance with API-594 specification.



Emissions after 500 cycles at ambient and 350 °F issued by Yarmouth Research and Technology Lab for 8 inch Class 300 Gate Valve After 500 cycles the measurement result was less than 50 ppm.



API-600 Certificate No. 600-0109 issued by American Petroleum Institute to apply on Bolted Bonnet Steel Gate Valves manufactured in accordance with API-600 specification.



Emissions after 500 cycles at ambient and 350 °F issued by Yarmouth Research and Technology Lab for 16 inch Class 150 Gate Valve After 500 cycles the measurement result was less than 50 ppm.



API-602 Certificate No. 602-0024 issued by American Petroleum Institute to apply on Compact Steel Gate Valves, Compact Steel Globe Valves, and Compact Steel Check Valves manufactured in accordance with API-602 specification.

QUALITY CONTROL EQUIPMENT

In order to assure that WALWORTH products comply with international quality standards, in-house equipment is kept for monitoring control. Some of this equipment includes:

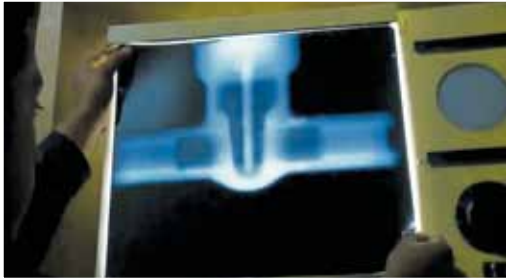

X-Ray Examination Equipment. WALWORTH has its own Ir-92 source in-house for the radiographic examination (RT) of castings from 0.100" up to 2 1/2" wall thickness to verify the soundness of the casting raw material.

PMI Equipment. A new generation of Positive Material Identification Equipment gives WALWORTH the capability to perform quick chemical analysis on incoming raw materials and on pieces after assembly, to certify that materials used were produced and assembled in accordance with WALWORTH's and our Customer's specifications.



Magnetic Particle Test. On a random basis for standard products or when a Customer requests MT Certification, WALWORTH has Magnetic Particle Test Equipment to perform on ferromagnetic materials.

Penetrant Test Examination. WALWORTH has the personnel and materials to perform PT examination by solvent removable or water washable techniques. NDT personnel are ASNT Certified.



Test Loop. A complete Laboratory Test loop exists for design validation of WALWORTH products. The test is performed at maximum design pressure, advances the valves from 3000 to 5000 cycles, and requires more than four months to complete.

Pressure Gradient Test Loop. This test exposes Plug valves to the extremes of both positive and negative pressure gradients to verify that the plug in a balanced plug design will prevent lock-up in the body.





Metrology Laboratory. WALWORTH developed a calibration and/or verification system in all of the equipment used in its facilities. This ensures our ability to trace measurements, control products, and comply with international standards.

Fire Test Facilities. WALWORTH has the facilities to perform fire tests in accordance with API requirements. The test exposes the valve to a fire flame at 1400 to 1800 °F (761 to 980 °C) to verify proper seal of the valve.



Low Fugitive Emissions Test. This test is performed when a Customer requires low fugitive emissions certification. Our Lab has its own LFE test equipment that is capable of measuring less than 20 ppm in both static and mechanical conditions at either ambient temperature or thermal cycle operations.

Ultrasonic Testing Equipment. Using ultrasonic techniques, we can detect sub surface flaws in materials and evaluate castings and forgings that cannot be radiographed. In addition, we utilize these techniques to measure the wall thickness of castings and forgings.



Tensile Test Equipment. We use this equipment to verify the mechanical properties of materials used for manufacturing. WALWORTH tests samples on a random basis even though we receive MTRs from our suppliers and foundries.

Hardness Test Equipments.- In both lab and shop tests, WALWORTH uses hardness tester equipment, such as Rockwell B, C Brinell or Vickers, to ensure compliance with specifications.



WALWORTH IRON PLUG VALVES

WALWORTH Cast Iron Lubricated Plug Valves are designed to meet the demand for an inexpensive product that incorporates the principal features of the Lubricated Plug Valves.

The Top Entry design is offered in three different patterns: Short, Regular and Venturi from 1/2" (12.7 mm) to 18" (450 mm) - Iron Body and Plug Classes 175, 200 & 500 CWP.

DESIGN FEATURES

- Design in accordance with API-599.
- Mechanical Balance spring to avoid jamming of the plug.
- Lever or gear operated.
- Bi-directional.
- Locking devices are available as an option
- Tamper proof bolting is available as an option
- Operating extensions and elevations.
- Additional Walseal sealants are available for different applications.
- Sealant Grooves. this system permits sealant injection while the valve is under full line pressure.

PRODUCT RANGE

PATTERN	SIZE	PRESSURE CLASS AS PER API	ENDS
Short	1/2" to 12"	200 CWP	Threaded or RF
Regular	1/2" to 12"	200 CWP	Threaded or RF
Venturi	14" to 18"	175 CWP	Threaded or RF
Venturi	6" to 8"	500 CWP	Threaded or RF



SHORT PATTERN

Provides face to face dimensions that match gate valves.



REGULAR PATTERN

Offers the largest port opening in a trapezoidal configuration – close to a full pipe size.



VENTURI PATTERN

Has a smaller port than the other two patterns. Is lower in cost and flow contours maximize hydraulic efficiency.

IRON PLUG VALVE SHORT PATTERN CLASS 200 CWP

Single Gland

DESIGN FEATURES

Short Pattern WALWORTH design offers big opening port and end to end dimensions same as a Gate Valve.

As in other types of WALWORTH Lubricated Plug Valves, the surfaces of the Single Gland Lubricated Plug Valve are “Pressure Sealed”. When the valve is in either the open or closed position, this seal is renewed by forcing lubricant under high pressure into a grooving system which completely encircles the ports.

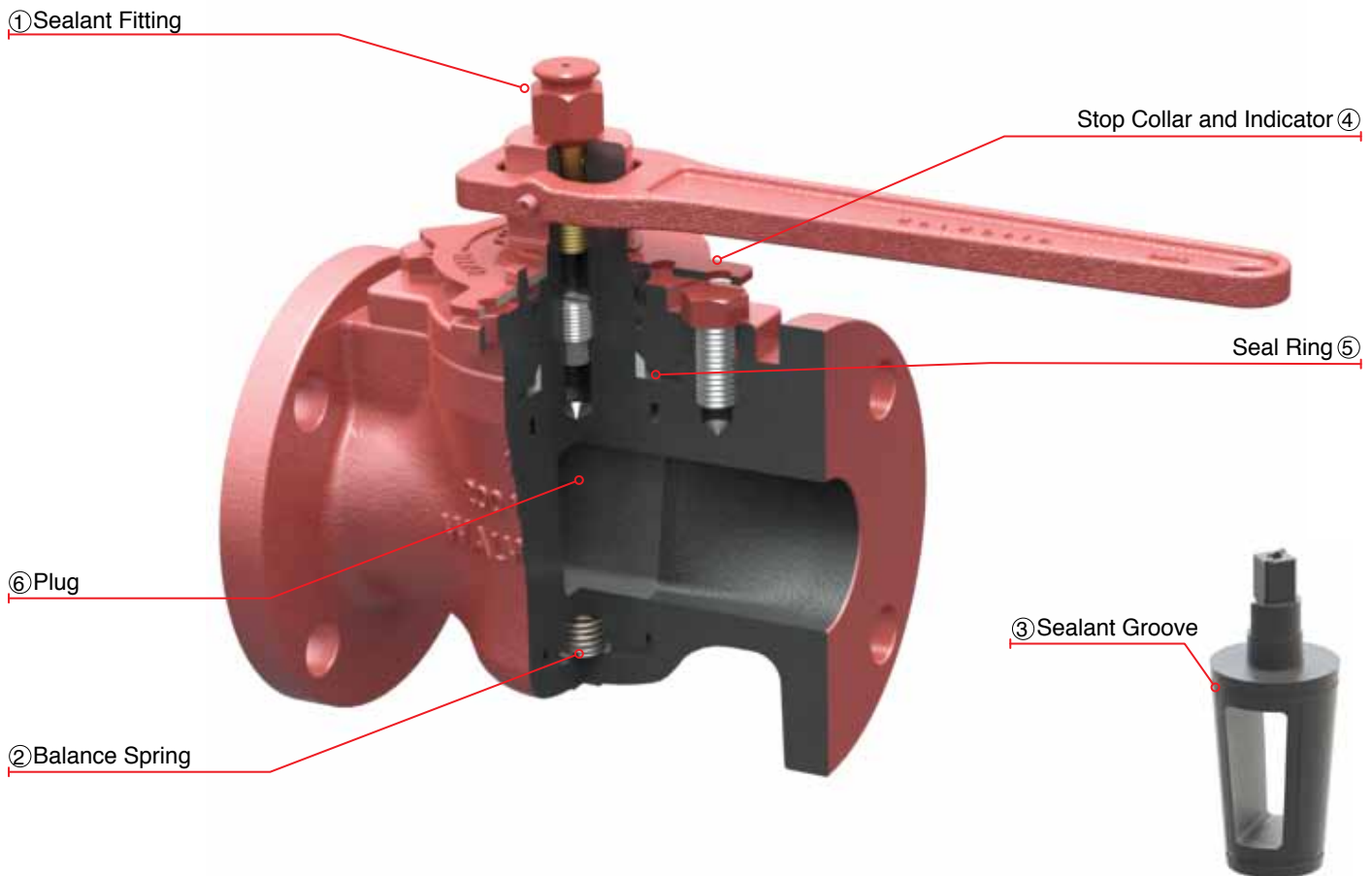

Design Features

- ① **Sealant Fitting.** Fast Sealant Injection that can be removed under pressure. The system includes Ball Check valves in order to prevent the back pressure and maintain the pressure in the sealant cavity.
- ② **Balancing Spring.** the mechanical spring type SS 304 is under compression and holds the plug in an equalized pressure position, thus eliminating the possibility of plug taper lock.
- ③ **Sealant Grooves.** this system permits sealant injection while the valve is under full line pressure. WALWORTH recommends to lubricate the valve with plug in the fully opened or fully closed position for optimum valve performance.
- ④ **Open/Closed Indicator.** quarter turn stop collar also functions as an indicator of the plug’s position.
- ⑤ **Diaphragm Gasket.** ensures a complete sealing of the valve against leakage.
- ⑥ **Plug.** WALWORTH Plugs are designed with an specific coating material that reduces the coefficient of friction making the valve to operate with low torque.

IRON PLUG VALVE SHORT PATTERN CLASS 200 CWP

Single Gland (Lever Operated)

Regular Bill of Materials

No.	Description	Material
1	BODY	ASTM A-126 CLASS B
2	GLAND	ASTM A-126 CLASS B
3	PLUG	ASTM A-126 CLASS B
4	STOP COLLAR	CARBON STEEL
5	GLAND SCREW	ASTM A 307 Gr. B
6	SEAL RING	REINFORCE TEFLON
7	GASKET	NITRILE BUTADIENE RUBBER
8	WEATHER SEAL	NITRILE BUTADIENE RUBBER
9	GREASE FITTING	COMMERCIAL STEEL
10	TRUARC RING	COMMERCIAL STEEL
11	BALANCE SPRING	STAINLESS STEEL
12	O-RING	NITRILE BUTADIENE RUBBER
13	SEALANT CHECK VALVE	COMMERCIAL STEEL
14	WRENCH	GRAY IRON
15	SET SCREW	ALLOY STEEL

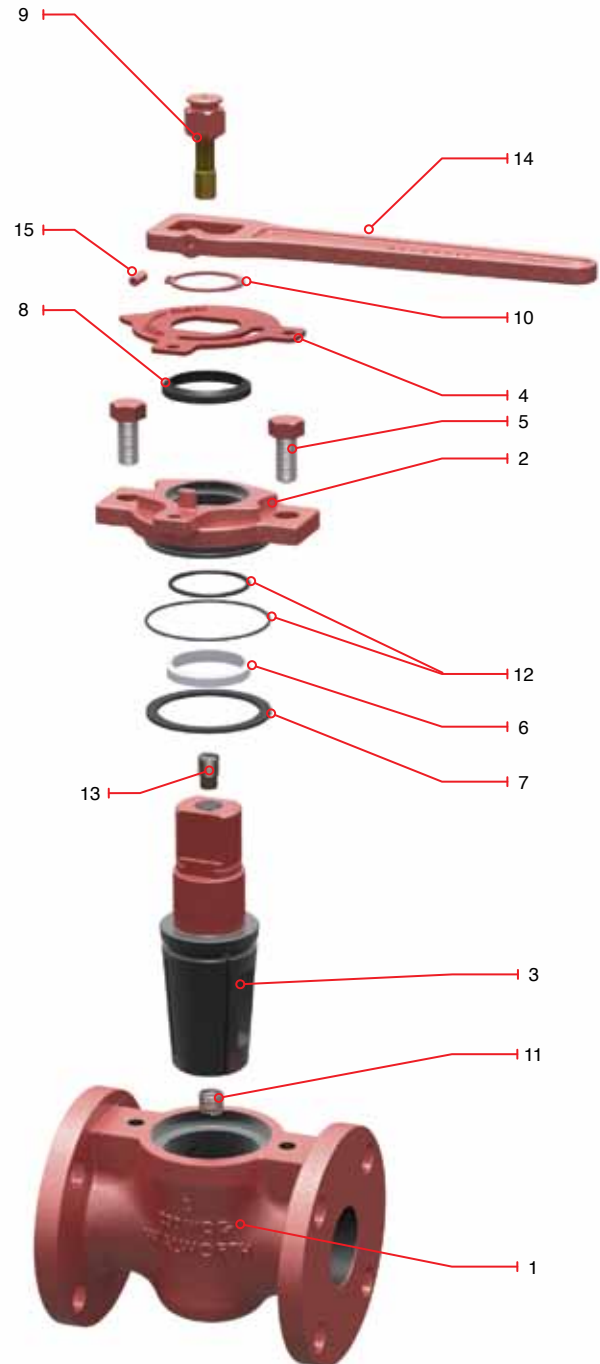

IRON PLUG VALVE SHORT PATTERN (1/2-5 NPS) CLASS 200 CWP

Single Gland Type (Lever Operated)

Design Features

- Threaded ends in accordance with ASME B1.20.1
- Flat Face Flanged ends in accordance with ASME B16.1
- Design in accordance with API 599
- Test in accordance with API 598 & MSS SP 78

Figure no.	Operation	Type of ends
1796	Lever operated	THREADED
1797F	Lever operated	FLANGED FLAT FACE

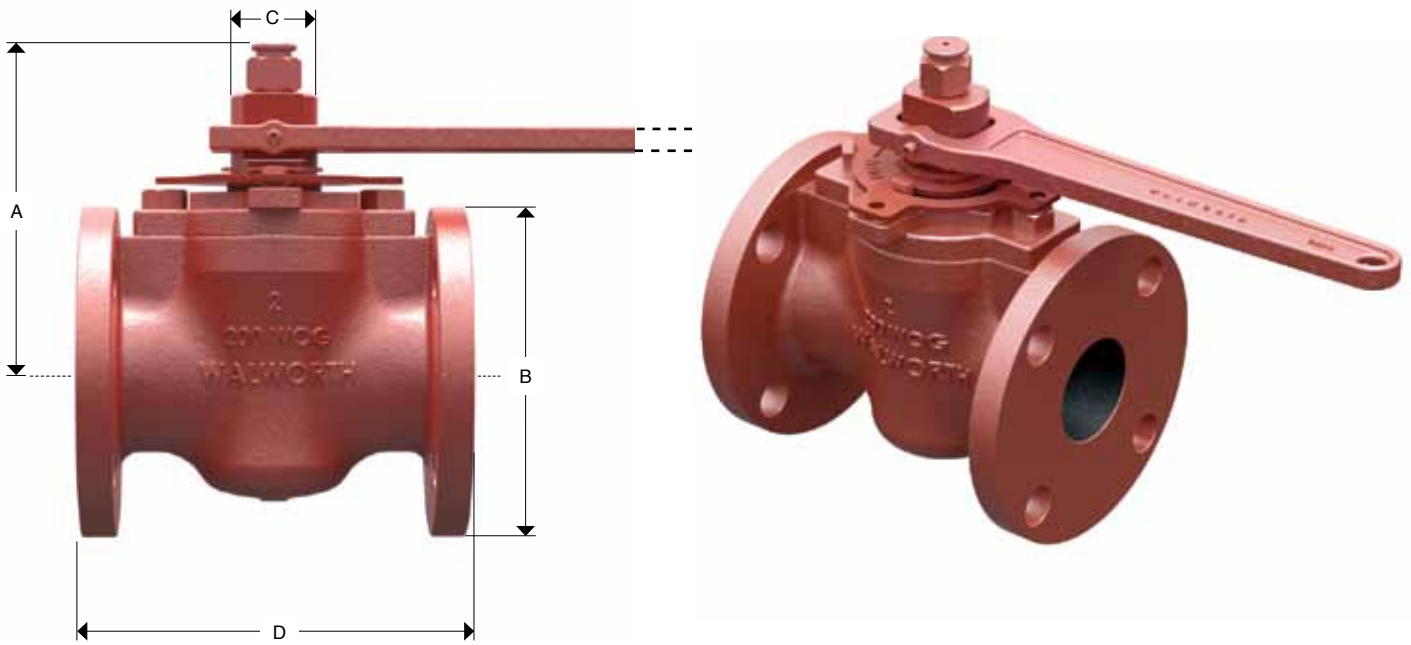

Dimensions and Weights

Nominal Size		A		B				C		End to End Dimensions				Approx. Weight				WRENCH	Operating NUT				
										D				FLAT FACE		THRD				FLAT FACE		THRD	
										FLAT FACE	THRD	FLAT FACE	THRD	FLAT FACE	THRD	FLAT FACE	THRD						
NPS	DN	in	mm	in	mm	in	mm	in	mm	in	mm	in	mm	lb	kg	lb	kg						
1/2	15	3.87	98	4.25	11	2.12	54	0.81	21	-	-	4.5	114	-	-	4.8	2.2	DB D-4	DB LN-1				
3/4	20	3.87	98	4.25	11	2.12	54	0.81	21	-	-	4.5	114	-	-	4.8	2.2	DB D-4	DB LN-1				
1	25	3.87	98	4.25	11	2.12	54	0.81	21	5.5	140	4.5	114	7.7	3.5	4.8	2.2	DB D-4	DB LN-1				
1 1/4	32	4.56	116	4.62	12	2.50	64	0.9	23	6.5	165	5	127	13	5.9	9.3	4.2	DB E-1	DB LN-2				
1 1/2	40	4.56	116	5	13	2.81	71	0.9	23	6.5	165	5	127	13.4	6.1	8.5	3.9	DB E-1	DB LN-2				
2	50	4.81	122	6	15	3.37	86	1.06	27	7	178	5.87	149	21.7	9.9	13.7	6.2	DB G-1	DB LN-3				
2 1/2	65	5.62	143	7	18	3.93	100	1.25	32	7.5	191	6.75	171	33.2	15.1	22.5	10.2	DB G-1	DB LN-3				
3	75	6.31	160	7.5	19	4.62	117	1.37	35	8	203	7.62	194	49	22.2	34.3	15.6	DB M-1	DB LN-5				
4	100	7.37	187	9	23	5.81	148	1.5	38	9	229	9	229	66	30	54	24.5	DB P-1	DB LN-6				
5	125	7.68	195	10	25	-	-	1.5	38	10	254	-	-	88	40	-	-	DB P-1.1	DB LN-6.1				

IRON PLUG VALVE SHORT PATTERN CLASS 200 CWP

Regular Gland Type

DESIGN FEATURES

WALWORTH Regular Gland type Lubricated Plug Valves are designed to control plug adjustment by thighten the gland nuts, requesting only a very low maintenance in the field.

These Valves are all provided with separate retainers (cover plate) and adjusting glands; generally sizes 3" and smaller have four-bolt square retainers, while 4 inches and large sizes have round retainers. They all incorporate the Pressure Sealed Lubrication features.

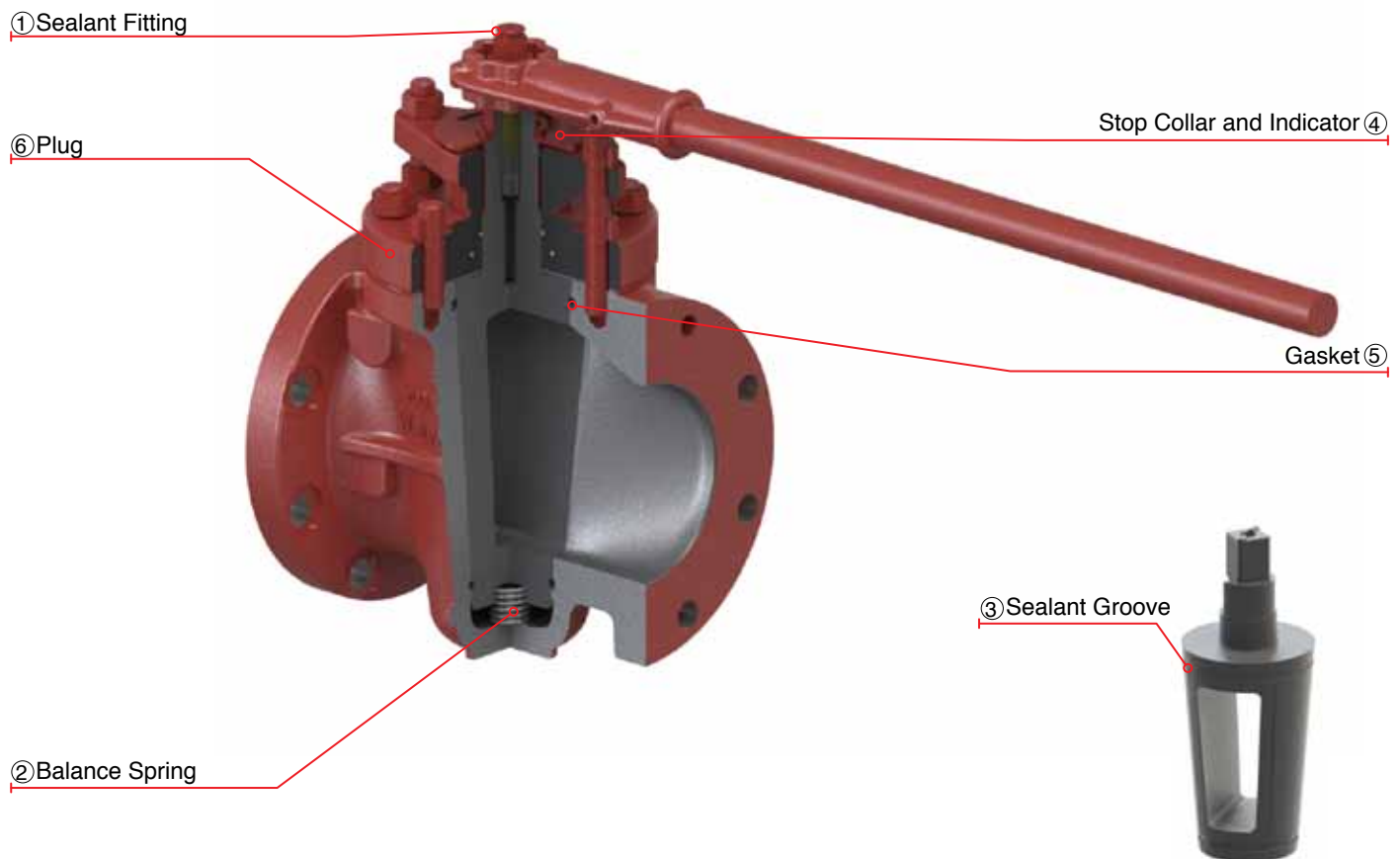

Design Features

- ① **Sealant Fitting.** Fast Sealant Injection that can be removed under pressure. The system includes Ball Check valves in order to prevent the back pressure and maintain the pressure in the sealant cavity.
- ② **Balancing Spring.** the mechanical spring type SS 304 is under compression and holds the plug in an equalized pressure position, thus eliminating the possibility of plug taper lock.
- ③ **Sealant Grooves.** this system permits sealant injection while the valve is under full line pressure. WALWORTH recommends that the valves be lubricated with plug in the fully opened or fully closed position for optimum valve performance.
- ④ **Open/Closed Indicator.** quarter turn stop collar also functions as an indicator of the plug's position.
- ⑤ **Diaphragm Gasket.** ensures a complete sealing of the valve against leakage.
- ⑥ **Plug.** WALWORTH Plugs are designed with an specific coating material that reduces the coefficient of friction making the valve to operate with low torque.

IRON PLUG VALVE SHORT PATTERN CLASS 200 CWP

Regular Gland Type (Lever Operated)

Regular Bill of Materials

No.	Description	Material
1	BODY	ASTM A-126 CLASS B
2	GLAND	ASTM A-126 CLASS B
3	PLUG	ASTM A-126 CLASS B
4	STOP COLLAR	CARBON STEEL
5	GLAND STUD	ASTM A 307 Gr. B
6	GLAND NUT	ASTM A 194 Gr. 2H
7	GASKET	STAINLESS STEEL + GRAPHITE
8	WEATHER SEAL	NITRILE BUTADIENE RUBBER
9	GREASE FITTING	COMMERCIAL STEEL
10	TRUARC RING	COMMERCIAL STEEL
11	BALANCE SPRING	STAINLESS STEEL
12	O-RING	NITRILE BUTADIENE RUBBER
13	SEALANT CHECK VALVE	COMMERCIAL STEEL
14	PLUG CHECK VALVE	COMMERCIAL STEEL
15	COVER STUD	ASTM A 307 GRADE B
16	COVER NUT	ASTM A 194 Gr. 2H
17	COVER	ASTM A-126 CLASE B
18	WRENCH	GRAY IRON
19	SET SCREW	ALLOY STEEL
20	WRENCH PIN	ASTM A568

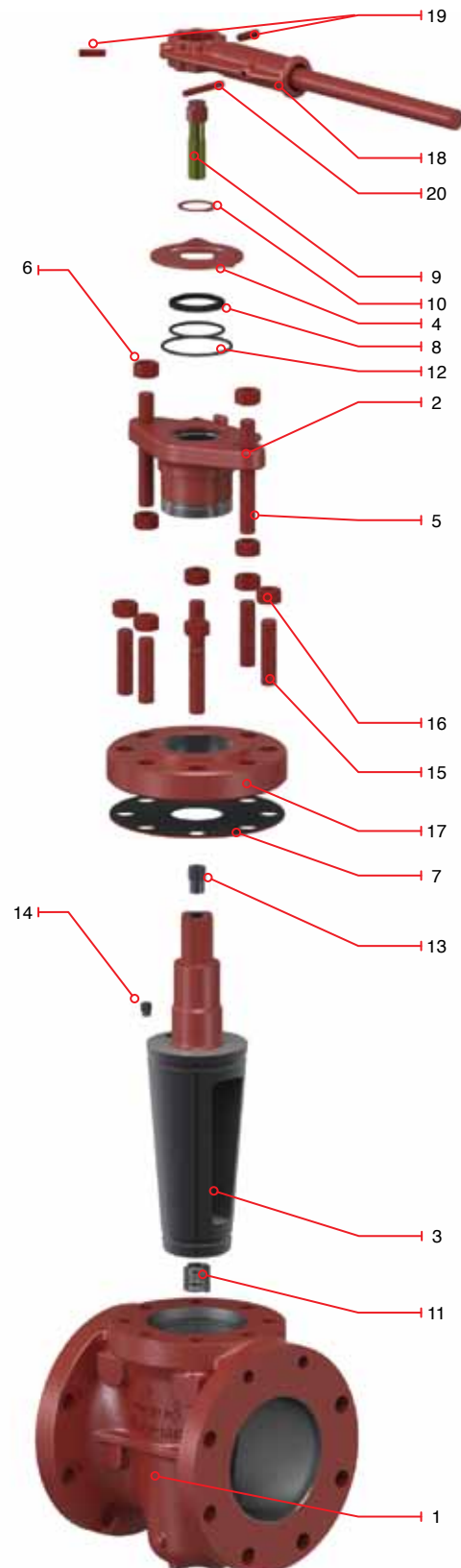

IRON PLUG VALVE SHORT PATTERN (6-12 NPS) CLASS 200 CWP (ANSI 150) Regular Gland Type (Lever Operated)

Design Features

- Flat Face Flanged ends in accordance with ASME B16.1
- Design in accordance with API 599
- Test in accordance with API 598 & MSS SP 78

Figure no.	Operation	Type of ends
1718F	Lever operated	FLANGED FLAT FACE

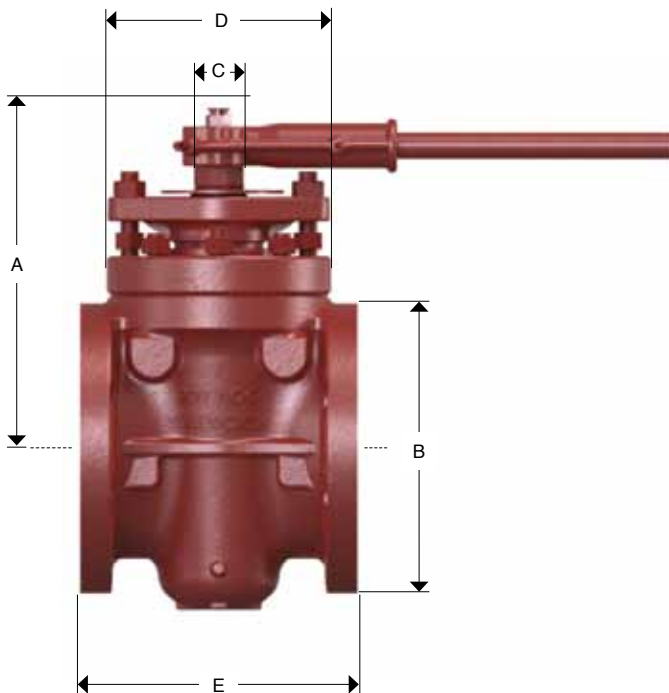

Dimensions and Weights

Nominal Size		General Dimensions								End to End Dimensions		Approx Weight		Wrench No.	Operating Nut
		A		B		C		D		E		FLAT FACE			
in	mm	in	mm	in	mm	in	mm	in	mm	in	mm	lb	kg		
6	150	11.75	298	11	279	1.5	38	8.37	213	10.5	267	154	69.9	P-1	LN-6
8	200	13.5	343	13.5	343	1.75	44	9.62	244	11.5	292	237	107.6	R-3	LN-7
10	250	14.5	368	16	406	2	51	10.87	276	13	330	334	151.6	T-3	-
12	300	18.18	462	19	483	2.43	62	13.5	343	14	356	580	263.3	V-3	-

IRON PLUG VALVE SHORT PATTERN CLASS 200 CWP (Gear Operated)

Regular Bill of Materials

No.	Description	Material
1	BODY	ASTM A-126 CLASS B
2	GLAND	ASTM A-126 CLASS B
3	PLUG	ASTM A-126 CLASS B
4	GLAND STUD	ASTM A 307 Gr. B
5	GLAND NUT	ASTM A 194 Gr. 2H
6	GASKET	STAINLESS STEEL + GRAPHITE
7	WEATHER SEAL	NITRILE BUTADIENE RUBBER
8	GREASE FITTING	COMMERCIAL STEEL
9	TRUARC RING	COMMERCIAL STEEL
10	BALANCE SPRING	STAINLESS STEEL
11	O-RING	NITRILE BUTADIENE RUBBER
12	SEALANT CHECK VALVE	COMMERCIAL STEEL
13	PLUG CHECK VALVE	COMMERCIAL STEEL
14	COVER STUD	ASTM A 307 GRADE B
15	COVER NUT	ASTM A 194 Gr. 2H
16	COVER	ASTM A-126 CLASE B
17	GEAR OPERATOR	COMERCIAL STEEL
18	GEAR OPERATOR SUPPORT	CARBON STEEL
19	GEAR OPERATOR BOLTING	ASTM A 307 Gr. B
20	STEM EXTENSION	ASTM A 322 GRADE 4140
21	STOP COLLAR	CARBON STEEL

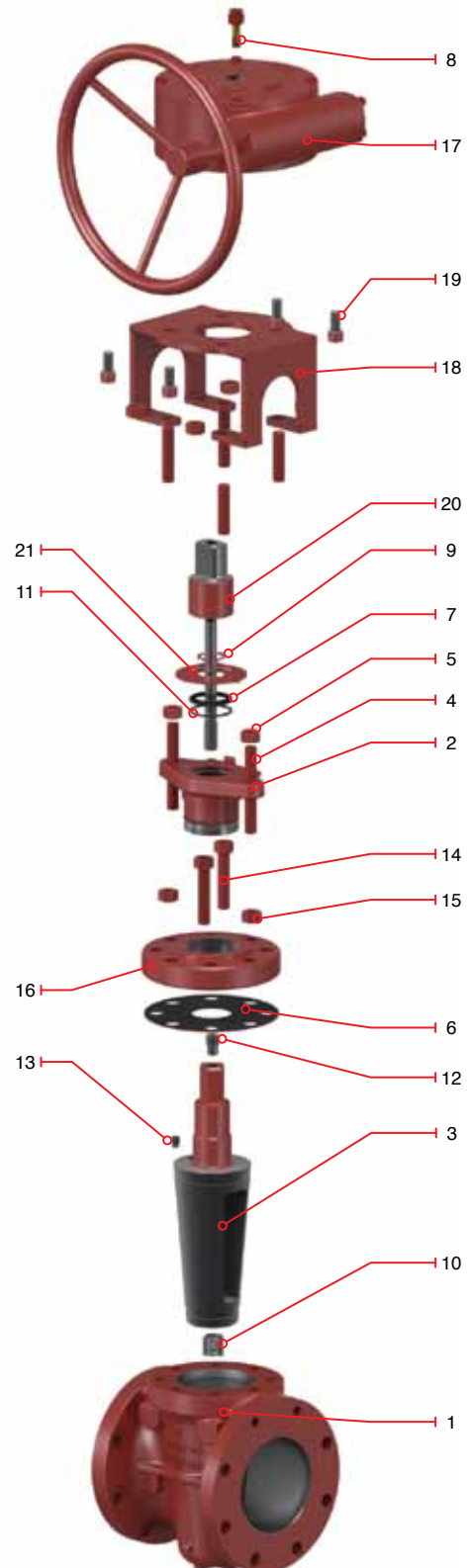

IRON PLUG VALVE SHORT PATTERN (6-12 NPS) CLASS 200 CWP (Gear Operated)

Design Features

- Flat Face Flanged ends in accordance with ASME B16.1
- Design in accordance with API 599
- Test in accordance with API 598 & MSS SP 78

Figure no.	Operation	Type of ends
1727F	Gear Operated	FLANGED FLAT FACE

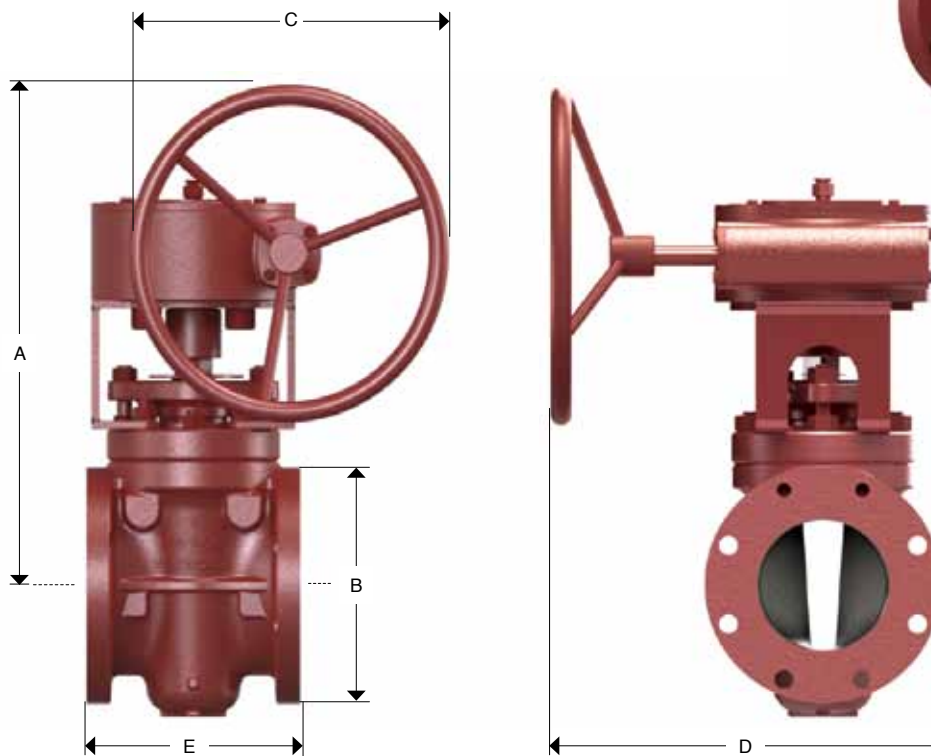

Dimensions and Weights

Nominal Size		General Dimensions								End to End Dimensions		Approx Weight	
		A		B		C		D (approx)		E		FLAT FACE	
in	mm	in	mm	in	mm	in	mm	in	mm	in	mm	lb	kg
6	150	18.68	474	11	279	23	584	18	457	10.5	267	220	99.9
8	200	18	457	13.5	343	23	584	21	533	11.5	292	290	131.7
10	250	20.06	510	16	406	23	584	27	685	13	330	450	204.3
12	300	22.68	576	19	483	23	584	31	787	14	356	685	311

IRON PLUG VALVE REGULAR PATTERN CLASS 200 CWP

Regular Gland Type (Lever Operated)

DESIGN FEATURES

WALWORTH Regular Pattern Plug Valve provide largest port opening in a trapezoidal configuration with the close dimensions to a full pipe size.

These Valves are all provided with separate retainers (cover plate) and adjusting glands; generally sizes 3" and smaller have four-bolt square retainers, while 4 inches and large sizes have round retainers. They all incorporate the Pressure Sealed Lubrication features.

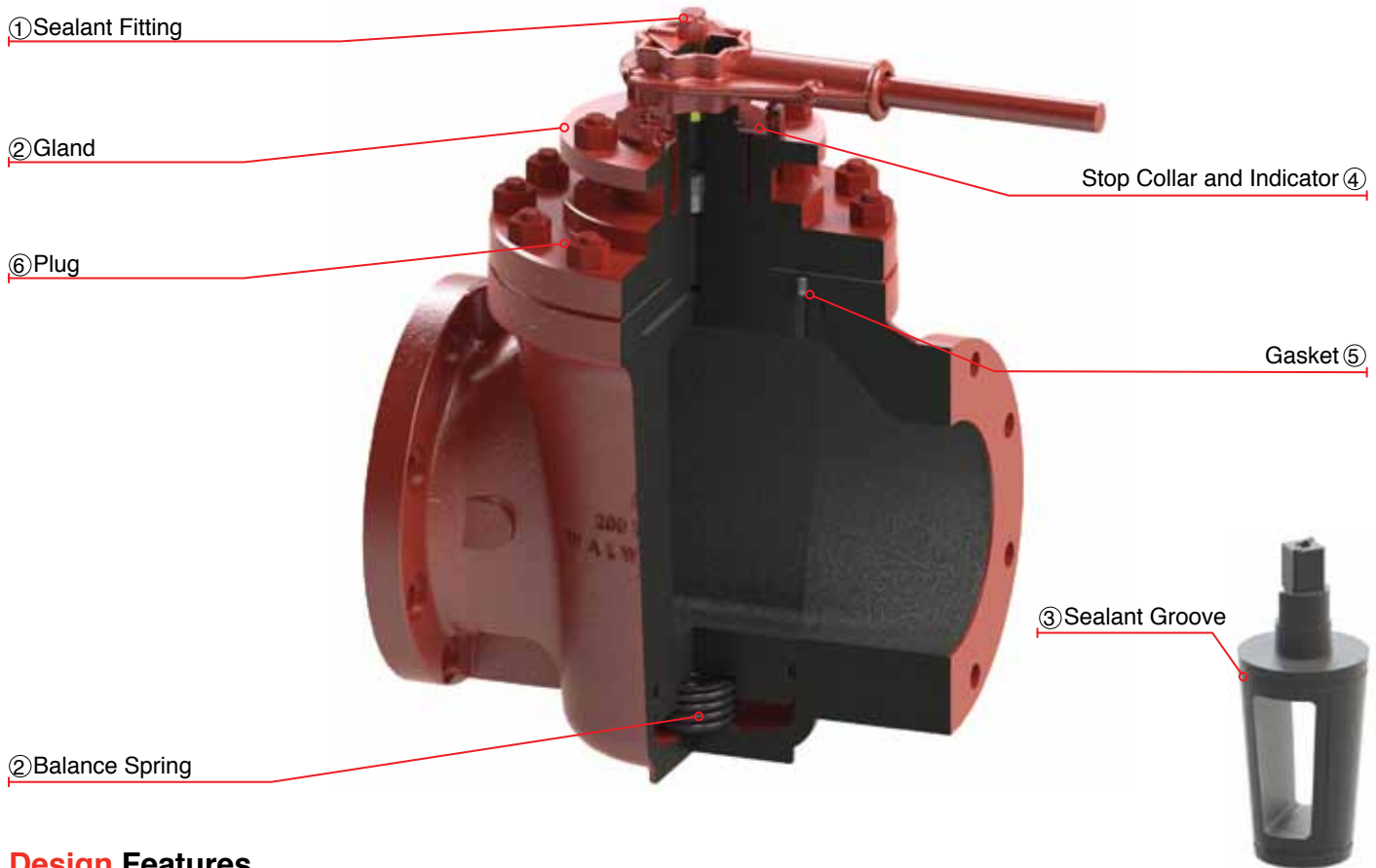

Design Features

- ① **Sealant Fitting.** Fast Sealant Injection that can be removed under pressure. The system includes Ball Check valves in order to prevent the back pressure and maintain the pressure in the sealant cavity.
- ② **Balancing Spring.** the mechanical spring type SS 304 is under compression and holds the plug in an equalized pressure position, thus eliminating the possibility of plug taper lock.
- ③ **Sealant Grooves.** this system permits sealant injection while the valve is under full line pressure. WALWORTH recommends that the valves be lubricated with plug in the fully opened or fully closed position for optimum valve performance.
- ④ **Open/Closed Indicator.** quarter turn stop collar also functions as an indicator of the plug's position.
- ⑤ **Diaphragm Gasket.** ensures a complete sealing of the valve against leakage.
- ⑥ **Plug.** WALWORTH Plugs are designed with an specific coating material that reduces the coefficient of friction making the valve to operate with low torque.

IRON PLUG VALVE REGULAR PATTERN CLASS 200 CWP (Lever Operated)

Regular Bill of Materials

No.	Description	Material
1	BODY	ASTM A-126 CLASS B
2	GLAND	ASTM A-126 CLASS B
3	PLUG	ASTM A-126 CLASS B
4	STOP COLLAR	CARBON STEEL
5	GLAND STUD	ASTM A 307 Gr. B
6	GLAND NUT	ASTM A 194 Gr. 2H
7	GASKET	STAINLESS STEEL + GRAPHITE
8	WRENCH PIN	ASTM A568
9	GREASE FITTING	COMMERCIAL STEEL
10	TRUARC RING	COMMERCIAL STEEL
11	BALANCE SPRING	STAINLESS STEEL
12	O-RING	NITRILE BUTADIENE RUBBER
13	SEALANT CHECK VALVE	COMMERCIAL STEEL
14	PLUG CHECK VALVE	COMMERCIAL STEEL
15	COVER STUD	ASTM A 307 GRADE B
16	COVER NUT	ASTM A 194 Gr. 2H
17	COVER	ASTM A-126 CLASE B
18	WRENCH	GRAY IRON
19	SET SCREW	ALLOY STEEL

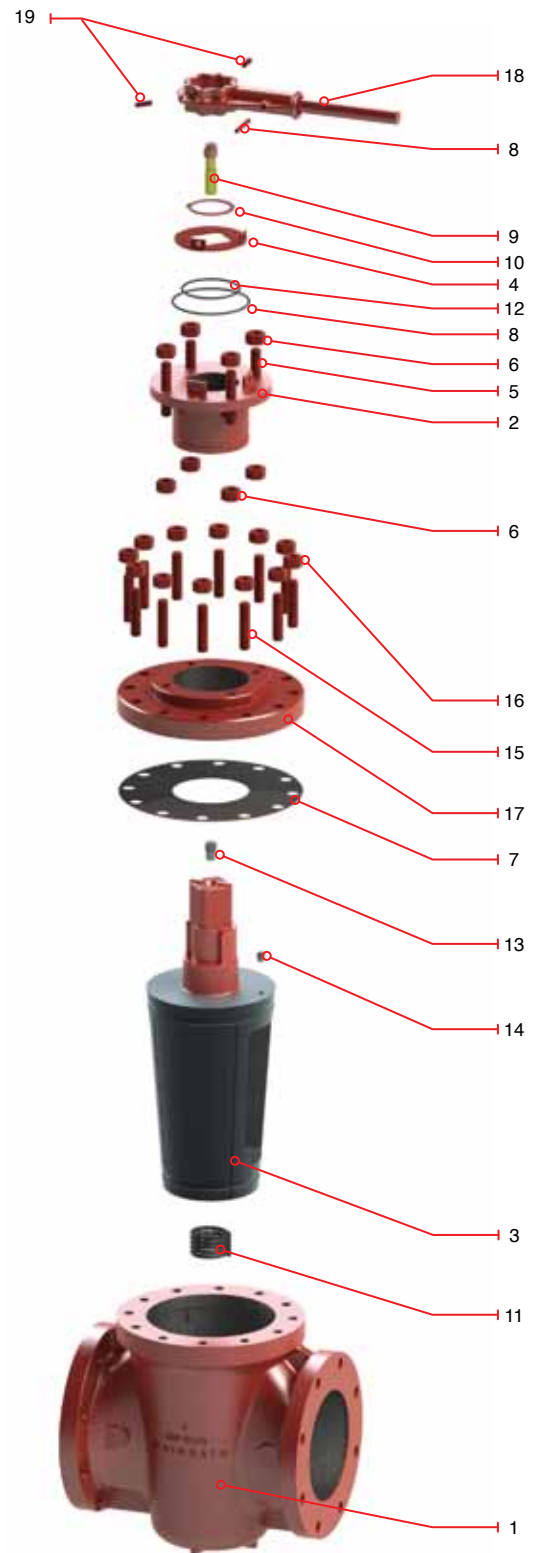

IRON PLUG VALVE REGULAR PATTERN (2-8 NPS) CLASS 200 CWP (Lever Operated)

Design Features

- Threaded ends in accordance with ASME B1.20.1
- Flat Face Flanged ends in accordance with ASME B16.1
- Design in accordance with API 599
- Test in accordance with API 598 & MSS SP 78

Figure no.	Operation	Type of ends
1700	Lever Operated	THREADED
1700 F	Lever Operated	FLANGED FLAT FACE

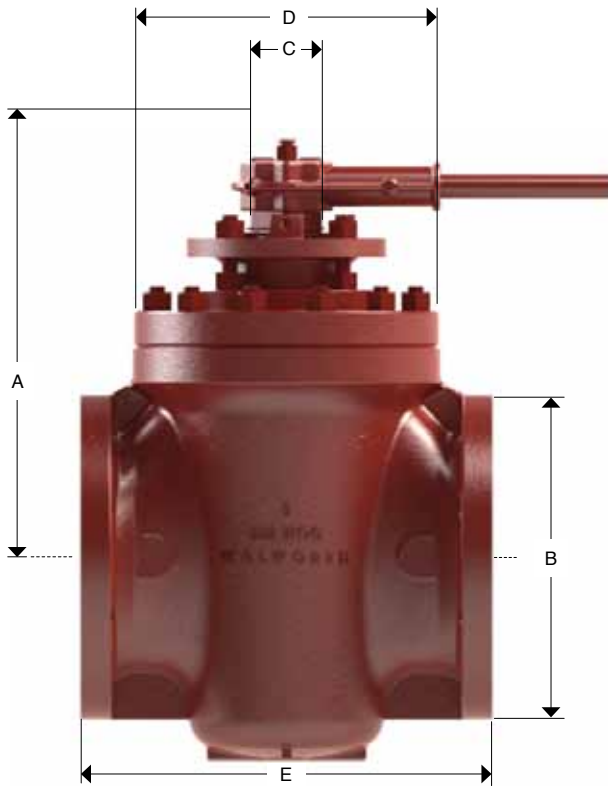

Dimensions and Weights

Nominal Size		General Dimensions								End to End Dimensions				Approx Weight				Wrench No.
		A		B		C		D		E				FLAT FACE		THRD		
				FLAT FACE						FLAT FACE		THRD						
in	mm	in	mm	in	mm	in	mm	in	mm	in	mm	in	mm	lb	kg	lb	kg	
2	50	7.37	187	6	152	1.25	32	4.31	109	7.5	191	6.5	165	31	14.1	26.0	11.8	DB G-1
3	75	9	229	7.5	191	1.37	35	5.5	140	9	229	8.06	205	59	26.8	57.0	25.9	DB M-1
4	100	10.81	275	9	229	1.5	38	8.37	213	12	305	-	-	128	58.1	-	-	DB P-1
6	150	13.12	333	11	279	2	51	10.87	276	15.5	394	-	-	255	115.8	-	-	T-3
8	200	16.5	419	13.5	343	2.43	62	13.5	343	18	457	-	-	457	207.5	-	-	V-3

IRON PLUG VALVE REGULAR PATTERN CLASS 200 CWP (Gear Operated)

Regular Bill of Materials

No.	Description	Material
1	BODY	ASTM A-126 CLASS B
2	GLAND	ASTM A-126 CLASS B
3	PLUG	ASTM A-126 CLASS B
4	GLAND SCREW	ASTM A 307 Gr. B
5	GLAND STUD	ASTM A 194 Gr. 2H
6	GASKET	STAINLESS STEEL + GRAPHITE
7	GREASE FITTING	COMMERCIAL STEEL
8	BALANCE SPRING	STAINLESS STEEL
9	O-RING	NITRILE BUTADIENE RUBBER
10	SEALANT CHECK VALVE	COMMERCIAL STEEL
11	PLUG CHECK VALVE	COMMERCIAL STEEL
12	COVER STUD	ASTM A 307 GRADE B
13	COVER NUT	ASTM A 194 Gr. 2H
14	COVER	ASTM A-126 CLASE B
15	GEAR OPERATOR	COMERCIAL STEEL
16	GEAR OPERATOR SUPPORT	CARBON STEEL
17	GEAR OPERATOR BOLTING	ASTM A 307 Gr. B
18	STEM EXTENSION	ASTM A 322 GRADE 4140
19	STOP COLLAR	CARBON STEEL

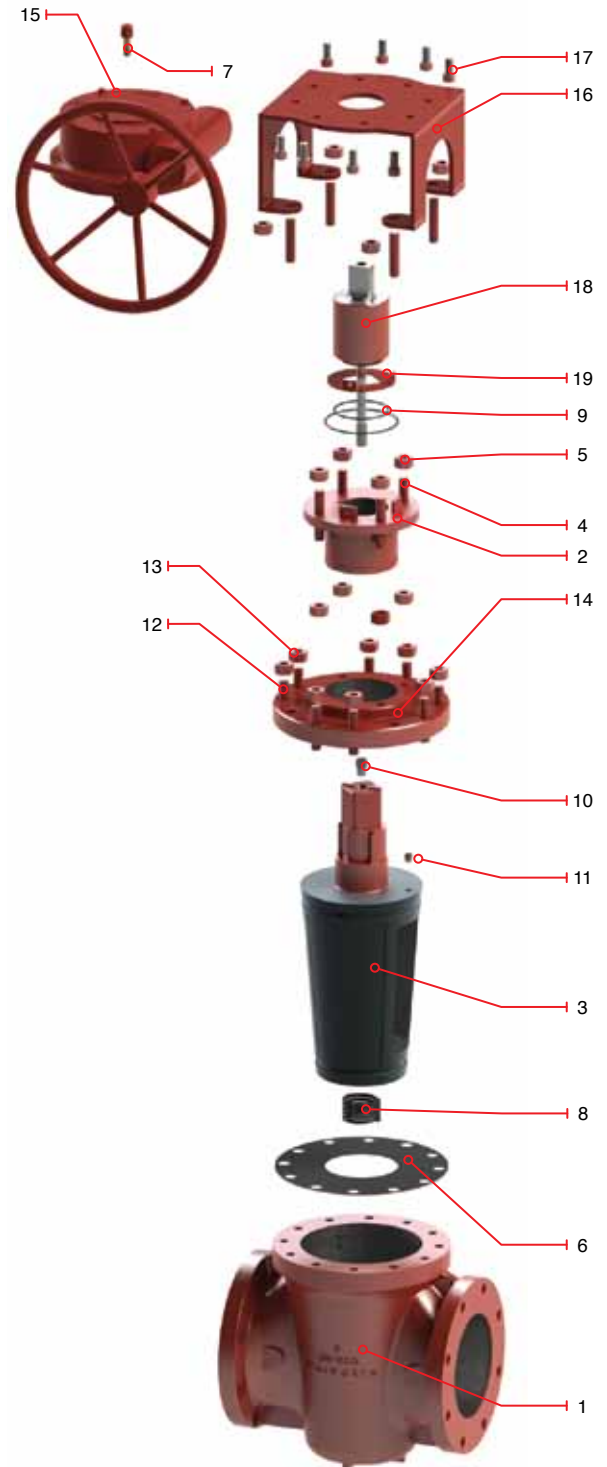

IRON PLUG VALVE REGULAR PATTERN (6-12 NPS) CLASS 200 CWP (Gear Operated)

Design Features

- Flat Face Flanged ends in accordance with ASME B16.1
- Design in accordance with API 599
- Test in accordance with API 598 & MSS SP 78

Figure no.	Operation	Type of ends
1707 F	Gear Operated	Flanged Flat Face

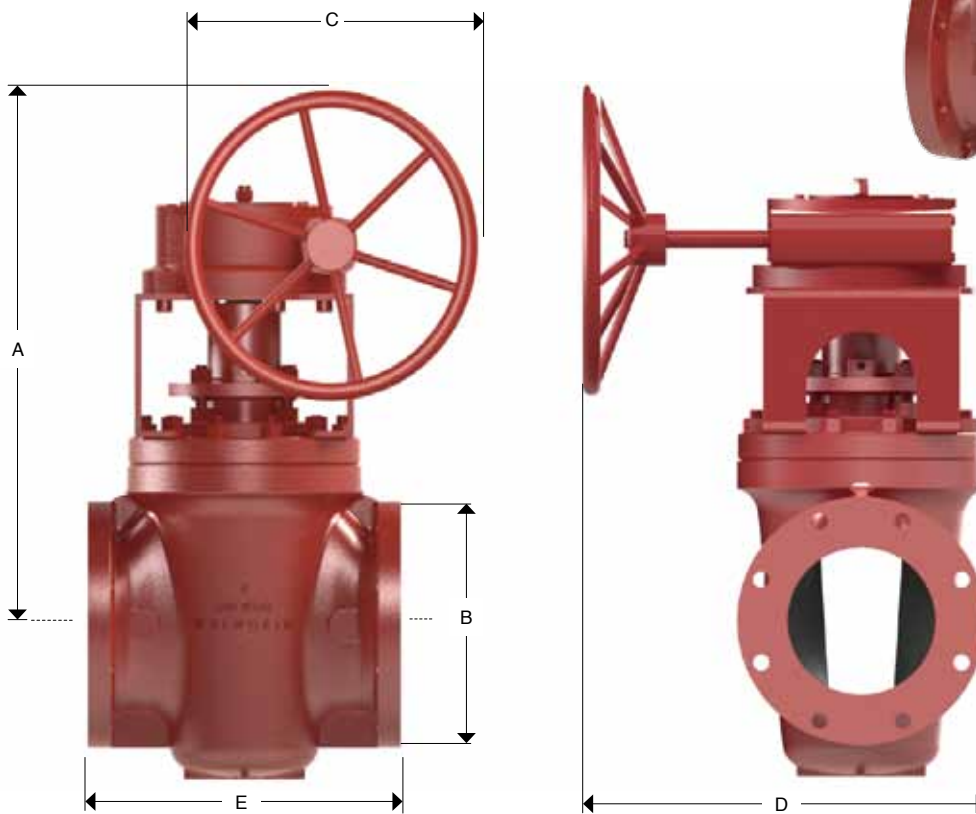

Dimensions and Weights

Nominal Size		General Dimensions								End to End Dimensions		Approx Weight	
		A		B		C		D (approx)		E		FLAT FACE	
in	mm	in	mm	in	mm	in	mm	in	mm	in	mm	lb	kg
6	150	18.68	474	11	279	23	584	20	508	15.5	394	330	149.8
8	200	21	533	13.5	343	23	584	22	559	18	457	540	245.2
10	250	23.56	598	16	406	23	584	26	660	21	533	924	419.5
12	300	27.87	708	19	483	23	584	31	787	24	610	1310	594.7

IRON PLUG VALVE VENTURI PATTERN CLASS 175 CWP

Regular Gland Type

DESIGN FEATURES

WALWORTH Regular Gland type Lubricated Venturi Plug Valves has a smaller port than the other two patterns. Its lower in cost, flow contours maximize hydraulic efficiency.

These Valves are all provided with separate retainers (cover plate) and adjusting glands; generally sizes 3" and smaller have four-bolt square retainers, while 4 inches and large sizes have round retainers. They all incorporate the Pressure Sealed Lubrication features.

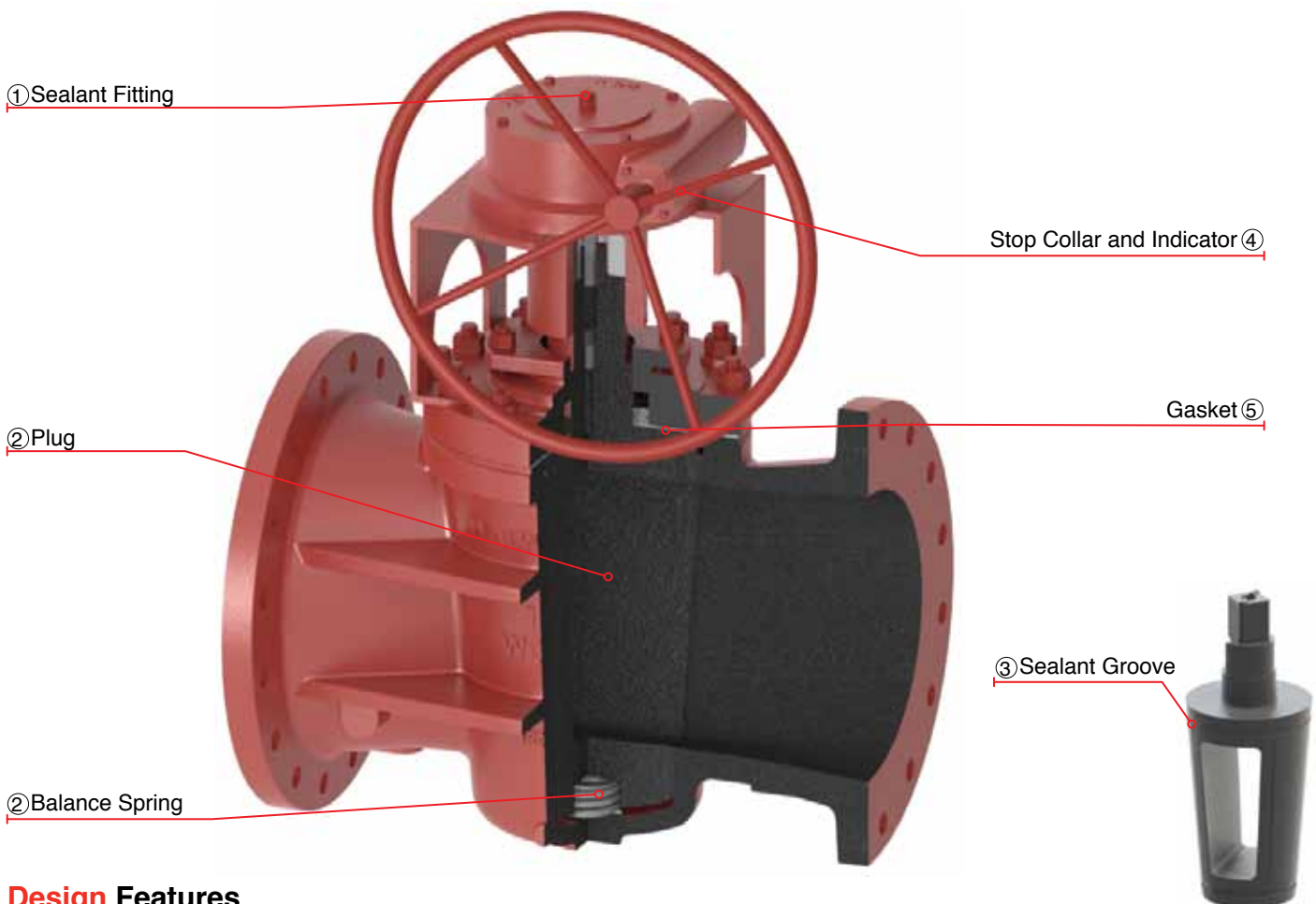

Design Features

- ① **Sealant Fitting.** Fast Sealant Injection that can be removed under pressure. The system includes Ball Check valves in order to prevent the back pressure and maintain the pressure in the sealant cavity.
- ② **Balancing Spring.** the mechanical spring type SS 304 is under compression and holds the plug in an equalized pressure position, thus eliminating the possibility of plug taper lock.
- ③ **Sealant Grooves.** this system permits sealant injection while the valve is under full line pressure. WALWORTH recommends that the valves be lubricated with plug in the fully opened or fully closed position for optimum valve performance.
- ④ **Open/Closed Indicator.** quarter turn stop collar also functions as an indicator of the plug's position.
- ⑤ **Diaphragm Gasket.** ensures a complete sealing of the valve against leakage.
- ⑥ **Plug.** WALWORTH Plugs are designed with an specific coating material that reduces the coefficient of friction making the valve to operate with low torque.

IRON PLUG VALVE VENTURI PATTERN CLASS 175 CWP (Gear Operated)

Regular Bill of Materials

No.	Description	Material
1	BODY	ASTM A-126 CLASS B
2	GLAND	ASTM A-126 CLASS B
3	PLUG	ASTM A-126 CLASS B
4	GLAND SCREW	ASTM A 307 Gr. B
5	GLAND STUD	ASTM A 194 Gr. 2H
6	GREASE FITTING	COMMERCIAL STEEL
7	DIAPHRAGM	ASTM A240 TIPO 304
8	BALANCE SPRING	STAINLESS STEEL
9	O-RING	NITRILE BUTADIENE RUBBER
10	SEALANT CHECK VALVE	COMMERCIAL STEEL
11	PACKING RETAINER	STEEL
12	COVER STUD	ASTM A 307 GRADE B
13	COVER NUT	ASTM A 194 Gr. 2H
14	COVER	ASTM A-126 CLASE B
15	GEAR OPERATOR	COMERCIAL STEEL
16	GEAR OPERATOR SUPPORT	CARBON STEEL
17	GEAR OPERATOR BOLTING	ASTM A 307 Gr. B
18	STEM EXTENSION	ASTM A 322 GRADE 4140
19	KEY	ASTM A 108 GRADE 1020
20	BUSHING	ASTM A 322 GRADE 4140
21	COVER GASKET	BLUE GUARD
22	GASKET	BLUE GUARD

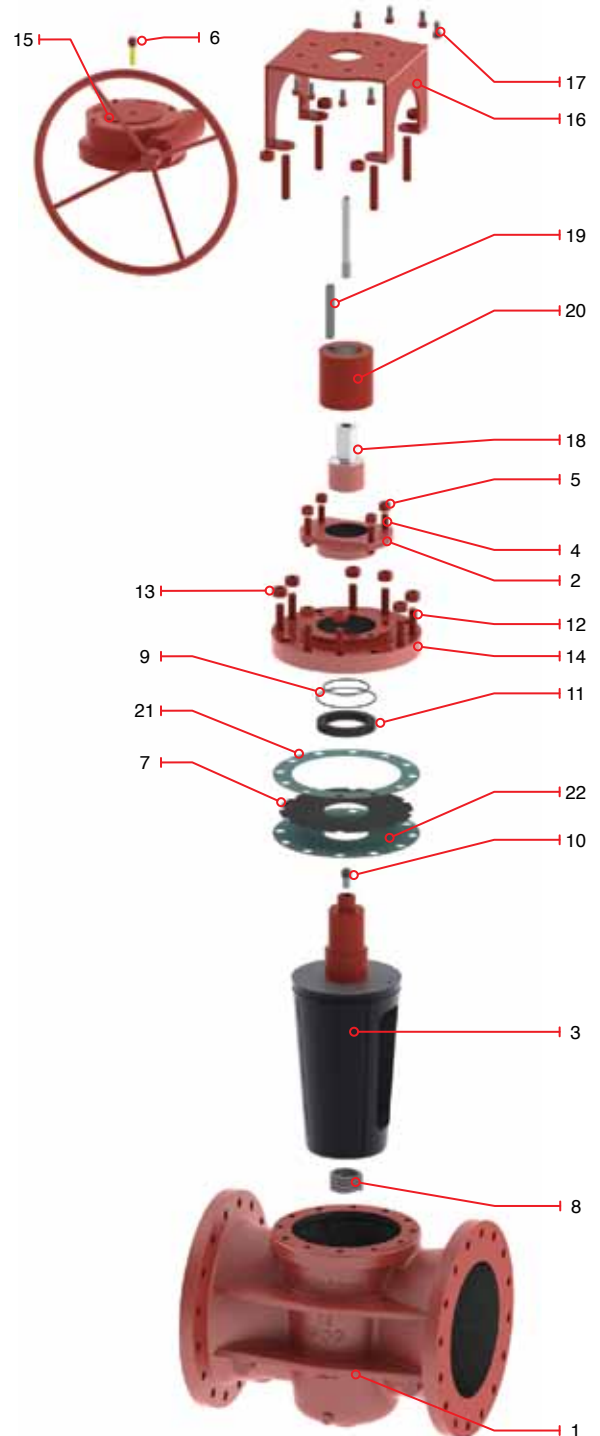

IRON PLUG VALVE VENTURI PATTERN (14-18 NPS) CLASS 175 CWP (Gear Operated)

Design Features

- Flat Face Flanged ends in accordance with ASME B16.1
- Design in accordance with API 599
- Test in accordance with API 598 & MSS SP 78

Figure no.	Operation	Type of ends
1703F	Gear Operated	FLANGED FLAT FACE

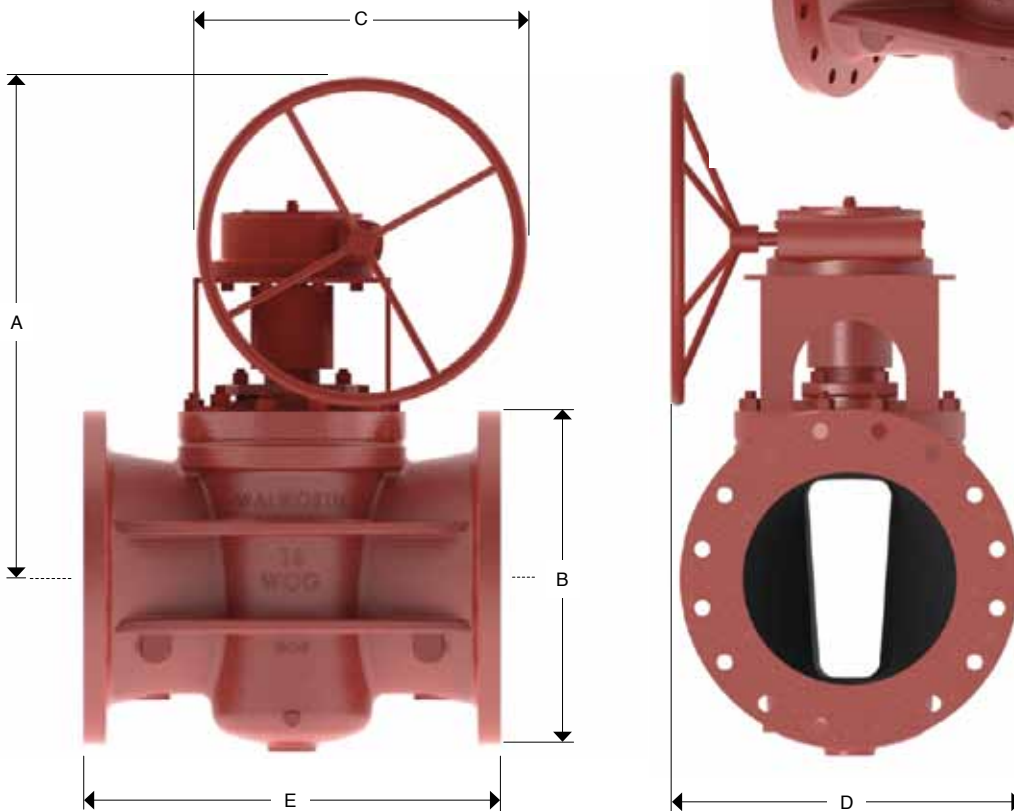

Dimensions and Weights

Nominal Size		General Dimensions								End to End Dimensions		Approx Weight	
		A		B		C		D		E		FLAT FACE	
in	mm	in	mm	in	mm	in	mm	in	mm	in	mm	lb	kg
14	350	20.37	517	27	686	26	660	29	737	27	686	1256	570.2
16	400	21.62	549	30	762	26	660	32	812	30	762	1455	660.6
18	450	23.37	594	34	864	30	762	35	889	34	864	1890	858.1

IRON PLUG VALVE VENTURI PATTERN CLASS 500 CWP

Regular Gland Type

DESIGN FEATURES

WALWORTH Regular Gland type Lubricated Plug Valves are designed to control plug adjustment tightening the gland, requesting only a very low maintenance in the field.

These Valves are all provided with separate retainers (cover plate) and adjusting glands; generally sizes 3" and smaller have four-bolt square retainers, while 4 inches and large sizes have round retainers. They all incorporate the Pressure Sealed Lubrication features.

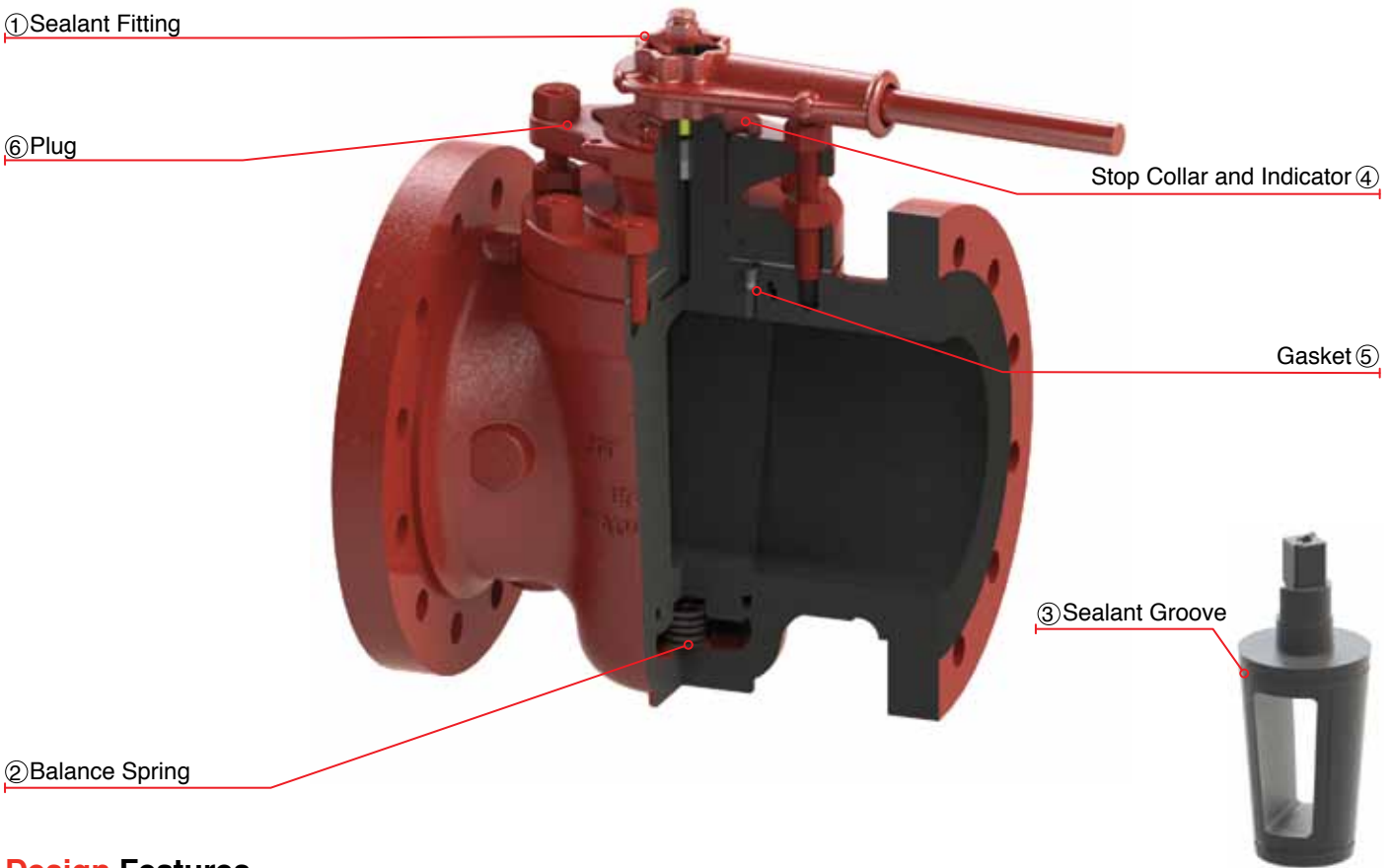

Design Features

- ① **Sealant Fitting.** Fast Sealant Injection that can be removed under pressure. The system includes Ball Check valves in order to prevent the back pressure and maintain the pressure in the sealant cavity.
- ② **Balancing Spring.** the mechanical spring type SS 304 is under compression and holds the plug in an equalized pressure position, thus eliminating the possibility of plug taper lock.
- ③ **Sealant Grooves.** this system permits sealant injection while the valve is under full line pressure. WALWORTH recommends that the valves be lubricated with plug in the fully opened or fully closed position for optimum valve performance.
- ④ **Open/Closed Indicator.** quarter turn stop collar also functions as an indicator of the plug's position.
- ⑤ **Diaphragm Gasket.** ensures a complete sealing of the valve against leakage.
- ⑥ **Plug.** WALWORTH Plugs are designed with an specific coating material that reduces the coefficient of friction making the valve to operate with low torque.

IRON PLUG VALVE VENTURI PATTERN CLASS 500 CWP (Lever Operated)

Regular Bill of Materials

No.	Description	Material
1	BODY	ASTM A-126 CLASS B
2	GLAND	ASTM A-126 CLASS B
3	PLUG	ASTM A-126 CLASS B
4	STOP COLLAR	CARBON STEEL
5	GLAND STUD	ASTM A 307 Gr. B
6	GLAND NUT	ASTM A 194 Gr. 2H
7	GASKET	STAINLESS STEEL + GRAPHITE
8	WEATHER SEAL	NITRILE BUTADIENE RUBBER
9	GREASE FITTING	COMMERCIAL STEEL
10	RING RETAINER	COMMERCIAL STEEL
11	BALANCE SPRING	STAINLESS STEEL
12	O-RING	NITRILE BUTADIENE RUBBER
13	SEALANT CHECK VALVE	COMMERCIAL STEEL
14	PLUG CHECK VALVE	COMMERCIAL STEEL
15	COVER STUD	ASTM A 307 GRADE B
16	COVER NUT	ASTM A 194 Gr. 2H
17	COVER	ASTM A-126 CLASE B
18	WRENCH	GRAY IRON
19	SET SCREW	ALLOY STEEL
20	WRENCH PIN	ASTM A568

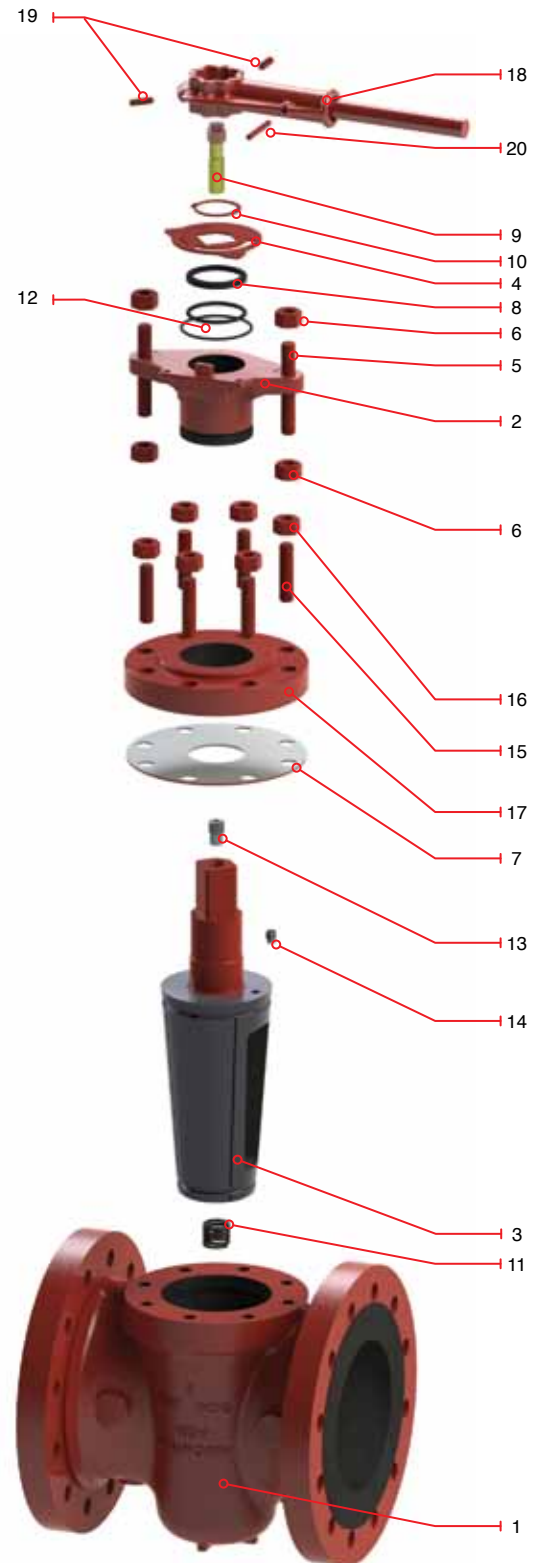

IRON PLUG VALVE VENTURI PATTERN CLASS 500 CWP (Lever Operated)

Design Features

- Flat Face Flanged ends in accordance with ASME B16.1
- Design in accordance with API 599
- Test in accordance with API 598 & MSS SP 78

Figure no.	Operation	Type of ends
2721F	Lever Operated	FLANGED FLAT FACE

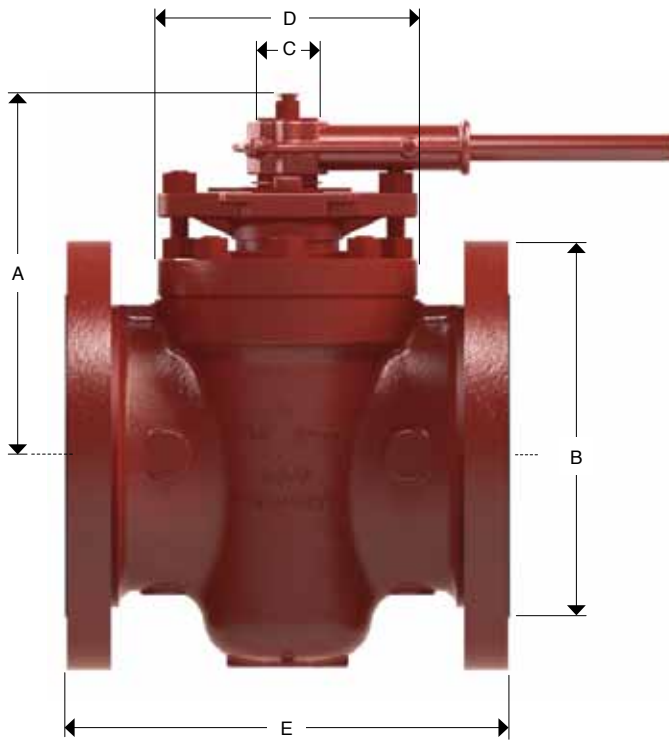

Dimensions and Weights

Nominal Size		General Dimensions								End to End Dimensions		Approx Weight		Wrench No.	Operating nut
		A		B		C		D		E	FLAT FACE				
in	mm	in	mm	in	mm	in	mm	in	mm	in	mm	lb	kg		
6	150	10.56	268	12.5	318	1.5	38	8.37	213	15.87	99.4	219.0	99	P-1	LN-6
8	200	12.25	311	15	381	1.75	44	9.62	244	16.5	153.0	337.0	153	R-3	LN-7

IRON PLUG VALVE VENTURI PATTERN CLASS 500 CWP (Gear Operated)

Regular Bill of Materials

No.	Description	Material
1	BODY	ASTM A-126 CLASS B
2	GLAND	ASTM A-126 CLASS B
3	PLUG	ASTM A-126 CLASS B
4	GLAND SCREW	ASTM A 307 Gr. B
5	GLAND STUD	ASTM A 194 Gr. 2H
6	GASKET	STAINLESS STEEL + GRAPHITE
7	GREASE FITTING	COMMERCIAL STEEL
8	BALANCE SPRING	STAINLESS STEEL
9	O-RING	NITRILE BUTADIENE RUBBER
10	SEALANT CHECK VALVE	COMMERCIAL STEEL
11	PLUG CHECK VALVE	COMMERCIAL STEEL
12	COVER STUD	ASTM A 307 GRADE B
13	COVER NUT	ASTM A 194 Gr. 2H
14	COVER	ASTM A-126 CLASE B
15	GEAR OPERATOR	COMERCIAL STEEL
16	GEAR OPERATOR SUPPORT	CARBON STEEL
17	GEAR OPERATOR BOLTING	ASTM A 307 Gr. B
18	STEM EXTENSION	ASTM A 322 GRADE 4140
19	STOP COLLAR	CARBON STEEL

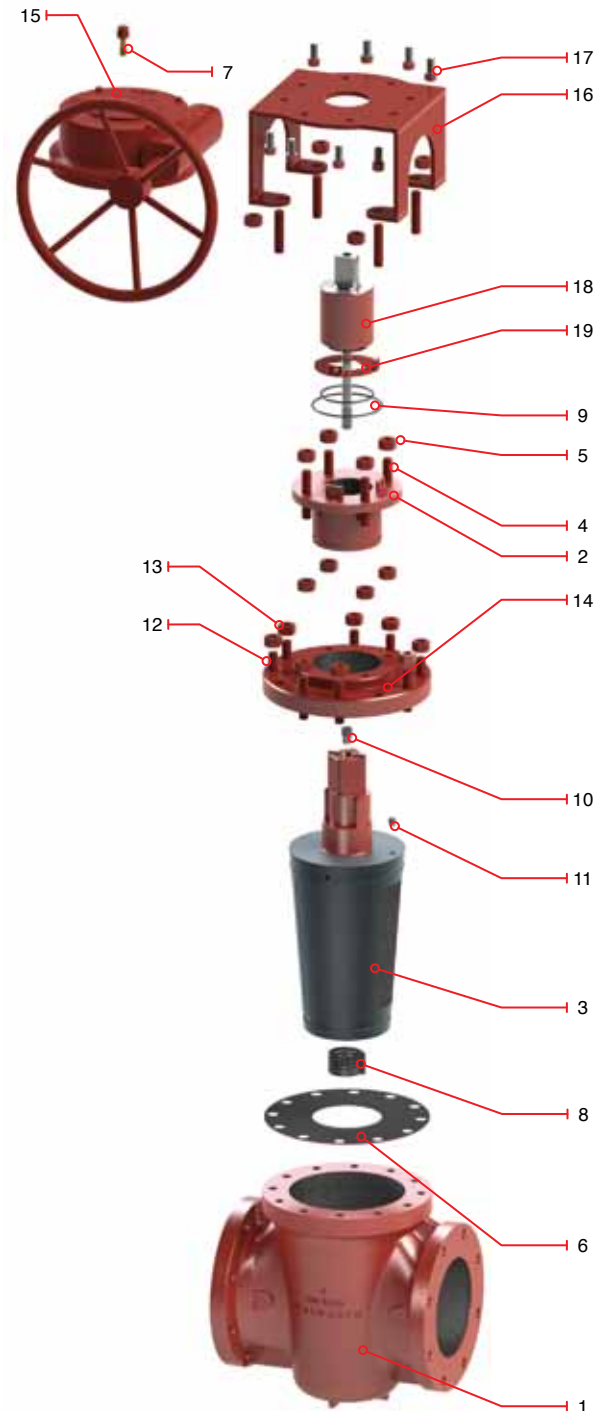

IRON PLUG VALVE VENTURI PATTERN CLASS 500 CWP (Gear Operated)

Design Features

- Flat Face Flanged ends in accordance with ASME B16.1
- Design in accordance with API 599
- Test in accordance with API 598 & MSS SP 78

Figure no.	Operation	Type of ends
2723F	Gear Operated	FLANGED FLAT FACE

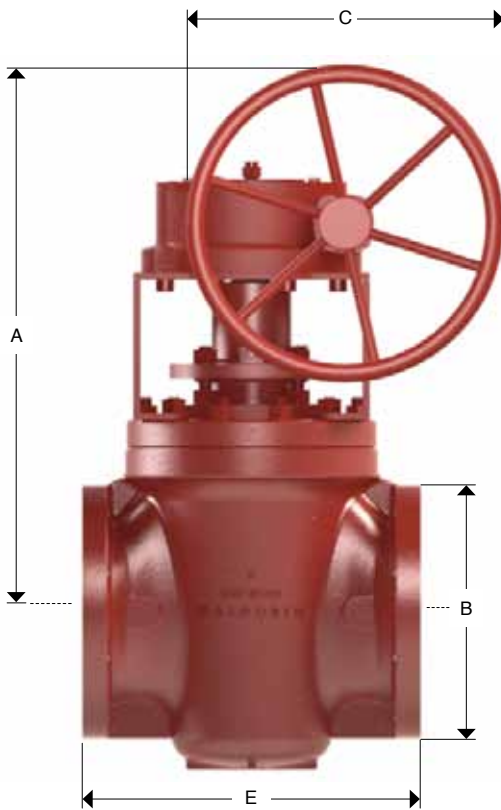

Dimensions and Weights

Nominal Size		General Dimensions								End to End Dimensions		Approx Weight	
		A		B		C		D		E		FLAT FACE	
in	mm	in	mm	in	mm	in	mm	in	mm	in	mm	lb	kg
6	150	10.56	268	12.5	318	26	660	11	279	15.87	403	294	133.5
8	200	12.25	311	15	381	26	660	13	330	16.5	419	420	190.7

TECHNICAL INFORMATION

PLUG VALVES WRENCHES

TOP ENTRY IRON PLUG VALVES WRENCHES

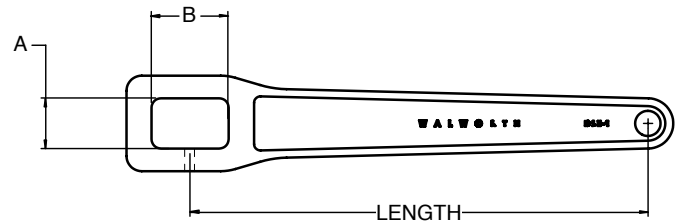

WRENCH NUMBER	SIZE OPENING		HANDLE LENGTH	VALVE SIZE	FOR USE WITH VALVE FIGURE
	A	B			
DB D - 4	0.905"	1.250"	9"	1/2", 3/4", 1"	1796, 1797F,
DB E - 1	1.000"	1.516"	9"	1 1/4", 1 1/2"	1796, 1797F,
DB G - 1	1.127"	1.620"	9"	2", 2 1/2"	1796, 1797F, 1700, 1700F
DB M - 1	1.350"	2.000"	15"	3"	1796, 1797F, 1700, 1700F
DB P - 1	1.375"	2.188"	30"	4"	1796, 1797F, 1700, 1700F
DB P - 1.1	1.375"	2.500"	30"	5"	1796, 1797F, 1700, 1700F
P - 1	1.600"	1.600"	30"	6"	1718F, 2721F
R - 3	1.781"	1.781"	36"	8"	1718F, 2721F
T - 3	2.094"	2.094"	36"		10-1718F, 6-1700/1700F
V - 3	2.426"	2.426"	48"		12-1718F, 8-1700/1700F

2" SQUARE OPERATING NUTS USED IN TOP ENTRY IRON PLUG VALVES

OPERATING No.	VALVE SIZE	FOR USE WITH VALVE FIGURE
DB LN-1	1/2", 3/4", 1"	1796, 1797F
DB LN-2	1 1/4", 1 1/2"	1796, 1797F
DB LN-3	2", 2 1/2"	1796, 1797F, 1700, 1700F
DB LN-5	3"	1796, 1797F, 1700, 1700F
DB LN-6	4"	1796, 1797F, 1718F, 1700, 1700F
DB LN-6.1	5"	1796, 1797F, 1718F, 1700, 1700F
LN-6	6"	1718F
LN-7	8"	1718F

CORRESPONDING OPERATING NUT AND RECTANGLE

OPERATING NUT	OPENING DIMENSION	
	Ø	A
DB LN-1	1.250	0.907
DB LN-2	1.500	1.000
DB LN-3	1.600	1.120
DB LN-5	2.000	1.350
DB LN-6	2.200	1.375
DB LN-6.1	2.400	1.750
LN-6	1.532 sq	
LN-7	1.750 sq	

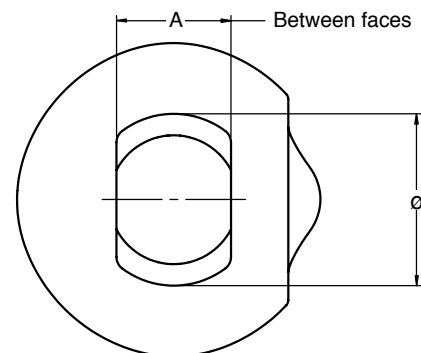

TECHNICAL INFORMATION

WALSEAL PLUG VALVES SEALANT

FUNCTION AND PROPERTIES OF WALSEAL SEALANTS

To assure thoroughly satisfactory service, WALWORTH Walseal Sealants should always be used with WALWORTH Plug Valves.

Function: The sealant minimizes friction during operation of the valve and protects seating surfaces from corrosion. Because the ports of valves are completely encircled with sealant grooves, leakage is prevented by the Walseal sealant.

Properties: Walseal sealants have the necessary properties to serve a variety of purposes.

1. Have lubricating value to allow the valve to turn easily.
2. Have sufficient body to resist dilution by line fluids and still assure tight sealing.
3. Are chemically inert in the fluids for which they are specified and have the ability to adhere to the metal of the finished seating surfaces to protect from corrosion.
4. Remains in a plastic state over a wide range of temperature conditions to act as a hydraulic medium, and provide for lubrication and corrosion protection.
5. Contain a minimum of Ingredients that might solidify from temperature or chemical reactions and clog the groove system.

2. Color.- Where discoloration of the line contents must be guarded against, select a white sealant If available. In special cases consult a WALWORTH representative.
3. Contamination - Sealant for use with foodstuffs or pharmaceuticals must be non-toxic, taste and color-free and chemically inert.
4. Temperature - As a general rule, choose the sealant with the lowest maximum temperature rating. Such a sealant will usually have greater lubricating value at normal temperatures than one with a higher limit. This is important as it affects the ease of operation of the valve.
5. Compromise - If a sealant is required for a mixed service condition, a good practical rule is to select the sealant recommended to the predominating part of the pipe-line contents.
6. Nitrating Acids - It is dangerous to use certain sealants on nitrating acids. Please contact your WALWORTH representative for this application.

Proper sealant maintenance:

The amount of maintenance required depends upon the frequency of operation of the valve.

Regular maintenance: Preserves the seating surfaces and prevents leakage. Definite periodic service gives the best results. Any valve not regularly operated should be serviced at least every six months.

SELECTION AND MAINTENANCE OF WALSEAL SEALANT

How to select a sealant:

1. Line Contents - Select a sealant recommended for the particular service requirements.

Ordering Information:

1. State whether jumbo, stick or bulk sealant is desired.
2. For bulk sealant give Walseal number and container size.

STICK	STICK SIZE	AVAILABLE IN WALSEAL NO.
B (24/box)	318' X 1 1/2' (Box approx. 1.2 lb.)	10, 20, 40 and 60
C (24/box)	7/16' X 2 1/8' (Box approx. 1.2 lb.)	10, 20, 40 and 60
D (24/box)	1/2' X 2 1/4' (Box approx. 1.2 lb.)	10, 20, 40 and 60
G (24/box)	5/8' X 3 1/2' (Box approx. 1.2 lb.)	10, 20, 40 and 60
CARTRIDGE - (Box of 4 - 1 lb. each)		ALL TYPES
BULK		
J-Jumbo Jr. (6)	1 3/8' X 8 1/2' (Box approx. 3.2 lb.)	10, 20, 40 and 60
K-Jumbo (12)	1 1/2' X 10 1/2' (Box approx. 9.2 lb.)	10, 20,40 and 60
Gun Pack (Box-6 GP)		ALL TYPES
10 pound (5 quart can)		
40 pound (5 gallon can)		
400 pound (55 gallon drum)		

TECHNICAL INFORMATION

WALSEAL PLUG VALVES SEALANT

WALSEAL #10

Temperature range from -20F to 500F Stick / -40F to 500F Bulk
Dark Gray

Service: General purpose sealant intended for use in natural gas and liquid petroleum services including crude distillates, combustible fuels such as gasoline, jet fuel, and heating oils. Used as assembly sealant in all WALWORTH plug valves unless otherwise specified.

Not intended for use in: Solvents (aromatic), strong acids and alkalies, and steam.

WALSEAL #20

Temperature range from 0F to 650F Bulk / 30F to 690F Stick
Color red

Service: High temperature general purpose sealant for use in acids, alkalies, alcohols, amines, asphalt, aqueous solutions, fats, glycerine glycols, soap, steam, and water service having continuous exposure to temperatures above 400F.

Not intended for use in: Aromatic solvent light liquid hydrocarbons, nitrating acids.

WALSEAL #40

Temperature range from 1 0F to 350F Stick / -10F to 350F Bulk
Color light brown

Service: Specifically formulated for resistance to all octane gasolines, aviation and jet fuels, kerosene, fuel blending ingredients, and water. Approved for government use per MIL-G-6032.

Not intended for use in: Strong acids and alkalies.

WALSEAL #50

Temperature range from -50F to 300F
Color beige

Service: Low temperature general purpose sealant for use in services similar to Walseal #10. Recommended for continuous exposure to temperatures below 0°F.

Not intended for use in: Solvents (aromatic and chlorinated), strong acids and alkalies.

WALSEAL #60

Temperature range from 1 0F to 350F Stick / 0F to 300F Bulk
Service: Suitable for water, acids, alkalies, alcohols, and amines. May be used in food or pharmaceutical applications if approved by user. Certified by the National Sanitary Foundation.

Not intended for use in: Hydrocarbon solvents.

Continued use of any sealant at either the low or high temperature limit is not recommended.

For more information concerning these sealants or recommendations for a particular service contact your WALWORTH representative.

WALWORTH VALVE FLUSH

For hard-to-operate valves

-20°F to 400°F

(-28°C) (204°C) BLACK

VALVE FLUSH is not a sealant; however, it is compatible with any lubricant or sealant. It contains molybdenum disulfide for added lubricity. VALVE FLUSH may be applied with conventional lubricating equipment.

VALVE FLUSH will work through any fitting that is not completely plugged. In other words, if VALVE FLUSH cannot be injected past the fitting, it will not free the valve. If the fitting is plugged, then it is recommended that fitting be removed and replaced with the appropriate WALWORTH fitting.

WALWORTH "VALVE FLUSH" JUMBO, JR. BAG 6/BX

WALWORTH "VALVE FLUSH" JUMBO, BAG 6/BX

WALWORTH "VALVE FLUSH" 1 CARTRIDGE 12/CTN

WALWORTH "VALVE FLUSH" 10LB. (5QT.) CAN.

WALWORTH "VALVE FLUSH" 20 LB. (3GAL.) PAIL

WALWORTH "VALVE FLUSH" 40 LB. (6GAL.) PAIL

TECHNICAL INFORMATION

LUBRICANT ACCESORIES

1002 WALSEAL HYDRAULIC DELTA STICK SEALANT GUN, FOR USE WITH "K" SIZED SEALANT.

1699 HIGH PRESSURE LUBRICANT GUN

1699 G HIGH PRESSURE LUBRICANT GUN WITH GAUGE

Where a number of valves are installed under the same, or related, service conditions it is advantageous to lubricate them with a **WALWORTH High Pressure Lubricant Gun**.

The WALWORTH High Pressure Lubricant Gun is the only portable gun that can handle lull-bodied valve lubricants in stick form.

The gun is self-priming and may be used in any position. The pump handle is detachable and has a hole drilled near one end.

By detaching the handle and placing the hole over the protruding button on the charging cap, the cap can readily be removed and replaced.

The handle is also used as a pusher for returning the piston to the bottom of the cylinder for the purpose of charging the gun.

To charge the gun the by-pass is opened and the piston pushed down as far as it will go. The by-pass valve is then closed and two

sticks of WALWORTH Jumbo Size Lubricant inserted. Then the charging cap is replaced, using the pump handle and protruding button on the cap to tighten it, and the gun is ready for use. The lever handle is then pumped until sealant appears at the end of the hose.

During operation of the gun, should the pressure created lock the coupling to the button-head filling, the pressure can be relieved and the coupling disconnected by opening the bypass valve. Relief fittings are provided on the hose and within the gun to prevent valve damage should the lubricating system be clogged, or prevent damage to the gun itself in the event it is operated when empty.

HIGH PRESSURE GAUGE

For use with Sealant hand guns and pumps. An essential accessory to indicate when sufficient Sealant pressure has been developed.

Gauge needle pulsation goes up by steps until valve is completely filled with Sealant. When Sealant pressure reaches a certain point, the gauge needle begins to drop showing that the valve is lull. Gauge also indicates valve adjustment and other service required.



TECHNICAL INFORMATION

WALWORTH LUBRICANT FITTINGS

Most types of WALWORTH Lubricated Plug Valves are regularly provided with the WALWORTH Lubricant Fitting illustrated. It is a Giant Button-Head Fitting to which the lubricant gun may be coupled easily for a leakproof connection. These fittings may also be used as regular lubricant screws with standard size lubricant sticks.

One size of Button-Head Fitting is used for all Compensator Plug Valves. The Button-Head figure number for other WALWORTH Plug Valves is the same as the "Sealant Stick Size" listed on the catalog page for each valve type and size.



WALWORTH BUTTON-HEAD LUBRICANT FITTINGS	LUBRICANT FITTING SIZE	WALWORTH LUBRICANT FITTING NUMBER
For Standard Compensators	1/4"	BH1
For NACE MR0-01-75 Compensators	1/4"	BH1-N
For valves with Sealant Stick Size: B	1/4"	BH2
C	□	BH3
D	1/2	BH4
G	3/4	BH5

DOUBLE BALL CHECK VALVE ASSEMBLIES	
No.	Valve Size
B	1/2 to 2"
C	2 1/2 to 3"
D	4 & 5"
G	6" & up

TECHNICAL INFORMATION

PRESSURE AND TEMPERATURE RAITINGS

FLUID TEMPERATURE °F	CAST IRON PLUG VALVES ASTM A-126 CLASS B		
	175 CWP	200 CWP	500 CWP
-20 to 150	175	200	500
200	165	190	460
225	155	180	440
250	150	175	415
275	-	170	395
300	-	165	375
325	-	155	355
350	-	150	335
375	-	145	315
400	-	140	290
425	-	130	270
450	-	125	250
TEST PRESSURES PSI, MIN.			
HYDROSTATIC SHELL TEST	350	400	1000
SEAT (CLOSURE) TEST	275	300	750

Maximum allowable working pressures, derived from API 599, API 6D, ANSI B16.34 and/or MSS SP-78 are shown. For intermediate temperatures, linear interpolation may be used. Ratings for threaded valves smaller than 1" and for 175 CWP valves are manufacturer's. Application of ratings is subject to the temperature limitations of the sealants used. Applicable Codes and Standards should be consulted for restrictions on pressure, temperature and usage of the valves. Further reference should be made to individual description pages for additional comments or restrictions.

TECHNICAL INFORMATION

FLANGE DIMENSIONS AND TEMPLATES

CAST IRON FLANGE DIMENSIONS AND DRILLING TEMPLATES ANSI B 16.1

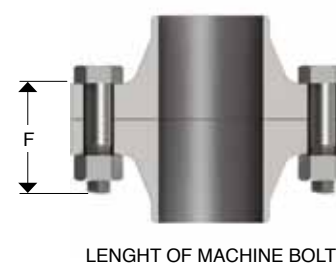
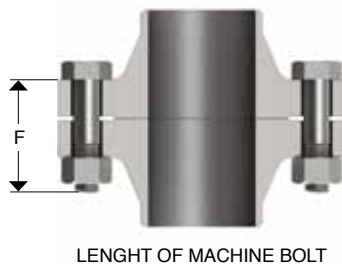
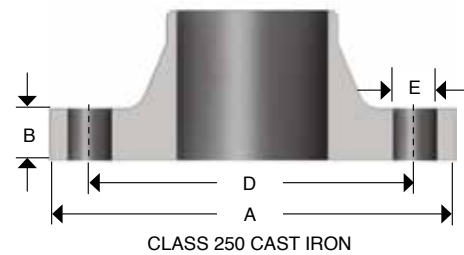
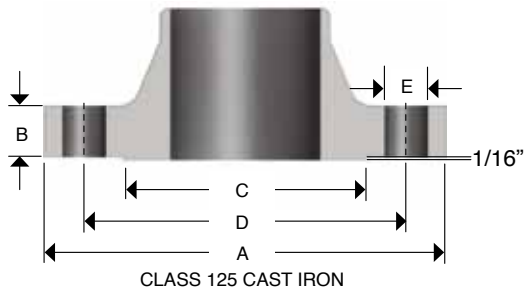

CLASS 125

NOMINAL PIPE SIZE	FLANGES		DRILLING		BOLTING		LENGHT OF MACHINE BOLTS F
	FLANGE DIAMETER A	FLANGE THIKNESS MIN B	DIAMETER OF VOLT CIRCLE D	DIAMETER OF BOLT HOLES E	NUMBER OF BOLTS	DIAMETER OF BOLTS	
1	4 1/4	7/16	3 1/8	5/8	4	1/2	1 3/4
1 1/4	4 5/8	1/2	3 1/2	5/8	4	1/2	2
1 1/2	5	9/16	3 7/8	5/8	4	1/2	2
2	6	5/8	4 3/4	3/4	4	5/8	2 1/4
2 1/2	7	3/4	5 1/2	3/4	4	5/8	2 1/2
3	7 1/2	15/16	6	3/4	4	5/8	2 1/2
4	9	15/16	7 1/2	3/4	8	5/8	3
5	10	15/16	8 1/2	7/8	8	3/4	3
6	11	1	9 1/2	7/8	8	3/4	3 1/4
8	13 1/2	1 1/8	11 3/4	7/8	8	3/4	3 1/2
10	16	1 3/16	14 3/4	1	12	7/8	3 3/4
12	19	1 1/4	17	1	12	7/8	3 3/4

Bolt lengths are for flanges of thickness shown herein. Bolt lengths should be checked for the thicker flanges shown in some individual valve description pages. When flanges integral with valves or fittings, the bolt holes, which are in multiples of four, are drilled to straddle the center lines unless otherwise ordered. Class 125 cast iron flanges have plain faces.

CLASS 250

NOMINAL PIPE SIZE	FLANGE THICKNESS			DRILLING		BOLTING		LENGHT OF MACHINE BOLTS F
	FLANGE DIAMETER A	FLANGE THIKNESS MIN B	DIAMETER OF RAISED FACE C	DIAMETER OF VOLT CIRCLE D	DIAMETER OF BOLT HOLES E	NUMBER OF BOLTS	DIAMETER OF BOLTS	
1	4 7/8	1 1/16	2 11/15	3 1/2	3/4	4	5/8	2 1/2
2	6 1/2	7/8	4 3/16	5	3/4	8	5/8	2 3/4
3	8 1/4	1 1/8	5 11/16	6 5/8	7/8	8	3/4	3 1/2
4	10	1 1/4	6 15/16	7 7/8	7/8	8	3	3 3/4

The 1/16-inch raised face on the Class 250 cast iron flanges is included in the dimension B for thickness of flange.

Bolt lengths are for flanges of thickness shown herein. Bolt lengths should be checked for the thicker flanges shown in some individual valve description pages.

DESIGN BASIS

All of WALWORTH's Valve Designs, when applicable, follow one or more of the following standards.

- | | |
|--|--|
| API Standards | American Petroleum Institute |
| | <ul style="list-style-type: none"> • API-598 Valve inspection and testing. • API-599 Steel and Ductil Iron Plug Valves. |
| ANSI Standards | National Standards Institute |
| | <ul style="list-style-type: none"> • B16.1 Cast Iron Pipe Flanged and Flanged Fittings • B16.10 Length of ferrous flanged and welding end valves • B1.20.1 Pipe Threads, General Purpose. • B16.34 Valves -Flad, Threaded and Welding End. |
| ASTM Standards | American Society for Testing and Materials |
| | <ul style="list-style-type: none"> • ASTM A126 Gray Iron Castings For valves, flanges and pipe fittings. • ASTM A193 Alloy-Steel and Stainless Steel Bolting Materials for High-Temperature Service • ASTM A194 Carbon and Alloy Steel nuts for bolts for High-Pressure and High-Temperature Service • ASTM A216 Steel Castings, Carbon, suitable for Fusion Welding for High-Temperature Service • ASTM A276 Stainles and Heat-Resisting Steel Bars and Shapes • ASTM A307 Carbon Stell bolts and studs , 60,000 psi Tensile • ASTM A320 Alloys - Steel bolting materials for Low-Temperature Service. • ASTM A352 Steel Castings, Ferritic and Martensitic, for Pressure-Containing Parts. Suitable for Low-Temperature Service. • ASTM A487 Steel Castings Suitable for Pressure Service • ASTM A515 Pressure Vessel Plates, Carbon Steel, for intermediate and High-Temperature Service. |
| MSS Standards | Manufacturers Standardization Society |
| | <ul style="list-style-type: none"> • MSS SP-6 Standard Finishes for Contact Faces of Pipe Flanges and Connecting-end Flanges of Valves and Fittings. • MSS SP-9 Spot Facing Bronze, Iron and Steel Flanges • MSS SP-25 Standard Marking System for Valves, Fittings, Flanges and Unions. • MSS SP-44 Steel Pipe Line Flanges • MSS SP-55 Visual Method • MSS SP-61 Pressure Testing of Steel Valves • MSS SP-78 Cast Iron Plug Valves, Flanged and Threaded Ends |
| NACE Standards | National Association of Corrosion Engineers |
| | <ul style="list-style-type: none"> • NACE MR-01-75 Standard material requirements sulfide stress cracking resistant metallic materials for oilfield equipment |
| ASME Codes | American Society of Mechanical Engineers |
| | <ul style="list-style-type: none"> • ANSI/ASME B31.1 Power Piping • ANSI/ASME B31.2 Fuel Gas Piping • ANSI/ASME B31.3 Process Piping • ANSI/ASME B31.4 Liquid Transportation Systems for Hydrocarbons • ANSI/ASME B31.8 Gas Transmission and Distribution Piping Systems • ANSI/ASME B31.9 Building Services Piping. |
| Boiler and Presure Vessel Code: | |
| | <ul style="list-style-type: none"> • Section II Material Specifications - Part A, B and C • Section V Non-Destructive Examination. • Section VIII Rules for construction of Pressure vessels, divisions 1 and 2 • Section IX Welding and Brazing Qualifications |

HOW TO ORDER

SIZE (INCH)	DESCRIPTION BY FIGURE NUMBER	BASE MATERIAL	SUPPLEMENTARY REQUIREMENTS
1/2"	1796= SINGLE GLAND TYPE; CWP 200, SHORT PATTERN, WRENCH OPERATED, THREADED ENDS.	CAST IRON ASTM A126 GRADE B	BS= Bare stem prepared for actuator.
3/4"			MOV= Motor operated valve.
1"	1797F= SINGLE GLAND TYPE; CWP 200, SHORT PATTERN, WRENCH OPERATED, FLANGED RF ENDS.		POV= Pneumatic operated valve.
1 1/4"			LD= Locking device.
1 1/2"	1718F= REGULAR GLAND TYPE; CWP 200, SHORT PATTERN, WRENCH OPERATED, FLANGED RF ENDS.		SP= Special Paint.
2"			SPK= Special packing.
2 1/2"	1727F= REGULAR GLAND TYPE; CWP 200, SHORT PATTERN, WORM GEAR OPERATED, FLANGED RF ENDS.		XX= Additional requirements.
4"	1700= REGULAR GLAND TYPE; CWP 200, REGULAR PATTERN, WRENCH OPERATED, THREADED ENDS.		
5"			
6"	1700F= REGULAR GLAND TYPE; CWP 200, REGULAR PATTERN, WORM GEAR OPERATED, FLANGED RF ENDS.		
8"			
10"	1703F= REGULAR GLAND TYPE; CWP 175, VENTURI PATTERN, WORM GEAR OPERATED, FLANGED RF ENDS.		
12"			
14"	1707F= REGULAR GLAND TYPE; CWP 200, VENTURI PATTERN, WORM GEAR OPERATED, FLANGED RF ENDS.		
16"			
18"	2721F= CWP 500, VENTURI PATTERN, WRENCH OPERATED, FLANGED RF ENDS.		
	2723F= CWP 500, VENTURI PATTERN, WORM GEAR OPERATED, FLANGED RF ENDS.		

10" - 1796 - X

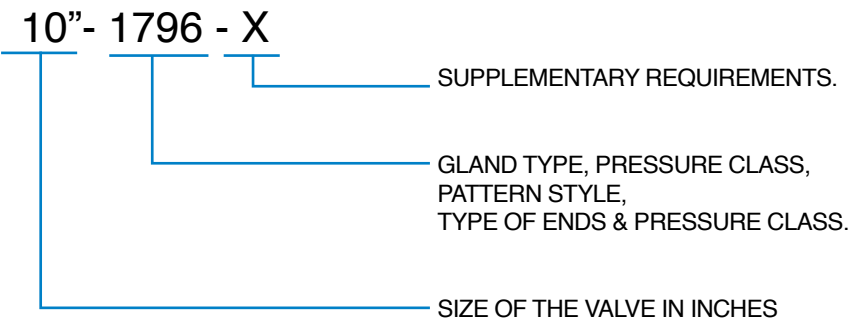

SUPPLEMENTARY REQUIREMENTS.

GLAND TYPE, PRESSURE CLASS, PATTERN STYLE, TYPE OF ENDS & PRESSURE CLASS.

SIZE OF THE VALVE IN INCHES

THE WALWORTH COMPANY GENERAL TERMS AND CONDITIONS

ACCEPTANCE: All quotations are for acceptance within 30 days from date of quotation unless extended in writing. In the event a purchase order is placed after this period of time, the WALWORTH Company reserves the right to requote base prices of all valves offered. All orders and contracts are subject to credit approval and acceptance by the WALWORTH Company.

FREIGHT: When prices are f.o.b. point of shipment - no freight allowance - we will attempt to route shipments in the method which will result in the lowest cost unless otherwise instructed. All shipments will be freight charges collect except when stipulated on the purchase order, in which case you will be invoiced for all transportation charges. Delivery of material to a common carrier shall be considered to be delivery to Buyer and shall be at Buyer's risk thereafter. Claims of loss of or damage to material in transit shall be filed by the Buyer directly with the carrier.

PRICES: There will be added to all prices quoted sales, use, occupation or any other excise or similar tax which Seller may be required to pay or collect on or in connection with the sale. Seller shall be established by Federal, State or other government regulation with respect to the product(s) topped by the order which shall be lower than the price(s) specified in the order.

ESCALATION TERMS: Prices shown in this price schedule reflect the costs in effect at the time of publication. These prices will remain firm on all products with a quoted delivery of twenty-six (26) weeks or less. On products which have a scheduled delivery of more than twenty-six (26) weeks, the goods will be invoiced based on the applicable price sheet in effect at the time of shipment. In no event will the invoiced price be less than the price originally quoted.

PURCHASED COMPONENTS: (i.e. motors, gearing, etc.) Prices are quoted on the supplier's price in effect at the time of quotation. Actual invoice price will be adjusted in accordance with the supplier's escalation policy.

DIFFERED SHIPMENTS: If for any reason the customer desires to delay shipments more than 30 days after manufacturing is complete, or to place a on hold or stop to the order during the manufacturing cycle, The WALWORTH Company reserves the right to consider the order cancelled and to invoke cancellation charges per the schedule below.

CANCELLATION: After order acceptance by WALWORTH, items or completed orders may be cancelled and Buyer will be charged for work performed, based on the following schedule:

- Five percent (5%) of prices of stock items.
- Ten percent (10%) of price of stock items ordered in quantities which exceed normal inventory levels.
- Five percent (5%) of prices prior to drawing submittal on made-to-order items.
- 15% after drawing approval, but prior to the start of castings.
- 30% to 50% during casting cycle, depending on the state of completion.
- 55% to 75% during machining and assembly operations, depending on the state of completion.
- 100% after final assembly and test.

REMITTANCES: Remittances must be made to the address indicated on the invoice.

CREDIT TERMS: As quoted. Invoices on balances overdue will be subject to a service charge of 1 1/2 % per month on such indebtedness.

DELIVERIES: Shipments and deliveries shall at all times be subject to the approval of Seller's Credit Department. If the Buyer shall fail to make any

payments according to the terms of the contract, Seller may, in addition to and not in limitation of its other rights and remedies, at its option, cancel all or any part of Buyer's incomplete contracts with Seller, or may defer shipments of deliveries under Buyer's contracts with Seller except upon receipt of satisfactory security or for cash shipment.

All schedule of shipments are estimated as closely as possible and Seller will use its best efforts to ship within the time scheduled, but does not guarantee to do so. Schedules commence with the date Seller receives authorization to proceed with the order, subject to the provisions of the next sentence. The order will not be released for manufacture until complete specifications and approved drawings (if drawing approval is required) are received at the plant of manufacturer and the estimated schedule of shipment will commence with the date of such receipt.

Seller shall not be liable for any direct, indirect or consequential damage or loss caused by any delay in delivery, regardless of the cause of delay.

Without limiting the generality of the foregoing, Seller assumes no responsibility for delays in delivery resulting from fire, flood, accidents, riots, strikes, transportation delays, labor or material shortages, existing or future laws, acts of any governmental authority, or any other cause beyond Seller's control. Items offered from stock are subject to prior sale.

INSPECTION: Final inspection and acceptance of products must be made at the plant of manufacture, unless otherwise provided in the order and/ or in agreed upon specifications. Prices do not include charges for special tests or inspections performed at the request of the Buyer, unless called for in the order and/or in agreed upon specifications.

RETURNS: Permission in writing and return tagging instructions must be obtained from Seller before any goods returned for credit or adjustment will be accepted. Where returned goods are accepted, a minimum charge of 25% of the invoice price will be made, plus freight from both directions and costs of reconditioning the material for resale as new.

WARRANTY: Seller will replace without charge or refund the purchase price of products manufactured by Seller which prove to be defective in the material or workmanship, provided in each case that the product is properly installed and is used in the service for which Seller recommends it and that a written claim, specifying the alleged defect, is presented to Seller. Seller shall in no event be responsible for (a) claims for labor, expenses or other damages occasioned by defective products or (b) for consequences or secondary damages. THE WARRANTY STATED IN THIS PARAGRAPH IS IN LIEU OF ALL OTHER WARRANTIES, EITHER EXPRESSED OR IMPLIED. WITH RESPECT TO WARRANTIES, THIS PARAGRAPH STATES BUYER'S EXCLUSIVE REMEDY AND SELLER'S EXCLUSIVE LIABILITY.

DESIGN, ETC: Seller reserves the right to change design, materials or specifications without notice. There will be a charge for modifying an order after it has been entered when such change or modification results in additional engineering or clerical work for either The WALWORTH Company or our suppliers.

MINIMUM CHARGE: Orders totaling less than \$100.00 net will be billed at a minimum charge of \$100.00. Repair parts will be billed at a minimum charge of \$50.00.

NOTE: We reserve the right to correct obvious clerical errors in quotations, invoices, and other contracts.



WALWORTH®

Since 1842



www.walworthvalves.com

MÉXICO

Industrial de Válvulas, S.A. de C.V.

Av. de la Industria Lote 16 Fracc. Industrial El Trébol, C.P. 54600 Tepetzotlán, Estado de México
Phone: (52 55) 5899 1700 Fax: (52 55) 5876 0156 | e-mail: info@walworth.com.mx

USA/CAN AUTHORIZED DISTRIBUTOR

TWC The Valve Company

13641 Dublin Court, Stafford, Texas 77477 | Phone: (281) 566 1200 Toll Free: (1 800) 697 1842 Fax: (281) 566 1299 |
www.twcvalves.com | e-mail: info@twcousa.com