



# Isuzu Truck Required Special Service Tool Inventory and New Dealer Set-Up Form

Please print or type clearly to avoid errors.

**1. Ordered By:**

Dealer Name \_\_\_\_\_ Dealer Code \_\_\_\_\_

Street Address \_\_\_\_\_

City \_\_\_\_\_ State \_\_\_\_\_ Zip Code \_\_\_\_\_ ext. \_\_\_\_\_

Phone Number where you can be reached during the day \_\_\_\_\_

**2. Ship To:** *(Only if different than ordered by).*

Name \_\_\_\_\_

Street Address \_\_\_\_\_

City \_\_\_\_\_ State \_\_\_\_\_ Zip Code \_\_\_\_\_

**3. Method of Payment:**

Check or Money Order  
\*Contact Bosch Automotive Service Solutions for Freight Charges

Isuzu Parts Account

Charge to Credit Card Below – Order Subject to Confirmation by Bosch Automotive Service Solutions

Check One

Visa  Mastercard  American Express Expiration Date \_\_\_\_\_

Enter Credit Card Number in boxes provided below

--	--	--	--	--	--	--	--	--	--	--	--	--	--	--	--	--	--	--	--	--	--	--	--	--	--	--	--

Last 3 Digits of Security Code (back of card) 

--	--	--

Authorized Credit Card Signature \_\_\_\_\_

**Products sold F.O.B. Shipping point**

To complete the special tool requirements for a new Dealer, please complete the following:

- For purchase of a complete Isuzu Truck Essential Tool Inventory
- For purchase of itemized tools, check tools desired in ORDER column of the inventory list

New dealer package	\$ _____
(Refer to spreadsheet for tool details)	\$ _____
	\$ _____
	\$ _____
Sales Tax	\$ _____
<small>State and local sales and/or use tax will be added to order if applicable Actual freight charges will be added to invoice.</small>	
Total	\$ _____

Dealer Authorized Signature \_\_\_\_\_

Printed Name of Signer \_\_\_\_\_

Date \_\_\_\_\_

*Essential tools are critical to proper vehicle diagnosis, service and repair. For this reason, Isuzu Truck's Dealer Sales and Service Agreement Standard Provisions require that Dealers obtain and maintain those tools identified by Isuzu Commercial Truck as essential. Before any tool is designated as essential, Isuzu Truck engineering determines the need for the tool, and works closely with Bosch Automotive Service Solutions to validate each tool's function on the applied make/model. Additionally, Isuzu Truck considers any commercially available tool options prior to every tool release. Actual tool costs are driven by timing requirements, design, materials selected, manufacturing process, and low tool production volumes. Each tool is maintained in Bosch inventory for over seven years after make/model end-of-production.*

**IMPORTANT!**







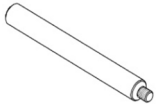

PLEASE FAX THIS SIGNED NEW DEALER SET-UP ORDER FORM TO 1-800-578-7375, ATTENTION: ACCOUNT SUPPORT REPRESENTATIVE.

OR IF YOU PREFER, SCAN A COPY OF THE SIGNED NEW DEALER SET-UP ORDER FORM AND SEND BY E-MAIL TO [KM@SERVICE-SOLUTIONS.COM](mailto:KM@SERVICE-SOLUTIONS.COM)

FAILURE TO FAX THIS SIGNED FORM TO THE CORRECT NUMBER WILL DELAY THE PROCESSING OF YOUR NEW DEALER KIT ORDER. PLEASE DIRECT ANY QUESTIONS TO AN ACCOUNT SUPPORT REPRESENTATIVE AT 1-800-328-6657.

# Isuzu Truck Required Special Service Tool Inventory and New Dealer Set-Up Form

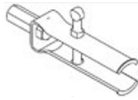
The following list contains the essential tools required for a new Isuzu Truck dealer. Please review the list below and contact Bosch Automotive Service Solutions with any questions regarding specific tools or equipment. The document can also be used as an inventory sheet for existing Isuzu Truck dealers.









Item	Tool Number/Description/Illustration	Group	On Hand	Order
1	<b>CH-37287-1A</b> Fuel Pressure Gauge Adapter 	EC		
2	<b>CH-50439</b> Kingpin Bushing Installer Handle 	SUS		
3	<b>CH-50440</b> Kingpin Bushing Installer 	SUS		
4	<b>CH-50441</b> Oil Seal Retainer Installer 	AXLE		
5	<b>CH-50442</b> Ball Joint Installer 	PROP		
6	<b>CH-50443</b> Dust Cover Installer 	PROP		
7	<b>CH-50444</b> Bearing Installer 	PROP		
8	<b>DT-46717</b> Rear Oil Seal Remover 	AT		
9	<b>DT-46718</b> Trans Cooler Filter By-Pass Adapter 	AT		
10	<b>DT-47668</b> Ring Gear Bolt Socket 	AXLE		

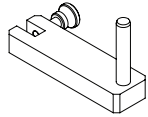



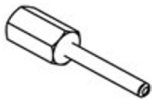
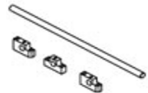

Item	Tool Number/Description/Illustration	Group	On Hand	Order
11	<b>DT-47715</b> Electrical Connector Passage Sleeve Remover/Installer 	AT		
12	<b>DT-47731</b> 1/2 Inch Quick Connect Release Tool 	AT		
13	<b>DT-47770</b> Seal Installer, Cooler Line 	AT		
14	<b>DT-47825</b> Control Solenoid Test Plate 	AT		
15	<b>DT-47848</b> Filter Neck Seal 	AT		
16	<b>DT-48021</b> Seal Installer, Output Shaft 	AT		
17	<b>DT-48285</b> Special Torx Socket 	AT		
18	<b>DT-50618-A</b> Wheel Speed Sensor Rotor Replacer 	BR		
19	<b>DT-51090</b> Rear Output Shaft Seal Remover 	AT		
20	<b>DT-51812</b> Range Switch Aligner 	AT		

### KEY TO GROUP CODES

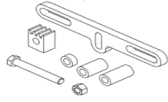
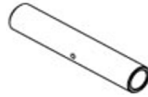
• AC - HVAC • AT - Automatic Transmission • AXLE - Rear Axle • BO - Body • BR - Brakes • COOL - Engine Cooling • EC - Engine Controls  
• EL - Electrical • EM - Engine Mechanical • GEN - General • MT - Manual Transmission • PROP - Propeller Shaft • STR - Steering • SUS - Suspension

# Isuzu Truck Required Special Service Tool Inventory and New Dealer Set-Up Form

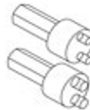

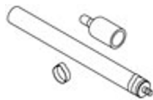
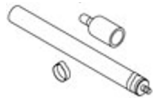





Item	Tool Number/Description/Illustration	Group	On Hand	Order
21	<b>DT-52743</b> Inhibitor Switch Adjuster 	AT		
22	<b>EL-35616-G</b> Connector Test Adapter Kit 	EC		
23	<b>EL-50928-A</b> DEF, DPF, and EFI Injector Tester 	EC		
24	<b>EN-46330</b> Timing Chain Tensioner Retaining Pin 	EM		
25	<b>EN-46719</b> Fuel Pressure Gauge Adapter 	EC		
26	<b>EN-46720</b> Injector Remover 	EM		
27	<b>EN-46721</b> Valve Spring Compressor Adapter 	EM		
28	<b>EN-46722</b> Compression Gauge Adapter 	EM		
29	<b>EN-47560</b> Fuel Pressure Gauge Adapter 	EC		
30	<b>EN-47667-A</b> Adapter Kit, Fuel Pressure Gauge 	EC		





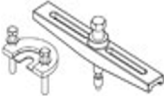

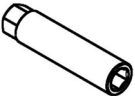
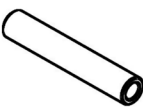

Item	Tool Number/Description/Illustration	Group	On Hand	Order
31	<b>EN-47680</b> Crankshaft Stopper 	EM		
32	<b>EN-47685</b> Valve Seal Installer 	EM		
33	<b>EN-47733</b> Storage Case, Fuel Pressure Gauge 	EC		
34	<b>EN-47909</b> Injector Bore Brush Kit 	EM		
35	<b>EN-47971</b> Oil Pressure Gauge Adapter 	EM		
36	<b>EN-48711</b> Wrench Kit, Tamper-Proof Bolt 	EC		
37	<b>EN-48853</b> Front Cover Aligner 	EM		
38	<b>EN-48974-15</b> EGR Cooler Tester Adapter Set, 17 mm 	EC		
39	<b>EN-48974-30</b> EGR Cooler Tester Adapter Set, 1" 	EC		
40	<b>EN-48974-5</b> EGR Cooler Tester Adapter Set, 5/8" 	EC		

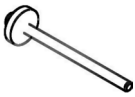
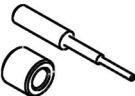
### KEY TO GROUP CODES

• AC - HVAC • AT - Automatic Transmission • AXLE - Rear Axle • BO - Body • BR - Brakes • COOL - Engine Cooling • EC - Engine Controls  
• EL - Electrical • EM - Engine Mechanical • GEN - General • MT - Manual Transmission • PROP - Propeller Shaft • STR - Steering • SUS - Suspension

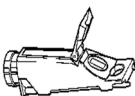
## Isuzu Truck Required Special Service Tool Inventory and New Dealer Set-Up Form

Item	Tool Number/Description/Illustration	Group	On Hand	Order
41	<b>EN-49102</b> Main Bearing Cap Remover 	EM		
42	<b>EN-49245</b> Injector Seal Installer and Sizer 	EC		
43	<b>EN-49248</b> Injector Rail Assembly Remover (Two sets of EN-49248 are required) 	EM		
44	<b>EN-49756</b> Pulley Installer, Vacuum Pump 	EM		
45	<b>EN-49792</b> Pulley Remover, Vacuum Pump 	EM		
46	<b>EN-49960</b> Replacer, Injector Nozzle Sleeve 	EM		
47	<b>EN-50191</b> Fuel Filter Housing Wrench 	EC		
48	<b>EN-50343</b> DPF Opening Gauge 	EC		
49	<b>EN-50345</b> Wrench, Valve Clearance Adjust Nut 	EM		
50	<b>EN-50346</b> Installer, Valve Stem Seal 	EM		









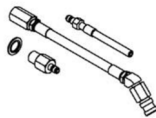

Item	Tool Number/Description/Illustration	Group	On Hand	Order
51	<b>EN-50347</b> Installer, Injection Pipe Oil Seal 	EM		
52	<b>EN-50348</b> Replacer, Valve Guide 	EM		
53	<b>EN-50349</b> Oil Seal Installer Adapter (Front Crankshaft) 	EM		
54	<b>EN-50351</b> Installer, Rear Oil Seal 	EM		
55	<b>EN-50421</b> Engine Rear Hanger 	EM		
56	<b>EN-50422</b> Refractometer, DEF 	EC		
57	<b>EN-50424</b> Engine Lift Bracket 	EM		
58	<b>EN-50490</b> Valve Guide Installer 	EM		
59	<b>EN-50547</b> Injector Remover 	EM		
60	<b>EN-50611</b> Installer, Front Crankshaft Seal 	EM		

### KEY TO GROUP CODES

• AC - HVAC • AT - Automatic Transmission • AXLE - Rear Axle • BO - Body • BR - Brakes • COOL - Engine Cooling • EC - Engine Controls  
• EL - Electrical • EM - Engine Mechanical • GEN - General • MT - Manual Transmission • PROP - Propeller Shaft • STR - Steering • SUS - Suspension

## Isuzu Truck Required Special Service Tool Inventory and New Dealer Set-Up Form

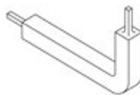







Item	Tool Number/Description/Illustration	Group	On Hand	Order
61	<b>EN-50613</b> Injector Remover 	EM		
62	<b>EN-50720</b> Engine Guide Bracket 	EM		
63	<b>EN-50746</b> Scissors Gear Retaining Pins 	EM		
64	<b>EN-51092</b> Fuel Pump Installation Gauge 	EM		
65	<b>EN-51096</b> Rear Main Seal Remover 	EM		
66	<b>EN-51097</b> Injector Retaining Clip Installer 	EM		
67	<b>EN-51105</b> Injector Seal Installer Adapters 	EC		
68	<b>EN-51212</b> Torque Adapter 	EM		
69	<b>EN-51246</b> Engine Lift Bracket 	EM		
70	<b>EN-51510</b> Slinger Remover 	EM		







Item	Tool Number/Description/Illustration	Group	On Hand	Order
71	<b>EN-51613</b> DEF Injector Regen Block-Off Plate 	EC		
72	<b>EN-51614</b> DPF Injector Test Adapters 	EC		
73	<b>EN-51952</b> Compression Gauge Adapter 	EM		
74	<b>EN-52575</b> DEF Injector Cleaner 	EC		
75	<b>EN-52575-50</b> DEF Injector Cleaner Accessory Kit 	EC		
76	<b>EN-52585</b> TRAX 3 Fuel Diagnostic Module 	EC		
77	<b>EN-52793</b> Front Crankshaft Seal Installer 	EM		
78	<b>GE-47716</b> Coolant Fill System 	COOL		
79	<b>GE-48717</b> Nozzle Adjuster, Windshield Washer 	BO		
80	<b>J-21867-A</b> Engine/Transmission Oil Pressure Gauge 	AT		

### KEY TO GROUP CODES

• AC - HVAC • AT - Automatic Transmission • AXLE - Rear Axle • BO - Body • BR - Brakes • COOL - Engine Cooling • EC - Engine Controls  
• EL - Electrical • EM - Engine Mechanical • GEN - General • MT - Manual Transmission • PROP - Propeller Shaft • STR - Steering • SUS - Suspension

## Isuzu Truck Required Special Service Tool Inventory and New Dealer Set-Up Form

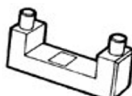
Item	Tool Number/Description/Illustration	Group	On Hand	Order
81	<b>J-22873</b> Rear Output Shaft Seal Installer 	AT		
82	<b>J-23498-A</b> Driveline Inclinometer 	PROP		
83	<b>J-24460-A</b> Cooling System Pressure Tester 	COOL		
84	<b>J-26999</b> Compression Gauge, Diesel, 1000 psi (Includes J-26999-12) 	EM		
85	<b>J-26999-10</b> Compression Gauge Adapter 	EM		
86	<b>J-26999-20</b> Compression Gauge Adapter 	EM		
87	<b>J-26999-30</b> Compression Gauge Adapter 	EM		
88	<b>J-33984-A</b> Coolant Pressure Tester Adapters 	COOL		
89	<b>J-34532</b> Compression Gauge Adapter 	EM		

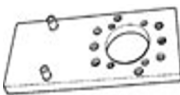







Item	Tool Number/Description/Illustration	Group	On Hand	Order
90	<b>J-34539</b> Adapter, King Pin/ Idler Shaft 	SUS		
91	<b>J-34730-14</b> Fuel Pressure Gauge Extension Hose 	EC		
92	<b>J-34730-1A</b> Fuel Pressure Gauge 	EC		
93	<b>J-34730-405</b> Injector Test Lamp 	EC		
94	<b>J-35008</b> Rear Hub Inner Bearing Cup Installer (292mm Differential) 	AXLE		
95	<b>J-35012</b> Rear Hub Bearing Nut Wrench 	AXLE		
96	<b>J-35013</b> Rear Hub Remover 	AXLE		
97	<b>J-35014</b> Pinion Cage Seal Installer (292mm Differential) 	AXLE		
98	<b>J-35016-B</b> Drive Pinion Flange Bracket 	AXLE		

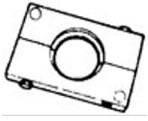







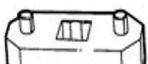

### KEY TO GROUP CODES

• AC - HVAC • AT - Automatic Transmission • AXLE - Rear Axle • BO - Body • BR - Brakes • COOL - Engine Cooling • EC - Engine Controls  
• EL - Electrical • EM - Engine Mechanical • GEN - General • MT - Manual Transmission • PROP - Propeller Shaft • STR - Steering • SUS - Suspension

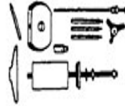

# Isuzu Truck Required Special Service Tool Inventory and New Dealer Set-Up Form









Item	Tool Number/Description/Illustration	Group	On Hand	Order
99	<b>J-35018</b> Pinion Bearing Remover 	AXLE		
100	<b>J-35019</b> Rear Hub Outer Bearing Installer 	AXLE		
101	<b>J-35020</b> Pinion Bearing Cup Installer (292mm Differential) 	AXLE		
102	<b>J-35021</b> Differential Side Bearing Installer 	AXLE		
103	<b>J-35030</b> Differential Side Bearing Puller Pilot 	AXLE		
104	<b>J-35689-A</b> Metri-Pack Terminal Remover 	EL		
105	<b>J-35712</b> Front Hub Inner Bearing Cup Installer 	SUS		
106	<b>J-35713</b> Front Hub Outer Bearing Cup Installer 	SUS		
107	<b>J-35717</b> Steering Shaft Socket 	STR		
108	<b>J-35767</b> Power Steering Lockout Wrench 	STR		







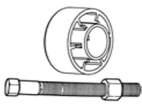
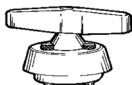

Item	Tool Number/Description/Illustration	Group	On Hand	Order
109	<b>J-35944-18</b> Flusher Adapters 	AT		
110	<b>J-36022</b> Air Line Adapter 	EM		
111	<b>J-36408</b> Kingpin Inner Bearing Installer 	SUS		
112	<b>J-36409</b> Kingpin Outer Bearing Installer 	SUS		
113	<b>J-36410</b> Kingpin Bearing Remover 	SUS		
114	<b>J-36429-A</b> Hub Remover 	SUS		
115	<b>J-36520-B</b> Cylinder Liner Remover and Installer (Includes J-37365) 	EM		
116	<b>J-37228</b> Oil Pan Seal Cutter 	AT		
117	<b>J-37420</b> Steering Knuckle Service Set 	SUS		
118	<b>J-38821</b> Valve Spring Compressor Adapter 	EM		

### KEY TO GROUP CODES

• AC - HVAC • AT - Automatic Transmission • AXLE - Rear Axle • BO - Body • BR - Brakes • COOL - Engine Cooling • EC - Engine Controls  
• EL - Electrical • EM - Engine Mechanical • GEN - General • MT - Manual Transmission • PROP - Propeller Shaft • STR - Steering • SUS - Suspension

## Isuzu Truck Required Special Service Tool Inventory and New Dealer Set-Up Form

Item	Tool Number/Description/Illustration	Group	On Hand	Order
119	<b>J-39114-C</b> Rear Hub Seal Installer (292mm Differential) 	AXLE		
120	<b>J-39758</b> King Pin Holding Tool 	SUS		
121	<b>J-41107</b> Oil Seal Installer 	AXLE		
122	<b>J-41220</b> Oil Slinger Remover 	EM		
123	<b>J-41221-A</b> Oil Seal Installer 	EM		
124	<b>J-41222</b> Crankshaft Gear Installer 	EM		
125	<b>J-41223</b> Valve Stem Seal Installer 	EM		
126	<b>J-41268</b> Slinger Assembly Replacer 	EM		
127	<b>J-41347</b> Engine Stand Adapter 	EM		









Item	Tool Number/Description/Illustration	Group	On Hand	Order
128	<b>J-41478-A</b> Front Oil Seal Installer 	EM		
129	<b>J-41479-B</b> Rear Oil Seal Installer 	EM		
130	<b>J-41479-10</b> Rear Crankshaft Seal Installer Adapter 	EM		
131	<b>J-41480-A</b> Front/Rear Cover Aligner 	EM		
132	<b>J-41556</b> Connecting Rod Guides 	EM		
133	<b>J-41558</b> Crankshaft Sprocket Remover 	EM		
134	<b>J-41665-A</b> Balancer/Sprocket Installer 	EM		
135	<b>J-41712</b> Oil Pressure Switch Socket 	EM		
136	<b>J-41736</b> Rear Oil Seal/Bearing Installer 			

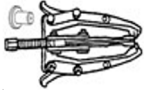





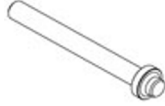

### KEY TO GROUP CODES

• AC - HVAC • AT - Automatic Transmission • AXLE - Rear Axle • BO - Body • BR - Brakes • COOL - Engine Cooling • EC - Engine Controls  
• EL - Electrical • EM - Engine Mechanical • GEN - General • MT - Manual Transmission • PROP - Propeller Shaft • STR - Steering • SUS - Suspension



## Isuzu Truck Required Special Service Tool Inventory and New Dealer Set-Up Form









Item	Tool Number/Description/Illustration	Group	On Hand	Order
137	<b>J-41769</b> Fuel Line Release Tools 	EC		
138	<b>J-41816</b> Crankshaft Balancer Remover 	EM		
139	<b>J-42183</b> Short Driver Handle 	AT		
140	<b>J-42206</b> Dual Air Pressure Gauge 	BR		
141	<b>J-42206-50</b> Air Pressure Gauge Adapter 	BR		
142	<b>J-42401-A</b> Radiator Pressure Test Adapters 	COOL		
143	<b>J-42907</b> Oil Pressure Tester 	EM		
144	<b>J-43267</b> Valve Stem Seal Installer 	EM		
145	<b>J-43268-A</b> Guide Bridge Installer 	EM		







Item	Tool Number/Description/Illustration	Group	On Hand	Order
146	<b>J-43269</b> Injection Pipe Seal Installer 	EM		
147	<b>J-43282</b> Front Oil Seal Replacer 	EM		
148	<b>J-43283</b> Valve Guide Remover and Installer 	EM		
149	<b>J-43285</b> Slinger Puller 	EM		
150	<b>J-43680-A</b> Engine Stand Adapter 	EM		
151	<b>J-44203-A</b> Compression Gauge Adapter 	EM		
152	<b>J-44275</b> Hi-Shear Wheel Bearing Nut Socket 	AXLE		
153	<b>J-44276</b> Hi-Shear Wheel Bearing Nut Socket 	AXLE		
154	<b>J-44581</b> Fuel Line Release Tool 	EC		

### KEY TO GROUP CODES

• AC - HVAC • AT - Automatic Transmission • AXLE - Rear Axle • BO - Body • BR - Brakes • COOL - Engine Cooling • EC - Engine Controls  
• EL - Electrical • EM - Engine Mechanical • GEN - General • MT - Manual Transmission • PROP - Propeller Shaft • STR - Steering • SUS - Suspension

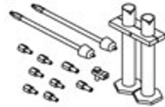
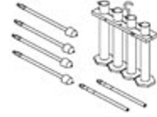
## Isuzu Truck Required Special Service Tool Inventory and New Dealer Set-Up Form

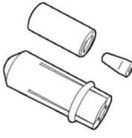
Item	Tool Number/Description/Illustration	Group	On Hand	Order
155	<b>J-44619</b> Hi-Shear Wheel Bearing Nut Socket 	AXLE		
156	<b>J-44638</b> Vacuum/Pressure Gauge 	EC		
157	<b>J-45000</b> Seal Remover 	AT		
158	<b>J-45004-1</b> Fuel Siphon Hose 	EC		
159	<b>J-45059-A</b> Torque Angle Meter 	EM		
160	<b>J-45201</b> Seal Remover, Oil Cooler Line 	AT		
161	<b>J-45270</b> Wheel Stud Remover 	AXLE		
162	<b>J-45275</b> Manifold Air Line Release Tool 	BR		
163	<b>J-45299</b> Engine Pre-Luber 	EM		

Item	Tool Number/Description/Illustration	Group	On Hand	Order
164	<b>J-45666</b> Air Line Release Tool 	BR		
165	<b>J-45722</b> Fuel Sending Unit Lock Ring Wrench 	EC		
166	<b>J-45873</b> Fuel Return Volume Hoses 	EC		
167	<b>J-45873-100</b> Fuel Return Volume Hose Adapters 	EC		
168	<b>J-45997</b> Torque Adapter (30mm Crowfoot) 	BR		
169	<b>J-46091</b> Inner Cooler Pressure Tester 	EC		
170	<b>J-46911</b> Injector Seal Installer and Sizer 	EC		
171	<b>J-8092</b> Driver Handle 	GEN		
172	<b>95-0070</b> EVAP System Tester 	EC		

### KEY TO GROUP CODES

• AC - HVAC • AT - Automatic Transmission • AXLE - Rear Axle • BO - Body • BR - Brakes • COOL - Engine Cooling • EC - Engine Controls  
• EL - Electrical • EM - Engine Mechanical • GEN - General • MT - Manual Transmission • PROP - Propeller Shaft • STR - Steering • SUS - Suspension