

# ITM 218 – Experience the Value of Requirements to Deploy in SAP Solution Manager 7.2

# Speakers

---

Las Vegas, Oct 19 - 23

- Tim Steuer

Barcelona, Nov 10 - 12

- Tim Steuer



# Disclaimer

---

This presentation outlines our general product direction and should not be relied on in making a purchase decision. This presentation is not subject to your license agreement or any other agreement with SAP. SAP has no obligation to pursue any course of business outlined in this presentation or to develop or release any functionality mentioned in this presentation. This presentation and SAP's strategy and possible future developments are subject to change and may be changed by SAP at any time for any reason without notice. This document is provided without a warranty of any kind, either express or implied, including but not limited to, the implied warranties of merchantability, fitness for a particular purpose, or non-infringement. SAP assumes no responsibility for errors or omissions in this document, except if such damages were caused by SAP intentionally or grossly negligent.

# Agenda

---

## **SAP Solution Manager 7.2 innovation at a glance**

- **Release Management**
- **Requirement Management**
- **Process Management**

# SAP Solution Manager

Overview

# Your Challenges in Managing an IT Environment

Growing demand and pressure to support business demand

To stay **agile and competitive** you have to meet changing or **growing business requirements**. You need to invest into new functionalities and enhanced capabilities.

## Request of new business functions

The business is requesting more functionalities and new capabilities from IT because of growing or ever changing business requirements. Maintain business continuity and enable innovation.



CIO

## Keep the systems running

You need to manage a complex and growing or changing IT environment plus leverage best practices for application lifecycle management (ALM).

## Utilize new technologies

To leverage the full potential of your SAP engagement you follow our newest technology in order to speed up processes and stay ahead of competitors.

# SAP Solution Manager

The centerpiece of your support engagement



Maximize the value of your support engagement with SAP Solution Manager.

## Enable Business Innovation



Detect and realize improvement potentials of your business processes and implement new business models to gain competitive advantage.

Access to SAP experts...

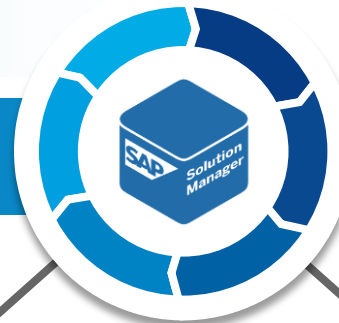

...and support services.

## Improve IT Management



ITIL-aligned IT Service Management and ALM Processes to manage SAP and non-SAP components plus proven methodologies.

## SAP Solution Manager

## Leverage SAP Innovations



Implement and manage SAP innovations like SAP HANA, mobile solutions or hybrid IT landscapes and leverage the full potential of your SAP partnership.

# SAP Solution Manager 7.2:

## Get more out of your SAP investment

Simpler Business / IT Alignment  
with new Process Management

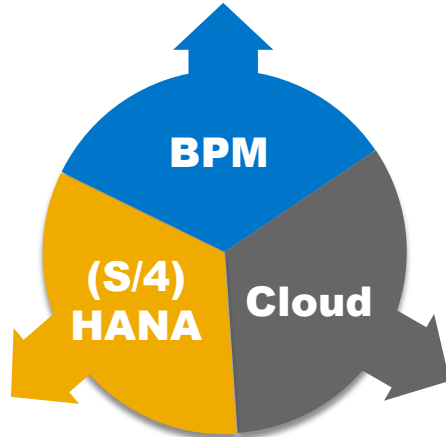

Full Support of HANA  
and S/4 HANA

Full Support of  
SAP Hybrid Solutions

**SAP Solution Manager 7.2 powers implementation and eases communication with the business**

**SAP Solution Manager 7.2 continues focus on operations and on IT**

### Highlights of the new release:

- Process Management
- Business value through SAP Cloud adoption
- More SAP Solution Manager value through in-memory technology

This is the current state of planning and may be changed by SAP at any time.



# SAP Solution Manager

## Product description

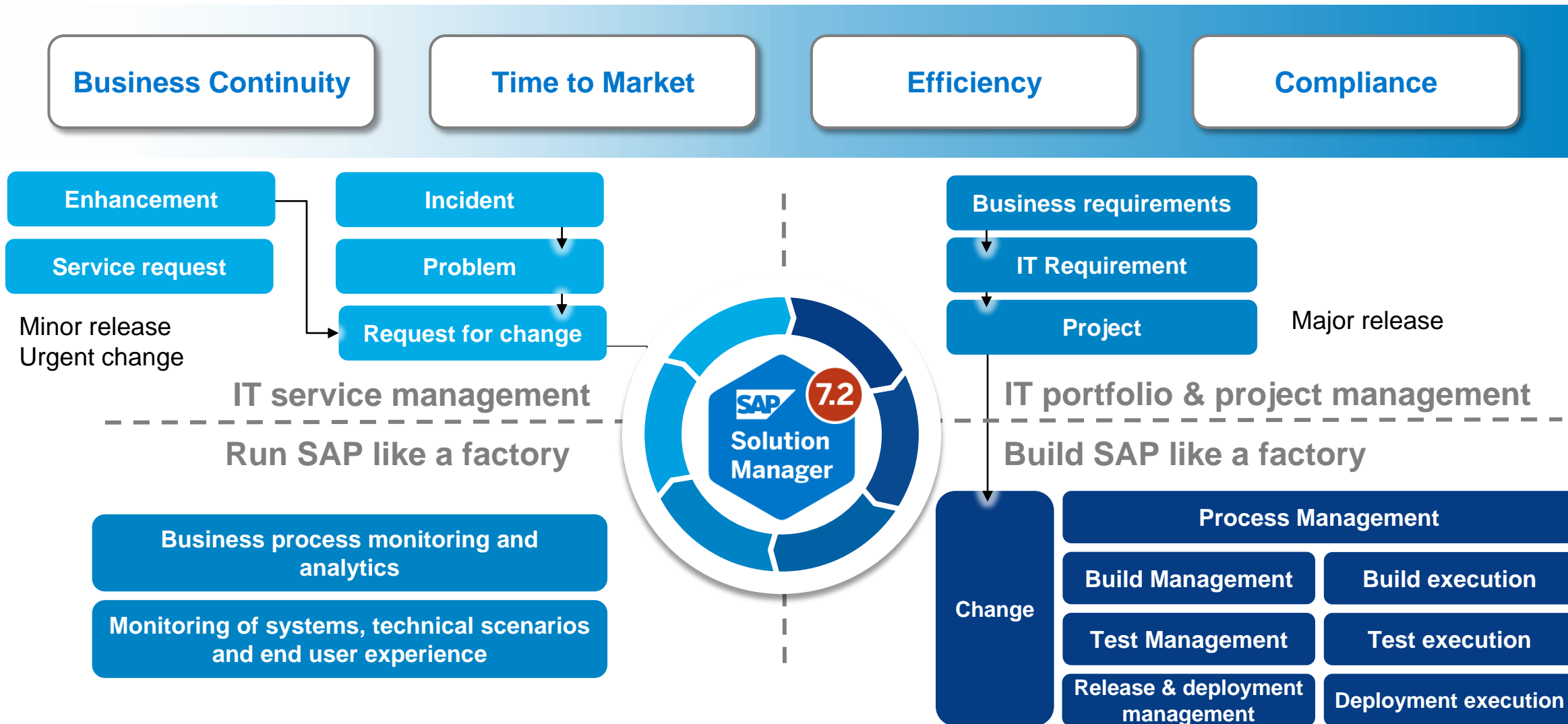

This is the current state of planning and may be changed by SAP at any time.

# Release Management

# The 3-step approach for release management in Solution Manager

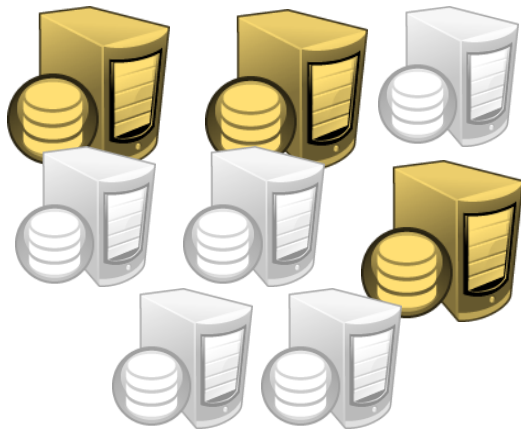

System Landscape

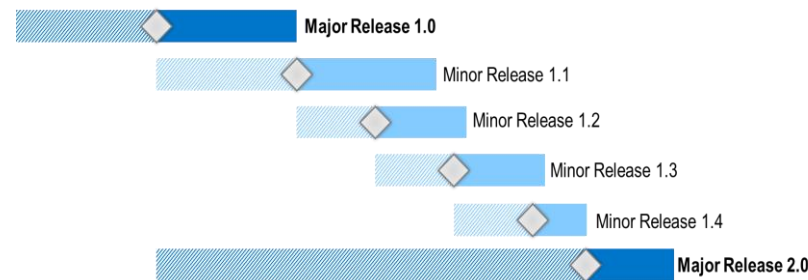

Durations & Go-Live Date

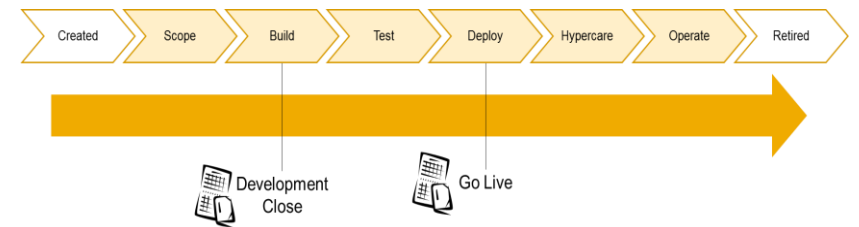

Assign Change Documents & Manage Release Deployment

This is the current state of planning and may be changed by SAP at any time.

# SAP Solution Manager 7.2

## Introduction to release management

**Release & Deployment Management** is essential to manage successful deployment of all related changes into the productive environment.

**Release Management** defines dates and schedule for Releases.

**Release** content is determined by Projects, Requests for Changes, and related Change Documents.

The **Release Cycle** is a technical container and model for the release content.

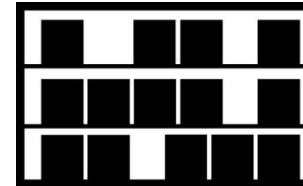
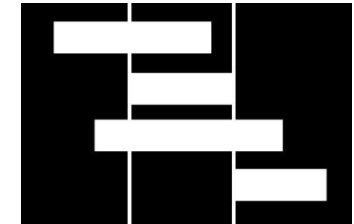

This is the current state of planning and may be changed by SAP at any time.

# Do your projects go live whenever they are ready?

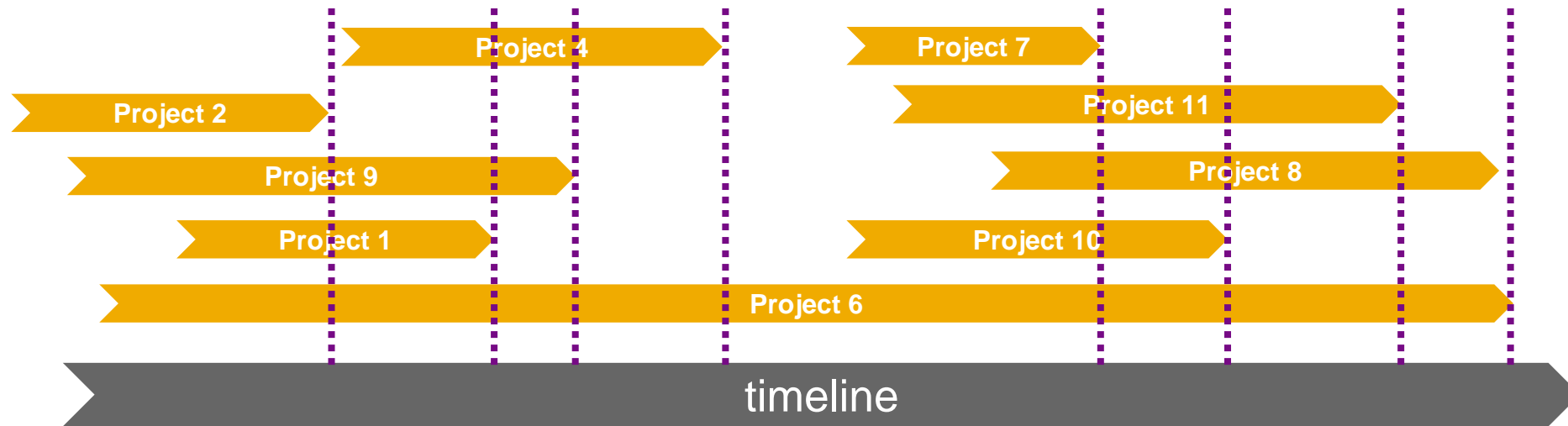

**This means that you may have ...**

- ❑ A hard time to ensure proper & complete testing
- ❑ High effort taking care of conflicts & dependencies
- ❑ Many manual steps and activities during Go-Live
- ❑ No routine procedure for go-live situations
- ❑ Trouble keeping your IT Services running
- ❑ ...

# Releases synchronize projects and help to keep the control

## Reduce Risk, Simplify Go-Live Process and Decrease Test Effort

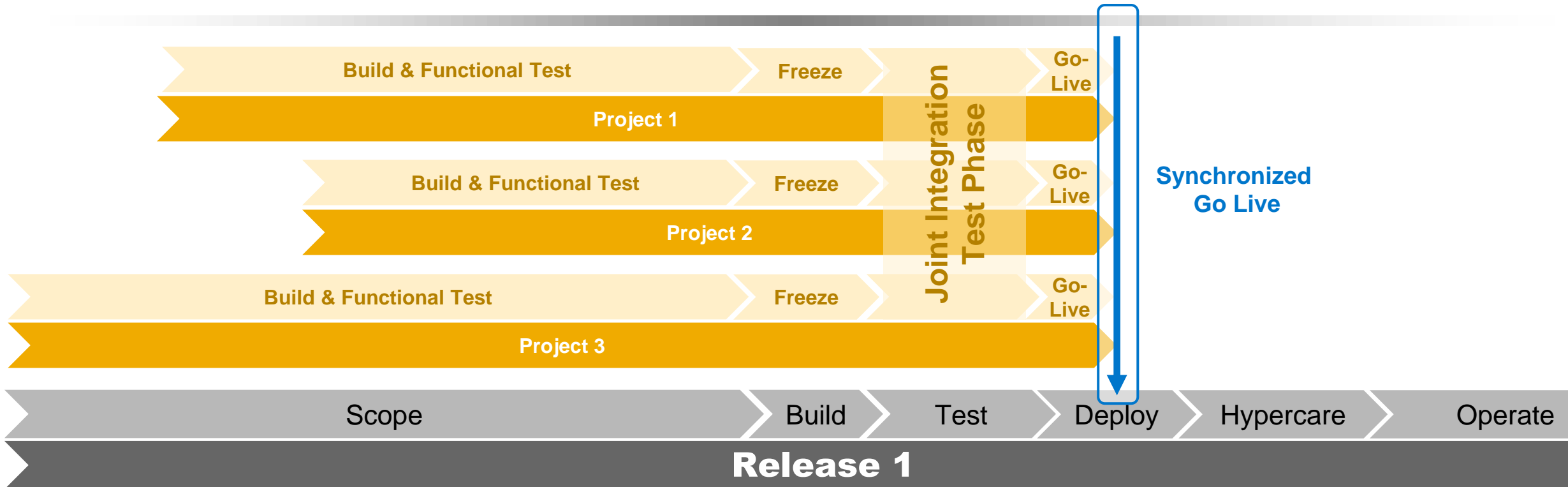

This is the current state of planning and may be changed by SAP at any time.

# Release Management – Major and minor releases

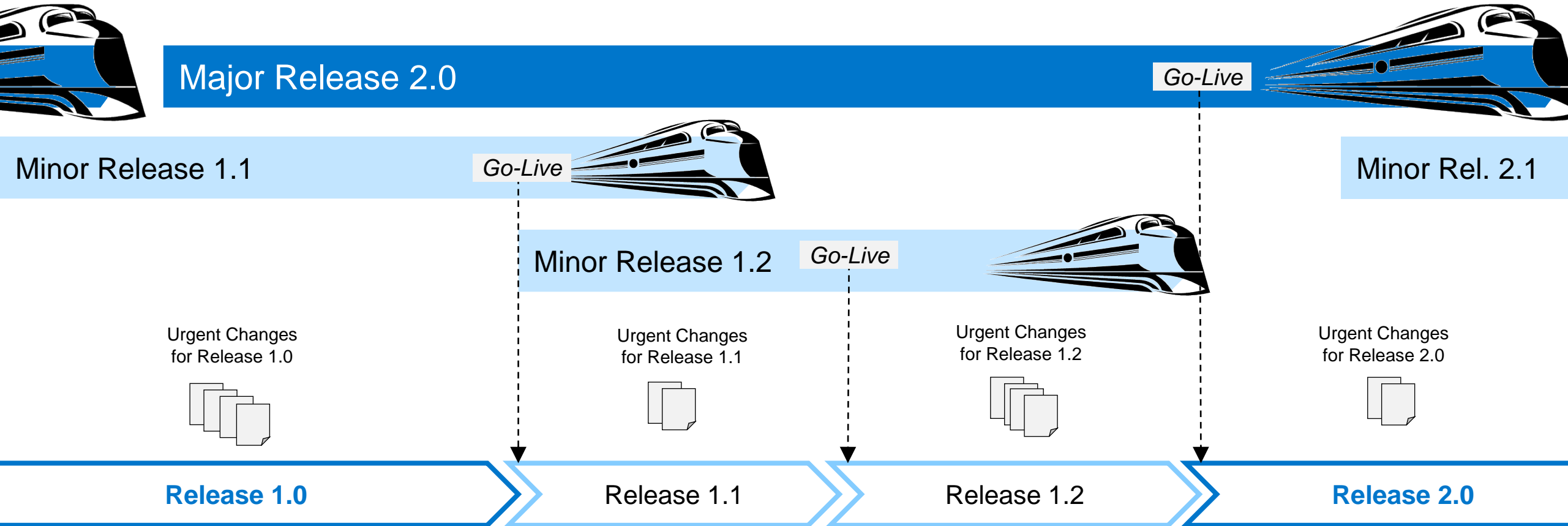

This is the current state of planning and may be changed by SAP at any time.

# Integrated requirements to deploy process for business and IT

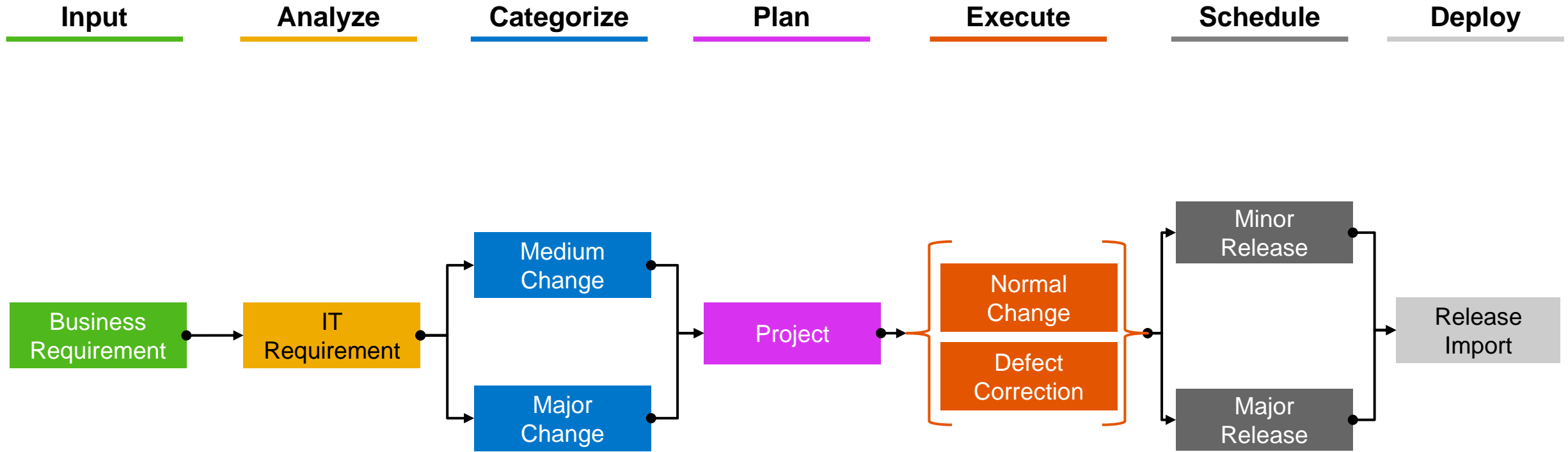

This is the current state of planning and may be changed by SAP at any time.



# SAP Solution Manager 7.2

Solution Documentation integrated with Project-, Change- & Release Management

PLAN

DESIGN

BUILD

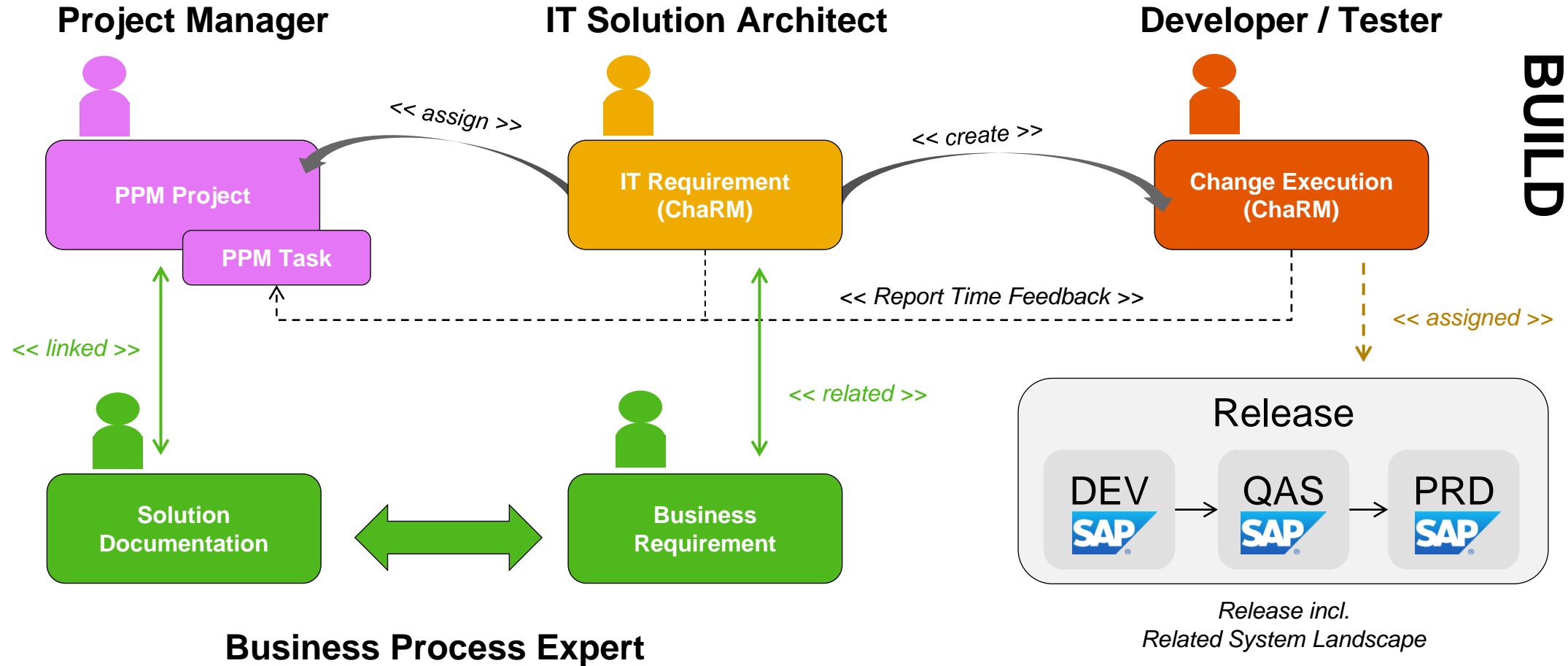

This is the current state of planning and may be changed by SAP at any time.

# Demo

Release Management

# SAP Solution Manager 7.2

## Integrated and guided release planning application

SAP Labs Preview

The screenshot displays the SAP Solution Manager 7.2 interface for release planning. On the left, a dialog box titled 'Neue Releases anlegen' (Create New Releases) is open, allowing users to configure release parameters. The dialog is split into 'Major-Release' and 'Minor-Release' sections. The 'Change-Control-Landschaft' is set to 'AT\_RT\_72\_CHARM\_TEST\_SUB\_1'. The 'Major-Release' section includes fields for 'Zahl' (1), 'Dauer (Tage)' (130), 'Branch' (Pseudo Maint-Site Branch 3 - dead end), and 'Tag des Produktivstarts' (Sonntag). The 'Minor-Release' section includes fields for 'Anzahl der Minor-Releases' (1), 'Dauer (Tage)' (60), 'Branch' (Pseudo Maint-Site Branch 3 - dead end), and 'Tag des Produktivstarts' (Sonntag). A calendar widget shows the date '2' selected in September 2015.

In the background, the 'Service Management' overview is visible, showing a table of release activities and a Gantt chart. The table lists release activities with columns for Status, Go-Live, Branch, Release-Zyklus, and a timeline from 2015 to 2017. The Gantt chart visualizes the release schedule, showing major releases (e.g., Major Release 5.0.0, 6.0.0, 7.0.0, 8.0.0, 9.0.0, 10.0.0) and minor releases (e.g., Minor Release 7.1.0, 7.2.0, 7.3.0, 7.4.0, 8.1.0, 9.1.0, 9.2.0, 10.1.0, 10.2.0, 10.3.0, 11.1.0) across different quarters and years.

Release ID	Status	Go-Live	Branch	Release-Zyklus
16	Build	28/08/2015	Maintenance	MIT_ST720SP1 Sawy
17	Build	02/09/2015	Maintenance	AT_RT_72_CHARM...
18	Planned	09/10/2015	Maintenance	AT_RT_72_CHARM...
19	Planned	01/12/2015	Maintenance	AT_RT_72_CHARM...
20	Planned	13/03/2016	Development	AT_RT_72_CHARM...
21	Planned	01/08/2016	Development	AT_RT_72_CHARM...
22	Build	22/08/2016	Development	AT_RT_72_CHARM...
23	Build	12/09/2016	Development	AT_RT_72_CHARM...
24	Build	03/10/2016	Development	CC MIT
25	Build	24/10/2016	Development	AT_RT_72_CHARM...
26	Planned	17/11/2016	Development	
27	Planned	02/12/2016	Maintenance	AT_RT_72_CHARM...
28	Planned	01/01/2017	Development	
29	Planned	29/01/2017	Maintenance	
30	Planned	26/02/2017	Maintenance	
31	Planned	02/04/2017	Development	
32	Planned	30/04/2017	Maintenance	
33	Planned	28/05/2017	Maintenance	
34	Planned	25/06/2017	Maintenance	
35	Planned	02/07/2017	Development	
36	Planned	30/07/2017	Maintenance	
37	Planned	27/08/2017	Maintenance	

This is the current state of planning and may be changed by SAP at any time.

# SAP Solution Manager 7.2

## Manage release cycles via the Administration Cockpit

SAP Labs Preview

The screenshot displays the SAP Solution Manager 7.2 Administration Cockpit interface. The main window is titled 'Task List Overview' and shows a table of tasks under the 'Release Cycles' tab. A dialog box titled 'Import Transport Requests' is open, showing a list of transport requests and an 'Import Date' section with options for 'Immediately' or 'At Start Time'.

**Task List Overview (Left Window):**

Task List	Description	Status	Cycle	Phase	Development System	Production System
R00000528	Cycle switch	!		Created	MW5-ABAP/100	MW5-ABAP/300
R00000709						

**Import Transport Requests Dialog:**

Source System: MW5-ABAP/100 | Target System: MW5-ABAP/200 (Quality Assurance System)

Transport	Owner	Description	Type
MW5K937987	QGM_ALL_01	MW5K937672 : Generated test transport	
MW5K937986	CAOCH	MW5K900251 : Generated test transport	
MW5K937985	QGM_ALL_01	MW5K937672 : Generated test transport	
MW5K937984	LONGGU	MW5K900320 : Generated test transport	
MW5K937983	LONGGU	MW5K900320 : Generated test transport	

**Task List Overview (Right Window):**

Task List	Description	Status	Cycle	Phase	Development System	Production System	Created by	Created On	Variant
R00000709		!		Scope	A12-ABAP/001	A24-ABAP/300	JIANGER	28.09.2014	SAP0
R00000528	Cycle switch	!		Created	MW5-ABAP/100	MW5-ABAP/300	JIANGER	01.07.2014	SAP0

**Landscape Graphic:**

The landscape graphic shows a flow of transport requests between systems:

- Development System (MW5:100):** No risks, No conflicts.
- Quality Assurance System (MW5:200):** 5 Missing Synchronization, 2 Overtake Warning, DGP Status: No conflicts.
- Pre-Production System (MW5:215):** 3 Missing Synchronization, 3 Imminent Downgrade, DGP Status: No conflicts.
- Production System (MW5:300):** No risks, No conflicts.
- Development System (MW4:100):** No risks, No conflicts.
- Quality Assurance System (MW4:200):** No risks, No conflicts.
- Pre-Production System (MW4:300):** 8 Missing Synchronization, 1 Downgrade, DGP Status: No conflicts.
- Production System (MW4:400):** No risks, No conflicts.
- Development System (J01):** Manual Refresh needed, DGP Status: Disabled.
- Quality Assurance System (J02):** Manual Refresh needed, DGP Status: Disabled.
- Production System (D01):** Manual Refresh needed, DGP Status: Disabled.

This is the current state of planning and may be changed by SAP at any time.

# Requirement Management

# Managing requirements

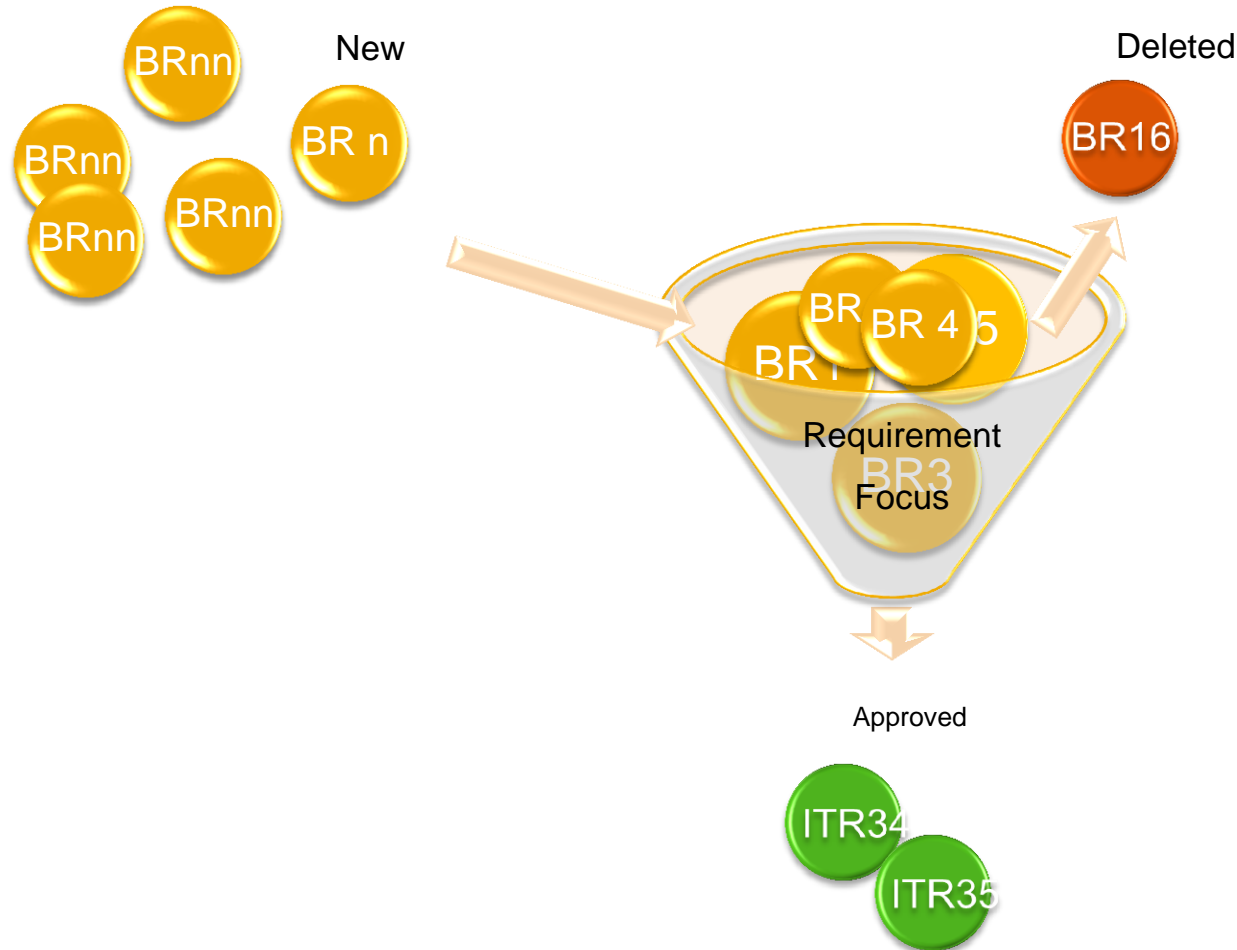

**Business Expert  
and  
Business Manager**



**Release Manager  
and  
Change Manager**

This is the current state of planning and may be changed by SAP at any time.

# From business requirement to release

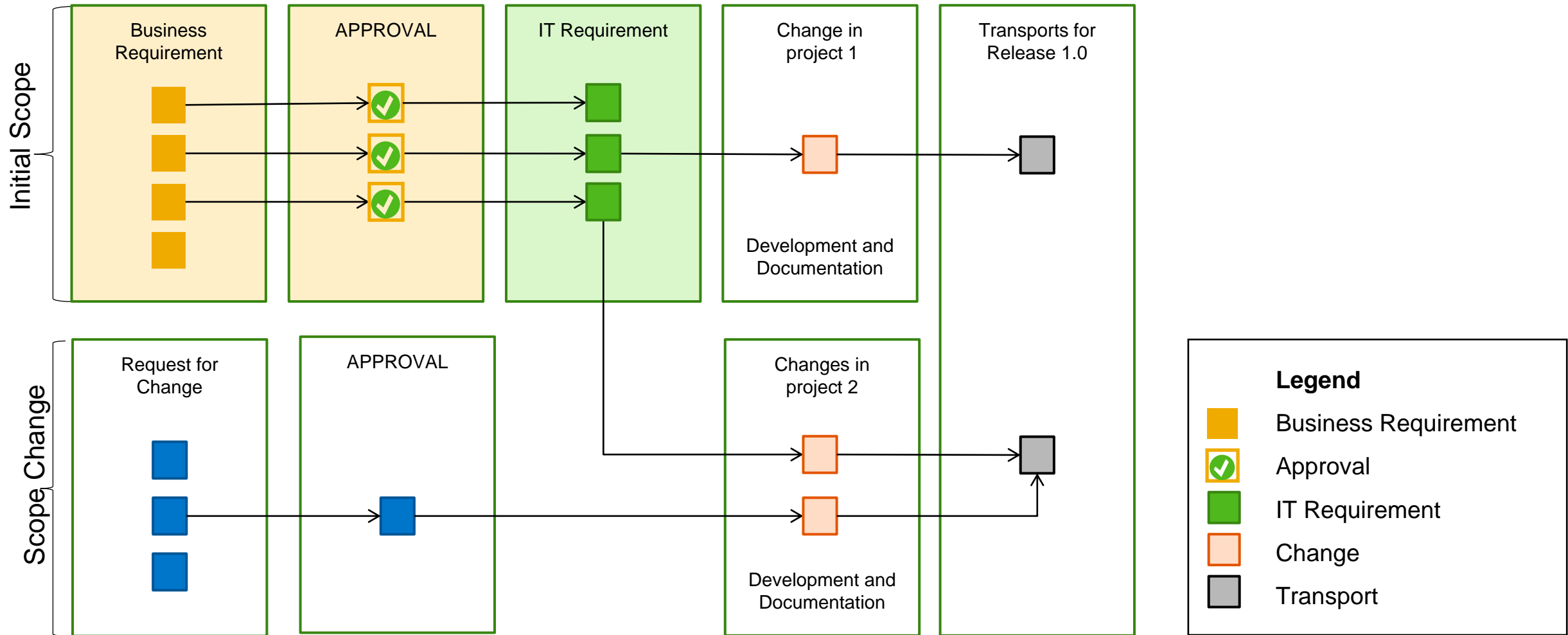

This is the current state of planning and may be changed by SAP at any time.

# Release Management structures projects

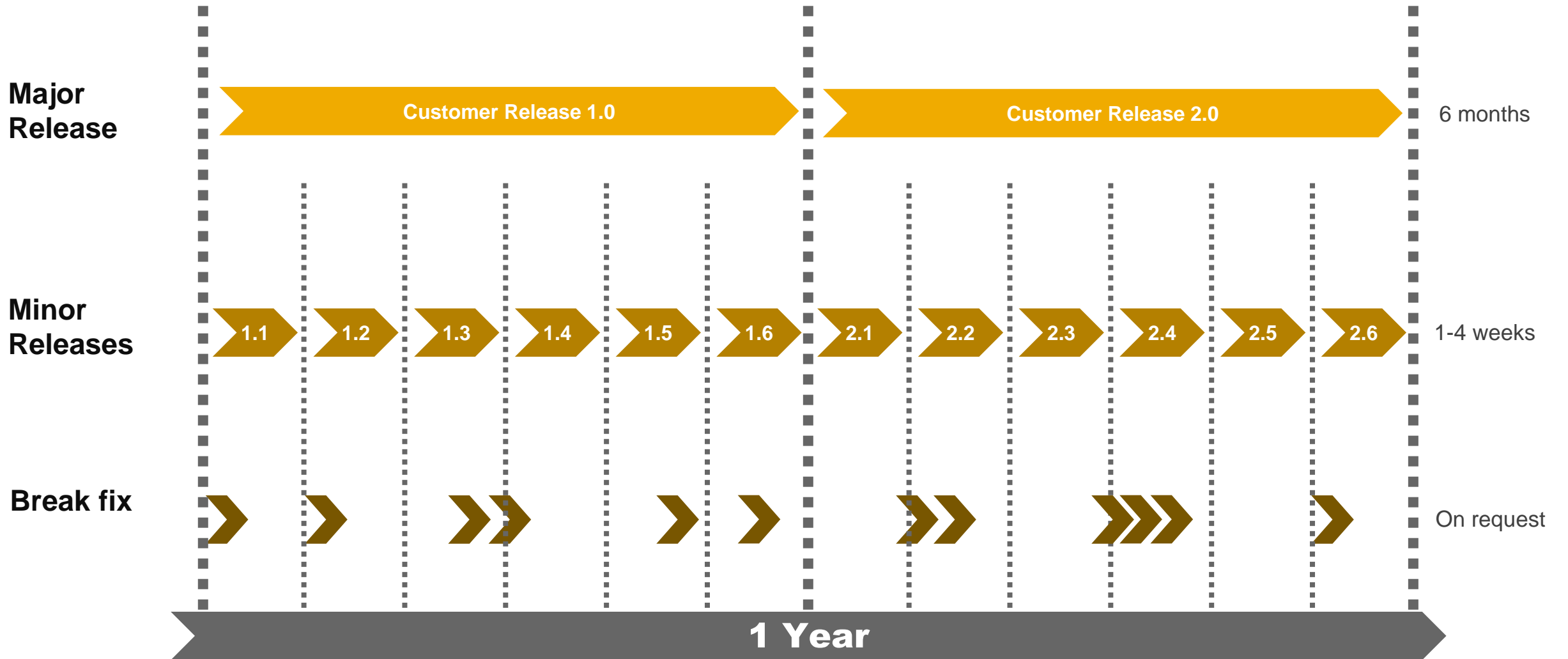

This is the current state of planning and may be changed by SAP at any time.



# Demo

Business & IT requirement

# Role: Process Expert

# Role: Business Manager

SAP Labs Preview

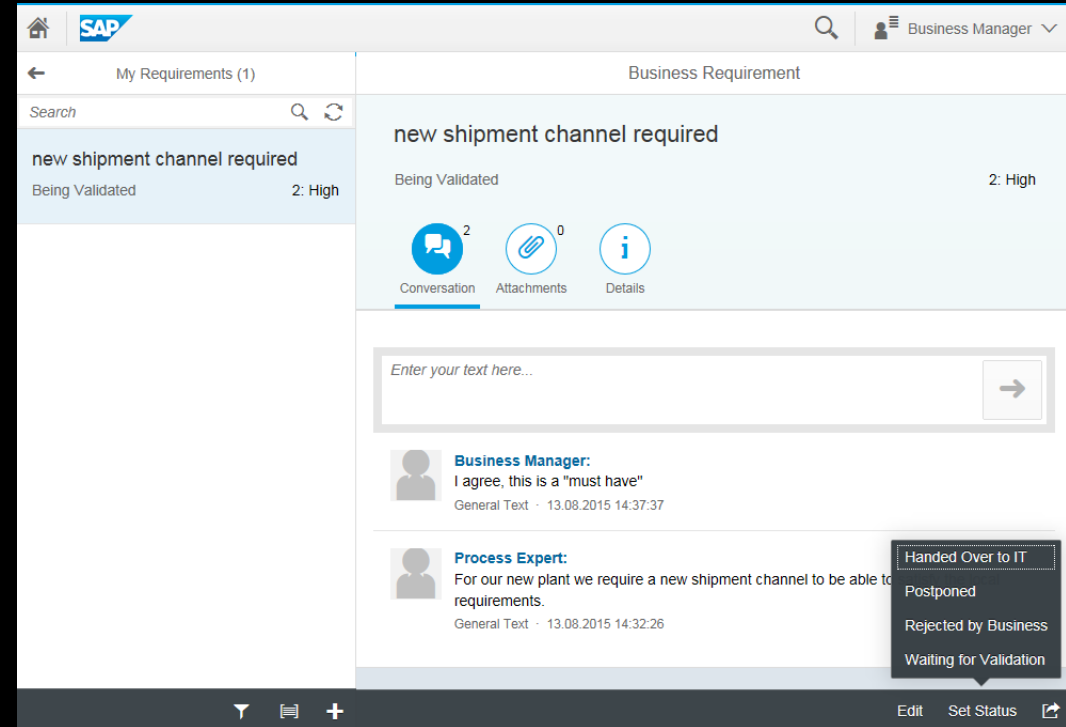
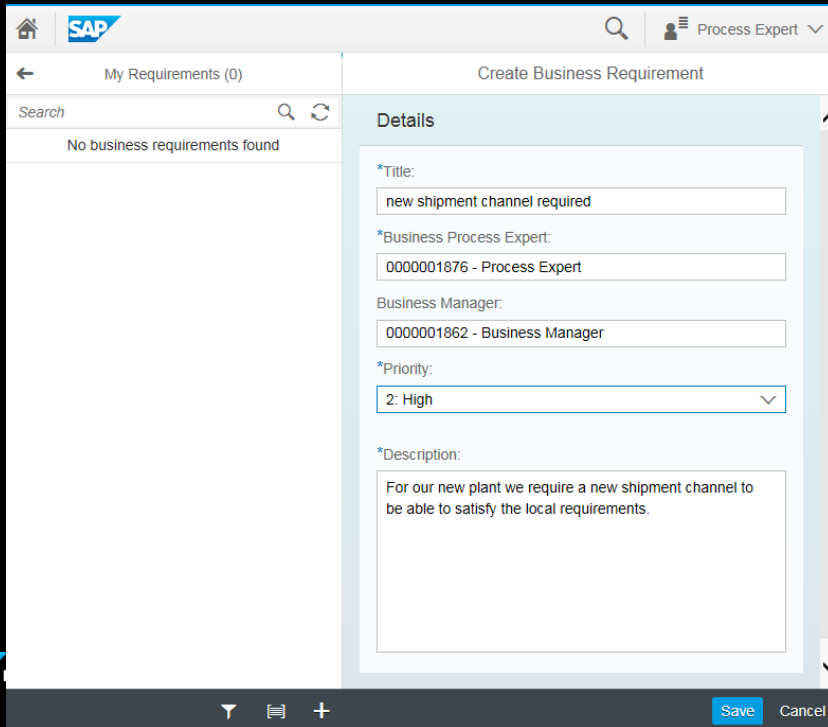
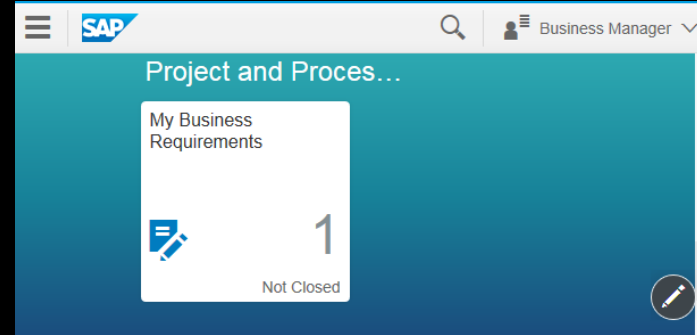
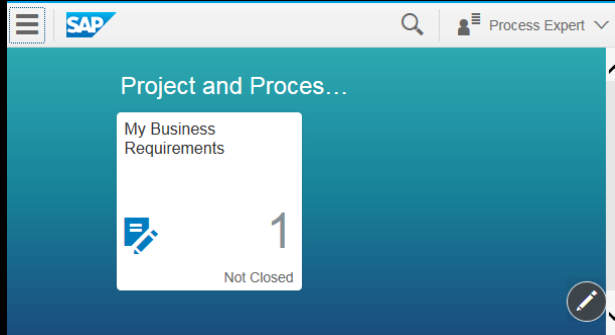

# Role: IT Architect

SAP Labs Preview

**SAP Solution Manager IT Service Management** Share Personalize System News Log Off

IT Requirement: 800002745, new shipment channel required Go Advanced

Save Display Cancel Edit Create Follow-Up Attach Overview PDF Actions Auto Complete More

**Status Overview**

1 Created 2 Validating Requirement 3 IT Scope Finalized 4 Business Information Missing 5 IT Scope Postponed 6 IT Scope Committed 7 Requirement Rejected

**Details** Edit

**General Data**

ID: 800002745  
\* Description: new shipment channel required  
Sold-To Party: Business Manager  
\* Solution Architect: IT Architect  
\* Requirement Manager: Change Manager  
Business Process Expert: Process Expert

**Implementation Data**

Change Cycle / Phase: Maintenance Q1 (ERP, CRM, EWM) Created  
Type / ID: Phase Cycle 8000002521 8000002521  
Landscape / Branch: Solution Maintenance  
Development Close:  
Go-Live Date:

**Change Planning**

Risk: Medium

**Project Planning**

Project Management Project:  
Project Management Task:  
Start Date:  
Finish Date:  
Task Duration:  
Estimated Work:  
Total Work: 0.00

**Category**

Level 1: Business Applications  
Level 2: SAP  
Level 3: Sales & Distribution  
Level 4:

**Processing Data**

Status: Created  
Impact/Urgency: High  
Recomm.Prio/Prio: 2: High

**Dates**

Created On:	13.08.2015	14:39
Changed On:	13.08.2015	14:39
Requested Start:	13.08.2015	14:39:22
Requested End:	16.08.2015	14:39:22
Due By:	27.08.2015	14:39:22

**Text** Add Text Insert Text Template Maintain Text Templates

**Requirements Description** Language: English



Public

# Role: IT Architect

SAP Labs Preview

**SAP Solution Manager IT Service Management** Share Personalize System News Log Off

IT Requirement: 800002745, new shipment channel required Saved Searches [ ] Go Advanced [ ]

Save Display Cancel Edit Create Follow-Up Attach Overview PDF Actions Auto Complete More

**Details** Please specify a checklist and complete all of the items on it 12 Messages

- Item 800000010: Enter a partner ID for checklist step
- Item 800000020: Enter a partner ID for checklist step

Level 2: SAP  
Level 3: Sales & Distribution  
Level 4: [ ]

**Areas to be Investigated** Edit List

Checklist Selection: Validate Requirement

Add Display Process Flow Display All Steps Display Active Steps Display Inactive Steps

Action	Step	Partner Function	Partner	Option	Step Status	Posting Date
<a></a>	Hardware / Infrastructure	<a></a> Employee Responsible		<a></a>	Open	
<a></a>	Licenses	<a></a> Employee Responsible		<a></a>	Open	
<a></a>	UI / Usability / End User Impact	<a></a> Employee Responsible		<a></a>	Open	
<a></a>	DB Change / Conversion Impact	<a></a> Employee Responsible		<a></a>	Open	
<a></a>	Interface Change	<a></a> Employee Responsible		<a></a>	Open	
<a></a>	Software Package Upgrade	<a></a> Employee Responsible		<a></a>	Open	
<a></a>	Backend Procedures	<a></a> Employee Responsible		<a></a>	Open	
<a></a>	Interfaces to other applications	<a></a> Employee Responsible		<a></a>	Open	
<a></a>	Configuration changes	<a></a> Employee Responsible		<a></a>	Open	
<a></a>	Testing	<a></a> Employee Responsible		<a></a>	Open	

Expand Back 1 2 Forward

**Text**

**Change Document** Edit

Actions	Transaction Type Title	Transaction ID	Description	Status	Configuration Item	Configuration Item Description
No result found						

**Attachments**

**Solution Documentation**



Public

# Process Management

# Process Management

**Process management in SAP Solution Manager 7.2 delivers dramatically improved solution documentation capabilities.**

## SAP Solution Manager solution documentation

- Web-based documentation experience
- Integrated BPMN process editor
- Multi-level hierarchies
- Processes assembled from re-use libraries

## Integrated process experience

- Project and Portfolio Management integration
- Business Process Monitoring integration
- Change and Request Management integration
- Test Management integration

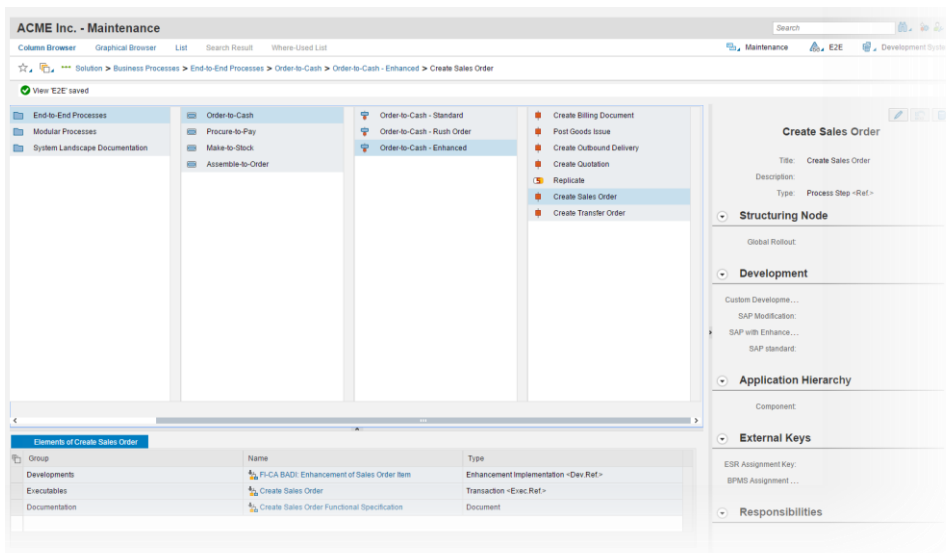

# SAP Solution Manager 7.2

Yes, processes have more than three levels!



**Bridging the gap between IT and business!**

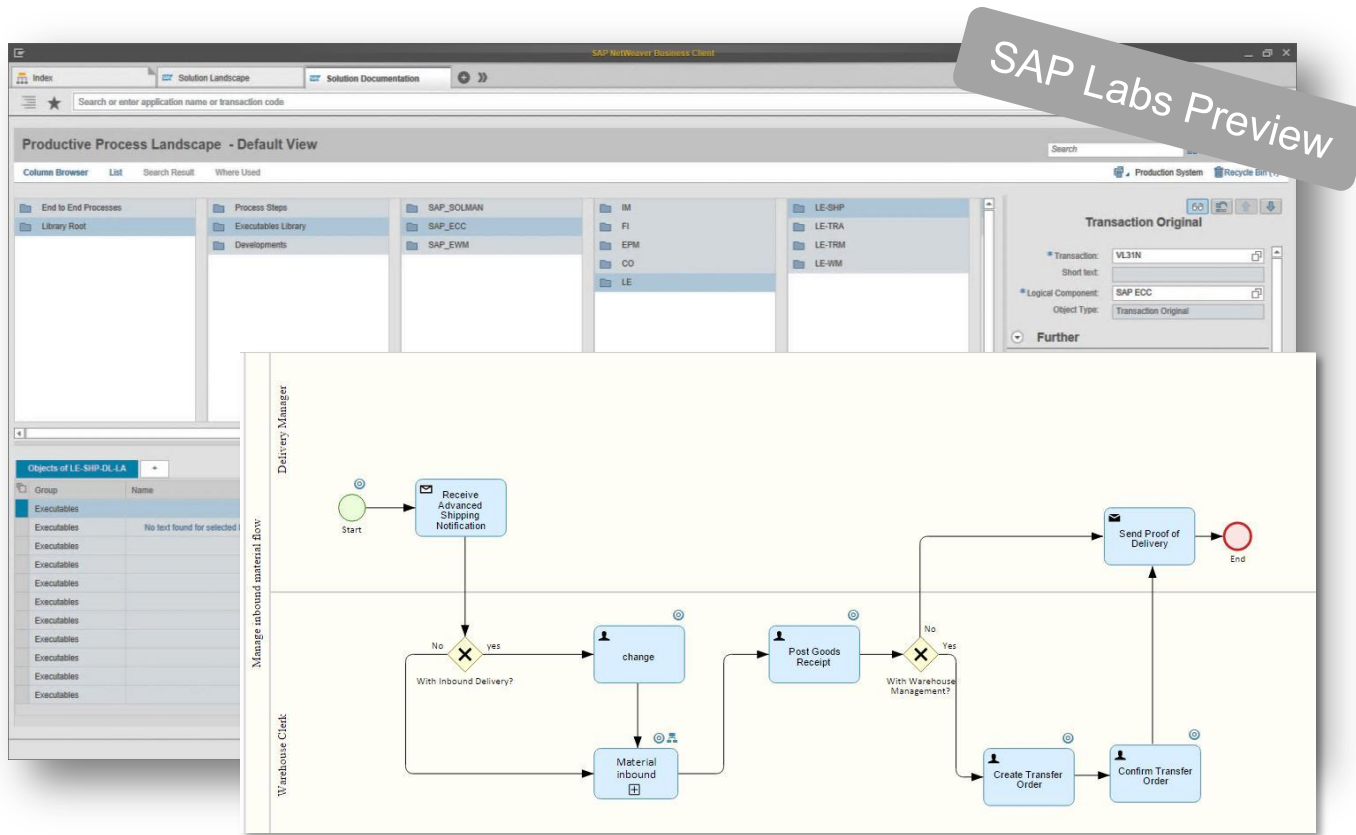

## Seamless integration of business and IT views

- No data outside SAP Solution Manager
- Role-specific views
- Continuous refinement of process models

## More than 3 business process levels

- SAP Solution Manager 7.2 delivers an environment which adapts itself to customer modelling standards and gets rid off the artificial three-tier limitation.

## Openness for other modeling tool vendors

- SAP Solution Manager 7.2 allows customers to plug their preferred modeling tools into SAP Solution Manager via an open bi-directional interface that must be supported by the vendor

This is the current state of planning and may be changed by SAP at any time.

# New Solution Documentation in 7.2

SAP Labs Preview

## Intuitive Process Visualization

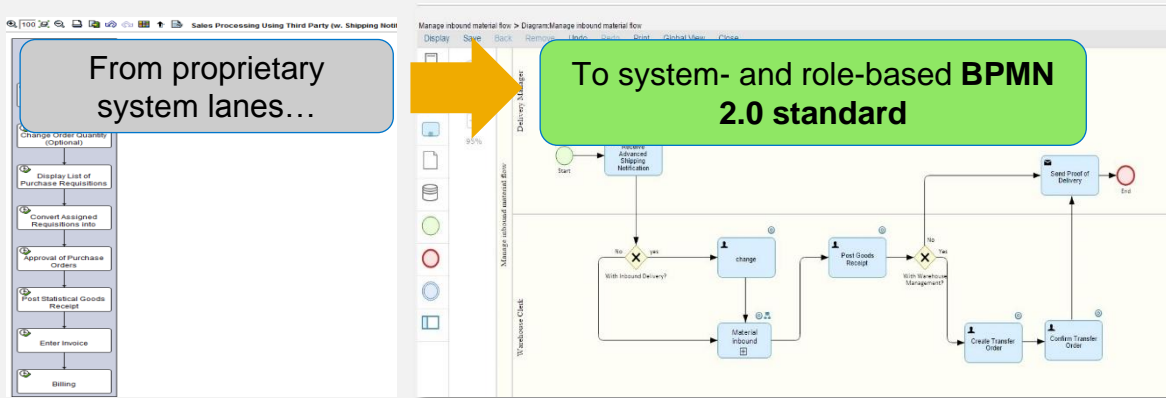

## Simplified Landscape Management

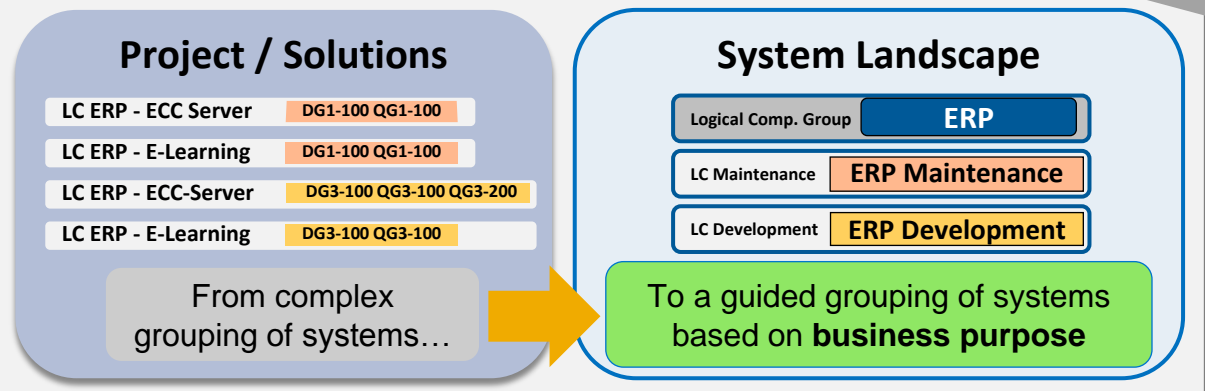

## Flexible Process Management

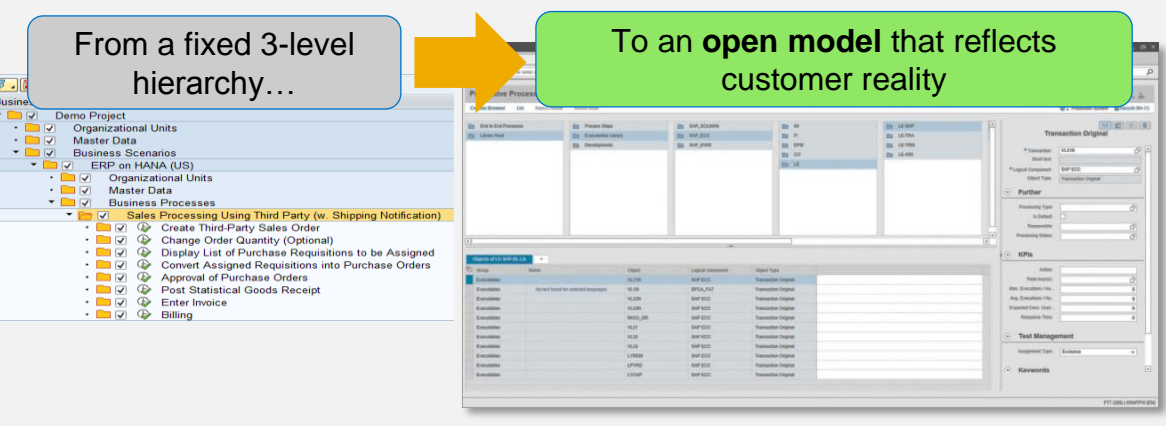

## Easy Process re-documentation

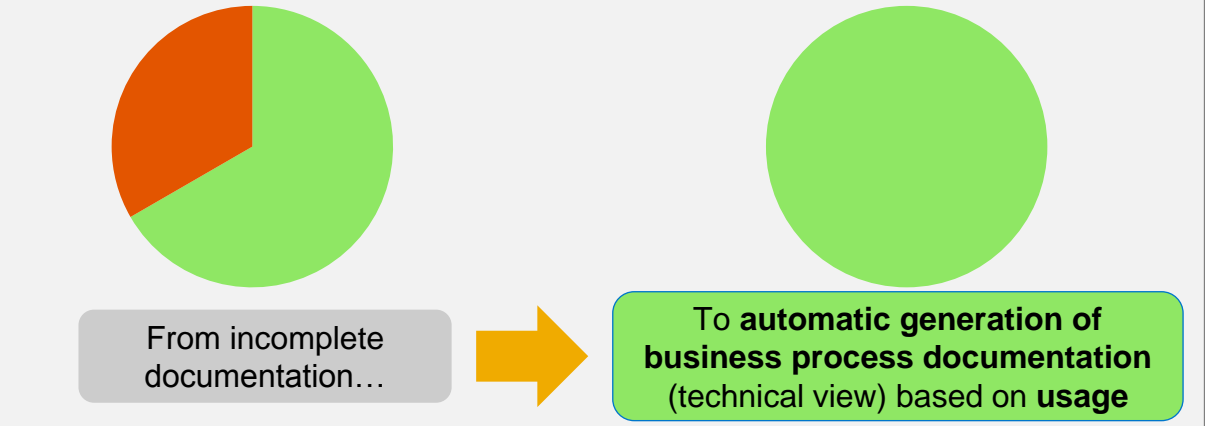

This is the current state of planning and may be changed by SAP at any time.



# New and simplified business user experience

Graphical process modeling directly in SAP Solution Manager

SAP Labs Preview

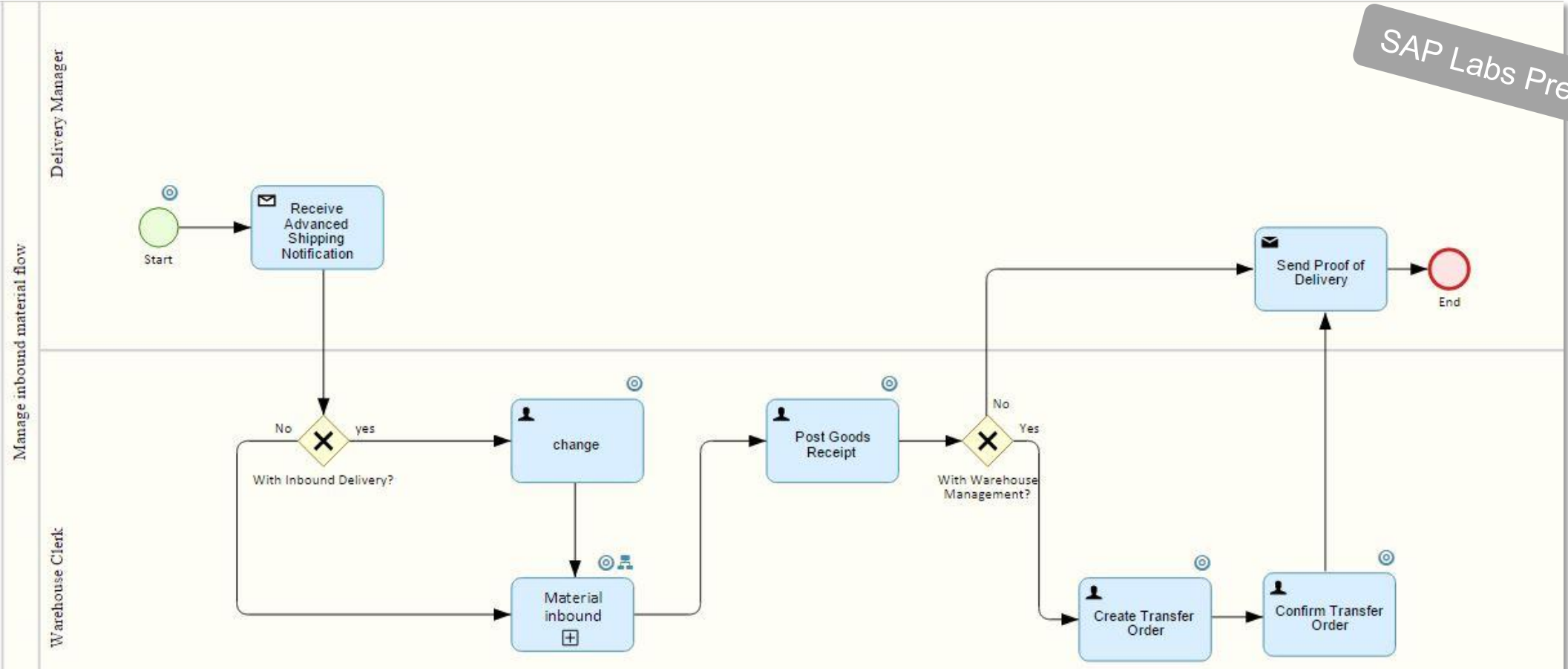

 **Processes are easy to consume!**

This is the current state of planning and may be changed by SAP at any time.

# Change the game with SAP Solution Manager 7.2

## Process design in SAP Solution Manager 7.2 with libraries

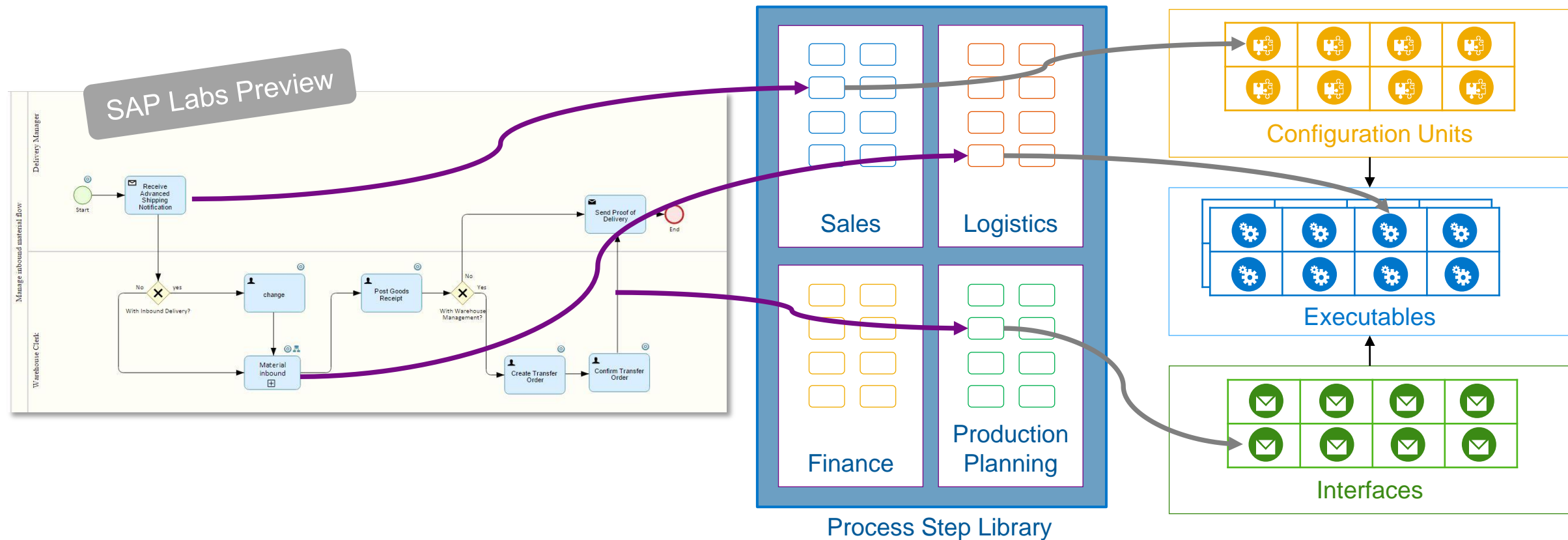

This is the current state of planning and may be changed by SAP at any time.

# SAP Solution Manager 7.2

SAP Labs Preview

## Solution

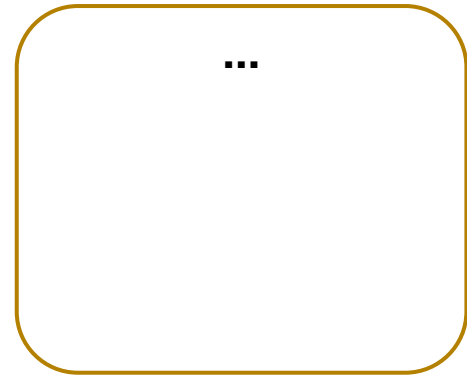
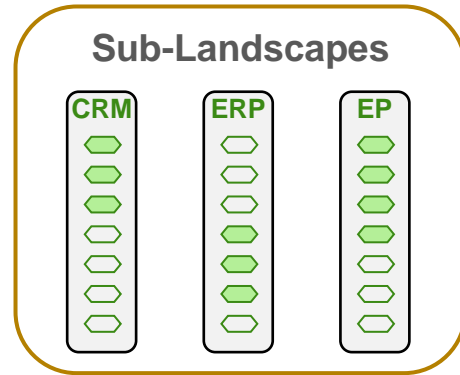
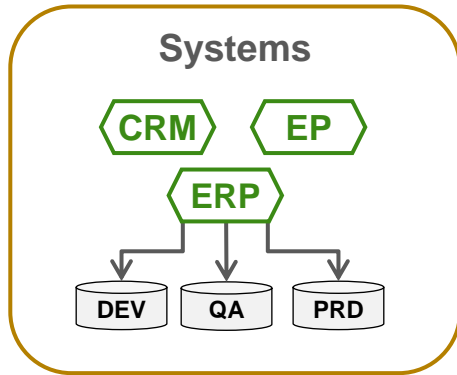
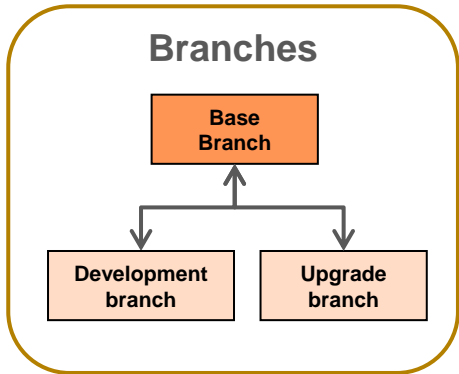
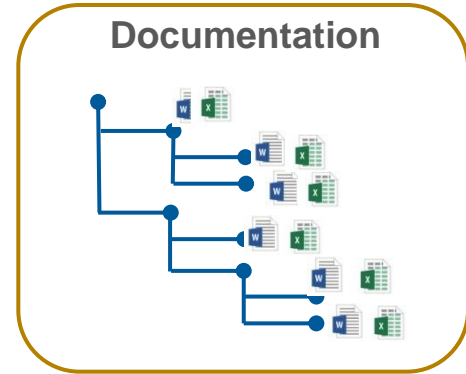
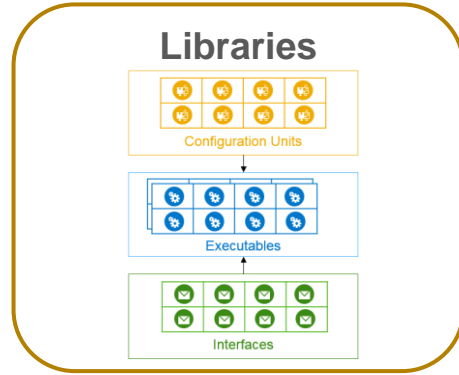
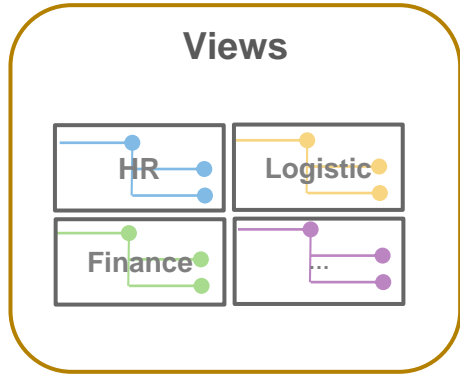
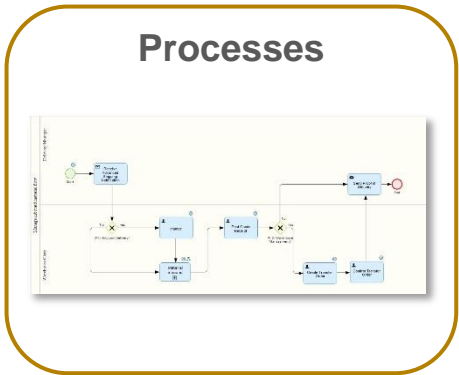

This is the current state of planning and may be changed by SAP at any time.

# SAP Solution Manager 7.2

Process lifecycle is based on *branches*

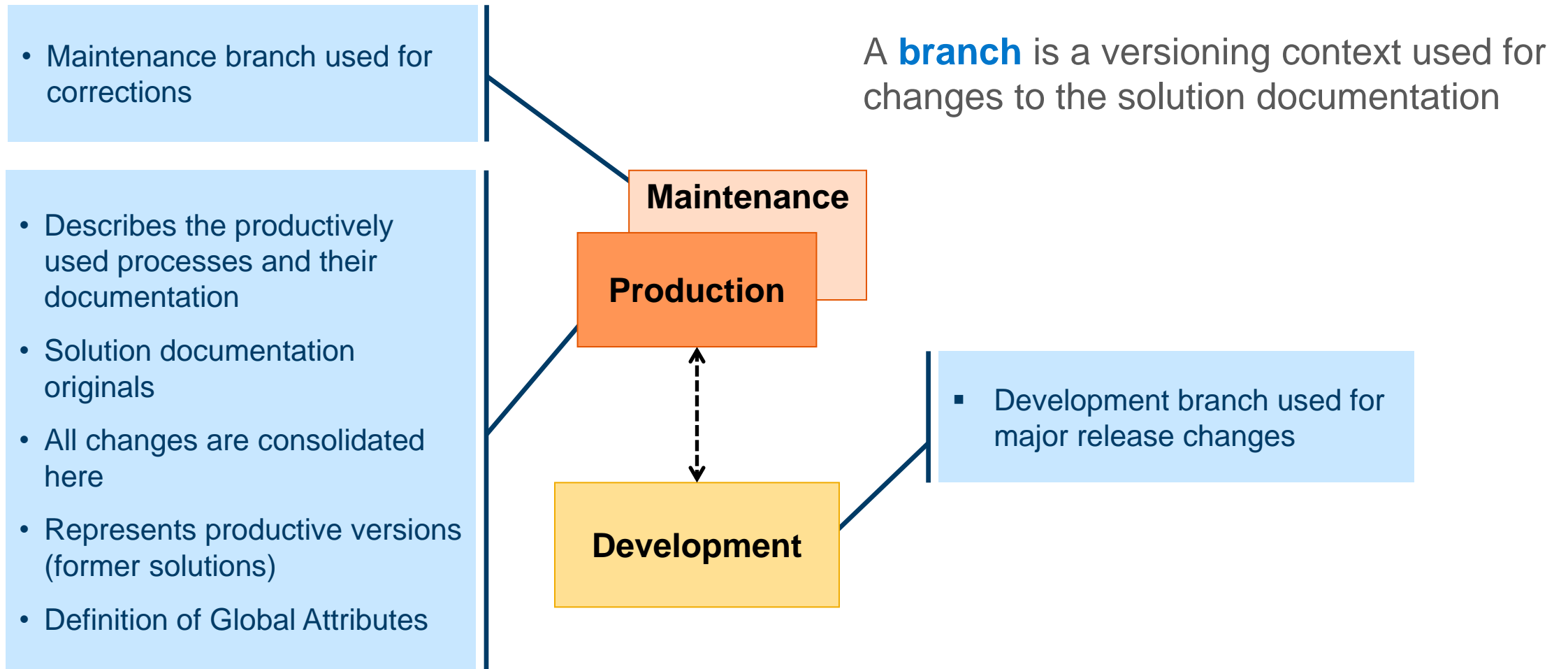

This is the current state of planning and may be changed by SAP at any time.

# Summary

**Process management** delivered with  
SAP Solution Manager 7.2

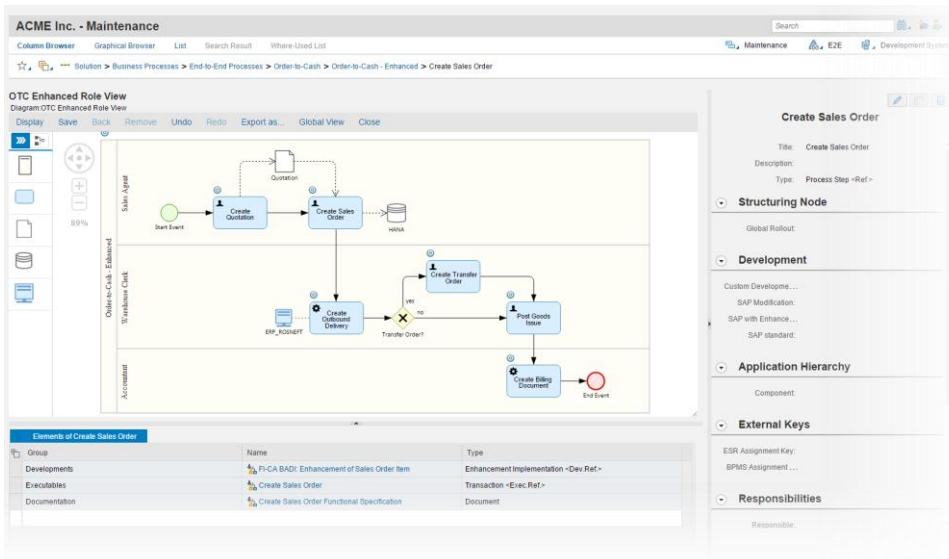

SAP Solution Manager solution documentation

- Web-based documentation experience ✓
- Integrated BPMN process editor ✓
- Multi-level hierarchies ✓
- Processes assembled from re-use libraries ✓

This is the current state of planning and may be changed by SAP at any time.

# Demo

New graphical modeling

Process diagram “by Role” designed to explain process flow.

Role

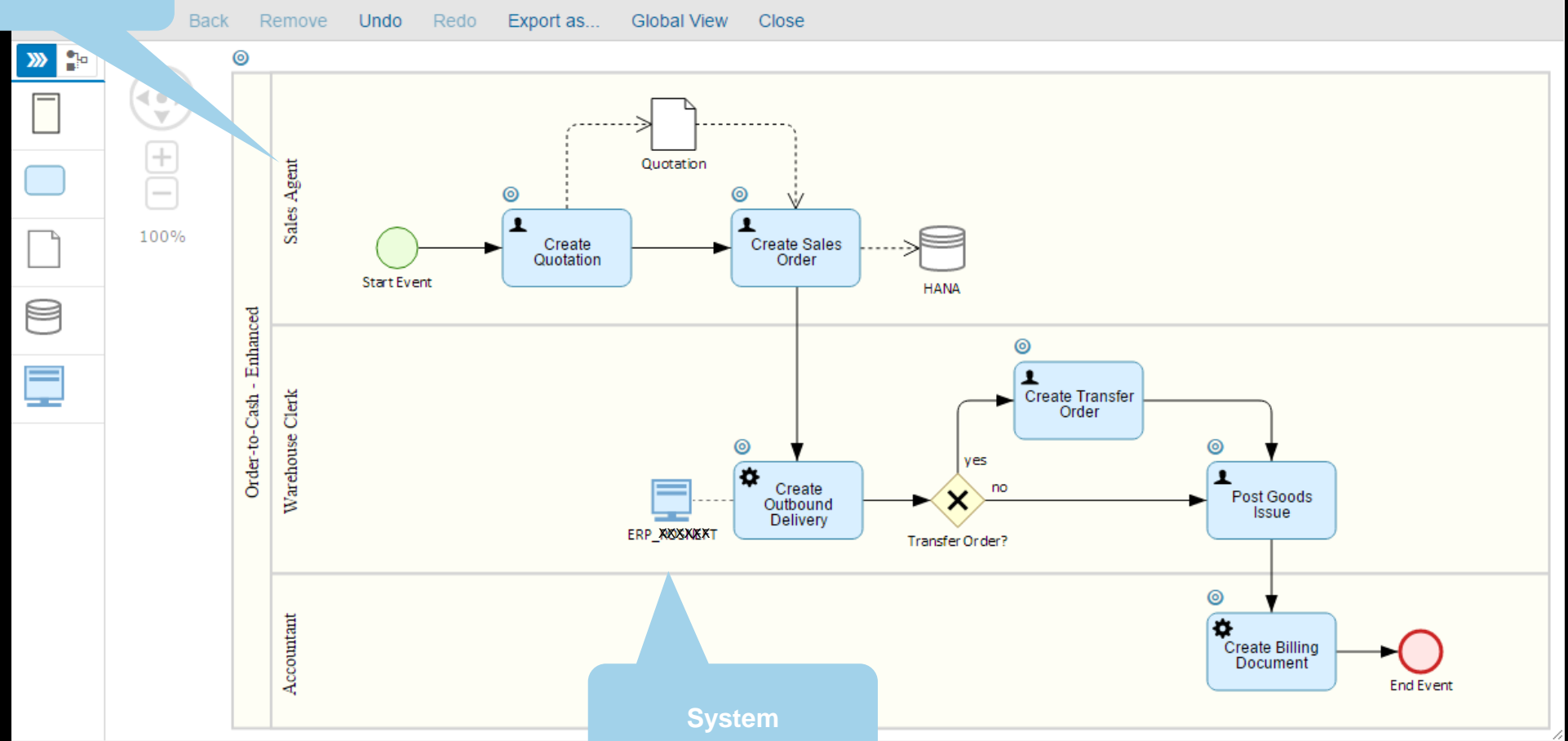

System

Process diagram “by System” designed for Business Process Monitoring.

System

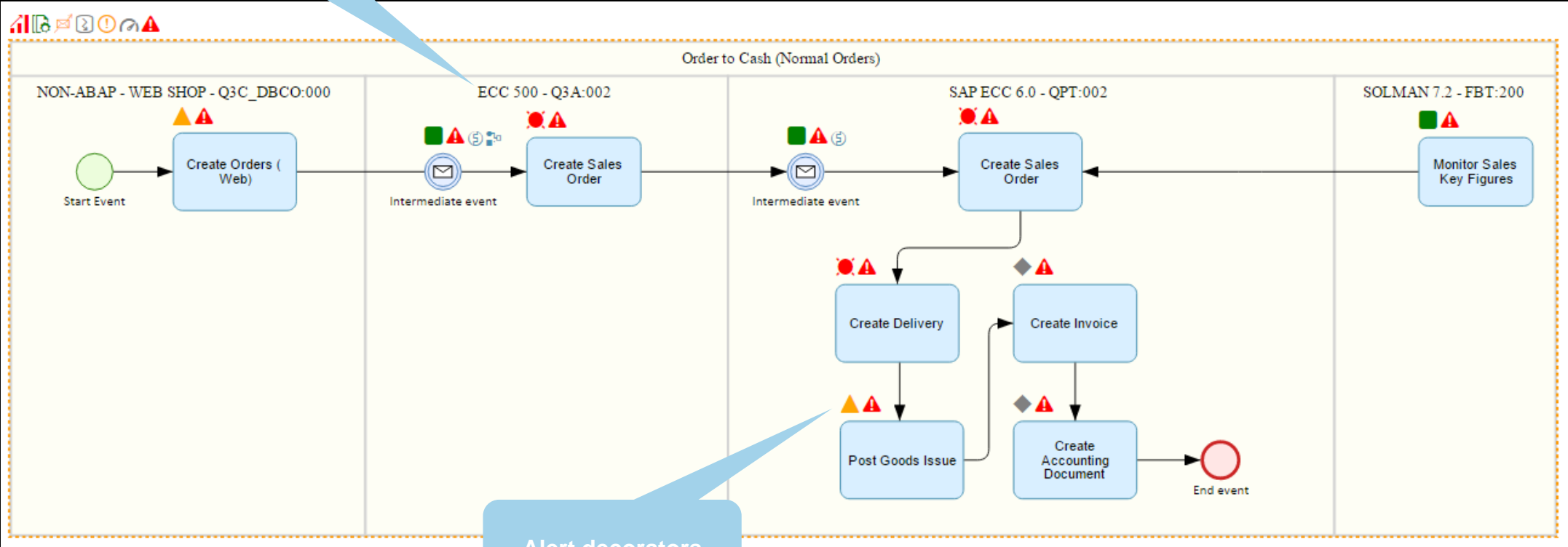

Alert decorators



# Outlook

How to prepare, what to do today?

# SAP Solution Manager 7.2 – Start your journey to 7.2 today



SAP recommends that you start preparing TODAY even if you plan to adopt SAP Solution Manager 7.2 well after end of ramp-up.

SAP has developed upgrade support like best practices, services and analysis tools which are available/planned for SAP Solution Manager 7.1

Do not hesitate to invest in solution documentation today. Follow our guidelines and you can start benefitting now without increasing your upgrade efforts!

**Now is the time to start the activation process for your solution documentation!**

# Start using SAP Solution Manager innovation today on 7.1

## IT Project & Portfolio Management

IT PPM replaces SAP Solution Manager 7.1 project management capabilities in SAP Solution Manager 7.2. The functional differences between IT PPM on SAP Solution Manager 7.1 and on SAP Solution Manager 7.2 are non-disruptive and therefore manageable. Using IT PPM already on 7.1 simplifies the transition to 7.2.

## Automated Blueprint Generation

In SAP Solution Manager 7.2, the libraries are organized structured by the application component hierarchy. The blueprint generation report available on SAP Solution Manager 7.1 builds up a process step library structured similarly and using customer system usage. You can download the report from [SAP note 2061626](#), and you can find more information in [this document](#).

## Preparing Business Process Monitoring

In SAP Solution Manager 7.2, all Business Process Monitoring capabilities will be available on the Monitoring and Alerting Infrastructure ONLY. Customers who are using capabilities like Business Process Monitoring on SAP Solution Manager 7.1 SP12 (or higher) and who have not yet completed the transition to MAI should move to MAI before the upgrade to SAP Solution Manager 7.2

## Maintenance Planner

Maintenance Planner replaces Maintenance Optimizer in SAP Solution Manager 7.2 and is available optionally for SAP Solution Manager 7.1. Using the Maintenance Planner already on 7.1 simplifies the transition to 7.2. You can find more information in this [blog](#) and this [document](#).

# The upgrade road to success

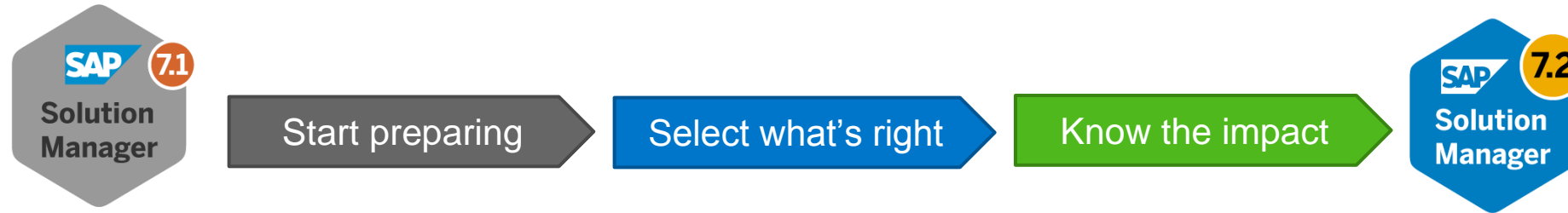

## For SAP Solution Manager customers we plan to offer

- quick identification of those parts of your solution documentation which matter to you
- decision support to plan and execute content activation
- best practices, services, and tools for the upgrade to SAP Solution Manager 7.2

**Your journey starts today!**

# SAP offers 3 accelerators for content activation

## SAP facilitates easy content activation with:

Best Practices for Solution Documentation: This document explains how to document your solution on SAP Solution Manager 7.1 in order to avoid post-activation efforts on SAP Solution Manager 7.2

Content Selection Tool: This tool provides comprehensive reporting about solution documentation today and allows customers to complete their selection for activation before the upgrade. The tool is available on SAP Solution Manager 7.1

Cloud Test Drive: An SAP Solution Manager 7.2 cloud appliance is planned to be available at Ramp-Up start. Customers can use it to test drive the activation process

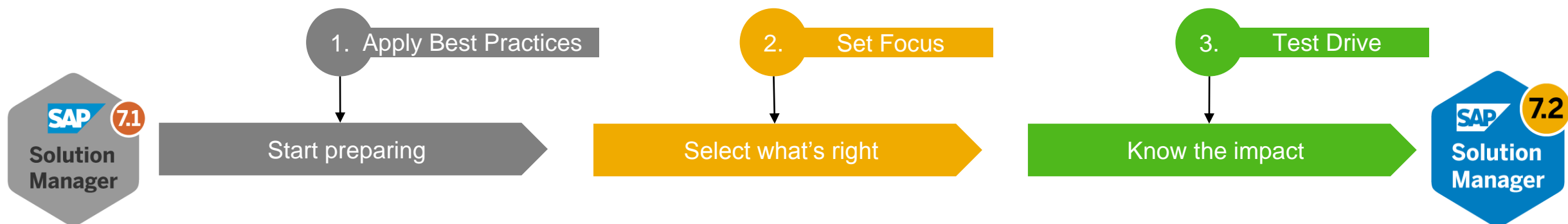

**With the 3 accelerators, customers are best prepared for the transition to 7.2**

# What happens when you upgrade to SAP Solution Manager 7.2?

## Upgrade to new functionality

### New:

- Solution Documentation
- Business and IT Requirement

### Improved:

- IT Service Management
- Change Control Management
- Business Process Analytics

## Upgrade User Experience

### Fiori meets SAP Solution Manager:

- SAP Solution Manager launchpad for personalized user experience
- Fiori Apps for dedicated use cases

## Upgrade to latest technology

### Also run on SAP HANA as a database:

- License for SAP Solution Manager included in support contract
- Migrate SAP HANA to consolidate all applications on HANA
- Build up experience in running HANA

### Stack Split

- SAP Solution Manager 7.2 runs 2 single stacks
- Split is done as part of upgrade procedure

## Upgrade to new maintenance interval

### Receive mainstream maintenance beyond 2017:

- Packaged corrections (notes, support packages)
- Technology updates (new databases and operating systems)

# Important to know & your next steps

## Upgrade details

**The upgrade from SAP Solution Manager 7.1 to 7.2 is *standard***

### Relevant for all customers:

- No CRM issues this time: SAP Solution Manager 7.2 does not contain a new SAP CRM release. As we only move to a new enhancement package, the impact of the 7.2 upgrade is significantly lower than in the 7.1 upgrade
- If you already adopted the Monitoring & Alerting infrastructure, then you are fine. **Note that business process monitoring based on the Monitoring and Alerting Infrastructure (MAI) is *mandatory* in 7.2**
- The split of ABAP and JAVA stacks, and the upgrade to SAP NetWeaver 7.40 are performed automatically in a standard upgrade procedure
- Activation of Solution Documentation can be prepared well in advance of the upgrade

### Optional upgrade step:

- The migration to SAP HANA fully supports the one-step-upgrade approach (i.e. the SAP standard for migrating to SAP HANA)

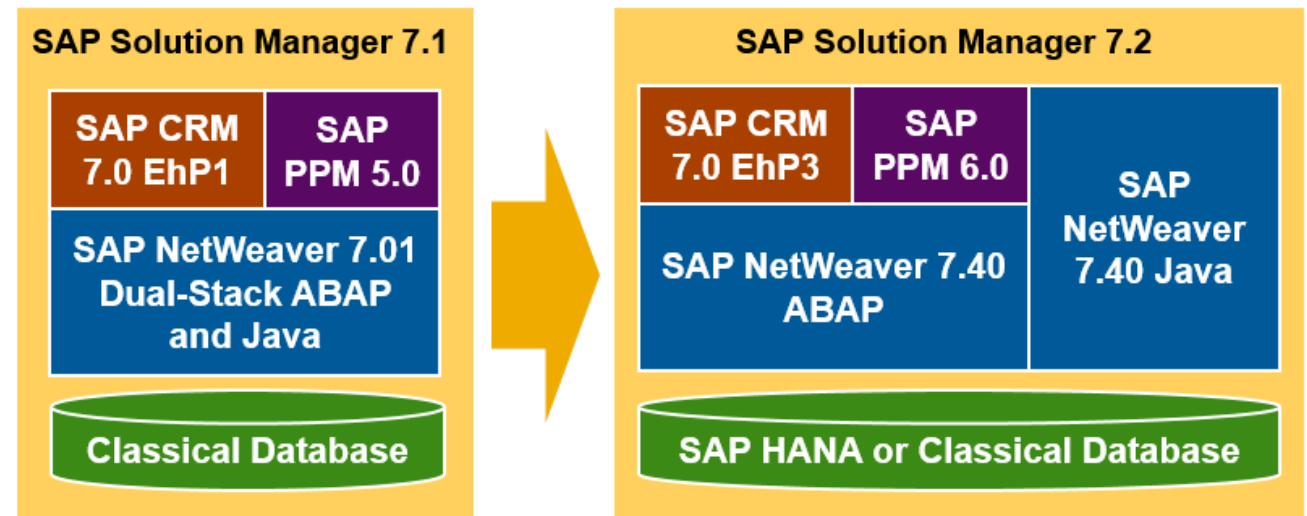

This is the current state of planning and may be changed by SAP at any time.

# SAP TechEd Online

Continue your SAP TechEd education after the event!

- Access replays of keynotes, Demo Jam, SAP TechEd live interviews, select lecture sessions, and more!
- Hands-on replays

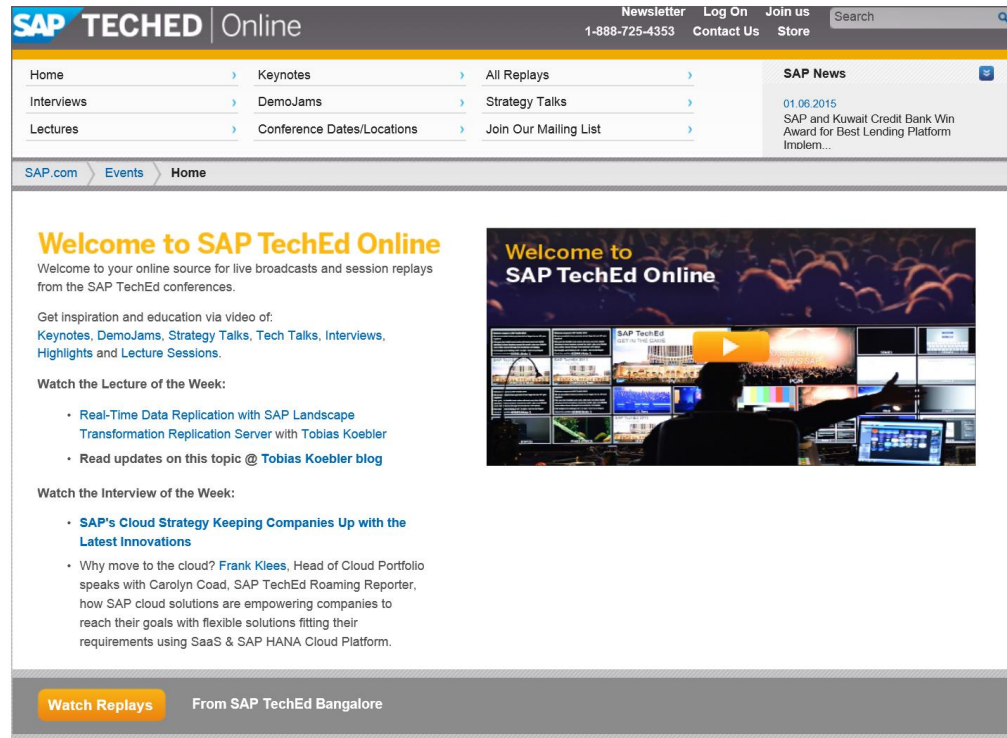

The screenshot shows the SAP TechEd Online website. The header includes the SAP logo, 'TECHED Online', and navigation links for Newsletter, Log On, Join us, Contact Us, and Store. A search bar is also present. The main navigation menu lists Home, Keynotes, All Replays, SAP News, Interviews, DemoJams, Strategy Talks, Lectures, and Conference Dates/Locations. The main content area features a 'Welcome to SAP TechEd Online' banner with a video player. Below the banner, there are sections for 'Watch the Lecture of the Week' and 'Watch the Interview of the Week', each with a list of featured content. A 'Watch Replays' button is located at the bottom left of the page.

<http://sapteched.com/online>



# Further Information

## Related SAP TechEd sessions:

ITM100 – Managing Hybrid Solutions (Lecture)

ITM105 – Test Management with SAP Solution Manager 7.2 – Overview (Lecture)

ITM202 – SAP Solution Manager Road Map: What's the Strategic Direction (Lecture)

ITM205 – IT Service Management in SAP Solution Manager – A Strategic Overview (Lecture)

ITM208 – Business Process Operations in SAP Solution Manager 7.2 (Lecture)

ITM214 – Application Operations Overview: News About SAP Solution Manager 7.2 (Lecture)

ITM219 - Be Prepared for ITSM and CHARM in SAP Solution Manager 7.2 (Lecture)

ITM220 – Making the New Graphical Modeling Work for You in SAP Solution Manager 7.2 (Lecture)

## SAP Public Web

<http://scn.sap.com/docs/DOC-47361>

<http://support.sap.com/solutionmanager>

## SAP Education and Certification Opportunities

<http://support.sap.com/esacademy>

## Watch SAP TechEd Online

[www.saptech.com/online](http://www.saptech.com/online)

# Feedback

Please complete your session evaluation for  
**ITM 218.**





# Thank you

Contact information:

F name MI. L name

Title

Address

Phone number

# © 2015 SAP SE or an SAP affiliate company. All rights reserved.

---

No part of this publication may be reproduced or transmitted in any form or for any purpose without the express permission of SAP SE or an SAP affiliate company.

SAP and other SAP products and services mentioned herein as well as their respective logos are trademarks or registered trademarks of SAP SE (or an SAP affiliate company) in Germany and other countries. Please see <http://global12.sap.com/corporate-en/legal/copyright/index.epx> for additional trademark information and notices.

Some software products marketed by SAP SE and its distributors contain proprietary software components of other software vendors.

National product specifications may vary.

These materials are provided by SAP SE or an SAP affiliate company for informational purposes only, without representation or warranty of any kind, and SAP SE or its affiliated companies shall not be liable for errors or omissions with respect to the materials. The only warranties for SAP SE or SAP affiliate company products and services are those that are set forth in the express warranty statements accompanying such products and services, if any. Nothing herein should be construed as constituting an additional warranty.

In particular, SAP SE or its affiliated companies have no obligation to pursue any course of business outlined in this document or any related presentation, or to develop or release any functionality mentioned therein. This document, or any related presentation, and SAP SE's or its affiliated companies' strategy and possible future developments, products, and/or platform directions and functionality are all subject to change and may be changed by SAP SE or its affiliated companies at any time for any reason without notice. The information in this document is not a commitment, promise, or legal obligation to deliver any material, code, or functionality. All forward-looking statements are subject to various risks and uncertainties that could cause actual results to differ materially from expectations. Readers are cautioned not to place undue reliance on these forward-looking statements, which speak only as of their dates, and they should not be relied upon in making purchasing decisions.