

IVT vs. Profile Rail

A Technical Comparison Between Integral-V™ Technology (IVT) and Linear Re-circulating Ball Bearing and Guideway Assemblies (Profile Rail)

Kevin Bischel
Sr. System Design Engineer

Introduction

Historically, one of the more common linear guidance systems used has been bearing blocks containing re-circulating ball bearings running on profiled steel rails that are fastened to a structure. In recent years, PBC Linear has introduced another type of linear guidance system called Integral-V™ Technology (IVT). In these systems, cam rollers of v-profile run on steel raceways that are mechanically fixed into a structural aluminum component to form a unified rail component.

The purpose of this paper is to describe how the precisions of the two systems are achieved when they are manufactured and installed. Finally, a cost comparison for a theoretical application is given.

Overview of PRT

A linear guidance system of this type is shown in Fig. 1: at right. Such systems were introduced decades ago and there are many suppliers of such systems in the market today. Each supplier has proprietary designs for their re-circulating ball bearings and their profile rails. The profile steel rails are precision ground and the ball bearings of the bearing blocks run directly on the rail's raceway surfaces. Such ground rails provide high accuracy,

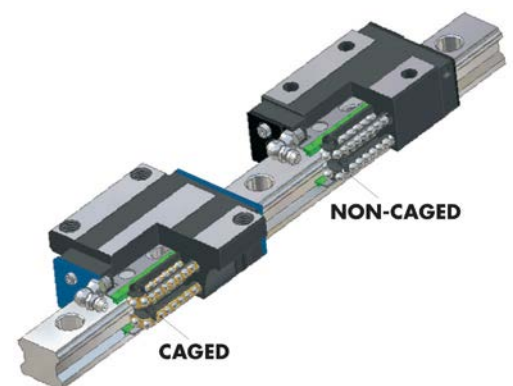

▲ Fig. 1: Cut-away views of re-circulating bearing blocks and a steel profile rail.

excellent precision, high load capacity, and high system rigidity. Systems are available with different grades of precision and bearing preload.

Grade Accuracy	Normal (N)	High (H)	Precision (P)	Super-Precision (S)	Ultra-Precision (U)
Tolerance of Height (H)	± 0.1	± 0.04	- 0.04	- 0.02	- 0.01
Tolerance of Width (W)	± 0.1	± 0.04	- 0.04	- 0.02	- 0.01
Difference in Heights (H)	0.03	0.02	0.01	0.005	0.003
Difference in Widths (W)	0.03	0.02	0.01	0.005	0.003
Running parallelism of BG block surface C with respect to surface A - Refer to ΔC					
Running parallelism of BG block surface D with respect to surface B - Refer to ΔD					

The amount of deflection between the bearing block and profile rail due to an applied load defines the system's rigidity. The bearing blocks can be supplied with different fits between the ball bearings and the rails ranging from clearance fits through various levels of preload. Using preloaded bearings increases the rigidity of the system. If a force is applied to the ball bearings without a preload, an elastic deformation proportional to the applied force to the 2/3 power will result.³

Equation 1

$$\delta \propto W^{2/5}$$

where: δ = elastic deformation
 W = applied force

The elastic deformation will be relatively large as loading begins. Then as the load increases, the relative increase in deformation for each increase in load will be less and less. By starting with a preload on the bearings, the relative increase in deformation when loading begins is less than for non-preloaded bearings and the relative deformation continues to be less as loading is increased.

Rail Length & Running Parallelism Accuracy Standard

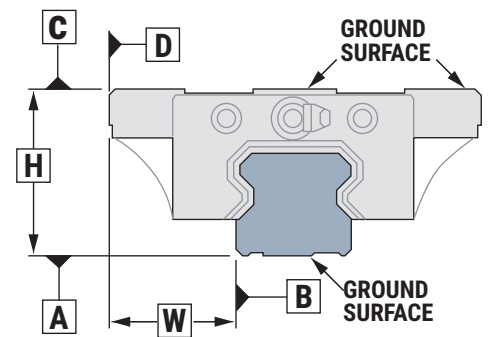
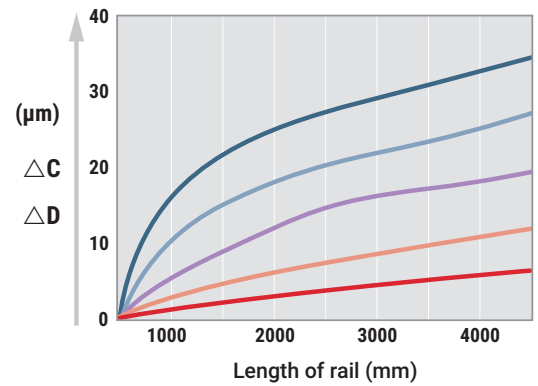

Fig. 2: Example of accuracy ratings.

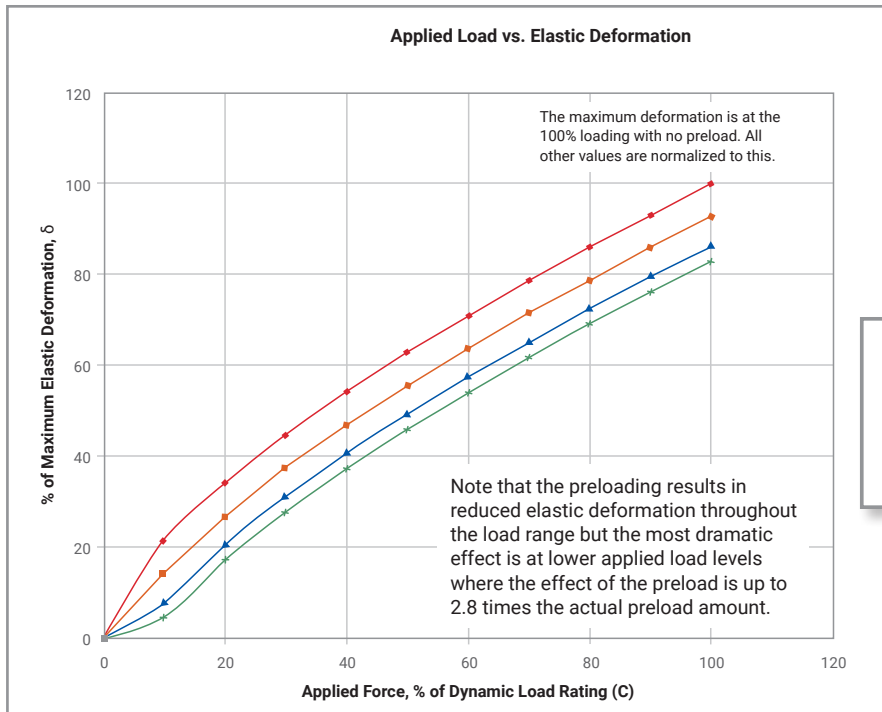
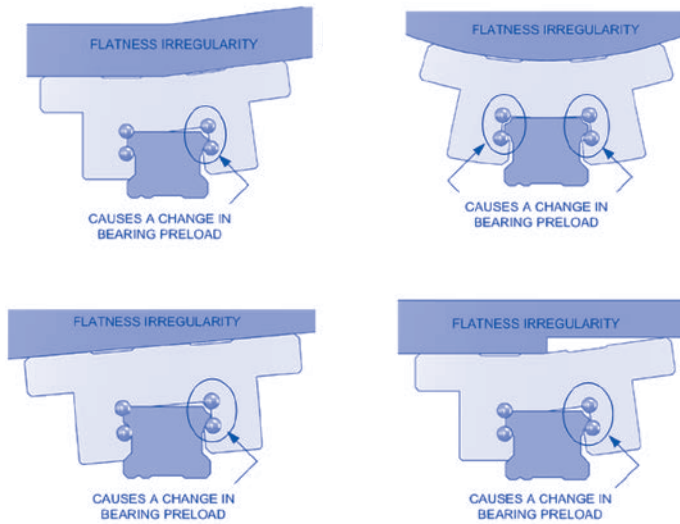

Fig. 3: Effect of bearing preload on the elastic deformation of the bearing/race system.

Preloading the bearings causes internal stress within the bearing block, resulting in some reduction in product life. However, if the part will be exposed to shock or vibration loading conditions, a preload will absorb load and will help lengthen the life of the part. Preloaded bearings are less tolerant of dimensional imperfections in the installation because the preload causes elastic deformation of the rolling elements. Extra care should be taken regarding the accuracy of mounting surfaces for preloaded bearings.

It is also important that the surface mounted to the bearing blocks be flat or else the bearing block can be deformed and the specified preload will not be achieved.



Grade	Preload Force
Clearance	0
No Preload	0
Light Preload	0.02 x C
Middle Preload	0.05 x C
Heavy Preload	0.07

Where "C" is the dynamic load rating.

▲ **Fig. 4:** Example of preloading levels used.

◀ **Fig. 5:** Surface flatness effecting the bearing block preload.

Fig. 6: General information regarding applications.

Type of Preload	Effect of Preload					Condition of Use	Applications
	Life	Stiffness (Rigidity)	Vibration Energy Absorption	Bearing Friction	Tolerance of Mounting Misalignment		
Clearance/ No Preload	●	●	●	●	●	1. Light corrosion 2. 2 parallel axes 3. Low accuracy 4. Low friction 5. Light load	1. Welding machine 2. Cutting machine 3. Feeder 4. ATC 5. X & Y axis 6. Packaging machine
Light Preload	●	●	●	●	●	1. Cantilevered 2. Mono axis 3. Light load 4. High accuracy	1. NC lathe 2. EDN 3. Precision XY table 4. Robotic manipulator 5. Z-axis 6. PCB drilling
Medium Preload	●	●	●	●	●	1. Med. corrosion 2. Vibration	1. Machine center 2. NC lathe 3. Milling machine 4. Grinding wheel feed shaft
High Preload	●	●	●	●	●	1. High corrosion 2. Severe vibration 3. Heavy cutting	
	Decreases	Increases	Increases	Increases	Decreases		

Preloading requires that the bearing blocks and profile rail be matched and shipped as a unit. Clearance or standard fit bearing blocks and profile rails from a given supplier are generally interchangeable. Because each supplier has its own proprietary bearing design and geometry, the rails and bearing blocks of different suppliers are not interchangeable.

For corrosion resistance, stainless steel rails are available or steel rails with plating such as chrome, black oxide or electro-less nickel. Raydent surface treatment can also be specified for applications where corrosion resistance is required or periodic lubrication is difficult.

If the bearing block and profile rail system is not properly mounted, some of the inherent system accuracy and precision can be lost. Suppliers provide detailed installation instructions for such systems which should be referenced. Some items that must be planned to preserve the accuracy and precision of this type of system are as follows:

- It is critical that the rails be accurately aligned and that the mounting surfaces are flat and straight. This can require grinding of the mounting surfaces in some cases. Reference edges for alignment are necessary. Alignment surfaces on the rails are provided to match up against reference edges.
- When two or more rails are to be installed in parallel, it is critical that they are accurately located to prevent binding. Commonly, the bearing blocks on one rail will have a clearance fit to help compensate for any misalignment.

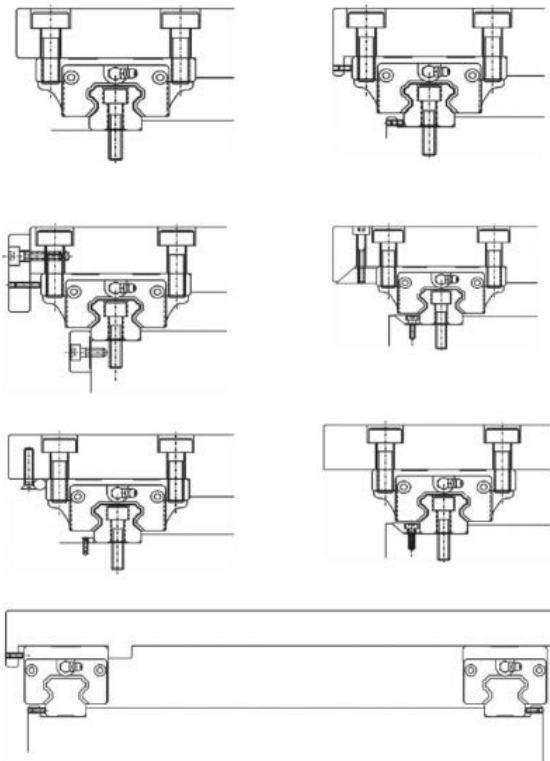

▲ Fig. 10: Common methods to attach bearing blocks and rails.

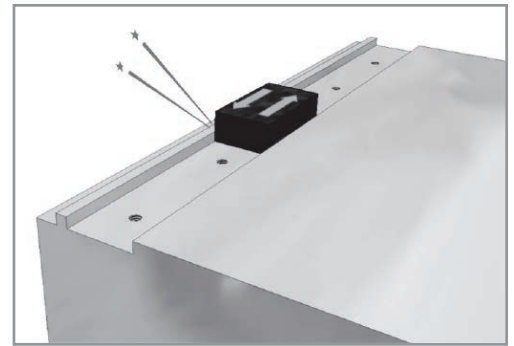

▲ Fig. 7: Remove dents, burrs, and dirt from the mounting surface.

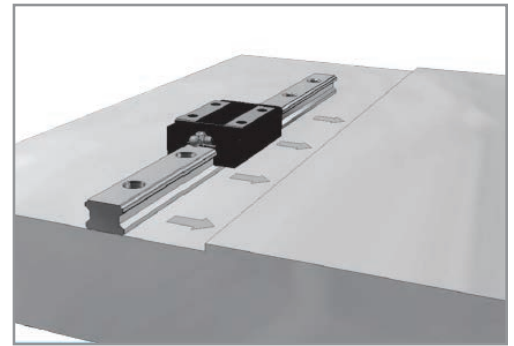

▲ Fig. 8: Align to a machined alignment edge.

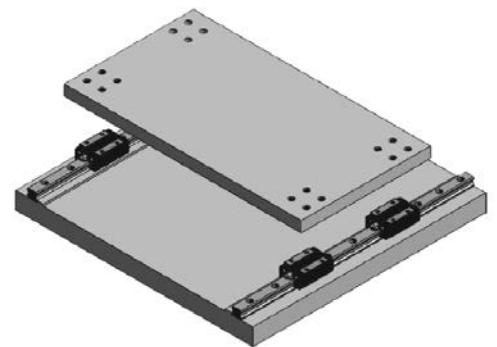

▲ Fig. 9: Two rails in parallel. Each has a machined alignment edge to rest against.

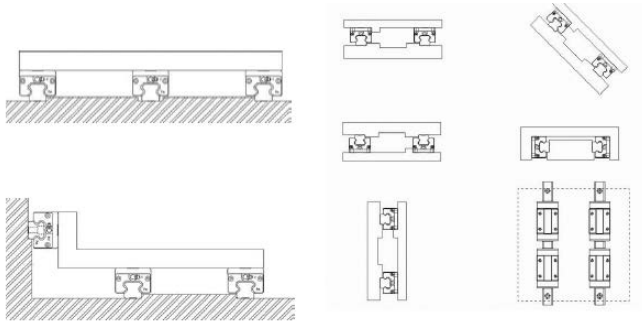

◀ **Fig. 11:** Some common mounting arrangements.

- The profile rails are fastened in place using multiple fasteners at intervals along the rail length. It is important that the fasteners be tightened starting with the center fastener and continuing towards both ends to obtain optimum accuracy.
- Dust and debris will adversely affect the motion characteristics and can also cause abnormally fast wear. Optional seals are available to help prevent the ingress of contaminants; but because the ball bearings run directly on the exposed rail raceways, it is recommended that bellows or other protective covers be used in very hostile environments.
- The rails of such systems are precision ground components that should be handled with care to preserve the accuracy and performance expected. Mishandling of a rail can cause a scar on a raceway that might impede the small diameter ball bearings as they pass. This will cause an area of rough motion in the stroke. The smaller the diameter of a rolling element, the more it is effected by a rail imperfection of a given size. The ball bearings of these systems are much smaller in diameter than the v-rollers of an IVT system.

Some advantages of such bearing block and profile rail systems are:

- The profile rails are precision ground providing smooth and accurate motion.
- They have high load capacity for a given envelope size.
- They are capable of high rigidity. The bearing blocks are available with fits that range from a slight clearance to varying levels of preload.
- Such systems are available from many different suppliers in a plethora of sizes and design variations. The envelope dimensions and the mounting hole patterns of many system sizes are the same from different suppliers.

Significant disadvantages are:

- The high cost of such systems compared to other systems.
- The high assembly and preparation cost necessary to preserve the accuracy and precision capability of this type of system.
- The rails are attached using multiple fasteners along the length of the rail which adds labor costs, assembly time, and the possibility of assembly error or fastener failure.
- To operate in dirty or wetted applications, the profile rail must often be covered with a bellows or other means.

Because each supplier has its own proprietary bearing design and geometry, the rails and bearing blocks of different suppliers are not interchangeable.

Integral-V™ Technology (IVT) Systems

This is a product recently introduced by PBC Linear in 2008. Cam rollers with a "v" profile run upon rails that are constructed of angled hardened steel raceways mechanically fixed into an anodized aluminum rail. Parallel raceways can be combined into one rail structure rather than being separate components that must be fastened in place with screws. PBC Linear's SIMO® (Simultaneous Integral Milling Operation) process provides precise rail surfaces that are accurately aligned to one another.

The rated precision of the IVT rails is as follows:

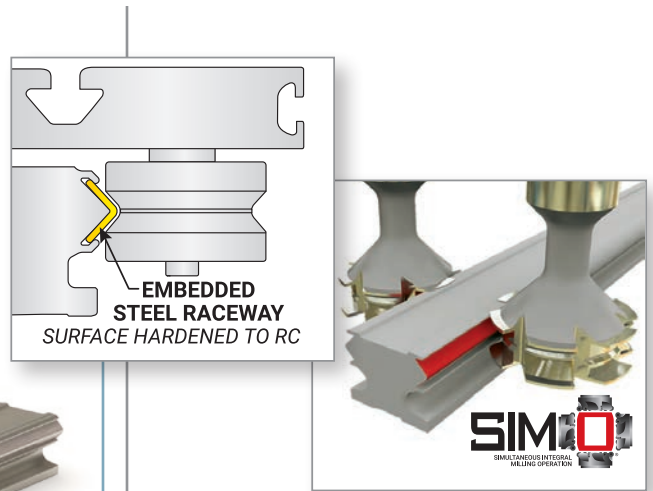

◀ **Fig. 12:** Example of an IVT Rail and Carriage System with schematic of IVT system

- Raceway to raceway $\pm 0.001"$
- Raceway to surface $\pm 0.002"$
- Straightness $\pm 0.002"/ft.$
- Flatness $.002"$
- Parallelism $\pm 0.001"$
- Twist $< 1/4"/ft.$

The design of the IVT rail system allows for the contact stresses created by the rollers on the outside surface of the steel v-race to be dispersed to much lower levels before they are transmitted to the supporting aluminum structure.

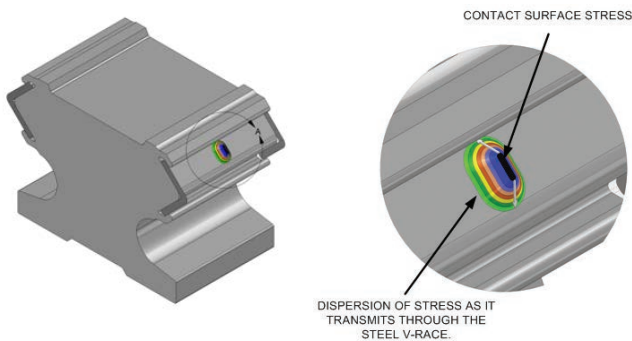

◀ **Fig. 13:** Steel v-race shown transparent so that the dispersion of the contact surface stress as it progresses through the steel v-race can be seen.

Steel profile rails are manufactured using a grinding process that produces excellent dimensional tolerances but at a relatively high cost.

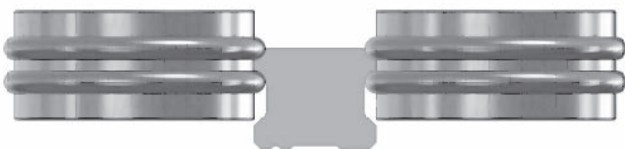

◀ **Fig. 14:** Simplified illustration of a steel profile rail being ground.

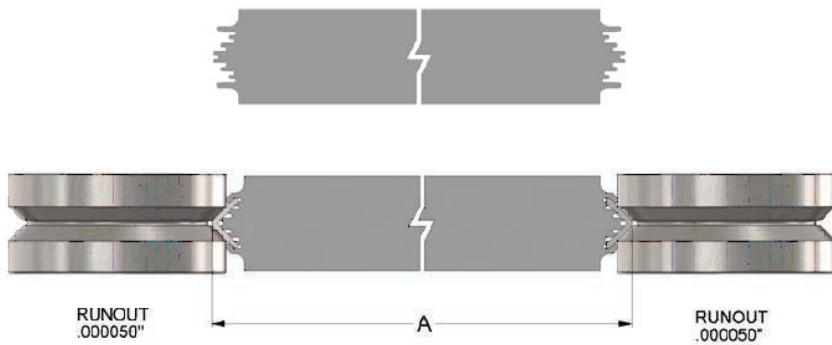

◀ **Fig. 15:** The supporting structure for the IVT v-races.

◀ **Fig. 16:** IVT v-races being swaged into place.

During manufacturing of an IVT rail, the supporting structure for the v-races is first machined into the aluminum substructure using PBC Linear’s SIMO® process.

The final assembly tolerances for IVT rails are controlled by rollers that simultaneously press the steel v-races in place during manufacturing. This provides some of the same inherent tolerance advantages as the simultaneous grinding used to produce steel profile rails, but at a much lower cost.

The IVT product allows great design flexibility as the IVT raceways can be built into an endless variety of structural shapes. Standard configurations are available that fit a variety of size envelopes, load capacities, and mounting arrangements. Rail designs are available to conform to the same size envelope as steel profile rails. Custom IVT shapes and carriages have been exclusively supplied to particular customers. Such designs have allowed those customers to reduce the part count, the fastener count, and the assembly labor of their designs.

When an IVT rail with dual raceways is fastened in place, it will be influenced by the flatness and straightness of the mounting surface(s) to which it is attached. However, the raceways remain precisely spaced from each other as they follow the irregularities of the mounting surface. The machined parallelism of the rails promotes smoother carriage travel than if the individual raceways were each located separately.

IVT systems have an innate ability to operate in dirty environments. The wiping action of the v-roller on the rail tends to sweep debris from the rail surface. The rotation of a roller creates centrifugal force which flings off most types of debris that tries to stick to the roller. Finally, the large diameter of the v-roller allows it to roll over debris if necessary. The sealed and permanently lubricated bearings of the IVT v-rollers are isolated from dirty environments. PBC Linear can be contacted regarding plated raceways or stainless steel raceways for harsh environments.

The IVT linear guidance system has several advantages:

- The number of fasteners for a dual IVT system is one half or less than the number of fasteners necessary in a bearing block system with two separate rails that must be aligned and screwed in place.
- Custom IVT designs can be created that combine parallel steel raceways with a custom structural member allowing a user to drastically reduce their part count and fastener count.
- IVT rollers have sealed bearings and the v-rollers large diameters are able to operate effectively in dirty environments.

The IVT product allows great design flexibility as the IVT raceways can be built into an endless variety of structural shapes.

Cost Comparison of the Systems

Assume the bearing block system will require a machined base plate, two parallel rails, (4) bearing blocks and a carriage plate. Assume the IVT system will require an integrated dual raceway rail and a pre-assembled carriage. Bearing block systems require the user to design the carriage while pre-designed and manufactured carriages are offered for the IVT product line.

1. Designing the System

Designing a linear guide system can take hours of engineering and drafting time. Obviously, the time involved could vary widely depending on the complication of the design. However, it is not a cost factor that should be overlooked so a simple estimate was made.

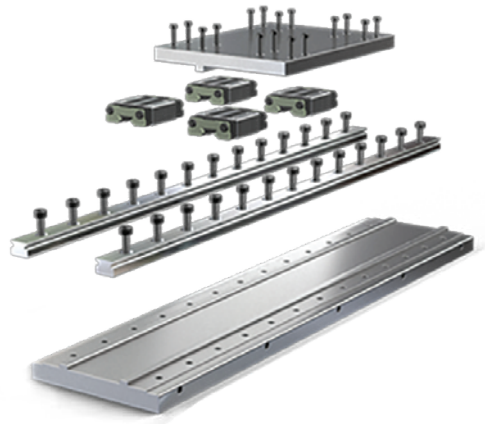

Fig. 14: Components of a Bearing Block System.

	Bearing Block System	IVT System
Design Steps	Labor (min)	Labor (min)
1. Select and source components	30	10
2. Download model/drawings	5	5
3. Design carriage	60	0
4. Build and cost BOM	25	10
5. Manufacture/procure carriage	20	20
6. Manufacture/procure rail	20	20
7. Quality assurance	20	5
Total Time (hours)	3 hours	1.17 hours
Design Cost Sub-total (\$60.00/hour)	\$184.80	\$70.20

2. Material Costs

A bearing block system requires many more components than an IVT system.

Bearing Block and Steel Profile Rails		
Product	Quantity	Cost
15mm Rail	2	\$99.75
15mm Carriages	4	\$226.80
Carriage Plate	1	\$10.00
Mounting Plate Assy	1	\$16.34
Fasteners	56	\$0.13
Material Cost Subtotal:		\$353.02
IVT BOM		
Product	Quantity	Cost
IVTAAFR	1	\$71.60
Carriage Assy	1	\$113.17
Fasteners	26	\$0.13
Material Cost Subtotal:		\$184.90

A bearing block system requires many more components than an IVT system.

3. Installation Labor

	V-roller System	Bearing Block System	IVT System
Design Steps	Labor (min)	Labor (min)	Labor (min)
Drill/tap machine plate	10	10	10
Clean/align rail with reference surface	30	30	N/A
Loosely fasten rail to machining surface	10	10	N/A
Secure side plates	10	10	N/A
Repeat steps for secondary rail	50	50	N/A
Securely fasten system	10	10	15
Total Installation Time:	120	120	25
Assembly Cost Sub-total (\$35.00/hour)	\$70.00	\$70.00	\$14.60

Cost Comparison Results

- i. Bearing Blocks = \$184.80 + \$353.02 + \$70.00 = **\$607.82**
- ii. IVT = \$70.20 + \$184.90 + \$14.60 = **\$269.70**

The above estimates are approximate but the bearing block and profile rail system was found to be 2.2 times higher in cost than an IVT system.

CONCLUSION

Both IVT and profile rail systems are precision products. The potential accuracy of an IVT system is slightly less than that of a bearing block system with ground steel profile rails, but in many applications IVT systems can be used successfully at a fraction of the cost. In some applications, the IVT systems have performance advantages. For instance when profiled steel rails are not accurately aligned and handled during installation, the accuracy and smoothness of travel for a dual raceway IVT system can be better than that of a bearing block system. And in applications where debris is present, IVT rollers often provide smoother travel and longer life than bearing block systems. The design flexibility of the IVT system lends itself to custom designs that minimize a user's part count, assembly labor, and assembly time. Such design advantages often help to reduce a new product's design time and speed its introduction to the marketplace.

The estimates are approximate but the bearing block and profile rail system was found to be **2.2 times higher in cost** than an IVT system

Further Information

If you're still having difficulties, contact a PBC Linear Application Engineer to discuss your application. You can contact an engineer directly by calling 1.800.962.8979 (from within the USA) or +1.815.389.5600 (from outside the USA). If you prefer, e-mail an engineer at: appeng@pbclinear.com

References

- 1 *Aluminum Extrusion Manual, 3rd Ed.* on CD ROM (Aluminum Extruders Council and the Aluminum Association, 2003), Section 8, p.8
- 2 *Design for Manufacturability Handbook*, ed. James G. Bralla (McGraw Hill, 1986) p. 130
- 3 Tedric A. Harris and Michael N. Kotzalas, *Essential Concepts of Bearing Technology* (CRC Press: Taylor and Francis Group, 2007) p.136

Version

This is version 2 of the published white paper. It has been updated 21 August 2019.

© 2019 PBC Linear™, A Division of Pacific Bearing Company



WORLDWIDE HEADQUARTERS

PBC Linear, A Pacific Bearing Co.

6402 E. Rockton Road, Roscoe, IL 61073 USA

Toll-Free: +1.800.962.8979 sales@pbclinear.com

Office: +1.815.389.5600 www.pbclinear.com

Fax: +1.815.389.5790

EUROPEAN HEADQUARTERS

PBC Linartechnik GmbH, A Pacific Bearing Co.

Niermannsweg 11-15, D-40699 Erkrath, Germany

Office: +49.211.416073.10 info@pbclinear.eu

Fax: +49.211.416073.11 www.pbclinear.eu

CHINA HEADQUARTERS

PBC-Moons

168 Mingjia Road, Minhang District, Shanghai 201107 P.R. China

Tel: +86 21 52634688 info@moons.com.cn

Fax: +86 21 52634098 www.moons.com.cn

PBC Linear has a global network of distributors with thousands of locations worldwide.

Visit pbclinear.com to find a distributor near you.