

SOLUTIONS FOR POWER TRANSMISSION

Ixiflex[®] coupling

JAURE[®]



EMERSON[™]
Industrial Automation

JAURE®.

Experience, innovation
and close cooperation
with leading international
companies.

JAURE S.A. is a leading supplier of couplings and power transmission solutions. Experience, manufacturing program, innovation and close cooperation with leading International companies in the business enables JAURE® to provide customized solutions to our customers.

For 50 years, JAURE® has developed couplings for the most demanding applications in marine, wind energy, steel, railway and paper industries among others.

Our manufacturing program covers a complete range without boundaries in power and speed, and we continue developing new products for future challenges.

JAURE S.A. is part of Emerson Industrial Automation. The integration has strengthened JAURE's brand presence worldwide and has added application expertise to provide answers, products and service to our customers on a global basis.

Ixiflex® coupling

IXILFLEX® flexible coupling was first introduced in windturbines. It has been making inroads for 10 years on other industries such as marine propulsion, industry, railway and other specific applications like test benches.

IXILFLEX® is a link type coupling which absorbs misalignment through bushes linked to alternate flanges. These bushes are produced through the vulcanisation of rubber to metal parts under high precompression.

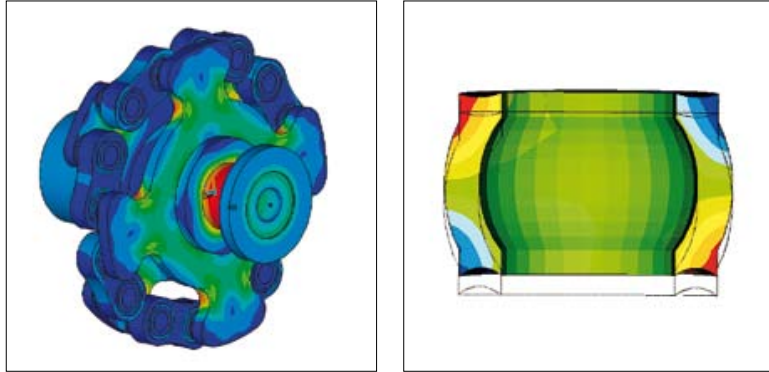

FEA of Ixiflex®coupling and rubber bushing.

The main advantages of IXILFLEX® couplings are:

- High misalignment capability: absorb higher axial and radial misalignment than conventional flexible couplings, with very low restoring forces
- High torque capability
- Bidirectional coupling: IXILFLEX® can operate cw and ccw with no need to reverse it. Therefore, it is a trouble-free installation design.
- Silent operation: transmitted noise is reduced.
- Torsional damping capability.
- Electrically insulated.
- Easy visual inspection and and replacement of flexible elements.
- Fail-safe design.



Ixiflex couplings meet the requirements of classification societies and are on demand delivered with the official certificates.

In addition to our R+D+i department validation procedures, IXILFLEX® couplings are analysed by specific software which is based on FEA. JAURE® also collaborates with technological centres, that combined with our worldwide network of technical experts, enables us to provide innovative engineered solutions to our customers.

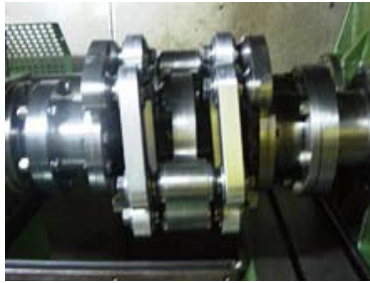

Misalignment fatigue testing.

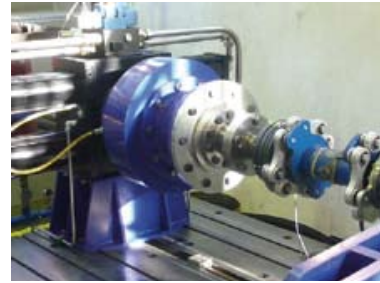

Torque fatigue testing.

Thousands of IXILFLEX® couplings are successfully operating in various applications. A wide product is available at Jaure to meet each project needs. Our brand names are recognized worldwide in the market:

- **JSS** steel conventional shaftlines
- **JCFS** low weight carbon fibre shaftlines for long spans
- High electrically insulated **JGFS** glass fibre shaftlines



Coupling selection

Different combinations allow engineered to order solutions for each project. But IXILFLEX® couplings are also supplied as standardized products.

The selection procedure is as follows:

$$T_n \geq \frac{9,55 \cdot P \cdot SF_t}{n}$$

T_n = IXILFLEX® nominal torque (kNm)

P = Transmitted Power (kW)

n = Speed (rpm)

SF_t = Temperature service factor (refer to Chart 1) For temperatures above 75°C, please contact JAURE®

The torque and speed ratings shown on the catalogue include the corresponding safety factors. But for critical applications (i.e. with frequent peak torques or long spans), additional service factors may be required and coupling selection must be confirmed by JAURE®.

Selection example

Power: 1200 Kw

Speed: 1500 rpm

Nominal torque:

$$T_n \geq \frac{9,55 \cdot 1200 \cdot 1}{1500} = 7,64 \text{ kNm}$$

Selected coupling designation is:

IXILFLEX® 480 – DBSE 625mm

Peak torque: 11,46 kNm

Continuous operation temperature: 40°C

Distance between shaft ends: 625 mm

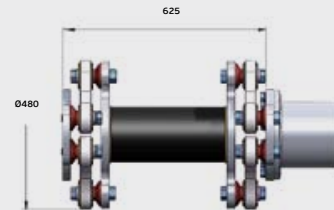

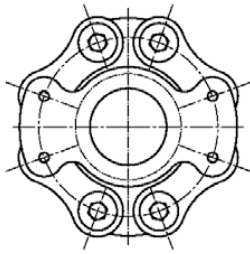

4 link design

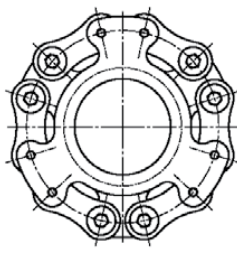

6 link design

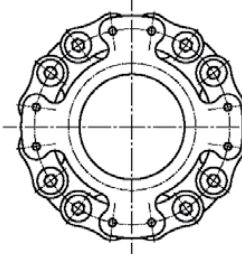

8 link design

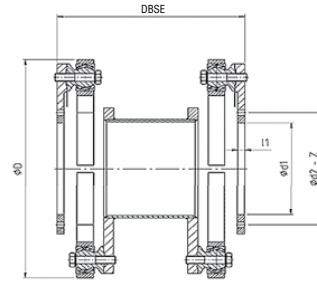

Ixilflex® Coupling

IXILFLEX size	Nominal Torque Tn [kNm]	(1) Max. Torque Tp [kNm]	(2) Max. Speed n [r.p.m.]	DIMENSIONS [mm.]					T	Weight m [kg]	Inertia J [kgm ²]	(4) Max. Axial misalignment ±Ka [mm.]	(5) Max. Angular misalignment ±Kw [deg]
				D	d1	d2 - Z	(3) DBSE	l1					
390	7	14	2690	390	155	190 - 8	400	20	4	49	0,9	12,5	4,0
480	9	18	2180	480	210	245 - 8	400	20	4	58	1,3		
510	11,5	23	2050	510	210	245 - 8	400	20	4	61	2,0		
495	14	28	2120	495	210	245 - 12	500	27	4	102	3,4	25,0	2,5
545	15,5	31	1920	545	225	270 - 12	500	27	4	118	4,0		
634	28,5	57	1650	634	280	310 - 12	500	27	6	307	19,5		
740	34,5	69	1410	740	300	345 - 16	500	27	6	355	22,4		
750	48	96	1400	750	300	345 - 16	600	36	4	475	43,4		
800	50,5	101	1310	800	310	385 - 16	600	27	8	440	28,0		
810	79	158	1290	810	310	385 - 16	600	36	6	547	50,0		
850	84	168	1230	850	310	385 - 16	600	36	6	602	56,0		
1006	103	206	1040	1006	420	515 - 24	750	36	6	690	64,4		
1020	140	280	1020	1020	420	515 - 24	750	36	8	800	80,1		
1096	153	306	950	1096	500	600 - 24	750	36	8	876	88,1		
1300	186	372	800	1300	700	800 - 24	750	36	8	964	96,9		

Larger sizes are available on demand.

- 1 Max. Torque Tp** may occur in transient operation during limited time (i.e. start-up or shock condition).
- 2 Max. Speed n** could be limited by the weight and whirling speed of the spacer. For higher speeds, please contact JAURE®.
- 3 Dimension DBSE** is the distance between shaft ends and is a variable parameter.
- 4 Max. Axial misalignment** per 2 joints. The indicated values are maximum ones on transient operation. For combined Axial and Angular misalignment, please refer to chart 2. For continuous or higher misalignment values, please contact JAURE®.
- 5 Max. Angular misalignment** per single joint. The indicated values are maximum ones on transient operation. For combined Angular and Axial misalignment, please refer to chart 2. For continuous or higher misalignment values, please contact JAURE®.

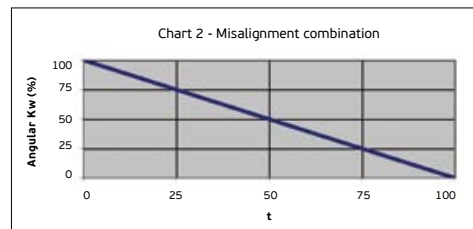
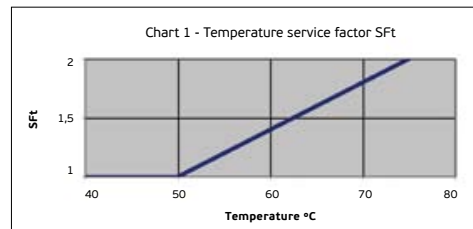

JAURE® reserves the right to make technical modifications in this catalogue without notice and no liability can be accepted for updating previously supplied components.

Ixilflex® designs

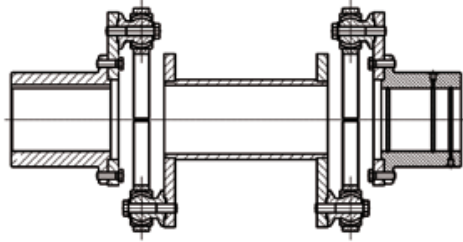

Type IX: Standard design with B01 keyway & E01 shrink fit shaft connections.

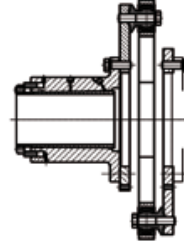

Type IU: Single joint design with JHC hydraulic shaft coupling.

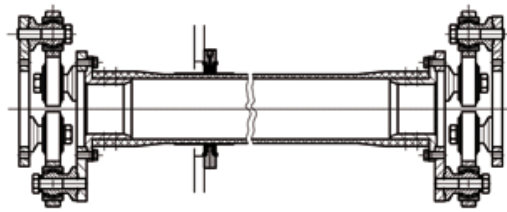

Type IX-JCFS: With carbon fibre spacer and bulkhead-seal.

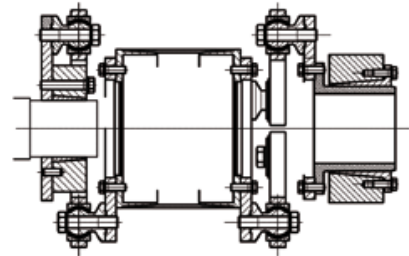

Type IX-JGFS: With glass fibre spacer and G03 clamping ring.

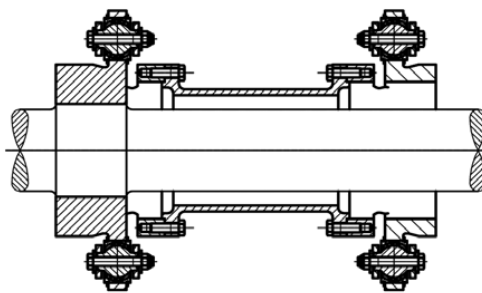

Type IX-FE: Special design for railway.

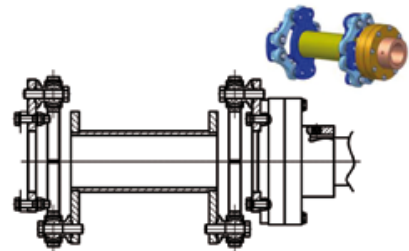

Type IX-JFTL: With torque limiter and B01 keyway connection.

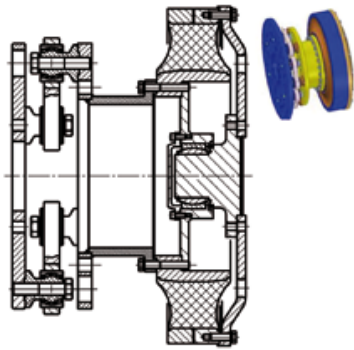

Type IU-HEC: Single joint combined with torsionally flexible coupling.

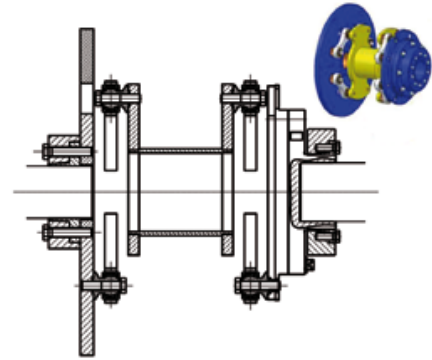

Type IX-JFTL-FD: With torque limiter and brake disc. G03 clamping rings.

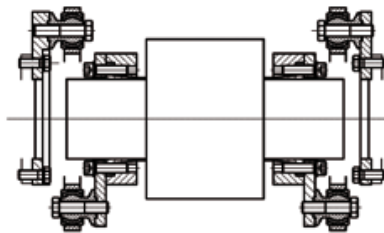

Type IX-TM: With torque measuring equipment.

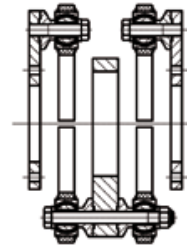

Type IX-SC: For short distance connection.

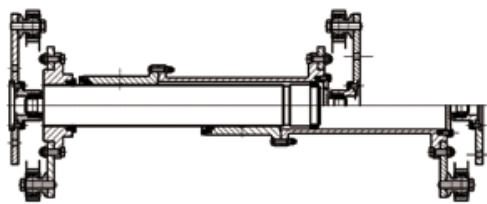

Type IX-CO: Telescopic, for axial stroke.

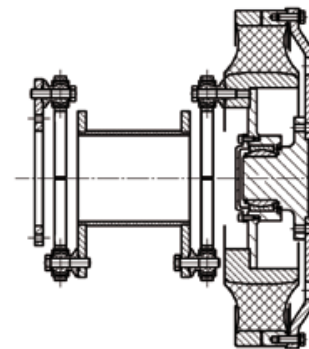

Type IX-HEC: High misalignment combined with torsionally flexible coupling.

Ixilflex® references

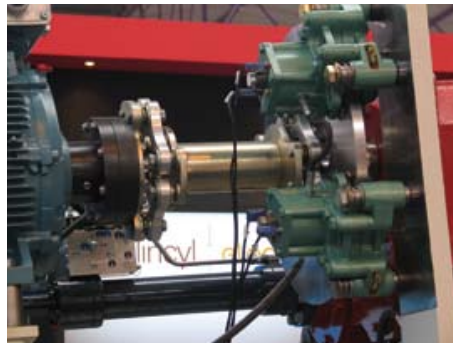

Ixilflex® with torque limiter.



Ixilflex® in waterjet applications.



Ixilflex® for railway.



Ixilflex® couplings with steel spacer.



Ixilflex® for test bench.



Ixilflex® in wind turbine.

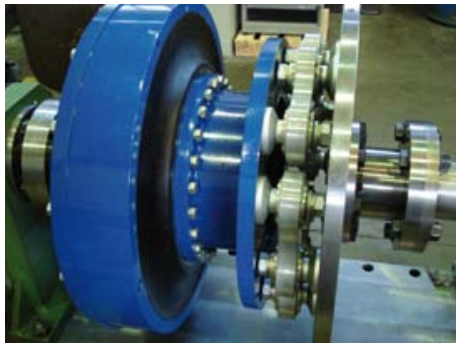

Ixilflex® combined with a highly elastic coupling.

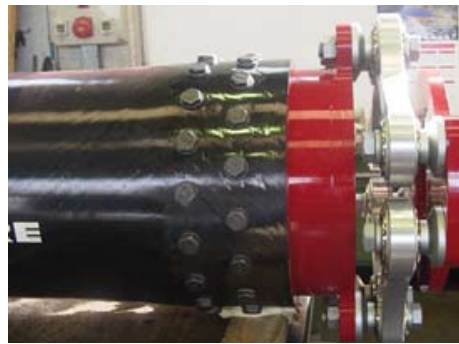

Ixilflex® with JCFS composite spacer.



Ixilflex® during installation.



Ixilflex® on test bench.



Ixilflex® for high corrosion environment.



Ixilflex® with JGFS composite spacer.

Jaure manufacturing program



Product Brand Name	MT	LAMIDISC®	TCB / TCB-S	AL-S / AL-SD / ALD	RECORD
Type & Description	Gear	Disc pack	Barrel (drum type)	Gear spindles	Grid / spring type

INDUSTRY APPLICATION					
Metals & Heavy duty	•	•	•	•	•
Minerals & Mills	•	•	•		•
Crane & Hoisting	•	•	•		•
Pulp & Paper	•	•			•
Petrochemical / Oil & Gas	•	•			•
Cooling Towers		•			
Machine Tools		•			
Marine	•	•	•		
Wind Turbines		•			•
Test Benches	•	•			
Railway	•	•			



Special safety heavy duty gas nitrided gears



LAMIDISC® Safety coupling on test bench Incl. SAFESET® (SAFESET® from VOITH TURBO)



Type Approvals (Marine & Wind).

COUPLINGS



JAUFLEX®

IXILFLEX®

COMPOLINK®

JFTL TORQUE LIMITER

JCFS

JHC

Elastic

Elastic Link

Composite Link

Torque Limiter

Composite Shafts

Hydraulic fit (shaft couplings)

•			•		•
•			•		•
•			•		
•	•	•		•	
•		•		•	
		•		•	
•		•		•	
•	•	•	•	•	•
•	•	•	•	•	•
	•	•		•	•
	•	•	•		



Carbon Fibre Shaft combined with LAMIDISC® coupling.



Torque monitoring on wind turbines.



Double-gear couplings for railway.

Kop-Flex & Jaure manufacturing program

COUPLINGS



Product Brand Name	MAX-C [®]	HIGH PERFORMANCE PROGRAM			KOPFLEX GREASE	SERVICE
Type & Description	Heavy duty elastic coupling	GEAR	DISC	DIAPHRAGM	Gear coupling / spindle grease	Repair & maintenance program

INDUSTRY APPLICATION						
Metals & Heavy duty	•				•	•
Minerals & Mills	•				•	•
Crane & Hoisting	•				•	•
Pulp & Paper					•	•
Petrochemical / Oil & Gas	•	•	•	•	•	•
Cooling Towers					•	•
Machine Tools					•	•
Marine	•	•	•	•	•	•
Wind Turbines	•				•	•
Test Benches	•	•	•	•	•	•
Railway	•	•			•	•

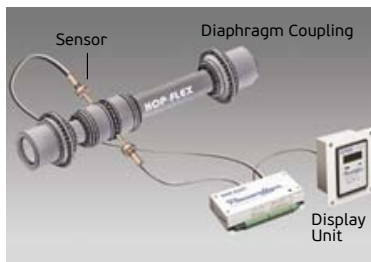

Powerlign[®] Torque Monitoring.



High Performance Solutions.

Global presence

MANUFACTURING FACILITIES & ENGINEERING CENTERS



JAURE® & KOP-FLEX® engineered couplings are designed, manufactured, sold and serviced worldwide, with service provided from specification right through to installation.

All JAURE® & KOP-FLEX® facilities around the globe are state of the art, with access to a large and

experienced engineering staff focused on providing solutions for our customers' requirements.

A dedicated global sales and service team assists you to find the best choice and manage all your coupling needs.



JAURE®. Zizurkil. Spain.



Pune, India.



Nove Mesto, Slovakia.



Zhangzhou, China.



KOP-FLEX®. Baltimore, USA.



Rexdale / Toronto, Canada.



Apocadaca, México.

JAURE®

JAURE S.A.
Ernio bidea, s/n
20159 ZIZURKIL
(Gipuzkoa) SPAIN

Phone: +34 943 69 00 54
Fax: +34 943 69 02 95

e-mail: infojaure@emerson-ept.com
www.jaure.com
www.kopflex.com



Browning

JAURE

KOP-FLEX

McGILL

Morse

ROLLWAY

SEALMASTER

SYSTEM™
PLAST

APPLICATION CONSIDERATIONS: The proper selection and application of power transmission products and components, including the related area of product safety, is the responsibility of the customer. Operating and performance requirements and potential associated issues will vary appreciably depending upon the use and application of such products and components. The scope of the technical and application information included in this publication is necessarily limited. Unusual operating environments and conditions, lubrication requirements, loading supports, and other factors can materially affect the application and operating results of the products and components and the customer should carefully review its requirements. Any technical advice or review furnished by Emerson Power Transmission Corporation and its divisions with respect to the use of products and components is given in good faith and without charge, and Emerson assumes no obligation or liability for the advice given, or results obtained, all such advice and review being given and accepted at customer's risk. For a copy of our Standard Terms and Conditions of Sale, Disclaimers of Warranty, Limitation of Liability and Remedy, please contact Customer Service at 1-800-626-2120. These terms and conditions of sale, disclaimers and limitations of liability apply to any person who may buy, acquire or use an Emerson Power Transmission Corporation product referred to herein, including any person who buys from a licensed distributor of these branded products.

Morse is a registered trademark of Borg-Warner Corporation, used herein under exclusive license. Browning, Compolink, Emerson, Emerson Industrial Automation, Ixiflex, Jaure, Kop-Flex, Lamidisc, McGill, Sealmaster and System Plast are trademarks of Emerson Electric Co. or one of its affiliated companies.

©2010 Emerson Power Transmission, All Rights Reserved. MCB10007 - Form 9335