

Janome 525S Instruction Manual

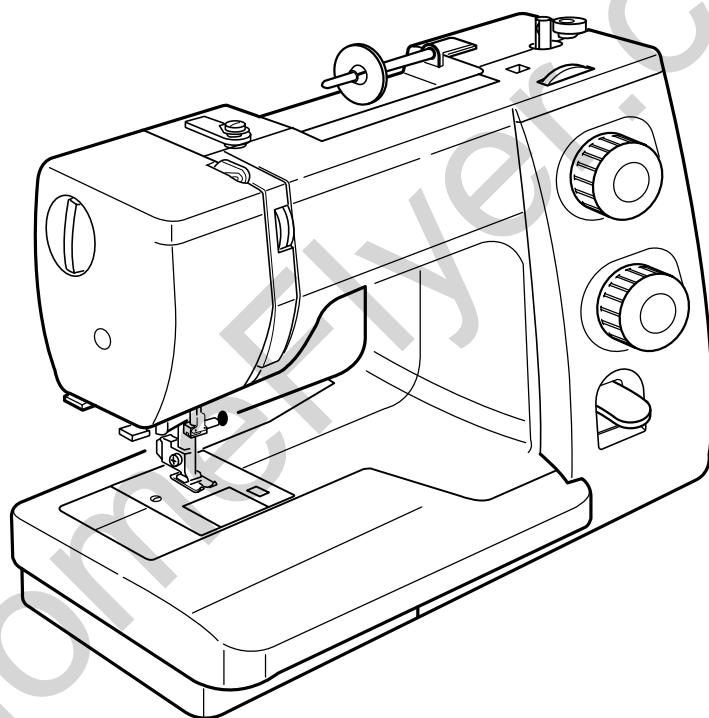

Model 525S

IMPORTANT SAFETY INSTRUCTIONS

When using an electrical appliance, basic safety precautions should always be followed, including the followings:

Read all instructions before using this appliance.

DANGER— To reduce the risk of electric shock:

1. An appliance should never be left unattended when plugged in. Always unplug this sewing machine from the electric outlet immediately after using and before cleaning.
2. Always unplug before replacing a sewing machine bulb. Replace bulb with same type rated 15 Watts.

WARNING— To reduce the risk of burns, fire, electric shock, or injury to persons:

1. Do not allow children to play with the machine. The machine is not intended for use by children or infirmed persons without proper supervision.
Do not allow to be used as a toy. Close attention is necessary when this sewing machine is used by or near children.
2. Use this appliance only for its intended use as described in this owner's manual.
Use only attachments recommended by the manufacturer as contained in this owner's manual.
3. Never operate this sewing machine if it has a damaged cord or plug, if it is not working properly, if it has been dropped or damaged, or dropped into water.
Return this sewing machine to the nearest authorized dealer or service center for examination, repair, electrical or mechanical adjustment.
4. Never operate the appliance with any air opening blocked. Keep ventilation openings of this sewing machine and foot controller free from accumulation of lint, dust and loose cloth.
5. Never drop or insert any object into any opening.
6. Do not use outdoors.
7. Do not operate where aerosol (spray) products are being used or where oxygen is being administered.
8. To disconnect, turn all controls to the off ("O") position, then remove plug from outlet.
9. Do not unplug by pulling on cord. To unplug, grasp the plug, not the cord.
10. Keep fingers away from all moving parts. Special care is required around the sewing machine needle.
11. Always use the proper needle plate. The wrong plate can cause the needle to break.
12. Do not use bent needles.
13. Do not pull or push fabric while stitching. It may deflect the needle causing it to break.
14. Switch this sewing machine off ("O") when making any adjustment in the needle area, such as threading the needle, changing the needle, threading the bobbin or changing the presser foot, and the like.
15. Always unplug this sewing machine from the electrical outlet when removing covers, lubricating, or when making any other adjustments mentioned in this owner's manual.

SAVE THESE INSTRUCTIONS

The design and specifications are subject to change without a prior notice.

TABLE OF CONTENTS

SECTION 1. KNOW YOUR MACHINE

Names of Parts	2
Standard Accessories	3
Accessory storage	3
Extension Table	4
Free-arm sewing	4

SECTION 2. GETTING READY TO SEW

Connecting the Power Supply	5
Controlling the Sewing Speed	5
Reverse Stitch Lever	6
Foot Pressure Dial	6
Dropping the Feed Dog	6
Raising and Lowering the Presser Foot	7
Changing the Presser Foot	7
Removing and Attaching the Foot Holder	7
Changing Needles	8
Needle and Thread Chart	8
Winding the Bobbin	9
Setting the spool	9
Removing the bobbin	9
Winding the bobbin	10
Inserting the bobbin	11
Threading the Machine	12
Needle threader	13
Drawing up the Bobbin Thread	14
Selecting the Stitch Pattern	15
Pattern selector dial	15
Stitch Length Dial	15
Adjusting stretch stitch balance	16
Stitch Width Dial	16
Variable needle position	16
Balancing Needle Thread Tension	17

SECTION 3. BASIC SEWING

Straight Stitch Sewing	18
Changing the sewing direction	18
Finishing sewing	18
Seam guides on the needle plate	19
Turning a square corner	19

SECTION 4. UTILITY STITCHES

Basic Zigzag	20
Overcasting	20
Knit Stitch	21
Tricot Stitch (Multiple Zigzag Stitch)	21
Straight Stretch Stitch	22
Zigzag Stretch Stitch	22
Button Sewing	23
Automatic Buttonhole	24
Adjusting the buttonhole stitch density	26
Corded Buttonhole	27
Manual Buttonhole	28
Zipper Application	30
Blind Hemming	33

SECTION 5. DECORATIVE STITCHES

Decorative Satin Stitches	34
Decorative Stretch Stitches	34
Smocking	35
Quilting	36
Pin Tucking	37
Shell Tucking	37
Fagoting	38
Patchwork	38
Appliqué	39

SECTION 6. CARE AND MAINTENANCE

Cleaning the Hook Race and Feed Dogs	40
Replacing the Bobbin Holder	41
Replacing the Light Bulb	41
Troubleshooting	42

SECTION 1. KNOW YOUR MACHINE

Names of Parts

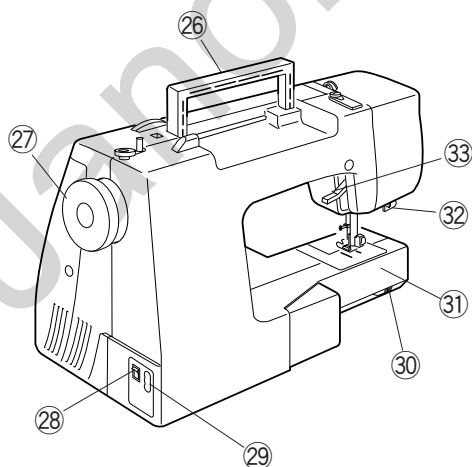
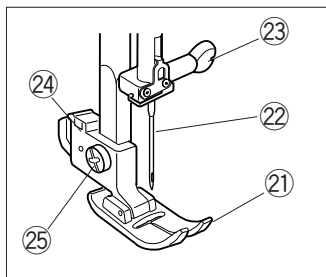
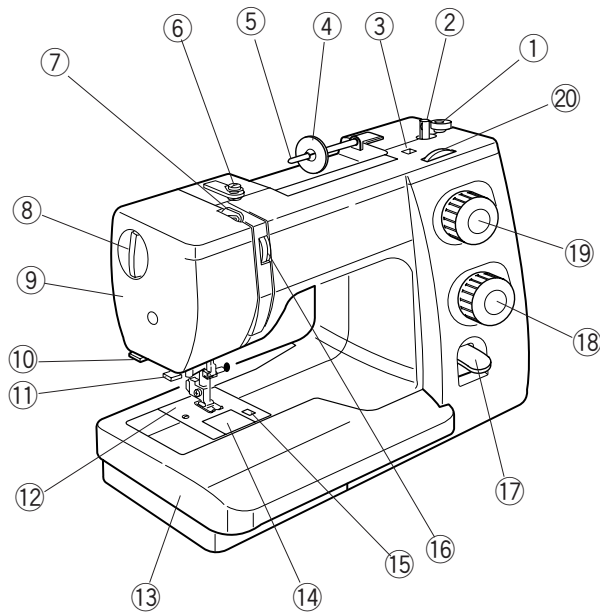

- ① Bobbin winder stopper
- ② Bobbin winder spindle
- ③ Hole for additional spool pin
- ④ Spool holder
- ⑤ Spool pin
- ⑥ Bobbin winder thread guide
- ⑦ Thread take-up lever
- ⑧ Foot pressure dial
- ⑨ Face plate
- ⑩ Thread cutter
- ⑪ Needle threader
- ⑫ Needle plate
- ⑬ Extension table (Accessory storage)
- ⑭ Hook cover plate
- ⑮ Hook cover plate release button
- ⑯ Thread tension dial
- ⑰ Reverse stitch lever
- ⑱ Stitch length dial
- ⑲ Pattern selector dial
- ⑳ Stitch width dial
- ㉑ Presser foot
- ㉒ Needle
- ㉓ Needle clamp screw
- ㉔ Foot holder
- ㉕ Setscrew
- ㉖ Carrying handle
- ㉗ Handwheel
- ㉘ Power switch
- ㉙ Machine socket
- ㉚ Drop feed lever
- ㉛ Free-arm
- ㉜ Buttonhole lever
- ㉝ Foot lifter

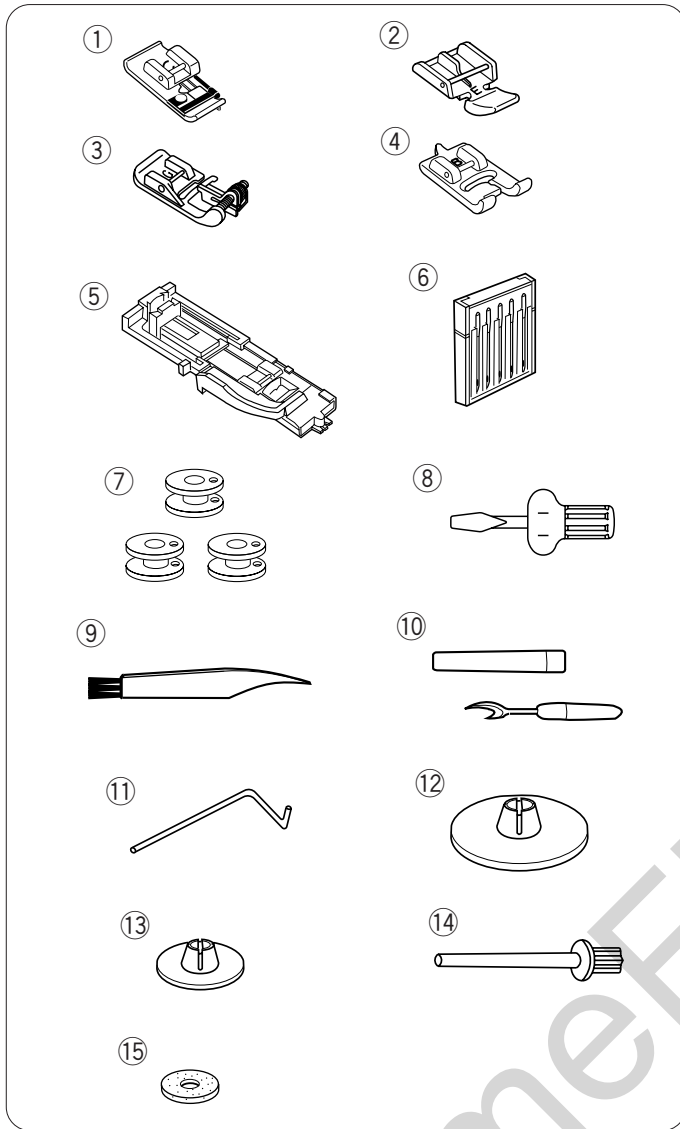

Standard Accessories

- ① Overedge foot C
- ② Zipper foot E
- ③ Blind hemming foot G
- ④ Buttonhole foot B
- ⑤ Automatic buttonhole foot R
- ⑥ Needles
- ⑦ Bobbins
- ⑧ Screwdriver
- ⑨ Lint brush
- ⑩ Seam ripper (buttonhole opener)
- ⑪ Quilting guide
- ⑫ Spool holder (large)
- ⑬ Spool holder (small)
- ⑭ Additional spool pin
- ⑮ Felt cushion

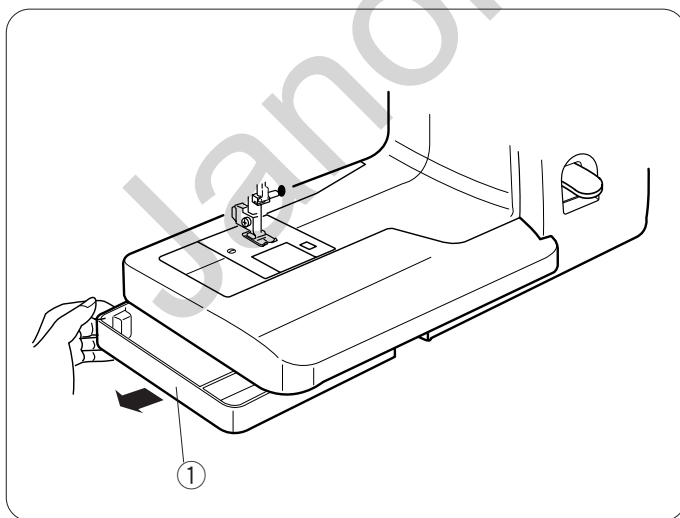

Accessory storage

The standard accessories can be stored in the accessory storage box under the extension table.

Draw out the storage box from the table as shown.

- ① Accessory storage box

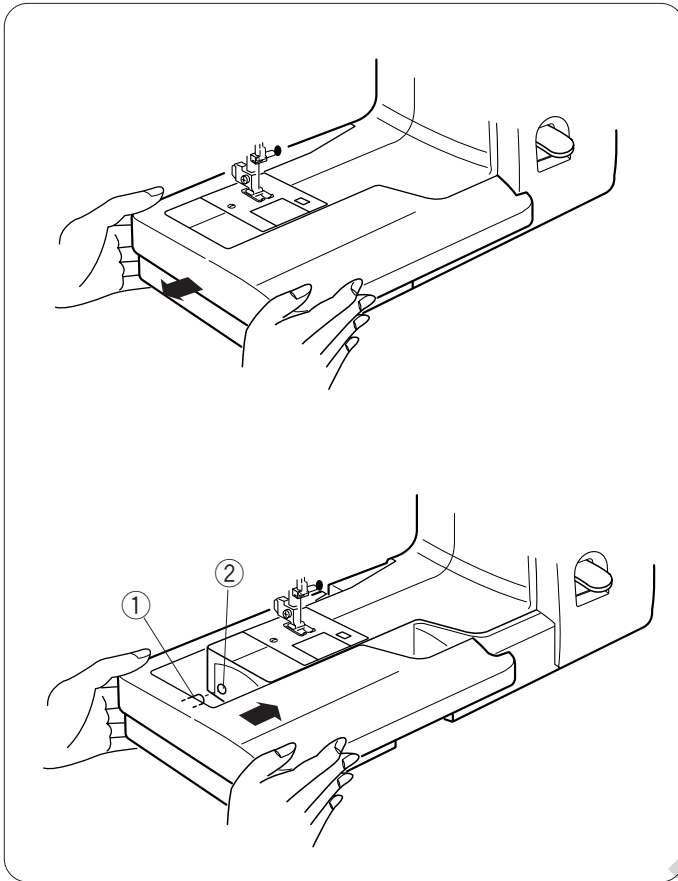

Extension Table

To detach:

Pull the extension table to the left.

To attach:

Insert the pin into the hole and push the extension table to snap it in place.

- ① Pin
- ② Hole

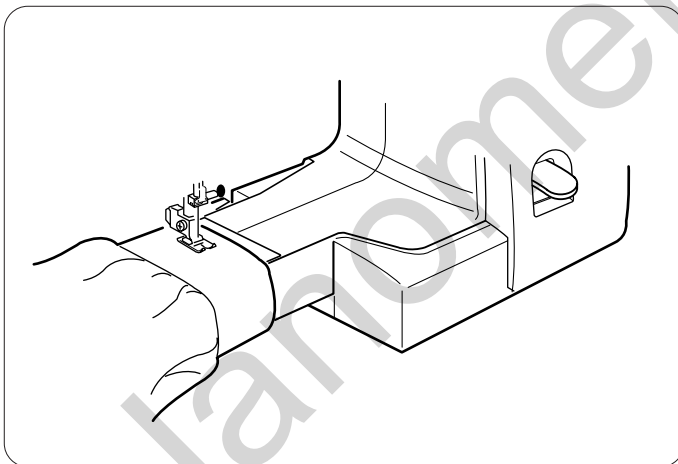

Free-arm sewing

Free-arm sewing is used for stitching sleeves, waistbands, pant legs or any other tubular garments.

It is also useful for darning socks or mending knees or elbows.

SECTION 2. GETTING READY TO SEW

Connecting the Power Supply

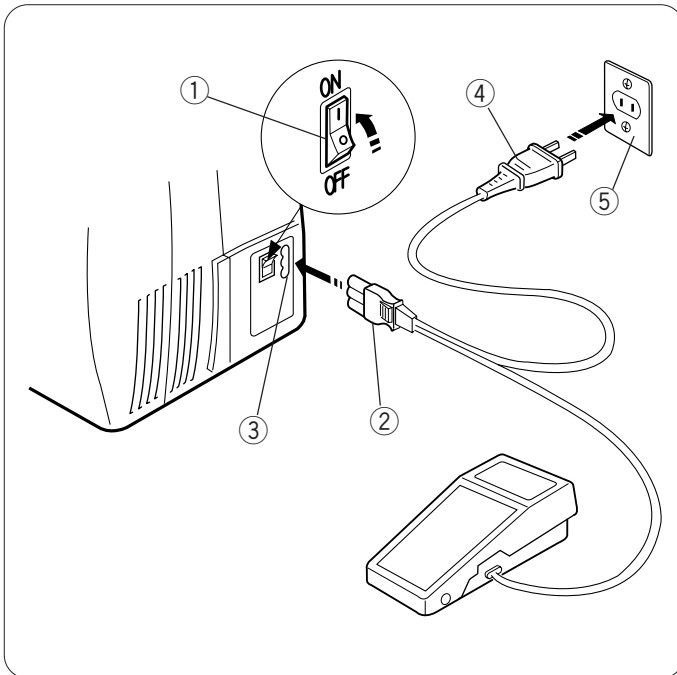

- 1 Turn the power switch off.
- 2 Insert the machine plug into the machine socket.
- 3 Insert the power supply plug into the wall outlet.
- 4 Turn the power switch on.

- 1 Power switch
- 2 Machine plug
- 3 Machine socket
- 4 Power supply plug
- 5 Wall outlet

NOTE:

Before connecting to the power supply, make sure the voltage shown on the machine conforms to your electrical power.

⚠ WARNING:

While in operation, always keep your eyes on the sewing area, and do not touch any moving parts such as the thread take-up lever, handwheel or needle.

Always turn off the power switch and unplug from the power supply:

- when leaving the machine unattended.
- when attaching or removing parts.
- when cleaning the machine.

Do not place anything on the foot control, otherwise the machine will run intermittently.

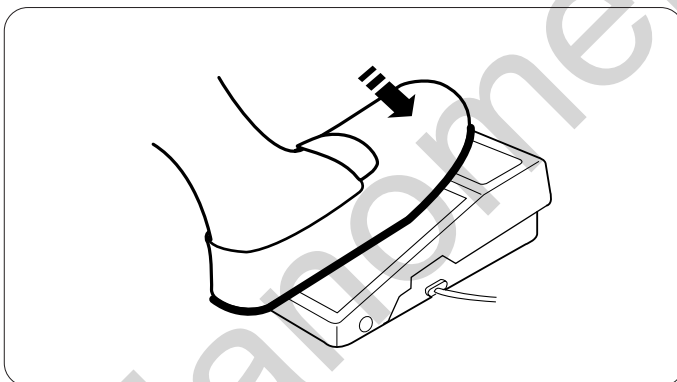

Controlling the Sewing Speed

Foot control

Sewing speed can be varied by the foot control.

The harder you depress the foot control, the faster the machine runs.

Operating Instructions:

The symbol "O" of a switch indicates the "off" position of a switch.

For an appliance with a polarized plug (one blade wider than the other):

To reduce the risk of electrical shock, this plug is intended to fit in a polarized outlet only one way.

If it does not fit fully in the outlet, reverse the plug. If it still does not fit, contact a qualified electrician to install the proper outlet. Do not modify the plug in any way.

The foot controller Model YC-482J or TJC-150 is used with the sewing machine Model 525S (USA market only).

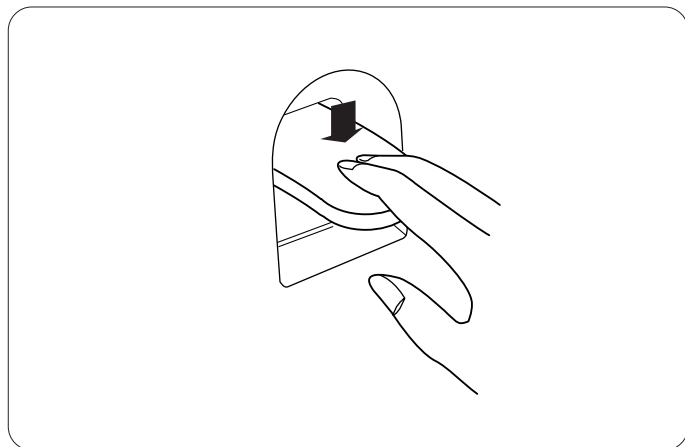

Reverse Stitch Lever

Push the reverse stitch lever down to sew in reverse. The machine will sew in reverse while the lever is pushed.

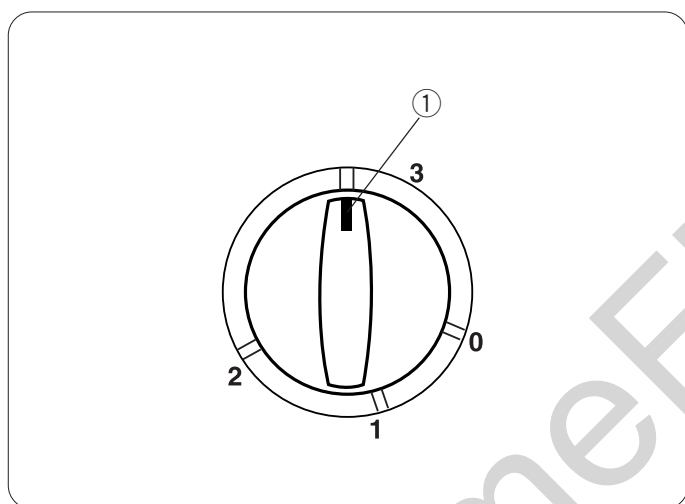

Foot Pressure Dial

Turn the foot pressure dial to adjust the foot pressure. The foot pressure dial should be set at "3" for regular sewing. Reduce the pressure to "2" for appliqué, cutwork, draw work and basting. Set the setting mark at "1" when sewing chiffon, lace, organdy and other fine fabrics.

① Setting mark

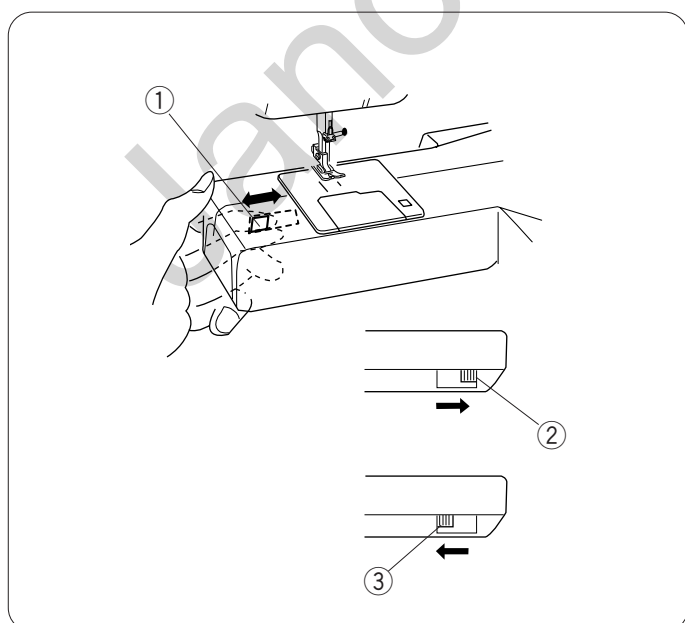

Dropping the Feed Dog

The drop feed lever is located underneath the free-arm bed on the backside of the machine.

To drop the feed dog, push the lever in the direction of the arrow, as illustrated.

To raise the feed dog, push the lever in the direction of the arrow, as illustrated, and turn the handwheel toward you.

The feed dog must be up for regular sewing.

- ① Drop feed lever
- ② Raised position
- ③ Lowered position

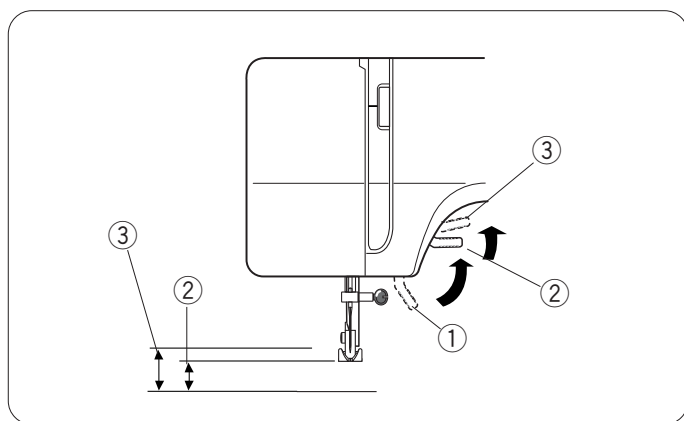

Raising and Lowering the Presser Foot

The presser foot lifter raises and lowers the presser foot.

You can raise the foot about 1/4" (0.6 cm) higher than the normal up position for easy removal of the presser foot, or to help you place heavy fabric under the foot.

- ① Lowered position
- ② Normal up position
- ③ Extra up position



Changing the Presser Foot

To remove:

Raise the needle to its highest position by turning the handwheel counterclockwise. Raise the presser foot, and press the lever on the back of the foot holder.

- ① Lever

⚠ CAUTION:

Turn OFF the power switch before changing the foot. Always use the proper foot for the selected pattern. The wrong foot can cause the needle to break. Do not push the lever down to prevent it from being broken.

To attach:

Place the desired presser foot, so that the pin on the foot lies just under the groove on the foot holder. Lower the presser foot lifter to lock the foot in place.

- ② Groove
- ③ Pin

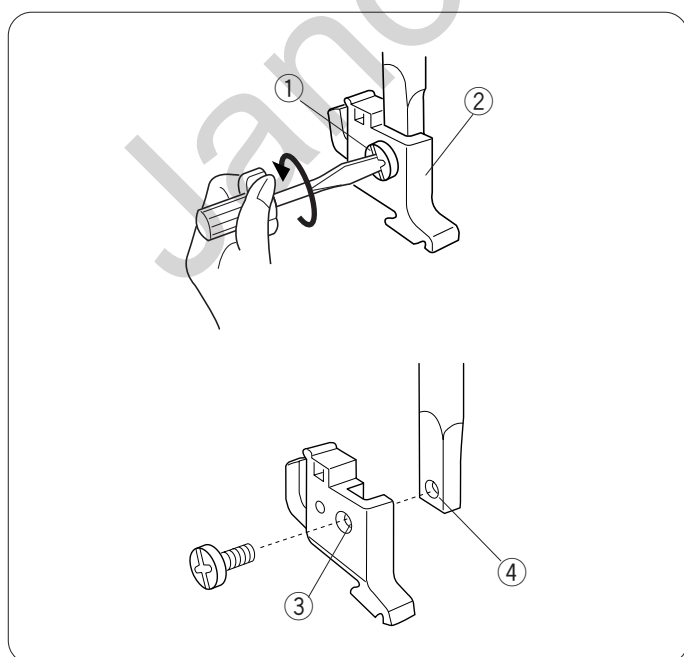

Removing and Attaching the Foot Holder

⚠ WARNING:

Turn OFF the power switch before detaching or attaching the foot holder.

To remove:

Remove the setscrew by turning it counterclockwise with a screwdriver and remove the foot holder.

To attach:

Match the hole in the foot holder with the threaded hole in the presser bar. Fit the setscrew into the hole. Tighten the screw by turning it clockwise with a screwdriver.

- ① Setscrew
- ② Foot holder
- ③ Hole
- ④ Threaded hole

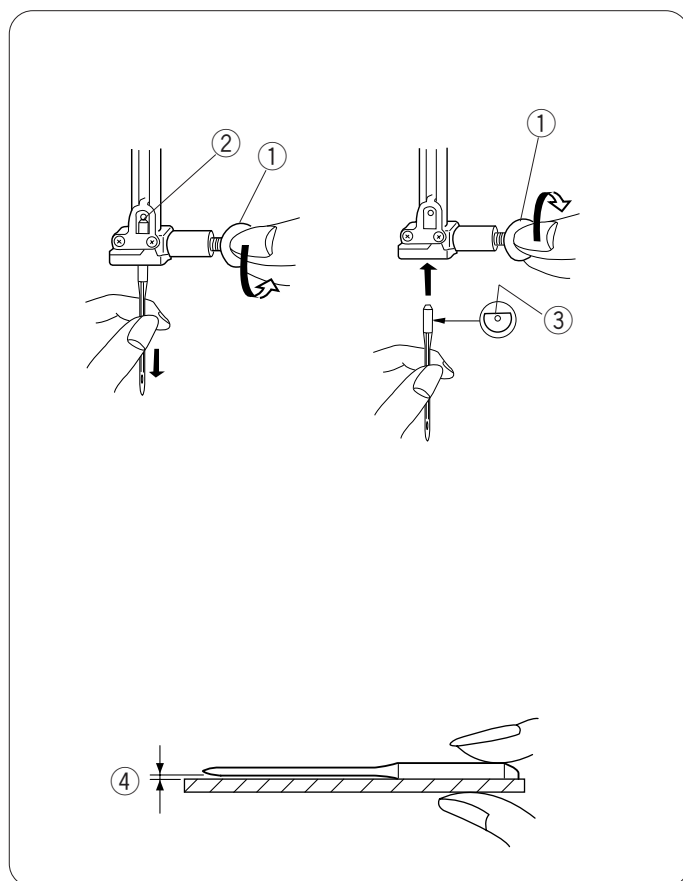

Changing Needles

⚠ CAUTION:

Always make sure to turn the power switch off and disconnect the machine from power supply before changing the needle.

Raise the needle by turning the handwheel and lower the presser foot.
Turn off the power switch.

- 1 Loosen the needle clamp screw by turning it counterclockwise.
Remove the needle from the clamp.
① Needle clamp screw
- 2 Insert a new needle into the needle clamp with the flat side of the needle to the rear.
When inserting the needle into the needle clamp, push it up against the stopper pin and tighten the needle clamp screw firmly.
② Stopper pin
③ Flat side

To check needle straightness, place the flat side of the needle onto something flat (a needle plate, glass etc.) The gap between the needle and the flat surface should be consistent.

Never use a blunt needle.

- ④ Gap

Needle and Thread Chart

WEIGHT	FABRIC	TYPE of NEEDLE	NEEDLE SIZE
Very Light	Chiffon, Georgette, Fine Lace, Organdy Net, Tulle	Universal Ball Point	9 (65) 9 (65)
Light	Batiste, Voile, Lawn, Pure Silk, Crepe de Chine, Sheer Crepe, Chambray, Handkerchief Linen, Gingham, Challis, Percale, Wool Crepe, Peau de Soie, Taffeta, Satin, Silk Surah, Satin-backed Crepe, Qiana	Blue Tipped Needle Universal	11 (75) 11 (75) 12 (80)
	Single Knits, Jersey, Swimwear, and Tricot	Blue Tipped Needle Ball Point	11 (75) 11 (75)
	Leather, Suede	Wedge Point Leather Needle	11 (75)
Medium	Flannel, Velour, Velvet, Muslin, Velveteen, Poplin, Corduroy, Broadcloth, Linen, Chintz, Gabardine, Felt, Terry, Burlap, Quilted Fabrics	Universal	14 (90)
	Double Knits, (synthetic and natural) Stretch Velour, Stretch Terry, Sweater Knits	Ball Point	14 (90)
	Leather, Vinyl, Suede	Wedge Point Leather Needle	14 (90)
Heavy	Denim, Sailcloth, Ticking	Denim Needle	16 (100)
	Double Faced Wool, Heavy Coating, Fake Fur, Drapery Fabrics	Universal	16 (100)
	Leather, Suede	Wedge Point Leather Needle	16 (100) 18 (110)
Very Heavy	Canvas, Duck, Upholstery Fabrics	Universal	16 (100)
Topstitching for Special Finishes		Topstitching Needle	14 (90)

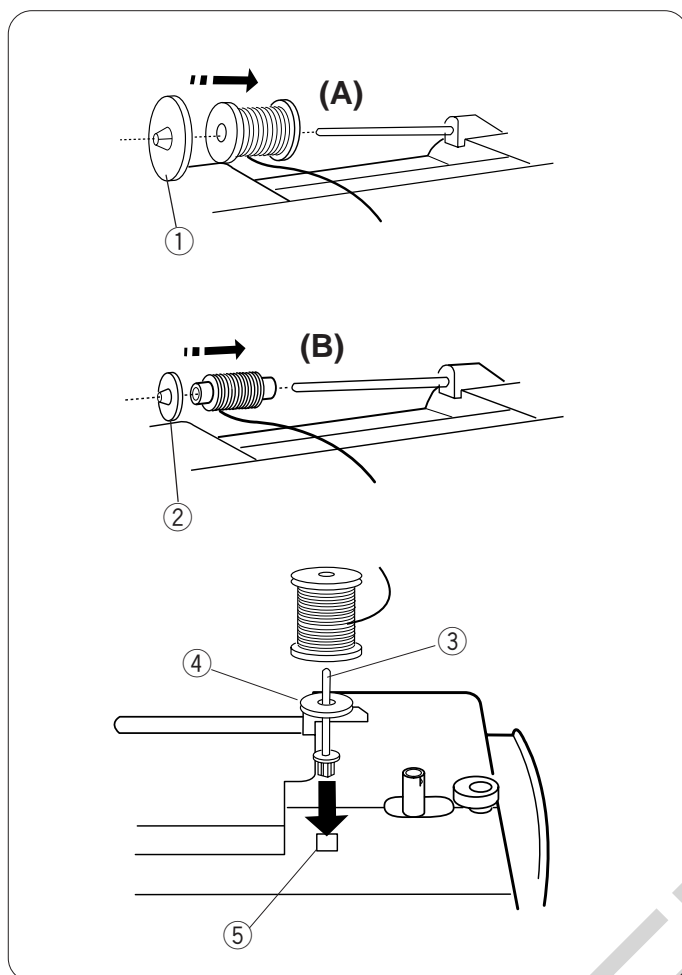

Winding the Bobbin

Setting the spool

Place a spool of thread on the spool pin with the thread coming off the spool as illustrated.

A: Press the large spool holder firmly against the spool of thread.

① Large spool holder

B: For a small spool, use the small spool holder.

② Small spool holder

Additional spool pin

The additional spool pin is for bobbin winding without unthreading the machine.

Insert the additional spool pin into the hole.

Place the felt and a spool on the pin.

③ Additional spool pin

④ Spool pin felt

⑤ Spool pin hole

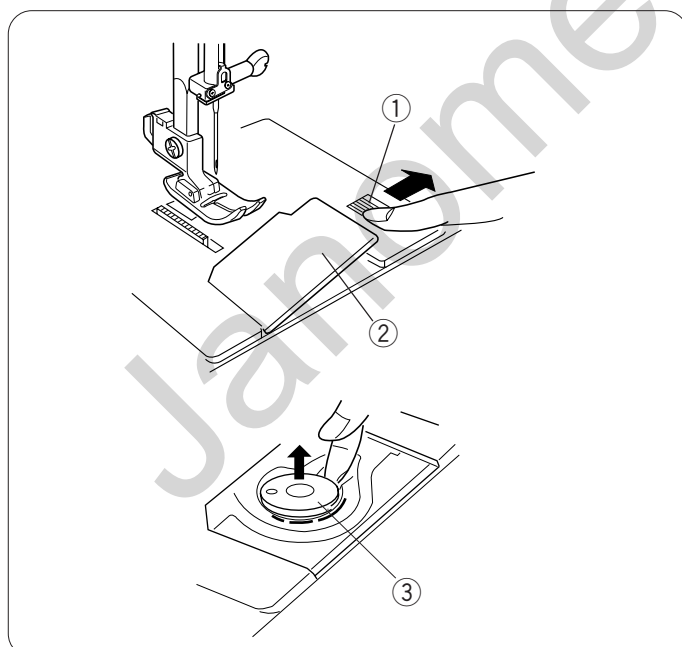

Removing the bobbin

① Push the hook cover plate release button to the right and remove the cover plate.

① Hook cover plate release button

② Hook cover plate

② Lift out the bobbin.

③ Bobbin

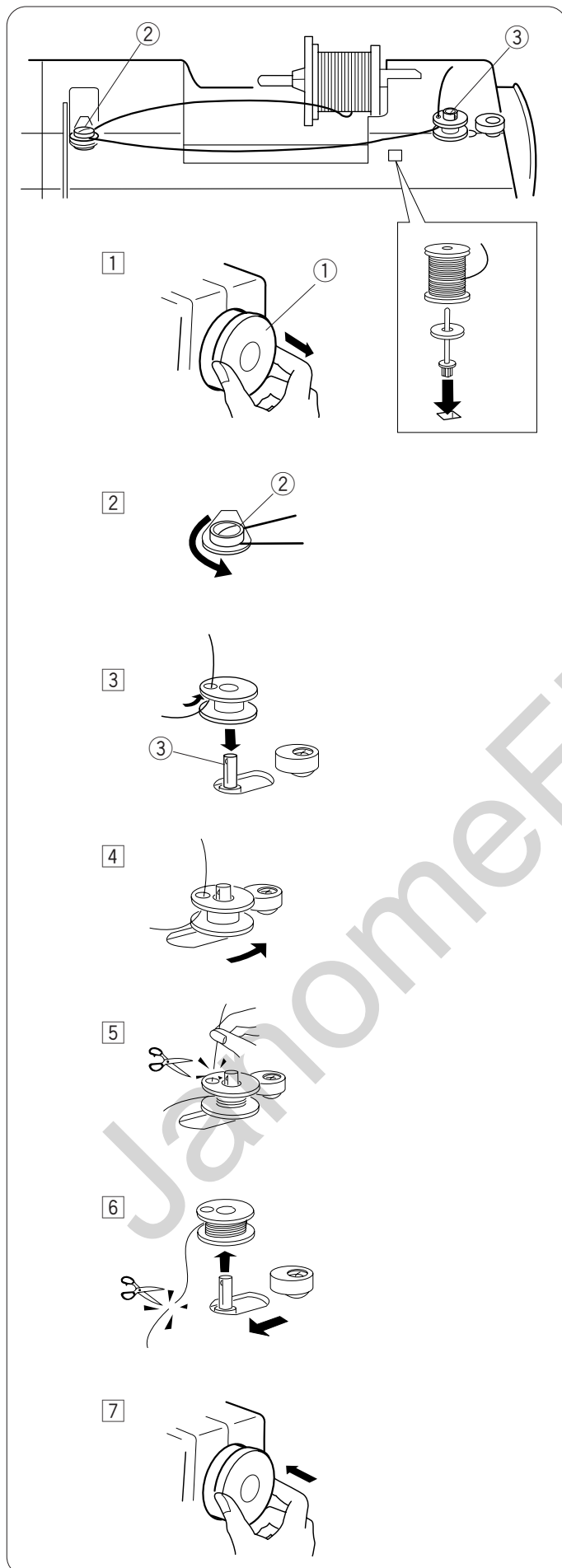

Winding the bobbin

- 1 Pull out the handwheel to disengage the clutch.
 - ① Handwheel

 - 2 Draw the thread from the spool. Guide the thread around the bobbin winder thread guide.
 - ② Bobbin winder thread guide

 - 3 Thread through the hole in the bobbin from the inside to the outside. Put the bobbin on the bobbin winder spindle with the free end of the thread coming out at the top.
 - ③ Bobbin winder spindle

 - 4 Push the bobbin to the right.
- NOTE:**
Do not move the bobbin winder spindle while the machine is running.
- 5 With the free end of the thread held in your hand, depress the foot control. Stop the machine when the bobbin has been wound a few layers, and cut the thread close to the bobbin.

 - 6 Depress the foot control again. When the bobbin is fully wound, it will stop automatically. Return the bobbin winder to its original position by moving the spindle to the left, and cut the thread as illustrated.

 - 7 Push in the handwheel to engage the clutch.

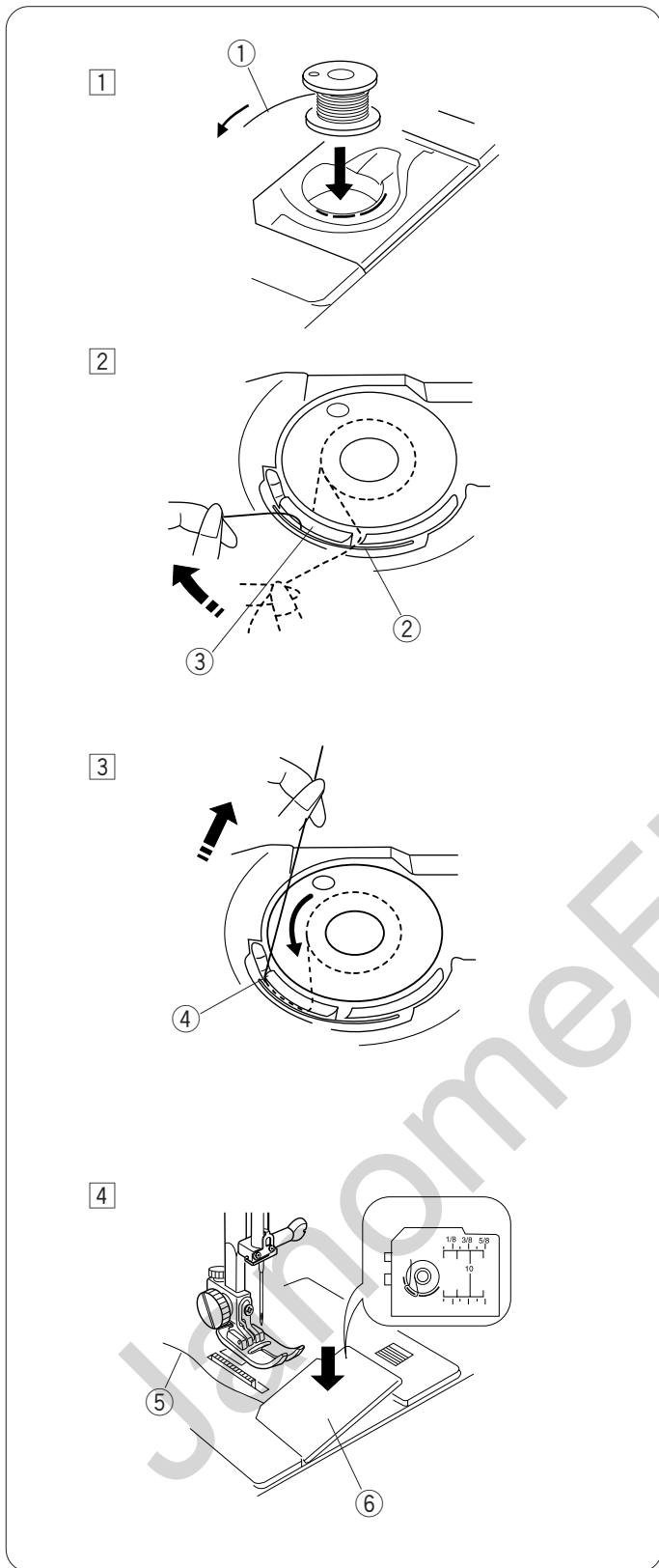

Inserting the bobbin

- 1 Place the bobbin in the bobbin holder with the thread running off as illustrated.
 - 1 Thread

- 2 Guide the thread into the front notch on the front side of the bobbin holder. Draw the thread to the left, sliding it between the tension spring blades.
 - 2 Front notch
 - 3 Tension spring blade

- 3 Continue to draw the thread lightly until the thread slips into the side notch.
 - 4 Side notch

- 4 Pull out about 4" (10 cm) of thread. Attach the hook cover plate. Check the threading by referring to the chart shown on the hook cover plate.
 - 5 Thread
 - 6 Hook cover plate

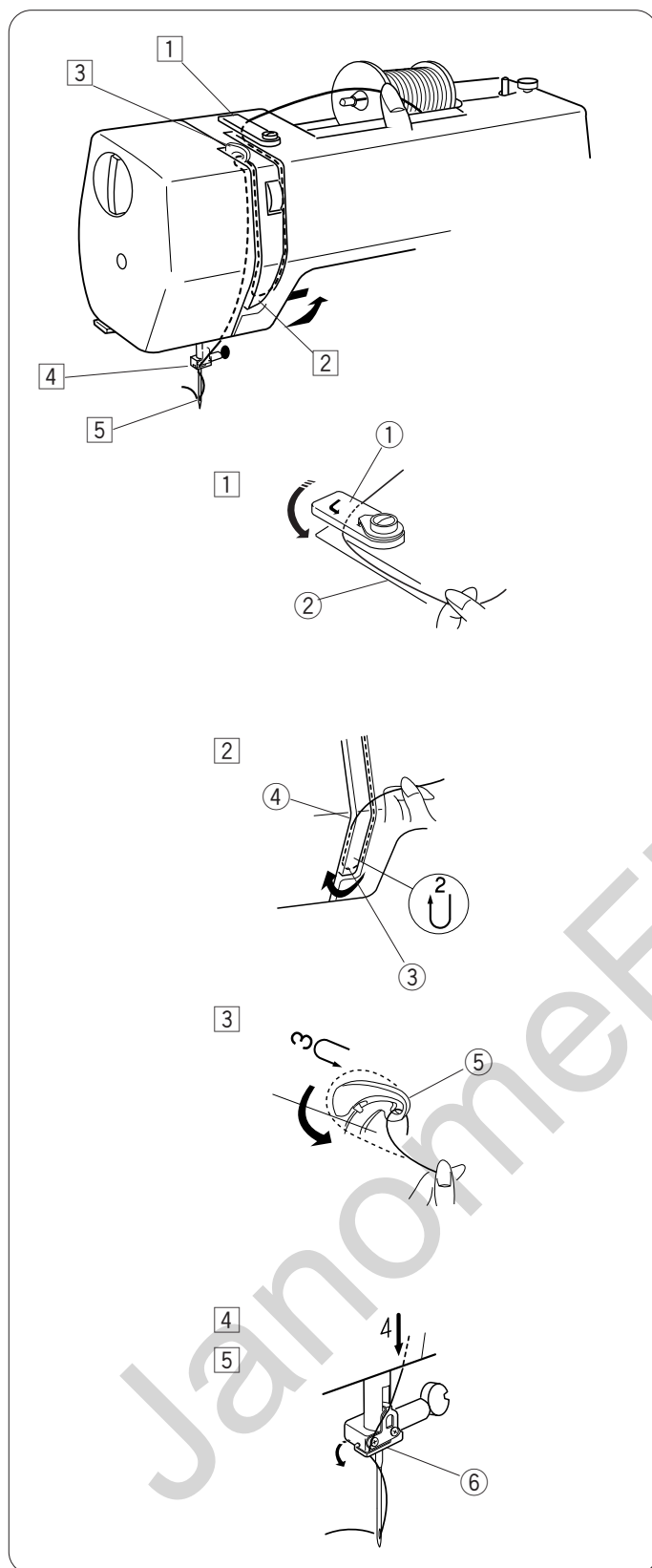

Threading the Machine

To set the needle thread:

Raise the thread take-up lever to the highest position by turning the handwheel.
Raise the presser foot.

- 1 Draw the thread from the spool and pass it under the thread guide. Then draw it down along the right channel.

- ① Thread guide
- ② Right channel

- 2 Draw the thread up around the bottom of the thread guide plate.

- Pull the thread up along the left channel
- ③ Thread guide plate
- ④ Left channel

- 3 Firmly draw the thread from right to left over the thread take-up lever and down into the take-up lever eye.

- ⑤ Thread take-up lever

- 4 Draw the thread down along the left channel and slip the thread behind the needle bar thread guide from the left.

- ⑥ Needle bar thread guide

- 5 Pass the thread through the needle eye from the front or use the needle threader (refer to the next page).

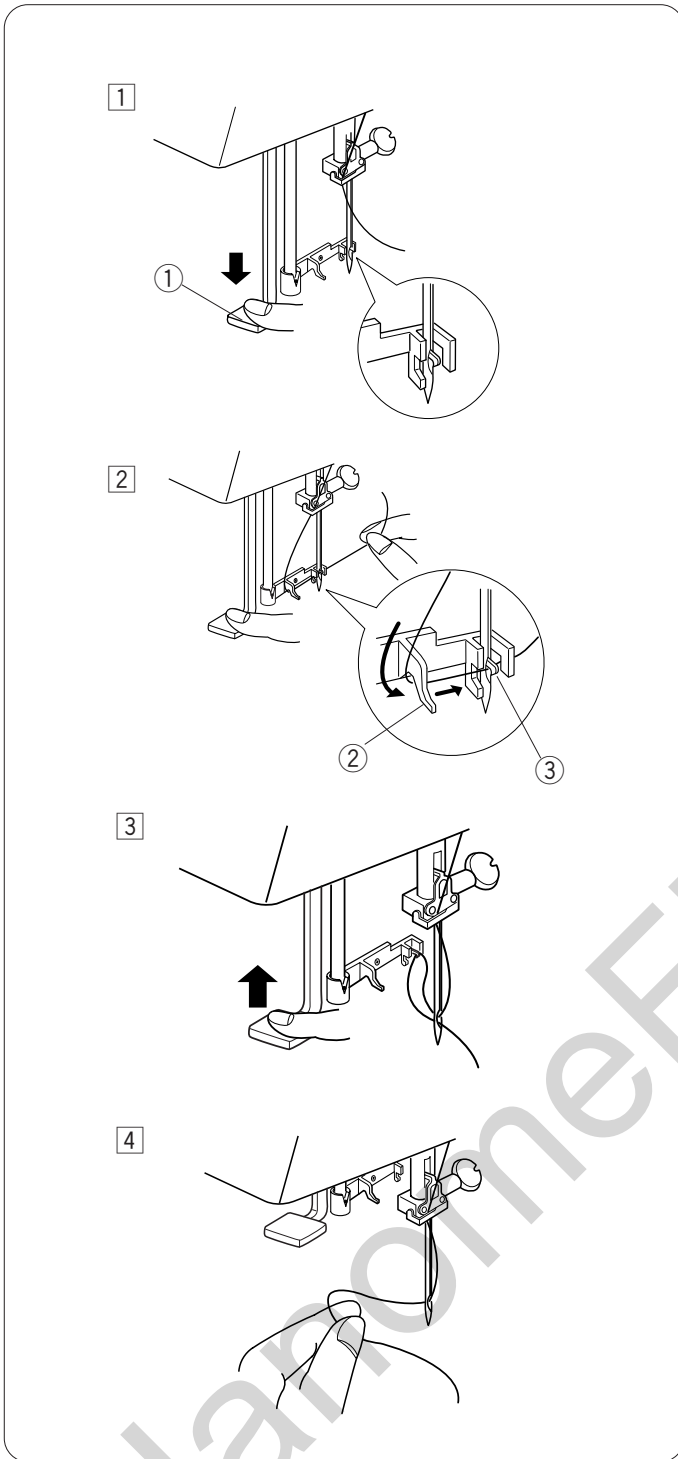

Needle threader

- 1 Raise the needle to its highest position and lower the presser foot. Push down the needle threader knob as far as it will go.
The hook comes out through the needle eye from behind.
① Threader knob

- 2 Draw the thread from the left around the guide and under the hook.
② Guide
③ Hook

- 3 Release the knob slowly while holding the thread end with your hand. A loop of the thread is pulled up through the needle eye.

- 4 Pull out the end of the thread through the needle eye.

Drawing up the Bobbin Thread

1

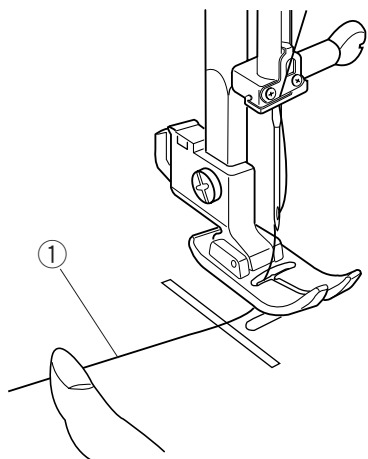

1 Raise the presser foot and hold the needle thread lightly with your left hand.

① Needle thread

2

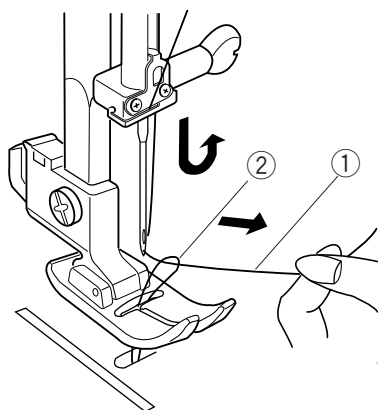

2 Turn the handwheel slowly toward you one complete turn. Bring the bobbin thread up by pulling the needle thread as illustrated.

① Needle thread

② Bobbin thread

3

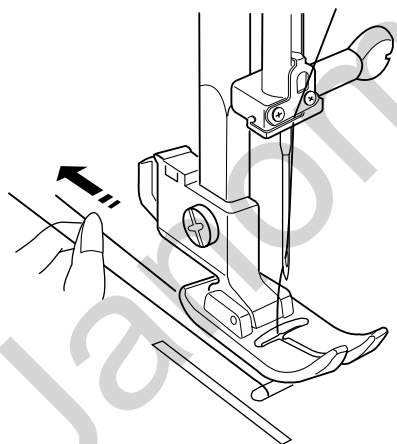

3 Pull 4" (10 cm) of both threads back and under the presser foot.

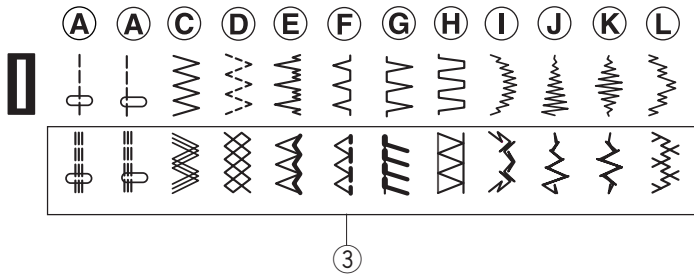

Selecting the Stitch Pattern

Raise the needle to its highest position.

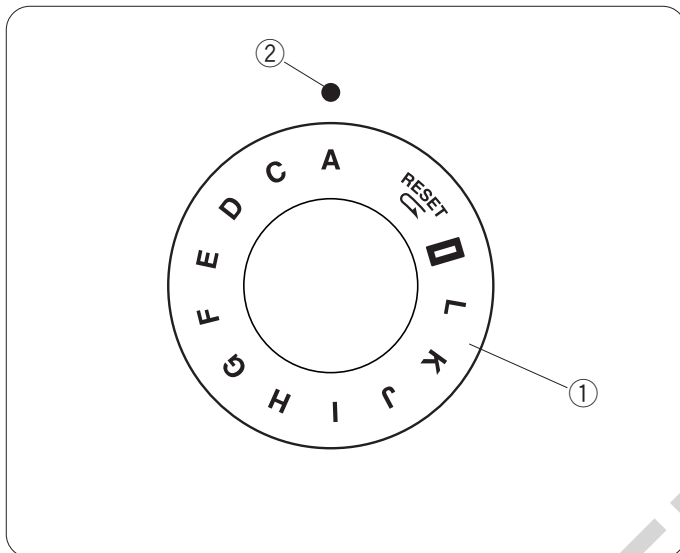

Pattern selector dial

Turn the pattern selector dial to set the symbol of the desired stitch pattern at the setting mark.

- ① Pattern selector dial
- ② Setting mark

CAUTION:
Do not turn the pattern selector dial while the needle is in the fabric, otherwise the needle may bend or break.

To select the stretch stitch patterns, set the stitch length dial at S.S.

- ③ Stretch stitch patterns

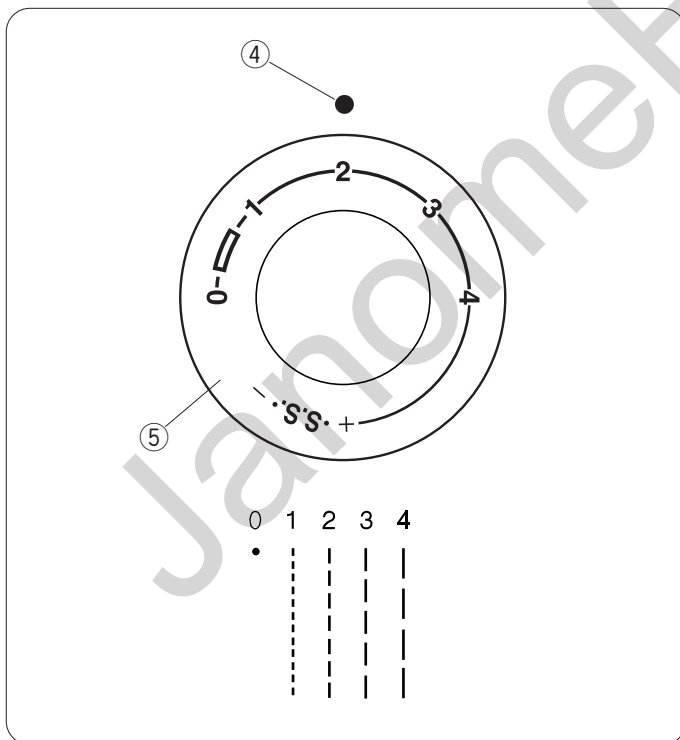

Stitch Length Dial

Turn the stitch length dial to set the desired stitch length number at the setting mark.

The higher the number, the longer the stitch

The "S.S." mark shows the adjustment range when sewing the buttonhole.

- ④ Setting mark
- ⑤ Stitch length dial

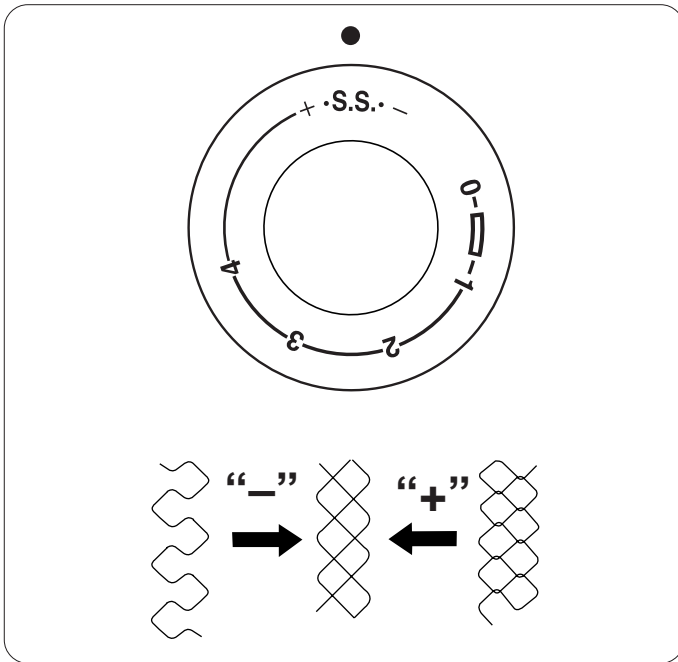

Adjusting stretch stitch balance

If the stretch stitch patterns are uneven when you sew on a particular fabric, correct them by turning the stitch length dial.

If the patterns are drawn out, correct them by setting the dial to the “-” side.

If the patterns are compressed, correct them by setting the dial to the “+” side.

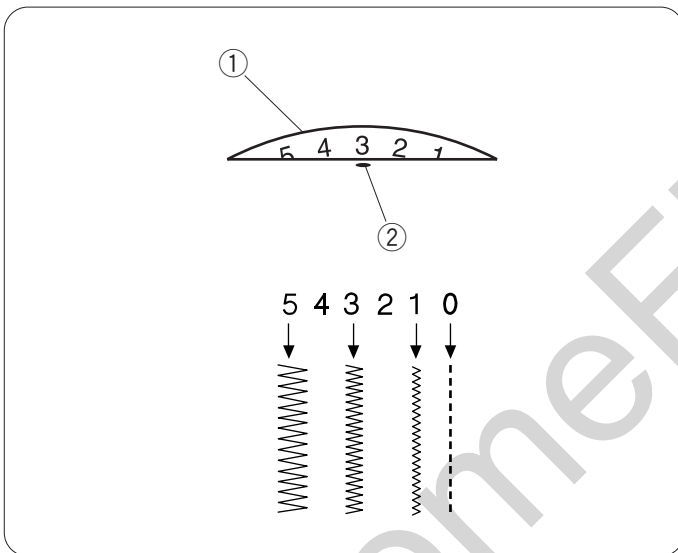

Stitch Width Dial

Turn the stitch width dial to set the desired stitch width number at the setting mark.

The higher the number, the wider the stitch

- ① Stitch width dial
- ② Setting mark



CAUTION:

Do not turn the stitch width dial while the needle is in the fabric, otherwise the needle may bend or break.

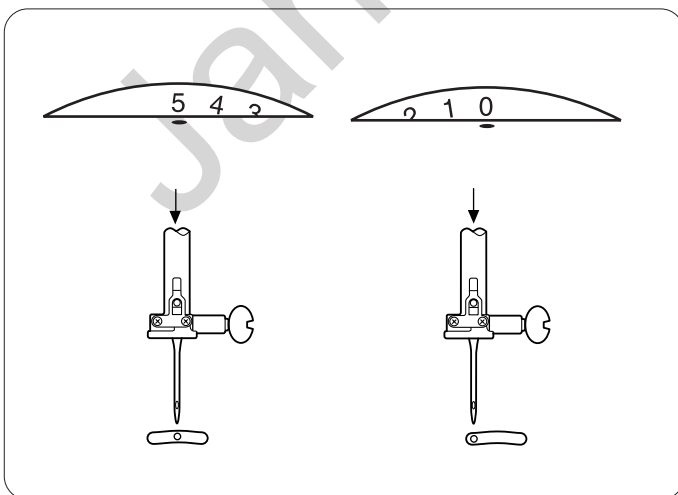

Variable needle position

The needle drop position of the straight stitches can be moved between the center (5) and left (0) with the stitch width dial.

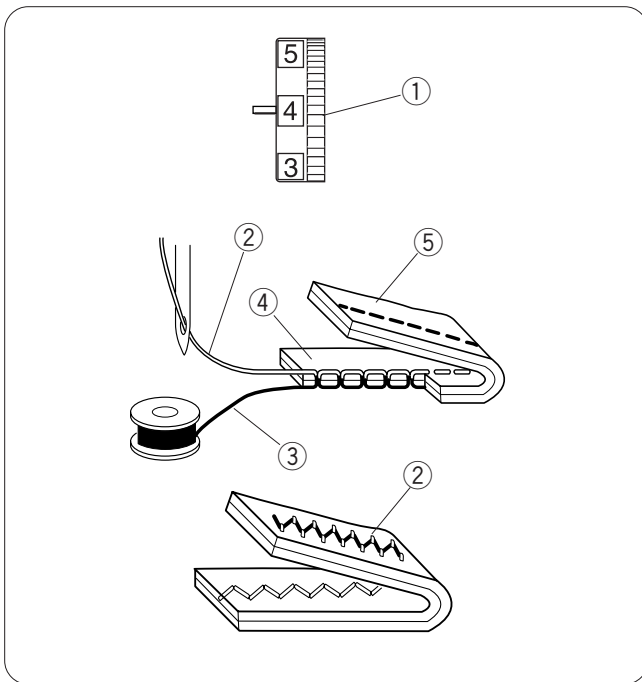

Balancing Needle Thread Tension

The thread tension should be adjusted depending on the sewing materials, layers of fabric and sewing method. To adjust the thread tension, turn the tension dial.

- ① Tension dial

Balanced tension:

The ideal straight stitch has threads locked between two layers of fabric, as illustrated.

For an ideal zigzag stitch, the bobbin thread does not show on the right side (top side) of the fabric, and the needle thread shows slightly on the wrong side (bottom side) of the fabric.

- ② Needle thread (Top thread)
- ③ Bobbin thread (Bottom thread)
- ④ Right side (Top side) of fabric
- ⑤ Wrong side (Bottom side) of fabric

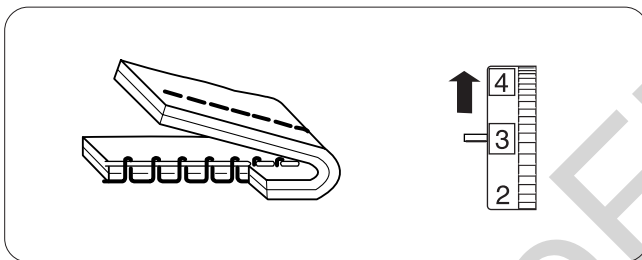

Needle thread tension is too tight:

The bobbin thread (bottom thread) will appear on the right side (top side) of the fabric. Loosen the needle thread tension by moving the dial to a lower number.

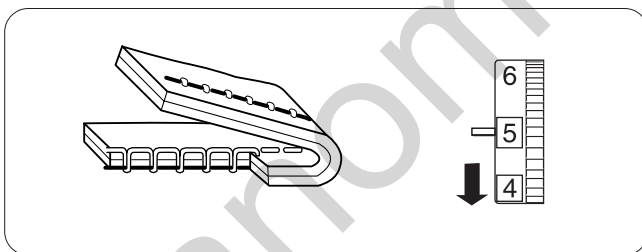

Needle thread tension is too loose:

The needle thread (top thread) will form loops on the wrong side (bottom side) of the fabric. Tighten the needle thread tension by moving the dial to a higher number.

SECTION 3. BASIC SEWING

Straight Stitch Sewing

Machine setting:

- ① Stitch pattern: A
- ② Stitch width: 0 or 5
- ③ Stitch length: 1.5 – 4
- ④ Thread tension: 2 – 6
- ⑤ Presser foot: Zigzag foot A

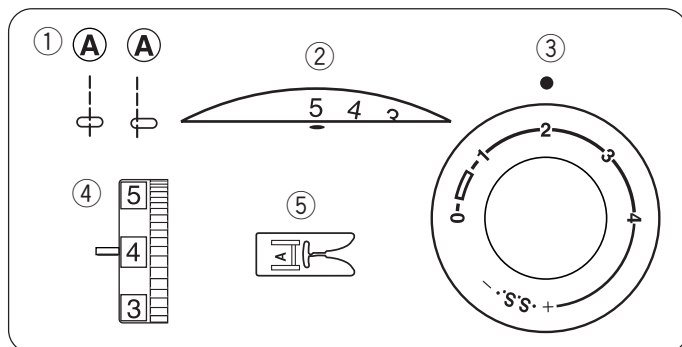

Starting to sew

Raise the presser foot and place the fabric under the foot.

Lower the needle into the fabric.

Lower the presser foot and smooth the threads toward the back. Depress the foot control.

NOTES:

Draw the threads to the left when sewing with the buttonhole foot.

To fasten the beginning of the seam, first sew several stitches in reverse then sew forward.

Changing the sewing direction

Stop the machine and turn the handwheel toward you to bring the needle down into the fabric.

Raise the presser foot.

Pivot the fabric around the needle to change sewing direction as desired. Lower the presser foot and continue sewing in the new direction.

Finishing sewing

Press the reverse stitch lever and sew several stitches in reverse at the end of the seam.

Raise the presser foot and remove the fabric, drawing the threads to the back.

Draw the threads up and into the thread cutter.

The threads are cut the proper length for starting the next seam.

- ① Thread cutter

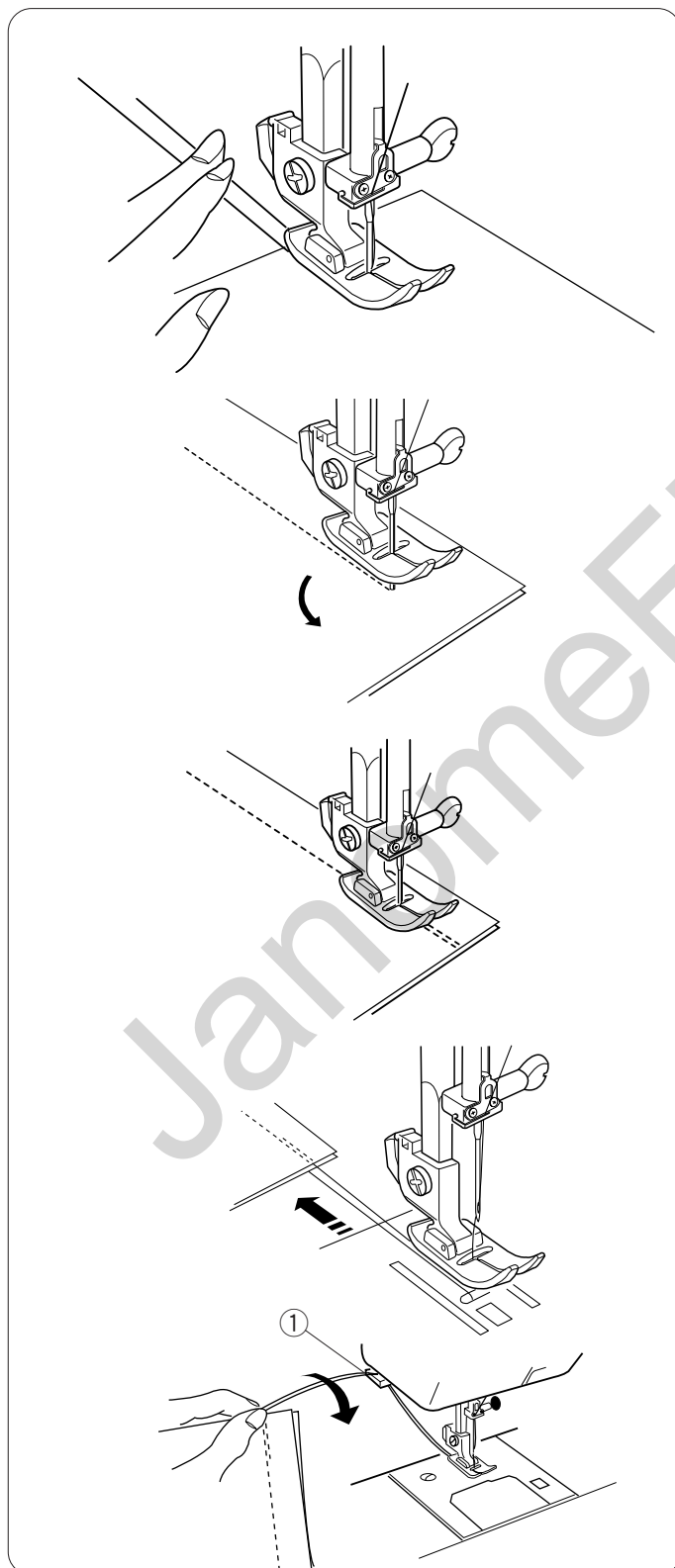

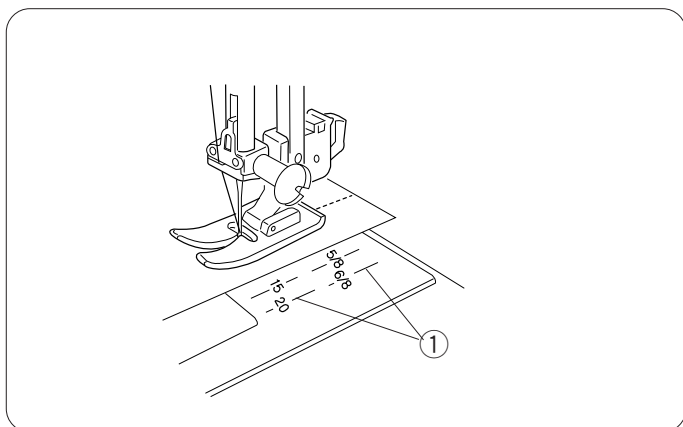

Seam guides on the needle plate

The seam guides on the needle plate help you to measure seam allowance.

The numbers indicate the distance between the center needle position and the seam guide.

① Seam guides

Number	15	20	4/8	5/8	6/8
Spacing (cm)	1.5	2.0	1.3	1.6	1.9
Spacing (inch)	(5/8)	(3/4)	1/2	5/8	3/4

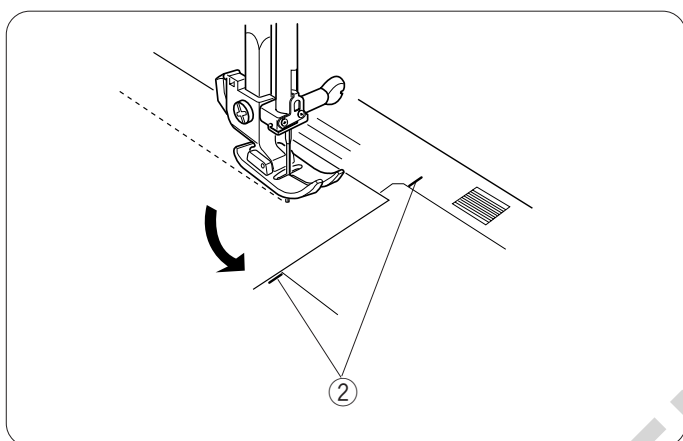

Turning a square corner

The cornering guide helps you maintain a 5/8" (1.6 cm) seam allowance when sewing a corner.

When the fabric edge facing you lines up with the cornering guide as illustrated, stop stitching and lower the needle into the fabric by turning the handwheel toward you.

Raise the presser foot and pivot the fabric so the edge of the fabric will align with the 5/8" (1.6 cm) seam guide.

Lower the presser foot and start stitching in the new direction.

② Cornering guide

SECTION 4. UTILITY STITCHES

Basic Zigzag

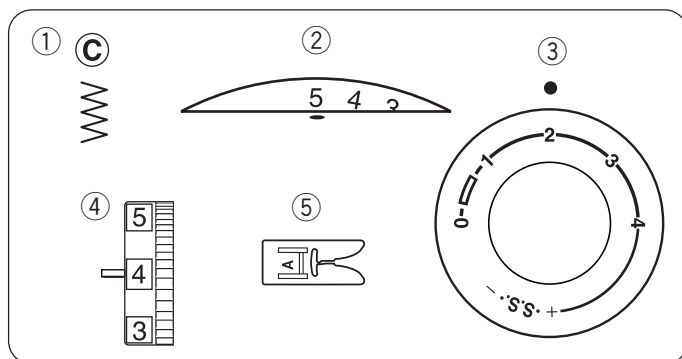

Machine setting

- ① Stitch pattern: C
- ② Stitch width: 1 – 5
- ③ Stitch length: 0.5 – 3
- ④ Thread tension: 2 – 5
- ⑤ Presser foot: Zigzag foot A

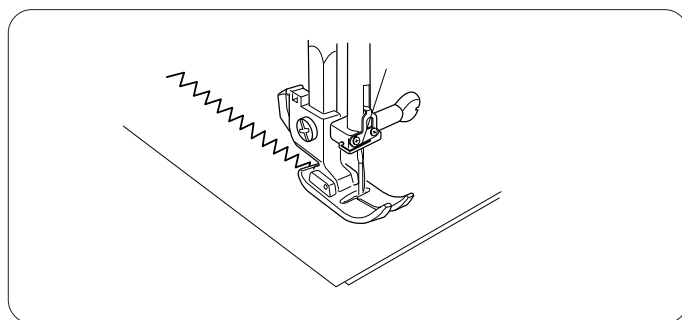

Simple zigzag stitching is widely used for overcasting, sewing on buttons etc.

Adjust the stitch length to suit your sewing needs.

NOTE:

Use a stabilizer for stretch fabrics such as tricot and knits to prevent puckering.

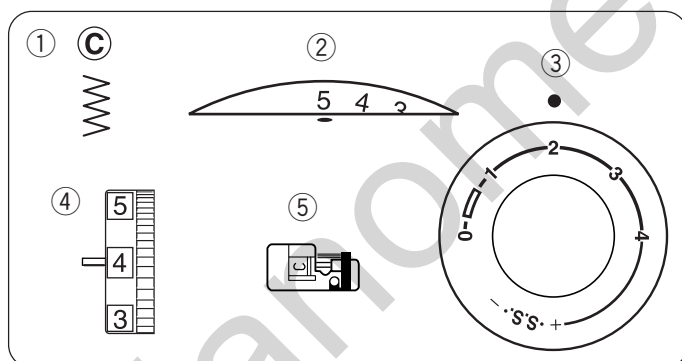

Overcasting

Machine setting

- ① Stitch pattern: C
- ② Stitch width: 5
- ③ Stitch length: 1 – 2
- ④ Thread tension: 3 – 7
- ⑤ Presser foot: Overedge foot C

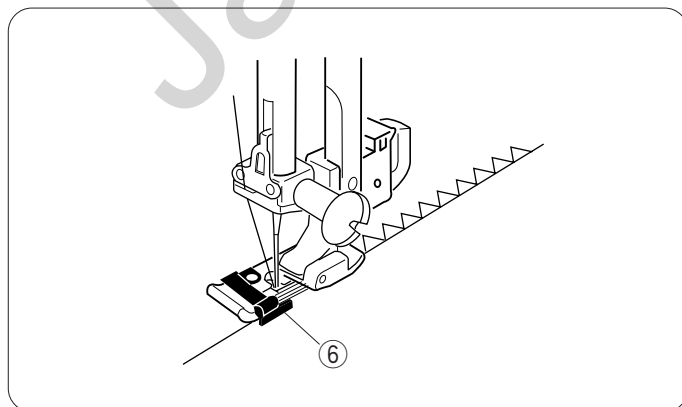

Overcasting is used to prevent fabrics from raveling at raw edges. It can be used to finish a hem edge. Place the edge of the fabric next to the guide of foot and sew while guiding the fabric edge along the guide.

⑥ Guide

CAUTION:

Do not set the stitch width less than 5 when using the overedge foot C, otherwise the needle may hit the foot causing the needle to bend or break.

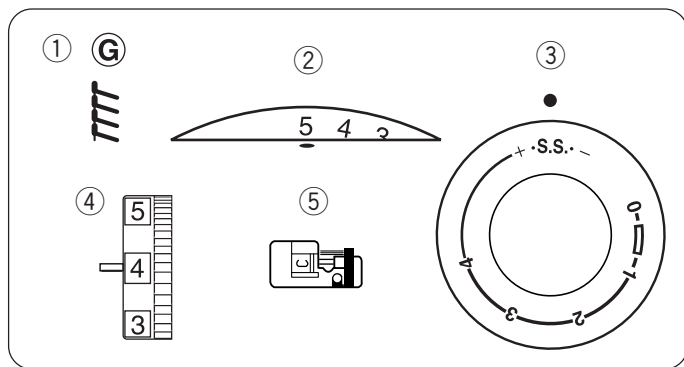

Knit Stitch

Machine setting

- ① Stitch pattern: G
- ② Stitch width: 5
- ③ Stitch length: S.S.
- ④ Thread tension: 3 – 7
- ⑤ Presser foot: Overedge foot C

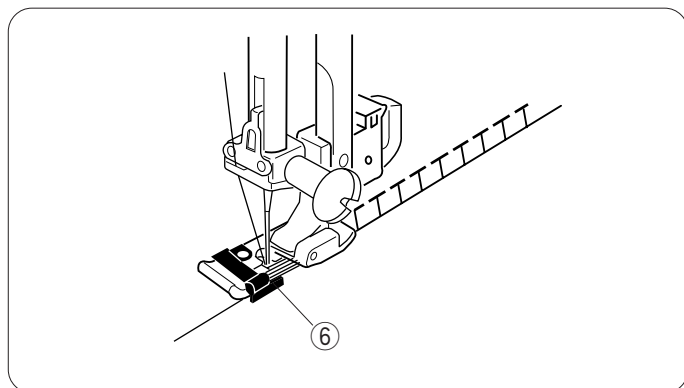

This stitch is ideal for finishing edges of stretch fabrics. It seals seams and finishes the fabric edges simultaneously. Place the edge of the fabric next to the guide of foot and sew while guiding the fabric edge along the guide.

- ⑥ Guide

⚠ CAUTION:
Do not set the stitch width less than 5 when using the overedge foot C, otherwise the needle may hit the foot causing the needle to bend or break.

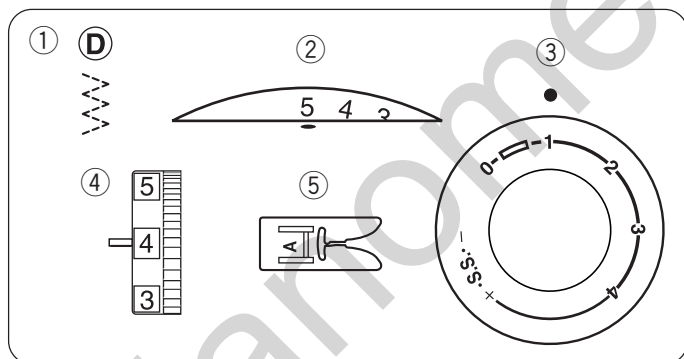

Tricot Stitch (Multiple Zigzag Stitch)

Machine setting

- ① Stitch pattern: D
- ② Stitch width: 3 – 5
- ③ Stitch length: 0.5 – 1.5
- ④ Thread tension: 3 – 6
- ⑤ Presser foot: Zigzag foot A

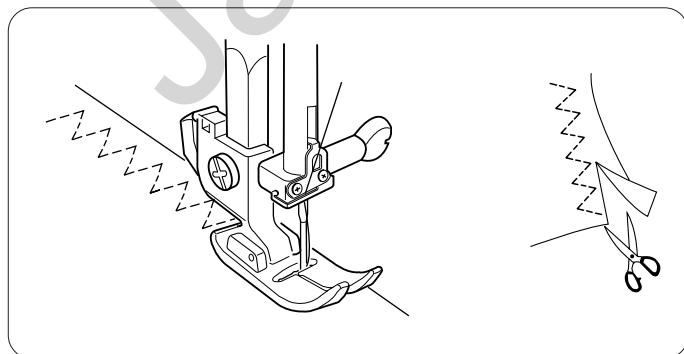

This stitch is used to finish a raw edge on synthetics and other fabrics that tend to pucker. Place the fabric to leave a 5/8" (1.6 cm) allowance. Trim the extra allowance after sewing. It is also used for mending tears.

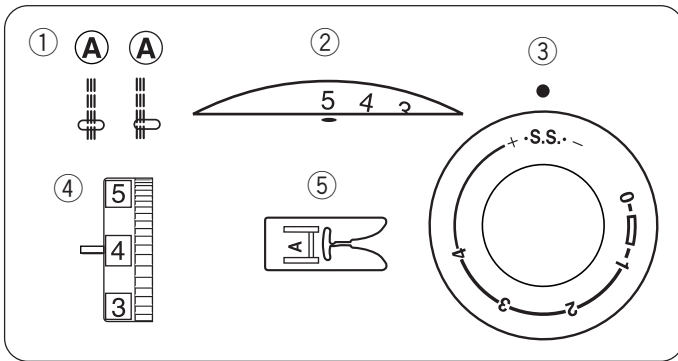

Straight Stretch Stitch

Machine setting

- ① Stitch pattern: A
- ② Stitch width: 0 or 5
- ③ Stitch length: S.S.
- ④ Thread tension: 2 – 5
- ⑤ Presser foot: Zigzag foot A

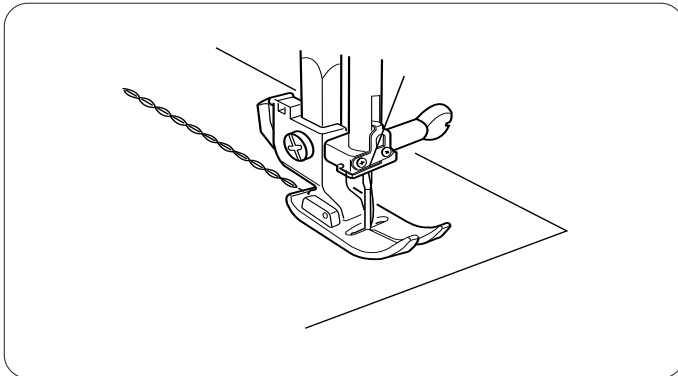

The pattern is sewn with two stitches forward and one stitch backward, forming a seam that does not rip easily. Use it to reinforce areas such as crotch and armhole seams.

Also use it when constructing items such as backpacks for extra strength.

Carefully guide the fabric while sewing as the fabric moves back and forth.

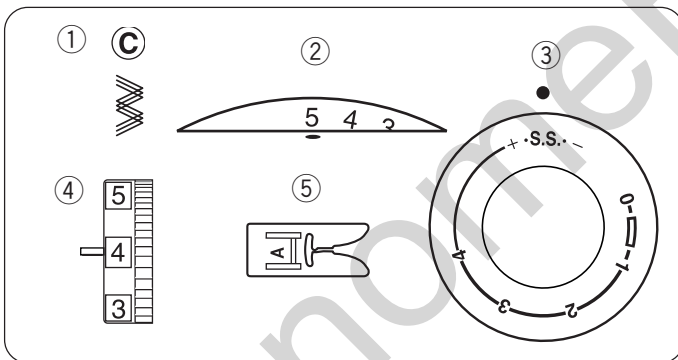

Zigzag Stretch Stitch

Machine setting

- ① Stitch pattern: C
- ② Stitch width: 2 – 5
- ③ Stitch length: S.S.
- ④ Thread tension: 2 – 5
- ⑤ Presser foot: Zigzag foot A

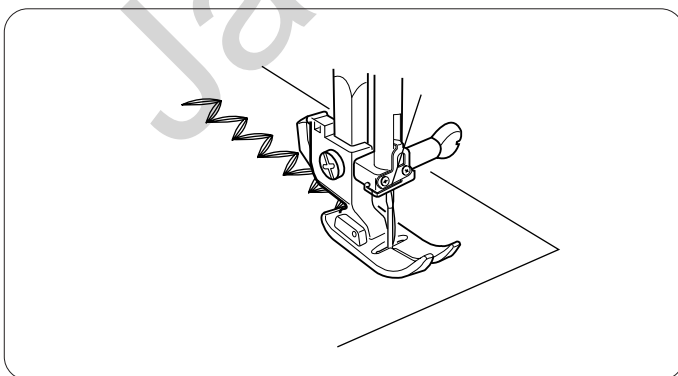

Sew on stretch fabrics in any area that you might use a zigzag stitch.

This stitch is used as a decorative topstitch as well.

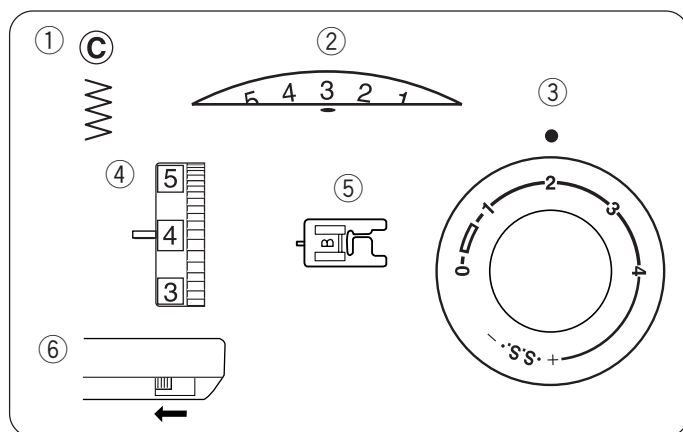

Button Sewing

Machine setting

- ① Stitch pattern: C
- ② Stitch width: Adjust as necessary
- ③ Stitch length: Any
- ④ Thread tension: 3 – 7
- ⑤ Presser foot: Buttonhole foot B
- ⑥ Feed dog: Lowered

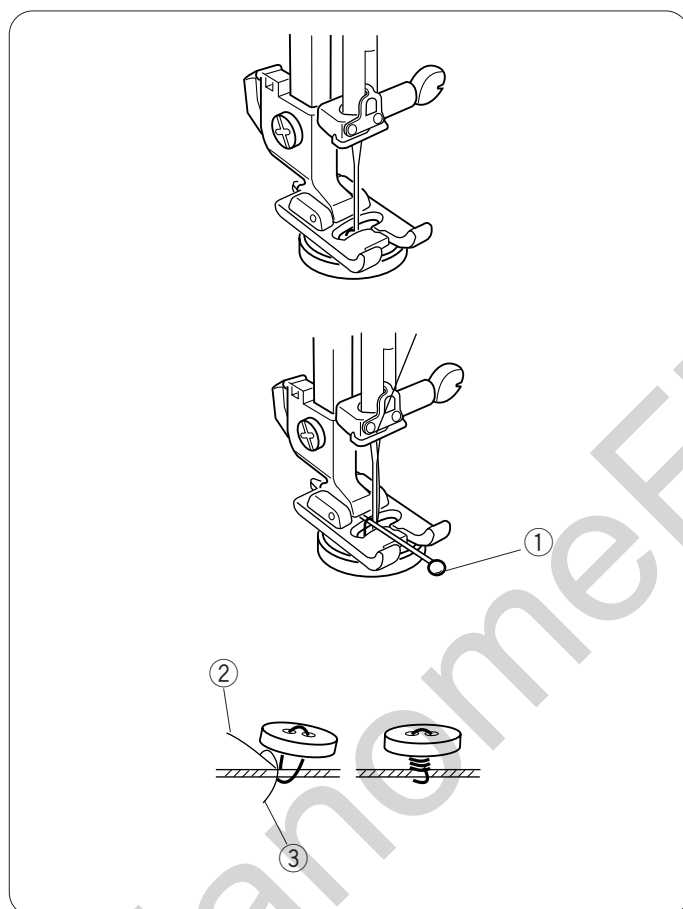

Unthread the needle. Adjust the stitch width to match it with the span of the holes in the button. Turn the handwheel to check if the needle enters into each hole in the button.

Lower the foot to hold the button in place.

The holes in the button should align with the slot of the foot.

A pin can be placed on the foot to form a shank.

Make sure to check if the needle enters into both holes in the button.

① Pin

Re-thread the needle and sew about 10 stitches and cut the needle and bobbin threads at the beginning.

Raise the presser foot and remove the fabric. Cut the needle and bobbin threads leaving 8" (20 cm) tails.

Bring the needle thread between the button and fabric through the holes in the button.

Pull the needle thread to pick bobbin thread up to the right side of the fabric.

Wind the threads to form a shank and tie them together.

- ② Needle thread
- ③ Bobbin thread

NOTE:

Raise the feed dog after sewing.

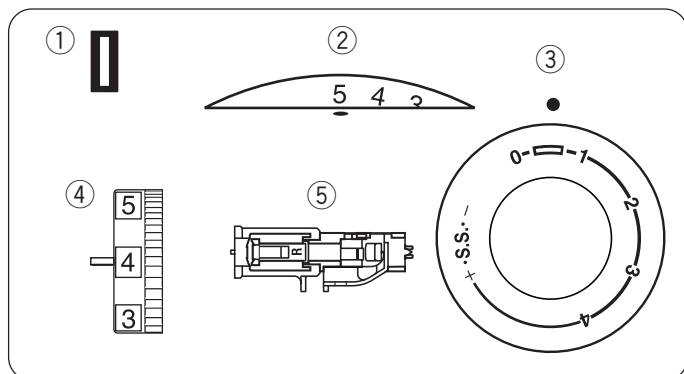

Automatic Buttonhole

Machine setting

- ① Stitch pattern: BH
- ② Stitch width: 4 – 5
- ③ Stitch length: 0.5 – 1
- ④ Thread tension: 1 – 5
- ⑤ Presser foot: Automatic buttonhole foot R

NOTES:

The size of buttonhole is automatically determined by placing the button in the automatic buttonhole foot. The button holder of the foot takes a button size up to 1" (2.5 cm) in diameter. Make a test buttonhole on a sample duplicating the fabric, interfacing and seams of the actual garment to check the settings. Use interfacing on stretch fabrics.

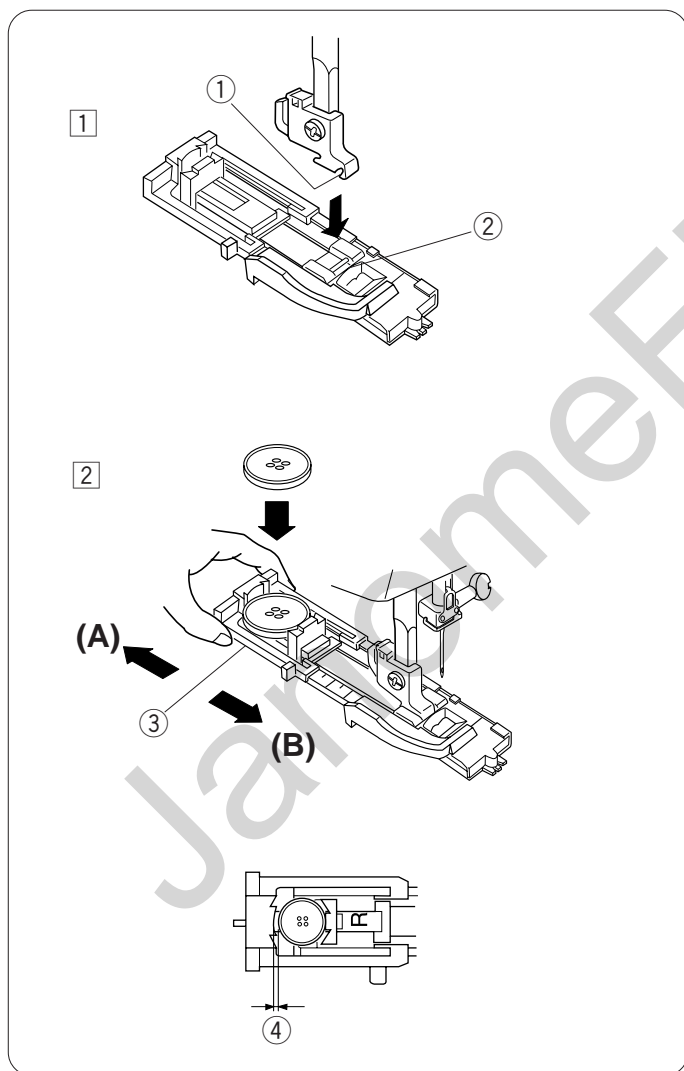

Turn the handwheel toward you to raise the needle to its highest position.

- ① Place the automatic buttonhole foot with the pin lies just under the groove on the foot holder. Lower the foot lifter to snap the foot in place.
 - ① Groove
 - ② Pin
- ② Pull to open the button holder to the back (A), and place the button in it. Push back (B) the button holder against the button to hold it tight.
 - ③ Button holder

NOTE:

For thick buttons, make a test buttonhole. If the button does not fit through the test buttonhole, lengthen the buttonhole by pulling the button holder a little to the back.

- ④ Pull a little

3

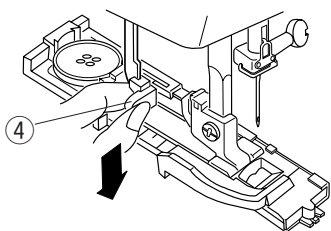

4

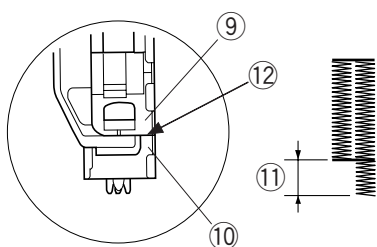
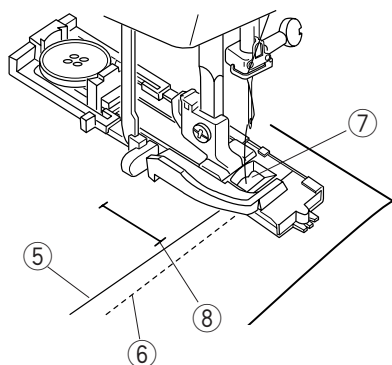

5

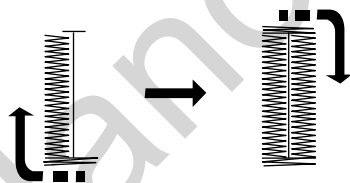

6

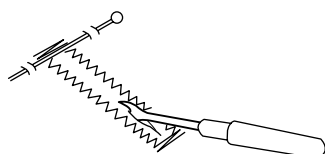

3 Pull the buttonhole lever down as far as it will go.

4 Buttonhole lever

4 Raise the foot and pass the needle thread through the opening in the foot. Draw both needle and bobbin threads to the left.

Insert the fabric under the foot and lower the needle into the fabric at the starting point.

Lower the foot.

5 Needle thread

6 Bobbin thread

7 Opening

8 Starting point

NOTE:

Make sure there is no gap between the slider and front stopper. If there is a gap, the length of the right and left rows of the buttonhole will differ.

9 Slider

10 Front stopper

11 Difference

12 There should be no gap.

5 Sew slowly and stop the machine when a buttonhole is completed.

The machine sews the front bartack and left row first, then the back bartack and right row.

6 Raise the foot and remove the fabric.

Cut both needle and bobbin threads leaving about 4" (10 cm) thread ends.

Draw the needle thread to wrong side of fabric by pulling the bobbin thread.

Then, knot the threads.

Insert a pin inside the bartack. Then cut the opening with seam ripper.

Take care not to cut the stitches.

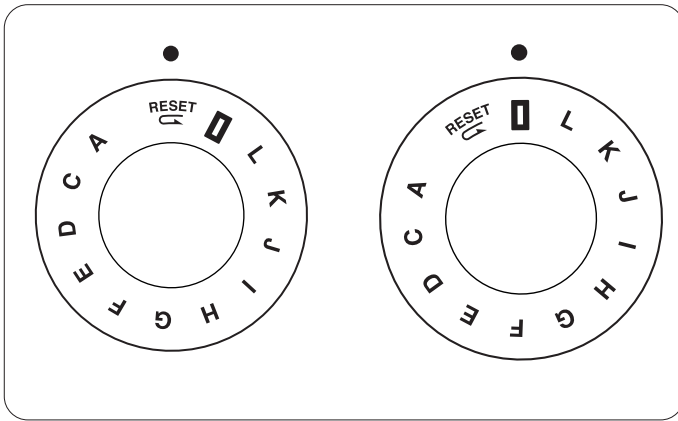

To sew another buttonhole, turn the stitch selector to “RESET”, then back to “” again, as shown.

Now, simply step on the foot control to sew an identical buttonhole.

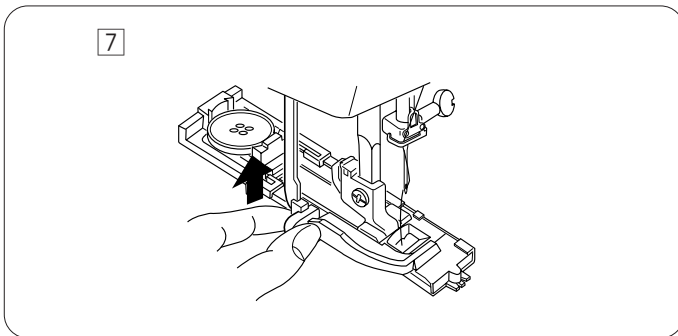

7 When buttonhole sewing is finished, push the buttonhole lever up as far as it will go.

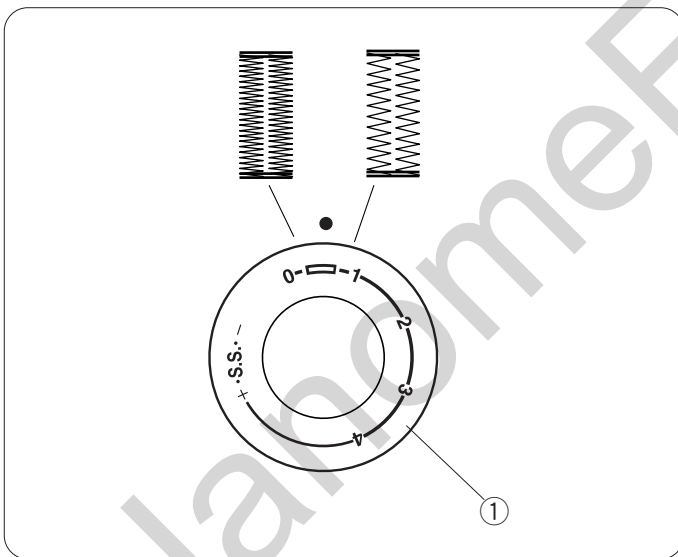

Adjusting the buttonhole stitch density

Turn the stitch length dial within the range of “” to adjust the buttonhole stitch density.

- ① Stitch length dial

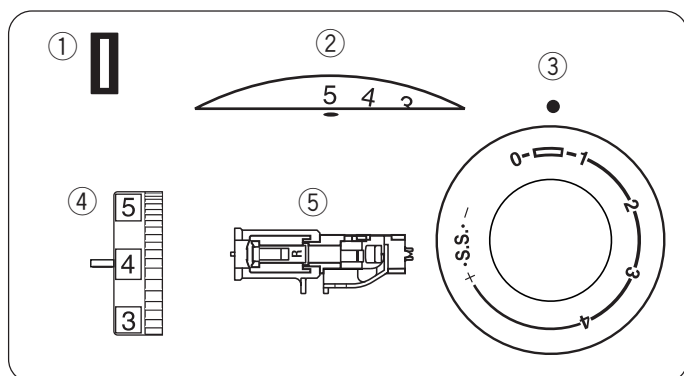

Corded Buttonhole

Machine setting

- ① Stitch pattern: BH
- ② Stitch width: 4 – 5
- ③ Stitch length: 0.5 – 1
- ④ Thread tension: 1 – 5
- ⑤ Presser foot: Automatic buttonhole foot R

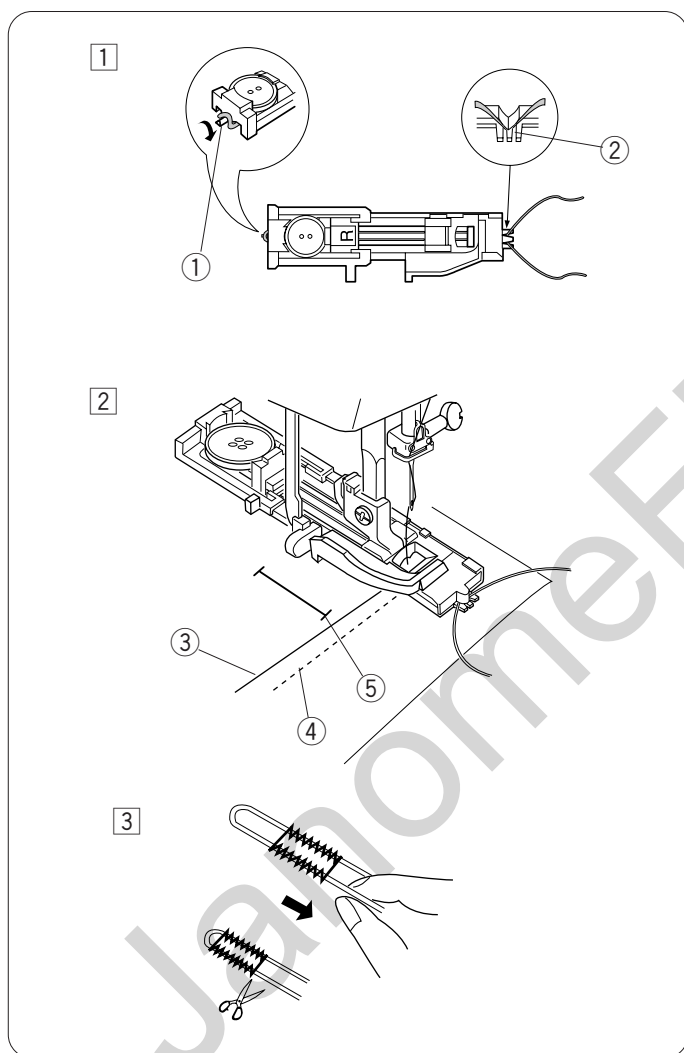

- ① With the buttonhole foot raised, hook the filler cord on the spur at the back of the foot. Bring the ends toward you under the foot, clearing the front end. Hook the filler cord into the forks on the front of the foot to hold them tight.
 - ① Spur
 - ② Forks
- ② Draw both needle and bobbin thread to the left. Lower the needle into the fabric at the starting point and lower the foot. Depress the foot control gently and sew the buttonhole over the cord. The sewing sequence is the same as the automatic buttonhole.
 - ③ Needle thread
 - ④ Bobbin thread
 - ⑤ Starting point
- ③ Pull the left end of the filler cord to tighten it and cut the excess tails. To cut the buttonhole opening, refer to the instructions on page 25.

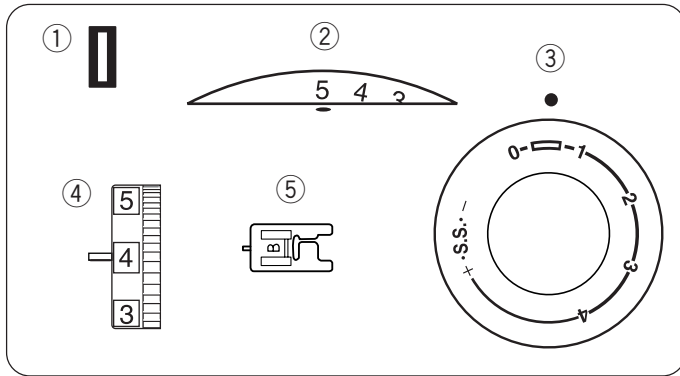

Manual Buttonhole

Machine setting

- ① Stitch pattern: BH
- ② Stitch width: 4 – 5
- ③ Stitch length: 0.5 – 1
- ④ Thread tension: 1 – 5
- ⑤ Presser foot: Buttonhole foot B

If the diameter of the button is more than 1" (2.5 cm), a buttonhole must be made manually as follows:

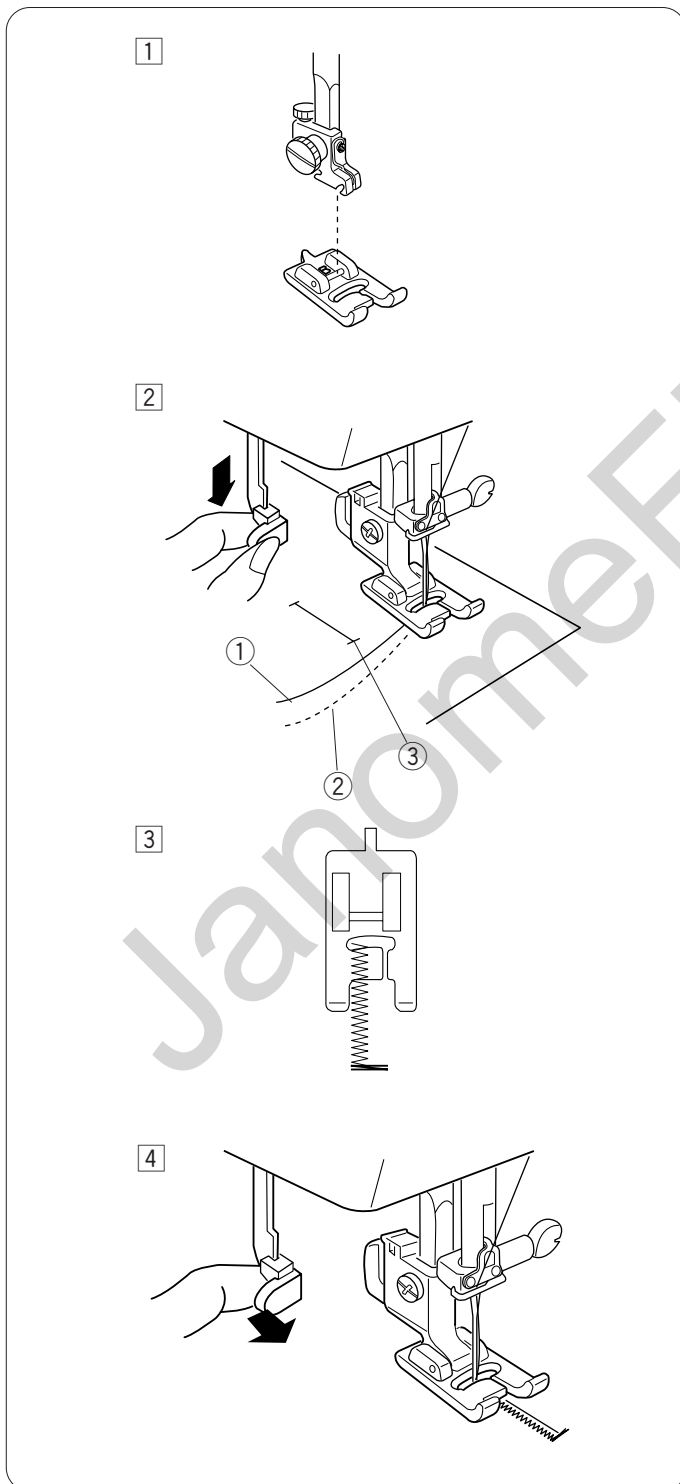

- ① Replace the foot with the buttonhole foot B.

- ② Pull the buttonhole lever down as far as it will go. Draw both needle and bobbin thread to the left. Lower the needle into the fabric at the starting point, and lower the foot.
 - ① Needle thread
 - ② Bobbin thread
 - ③ Starting point

- ③ Sew the front bartack and left row to the desired length then stop the machine.

- ④ Click the buttonhole lever toward you.

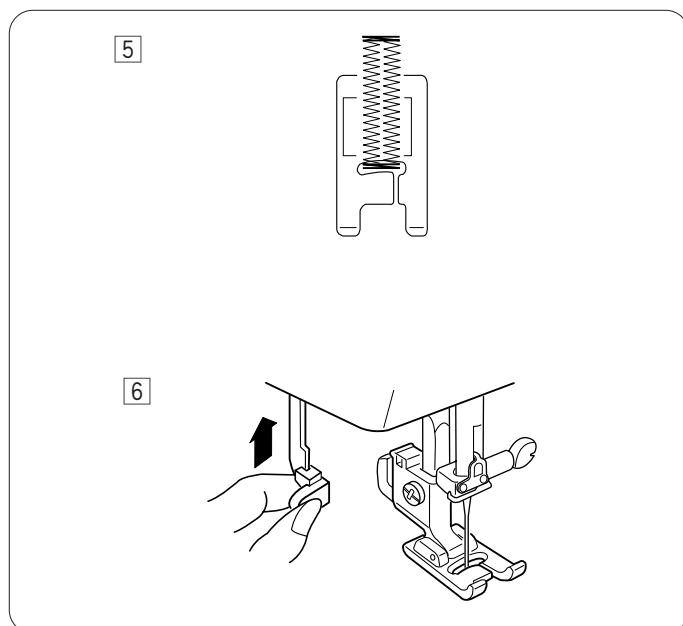

5 Restart the machine to sew the back bartack and right row, and then stop the machine at the starting point.

6 When buttonhole sewing is finished, push the buttonhole lever up as far as it will go.

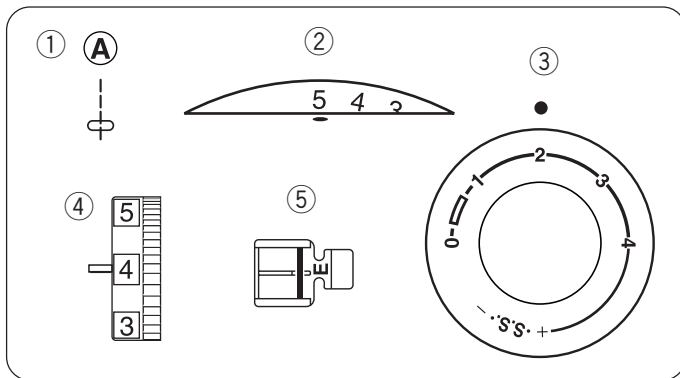

Zipper Application

Machine setting

- ① Stitch pattern: A
- ② Stitch width: 5
- ③ Stitch length: 1.5 – 4
- ④ Thread tension: 3 – 6
- ⑤ Presser foot: Zipper foot E

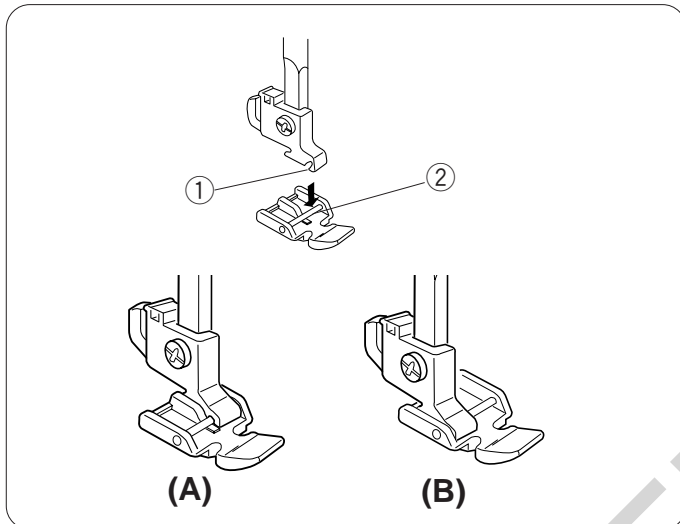

Attaching the zipper foot

A: To sew the left side of the zipper, attach zipper foot with the right side pin.

B: To sew the right side of zipper, attach the zipper foot with the left side pin.

- ① Groove
- ② Pin

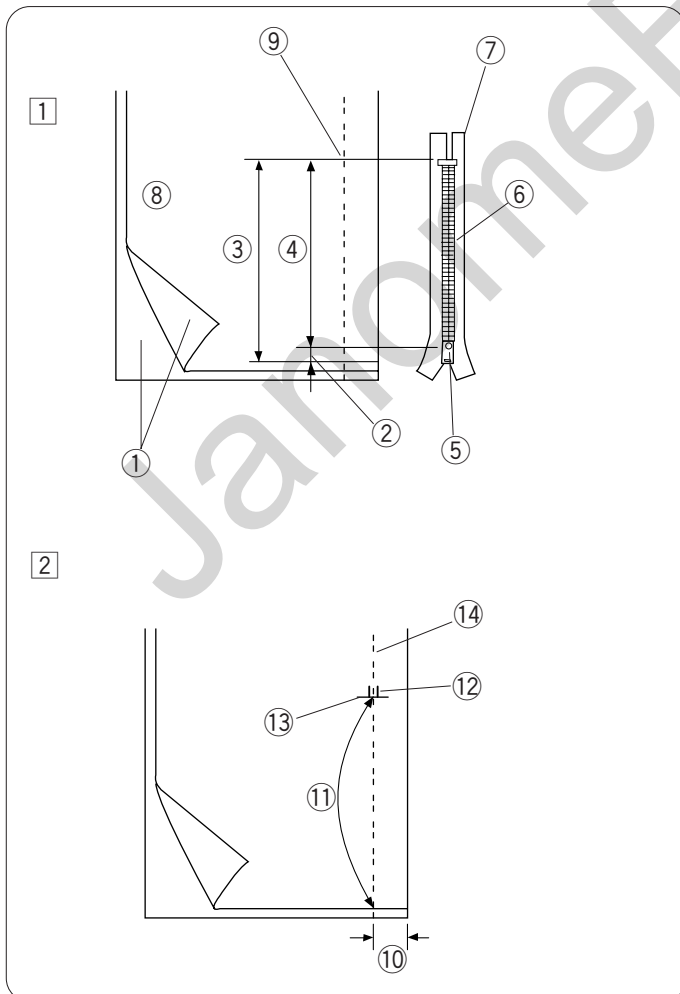

Fabric preparation

① Add 3/8" (1 cm) to the zipper size. This is the overall opening size.

- ① Right side of the fabric
- ② 3/8" (1 cm)
- ③ Opening size
- ④ Zipper size
- ⑤ Slider
- ⑥ Zipper teeth
- ⑦ Zipper tape
- ⑧ Wrong side of the fabric
- ⑨ End of the opening

② Place the right (top) sides of the fabric together. Sew a bottom seam 5/8" (2 cm) from the right edge to the zipper bottom stop position. Sew a few stitches in reverse to lock.

Increase the stitch length to "4", set needle thread tension to "1", and baste the entire length of the fabric.

- ⑩ 5/8" (2 cm)
- ⑪ Basting
- ⑫ Reverse stitch
- ⑬ End of the opening
- ⑭ Bottom seam

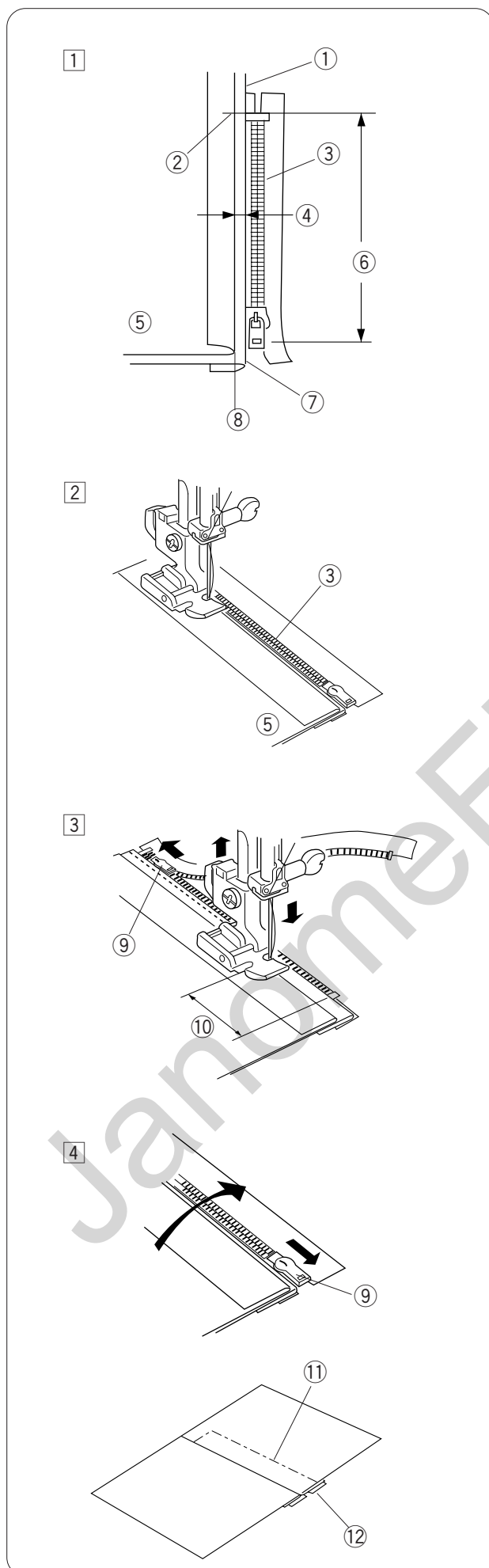

To sew

- 1 Attach zipper foot with the right side pin. Fold back the upper layer seam allowance. Fold back the lower layer seam allowance to leave a 1/8" (0.4 cm) margin of fabric.
 - 1 Lower layer
 - 2 End of the opening
 - 3 Zipper teeth
 - 4 1/8" (0.4 cm) margin
 - 5 Upper layer
 - 6 Opening size
 - 7 Folded edge
 - 8 Basting

- 2 Place zipper teeth next to margin edge and baste the zipper tape to the lower fabric layer. Align zipper foot with margin edge. Return thread tension and stitch length to original settings. Sew a seam the entire length of zipper tape.

- 3 Stop the machine 2" (5 cm) before reaching the slider, with needle in the fabric and raise the foot, then unzip a few inches to clear a path for stitching.
 - 9 Slider
 - 10 2" (5 cm)

- 4 Remove fabric and close zipper. Take the upper fabric layer and lay it flat over the zipper. Baste the zipper tape to the upper fabric layer.
 - 11 Basting
 - 12 Zipper tape

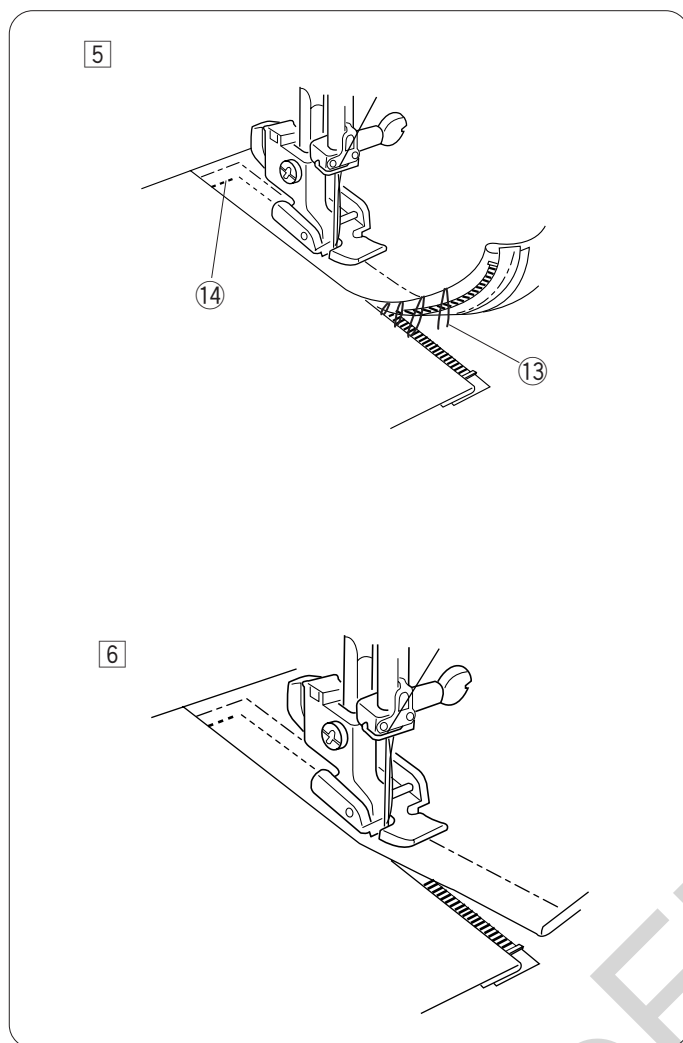

- 5 Raise and release the foot, and re-attach it with the left side pin.
Starting just below zipper bottom stop, sew across fabric to about 3/8" (1 cm) distance from the basting line.
Turn fabric 90 degrees and sew a seam the entire length of the zipper tape. Before reaching the slider, stop the machine with needle in fabric and raise the foot. Use seam ripper to open a few inches of basting stitch.
- 13 Unstitch basting
 - 14 3/8" (1 cm)

- 6 Unzip a few inches to clear a path for stitching.
At end of seam, sew a few stitches in reverse to lock.
Once both sides of zipper are sewn, use the seam ripper to open the basting stitch.

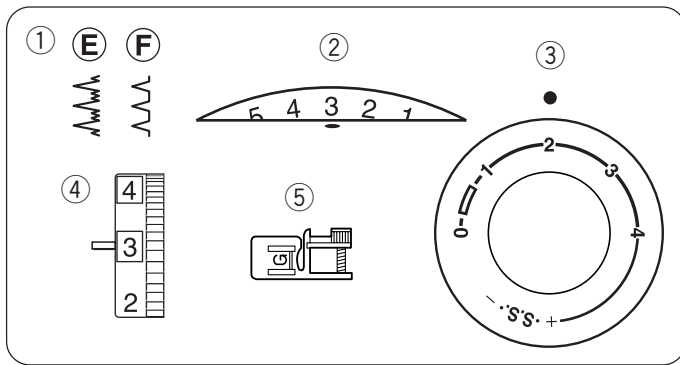

Blind Hemming

Machine setting

- ① Stitch pattern: E or F
- ② Stitch width: 2 – 3
- ③ Stitch length: 2 – 3
- ④ Thread tension: 1 – 4
- ⑤ Presser foot: Blind hemming foot G

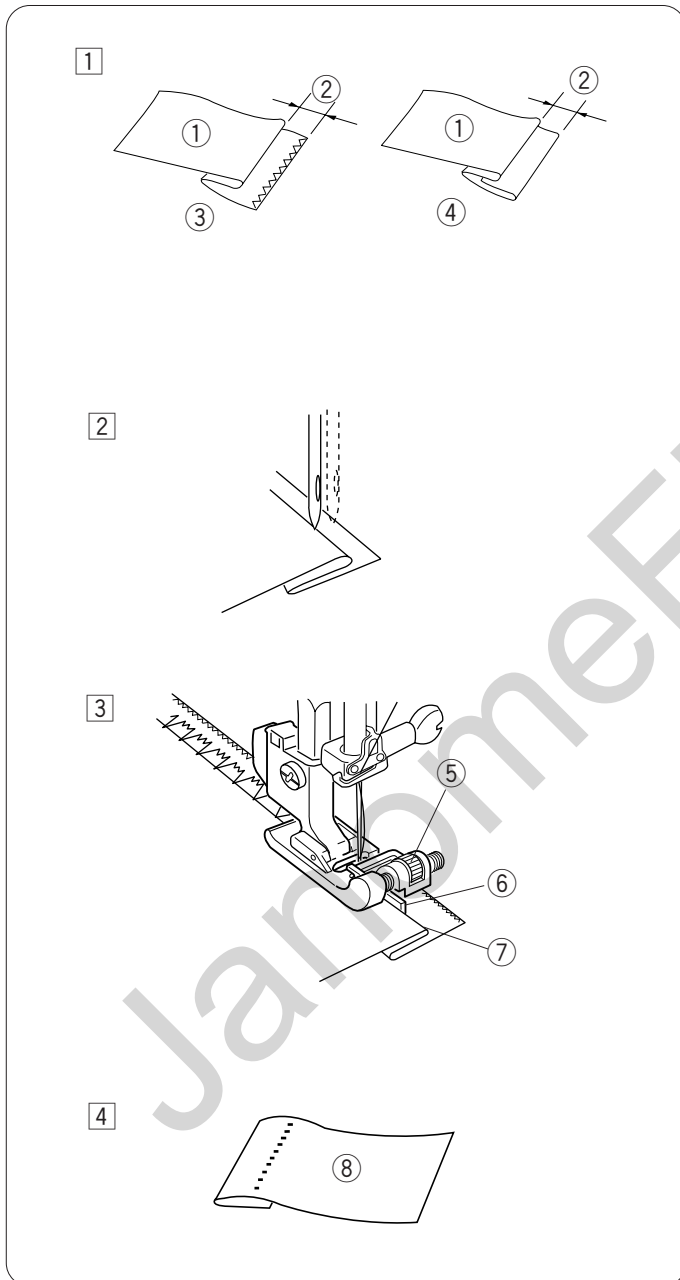

- ① On heavy weight fabrics that ravel, the raw edge should be overcast first.
Fold the hem under the fabric as illustrated for fine or medium fabrics.
Fold a hem with the wrong side up forming a 1/8" (0.5 cm) allowance.
 - ① Wrong side of the fabric
 - ② 1/8" (0.5 cm)
 - ③ Heavy weight fabric
 - ④ Fine and medium weight fabric
- ② Place the fabric so that the needle just pierces the folded edge when the needle comes over the extreme left side.
Lower the presser foot.
- ③ Turn the screw to align the guide on the foot with the folded edge so that the needle just pierces the fold.
If the needle pierces too far left, move the guide slightly to the left.
If the needle misses the fold, move the guide slightly to the right.
Sew slowly while guiding the folded edge along the guide.
 - ⑤ Screw
 - ⑥ Guide
 - ⑦ Folded edge
- ④ Open and press the fabric after sewing is finished.
 - ⑧ Right side of the fabric

NOTE:

If the needle drops too far left, the stitches will be apparent on the right side of the fabric.

SECTION 5. DECORATIVE STITCHES

Decorative Satin Stitches

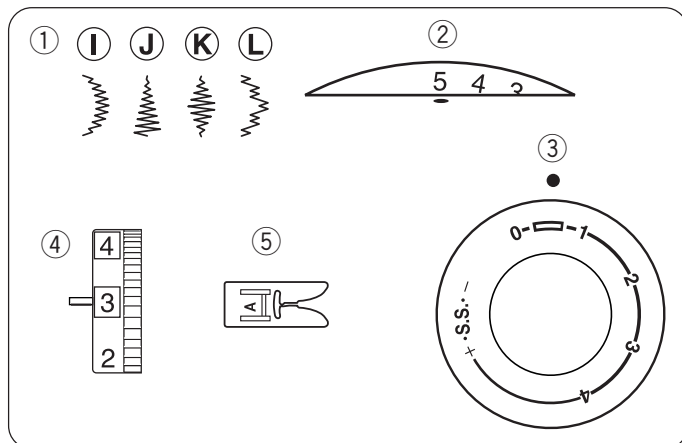

Machine setting

- ① Stitch pattern: I – L
- ② Stitch width: 3 – 5
- ③ Stitch length: 0.5 – 1
- ④ Thread tension: 1 – 4
- ⑤ Presser foot: Zigzag foot A or Buttonhole foot B

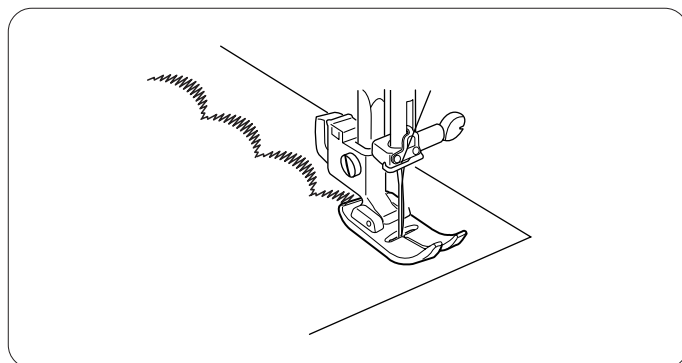

Determine the appropriate stitch density by test sewing. For a delicate appearance on fabric such as chiffon, use a single layer with a tear-away backing, if necessary. Reduce the needle thread tension slightly to achieve the better result.

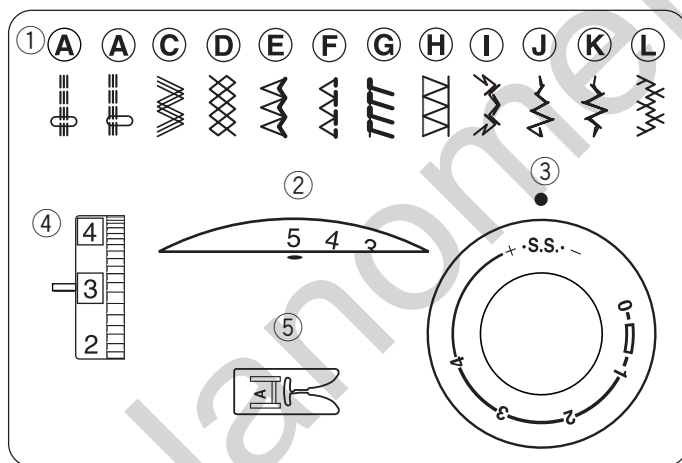

Decorative Stretch Stitches

Machine setting

- ① Stitch pattern: A – L
- ② Stitch width: 3 – 5
- ③ Stitch length: S.S.
- ④ Thread tension: 1 – 4
- ⑤ Presser foot: Zigzag foot A

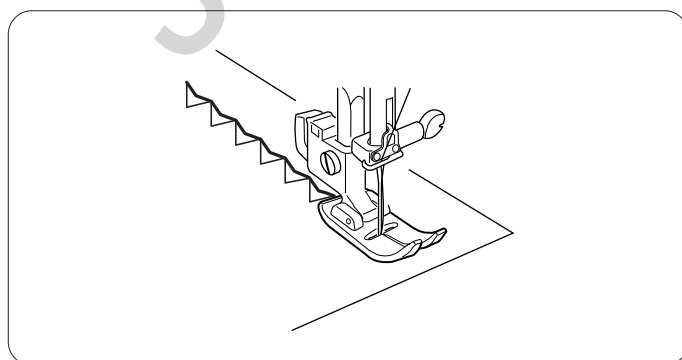

Decorative stretch patterns are used for adding a creative and personalized touch to items. Carefully guide the fabric while sewing as the fabric moves back and forth.

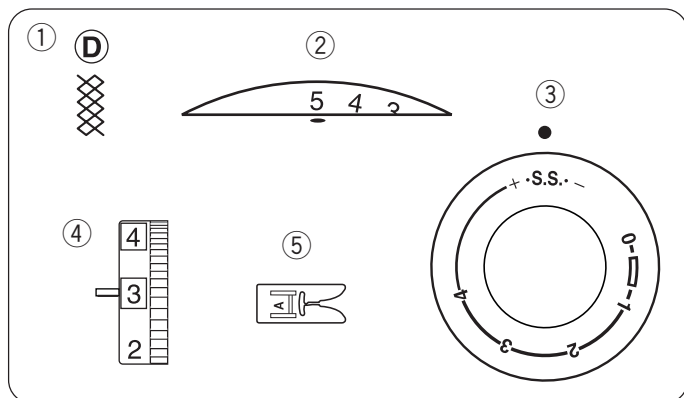

Smocking

Machine setting

- ① Stitch pattern: D
- ② Stitch width: 3 – 5
- ③ Stitch length: S.S.
- ④ Thread tension: 1 – 4
- ⑤ Presser foot: Zigzag foot A

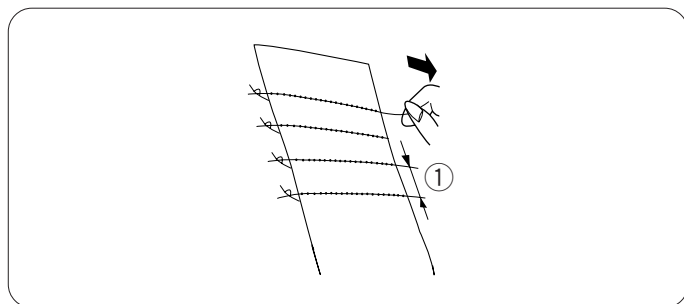

Step 1:

Choose a soft and lightweight fabric such as batiste, gingham or challis. Cut the fabric three times wider than the project width.

Increase the stitch length to “4” and loosen thread tension to “1”. Sew rows of straight stitches 3/8” (1 cm) apart across the area to be smocked.

- ① 3/8” (1 cm)

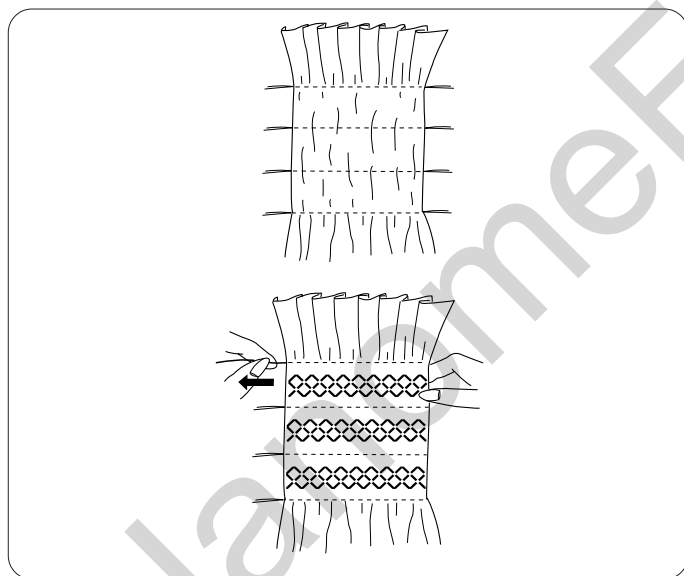

Step 2:

Knot the threads along one end. From the other end, pull the bobbin threads to distribute gathers evenly and secure the threads.

Return the thread tension to the original setting.

Sew rows of the smocking stitch between the gathering stitches.

Remove the gathering stitches after finished.

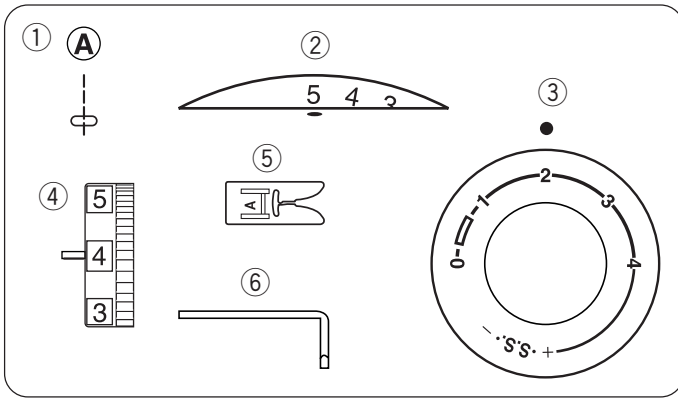

Quilting

Machine setting

- ① Stitch pattern: A
- ② Stitch width: 0 or 5
- ③ Stitch length: 1.5 – 4
- ④ Thread tension: 3 – 6
- ⑤ Presser foot: Zigzag foot A
- ⑥ Quilting guide

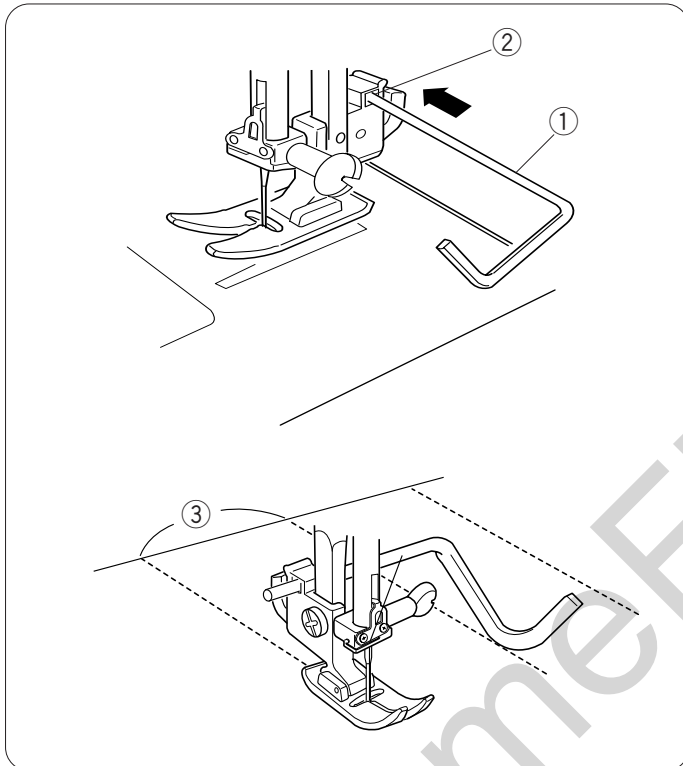

The quilting guide will help keep the seam spacing constant.

Insert the quilting guide into the opening and set the quilting guide at the desired seam spacing.

- ① Quilting guide
- ② Opening for the quilting guide

Sew, tracing the previous row of stitching with the quilting guide.

- ③ Seam spacing

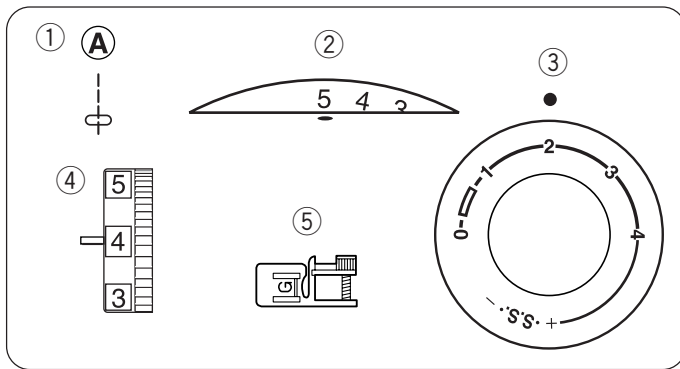

Pin Tucking

Machine setting

- ① Stitch pattern: A
- ② Stitch width: 0 or 5
- ③ Stitch length: 1.5 – 3
- ④ Thread tension: 2 – 6
- ⑤ Presser foot: Blind hemming foot G

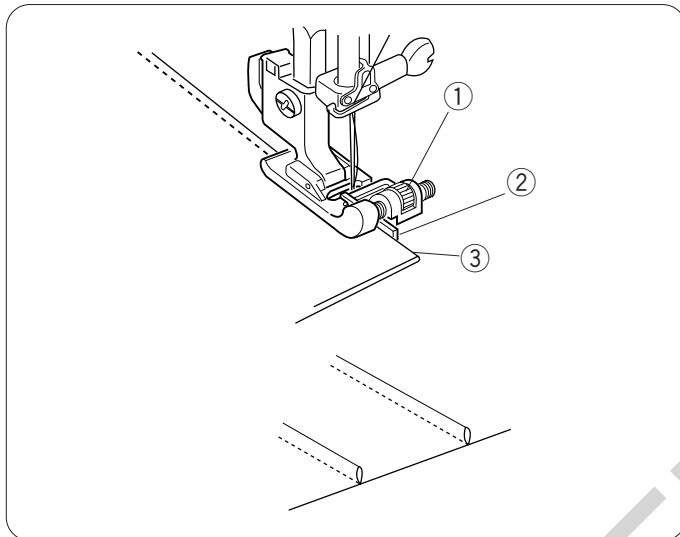

Fold a fabric wrong side together and Lower the needle into the fabric 0.1 – 0.2 cm inside the folded edge. Lower the foot and turn the screw to align the guide on the foot with the folded edge. Sew slowly while guiding the folded edge along the guide.

Open the fabric and iron press the tucks.

- ① Screw
- ② Guide
- ③ Folded edge

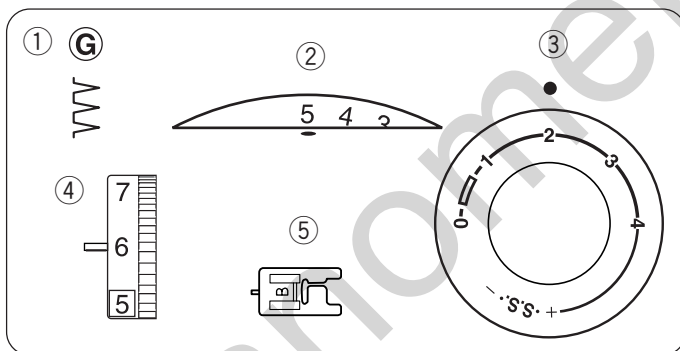

Shell Tucking

Machine setting

- ① Stitch pattern: G
- ② Stitch width: 5
- ③ Stitch length: 2 – 3
- ④ Thread tension: 6 – 8
- ⑤ Presser foot: Buttonhole foot B

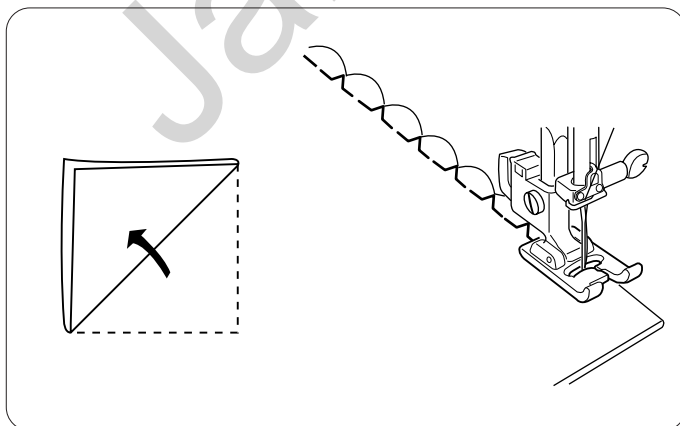

Use a lightweight fabric (tricot, for example).

Fold and stitch on the bias.

When the needle swings to the right, allow the needle to just clear the folded edge of the fabric.

After stitching, open the fabric and iron press the tucks flat to one side.

NOTE:

Increase the needle thread tension to form prominent tucks.

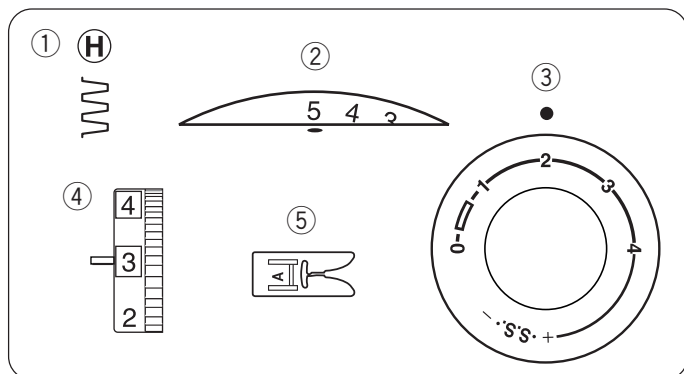

Fagoting

Machine setting

- ① Stitch pattern: H
- ② Stitch width: 3 – 5
- ③ Stitch length: 1 – 3
- ④ Thread tension: 1 – 4
- ⑤ Presser foot: Zigzag foot A

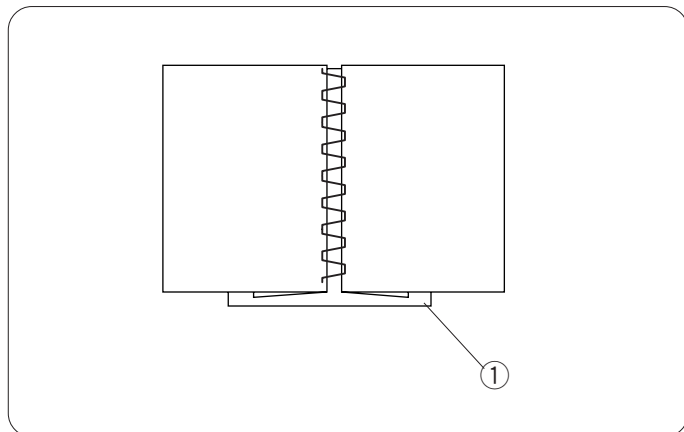

Use this stitch to join two pieces of fabric to create an open work appearance, and add design interest. Fold under each fabric edge 1/2" (1.3 cm) and press. Pin the two edges to a piece of paper or tear-away backing 1/8" (0.3 cm) apart.

- ① Paper

Sew slowly, guiding the fabric so the needle catches the folded edge on each side.

Tear away the backing after sewing is finished.

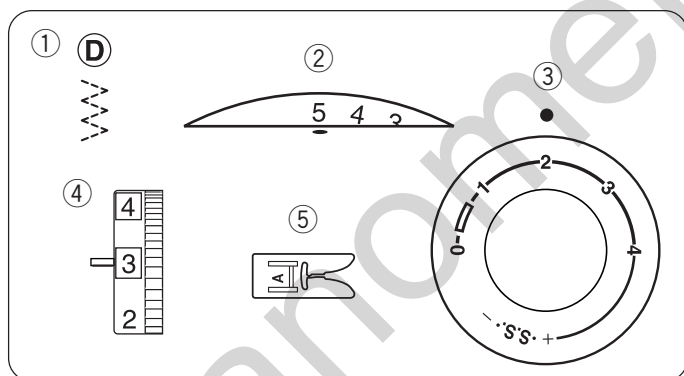

Patchwork

Machine setting

- ① Stitch pattern: D
- ② Stitch width: 5
- ③ Stitch length: 1 – 3
- ④ Thread tension: 1 – 4
- ⑤ Presser foot: Zigzag foot A

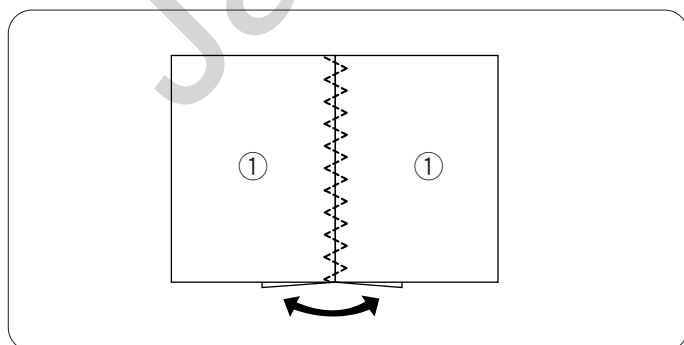

Place two layers of the fabric with the right side together. Seam along the edges with the straight stitch. Open fabrics flat and fold each seam allowances.

Place the fabric under the foot so that the seam line matches the center of the foot width.

Lower the foot and sew the pattern along the seam line.

- ① Right side of the fabric

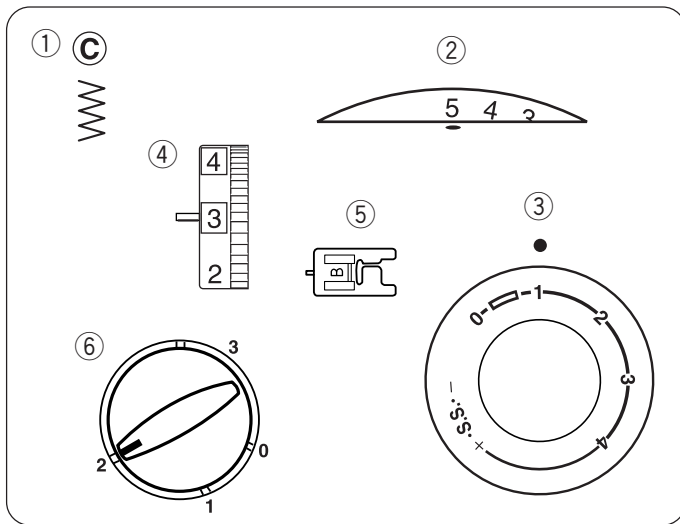

Appliqué

Machine setting

- ① Stitch pattern: C
- ② Stitch width: 3 – 5
- ③ Stitch length: 0.5 – 1
- ④ Thread tension: 1 – 4
- ⑤ Presser foot: Buttonhole foot B
- ⑥ Foot pressure: “2”

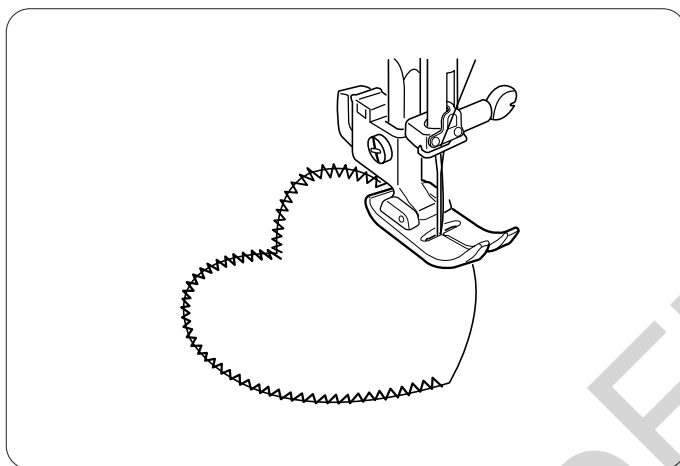

Baste appliqué pieces on the fabric, or fuse the appliqué pieces with an iron-on fabric joiner.

Stitch around the appliqué, making sure the needle at the right swing falls along the outer edge of the appliqué.

Turning the corner:

Stop the machine and lower the needle into the fabric at the outer edge of the appliqué.

Raise the presser foot and pivot the fabric into the new direction.

NOTE:

Return the foot pressure dial to “3” after finishing.

SECTION 6. CARE AND MAINTENANCE

WARNING:

Turn the power switch off and unplug the machine before cleaning.

NOTE:

Do not dismantle the machine in any way other than what is explained in this section.

Clean the outside of the machine with a soft cloth and mild soap.

Cleaning the Hook Race and Feed Dogs

- 1 Remove the presser foot and needle. Remove screw on the needle plate with the screwdriver. Remove the needle plate and take out the bobbin.

① Screw

- 2 Lift up the bobbin holder and remove it.

② Bobbin holder

- 3 Brush out dust and lint. Wipe the bobbin holder with a soft, dry cloth.

- 4 Clean the feed dogs and hook race with the lint brush.

③ Lint brush

④ Feed dogs

- 5 Wipe the hook race with a soft, dry cloth.

⑤ Hook race

NOTE:

You may also use a vacuum cleaner.

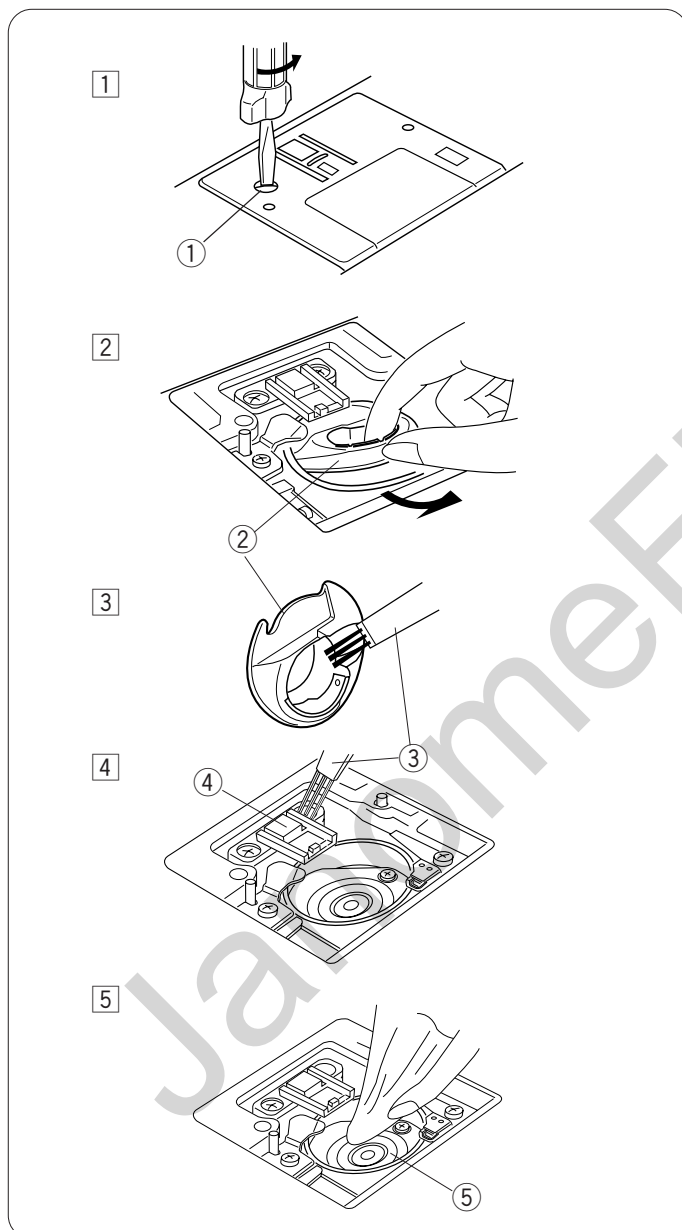

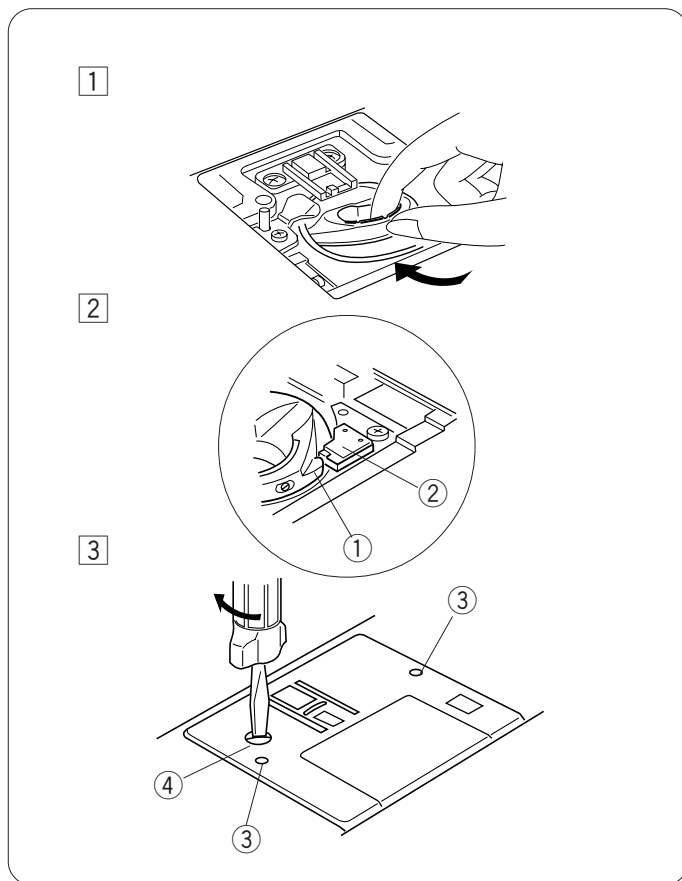

Replacing the Bobbin Holder

- 1 Insert the bobbin holder into the hook race.
- 2 Make sure the knob of the bobbin holder fits next to the stopper on the race.
 - 1 Knob
 - 2 Stopper
- 3 Replace the bobbin. Attach the needle plate, inserting the two guide pins into the holes in the needle plate. Tighten the screw firmly with the screwdriver.
 - 3 Guide holes
 - 4 Screw

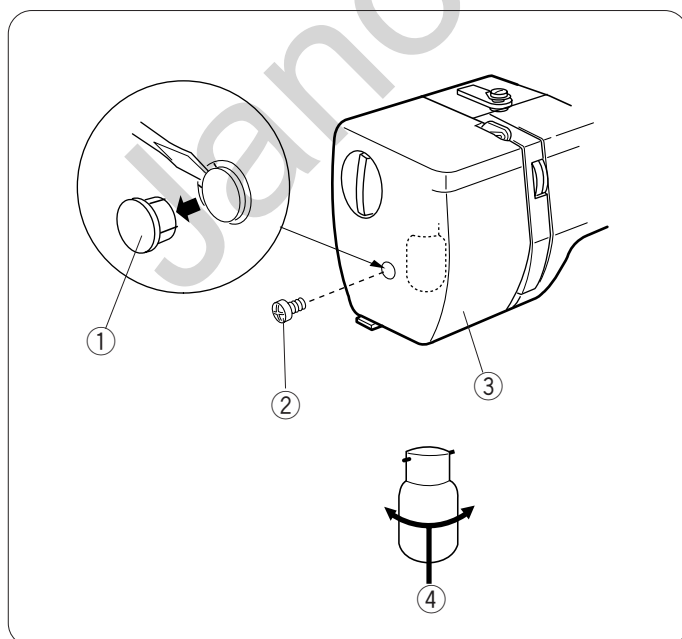

Replacing the Light Bulb

! WARNING:

When replacing the bulb, switch off and unplug the machine. Wait for the light bulb to cool down before touching it.

Remove the cap and screw. Remove the face plate.

- 1 Cap
- 2 Screw
- 3 Face plate

Push and turn the bulb counterclockwise to remove it. Push and turn the bulb clockwise to replace it.

- 4 Light bulb

Troubleshooting

Condition	Cause	Reference
The needle thread breaks.	<ol style="list-style-type: none"> 1. The needle thread is not threaded properly. 2. The needle thread tension is too tight. 3. The needle is bent or blunt. 4. The needle is incorrectly inserted. 5. The needle thread and the bobbin thread are not drawn to the rear and set properly under the presser foot when starting sewing. 6. The fabric is not drawn to the rear when sewing is finished. 7. The thread is too heavy or too fine for the needle. 	Page 10 Page 17 Page 8 Page 8 Page 18 Page 18 Page 8
The bobbin thread breaks.	<ol style="list-style-type: none"> 1. The bobbin thread is not threaded properly in the bobbin holder. 2. Lint has collected in the bobbin holder. 3. The bobbin is damaged and does not turn smoothly. 4. The thread is wound loosely on the bobbin. 	Page 11 Page 40 Replace the bobbin Re-wind the bobbin.
The needle breaks.	<ol style="list-style-type: none"> 1. Needle is incorrectly inserted. 2. The needle is bent or blunt. 3. The needle clamp screw is loose. 4. A proper foot is not used. 5. The fabric is not drawn to the rear when sewing is finished. 6. The needle is too fine for the fabric being sewn. 	Page 8 Page 8 Page 8 Use proper foot. Page 18 Page 8
The needle thread loops.	<ol style="list-style-type: none"> 1. The needle thread tension is too loose. 2. The needle size is not suitable for the thread. 	Page 17 Page 8
Skipped stitches	<ol style="list-style-type: none"> 1. The needle is incorrectly inserted. 2. The needle is bent or blunt. 3. The needle and/or thread are not suitable for the fabric being sewn. 4. A blue tip needle is not used for sewing stretch, very fine fabrics and synthetics. 5. The needle thread is not threaded properly. 6. A poor quality needle is used. 	Page 8 Page 8 Page 8 Page 8 Page 10 Replace the needle
Seam puckering	<ol style="list-style-type: none"> 1. The needle thread tension is too tight. 2. The needle thread is not threaded properly. 3. The needle is too heavy for the fabric being sewn. 4. The stitch length is too long for the fabric. <p>* Use a stabilizer for very fine fabrics.</p>	Page 17 Page 11 Page 8 Make stitch shorter
The cloth is not fed smoothly.	<ol style="list-style-type: none"> 1. The feed dog is packed with lint. 2. The stitches are too fine. 3. The feed dog was not raised after being lowered. 4. The foot pressure is not adjusted properly. 	Page 40 Make stitch longer Page 6 Page 6
The machine does not work.	<ol style="list-style-type: none"> 1. The machine is not plugged in. 2. Thread is caught in the hook race. 3. The handwheel is pulled for bobbin winding. 	Page 5 Page 40 Page 10
Patterns are distorted.	<ol style="list-style-type: none"> 1. The stitch is not balanced. 	Page 16
The buttonhole is not sewn well.	<ol style="list-style-type: none"> 1. The stitch density is not suitable for the fabric being sewn. 2. Interfacing is not being used with stretch fabrics. 	Page 26 Page 24
Noisy operation	<ol style="list-style-type: none"> 1. The feed dog is packed with lint. 2. Lint has collected in the bobbin holder. 	Page 40 Page 40
Layer slippage	<ol style="list-style-type: none"> 1. The foot pressure is not adjusted properly. 	Page 6

JanomeFlyer.com