

Effective August 24, 2020
Replaces Manual 6/27/14

JCM INDUSTRIES

Engineered Fittings Manual
Repair - Connection - Branching
All Types of Pipe

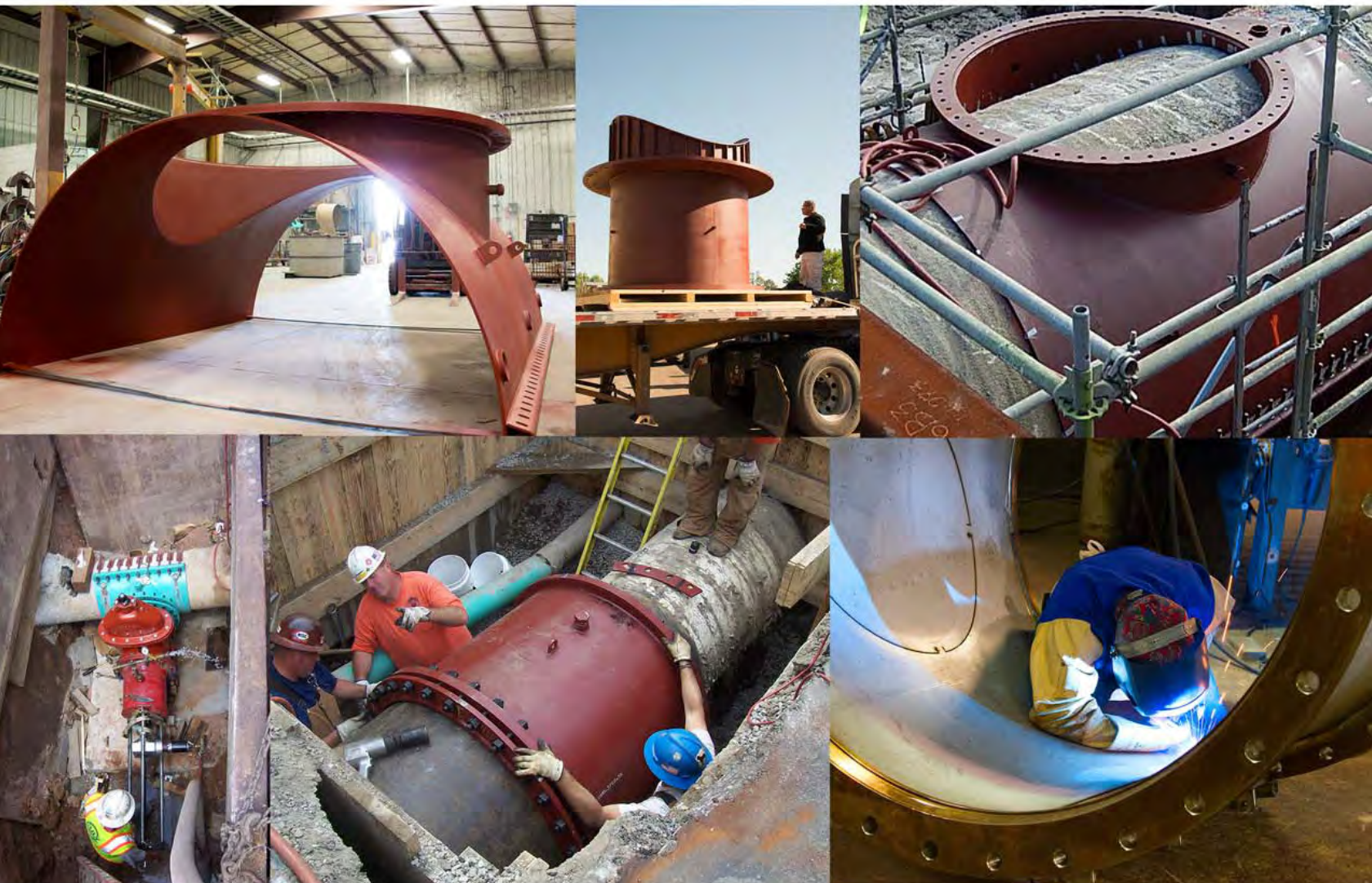

JCM Industries, Inc.

P. O. Box 1220

Nash, TX 75569-1220

Call 800-527-8482 or 903-832-2581

Fax 800-874-9524 or 903-838-6260

www.jcmindustries.com

JCM Engineered Products Manual

Product Index







Effective August 24, 2020

| JCM Engineered Repair Fittings | Page Number |
|--|--------------------|
| Engineered Repair Fitting Selection Guide | 2 |
| JCM Engineered Fitting Introduction | 3 |
| JCM 114 Mechanical Joint Repair Sleeve | 4-5 |
| JCM 116 Repair Sleeve for Concrete Steel Cylinder Pipe | 6-7 |
| JCM 118 Large Diameter and Non-Standard Contour Pipe Repair Sleeve..... | 8-9 |
| JCM 136 Heavy Duty Stainless Steel Repair Clamp..... | 10-11 |
| Technical and Engineered Product Considerations..... | 12 |
| Large Diameter Repair Factors | 13 |
| | |
| JCM Engineered Pipe Connection Fittings | |
| Engineered Connection Fittings Selection Guide | 14 |
| JCM 201 Steel Coupling..... | 15 |
| JCM 203 Steel Transition Coupling | 15 |
| JCM 204 Steel Reducing Coupling..... | 15 |
| JCM 303 Fabricated Flanged Coupling Adapter..... | 16 |
| JCM 304 Fabricated Reducing Flanged Coupling Adapter | 16 |
| JCM 230/231 HOPE Stainless Steel Stiffener | 17 |
| | |
| JCM Engineered Tapping Sleeves | |
| Engineered Tapping Sleeve Selection Guide | 18 |
| Engineered Tapping Sleeve Introduction..... | 19 |
| JCM 412 Fabricated Steel Tapping Sleeve | 20-21 |
| JCM 414 Mechanical Joint Tapping Sleeve..... | 22-23 |
| JCM 415 Tapping Sleeve for Concrete Steel Cylinder Pipe | 24-25 |
| JCM 452 All Stainless Steel Tapping Sleeve with Outlet Seal Gasket | 26-27 |
| JCM 440 Line Stop Fittings | 28-35 |
| JCM Weld on Tapping Outlets | 36 |
| | |
| JCM Engineered Fittings Product Data Sheet..... | 37 |
| | |
| JCM Specialty Engineered Fittings | |
| JCM 801/802 Expansion Joint Fittings | 38-39 |
| JCM 800 Fabricated Spools | 40-41 |
| JCM 607 Weld On Restrainer/Joint Anchor Loops..... | 42-43 |
| JCM 617 Weld On Restrainer/Joint Harness Assembly | 44-45 |
| JCM Fittings and Fabrications for High Density Polyethylene Pipe..... | 46 |
| JCM Industry Product Cross Reference Chart | 47-48 |

For JCM Industries, Inc. full product line of standard fittings and fabrications for the repair, connection and tapping of pipelines, see the JCM General Product Directory.

JCM Engineered Repair Fitting Selection Guide

JCM provides repair fittings for repairs to all types and sizes of pipe. Selection of the proper fitting is a determining factor to the success of the repair and returning the pipeline to its original service capacity. This chart is an introduction to the Engineered Repair Fittings JCM fabricates and the types of applications for which they would be considered. For specific product application recommendations, contact the JCM Sales Team.

| JCM Repair Fitting | Types of Pipe | Application |
|---|---|---|
|  <p>JCM 114 MJ Split Repair Sleeve</p> | Cast Iron Ductile Iron Asbestos Cement Steel PVC HDPE | Repairs cracks, splits, longitudinal and circumferential breaks. Especially useful for repairs to critical lines that cannot be shut down. Product is custom fabricated to accommodate all types and sizes of pipe. Pipe Sizes 4" and larger. |
|  <p>JCM 114 MJ Bell Repair Sleeve</p> | Cast Iron Ductile Iron Asbestos Cement Steel PVC HDPE | Repairs cracked cast iron bells, split or leaking couplings, leaking joints. Repair fitting "houses" the leaking connection and provides permanent water tight joint. Product is fabricated to specific application dimensions, ensuring custom fit over damaged area. Pipe Sizes 4" and larger. |
|  <p>JCM 116 Repair Sleeve for Concrete Steel Cylinder Pipe</p> | C301/SP-5/PCCP C301/SP-12/ECCP C303/SP-3/RCCP | Repairs holes, punctures, construction damage, and corroded areas on PCCP. Repairs directly on the steel cylinder preventing further corrosion damage to pipeline. Requires minimal excavation of pipeline. Pipe Sizes 14" and larger. |
|  <p>JCM 116 Repair Sleeve for Large Diameter Pipe</p> | Cast Iron Ductile Iron Steel Other large diameter rigid pipe | Repairs holes, punctures, construction damage and corrosion areas on large diameter pipe. Concentration of gasket compression around damage area allows for high working pressure capability. Pipe Sizes 14" and larger |
|  <p>JCM 136 Heavy Duty Stainless Steel Repair Sleeve</p> | Cast Iron Ductile Iron Steel Asbestos Cement PVC | Repairs holes, punctures, splits, cracks, breaks and other serious damage to pipelines. The fully gasketed stainless shell provides a complete seal on the full circumference of the pipe. Heavy duty tapping sleeve lug system provides for higher bolt torque capabilities. Pipe Sizes 4" and larger. |
|  <p>JCM 118 Fabricated Repair Sleeve</p> | Cast Iron Ductile Iron Steel Asbestos Cement PVC HDPE | Repairs holes, punctures, construction damage and corrosion areas on large diameter pipe. Accommodates application parameters such as limited space, non-standard pipe diameters, uneven pipe surfaces, out of round pipe high working pressure systems. Pipe Sizes 3" and larger. |

For standard repair fittings and applications for smaller pipe sizes, see JCM's Product Directory.

JCM Engineered Repair Fittings

Today's pipe systems have specific characteristics that place special demands on emergency repair fittings. Both large and small diameter repairs encounter critical factors to be considered that include type and size of pipe, the type and size of damage to be repaired and the system working pressure. When combined, these factors determine the design of the fitting that will be most suitable for the repair to successfully return the system to its original service rating capacity.

As service requirements grow, the full capabilities of the pipeline must not be compromised due to inappropriate repair fittings. The repair fitting design and the system's original service rating must be equally parallel in performance capabilities. This equality will insure systems ability to function as originally designed.

Careful engineering and planning of repair applications to systems and the fittings installed will prevent life threatening situations and unnecessary, unproductive downtime. To eliminate costly down-time and hazardous safety risks, JCM promotes a well planned contingency program for systems which utilize pipelines of non-standard type or maintain crucial services which cannot be shut down. JCM offers several fittings for emergency repair service in these types of systems.

JCM 114 Mechanical Joint Repair Sleeve - repairs cast iron bells, split or leaking couplings, leaking flanged joints and welded joints. The fabricated mechanical joint principle accommodates non-standard pipe diameters, out-of-round pipe, limited flat spots and fully encapsulates the problem area. Recommended for applications in which line shut down is impossible.

JCM 116 Repair Sleeve For Concrete Steel Cylinder Pipe - repairs and reinforces both Prestressed and Pretension Concrete Cylinder Pipe of all sizes. The 116 Repair Sleeve requires only minimal pipe excavation, eliminates excessive concrete coating removal, provides a wide supportive stance, maintains critical pipe integrity and has a high working pressure capability. The standard fitting repairs up through a 12" diameter damaged area. Larger repair size capability available upon request. Available on both emergency and contingency basis.

JCM 118 Large Diameter And Non-standard Contour Pipe Repair Sleeve - repairs large pipe in systems which require high working pressure capability. Engineered specifically for internal pressure forces involved with large diameter pipe and applications for unusual pipe contours and their working characteristics. Suitable for punctured and equipment damaged pipe.

JCM 114 Fabricated Mechanical Joint Repair Sleeve

Repair cast iron bells, split or leaking coupling and weld joints, or straight runs of pipe without costly shutdown or disruption to critical service.

No Shutdown or Interruption of Critical Service - by implementing a split fabricated mechanical joint design, the JCM 114 prevents costly down time and service disruption.

True Mechanical Joint Design - industrial grade, fabricated steel body and heavyweight pusher glands prevent the warpage and distortion experienced by lightweight repair sleeves using the split steel coupling designs. JCM 114 meets design criteria in AWWA C110/111, ANSI 21.10/21.11 for tolerances, dimensions and configuration of the time proven mechanical joint seal.



Custom Built For Specific Application - this versatile mechanical joint fitting is built to meet the specific requirements of special applications. Eliminates lost time due to field or factory modifications. JCM 114 sleeves are available for both limited space and full pipe section encapsulation.

Strong and Lightweight - the 114 sleeves are ideal for installations where strength, weight and continued service are critical. The reduced weight of high strength steel aids in installation and handling as well as minimizing weight load on the pipe.

**Typical Application:
Repair
Temporary/Permanent
Repair Pipe In Service**

**Cracked/Broken Pipe Joints
Splits
Holes
Failed MJ Joints, Fittings or
Couplings**

Available in Two Styles - the 114 MJ Split Repair Sleeve for use on straight runs of pipe and the 114 MJ Bell Repair Sleeve which is fabricated to accommodate the specific dimensions of the bell, collar or coupling to be repaired.

Optional Materials - the fabrication process of the 114 construction allows for various material options for the finished product. The 114 is available in carbon steel with special coatings and fasteners, or is available fabricated of all stainless steel (304, 316).

HOW TO ORDER

For pricing and engineering, the following information must be furnished:
JCM 114 is available fabricated of 304 stainless steel or 316 stainless steel
Available American Iron and Steel Compliant

JCM 114 Mechanical Joint Split Repair Sleeve

The following information must be furnished.

Type of Pipe
Pipe Outside Diameter
Length Requirements
Line Content
Line Pressure
Finish or Coating Requirements

JCM 114 Mechanical Joint Bell Repair Sleeve

The following information must be furnished.

Type of Pipe
Spigot or Pipe Outside Diameter
Largest Bell or Coupling Dimension
Length Requirements
Line Content
Line Pressure
Finish or Coating Requirements



JCM 114 Mechanical Joint Split Repair Sleeve

The **JCM 114 MJ Split Repair Sleeve** represents an unusually simple method of coupling or repairing straight runs of cracked or split cast iron pipe and severe longitudinal and circumferential breaks on critical service lines which can not be shut down. This product is made to order for all types and sizes of pipe.

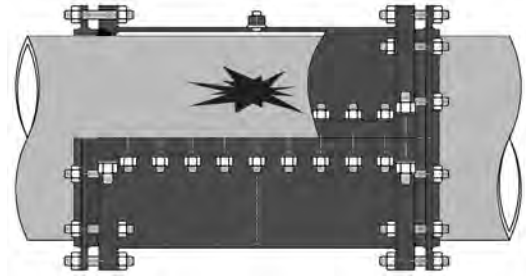

JCM 114 Mechanical Joint Bell Repair Sleeve

The **JCM 114 MJ Bell Repair Sleeve** is designed to permanently repair cracked cast iron bells, split or leaking couplings and leaking joints. By utilizing a split mechanical joint design, repairs to joints can be completed without down time or disruption to service. The JCM 114 is built to the application dimensions, ensuring a custom fit over the damaged area. These sleeves are ideal for installation where strength, weight and continued service are critical.

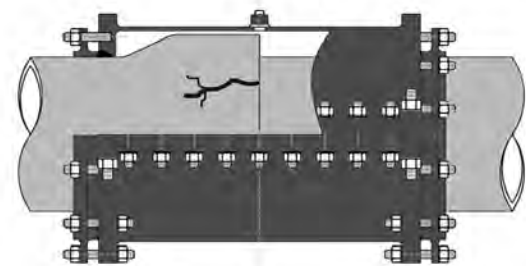

JCM 114 Fabricated Mechanical Joint Repair Sleeve - Typical Specifications

JCM 114 Mechanical Joint Split Repair Sleeve

Repair Sleeves shall be of split mechanical joint design with separate end and side gaskets. The fittings shall be constructed of high strength steel, ASTM A-36, ASTM A-516 Grade 70 or equal. The mechanical joint end dimensions shall conform to AWWA standard C-110/C-111 with modification to allow for the specific pipe repair. Sleeves shall have a 3/4" outlet for venting and test purposes. Repair Sleeves shall be JCM 114 Mechanical Joint Split Repair Sleeve or approved equal. Repair Sleeves shall be ANSI/NSF Standard 61 Certified.

JCM 114 Mechanical Joint Bell Repair Sleeve

Repair Sleeve shall be split mechanical joint, with separate end and side gaskets, designed to accommodate the pipe joint area. The fittings shall be constructed of high strength steel, ASTM A-36, ASTM A-516 Grade 70 or equal. The mechanical joint end dimensions shall conform to AWWA standard C-110/ C-111 with modification to allow for the specific pipe repair. Sleeves shall have a 3/4" outlet for venting and test purposes. Repair Sleeves shall be JCM 114 Mechanical Joint Bell Repair Sleeve or approved equal. Repair Sleeves shall be ANSI/NSF Standard 61, Annex G and ANSI/AWWA 372 Certified.

JCM 114 Mechanical Joint Repair Sleeve - Material Specifications

- BODY:** Carbon Steel per ASTM A-36, ASTM A-516 Grade 70 or equal. Optional 304 or 316 Stainless Steel.
- GLANDS:** ASTM A-36 Steel, Ductile Iron or equal. Optional 304 or 316 Stainless Steel.
- BOLTS:** Corrosion resistant, high strength low alloy A242. Optional Stainless Steel, 18-8 Type 304 or 316; Epoxy Coated Bolts.
- STUDS:** B7 Material
- GASKET:** Nitrile rubber compounded for use with water, salt solutions, mild acids and bases.
- FINISH:** Heavy coat of corrosion resistant shop coat primer. Optional Fusion Epoxy Coating (per ANSI/AWWA C-213) available.

JCM 116 Repair Sleeve for Concrete Steel Cylinder Pipe

The JCM 116 Repair Sleeve for Concrete Steel Cylinder Pipe provides a quick easy means of repairing and reinforcing damaged concrete steel cylinder pipe of all sizes. This repair sleeve permits repairs to be made on any side of the pipe - without requiring complete stripping of the concrete. The standard repair gasket seals around a 12" damaged area. Larger repair sizes are available. This sleeve is especially recommended for larger sizes of pipe and where the concrete and pipe require reinforcement.

Minimal Pipe Excavation - JCM 116 Repair Sleeve requires limited pipe exposure around the damaged area. Full section joint exposure is eliminated.

Wide Supportive Body - reinforces pipe which is weakened due to structural interruption. The body's grout seal assembly provides a system for replacement of the critical corrosion retarding concrete encasement. By restoring the concrete casing, the steel cylinder is protected from corrosive elements.

Eliminates Excessive Concrete Coating Removal - concrete removal is limited to the damaged area only, preventing further pipe structural damage

Epoxy Coated Repair Plate - the internal repair plate is fusion epoxy coated to provide a quality repair protected against corrosion in the pipe interior.

Eliminates Welding On Thin Cylinders - JCM 116 directly repairs the damaged cylinder making a watertight seal, preventing the line contents from infiltrating the concrete-steel interface.



Typical Application:
Repair
Temporary/Permanent
Repair Pipe In Service

Holes
Gouges
Fortify weakened concrete

Availability - the JCM 116 Repair Sleeve for Concrete Steel Cylinder Pipe is available from JCM on both an emergency and a contingency basis. Timely delivery and installation prevents extensive pipe damage, content loss and environmental violations.

JCM 116 Repair Sleeve for Large Diameter Pipe

The JCM 116 Repair Sleeve is also recommended for repairs on large diameter pipe including cast iron, ductile iron, steel, and other types of large diameter rigid pipe. The direct concentration of bolting pressure to the repair gland area enables the 116 to repair the damaged area while maintaining the pipeline's pressure capability.



JCM 116 Repair Sleeve for Concrete Steel Cylinder Pipe

The JCM 116 Repair sleeve provides fast, economical and permanent repairs to Concrete Pressure Pipe. Sealing around the damaged area on the steel cylinder, the JCM 116 prevents the line contents from leaking between the concrete/steel cylinder interface, and eliminates further possible damage caused by corrosion. The adjustable, separate gland seals directly on the steel cylinder over the damaged area requiring removal of the mortar coating only in the repair area. Universal grouting horns are located to accommodate re-grouting of the damaged area at any position on the pipe.

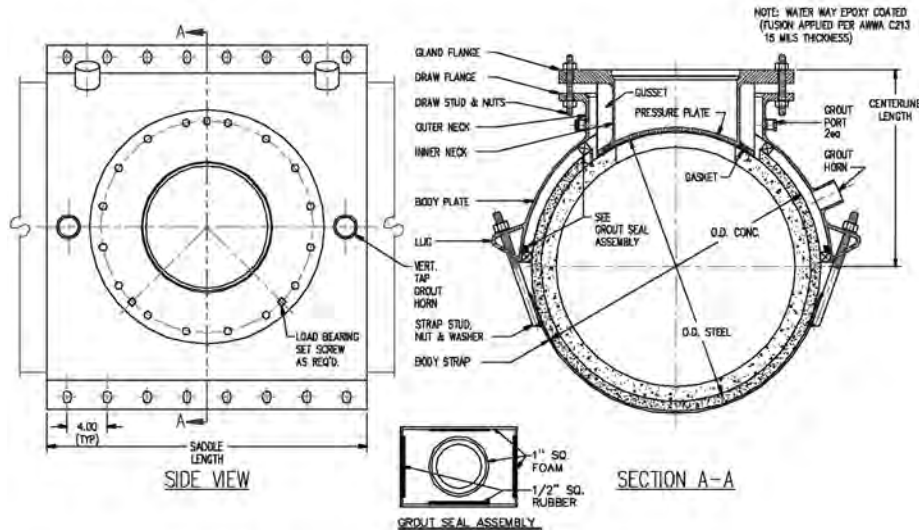

HOW TO ORDER

For pricing and engineering, the following information must be furnished:

- Type of pipe (also manufacturer and class if known)
- Diameter of damaged area
- Outside Diameter of Concrete and Cylinder
- Line Content and Pressure
- Any special requirements or options

JCM 116 Repair Sleeve for Concrete Pressure Pipe - Typical Specifications

JCM 116 Fabricated Repair Sleeves for Concrete Steel Cylinder Pipe shall be able to repair and reinforce damaged concrete steel cylinder pipe without requiring complete stripping of the concrete. The repair sleeves shall have a separate gland which permits installation and reinforcement of the pipe prior to the cutting of the prestress wires. The repair gland shall have a fusion epoxy coated pressure plate and a broad gasket set in a retaining groove of the pressure plate which is gusseted to eliminate flexing. Repair Sleeves shall be JCM 116 Repair Sleeves or approved equal. Repair Sleeves shall be ANSI/NSF Standard 61, Annex G and ANSI/AWWA 372 Certified.

JCM 116 Repair Sleeve For Concrete Pressure Pipe - Material Specifications

- BODY:** Carbon Steel per ASTM A-36, ASTM A-516 Grade 70 or equal.
- GASKET:** Nitrile rubber compounded for use with water, salt solutions, mild acids, bases and sewage.
- BOLTS:** Corrosion resistant, high strength low alloy A242. Optional Stainless Steel, 18-8 Type 304.
- DRAW HARDWARE:** B7 Material
- COATING:** Heavy coat of corrosion resistant shop coat primer on sleeve, gland and straps. Pressure plate of gland is epoxy coated (fusion applied per ANSI/AWWA C-213). Optional epoxy coating on entire sleeve.

JCM 118 Large Diameter and Non-Standard Contour Pipe Fabricated Repair Sleeve

The JCM 118 Repair Sleeve repairs pipe in systems which require high working pressure capability. Engineered specifically for the internal pressure forces involved with large diameter pipe and its working characteristics. The JCM 118 Sleeve is available in pipe sizes up through 120" and larger and provides several design options for the specific application.

Minimal Pipe Excavation - the 118 sleeve requires limited pipe exposure around the damaged area. Full section joint exposure is eliminated.

Reinforcement Pipe Wall - strong and lightweight steel directly reinforces the pipe wall on the circumference of the pipe.

Heavy Duty Design - large fitting components, spacious bolt holes and heavy hardware combine to make installations in less than ideal environments easy and fast. The 118 especially lends itself for easy underwater and low visibility applications.

Maximum Gasket Sealing - heavy duty bolts and material provides high levels of bolt torque which is transferred directly to gasket sealing compression. Higher bolt torques maintain greater working pressures.

Low Profile Stance - the hydro-mechanical lip gasket is trapped both internally and externally in a recessed groove that provides a low profile stance on the pipe eliminating the chance of gasket displacement or "blow-out" in high pressure applications.

Availability - the JCM 118 Repair Sleeve is available from JCM on both an emergency and a contingency basis. Timely delivery and installation prevents extensive pipe damage, content loss and environmental violations.



Typical Application:
Repair
Temporary/Permanent
Especially Recommended for
Large Diameter Pipe
High Working Pressures

Splits
Holes
Punctures
Corroded Areas
Gouges

JCM 118 Large Diameter Repair Sleeve Offers Application Specific Options

JCM 118 is available fabricated of 304 stainless steel or 316 stainless steel

The JCM 118 Repair Sleeve is recommended for applications on large diameter pipe, high working pressure systems and critical service applications. The 118 provides a variety of fabrication options for consideration such as space limitations, environment and service requirements.

These special fabrication options include:

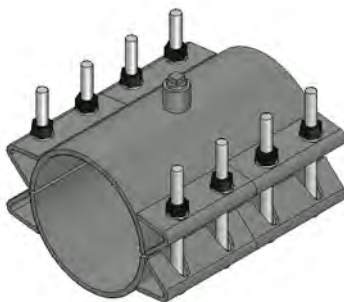

- Laying Length
- Pipe Range
- Gasket
- Coating
- Body Material
- Damaged area accommodation
- Hardware

**JCM 118 Repair Sleeve - Available in
Carbon Steel or Stainless Steel (304-316)**



JCM 118 Large Diameter and Non-Standard Contour Pipe Fabricated Repair Sleeve

JCM provides various options for the JCM 118 Large Diameter Pipe Repair Sleeve. For special engineered fittings, contact the JCM Technical Services Sales Team and provide the application parameters. JCM will provide recommendations for the application and custom design the fitting to accommodate those parameters.

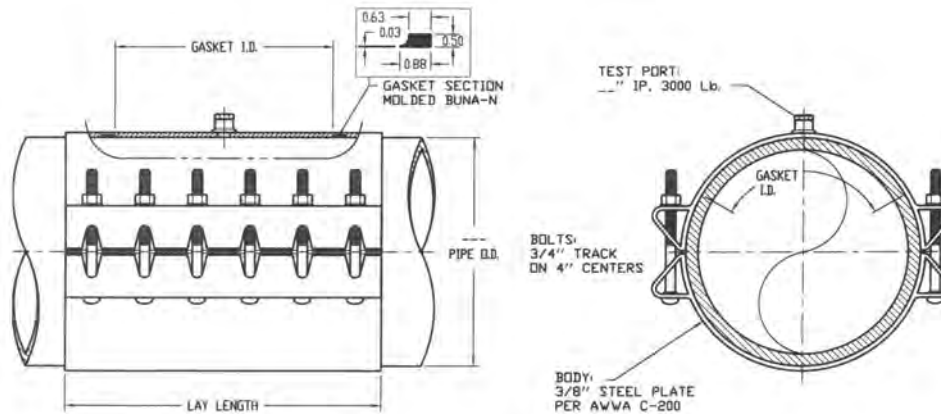

JCM 118 Large Diameter Repair Sleeve - Standard Design

HOW TO ORDER

For pricing and engineering, the following information must be furnished:

| | |
|--|--|
| Type of Pipe Pipe Outside Diameter Line Content Line Working Pressure | Dimension of Damaged Area Space Limitations Coating Requirements Optional Material Requirements |
|--|--|

JCM 118 Fabricated Repair Sleeve - Standard Fitting Typical Specification

Repair fittings shall be the high strength type fabricated of Carbon Steel per ASTM A-36, A-516 Grade 70 or equal, which conforms to and reinforces the pipe. Sleeve shall be minimum 8" wide and be sized to fit and reinforce the pipe circumference. Sleeve repair area shall have a minimum 3/4" wide Buna-N gasket recessed in a machined groove. Repair fitting shall have a 3/4" outlet for venting and test purposes. Repair fitting shall be furnished with a corrosion resistant shop coat paint primer with high strength, low alloy corrosion resistant bolts and nuts (AWWA C-111, ANSI 21.11). Repair Sleeves shall be ANSI/NSF Standard 61, Annex G and ANSI/AWWA 372 Certified.

JCM 118 Large Diameter Pipe Repair Sleeve - Material Specifications

| | |
|-----------------|---|
| BODY: | Carbon Steel per ASTM A-36, ASTM A-516 Grade 70 or equal. Optional 304 or 316 Stainless Steel. |
| BOLTS: | Corrosion resistant, high strength low alloy A242. Optional Stainless Steel, 18-8 Type 304 or 316; Electro Coated Bolts. |
| GASKET: | Nitrile rubber compounded for use with water, salt solutions, mild acids and bases. |
| COATING: | Heavy coat of corrosion resistant shop coat primer, an excellent base for bitumastic coal tar or similar field coatings. Optional Fusion Epoxy Coating (per ANSI/AWWA C-213) available. |

JCM 136 Heavy Duty Stainless Repair Clamp Coupling

The JCM 136 Heavy Duty Stainless Steel Repair Clamp incorporates the corrosion resistance of stainless steel, the full circumferential gasketing of a Universal Clamp Coupling and the triangular bolting configuration of the 432 Stainless Steel Tapping Sleeve to provide a repair clamp coupling with high working pressure capabilities.

All Stainless Steel Construction - provides superior corrosion resistance in harsh or acidic environments. The JCM 136 is available fabricated of 304 or 316 stainless steel.

Heavy Duty Stainless Material - the JCM 136 has a minimum standard material of 14 gauge certifiable prime material. This strong, yet flexible stainless shell conforms to uneven or unusual pipe surfaces and provides complete compression of the gasket on the pipe wall.

Tapping Sleeve Bolting System - with a triangular lug design, allows for pass-through, replaceable bolts. This lug configuration eliminates alignment problems and allows tightening from either side of the pipe.

Full Circumferential Gasket - provides a water tight seal on the full circumference of the pipe. The gridded 1/4" thick gasket is of a durometer hardness that allows the rubber to conform to and fill the pits and voids of uneven pipe surfaces.

The JCM 136 Heavy Duty Stainless Repair Clamp is available for all types and sizes of pipe. Options for this fitting includes: 304 Stainless Steel, 316 Stainless Steel, SBR, EPDM or Buna-N Gaskets, 304 Stainless Hardware, 316 Stainless Hardware. Call the JCM Inside Sales Team for product recommendations.

The JCM 136 Heavy Duty Stainless Repair Clamp larger than 16" nominal pipe size may include multiple bands. Contact JCM for information.



Typical Application:
Repair
Temporary/Permanent
*Especially Recommended for
High Working Pressures*

Breaks
Cracks
Splits
Holes
Corroded Areas
Gouges

JCM 136 Heavy Duty Stainless Steel Repair Clamp Coupling

All Stainless Steel Body

Full Circumferential Gasket
1/4" Thick

Recessed Stainless Steel
Bridge Plates

Heavy Duty Stainless Bolting
System

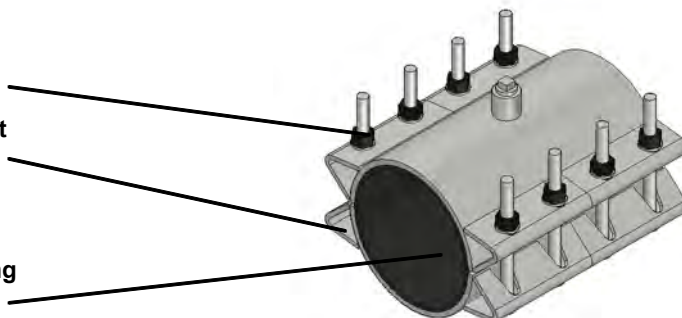

JCM 136 Heavy Duty Stainless Repair Clamp Coupling

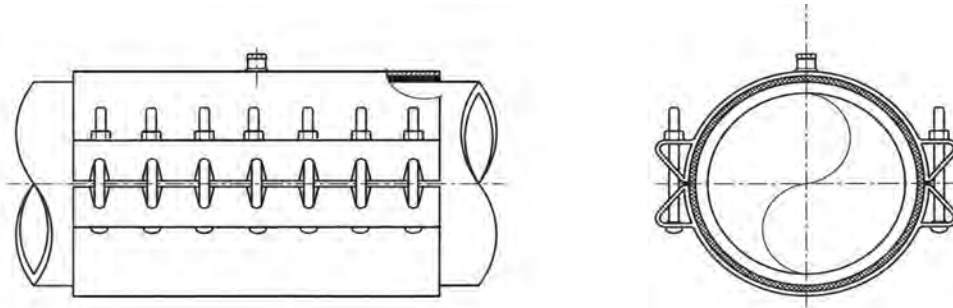

JCM 136 Heavy Duty All Stainless Repair Clamp Coupling - Standard Design

HOW TO ORDER

For pricing and engineering, the following information must be furnished:

| | |
|-----------------------|--------------------------------|
| Type of Pipe | Dimension of Damaged Area |
| Pipe Outside Diameter | Space Limitations |
| Line Content | Coating Requirements |
| Line Working Pressure | Optional Material Requirements |

JCM 136 Heavy Duty All Stainless Repair Clamp Coupling - Typical Specifications

All heavy duty repair clamps shall have a minimum material standard of 14 gauge certifiable prime 304 stainless steel construction. Clamps shall have a triangular lug design with bolts on 3" centers. Bolts shall be the pass-through, replaceable type to avoid alignment problems and allow tightening from either side of the pipe. Bolts shall not be integrally welded to the sleeve. Bolts shall be minimum 5/8" 304 stainless steel track head type furnished with permanently lubricated heavy hex nuts and stainless steel washers. The full circumferential gasket shall be molded of synthetic rubber compounded for use with water salt solutions, mild acids, bases and sewage. The gasket shall have a gridded surface, be a full 1/4" thick with 304 stainless steel bridge plates molded flush into the gasket. Clamps shall be fully passivated to insure corrosion resistance. Heavy duty clamps shall be JCM 136 All Stainless Steel Heavy Duty Repair Clamp Coupling or approved equal. Repair Clamps shall be ANSI/NSF Standard 61, Annex G and ANSI/AWWA 372 Certified.

JCM 136 Heavy Duty All Stainless Repair Clamp Coupling- Material Specifications

- BODY:** Stainless Steel 18-8 Type 304.
- LUGS:** Stainless Steel 18-8 Type 304.
- BOLTS:** Stainless Steel 18-8 Type 304.
- GASKET:** The full circumferential gasket shall be molded of synthetic SBR rubber compounded for use with water salt solutions, mild acids, bases and sewage. The gasket shall have a gridded surface, be a full 1/4" thick with 304 stainless steel bridge plates molded flush into the gasket. Optional EPDM gasket available.

Optional All 316 Stainless Steel Repair Clamp available. Contact JCM Industries for information.

JCM Technical and Engineered Products

JCM Engineered Products are designed and built to accommodate the special needs of today's piping applications. The growing demands made on water, wastewater, industrial and irrigation piping systems, which provide critical and expanded services, put stresses and forces never before experienced on the pipe and its fittings.

To eliminate unnecessary and life threatening interruption of services, repair and expansion applications to these systems must take several factors into consideration. These crucial factors include: type of pipe, size of pipe, working pressure, type and size of application. These very important considerations will determine the type of fitting to be utilized to successfully complete the job and maintain the system's original flow and service rating capacity.

Changes in piping materials and service requirements in current systems, require fittings that will accommodate characteristic fluctuations and withstand the growing service demands of the system. JCM Engineered Products provide the solution for these requirements.

In-service systems, especially those with large diameter pipe, offer special application considerations commonly involving irregular and out-of-round pipe, non-standard pipe diameters and high working pressures. JCM Engineered Products for large diameter pipe are time and field proven for performance and reliability. By monitoring field applications and their requirements JCM is able to provide the piping industry the most advanced engineering designs for large diameter pipe.

JCM offers experienced service throughout the organization. Sales personnel are technically trained to assist with special applications. This assistance is supported by experienced production engineers and manufacturing staff knowledgeable in design fabrication.

JCM invites inquiries from all phases of the piping industry. Engineered products are designed for and can be adapted to all types of pipe and line contents.

JCM Large Diameter Repair Clamps Selection and Application

In the repair applications to large diameter pipe, there are several factors to be considered to maintain pipe integrity and return to 100% service capacity. These factors, which are critical to the application, include: size and type of pipe, severity of damage, working pressure or service requirements, location of repair and time factor.

Line pressure forces encountered in repair applications will determine the success or failure of a repair fitting. The forces of large pipe reduce the working capability and safety factor of large repair clamps. Performance of these fittings is determined by the relationship of bolting power to gasket area, fastener attachment, bolt efficiency and thickness of metal. Therefore, a repair clamp may not be the proper fitting for certain applications. JCM offers various repair fittings which are suitable for repairs to large pipe operating at higher working pressures. To understand the forces involved in the application, see the comparison values listed below relating size of pipe to the internal forces involved.







| Nominal Pipe Size (In.) | Outside Diameter | Area of 1/4" Break | Stress/Force on Clamp at 100 PSI |
|-------------------------|------------------|--------------------|----------------------------------|
| 12 | 13.20 | 10.37 sq. in. | 1,037 lbs. PSI |
| 16 | 17.40 | 13.67 sq. in. | 1,367 lbs. PSI |
| 20 | 21.60 | 16.96 sq. in. | 1,696 lbs. PSI |
| 24 | 25.80 | 20.26 sq. in. | 2,026 lbs. PSI |
| 30 | 32.00 | 25.13 sq. in. | 2,513 lbs. PSI |

On a repair clamp the mechanical seal is made by tightening bolts to create a greater force on the gasket (PSI) than is in the pipeline. Safety factor is that amount of sealing capability the clamp has above the operating pressure of the pipeline.

Clamps are limited in performance by the relationship of bolting power to gasket area. Also entering into the picture are the fastener attachment, bolt efficiency and the thickness of the metal.

JCM clamps have been designed to limit traditional clamp weaknesses, thereby giving a higher working capability and safety factor. Even so, they do have a limited capability. Other types of repair fittings should be taken into consideration. Fabricated repair sleeves are designed to overcome the forces involved with large diameter pipe and its characteristics.

JCM Engineered Connection Fitting Selection Guide

| JCM Coupling Fitting | Types of Pipe | Application |
|--|--|---|
|  <p style="text-align: center;">JCM 201 Steel Coupling</p> | Cast Iron Ductile Iron Steel PVC HDPE Other Types | For joining plain end pipe. Implements the principle of bolted gasket compression. Easy to install, eliminates costly pipe threading, beveling, exact alignment and other downtime pipe preparations. Available in both common and custom sizes and widths. |
|  <p style="text-align: center;">JCM 203 Steel Transition Coupling</p> | Cast Iron Ductile Iron Steel PVC HDPE Other Types | Simple means of joining plain end pipe in the same nominal size with different outside diameter dimensions. Available in both common and custom sizes and widths. |
|  <p style="text-align: center;">JCM 204 Reducing Coupling</p> | Cast Iron Ductile Iron Steel PVC HDPE Other Types | The answer to joining plain end pipe of two different nominal sizes. Available in both common and custom sizes and widths. |
|  <p style="text-align: center;">JCM 303 Flanged Coupling Adapter</p> | Cast Iron Ductile Iron Steel PVC HDPE Other Types | Flanged adapters provide the means of joining the same nominal pipe size of plain end pipe to flanged fittings within the piping system. Available with optional types of flanges, lengths, restraint systems, coatings, hardware and more. |
|  <p style="text-align: center;">JCM 304 Reducing Flanged Coupling Adapter</p> | Cast Iron Ductile Iron Steel PVC HDPE Other Types | Flanged adapters provide the means of joining plain end pipe to flanged fittings with different nominal pipe size within the piping system increasing or decreasing sizes. Available with optional types of flanges, lengths, restraint systems, coatings, hardware and more. |
|  <p style="text-align: center;">JCM 309 Dismantling Joint</p> | Cast Iron Ductile Iron Steel PVC HDPE Other Types | JCM 309 Dismantling Joints provide the solution for adding, repairing or replacing flanged fittings within a flanged pipe system. Adjustable, slip joint design accommodates either wide gaps or close quarter installations and eliminates the need for precise measurements between flange connections. |

JCM Steel Couplings



JCM 201 Steel Bolted Couplings

JCM 201 Steel Couplings provide an easy means of joining plain end pipe. These couplings are especially applicable for use on steel, galvanized, PVC and other pipe with standard steel dimensions.

Implementing the principle of bolted gasket compression, the JCM 201 Steel couplings are easy to install and eliminates time consuming costly threading, beveling, exact pipe alignment and other downtime preparations.

Available in both common and custom sizes with optional coatings, gaskets and hardware combinations. Pipe Sizes 1/2" and larger.

JCM 203 Steel Transition Couplings

The JCM 203 Steel Transition Coupling provides a simple means of joining plain end pipe of the same nominal size but different outside diameter dimensions. Available in common sizes for Cast Iron, Ductile Iron, PVC, HDPE and others. Non-standard sizes available upon request. Pipe Sizes 3" and larger



JCM 204 Steel Reducing Couplings

The JCM 204 Steel Reducing Coupling is the simplest means of connecting any combination of two sizes or types of pipe. There is practically no limit to the pipe sizes that can be connected - either to reduce or increase in size. Pipe Sizes 4" and larger.

Typical Application:
Connection/Repair
Temporary/Permanent
Join Plain End Pipe
Install Repair Section of Pipe
Transition or Reduce between two pipe sizes

Applications in which pipe may move out of the coupling, correct anchorage of the pipe must be provided.

For applications on HDPE Pipe, JCM Recommends the use of of the JCM 230/231 Stainless Steel Pipe Stiffener and JCM 600 Series Pipe Restrainers.

JCM Flanged Adapters and Dismantling Joints

JCM 303 Fabricated Flanged Coupling Adapters

JCM 304 Fabricated Reducing Flanged Coupling Adapters

The JCM 303 Fabricated Flanged Coupling Adapter provides a simple means of joining plain end pipe to flanged fittings, valves and equipment. Ideal for installing flanged valves, backflow preventors, monitoring equipment and other pipeline accessories to be retrofitted into a piping system. Fabricated without pipe stops, the JCM 303 Flanged Adapter can be slid back on the plain end pipe for quick fitting installation and adjustment. Available in either size on size or reducing sizes (JCM 304), optional coatings and hardware and flange types.



Optional Flanges Available -
ANSI/AWWA C207 Class D, ANSI 150 Drilling
ASME/ANSI B16.5 Class 150, 300
Weld Neck, Blind, Slip-on, Reducing,
Threaded, Socket Weld, Lap Joint,
Angle Face, Van Stone
Concentric and Eccentric Flanges

Pipe Sizes 3" and larger

JCM 309 Fabricated Dismantling Joints

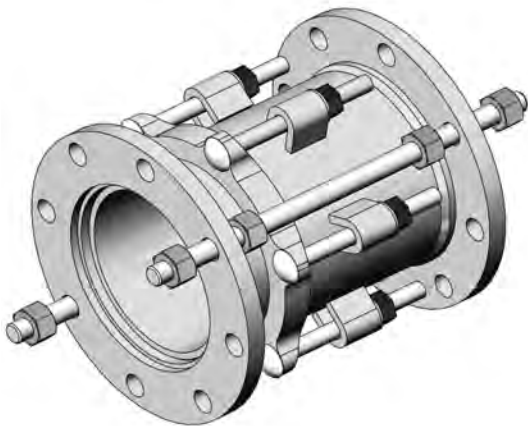

Dismantling joints simplify installations and replacement of flanged fittings in retrofitting applications. JCM 309 Dismantling Joints provide the solution for adding, repairing or replacing flanged fittings within a flanged pipe system. Adjustable, slip joint design accommodates either wide gaps or close quarter installations and eliminates the need for precise measurements between flange connections. Restrained design standard. Available in sizes 2" (50mm) and larger, for ductile iron or flanged steel pipe systems.

JCM 309 Dismantling Joints Offer:

- Greater longitudinal adjustment ability speeds installations and reduce system downtime.
- Accommodates future modifications and system adjustments.
- Simplifies installation - one fitting integrates into system operating as flanged adapter and an adjustable spool piece.

Material Specifications - 201, 203, 204

MIDDLE RING: Carbon Steel per ASTM A-36 or equal.

FOLLOWERS: 1/2" - 12" Ductile Iron ASTM A-536 or equal; 14" and larger: ASTM A36

BOLTS: 1/2" through 2": ASTM A242 low alloy with yellow dichromate seal. Sizes 2-1/2" and larger: Corrosion resistant, high strength low alloy ASTM A242, A193 B5, B7. Optional A193 B8 304 stainless steel or 316 stainless steel.

GASKETS: Nitrile Butadiene Rubber (NBR, Buna-N) per ASTM D2000. Molded virgin rubber. Gasket temperature range -40°F to 212°F (-40°C - 100°C) Recommended for water, salt solutions, mild acids, bases, sewage and natural gas. Optional: EPDM

FINISH: Heavy coat of corrosion resistant shop coat primer. Optional Fusion Epoxy Coating available.

303, 304, 309: ANSI/AWWA C207 Class D Flange with ANSI 150 lb. drilling, ASME/ANSI B16.1 Class 125 Compatible Steel Ring Flange or equal

JCM 200 and 300 Series fittings are ANSI/NSF Standard 61, Annex G and ANSI/NSF Standard 372 Certified.

JCM 200 and 300 Series fittings meet ANSI/AWWA Standard C219 as applicable.

JCM 230/231 Stainless Steel Stiffeners for HDPE Pipe

For applications on High Density Polyethylene Pipe, using mechanical bolt on fittings to join or connection systems, JCM recommends the use of the JCM 230/231 Stainless Steel Pipe Stiffeners. JCM 230/231 Stiffeners provide:

- Corrosion Resistance
- Rigid Reinforcement of Pipe Wall for Pipe Connections
- Accurate Pipe I.D. Sizing maintains proper Outside Diameter
- 1/8" Tapered Insert End provides for Easy Installation
- 90° 1/8" Flared End Secures Stiffener to End of Pipe
- Positive Reinforcement without interference







JCM HDPE Pipe Stiffeners are designed to support the interior wall of HDPE for critical pipe joining applications. Recommended for all pipe end connections utilizing mechanical bolt-on fittings, the JCM Pipe Stiffeners support the pipe's end and controls the "necking down" reaction to the pressure applied during normal installation of fittings used in pipe joining applications.

The JCM HDPE Pipe Stiffeners are formed of stainless steel, 304 or 316 material, to the actual inside pipe diameter provided by the customer. This accurate formation provides for ease of installation and maintains the proper outside diameter for a successful, trouble free application that provides long-term service.

JCM Pipe Stiffeners are available for Steel Size and Ductile Iron Size HDPE in SDR11, 13.5, 17, 21, 26, 32.5

JCM Pipe Stiffeners Material Specifications: ASTM A240 - TP 304 Stainless Steel or 316 Stainless Steel

JCM Engineered Tapping Sleeves

| JCM Tapping Fitting | Types of Pipe | Application |
|--|--|--|
|  <p>JCM 412 Fabricated Steel Tapping Sleeve</p> | Cast Iron Ductile Iron Asbestos Cement Steel PVC HDPE Reinforced Concrete Other various types | For tapping both rigid and non-rigid types of pipe. Especially recommended for applications on systems with fluctuating or high working pressure requirements. Individual engineering and fabrication ensures a close, custom fit to unusual or non-standard pipe surface characteristics. Pipe sizes 6" and larger. |
|  <p>JCM 452 All Stainless Steel Tapping Sleeve</p> | Cast Iron Ductile Iron Asbestos Cement Steel PVC HDPE Reinforced Concrete Other various types | For tapping both rigid and non-rigid types of pipe in corrosive or acidic environments. All stainless construction combines superior corrosion resistance with high working pressure capabilities. Manufactured to provide maximum corrosion resistance in applications on mains which are not subject to beam breaks. Pipe sizes 6" and larger. |
|  <p>JCM 414 Fabricated Mechanical Joint Tapping Sleeve</p> | Cast Iron Ductile Iron Asbestos Cement Steel Other various types | For tapping pipelines which are subject to beam breaks and where strength, weight and beam load considerations are critical. Lightweight, yet strong, fabricated steel construction ensures a close, custom fit to older, out-of-round or non-standard pipe surfaces. True mechanical joint design encompasses the tap area and seals completely around the pipe. Pipe sizes 14" and larger. |
|  <p>JCM 415 Tapping Sleeve for Concrete Steel Cylinder Pipe</p> | C301/SP-5/PCCP C301/SP-12/ECCP C303/SP-3/RCCP | For tapping both Prestress and Prestension Concrete Steel Cylinder Pipe. Designed to meet the AWWA M-9 Manual. Provides reinforcement of the pipe and easy installation with maximum safety factor. Special requirements and modifications are easily adapted to the 415. Manufacturing flexibility accommodates modifications, adaptations and special engineering requirements without delay in product availability. Pipe sizes 14" and larger. |
|  <p>JCM 440 Line Stop Fitting</p> | Cast Iron Ductile Iron Asbestos Cement Steel PVC HDPE Other various types | Engineered for line stopping applications on all types of pipe. Adapts to all popular line stopping machines. Heavy duty standard design provides a 150 PSI working pressure capability. Catalog pipesizes 4" - 12". Larger line stop fittings (14" and larger) available, for information contact JCM Technical and Engineered Sales. |

JCM Engineered Tapping Sleeves

JCM Engineered Tapping Sleeves are designed and built to accommodate the special needs of today's piping applications. The growing demands made on water, wastewater, industrial and irrigation piping systems, which provide critical and expanded services, put stresses and forces never before experienced on the pipe and its fittings.

To eliminate unnecessary and life threatening interruption of services, expansion applications to these systems must take several factors into consideration. These crucial factors include: type of pipe, size of pipe, working pressure, type and size of application. These very important considerations will determine the type of fitting to be utilized to successfully complete the job and maintain the system's original flow and service rating capacity.

Changes in piping materials and service requirements in current systems, require fittings that will accommodate characteristic fluctuations and withstand the growing service demands of the system. JCM Engineered Tapping Sleeves provide the solution for these requirements.

Existing service systems, especially large diameter systems, offer special application considerations commonly involving irregular and out-of-round pipe, non-standard pipe diameters and high working pressures. JCM Engineered Tapping Sleeves for large diameter pipe are time and field proven for performance and reliability. Monitoring field applications and requirements enables JCM to provide the most engineering advanced designs for large diameter pipe to the industry. These fittings include:

JCM 412 Fabricated Tapping Sleeves - built-in benefits make these heavy fabricated steel sleeves increasingly popular for making larger taps on all types of pipe. By placing the design emphasis on eliminating problems inherent with older pipe and field installations, JCM 412 Tapping Sleeves have taken the complexity out of tapping larger pipe.

JCM 452 All Stainless Steel Tapping Sleeves - incorporates the heavy duty design of the fabricated steel tapping sleeve with the corrosion resistance of all stainless steel. This heavy design utilizes a broad cross section, hydromechanical outlet gasket in lieu of the full body gasket. The JCM 452 is engineered for installations requiring higher working pressure, higher safety factor or longer service life than standard all stainless or cast iron sleeves and is manufactured to provide superior corrosion resistance in applications on mains which are not subject to beam breaks. Available in 316 stainless steel.

JCM 414 Fabricated Mechanical Joint Tapping Sleeves - combines the high strength and versatility of fabricated steel with the traditional side and end gasketed mechanical joint design. These sleeves are ideal for potential problem installations where strength, weight and beam load considerations are critical. Available in 304 or 316 stainless steel.

JCM 415 Tapping Sleeve for Concrete Steel Cylinder Pipe - is designed to reinforce the pipe and provide easy installation with maximum safety factor. The 415 provides a separate body and tapping gland. By separating the outlet gland from the sleeve body, the sleeve reinforces the pipe prior to removal of the critical prestress wire from the outlet area. JCM 415 Tapping Sleeves are in accordance with the AWWA M-9 Manual. Available in 304 or 316 stainless steel.

JCM 412 Fabricated Tapping Sleeve

Built-in benefits make these heavy fabricated steel sleeves increasingly popular for making larger taps on all types of pipe. By placing the design emphasis on eliminating problems inherent with older pipe and field installations, JCM 412 Tapping Sleeves have taken the complexity out of tapping larger pipe.

Custom Engineered Range - assures proper fit on the pipe. Non-standard, oversized, undersized and out of round pipe is easily accommodated in the manufacturing process.

Ease Of Assembly - eliminates extra equipment, time and specially trained personnel.

Readily Available - means taps can be made without long delays - even taps on special sizes of pipe - or services requiring high pressure flanges.

Direct Reinforcement Of Pipe - by sleeve eliminates flexing or pipe deflection of opposite the tap. Less weight than heavy cast iron sleeves reduces the load on the pipe.



JCM 412 Tapping Sleeves Assure A Safe Dependable Tap - a large gasket cross section provides a positive initial seal which increases with increases in line pressure. The built-in test plug provides a means of checking all seals prior to beginning the tap.

Options - the JCM 412 offers a wide variety of options to ensure a successful long term fitting installation for non-standard or custom applications. These engineering options include:

- Flanges - AWWA C207, Class E, Class F, ANSI 150, ANSI 300, Raised Face, Mechanical Joint, Vanstone and other optional flanges
- Outlets - Offset, Angle, Material Thickness
- Body - Laying Length, Material Grade, Material Thickness
- Coating - Shop Coat Primer, Fusion Applied Epoxy, Bitumastic and other various coatings
- Hardware - Standard Alloy, Stainless Steel

Various other options, call for availability

JCM provides engineering recommendations for all types of applications for the JCM Tapping Sleeves. Call the JCM Inside Sales Team with your job requirements for submittal.

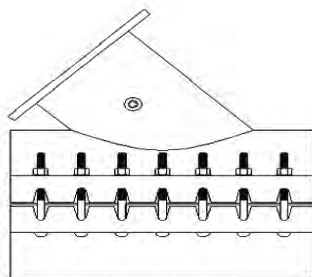

Outlets at 45° angle.

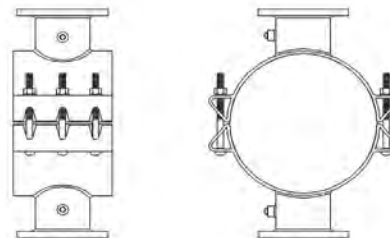

Fabricated tapping cross accommodates multi-branch applications.



JCM 412 Fabricated Tapping Sleeve

The JCM 412 Fabricated Tapping Sleeve is a safe, economical solution to tapping today's pipelines. Custom engineering service assures proper fit and conformation to the pipe diameter increasing safety factor and installation efficiency. By directly reinforcing the pipe, the sleeve eliminates flexing or deflection of the pipe opposite of the tap. The large cross section gasket provides a positive initial seal which increases with increases in line pressure. The JCM 412 Tapping Sleeve is available in various option styles and materials. Call the JCM Sales Team with your requirements.

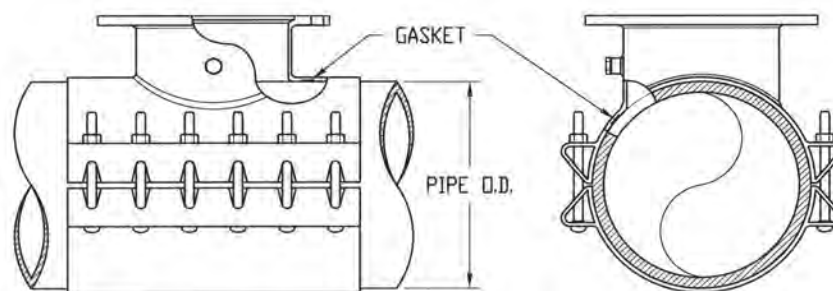

JCM 412 Fabricated Tapping Sleeve - Typical Specifications

Tapping Sleeves shall be the high strength type having a wide body, made of ASTM A-36, ASTM A-516 Grade 70 or equal which conforms to and reinforces the pipe. The sleeves shall have as a minimum 7/8" wide recessed Buna-N gasket around the outlet, 3/4" corrosion resistant alloy bolts (per AWWA C-111, ANSI 21.11), a 3/4" forged steel test outlet and hydrostatic test pressure capability of 300 PSI in 12" and smaller outlet sizes. Flanged outlet shall be recessed per MSS-SP60. Tapping Sleeve shall be furnished with corrosion resistant shop coat paint primer.

Optional Epoxy Coated sleeves shall be furnished with a 3/4" stainless steel type 304 plug in the test outlet.

Tapping Sleeve for pipe sizes 36" and larger shall be of the heavy duty type with a body width of 4" wider than smaller sizes and integral strengthening of the outlet half to provide additional gasket sealing and pressure holding capability. Tapping Sleeves shall be JCM 412 or approved equal. Tapping sleeve shall be ANSI/NSF Standard 61, Annex G and ANSI/AWWA 372 Certified.

JCM 412 Fabricated Tapping Sleeve - Material Specifications

- BODY:** Carbon Steel per ASTM A-36, ASTM A-516 Grade 70 or equal.
- BOLTS:** Corrosion Resistant, high strength low alloy A242.
Optional Hardware: Stainless Steel 18-8 Type 304, 316; Electro Coated Hardware.
- FLANGE:** AWWA C207 Class D, ANSI 150lb. Drilling, recessed for tapping valve MSS-SP60.
Other flanges and outlet available upon request.
- GASKET:** Nitrile rubber compounded for use with water, salt solutions, mild acids and bases.
- FINISH:** Heavy coat of corrosion resistant shop coat primer. Optional Fusion Epoxy Coating (per ANSI/AWWA C-213) available.
- SERVICE RATING:** 4" to 12" Outlets: 175 PSI. Higher service rating available for specific applications and sizes.

JCM Industries Tapping Sleeves meet or exceed the ANSI/AWWA C-223 and MSS-SP 124 Standards as applicable.

Note: Large diameter sleeves incorporate multi-section design.

JCM 414 Fabricated Mechanical Joint Tapping Sleeve

This tapping sleeve combines the high strength and versatility of fabricated steel with the traditional side and end gasketed mechanical joint design. These sleeves are ideal for potential problem installations where strength, weight and beam load considerations are critical.

High Strength Steel - eliminates stress cracked casting or flange possibility.

True Mechanical Joint Design - industrial grade, fabricated steel body and heavyweight pusher glands prevent the warpage and distortion experienced by tapping sleeves using the split steel coupling design. JCM 114 meets design criteria in AWWA C110/ 111, ANSI 21.10/21.11 for tolerances, dimensions and configuration of the time proven mechanical joint seal.

Side And End Gaskets - provide complete seal around the pipe.

Fabricated Sleeves - provide more strength with significantly reduced weight than a cast sleeve. The lighter sleeve reduces the load on the pipe and aids in installation and handling.

Accommodates Non-Standard Pipe Characteristics - oversize, undersize or irregularities in the pipe O.D. can be accommodated within the fitting increasing performance and safety factor. The JCM 414 is available in larger sizes, non-standard sizes and with many special options (special flanges, special laying lengths, etc.)

Improved Availability - fabricated sleeves with non-standard sizes have a delivery schedule of three to five weeks, significantly less than a cast sleeve's six to nine months.

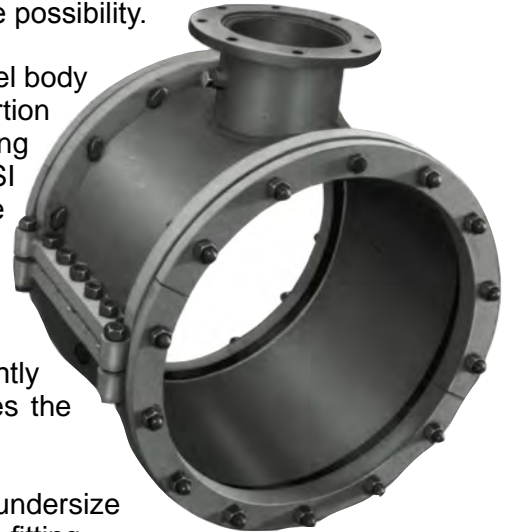

Typical Application:
Branching
Permanent

Valves
Line Branches
Internal Line Access
Large diameter, size on size taps
Taps on Pipe Susceptible to
Breakage
For application parameters, contact
JCM Technical and Engineered
Sales
800-527-8482 or 903-832-2581

HOW TO ORDER

For pricing and engineering, the following information must be furnished:

JCM 414 is available fabricated of 304 stainless steel or 316 stainless steel

Type of pipe
Outside diameter of pipe
Irregular or non-standard pipe characteristics
Line contents and pressure
Outlet Size (14" and larger, furnish manufacturer of valve and cutter size)
Coating
Special requirements

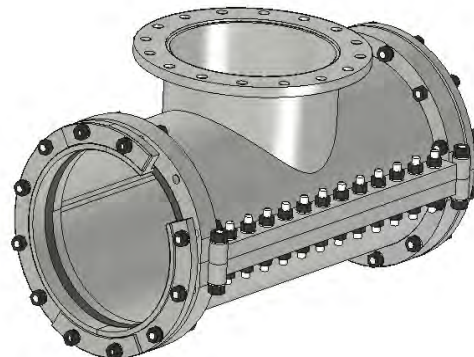

JCM 414 Fabricated Mechanical Joint Tapping Sleeve

The JCM 414 Fabricated Mechanical Joint Tapping Sleeve is recommended for taps on pipe that will not accommodate a direct outlet seal tapping sleeve. The 414 utilizes a true mechanical joint sleeve design that completely encompasses the tap area, eliminating any potential leaks due to pipe cracks or breaks. Side gaskets are internally and externally trapped in a recessed groove machined into the bolting lug bars that completely compress the gaskets creating the watertight seal on the sides of the sleeve. The end gaskets are compressed into the sleeve housing with mechanical joint end glands, providing the water tight seal on the ends of the sleeve and completing the full encapsulation of the tap area.

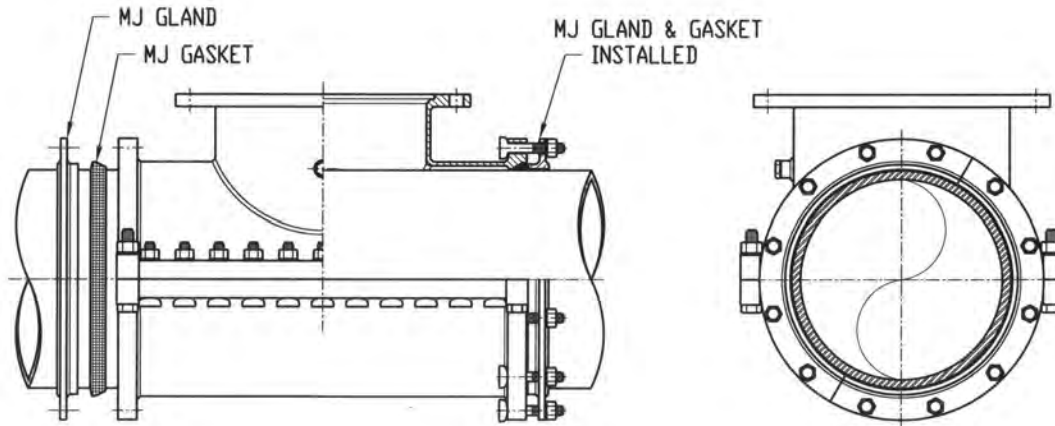

JCM 414 Fabricated Mechanical Joint Tapping Sleeve

JCM 414 Fabricated Mechanical Joint Tapping Sleeve - Typical Specification

Tapping Sleeve shall be of split mechanical joint design with separate end and side gaskets. The fitting shall be constructed of high strength steel, ASTM A-36, ASTM A-516 Grade 70 or equal. The mechanical joint end dimensions shall conform to AWWA Standard C-110/C-111. Split coupling designs are not acceptable. Tapping Sleeves shall be JCM 414 Mechanical Joint Tapping Sleeve or approved equal. Tapping sleeve shall be ANSI/NSF Standard 61, Annex G and ANSI/AWWA 372 Certified.

JCM 414 Fabricated Mechanical Joint Tapping Sleeve - Material Specification

- BODY:** Carbon Steel per ASTM A-36, ASTM A-516 Grade 70 or equal. Optional 304 or 316 Stainless Steel.
- FLANGE:** AWWA C207 Class D, ANSI 150 lb. Drilling, recessed for tapping valve MSS-SP60
Optional flanges available upon request.
- GLAND:** ASTM A-36 or Ductile Iron. Optional 304 or 316 Stainless Steel.
- BOLTS:** Corrosion Resistant, high strength low alloy A242.
Optional Hardware: Stainless Steel 18-8 Type 304, Stainless Steel 316, Electro Coated Hardware.
- STUDS:** B7 Material
- GASKET:** Nitrile rubber compounded for use with water, salt solutions, mild acids and bases.
Optional EPDM gaskets available.
- COATING:** Heavy coat of corrosion resistant shop coat primer, an excellent base for bitumastic coal tar or similar field coatings.
Optional Fusion Epoxy Coating (per ANSI/AWWA C-213) available.

JCM Industries Tapping Sleeves meet or exceed the ANSI/AWWA C-223 and MSS-SP 124 Standards as applicable.

JCM 415 Tapping Sleeve for Concrete Steel Cylinder Pipe

The JCM 415 Tapping Sleeve for Concrete Steel Cylinder Pipe is the standard in the industry for fast safe taps on Concrete Pressure Pipe. Designed to meet the AWWA M-9 Manual, the JCM 415 is the leading sleeve preferred by PCCP tapping contractors. These fabricated tapping sleeves are designed to reinforce the pipe and provide for easy installation with maximum safety factor. There are many unique features as well as options available on these sleeves. Unique to these sleeves are the following

Separate Body and Tapping Gland (outlet) - by separating the outlet gland from the sleeve body the sleeve reinforces the pipe prior to removal of the critical prestress wire from the outlet area.

Broad Cross Section Gasket - the 7/8" wide gasket with a hydromechanical lip provides a broad sealing surface which produces an initial seal that increases with increases in line pressure. The broad, flat gasket is very advantageous for sealing on beveled cylinder welds.

Gusseted Pressure Plate - the gusseted pressure plate eliminates problems caused by flexing of the cylinder or tapping sleeve pressure plate. This grooved plate is contoured to fit the cylinder and retains the broad profile gasket to provide an extra margin of safety at this critical point.



Combination Gland/Draw Flange - the combination gland/draw flange on 4" - 12" outlet sizes facilitates tapping with a 25" travel tapping machine. Larger outlets utilize separate flanges for each function to make bolt take-up on large flanges more accessible.

Load Bearing Set Screws - the JCM 415 Tapping Sleeve is furnished with load bearing set screws on the gland flange that are tightened after the gland is installed. These set screws tighten against the sleeve draw flange, transferring any load on the outlet away from the steel cylinder and onto the sleeve.

Grout Seal Assembly - Type I 415 Tapping Sleeve, the standard sleeve, is furnished with straps and a grout seal assembly under the sleeve. These two design features facilitate fitting oversize, undersize and out-of-round pipe by providing the means to pour cement grout into a cavity to make a perfect sleeve fit. This feature is in accordance with AWWA M-9 Manual as recommended by the manufacturers of concrete pressure pipe. Epoxy coated sleeves and sleeves with a solid back sit directly on the pipe, precluding the use of the grout seal assembly.

Epoxy Coated Waterway - the tapping sleeve's waterway is fusion applied epoxy coated to provide a quality connection protected against corrosion in the critical waterway

HOW TO ORDER

For pricing and engineering, the following information must be furnished:

- Type of pipe (also manufacturer and class if known)
- Type of sleeve
- Outside diameter of pipe and cylinder O.D.
- Line content and pressure
- Outlet size (on outlets 14" and larger furnish manufacturer of valve and cutter size)
- Any special requirements or options.

FOR SLEEVES FOR REINFORCED CONCRETE PIPE ASK FOR JCM 412 TAPPING SLEEVES FOR REINFORCED CONCRETE PIPE.



JCM 415 Tapping Sleeve for Concrete Steel Cylinder Pipe

Many agencies have special requirements which are modifications of our standard design. JCM's manufacturing flexibility makes it possible for us to offer a great many modifications without delay in product availability. Some of the more popular options on these sleeves are:

A solid back half in lieu of straps (Type II) for Pretension Concrete Cylinder Pipe.
 Entire sleeve and outlet epoxy coated with stainless steel straps.
 Different locations of the grouting holes.

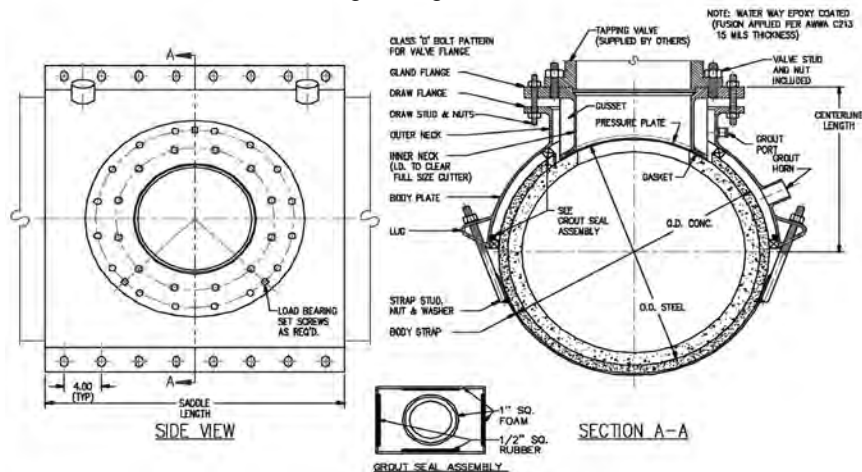

JCM 415 Tapping Sleeve for Concrete Steel Cylinder Pipe - Typical Specification

Tapping Sleeves for Concrete Steel Cylinder Pipe shall be in accordance with AWWA Manual M-9. They shall also meet AWWA C-301 and C-303 Standards pertaining to design, manufacturing quality tests and welders qualifications. Manufacturers shall have manufactured this type of tapping sleeve for a minimum of ten (10) years.

The sleeves shall have a separate gland which permits installation of the sleeve prior to the cutting of the prestress wires. The gland shall have a fusion epoxy coated (per AWWA C-213) waterway, and a minimum 7/8" wide hydromechanical gasket set in a retaining machined groove of a pressure plate. For outlet sizes 14" and larger, the gasket groove must be consistently positioned about throat of tapping waterway. Inside diameter of the gasket groove must be set back a minimum of 1" from the waterway to allow dispersal of forces generated by gasket compression. Gasket grooves machined in a circle and formed to an elliptical shape will not be an accepted equal. The pressure plate shall be gusseted to the draw flange to eliminate flexing. The gland shall be equipped with load bearing set screws to protect the cylinder. Sleeves shall be furnished with grouting seals and grout horns to facilitate filling the space between the sleeve and the pipe. Tapping Sleeves shall be JCM 415 Tapping Sleeve or approved equal. Tapping sleeves shall be ANSI/NSF Standard 61, Annex G and ANSI/AWWA 372 Certified.

JCM 415 Tapping Sleeve for Concrete Steel Cylinder Pipe - Material Specification

- BODY:** Carbon Steel per ASTM A-36, ASTM A-516 Grade 70 or equal.
- FLANGE:** Combination flange with ANSI 150 lb. Drilling, recessed for tapping valve MSS-SP60
- GASKET:** Compounded for use with water, salt solutions, mild acids, bases and sewage.
- BOLTS:** Corrosion resistant, high strength low alloy A242. DRAW HARDWARE: B7 Material
Optional Stainless Steel, 18-8 Type 304.
- FINISH:** Heavy coat of corrosion resistant shop coat primer on sleeve, gland and straps. Waterway of gland is epoxy coated (fusion applied per ANSI/AWWA C-213). Optional Fusion Epoxy Coating on entire sleeve.

JCM Industries Tapping Sleeves meet or exceed the ANSI/AWWA C-223 and MSS-SP 124 Standards as applicable. JCM Industries recommends a template of the outside diameter of the pipe surface on all taps with an outlet of 24" or larger, on all taps where the outlet is more than 60% of the pipe size, on pipe which out-of-roundness is suspected and on high-pressure taps where the fit of the sleeve is critical to the high pressure performance. Instructions for this procedure are available from JCM upon request.

JCM 452 All Stainless Steel Tapping Sleeve with Outlet Seal Gasket

The JCM 452 All Stainless Steel Tapping Sleeve incorporates the heavy duty design of the fabricated steel tapping sleeve with the corrosion resistance of all stainless steel. This heavy design utilizes a broad cross section, hydromechanical outlet gasket in lieu of the full body gasket. This outlet gasket provides a positive seal which increases with increase in line pressure. The JCM 452 has been engineered for installations requiring higher working pressure, higher safety factor or longer service life than standard all stainless or cast iron sleeves and manufactured to provide the superior corrosion resistance in applications on mains which are not subject to beam breaks.

Heavy all stainless tapping sleeves offer extra benefits.

All Stainless Construction - all stainless steel construction provides extra corrosion resistance. The stainless steel flange, outlet and body join as one unit of similar metals to assure the highest structural strength and long term corrosion resistance.

Heavy Duty Design - heavier construction and thicker metal provide extra reinforcement of the pipe and outlet. The extra bolting power and body thickness eliminate problems inherent with light weight sleeves.

High Pressure Capability - High Safety Factor - the broad, heavy hydromechanical gasket provides for high working pressure applications. They are also ideal for critical problem prone taps such as pump and lift stations, large diameter mains and large outlets.

Large Sizes - High Pressure - the premier sleeve for larger sizes of ductile iron, PVC, PE and steel pipe. High pressure sleeves are available on request.

Stronger - Yet Lighter Than Cast Sleeves - reduced weight aids in installation and handling as well as reducing load on the pipe.

Extra Wide for Support and Stability - extra width and heavier neck and body material provide extra reinforcement of the outlet and extra stability during the tapping process.

Affordable - these all stainless sleeves are surprisingly affordable in all sizes. Larger sleeves are priced less than ductile iron mechanical joint sleeves which offer less corrosion resistance and pressure capability.

For all 316 Stainless Steel Construction, specify JCM 6452 All 316 Stainless Steel Tapping Sleeve with Outlet Seal Gasket.

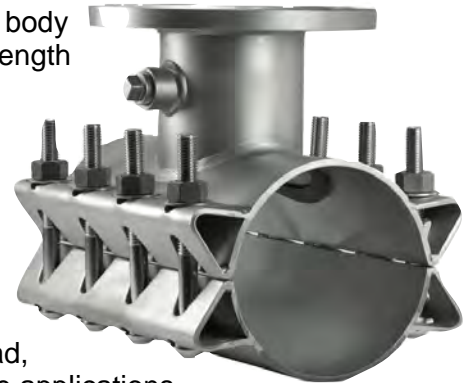

Typical Application:
Branching
Permanent

Valves
Line Branches
Internal Line Access

For application parameters, contact
JCM Technical and Engineered
Sales
800-527-8482 or 903-832-2581



JCM 452 All Stainless Steel Tapping Sleeve with Outlet Seal Gasket

The JCM 452 All Stainless steel Tapping Sleeve is especially recommended for applications involving large diameters, high working pressures and fluctuating line pressures in corrosive or acidic environments. Direct compression of the gasket provides maximum sealing capability for high or fluctuating pressures.

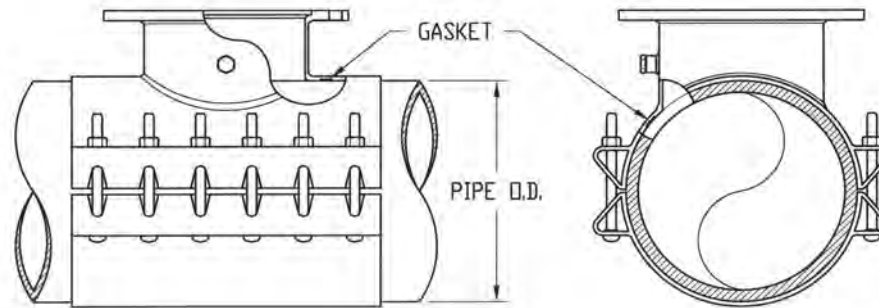

JCM 452 All Stainless Steel Tapping Sleeve

HOW TO ORDER

For pricing and engineering, the following information must be furnished:

| | |
|--|--|
| Type of pipe | Outside diameter of pipe |
| Irregular or non-standard pipe characteristics | Line contents |
| Outlet size | Working and Test Pressure requirements |

JCM 452 All Stainless Steel Tapping Sleeve - Typical Specification

Tapping Sleeve shall be of the high pressure type having a wide body, made of corrosion resistant 304 stainless steel, which conforms to and reinforces the pipe. The sleeves shall have a Buna-N gasket with a hydromechanical activated lip captured in a recessed groove around the outlet, replaceable stainless steel bolts (18-8 type 304) nuts and washers. Stainless tapping sleeve shall be furnished with a 3/4" stainless steel test plug in the test outlet. Flanged outlets shall be recessed per MSS-SP60 to accept tapping valve. Tapping Sleeve shall be JCM 452 or approved equal. Tapping sleeve shall be ANSI/NSF Standard 61, Annex G and ANSI/AWWA 372 Certified.

JCM 452 All Stainless Steel Tapping Sleeve - Material Specification

- BODY:** Stainless Steel 18-8 Type 304. Optional 316 Stainless Steel.
- BOLTS:** Stainless Steel 18-8 Type 304. Optional 316 Stainless Steel.
- FLANGE:** CF8 cast stainless steel (equal to 304) or equivalent 304 forged stainless steel flange per ANSI/AWWA Standard C-228 Class SD flange. Flanged outlets shall be recessed per MSSSP60 to accept tapping valve. Optional 316 Stainless Steel.
- GASKET:** Nitrile rubber compounded for use with water, salt solutions, mild acids and bases.
- SERVICE RATING:** 4" - 12" Outlets: Class SD 150 PSI. Service rating of 250 PSI and higher available with specified flange.

JCM Industries Tapping Sleeves meet or exceed the ANSI/AWWA C-223 and MSS-SP 124 Standards as applicable.

Note: Large diameter sleeves incorporate multi-section design.

JCM 440 Line Stop Fittings

Take a Look!!!

JCM 440 FAMILY OF LINE STOP FITTINGS HAS EXPANDED

New Plug Configuration Option - New Numbering System

Whatever your application needs, JCM has it! JCM Industries offers **the largest selection** of sleeve options in the industry - including design, materials and plug configurations.

Options include:

- Plug Configuration - Threaded Plug or Push Plug/Pin Style
- All stainless steel construction for maximum corrosion resistance
- Stainless body construction with carbon steel outlets for economical applications
- Carbon steel construction
- Epoxy coated sleeve
- Epoxy coated bolts
- Full circumferential gasket for pipelines susceptible to breaking
- Outlet seal gasket for large diameter and high pressure ratings

The Number One Choice of Line Stopping Contractors

The **JCM 440 Line Stop Fitting** is a structural fitting, engineered to provide:

Heavy Duty Construction - increases reliability and safety factor, eliminating shifting and flexing during the critical plugging process that can cause future complications.

Test Plug Outlet - Allows for testing of all seals prior to tapping the pressurized line. This includes the sleeve to pipe seal and the completion plug seal.

Adapts To All Popular Line Stopping Machines - JCM 440 Line Stop Fittings will adapt to ANY manufacturer's plugging equipment, making the JCM 440 versatile and convenient to utilize.

Special engineered JCM Line Stop Fittings are available for sizes 14" and larger for various types of pipe. For information, contact JCM Engineered and Technical Sales Team.

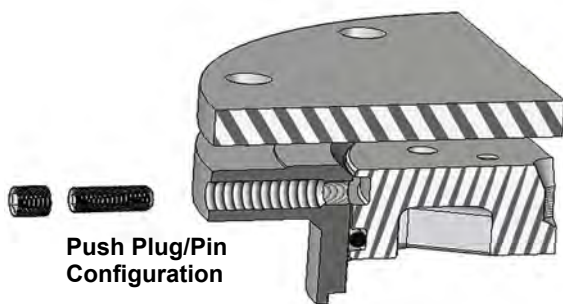

Push Plug/Pin Configuration

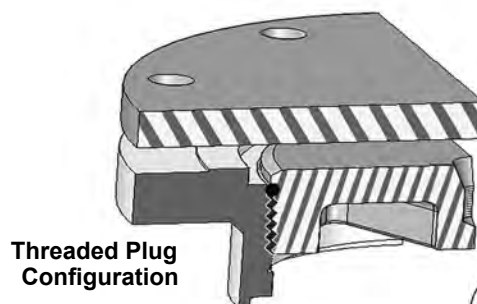

Threaded Plug Configuration



JCM Line Stop Fittings with Full Circumferential Gasket

The 440 Line Stop Sleeve Family offers the sleeve you need for the application. As the **NUMBER ONE** choice of contractors, JCM continues to meet the challenge of field application requirements with product design, material selection and delivery expectations.

JCM 440 Line Stop Family continues to grow with advanced designs, material combinations and numerous options to fit your application.



JCM's patented Line Stop Sleeves adapt to popular line stop machines and can be rated up to 250 PSI.

JCM Line Stop Sleeves with Full Circumferential Gasket are designed for applications in which the pipe is susceptible to breaking during or after the tapping/line stop procedure. JCM 440 Line Stops with Full Circumferential Gasket are offered in two fabricated material combinations: All Stainless Steel or Stainless Steel with Carbon Steel Outlet.

Both sleeves are offered with either the "threaded plug" design or the "push plug" design.

JCM 440 Line Stop Sleeves with Full Circumferential Gasket Material Specifications

| | |
|--------------------------------|---|
| Line Stop Plug: | Ductile Iron per ASTM A536 |
| Plug O-Ring: | Nitrile (NBR, Buna-N) Rubber - Gasket temperature range -40° to 180°F (-40°C to 82°C). |
| Blind Flange: | 150#, ASTM A36 Carbon Steel, Epoxy Coated |
| Blind Flange Gasket: | Styrene-Butadiene Rubber (SBR) - Compounded for use with water, salt solutions, mild acids and bases. Standard temperature range from -40° to 150°F (-40° to 65°C) constant, maximum intermittent 180°F (82°C). |
| Push Plug/Pin Hardware: | SAE Grade 8 |
| Bolts: | Stainless Steel 18-8 Type 304 |
| Body: | Stainless Steel 18-8 Type 304 |
| Body Gasket: | Full circumferential virgin Styrene-Butadiene Rubber (SBR) - Compounded for use with water, salt solutions, mild acids and bases. Per ASTM D-2000 M4AA 607. Standard temperature range from -40° to 150°F (-40° to 65°C) constant, maximum intermittent 180°F (82°C). |

| 440 Line Stop Sleeve | Outlet Material Options for Stainless Steel Full Circumferential Gasket Sleeve |
|---|---|
|  | <p>JCM 440 Type 1 - All Stainless Steel with Full Circumferential Gasket - Threaded Plug JCM 440 Type 11 - All Stainless Steel with Full Circumferential Gasket - Push Plug/Pin</p> <p>Outlet Material: ASME/ANSI 150 lb. Drilling, B16.1 Class 125 Compatible, Type 304 Stainless Steel</p> |
|  | <p>JCM 440 Type 4 - Stainless Steel Carbon Steel Outlet Full Circumferential Gasket - Threaded Plug JCM 440 Type 14 - Stainless Steel Carbon Steel Outlet Full Circumferential Gasket - Push Plug/Pin</p> <p>Outlet Material: ASME/ANSI 150 lb. Drilling, B16.1 Class 125 Compatible, Carbon Steel, coated for corrosion resistance. Optional: Fusion applied epoxy coating.</p> |

1. Determine O.D. of pipe
 2. Select proper sleeve number
 3. Select proper outlet size
 4. Select proper outlet plug type code (threaded or push/pin)
 5. Add Outlet Type Code (T1 or T11)
- Example: For Ductile Iron with 6.90 O.D. by 6" outlet, with threaded plug, order: 440-0690X6T2

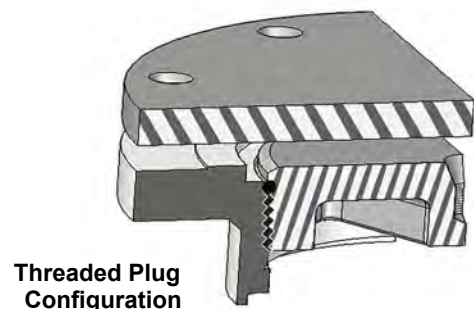
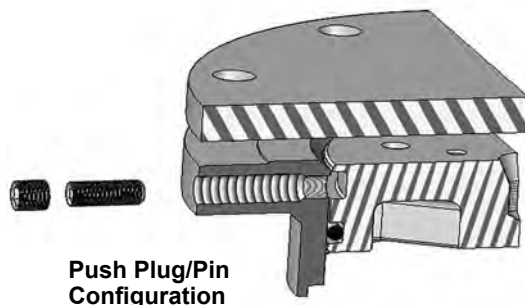



JCM 440 Type 1 Line Stop with Full Circumferential Gasket - Threaded Plug
JCM 440 Type 11 Line Stop with Full Circumferential Gasket - Push Plug/Pin
All Stainless Steel Construction - Full Circumferential Gasket

Recommended for: cast iron, ductile iron, asbestos cement, PVC and other types of pipe susceptible to breakage.

| NOMINAL PIPE SIZE (IN.) | SLEEVE O.D. RANGE (IN.) | SLEEVE NUMBER X OUTLET SIZE X PLUG CODE | OUTLET SIZE | THREADED PLUG TYPE CODE | PUSH PLUG/PIN TYPE CODE | APPROX. WEIGHT (LBS.) |
|-------------------------|-------------------------|---|-------------|-------------------------|-------------------------|-----------------------|
| 4 | 4.40 - 4.60 | 440-0450 | x 4 | T1 | T11 | 56 |
| | 4.50 - 4.80 | 440-0465 | | T1 | T11 | |
| | 4.74 - 5.00 | 440-0480 | | T1 | T11 | |
| | 5.10 - 5.30 | 440-0520 | | T1 | T11 | |
| 6 | 6.56 - 6.76 | 440-0663 | x 4 | T1 | T11 | 63 81 |
| | 6.84 - 7.10 | 440-0690 | | T1 | T11 | |
| | 7.05 - 7.25 | 440-0720 | x 6 | T1 | T11 | |
| | 7.40 - 7.65 | 440-0745 | | T1 | T11 | |
| 8 | 8.54 - 8.74 | 440-0863 | x 6 | T1 | T11 | 86 132 |
| | 8.60 - 9.05 | 440-0900 | | T1 | T11 | |
| | 8.98 - 9.30 | 440-0905 | x 8 | T1 | T11 | |
| | 9.27 - 9.50 | 440-0940 | | T1 | T11 | |
| 10 | 9.83 - 10.25 | 440-1000 | x 8 x10 | T1 | T11 | 126 192 |
| | 10.64 - 10.86 | 440-1075 | | T1 | T11 | |
| | 11.03 - 11.40 | 440-1110 | | T1 | T11 | |
| | 11.36 - 11.80 | 440-1140 | | T1 | T11 | |
| | 11.85 - 12.15 | 440-1200 | | T1 | T11 | |
| 12 | 12.62 - 12.85 | 440-1275 | x 8 x 12 | T1 | T11 | 144 269 |
| | 12.75 - 13.20 | 440-1300 | | T1 | T11 | |
| | 13.12 - 13.50 | 440-1320 | | T1 | T11 | |
| | 13.70 - 14.09 | 440-1392 | | T1 | T11 | |
| | 14.10 - 14.35 | 440-1420 | | T1 | T11 | |



JCM 440 Type 4 Line Stop Full Circumferential Gasket - Threaded Plug
JCM 440 Type 14 Line Stop Full Circumferential Gasket - Push Plug/Pin
Stainless Steel Body - Carbon Steel Outlet - Full Circumferential Gasket



Recommended for: cast iron, ductile iron, asbestos cement, PVC and other types of pipe susceptible to breakage.

| NOMINAL PIPE SIZE (IN.) | SLEEVE O.D. RANGE (IN.) | SLEEVE NUMBER X OUTLET SIZE X PLUG CODE | OUTLET SIZE | THREADED PLUG TYPE CODE | PUSH PLUG/PIN TYPE CODE | APPROX. WEIGHT (LBS.) |
|-------------------------|-------------------------|---|-------------|-------------------------|-------------------------|-----------------------|
| 4 | 4.40 - 4.60 | 440-0450 | x 4 | T4 | T14 | 56 |
| | 4.50 - 4.80 | 440-0465 | | T4 | T14 | |
| | 4.74 - 5.00 | 440-0480 | | T4 | T14 | |
| | 5.10 - 5.30 | 440-0520 | | T4 | T14 | |
| 6 | 6.56 - 6.76 | 440-0663 | x 4 | T4 | T14 | 63 81 |
| | 6.84 - 7.10 | 440-0690 | | T4 | T14 | |
| | 7.05 - 7.25 | 440-0720 | x 6 | T4 | T14 | |
| | 7.40 - 7.65 | 440-0745 | | T4 | T14 | |
| 8 | 8.54 - 8.74 | 440-0863 | x 6 | T4 | T14 | 86 132 |
| | 8.60 - 9.05 | 440-0900 | | T4 | T14 | |
| | 8.98 - 9.30 | 440-0905 | x 8 | T4 | T14 | |
| | 9.27 - 9.50 | 440-0940 | | T4 | T14 | |
| 10 | 9.83 - 10.25 | 440-1000 | x 8 x 10 | T4 | T14 | 126 192 |
| | 10.64 - 10.86 | 440-1075 | | T4 | T14 | |
| | 11.03 - 11.40 | 440-1110 | | T4 | T14 | |
| | 11.36 - 11.80 | 440-1140 | | T4 | T14 | |
| | 11.85 - 12.15 | 440-1200 | | T4 | T14 | |
| 12 | 12.62 - 12.85 | 440-1275 | x 8 x 12 | T4 | T14 | 144 269 |
| | 12.75 - 13.20 | 440-1300 | | T4 | T14 | |
| | 13.12 - 13.50 | 440-1320 | | T4 | T14 | |
| | 13.70 - 14.09 | 440-1392 | | T4 | T14 | |
| | 14.10 - 14.35 | 440-1420 | | T4 | T14 | |

Other sleeve ranges and outlet sizes available upon request.

JCM Line Stop Fittings with Outlet Seal Gasket

The JCM 440 Line Stop Fitting with Outlet Seal Gasket are fabricated for types of pipe that are not susceptible to breaking and for large diameter pipelines. JCM offers the broadest selection of material combination in the industry and can meet the exacting standards of your application. Fabrication materials include: carbon steel, carbon/stainless and all stainless steel. JCM patented Line Stop Sleeves adapt to popular line stop machines and can be rated up to 250 PSI. Other designs available: weld-on outlets and sleeves, mechanical joint sleeves, specialty configurations. All combinations are available with “threaded plug” design or “push plug” design.

| 440 Line Stop Sleeve | Outlet Gasket Sleeve Description |
|--|--|
|  | <p>JCM 440 Type 2 - Carbon Steel Construction - Outlet Seal Gasket - Threaded Plug JCM 440 Type 12 - Carbon Steel Construction - Outlet Seal Gasket - Push Plug/pin Pipe Sizes: 4" - 20" and larger Optional epoxy coating per ANSI/AWWA Standard C213 Optional Hardware 304 or 316 stainless Optional gasket materials. Recommended for: cast iron, ductile iron, C-900/C905 PVC, HDPE, steel</p> |
|  | <p>JCM 440 Type 3 - All Stainless Steel Construction - Outlet Seal Gasket - Threaded Plug JCM 440 Type 13 - All Stainless Steel Construction - Outlet Seal Gasket - Push Plug Pin Pipe Sizes: 4" - 20" and larger Optional gasket materials Recommended for: cast iron, ductile iron, C-900/C905 PVC, HDPE, steel</p> |
|  | <p>JCM 440 Type 5 - Stainless Steel Body - Carbon Steel Outlet - Outlet Seal Gasket - Threaded Plug JCM 440 Type 15 - Stainless Steel Body - Carbon Steel Outlet - Outlet Seal Gasket - Push Plug Pin Pipe Sizes: 4" - 20" and larger Optional gasket materials Recommended for: cast iron, ductile iron, C-900/C905 PVC, HDPE, steel</p> |

How To Order:

1. Determine O.D. of pipe
2. Select proper sleeve number
3. Select proper outlet size
4. Select proper outlet plug type code (threaded or push/pin)
5. Add Outlet Type Code (T2 or T12)

Example: For Ductile Iron with 6.90 O.D. by 6" outlet, with threaded plug, order: 440-0690X6T2

Other sleeve size and outlet size combinations available upon request.

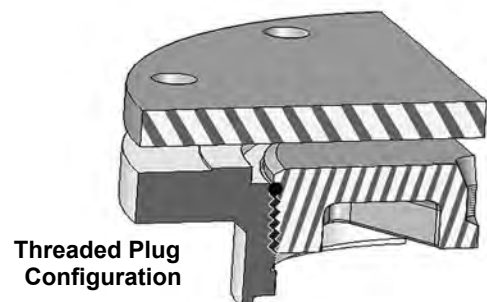
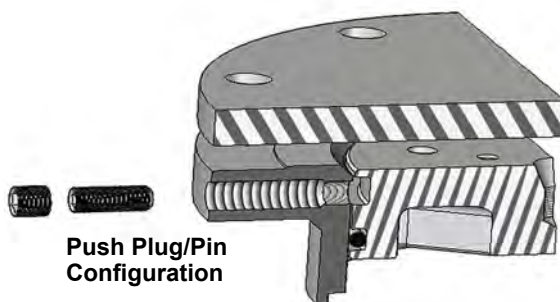

JCM 440 Type 2 - Carbon Steel - Outlet Seal Gasket - Threaded Plug
JCM 440 Type 12 - Carbon Steel - Outlet Seal Gasket - Push Plug/Pin

Furnished standard shopcoat with alloy hardware



- Line Stop Plug:** Ductile Iron per ASTM A536
- Plug O-Ring:** Nitrile (NBR, Buna-N) Rubber - Gasket temperature range -40° to 180°F (-40°C to 82°C).
- Blind Flange:** 150#, ASTM A36 Carbon Steel, Epoxy Coated
- Blind Flange Gasket:** Styrene-Butadiene Rubber (SBR) - for use with water, salt solutions, mild acids and bases. Standard temperature range from -40° to 150°F (-40° to 65°C) constant, maximum intermittent 180°F (82°C).
- Push Plug/Pins:** SAE Grade 8
- Outlet Gasket:** Nitrile Butadiene Rubber (NBR, Buna-N) per ASTM D2000. Molded virgin rubber with a external retention. Gasket temperature range -40° to 180°F (-40° - 82°C). Gasket suitable for water, salt solutions, mild acids, bases, and sewage.
- Body:** ASTM A285 Grade C or A36 Carbon Steel or Equal
- Flange:** ASME/ANSI 150 lb. Drilling, B16.1 Class 125 Compatible, Carbon Steel
- Bolts:** ASTM A242 corrosion resistant high strength, low alloy (per ANSI 21.11/AWWA C-111). Optional Stainless Steel 18-8 Type 304 or 316 available.

JCM 440 Type 2 - Carbon Steel - Outlet Seal Gasket - Threaded Plug
JCM 440 Type 12 - Carbon Steel - Outlet Seal Gasket - Push Plug/Pin

| NOMINAL PIPE SIZE (IN.) | SLEEVE O.D. RANGE (IN.) | SLEEVE NUMBER X OUTLET SIZE X PLUG CODE | OUTLET SIZE | THREADED PLUG TYPE CODE | PUSH PLUG/PIN TYPE CODE | APPROX. WEIGHT (LBS.) |
|-------------------------|-------------------------|---|-------------|-------------------------|-------------------------|-----------------------|
| 4 | 4.50 | 440-0450 | x 4 | T2 | T12 | 48 |
| | 4.80 | 440-0480 | | T2 | T12 | |
| | 5.20 | 440-0520 | | T2 | T12 | |
| | 5.56 | 440-0556 | | T2 | T12 | |
| 6 | 6.63 | 440-0663 | x 4 | T2 | T12 | 92 114 |
| | 6.84 - 7.10 | 440-0690 | | T2 | T12 | |
| | 7.05 - 7.25 | 440-0720 | x 6 | T2 | T12 | |
| | 7.40 - 7.65 | 440-0745 | | T2 | T12 | |
| 8 | 8.63 | 440-0863 | x 6 | T2 | T12 | 120 172 |
| | 8.98 - 9.30 | 440-0905 | | T2 | T12 | |
| | 9.27 - 9.50 | 440-0940 | x 8 | T2 | T12 | |
| | 9.83 - 10.25 | 440-1000 | | T2 | T12 | |
| 10 | 10.64 - 10.86 | 440-1075 | x 8 | T2 | T12 | 179 267 |
| | 11.03 - 11.40 | 440-1110 | | T2 | T12 | |
| | 11.36 - 11.80 | 440-1140 | x 10 | T2 | T12 | |
| | 11.85 - 12.15 | 440-1200 | | T2 | T12 | |
| 12 | 12.62 - 12.85 | 440-1275 | x 8 | T2 | T12 | 194 324 |
| | 13.12 - 13.50 | 440-1320 | | T2 | T12 | |
| | 13.70 - 14.09 | 440-1392 | x 12 | T2 | T12 | |
| | 14.10 - 14.35 | 440-1420 | | T2 | T12 | |
| 14 | 14.59 - 15.08 | 440-1475 | x 12 | T2 | T12 | 328 |
| | 15.23 - 15.80 | 440-1530 | | T2 | T12 | |
| | 15.73 - 16.22 | 440-1600 | | T2 | T12 | |
| | 16.30 - 16.73 | 440-1650 | | T2 | T12 | |
| 16 | 16.74 - 17.26 | 440-1684 | x 12 | T2 | T12 | 338 |
| | 17.33 - 17.87 | 440-1740 | | T2 | T12 | |
| | 17.88 - 18.43 | 440-1800 | | T2 | T12 | |
| | 18.62 - 19.19 | 440-1875 | | T2 | T12 | |
| 18 | 18.87 - 19.45 | 440-1920 | x 12 | T2 | T12 | 353 |
| | 19.41 - 20.01 | 440-1950 | | T2 | T12 | |
| | 20.00 - 20.60 | 440-2000 | | T2 | T12 | |
| | 20.29 - 20.94 | 440-2050 | | T2 | T12 | |
| | 20.93 - 21.57 | 440-2130 | | T2 | T12 | |
| 20 | 21.51 - 22.15 | 440-2160 | x 12 | T2 | T12 | 363 |
| | 22.16 - 22.81 | 440-2254 | | T2 | T12 | |
| | 22.78 - 23.45 | 440-2294 | | T2 | T12 | |
| | 23.46 - 24.16 | 440-2400 | | T2 | T12 | |
| | 24.15 - 24.85 | 440-2450 | | T2 | T12 | |
| | 24.82 - 25.52 | 440-2502 | | T2 | T12 | |

Other sleeve ranges and outlet sizes available upon request.

**JCM 440 Type 3 - All Stainless Steel - Outlet Seal Gasket - Threaded Plug
JCM 440 Type 13 - All Stainless Steel - Outlet Seal Gasket - Push Plug/Pin**



- Line Stop Plug:** Ductile Iron per ASTM A536
- Plug O-Ring:** Nitrile (NBR, Buna-N) Rubber - Gasket temperature range -40° to 180°F (-40°C to 82°C).
- Blind Flange:** 150#, ASTM A36 Carbon Steel, Epoxy Coated
- Blind Flange Gasket:** Styrene-Butadiene Rubber (SBR) - for use with water, salt solutions, mild acids and bases. Standard temperature range from -40° to 150°F (-40° to 65°C) constant, maximum intermittent 180°F (82°C).
- Push Plug/Pins:** SAE Grade 8
- Outlet Gasket:** Nitrile Butadiene Rubber (NBR, Buna-N) per ASTM D2000. Molded virgin rubber with a pressure activated hydromechanical design. Gasket is bonded into a cavity for internal and external retention. Gasket temperature range -40° to 180°F (-40° - 82°C). Gasket suitable for water, salt solutions, mild acids, bases, and sewage.
- Body:** Stainless Steel 18-8 Type 304
- Flange:** ASME/ANSI 150 lb. Drilling, B16.1 Class 125 Compatible, Type 304 Stainless Steel,
- Bolts:** Stainless Steel 18-8 Type 304.

**JCM 440 Type 3 - All Stainless Steel - Outlet Seal Gasket - Threaded Plug
JCM 440 Type 13 - All Stainless Steel - Outlet Seal Gasket - Push Plug/Pin**

| NOMINAL PIPE SIZE (IN.) | SLEEVE O.D. RANGE (IN.) | SLEEVE NUMBER X OUTLET SIZE X PLUG CODE | OUTLET SIZE | THREADED PLUG TYPE CODE | PUSH PLUG/PIN TYPE CODE | APPROX. WEIGHT (LBS.) |
|-------------------------|-------------------------|---|-------------|-------------------------|-------------------------|-----------------------|
| 4 | 4.50 | 440-0450 | x 4 | T3 | T13 | 48 |
| | 4.80 | 440-0480 | | T3 | T13 | |
| | 5.20 | 440-0520 | | T3 | T13 | |
| | 5.56 | 440-0556 | | T3 | T13 | |
| 6 | 6.63 | 440-0663 | x 4 | T3 | T13 | 92 114 |
| | 6.84 - 7.10 | 440-0690 | | T3 | T13 | |
| | 7.05 - 7.25 | 440-0720 | x 6 | T3 | T13 | |
| | 7.40 - 7.65 | 440-0745 | | T3 | T13 | |
| 8 | 8.63 | 440-0863 | x 6 x 8 | T3 | T13 | 120 172 |
| | 8.98 - 9.30 | 440-0905 | | T3 | T13 | |
| | 9.27 - 9.50 | 440-0940 | | T3 | T13 | |
| | 9.83 - 10.25 | 440-1000 | | T3 | T13 | |
| 10 | 10.64 - 10.86 | 440-1075 | x 8 x 10 | T3 | T13 | 179 267 |
| | 11.03 - 11.40 | 440-1110 | | T3 | T13 | |
| | 11.36 - 11.80 | 440-1140 | | T3 | T13 | |
| | 11.85 - 12.15 | 440-1200 | | T3 | T13 | |
| 12 | 12.62 - 12.85 | 440-1275 | x 8 x 12 | T3 | T13 | 194 324 |
| | 13.12 - 13.50 | 440-1320 | | T3 | T13 | |
| | 13.70 - 14.09 | 440-1392 | | T3 | T13 | |
| | 14.10 - 14.35 | 440-1420 | | T3 | T13 | |
| 14 | 14.59 - 15.08 | 440-1475 | x 12 | T3 | T13 | 328 |
| | 15.23 - 15.80 | 440-1530 | | T3 | T13 | |
| | 15.73 - 16.22 | 440-1600 | | T3 | T13 | |
| | 16.30 - 16.73 | 440-1650 | | T3 | T13 | |
| 16 | 16.74 - 17.26 | 440-1684 | x 12 | T3 | T13 | 338 |
| | 17.33 - 17.87 | 440-1740 | | T3 | T13 | |
| | 17.88 - 18.43 | 440-1800 | | T3 | T13 | |
| | 18.62 - 19.19 | 440-1875 | | T3 | T13 | |
| 18 | 18.87 - 19.45 | 440-1920 | x 12 | T3 | T13 | 353 |
| | 19.41 - 20.01 | 440-1950 | | T3 | T13 | |
| | 20.00 - 20.60 | 440-2000 | | T3 | T13 | |
| | 20.29 - 20.94 | 440-2050 | | T3 | T13 | |
| | 20.93 - 21.57 | 440-2130 | | T3 | T13 | |
| 20 | 21.51 - 22.15 | 440-2160 | x 12 | T3 | T13 | 363 |
| | 22.16 - 22.81 | 440-2254 | | T3 | T13 | |
| | 22.78 - 23.45 | 440-2294 | | T3 | T13 | |
| | 23.46 - 24.16 | 440-2400 | | T3 | T13 | |
| | 24.15 - 24.85 | 440-2450 | | T3 | T13 | |
| | 24.82 - 25.52 | 440-2502 | | T3 | T13 | |

Other sleeve ranges and outlet sizes available upon request.

JCM 440 Type 5 - Stainless Body - Carbon Steel Outlet - Outlet Seal Gasket - Threaded Plug
JCM 440 Type 15 - Stainless Body - Carbon Steel Outlet - Outlet Seal Gasket - Push Plug/Pin



- Line Stop Plug:** Ductile Iron per ASTM A536
- Plug O-Ring:** Nitrile (NBR, Buna-N) Rubber - Gasket temperature range -40° to 180°F (-40°C to 82°C).
- Blind Flange:** 150#, ASTM A36 Carbon Steel, Epoxy Coated
- Blind Flange Gasket:** Styrene-Butadiene Rubber (SBR) - for use with water, salt solutions, mild acids and bases. Standard temperature range from -40° to 150°F (-40° to 65°C) constant, maximum intermittent 180°F (82°C).
- Push Plug/Pins:** SAE Grade 8
- Outlet Gasket:** Nitrile Butadiene Rubber (NBR, Buna-N) per ASTM D2000. Molded virgin rubber with a pressure activated hydromechanical design. Gasket is bonded into a cavity for internal and external retention. Gasket temperature range -40° to 180°F (-40° - 82° C). Gasket suitable for water, salt solutions, mild acids, bases, and sewage.
- Body:** Stainless Steel 18-8 Type 304
- Flange:** ASME/ANSI 150 lb. Drilling, B16.1 Class 125 Compatible, Carbon Steel, coated for corrosion resistance. Optional: Fusion applied epoxy coating.
- Bolts:** Stainless Steel 18-8 Type 304.

JCM 440 Type 5 - Stainless Body - Carbon Steel Outlet - Outlet Seal Gasket - Threaded Plug
JCM 440 Type 15 - Stainless Body - Carbon Steel Outlet - Outlet Seal Gasket - Push Plug/Pin

| NOMINAL PIPE SIZE (IN.) | SLEEVE O.D. RANGE (IN.) | SLEEVE NUMBER X OUTLET SIZE X PLUG CODE | OUTLET SIZE | THREADED PLUG TYPE CODE | PUSH PLUG/PIN TYPE CODE | APPROX. WEIGHT (LBS.) |
|-------------------------|-------------------------|---|-------------|-------------------------|-------------------------|-----------------------|
| 4 | 4.50 | 440-0450 | x 4 | T5 | T15 | 48 |
| | 4.80 | 440-0480 | | T5 | T15 | |
| | 5.20 | 440-0520 | | T5 | T15 | |
| | 5.56 | 440-0556 | | T5 | T15 | |
| 6 | 6.63 | 440-0663 | x 4 | T5 | T15 | 92 114 |
| | 6.84 - 7.10 | 440-0690 | | T5 | T15 | |
| | 7.05 - 7.25 | 440-0720 | x 6 | T5 | T15 | |
| | 7.40 - 7.65 | 440-0745 | | T5 | T15 | |
| 8 | 8.63 | 440-0863 | x 6 | T5 | T15 | 120 172 |
| | 8.98 - 9.30 | 440-0905 | | T5 | T15 | |
| | 9.27 - 9.50 | 440-0940 | x 8 | T5 | T15 | |
| | 9.83 - 10.25 | 440-1000 | | T5 | T15 | |
| 10 | 10.64 - 10.86 | 440-1075 | x 8 | T5 | T15 | 179 267 |
| | 11.03 - 11.40 | 440-1110 | | T5 | T15 | |
| | 11.36 - 11.80 | 440-1140 | x 10 | T5 | T15 | |
| | 11.85 - 12.15 | 440-1200 | | T5 | T15 | |
| 12 | 12.62 - 12.85 | 440-1275 | x 8 | T5 | T15 | 194 324 |
| | 13.12 - 13.50 | 440-1320 | | T5 | T15 | |
| | 13.70 - 14.09 | 440-1392 | x 12 | T5 | T15 | |
| | 14.10 - 14.35 | 440-1420 | | T5 | T15 | |
| 14 | 14.59 - 15.08 | 440-1475 | x 12 | T5 | T15 | 328 |
| | 15.23 - 15.80 | 440-1530 | | T5 | T15 | |
| | 15.73 - 16.22 | 440-1600 | | T5 | T15 | |
| | 16.30 - 16.73 | 440-1650 | | T5 | T15 | |
| 16 | 16.74 - 17.26 | 440-1684 | x 12 | T5 | T15 | 338 |
| | 17.33 - 17.87 | 440-1740 | | T5 | T15 | |
| | 17.88 - 18.43 | 440-1800 | | T5 | T15 | |
| | 18.62 - 19.19 | 440-1875 | | T5 | T15 | |
| 18 | 18.87 - 19.45 | 440-1920 | x 12 | T5 | T15 | 353 |
| | 19.41 - 20.01 | 440-1950 | | T5 | T15 | |
| | 20.00 - 20.60 | 440-2000 | | T5 | T15 | |
| | 20.29 - 20.94 | 440-2050 | | T5 | T15 | |
| | 20.93 - 21.57 | 440-2130 | | T5 | T15 | |
| 20 | 21.51 - 22.15 | 440-2160 | x 12 | T5 | T15 | 363 |
| | 22.16 - 22.81 | 440-2254 | | T5 | T15 | |
| | 22.78 - 23.45 | 440-2294 | | T5 | T15 | |
| | 23.46 - 24.16 | 440-2400 | | T5 | T15 | |
| | 24.15 - 24.85 | 440-2450 | | T5 | T15 | |
| | 24.82 - 25.52 | 440-2502 | | T5 | T15 | |

Other sleeve ranges and outlet sizes available upon request.

JCM Fabricated Weld On Line Stop Outlets

Carbon Steel and All Stainless Steel (304 & 316) Construction Available

Outlets, partial sleeves and full sleeves readily available for steel pipe 4" and larger. Size on size and reducing outlets to accommodate folding head or bag stop machinery available. Outlets and partial sleeves available for tank and bulkhead use.

JCM 440 Type 6 - Full Body- Threaded Plug
JCM 440 Type 16 - Full Body - Push Plug/Pin
JCM 440 Type 7 - Outlet Only - Threaded Plug
JCM 440 Type 17 - Outlet Only - Push Plug/Pin



| Nominal Pipe Size (IN.) | Sleeve Number | Outlet Sizes | SLEEVE STYLE THREADED PLUG TYPE CODE | SLEEVE STYLE PUSH PLUG/PIN TYPE CODE | SLEEVE STYLE THREADED PLUG TYPE CODE | SLEEVE STYLE PUSH PLUG/PIN TYPE CODE |
|-------------------------|---------------|--------------|--------------------------------------|--------------------------------------|--------------------------------------|--------------------------------------|
| 4 | 440-0450 | x 4 | T6 | T16 | T7 | T17 |
| 6 | 440-0663 | x 4 x 6 | T6 T6 | T16 T16 | T7 T7 | T17 T17 |
| 8 | 440-0863 | x 6 x 8 | T6 T6 | T16 T16 | T7 T7 | T17 T17 |
| 10 | 440-1075 | x 8 x 10 | T6 T6 | T16 T16 | T7 T7 | T17 T17 |
| 12 | 440-1275 | x 8 x 12 | T6 T6 | T16 T16 | T7 T7 | T17 T17 |
| 14 | 440-1400 | x 12 | T6 | T16 | T7 | T17 |
| 16 | 440-1600 | x 12 | T6 | T16 | T7 | T17 |
| 18 | 440-1800 | x 12 | T6 | T16 | T7 | T17 |
| 20 | 440-2000 | x 12 | T6 | T16 | T7 | T17 |

How To Order:

1. Determine O.D. of pipe
2. Select proper sleeve number
3. Select proper outlet size
4. Select proper sleeve style and outlet plug type code (threaded or push/pin)
5. Add Outlet Type Code (T6 or T16)

Example: For Full Body Sleeve, Steel Pipe with 6.63 O.D., with 6" outlet, with threaded plug, order: 440-0663X6T6

JCM 440 Weld On Line Stop Fitting: test plug/outlet are furnished upon request, contact JCM.

Fittings are fabricated to exact O.D. of pipe.

Larger sizes available.

Other designs offered; contact JCM Industries.



JCM Weld On Tapping Outlets

Weld-on outlets & connections are dependable and economical with JCM Weld On Fittings. Outlets, partial sleeves and complete sleeves are readily available for steel pipe 6" and larger with size on size and reducing outlets. Outlets and partial sleeves are also available for tank and bulkhead use. Various configurations of this design are available. Featured below are the most popular.

Available fabricated of carbon steel, 304 Stainless Steel and 316 Stainless Steel



**416 Type 1:
Weld On Outlet**



**416 Type 2:
Split Tee
Three Piece Weld On Saddle**



**416 Type 3:
Flanged Nozzle
Weld On Outlet**



**416 Type 4:
Hat Flange Weld On
Outlet**

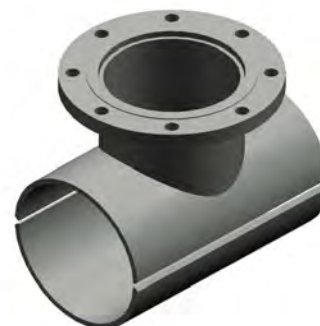

**417 Type 1:
Split Tee
Weld On Tapping Sleeve**

MATERIAL SPECIFICATIONS

BODY: ASTM A-36 Steel or equal.
Optional 304 or 316 Stainless Steel.

FINISH: Heavy coat of corrosion resistant shop coat primer.
Optional Fusion Epoxy Coating available.

FLANGE: AWWA C207 Class D, ANSI 150 lb. Drilling, recessed for tapping valve MSS-SP60.
Other Flanges Available Upon Request.
Tapping Sleeves shall be ANSI/NSF Standard 61, Annex G and ANSI/AWWA 372 Certified.

Other configurations
available upon
request.

HOW TO ORDER - JCM WELD ON OUTLETS

1. Determine pipe O.D. and outlet size. Each sleeve is fabricated to the exact O.D. of the pipe.
2. Determine sleeve type required.
For Standard Type 1 416 Weld On Outlet for steel pipe with 6.63 O.D. with 6" outlet, order: 416-0663 x 6 Type1.

Other configurations and designs available.

Standard outlet flange is AWWA C207 Class D, ANSI 150lb Drilling, recessed for tapping valve MSS-SP60. Other flanges available upon request.

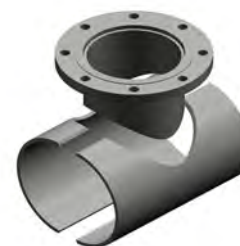

Custom Engineered Fittings Repair - Connection - Branching

Services for custom designed, specialty and emergency fabrication of fittings for the Repair, Connection or Tapping of pipelines is an everyday occurrence at JCM. To best serve the end user, the application information included in the data sheet below is critical to ensure the fastest response for quotation and product delivery. Once the application parameters are determined, generic product information can be provided with material specifications for submittal to agencies.

Engineered Fitting Data Submittal Sheet

Contact Name: _____

Contact Number/E-mail: _____

| Type of Application | Repair | Connection | Tapping |
|------------------------------------|--------------|-----------------|------------|
| Type of Pipe | | | |
| O.D. of Pipe | | | |
| SDR/Wall Thickness (if applicable) | | | |
| Max. Working Pressure | | | |
| Max. Test Pressure | | | |
| Line Content | | | |
| Line Content Temp. Max. | | | |
| Material of Construction | Carbon Steel | Stainless Steel | 304 or 316 |
| Carbon Construction Coating | Shopcoat | Epoxy Coat | Other |
| Carbon Construction Hardware | Alloy | Stainless Steel | 304 or 316 |
| Considerable Space Limitations | | | |

JCM Industries custom fabricates fittings for all types of unique applications. Fittings ranging from as small as 3" up through tank and bulkhead applications.

Additional Information to include for:

Repair

Type of Repair - break, split, leaking joint, pinhole, etc.
Size of Repair - width, length, approximate gap between pipe ends, type/size of leaking joint, joint configuration

Connection

O.D.s of both pipes to be joined
Flange type and size for flanged coupling adapters
Restraint requirements

Tapping/Branching

Size of outlet
Type of outlet - flanged, threaded, mechanical joint, beveled for welding, line stop

Submit information:

Phone: 800-527-8482 or 903-832-2581
Fax: 800-874-9524 or 903-838-6260
E-mail: sales@jcmindustries.com

JCM Fabricated Expansion Joints

JCM Expansion Joints permit up to 10" of concentrated pipe movement that provides for normal expansion/contraction of pipelines subject to variations of both environmental and line content temperatures. JCM Expansion Joints are manufactured using a telescoping design that consists of a fabricated steel body, or housing, that accommodates an inserted internal "slip pipe" that moves in and out of the body. This free movement absorbs the linear, or axial, movement of the section of pipe. The fabricated steel body houses a "packing" area of alternating rings of lubricated flax and rubber that provides the water tight seal during the cycling of the joint. JCM Expansion Joints offer several design options including end connections, coatings, limit rods, stainless steel fabrication and others. JCM Expansion Joints are manufactured for each specific application allowing for the incorporation of special options or engineered features required for the installation.

Heavy Duty Construction - the heavy duty, durable exterior body provides the protective shell for the slip pipe and packing system. For corrosive or acidic environments, the expansion joint may be epoxy coated or fabricated of stainless steel.

Externally Guided Slip Pipe - the slip pipe furnishes a hard, corrosion resistant surface that reduces friction between the slip pipe and packing material. For corrosive environments or line contents, slip pipe is available fabricated of stainless steel.

Adjustable Packing Gland - alternating rings of lubricated flax and rubber are packed tightly into the packing area of the body by the adjustable packing gland. This packing gland maintains a consistent compression of the flax/rubber rings to ensure a tight, leak proof seal between the slip pipe and body.

Lubricated Packing - rings of lubricated flax provide the "lubrication" to the slip pipe ensuring a smooth expanding/contracting movement while the square rubber rings secure the water tight seal. This packing area is easily accessible, without disruption of service, should repacking be required.

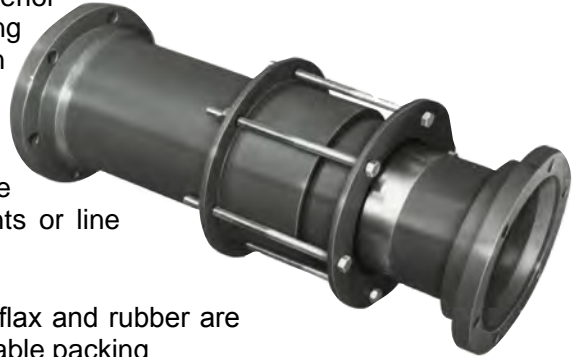

Typical Application:
Connection
Permanent

Provides linear expansion/
contraction in systems
experiencing line content or
environmental thermal fluctuations.

HOW TO ORDER

For pricing and engineering, the following information must be furnished:
JCM 801 and 802 are available fabricated of 304 stainless steel or 316 stainless steel

Type of pipe
Outside diameter of pipe
Type of End Connections
Line Contents
Minimum and maximum temperatures
Maximum working pressure
Material and Coating specifications

JCM 802 Double End Expansion Joints are designed for special applications such as middle of line use where expansion joint body can be anchored. This fitting permits up to 10" total pipe movement, 5" on each end, with properly anchored body.



JCM Fabricated Expansion Joints

JCM Expansion Joints are available as Model 801 Single End design or Model 802 Double End Expansion Joint and are available with the following options:

- (1) Weld-On Ends without Limit Rods
- (2) Weld-On Ends with Limit Rods
- (3) Flanged Ends without Limit Rods
- (4) Flanged Ends with Limit Rods
- (5) Mechanical Joint Ends without Limit Rods
- (6) Mechanical Joint Ends with Limit Rods

Other end connections available

Increased or decreased amounts of pipe movement capability

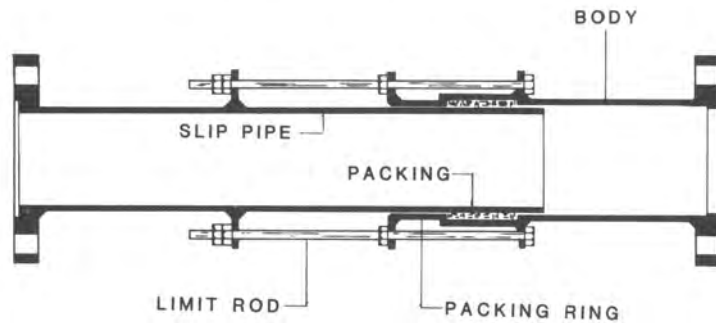

JCM 801 Single End Expansion Joint

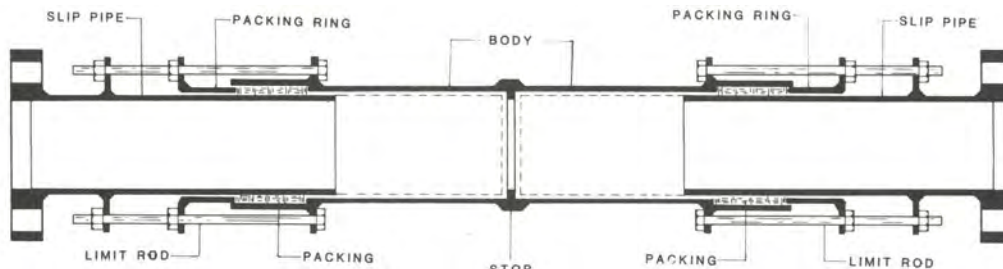

JCM 802 Double End Expansion Joint

JCM Expansion Joint - Typical Specifications

Expansion Joints shall be of the externally guided, slip joint type, permitting up to 10" of concentrated pipe movement. The packing gland shall have alternate rings of lubricated flax and rubber specially compounded for use with water, salt solutions, mild acids, bases, natural gas and sewage. The body of the expansion joint shall have a shop coat primer. The slip pipe shall be stainless steel. Expansion Joints shall be JCM 801 or approved equal. Expansion Joint shall be ANSI/NSF Standard 61, Annex G and ANSI/AWWA 372 Certified.

JCM Expansion Joint - Material Specifications

- BODY MATERIAL:** Carbon Steel per ASTM A-36, ASTM A-516 Grade 70 or equal. Optional 304 or 316 Stainless Steel.
- SLIP PIPE:** 18-8 Type 304 Stainless Steel. Optional 316 Stainless Steel.
- GASKET AND FLAX:** Square packing Buna-N rubber, 55 - 60 durometer, compounded for use with water, salt solutions, mild acids, bases and sewage.
Flax: Gurlock waxed, braided cord (hemp).
- LIMIT RODS:** Grade B-5
- FINISH:** Heavy coat of corrosion resistant shop coat primer.

JCM Fabricated Spools and Bypass Tees

JCM Fabricated Spools, Meter Test Spools and Tees are available in many lengths and configurations to meet specific installation requirements. Short laying lengths and precise dimensions make these fittings extremely desirable in vault applications. These fusion epoxy coated steel fittings eliminate stress cracks common to iron fittings yet provide excellent corrosion resistance for use in underground vaults.



JCM Fabricated Carbon Steel Spools - Typical Specification

Bypass Tee and Test Spools shall be manufactured to AWWA C-200 and have machine tolerances on laying length, outlet and flange alignment. Fittings shall be fusion epoxy coated, minimum 12 mils on external surfaces, minimum 12 mils on internal, dry film thickness in accordance with AWWA C-213 Standard. Fabricated Spools Expansion Joint shall be ANSI/NSF Standard 61, Annex G and ANSI/AWWA 372 Certified.







JCM Spools are available fabricated of 304 stainless steel or 316 stainless steel

JCM Fabricated Spools - Material Specification

- FLANGES:** AWWA C207 Class, D ANSI 150 lb. drilling. Optional Stainless Steel 304 or 316. Other flanges available upon request.
- BODY:** Steel Pipe or Tubing. Optional Stainless Steel 304 or 316
- FINISH:** Fusion Applied Epoxy Coating (per ANSI/AWWA C-213). Other finishes available upon request.



JCM Fabricated Spools and Bypass Tees

| | |
|--|---|
|  <p>820</p>  <p>822</p>  <p>823</p> | <p>820 Fabricated Plain End Tee 822 Fabricated Flanged x Plain End Tee 823 Bypass Tee (Flg x Flg x Flg) Sizes 3" and Larger, Available size on size and reducing</p> <p>Custom fabricated tees for cutting in services, replacing existing piping and forinstalling bypasses. The ability to meet exact length requirements, epoxycoated for extra corrosion resistance and quick shipment make these tee's realproblem solvers.</p> <p>How To Order</p> <ol style="list-style-type: none"> 1. Determine Nominal Pipe and Flange Size 2. Determine Outlet Tee/ Flange Size 3. Determine Exact Laying Length Requirements <p>Example: Flange x Flange Bypass Tee 6" Nominal Run with 4" Flanged Outlet, 10" in Length Part Number: 823-6 x 6 x 4 x 10</p> |
|  <p>831</p>  <p>832</p> | <p>831 Flange x Flange Spool with Test Outlets 832 Flange x Flange Spool without Test Outlets Sizes 3" and Larger, Available size on size and reducing</p> <p>Ideal for installing new meters and equipment where the laying length of the new equipment is shorter than the equipment being replaced. These flanged spools can make up the difference and add test outlets if necessary. Custom fabrication allows exact length requirements to be met.</p> <p>How To Order</p> <ol style="list-style-type: none"> 1. Determine Nominal Pipe and Flange Size 2. Determine Size and Quantity of Test Outlets (for 831) 3. Determine Exact Laying Length Requirements - minimum length available: Size on Size: 3" nominal size - 5-3/4", 4" - 12" nominal size - 6-3/4" <p>Example: 6" Nominal run with two (2) 3/4" Test Outlets, 10" in Length 831 Part Number: 831-6 x 6 x 3/4 x 10 with two (2) Test Outlets 832 Part Number: 832-6 x 6 x 10</p> |
|  <p>833</p>  <p>834</p> | <p>833 Flange x Plain End Spool with Test Outlets 834 Flange x Plain End Spool without Test Outlets Sizes 3" and Larger, Available size on size and reducing</p> <p>Ideal for use on installations requiring field fit up. Plain end accommodates a flexible coupling for easy adjustment.</p> <p>How To Order</p> <ol style="list-style-type: none"> 1. Determine Nominal Pipe and Flange Size 2. Determine Size and Quantity of Test Outlets (for 833) 3. Determine Exact Laying Length Requirements - minimum length available: Size on Size: 3" nominal size - 8-3/4", 4" - 12" nominal size - 9-3/4" <p>Example: 6" Nominal run with two (2) 3/4" Test Outlets, 10" in Length 833 Part Number: 833-6 x 6 x 3/4 x 10 with two (2) Test Outlets 834 Part Number: 834-6 x 6 x 10</p> |

JCM 607 Weld On Restrainer/Joint Anchor Loops

The JCM 607 Fabricated Weld On Restrainer/Joint Anchor Loops are designed to provide permanent restraint for fittings installed in carbon and stainless steel pipelines. The JCM 607 Fabricated Weld On Restrainer/Joint Anchor Loops are available fabricated of carbon steel, 304 or 316 stainless steel and can be custom designed to the specific application.

The JCM 607 consists of an appropriate number of anchor loops (dependent upon pipe size) that are permanently field welded directly to the pipeline. JCM 607's can be installed to provide restraint directly to the fitting (when anchor loops on the fitting are present) or with restraining tie rods that extend across the fitting to the opposite side pipe restraint product (JCM or third party restrainer). Quantity and size of anchor loops tie rods are determined by nominal pipe size, opposite restraint product or by customer provided information. Tie rods provided by JCM is optional.

Standard working pressure allowable: 150PSI, for higher working pressures contact JCM Industries Engineered/Technical Sales.

For quotation or ordering, the following information is required:

- Type of Pipe
- Nominal Size of Pipe
- Outside Diameter of Pipe
- Dimensions of fitting to restrain or restrain over
- Material of construction
- Pressure rating requirements
- Number & Size of restraining tie rods
- Mating Third Party Restrainer - manufacturer or bolting pattern/size
- Any special coatings, materials or customer required modifications

MATERIAL SPECIFICATIONS

BODY: Carbon Steel per ASTM A36, A516 GR 70 or equal. Optional 304 or 316 Stainless Steel.

FINISH OPTIONS: Bare, clean metal for welding

Heavy coat of corrosion resistant shop coat primer which is an excellent base for bitumastic coal tar or similar field coatings.

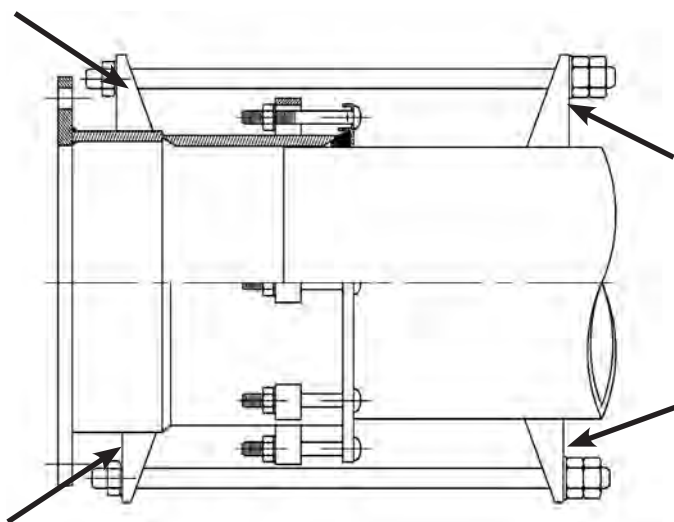

JCM 607 Weld on Restrainer/Joint Anchor Loop

Typical Application: Fitting Restraint for Carbon or Stainless Steel Pipe. Applications in which the pipe may move or pull out of an installed pipeline fitting.

Example:

**36" Steel Pipe
Weld On Restrainer Anchor Loops
JCM 607-2000 Welded to Steel Pipe**

**Installed Fitting
Flanged Coupling Adapter
JCM 303-3600X36R w/607 Loops welded to fitting**

JCM 607 Weld On Restrainer/Anchor Loops

MATERIAL SPECIFICATIONS

BODY: Carbon Steel per ASTM A-36, A-516 GR 70 or equal. Optional 304 or 316 Stainless Steel.

FINISH OPTIONS: Bare, clean metal for welding

Heavy coat of corrosion resistant shop coat primer which is an excellent base for bitumastic coal tar or similar field coatings.

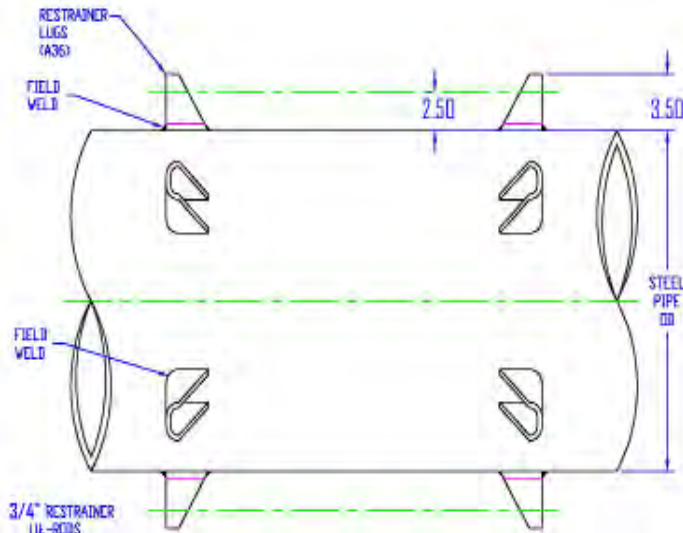

**JCM 607 Restrainer Anchor Loops
3/4" Tie Rods**

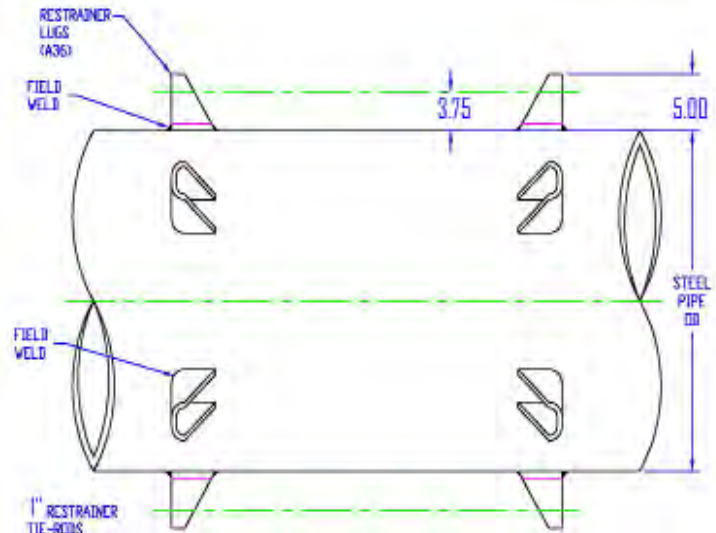

**JCM 607 Restrainer Anchor Loops
1" Tie Rods**

Typical Application: Pipe Restraint for Coupling Joint

JCM Restrainers:

JCM 607 Weld On Restrainer Anchor Loops and JCM 617 Weld On Restrainer/Anchor Loop Assembly

Installed Fitting Steel Coupling JCM 201-240007 with JCM 607 and 617 Weld On Restrainer systems

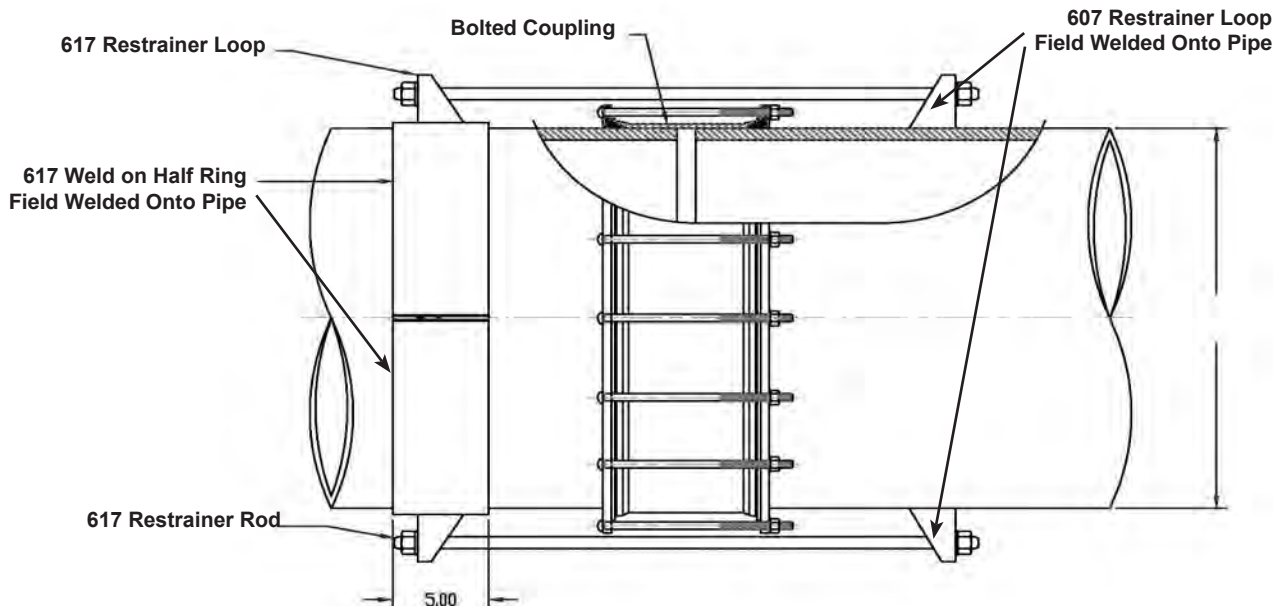

JCM 617 Weld On Restrainer/Joint Harness Assembly

The JCM 617 Fabricated Weld On Restrainer Assembly is designed to provide permanent restraint for fittings installed in carbon and stainless steel pipelines. The JCM 617 Weld On Restrainers are available fabricated of carbon steel, 304 or 316 stainless steel and can be custom designed to the specific application.

The JCM 617 consists of an appropriate number of bolting lugs/loops (dependent upon size) that are welded to (2) rolled half rings that are permanently welded to the pipeline. JCM 617's can be installed to provide restraint directly to the fitting (when anchor loops are present) or with restraining tie rods that extend across the fitting to the opposite side pipe restraint product (JCM or third party restrainer). Quantity and size of tie rods are determined by nominal pipe size, opposite restraint product or by customer provided information. Tie rods provided by JCM is optional.

Standard working pressure allowable: 150PSI, for higher working pressures contact JCM Industries Engineered/Technical Sales.

For quotation or ordering, the following information is required:

- Type of Pipe
- Nominal Size of Pipe
- Outside Diameter of Pipe
- Dimensions of fitting to restrain or restrain over
- Material of construction
- Pressure rating requirements
- Number & Size of restraining tie rods
- Mating Third Party Restrainer - manufacturer or bolting pattern/size
- Any special coatings, materials or customer required modifications

The JCM 617 consists of an appropriate number of bolting lugs/loops (dependent upon size) welded to (2) rolled half rings that are permanently welded to the pipeline.

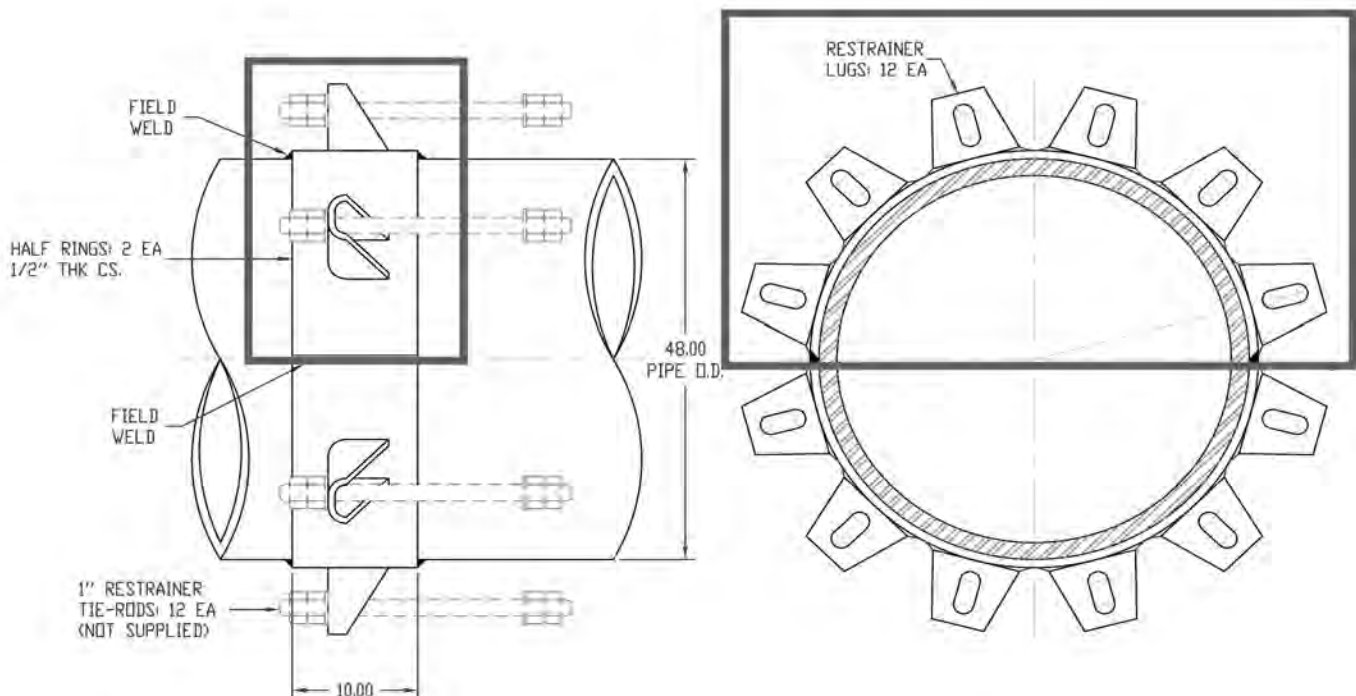

JCM 617 Weld On Restrainer/Joint Harness Assembly

MATERIAL SPECIFICATIONS

- BODY:** Carbon Steel per ASTM A-36, A-516 GR 70 or equal.
- ALL THREAD ROD:** A193 B7 Carbon Steel or equal.
- FINISH OPTIONS:** Bare, clean metal for welding
Heavy coat of corrosion resistant shop coat primer which is an excellent base for bitumastic coal tar or similar field coatings.
Fusion Epoxy Coating available.

Typical Application:
Fitting Restraint

20" Steel Pipe
Restrainer
JCM 617-2000

Installed Fitting
Transition Coupling
JCM 204-2228-2000

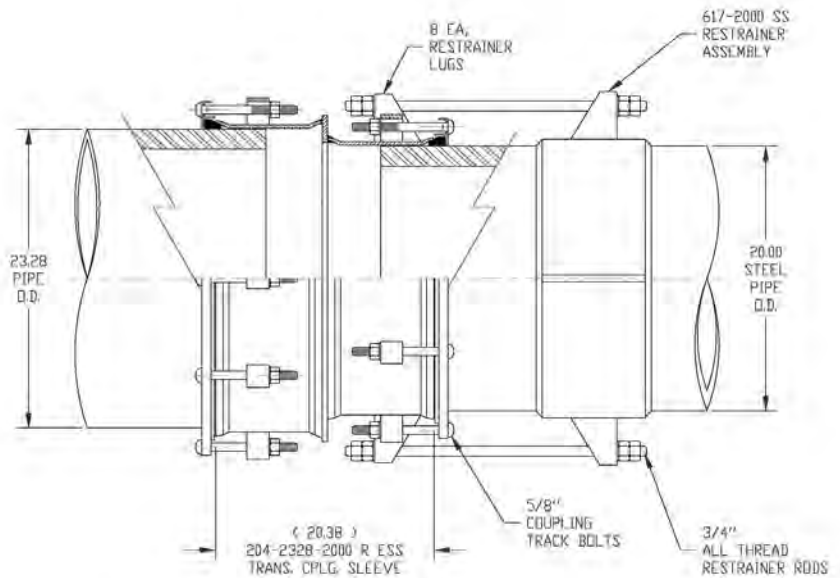

Typical Application:
Pipe Restraint

30" Steel Pipe
Restrainer
JCM 617-3000

Installed Fitting
Coupling
JCM 201-300007

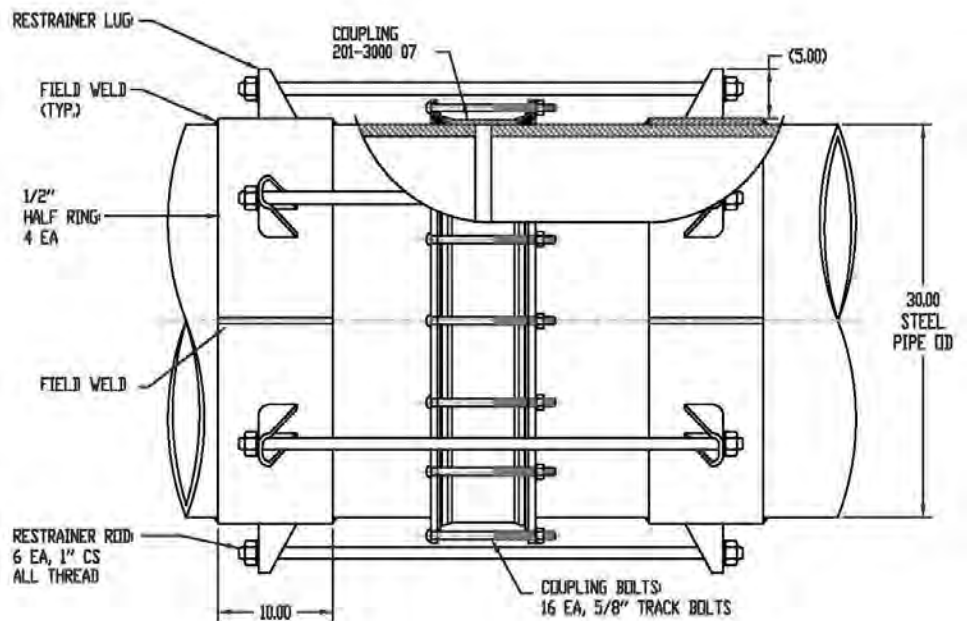

JCM INDUSTRIES, INC,
General Application Information
Fittings and Fabrications for High Density Polyethylene Pipe

JCM Products for repairing, connecting and tapping Polyethylene pipe have been tested and evaluated for their suitability and design capability. In each case JCM products have performed satisfactorily in respect to their design application. Test criteria range from short-term for special applications to long-term 1000 hour evaluations with the most common applications. Temperature and pressure cycles are also incorporated to fully address the pipe characteristics and full range of occurrences. Special monitoring equipment is utilized to produce accurate test data and for historical reference.

High Density Polyethylene Pipe (HDPE) has several unique characteristics which are taken into consideration in the following guidelines. The disregard of these guidelines and/or the installation instructions supplied with each fitting may cause unsatisfactory results and void the expressed product warranty.

HDPE Pipe considered for use must be manufactured to the recommendations set forth in the ANSI/AWWA Standard C906 and complies with criteria in reference to size.

HDPE has a high coefficient of thermal expansion and contraction along with a low modulus of elasticity. This sensitivity to pressure and temperature causes HDPE to expand and contract more than traditional water and sewer piping materials. The potential pipe expansion or contraction must be considered when assembling bolt on fittings.

HDPE will relax ("creep") at lower stress levels than other piping materials. Due to these special characteristics, the following parameters should be adhered to when utilizing JCM products for HDPE (ANSI/AWWA C901, C906).

- HDPE and bolt-on fitting connections are vulnerable to forces experienced with expansion/contraction of the pipe and require special consideration. Restraint must be considered when joining plain end pipe to ensure against pipe pull out. HDPE is manufactured with a smooth pipe wall surface resulting in a low coefficient of friction that can enable fittings to slide, shift, move, rotate and/or travel on the pipe after installation. JCM products are limited in the tolerance of axial movement of the pipe.
- JCM products for HDPE are designed for underground pressurized fluid service and are pressure rated to match the pipe SDR pressure rating or with a maximum service rating of 150 PSI (Temperature 35° -75° F/Maximum test pressure limited to rated pipe pressure or fitting, whichever is lower). For above ground applications, contact JCM Industries Technical Services.
- Pipe stiffeners must be used when joining, or connecting to, HDPE. Pipe systems must be engineered to prevent movement causing fittings to slide or rotate on the pipe. Cutting HDPE can cause the pipe to ovate or "neck" down and become egg shaped. This pipe movement can interfere with the assembly of bolt on fittings.

Thirty years of successful performance has been one of the most stringent proving grounds for JCM products and their application with Polyethylene Pipe. Generally speaking, most common potable water pressure applications utilize HDPE SDR 17 through 11. For applications on thinner wall pipe, special applications, higher pressure ratings and product usage recommendations, please contact JCM.

Note: JCM recommends fusion joints as a primary method of connection. When correctly implemented, fused joints are self-restraining and leak proof. In some instances conditions are not conducive to properly fuse the joint per manufacturers' recommendations. Mechanical fittings to join or repair HDPE are a secondary and limiting choice. The information included on this page is provided to address the known factors when repairing, joining or tapping HDPE with mechanical fittings.

Effective 01/02/18

| JCM Industries Product Description | Smith-Blair | Dresser | Ford Meter Box | Romac | PowerSeal | Mueller | Cascade |
|--|-------------|----------|-------------------|------------|------------|----------|------------|
| REPAIR FITTINGS | | | | | | | |
| 101 UCC - Standard Range | 226 | 360 | F1 | CL1 | 3121 | 500 | CDR1 |
| 102 UCC - Extended Range | 227, 228 | 361 | F2, F3 | CL2, CL3 | 3122 | 510 | CDR2 -3 |
| 103 Tapped UCC - Std. Range | 238 | 360 | F1 | CL1 | 3131 | 501-509 | CDRT |
| 104 Tapped UCC - Ext. Range | 239 | 361 | F2, F3 | CL2, CL3 | 3132 | 511, 519 | CDR2T |
| 131 All Stainless Steel UCC - Std. Range | 256 | 364 | FLS1 | *SS1 | | | |
| 132 All Stainless Steel UCC - Ext. Range | 257 | 360 | FLS2 | *SS2, *SS3 | | | |
| 133 Tapped All Stainless UCC - Std. Rng. | 264 | | | *SS1 | | | |
| 134 Tapped All Stainless UCC - Ext. Rng. | 265 | | | *SS2, *SS3 | | | |
| 136 Heavy Duty Stainless Repair Clamp | 268 | | | | 3122AS-HP | 3122AS | |
| 161 All SS Fabricated Clamp | 261 | 8364 | FS1 | SS1 | 3121AS | 540 | CR1 |
| 162 All SS Fabricated Clamp - Ext. Rng. | 262 | | FS2 | SS2 | 3122AS | | CR2 |
| 168 - 169 SS Fabricated Lightweight Clamp | | | | LSS1, LSS2 | 3121ASLW | | CSS1, CSS2 |
| SERVICE SADDLES - TAPPING SLEEVES | | | | | | | |
| 105 PVC Collar Leak UCC | 229 | | FCC | CLC | 3141 | 773 | CCLC |
| 106 Bell Joint - IPS PVC | | | FBC | 517 | | | |
| 108 UCC Sewer Pipe | | | | LSS1 | 3541 | | |
| 110 Patch Clamp | 245 | 118 | FSLC | SC | 3151A | 220-221 | |
| 111 Full-Repair Clamp | 244 | | FLSC-R | SCC | 3152 | 230, 231 | CFC |
| 112 Heavy Duty Patch Clamp | | | | | 3151HD | 220 | |
| 113 Heavy Duty Patch Clamp | 246 | 77, 79 | | | | | |
| 114 Mechanical Joint Repair Sleeve | | | | | | | |
| 116 Repair Slv for CSCP | | | | | | | |
| 143 Bell Joint Clamp - DI, CI, C-900 PVC | 274 | | FBC | 416, 516 | 3231, 3232 | | |
| 159 Abandoned Corp Cap Sleeve | | | FACC | | 3436AS | | CCAP |
| COUPLINGS - FLANGED ADAPTERS | | | | | | | |
| 201 Steel Coupling | 411 Reg | 38 | FC3-7 | 400 | 3538 | MAXI | |
| 202 Long Steel Coupling | 411 Long | 40 | FLC | - | 3540 | | |
| 203 Steel Transition Coupling | 413 | 162 | FC5 | TC400 | | | |
| 204 Steel Reducing Coupling | 415 | 62 | FC6 | RC400 | 3562 | | |
| 210 Ductile Iron Coupling | 441 | 253, 153 | FC1 | 501 | | | CR CER |
| 211 Ductile Iron Cplg - Stl, IPS PVC | | | FC1 | 501 | | | |
| 212 Ductile Iron Transition Cplg | 433 | | FC2 | 501 | 3501 | | |
| 214 Pipe End Cap Coupling | 481, 482 | 31 | FEC | EC501 | 3501EC | | |
| 215 Long Ductile Iron Couplings | 442 | | | 501 | 3501LB | | |
| 219 Restrained Ductile Cplg | | | | | | | |
| 220 Compression Coupling | 525 | 65 | | 702 | 3504 | | |
| 225 Insulating Adapter Gasket | | 3065 | | | | | |
| 230 HDPE Pipe Stiffener | | | INSERT | 206 | 3530 | | CPS |
| 241 Standard - Optimum Coupling | 461 | | FC2W | XR501 | 3506 | | |
| 242 Long - Optimum Coupling | 462 | | FC2W | XR501 | | | |
| 250 Mechanical Joint Coupling | | | MJC | | | | |
| *Items of similar materials, designs vary. Confirm with manufacturer. | Smith-Blair | Dresser | Ford Meter Box | Romac | PowerSeal | Mueller | Cascade |

| JCM Industries Product Description | Smith-Blair | Dresser | Ford Meter Box | Romac | PowerSeal | Mueller | Cascade |
|--|-------------|---------|-------------------|------------|-----------|---------|---------|
| 301 Cast Flanged Coupling Adapter | 912 | 127 | FFCA | FCA501 | 3521 | | CRFAER |
| 303 Fabricated Flg Cplg Adapter | 913 | 128 | FCA | FC400 | 3528 | | |
| 304 Reducing Fabricated FCA | 914 | 128 | FCA | FC400 | | | |
| 306 Fabricated FCA | 913 | 128 | | | | | |
| 307 Reducing Fabricated FCA | 914 | 128 | | | 3506R | | |
| 309 Fabricated Dismantling Joint | 971 | | FDJ | DJ400-05 | 3563 | | |
| SERVICE SADDLES - TAPPING SLEEVES | | | | | | | |
| 401 Single Strap Service Saddle | 311 | 291 | F101 | 101 | | DR1A | |
| 402 Double Strap Service Saddle | 313 | 291 | F202 | 202 | | DR2A | |
| 403 Wide Body Service Saddle - SS Strap | 315 | 194 | | 101S | | DR1S | |
| 404 Service Saddle - Double SS Straps | 317 | | FS202 | 202S | | DR2S | |
| 405 Ctd Wide Service Saddle - SS Strap | 315 | | FC101 | 101N | 3415 | | CNS1 |
| 406 Ctd Service Saddle - Dbl SS Straps | 317 | | FC202 | 202N | 3417DI | | CNS2 |
| 407 Ctd ServSdl - Electro Galv Strap | 311 | | | 101NU | 3411DI | | CDS1 |
| 408 Ctd Serv Sdl - Dbl Elctro Galv Straps | 313 | | | 202NU | 3413DI | | CDS2 |
| 502 Stainless Steel Service Saddle | 372 | | FS313 | 306 | 3412AS | | |
| 411 Fab Tapping Sleeve - Plain End Outlet | | | | | | | |
| 412 Fab Tapping Sleeve - Flanged Outlet | 622 | 610 | FTS | FTS420 | 3460 | | CFT |
| 419 Fab Tap Slv - Mechanical Joint Outlet | 622MJ | | | | 3460MJCS | | |
| 422 Fab Tapping Sleeve for PVC/Stl/HDPE | | 615 | | FTS419 | | *H612 | CFTLP |
| 429 Fab Tap Slv - PVC/Stl/HDPE - MJ Outlet | | | | | | | |
| 414 Fab Mechanical Joint Tapping Sleeve | *623 | | | *FTS425 | | *H615 | |
| 415 Tap Slv for CSCP | 625 | | | FTS435 | | | |
| 416 Fab Weld-On Tapping Outlet - Partial | 626 | | FWS | FTS445 | 3428 | | CFT-WO |
| 417 Fab Weld-On Tapping Sleeve | 627 | | | | 3428 | | |
| 418 Fab Threaded Outlet Tap Slv | 366 | | | | | | CFTTO |
| 425 Service Saddle for CSCP | 362 | | | | 3465CS | | |
| 432 All Stainless Steel Tapping Sleeve | 665 | 630 | FTSS | SSTIII | 3490AS | H304 | CSTEX |
| 438 All SS Threaded Outlet Tap Slv | | | | STS420T | | | |
| 439 All SS Tap Slv - MJ Outlet | 665MJ | | | SST-MJ | 3490MJAS | | |
| 440 Line Stop Fitting | 680 | 640 | | *SST-X | | | |
| 452 All SS Tap Slv - Outlet Seal Gasket | | | FTSAS | STS420 | 3460AS | *H300 | CFTSS |
| 462 All SS Tap Slv - Carbon Steel Flange | 664 | 630 | FTSS | SSTIII | 3490CS | H304 | |
| 464 SS Tap Slv - Outlet Gskt - Carbon Flg | | | FTSAS | | | | |
| 465 SS Tap Slv - Outlet Seal Gskt - Carbon MJ | 664MJ | | | | | | |
| 469 SS Tap Slv - Full Gskt- Carbon MJ | | | FTSAS | SST-III-MJ | 3490MJCS | | |
| 459 All SS Tapping Sleeve - MJ Outlet | | | FTSAS | | 3460ASMJ | | |
| FABRICATIONS | | | | | | | |
| 801 Expansion Joint - Single End | 611 | 63 | FEJ 1 | EJ400 | 3563 | | |
| 802 Expansion Joint - Double End | 612 | 63 | FEJ 2 | EJ400 | 3563 | | |
| *Items of similar materials, designs vary/ Confirm with manufacturer. | Smith-Blair | Dresser | Ford Meter Box | Romac | PowerSeal | Mueller | Cascade |

JCM Industries Comparison Chart is compiled from information available at time of printing. Product comparisons are provided for reference purposes only. Design and material criteria should be confirmed prior to specification or purchase.



Pipe Outside Diameter Guide

SMALL DIAMETER PIPE SIZES

| NOMINAL PIPE SIZE (INCHES) | 1/2 | 3/4 | 1 | 1-1/4 | 1-1/2 | 2 | 2-1/2 |
|----------------------------|-----|------|------|-------|-------|------|-------|
| COPPER TUBING | .63 | .88 | 1.13 | 1.38 | 1.63 | 2.13 | 2.63 |
| STEEL & PLASTIC PIPE | .84 | 1.05 | 1.32 | 1.66 | 1.90 | 2.38 | 2.88 |

IMPORTANT: This Pipe O.D. Guide is furnished for your convenience and is based on the latest pipe standards and information supplied by pipe manufacturers. Due to occasional changes and variances in outside diameters, the pipe O.D. should always be verified before ordering fittings.

STANDARD PRESSURE PIPE SIZES

| NOMINAL PIPE SIZE (INCHES) | 3 | 4 | 5 | 6 | 8 | 10 | 12 | 14 | 15 | 16 | 18 | 20 | 24 | 30 |
|---|------|------|------|------|------|-------|-------|-------|-------|-------|-------|-------|-------|-------|
| COPPER TUBING | 3.13 | 4.13 | 5.13 | 6.13 | | | | | | | | | | |
| STEEL & PLASTIC PIPE (SDR 26,21 & SCHEDULE) | 3.50 | 4.50 | 5.56 | 6.63 | 8.63 | 10.75 | 12.75 | 14.00 | | 16.00 | 18.00 | 20.00 | 24.00 | 30.00 |
| PLASTIC IRRIGATION PIPE (PIP) | | 4.13 | | 6.14 | 8.16 | 10.20 | 12.24 | | 15.30 | | 18.70 | 22.05 | 24.80 | |
| PLASTIC SEWER PIPE (SDR 35) | | 4.22 | | 6.28 | 8.40 | 10.50 | 12.50 | | 15.30 | | 18.70 | | 24.80 | |
| PLASTIC (PVC) AWWA C-900/C-905/C-909 | | 4.80 | | 6.90 | 9.05 | 11.10 | 13.20 | 15.30 | | 17.40 | 19.50 | 21.60 | 25.80 | |
| POLYETHYLENE PIPE (IPS SIZE) | 3.50 | 4.50 | | 6.63 | 8.63 | 10.75 | 12.75 | 14.00 | | 16.00 | 18.00 | 20.00 | 24.00 | 30.00 |
| POLYETHYLENE PIPE (DIP SIZE) | | 4.80 | | 6.90 | 9.05 | 11.10 | 13.20 | 15.30 | | 17.40 | 19.50 | 21.60 | 25.80 | 32.00 |

| | | | | | | | | | | | | | | | |
|-------------------|---------------------------|------|------|------|------|-------|-------|-------|-------|-------|-------|-------|-------|-------|-------|
| DUCTILE IRON PIPE | 3.96 | 4.80 | | 6.90 | 9.05 | 11.10 | 13.20 | 15.30 | | 17.40 | 19.50 | 21.60 | 25.80 | 32.00 | |
| CAST IRON | CLASS 100 - 250 AWWA | 3.96 | 4.80 | | 6.90 | 9.05 | 11.10 | 13.20 | 15.30 | | 17.40 | 19.50 | 21.60 | 25.80 | 32.00 |
| | CLASS A AWWA PIT CAST | 3.80 | 4.80 | | 6.90 | 9.05 | 11.10 | 13.20 | 15.30 | | 17.40 | 19.50 | 21.60 | 25.80 | 31.74 |
| | CLASS B AWWA PIT CAST | 3.96 | 5.00 | | 7.10 | 9.05 | 11.10 | 13.20 | 15.30 | | 17.40 | 19.50 | 21.60 | 25.80 | 32.00 |
| | CLASS C - D AWWA PIT CAST | 3.96 | 5.00 | | 7.10 | 9.30 | 11.40 | 13.50 | 15.65 | | 17.80 | 19.92 | 22.06 | 26.32 | |

| | | | | | | | | | | | | | | | | | |
|---------------------|----------------------------|-------------------------|------|------|---|------|------|--------|--------|-------|----|-------|-------|-------|-------|-------|--|
| ABESTOS CEMENT PIPE | Class 100 | MACHINED END | 3.74 | 4.64 | | 6.91 | 9.11 | 11.24* | 13.44* | 15.07 | | 17.15 | 19.90 | 22.12 | 26.48 | 33.12 | |
| | | FLINTITE ROUGH BARREL | 3.94 | 4.90 | | 7.13 | 9.33 | 11.30 | 13.42 | 15.45 | | 17.60 | | | | | |
| | | FLUID-TITE ROUGH BARREL | 3.93 | 5.05 | | 7.16 | 9.32 | 11.46 | 13.70 | 15.36 | | 17.50 | 20.44 | 22.50 | 27.17 | | |
| | | PERMAFLEX ROUGH BARREL | | 4.84 | | 7.15 | 9.35 | 11.47 | 13.74 | 15.55 | | 17.55 | 20.50 | 22.70 | 27.15 | | |
| | | RING-TITE ROUGH BARREL | 3.95 | 4.92 | | 7.19 | 9.39 | 11.47 | 13.74 | 15.51 | | 17.65 | 20.44 | 22.68 | 27.12 | 33.80 | |
| | | MIN. STD. ROUGH BARREL | | 4.79 | | 7.05 | 9.22 | 11.25 | 13.37 | 15.36 | | 17.50 | | | | | |
| | | MAX. STD. ROUGH BARREL | | 5.26 | | 7.40 | 9.57 | 11.77 | 14.04 | 15.80 | | 17.94 | | | | | |
| | Class 150 | MACHINED END | 3.84 | 4.81 | | 6.91 | 9.11 | 11.66 | 13.92 | 16.22 | | 18.46 | 20.94 | 23.28 | 27.96 | 35.00 | |
| | | FLINTITE ROUGH BARREL | 4.40 | 5.06 | | 7.13 | 9.33 | 11.88 | 14.14 | 16.48 | | 18.72 | | | | | |
| | | FLUID-TITE ROUGH BARREL | 4.03 | 5.14 | | 7.12 | 9.32 | 11.85 | 14.11 | 16.41 | | 18.65 | 21.20 | 23.54 | 28.22 | | |
| | | PERMAFLEX ROUGH BARREL | | 5.00 | | 7.20 | 9.40 | 11.92 | 14.20 | 16.50 | | 18.75 | 21.30 | 23.64 | 28.32 | | |
| | | RING-TITE ROUGH BARREL | 4.13 | 5.07 | | 7.17 | 9.37 | 11.92 | 14.18 | 16.48 | | 18.72 | 21.30 | 23.64 | 28.32 | 35.42 | |
| | | MIN. STD. ROUGH BARREL | | 4.97 | | 7.07 | 9.27 | 11.82 | 14.08 | 16.38 | | 18.62 | | | | | |
| | | MAX. STD. ROUGH BARREL | | 5.32 | | 7.37 | 9.62 | 12.12 | 14.38 | 16.73 | | 18.97 | | | | | |
| | Class 200 | MACHINED END | 3.84 | 4.81 | | 6.91 | 9.11 | 11.66 | 13.92 | 16.22 | | 18.46 | 22.18 | 24.66 | 29.62 | 37.06 | |
| | | FLINTITE ROUGH BARREL | 4.17 | 5.32 | | 7.26 | 9.44 | 11.88 | 14.14 | 16.53 | | 18.84 | | | | | |
| | | FLUID-TITE ROUGH BARREL | 4.18 | 5.32 | | 7.36 | 9.46 | 11.88 | 14.11 | 16.44 | | 18.74 | | | | | |
| | | PERMAFLEX ROUGH BARREL | | 5.32 | | 7.25 | 9.50 | 11.95 | 14.20 | 16.55 | | 18.90 | 22.54 | 25.02 | 29.98 | | |
| | | RING-TITE ROUGH BARREL | 4.17 | 5.33 | | 7.32 | 9.50 | 11.92 | 14.18 | 16.59 | | 18.90 | 22.54 | 25.02 | 29.98 | 37.48 | |
| | | MIN. STD. ROUGH BARREL | | 5.22 | | 7.26 | 9.39 | 11.77 | 14.03 | 16.44 | | 18.74 | | | | | |
| | | MAX. STD. ROUGH BARREL | | 5.57 | | 7.60 | 9.79 | 12.12 | 14.38 | 16.88 | | 19.19 | | | | | |
| | NOMINAL PIPE SIZE (INCHES) | | 3 | 4 | 5 | 6 | 8 | 10 | 12 | 14 | 15 | 16 | 18 | 20 | 24 | 30 | |

* Flintite ME is 10.89 for 10" and 12.99 for 12" sizes.



JCM INDUSTRIES, INC.
 P.O. Box 1220 • Nash, Texas 75569-1220
 Call Toll Free 800-527-8482, Fax Toll Free 800-874-9524
 Outside U.S. Call 903-832-2581, Outside U.S. Fax 903-838-6260
www.jcmindustries.com

