

**JOSEPH G. MINISH PASSAIC RIVER  
WATERFRONT PARK AND HISTORIC AREA**

**HSLRR**

**ENGINEERING APPENDIX**

**20 MAY 2015**

## TABLE OF CONTENTS

1.0	Introduction.....	3
2.0	Project Background.....	3
3.0	Status.....	4
4.0	Project Area Site Condition Changes since the Design Memorandum of 1996.....	6
5.0	Site/Civil Design.....	8
5.1	Bulkhead Layout .....	8
5.1.1	Bulkhead Station 0+00 to 9+05 (Contract 3B).....	8
5.1.2	Bulkhead Station 9+05 to 20+03 (Contract 3A).....	9
5.1.3	Bulkhead Station 37+10 to 45+68.60 (Contract 4B).....	10
5.2	Stream Bank Stabilization, Station 57+80.10 to 92+13.59 .....	11
5.2.1	Streambank Stabilization - Riprap Design .....	13
5.3	Site Grading/Earthwork.....	14
5.4	Stormwater Management .....	15
6.0	Geotechnical .....	17
6.1	Physiography .....	17
6.2	Regional Geology.....	17
6.3	Subsurface Investigations.....	19
6.3.1	Laboratory Soils Testing .....	19
6.3.2	Suggested Soil Parameters.....	19
6.3.3	Bedrock Properties .....	20
6.3.4	Sheet Pile Driving Conditions .....	21
6.4	Geotechnical Calculations.....	21
6.4.1	Settlement Analysis .....	21
6.4.2	Stability Analysis in Streambank Stabilization Area .....	21
6.4.3	Slope Conflicts in Streambank Stabilization Area .....	22
7.0	Structural Design .....	25
7.1	Structural Design of Bulkhead Station 0+00 to 9+05 .....	25
7.2	Structural Design of Bulkhead Station 9+05 to 20+03 .....	30
7.3	Structural Design of Bulkhead Station 37+10 to 45+68.60 .....	37
7.4	Railings and Ladders .....	40
8.0	Climate Change Adaptation.....	41
8.1	Comprehensive Evaluation of Projects with Respect to Sea Level Change .....	41
8.2	SLC Guidance .....	41
8.3	Sea Level Change Calculator .....	42
8.4	Local Calculated SLC Results.....	43
8.5	SLC Impact on Project.....	43

**FIGURES**

Figure 1: Phase I Minish Park Status of Work..... 5  
Figure 2: Aerial View of Station 0+00 to Station 20+03 Project Area..... 9  
Figure 3: Aerial View of Station 37+10 to Station 45+68.60 Project Area..... 11  
Figure 4: Aerial View of the Stream Bank Stabilization Project Area, Station 57+80.10 to Station 75+00 (Beginning Section) ..... 12  
Figure 5: Aerial View of the Stream Bank Stabilization Project Area, Station 75+00 to Station 92+13.59 (End Section) ..... 12  
Figure 6: Typical Improvement Slope ..... 13  
Figure 7: Typical Riprap Protection Section..... 14  
Figure 8: Physiographic Provinces of New Jersey with Project Location Shown..... 17  
Figure 9: USDA Soil Survey of Essex County, New Jersey, 2002 Soil Conditions (Bedrock geology, modified from Drake and others, 1996 and Glacial deposits, modified from Stanford and others, 1990) ..... 18  
Figure 10: Google Earth aerial image along proposed project alignment from 6/11/2010 ..... 23  
Figure 11: Google Earth aerial image along proposed project alignment from 11/5/2012 ..... 23  
Figure 12: Re-evaluated Design of Typical Section (Station 0+00 to Station 3+00) ..... 28  
Figure 13: Re-evaluated Design of Typical Section (Station 3+00 to Station 9+05) ..... 29  
Figure 14: Bottom Elevation of Sheet piling w/ Approximate Bedrock Surface..... 32  
Figure 15: Re-evaluated Design of Typical Section (Station 9+05 to Station 14+00) ..... 34  
Figure 16: Re-evaluated Design of Typical Section (Station 14+00 to Station 15+00) ..... 35  
Figure 17: Re-evaluated Design of Typical Section (Station 15+00 to Station 20+03) ..... 36  
Figure 18: Re-evaluated Design of Typical Section (Station 37+10 to Station 45+68.60) ..... 39  
Figure 19: Historic SLC Rate at Sandy Hook, NJ ..... 42  
Figure 20: Local Calculated SLC Rate at Minish Park, NJ ..... 44

**TABLES**

Table 1: Estimated Design Parameters ..... 20  
Table 2: Minimum Penetration Depth Safety Factors ..... 26  
Table 3: Minimum Penetration Elevations for Sheet Piles ..... 31  
Table 4: CWALSHT Design Forces for Sheet Piles ..... 33

**ATTACHMENTS**

- Attachment A: Geotechnical References
- Attachment B: Site Plans

## **1.0 Introduction**

The purpose of this report is to provide a review of the conceptual design associated with Phase I of the Joseph G. Minish Passaic River Waterfront Park and Historic Area Project (Minish Park Project). As documented in the Design Memorandum dated May 1996, Phase I would provide approximately 6,000 linear feet of bulkhead, 3,200 linear feet of stream bank stabilization and wetlands restoration. This report includes the project background, project status, updated site conditions, review of geotechnical, civil, and structural components of the conceptual design and updated typical sections.

## **2.0 Project Background**

The Minish Park Project is located along the west bank of the Passaic River between Bridge and Brill Streets in the City of Newark, New Jersey (refer to Figure 1). This reach of the Passaic River is eroded, deteriorated and environmentally degraded due to past commercial and industrial use and flooding. The project area today has undergone great change. Many of the industrial enterprises are no longer in operation, the buildings have been razed, and the properties abandoned. However, significant cultural and historic resources still exist within the general vicinity of the project area.

The proximity of the area to the Passaic River and downtown Newark presents opportunities to utilize the open space for recreation, cultural and educational activities. The development of the Minish Park Project has evolved through the years to keep pace with adjoining development and various stakeholder and transportation projects in the region. In light of the renewal of the commercial downtown area of Newark near the Passaic River, the project area is viewed as an environmental resource to be restored. The overall concept of the project is to construct environmental and other stream bank stabilization measures (including bulkheads, recreation, greenbelt, and scenic overlook facilities). The recommended plan presented in the Design Memorandum included three phases. Phase I, which is the subject of this HSLRR, was estimated to provide erosion/shore protection and environmental restoration benefits; the restoration component included wetland creation, however, this piece was removed from Phase I due to the discovery of a Superfund site. Phase I does require wetland mitigation, which will occur offsite from the project area. Phases II and III would include a waterfront walkway and park recreation facilities providing recreation, social and economic benefits.

### 3.0 Status

Construction of the Phase I bulkhead, stream bank stabilization and wetland mitigation for the Minish Park Project is being carried out under multiple separate contracts. Work that started in 2000 includes 2,922 linear feet of bulkhead that was built to the standards at the time of design. Based on site visits and past storm events, it was determined that the existing construction remains serviceable. Remaining Phase I work to be constructed, which is the focus of this HSLRR, includes 2,858 linear feet of bulkhead, 2,658 linear feet of stream bank stabilization, 1.68 acres of wetland mitigation, and the installation of railings and access ladders along the bulkhead including those sections previously completed (See Attachment B- Site Plans). The new bulkhead to be constructed will be a standalone structure. It will be separated from the existing construction thru expansion joints with pre-installed waterstops.

Figure 1 and the following list summarizes the status of the Phase I project elements starting at the upstream project limit at Bridge Street and continuing downstream to Brill Street:

Contract 3B Station 0+00 to Station 9+05 - bulkhead, railings and access ladders not yet constructed

Contract 3A Station 9+05 to Station 20+03 – bulkhead, railings and access ladders not yet constructed

Contract 1 Station 20+03 to Station 24+48.57 - bulkhead construction completed; railings and access ladders not yet constructed

Contract 2 Station 24+48.45 to 37+10 - bulkhead construction completed; railings and access ladders not yet constructed

Contract 4B Station 37+10 to 45+68.60 - bulkhead, railings, and access ladders not yet constructed

Contract 4/4A Station 45+68.60 to 57+80.10 - bulkhead construction completed; railings and access ladders not yet constructed

Station 57+80.10 to 62+00, Station 69+75 to 92+13.59 – stream bank stabilization areas not yet constructed

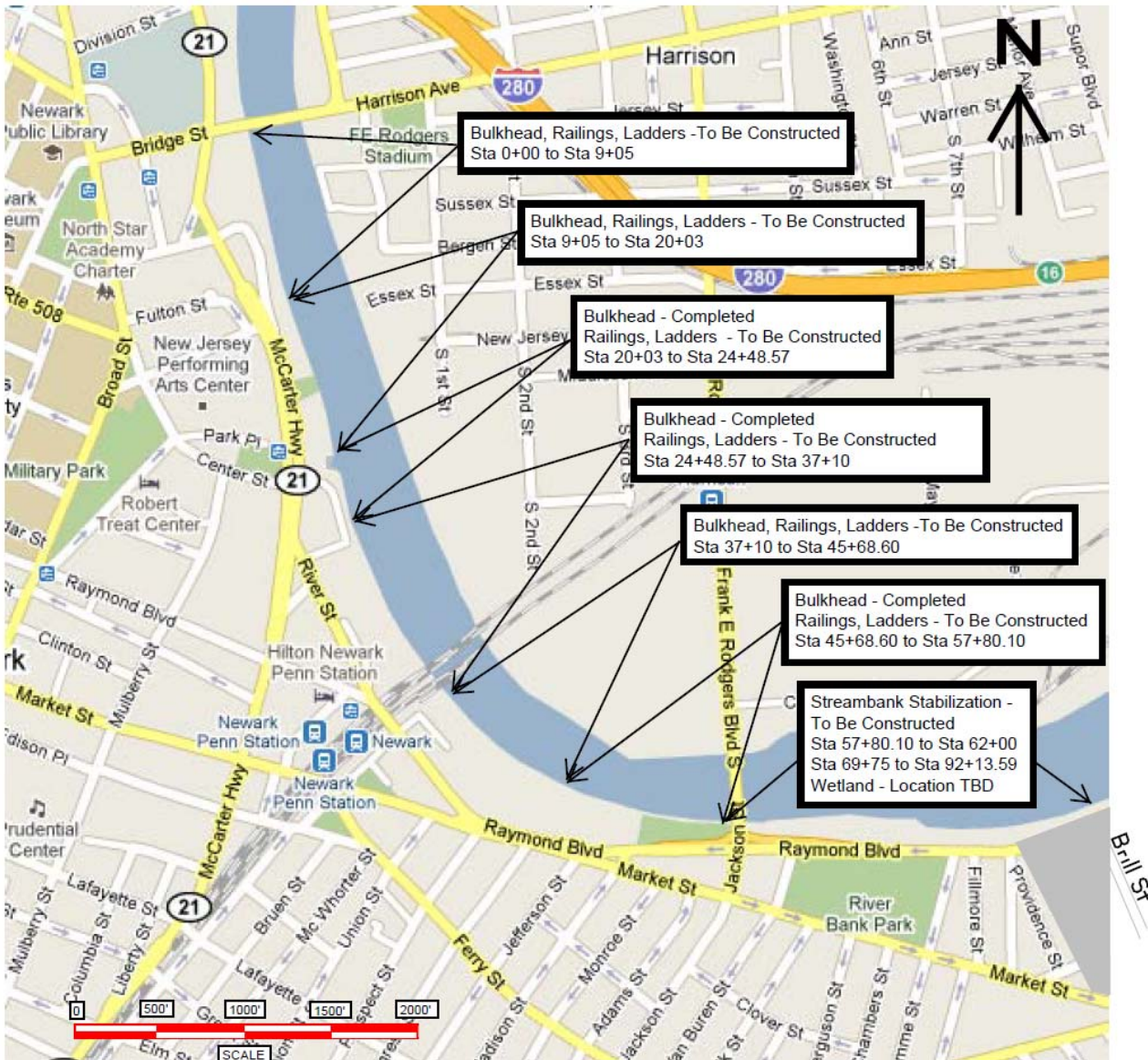

**Figure 1: Phase I Minish Park Status of Work**

#### **4.0 Project Area Site Condition Changes since the Design Memorandum of 1996**

The site conditions in the project area have changed since completion of the Design Memorandum (DM) in 1996. The plans in the DM were developed using topographic mapping from 1994. Subsequent to completion of the DM, more detailed topographic mapping of the entire Phase I area was prepared in October 1997. The 1997 topographic mapping was used to develop the contract plans for the segments of the bulkhead constructed to date, as well as for the preliminary plans for the remaining Phase I work. Since then, in preparation for final design of the remaining Phase I bulkhead, a new topographic survey was conducted in April 2010 for the area between Stations 0+00 to 20+03 where significant changes were observed. The 2010 topographic survey depicts the following major changes to this area:

1. Re-alignment and expansion of McCarter Highway (Rt. 21).
2. Construction of Rector Street Screening Facility.
3. Utility realignment and modifications.
4. Installation of sheet piling as part of a remediation project by PSEG.

The expansion of the McCarter Highway (Rt. 21) by NJDOT, resulted in major changes to the project site. With the new alignment of the Rt. 21 and an associated exit ramp, concrete/brick one/two story buildings within the alignment were demolished. Associated parking lots, garage buildings and appurtenances were also demolished. Site grades have changed due to the exit ramps from Rt. 21 expansion. Site areas outside the highway realignment are well graded and vegetated.

Rector Street Screening Facility was also a major component of the Rt. 21 widening project. The completed facility consists of an influent diversion chamber, screening facility and an 8' x 8' effluent conduit emptying into the Passaic River.

The widening and realignment of Rt. 21 as well as the construction of the screening facility, brought major utility changes to the site. Utilities in conflict were relocated, re-aligned or removed. Some of the stormwater outfalls originally proposed as part of the Minish Phase I project between Stations 0+00 to 20+03 are now in place. The size ranges from 24" to 60" diameter pipes. Two sanitary sewers that originally discharged into the Passaic River have been re-routed to the diversion chamber of the Rector Street Screening Facility.

The land from Station 4+00 to 9+05 is owned by PSE&G and the site contains contaminated soil. PSE&G is undertaking a soil remediation project in this area. As part of their work, PSE&G has

installed a sheet pile wall inland of the deteriorated bulkhead; it is not setback uniformly from the deteriorated bulkhead. Open areas as shown in the older surveys between Stations 37+50 to 45+50 are now paved parking lots.

More recent changes in the area of the proposed Phase I stream bank stabilization include park development by the City of Newark and Essex County. This includes:

- Newark Riverfront Park – This park will encompass 7.1 acres and include walking and biking trails, a floating dock for boat access, a riverside boardwalk, a community gathering and performance area, and an outdoor learning space. The first segment of this park which opened in August 2013 includes a boardwalk along the riverfront between Van Buren and Somme Street (approximate Station 60+83 to Station 71+93).
- Essex County Riverfront Park between Oxford Street and Brill Street (approximate Station 83+04 to Station 92+13). This 12.33 acre park which opened in May 2012 includes a baseball field, two playgrounds, tennis and basketball courts, an open grassy area and turf soccer field.



## **5.0 Site/Civil Design**

### **5.1 Bulkhead Layout**

This report focuses on the 2,858 linear feet of remaining Phase I bulkhead to be constructed. Bulkhead pending construction lies between Station 0+00 and Station 20+03 and between Station 37+10 and Station 45+68.60. To avoid the accumulation of debris and sediment at abrupt changes in alignment, a continuous bulkhead alignment is recommended. The typical bulkhead cross-section consists of a sheet pile bulkhead wall system with a concrete cap. The proposed bulkhead will be driven in front of the existing bulkhead on the riverside and its top elevation will be above the existing bulkhead.

The vertical alignment of the bulkhead will follow the top of wall (TOW) elevation. The horizontal alignment of the bulkhead will be the same as the alignment that was previously approved by NJDEP. The existing bulkhead will remain in place. The area on the landward side of the bulkhead will be earth filled to an appropriate grade level effectively burying the existing bulkhead in place.

Note that the vertical datum used throughout this report is referenced to NAVD29, which was prepared for site condition description and design. However, per ER 1110-2-8160, the NGVD "Legacy" datum does not represent the current authorized Federal datum represented by NAVD88. A conversion factor of 1.11 feet (NAVD88 datum is 1.11 ft above NGVD29 datum) should be used if necessary.

#### **5.1.1 Bulkhead Station 0+00 to 9+05 (Contract 3B)**

The proposed work consists of bulkhead, new stormwater outfalls and modifications, as well as site grading. The proposed bulkhead will be placed in front of the existing deteriorated bulkhead. The proposed bulkhead will start at Bridge Street (Station 0+00) and continue downstream to Station 9+05. The horizontal alignment of the proposed bulkhead is fairly straight with three small turns at Station 5+15.20, Station 7+31.37, and Station 8+82.31. The vertical alignment of the bulkhead will follow the top of wall (TOW) elevation. The TOW ranges from elevation 9.0 NGVD 1929 at Station 0+00 to elevation 11.7 NGVD 1929 at Station 9+05. The TOW along its alignment will slope at a minimum of 0.67% to a maximum of 1.0% slope.

Four 15" stormwater inlets and pipes are proposed at Station 2+00, 3+95, 5+25 and Station 8+54. Two existing 24" stormwater outfalls shall be provided with sleeve and flap valve. Site grading shall extend a distance of 40' landward from the outside face of the concrete bulkhead as explained in Section 5.3. Refer to Figure 2 for an aerial view of Station 0+00 to Station 9+05 project area in 2012.

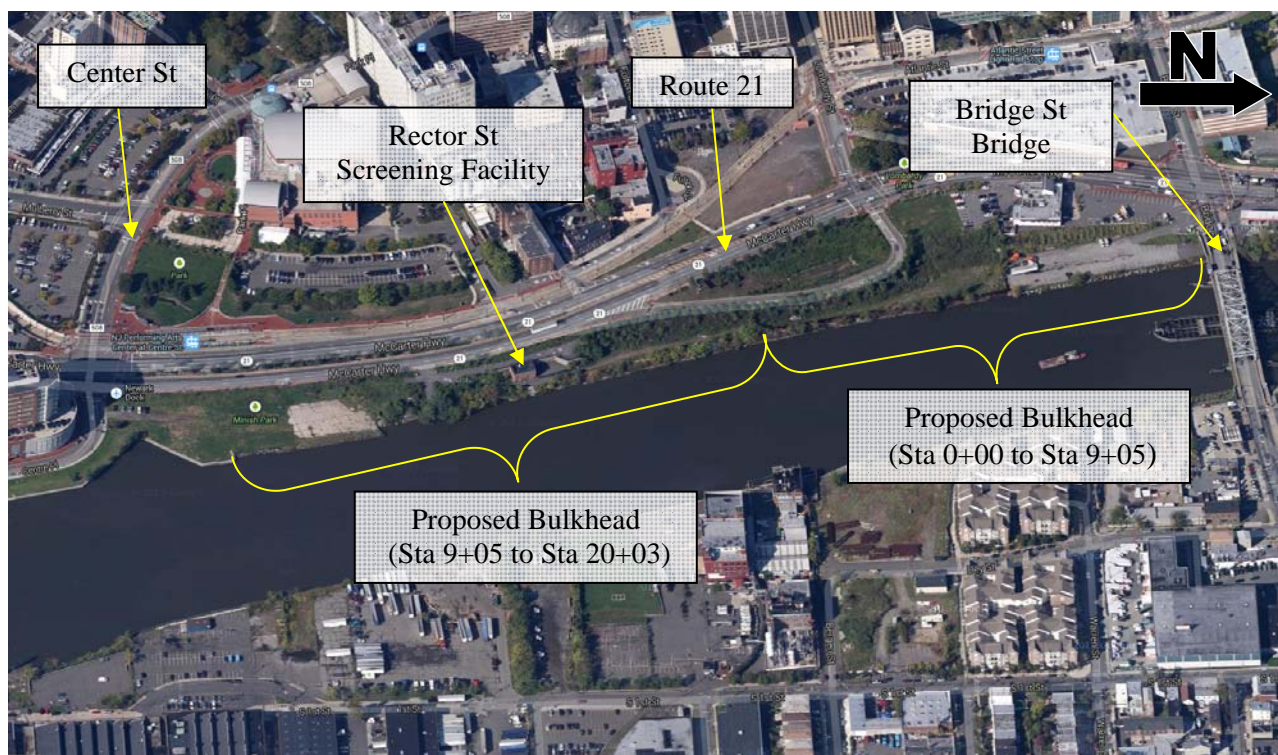

**Figure 2: Aerial View of Station 0+00 to Station 20+03 Project Area**

### **5.1.2 Bulkhead Station 9+05 to 20+03 (Contract 3A)**

The proposed work consists of bulkhead, new stormwater outfalls and modifications, as well as site grading. The proposed bulkhead will be placed in front of the existing deteriorated bulkhead between Station 9+05 and Station 20+03. The proposed alignment of the bulkhead was previously approved by NJDEP. The horizontal alignment of the proposed bulkhead is fairly straight with three small turns at Stations 10+70.59, 15+19.35 NGVD and 17+02.02. The TOW will start and meet the existing TOW at Station 20+03 at Elev. 9.5 NGVD and end at Station 9+05 at Elev. 11.7 NGVD. The TOW along its alignment will slope at a minimum of 0.05% to a maximum of 3.23% slope.

Since completion of the Design Memorandum, outfalls have been constructed by others in this reach. A steel pipe sleeve with a flap valve is proposed for existing storm drain outfalls at Station 12+19 (48" pipe), Station 18+83 (60" pipe) and at Station 13+84 (8'x8' Outfall). Three (3) 15" stormwater inlets and pipes are proposed at Station 10+00, Station 12+81 and Station 19+50. Site grading shall extend a distance of 40' landward from the outside face of the concrete bulkhead as explained in Section 5.3.

The existing granite wall abutment at Station 16+80 shall remain in place and will be preserved. The location of the existing granite wall abutment will be marked for future interpretative signage that will be placed at the completion of construction of the project along with other signage. Refer to Figure 2 for an aerial view of Station 9+05 to Station 20+03 project area.

### **5.1.3 Bulkhead Station 37+10 to 45+68.60 (Contract 4B)**

The proposed bulkhead will be placed in front of the existing bulkhead. The proposed bulkhead will start at Station 37+10 and end at Station 45+68.60. The horizontal alignment of the proposed bulkhead has four turns at Station 37+20.60, Station 39+92.06, Station 41+97.54 and Station 42+60.69. The top of wall shall meet the existing bulkhead at Station 37+10 at Elev. 8.0 NGVD 1929 and at Station 45+68.60 at Elev. 8.42 NGVD 1929.

Stormwater inlets with outfalls are proposed at Station 38+10, Station 42+25 and at Station 45+50. Site grading shall extend a distance of 40' from the outside face of the concrete bulkhead as explained in Section 5.3.

During the plans and specifications phase, the structural analysis shall again be reviewed according to current site conditions. The site and structural changes shall not change the horizontal and vertical alignment of the bulkhead. Refer to Figure 3 for an aerial view of Station 37+10 to 45+68.60 project area.

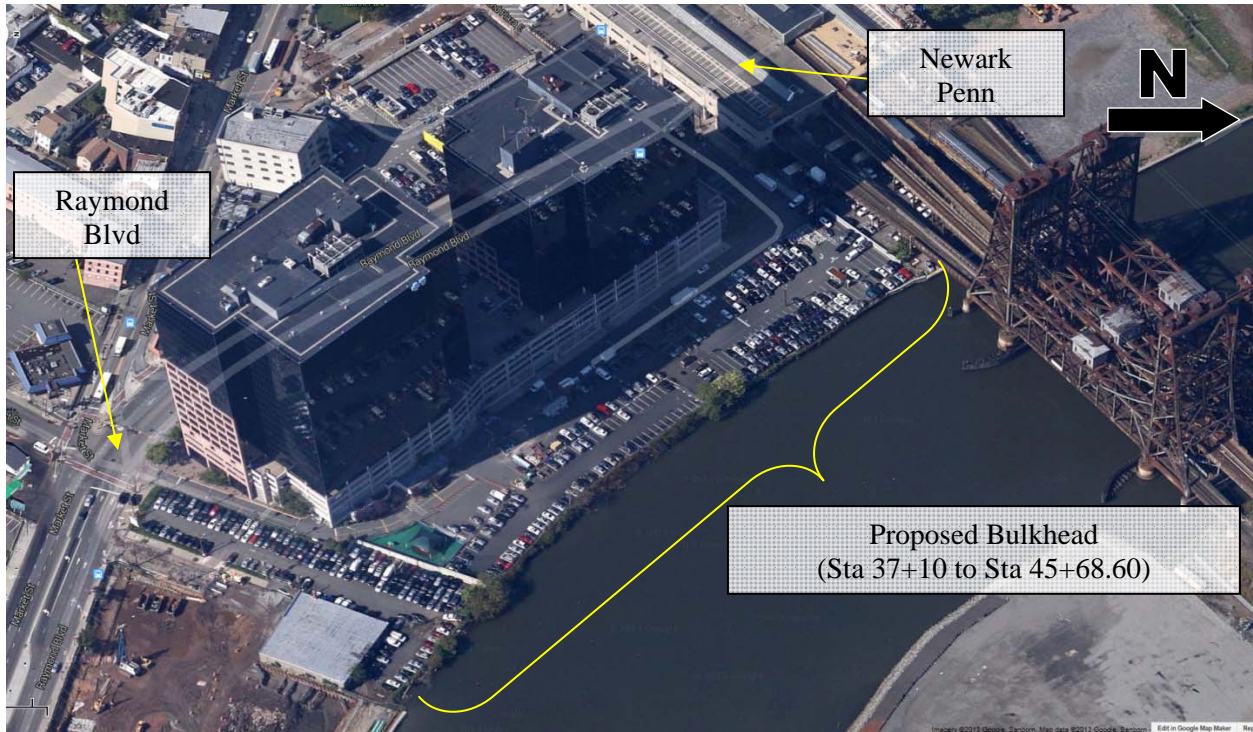

**Figure 3: Aerial View of Station 37+10 to Station 45+68.60 Project Area**

## **5.2 Stream Bank Stabilization, Station 57+80.10 to 92+13.59**

The proposed stream bank stabilization areas will require riprap to stabilize and prevent erosion. The stream bank slope will be re-graded to achieve a desirable slope (2.5H:1V) through cut and fill of materials. In order to protect the slope 6" reno mattress has been proposed from Station 57+80.10 to Station 62+00. Areas that will require riprap and slope re-grading are approximately from Station 69+75 to Station 92+13.59. A riverfront walkway has been constructed between Station 62+00 and 69+75. This waterfront facility includes sheetpile bulkhead with riprap toe protection and the stream bank slope stabilization is not needed within this reach. Some utilities may be either modified or relocated during this process. A new topographic and utility survey shall be obtained during the plans and specifications phase to verify the slope condition. The stormwater and sanitary utilities shall be reviewed to match the new grades onsite. Refer to Figures 4 and 5 for an aerial view of the stream bank stabilization project area.



**Figure 4: Aerial View of the Stream Bank Stabilization Project Area, Station 57+80.10 to Station 75+00 (Beginning Section)**



**Figure 5: Aerial View of the Stream Bank Stabilization Project Area, Station 75+00 to Station 92+13.59 (End Section)**

### 5.2.1 Streambank Stabilization - Riprap Design

Riprap slope protection is required on the improved slope for erosion control due to storm waves approximately from Station 57+80.10 to Station 62+00 and from Station 69+75 to Station 92+13.59. A 1V on 2.5H improvement slope is provided between Mean Sea Level (MSL) and approximately +15 ft NGVD as shown in Figure 6.

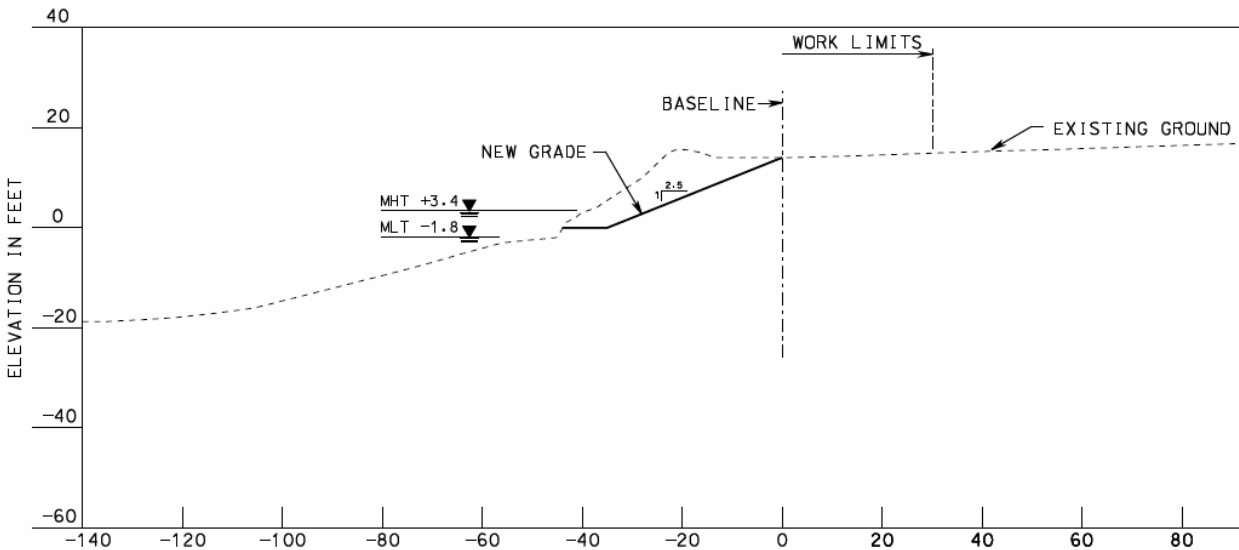

**Figure 6: Typical Improvement Slope**

#### Design Condition

The following summarizes the design condition used for calculation:

- Design Water Level: +14.7 ft NGVD for 100 year return period (based on FEMA 2013);
- Critical Water Level: providing maximum breaking wave protection on slope;
- Design deep water wave height: 2.7 ft for 100 year return period (based on M&N SWAN model);
- Design Wave at Slope: use  $H_b=3.5$  ft, breaking wave condition;
- Critical Wave Angle = 20 degrees, rock size reduction factor = 0.364;
- Boat wave can be neglected due to limit navigation condition in the waterway;

#### Design Criteria:

- Design Wave Height = 3.5 ft, breaking on slope;
- Design Slope =  $1/2.5$ ;
- Specific Gravity of Riprap= $2.65$  ( $170 \text{ lb/ft}^3$ );
- Water SG= $64.0 \text{ lb/ft}^3$  ;
- Rock Stability Factor  $K=2.5$  used in Hudson Equation for 2 layer random placement;

#### Rock Size Calculation based on Hudson Equation:

- $W = 100$  lbs for 1 on 2.5 slope;
- Use  $W_{50}=100$  lbs with size range 75 to 125 lbs;

Placement:

Place 2-layer riprap from crest of slope to MLW, provide 5 ft width splash blanket and minimum 5 ft toe width; Filter fabric shall be wrapped at both landward and seaward end of the toe slopes, minimum wrap length is 2.0 ft.

Typical Section:

As shown in Figure 7, two layers of 100 lb riprap stone will be placed on the graded slope from -2.0 ft NGVD toe of slope landward to the crest of the graded slope. Both the toe and crest widths of the riprap will be 5.0 ft with 1 V on 1 H side slope. The placed riprap thickness will be 2.0 ft. A 5.0 ft wide, 1.0 ft thickness quarry run layer will be provided landward of the crest as overtopping splash blanket. Filter fabric will be placed on the graded slope prior to placement of riprap stone. At least 2.0 ft of wrap-up shall be provided at both ends of the riprap.

Approximate Quantities:

- 100 lb Riprap Stone = 3.8 ton/LF;
- Splash Blanket (quarry run) = 0.22 ton/LF;

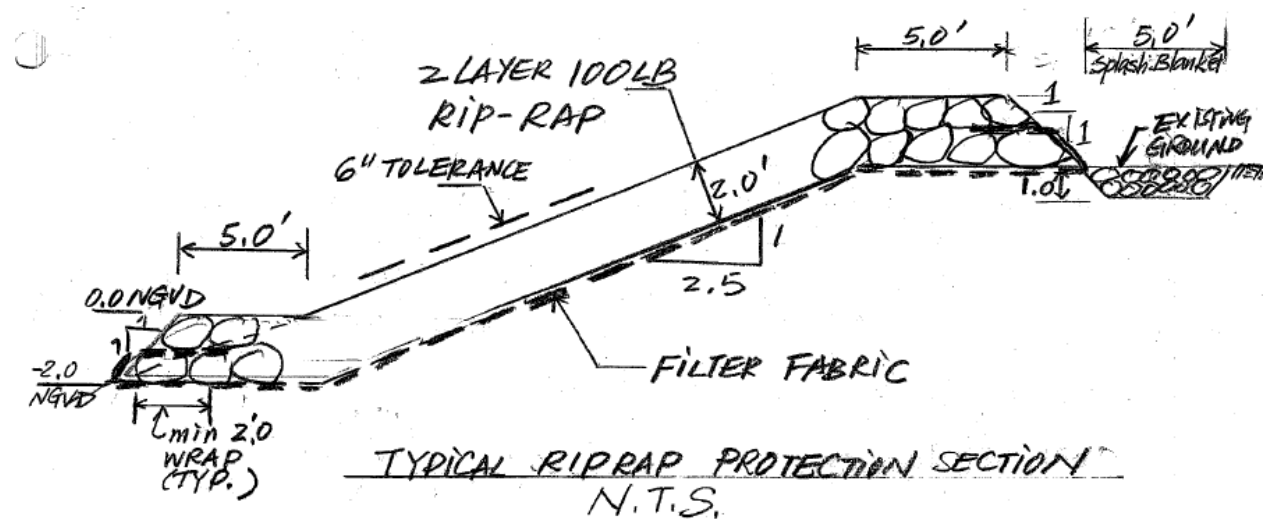

Figure 7: Typical Riprap Protection Section

### 5.3 Site Grading/Earthwork

The landward grading shall be modified to meet the proposed grades for Phase II and Phase III. Grading within the bulkhead portion shall require soil moving activities to extend at least 40' landward of the bulkhead. Southern bank of the Passaic River shall require either cut or fill to stabilize the slope with ripraps.

Landward side within the bulkhead portion shall be graded eight inches below TOW as shown on the drawings. In order to accommodate future Phase II and Phase III development, the area adjacent to the bulkhead will have a consistent 1% cross slope pitched towards the bulkhead. The proposed grading throughout all new bulkhead locations will end with 3H to 1V slope where the proposed grades meet the existing ground. In order to stabilize the slope along the southern banks of the Passaic River, cut and fill activities shall be carried out at 2.5H:1V slopes. Bottom of the slope shall be at an elevation -2 NGVD and meet the existing bank at the proposed slope. The height of the banks varies from 20', 15' and 10' along the alignment. Portion of the bank proposed with a reno mattress shall be graded with 2H:1V slope. The bottom of the slope shall be at elevation -3 NGVD and shall extended 8' high along the banks. All of the newly graded areas and areas disturbed shall be seeded.

As per the Design Memorandum dated May 1996, the soils inland and sediments in Passaic River, within the project vicinity are contaminated. Contaminated sediments shall be removed from the bottom of the Passaic River and a minimum of 12" of crushed stone shall be placed below the bottom of the concrete cap for soil stability during construction (Elev. -4.2 NGVD). Contaminated soil from the landward area shall be excavated and disposed offsite by the Contractor according to the specifications. Contaminated soil within expectable limits shall be used onsite.

#### **5.4 Stormwater Management**

The drainage system is designed to drain the stormwater runoff from the future Phase II proposed park walkways. The locations of the stormwater drains are such that drainage from future Minish Park shall be collected in a system and drained out through these outfalls being constructed. The location of these outfalls match to a conceptual walkway plan designed for the future Phase II/III park.

The proposed bulkhead is designed with a longitudinal slope that varies and follows the bulkhead TOW elevation. The bulkhead slopes vary from start to end however; the outfalls will be constructed at or near the "low points" along the bulkhead. The future Phase II proposed park walkway longitudinal slope will follow the bulkhead longitudinal slope. The cross slope was designed in this fashion to avoid discharge from directly entering the Passaic River from the landward side. This allows all surface water and any pollution or debris associated with rainfall events to be collected in a drainage collection system before being discharged through the existing outfalls.

The stormwater inlets proposed shall be in accordance to NJDOT "Type A" inlets. The inlets are proposed at or near low points and as proposed for Phase II walkway drainage system. These Phase I inlets shall collect the runoff from the Phase II walkway areas via a network of catch



basins and ultimately discharge into the Passaic River. Reinforced concrete pipes (15" dia.) will discharge the flow collected in the inlets, as designed during the Design Memorandum stage. Each outfall in its full flow condition has a capacity to discharge 14.44 cfs @ 5% slope. Therefore the pipe has a capacity to drain 2.5 acres, using Ration Method (10 yr storm event, 6 in/hr, C 0.98). The drainage inlets directly discharge into the Passaic River. The outfalls are proposed with a flap gate in order to prevent the river water entering the park during high tide flows. A 6-inch perforated sub-drain has been proposed to collect any stagnant water along the bulkhead. The sub-drains discharge to the proposed catch basins along the bulkhead.

## 6.0 Geotechnical

### 6.1 Physiography

The project area is located within the physiographic province known as the Appalachian Province. Within the state of New Jersey, the Appalachian Province consists of three lesser geologic provinces referred to as the Piedmont Plains, the Highlands, and the Appalachian Valley and Ridge. The project lies entirely within the Piedmont Plains Province. The Piedmont Plains present a low, hilly surface, broken by occasional ridges with a minimum altitude at mean sea level.

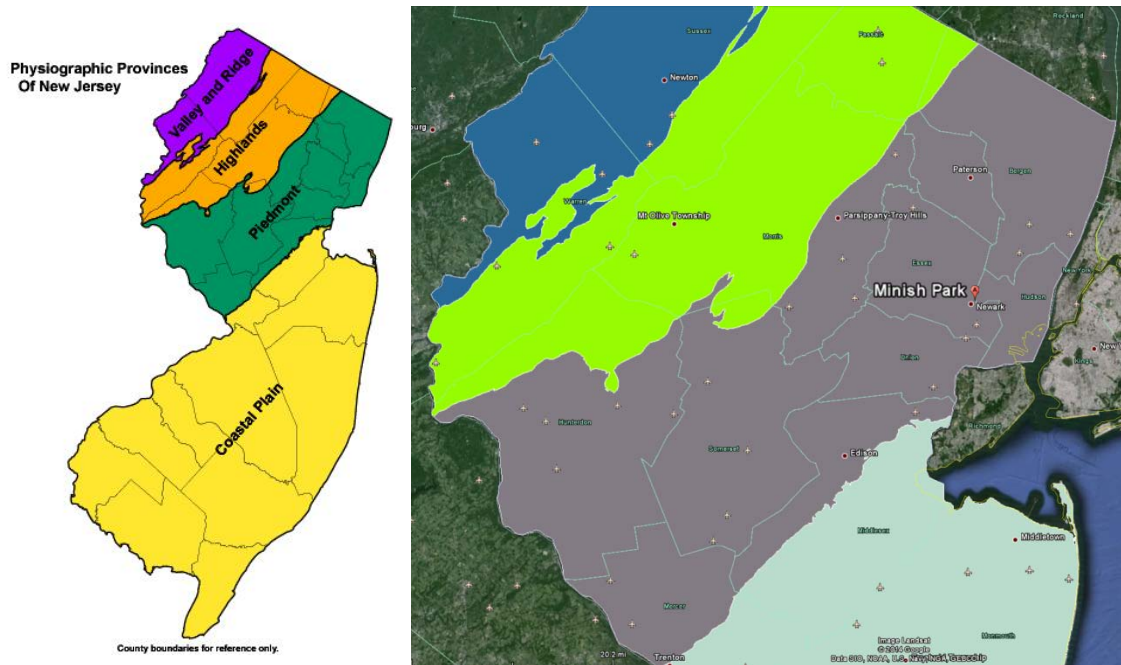
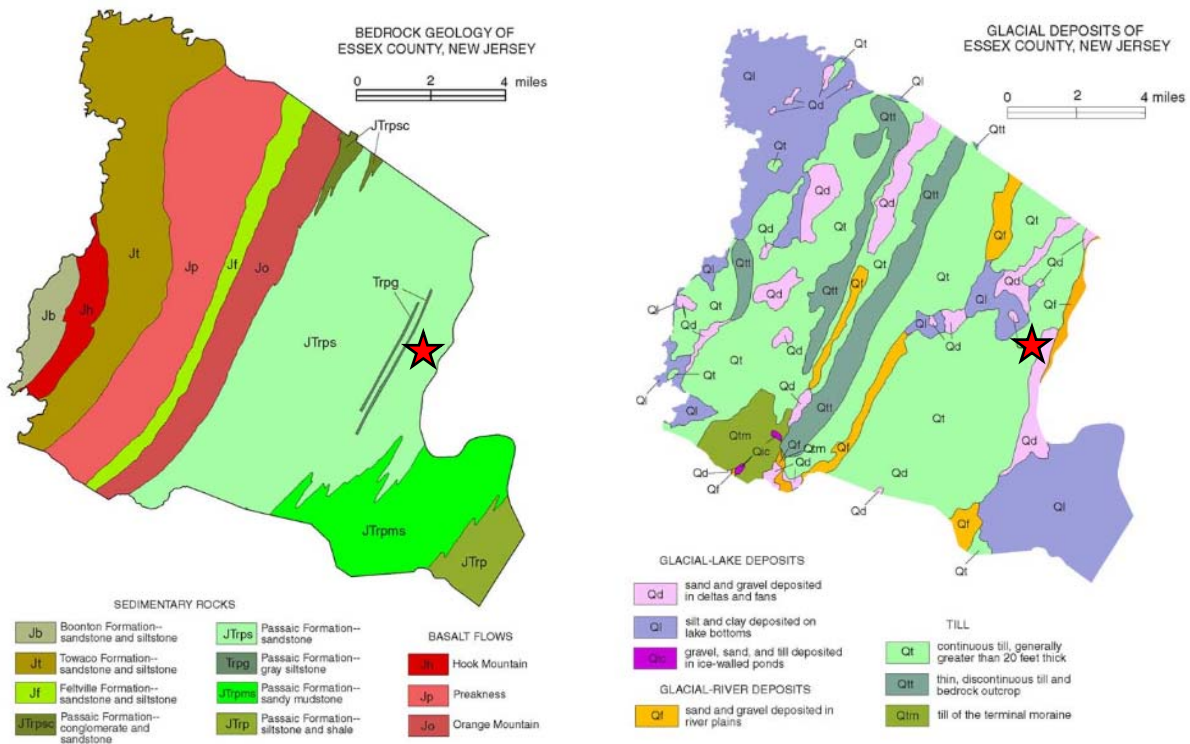

**Figure 8: Physiographic Provinces of New Jersey with Project Location Shown.**

### 6.2 Regional Geology

The Piedmont Plains is further subdivided into glaciated and unglaciated sections. Since the project area is located northeast of the Wisconsin Glacial Terminal Moraine, the project is considered to be in the glaciated section of the Piedmont Plains. The glaciated section of the Piedmont Plains consists of mostly sedimentary rocks overlain by Wisconsin glacial deposits. The consolidated rock formations consist of Border conglomerate, Brunswick shale, Stockton sandstone, diabase intrusions and basalt flows of the Newark Group and limited outcrops of serpentine and Manhattan schist. The igneous rocks form prominent ridges, whereas the land form of the sedimentary rocks is rolling to undulating. The low lying sedimentary rock is largely masked by the following Wisconsin glacial deposits: terminal moraine, recessional moraine, stratified drift, lake bed deposits and ground moraine.

Based on the USDA Soil Survey of Essex County, the project area is made up of soils mapped as Qd (see Figure 9). Soils mapped as Qd are glacial-lake deposits of sand and gravel deposited in deltas and fans. The underlying formation in the project location is mapped as JTrps and JTrpms (see Figure 9). The project area generally contains JTrps which is identified as sandstone. This location lies on the edge of another classified rock segment JTrpms, which is identified as sandy mudstone. The depth to bedrock is depicted as ranging from less than 50 feet below ground surface to 100 feet below ground surface.



**Figure 9: USDA Soil Survey of Essex County, New Jersey, 2002 Soil Conditions (Bedrock geology, modified from Drake and others, 1996 and Glacial deposits, modified from Stanford and others, 1990)**

### **6.3 Subsurface Investigations**

Combinations of three different subsurface investigations were conducted within our project area. The first investigation report is produced by Arora & Associates that is the basis for many of the design calculations proposed in the May 1996 report.

Arora report includes boring series B, H, GH, and NKG. Dames & Moore report includes boring series WT and WTH. Gannett Fleming report includes boring series S, and proposes an adjusted soil profile that includes the Arora report findings (See Attachment A – Soil Profile). B series borings were taken to a nominal depth and are therefore not included in the plan set, however are shown in the Arora and Gannett Fleming soil profiles. WT and WTH series borings located within our project area were taken in the river or at the edge of the riverline. Complete boring logs can be found in the reports produced by Arora & Associates, Dames & Moore, and Gannett Fleming.

#### **6.3.1 Laboratory Soils Testing**

Sieve Analysis, Hydrometer Analysis, Atterberg Limits, Unit Weight, Specific Gravity, Triaxial Compression, and Compressive Rock Strength testing were performed across borings located within the project area. A table of laboratory results for S series (Gannett Fleming) testing is located in Attachment A - Table C. A table of laboratory results for WT and WTH series (Dames & Moore) are located in Attachment A - Table B-1 & Report. Laboratory results conducted for GH and NKG series are located in section B-3 of referenced material (USACE Volume III Appendix B (1996)). Full laboratory testing results can be found in referenced items Gannett Fleming (1997) and USACE Volume III Appendix B (1996).

#### **6.3.2 Suggested Soil Parameters**

The following subsurface soil parameters utilized in the initial design are based on the subsurface investigation program information, results from laboratory analyses, CENAN recommendations, and engineering judgment:

**Table 1: Estimated Design Parameters**

Stratum	Report Prepared by Arora <sup>(1)</sup>			Report Prepared by Dames and Moore <sup>(2)</sup>			Results of Current Subsurface Investigations <sup>(3)</sup>			Recommended		
	γ (pcf)	c (ksf)	φ (°)	γ (pcf)	c (ksf)	φ (°)	γ (pcf)	c (ksf)	φ (°)	γ (pcf)	c (ksf)	φ (°)
FILL (Silty sand w/gravel)	120	0	30	-	-	-	-	-	-	120	0	30
Gray, clayey silt (Undrained) (Drained)	- -	- -	- -	- -	- -	- -	[96.2-106.5] (101)	[0.4-1.5] <sup>(3)</sup> (0.91) -	11.5 -	100 100	0.4 0	0 30
River Sediment/Meadow Mat (Undrained) (Drained)	100 100	0.3 0	0 23	90 -	0.2 -	0 -	- -	- -	- -	90 90	0.2 0	0 23
Alluvial Deposit (silty sand/silty, sandy gravel)	120	0	28	135	0	34	135.3	-	-	125	0	32
Alluvial Deposit (clayey silt/silty clay) (Undrained) (Drained)	- -	- -	- -	130 130	2.0 0	0 30	[124.9-125.6] (125) (125)	[2.0-3.0] (2.3) -	21	125 125	2.0 0	0 20
Till (silty sand/silty, sandy gravel)	130	0	36	135	0	40	124.2	11.5	46	125	0	40
Till (silt/clay) (Undrained) (Drained)	130 130	1.0-2.0 0	30	135	0	40	[123.4-147.9] (132) (132)	[0.45-6.0] (3.75) -	[20-44] (32)	125 125	3.0 0	0 20
Bedrock (siltstone)	Unconfined Compressive Strength →						[5410-11030 psi] (6300 psi)			5000 psi		

<sup>(1)</sup> Volume III (Geology & Soils), Appendix B - Part 1 & Part 2, of Design Memo prepared May 1996.

<sup>(2)</sup> For a summary of laboratory test results, see Table C. For field tests, see boring logs in Appendix B.

<sup>(3)</sup> Based upon pocket penetrometer readings (in field) and laboratory tests. NOTE: Values in [ ] indicate range. Values in ( ) indicate average.

The stratum identified as Till has been renamed from the previously identified Glacial Deposit in attached soil profiles.

### 6.3.3 Bedrock Properties

Weathered bedrock was encountered at varied depths below the ground surface. Only a small number of rock cores were testing as part of the Gannett Fleming report from borings S-1, S-2, and S-3. The laboratory testing results can be found in Attachment A. The bedrock found is identified as Siltstone with a range of unconfined compressive strength calculated through samples recovered in S-3 of 5,860 to 11,030 psi. Rock-core recoveries were greater than 90% however the Rock Quality Designation (RQD) of samples ranged from 24% to 50%.

At boring WTH-9, recovery was 50% and 86.7% with RQD values each 43% for two core runs. In this area bedrock was identified as reddish brown Shale and no compressive strength was calculated. Boring WT-11A contained a 93.3% recovery with an RQD value of 75. This sample was identified as reddish brown fine Sandstone and no compressive strength was calculated.

Boring GH-6 encountered refusal at a depth below ground surface of 23.5 feet with identified Siltstone coring recovery of 60.5% at a depth below ground surface of 35 to 43.6 feet with no RQD provided.

### **6.3.4 Sheet Pile Driving Conditions**

The significant amount of fill material that will be encountered while driving sheet piles to construct the bulkhead may contain various wood fragments and other materials. Additional subsurface investigations maybe needed to confirm the depth to bedrock once the glacial deposit (till) is encountered. Soil parameters utilized for sheet piling design (CWALSHT input) are all within the range of acceptable values for each stratum.

## **6.4 Geotechnical Calculations**

### **6.4.1 Settlement Analysis**

Settlement calculations were performed as part of the Arora Investigation (B, H, GH, and NKG series of borings). The additional height of fill after regrading is expected to cause long term consolidation settlement at the back of the bulkhead. Settlements were estimated in six segments located between Stations 0+00 and 56+00. Due to the nonhomogeneous subsurface soil conditions and site constraints the surcharging technique does not appear to be suitable for this project. Therefore, it is recommended that one end of the potential promenade slab be simply supported on the concrete cap. Any long term settlement which would yield underneath the promenade slab would not be visible. These calculations were performed when considering a promenade that may be constructed in the future, however it is not currently proposed as part of our contract design. Complete consolidation settlement results can be found in Attachment A – Table 5.

### **6.4.2 Stability Analysis in Streambank Stabilization Area**

Slope stability analyses were performed as part of the report prepared by USACE in 1996 as well as the report prepared by Gannett Fleming in 1998. The USACE report assessed critical sections for both dredged and undredged Passaic River cases located along the entire length of the Streambank Stabilization area (shown as Station 59+75 to Station 91+77 in those reports). Multiple critical sections were assessed for both long and short term cases, sometimes with various slope configurations. The main Gannett Fleming geotechnical report does not contain a summary of completed stability analyses; however, an additional volume of design calculations was recovered that provides stability software results. The cross sections used for Gannett Fleming prepared analyses are only for an undredged river condition. These stability

investigations were performed at cross sections generated every 200 feet between Stations 64+00 and 92+00 for three cases at each location (Steady State, Earthquake, and Rapid Drawdown). The following is a summary of noted difference in stability results from each report:

- USACE (1996) Undredged Condition: Dimensions are not shown in profile with results provided; all information is handwritten
- Gannett Fleming (1998) Undredged Condition: A load was placed at the top of slope that appears to be an approximated surcharge load of 240 psf

Current guidance (EM 1110-2-1902, 31 Oct 03) suggests factors of safety for embankments meet a minimum of approximately 1.3 for the steady state case and 1.1 for the rapid drawdown case. All Gannett Fleming cross sections rely on an undredged condition that is expected to remain for the foreseeable future and the results presented are well above the suggested factors of safety. See Attachment A for summary tables of USACE and Gannett Fleming stability analyses. The only areas of concern will be those outside the limits of the Gannett Fleming investigation and any areas that have a significantly different cross section than those used for analysis (See the Slope Conflicts section below for further details about the change in cross sections).

The area outside the limits of the most recently calculated stability sections is from Station 57+80.10 to Station 64+00, which is currently recommended to have a 2H:1V slope and utilize a reno mattress (to Station 62+00). This segment will need to be reassessed to confirm a stable slope given the recommended 2H:1V section considering the previous model contained a rip rap slope. Additional stability analysis will need to be completed in the future once an updated survey is obtained in order to confirm these conclusions.

There has been a change in MHT (Mean High Tide) and MLT (Mean Low Tide) elevations from all the calculations previously performed. Original stability calculations utilized a MLT of -3.5 NGVD29 and MHT of +2.1 NGVD29 (compared to the current MLT of -1.8 and MHT of +3.4). The additional 1.7 ft of low standing water along the riverside slope will aide in raising the factors of safety in future stability analysis.

### **6.4.3 Slope Conflicts in Streambank Stabilization Area**

It should be noted that significant construction has taken place in the area from Station 84+00 to Station 92+00 that may limit utilizing a 2.5H:1V river embankment. As depicted in the below

aerial images, construction of athletic facilities has taken place along the end of the streambank stabilization area.

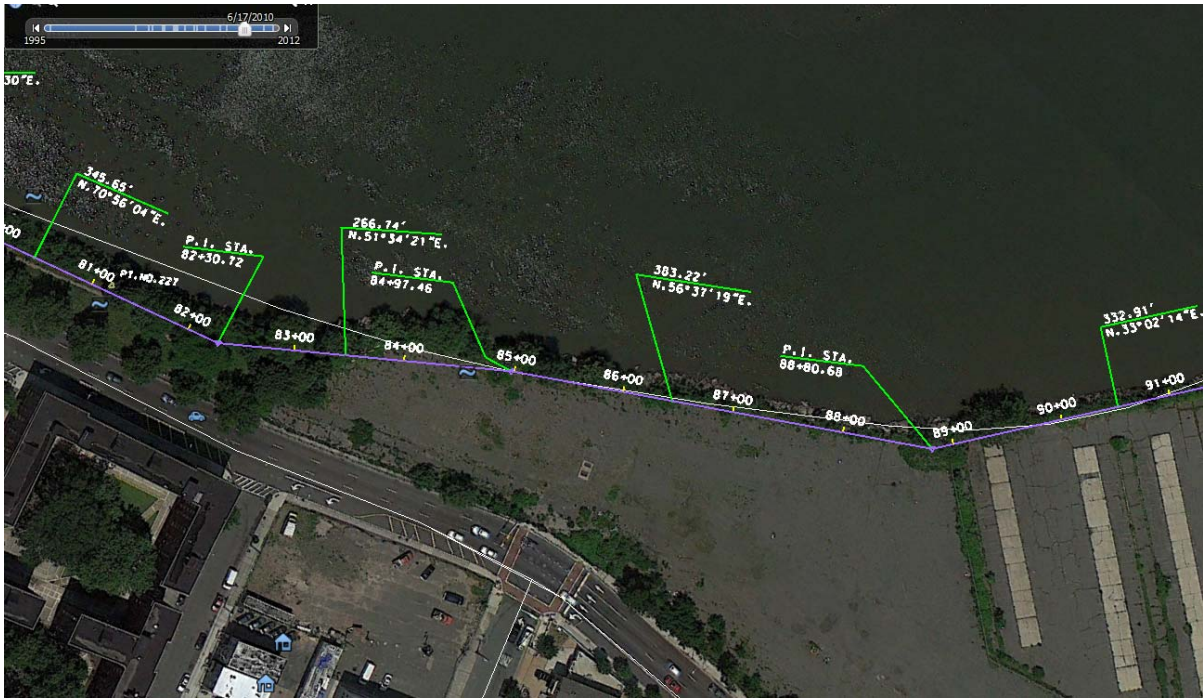

Figure 10: Google Earth aerial image along proposed project alignment from 6/11/2010

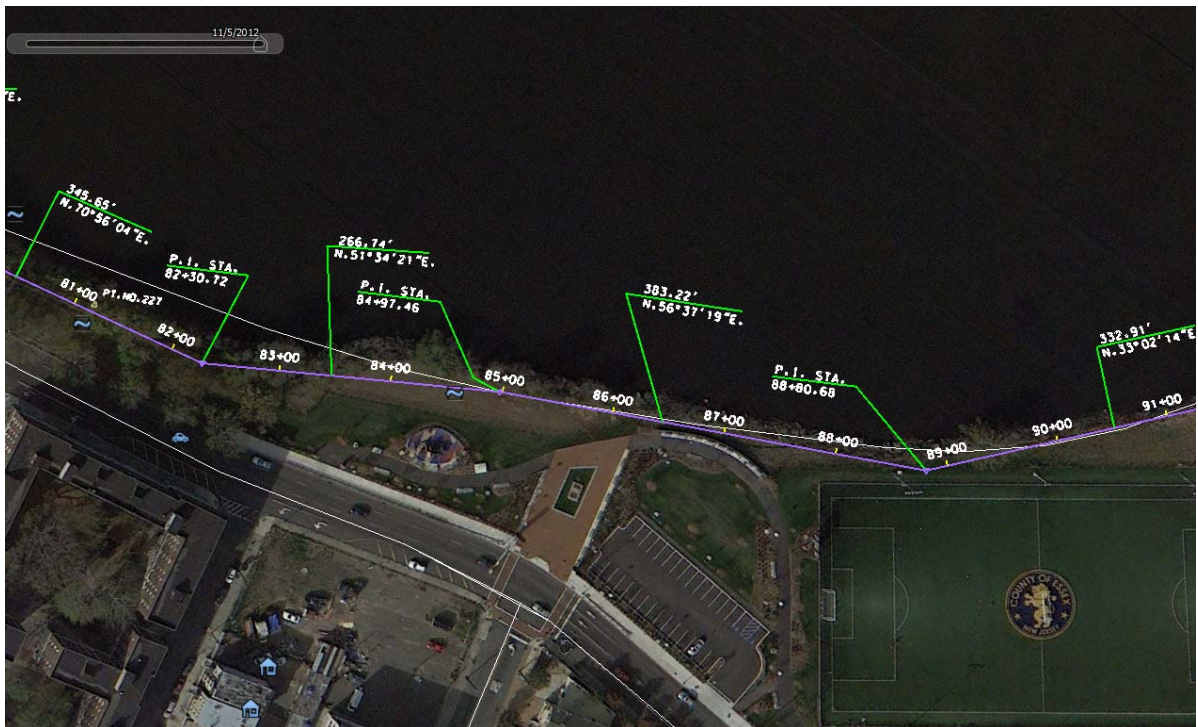

Figure 11: Google Earth aerial image along proposed project alignment from 11/5/2012



A quick analysis utilizing Google Earth Terrain features shows a total distance of 29 feet from edge of river waterline to the beginning of new construction with a change of elevation from 0 ft. to 7 ft. Without a new survey or as-built plans to confirm the current layout/elevations, in future designs a steeper slope may need to be recommended to accommodate for limited space. Additional stability analysis will need to be completed to determine a safe slope or other design feature that maybe need to be utilized.

## **7.0 Structural Design**

Subsequent to completion of the Design Memorandum, various iterations of the plans for the remaining Phase I bulkhead have been prepared. A re-evaluation of the structural design was performed as part of this HSLRR. The bulkhead is an anchored wall system made up of steel sheeting, steel piles, concrete caps, and tiebacks. This type of bulkhead system is being used to be consistent with the other contracts constructed in Minish Park Project, which used steel sheeting bulkhead systems. The contract also includes the installation of railings and access ladders along the bulkhead including those sections previously completed.

### **7.1 Structural Design of Bulkhead Station 0+00 to 9+05**

#### **Prior Design**

The typical bulkhead sections provided on prior drawings show one bulkhead wall system with a concrete cap. The bulkhead design incorporates anchors which are set at 45 degrees. The system between Station 0+00 and Station 3+00 is a combination system consisting of King Piles with “Z” Intermediate sheeting with the end of the pile embedded into bedrock. The system between Station 3+00 and Station 9+05 is the same but the end of the pile is not embedded into bedrock. The anchors from Station 0+00 to Station 9+05 are spaced at 5’-2” with a 100 kip capacity. The general notes also show a need for 160 kip capacity anchors at other spacing at several outfall structures. The sheeting is shown to be driven to varying depths from Station 0+00 to Station 9+05. The top of the concrete cap and sheet pile are shown to vary while the bottom of the concrete cap is set at El -4.2 NGVD for all sheet pile sections. The typical bulkhead section provided at tie in Station 9+05 also shows the same bottom of concrete cap set at Elev. -4.2 NGVD. The top and bottom of wall elevations will remain the same as previous 2003 plan elevations for Stations 0+00 to 9+05.

In 1998, an A/E firm, Gannett Fleming, under contract to the New York District, performed calculations that show a combined wall system consisting of HZ575A King Piles with ZH 9.5 intermediary sheets with RH16 connections from Station 0+00 to Station 9+05 with 5’-2” anchor spacing. The 2003 contract plans do not indicate specific structural members. Included were minimum properties on a per foot basis to be designed with anchor spacing as shown on the Gannett Fleming calculations. Also included were notes stating that anchor and cap details must be verified by the contractor based on the anchorage system selected.

#### **Re-evaluation Design**

A Steel Manufacturer/Supplier was contacted to verify wall system properties shown on the drawings. Both systems shown in the Gannett Fleming calculations are no longer available. The

Supplier provided old specifications sheets to verify properties of wall systems originally specified as well as 2013 Catalogue cuts of the up-to-date systems. They noted that the reason that old sheets are no longer manufactured is because over time they have become more efficient. They meet the same section properties as previously available sections, but have less area and are therefore lighter, use less steel, reduce cost vs. strength, etc. They emphasized that the connections will need to be redesigned to match the new system widths and anchors would be spaced differently.

The 1998 Gannett Fleming calculations were re-evaluated to make sure the original wall systems' properties are still appropriate for the current project area conditions. There was one major issue with the calculations within this section of the bulkhead. The issue was the safety factor used for determining the penetration depth of the sheet pile during the construction phase. The USACE has a Design of Sheet Pile Walls Engineering Manual (EM 1110-2-2504) which specifies the minimum penetration depth safety factors for sheet piles. Below list the safety factors that should be used for retaining walls.

**Table 2: Minimum Penetration Depth Safety Factors**

Loading Case	Fine-Grain Soils Silt-Clay	Free-Draining Soils Sand-Gravel
Usual	2.00 Q –Case, 1.50 S-Case	1.50 S-Case
Unusual	1.75 Q –Case, 1.25 S-Case	1.25 S-Case
Extreme	1.50 Q –Case, 1.10 S-Case	1.10 S-Case

Note: Q Case=Unconsolidated undrained, S Case= Consolidated drained

In Gannett Fleming calculations, a safety factor of 1.10 was used for the construction phase to determine the depth of the sheet piles. The construction phase of the project is considered to be an unusual loading case with a consolidated drained soil (assumed), which gives a safety factor of 1.25. As a result, the penetration depth could have been underestimated in some of the areas. Further calculations will have to be done to determine whether or not it was underestimated and what the penetration depth should be.

Basic calculations were done to determine what the update wall system should be by using the section modulus, moment of inertia, and grade of the wall system suggested by Gannett Fleming. It was determined that a HZ 880MA-14/AZ 19-700 wall system or equal is suitable to be the new wall system. If the contractor decides to use a HZ 880MA-14/AZ 19-700 wall system that provides an anchor spacing of 75.87 in (approximately 6'-4"), the minimum required capacity for the anchors will increase from 100 kips to about 130 kips. The increase in the anchor capacity

is due to the change in spacing since the spacing was 5'-2". Below shows the equation and calculation that was used to determine the minimum required capacity.

$$\text{Minimum Required Capacity} = \text{Original Minimum Capacity} * \frac{\text{New Spacing}}{\text{Original Spacing}}$$

$$\text{Minimum Required Capacity} = 100 \text{ kips} * \frac{75.87 \text{ in}}{5 \text{ ft} * \frac{12 \text{ in}}{1 \text{ ft}} + 2 \text{ in}}$$

$$\text{Minimum Required Capacity} = 122.4 \text{ kips}$$

*Roundup*

$$\text{Minimum Required Capacity} = 130 \text{ kips}$$

The cost estimate has been updated to reflect 130 kip anchors instead of the prior 100 kip anchors. For the anchors that previously required a 160 kip capacity, the new minimum required capacity is about 200 kips assuming only the spacing has changed. For the new recommended typical sections, refer to Figures 12 and 13 and further calculations will need to be done during the design phase of the project to finalize these typical sections.

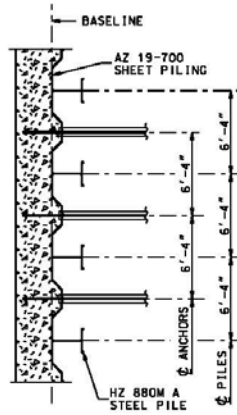

SECTION A-A

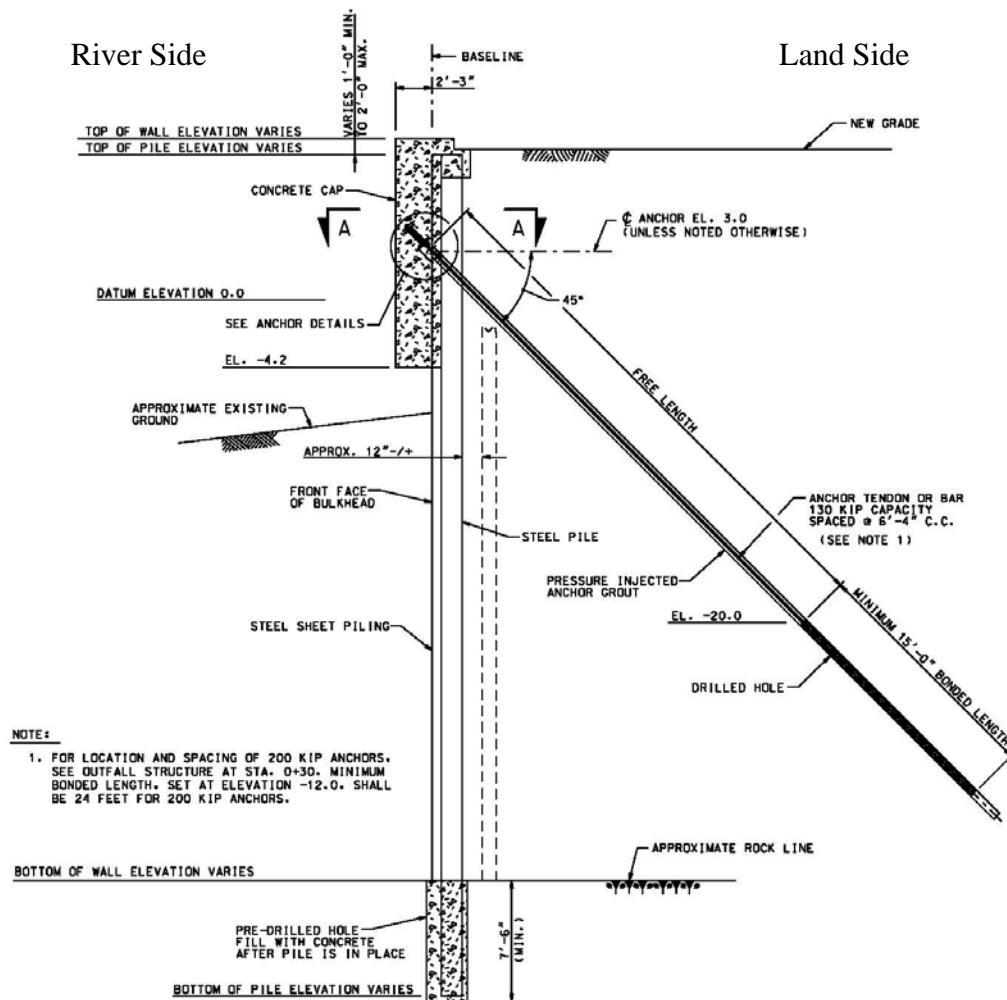

SECTION  
 STA. 0+00 TO STA. 3+00

Figure 12: Re-evaluated Design of Typical Section (Station 0+00 to Station 3+00)

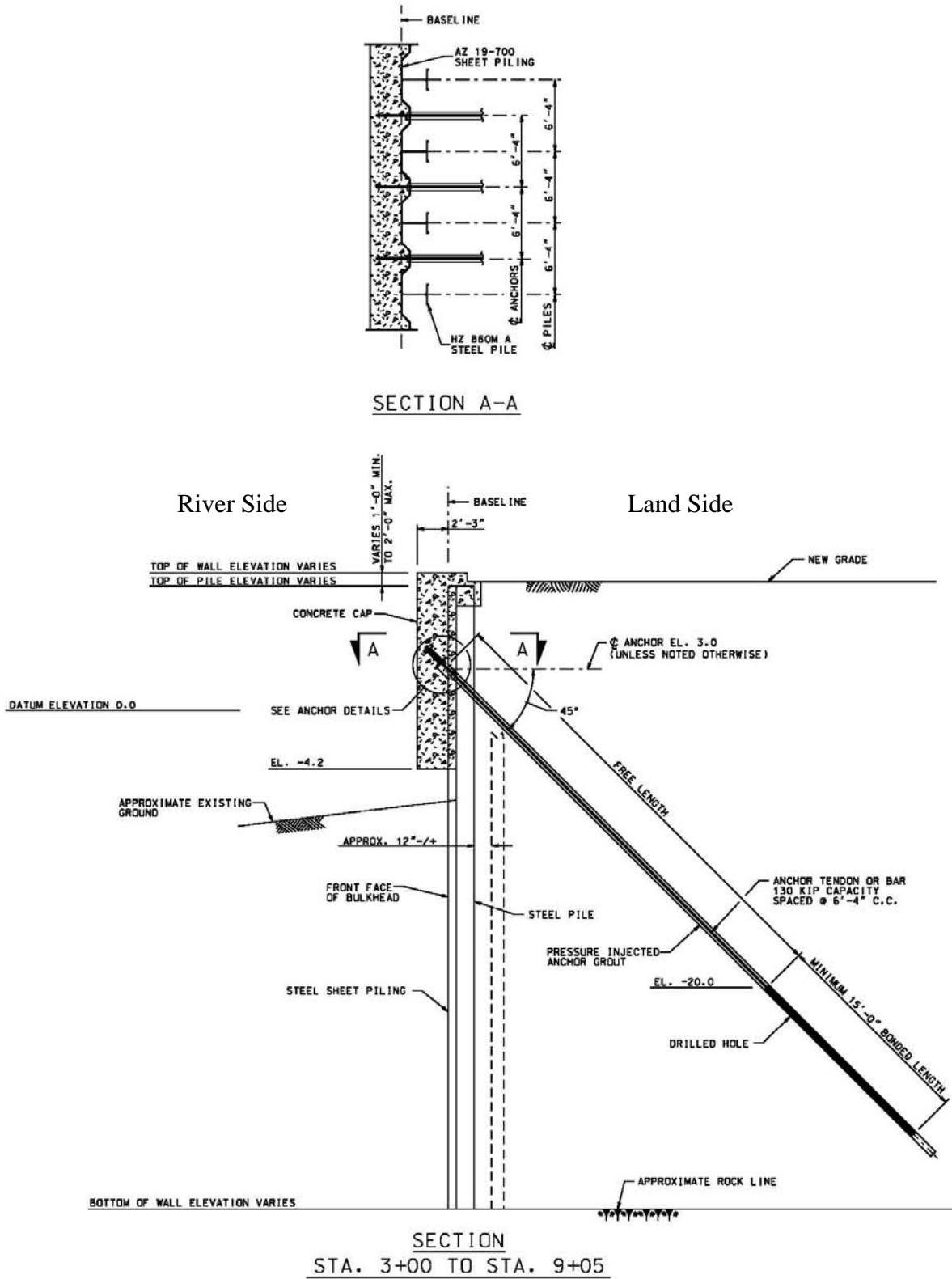

Figure 13: Re-evaluated Design of Typical Section (Station 3+00 to Station 9+05)

## **7.2 Structural Design of Bulkhead Station 9+05 to 20+03**

### **Prior Design**

The bulkhead design incorporates anchors which are set at 45 degrees. The system between Station 9+05 and Station 15+00 is a combination system consisting of King Piles with “Z” Intermediate sheeting. The anchors from Station 9+05 to Station 15+00 are spaced at 5’-2” with a 100 Kip capacity. The system between Station 15+00 to Station 20+03 consists of “Z” sheeting. The anchors from Station 15+00 to Station 20+03 are spaced at 4’-7” with a 100 Kip capacity. The general notes also show a need for 160 Kip capacity anchors at other spacing at several outfall structures. The combined wall system is shown to be driven to rock (but not embedded in rock) at varying depths from Station 9+05 to Station 15+00. The sheeting is shown to be driven to varying depths from Station 15+00 to Station 20+03. The top of the concrete cap and sheet pile are shown to vary while the bottom of the concrete cap is set at Elev. -4.2 for all sheet pile sections. The typical bulkhead section provided at tie in Station 20+03 of the constructed bulkhead also shows the same bottom of concrete cap set at Elev. -4.2. The 160 Kip anchors are also set at 45 degrees with a 4’-1 ½” spacing. The plans for the constructed bulkhead from Station 20+03 to Station 24+48.57 shows the bottom of the sheet pile at this location set at Elev. -28 NGVD. Tie in design at Station 20+03 between the beginning of the constructed bulkhead and bulkhead to be constructed is to take into account old and new sheeting configurations.

The 1998 Gannett Fleming calculations show a combined wall system consisting of HZ575A King Piles with ZH 9.5 intermediary sheets with RH16 connections from Stations 9+05 to 15+00 with 5’-2” anchor spacing. Their calculations also show AZ36 sheeting with 4’-1 ½” anchor spacing from Stations 15+00 to 20+03. The prior set of 2003 contract plans does not indicate specific structural members. Included are minimum properties on a per foot basis to be designed to with anchor spacing as shown on the Gannett Fleming calculations. (These properties are the properties of the system shown in the Gannett Fleming calculations). Also included are notes stating that anchor and cap details must be verified by the contractor based on the anchorage system selected.

### **Re-evaluation Design**

Steel Manufacturer/Supplier was contacted to verify wall system properties shown on the drawings. Both systems shown in the Gannett Fleming calculations are no longer available. The Supplier provided old specifications sheets to verify properties of wall systems originally specified as well as 2013 Catalogue cuts of the up-to-date systems. They noted that the reason that old sheets are no longer manufactured is because over time they have become more efficient. They meet the same section properties as previously available sections, but have less area and are

therefore lighter, use less steel, reduce cost vs. strength, etc. They emphasized that the connections will need to be redesigned to match the new system widths and anchors would be spaced differently.

The 1998 Gannett Fleming calculations were re-evaluated to make sure the original wall systems' properties are still appropriate for the current project area conditions. There were two major issues with the calculations within this section of the bulkhead. The first issue was the safety factor used for determining the penetration depth of the sheet pile during the construction phase. As mentioned before, the Gannett Fleming safety factor used for the construction penetration depth was different from the required safety factor. A safety factor of 1.10 was used for the construction phase to determine the depth of the sheet piles when a safety factor of 1.25 was required. As a result, the penetration depth could have been underestimated in some of the areas. A new set of calculations were done using CWALSHT, a Computer Program for Design and Analysis of Sheet-Pile Walls by Classical Methods, and Gannett Fleming's soil parameters with the updated survey data of the surroundings. Since this part of Minish Park started its design phase, a more thorough re-evaluation was conducted compare to the other bulkhead sections. The following table summarizes the findings on the minimum penetration elevations for the sheet piles using the safety factors given in Table 2.

**Table 3: Minimum Penetration Elevations for Sheet Piles**

Station	Minimum Penetration Elevation of Sheet Pile (Unusual Loading Case I)*	Minimum Penetration Elevation of Sheet Pile (Usual Loading Case II)**
9+05	-25.78	-18.87
10+50	-25.29	-20.03
12+00	-30.89	-23.74
13+50	-30.12	-24.86
15+00	-25.07	-27.57
16+00	-27.18	-33.24
17+00	-29.28	-34.55
18+50	-23.72	-30.74
20+03	-32.86	-21.67

Note: \*A safety factor of 1.25 was used for the Unusual Loading Case, which is when the sheet pile is cantilevered.

\*\*A safety factor of 1.5 was used for the Usual Loading Case, which is when the sheet pile is anchored with a tieback.



The second issue was that one of the boring logs taken by Gannett Fleming indicated that the bedrock is closer to the ground surface than their plans depicted. The proposed design had the sheet pile sitting on the bedrock. But according to the boring logs, the steel sheeting will likely hit bedrock between Station 9+05 to Station 14+00 before reaching the minimum recommended penetration depth as shown in Figure 14 below. Based on the figure below and Table 2, the bedrock will have to be drilled into to stabilize the sheet pile as a retaining wall from Station 9+05 to Station 14+00.

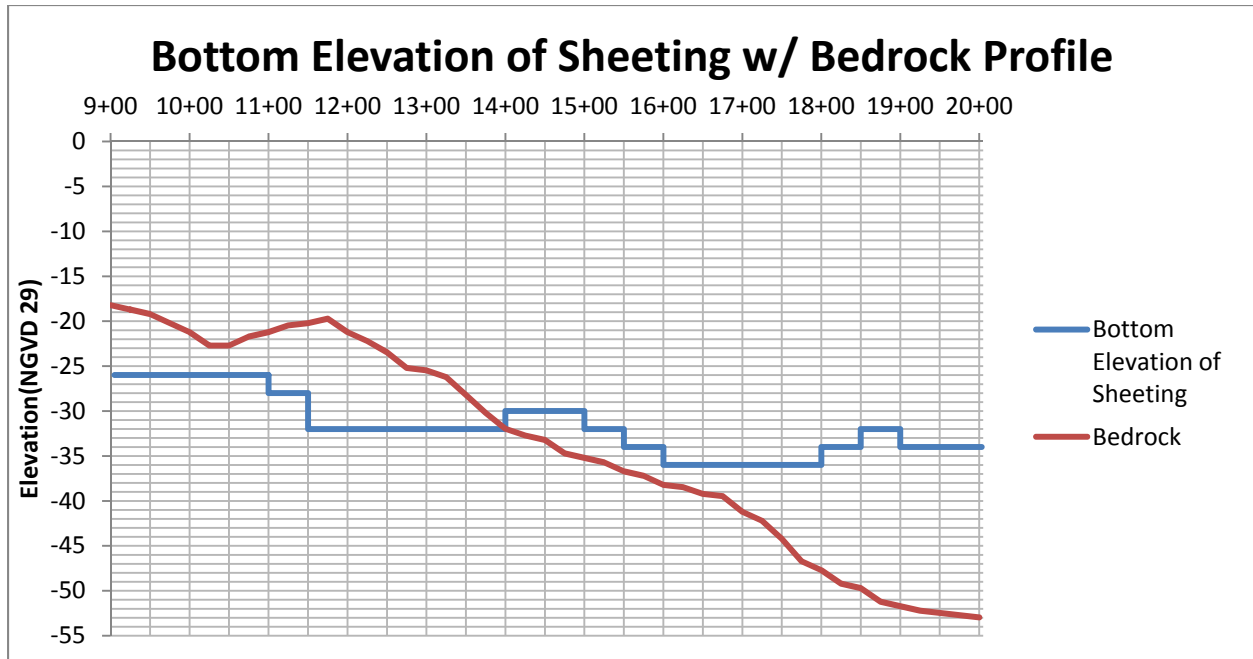

**Figure 14: Bottom Elevation of Sheetting w/ Approximate Bedrock Surface**

CWALSHT was also used to obtain the minimum moment strength required to size the sheet pile and determine the anchor force. Only Station 12+00, Station 15+00, and Station 17+00 were analyzed because they were labeled as the critical spots. At Station 12+00, the bedrock is the shallowest at elevation. At Station 15+00, the sheet pile transitions from a HZ-AZ combo type sheet pile to an AZ sheet pile. At Station 17+00, the sheet pile has the highest exposure length above the mudline on the river side. All of the moments and forces provided in Table 4 are obtain from a using safety factor of 1.

**Table 4: CWALSHT Design Forces for Sheet Piles**

Station	Minimum Sheet Pile Moment (k-ft/ft)	Minimum Horizontal Sheet Pile Anchor Force (k/ft)
12+00	-38.5	10.6
15+00	-45.3	11.6
17+00	-94.1	15.9

Since the sheet pile will be embedded into the bedrock from Station 9+05 to Station 14+00, a HZ pile along with AZ sheeting piles will be needed. So it was determined that a HZ 880MA-14/AZ 19-700 wall system or equal is suitable to be the new wall system within that area. From Station 15+00 to Station 20+03, we do not anticipate the sheet pile to be embedded into bedrock, so only AZ sheeting piles will be used. So it was determined that an AZ 38-700N wall system or equal is suitable to be the new wall system within that area. Further calculations were done and three typical bulkhead sections were developed for the project. For the typical sections, refer to Figure 15, Figure 16, and Figure 17. The anchor force for these typical sections is different from the typical sections shown in section 7.1 since more calculations were done for this area. It was determined that the anchor force doesn't have to be as high as shown in the typical sections in section 7.1. The typical sections are subject to change due to any changes to the site or availability of the shape at the time of construction of the project.

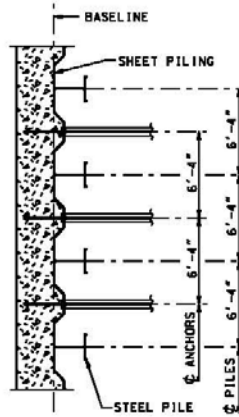

SECTION A-A

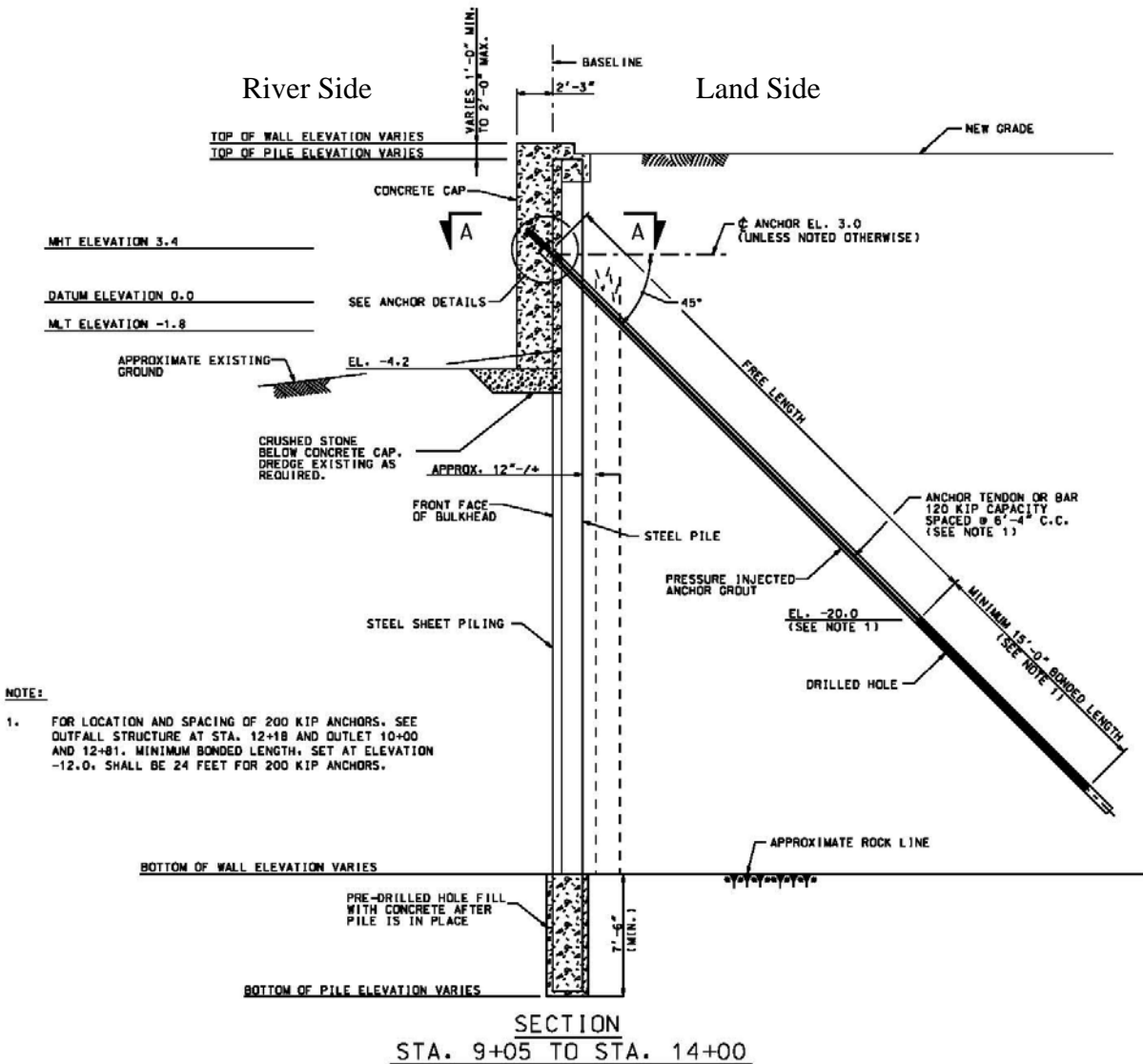
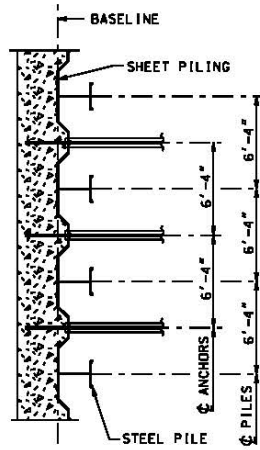

Figure 15: Re-evaluated Design of Typical Section (Station 9+05 to Station 14+00)



SECTION A-A

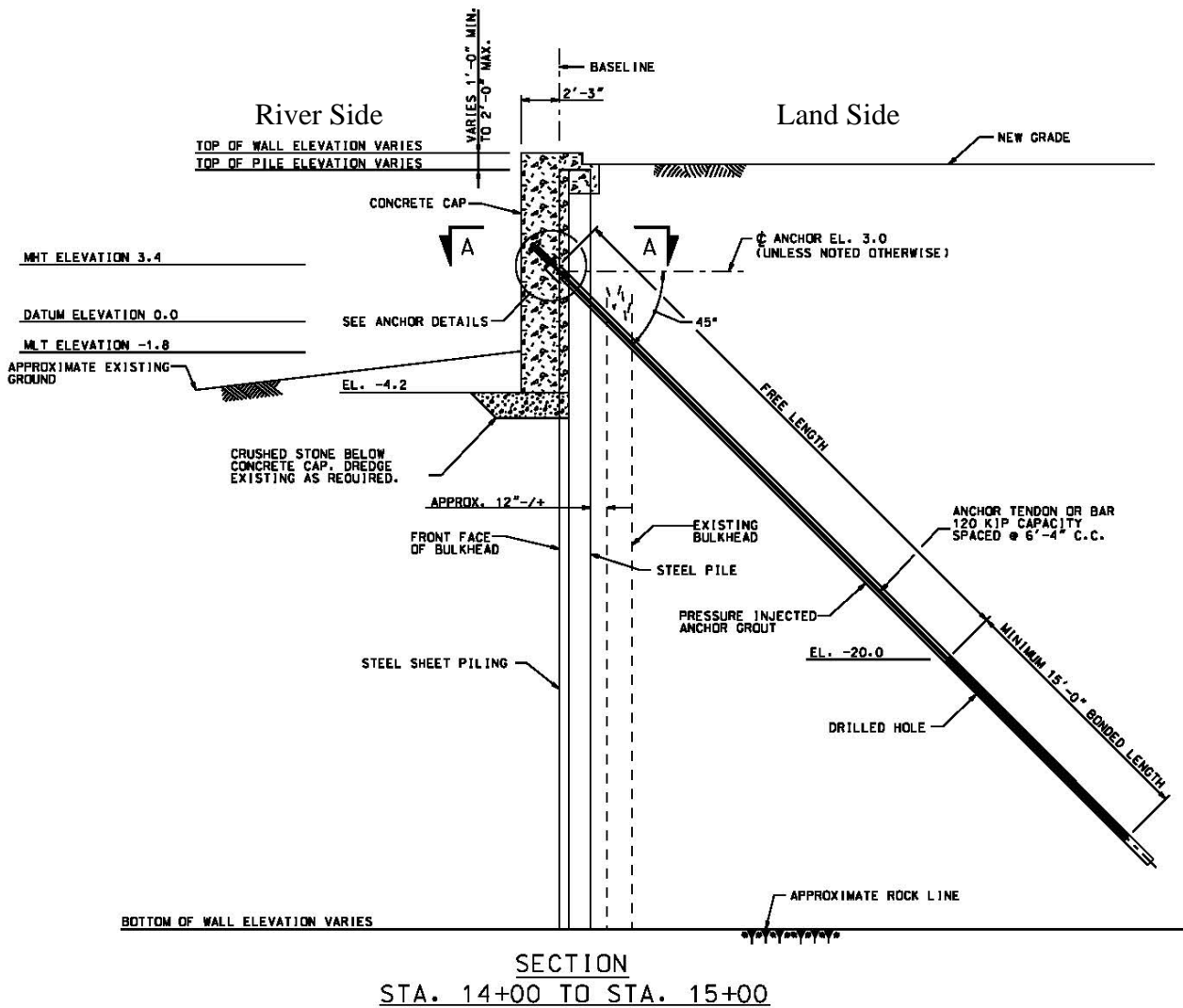
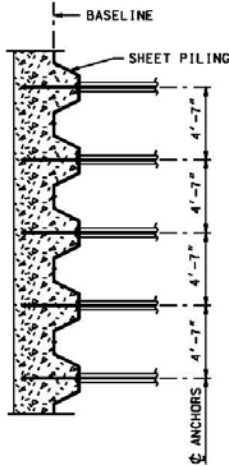
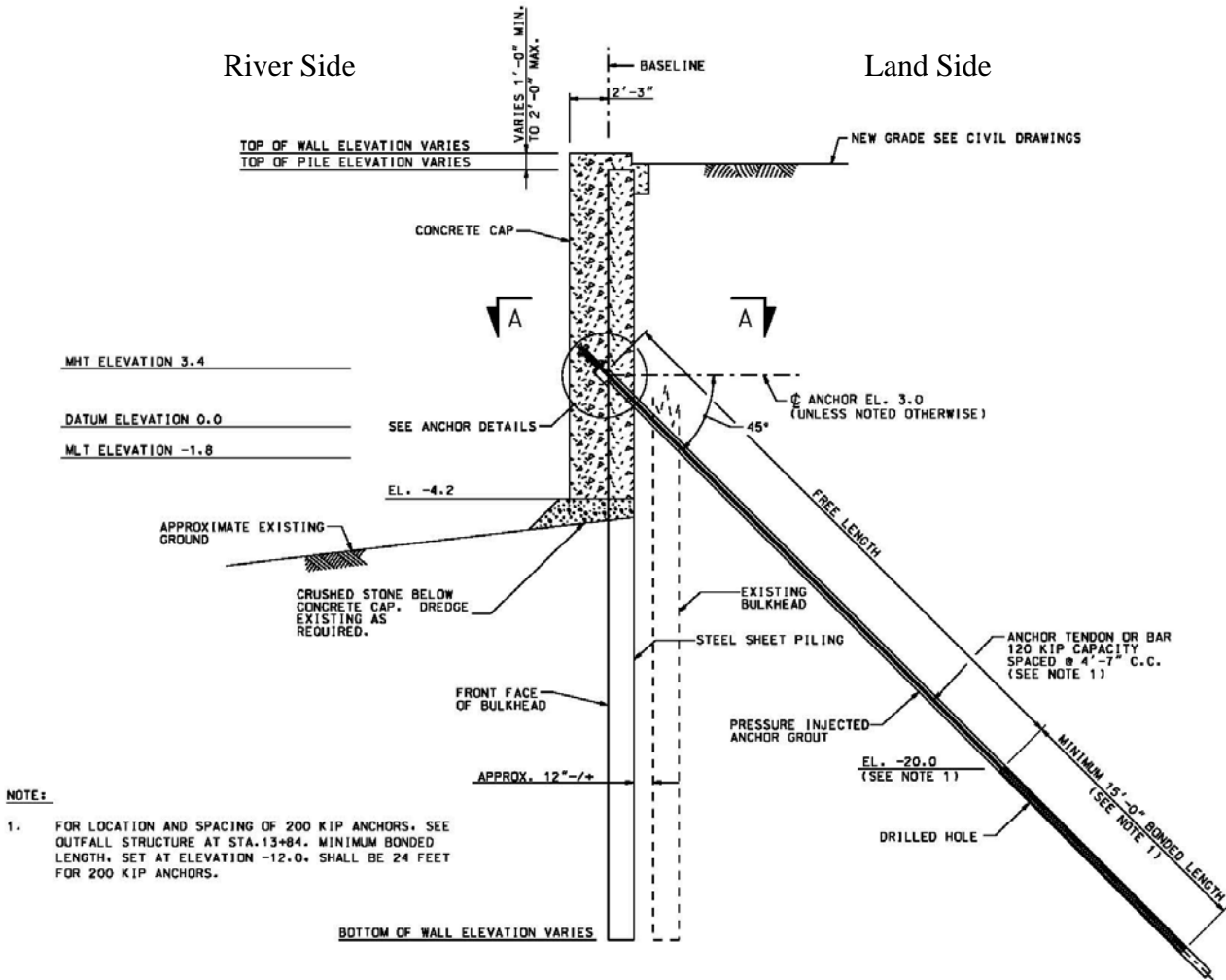

Figure 16: Re-evaluated Design of Typical Section (Station 14+00 to Station 15+00)



SECTION A-A



SECTION  
STA. 15+00 TO STA. 20+03±

Figure 17: Re-evaluated Design of Typical Section (Station 15+00 to Station 20+03)

### **7.3 Structural Design of Bulkhead Station 37+10 to 45+68.60**

#### **Prior Design**

The typical bulkhead sections provided on prior contract drawings show three different bulkhead wall systems with a concrete cap. Two of the bulkhead wall system design incorporates anchors which are set at 45 degrees. The system between Station 37+10 and Station 37+50 is a system consisting of King Piles with precast concrete lagging. The system between Station 37+50 and Station 39+60 is a system consisting of AZ Piles. The system between Station 39+60 and Station 45+68.60 is a system consisting of Box Piles. The anchors from Station 37+10 to Station 37+50 are spaced at 3'-4" with a 100 kip capacity. An additional deadman anchorage were included into the system from Station 37+30 to Station 37+50. From Station 37+50 to Station 42+17.51, there are no 45 degree angle anchors within this system. Only deadman anchorage were specified to be used within the system to account for the foundations of a future structure. The anchors from Station 42+17.51 to Station 45+68.60 are spaced at 4'-1 1/2" with a 100 Kip capacity. The general notes also show a need for 160 Kip capacity anchors at other spacing at several outfall structures. The bottom of the whole wall system is shown to be above rock at varying depths. The top of the concrete cap and sheet pile are shown to vary while the bottom of the concrete cap is set at Elev. -4.2 NGVD for all sheet pile sections. The typical bulkhead section provided at tie in to previously constructed bulkhead at Station 37+10 also shows the same bottom of concrete cap set at Elev. -4.2 NGVD.

#### **Re-evaluation Design**

The situation has changed and the foundations of the future structure are no longer going to be placed within this reach. The deadman anchorage from Station 37+30 to Station 39+60 is no longer needed. To simplify the construction process of the bulkhead wall system, the bulkhead wall system from Station 39+60 to Station 45+68.60 will be used throughout the contract. As mentioned before, the Gannett Fleming safety factor used for the construction penetration depth was less than the required safety factor. As a result, the penetration depth could have been underestimated in some of the areas. Further calculations will have to be done to determine whether or not it was underestimated and what the penetration depth should be, but the bottom of the wall system is not expected to hit bedrock. The bottom the wall system will be above the bedrock at varying depths. The updated system for Station 37+10 to 45+68.10 is shown in Figure 18. The anchor force mentioned in the typical section is different from the anchor forces mentioned in Figures 12 to 17 since the system for this area still exist. So the anchor forces will remain the same as the anchor forces proposed in the original design.

The most recent topographic survey for this area is from October 1997. The area has not changed since then. The top and bottom of wall elevations will remain the same as on the prior

2004 contract plans. The typical sections are subject to change due to any changes to the site or availability of the shape at the time of construction of the project.

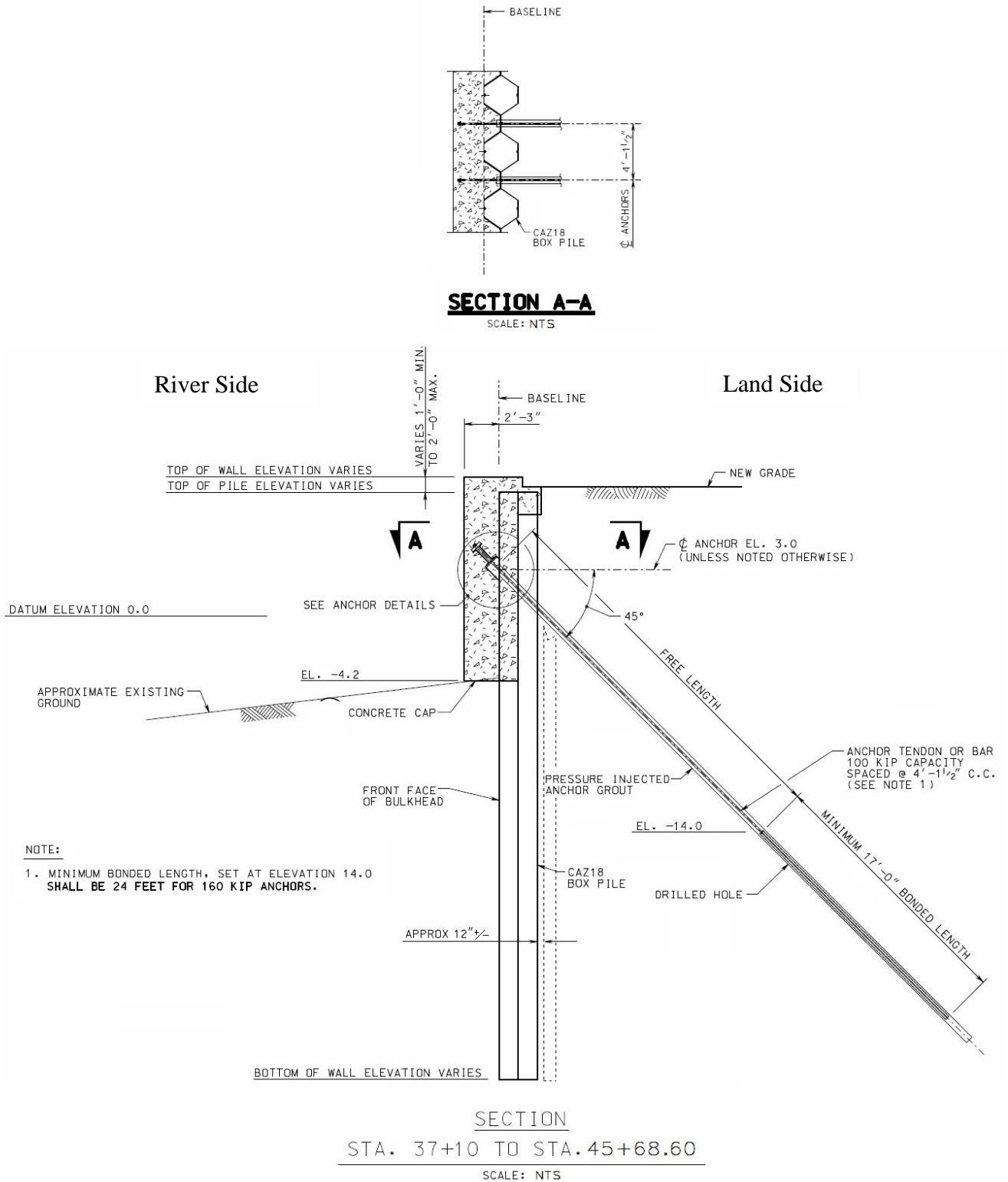

**Figure 18: Re-evaluated Design of Typical Section (Station 37+10 to Station 45+68.60)**



#### **7.4 Railings and Ladders**

Basic railing designs were also developed to provide a boundary between the pedestrians and the river. The railings will be installed along the bulkhead from Station 0+00 to Station 57+80.10. Shop drawings for the railings will be per the latest AASTHO and IBC Code and provided by the contractor. Additional to the railings, access ladders were designed per OSHA Standard 1910.27. The access ladders shall be installed along the bulkhead at Stations 0+00, 9+10, 20+08, 37+05, 45+74, and 57+75. Additional ladders can be added to accommodate the needs of the community.

## 8.0 Climate Change Adaptation

### 8.1 Comprehensive Evaluation of Projects with Respect to Sea Level Change

Sea Level Change (SLC) is the combined effect of the eustatic (i.e. global average) sea level increase due to global warming trend and the land movement in the region. The New Jersey coastline is one of the areas experiencing land subsidence due to geologic process; therefore, the net relative sea level change at the project area is higher than the eustatic SLC. The future SLC for the project area is estimated based on the National Research Council (NRC) and Intergovernmental Panel for Climate Change (IPCC) estimates of eustatic SLC and corrected to include the local land subsidence. Both the historic SLC trend and the future accelerated rate are identified and used for planning, design, sensitivity and risk & uncertainty analysis if required.

### 8.2 SLC Guidance

In October 2011, USACE published guidance to incorporate sea-level change for project planning and design (EC1165-2-212). This SLC guidance has since been expired and replaced with ER 1100-2-8162 (Feb.2014) and ETL 1100-2-1 (Dec.2014). The most recent guidance recommends both the National Research Council report (NRC, 1987) and the Intergovernmental Panel for Climate Change report (IPCC, 2007) findings for prediction of future sea level change. The recommendations are summarized as follows:

1) An extrapolation of the historic rate of local mean-sea-level rise shall be used as the low rate of sea level change for analysis, design, and evaluation;

2) Estimate the intermediate rate of local mean sea-level change using the modified NRC Curve I and NRC equations 2 and 3, and add those to the local rate of vertical land movement.

$$E(t) = 0.0017t + bt_2 \quad (\text{NRC Equation 2})$$

$$E(t_2) - E(t_1) = 0.0017(t_2 - t_1) + b(t_2^2 - t_1^2) \quad (\text{NRC Equation 3})$$

3) An upper (high) rate of local sea level change shall be estimated by considering the modified NRC Curve III value, and combining these numbers with the local rate of vertical land movement. This scenario of high rate of local mean sea level rise exceeds the upper bounds of the IPCC estimates from both the 2001 and 2007 and also includes additional sea-level rise to accommodate the potential for rapid loss of ice from Antarctica and Greenland;

4) The sensitivity, risk, and uncertainty analysis were not conducted since it is not required for this designed and authorized project.

### 8.3 Sea Level Change Calculator

The local SLC chart and curve are calculated based on the online calculator provided by USACE. Both the USACE and NOAA curves and charts are calculated and presented in this report. The link to the online calculator is shown below:

<http://www.corpsclimate.us/ccaceslcurves.cfm>

[EC 1165-2-212](#) and its successor [ER 1100-2-8162](#) were developed with the assistance of coastal scientists from the NOAA National Ocean Service and the US Geological Survey. Their participation on the USACE team allows rapid infusion of science into engineering guidance. [ETL 1100-2-1](#), Procedures to Evaluate Sea Level Change: Impacts, Responses, and Adaptation.

- a) The rate for the "USACE Low Curve" is based on [EC 1165-2-212](#) and its successor [ER 1100-2-8162](#). Use the historic rate of sea-level change as [ETL 1100-2-1](#), Procedures to Evaluate Sea Level Change: Impacts, Responses, and Adaptation. The historic rate used for this project is shown in the figure below:

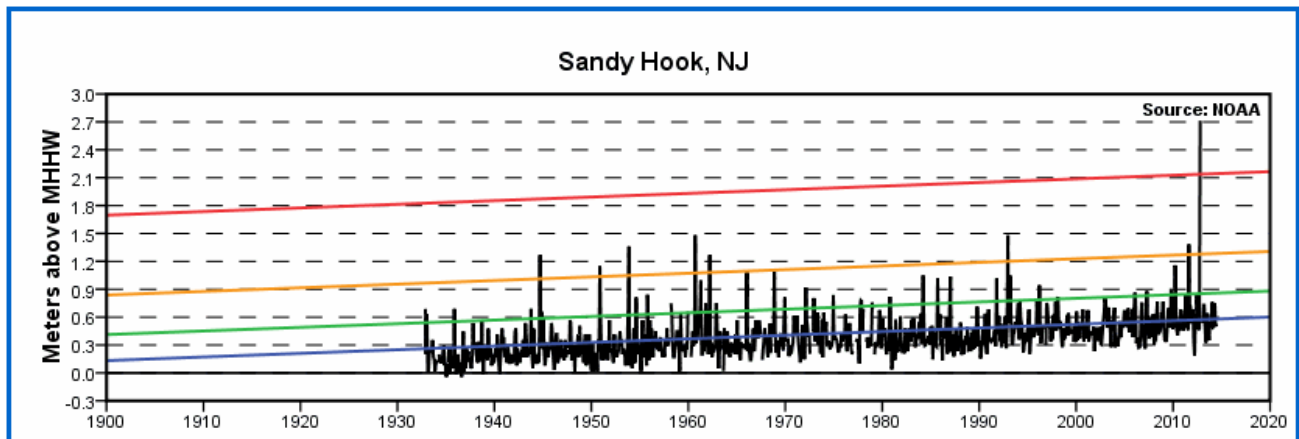

**Figure 19: Historic SLC Rate at Sandy Hook, NJ**

- b) The rate for the "USACE Intermediate Curve" is computed from the modified NRC Curve I considering both the most recent IPCC projections and modified NRC projections with the local rate of vertical land movement added.

- c) The rate for the "USACE High Curve" is computed from the modified NRC Curve III considering both the most recent IPCC projections and modified NRC projections with the local rate of vertical land movement added.

The three scenarios proposed by the NRC result in global eustatic sea-level rise values, by the year 2100, of 0.5 meters, 1.0 meters, and 1.5 meters. Adjusting the equation to include the historic GMSL change rate of 1.7 mm/year and the start date of 1992 (which corresponds to the midpoint of the current National Tidal Datum Epoch of 1983-2001), instead of 1986 (the start date used by the NRC), results in updated values for the coefficients (b) being equal to 2.71E-5 for modified NRC Curve I, 7.00E-5 for modified NRC Curve II, and 1.13E-4 for modified NRC Curve III.

The three local relative sea level change scenarios updated from [EC 1165-2-212](#) (and its successor [ER 1100-2-8162](#), Equation 2) are depicted in the figure to the right of the table in the SLC calculator. A link to an Excel version of the calculator is below the table. The Excel version has a drop-down menu to select tide gauges. Below that is a direct link to the NOAA Tides and Currents web site for the selected tide gauge. [ETL 1100-2-1](#), Procedures to Evaluate Sea Level Change: Impacts, Responses, and Adaptation.

*[EC 1165-2-212, Equation 2:  \$E\(t\) = 0.0017t + bt^2\$](#)*

This on-line Sea Level Change Calculator has several added features which are detailed in the [User's Manual](#). You can plot both the USACE and NOAA curves in feet or meters relative to either NAVD88 or LMSL. The [NPCC2013](#) projections for New York City are also available when the NOAA gauge, "The Battery" is selected. This calculator also develops the SLC curves between the user entered dates using equation #3 in [ER 1100-2-8162](#)

#### **8.4 Local Calculated SLC Results**

The local SLC chart and curves for both USACE and NOAA rates for year 2000 to 2100 in 5-year interval are estimated based on the on-line calculator and shown in Figure 20.

#### **8.5 SLC Impact on Project**

The impact of SLC on the function of the project is reduced level of protection due to accelerated rate of sea level change. Based on USACE low (historical), intermediate, and high projection, the 100 year Sea Level Change varies from 1.1 to 2.2 and 5.5 water level rise. For a typical 500 year flood protection level, the level of protection will reduce to approximately 50 to 100 year correspondingly. A more detailed storm surge frequency analysis for the project site may be performed for mitigation planning in response to sea level changes.

Minish Park, NJ  
 8531680, Sandy Hook, NJ  
 NOAA's Published Rate: 0.01280 feet/yr  
 All values are expressed in feet relative to NAVD88

Year	USACE Low NOAA Low	USACE Int NOAA Int Low	NOAA Int High	USACE High	NOAA High
2000	-0.14	-0.13	-0.12	-0.11	-0.10
2005	-0.07	-0.06	-0.03	-0.01	0.01
2010	-0.01	0.02	0.08	0.11	0.16
2015	0.05	0.10	0.21	0.25	0.32
2020	0.12	0.19	0.34	0.41	0.52
2025	0.18	0.28	0.49	0.59	0.74
2030	0.25	0.37	0.66	0.78	0.98
2035	0.31	0.47	0.84	1.00	1.25
2040	0.37	0.58	1.03	1.23	1.55
2045	0.44	0.69	1.24	1.48	1.87
2050	0.50	0.80	1.46	1.75	2.22
2055	0.57	0.92	1.70	2.04	2.59
2060	0.63	1.04	1.95	2.34	2.99
2065	0.69	1.17	2.22	2.67	3.42
2070	0.76	1.30	2.50	3.01	3.87
2075	0.82	1.43	2.79	3.38	4.34
2080	0.89	1.57	3.10	3.76	4.84
2085	0.95	1.72	3.42	4.16	5.37
2090	1.01	1.87	3.76	4.57	5.92
2095	1.08	2.02	4.11	5.01	6.50
2100	1.14	2.18	4.47	5.47	7.10

[Print Table](#)

Minish Park, NJ  
 8531680, Sandy Hook, NJ  
 NOAA's Published Rate: 0.01280 feet/yr

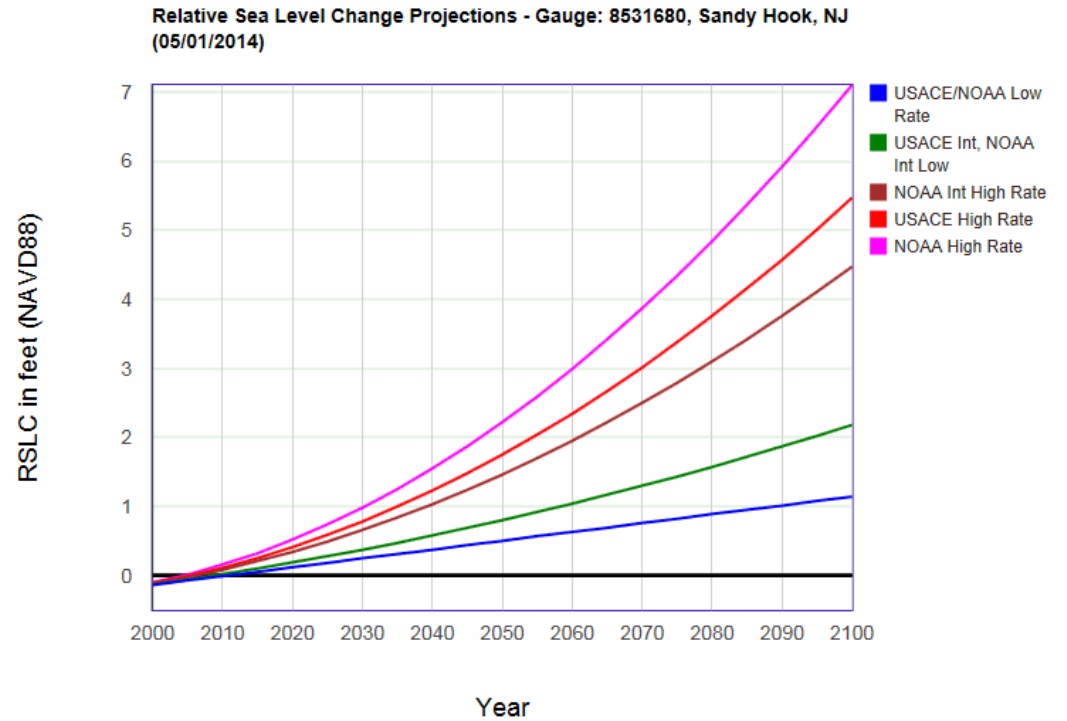

Figure 20: Local Calculated SLC Rate at Minish Park, NJ