

JT's Strong Arm Jack Stabilizer™ Travel Trailer



By



Installation Instructions

**JT's Strong Arm Jack Stabilizers™ are protected under
US patent laws by patent number: # 7,188,842.**

**All material contained herein is proprietary and the sole property of JT's RV Accessories, LLC.
The materials contained herein are protected by copyright law and may not be reproduced in any manner without the written
permission of JT's RV Accessories, LLC. Copyright © 2007. All rights reserved.**

Dear JT's RV Accessories Customer:

Congratulations on your purchase and welcome to the world of JT's RV Accessories! You're now part of the growing number of people who enjoy the ease of use and enhanced comfort and stability they get from using the original, patented JT's Strong Arm Jack Stabilizer™ system on their Fifth-wheel or Travel Trailer.

We build quality and value into every accessory that we produce and JT's Strong Arm Jack Stabilizers are no exception. JT's Strong Arm Jack Stabilizer system will provide you with years of trouble free use and you'll really come to appreciate the many benefits it provides, such as:

- A Rock Steady RV!
- Tremendous time saver!
- One-time permanent installation
- Nothing to tear down or stow away!
- Enhanced Comfort and Stability for your RV lifestyle!
- Easy to set-up: telescopes into place when jacks are lowered-all you do is twist the "T"!

We'd love to hear about your experience with JT's Strong Arm Jack Stabilizer system, and how it has enhanced your RV's comfort and stability.

If you should ever have any questions or problems, feel free to give us a call. We're here to help you from 9 AM to 5 PM Monday through Friday with the knowledge and experience to answer any technical questions you may have. Thanks again and happy RVing!

Kind regards,

Don Payne
Product Manager

JT's RV Accessories-*Enhanced Comfort and Stability for your RV Lifestyle*

www.happijac.com

Corporate Offices: 801-544-2585

PS: JT's RV Accessories is proud to announce the debut of three new products for 2007: JT's LVL-1 Wireless Digital Level™, JT's Elephant Foot Jack Pads and Shoes™ and JT's "T"-Handler™ - a helpful wrench for reaching the "T"-bolts on JT's Strong Arm Jack Stabilizer system.

Please see the home page of our website for more details on these new innovative products. Just choose the tab labeled **Our Products** and make your choice.

TABLE OF CONTENTS

SECTION	DESCRIPTION	PAGE NUMBER
1.	Kit Identification / Product Inventory List	3-6
2.	Parts Line Drawings	7
3.	Tool List	8
4.	Planning the Installation: Travel Trailer:	9
5.	Installation Instructions: Travel Trailer: Front Swing-bolts.	10
6.	Installation Instructions: Travel Trailer: Front Strong Arm Jack Stabilizer™ tubes: Side-to-Side.	11-13
7	Installation instructions -Travel Trailer - Upper, Front-To- Rear, Chassis Stabilizer Mounts.	14-17
8.	Installation Instructions -Travel Trailer – Front Strong Arm Jack Stabilizer™ tubes-Front-To-Rear, Stabilizer Tubes.	17
9.	Installation Instructions -Travel Trailer – Rear Strong Arm Jack Stabilizer™ tubes: Side-To-Side.	18-19
10.	Installation instructions: Rear, Upper Side-To-Side, Chassis Stabilizer Mounts.	20-23
11.	Set-Up Instructions	24
12.	Trouble Shooting	24
13.	Warranty	25
14.	Installation Drawings	26-27

1. Travel Trailer Kit Identification / Product Inventory List

Item Number	Part Number	Kit #	Part Description
		SJS-200S/T Quantity Per Kit	
1.	NLN-5021 118044	30	“Nylock” Nut 3/8”-16
2.	SAEW-5031 119075	48	Washer 3/8” SAE
3.	G5-5001 135835	18	Bolt 3/8” 16 x 1½”
4.	SJS-3001 196226	6	Swing-bolt 3/8” x 1¼”
6.	SJS-3003 196227	6	Swing-bolt 3/8” x 4”
7.	SJS-3007 196234	6	“T”- Bolt
8.	SJS-3009 196240	6	Stiffening Pad
9.	STB-5010 196235	8	Bolt 3/8”-16 x 1” (self-tapping)
10.	SJS-4011 196229	4	Spacer Mount
11.	SJS-4003 196231	6	Stabilizer Outer 1¼” O.D.
12.	SJS-4004 196232	6	Stabilizer Inner 1” O.D.
13.	NLN-5022 191019	6	3/8”- 16 Half Nut

Please match parts and corresponding item numbers on the following pages with the item numbers listed above.

Parts Inventory

SJS-3008 (Fifth wheel kits only)
196225



NLN-5021
118044

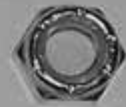

SAEW-5031
119075



G5-5001
135835



SJS-3001
196226

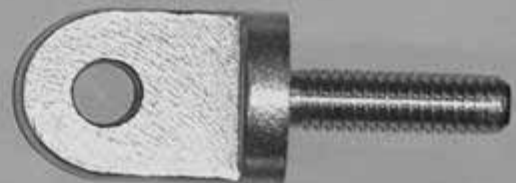

SJS-3003
196227



SBJN-5002
(Fifth wheel kits only)
191019

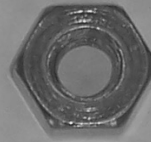

SBLH-100
(Fifth wheel kits only)
196228

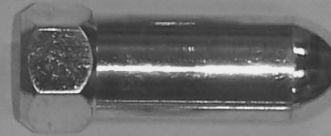

SJS-3007
196234

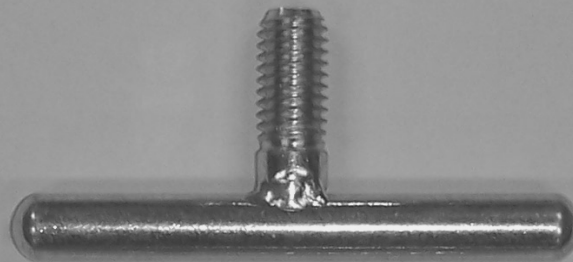

SJS-3009
196240

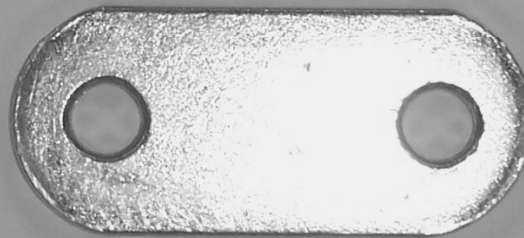

STB-5010
196235

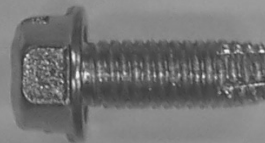

SJS-4011
196229

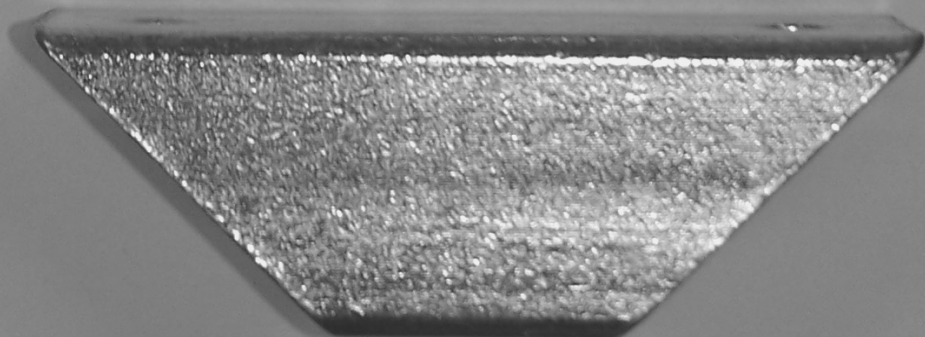



**SJS-2002
(Fifth wheel kits only)
196230**

**SJS-4003 and SJS-4004
196232 196231**

2. Parts Line Drawings

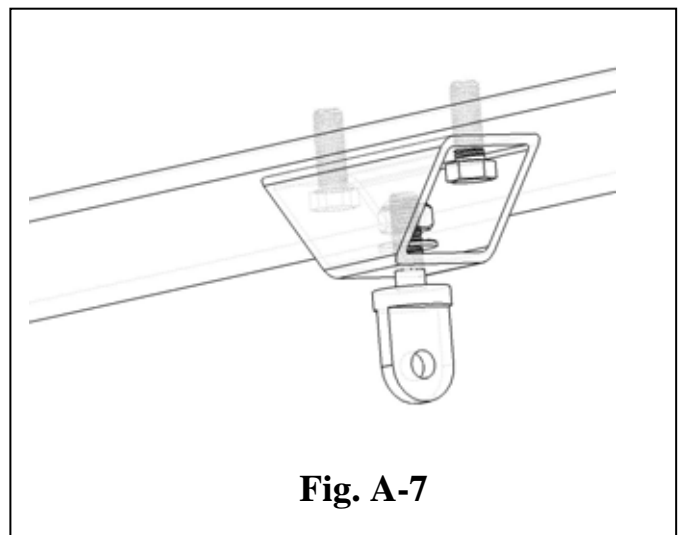
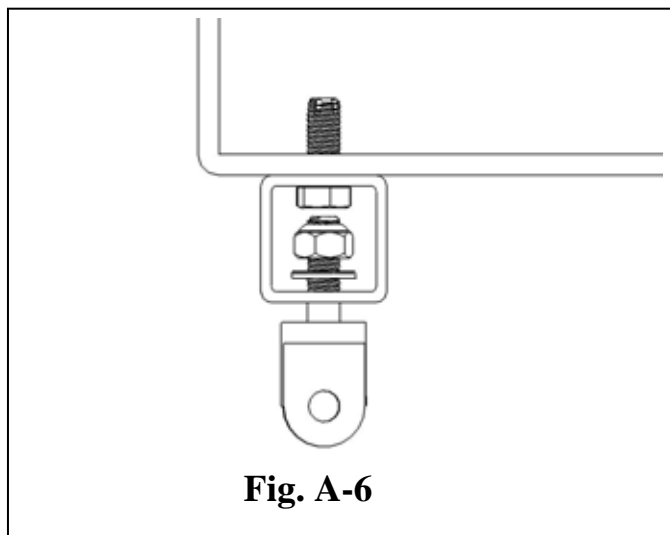
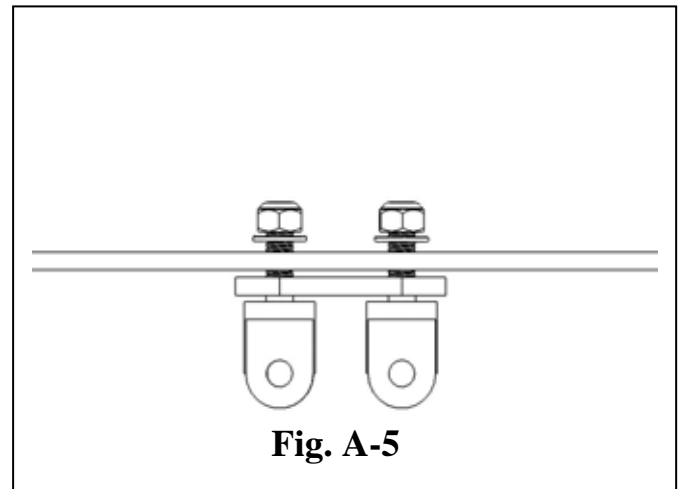
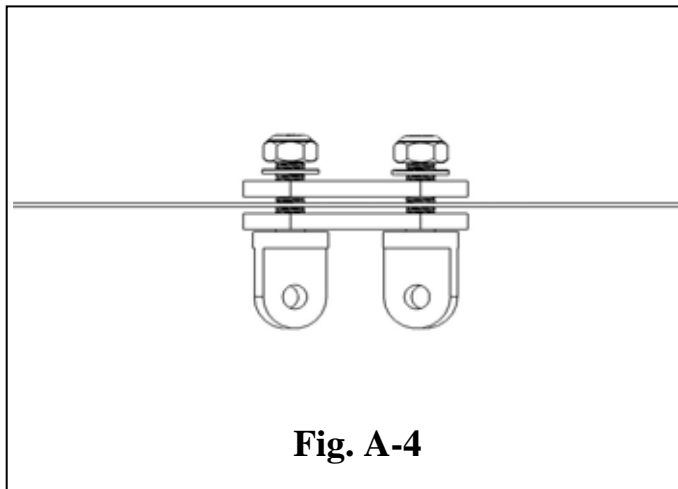
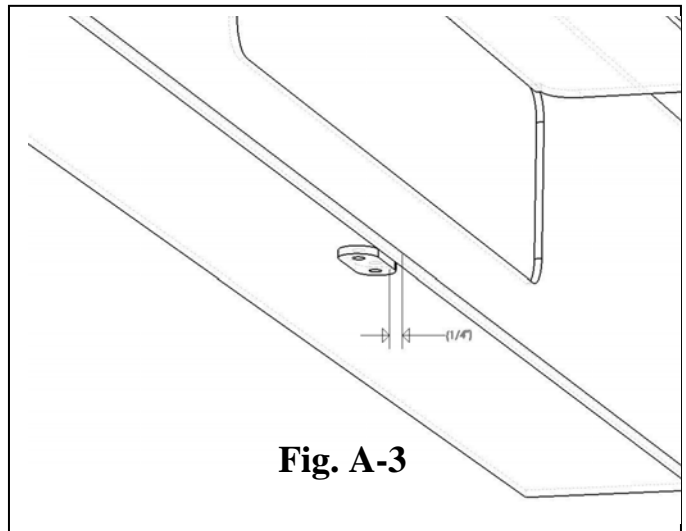
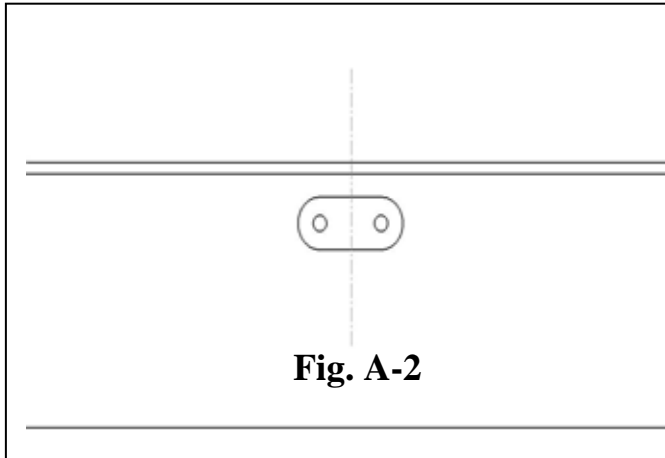

3. Tool List

1. Tape Measure
2. “Sharpie” felt tip black marker or equivalent
3. Hammer
4. Center punch
5. Drill Motor
6. 1/8” drill bit (for pilot holes)
7. 5/16” drill bit
8. 3/8” drill bit
9. 1/2” “Uni-bit” or step drill is preferred- but a standard 1/2” drill bit is OK
10. Counter sink for deburring
11. 9/16” deep socket and ratchet
12. 9/16” box end wrench
13. 5/8” box end wrench
14. 11/16” box end wrench
15. “Vise-Grips”
16. 3”- 4” “C”-Clamp
17. White grease
18. Safety glasses
19. Face shield
20. Mat to lay on
21. Patience!



The Original Patented
JT's Strong Arm Jack Stabilizer™ Kit
(Each kit contains 6 Stabilizers)

4. Planning the Installation - Travel Trailer

- A. Look under the front half of your coach and locate the two main frame rails.
Note: Most coaches manufactured today are insulated underneath and the insulation tends to cover the frame rails. One easy way to locate the frame is to see where the front spring from the axle is mounted to the frame, and follow the rail forward. Also, the manufacturers mount the insulation skin to the frame, so you may see a line of screws going down the frame.
- B. Locate a cross-member 6”-18” in front of the front scissor jacks on the coach. If there is no cross member, there is sometimes a center compartment with a steel floor forward of the front jacks. If there is such a compartment, that will work fine. You will find the Strong Arm Jack Stabilizer kit to be very versatile in mounting. If you cannot find a cross member, or do not have a front compartment with a steel floor, it is not the end of the world. Call our phone # 1-801-544-2585 8AM to 5PM MST and we can help solve any problem you may encounter.
- C. Go to the back half of the coach and locate the rear leveling jacks. Determine the style of jacks you have: Telescoping or Scissor are most common.



**Single-Arm
“C” Type
Telescoping jack**



Scissor jack

- D. Locate a cross-member behind the rear jacks - preferably a minimum distance of 4 inches and a maximum of 18, *if jacks are angled*, and a minimum distance of 6 inches if the jacks are straight. **Again, if you have any problems locating a cross member, or have any questions, please call us at: 1-801-544-2585 8AM to 5 PM MST and we can help solve any problem you may encounter.**
- E. Once you have located all the mounting areas, then you are ready to proceed with the Travel Trailer Installation Instructions, item # 14. JT’s Strong Arm Jack Stabilizers have been mounted successfully on 99% of all makes of coaches. **Remember, if you have any trouble locating any of the mounting points in the items listed above, please call our tech support line 1-801-544-2585 8AM to 5PM MST and we can help solve any problem you may encounter.** We will be glad to walk you through any part of the procedure.

5. Installation Instructions – Travel Trailer – Front Swing-Bolts – Scissor Jacks or Telescoping Jacks.

Once you have planned your installation you are ready to proceed. For the next step you will need the following parts: (Quantities required will vary).

1. 3/8" x 4" swing-bolt, part # SJS-3002. 196227
2. 3/8" washers, part # SAEW-5031. 119075
3. 3/8"-16 "Nylock" nuts, part # NLN-5021. 118044

- A. Choose a side in the front. Beginning with the first scissor jacks, remove the existing lower *inside* pivot bolt. After removing the pivot bolt, insert a 4" swing-bolt from front-to-back with the shoulder of the swing-bolt facing toward the front of the coach. If your trailer is equipped with telescoping jacks remove the landing pad pivot bolt and insert a 4" swing-bolt with the tab facing towards the *rear* of the trailer as shown below right.



Scissor Jacks

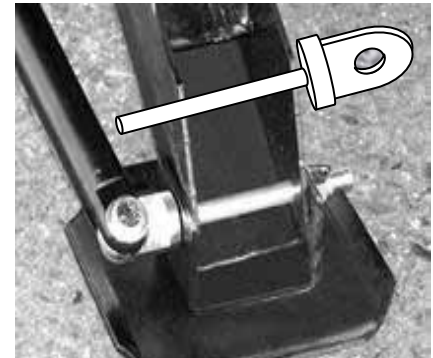

Telescoping with landing pad swing-bolt installed – drawing illustrates approximate location of 2nd swing-bolt

- B. Place a SAE washer over the threaded end of the swing-bolt and a Nylock nut. (use 1/2 Nylock nut for telescoping jacks) Tighten tight enough so that the leverage from a screw driver must be used to pivot the swing-bolt. Make sure to align swing-bolt tab horizontally to accommodate installation of Strong-Arm Jack Stabilizer tube.
- C. For scissor jacks, remove the lower existing *outside* pivot bolt. After removing the lower *outside* pivot bolt, insert a 4" swing-bolt from back-to-front with the shoulder of the swing-bolt looking toward the *rear* of the trailer. If your trailer is equipped with telescoping jacks there will only be one bolt to remove. You'll need to add a second. Here's how. Drill a 3/8" hole on the arm of the jack, 1" in on the arm from bolt that you've just installed. Drill all the way through the arm of the jack. Insert another 4" swing-bolt facing the *opposite* direction from the first one you installed with the shoulder of the swing-bolt facing towards the *front* of the trailer. See above "Right" drawing and refer to "Installation Drawings" for more views.
- D. Place a SAE washer over the threaded end of the swing-bolt and a Nylock nut. (use 1/2 Nylock nut for telescoping jacks) Tighten tight enough so that the leverage from a screw driver must be used to pivot the swing-bolt.
- E. Repeat steps A-E for the opposite front side.

6. Installation Instructions – Travel Trailer – Front Strong Arm Jack Stabilizer tubes – Side-To-Side.

For the next step you will need the following parts: (Quantities required will vary).

1. 3/8" washers, part # SAEW-5031. 119075
2. 3/8"-16 x 1 1/2" bolts, part # G5-5001 135835
3. 3/8"-16 "Nylock" nuts, part # NLN-5021. 118044
4. "T"-bolts part # SJS – 3007. 196234
5. Strong Arm Jack Stabilizer tubes: outer and inner.
Part #s SJS - 4003 196231 and 4004 196231.
6. 3/8" x 1 1/4" swing-bolt, part # SJS-3001 196232
7. Spacer mount, part # SJS-4011 196229

JT's Strong Arm Jack Stabilizers properly installed on front scissor jacks



See "Installation Drawings" for more views.

- A. Get two "T"-bolts and apply white grease to the first few threads and insert into the threaded "spud" of the outer Strong Arm Jack Stabilizer tubes. Note: Be sure when choosing Strong Arm Jack Stabilizer tubes that you get the correct sides-there is a left and a right-you will need one of each. IE: The warning label should face outward so that the label is visible and is right side up and able to be read. The "T"-bolts must be on the top side of the tube.



6. Continued

- B. Remove Strong Arm Jack Stabilizer inner tube from outer tube and remove plastic bag. Reinsert inner tube fully (minus the bag) and then pull out 1 inch of inner tube and snug the “T”-bolt so that the tube does not slide. Align the slot of the clevis-end 90 degrees to the “T”-bolt so that it is horizontal and ready to fit properly over the end of the swing-bolt that you’ve just installed onto the scissor jack. Repeat this process for both the left and right Strong Arm Jack Stabilizer tubes prior to crawling back under the coach...it is much easier now!
- C. Before beginning this step fully retract the jacks. Take one 3/8”-16 x 1½” bolt, and place a washer on it and have a second washer and one locknut in hand and ready. Now take one of the Strong Arm Jack Stabilizer units and place the smaller end (inner tube end) onto the swing-bolt tab that you’ve installed on the scissor jack, making sure that the warning label is right side up (as mentioned above) and insert bolt through the hole in the clevis end of the tube from the top down with the threads of the bolt going down towards the ground. When installed correctly, the “T”-bolts will be on the top side of the Strong Arm Jack Stabilizer tube. Place the second washer on the bolt and then put on the locking nut and tighten.
- D. Repeat this procedure (steps A-C) on each of the front scissor jacks.
- E. Insert a swing-bolt into the hole in the spacer mount, leaving only a couple of threads on the inside showing. Slide a washer onto the swing-bolt on the inside, then put a 3/8 inch nut on over the washer (see Fig. A-6 page 7). You will have to use a 9/16 inch box-end wrench to tighten the nut. Make sure to slide the open end part of the wrench onto the nut inside the spacer mount, then put a screw driver, or a center punch, through the hole in the swing-bolt and rotate to the right and tighten. It is much easier to install the swing-bolts in the spacer mounts off the coach than it is when they are on the coach. Do both swing-bolts and spacer mounts.
- F. Take one of the 3/8”-16 x 1½” bolts, put a washer on it and keep it ready in-hand. Take one swing-bolt / spacer mount assembly (that you just made in step “E”) and slide the swing-bolt tab into the clevis-end of the Strong Arm Jack Stabilizer tube and secure with the 3/8”-16 x 1½” bolt. Put a second washer and a lock nut on and tighten enough so that you can still swivel the swing-bolt assembly by hand with some resistance.
- G. Rotate the Strong Arm Jack Stabilizer tube inward toward the center of the coach, and upward to the cross-member, with the spacer mount assembly facing upward, with the long side of the spacer mount running parallel with the cross-member to which it will be attached.

6. Continued



Note: Be sure the narrow dimension of the spacer mount is centered front-to-back on the cross-member so that the holes are centered on the cross member. The long dimension of the spacer mount must be parallel with the cross-member side-to-side.

- H. While holding the spacer mount up tightly against the cross-member, mark both holes. Slide Strong Arm Jack Stabilizer tube assembly out of the way and center punch the two holes. If the insulation is the plastic corrugated type it's okay to punch through it. When the mounts are installed they will install over the top of it.
- I. Drill 1/8" pilot holes through the punch marks in both holes.
- J. Drill one of the holes out to 5/16".
- K. You will need two 3/8"-16 x 1 inch self-tapping bolts, part # STB-5010 in the kit. Take one of the self-tapping bolts and pre-tap the 5/16 inch hole. A 9/16 inch deep socket and ratchet wrench should work fine to do the job. If you can't put enough upward pressure to get the self-tapping bolt to start, then use a 3/8" – 16 tap. It also helps to use a drop of oil on the thread before starting to tap the hole. Note: if you've used the self-tapping bolt to pre-tap the hole, you must remove it before proceeding to the next step.
- L. Rotate the Strong Arm Jack Stabilizer assembly with spacer mount back to the bottom side of the cross member, where you just tapped the hole and realign the holes. Insert the self-tapping bolt back through the spacer mount and into the hole that was just pre-tapped and tighten it. While tightening the bolt, but sure to keep the spacer mount centered over the remaining 1/8" pilot hole.
- M. Drill the remaining 1/8" pilot hole out to 5/16".
- N. Insert second self-tapping bolt and tighten (See fig. A-7)
- O. Repeat steps E-N for opposite side.

7. Installation instructions -Travel Trailer - Upper, Front-To-Rear, Chassis Stabilizer Mounts.

Now that you have completed section 6, you are ready to install the upper, front-to rear, stabilizer mounts located on the left and rights sides of the coach.

If the two main frame rails that run the length of the coach (front-to-back), are made of a wide flange or “H” beam or “I” beam style of frame material, and if the frame is *uninsulated*,

Refer to:-----Section 7-1.

If the two main frame rails that run the length of the coach (front-to-back) are made of a wide flange, or “H” beam, or “I” beam style of frame material, and if the frame is *insulated* and / or if the frame is made of rectangular tubing,

Refer to:-----Section 7-2.

Once you have completed the section (listed above) that applies to your coach, please proceed to section 8.

7-1. Uninsulated. The two main frame rails that run the length of the coach (front-to-back) are made of a wide flange, or “H” beam, or “I” beam style of frame material, and the frame is *uninsulated*. For the next step you will need the following parts: (Quantities required will vary).

1. Stiffening pad SJS-3009. 196240
2. 3/8” x 1¼” Swing-bolts, part # SJS-3001. 196226
3. 3/8” washers, part # SAEW-5031. 119075
4. 3/8”-16 “Nylock” nuts, part # NLN-5021. 118044

- A. Choose one of the two sides and measure from the back side of the scissor jack, 30 inches toward the rear of the coach, on the bottom side of the frame rail, and make a mark across the frame. This will be your center line for the swing-bolt.
- B. Stiffening pad, part #SJS-3009 196240, is now needed. Measure the width of the bottom side of the frame rail flange, and divide by four. This will give you the location of the center line of the hole that you will be drilling for the swing-bolt. For example, if the measurement of the bottom flange is 4 inches, dividing that by 4 gives you the dimension that will be used for the center hole of the swing-bolt. In this example, that would be 1 inch from the outside edge of the flange.

7-1. Continued

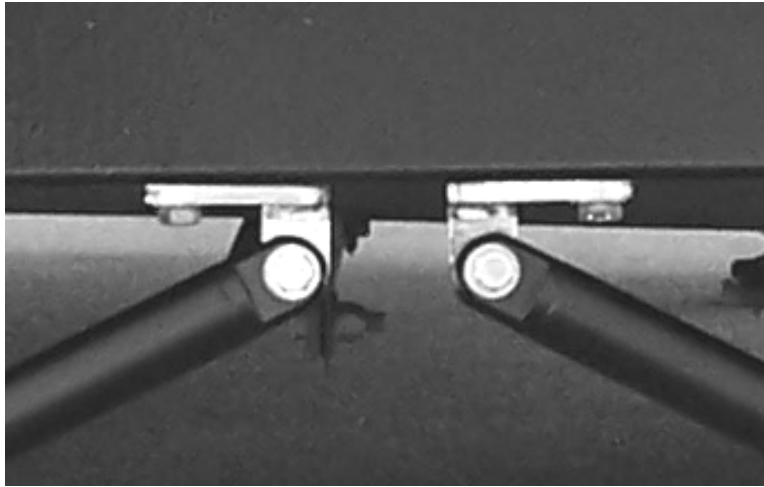

- C. Make a punch mark at the two intersecting lines. Line 1 is the 30 inch line that was drawn in step “A” above. Line 2 will be the point that was determined to be one fourth of the width of the flange (from the outside edge) as determined in step “B” above.
- D. Drill a 1/8 inch pilot hole through the punch mark that was determined in step “C” above.
- E. Now drill the 1/8 inch pilot hole out to 3/8 inch diameter. Make sure to deburr the hole.
- F. Using the stiffening pad, and a 3/8 x1¼ inch swing-bolt, part #SJS-3001 196226; from the bottom, insert the swing-bolt through the stiffening pad and into the hole that you just drilled through the frame. Install a washer, part #SAEW-5031 119075, over the bolt threads then a 3/8-16 “Nylock nut, part #NLN-5021 118044, and tighten. Make sure that the stiffening pad is running parallel with the edge of the frame; front-to-back.
- G. Repeat steps A-F on the other frame on the opposite side of the coach.
- H. Now you have created a template to drill the second 3/8 inch hole through each of the frame rails. Drill both holes (both sides of the coach) through the frame, through the stiffening pads, to 3/8 inch and deburr.
- I. Put a washer on each bolt. From the bottom up, insert bolt through stiffening pad, up through the frame. Put another washer on the bolt after it goes through the frame and then the lock nut. Tighten the lock nut.
- J. Repeat step “I” for the opposite side.

Now that you have completed the section that applies to your coach, please proceed to section 8.

7-2. Insulated. The two main frame rails that run the length of the coach (front-to-back) are made of a wide flange, or “H” beam, or “I” beam style of frame material, and the frame is *insulated* and or the frame is made of rectangular tubing. For the next step you will need the following parts: (Quantities required will vary).

1. Spacer mounts, part # SJS-4011 196229.
 2. 3/8” x 1¼ inch swing-bolts, part # SJS-3001 196226.
 3. 3/8” washers, part # SAEW-5031 119075.
 4. 3/8”-16 “Nylock” nuts, part # NLN-5021 118044.
- A. Choose one of the two sides and measure from the back side of the scissor jack, 27¾ inches, toward the rear of the coach. On the insulation (bottom side of the frame rail), make a mark with a “Sharpie” felt-tip marker at the dimension above.
- B. Insert a swing-bolt into the hole in the spacer mount, leaving only a couple of threads on the inside showing. Slide a washer onto the swing-bolt on the inside, then put a 3/8 inch nut on over the washer (see Fig. A-6 page 7). You will have to use a 9/16 inch box end wrench to tighten the nut. Make sure to slide the open end part of the wrench onto the nut inside the spacer mount, then put a screw driver, or a center punch through the hole in the swing-bolt and rotate to the right and tighten. It is much easier to install the swing-bolts in the spacer mounts off the coach than it is when they are on the coach. Do both swing-bolts and spacer mounts.
- C. Now take one of the spacer mounts and place one edge along the line that you made in step “A” above. Make sure that the spacer mounts run lengthwise, parallel to the outer edge of the frame rail from the front to the rear. The front edge of the spacer mount should be on the line that was marked in step “A” above. Holding the spacer mount in place, mark the location of the holes of the spacer mounts onto the frame rail / insulation with a “Sharpie” felt tip marker.
- D. Center punch the holes that you just marked and drill a 1/8 inch pilot hole through each punch mark. Repeat process on the other side of the coach.
- E. Drill the holes closest to the scissor jack on each side of the travel coach first, to 5/16”.
- F. You will need four 3/8”-16 x 1 inch self-tapping bolts, part # STB-5010 196235. Take one of the self-tapping bolts and pre-tap the two 5/16 inch holes. A 9/16 inch deep socket and ratchet wrench should work fine to do the job. If you can’t put enough upward pressure to get the self-tapping bolt to start, then use a 3/8” -16 tap. It also helps to use a drop of oil on the threads before starting to tap the holes.
- G. Take one of the spacer mounts, and put it up to the bottom side of the frame rail where you just tapped one of the holes. Insert a self-tapping bolt through the spacer mount and screw it into the frame rail and tighten the bolt. As you are tightening the bolt, make sure to center up the hole on the other side of the spacer mount, over the pilot hole, then finish tightening. Repeat on the second spacer mount.
- H. Drill the two 1/8 inch pilot holes centered in the holes in the spacer mounts, to 5/16 inch.

7-2. Continued

- I. Insert the other two self-tapping bolts and tighten (see Fig. A-7). Remember to use a drop of oil on each bolt before tapping. When finished, the swing-bolt on the spacer mount should measure 30 inches from the backside of the scissor jack toward the rear of the coach to the center of the swing-bolt on the spacer mount on both frame rails, on each side of the coach.

Now that you have completed the section that applies to your coach, please proceed to section 8.

8. Installation Instructions -Travel Trailer – Front Strong Arm Jack Stabilizer Tubes: Front-To-Rear.

For the next step you will need the following parts: (Quantities required will vary)

1. 3/8” SAE washers, part # SAEW-5031 119075.
 2. 3/8”-16 “Nylock” nuts, part # NLN-5021 118044.
 3. Strong Arm Jack Stabilizer tubes- outer and inner Parts #s SJS-4003 196231 and 4004 196232.
 4. 3/8” “T”-bolts part # SJS-3007196234.
 5. 3/8”-16 x 1½” bolts, part # G5-5001 135835.
- A. Get two “T”-bolts and apply white grease to the first few threads and insert into the threaded “spud” of the outer Strong Arm Jack Stabilizer tubes. Note: Be sure when choosing Strong Arm Jack Stabilizer tubes that you get the correct sides-there is a left and a right-you will need one of each. NOTE: The warning label should face outward so that the label is visible and is right side up and able to be read. The “T”-bolts must be on the top side of the tube.
 - B. Remove Strong Arm Jack Stabilizer inner tube from outer tube and remove plastic bag. Reinsert inner tube fully (minus the bag) and then pull out 5 inches of inner tube and snug the “T”-bolt so that the tube does not slide. Repeat this process for both the left and right Strong Arm Jack Stabilizer tubes prior to crawling back under the coach...it is much easier now!
 - C. Take one 3/8”-16 x 1½” bolt, and place a washer on it and have a second washer and one locknut in hand and ready. Now take one of the Strong Arm Jack Stabilizer units and slide it into place over the tab of one of the upper swing-bolts. Make sure that the Warning Label is facing towards the outside of the coach and that the “T”-bolts are pointing upwards and towards the front of the coach. Insert the 3/8”-16 x 1½” bolt from the outside towards the inside of the coach. Put the washer on the back side and then the Nylock nut and tighten.
 - D. Taking the inner stabilizer tube, place the clevis-end on the swing-bolt tab that is mounted to the scissor jack. Take one 3/8”-16 x 1½” bolt, put a washer on it and insert it into the clevis from the outside of the coach towards the inside of the coach. Put on a washer and Nylock nut and tighten.
 - E. Repeat steps A-D for the other side of the coach.

9. Installation Instructions -Travel Trailer – Rear Strong Arm Jack Stabilizer Tubes: Side-To-Side.



Now that you have completed section 8 , you are ready to install the swing-bolts and stabilizers on the rear scissor jacks to attain side-to-side stabilization. For the next step you will need the following parts:

1. 3/8"x 4 inch swing-bolts part # SJS-3002 196227.
 2. 3/8" SAE washers, part # SAEW-5031 119075.
 3. 3/8"-16 "Nylock" nuts, part # NLN-5021 118044.
 4. JT's Strong Arm Jack Stabilizer tubes- outer and inner
Parts #s SJS-4003 196231 and 4004 196232.
 5. 3/8" "T"-bolts part # SJS-3007 196234.
 6. 3/8"-16 x 1½" bolts, part # G5-5001 135835.
- A. Choose a side; this procedure will be repeated on both left and right hand scissor jacks. Remove existing bottom outboard pivot bolt on scissor jack and replace with one 3/8"x 4 inch swing-bolt with the shoulder of the swing-bolt facing the rear of the coach. Put on washer, nut and tighten. Tighten the swing-bolt tight enough so that you have to use a screw driver through the hole to make the swing-bolt swivel. Make sure to align swing-bolt tab horizontally to accommodate installation of Strong Arm Jack Stabilizer™ tube.
- B. Get both "T"-bolts and apply white grease to the first few threads and insert into the threaded "spud" of the outer Strong Arm Jack Stabilizer tubes. Note: Be sure when choosing Strong Arm Jack Stabilizer™ tubes that you get the correct sides-there is a left and a right-you will need one of each. i.e.: The warning label should face outward so that the label is visible and is right side up and able to be read. The "T"-bolts must be on the top side of the tube.
- C. Remove Strong Arm Jack Stabilizer inner tube from outer tube and remove plastic bag. Reinsert inner tube fully (minus the bag) and then pull out 1 inch of inner tube and snug the "T"-bolt so that the tube does not slide. Align the slot of the clevis-end 90 degrees to the "T"-bolt so that it is horizontal and ready to fit properly over the end of the swing-bolt that you've just installed onto the scissor jack. Repeat this process for both the left and right Strong Arm Jack Stabilizer tubes prior to crawling back under the coach...it is much easier now!

9. Continued

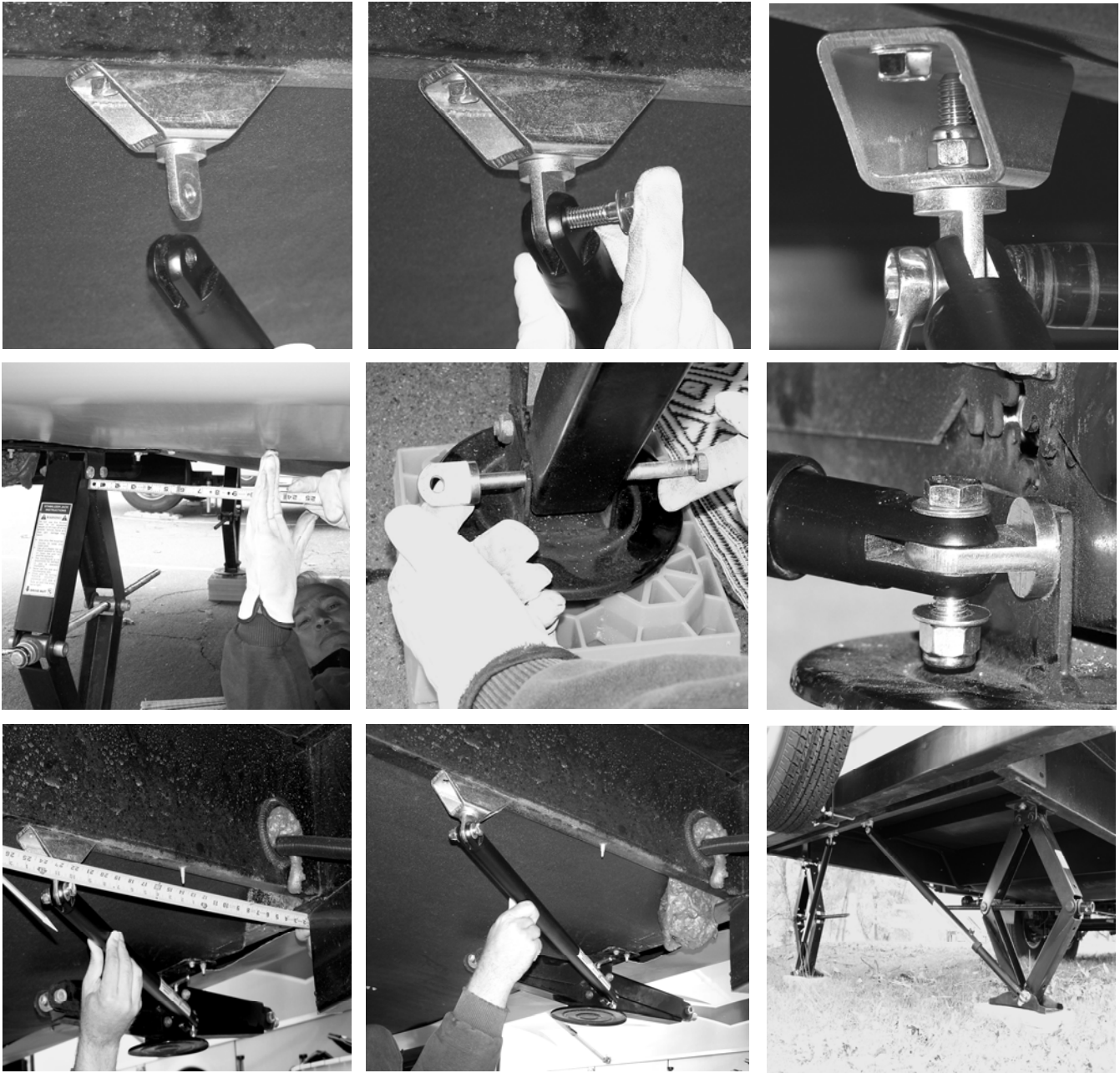

- D. Before beginning this step fully retract the jacks. Take one 3/8"-16 x 1 1/2" bolt, and place a washer on it and have a second washer and one locknut in hand and ready. Now take one of the Strong Arm Jack Stabilizer units and place the smaller end (inner tube end) onto the swing-bolt tab that you've installed on the scissor jack, making sure that the warning label is right side up (as mentioned above) and insert bolt through the hole in the clevis end of the tube from the top down with the threads of the bolt going down towards the ground. When installed correctly, the "T"-bolts will be on the top side of the Strong Arm Jack Stabilizer™ tube. Place the second washer on the bolt and then put on the locking nut and tighten.
- E. Repeat procedure on the other side of the coach.

10. Installation instructions: Rear, Upper Side-To-Side, Chassis Stabilizer Mounts.

Now that you have completed section 19, you are ready to install the unattached end of your Strong Arm Jack Stabilizer™ tube to the chassis. There are two types of cross members that you may encounter, and we will address these two scenarios below.

If the rear cross-member, running from side-to-side, is made of “C”- channel, and if the frame is uninsulated,

Refer to:-----Section 10-1.

If the rear cross-member, running from side-to-side, is made of rectangular tubing or “C”- channel, and if the frame is insulated,

Refer to:-----Section 10-2.

Once you have completed the section (listed above) that applies to your coach, please proceed to section 11.



10-1. The rear cross-member running from side-to-side is made of “C”- channel, and the frame is uninsulated. For this step you will need the following parts:

1. Two 3/8” x 1/4” swing-bolts, part # SJS-3001 196226.
 2. Ten 3/8” SAE Washers, part # SAEW-5031 119075.
 3. Six 3/8”-16 “Nylock” nuts, part # NLN-5021118044.
 4. Two Stiffening Pads, part # SJS-3009 196240.
 5. Two 3/8”-16 x 1 1/2” bolts, part # G5-5001 135835.
- A. Before beginning this step fully retract the jacks. Choose a side; this procedure will be repeated on both left and right hand scissor jacks. Take a 3/8”-16 x 1 1/2” bolt, put a washer on it. Now take a swing-bolt, and insert the tab end into the unattached clevis end of the Strong Arm Jack Stabilizer that was just attached to the scissor jack. Insert the 3/8”-16 x 1 1/2” bolt through the clevis end of the Strong Arm Jack Stabilizer™ tube, and swing-bolt and put a washer and nut on the end. Tighten the nut and align the swing-bolt so that the threaded end is pointing upwards. Tighten the nut and bolt until there is some resistance, but you are still able to swivel the swing-bolt by hand.

10-1. Continued

- B. Rotate the Strong Arm Jack Stabilizer tube inward and upward, toward the center of the coach, until the threaded end of the swing-bolt centers up (front-to-back) on the cross-member to which it will be attached.
- C. On the cross member, mark a line that represents the center line of the swing-bolt. This is the place where the center of the swing-bolt's threaded end intersects the center of the flange of the cross-member, front-to-back.
- D. Take a stiffening pad and place it on the bottom side of the flange of the cross-member, aligning the outside hole of the stiffening pad with the centerline that you just made on the cross-member. The second hole of the stiffening pad will be toward the center of the coach. The stiffening pad should be centered on the cross-member, front-to-back.

Clamp it in place with a pair of vise grips, between the two holes on the stiffening pad, when attaching it to the cross member. This will become a template for drilling the two holes in the cross member.

- E. Rotate the Strong Arm Jack Stabilizer tube out of the way and drill both 3/8" holes through the cross-member, using the stiffening pad as a drilling guide.
- F. With the stiffening pad and vise-grips still in place, take a 3/8"-16 x 1 1/2" bolt, put a washer on it and insert it upwards through the stiffening pad and cross member. Put on a second washer and a locknut and tighten.
- G. Remove vise-grips. Swing the Strong Arm Jack Stabilizer tube back toward the hole and insert the swing-bolt up through the hole that you just drilled through the cross member. Note: this should be the outside hole – the one nearest the outside of the coach. Put a washer on the end of the bolt and then a lock nut and tighten.
- H. Finish tightening the 3/8" nut and bolt holding the Strong Arm Jack Stabilizer onto the swing-bolt that was previously hand tightened –see last comment in step "A" above.
- I. Repeat steps A-H for installation of the other rear Strong Arm Jack Stabilizer on the opposite side of the coach.

Now that you have completed the section that applies to your coach, please proceed to section 11.

10-2. The rear cross-member running from side-to-side is made of rectangular tubing or "C"- channel, and the frame is insulated. For this step you will need the following parts:

1. Two 3/8" x 1 1/4" swing-bolts, part # SJS-3001 196226.
2. Two 3/8"-16 x 1 1/2" bolts, part # G5-5001 135835.
3. Six 3/8" SAE Washers, part # SAEW-5031 119075.
4. Two spacer mounts, part # SJS-4011 196229.
5. Four 3/8" x 1" self-tapping bolts, part # STB-5010 196235.

10-2. Continued

- A. Insert a swing-bolt into the hole in the spacer mount, leaving only a couple of threads on the inside showing. Slide a washer onto the swing-bolt on the inside, then put a 3/8 inch nut on over the washer (see Fig. A-6). You will have to use a 9/16 inch box end wrench to tighten the nut. Make sure to slide the open end part of the wrench onto the nut inside the spacer mount, then put a screw driver, or a center punch, through the hole in the swing-bolt and rotate to the right and tighten. It is much easier to install the swing-bolts in the spacer mounts off the coach than it is when they are on the coach. Do both swing-bolts and spacer mounts.
- B. Before beginning this step fully retract the jacks. Take one of the 3/8"-16 x 1½" bolts, put a washer on it and keep it ready in-hand. Take one swing-bolt / spacer mount assembly (that you just made in step "A") and slide the swing-bolt tab into the clevis-end of the Strong Arm Jack Stabilizer™ tube and secure with the 3/8"-16 x 1½" bolt. Put a second washer and a lock nut on and tighten enough so that you can still swivel the swing-bolt assembly by hand with some resistance.
- C. Rotate JT's Strong Arm Jack Stabilizer tube inward toward the center of the coach, and upward to the cross-member, with the spacer mount assembly facing upward, with the long side of the spacer mount running parallel with the cross-member to which it will be attached. Note: be sure the narrow dimension of the spacer mount is centered front-to-back on the cross-member so that the holes are centered on the cross member. The long dimension of the spacer mount must be parallel with the cross-member side-to-side.
- D. While holding the spacer mount up tightly against the cross-member, mark both holes. Slide Strong Arm Jack Stabilizer™ tube assembly out of the way and center punch the two holes. If the insulation is the plastic corrugated type it's okay to punch through it. When the mounts are installed they will install over the top of it.
- E. Drill 1/8" pilot holes through the punch marks in both holes.
- F. Drill one of the holes out to 5/16".
- G. You will need two 3/8"-16 x 1 inch self-tapping bolts, part # STB-5010 196235 in the kit. Take one of the self-tapping bolts and pre-tap the 5/16 inch hole. A 9/16 inch deep socket and ratchet wrench should work fine to do the job. If you can't put enough upward pressure to get the self-tapping bolt to start, then use a 3/8" – 16 tap. It also helps to use a drop of oil on the thread before starting to tap the hole. Note: if you've used the self-tapping bolt to pre-tap the hole, you must remove it before proceeding to the next step.

10-2. Continued

- H. Rotate JT's Strong Arm Jack Stabilizer assembly with spacer mount back to the bottom side of the cross member, where you just tapped the hole and realign the holes. Insert the self-tapping bolt back through the spacer mount and into the hole that was just pre-tapped and tighten it. While tightening the bolt, but sure to keep the spacer mount centered over the remaining 1/8" pilot hole.
- I. Drill the remaining 1/8" pilot hole out to 5/16".
- J. Insert second self-tapping bolt and tighten (see fig. A-7)
- K. Repeat steps A-J for opposite side.

Now that you have completed the section that applies to your coach, please proceed to section 11.

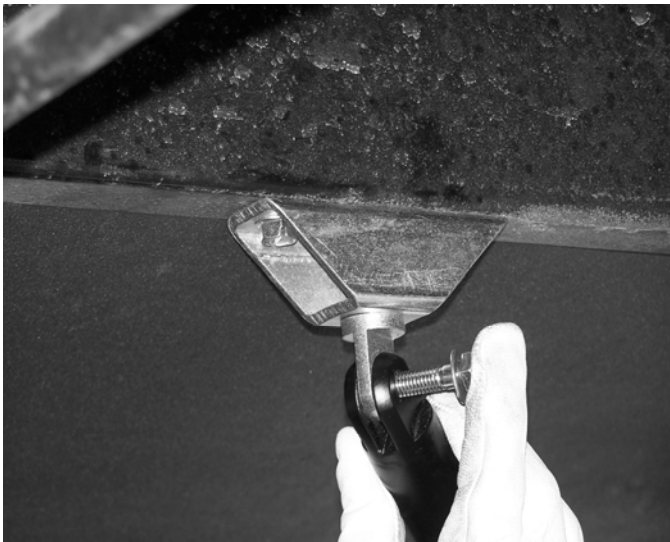

11. JT's Strong Arm Jack Stabilizer system SET-UP INSTRUCTIONS

1. Level your coach side-to-side.
2. Lower the front of the coach 1 inch below level.
3. Lower *rear* jacks to the ground and set evenly.
4. Tighten the "T"-bolts on the 2 rear Strong Arm Jack Stabilizers.
5. Raise the front of the trailer to make it level, front-to-back, using the tongue jack.
6. Lower *front* jacks to the ground and set evenly.
7. Tighten the "T"-bolts on the 4 front Strong Arm Jack Stabilizers.
8. Release some of the pressure or weight off of the tongue jack by retracting it. This puts pressure onto the jacks which are connected to the JT's Strong Arm Jack Stabilizers. This tightens up the stabilization system eliminating the play (movement) at the bolts and bolt holes between the stabilizers and the trailer.
9. Enjoy your Rock-Steady RV from JT's RV Accessories!

12. TROUBLESHOOTING

Sometimes the lay of the land and the type of surface that your coach is setting on may present some challenges for you during setup. The following are some of the most common situations you may encounter and how to deal with them.

1. **Condition:** Setting up on sand, gravel or any type of loose soil conditions, you find that the surface will compress or move overnight causing the leveling jacks to loosen up and allow movement of your coach. You may have to reset after the first night and then again 2-3 days later.
Solution: Place a larger diameter pad (such as a 2" x 12" x 12") between the foot of the jack and the surface and then starting with step 1 on the set-up instructions go back through the set-up process.
2. **Condition:** You've gone through the set-up instructions and the coach still has unwanted movement.
Solution: Check to see that all of the "T"-bolts are tight. Next, push on the front of the coach and see if there is movement at the connection point of the electric jacks and the Strong Arm Jack Stabilizer clevis. If there is, see item #8 on the setup and be sure that you have done this.
3. **Condition:** You've gone through the set-up instructions and the coach still has unwanted movement.
Solution: You've done item two above, and there is still movement. Loosen all "T"-bolts and go back through entire setup making sure that you pay special attention to steps 2-6.



PRODUCT WARRANTY

JT's RV Accessories, (hereinafter referred to as JT's), warrants JT's Strong Arm Jack Stabilizers against manufacturer's defects for two (2) years.

This warranty does not extend to damage to a product or part resulting from accident, misuse, alteration, neglect, abuse, improper installation or normal wear and tear to the exterior appearance and color. This warranty extends only to the original use of the product. Proof of purchase may be required.

If a defect is determined to be present in a product or part within the warranty period, the owner of the product is to contact JT's and report the defect. JT's will determine whether the claimed defect is covered by the warranty.

If the product is determined to be covered by this warranty, JT's will repair or replace, at its option, the product or the defective part. Allow 4-6 weeks for completion of repairs or replacement and return of the product or part. Shipment costs for any replaced parts or products is the responsibility of the consumer and are FOB Kaysville, UT.

If a product or part is replaced, JT's warrants the replacement for the remainder of the original warranty period.

This warranty provides the consumer with specific legal rights and these rights may vary from state to state. JT's does not authorize any person to create for it any other obligation or liability in connection with JT's products.

**JT's Strong Arm Jack Stabilizers™ are Protected under
US patent laws by Patent Number: # 7,188,842**

1-801-544-2585
www.happijac.com

The materials contained herein are protected by copyright law and may not be reproduced in any manner without the written permission of JT's RV Accessories, LLC.
© 2007 JT's RV Accessories, LLC. JT's RV Accessories logo, are trademarks of JT's RV Accessories.
All rights reserved. All material contained herein is proprietary and the sole property of JT's RV Accessories, LLC.
© JT's RV Accessories, LLC. 2007. All rights reserved.

Installation Drawings Travel Trailer

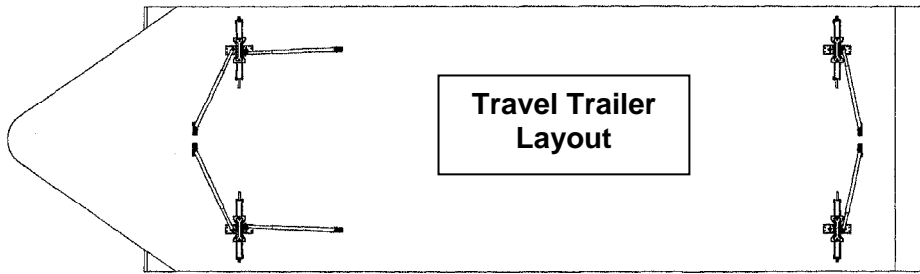

Side View
Left Front Corner

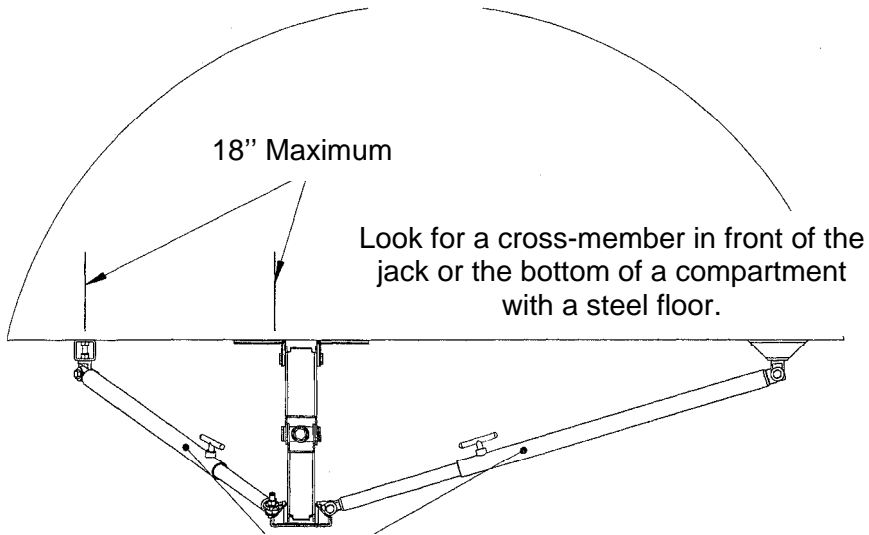

Make sure warning labels are outside and visible.

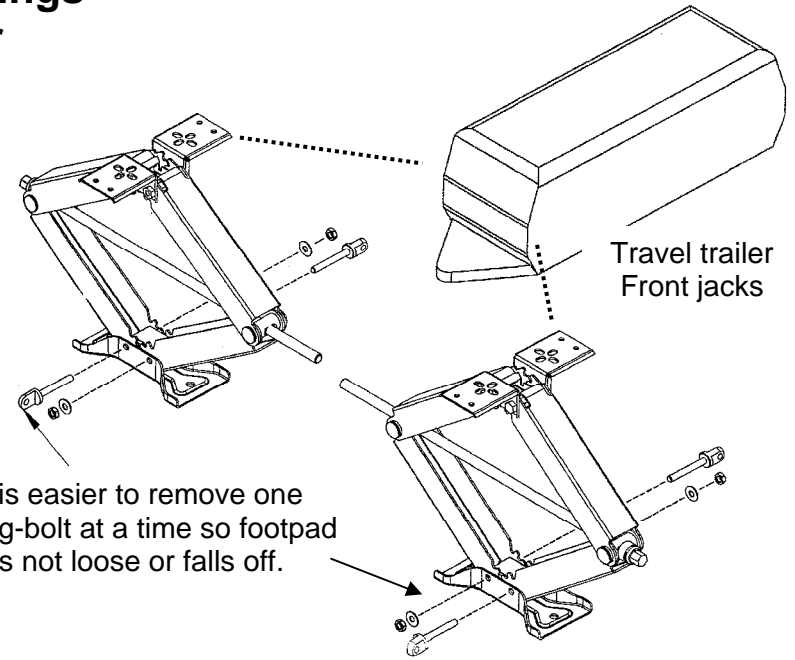

Front View
Left Front Corner

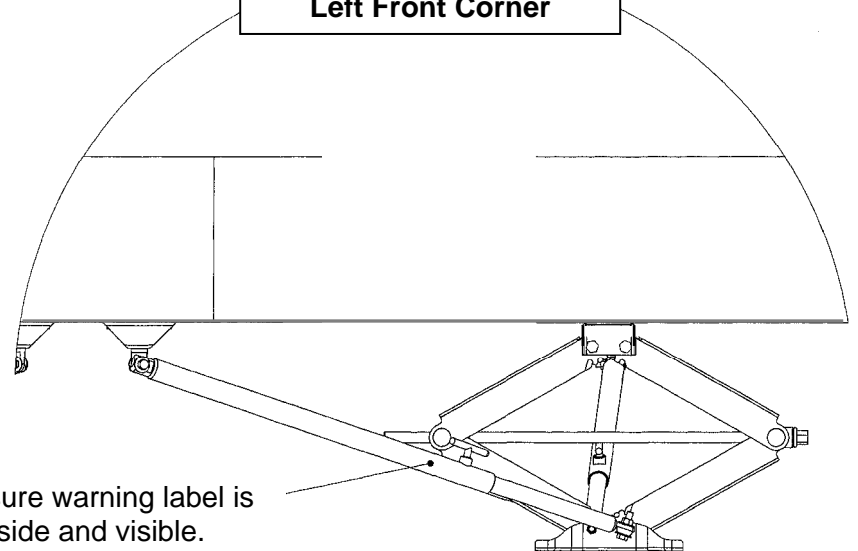

Make sure warning label is outside and visible.

Spacer Mounts and Stiffening Pads

Spacer Mounts

Use a spacer mount when you can't put a Nylock nut on the end of the bolt due to restricted access such as a tube chassis or floor insulation

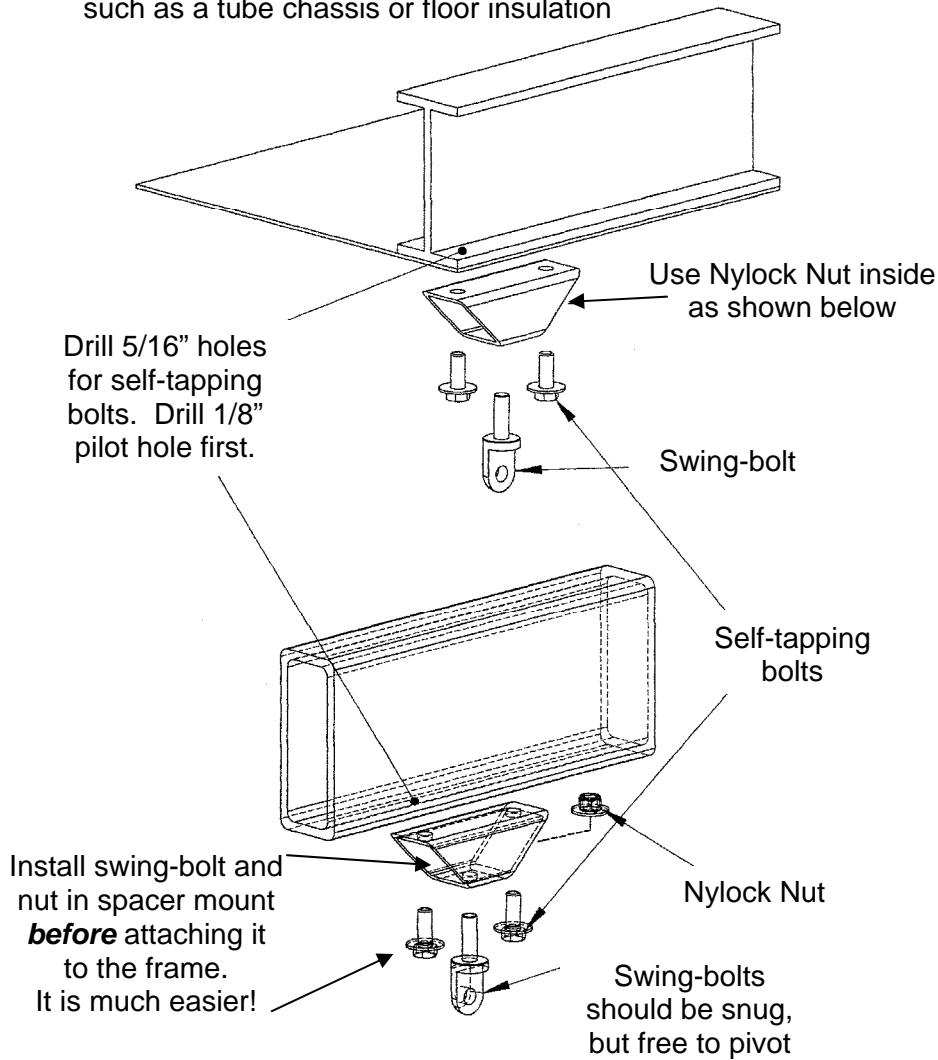

Stiffening Pads

