

FED. TEST METHOD STD. NO. 191A

July 20, 1978

SUPERSEDING

Fed. Test Method. No. 191

December 31, 1968

FEDERAL STANDARD
FOR
TEXTILE TEST METHODS

This standard was approved by the
Commissioner, Federal Supply Service,
General Services Administration, for
the use of all Federal agencies.

U.S. GOVERNMENT PRINTING OFFICE : 1978 - 261-423/1108

Orders for this publication are to be placed with General Services Administration, acting as an agent for the Superintendent of Documents. Single copies of this standard are available, without charge at the GSA Business Service Centers in Boston, New York, Philadelphia, Atlanta, Chicago, Kansas City, MO, Fort Worth, Houston, Denver, San Francisco, Los Angeles, and Seattle, WA. Additional copies may be purchased for 11.25 from the General Services Administration, Specifications Activity, printed Materials Supply Division, Building 197, Naval Weapons Plant, Washington, DC 20407.

FSC 83GP

INFORMATION SHEET

ON

FEDERAL TEST METHOD STANDARDS

This Federal Test Method Standard is issued in looseleaf form to permit the insertion or removal of new or revised sections and test methods.

All users of Federal Test Method Standards should keep them up to date by inserting revised or new test methods as issued, and removing superseded and cancelled pages.

New and revised material and cancellations will be issued under Change Notices which will be numbered consecutively and will bear the date of issuance. Change Notices should be retained and filed in front of the Alphabetical Index of the Standard until such time as they are superseded by a reissue of the entire Standard.

FEDERAL TEST METHOD STANDARD

TEXTILE TEST METHODS

AUTHORITY . This standard is issued pursuant to the Federal Property and Administrative Service Act of 1949, as ammended, and its application to the purchase of commodities referred to herein is mandatory on all Federal agencies.

SECTION 1 - SCOPE AND CONTENTS

1.1 Scope. This standard describes the general physical, chemical and biological methods for testing textile fibers, yarn, thread, rope, other cordage, cloth and fabricated textile products for conformance with the requirements of Federal and Military Specifications. It does not include certain methods which are described in the specifications for the materials to which they apply. This standard was prepared in order to eliminate unnecessary or undesirable variations in the general procedures. In the event that conflict should occur between the requirements of this standard and those contained in a specification or other type of procurement document on date of invitation for bid, the procurement document or specification shall govern.

1.2 Contents. The contents of this standard are as follows:

- Section 1. Scope and Contents
- Section 2. Definitions
- Section 3. Sampling and Number of Specimens
- Section 4. Atmospheric Conditions for Testing
- Section 5. General Notes
- Section 6. Numerical Index of Test Methods
- Section 7. Alphabetical Index of Test Methods
- Section 8. Conversion Equivalentents
- Section 9. Test Methods
- Section 10. Supersession Data, Source Information, and Interested Agencies.

FED. TEST METHOD STD. NO. 191A
July 20, 1978

SECTION 2 - DEFINITIONS

2.1 Scope. For the purpose of this Standard and all procurement documents referring hereto, the following definitions shall apply:

2.2 General Definitions.

2.2.1 Acceptance of a lot. The approval of a lot conforming to contract or specification requirements.

2.2.2 Rejection of a lot. The disapproval of a lot as not conforming to the contract or specification requirements.

2.2.3 Standard sample. A standard sample is a sample of material selected or designated by the Government to meet material requirements and furnished by the Government for testing purposes. The standard sample is used in evaluating the quality of the test specimen for specific characteristics or properties by direct comparison of the test specimen and standard sample under identical conditions. Its purpose is to render a definite description of one or more properties being evaluated.

2.2.4 Test method. A test method is a detailed description of the required way for conducting a test; it is the act of evaluating or determining a required property or characteristic of a single sample unit by taking one or more measurement according to prescribed procedure.

2.2.5 Test result. A test result is the recorded measurement of a required property or characteristic for a single sample unit when such measurement is carried out in conformance with prescribed procedure.

2.3 Definitions applicable to sampling.

2.3.1 Random sampling. Random sampling is the procedure used to select items from the inspection lot so that each item in the lot has an equal chance of being included in the sample. There are many ways of drawing a random sample, perhaps the best one is the use of a table of random numbers. Such a table facilitates the selection of a valid random sample representative of the lot.

2.3.2 Sample. A sample consists of one or more units of a product drawn from a lot, the units being selected at random without regard for quality.

2.3.3 Sample size. The sample size is the number of units of a product in the sample selected for inspection.

2.3.4 Sample for test. A specified number of sample units (units of a product) taken from a lot for the purpose of testing for all physical and chemical properties for which requirements are specified.

2.3.5 Sample unit (for test purposes). The sample unit is the total quantity of material necessary to obtain one test result for each of the properties and characteristics specified in the procurement document. In testing of small package units, the sample unit may be a package unit randomly selected from the material representing the lot. In testing commodities in which the units are individually too small to provide sufficient material for evaluating all the properties specified in the procurement document, the sample unit may be a sufficient number of units of the material, taken as an aggregate, to provide the quantity of material required.

FED. TEST METHOD STD. NO. 191A
July 20, 1978

SECTION 3 - SAMPLING AND NUMBER OF SPECIMENS

3.1 Sampling. The material to be tested shall be sampled as required in the applicable procurement document.

3.2 Number of specimens. The number of specimens to be tested for each property and each sample unit shall be as required by the test method unless specifically excepted in the procurement document.

SECTION 4 - ATMOSPHERIC CONDITIONS FOR TESTING

4.1 Humidity and temperature conditions for testing. Unless otherwise specified in the applicable test method or procurement document, physical tests of textiles and textile products shall be performed under standard atmospheric conditions and performed on specimens in moisture equilibrium under standard atmospheric conditions.

4.1.1 Standard atmospheric conditions. Standard atmospheric conditions for textiles and textile products testing are 65 percent \pm 2 percent relative humidity at a temperature of 70°F \pm 2°F (21°C \pm 1°C).

4.1.2 Moisture equilibrium. Moisture equilibrium is considered to have been reached when, after free exposure of the material to air in motion, controlled at standard atmospheric conditions as defined above, and change in weight in successive weighings made at intervals of one hour is no greater than 0.25 percent.

4.2 Preconditioning. In the event of dispute concerning the results of tests that may be affected by the moisture content, the material shall be preconditioned by being brought to moisture equilibrium with an atmosphere having a relative humidity of not over 10 percent and a temperature not over .25°F (52°C). The material shall then be brought to moisture equilibrium under standard atmospheric conditions as defined above and then tested.

FED. TEST METHOD STD. NO. 191A
July 20, 1978

SECTION 5 - GENERAL NOTES

5.1 Content of Methods.

5.1.1 Principal subdivisions. The methods are organized under the following headings: 1. Scope, 2. Test Specimen, 3. Number of Determinations, 4. Apparatus, Reagents and Method Cited, 5. Procedure, 6. Report and 7. Notes.

5.1.1.1 Scope. A statement of what the test method is intended to do, the property to be measured or evaluated, the material to which the method is applicable, and the limitations of the method.

5.1.1.2 Test specimen. This specifies that portion of a sample unit, its dimensions, and the way in which it is to be taken for a single measurement of a given property or characteristic, and any special preparation the specimen may require.

5.1.1.3 Number of determinations. A statement of the number of test specimens required from each sample unit to be tested.

5.1.1.4 Apparatus, reagents and method(s) cited. A description of the apparatus and reagents required to carry out the test and any other test method(s) forming an integral part of the overall procedure.

5.1.1.5 Procedure. Description of the step-by-step directions for carrying out the test.

5.1.1.5.1 Calculation of results. Description of the techniques required to insure that the required end result of the characteristic being tested is reached.

5.1.1.6 Report. Specific instructions for expressing the results to insure uniformity of expression and recording of the results.

5.1.1.7 Notes. Additional, but not mandatory information (eg. addresses of companies supplying specific apparatus and equipment) which may be used in the performance of a specific test method.

5.2 Significance of Dimensional Statements in Methods.

5.2.1 Forms used. Numerical requirements are given in any of three forms illustrated by the following examples: "approximately 2 grams", "2 grams" and "2.000 ± 0.002 grams".

5.2.1.1 Approximately 2 grams. This form of expression implies that the numerical requirement is not critical and may vary within reason. The permissible variation is usually dictated by obvious practical considerations and the nearest readily obtained approximation to the weight and dimensions may be considered satisfactory.

5.2.1.2 "2 grams". This form of expression implies that the numerical requirement is to be as close to "2 grams" as can be readily measured on the stated material with the usual, ordinary engineering tools.

5.2.1.3 "2.000 ± 0.002 grams". This form of expression implies that the numerical requirement in question must be between 1.998 and 2.002 grams.

5.3 Supplemental Documents.

5.3.1 The Department of Defense has issued two documents supplementing the provisions of this Standard which are intended to further the achievement of standardization of testing techniques and improve obtainment of comparability of test results between Laboratories. These documents are Military Handbook 737, Handbook for Textile Laboratory Personnel, and Military Standard 1157, Calibration and Calibration Verification Procedures for Textile Test Methods. Copies of the Handbook and Standard may be obtained by addressing the procurement activity issuing the invitation for bids.

5.4 Activities outside the Federal Government may obtain copies of Federal Specifications, Standards, and Handbooks as outlined under General Information in the Index of Federal Specifications and Standards and at the prices indicated in the Index. The Index, which includes cumulative monthly supplements as issued, is for sale on a subscription basis by the Superintendent of Documents, U.S. Government Printing Office, Washington, DC 20402.

5.5 Single copies of this standard and other product specifications required by activities outside the Federal Government for bidding purposes are available without charge from Business Service Centers, at the General Services Administration Regional Offices in Boston, New York, Washington, DC, Atlanta, Chicago, Kansas City, MO, Fort Worth, Denver, San Francisco, Los Angeles and Seattle, WA.

5.6 Federal Government activities may obtain copies of Federal Specifications, Standards and Handbooks and the Index of Federal Specifications and Standards from established distribution points in their agencies.

FED. TEST METHOD STD. NO. 191A
 July 20, 1978

SECTION 6 - NUMERICAL INDEX OF TEST METHODS

<u>METHOD NO.</u>	<u>TITLE</u>
<u>Identification - Qualitative Analysis</u>	
1100	Identification of Wool, Mohair, Alpaca and Silk
1200	Identification of Cotton, Flax, Hemp, Ramie and Jute
1240	Identification of Manila (Abaca'), Sisal and Coir
1400	Identification of Asbestos
1410	Identification of Glass
1500	Identification of Rayon, Viscose
1510	Identification of Rayon, Acetate
1520	Identification of Rayon, Cuprammonium
1530	Identification of Nylon
1534	Melting Point of Synthetic Fibers
1540	Identification of Vinylidene Chloride Fibers
1550	Identification of Vinyl Chloride-Acetate Copolymer Fibers
1600	Identification of Synthetic Fibers by Generic Class
1700	Identification of Dyes on Animal Fibers
<u>Quantitative Analysis</u>	
2011	Dihydroxydichlorodiphenyl Methane Content, Calorimetric Method
2012	Dihydroxydichlorodiphenyl Methane Content, Parr Chloride Method
2013	Fluorine Content of Textile Materials
2015	Sodium Salt of 5-Chloro -2- [4 Chloro -2- [3- (3,4 Dichloro-phenyl) -Ureido] -Phenoxy] Benzenesulfonate Content
2016	Sodium Salt of [(4, 5-Dichloro, 2-Chloromethane Sulfonamide) 3', 4', 6', Trichloro] Diphenyl Ether Content
2020	Presence of Labile Sulfur in Textile Materials
2050	Copper Content of Textiles, Electrolytic Method
2051	Copper Content of Textiles, Polarographic Method
2053	Small Amounts of Copper and Manganese in Textiles
2060	Copper-8-Quinolinolate Content of Textiles, Spectrophotometric Method
2100	Wool Content, Acid Method
2101	Wool Content, Alkali Method
2102	Wool Content, Hypochlorite Method
2110	Silk Content of Fiber Mixtures
2111	Silk Fiber Content of Silk Textiles (Especially Weighted Silk)
2510	Cellulose Acetate Content of Fiber Mixtures, Acetic Acid Method
2511	Cellulose Acetate Content of Fiber Mixtures, Acetone Method
2530	Nylon Content of Fiber Mixtures
2535	Polyester Content of Fiber Mixtures

Numerical Index (cont'd)

2600	Moisture Content, Oven Method
2601	Moisture Content, Oven-Balance Method
2610	Nonfibrous Materials in Cotton, Acid Method
2611	Nonfibrous Materials in Cotton, Enzyme Method
2620	Nonfibrous Materials in Linen Textiles
2800	Wool Fiber Damage, Alkali Volubility Method
2810	Acidity (pH) of Textiles, Calorimetric Method
2811	pH of Textiles, Electrometric Method
2820	Chitin Content of Textiles, as a Measure of Fungal Contamination
	<u>Fibers</u>
3810	Becker Value of Cordage Fiber
	<u>Yarn, Thread, Cordage</u>
4010	Length-Weight Relation; Thread; Yards Per Pound (m/kg)
4021	Yarn Number (Linear Density) of Yarn from Package
4050	Direction of Twist: Yarn, Thread, Cordage
4052	Twist in Single Yarns
4054	Twist and Twist Contraction; Ply Yarns
4100	Strength and Elongation, Breaking; and Tenacity; of Thread and Yarn; Single Strand
4104	Strength, Breaking of Thread and Yam; Skein Method
4108	Strength and Elongation, Breaking; Textile Webbing, Tape and Braided Items
4110	Crimp in Yarns from Cloth; Dead-Load Method
4112	Crimp in Yams from Cloth; Load-Elongation Method
4308	Abrasion Resistance of Yarn, Thread, and Light Cordage; Uniform-Abrasion (Schiefer) Method
4500	Water Absorption, Dynamic; Tumble Jar Method
4502	Water Absorption: Thread, Cord, Braid, Tape, Webbing; Immersion Method
4504	Water Resistance, Vertical Rise Wicking, Thread
4800	Weathering Resistance; Yarn, Cordage; Natural Weathering Method
4804	Weathering Resistance; Yam, Thread, Cordage; Accelerated Weathering Method
4830	Leaching Resistance; Cordage; Standard Method
4832	Leaching Resistance; Cordage; Prewet Specimen Method
	<u>Fabrics</u>
5010	Length of Textile Materials; Determination of
5020	Width of Textile Materials; Determination of
5030	Thickness of Textile Materials; Determination of
5040	Weight of Cloth; Cut, Roll, or Bolt Method; Determination of
5041	Weight of Textile Materials, Small Specimen Method; Determination of
5050	Yams Per Unit Length (Inch or Centimeter) in Woven Cloth
5052	Stitches per Unit Length in Seams and Stitchings; Determination of
5060	Bow of Yarns in Woven Cloth

Numerical Index (cont'd)

5070	Wales and Courses in Knit Cloth
5100	Strength and Elongation, Breaking of Woven Cloth; Grab Method
5102	Strength and Elongation, Breaking of Woven Cloth; Cut Strip Method
5104	Strength and Elongation, Breaking of Woven Cloth; Ravel Strip Method
5106	Tension of Elastic Textile Materials
5110	Sewability of Woven Cloth; Seam Efficiency Method
5120	Strength of Cloth; Ball Bursting Method
5122	Strength of Cloth; Diaphragm Bursting Method
5132	Strength of Cloth, Tearing; Falling-Pendulum Method
5134	Strength of Cloth, Tearing; Tongue Method
5200	Stiffness of Cloth, Directional; Hanging Heart Loop Method
5202	Stiffness of Cloth, Directional; Cantilever Bending Method
5204	Stiffness of Cloth, Directional: Self-Weighted Cantilever Method
5206	Stiffness of Cloth, Drape and Flex; Cantilever Bending Method
5210	Crease Resistance of Cloth; Cold Press Recovery Method
5212	Crease Resistance of Cloth; Angle of Recovery Method
5214	Wrinkle Recovery of Fabrics; Appearance Method
5216	Durable Press on Fabrics, Shirts and Trousers: Evaluation of: Cloth Appearance, Seam Appearance, Fly Appearance, Crease Appearance and Soil Release
5220	Flexibility of Cloth After Leaching
5230	Flexing Resistance of Coated Cloth
5300	Abrasion Resistance of Cloth; Flexing, Folding Bar (Stoll) Method
5302	Abrasion Resistance of Cloth; Inflated Diaphragm (Stoll) Method
5303	Color Change of Cloth Due to Flat Abrasion (Frosting); Wire Screen Method
5304	Abrasion Resistance of Cloth; Oscillatory Cylinder (Wyzenbeek) Method
5306	Abrasion Resistance of Cloth; Rotary Platform, Double-Head (Taber) Method
5308	Abrasion Resistance of Cloth; Uniform Abrasion (Schiefer) Method
5309	Abrasion Resistance of Textile Webbing
5310	Appearance-Retention of Cloth; pilling and Surface Wear
5320	Pilling Resistance of Textile Fabrics; Brush and Sponge Method
5400	Sewability of Woven Cloth; Yarn Severance Method
5404	Sewability of Cloths Containing Thermoplastic Synthetic Fibers or Yarns
5410	Slippage Resistance of Yarns in Cloth; Yarn Distortion Method
5420	Slippage Resistance of Yarns in Cloth; Seam Method
5450	Permeability to Air; Cloth; Calibrated Orifice Method
5452	Permeability to Air; Cloth; Falling Cylinder Method

Numerical Index (cont'd)

5500	Water Resistance of Cloth; Dynamic Absorption Method
5502	Water Resistance of Cloth; Immersion Absorption Method
5504	Water Resistance of Coated Cloth; Spray Absorption Method
5506	Dry Cleaning Test, Accelerated; for Labels
5508	Dry Cleaning Solvent Resistance of Cloth With Water-Resistant Finish; Tumble Jar Method
5509	Dry Cleaning Solvent Resistance of Cloth With Water-Resistant Finish; Launder-Ometer Method
5510	Dry Cleaning Resistance of Cloth With Water-Resistant Finish; Rotating Wheel Method
5512	Water Resistance of Coated Cloth: High Range, Hydrostatic Pressure Method
5514	Water Resistance of Cloth; Low Range, Hydrostatic Pressure Method
5516	Water Resistance of Cloth; Water Permeability, Hydrostatic Pressure Method
5518	Laundering Resistance of Cloth With Water-Resistant Finish; Wash Wheel (Wet Mechanical Action) Method
5519	Laundering Test, Accelerated; for Labels
5520	Water Resistance of Cloth; Drop Penetration Method
5522	Water Resistance of Cloth; Water Impact Penetration Method
5524	Water Resistance of Cloth; Rain Penetration Method
5526	Water Resistance of Cloth With Hydrophobic Finish; Spray Method
5528	Water Resistance of Coated Cloth; Spray Method
5530	Penetration Resistance of Cloth To Passage of Feathers and Down; Tumbling Method
5550	Shrinkage in Laundering; Cotton, Linen, and Blended Cotton and Linen Cloth
5552	Shrinkage in Laundering; Cloth Other Than Cotton and Linen
5554	Shrinkage in Laundering; Wool Cloth; Accelerated Method
5556	Mobile Laundry Evaluation For Textile Materials
5558	Shrinkage, Relaxation; Wool Cloth
5580	Shrinkage in Dry Cleaning; Cloth
5590	Shrinkage in Sponging; Wool Cloth
5600	Colorfastness of Textile Materials to Chlorine Bleaching
5605	Colorfastness to Combined Laundering and Bleaching of Textile Materials; Launder-Ometer Method
5610	Colorfastness to Laundering of Cotton and Linen Textile Materials; Launder-Ometer Method
5612	Colorfastness to Laundering of Cotton and Linen Cloth; Wash Wheel Method
5614	Colorfastness to Laundering of Wool, Silk, Rayon and Other Textile Materials; Launder-Ometer Method
5616	Colorfastness to Laundering of Wool, Silk and Rayon Cloth; Wash Wheel Method

Numerical Index (cont'd)

5620	Colorfastness to Dry Cleaning of Textile Materials; Petroleum Solvent
5621	Colorfastness to Wet Cleaning of Textile Materials; Perchloroethylene Solvent (Associated with Dry Cleaning)
5622	Colorfastness to Wet Dry Cleaning of Textile Materials: Petroleum Solvent
5630	Colorfastness of Textile Materials to Water
5632	Colorfastness of Textile Materials to Salt Water and Soap
5640	Colorfastness of Textile Materials to Dry and Wet Heat (Hot Pressing)
5642	Colorfastness of Textile Materials to Dry Heat (Sublimation)
5651	Crocking of Woven and Knitted Cloth; Standard Sample; Munsell Scale Method
5660	Colorfastness to Light of Textile Materials; Accelerated Method
5662	Colorfastness to Light of Textile Materials; Natural Light Method
5671	Colorfastness of Textile Materials to Weather: Accelerated Weathering Method
5672	Colorfastness to Weather of Textile Materials; Natural Weathering Method
5675	Colorfastness of Cloth to Oxides of Nitrogen in the Atmosphere
5680	Colorfastness of Textile Materials to Perspiration; Perspirometer Method
5750	Mildew Resistance of Textile Materials; Single Culture Method
5760	Mildew Resistance of Textile Materials; Mixed Culture Method
5762	Mildew Resistance of Textile Materials; Soil Burial Method
5764	Insect Resistance of Textile Materials
5800	Weathering Resistance of Cloth; Natural Weathering Method
5804	Weathering Resistance of Cloth; Accelerated Weathering Method
5830	Leaching Resistance of Cloth; Standard Method
5831	Leaching Resistance of Cloth; Minimum Exposure Method
5832	Leaching Resistance of Cloth; Prewet Specimen Method
5850	Accelerated Ageing of Cloth; Oven Method
5851	Accelerated Ageing of Cloth; Closed Container Method
5852	Accelerated Ageing of Cloth; Oxygen Method
5870	Temperature, High; Effect on Cloth Flexibility
5872	Temperature, High; Effect on Cloth Blocking
5874	Temperature, Low: Effect on Coated Cloth
5900	Flame Resistance of Cloth; Horizontal
5903	Flame Resistance of Cloth; Vertical
5904	Flame Resistance of Cloth; Vertical, Field
5905	Flame Resistance of Material; High Heat Flux Flame Contact
5906	Flammability, Burning Rate of Cloth; Horizontal
5907	Flammability Test for Sleeping Bag Cloths: Tablet Method
5908	Flammability, Burning Rate of Cloth 45° Angle

Numerical Index (cont'd)

5920	Heating (Spontaneous) of Cloth
5930	Electrical Resistivity of Fabrics; Determination of
5950	Adhesion of Plied (Double Texture) Fabric
5951	Bond Strength of Bonded and Laminated Apparel Cloths
5960	Adhesion of Cemented Seams
5962	Adhesion of Strapped Seams
5964	Adhesion of Wet Seams
5970	Adhesion of Coating; Adhesive Method
5972	Adhesion of Coating; Water Resistance Method
	<u>Cordage (Rope)</u>
6000	Length of Ten Turns; Cordage
6001	Picks Per Inch (Picks/cm); Braided Cordage
6002	Diameter of Cordage
6003	Circumference of Cordage
6004	Length Per Unit Weight; Cordage
6010	Shrinkage of Cordage, Boiling Water Method; Determination of
6011	Water Absorption; Cordage
6015	Strength and Elongation, Breaking of Cordage; Spliced Specimen Method
6016	Strength and Elongation, Breaking of Cordage; Non-Spliced Specimen Method
6020	Hardness; Cordage
	<u>Garments and Ready-Made Articles</u>
7102	Gripping Strength of Shoe Lace Tips
7308	Abrasion Resistance; Socks, Hosiery, and Knitted Cloth; Uniform- Abrasion (Schiefer) Method
7540	Stretched Width of Knit Items
7550	Shrinkage in Laundering of Cotton and Linen Garments and Ready-Made Articles
7552	Shrinkage in Laundering of Garments and Ready-Made Articles Other Than Cotton and Linen
7554	Shrinkage in Laundering of Wool Garments and Ready-Made Articles; Accelerated Method
7556	Shrinkage in Laundering of Garments and Ready-Made Articles; Mobile Laundry Method
7558	Shrinkage Relaxation; Wool Garments and Ready-Made Articles
7560	Shrinkage in Laundering of Shrink-Resistant Wool Socks
7561	Shrinkage in Laundering of Shrink-Resistant Treated Wool Socks; Accelerated Method
7580	Shrinkage in Dry Cleaning; Garments and Ready-Made Articles
7590	Shrinkage in Sponging; Garments and Ready-Made Articles
9010	Shade Matching of Textile Materials; Visual Method

SECTION 7 - ALPHABETICAL INDEX OF TEST METHODS

<u>METHOD NO.</u>	<u>TITLE</u>
5300	Abrasion Resistance of Cloth; Flexing, Folding Bar (Stoll) Method
5302	Abrasion Resistance of Cloth; Inflated Diaphragm (Stoll) Method
5304	Abrasion Resistance of Cloth; Oscillatory Cylinder (Wyzenbeek) Method
5306	Abrasion Resistance of Cloth; Rotary Platform, Double-Head (Taber) Method
5308	Abrasion Resistance of Cloth; Uniform Abrasion (Schiefer) Method
5309	Abrasion Resistance of Textile Webbing
4308	Abrasion Resistance of Yarn, Thread, and Light Cordage; Uniform-Abrasion (Schiefer) Method
7308	Abrasion Resistance; Socks, Hosiery, and Knitted Cloth; Uniform-Abrasion (Schiefer) Method
5851	Accelerated Ageing of Cloth; Closed Container Method
5850	Accelerated Ageing of Cloth; Oven Method
5852	Accelerated Ageing of Cloth; Oxygen Method
2810	Acidity (pH) of Textiles, Calorimetric Method
5960	Adhesion of Cemented Seams
5970	Adhesion of Coating; Adhesive Method
5972	Adhesion of Coating; Water Resistance Method
5950	Adhesion of Plied (Double Texture) Fabric
5962	Adhesion of Strapped Seams
5964	Adhesion of Wet Seams
5310	Appearance-Retention of Cloth; Pilling and Surface Wear
3810	Becker Value of Cordage Fiber
5951	Bond Strength of Bonded and Laminated Apparel Cloths
5060	Bow of Yams in Woven Cloth
2510	Cellulose Acetate Content of Fiber Mixtures, Acetic Acid Method
2511	Cellulose Acetate Content of Fiber Mixtures, Acetone Method
2820	Chitin Content of Textiles, as a Measure of Fungal Contamination
6003	Circumference of Cordage
5303	Color Change of Cloth Due to Flat Abrasion (Frosting); Wire Screen Method
5675	Colorfastness of Cloth to Oxides of Nitrogen in the Atmosphere
5600	Colorfastness of Textile Materials to Chlorine Bleaching
5640	Colorfastness of Textile Materials to Dry and Wet Heat (Hot Pressing)
5642	Colorfastness of Textile Materials to Dry Heat (Sublimation)
5680	Colorfastness of Textile Materials to Perspiration; Perspirometer Method
5632	Colorfastness of Textile Materials to Salt Water and Soap

Alphabetical Index (cont'd)

5630	Colorfastness of Textile Materials to Water
5671	Colorfastness of Textile Materials to Weather; Accelerated Weathering Method
5605	Colorfastness to Combined Laundering and Bleaching of Textile Materials; Launder-Ometer Method
5620	Colorfastness to Dry Cleaning of Textile Materials; Petroleum Solvent
5612	Colorfastness to Laundering of Cotton and Linen Cloth; Wash Wheel Method
5610	Colorfastness to Laundering of Cotton and Linen Textile Materials; Launder-Ometer Method
5614	Colorfastness to Laundering of Wool, Silk, Rayon and Other Textile Materials; Launder-Ometer Method
5616	Colorfastness to Laundering of Wool, Silk and Rayon Cloth; Wash Wheel Method
5660	Colorfastness to Light of Textile Materials; Accelerated Method
5662	Colorfastness to Light of Textile Materials; Natural Light Method
5672	Colorfastness to Weather of Textile Materials; Natural Weathering Method
5621	Colorfastness to Wet Cleaning of Textile Materials; Perchloroethylene Solvent (Associated with Dry Cleaning)
5622	Colorfastness to Wet Dry Cleaning of Textile Materials; Petroleum Solvent
2050	Copper Content of Textiles, Electrolytic Method
2051	Copper Content of Textiles, Polarographic Method
2060	Copper-8-Quinolinolate Content of Textiles, Spectrophotometric Method
5212	Crease Resistance of Cloth; Angle of Recovery Method
5210	Crease Resistance of Cloth; Cold Press Recovery Method
4110	Crimp in Yarns From Cloth; Dead-Load Method
4112	Crimp in Yarns From Cloth; Load-Elongation Method
5651	Crocking of Woven and Knitted Cloth; Standard Sample; Munsell Scale Method
6002	Diameter of Cordage
2011	Dihydroxydichlorodiphenyl Methane Content Calorimetric Method
2012	Dihydroxydichlorodiphenyl Methane Content, Parr Chloride Method
4050	Direction of Twist: Yarn, Thread, Cordage
5510	Dry Cleaning Resistance of Cloth With Water-Resistant Finish; Rotating Wheel Method
5509	Dry Cleaning Solvent Resistance of Cloth With Water-Resistant Finish; Launder-Ometer Method

Alphabetical Index (cont'd)

5508	Dry Cleaning Solvent Resistance of Cloth With Water-Resistant Finish; Tumble Jar Method
5506	Dry Cleaning Test, Accelerated; for Labels
5216	Durable Press on Fabrics, Shirts and Trousers; Evaluation of: Cloth Appearance, Seam Appearance, Fly Appearance, Crease Appearance and Soil Release
5930	Electrical Resistivity of Fabrics; Determination of
5908	Flammability, Burning Rate of Cloth; 45° Angle
5906	Flammability, Burning Rate of Cloth; Horizontal
5907	Flammability Test for Sleeping Bag Cloths; Tablet Method
5900	Flame Resistance of Cloth; Horizontal
5903	Flame Resistance of Cloth; Vertical
5904	Flare Resistance of Cloth; Vertical, Field
5905	Flame Resistance of Material; High Heat Flux Flame Contact
5220	Flexibility of Cloth After Leaching
5230	Flexing Resistance of Coated Cloth
2013	Fluorine Content of Textile Materials
7102	Gripping Strength of Shoe Lace Tips
6020	Hardness; Cordage
5920	Heating (Spontaneous) of Cloth
1400	Identification of Asbestos
1200	Identification of Cotton, Flax, Hemp, Ramie and Jute
1700	Identification of Dyes on Animal Fibers
1410	Identification of Glass
1240	Identification of Manila (Abaca'), Sisal and Coir
1530	Identification of Nylon
1510	Identification of Rayon, Acetate
1520	Identification of Rayon, Cuprammonium
1500	Identification of Rayon, Viscose
1600	Identification of Synthetic Fibers by Generic Class
1550	Identification of Vinyl Chloride-Acetate Copolymer Fibers
1540	Identification of Vinylidene Chloride Fibers
1100	Identification of Wool, Mohair, Alpaca and Silk
5764	Insect Resistance of Textile Materials
5518	Laundrying Resistance of Cloth With Water-Resistant Finish; Wash Wheel (Wet Mechanical Action) Method
5519	Laundrying Test, Accelerated; for Labels
4832	Leaching Resistance; Cordage; Prewet Specimen Method
4830	Leaching Resistance; Cordage; Standard Method
5831	Leaching Resistance of Cloth; Minimum Exposure Method
5832	Leaching Resistance of Cloth; Prewet Specimen Method
5830	Leaching Resistance of Cloth; Standard Method
6000	Length of Ten Turns; Cordage
5010	Length of Textile Materials; Determination of
6004	Length Per Unit Weight; Cordage
4010	Length-Weight Relation; Thread; Yards Per Pound (m/kg)

Alphabetical Index (cont'd)

1534	Melting Point of Synthetic Fibers
5760	Mildew Resistance of Textile Materials; Mixed Culture Method
5750	Mildew Resistance of Textile Materials; Single Culture Method
5762	Mildew Resistance of Textile Materials; Soil Burial Method
5556	Mobile Laundry Evaluation for Textile Materials
2601	Moisture Content, Oven-Balance Method
2600	Moisture Content, Oven Method
2610	Nonfibrous Materials in Cotton, Acid Method
2611	Nonfibrous Materials in Cotton, Enzyme Method
2620	Nonfibrous Materials in Linen Textiles
2530	Nylon Content of Fiber Mixtures
5530	Penetration Resistance of Cloth To Passage of Feathers and Down; Tumbling Method
5450	Permeability to Air; Cloth; Calibrated Orifice Method
5452	Permeability to Air; Cloth; Falling Cylinder Method
2811	pH of Textiles, Electrometric Method
6001	Picks Per Inch (Picks/cm); Braided Cordage
5320	Pilling Resistance of Textile Fabrics; Brush and Sponge Method
2535	Polyester Content of Fiber Mixtures
2020	Presence of Labile Sulfur in Textile Materials
5404	Sewability of Cloths Containing Thermoplastic Synthetic Fibers or Yarns
5110	Sewability of Woven Cloth; Seam Efficiency Method
5400	Sewability of Woven Cloth; Yarn Severance Method
9010	Shade Matching of Textile Materials; Visual Method
5580	Shrinkage in Dry Cleaning; Cloth
7580	Shrinkage in Dry Cleaning; Garments and Ready-Made Articles
5552	Shrinkage in Laundering; Cloth Other Than Cotton and Linen
5550	Shrinkage in Laundering; Cotton, Linen, and Blended Cotton and Linen Cloth
7550	Shrinkage in Laundering of Cotton and Linen Garments and Ready-Made Articles
7556	Shrinkage in Laundering of Garments and Ready-Made Articles; Mobile Laundry Method
7552	Shrinkage in Laundering of Garments and Ready-Made Articles Other Than Cotton and Linen
7561	Shrinkage in Laundering of Shrink-Resistant Treated Wool Socks; Accelerated Method
7560	Shrinkage in Laundering of Shrink-Resistant Wool Socks
7554	Shrinkage in Laundering of Wool Garments and Ready-Made Articles; Accelerated Method
5554	Shrinkage in Laundering; Wool Cloth; Accelerated Method

Alphabetical Index (cont'd)

7590	Shrinkage in Sponging; Garments and Ready-Made Articles
5590	Shrinkage in Sponging; Wool Cloth
6010	Shrinkage of Cordage, Boiling Water Method; Determination of
5558	Shrinkage, Relaxation; Wool Cloth
7558	Shrinkage Relaxation; Wool Garments and Ready-Made Articles
2110	Silk Content of Fiber Mixtures
2111	Silk Fiber Content of Silk Textiles (Especially Weighted Silk)
5420	Slippage Resistance of Yarns in Cloth; Seam Method
5410	Slippage Resistance of Yarns in Cloth; Yam Distortion Method
2053	Small Amounts of Copper and Manganese in Textiles
2015	Sodium Salt of 5-Chloro -2- [4 Chloro -2- [3- (3, 4 Dichloro-phenyl) -Ureido] -Phenoxy] Benzenesulfonate Content
2016	Sodium Salt of [(4, 5-Dichloro, 2-Chloromethane Sulfonamide) 3', 4', 6', Trichloro] Diphenyl Ether Content
5202	Stiffness of Cloth, Directional; Cantilever Binding Method
5200	Stiffness of Cloth, Directional; Hanging Heart Loop Method
5204	Stiffness of Cloth, Directional; Self-weighted Cantilever Method
5206	Stiffness of Cloth, Drape and Flex; Cantilever Bending Method
5052	Stitches per Unit Length in Seams and Stitchings; Determination of
6016	Strength and Elongation, Breaking of Cordage; Non-Spliced Specimen Method
6015	Strength and Elongation, Breaking of Cordage; Spliced Specimen Method
5102	Strength and Elongation, Breaking of Woven Cloth; Cut Strip Method
5100	Strength and Elongation, Breaking of Woven Cloth; Grab Method
5104	Strength and Elongation, Breaking of Woven Cloth; Ravel Strip Method
4108	Strength and Elongation, Breaking; Textile Webbing, Tape and Braided I terns
4100	Strength and Elongation, Breaking; and Tenacity; of Thread and Yarn; Single Strand
4104	Strength, Breaking of Thread and Yarn: Skein Method
5120	Strength of Cloth; Ball Bursting Method
5122	Strength of Cloth; Diaphragm Bursting Method
5132	Strength of Cloth, Tearing; Falling-Pendulum Method
5134	Strength of Cloth, Tearing; Tongue Method
7540	Stretched Width of Knit Items
5872	Temperature, High; Effect on Cloth Blocking
5870	Temperature, High; Effect on Cloth Flexibility
5874	Temperature, Low; Effect on Coated Cloth
5106	Tension of Elastic Textile Materials
5030	Thickness of Textile Materials; Determination of

Alphabetical Index (cont'd)

4054	Twist and Twist Contraction; Ply Yarns
4052	Twist in Single Yarns
5070	Wales and Courses in Knit Cloth
6011	Water Absorption; Cordage
4500	Water Absorption, Dynamic; Tumble Jar Method
4502	Water Absorption: Thread, Cord, Braid, Tape, Webbing; Immersion Method
5520	Water Resistance of Cloth; Drop Penetration Method
5500	Water Resistance of Cloth; Dynamic Absorption Method
5502	Water Resistance of Cloth; Immersion Absorption Method
5514	Water Resistance of Cloth; Low Range, Hydrostatic Pressure Method
5524	Water Resistance of Cloth; Rain Penetration Method
5522	Water Resistance of Cloth; Water Impact Penetration Method
5516	Water Resistance of Cloth; Water Permeability, Hydrostatic Pressure Method
5526	Water Resistance of Cloth with Hydrophobic Finish; Spray Method
5512	Water Resistance of Coated Cloth; High Range, Hydrostatic Pressure Method
5504	Water Resistance of Coated Cloth; Spray Absorption Method
5528	Water Resistance of Coated Cloth; Spray Method
4504	Water Resistance, Vertical Rise Wicking, Thread
5804	Weathering Resistance of Cloth; Accelerated Weathering Method
5800	Weathering Resistance of Cloth; Natural Weathering Method
4800	Weathering Resistance; Yarn, Cordage; Natural Weathering Method
4804	Weathering Resistance; Yarn, Thread, Cordage; Accelerated Weathering Method
5040	Weight of Cloth; Cut, Roll, or Bolt Method; Determination of
5041	Weight of Textile Materials, Small Specimen Method; Determination of
5020	Width of Textile Materials; Determination of
2100	Wool Content, Acid Method
2101	Wool Content, Alkali Method
2102	Wool Content, Hypochlorite Method
2800	Wool Fiber Damage, Alkali Volubility Method
5214	Wrinkle Recovery of Fabrics; Appearance Method
4021	Yarn Number (Linear Density) of Yarn From Package
5050	Yarns Per Unit Length (Inch or Centimeter) in Woven Cloth

FED. TEST METHOD STD. NO. 191A
 July 20, 1978

SECTION 8 - CONVERSION EQUIVALENTS

8.1 Temperature conversion.8.1.1 Celsius to Fahrenheit scales:

$$\frac{9}{5} \text{ } ^\circ\text{C} + 32 = \text{ } ^\circ\text{F}$$

$^{\circ}\text{C}$	$^{\circ}\text{F}$	$^{\circ}\text{C}$	$^{\circ}\text{F}$	$^{\circ}\text{C}$	$^{\circ}\text{F}$	$^{\circ}\text{C}$	$^{\circ}\text{F}$	$^{\circ}\text{C}$	$^{\circ}\text{F}$
-20	-4.0	9	48.2	38	100.4	67	152.6	96	204.8
-19	-2.2	10	50.	39	102.2	68	154.4	97	206.6
-18	-0.4	11	51.8	40	104.	69	156.2	98	208.4
-17	1.4	12	53.6	41	105.8	70	158.	99	210.2
-16	3.2	13	55.4	42	107.6	71	159.8	100	212.
-15	5.	14	57.2	43	109.4	72	161.6	101	213.8
-14	6.8	15	59.	44	111.2	73	163.4	102	215.6
-13	8.6	16	60.8	45	113.	74	165.2	103	217.4
-12	10.4	17	62.6	46	114.8	75	167.	104	219.2
-11	12.2	18	64.4	47	116.6	76	168.8	105	221.
-10	14.	19	66.2	48	118.4	77	170.6	106	222.8
-9	15.8	20	68.	49	120.2	78	172.4	107	224.6
-8	17.6	21	69.8	50	122.	79	174.2	108	226.4
-7	19.4	22	71.6	51	123.8	80	176.	109	228.2
-6	21.2	23	73.4	52	125.6	81	177.8	110	230.
-5	23.	24	75.2	53	127.4	82	179.6	111	231.8
-4	24.8	25	77.	54	129.2	83	181.4	112	233.6
-3	26.6	26	78.8	55	131.	84	183.2	113	235.4
-2	28.4	27	80.6	56	132.8	85	185.	114	237.2
-1	30.2	28	82.4	57	134.6	86	186.8	115	239.
0	32.	29	84.2	58	136.4	87	188.6	116	240.8
1	33.8	30	86.	59	138.2	88	190.4	117	242.6
2	35.6	31	87.8	60	140.	89	192.2	118	244.4
3	37.4	32	89.6	61	141.8	90	194.	119	246.2
4	39.2	33	91.4	62	143.6	91	195.8	120	248.
5	41.	34	93.2	63	145.4	92	197.6	121	249.8
6	42.8	35	95.	64	147.2	93	199.4	122	251.6
7	44.6	36	96.8	65	149.	94	201.2	123	253.4
8	46.4	37	98.6	66	150.8	95	203.	124	255.2

8.1.1 Celsius to Fahrenheit scales: (cont 'd)

$$\frac{9}{5} \text{ } ^\circ\text{C} + 32 = \text{ } ^\circ\text{F}$$

$^\circ\text{C}$	$^\circ\text{F}$	$^\circ\text{C}$	$^\circ\text{F}$	$^\circ\text{C}$	$^\circ\text{F}$	$^\circ\text{C}$	$^\circ\text{F}$	$^\circ\text{C}$	$^\circ\text{F}$
125	257.	136	276.8	147	296.6	158	316.4	169	336.2
126	258.8	137	278.6	148	298.4	159	318.2	170	338.
127	260.6	138	280.4	149	300.2	160	320.	171	339.8
128	262.4	139	282.2	150	302.	161	321.8	172	341.6
129	264.2	140	284.	151	303.8	162	323.6	173	343.4
130	266.	141	285.8	152	305.6	163	325.4	174	345.2
131	267.8	142	287.6	153	307.4	164	327.2	175	347.
132	269.6	143	289.4	154	309.2	165	329.	176	348.8
133	271.4	144	291.2	155	311.	166	330.8	177	350.6
134	273.2	145	293.	156	312.8	167	332.6	178	352.4
135	275.	146	294.8	157	314.6	168	334.4	179	354.2
								180	356.

8.1.2 Fahrenheit to Celsius scales:

$$(\text{ } ^\circ\text{F} - 32) \times \frac{5}{9} = \text{ } ^\circ\text{C}$$

$^\circ\text{F}$	$^\circ\text{C}$	$^\circ\text{F}$	$^\circ\text{C}$	$^\circ\text{F}$	$^\circ\text{C}$	$^\circ\text{F}$	$^\circ\text{C}$	$^\circ\text{F}$	$^\circ\text{C}$
0	-17.78	15	-9.44	30	-1.11	45	7.22	60	15.56
1	-17.22	16	-8.89	31	-0.56	46	7.78	61	16.11
2	-16.67	17	-8.33	32	0.	47	8.33	62	16.67
3	-16.11	18	-7.78	33	0.56	48	8.89	63	17.22
4	-15.56	19	-7.22	34	1.11	49	9.44	64	17.78
5	-15.	20	-6.67	35	1.67	50	10.	65	18.33
6	-14.44	21	-6.11	36	2.22	51	10.56	66	18.89
7	-13.89	22	-5.56	37	2.78	52	11.11	67	19.44
8	-13.33	23	-5.	38	3.33	53	11.67	68	20.
9	-12.78	24	-4.44	39	3.89	54	12.22	69	20.56
10	-12.22	25	-3.89	40	4.44	55	12.78	70	21.11
11	-11.67	26	-3.33	41	5.	56	13.33	71	21.67
12	-11.11	27	-2.78	42	5.56	57	13.89	72	22.22
13	-10.56	28	-2.22	43	6.11	58	14.44	73	22.78
14	-10.	29	-1.67	44	6.67	59	15.	74	23.33

8.1.2 Fahrenheit to Celsius scales: (cont'd)

$$(^{\circ}\text{F} - 32) \times \frac{5}{9} = ^{\circ}\text{C}$$

$^{\circ}\text{F}$	$^{\circ}\text{C}$	$^{\circ}\text{F}$	$^{\circ}\text{C}$	$^{\circ}\text{F}$	$^{\circ}\text{C}$	$^{\circ}\text{F}$	$^{\circ}\text{C}$	$^{\circ}\text{F}$	$^{\circ}\text{C}$
75	23.89	111	43.89	147	63.89	183	83.89	219	103.89
76	24.44	112	44.44	148	64.44	184	84.44	220	104.44
77	25.	113	45.	149	65.	185	85.	221	105.
78	25.56	114	45.56	150	65.56	186	85.56	222	105.56
79	26.11	115	46.11	151	66.11	187	86.11	223	106.11
80	26.67	116	46.67	152	66.67	188	86.67	224	106.67
81	27.22	117	47.22	153	67.22	189	87.22	225	107.22
82	27.78	118	47.78	154	67.78	190	87.78	226	107.78
83	28.33	119	48.33	155	68.33	191	88.33	227	108.33
84	28.89	120	48.89	156	68.89	192	88.89	228	108.89
85	29.44	121	49.44	157	69.44	193	89.44	229	109.44
86	30.	122	50.	158	70.	194	90.	230	110.
87	30.56	123	50.56	159	70.56	195	90.56	231	110.56
88	31.11	124	51.11	160	71.11	196	91.11	232	111.11
89	31.67	125	51.67	161	71.67	197	91.67	233	111.67
90	32.22	126	52.22	162	72.22	198	92.22	234	112.22
91	32.78	127	52.78	163	72.78	199	92.78	235	112.78
92	33.33	128	53.33	164	73.33	200	93.33	236	113.33
93	33.89	129	53.89	165	73.89	201	93.89	237	113.89
94	34.44	130	54.44	166	74.44	202	94.44	238	114.44
95	35.	131	55.	167	75.	203	95.	239	115.
96	35.56	132	55.56	168	75.56	204	95.56	240	115.56
97	36.11	133	56.11	169	76.11	205	96.11	241	116.11
98	36.67	134	56.67	170	76.67	206	96.67	242	116.67
99	37.22	135	57.22	171	77.22	207	97.22	243	117.22
100	37.78	136	57.78	172	77.78	208	97.78	244	117.78
101	38.33	137	58.33	173	78.33	209	98.33	245	118.33
102	38.89	138	58.89	174	78.89	210	98.89	246	118.89
103	39.44	139	59.44	175	79.44	211	99.44	247	119.44
104	40.	140	60.	176	80.	212	100.	248	120.
105	40.56	141	60.56	177	80.56	213	100.56	249	120.56
106	41.11	142	61.11	178	81.11	214	101.11	250	121.11
107	41.67	143	61.67	179	81.67	215	101.67		
108	42.22	144	62.22	180	82.22	216	102.22		
109	42.78	145	62.78	181	82.78	217	102.78		
110	43.33	146	63.33	182	83.33	218	103.33		

8.2 Relative humidity, percent (based on Celsius scale at pressure of 29.94 inches).

Air Temp. (t)	Depression of Wet-bulb thermometer (t-t1)																			
	t = dry-bulb (air) temperature										t1 = wet-bulb temperature									
	0.5	1.0	1.5	2.0	2.5	3.0	3.5	4.0	4.5	5.0	5.5	6.0	6.5	7.0	7.5	8.0	8.5	9.0	9.5	10.0
10	94	88	82	77	71	66	60	55	50	44	39	34	29	24	20	15	10	6	-	-
11	94	89	83	78	72	67	61	56	51	46	41	36	32	27	22	18	13	9	5	-
12	94	89	84	78	73	68	63	58	53	48	43	39	34	29	25	21	16	12	8	-
13	95	89	84	79	74	69	64	59	54	50	45	41	36	32	28	23	19	15	11	7
14	95	90	85	79	75	70	65	60	56	51	47	42	38	34	30	26	22	18	14	10
15	95	90	85	80	75	71	66	61	57	53	48	44	40	36	32	27	24	20	16	13
16	95	90	85	81	76	71	67	63	58	54	50	46	42	38	34	30	26	23	19	15
17	95	90	86	81	76	72	68	64	60	55	51	47	43	40	36	32	28	25	21	18
18	95	91	86	82	77	73	69	65	61	57	53	49	45	41	38	34	30	27	23	20
19	95	91	87	82	78	74	70	65	62	58	54	50	46	43	39	36	32	29	26	22
20	96	91	87	83	78	74	70	66	63	59	55	51	48	44	41	37	34	31	28	24
21	96	91	87	83	79	75	71	67	64	60	56	53	49	46	42	39	36	32	29	26
22	96	92	87	83	80	76	72	68	64	61	57	54	50	47	44	40	37	34	31	28
23	96	92	88	84	80	76	72	69	65	62	58	55	52	48	45	42	39	36	33	30
24	96	92	88	84	80	77	73	69	66	62	59	56	53	49	46	43	40	37	34	31
25	96	92	88	84	81	77	74	70	67	63	60	57	54	50	47	44	41	39	36	33
26	96	92	88	85	81	78	74	71	67	64	61	58	54	51	49	46	43	40	37	34
27	96	92	89	85	82	78	75	71	68	65	62	58	56	52	50	47	44	41	38	36
28	96	93	89	85	82	78	75	72	69	65	62	59	56	53	51	48	45	42	40	37
29	96	93	89	86	82	79	76	72	69	66	63	60	57	54	52	49	46	43	41	38
30	96	93	89	86	83	79	76	73	70	67	64	61	58	55	52	50	47	44	42	39
31	96	93	90	86	83	80	77	73	70	67	64	61	59	56	53	51	48	45	43	40
32	96	93	90	86	83	80	77	74	71	68	65	62	60	57	54	51	49	46	44	41
33	97	93	90	87	83	80	77	74	71	68	66	63	60	57	55	52	50	47	45	42
34	97	93	90	87	84	81	78	75	72	69	66	63	61	58	56	53	51	48	46	43

8.3 Metric equivalents. Metric equivalents, indicated in parentheses throughout the test methods, are based on practices, conversion factors, and symbols specified in ASTM E 380 Standard for Metric Practice, and are for information only.

SECTION 9 - TEST METHODS

FED. TEST METHOD STD. NO. 191A

IDENTIFICATION OF WOOL, MOHAIR, ALPACA AND SILK

1. SCOPE

1.1 This method is intended for distinguishing sheep's wool, mohair, alpaca and silk from vegetable, man-made, and mineral fibers. This method is not intended for quantitative determination of these fibers in a blend of fibers.

2. TEST SPECIMEN

2.1 The specimen shall be representative of the sample unit. If there is any evidence of nonhomogeneity, the specimen shall be composed of each variable portion.

3. NUMBER OF DETERMINATIONS

3.1 Unless otherwise specified in the procurement document, one specimen shall be tested from each sample unit. If fibers or yarns dyed different colors are in the lot, at least two specimens of each color shall be taken for test.

4. APPARATUS AND REAGENTS

4.1 Apparatus.

4.1.1 Reference standard. At least one authentic sample of each of sheep's wool, mohair, alpaca and silk shall be kept as a reference standard.

4.1.2 Microscope and accessories. The apparatus for microscopic examination shall consist of a compound microscope, dissecting needles, glass slides, cover glasses and a cross-sectioning device. The microscope shall be equipped to permit examination of magnifications ranging from 100X to 500X.

4.1.3 Mounting medium. The umounting medium for microscopic examination shall be a colorless immersion oil with a refractive index of 1.480 ± 0.005 at 20°C and a viscosity of 78.81 sec. Saybolt Universal at 38°C (see 7.1).

4.2 Reagents.

4.2.1 Millon's reagent. Millon's reagent shall be prepared by dissolving 1 ml of mercury in 9 ml of concentrated nitric acid (94 percent) and diluted with 10 ml of distilled water. This preparation shall be made under a hood. Since this reagent is unstable, it shall be freshly prepared.

METHOD 1100

5. PROCEDURE

5.1 Preparation of specimen. The specimen shall be washed in or extracted with 1,1,1-trichloroethane, ether or alcohol to remove oils, waxes, dirt or any other material that may obscure the fiber characteristics. If it is necessary to remove the dyes from the specimen which may interfere with the identification, they may be removed by any procedure that does not damage the fiber or change any of its characteristics. The specimen shall then be dried.

5.2 Mounting of specimen.

5.2.1 Longitudinal examination. At least a dozen fibers shall be placed on each of two separate slides. On one slide, the fibers shall be immersed in two or three drops of mounting medium and covered with a cover glass. On the second slide, the fibers shall be immersed in two or three drops of Millon's reagent and gently warmed after covering with a cover glass.

5.2.2 Cross-sectional examination. Using the cross-sectioning device a cross-section of at least a dozen fibers shall be prepared and placed on a slide. The cross-section shall be immersed in two or three drops of umounting medium and covered with a cover glass.

5.3 Microscopic examination. The microscopic examination of the prepared slides shall be made with transmitted light at a magnification of 100X. If this magnification is not sufficient for positive identification, a higher magnification shall be used. The microscopic appearance of the specimen shall be compared with that of reference standard prepared in the same manner as the specimen.

5.4 Identification.

5.4.1 All protein fibers are colored red to red-brown by Millon's reagent.

5.4.2 The microscopic appearance readily distinguishes wool, mohair and alpaca from silk, vegetable, man-made and mineral fibers by the epidermis in the form of surface scales.

5.4.3 Wool fibers. Wool fibers are characterized by pronounced overlapping scales and have individual fiber diameters ranging from 10 to 70 micrometers. The smaller fibers are nearly circular in cross-section, but the larger fibers are often oval or elliptical (Figure 1100A). Wool fibers are seldom pigmented or medullated.

METHOD 1100

5.4.4 Mohair fibers. Mohair fibers are characterized by a faint epidermis and uniformity of fiber diameter. The individual fiber diameters range from 10 to 90 micrometers. Majority of fibers are nearly circular in cross-section (Figure 1100B). Mohair fibers are seldom pigmented or medullated.

5.4.5 Alpaca fibers. Alpaca fibers are characterized by a faint epidermis with serrated edge and by the presence of fragmental, interrupted or continuous medulla in majority of the fibers. The individual fiber diameters range from 10 to 50 micrometers. The smaller fibers are nearly circular in cross-section but the larger fibers tend to be elongated oval shaped (Figure 1100C). Streaky pigmentation is occasionally present in alpaca fibers.

5.4.6 Silk fibers. The microscopic appearance readily distinguishes silk fibers from other animal, vegetable, man-made and mineral fibers. Longitudinally the fibers look like non-uniform glass rods with individual diameters ranging from 10 to 15 micrometers. Cross-sections of fibers vary from triangular with rounded corners to elliptical shape (Figure 1100D). The fibers show diagonal markings but no longitudinal markings.

6. REPORT

6.1 The presence or absence of wool, mohair, alpaca or silk shall be reported.

6.2 If fibers other than the fiber being identified are present, the presence of other fibers shall also be reported.

7. NOTES

7.1 Immersion oil suitable for microscopic examination may be obtained from Wool Associated of New York Cotton Exchange, Inc., 286 Summer Street, Boston, MA 02210.

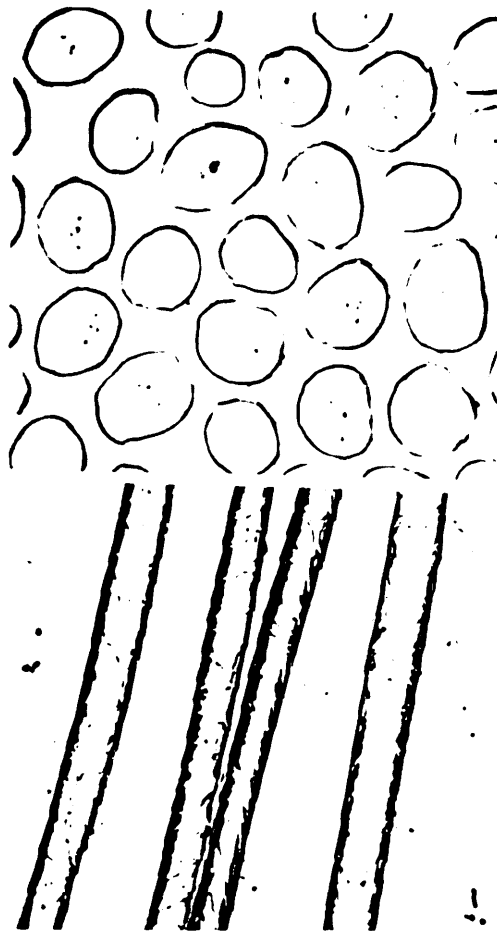

Cross-Sectional
View (500X)

Longitudinal
View (250X)

FIGURE 1100A Wool Fibers

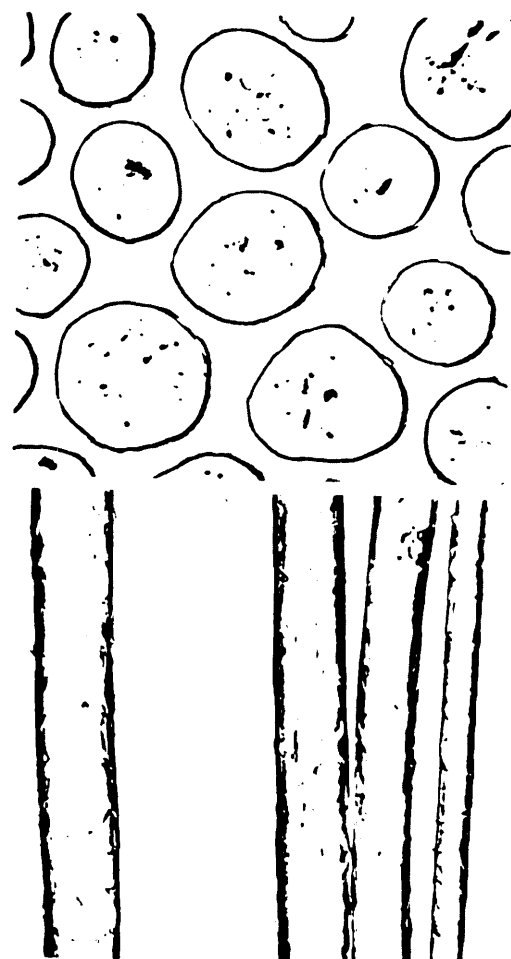

Cross-Sectional
View (500x)

Longitudinal
View (250X)

FIGURE 1100B Mohair Fibers

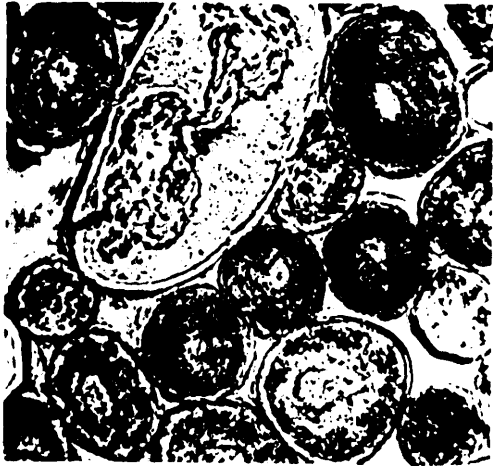

Cross-Sectional
View (500X)



Longitudinal
View (240X)

FIGURE 1100C Alpaca Fibers

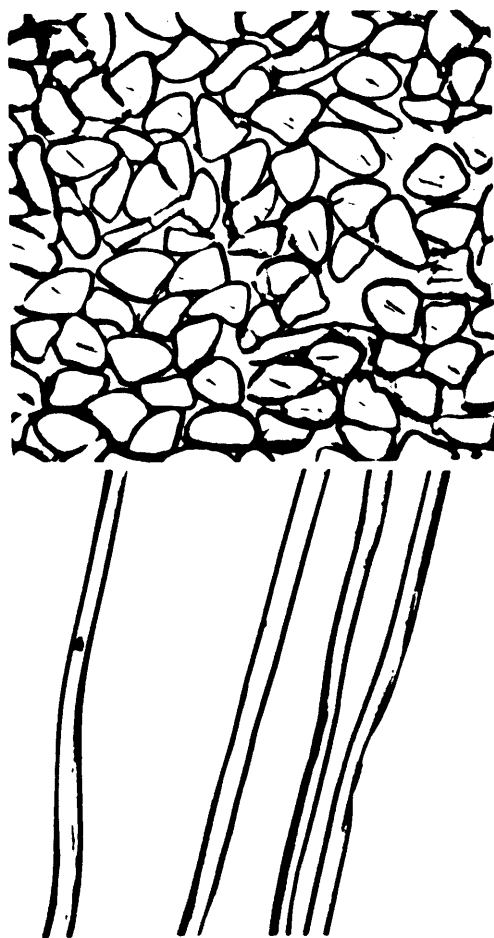

Cross-Sectional
View (500X)

Longitudinal
View (250X)

FIGURE 1100D Silk Fibers

IDENTIFICATION OF COTTON, FLAX, HEMP, RAMIE AND JUTE

1. SCOPE

1.1 This method is intended for distinguishing cotton, flax, hemp, ramie and jute from other vegetable, animal, man-made and mineral fibers. This method is not applicable for determining whether cotton has been subjected to a mercerization process or for distinguishing different species and varieties of cotton. This method is not intended for quantitative determination of these fibers in a blend of fibers.

2. TEST SPECIMEN

2.1 The specimen shall be representative of the sample unit. If there is any evidence of nonhomogeneity, the specimen shall be composed of each variable portion.

3. NUMBER OF DETERMINATIONS

3.1 Unless otherwise specified in the procurement document, one specimen shall be tested from each sample unit. If fibers or yarns dyed different colors are in the lot, at least two specimens of each color shall be taken for test.

4. APPARATUS AND REAGENTS

4.1 Apparatus.

4.1.1 Reference standard. At least one authentic sample of each of the following shall be kept as a reference standard.

- Average American Cotton
- Unbleached and bleached flax
- Unbleached and bleached hemp
- Unbleached and bleached ramie
- Commercial jute

4.1.2 Microscope and accessories. The apparatus for microscopic examination shall consist of a compound microscope, dissecting needles, glass slides, cover glasses, and a cross-sectioning device. The microscope shall be equipped to permit examination of magnifications ranging from 100X to 500X.

METHOD 1200

4.1.3 Blotter.4.2 Reagents.

4.2.1 Herzberg's stain. The Herzberg's stain shall be prepared as follows:

4.2.1.1 Solution A. Zinc chloride solution at 1.80 specific gravity at 28°C made by adding 25 ml of distilled water to 50 g of dry CP Zinc chloride (fused sticks in sealed bottles, or crystals).

4.2.1.2 Solution B. 0.25 g of CP iodine and 5.25 g of CP potassium iodine dissolved in 12.5 ml of distilled water.

4.2.1.3 Stain. Mix 25 ml of solution A, measured at 20°C with solution B. Pour into a narrow cylinder and let stand until clear (12 to 24 hours). Decant the supernatant liquid into an amber-colored glass-stoppered bottle and add a piece of iodine to the solution. Avoid undue exposure to light and air.

4.2.2 Solution of one gram of phloroglucinol in 80 ml of 95 percent alcohol.

4.2.3 Concentrated hydrochloric acid.

5. PROCEDURE

5.1 Preparation of specimen. The specimen shall be washed in or extracted with 1,1,1-trichloroethane, ether or alcohol to remove oils, waxes, dirt or any other material that may obscure the fiber characteristics. It may also be necessary to treat vegetable fibers with 0.5 percent sodium hydroxide solution, as this aids in breaking up fiber bundles. If it is necessary to remove dyes from the specimen which may interfere with the identification, they may be removed by any procedure that does not damage the fiber or change any of its characteristics. The specimen shall then be dried.

5.2 Mounting of specimen. At least a dozen fibers shall be placed on a slide. The fibers shall be immersed in three or four drops of Herzberg's stain, covered with a cover glass in such a manner as to avoid air bubbles, allowed to stand for 1 or 2 minutes, and the surplus stain then drained off by tipping the slide edgewise on a blotter.

5.3 Microscopic examination. The microscopic examination of the prepared slide shall be made with transmitted light at a magnification of 100X. If this magnification is not sufficient for positive identification, a higher magnification shall be used. The microscopic appearance of the specimen shall be compared with the reference standard prepared in the same manner as the specimen.

5.4 In the preliminary examination and preparation of jute, a small bundle of the clean fibers shall be immersed for 30 seconds in a freshly prepared solution made by combining equal parts by volume of the reagents phloroglucinol and concentrated hydrochloric acid.

5.5 Identification.

5.5.1 Cotton fibers. Microscopically, cotton fibers appear like a collapsed rubber tube twisted in an irregular spiral. They have no longitudinal or cross markings. The lumens vary from very narrow to over two-thirds the diameter of the fibers (Figure 1200A). Diameters of individual fibers vary from 9 to 25 micrometers and the average from 16 to 20 micrometers. Undyed cotton fibers are stained pink to dark red in color by Herzberg's stain.

5.5.2 Flax or linen fibers. Flax or linen fibers range in individual diameters from 12 to 25 micrometers. When mounted in Herzberg's stain and viewed through a microscope, the fibers exhibit numerous cross markings known as "nodes" which occur frequently along the length of the fiber (Figure 1200B). Unbleached flax fibers are stained reddish gray to purple in color by Herzberg's stain and bleached flax fibers are stained reddish blue.

5.5.3 Hemp fibers. Hemp fibers range in individual diameters from 15 to 50 micrometers. When mounted in Herzberg's stain and viewed through a microscope, the fibers exhibit numerous cross markings known as "nodes" which occur frequently along the length of the fiber. Fibers also exhibit longitudinal cracks (Figure 1200C). Unbleached hemp fibers are stained a greenish-purple color by Herzberg's stain and bleached hemp fibers are stained reddish-blue.

5.5.4 Ramie fibers. Ramie fibers range in individual diameters from 20 to 80 micrometers. When mounted in Herzberg's stain and viewed through a microscope, the fibers exhibit cross-markings known as "nodes". Ramie fibers are stained a pink to a bluish-red or reddish-purple color by Herzberg's stain. Young fully bleached fibers may stain blue. Fiber cross-sections show characteristic cracks in cell walls and the unusually large periphery which distinguishes ramie from hemp and flax (Figure 1200D).

5.5.5 When a single fiber (flax, hemp, or ramie) is wetted with water and held with the free end toward the observer, flax and ramie fibers rotate in a clockwise direction, while hemp fiber rotates in a counter-clockwise direction.

5.5.6 Jute fibers. Jute fibers range in individual diameters from 20 to 25 micrometers. Jute fibers do not exhibit cross-markings and are stained bright yellow by Herzberg's stain. The fibers are stained a dark violet red when immersed in a phloroglucinol-hydrochloric acid solution. The fiber cross-sections are sharply polygonal in shape (Figure 1200E).

METHOD 1200

6. REPORT

6.1 The presence or absence of cotton, flax, hemp, ramie, or jute shall be reported.

6.2 If fibers other than the fiber being identified are present, the presence of other fibers shall also be reported.



Cross-Sectional
View (500X)

Longitudinal
View (500X)

FIGURE 1200A Cotton Fibers



Cross-Sectional
View (500X)



Longitudinal
View (500X)

FIGURE 1200B Flax Fibers

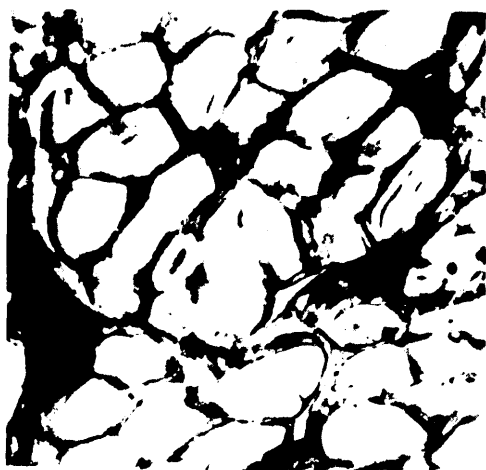

Cross-Sectional
View (500X)



↑
cell end

Longitudinal
View (500X)

FIGURE 1200C Hemp Fibers



Cross-Sectional
View (500X)



Longitudinal
View (115X)

FIGURE 1200D Ramie Fibers



Cross-Sectional
View (550K)



Longitudinal
View (500X)

FIGURE 1200E Jute Fibers

METHOD 1240
July 20, 1978

IDENTIFICATION OF MANILA (ABACA'), SISAL AND COIR

1. SCOPE

1.1 This method is intended for distinguishing manila, sisal and coir from other vegetable, animal, man-made and mineral fibers. This method is not intended for quantitative determination of these fibers in a blend of fibers.

2. TEST SPECIMEN

2.1 The specimen shall be representative of the sample unit. If there is any evidence of nonhomogeneity the specimen shall be composed of each variable portion. The specimen shall not be less than 2 g of the fiber.

3. NUMBER OF DETERMINATIONS

3.1 Unless otherwise specified in the procurement document, one specimen shall be tested from each sample unit. If fibers or yarns dyed different colors are in the lot, at least two specimens of each color shall be taken for test.

4. APPARATUS AND REAGENTS

4.1 Apparatus.

4.1.1 Reference standard. At least one authentic sample of each of manila, sisal, and coir shall be kept as a reference standard.

4.1.2 Microscope and accessories. The apparatus for microscopic examination shall consist of a compound microscope, dissecting needles, glass slides, cover glasses and a cross-sectioning device. The microscope shall be equipped to permit examination of magnifications ranging from 100X to 500X.

4.1.3 Muffle furnace.

4.1.4 Porcelain crucible.

4.2 Reagents.

4.2.1 Nitric acid. Five percent solution of nitric acid prepared by diluting 5 ml of concentrated nitric acid, specific gravity 1.42, to a volume of 70 ml with distilled water.

4.2.2 Sodium hydroxide. Five percent solution of sodium hydroxide.

FED. TEST METHOD STD. NO. 191A

METHOD 1240

5. PROCEDURE

5.1 Preparation of specimen. The specimen shall be washed in or extracted with 1, 1, 1-trichloroethane, ether or alcohol to remove oils, waxes, dirt or any other material that may obscure the fiber characteristics. It may also be necessary to treat the fibers with 0.5 percent sodium hydroxide solution, as this aids in breaking up fiber bundles. Coir fibers shall be slowly boiled in 5 percent solution of sodium hydroxide for 2 to 4 hours and then washed. If it is necessary to remove dyes from the specimen which may interfere with the identification, they may be removed by any procedure that does not damage the fiber or change any of its characteristics. The specimen shall then be dried.

5.2 Manila and sisal. In the preparation of manila and sisal, a small portion of the cleaned fiber shall be further prepared as follows: One end of a bundle containing two or three dozen of the cleaned fibers shall be immersed in a gently boiling 5 percent solution of nitric acid for 7 minutes. The heated end of the fiber bundle shall then be washed under the cold water tap for about 30 seconds.

5.3 Coir. In the preparation of coir, a small portion of the cleaned fiber after being boiled in 5 percent solution of sodium hydroxide and washed, shall be macerated in the mortar until the fiber cells are well separated. These cells shall be mounted on a microscope slide and examined under the microscope.

5.4 The remaining portion of the specimen shall be placed in a porcelain crucible and ashed in the muffle furnace at 932°F (500°C). Temperatures higher than 932°F (500°C) shall not be used. When the ash is free of carbon, the crucible shall be removed from the furnace, cooled and a portion of the ash shall be placed on a slide, dispersed in water, and examined under the microscope.

5.5 Identification.

5.5.1 Manila fibers. Manila fibers are colored bright orange when heated with boiling 5 percent solution of nitric acid. The microscopic appearance of manila ash is characterized by the presence of siliceous stigmata, flat rectangular glass-like inclusions with a dimple in one surface. Although often found singly, they develop as strings in the fibers (Figure 1240A).

5.5.2 Sisal fibers. Sisal fibers are colored a pale yellow when heated with boiling 5 percent solution of nitric acid. The microscopic appearance of sisal ash is characterized by the presence of slightly curved calcium oxalate crystals. These crystals are often broken in the dispersal into rod-shaped pieces and curved, pointed particles (Figure 1240B).

METHOD 1240

5.5.3 Coir fibers. Coir fiber cells are short and stiff, being from 0.4 to 1 mm in length and from 12 to 14 micrometers in diameter. The cell wall is thick and the lumen has an irregularly indented outline. The cell ends terminate suddenly and are not sharp. Cross sections help to confirm the identification of coir. The fiber ash consists of small rounded siliceous bodies, often described as "yeast-shaped" (Figure 1240C).

6. REPORT

6.1 The presence or absence of manila, sisal or coir shall be reported.

6.2 If fibers other than the fiber being identified are present, the presence of other fibers shall also be reported.



Figure 1240A- MANILA

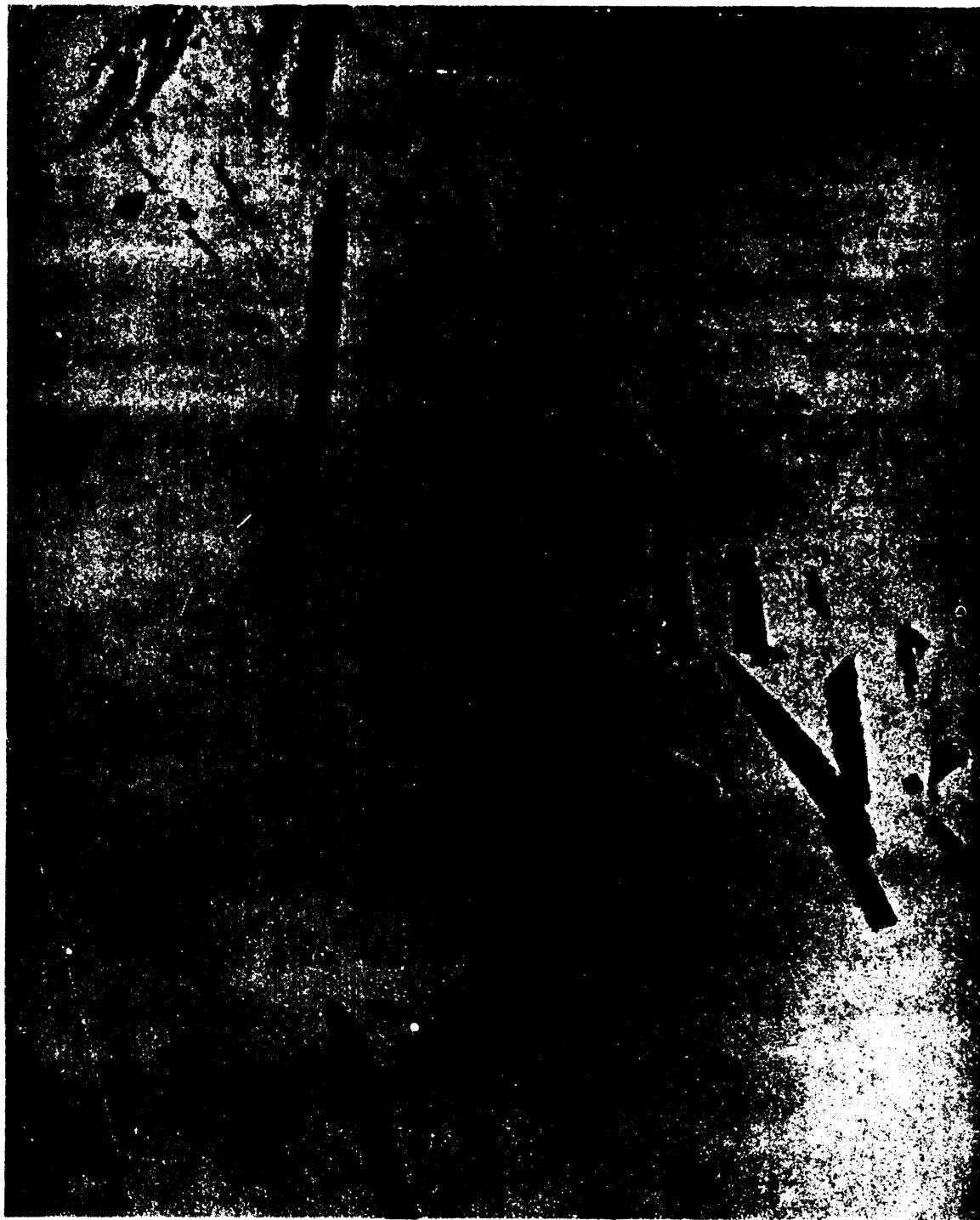

Figure 1240B - SISAL



Figure 1240C - COIR FIBER CELLS

IDENTIFICATION OF ASBESTOS

1. SCOPE

1.1 This method is intended for distinguishing asbestos from other fibers.

2. TEST SPECIMEN

2.1 The specimen shall be representative of the sample unit. If there is any evidence of nonhomogeneity, the specimen shall be composed of each variable portion.

3. NUMBER OF DETERMINATIONS

3.1 Unless otherwise specified in the procurement document, one specimen shall be tested from each sample unit. If fibers or yams dyed different colors are in the lot, at least two specimens of each color shall be taken for test.

4. APPARATUS AND REAGENTS

4.1 Apparatus.

4.1.1 Reference standard. At least one authentic sample of commercial asbestos fiber shall be kept on hand as a reference standard.

4.1.2 Microscope and accessories. The apparatus for microscopic examination shall consist of a compound microscope, dissecting needles, glass slides, cover glasses, and a cross-sectioning device. The microscope shall be equipped to permit examination of magnifications ranging from 100x to 500X.

4.1.3 Blotter.4.2 Reagents.

4.2.1 Herzberg's stain. The Herzberg's stain shall be prepared as follows:

4.2.1.1 Solution A. Zinc chloride solution at 1.80 specific gravity at 28°C made by adding 25 ml of distilled water to 50 g of dry CP Zinc chloride (fused sticks in sealed bottles, or crystals).

4.2.1.2 Solution B. 0.25 g of CP iodine and 5.25 g of CP potassium iodide dissolved in 12.5 ml of distilled water.

METHOD 1400

4.2.1.3 Stain. Mix 25 ml of solution A, measured at 20°C with solution B. Pour into a narrow cylinder and let stand until clear (12 to 24 hours). Decant the supernatant liquid into an amber-colored-glass-stoppered bottle and add a piece of iodine to the solution. Avoid undue exposure to light and air.

5. PROCEDURE

5.1 Preparation of specimen. The specimen shall be washed in or extracted with 1,1,1-trichloroethane, ether or alcohol to remove oils, waxes, dirt or any other material that may obscure the fiber characteristics. If it is necessary to remove dyes from the specimen which may interfere with the identification, they may be removed by any procedure that does not damage the fiber or change any of its characteristics. The specimen shall then be dried.

5.2 Mounting of specimen. At least a dozen fibers shall be placed on a slide. The fibers shall be immersed in three or four drops of Herzberg's stain, covered with a cover glass in such a manner as to avoid air bubbles, allowed to stand for 1 or 2 minutes, and the surplus stain then drained off by tipping the slide edgewise on a blotter.

5.3 Microscopic examination. The microscopic examination of the prepared slide shall be made with transmitted light at a magnification of 100X. If this magnification is not sufficient for positive identification, a higher magnification shall be used. The microscopic appearance of the specimen shall be compared with the reference standard prepared in the same manner as the specimen.

5.4 Identification. Asbestos is a fibrous silicate of magnesium and calcium, often in combination with aluminum and iron. In the vein or in large masses, the color is light gray, light green, gray, light yellow, or dark blue or brown if much iron is present. But in the fibrous condition it is usually white and the individual fibers, no matter how fine, seem to be composed of fine threads which are below the limit of microscopic resolution. Fiber bundles will break if bent at a sharp angle. Most asbestos fibers are stained a yellowish color by Herzberg's stain.

6. REPORT

6.1 The presence or absence of asbestos fiber shall be reported.

6.2 If fibers other than the fiber being identified are present, the presence of other fibers shall also be reported.

METHOD 1410
July 20, 1978

IDENTIFICATION OF GLASS

1. SCOPE

1.1 This method is intended for distinguishing glass fibers from asbestos and from organic fibers.

2. TEST SPECIMEN

2.1 The specimen shall be representative of the sample unit. If there is any evidence of nonhomogeneity, the specimen shall be composed of each variable portion.

3. NUMBER OF DETERMINATIONS

3.1 Unless otherwise specified in the procurement document, one specimen shall be tested from each sample unit. If fibers or yams dyed different colors are in the lot, at least two specimens of each color shall be taken for test.

4. APPARATUS AND REAGENTS

4.1 Apparatus.

4.1.1 Reference standard. At least one authentic sample of commercial glass fiber shall be kept on hand as a reference standard.

4.1.2 Microscope and accessories. The apparatus for microscopic examination shall consist of a compound microscope, dissecting needles, glass slides, cover glasses, and a cross-sectioning device. The microscope shall be equipped to permit examination of magnifications ranging from 100X to 500X.

4.1.3 Blotter.

4.2 Reagents.

4.2.1 Millon's reagent. Millon's reagent shall be prepared by dissolving 1 ml of mercury in 9 ml concentrated nitric acid (94 percent) and diluted with 10 ml of distilled water. This preparation shall be made under a hood. Since this reagent is unstable, it shall be freshly prepared.

4.2.2 Herzberg's stain. The Herzberg's stain shall be prepared as follows:

FED. TEST METHOD STD. NO. 191A

METHOD 1410

4.2.2.1 Solution A. Zinc chloride solution at 1.80 specific gravity at 28°C made by adding 25 ml of distilled water to 50 g of dry CP Zinc chloride (fused sticks in sealed bottles, or crystals).

4.2.2.2 Solution B. 0.25 g of CP iodine and 5.25 g of CP potassium iodide dissolved in 12.5 ml of distilled water.

4.2.2.3 Stain. Mix 25 ml of solution A, measured at 20°C with solution B. Pour into a narrow cylinder and let stand until clear (12 to 24 hours). Decant the supernatant liquid into an amber-colored glass-stoppered bottle and add a piece of iodine to the solution. Avoid undue exposure to light and air.

4.2.3 Solution of hydrofluoric acid.

5. PROCEDURE

5.1 Preparation of specimen. The specimen shall be washed in or extracted with 1, 1, 1-trichloroethane, ether or alcohol to remove oils, waxes, dirt or any other material that may obscure the fiber characteristics. If it is necessary to remove dyes from the specimen which may interfere with the identification, they may be removed by any procedure that does not damage the fiber or any of its characteristics. The specimen shall then be dried.

5.2 Mounting of specimen. At least a dozen fibers shall be placed on a slide. The fibers shall be immersed in three or four drops of Herzberg's stain, covered with a cover glass in such a manner as to avoid air bubbles, allowed to stand for 1 or 2 minutes, and the surplus stain then drained off by tipping the slide edgewise on a blotter.

5.3 Microscopic examination. The microscopic examination of the prepared slide shall be made with transmitted light at a magnification of 100X. If this magnification is not sufficient for positive identification, a higher magnification shall be used. The microscopic appearance of the specimen shall be compared with the reference standard prepared in the same reamer as the specimen.

5.4 Identification. Glass fibers are usually white or clear but may be any color. They break with a smooth fracture when bent sharply upon themselves. Microscopically, they are perfectly regular in diameter throughout their length. They have absolutely no smooth surface and are not affected by stains or ordinary reagents. Glass filaments are soluble in hydrofluoric acid. If there is evidence of the presence of other fibers or organic matter, the nature of these fibers may be determined by mounting in Millon's reagent or in Herzberg's stain.

6. REPORT

6.1 The presence or absence of glass fiber shall be reported.

6.2 If fibers other than the fiber being identified are present, the presence of other fibers shall also be reported.

IDENTIFICATION OF RAYON, VISCOSE

1. SCOPE

1.1 This method is intended for distinguishing viscose rayon from other man-made fibers and from animal, vegetable, and mineral fibers.

2. TEST SPECIMEN

2.1 The specimen shall be representative of the sample unit. If there is any evidence of nonhomogeneity, the specimen shall be composed of each variable portion.

3. NUMBER OF DETERMINATIONS

3.1 Unless otherwise specified in the procurement document, one specimen shall be tested from each sample unit. If fibers or yarns dyed different colors are in the lot, at least two specimens of each color shall be taken for test.

4. APPARATUS AND REAGENTS

4.1 Apparatus.

4.1.1 Reference standard. At least one authentic sample of commercial rayon shall be kept on hand as a reference standard.

4.1.2 Microscope and accessories. The apparatus for microscopic examination shall consist of a compound microscope, dissecting needles, glass slides, cover glasses, and a cross-sectioning device. The microscope shall be equipped to permit examination of magnifications ranging from 100X to 500X.

4.1.3 Blotter.4.2 Reagents.

4.2.1 Herzberg's stain. The Herzberg's stain shall be prepared as follows:

4.2.1.1 Solution A. Zinc chloride solution at 1.80 specific gravity at 28°C made by adding 25 ml of distilled water to 50 g of dry CP Zinc chloride (fused sticks in sealed bottles, or crystals).

4.2.1.2 Solution B. 0.25 g of CP iodine and 5.25 g of CP potassium iodide dissolved in 12.5 ml of distilled water.

METHOD 1500

4.2.1.3 Stain. Mix 25 ml of solution A, measured at 20°C with solution B. Pour into a narrow cylinder and let stand until clear (12 to 24 hours). Decant the supernatant liquid into an amber-colored-glass-stoppered bottle and add a piece of iodine to the solution. Avoid undue exposure to light and air.

5. PROCEDURE

5.1 Preparation of specimen. The specimen shall be washed in or extracted with 1,1,1-trichloroethane, ether or alcohol to remove oils, waxes, dirt or any other material that may obscure the fiber characteristics. If it is necessary to remove dyes from the specimen which may interfere with the identification, they may be removed by any procedure that does not damage the fiber or change any of its characteristics. The specimen shall then be dried.

5.2 Mounting of specimen. At least a dozen fibers shall be placed on a slide. The fibers shall be immersed in three or four drops of Herzberg's stain, covered with a cover glass in such a manner as to avoid air bubbles, allowed to stand for 1 or 2 minutes, and the surplus stain then drained off by tipping the slide edgewise on a blotter.

5.3 Microscopic examination. The microscopic examination of the prepared slide shall be made with transmitted light at a magnification of 100X. If this magnification is not sufficient for positive identification, a higher magnification shall be used. The microscopic appearance of the specimen shall be compared with the reference standard prepared in the same manner as the specimen.

5.4 Identification. Viscose rayon is identified under the microscope by the many longitudinal striations (Figure 1500). When mounted in Herzberg's stain, the viscose rayon filaments react to the stain slowly, first becoming pink or light purple in color and gradually becoming darker. Cut ends and bruised spots on the fibers take up the color much more rapidly, giving the fibers a mottled appearance at times.

6. REPORT

6.1 The presence or absence of viscose rayon fiber shall be reported.

6.2 If fibers other than the fiber being identified are present, the presence of other fibers shall also be reported.

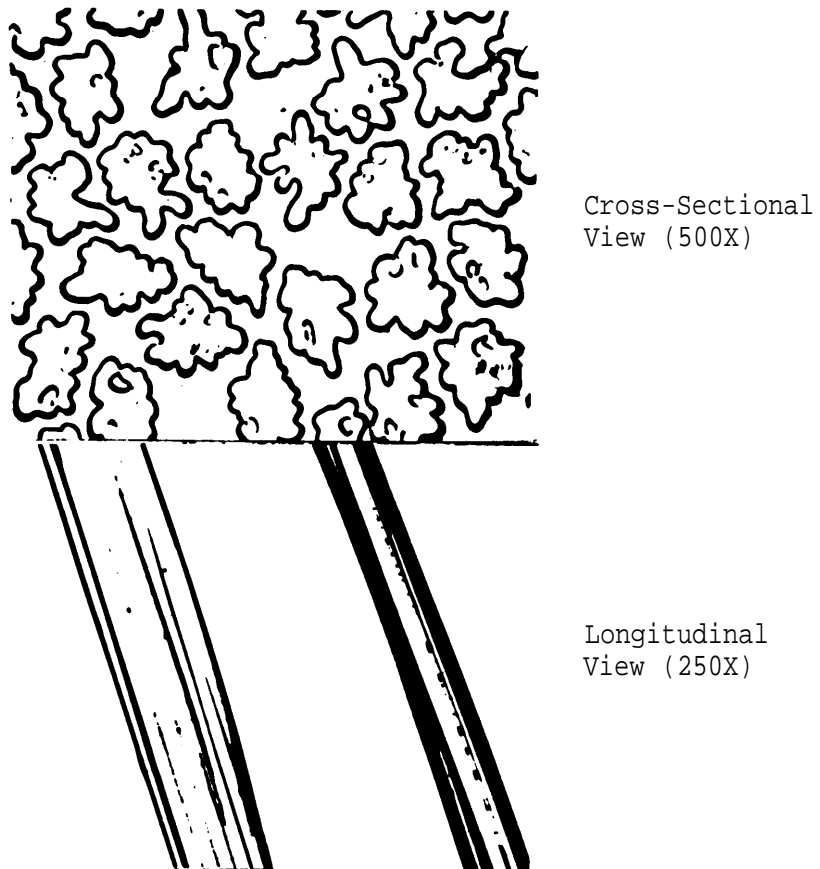

FIGURE 1500 - Rayon Fibers, Viscose

IDENTIFICATION OF RAYON, ACETATE

1. SCOPE

1.1 This method is intended for distinguishing acetate rayon from other man-made fibers and from animal, vegetable, and mineral fibers.

2. TEST SPECIMEN

2.1 The specimen shall be representative of the sample unit. If there is any evidence of nonhomogeneity, the specimen shall be composed of each variable portion.

3. NUMBER OF DETERMINATIONS

3.1 Unless otherwise specified in the procurement document, one specimen shall be tested from each sample unit. If fibers or yarns dyed different colors are in the lot, at least two specimens of each color shall be taken for test.

4. APPARATUS AND REAGENTS

4.1 Apparatus.

4.1.1 Reference standard. At least one authentic sample of commercial cellulose acetate shall be kept on hand as a reference standard.

4.1.2 Microscope and accessories. The apparatus for microscopic examination shall consist of a compound microscope, dissecting needles, glass slides, cover glasses, and a cross-sectioning device. The microscope shall be equipped to permit examination of magnifications ranging from 100X to 500X.

4.1.3 Blotter.4.2 Reagents.

4.2.1 Herzberg's stain. The Herzberg's stain shall be prepared as follows:

4.2.1.1 Solution A. Zinc chloride solution at 1.80 specific gravity at 28°C made by adding 25 ml of distilled water to 50 g of dry CP Zinc chloride (fused sticks in sealed bottles, or crystals).

4.2.1.2 Solution B. 0.25 g of CP iodine and 5.25 g of CP potassium iodide dissolved in 12.5 ml of distilled water.

METHOD 1510

4.2.1.3 Stain. Mix 25 ml of solution A, measured at 20°C with solution B. Pour into a narrow cylinder and let stand until clear (12 to 24 hours). Decant the supernatant liquid into an amber-colored-glass-stoppered bottle and add a piece of iodine to the solution. Avoid undue exposure to light and air.

4.2.2 Glacial acetic acid.

5. PROCEDURE

5.1 Preparation of specimen. The specimen shall be washed in or extracted with 1,1,1-trichloroethane, ether or alcohol to remove oils, waxes, dirt or any other material that may obscure the fiber characteristics. If it is necessary to remove dyes from the specimen which may interfere with the identification, they may be removed by any procedure that does not damage the fiber or change any of its characteristics. The specimen shall then be dried.

5.2 Mounting of specimen. At least a dozen fibers shall be placed on a slide. The fibers shall be immersed in three or four drops of Herzberg's stain, covered with a cover glass in such a manner as to avoid air bubbles, allowed to stand for 1 or 2 minutes, and the surplus stain then drained off by tipping the slide edge-wise on a blotter.

5.3 Microscopic examination. The microscopic examination of the prepared slide shall be made with transmitted light at a magnification of 100X. If this magnification is not sufficient for positive identification, a higher magnification shall be used. The microscopic appearance of the specimen shall be compared with the reference standard prepared in the same manner as the specimen.

5.4 Identification. Acetate rayon filaments have a few longitudinal striations, but they are not so numerous and usually not so conspicuous as those of viscose rayon. Sometimes the filaments have dumbbell-shaped cross sections, giving them the appearance, when viewed longitudinally, of having well-defined canals. Acetate rayon is quickly colored a bright yellow, swells rapidly, and is gradually dissolved in Herzberg's stain. Acetate rayon dissolves quickly in cold glacial acetic acid but does not dissolve in cuprammonium solution.

6. REPORT

6.1 The presence of absence of acetate rayon fiber shall be reported.

6.2 If fibers other than the fiber being identified are present, the presence of other fibers shall also be reported.

METHOD 1520
July 20, 1978

IDENTIFICATION OF RAYON, CUPRAMMONIUM

1. SCOPE

1.1 This method is intended for distinguishing cuprammonium rayon from other man-made fibers and from animal, vegetable, and mineral fibers.

2. TEST SPECIMEN

2.1 The specimen shall be representative of the sample unit. If there is any evidence of nonhomogeneity, the specimen shall be composed of each variable portion.

30 NUMBER OF DETERMINATIONS

3.1 Unless otherwise specified in the procurement document, one specimen shall be tested from each sample unit. If fibers or yarns dyed different colors are in the lot, at least two specimens of each color shall be taken for test.

4. APPARATUS AND REAGENTS

4.1 Apparatus.

4.1.1 Reference standard. At least one authentic sample of commercial cuprammonium rayon shall be kept on hand as a reference standard.

4.1.2 Microscope and accessories. The apparatus for microscopic examination shall consist of a compound microscope, dissecting needles, glass slides, cover glasses, and a cross-sectioning device. The microscope shall be equipped to permit examination of magnifications ranging from 100X to 500X.

4.1.3 Blotter.

4.2 Reagents.

4.2.1 Herzberg's stain. The Herzberg's stain shall be prepared as follows:

4.2.1.1 Solution A. Zinc chloride solution at 1.80 specific gravity at 28°C made by adding 25 ml of distilled water to 50 g of dry CP Zinc chloride (fused sticks in sealed bottles, or crystals).

4.2.1.2 Solution B. 0.25 g of CP iodine and 5.25 g of CP potassium iodide dissolved in 12.5 ml of distilled water.

FED-STD-191A

METHOD 1520

4.2.1.3 Stain. Mix 25 ml of solution A, measured at 20°C with solution B. Pour into a narrow cylinder and let stand until clear (12 to 24 hours). Decant the supernatant liquid into an amber-colored-glass-stoppered bottle and add a piece of iodine to the solution. Avoid undue exposure to light and air.

5. PROCEDURE

5.1 Preparation of specimen. The specimen shall be washed in or extracted with 1,1,1-trichloroethane, ether or alcohol to remove oils, waxes, dirt or any other material that may obscure the fiber characteristics. If it is necessary to remove dyes from the specimen which may interfere with the identification, they may be removed by any procedure that does not damage the fiber or change any of its characteristics. The specimen shall then be dried.

5.2 Mounting of specimen. At least a dozen fibers shall be placed on a slide. The fibers shall be immersed in three or four drops of Herzberg's stain, covered with a cover glass in such a manner as to avoid air bubbles, allowed to stand for 1 or 2 minutes, and the surplus stain then drained off by tipping the slide edgewise on a blotter.

5.3 Microscopic examination. The microscopic examination of the prepared slide shall be made with transmitted light at a magnification of 100X. If this magnification is not sufficient for positive identification, a higher magnification shall be used. The microscopic appearance of the specimen shall be compared with the reference standard prepared in the same manner as the specimen.

5.4 Identification. Cuprammonium rayon is smooth, without longitudinal striations, and the cross sections are almost circular. The filaments of cuprammonium rayon are usually smaller in diameter than viscose rayon (Figure 1520). The filaments react quickly with Herzberg's stain and are colored purple; the purple soon becomes so dense as to make the filaments nontransparent.

6. REPORT

6.1 The presence or absence of cuprammonium rayon filaments shall be reported.

6.2 If fibers other than the fiber being identified are present, the presence of other fibers shall also be reported.

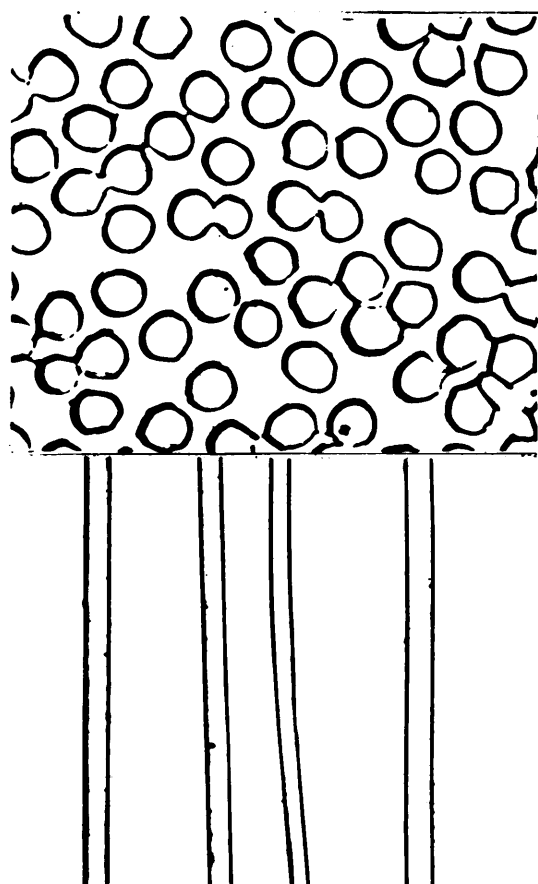

Cross-Sectional
View (500x)

Longitudinal
View (250X)

FIGURE 1520 - Rayon Fibers, Cuprammonium

IDENTIFICATION OF NYLON

1. SCOPE

1.1 This method is intended for distinguishing nylon filaments from other man-made filaments and from animal, vegetable, and mineral fibers.

2. TEST SPECIMEN

2.1 The specimen shall be representative of the sample unit. If there is any evidence of nonhomogeneity, the specimen shall be composed of each variable portion.

3. NUMBER OF DETERMINATIONS

3.1 Unless otherwise specified in the procurement document, one specimen shall be tested from each sample unit. If fibers or yams dyed different colors are in the lot, at least two specimens of each color shall be taken for test.

4. APPARATUS AND REAGENTS

4.1 Apparatus.

4.1.1 Reference standard. At least one authentic sample of commercial nylon shall be kept on hand as a reference standard.

4.1.2 Microscope and accessories. The apparatus for microscopic examination shall consist of a compound microscope, dissecting needles, glass slides, cover glasses, and a cross-sectioning device. The microscope shall be equipped to permit examination of magnifications ranging from 100X to 500X.

4.1.3 Blotter.4.2 Reagents.

4.2.1 Herzberg's stain. The Herzberg's stain shall be prepared as follows:

4.2.1.1 Solution A. Zinc chloride solution at 1.80 specific gravity at 28°C made by adding 25 ml of distilled water to 50 g of dry CP Zinc chloride (fused sticks in sealed bottles, or crystals).

4.2.1.2 Solution B. 0.25 g of CP iodine and 5.25 g of CP potassium iodide dissolved in 12.5 ml of distilled water.

METHOD 1530

4.2.1.3 Stain. Mix 25 ml of solution A, measured at 20°C with solution B. Pour into a narrow cylinder and let stand until clear (12 to 24 hours). Decant the supernatant liquid into an amber-colored-glass-stoppered bottle and add a piece of iodine to the solution. Avoid undue exposure to light and air.

4.2.1.4 Solution of 88 percent formic acid.

5. PROCEDURE

5.1 Preparation of specimen. The specimen shall be washed in or extracted with 1,1,1-trichloroethane, ether or alcohol to remove oils, waxes, dirt or any other material that may obscure the fiber characteristics. If it is necessary to remove dyes from the specimen which may interfere with the identification, they may be removed by any procedure that does not damage the fiber or change any of its characteristics. The specimen shall then be dried.

5.2 Mounting of specimen. At least a dozen fibers shall be placed on a slide. The fibers shall be immersed in three or four drops of Herzberg's stain, covered with a cover glass in such a manner as to avoid air bubbles, allowed to stand for 1 or 2 minutes, and the surplus stain then drained off by tipping the slide edgewise on a blotter.

5.3 Microscopic examination. The microscopic examination of the prepared slide shall be made with transmitted light at a magnification of 100X. If this magnification is not sufficient for positive identification, a higher magnification shall be used. The microscopic appearance of the specimen shall be compared with the reference standard prepared in the same manner as the specimen.

5.4 Identification. Nylon filaments have smooth surfaces with no longitudinal or cross-markings. The diameter of each filament is very uniform and the cross section is circular, or nearly so, for all filaments (Figure 1530). The filaments are colored canary yellow to a dark yellow by Herzberg's stain. Nylon filaments dissolve rapidly in cold 88 percent formic acid.

6. REPORT

6.1 The presence or absence of nylon filaments shall be reported.

6.2 If fibers other than the fiber being identified are present, the presence of other fibers shall also be reported.

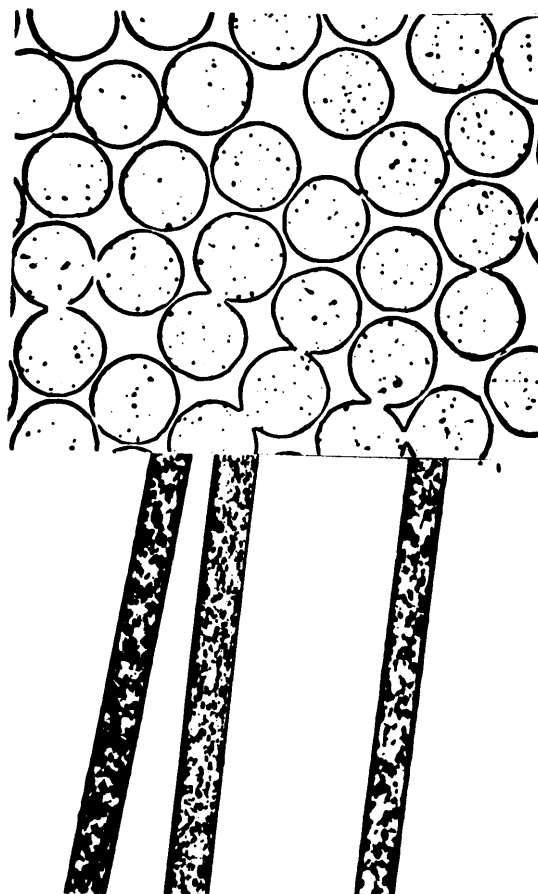

Cross-Sectional
View (500X)

Longitudinal
View (250X)

FIGURE 1530 - Nylon Fibers

MELTING POINT OF SYNTHETIC FIBERS

1. SCOPE

1.1 This method is intended for determining the melting point of thermoplastic fibers, threads, or yarns containing a single type of fiber.

2. TEST SPECIMEN

2.1 Unless otherwise specified in the procurement document, the test specimen shall be 3 to 4 mg of the material prepared as specified in 5.1.

3. NUMBER OF DETERMINATIONS

3.1 Unless otherwise specified in the procurement document, two specimens shall be tested from each sample unit.

4. APPARATUS AND REAGENTS

4.1 Apparatus.

4.1.1 An electrically heated stage, having a circular depression large enough to insert a micro cover glass.

4.1.1.1 A variable transformer controlling the rate of heat input into the stage.

4.1.1.2 Armored stem thermometers. One thermometer with a range of 20° to 160°C, accurate to 1/2°C. One thermometer with a range from 150° to 300°C, accurate to 1°C.

4.1.2 Low-powered magnifying glass.4.1.3 Two micro cover glasses.

4.1.4 Spatula, pick needle, or other instrument for applying pressure to the cover glasses.

METHOD 1534

4.1.5 Soxhlet extraction apparatus.

4.2 Reagents.

4.2.1 Chloroform, U. S. P.

4.2.2 U. S. Pharmacopoeia reference standards for melting point or other pure materials for calibrating the apparatus.

5. PROCEDURE

5.1 Preparation of specimen. The specimen shall be extracted with chloroform for a minimum of 20 extractions in a Soxhlet extractor and dried. The specimen shall then be cut into lengths of 1/16 inch (2 mm) or less.

5.2 Preparation of apparatus. The apparatus shall be calibrated by determining the melting point of a pure material of known melting point (see 7.2). The melting point of the pure material shall be in the range or the melting point of the fiber being tested. The value obtained shall agree within $\pm 1^{\circ}\text{C}$ of the known value.

5.3 If the approximate melting point of the specimen is not known before testing, it shall be determined by a trial run.

5.4 In subsequent determinations immediately following the trial run or initial determination, the stage in each case shall be cooled to approximately 50°C below the expected melting point, before the specimen is placed for testing.

5.5 The specimen shall be placed in a small mound on a cover glass and covered with another cover glass. The 2 cover glasses shall be pressed together gently but firmly, and placed in the circular depression on the stage. The temperature of the stage shall be raised with some rapidity to within 15°C of the expected melting point, and thereafter at a rate of 3° to 4°C per minute. At this rate of temperature rise, a slight pressure shall be applied on the upper glass cover by pressing with a spatula, pick needle, or other instrument, so that the complete fiber is in contact with the cover glass.

METHOD 1534

5.6 The specimen shall be observed with the aid of a magnifying glass, and the melting point taken as the temperature at which flow of the specimen is observed. At the observed melting point, the temperature shall be read to the nearest degree C.

6. REPORT

6.1 The melting point of the sample unit shall be the average of the results obtained from the specimens tested, and shall be reported to the nearest degree C.

6.2 Each individual value utilized in expressing the final result shall be reported.

7. NOTES

7.1 Apparatus of the type described in this method may be obtained from:

- (1) The Fisher Scientific Company, 711 Forbes Avenue, Pittsburgh, PA 15219, and is known as the Fisher-Jones Melting Point Apparatus
- (2) Arthur H. Thomas Company, Vine St. at Third, P.O. Box 779, Philadelphia, PA 19105
- (3) Will Scientific Instruments, Inc., Rochester, NY 14603

7.2 Six standards for use in calibrating melting point apparatus may be obtained from the U. S. Pharmacopoeia Reference Standards, 46 Park Avenue, New York, NY 10016.

IDENTIFICATION OF VINYLIDENE CHLORIDE FIBERS

1. SCOPE

1.1 This method is intended for distinguishing vinylidene chloride from other man-made filaments and from animal, vegetable, and mineral fibers.

2. TEST SPECIMEN

2.1 The specimen shall be representative of the sample unit. If there is any evidence of nonhomogeneity, the specimen shall be composed of each variable portion.

3. NUMBER OF DETERMINATIONS

3.1 Unless otherwise specified in the procurement document, one specimen shall be tested from each sample unit. If fibers or yarns dyed different colors are in the lot, at least two specimens of each color shall be taken for test.

4. APPARATUS AND REAGENTS

4.1 Apparatus.

4.1.1 Reference standard. At least one authentic sample of commercial vinylidene chloride shall be kept on hand as a reference standard.

4.1.2 Microscope and accessories. The apparatus for microscopic examination shall consist of a compound microscope, dissecting needles, glass slides, cover glasses, and a cross-sectioning device. The microscope shall be equipped to permit examination of magnifications ranging from 100X to 500X.

4.1.3 Blotter.4.2 Reagents.

4.2.1 Herzberg's stain. The Herzberg's stain shall be prepared as follows:

4.2.1.1 Solution A. Zinc chloride solution at 1.80 specific gravity at 28°C made by adding 25 ml of distilled water to 50 g of dry CP Zinc chloride (fused sticks in sealed bottles, or crystals).

4.2.1.2 Solution B. 0.25 g of CP iodine and 5.25 g of CP potassium iodide dissolved in 12.5 ml of distilled water.

METHOD 1540

4.2.1.3 Stain. Mix 25 ml of solution A, measured at 20°C with solution B. Pour into a narrow cylinder and let stand until clear (12 to 24 hours). Decant the supernatant liquid into an amber-colored-glass-stoppered bottle and add a piece of iodine to the solution. Avoid undue exposure to light and air.

4.2.2 Solution of tetrachlorethylene.

5. PROCEDURE

5.1 Preparation of specimen. The specimen shall be washed in or extracted with 1,1,1-trichloroethane, ether or alcohol to remove oils, waxes, dirt or any other material that may obscure the fiber characteristics. If it is necessary to remove dyes from the specimen which may interfere with the identification, they may be removed by any procedure that does not damage the fiber or change any of its characteristics. The specimen shall then be dried.

5.2 Mounting of specimen. At least a dozen fibers shall be placed on a slide. The fibers shall be immersed in three or four drops of Herzberg's stain, covered with a cover glass in such a manner as to avoid air bubbles, allowed to stand for 1 or 2 minutes, and the surplus stain then drained off by tipping the slide edgewise on a blotter.

5.3 Microscopic examination. The microscopic examination of the prepared slide shall be made with transmitted light at a magnification of 100X. If this magnification is not sufficient for positive identification, a higher magnification shall be used. The microscopic appearance of the specimen shall be compared with the reference standard prepared in the same manner as the specimen.

5.4 Identification. Vinylidene chloride filaments are smooth rod shaped filaments similar to nylon and without striations or transverse markings. The diameter of each filament is uniform and the cross section circular. The filaments are unaffected by organic acids and alkalies but are dissolved by polychlorinated hydrocarbons such as tetrachlorethylene.

6. REPORT

6.1 The presence or absence of vinylidene chloride filaments shall be reported.

6.2 If fibers other than the fiber being identified are present, the presence of other fibers shall also be reported.

METHOD 1550
July 20, 1978

IDENTIFICATION OF VINYL CHLORIDE-ACETATE COPOLYMER FIBERS

1. SCOPE

1.1 This method is intended for distinguishing vinyl chloride-acetate copolymers from the natural fibers and from other man-made fibers but not other types of vinyl fibers.

2. TEST SPECIMEN

2.1 The specimen shall be representative of the sample unit. If there is any evidence of nonhomogeneity, the specimen shall be composed of each variable portion.

3. NUMBER OF DETERMINATIONS

3.1 Unless otherwise specified in the procurement document, one specimen shall be tested from each sample unit. If fibers or yarns dyed different colors are in the lot, at least two specimens of each color shall be taken for test.

4. APPARATUS AND REAGENTS

4.1 Apparatus.

4.1.1 Reference standard. At least one authentic sample of commercial vinyl chloride-acetate copolymer shall be kept on hand as a reference standard.

4.1.2 Microscope and accessories. The apparatus for microscopic examination shall consist of a compound microscope, dissecting needles, glass slides, cover glasses, and a cross-sectioning device. The microscope shall be equipped to permit examination of magnifications ranging from 100X to 500X.

4.1.3 Blotter.

4.2 Reagents.

4.2.1 Herzberg's stain. The Herzberg's stain shall be prepared as follows:

4.2.1.1 Solution A. Zinc chloride solution at 1.80 specific gravity at 28°C made by adding 25 ml of distilled water to 50 g of dry CP Zinc chloride (fused sticks in sealed bottles, or crystals).

4.2.1.2 Solution B. 0.25 g of CP iodine and 5.25 g of CP potassium iodide dissolved in 12.5 ml of distilled water.

METHOD 1550

4.2.1.3 Stain. Mix 25 ml of solution A, measured at 20°C with solution B. Pour into a narrow cylinder and let stand until clear (12 to 24 hours). Decant the supernatant liquid into an amber-colored-glass-stoppered bottle and add a piece of iodine to the solution. Avoid undue exposure to light and air.

4.2.2 Acetone.

4.2.3 Glacial acetic acid.

5. PROCEDURE

5.1 Preparation of specimen. The specimen shall be washed in or extracted with 1,1,1-trichloroethane, ether or alcohol to remove oils, waxes, dirt or any other material that may obscure the fiber characteristics. If it is necessary to remove dyes from the specimen which may interfere with the identification, they may be removed by any procedure that does not damage the fiber or change any of its characteristics. The specimen shall then be dried.

5.2 Mounting of specimen. At least a dozen fibers shall be placed on a slide. The fibers shall be immersed in three or four drops of Herzberg's stain, covered with a cover glass in such a manner as to avoid air bubbles, allowed to stand for 1 or 2 minutes, and the surplus stain then drained off by tipping the slide edgewise on a blotter.

5.3 Microscopic examination. The microscopic examination of the prepared slide shall be made with transmitted light at a magnification of 100X. If this magnification is not sufficient for positive identification, a higher magnification shall be used. The microscopic appearance of the specimen shall be compared with the reference standard prepared in the same manner as the specimen.

5.4 Identification. Vinyl chloride-acetate copolymer filaments have smooth surfaces without striations or transverse markings but have a false lumen. The cross sectional area is dumbbell to slipper shape in form. Vinyl chloride-acetate copolymers dissolve rapidly in cold acetone but not in cold glacial acetic acid.

6. REPORT

6.1 The presence or absence of vinyl chloride-acetate copolymers shall be reported.

6.2 If fibers other than the fiber being identified are present, the presence of other fibers also be reported.

IDENTIFICATION OF SYNTHETIC FIBERS BY GENERIC CLASS

1. SCOPE

1.1 This method is intended for determining the identification of synthetic fibers as a generic class. It is not intended for use on blends of fibers that cannot be separated before identification, nor is it intended for the identification of the various fibers within the same generic class. In the interests of standardization of testing requirements, it is recommended that this method not be used in procurement documents.

2. TEST SPECIMEN

2.1 The specimen shall be a representative portion of fibers from the sample unit.

3. NUMBER OF DETERMINATIONS

3.1 Unless otherwise specified in the procurement document, one specimen shall be tested from each sample unit.

4. APPARATUS AND REAGENTS

4.1 Apparatus.

4.1.1 (a) A compound microscope with an eyepiece and substage condenser for the attachment of polarizing discs, or (b) a polarizing microscope.

4.1.2 Microscope illuminator.4.1.3 Hydrometer.4.1.4 Glass slides4.1.5 Cover slips.4.2 Reagents.4.2.1 Anthrone (9, 10-dihydro-9-oxoanthracene).4.2.2 Methylene chloride/ethanol (90/10 by volume).

METHOD 1600

- 4.2.3 Mineral oil.
- 4.2.4 Monochlorobenzene.
- 4.2.5 Cassia oil.
- 4.2.6 Benzyl alcohol.
- 4.2.7 Sulfuric acid (cone. 98 percent).
- 4.2.8 Toluene.
- 4.2.9 Methylene chloride.

4.2.10 Density liquids. Four liquids of known density, 1.0, 1.2, 1.4, and 1.7, are required. For 1.0, water with a few drops of wetting agent added to reduce surface tension, so that fibers with water-resistant finishes will be wetted, is satisfactory. For 1.2, 1,1,1-trichloroethane and benzene are mixed to the specified density in a graduated cylinder using a hydrometer. For 1.4 and 1.7, bromoform and 1,1,1-trichloroethane are mixed in the same manner. It is convenient to keep the solutions in glass cylinders suitable for accepting a hydrometer, so that the density can be easily rechecked.

5. PROCEDURE

5.1 Anthrone test. The specimen of fiber shall be placed in a few milliliters of the concentrated sulfuric acid in which several crystals of anthrone have been dissolved, and several drops of water shall be added. The presence of cellulosic fibers is indicated by an intense opaque blue color. If cellulosic finishes are present on synthetic fibers, the solution may develop a blue tint. This color, however, is easily distinguished from the intense opaque blue color of the positive test. If the test is positive, separate portions of the test specimen shall be placed in a few milliliters of benzyl alcohol at 122°F (50°C) and a few milliliters of the methylene chloride-ethanol solution at room temperature. If the fiber is insoluble in benzyl alcohol but not in the methylene chloride-ethanol solution, the fiber is triacetate. If the fiber is soluble in both solvents, the fiber is acetate. If the fiber is insoluble in both solvents, the fiber is rayon. (It should be noted that cotton, which is readily recognized under the microscope, is also insoluble in both.)

5.2 Density range of fibers. If the anthrone test is negative, i.e., an intense opaque blue color does not develop, the density range of the fiber shall be determined. The specimen of fiber, from which any finish has been removed, shall be tied in a knot if the form of the specimen permits. The excess fiber shall be cut off close to the knot, and the knot placed in boiling benzene to remove any entrapped air. By means of tweezers, it shall then be placed below the surface of the liquid of density 1.0 and released. Whether the fiber floats or sinks shall be recorded. This procedure shall be repeated until the fiber specimen floats in one of the liquids or sinks in all. The density range of the specimen shall be recorded as less than 1.0 if it floats on the surface of that liquid; between 1.0 and 1.2 if it sinks to the bottom of the 1.0 density liquid and floats on the surface of the 1.2 density liquid; etc.

5.3 Fibers in the density range less than 1.0 are olefins.

5.4 Examination for polar colors. When examining the fibers for polar colors, one disc shall be placed in the eyepiece of the microscope and the other in the substage condenser. Examination shall be made at an angle of 45 degrees to the plane of vibration of the crossed polarizers, which is the angle at which the fibers exhibit the highest color.

5.5 Parallel examination. Those fibers which exhibit no polar color except low order gray or silver shall be examined parallel, i.e., under the microscope equipped with the eyepiece analyzer only and with the long axis of the fibers parallel to the plane of vibration. The direction of movement of the Becke line, i.e., the bright line caused by the reflection and refraction of light at the margin between the fiber and immersion liquid, shall be noted as the microscope is focused up.

5.6 Nylon, acrylic, and nitryl fibers. Fibers in the density range of 1.0 to 1.2 are nylon, acrylic, and nitryl. Fibers in this density range shall be mounted in mineral oil and examined for polar colors as described in 5.4. Those exhibiting no polar colors except low order gray or silver shall be mounted in toluene and examined parallel as described in 5.5. If the Becke line moves toward the liquid, the specimen is nitryl. If it moves toward the fiber, it is an acrylic.

5.7 Polyester, modacrylic, vinal, and vinyon fibers. Fibers in the density range 1.2 to 1.4 are polyester, modacrylic, vinal, or vinyon. The specimen of fiber shall be mounted in mineral oil and examined for polar colors as described in 5.4. Those exhibiting no polar colors except low order gray or silver are modacrylic and vinyon. The specimen of fiber shall be placed in methylene chloride at room temperature. If the fiber is soluble, it is vinyon. If the fiber is insoluble, it is modacrylic.

METHOD 1600

5.8 Fibers in the density range 1.4 to 1.7 are saran.

5.9 Glass and fluorocarbons. Fibers in a density range greater than 1.7 are glass and fluorocarbons. The specimen shall be mounted in toluene and examined as described in 5.5. If the Becke moves toward the fiber it is glass. If it moves toward the liquid it is fluorocarbon.

6. REPORT

6.1 The presence or absence of the specified synthetic fiber shall be reported by generic class.

OUTLINE OF IDENTIFICATION METHOD

Anthrone Positive

	benzyl alcohol	methylene chloride ethanol	
	soluble	soluble	ACETATE
Cellulosics	soluble	insoluble	TRIACETATE
	insoluble	insoluble	RAYON
Anthrone Negative check density range			
DENSITY RANGE			
less than 1.0			OLEFIN
1.0 to 1.2	Polar Colors Present		
	Polar Colors Absent	fiber	ACRYLIC
	mount in toluene Becke line to	liquid	NYTRIL
1.2 to 1.4	Polar Colors Present	fiber	POLYESTER
	mount in cassia Becke line to	liquid	VINAL
	oil		
	Polar Colors Absent		
	soluble in methylene chloride		VINYON
	insoluble in methylene chloride		MODACRYLIC
1.4 to 1.7		fiber	SARAN
higher than 1.7	mount in toluene Becke line to	liquid	GLASS
			FLUOROCARBON

METHOD 1700
July 20, 1978

IDENTIFICATION OF DYES ON ANIMAL FIBERS

1. SCOPE

1.1 This method is intended for determining the type of dyestuff on wool or silk fibers. It may also be used to determine the type of dye applied to blends of animal and vegetable fibers.

2. TEST SPECIMEN

2.1 The specimen shall be about 5 g of the textile material, cut into 1/4 inch (6 mm) squares, if a cloth.

3. NUMBER OF DETERMINATIONS

3.1 Unless otherwise specified in the procurement document, one specimen shall be tested from each sample unit. If fibers or yarns dyed different colors are in the lot, at least two specimens of each color shall be taken for test.

4. APPARATUS AND REAGENTS

4.1 Apparatus.

4.1.1 Filter paper Whatman No. 42.

4.1.2 Funnel.

4.1.3 Silica crucible.

4.1.4 Test tubes.

4.1.5 Bunsen burner.

4.1.6 Sand bath.

4.1.7 Beaker 200 ml.

4.2 Reagents.

4.2.1 Bleached and mercerized cotton cloth.

4.2.2 Chrome-mordanted wool cloth.

4.2.3 Scoured wool cloth.

FED. TEST METHOD STD. NO. 191A

METHOD 1700

4.2.4 Ethyl alcohol (70 percent).

4.2.5 Fusion mixture. Equal parts of potassium nitrate CP and anhydrous sodium carbonate.

4.2.6 Ammonium hydroxide solution. Ammonium hydroxide solution consisting of 2 ml NH_3OH , specific gravity 0.899 per 1,000 ml of solution.

4.2.7 Ethylene diamine (60 to 70 percent).

4.2.8 Acetic acid, glacial.

4.2.9 Sodium chloride.

4.2.10 Potassium persulfate (1 percent solution).

4.2.11 Sodium sulfate.

4.2.12 Sodium hydroxide (10 percent solution).

4.2.13 Sodium acetate (10 percent solution).

4.2.14 Nitric-hydrochloric acid solution. 1 part by volume of concentrated nitric acid to 3 parts of concentrated hydrochloric acid.

5. PROCEDURE

5.1 Preparation of specimen. The entire specimen shall be washed free of loose dyestuff with hot water. The solution shall be saved for further testing if the specimen is materially changed in shade. The solution shall be concentrated and the dyestuff applied to a 1 inch (25 mm) piece of scoured wool by standard dyeing procedures.

5.2 Test for presence of basic dye. A few pieces of the original dyed material shall be placed in a test tubes covered with the 10 Percent sodium hydroxide solution, and boiled for 1 minute. The solution shall then be cooled to room temperature and extracted by shaking with 5 ml of ethyl ether. The ether extract shall be decanted into a clean test tube and an equal volume of cold water added, followed by acidification with acetic acid. The basic color is shown by visible color-bleeding from the ether layer to the acidified water.

5.3 Test for presence of direct cotton dye. A few pieces of the original specimen shall be placed in a test tube, covered with a 2 percent ammonium hydroxide solution and boiled for 2 minutes. If the solution is colored, a few crystals of sodium chloride and a piece of mercerized cotton and scoured

METHOD 1700

wool approximately 1/4 inch (6 mm) square shall be added, the solution boiled for 1 minute, and allowed to cool to room temperature. If the cotton is deeply stained, the dye is of the direct cotton type. If the cotton is only slightly stained or not stained, and the wool is stained, the dyestuff is of the acid or mordant-acid type.

5.4 Test for presence of acid and mordant-acid dyes. The acid and mordant-acid dyes shall be differentiated by warming a piece of the original specimen in nitric-hydrochloric acid solution on a sand bath with constant stirring, until a dry residue is obtained. Tin, chromium, iron, and aluminum shall be identified if present by standard qualitative analytical procedures. If a mordant is present, the dye is of the mordant-acid type.

5.5 Test for presence of azoic (insoluble azo) dye. If the results of the previous tests were negative, four pieces of the original specimen shall be placed in 10 ml of ethylene diamine, heated for 2 minutes at 122°F (50°C), and allowed to cool to room temperature. The solution shall be decanted and separated into two portions. One portion shall be diluted with 15 ml of distilled water, acidified with acetic acid, allowed to cool to room temperature and filtered. The filtrate shall be removed (except for use in 5.6) and the filter paper washed with hot water. The presence of azoic dyes (insoluble azo) is indicated by a colored precipitate on the filter.

5.6 Test for presence of vat-type dye. The filtrate from 5.5 shall be oxidized with 5 ml of the potassium persulfate solution if azoic dyes are not present. The solution shall be allowed to set for 20 minutes, filtered, and washed with hot water. The presence of a colored precipitate indicates a vat-type dye.

5.7 Test for presence of mordant dye. If azoic dyes are not found (see 5.5) a few crystals of sodium sulfate and a piece of chrome-mordanted wool shall be added to the filtrate from 5.5. The solution and wool shall be boiled for a few minutes and allowed to cool to room temperature. The presence of mordant dyes is indicated by the color formed on the mordanted wool. This shall be confirmed by ashing a few pieces of the original specimen in the crucible and then fusing with the fusion mixture. This melt shall then be analyzed for aluminum, chromium, tin, and iron by standard qualitative analytical procedures.

6. REPORT

6.1 The type of dye shall be reported as basic, direct cotton, acid, mordant-acid, azoic (insoluble azo), vat or mordant. Whenever a mordant is present, the type of mordant shall be reported.

METHOD 2011
July 20, 1978

DIHYDROXYDICHLORODIPHENYL METHANE CONTENT,
CALORIMETRIC METHOD

1. SCOPE

1.1 This method is intended for determining the dihydroxydichlorodiphenyl methane (2, 2' methylene bis - 4 - chlorophenol) content of textile materials that have been treated with this compound-to prevent the formation of mildew.

2. TEST SPECIMEN

2.1 The specimen shall be a 1 g composite of the material cut into pieces approximately 1/8 inch (3 mm) square, and thoroughly mixed .

3. NUMBER OF DETERMINATIONS

3.1 Unless otherwise specified in the procurement document, two specimens shall be tested from each sample unit.

4. APPARATUS AND REAGENTS

4.1 Apparatus.

4.1.1 Spectrophotometer and accessories.

4.1.2 Volumetric flasks.

4.1.3 Microburette.

4.1.4 Beakers.

4.1.5 Pipettes.

4.1.6 Air oven.

4.1.7 Weighing bottle.

4.2 Reagents.

4.2.1 Crystallized 4-aminoantipyrine solution. A crystallized 4-aminoantipyrine solution, freshly prepared. The solution shall be prepared by dissolving 2 ± 0.001 g of 4-aminoantipyrine, m.p. $108^{\circ} - 109^{\circ}\text{C}$ in 100 ml of distilled water.

FED. TEST METHOD STD. NO. 191A

METHOD 2011

4.2.2 Potassium ferricyanide solution. A potassium ferricyanide solution, freshly prepared. The solution shall be prepared by dissolving 8 ± 0.001 g of reagent grade potassium ferricyanide in 100 ml of distilled water.

4.2.3 Sodium carbonate solution. A sodium carbonate solution, approximately 0.03 percent, pH between 10.4 and 10.6. Distilled water shall be used. The pH should be rechecked just prior to using.

4.2.4 Dihydroxydichlorodiphenyl methane (2, 2' methylene bis-4-chlorophenol) "G-4 Technical" or equal (see 7.1).

4.2.5 Buffer solution (distilled water), 2.47 percent boric acid, 0.4 percent sodium hydroxide, pH of 9.1 to 9.2 (adjust with additional sodium hydroxide, if necessary).

5. PROCEDURE

5.1 Preparation of specimen. Three samples not less than two g each shall be cut from the sample unit. One sample shall be cut from each edge of the sample unit but will not include the selvage except for narrow fabrics such as braid, tape or webbing when it is not practical or possible. The third sample shall be taken from the middle of the sample unit. No two samples shall contain the same warp or filling yams except narrow fabrics such as braid, tape or webbing when it is not practical or possible.

5.1.1 The three samples taken from the sample unit shall be cut in small pieces approximately 1/8 inch (3 mm) square and thoroughly mixed to form a composite sample. A one g test specimen shall be taken from the composite sample.

5.1.2 Weight of dry specimen. A specimen approximately 1 g taken from the composite sample shall be placed in a tared weighing bottle and dried in a circulating air oven at 221° to 230°F (105° to 110°C). The specimen shall be dried to a weight which is constant to ± 0.001 g.

5.2 Testing of specimen. The dried specimen shall be placed in a 200 ml beaker. Add to the beaker 50 ml of the 0.03 percent sodium carbonate solution and heat the contents to boiling. The solution shall be boiled gently for 5 minutes. The hot solution shall be decanted into a 200 ml volumetric flask. The extraction and boiling with sodium carbonate described above shall be repeated two more times and the extracts combined with the first extract in the 200 ml flask. The solution in the flask shall be diluted almost to the mark with the 0.03 percent sodium carbonate solution, using the diluent to wash the specimen two times. The flask and contents shall be permitted to cool to room temperature. The contents shall be diluted to the mark with the 0.03 percent sodium carbonate solution.

METHOD 2011

5.2.1 About 20 ml of the solution from 5.2 shall be filtered through a dry filter. A proper aliquot of this solution to provide a concentration that will fall within the points on the standard curve. The aliquot shall be placed in a 25 ml volumetric flask. A 0.5 ml of a 4-aminoantipyrine solution shall be added from a microburette or pipette and the solution diluted to the mark with the 0.03 percent sodium carbonate solution. (A buffered solution (see 4.2.5) maybe used for the dilution. In this case the standard curve would be prepared using the same buffered solution). Add from a microburette or pipette 0.25 ml of the potassium ferricyanide solution. The solution shall be shaken vigorously, allowed to stand 5 minutes, poured into a cuvette and the percent transmission measured within 30 minutes at 505 nanometers with the spectrophotometer which has been adjusted to zero and 100 percent transmission with a blank. The blank shall be prepared in a 25 ml volumetric flask. 0.5 ml of the 4-aminoantipyrine solution shall be added from a microburette or pipette, and the solution diluted to the mark with the 0.03 percent sodium carbonate solution or the buffered solution (whichever was used for the sample). Add from a microburette or pipette 0.25 ml of the potassium ferricyanide solution. The solution shall be shaken vigorously, allowed to stand 5 minutes, poured into a cuvette and the percent transmission adjusted to zero and 100 percent. The blank gives about the same transmission (98-100 percent) as that of distilled water.

5.3 Preparation of standard curve. 0.2 of a g of dihydroxydichlorodiphenyl methane shall be weighed to the nearest ml, dissolved in a few ml of acetone, transferred to a 200 ml volumetric flask, and filled to the mark with acetone. One ml of this solution shall be pipetted into a 100 ml volumetric flask and diluted to the mark with the 0.03 percent sodium carbonate solution. This solution which contains 10 micrograms of dihydroxydichlorodiphenyl methane per ml shall be used for suitable aliquots covering the range of 20 to 60 micrograms. (2 ml equals 20 micrograms, etc.). Each aliquot shall be placed in a 25 ml volumetric flask. The color shall be developed and the percent transmission determined as in 5.2.1. The standard curve shall be plotted on linear graph paper, plotting percent transmission versus micrograms of dihydroxydichlorodiphenyl methane in 25 ml of solution. The standard curve shall be drawn by connecting consecutive points between 20 and 60 micrograms by straight lines.

5.4 Calculations.

5.4.1 Unless otherwise specified, the dihydroxydichlorodiphenyl methane content of the specimen shall be calculated as follows:

$$\text{dihydroxydichlorodiphenyl methane, percent} = \frac{0.02A}{B \times S}$$

Where: A = Dihydroxydichlorodiphenyl methane concentration
from the standard curve in micrograms.
B = Aliquot of 200 ml test solution taken, milliliters.
S = Weight of oven dried specimen, g.

METHOD 2011

6. REPORT

6.1 The dihydroxydichlorodiphenyl methane content of the sample unit shall be the average of the results obtained from the specimens tested and shall be reported to the nearest 0.1 percent.

6.1.1 The individual values for each individual specimen used to calculate the average shall also be reported.

7. NOTES

7.1 Samples of "G-4 Technical" can be obtained from Sindar Corp., a Division of Givaudan Corporation, 125 Delawanna Avenue, Clifton, NJ 07014.

METHOD 2012
July 20, 1978

DIHYDROXYDICHLORODIPHENYL METHANE CONTENT,
PARR CHLORIDE METHOD

1. SCOPE

1.1 This method is intended for determining the dihydroxydichlorodiphenyl methane (2,2' methylene bis-4-chlorophenol) content of cotton and woolen textiles. Although the Parr oxidation method is lengthy, it is well suited to the determination of the inhibitor in textiles following extraction. Errors are a function of the inorganic chloride content of the material being analyzed, becoming considerable when the concentrations of inorganic and organic chlorides approach each other.

2. TEST SPECIMEN

2.1 The test specimen shall be a 20 g composite of the material cut into pieces approximately 1/8 inch (3 mm) square, and thoroughly mixed.

3. NUMBER OF DETERMINATIONS

3.1 Unless otherwise specified in the procurement document, two specimens shall be tested from the composite sample (see 5.1.1).

4. APPARATUS AND REAGENTS

4.1 Apparatus.

4.1.1 Crucible. Small iron crucible with cover, or 22 ml Parr peroxide bomb crucible.

4.1.2 Soxhlet extraction apparatus.

4.1.3 600 ml beaker.

4.1.4 200 ml beaker.

4.1.5 Burettes.

4.1.6 Desiccator.

4.1.7 Blast burner.

4.1.8 Buchner funnel.

FED TEST METHOD STD. NO. 191A

METHOD 2012

4.1.9 Crucible tongs.

4.2 Reagents.

4.2.1 Sodium peroxide, chloride free.

4.2.2 Ferric alum indicator. Saturated solution of ferric ammonium sulfate.

4.2.3 Standard silver nitrate solution, 0.1 N.

4.2.4 Ethyl alcohol, 95 percent.

4.2.5 Standard potassium thiocyanate solution, 0.1 N.

4.2.6 Nitric acid, specific gravity 1.42 to 1.43.

5. PROCEDURE

5.1 Preparation of specimen. Three samples not less than twenty grams each shall be cut from the sample unit. One sample shall be cut from each edge of the sample unit, but will not include the selvage. The third sample shall be taken from the middle of the sample unit. No two samples shall contain the same warp or filling yarns.

5.1.1 The three samples taken from the sample unit shall be cut in small pieces approximately 1/8 inch (3 mm) square and thoroughly mixed to form a composite sample. A 20 g test specimen shall be taken from the composite sample.

5.2 Weight of dry specimen. The material to be tested shall be weighed to the nearest 0.001 g. The specimen shall be placed in the thimble of a Soxhlet extraction apparatus and extracted with ethyl alcohol for eight hours. When extraction is complete, the extract shall be transferred to a tared evaporating dish, evaporated to dryness, cooled in a desiccator, and weighed to a constant weight (± 0.001 g). The residue shall be crushed with a small metal spatula and intimately mixed by kneading.

5.3 Determination of total chlorine. Three-tenths of a g of the residue shall be weighed to the nearest 0.001 g and transferred into the iron crucible or bomb crucible. The weighed residue shall be mixed with 10 g of sodium peroxide. The crucible shall be covered and heated by directing the tip of a narrow flame from a blast burner against any part of the crucible bottom. The heating shall be continued for 1-1/2 minutes after the combustion begins. The crucible shall be shaken holding it with tongs until the melt mixes thoroughly. If a Parr crucible is used, it shall be ignited according to procedures recommended by the manufacturer. The crucible shall be cooled and the crucible and contents

METHOD 2012

introduced into a 600 ml beaker containing 75 ml of distilled water. After the melt has dissolved, the crucible shall be raised to the upper inside edge of the beaker with a stirring rod and the outside of the crucible washed with a stream of distilled water from a wash bottle. The crucible shall be held with the thumb and forefinger on the washed outside surface, and the washings of the inside of the crucible added to the beaker. The beaker contents shall be boiled for 5 minutes, cooled to room temperature, neutralized slowly with pure nitric acid, and, allowed to cool to room temperature. Add from a burette 0.5 ml of the standard potassium thiocyanate solution. If the crucible is nonferrous, alum indicator shall be added. The standard silver nitrate solution shall be added from a burette until the reddish brown color of the thiocyanate disappears, and 2 ml added in excess. The precipitate shall be filtered through a Buchner funnel, washed with cool distilled water, and the filtrate titrated with potassium thiocyanate to a permanent reddish endpoint. A blank determination shall be made using the same amounts of peroxide, acid, and water. The volume of silver nitrate shall be corrected for the blank.

5.4 Determination of inorganic chlorides. The remainder of the residue (see 5.2) shall be weighed to the nearest 0.001 g and transferred to a 200ml beaker. The residue shall be extracted with about 50 ml of hot water, mixing well with a glass rod. The mixture shall be cooled, decanted through filter paper, and the residue washed with warm distilled water. The filtrate shall be diluted to about 300 ml and acidified with 3 ml of colorless nitric acid, and 2 ml of ferric alum indicator added. Add from a burette 0.5 ml of the standard potassium thiocyanate solution. The procedure for the determination of total chlorine (see 5.3) shall be followed beginning with "The standard silver nitrate solution shall be added from a burette until the reddish brown color of the thiocyanate disappears, and 2 ml added in excess."

5.5 Calculations.

5.5.1 The total chlorine content of the test specimen shall be calculated as follows:

$$\text{Total chlorine, Percent} = \frac{3.55F (AB-CD)}{E \times G}$$

Where: A = Volume of silver nitrate solution in ml.

B = Normality of silver nitrate solution.

C = Volume of potassium thiocyanate solution in ml.

D = Normality of potassium thiocyanate solution.

E = Weight of residue used for total chlorine determination in g.

F = Weight of total residue in g.

G = Weight of original specimen in g.

METHOD 2012

5.5.2 The chlorine in the inorganic chlorides in the test specimen shall be calculated as follows:

$$\text{Chlorine in the inorganic chlorides, percent} = \frac{3.55F (HB-ID)}{J X G}$$

Where: H = Volume of silver nitrate solution in ml.

I = Volume of potassium thiocyanate solution in ml.

J = Weight of residue used for inorganic chlorides determination in g.

F, B, D, and G = same as in 5.5.1.

5.5.3 The dihydroxydichlorodiphenyl methane, percent = 3.79 (R-S).

Where: R = Total chlorine, percent (see 5.5.1).

S = Chlorine from inorganic chlorides, percent (see 5.5.2).

6. REPORT

6.1 The dihydroxydichlorodiphenyl methane content of the sample unit shall be the average of the results obtained from the specimens tested and shall be reported to the nearest 0.1 percent.

6.1.1 The individual values for each individual specimen used to calculate the average shall also be reported.

FLUORINE CONTENT OF TEXTILE MATERIALS

1. SCOPE

1.1 This method is intended for determining the fluorine content of materials which have fluorine compounds for moth repellency.

2. TEST SPECIMEN

2.1 The test specimen shall be 0.5 ± 0.05 g composite of the material cut into pieces approximately 1/8 inch (3 mm) square, and thoroughly mixed.

3. NUMBER OF DETERMINATIONS

3.1 Unless otherwise specified in the procurement document, two specimens shall be tested from each sample unit.

4. APPARATUS AND REAGENTS

4.1 Apparatus.

4.1.1 Fluorine determination apparatus. Fluorine determination apparatus having a 300 ml flask with a no. 40/50 joint (see 7.1).

4.1.2 Burette.

4.1.3 Beakers.

4.1.4 200 ml volumetric flask.

4.1.5 Bunsen burner or electric heater.

4.2 Reagents.

4.2.1 Sulfuric acid. 50 percent sulfuric acid (H_2SO_4) by volume in distilled water.

4.2.2 Thorium nitrate. 0.01N thorium nitrate $Th(NO_3)_4$ standardized against a standard sodium fluoride (NaF) solution.

4.2.3 Hydrochloric acid. 0.1N hydrochloric acid (HCl) solution.

4.2.4 Sodium hydroxide. 10 percent sodium hydroxide (NaOH) solution.

METHOD 2013

4.2.5 Indicator. 0.05 percent aqueous solution sodium alizarin sulfonate.

5. PROCEDURE

5.1 Preparation of specimen. Three samples not less than two g each shall be cut from the sample unit. One specimen shall be cut from each edge of the sample unit but will not include the selvage. The third sample shall be taken from the middle of the sample unit. No two samples shall contain the same warp or filling yarns.

5.1.1 The three samples taken from the sample unit shall be cut in small pieces approximately 1/8 inch (3 mm) square and thoroughly mixed to form a composite sample. A 0.5 g test specimen shall be taken from the composite sample.

5.2 Transfer specimen to the 300 ml flask of the fluorine apparatus (see figure 2013) and add 40 ml of 50 percent sulfuric acid. Connect the flask to the fluorine apparatus. Immerse the lower end of condenser in 20 ml of distilled water in the receiving beaker to insure the solution of gases.

5.3 Heat gradually to dissolve specimen and then start distillations with a high heat (Bunsen burner or electric heater). Avoid localized overheating when using Bunsen burner by protecting the flask with asbestos sheeting placed directly under the bottom of the flask.

5.4 Maintain liquor temperature between 277° and 284°F (136° and 140°C) by dropping distilled water from a separator funnel inserted in the neck of the flask. Collect 200 ml but not less than 176 ml of distillate. Collect 185 ± 5 ml of distillate. Transfer the distillate to 200 ml volumetric flask, and fill to the mark with distilled water. Remove any of the fats or waxes that are present and again make up volume with distilled water.

5.5 Titrate two 20 ml aliquots of the distillate. To each aliquot add two drops sodium alizarin sulfonate indicator and one drop of 10 percent sodium hydroxide. The addition of the sodium hydroxide will produce a light violet color (see 7.2, 7.3). Titrate the distillate with 0.1N hydrochloric acid to a yellow coloration then add five drops in excess (see 7.4). Titrate the resultant solution to a faint but definite pink coloration with 0.01N thorium nitrate solution.

5.6 In cases where an alternate calculation formula is necessary because the weight is more or less than 0.5 g the percent fluorine (F) shall be calculated as follows:

$$\text{Percent fluorine} = \frac{\text{ml of Th(NO}_3)_4 \times \text{N of Th(NO}_3)_4 \times 0.19 \times 100}{\text{Sample weight (g)}}$$

6. REPORT

6.1 The percent fluorine shall be the average of specimens tested from a sample unit and shall be reported to the nearest 0.1 percent.

6.2 Individual results used to calculate the average shall also be reported.

7. NOTES

7.1 The apparatus for fluorine determination used in this method may be purchased from Ace Glass Inc., Vineland, NJ 08360 as No. 6430.

7.2 Twenty ml aliquot of distillate should never require more than one drop of 10 percent sodium hydroxide solution. When more is required, contamination of the distillate is indicated. The distillate shall be discarded and a new specimen tested.

7.3 Sodium ion concentration in the distillate should be kept to a minimum since these ions cause erroneous (high) results.

7.4 The pH of the solution taken for titration is important. The pH provided by the addition of five drops excess 0.1N HCl is ideal (i.e. 3.2). The use of buffers is not recommended because the end point is not well defined even in the absence of a buffer.

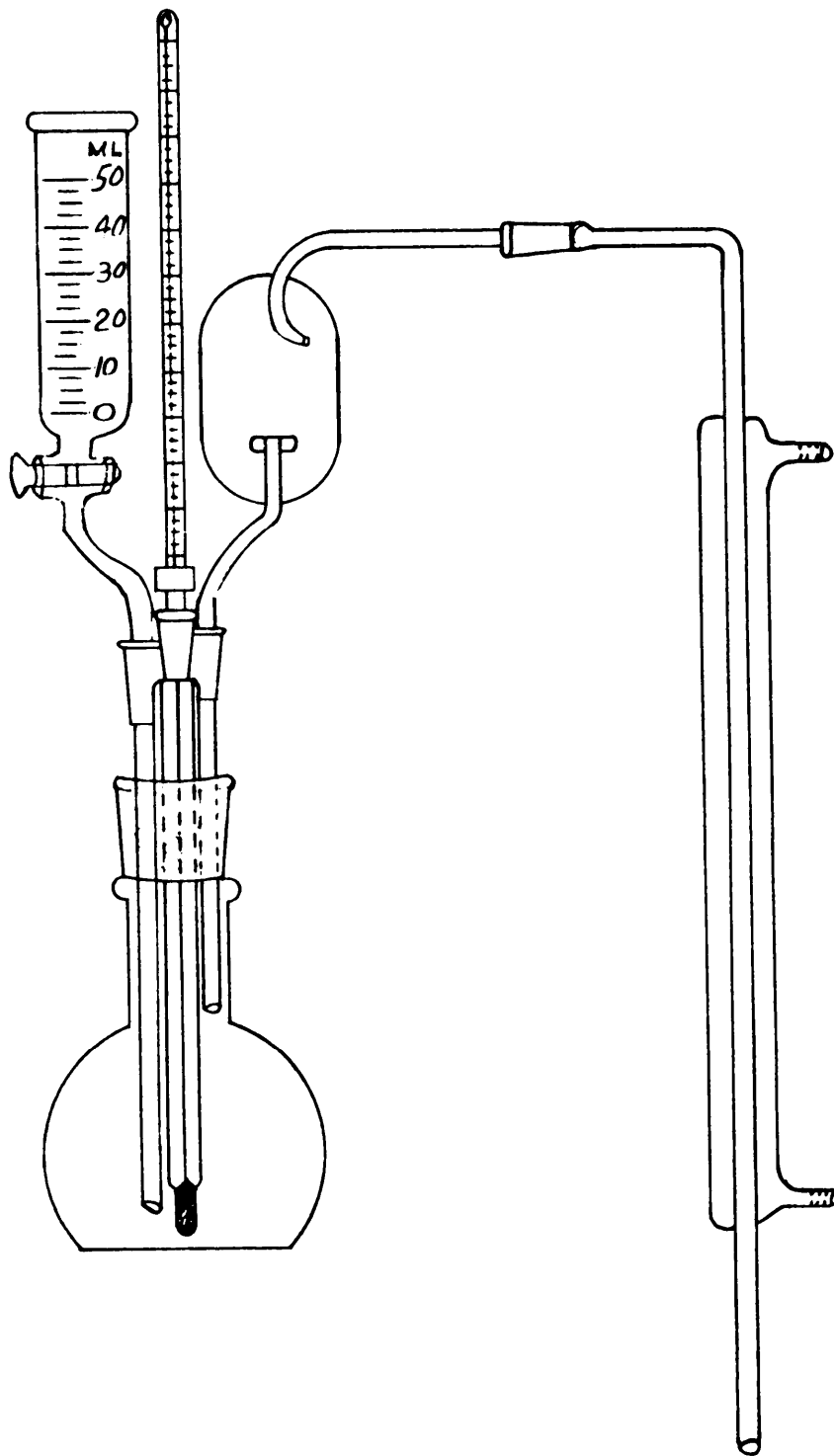

FIGURE 2013 - Test apparatus for fluorine content of textile materials.

METHOD 2015
July 20, 1978

SODIUM SALT OF 5-CHLORO-2- [4CHLORO-2- [3-(3,4 DICHLOROPHENYL)-
UREIDO] -PHENOXY] BENZENSULFONATE CONTENT

1. SCOPE

1.1 This method is intended for determining the sodium-5-chloro-2- [4 chloro-2- [3-(3,4 dichlorophenyl)-ureido] -phenoxy] benzenesulfonate content of woolen textile materials that have been treated with this compound as a mothproofing agent (see 7.1 and 7.2).

2. TEST SPECIMEN

2.1 All wool. When the material to be tested is 100 percent wool, the specimen shall be 500 ± 50 mg.

2.2 Polyester and wool blend. When the material to be tested is a blend of polyester and wool, the specimen shall be 1000 ± 100 mg.

3. NUMBER OF DETERMINATIONS

3.1 Unless otherwise specified in the procurement document, two specimens shall be tested from each sample unit.

4. APPARATUS AND REAGENTS

4.1 Apparatus.

4.1.1 Electric heater with variable control.

4.1.2 Heat-resistant glass flask. A 250 ml, round bottom, single neck, alkali resistant, heat-resistant glass flask.

4.1.3 250 ml trap bulb and connecting arm (see 7.3).

4.1.4 Graham condenser (jacket 300 mm long).

4.1.5 Funnel.

4.1.6 500 ml volumetric flasks.

4.1.7 1000 ml volumetric flasks.

4.1.8 Pipettes.

FED. TEST METHOD STD. NO. 191A

METHOD 2015

4.1.9 Boiling chips.

4.1.10 Spectrophotometer or filter photometer. Spectrophotometer or filter photometer with a green filter having a maximum transmission at approximately 500 nanometers.

4.1.11 Silicone stopcock lubricant.

4.1.12 Potassium Iodide-Starch test paper.

4.1.13 Congo Red test paper.

4.1.14 Red and blue litmus paper.

4.1.15 Analytical balance.

4.1.16 Air oven.

4.1.17 Soxhlet extractor.

4.2 Reagents.

4.2.1 2.0 N potassium hydroxide (KOH), 112 g of potassium hydroxide pellets ACS, per 1000 ml of solution.

4.2.2 1.0 N hydrochloric acid (HCl), 85 ml of hydrochloric acid, 37.5 percent concentrated, ACS per 1000 ml of solution.

4.2.3 37.5 percent concentrated hydrochloric acid, ACS.

4.2.4 0.1 N sodium nitrite (NaNO_2), 6.9 g sodium nitrite ACS, Per 1000 ml of solution. Sodium nitrite is subject to decomposition and should be made up fresh.

4.2.5 0.01 molar benzoyl-H-acid (monosodium salt of 1-naphthol-3,6-disulfonic acid, 8-benzamido), 8.9 g 50 percent benzoyl-H-acid per 1000 ml of solution. Store protected from light, (see 7.3).

4.2.6 1.0 N sodium bicarbonate (NaHCO_3), 42 g sodium bicarbonate ACS, per 1000 ml solution.

4.2.7 3,4 dichloroaniline (distilled and pure, melting point $71^\circ\text{-}72^\circ\text{C}$), (see 7.3).

4.2.8 Antifoam agent (polysiloxane derivative) (see 7.4).

4.2.9 Chloroform, ACS.

4.2.10 Distilled water.

5. PROCEDURE

5.1 Preparation of standard reference solution.

5.1.1 Dichloroaniline-hydrochloride stock solution. On an analytical balance, weigh 162.0 ± 0.1 mg of 3,4 dichloroaniline. Place in a 1000 ml volumetric flask. Add 10 ml of 37.5 percent concentrated hydrochloric acid and 10 ml of distilled water. Heat the flask in a water bath with boiling water and keep shaking the flask until the dichloroaniline is completely dissolved. Dilute to volume with distilled water 65° to 81°F (18° to 27°C).

5.1.2 Standard reference solution. Pipette 20 ml of dichloroaniline-hydrochloride stock solution (5.1.1) into a 1000 ml volumetric flask. Add 30 ml. of distilled water 45° to 50°F (7° to 10°C). Cool the solution to 45° to 50°F (7° to 10°C), add 8 ml 1.0 N hydrochloric acid and 2 to 3 ml of 0.1 N sodium nitrite. Test with Congo Red test paper and the paper should turn dark blue instantly. Also test with Potassium Iodide-Starch test paper and the paper should turn black instantly. Agitate the solution thoroughly and keep at 45° to 50°F (7° to 10°C) for exactly 20 minutes out of direct light. Add 30 ml of 0.1 N sodium bicarbonate solution to effect neutrality while maintaining the cold temperature. Check for neutrality with both red and blue litmus paper. Immediately add 3 ml of 0.01 M benzoyl-H-acid and agitate for two minutes to effect good coupling. Dilute to volume with distilled water. Determine absorbance of this standard reference solution using a filter photometer or spectrophotometer. Maximum absorbance occurs at approximately 505 nanometers. When using a filter photometer, a green filter having a maximum transmission at approximately 500 nanometers should be used.

5.2 Weight of dry specimen. The specimen shall be placed in a weighing bottle, dried in a circulating air oven at a temperature of 221° to 230°F (105° to 110°C), cooled in a desiccator, and weighed. Repeat this cycle until a weight is obtained that is constant to ± 0.001 g. This is the "Weight of the dry specimen" and in the calculation of results is indicated as "O".

5.3 Testing of specimens containing 100 percent wool.

5.3.1 Cut specimen into small pieces and place in a 250 ml round bottom distillation flask with a few boiling chips. Add 130 ml of 2.0 N potassium hydroxide and the antifoam agent. Grease all ground glass connecting joints of distilling apparatus with silicone grease. Assemble the complete distilling apparatus as shown in Figure 2015 so that the distillate is collected through a funnel into a 500 ml volumetric flask. Heat the distilling flask gently, using an electric heater with variable control, until the liquid boils and boil

METHOD 2015

gently for 10 minutes. Increase the heating until vapor passes through 250 ml trap bulb and connecting arm and into the condenser. Continue distillation until a minimum of 100 ml of distillate has been collected. The distillate must not be contaminated by any carry-over of the liquid being distilled. Cool distillate to 45° to 50°F (7° to 10°C). Add 8 ml of 1.0 N hydrochloric acid and 2-3 ml of 0.1 N sodium nitrite. Agitate and test with Congo Red test paper; paper turns dark blue instantly. Test with Potassium Iodide-Starch test paper; paper turns black instantly. Agitate solution thoroughly and keep at 45° to 50°F (7° to 10°C) for 20 minutes while protecting from direct light. Add 30 ml of 1.0 N sodium bicarbonate solution and check solution for neutrality with red and blue litmus paper. Add 3 ml of 0.01 M benzoyl-H-acid and agitate 2 minutes to effect good coupling. Dilute to volume with distilled water and measure the absorbance using a filter photometer or spectrophotometer. Maximum absorbance occurs at approximately 505 nanometers. When using a filter photometer, a green filter having a maximum transmission at approximately 500 nanometers should be used.

5.4 Testing specimens of polyester/wool blend.

5.4.1 The specimen shall be extracted with chloroform for ten (10) cycles in a Soxhlet extractor. Dry the specimen and continue with the procedure described in 5.3.1.

5.5 Calculations.

5.5.1 Specimens containing 100 percent wool. The percent mothproofing agent on the wool fiber shall be calculated from the absorbance measurements as follows:

$$\text{Percent Mothproofing Agent} = \frac{544 \times A_t}{A_s \times O \times P}$$

Where: A_s = Absorbance of standard reference solution (see 5.5.3).

A_t = Absorbance of test solution.

O = Original dry weight of specimen in mg (5.2).

P = Proportion of wool in the sample, expressed as a decimal to the nearest 0.01.

5.5.2 Specimens containing polyester/wool blend. The percent mothproofing agent on the wool fiber shall be calculated from absorbance measurements as follows:

$$\text{Percent Mothproofing Agent} = \frac{544 \times A_s \times 1.09}{A_t \times O \times P}$$

Where: A_s = Absorbance of standard reference solution (see 5.5.3).
 A_t = Absorbance of test solution.
 O = Original dry weight of specimen in mg (5.2).
 P = Proportion of wool in the sample, expressed as a decimal to the nearest 0.01.

5.5.3 Where spectrometric measurements are taken from a transmission scale the absorbance shall be calculated as follows:

$$A = \text{Log}_{10} 1/T.$$

Where: T = transmission measurement.
 A = absorbance.

6. REPORT

6.1 The percent mothproofing agent content of a sample unit shall be reported as the average of the values obtained for the specimens tested and shall be reported to the nearest 0.1 percent.

6.1.1 The individual values for each individual specimen used to calculate the average shall be reported to the nearest 0.01 percent.

7. NOTES

7.1 This method determines the content as a 100 percent active (pure) material.

7.2 This mothproofing formulation may be obtained under the trade name of Mitin FF High Cone. from Ciba-Geigy Corp., Dyestuffs and Chemicals Division, Swing Road, Greensboro, NC 27409 or under the name of Intracide M from Dyes and Chemicals Division, Crompton and Knowles Corp., Route 208, Fair Lawn, NJ 07410.

7.3 Materials required for testing. The 3,4 dichloroaniline, the benzoyl-H-acid, and the 250 ml trap bulb and connecting arm may be obtained from CIBA-GEIGY Corporation, Dyestuffs and Chemical Division, Swing Road, Greensboro, NC 27409.

7.4 Antiform A from Dow Corning Corporation was found to be suitable for use in this test method.

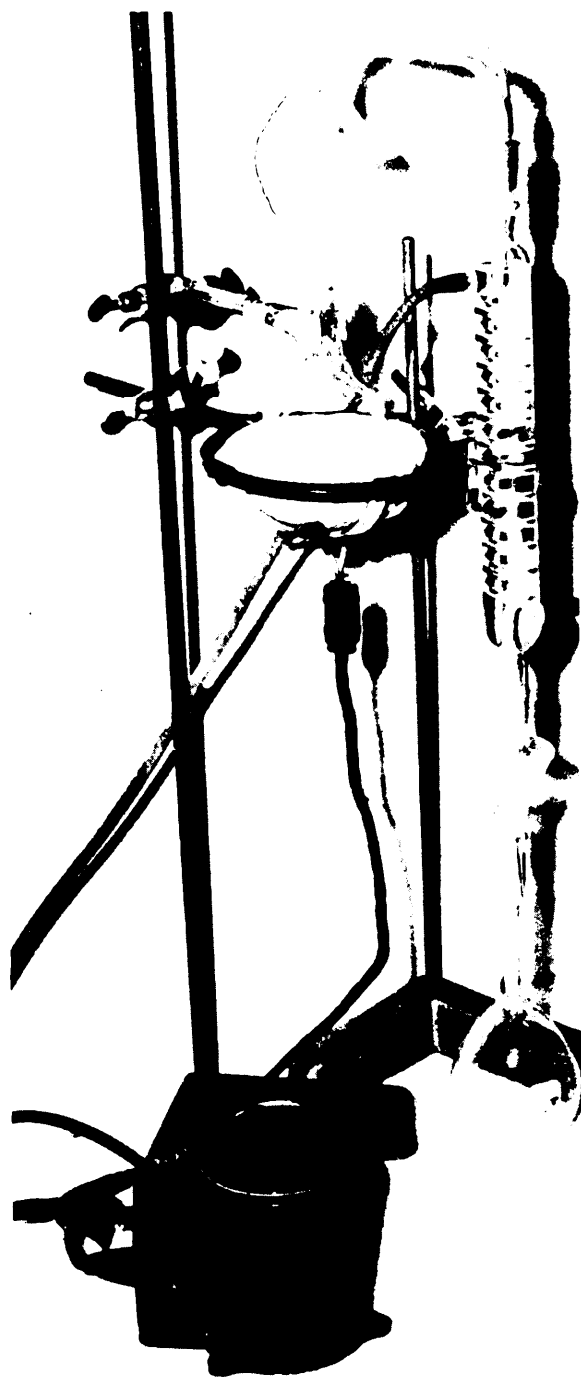

FIG 2015 DISTILLING APPARATUS

SODIUM SALT OF [(4, 5-DICHLORO, 2-CHLOROMETHANE
SULFONAMIDO) 3', 4', 6', TRICHLORO] DIPHENYL ETHER CONTENT

1. SCOPE

1.1 This method is intended for determining the sodium- [(4, 5-dichloro, 2-chloromethane sulfonamide) 3', 4', 6', trichloro] diphenyl ether (see 7.4) content of woolen textile materials that have been treated with this compound as a moth-proofing agent (see 7.1 and 7.2).

2. TEST SPECIMEN

2.1 All wool. When the material to be tested is 100 percent wool, the specimen shall weigh 1.000 ± 0.100 g.

2.2 Polyester and wool blend. When the material to be tested is a blend of polyester and wool, the specimen shall weigh 2.000 ± 0.200 g.

3. NUMBER OF DETERMINATIONS

3.1 Unless otherwise specified in the procurement document, two specimens shall be tested from each sample unit.

4. APPARATUS AND REAGENTS

4.1 Apparatus.

4.1.1 Bunsen burner with adjustable gas flow.

4.1.2 Heat-resistant glass flask. A 250 ml, round bottom, single neck, alkali resistant, heat-resistant glass flask.

4.1.3 Connecting arm with 50 ml dropping funnel (see 7.3.1).

4.1.4 Graham condenser. A Graham condenser with a jacket 300 mm long.

4.1.5 Spiral spring, stainless steel (see 7.3.1).

4.1.6 Water bath. A water bath of suitable size to accommodate a 250 ml round bottom flask.

METHOD 2016

4.1.7 250 ml volumetric flasks.

4.1.8 Pipettes.

4.1.9 Boiling chips or glass beads.

4.1.10 Spectrophotometer or filter photometer. Spectrophotometer or filter photometer with a filter having a maximum transmission at approximately 490 nanometers.

4.1.11 Silicone stopcork lubricant.

4.1.12 pH paper.

4.1.13 Analytical balance.

4.1.14 Laboratory drying oven.

4.2 Reagents.

4.2.1 Sodium hydroxide solution. A 20 percent sodium hydroxide solution (NaOH), [200 grams of ACS grade sodium hydroxide pellets per 1000 ml of solution].

4.2.2 Hydrochloric acid. A 15 percent hydrochloric acid (HCL), [400 ml of ACS grade cone. hydrochloric acid (37.5 percent HCL) per 1000 ml of solution].

4.2.3 Methanol. (CH₃OH) ACS grade.

4.2.4 2-propanol. (CH₃CHOHCH₃) ACS grade.

4.2.5 Sodium nitrite solution. A one percent sodium nitrite solution (NaNO₂), [10 grams of ACS grade sodium nitrite per 1000 ml of solution]. Sodium nitrite is subject to decomposition and should be made up fresh.

4.2.6 350.0 mg/liter solution of sodium [(4, 5-dichloro, 2-chloromethane sulfonamido) 3', 4', 6' trichloro] diphenyl ether (DCSTD) in methanol. This solution represents the standard (see 7.3.1).

4.2.7 one percent ethylchromotropic acid (1-hydroxy, 8-ethoxy naphthalene, 3, 6 disulfonic acid), [1.0 gram of ethylchromotropic acid in 100 ml of distilled water]. Ethylchromotropic acid is subject to decomposition and should be made up fresh daily. Store protected from light (see 7.3.1).

4.2.8 Distilled water.

5. PROCEDURE

5.1 Preparation of standard solution. Pipette 10.0 ml of the standard solution of DCSTD prepared as described in 4.2.6 into a 250 ml round bottom, single neck flask. Add 15 ml methanol, 40 ml of 20 percent sodium hydroxide and glass beads or boiling chips. Mix by swirling. Attach the connecting arm with the dropping funnel and condenser after lubricating the connecting ground joints with silicone grease (see figure 2016). Heat flask with a gas flame. Distill over into a 250 ml volumetric flask containing 6 ml of 15 percent hydrochloric acid, until about 20 ml are left in the flask. Without interrupting the heating, allow 50 ml of distilled water to drop from the dropping funnel during 10 minutes in such a manner that the level of the liquid in the round bottom flask will not be raised. The end point of the distillation is reached when the steam bubbles that are visible in the flask have become small and creamy (2 to 5 ml diameter). The gas burner is turned off and additional 30 ml of distilled water are introduced dropwise (0.5 ml/s) into the flask from the dropping funnel during 1 minute. This will cause a short, violent boiling of the solution. The dropping funnel is disconnected and the condenser is rinsed with 10 ml 2-propanol and then with 5 ml of distilled water. Both rinsing fluids are allowed to flow into the volumetric flask. Cool the solution in the flask to a temperature within 0° to 9°F (0° to 5°C) (see 7.3.2). Add 2.0 ml of a chilled 1 percent sodium nitrite solution while mixing by gentle swirling action. Diazotization is allowed to proceed in subdued light for exactly 3 minutes while mixing is continued. 1.5 ml of 1 percent ethylchromotropic acid is added and the solution is again mixed by swirling action. While adding 8 ml of 20 percent sodium hydroxide and mixing, the solution turns red. It is filled to volume with distilled water and the absorbance of the solution at 490 nm is determined on a spectrophotometer within 30 minutes of preparation.

5.2 Weight of dry specimen. The specimen shall be placed in a weighing bottle, dried in a circulating air oven at a temperature of 221° to 230°F (105° to 110°C), cooled in a desiccator, and weighed. Repeat this cycle until a weight is obtained that is constant to ± 0.001 g. This is the "Weight of the dry specimen" and in the calculation is indicated as "W".

5.3 Testing of specimens fabricated from 100 percent wool. Place the specimen into the spiral spring and place it into a 250 ml round bottom flask (see figure 2016). Add 20-ml methanol and glass beads or boiling chips. Attach a reflux condenser and extract the active ingredient by refluxing on a water bath for 20 minutes. The spiral spring should be placed in such a manner that the condensed methanol is dripping on the test specimen during the extraction process. After extraction, lift the spiral spring and rinse by pouring 2 times 5 ml methanol over the test specimen. Remove the spiral spring with the test sample. Add 40 ml of 20 percent sodium hydroxide solution to the extract. Mix by swirling and continue with distillation, diazotization and development as specified in 5.1.

METHOD 2016

5.4 Testing of specimens fabricated from polyester/wool blends. The specimen is treated in the same manner as described in 5.3.

5.5 Calculations.

5.5.1 Specimens fabricated from 100 percent wool. The percent moth-proofing compound on the wool fiber shall be calculated from the absorbance value as follows:

$$\text{Percent moth-proofing compound} = \frac{0.35 \times AT}{AS \times W}$$

Where:

AS = the absorbance of the standard reference solution (see 5.5.3).

AT = the absorbance of the test solution.

W = the original dry weight of specimen in grams (see 5.2).

5.5.2 Specimens fabricated from polyester/wool blends. The percent moth-proofing compound on the wool shall be calculated from absorbance values as follows :

$$\text{Percent moth-proofing compound} = \frac{0.35 \times AT}{AS \times W \times P}$$

Where:

AS = the absorbance of the standard reference solution (see 5.3).

AT = the absorbance of the test solution.

W = the original dry weight of the specimen in grams (see 5.2).

P = the proportion of wool in the sample, expressed to the nearest 0.5 percent.

5.5.3 Where spectrophotometric transmittance measurements are taken, the absorbance shall be calculated as follows:

$$A = \text{Log}_{10} \left(\frac{1}{T} \right)$$

Where:

A = Absorbance.

T = Transmittance.

6. REPORT

6.1 The percent moth-proofing compound content of a sample unit shall be reported as the average of the values obtained for the specimens tested and shall be Mreposted to the nearest 0.1 percent.

6.1.1 The individual values for each individual specimen used to calculate the average shall be reported to the nearest 0.01 percent.

7. NOTES

7.1 This method determines the content as a 100 percent active (pure) material.

7.2 This moth-proofing formulation may be obtained under the trade name of Edolan U Highly Cone. from the Verona Dyestuff Division of Mobay Chemical Corporation, Union, NJ 07083.

7.3 Materials and reagents required for testing.

7.3.1 Materials required for testing, extracting and distillation glass apparatus and stainless steel spiral spring; reagent of DCSTD compound, and ethylchromotropic acid used for the alternating moth-proofing compound may be obtained from Verona Dyestuff Division of Mobay Chemical Corp., Union, NJ 07083.

7.3.2 A salt-ice mixture is useful for this purpose (see 5.1).

7.4 Suggested chemical name. Another chemical name for this moth-proofing compound registered by the Environmental Protection Agency is as follows:

Sodium salt of 1, 4', 5' -trichloro-2'-(2, 4, 5-thrichlorophenoxy)
methane sulfonanilide (see 1.1)

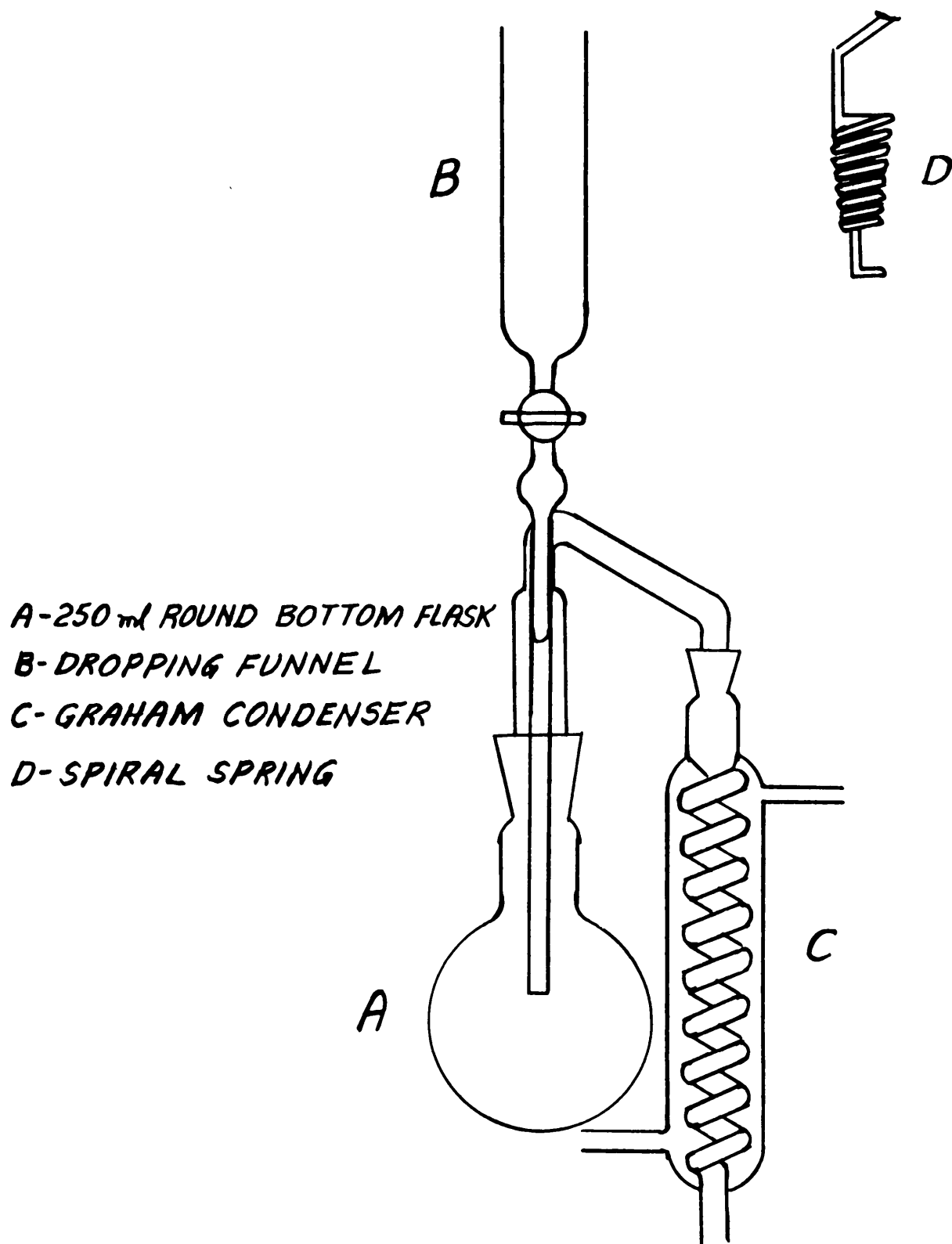

FIGURE 2016- EXTRACTION APPARATUS

METHOD 2020
July 20, 1978

PRESENCE OF LABILE SULFUR IN TEXTILE MATERIALS

1. SCOPE

1.1 This method is intended for determining the presence of labile sulfur in dyed cellulosic textiles and its propensity for producing acid damage through oxidative degradation of dyes and sulfur-bearing compounds present on the material. It may also be used to determine the effect of sulfur inherent in the fiber, as in the case of viscose rayon. It is also applicable to functionally finished materials.

1.2 This method may also be applied indirectly in the determination of labile sulfur on fibers which contain sulfur in their chemical structure.

2. TEST SPECIMEN

2.1 Cloth. The test specimen shall be 9 inches (229 mm) full width of the material to be tested.

2.2 Narrow cloths, tapes, webbings, and braid. The test specimen shall be approximately 20 yards (18 m) full width of the material to be tested.

2.3 Threads and light cordage. The test specimen shall be approximately 200 yards (183 m) of the material to be tested.

3. NUMBER OF DETERMINATIONS

3.1 Unless otherwise specified in the procurement document, two specimens shall be tested from each sample unit.

4. APPARATUS, REAGENTS AND METHOD CITED

4.1 Apparatus.

4.1.1 Analytical balance. Analytical balance capable of weighing to an accuracy of at least 0.001 g.

4.1.2 Circulating air oven. Circulating air oven thermostatically controlled, capable of maintaining the required temperature within $\pm 2^{\circ}\text{F}$ ($\pm 1^{\circ}\text{C}$).

METHOD 2020

4.1.3 One-pint jar. One pint spring-sealed Mason Jar or equivalent, fitted with a plastic sulfur-free gasket.

4.1.4 Turbidimeter (see 7.1 and 7.2).

4.1.5 Filter paper.

4.1.6 Cotton lawn cloth. Bleached, unstarched, desized 96 by 100 combed yam cotton lawn cloth, weighing 4 yards to the pound (3.66 m per 453.6 g). No blueing or optical brightener shall be used on the cloth.

4.1.7 Water bath - temperature controlled.

4.2 Reagents.

4.2.1 Distilled water.

4.2.2 Lead acetate solution. Five percent lead acetate solution prepared by adding 5 g of lead acetate CP reagent grade to distilled water and making up to 100 ml. If the solution is not clear, add a few drops of glacial acetic acid.

4.2.3 Acid stannous chloride solution. Acid stannous chloride solution prepared by dissolving 100 g of stannous chloride crystals ACS in 100 ml of hydrochloric acid ACS (35 percent concentration) and adding 50 ml of distilled water.

4.2.4 Sodium Chloride CP.

4.2.5 Caustic solution. Ten percent caustic solution prepared by dissolving 10 g of sodium hydroxide CP in distilled water and making up to 100 ml.

4.2.6 Sodium carbonate solution. Sodium carbonate solution prepared by dissolving 10 g of sodium carbonate CP anhydrous in distilled water and making up to 100 ml in a volumetric flask.

4.2.7 Sodium sulfide chips U.S.P. or crystals ACS.

4.2.8 Barium chloride solution. Barium chloride solution prepared by dissolving 2 g barium chloride ACS in distilled water and diluting to 100 ml in a volumetric flask.

4.2.9 Concentrated nitric acid CP.

4.2.10 Sulfuric acid (0.001N). 0.001N sulfuric acid prepared by diluting 10 ml of 0.1N sulfuric acid and making up to 1000 ml with distilled water. The 0.1N sulfuric acid is made by diluting 5.10 g of sulfuric acid concentrated (96 percent) to 1000 ml.

METHOD 2020

4.2.11 Buffer solution. Buffer solution, pH 7.5, prepared by adding 75 ml of 0.1 molar citric acid CP solution to 925 ml of 0.2 molar disodium acid phosphate CP solution.

4.2.12 Sodium perborate solution. Sodium perborate solution prepared by dissolving 2.5 g of sodium perborate in distilled water and diluting to 100 ml..

4.3 Method cited.

4.3.1 Method 2811, pH of Textiles, Electrometric.

5. PROCEDURE

5.1 Unless otherwise specified in the procurement document, the specimens tested shall be conditioned under standard conditions in accordance with Section 4 of this Standard.

5.2 Unless otherwise specified in the procurement document, the procedure for cellulosic textiles shall be followed. When specified, the procedure for textiles containing sulfur in their structure shall be followed.

5.3 Standard sample. When a standard sample has been established and is to be utilized for comparative testing purposes, a specimen of the standard sample shall be tested at the same time and under the same conditions as the specimen undergoing test.

5.4 No standard sample. When no standard sample in the specific shade has been established, the specimen shall be compared with a vat-dyed cotton cloth comparable in depth of shade or thread, cord, yarn or narrow cloth for determination of comparative loss in strength, tested at the same time and under the same conditions as the specimen undergoing test.

5.5 Cellulosic textiles.

5.5.1 Determination of presence of sulfur with lead acetate. 1.50 ± 0.01 g of the material to be tested shall be cut into small pieces or shredded and placed in a test tube. The material shall be covered with stannous chloride solution. A filter paper wet out in lead acetate solution shall be placed over the mouth of the test tube. The test tube shall then be heated over a low flame until the solution is boiling. The solution should not be boiled for more than 15 seconds. A brown to black stain appearing on the paper indicates the presence of sulfur. If a negative test is obtained by the lead acetate determination, the test shall be terminated.

METHOD 2020

5.5.2 pH determination. If a positive test is obtained by the lead acetate determination, the pH of the original material shall be determined in accordance with Method 2811 and the value recorded.

5.5.3 Adjustment of pH. If a positive test is obtained by the lead acetate determination, six specimens 6 inches by 8 inches (152 by 203 mm) with the long dimension in the warp direction for cloths, or ten full width specimens 14 inches (356 mm) in length for tapes, webbing, threads, and light cordage shall be taken. Three specimens for cloths or five specimens for narrow materials shall then be Immersed In a buffer solution at pH 7.5 for 1 hour at a temperature of $77^{\circ} \pm 4^{\circ}\text{F}$ ($25^{\circ} \pm 2^{\circ}\text{C}$). The specimens shall then be rinsed in distilled water and dried at a temperature not exceeding 160°F (71°C).

5.5.4 Aging. The dried specimens adjusted for pH shall be placed on a stainless steel wire mesh platform in a Mason Jar or equivalent, capable of being spring-sealed, to reduce the rate of evaporation of moisture. A sulfur-free plastic gasket shall be used, and the spring shall engage the cover lightly but shall not be sealed in place. Twenty percent by weight of distilled water on the weight of the fiber shall be added to the jar without wetting the specimens, and, after sealing, the jar shall be placed in a circulating air oven at $211^{\circ} \pm 2^{\circ}\text{F}$ ($99^{\circ} \pm 1^{\circ}\text{C}$) for 24 hours.

5.5.5 Breaking strength determination. The aged specimen shall be taken from the jar and allowed to reach moisture equilibrium under standard textile conditions. The solution shall be kept sealed and retained for use in 5.5.7. The unaged specimens from 5.5.3 shall also be conditioned. Specimens shall then be tested under standard textile conditions for breaking strength in accordance with the method cited in the material specification or procurement document. Breaking strength of the aged specimen shall be reported as percent change from the breaking strength of the unaged specimens. A decided lowering in breaking strength will occur if labile sulfur is present (see 5.7) .

5.5.6 Change in pH. The aged specimens from the breaking strength test shall be tested for pH in accordance with Method 2811 and the value recorded. A drop in pH from the value obtained in 5.5.2 will occur if labile sulfur is present (see 5.7).

5.5.6.1 If a drop in pH is not recorded, the absence of labile sulfur shall be recorded and the test shall be terminated.

5.5.7 Turbidity of the water extract. A 50 ml aliquot of the water extracted from the pH test (see 5.5.6) shall be added to 10 ml of 20 percent barium chloride solution and 1 ml of concentrated nitric acid. The solution shall be placed in a turbidimeter cell. The maximum level of turbidity shall be determined. (It should be cautioned that the total turbidity level may fall after reaching a maximum due to crystal growth). The value shall be recorded at a point which represents the maximum level of turbidity. To qualify the results, a series of standards containing 5, 25, 50, 75, 125, and 150 ml of 0.001N sulfuric acid solution and 2 ml of nitric acid shall be made up to 250 ml. Fifty ml aliquots of these various standards shall be treated with barium chloride in exactly the same manner as the extract from the aged specimens. The quantities of barium sulfate formed by the various standards represent a slight trace, trace, medium, medium heavy, heavy, and very heavy concentrations of labile sulfur in the specimens. The adjective rating so applied shall be based on the turbidity of the specimen solution which comes closest to the appropriate standard. That is, if the turbidity of the test solution were slightly less or slightly more than that of the standard containing 25 ml of the 0.001N sulfuric acid, it would be recorded as containing a "trace".

5.6 Textiles containing sulfur in their structure.

5.6.1 When labile sulfur compounds, such as sulfur dyes, are suspected on fibers containing sulfur in their structure, as wool, 1.5 ± 0.1 g of the specimen shall be placed in a test tube, and 3 to 5 ml of water, 2 ml of 10 percent sodium carbonate solution, and 400 mg of sodium sulfide chips shall be added. The contents of the test tube shall be raised to a boil and boiled for 2 minutes. The solution shall then be transferred to a second test tube. A 1.5 ± 0.1 g sample of the cotton lawn cloth shall be placed in the solution, 20 mg of sodium chloride added, and the contents raised to a boil and boiled for 2 minutes. The cotton lawn cloth shall be removed from the test tube, rinsed lightly in distilled water, and oxidized by exposure to air or in a solution containing 2.5 g of sodium perborate in 100 ml of water. The cloth shall then be thoroughly rinsed in water and dried.

5.6.2 Determination of presence of sulfur with lead acetate. The cotton lawn cloth shall be tested for the presence of sulfur as specified in 5.5.1.

5.6.3 Transference of sulfur to cotton lawn cloth. If a negative test is obtained by the lead acetate determination, the test shall be terminated. If a positive-test is obtained by the lead acetate determination, a 1.5 ± 0.5 g sample of the material undergoing test and a 1.5 ± 0.5 g sample of cotton lawn cloth shall be used and the sulfur dye of compound transferred following the procedure of 5.6.1.

METHOD 2020

5.6.4 Determination of pH and turbidity of the modified lawn cloth after aging. Specimens of the lawn cloth containing the transferred dye or compound shall be buffered in accordance with 5.5.3 and then aged in accordance with 5.5.4. The specimens shall then be dried and the pH determined in accordance with Method 2811. The sulfate ion concentration of the water solution after specimen aging shall be determined as specified in 5.5.7.

5.7 Evaluation.

5.7.1 The formation of a tan to black stain in the lead acetate test shall indicate the presence of sulfur dyes or compounds. A drop in pH to a more acid condition, followed by a loss in breaking strength on aging, or the demonstration of the formation of sulfate ion in the barium sulfate test, or both shall be considered as definite evidence of the presence of labile sulfur that may cause damage by oxidation in storage.

5.7.2 Standard sample.

5.7.2.1 When a standard or comparison sample has been established, the test specimen and the standard or comparison sample shall be compared and rated as follows:

Pass. Equal to or lighter than the standard sample in degree of staining by the lead acetate test. Equal to or less than the standard sample in breaking strength loss after aging. Equal to or less than the standard sample in amount of sulfate ion produced.

Fail. Degree of staining by the lead acetate test greater than that of the standard sample. Breaking strength loss after aging greater than the standard sample. Amount of sulfate ion produced greater than the standard sample.

5.7.3 No standard sample.

5.7.3.1 Unless otherwise specified in the procurement document, when no standard or comparison sample has been established, the test specimen shall be rated as follows:

Free. Not more than a slight discoloration in the lead acetate test, and not more than a "slight trace" of turbidity in the barium sulfate test with no loss in breaking strength above that of a vat dyed cotton specimen of comparable weight.

Slight. Tan to light brown color in the lead acetate test and a "trace" of turbidity in the barium sulfate test, and not more than 7 percent loss in breaking strength above that of vat dyed cotton specimen of comparable weight.

METHOD 2020

Moderate. Dark brown color in the lead acetate test, and a "medium" turbidity in the barium sulfate test, and not more than 20 percent loss in breaking strength above that of a vat dyed cotton specimen of comparable weight.

Severe. Black color in the lead acetate test and "medium heavy" turbidity in the barium sulfate test, and more than a 20 percent loss in breaking strength above that of a vat dyed cotton specimen of comparable weight.

6. REPORT

6.1 The procurement document shall specify that the evaluation shall be made against a standard sample; or when no standard sample has been established, it shall specify the minimum acceptable rating for the amount of labile sulfur present.

6.2 Standard sample. When a standard sample has been established, the amount of labile sulfur shall be reported as "pass" (satisfactory) or "fail" (unsatisfactory) .

6.3 No standard sample. When no standard sample has been established the amount of labile sulfur shall be reported as "pass" or "fail". When failure is reported, the adjective rating, i.e., "free", "slight", "moderate", or "severe" shall also be recorded.

7. NOTES

7.1 A Parr Turbidimeter has been tested and found satisfactory for the described use. However, other devices or means for determining turbidity are equally applicable.

7.2 A Parr Turbidimeter may be obtained from the Arthur H. Thomas Company, Vine St. at Third, P.O. Box 779, Philadelphia, PA 19105 and the Fisher Scientific Company, 711 Forbes Avenue, Pittsburgh, PA 15219.

COPPER CONTENT OF TEXTILES, ELECTROLYTIC METHOD

1. SCOPE

1.1 This method is intended for determining the total copper content of textiles which have been treated with copper compounds. Since some flame retardant finishes contain antimony (the presence of tin, arsenic, antimony, bismuth, or silver interfere with the deposition of copper), the method includes a means of separating antimony before the solution is electrolyzed.

2. TEST SPECIMEN

2.1 Unless otherwise specified in the procurement document, the specimen shall be 2 to 3 g of the material. The material shall be well shredded or cut into small pieces prior to weighing the specimen.

3. NUMBER OF DETERMINATIONS

3.1 Unless otherwise specified in the procurement document, two specimens shall be tested from each sample unit.

4. APPARATUS AND REAGENTS

4.1 Apparatus.4.1.1 Analytical balance.4.1.2 Weighing bottle.4.1.3 Air oven.4.1.4 Desiccator.4.1.5 Pyrex beakers.4.1.6 Watch glass.4.1.7 Hot plate.4.1.8 Beaker tongs.

METHOD 2050

4.1.9 Medicine dropper.4.1.10 Funnel.4.1.11 Filter paper.

4.1.12 Electroanalyzer. Any commercial electroanalyzer that gives accurate results with solutions of known copper content may be used. The most satisfactory cathode is a cylinder of platinum gauze made of sufficiently heavy wire to prevent breaking under normal operating conditions. The anode may be a cylinder of platinum gauze which can be rotated to stir the solution or a stationary spiral of platinum wire with stirring accomplished by means of a mechanically driven glass stirring rod. Higher currents can be used with effective stirring and the time required for the electrolysis correspondingly reduced.

4.2 Reagents. Unless otherwise indicated, all reagents shall be ACS grade.

4.2.1 Oxidant. One part by volume of 70 percent perchloric acid shall be mixed with two parts by volume of 80 percent sulfuric acid. The mixture is available commercially (see 7.1 for safety precautions).

4.2.2 Nitric acid, specific gravity 1.42 to 1.43.

4.2.3 Ammonium hydroxide, specific gravity 0.89 to 0.90.

4.2.4 Ten percent ferric nitrate solution.

4.2.5 Sulfuric acid, specific gravity 1.83 to 1.84.

4.2.6 Ethyl alcohol, 95 percent.

4.2.7 Distilled water.

5 PROCEDURE

5.1 Unless otherwise specified in the procurement document, the specimen shall be placed in a tared weighing bottle, dried in an oven for 2 hours at a temperature of 221° to 230°F (105° to 110°C), cooled to room temperature in a desiccator, weighed to the nearest mg, and the dry weight of the specimen calculated.

5.2 Standard oxidation procedure.

METHOD 2050

5.2.1 The specimen from 5.1 shall be placed in a 400 ml beaker (see 7.2). Twenty to 25 ml of oxidant shall be added. The beaker shall be covered with a footed watch glass, placed on the hot plate in a hood, warmed, and then removed from the hot plate with the beaker tongs. Without removing the watch glass, a few drops of nitric acid shall be added to the contents of the beaker by means of a medicine dropper. Upon completion of any reaction, the beaker shall be gently shaken using the beaker tongs. When any further reaction subsides, a few more drops of nitric acid shall be added and this procedure repeated until the addition of a few drops of nitric acid produces no further reaction. The beaker shall be replaced on the hot plate and the digestion continued until the solution begins to reflux on the sides of the beaker. After a few minutes of refluxing, the beaker shall be removed using the beaker tongs. The contents shall be cooled, cautiously diluted with distilled water to 50 ml., neutralized with ammonium hydroxide, and a slight excess added. If a precipitate forms, the solution shall be filtered into a 250 ml beaker to remove the precipitates of iron, antimony, and other hydroxides. The precipitation of antimony will be complete if there is at least as much iron present as antimony. Should this not be the case, the precipitation may be facilitated by the addition of several drops of 10 percent ferric nitrate solution followed by ammonium hydroxide, in slight excess. The filter paper shall be washed several times using with each wash 5 to 10 ml quantities of distilled water containing 1 or 2 drops of ammonium hydroxide. To the combined filtrate and washings, 5 ml of sulfuric acid and 1 ml of nitric acid shall be added and the contents diluted to approximately 120 ml with distilled water. At this point, the solution shall be acid. The purpose of the above procedures is to destroy the organic matter, remove the interfering ions, and leave the copper in a form suitable for analysis.

5.3 The cleaned cathode shall be dried at a temperature of 221° to 230°F (105° to 110°C), cooled, and weighed to the nearest 0.1 mg. The cathode and anode shall be inserted in their respective holders and the beaker containing the copper solution placed under the electrodes so that the cathode is almost completely immersed. The stirrer shall be rotated at a moderate speed. If necessary to prevent loss of solution during rotation, the beaker may be covered with a split watch glass. A current of approximately 0.5 A shall be applied for about 10 minutes and then increased to 1.5 A. When the solution becomes colorless, without interrupting the current, the sides of the beaker, and the watch glass if used, shall be washed with a stream of water from a wash bottle. The electrolysis shall be continued for 15 minutes. If the portion of the cathode covered by the added wash water shows no copper deposit, the electrolysis has been completed. Otherwise the washing procedure shall be repeated and the electrolytic action continued until no more copper is deposited. With the current still on and the stirrer stopped, the beaker shall be lowered while a stream of distilled water is sprayed over the cathode to wash it free from

METHOD 2050

electrolyte. The cathode shall be removed, dipped in distilled water and then in 95 percent alcohol. The cathode shall be flipped to remove the excess alcohol, dried in the oven at a temperature of 221° to 230°F (105° to 110°C) for 20 to 30 minutes, cooled in a desiccator, and weighed to the nearest 0.1 mg. The increase in weight of the cathode represents the weight of copper in the specimen. The cathode may be cleaned by dipping in dilute nitric acid, 1 volume of concentrated nitric to 3 volumes of water, washing with distilled water, then dipping in 95 percent alcohol, and drying in the oven at 221° to 230°F (105° to 110°C).

5.4 Calculation of results.

5.4.1 Unless otherwise specified in the procurement document, the copper content shall be based on the weight of the oven-dried specimen and shall be calculated as follows:

Copper content, percent =

$$\frac{\text{Weight of copper deposit, g} \times 100}{\text{Weight of specimen, g}}$$

6. REPORT

6.1 The copper content of the sample unit shall be the average of the results obtained from the specimens tested and shall be reported to the nearest 0.01 percent.

6.1.1 The individual values for each specimen used to calculate the average shall be reported.

7. NOTES

7.1 Safety precautions. Seventy percent perchloric acid (72 percent perchloric acid constant boiling at 397°F (203°C)) is stable on storage and may be boiled with safety as long as organic matter is absent. At room temperature it may be mixed with organic matter safely, but such a mixture should never be heated. The oxidant used is a mixture of perchloric acid and sulfuric acid so that the easily oxidized material is destroyed before the temperatures at which perchloric acid is a powerful oxidizing agent are reached. Procedures in which perchloric acid is boiled away should be carried out in hoods made entirely of stone or Transite since it is dangerous to allow perchloric acid fumes to collect on wooden hoods where organic dusts are present. It is not always necessary to boil away the acid, and a cover glass on a beaker is usually sufficient to condense the acid and prevent its escape.

METHOD 2050

7.2 Ashing. Alternatively, the specimen from 5.1 shall be placed in a porcelain crucible and the crucible placed in a cold muffle furnace. The temperature of the furnace shall gradually be raised to $1112^{\circ} \pm 77^{\circ}\text{F}$ ($600^{\circ} \pm 25^{\circ}\text{C}$) and maintained at this temperature for 2 hours. The crucible and contents shall be removed from the furnace and cooled. The contents of the crucible shall be carefully placed in a 250 ml beaker. The oxidant shall be added to the crucible in three aliquot portions to wash any remaining ash into the 250 ml beaker. Ashing is not required in the primary procedure because it requires more time than the oxidation method.

COPPER CONTENT OF TEXTILES, POLAROGRAPHIC METHOD

1. SCOPE

1.1 This method is intended for determining the copper content of textile materials. It is well suited for the routine determination of copper from such compounds as copper naphthenate, copper hydroxynaphthenate, copper-8-quinolinate, or a mixture of these compounds in textiles and retreating compounds. This method is particular applicable to textiles and retreating compounds containing less than one percent of copper. In materials containing higher copper concentrations, the dilution factor in analysis becomes large enough to introduce appreciable error.

2. TEST SPECIMEN

2.1 The specimen shall be approximately 2 to 3 g of the material. The material shall be well shredded or cut into small pieces prior to weighing the specimen.

3. NUMBER OF DETERMINATIONS

3.1 Unless otherwise specified in the procurement document, two specimens shall be tested from each sample unit.

4. APPARATUS AND REAGENTS

4.1 Apparatus.

4.1.1 Polarographic apparatus. The Polarographic apparatus shall consist of a suitable dropping mercury cathode arranged to yield one drop every 3 to 5 seconds, with a cell of approximately 25 ml capacity containing a small pool of mercury as the anode. A source of voltage which may be varied from 0 to minus 1 volt in steps of 50 mv shall be applied across the cell. The current shall be measured with a sensitive galvanometers capable of measuring currents as low as 0.01 microampere and equipped with a series of shunts to vary its sensitivity. Any commercial equipment that gives accurate results with solutions of known copper content may be used.

4.1.2 Weighing bottle.4.1.3 Analytical balance.4.1.4 Air oven.

METHOD 2051

4.1.5 Beaker tongs.

4.1.6 Pyrex beakers.

4.1.7 Hot plate.

4.1.8 Pipette, 1-ml.

4.1.9 Volumetric flasks, 25-ml and 250-ml.

4.2 Reagents.

4.2.1 Copper solution. Standard copper solution 0.0005 g Cu per ml. The standard solution shall be prepared by weighing accurately approximately 0.5 g of pure bright electrolytic sheet copper and dissolving in the minimum amount of dilute, 1 to 1, nitric acid. The solution shall be boiled to remove oxides of nitrogen, cooled and diluted with distilled water to one liter.

4.2.2 Cadmium pilot-ion solution. The cadmium pilot-ion solution shall be prepared by dissolving 1 g of reagent-grade cadmium chloride dihydrate in distilled water, and diluting to 1,000 ml with distilled water.

4.2.3 Saturated sodium sulfite solution.

4.2.4 Gelatin solution (0.2 percent). The gelatin solution shall be prepared by dissolving 2 g of pure gelatin in 100 ml of distilled water, warming on a steam bath if necessary. The solution shall be cooled and diluted with distilled water to 1,000 ml. This solution acts as a maximum suppressor, The solution is not stable and a fresh solution should be prepared prior to testing.

4.2.5 Ammonium chloride - ammonium hydroxide solution. Supporting electrolyte, 2.5 N. The solution shall be prepared by dissolving 134 g of ammonium chloride in distilled water, and adding 325 ml of concentrated ammonium hydroxide. The resulting solution shall be diluted to 1,000 ml with distilled water.

4.2.6 Oxidant. One part by volume of 70 percent perchloric acid shall be mixed with two parts by volume of 80 percent sulfuric acid. The mixture is available commercially.

4.2.7 Nitric acid, specific gravity 1.42 to 1.43.

4.2.8 Ammonium hydroxide, specific gravity 0.90 to 0.91.

4.2.9 Sulfuric acid, specific gravity 1.83 to 1.84.

5. PROCEDURE

5.1 The specimen shall be placed in a tared weighing bottle and dried in the oven for 2 hours at a temperature of 221° to 230°F (105° to 110°C), cooled to room temperature in a desiccator, weighed to the nearest milligram, and the dry weight of the specimen calculated. If the copper content based on the air-dry weight of the specimen is specified, the drying procedure shall be omitted.

5.2 Standard procedure.

5.2.1 The specimen from 5.1 shall be placed in a 250-ml beaker. Twenty to 25 ml of oxidant shall be added. The beaker shall be covered with a footed watch glass, placed on the hot plate in a hood, warmed, and then removed from the hot plate with the beaker tongs. Without removing the watch glass cover, a few drops of nitric acid shall be added to the contents of the beaker by means of a medicine dropper. Upon completion of any reaction, the beaker shall be gently shaken using the beaker tongs. When any further reaction subsides, a few more drops of nitric acid shall be added and this procedure repeated until the addition of a few drops of nitric acid produces no further reaction. The beaker shall be replaced on the hot plate and the digestion continued until the solution begins to reflux on the sides of the beaker. After a few minutes of refluxing, the beaker shall be removed using the beaker tongs, cooled, and the contents cautiously diluted with distilled water and neutralized with ammonium hydroxide. If antimony is present, the hydroxide may precipitate; however, it need not be filtered. The solution shall be cooled and diluted to 250 ml in a volumetric flask. The purpose of the above procedure is to destroy the organic matter, and leave the copper in a form suitable for analysis.

5.3 Obtaining the ratio R_1 for standard copper solution. One ml (pipette)

of the standard copper solution, 1 ml (pipette) of the cadmium solution, 5 ml of the ammonium-chloride solution, 1 ml of the gelatin solution, and 3 ml of the saturated sodium-sulfite solution shall be added to a 25-ml volumetric flask and diluted to the mark with distilled water. This solution shall be added to the cell so that the capillary containing the mercury extends into the liquid, 1 to 2 cm. The potential shall be applied and corresponding galvanometers reading taken at -0.20, -0.45, -0.50, and -0.75 volts. These readings correspond to galvanometers currents A, B, C, and D, respectively, used in the calculation of results in 5.5.

5.4 Obtaining the ratio R_1 for the test copper solution. The procedure in 5.3 shall be repeated, using 10 ml of the solution of the specimen, in lieu of 1 ml of the standard copper solution.

METHOD 2051

5.5 Calculation of results.

5.5.1 The ratio R of the height of the second copper wave to the height of the cadmium wave shall be obtained as follows:

B - A = Height of copper curve between -0.20 and -0.45 volt.
 D - C = Height of cadmium curve between -0.50 and -0.75 volt.
 $R_1 = \frac{B - A}{D - C}$ (for standard copper solution).

$R_2 = \frac{B - A}{D - C}$ (for test copper solution).

S = Milligrams of copper contained in the aliquot of standard solution in 4.3.

The milligrams of copper, E, in the aliquot of the solution of the specimens used, is obtained as follows:

$$E = \frac{S \times R_2}{R_1}$$

5.5.2 Unless otherwise specified in the procurement document, the copper content shall be based on the weight of the oven-dried specimen and shall be calculated as follows:

$$\text{Copper, percent} = \frac{2.5 E}{\text{Weight of specimen, g}}$$

6. REPORT

6.1 The copper content of the sample unit shall be the average of the results obtained from the specimens tested and shall be reported to the nearest 0.01 percent.

6.1.1 The individual values for each specimen used to calculate the average shall be reported.

7. NOTES

7.1 Safety precautions. Seventy percent perchloric acid (72 percent perchloric acid is a constant boiling mixture at 397°F (203°C)) is stable on storage and may be boiled with safety as long as organic matter is absent. At room temperature it may be mixed with organic matter safely, but such a mixture should

METHOD 2051

never be heated. The oxidant used is a mixture of perchloric acid and sulfuric acid so that the easily oxidized material is destroyed before the temperatures at which perchloric acid is a powerful oxidizing agent are reached. Procedures in which perchloric acid is boiled away should be carried out in hoods made entirely of stone or Transite since it is dangerous to allow perchloric acid fumes to collect on wooden hoods where organic dusts are present. It is not always necessary to boil away the acid, and a cover glass on a beaker is usually sufficient to condense the acid and prevent its escape.

SMALL AMOUNTS OF COPPER AND MANGANESE IN TEXTILES

1. SCOPE

1.1 This method is intended to quantitatively determine the amount of copper and manganese present in textile materials, calorimetrically.

2. TEST SPECIMEN

2.1 The test specimen shall be approximately 10 g of the material under test.

3. NUMBER OF DETERMINATIONS

3.1 Unless otherwise specified in the procurement document, two specimens shall be tested from each sample unit.

4. APPARATUS AND REAGENTS

4.1 Apparatus.

4.1.1 Crucible. Coors #3 porcelain, low form, 90 ml capacity.

4.1.2 Tared weighing bottle with cover.

4.1.3 Desiccator.

4.1.4 Nickel-chromium alloy triangle (80:20).

4.1.5 Hydrogen sulfide (H₂S) gas generator.

4.1.6 Porous filtering crucibles. Suitable for retaining fine precipitates.

4.1.7 Colorimetric apparatus.

4.1.7.1 Spectrophotometer or calorimeter (filter photometer) (see Note 1).

4.1.8 Volumetric pipets.

4.1.9 Volumetric flasks with glass stoppers.

4.1.10 Beakers.

METHOD 2053

- 4.1.11 Analytical balance, accurate to 0.001 g.
- 4.1.12 Water bath.
- 4.1.13 Hot plate.
- 4.1.14 Wide mouth, high-form distillation flask.
- 4.1.15 Bunsen burner.
- 4.1.16 Iodine flask.
- 4.2 Reagents (see Note 2).
 - 4.2.1 Standard solutions (see Appendix 1).
 - 4.2.2 Distilled water (copper free) (see Note 3).
 - 4.2.3 Nitric acid. (HNO_3), specific gravity 1.42.
 - 4.2.4 Sulfuric acid. (H_2SO_4), specific gravity 1.84.
 - 4.2.5 Ammonium hydroxide. (NH_4OH), specific gravity 0.90.
 - 4.2.6 Phosphoric acid. (H_3PO_4), 85 percent.
 - 4.2.7 Copper sulfate. ($\text{CuSO}_4 \cdot 5\text{H}_2\text{O}$).
 - 4.2.8 Sodium thiosulfate. ($\text{Na}_2\text{S}_2\text{O}_3 \cdot 5\text{H}_2\text{O}$).
 - 4.2.9 Potassium permanganate. (KMnO_4).
 - 4.2.10 Gum arabic.
 - 4.2.11 Potassium periodate. (KIO_4).
 - 4.2.12 Sodium diethyldithiocarbamate.
- 5. PROCEDURE
 - 5.1 Preparation of specimen.

METHOD 2053

5.1.1 Place weighing bottle with cover in an oven for 1 hour at 221° to 230°F (105° to 110°C). Remove and place in a desiccator until cooled to room temperature. Weigh the bottle and cover. Continue this procedure until a constant weight (± 0.001 g) is reached.

5.1.2 Weight of dry specimen. Cut the specimen (see 2.1) into small pieces and place specimen in the tared weighing bottle and place with the cover in an oven and dry at 221° to 230°F (105° to 110°C) for 2 hours. Cool in a desiccator and weigh. Continue this procedure until a constant weight is attained. Determine the weight of the specimen to the nearest 0.001 g.

5.1.3 Place the weighed specimen in the 90 ml crucible. Heat gently over a low flame from the bunsen burner and continue the heating until the specimen is completely charred. Protect from any strong air currents. Allow to cool and then add 1 ml sulfuric acid and heat again until white fumes stop and only a gray ash remains.

5.1.4 Allow the crucible to cool and then add 20 ml water and 5 ml sulfuric acid. Heat to near boiling for 5 minutes.

5.1.5 Transfer the contents to a 150 ml beaker with repeated rinsing of the crucible with water until a volume of 50 ml is collected.

5.1.6 Warm the 50 ml of solution and pass hydrogen sulfide through the warm solution for 15 minutes. Allow the solution to stand for 1 hour, then filter through a porous filtering crucible. Wash the precipitate with hydrogen sulfide solution (hydrogen sulfide passed through warm water for 15 minutes). Filter as before. Reserve the precipitate for the copper determination. Boil off the hydrogen sulfide from the filtrate and reserve the solution for the manganese determination.

5.2 Prepare a blank.

5.2.1 Add 1 ml of sulfuric acid to a clean, dry crucible. Heat over a low flare until white fumes are no longer given off. Continue the preparation of the blank, repeating steps 5.1.4 through 5.1.6, using the same amount of all reagents.

5.3 Prepare the calibration curves for the determination of copper and manganese (see Appendices 2 and 3).

5.4 Determination of copper.

5.4.1 Dissolve the precipitate (5.1.6) by washing with 30 ml of warm nitric acid (1:2). Cool and make barely alkaline to litmus paper with ammonium hydroxide, cool and transfer the solution to a 50 ml volumetric flask, filtering if necessary, add 10 ml of ammonium hydroxide to the flask, pouring it over the filtrate if filtration is necessary. Dilute the solution to the 50 ml mark with water.

METHOD 2053

5.4.2 Transfer 25 ml of the solution to another 50 ml volumetric flask, add 1 ml gum arabic solution and 10 ml of sodium diethyldithiocarbamate solution. Dilute to volume with water and mix thoroughly.

5.4.3 Transfer a suitable portion of the solution to an absorption cell and measure the transmittance or absorbance at 440 nm or with the same blue filter used to prepare the calibration curve.

5.4.4 To determine the copper in the blank use the precipitate of 5.2.1 and repeat the procedures of 5.4.1 through 5.4.3 using the same amounts of all reagents.

5.5 Calculation for percent copper.

5.5.1 Calculation is made as follows:

$$\text{Copper percent} = \frac{A - B}{C} \times 100 \times 0.5$$

Where: A = Grams copper found in test solution (5.4.3).

B = Grams copper found in blank (5.4.4).

C = Weight of oven-dry specimen in g (5.1.2).

5.6 Determination of manganese.

5.6.1 Transfer filtrate (5.1.6), to 250 ml iodine flask, add 5 ml phosphoric acid and 0.5 g potassium periodate to the solution (see Note 4) and heat to boiling on a hot plate. Remove and place on a steam bath for 30 seconds. Cool to room temperature and transfer to 100 ml volumetric flask, and adjust to volume with treated sulfuric acid (Appendix 1). Measure transmittance or absorbance immediately at 525 nm (spectrophotometer) or with the green filter which ever was used for the preparation of the calibration curve (calorimeter).

5.6.2 To determine the manganese in the blank, use the filtrate of 5.2.1 and repeat the procedure of 5.6.1 using the same amounts of all reagents.

5.7 Calculation for percent manganese.

5.7.1 The calculation is made as follows:

$$\text{Manganese percent} = \frac{A - B}{C} \times 100$$

Where: A = Manganese found in test solution in g (5.6.1).

B = Manganese found in blank in g (5.6.2).

C = Weight of oven-dry specimen in g (5.1.2).

6. REPORT

6.1 Results for each sample unit shall be reported as the average of the specimens tested to the nearest 0.001 percent for copper and to the nearest 0.0001 percent for manganese.

NOTE 1: Calorimetric apparatus for use in this method may be purchased from Bausch and Lomb, 77466 Bausch St., Rochester, NY 14602; Beckman Instruments, 2500 Harbor Boulevard, Fullerton, CA 42634; Fisher Scientific, 711 Forbes Avenue, Pittsburgh, PA 15219.

NOTE 2: Unless otherwise specified, all reagents shall conform to the specifications recommended by the committee on analytical reagents of the American Chemical Society. When acids and ammonium hydroxide are specified by name or chemical formula only, it shall be understood that concentrated reagents of the specific gravities or concentrations as listed are intended. Any dilution of these reagents shall be expressed as a ratio of reagent to water by volume, example: (1:5) means 1 volume of reagent to 5 volumes of water.

NOTE 3: Where water is used throughout this method, it is understood that it will be copper-free distilled water.

NOTE 4: When the expected concentration of manganese is greater than 55 ppm, use an aliquot portion of the filtrate, so that an estimated 0.4 mg is contained in the aliquot portion before adding phosphoric acid and proceeding with the testing.

APPENDIX 1

Preparation of Standard Solutions

1. Copper Standard Solution (1 ml = 0.01 mg Cu). Dissolve 0.3928 g copper sulfate in about 100 ml of water. Transfer to a 250 ml volumetric flask and dilute to the mark with water. Pipet 25 ml of this solution into a 1 liter volumetric flask and dilute to volume. The strength of this solution may be checked by titration with a standard sodium thiosulfate solution.

2. Sodium diethyldithiocarbamate solution (1 g per liter). Dissolve 1 g of the salt in 1 liter of water and store in a brown-glass stoppered bottle. Do not use if over 30 days old.

3. Manganese Standard solution (1 ml = 0.01 mg Mn). Prepare a dilute solution of potassium permanganate by diluting to 1 liter in a volumetric flask a quantity of standard KMnO_4 of known normality, the amount to be determined as follows:

$$A = \frac{4.551}{5N}$$

Where: A = amount (ml) of standard KMnO_4 solution required.

N = normality of the standard KMnO_4 solution used.

Do not keep this solution for more than a week.

4. Sodium Thiosulfate Standard Solution (1 ml = 0.01 mg Cu). Dissolve 0.392 g of sodium thiosulfate in about 50 ml of water. Transfer to a 100 ml volumetric flask and dilute to volume with water. Mix thoroughly, then pipet 10 ml of this solution into a 1 liter volumetric flask and dilute to the mark.

5. Gum Arabic Solution (50 g per liter). Dissolve 5 g of gum arabic in 100 ml of water. Filter through copper-free glass wool if necessary. Do not use this solution if over 30 days old.

6. Treated sulfuric acid. Add 30 ml H_2SO_4 to 1 liter of water. Add 1 g of KIO_4 and boil 3 minutes. Cool to room temperature before using.

APPENDIX 2

Preparation of Calibration Curve for
the Determination of Copper (See Note 1)

Take 150 ml of HNO_3 (1:2). Make barely alkaline to litmus paper with NH_4OH and cool. Transfer to a 250 ml volumetric flask and add 50 ml NH_4OH and dilute to volume with water. Pipet 25 ml portions of this solution into each of nine 50 ml volumetric flasks. Add 1 ml of gum arabic solution and 10 ml of sodium dimethyldithiocarbamate solution to each flask. Pipet 1, 2, 4, 6, 8, 10, 12 and 14 ml portions of copper standard solution (1 ml = 0.01 mg Cu) into eight of the flasks and carry the ninth through as a blank. Dilute the solution in each of the flasks to 50 ml with water.

Transfer a suitable portion of each solution to the absorption cell of the spectrophotometer or colorimeter and measure the transmittance or absorbance at 440 nm or with a blue filter; as appropriate; compensate or correct for the blank. Plot the values obtained against mg of copper per 50 ml of solution.

NOTE 1: With a spectrophotometer, use a narrow band centered about the wavelength specified. With a calorimeter, use a filter that transmits a band of wavelength having a maximum transmittance approximately equal to the specified wavelength. New curves must be prepared whenever a new filter is used, and it is recommended that calibration curves be restandardized at least once every six months.

METHOD 2053

APPENDIX 3

Preparation of Calibration Curve for
the Determination of Manganese

Transfer 10, 15, 20, 25, 30, 40 and 50 ml portions of manganese standard solution (1 ml = 0.01 mg Mn) into seven 100 ml volumetric flasks and dilute to volume with water. Fill an eighth flask with water and carry through as a blank. Transfer a suitable portion of each solution to the absorption cell of the spectrophotometer or calorimeter and determine the transmittance or absorbance at 525 nm or with a green filter. Compensate or correct for the blank. Plot the values obtained against mg of 100 ml of solution (see Note 1, Appendix 2).

FED. TEST METHOD STD. NO. 191A

METHOD 2060
July 20, 1978

COPPER-8-QUINOLINOLATE CONTENT OF TEXTILES,
SPECTROPHOTOMETRIC METHOD

1. SCOPE

1.1 This method is intended for determining the copper-8-quinolinolate or copper as copper-8-quinolinolate content of textiles. The method is suitable for use on textiles treated for fire, water, weather, and mildew resistance.

2. TEST SPECIMEN

2.1 The test specimen shall be a 1 g composite of the material cut into pieces approximately 1/8 inch (3 mm) square, and thoroughly mixed.

3. NUMBER OF DETERMINATIONS

3.1 Unless otherwise specified in the procurement document, two specimens shall be tested from each sample unit.

4. APPARATUS AND REAGENTS

4.1 Apparatus.

4.1.1 Analytical balance. Analytical balance capable of weighing accurately to ± 0.001 g.

4.1.2 Potentiometric pH apparatus. Potentiometric pH apparatus capable of measuring pH to the nearest 0.1 unit.

4.1.3 Separatory funnel. 250 ml.

4.1.4 Spectrophotometer. Spectrophotometer capable of making measurements at 410 nanometers.

4.1.5 Beakers.

4.1.6 Erlenmeyer flasks. 100 ml.

4.1.7 Volumetric flasks. 100 ml.

METHOD 2060

4.1.8 Air oven.

4.2 Reagents.

4.2.1 Sulfuric acid. 10 percent solution, prepared from concentrated sulfuric acid, specific gravity 1.84.

4.2.2 Redistilled chloroform.

4.2.3 Ammoniumhydroxide solution. Concentrated, 25 to 30 percent.

4.2.4 Anhydrous sodium sulfate.

4.2.5 Copper-8-quinolinolate. Reagent grade.

5. PROCEDURE

5.1 Reparation of specimen. Three samples not less than two g each shall be cut from the sample unit. One sample shall be cut from each edge of the sample unit, but will not include the selvage. The third sample shall be taken from the middle of the sample unit. No two samples shall contain the same warp or filling yarns.

5.1.1 The three samples taken from the sample unit shall be cut in small pieces approximately 1/8 inch (3 mm) square and thoroughly mixed to form a composite sample. A one g test specimen shall be taken from the composite sample.

5.2 Weight of dry specimen. The specimen shall be placed in a tared weighing bottle, dried in an oven for 2 hours at a temperature of 212° ±4°F (100° ±2°C), cooled to room temperature in a desiccator, weighed to the nearest mg, and the dry weight of the specimen calculated.

5.3 Determination of copper-8-quinolinolate content.

5.3.1 The weighed specimens shall be immersed in 25 ml of 10 percent sulfuric acid solution contained in a 100 ml Erlenmeyer flask and the solution heated cautiously to 194° to 203°F (90° to 95°C) with shaking. The acid extract shall be decanted into a 250 ml beaker and the extraction repeated twice more with 15 ml portions of the 10 percent sulfuric acid solution, each time heating the solution cautiously to 194° to 203°F (90° to 95°C) with shaking. The solution shall be cooled to room temperature and a sufficient quantity of ammonium hydroxide solution added to the combined acid extracts to adjust the pH of the solution to 6.2 ± 0.2 as measured by a potentiometric pH-meter.

METHOD 2060

5.3.2 The neutralized solution shall be transferred to a 250 ml separator funnel, 5 to 10 ml of redistilled chloroform added, and the separator funnel shaken vigorously for at least 1 minute. The solutions shall be allowed to separate into two distinct layers and the lower layer which is the chloroform layer collected in a 100 ml beaker. Several extractions are necessary for complete separation. The extraction shall be repeated at least twice until the chloroform layer is colorless. Approximately 10 g of anhydrous sodium sulfate shall be added to the combined chloroform extracts, stirred thoroughly, and the solution allowed to stand 5 minutes.

5.3.3 The chloroform solution shall then be carefully decanted into a 100 ml calibrated volumetric flask, washing the sodium sulfate thoroughly with several portions of chloroform. The solution shall then be diluted to the mark with chloroform.

5.3.4 The percent transmittance at 410 nanometers of the above solution shall be read on the spectrophotometer, using as the solvent blank redistilled chloroform. Dilute to an accurately measured volume, if necessary, and base copper-8-quinolinolate content on the adjusted volume.

5.4 Preparation of standard curve. One hundred mg of reagent grade copper-8-quinolinolate which has been dried to a constant weight in an oven at $212^{\circ} + 4^{\circ}\text{F}$ ($100^{\circ} \pm 2^{\circ}\text{C}$) and cooled to room temperature in a desiccator shall be weighed to the nearest 0.1 mg and dissolved in a 10 percent sulfuric acid solution. The solution shall be transferred to a 100 ml volumetric flask and the volume adjusted to the mark with the 10 percent sulfuric acid. Aliquots of 1 ml and whole multiples thereof shall be taken from the points of the curve representing different concentrations of copper-8-quinolinolate. Each aliquot shall be pipetted to a 250 ml beaker and diluted with distilled water to 55 ml. The ammonium hydroxide solution (see 4.2.3) shall be added until the pH of the solution is 6.2 ± 0.2 as measured by a potentiometric pH meter. The procedure from this point shall be as described in 5.3.2. The standard curve should cover a range of 1 mg of copper-8-quinolinolate per 100 ml of chloroform, to 7 mg of copper-8-quinolinolate per 100 ml of chloroform. The curve should be plotted with the two ordinates being percent transmittance and concentration of copper-8-quinolinolate.

5.5 Calculations. Using the calibration curve, read the number of g of copper-8-quinolinolate in the specimen taken. The copper content shall be based on the weight of the oven-dried specimen and shall be calculated as follows:

$$\text{Copper-8-quinolinolate, percent} = \frac{\text{Copper-8-quinolinolate, g}}{\text{Weight of specimen, g}} \times 100$$

$$\begin{array}{l} \text{Copper in copper-8-quinolinolate} \\ \text{percent} \end{array} = \frac{\text{Copper-8-quinolinolate (18.06), g}}{\text{Weight of specimen, g}}$$

METHOD 2060

6. REPORT

6.1 The percent of copper-8-quinolinolate or copper as copper-8-quinolinolate of the sample unit shall be the average of the results obtained from the specimens tested and shall be reported to the nearest 0.01 percent.

6.1.1 The individual values for each individual specimen used to calculate the average shall also be reported.

WOOL CONTENT, ACID METHOD

1. SCOPE

1.1 This method is intended for determining the wool content in cellulosic-wool combinations and blends, when a mechanical separation is impractical. This method is preferred to Method 2101 for cellulosic-wool determinations, to preclude the necessity of a cellulosic correction factor.

2. TEST SPECIMEN

2.1 The test specimen shall be approximately 2 g of the material. Tightly woven, knitted, or felted material shall be cut into pieces not larger than 1/4 inch (6 mm) squares. Highly twisted yarns shall be untwisted.

3. NUMBER OF DETERMINATIONS

3.1 Unless otherwise specified in the procurement document, two specimens shall be tested from each sample unit.

4. APPARATUS, REAGENTS AND METHODS CITED

4.1 Apparatus.

4.1.1 Apparatus as described in Method 2611, and as follows:

4.1.2 Sintered glass filter crucible of coarse porosity.

4.1.3 500 ml beaker.

4.1.4 Suction flask.

4.2 Reagents.

4.2.1 Sulfuric acid. 1 percent solution, by weight, prepared by adding slowly 5.7 ml of 96 percent sulfuric acid (specific gravity 1.84) to 900 ml of distilled water and diluting to 1 liter.

4.2.2 Sulfuric acid. 70 ±1 percent solution, by weight, prepared by adding very slowly 640 ml of 96 percent sulfuric acid (specific gravity 1.84) to 400 ml of distilled water. Cool the mixture to 68°F (20°C), transfer to a 1 liter volumetric flask, and dilute to the mark. The specific gravity of this solution at 60°F (15.5°C) should be between 1.604 and 1.627.

4.2.3 Sodium bicarbonate, NaHCO₃, 2 percent solution.

METHOD 2100

4.2.4 Reagents as described in Methods 2610 or 2611 as applicable.

4.3 Methods cited.

Method 2610, Nonfibrous Materials in Cotton, Acid Method.

Method 2611, Nonfibrous Materials in Cotton, Enzyme Method.

5. PROCEDURE

5.1 Weight of dry specimen. The test specimen shall be placed in a circulating air oven at a temperature of 221° to 230°F (105° to 110°C) to a weight which is constant to ± 0.001 g, cooled in a desiccator, and weighed to the nearest 0.001 g. This is the "Weight of the original dry specimen" and in the calculation of results is designated as "O".

5.2 Weight of dry desized specimen. The specimen shall then be desized and extracted to remove starch and protein content, including chloroform-soluble and water-soluble materials, as described in Method 2611 or 2610, if acid-hydrolyzable materials are present. The specimen shall then be dried in a circulating air oven at a temperature of 221° to 230°F (105° to 110°C) to a weight which is constant to ± 0.001 g, cooled in a desiccator, and weighed to the nearest 0.001 g. This is the "weight of the dry desized specimen", and in the calculation of results is designated as "S".

5.3 Weight of dry wool. The specimen shall be immersed for 7 to 10 minutes in 200 ml of a boiling 1 percent sulfuric acid solution. The solution shall then be filtered through a sintered glass crucible and the excess acid solution removed by suction. The specimen shall then be immersed in 200 ml of a 70 percent sulfuric acid solution at 100°F (38°C) and worked in this solution for 15 minutes, preferable with a mechanical stirring device. The solution shall again be filtered through a sintered glass crucible and the excess acid solution removed by suction. The undissolved fibers in the crucible shall then be washed thoroughly with cold water. The specimen fibers shall then be immersed in a 2 percent solution of sodium bicarbonate at room temperature for 5 minutes to neutralize any acid. The solution shall again be filtered through a crucible and washed thoroughly with water. The residue shall be dried in a circulating air oven at a temperature of 221° to 230°F (105° to 110°C) to a weight which is constant to ± 0.001 g, cooled in a desiccator, and weighed to the nearest 0.001 g. This is the "Weight of the dry wool", and in the calculation of results is designated as "W".

5.4 Calculation of results.

5.4.1 Unless otherwise specified in the procurement document, the wool content of the specimen shall be based on the weight of the original dry specimen and shall be calculated as follows:

$$\text{Wool, percent} = \frac{W}{O} \times 100$$

Where: O = Weight of the original dry specimen, g (5.1).

W = Weight of the dry wool, g (5.3).

5.4.2 When wool content on the basis of the dry desized specimen is specified in the procurement document, the wool content of the specimen shall be calculated as follows:

$$\text{Wool, percent} = \frac{W}{S} \times 100$$

Where: S = Weight of the dry desized specimen, g (5.2).

W = Weight of the dry wool, g (5.3).

6. REPORT

6.1 The wool content of the sample unit shall be the average of the results obtained from the specimens tested and shall be reported to the nearest 0.1 percent.

6.2 Each individual value used in expressing the final result shall also be reported.

WOOL CONTENT, ALKALI METHOD

1. SCOPE

1.1 This method is intended for determining the wool content of cloths and felts of wool fibers and wool-nylon fiber blends, when mechanical separation is impractical. It may be used for cellulosic-wool determinations; however, Method 2100 is preferred, to preclude the necessity of including a correction factor in the calculation of results.

2. TEST SPECIMEN

2.1 The test specimen shall be 2 to 5 g of the material cut into pieces not larger than 1/4 inch (6 mm) squares.

3. NUMBER OF DETERMINATIONS

3.1 Unless otherwise specified in the procurement document, two specimens shall be tested from each sample unit.

4. APPARATUS, REAGENTS AND METHODS CITED

4.1 Apparatus.

4.1.1 Apparatus as described in Method 2611.

4.2 Reagents.

4.2.1 Reagents as described in Methods 2610 or 2611 as applicable.

4.2.2 Sodium hydroxide solution. Sodium hydroxide, 5 percent aqueous solution prepared by dissolving 5.3 g of sodium hydroxide, reagent grade pellets, in water and diluting to 100 ml.

4.2.3 Acetic acid. Acetic acid, 5 percent solution prepared by dissolving 5 ml of glacial acetic acid in water and diluting to 100 ml.

4.3 Methods cited.

Method 2610, Nonfibrous Materials in Cotton, Acid Method.

Method 2611, Nonfibrous Materials in Cotton, Enzyme Method.

METHOD 2101

5. PROCEDURE

5.1 Weight of dry specimen. The specimen shall be placed in a weighing container and dried in a circulating air oven at a temperature of 221° to 230°F (105° to 110°C) to a weight which is constant to + 0.001 g, cooled in a desiccator, and weighed to the nearest 0.001 g. This is the "Weight of the original dry specimen", and in the calculation of results shall be designated as "O".

5.2 Weight of dry desized specimen. The specimen shall then be desized and extracted to remove starch and protein content, including chloroform-soluble and water-soluble materials as described in Method 2611 or 2610, if acid-hydrolyzable materials are present. The specimen shall then be dried in a circulating air oven at a temperature of 221° to 230°F (105° to 110°C) to a weight which is constant to ± 0.001 g, cooled in a desiccator, and weighed to the nearest 0.001 g. This is the "Weight of the dry desized specimen", and in the calculation of results is designated as "S".

5.3 Weight of the fiber residue. The specimen shall then be immersed for 10 minutes in a boiling solution of sodium hydroxide containing 100 ml of solution to each gram of specimen. The solution shall then be filtered through the stainless-steel sieve and washed with three 500 ml portions of hot water, followed by 100 ml portions of a 5 percent acetic acid. Care shall be exercised in washing the fiber residue and removing from the sieve, in order to minimize any loss of fibers. The residue shall be dried in a circulating air oven at a temperature of 221° to 230°F (105° to 110°C) to a weight which is constant to ± 0.001 g, cooled in a desiccator, and weighed to the nearest 0.001 g. This is the "Weight of the fiber residue", and in the calculation of results is designated as "R". The loss in weight due to this treatment is the weight of the wool.

5.4 Calculation of results.

5.4.1 Unless otherwise specified in the procurement document, the wool content of the specimen shall be based on the weight of the original dry specimen, and shall be calculated as follows:

$$\text{Wool, percent} = \frac{S-R}{O} \times 100$$

Where: O = Weight of the original dry specimen, g (5.1).

s = Weight of the dry desized specimen, g (5.2).

R = Weight of the fiber residue, g (5.3).

METHOD 2101

5.4.2 When wool content on the basis of the dry desized specimen is specified in the procurement document, the wool content of the specimen shall be calculated as follows:

$$\text{Wool, percent} = \frac{S-R}{S} \times 100$$

Where: S = Weight of the dry desized specimen, g (5.2).

R = Weight of the fiber residue, g (5.3).

6. REPORT

6.1 The wool content of the sample unit shall be the average of the results obtained from the specimens tested, and shall be reported to the nearest 0.1 percent.

6.2 Each individual value used in expressing the final result shall also be reported.

METHOD 2102
July 20, 1978

WOOL CONTENT, HYPOCHLORITE METHOD

1. SCOPE

1.1 This method is intended for determining the wool content in wool-acrylic, wool-polyester, and other wool-synthetic fiber blends as applicable. The synthetic fiber content may also be determined by this method provided that the blend contains only wool and one synthetic fiber. Methods 2530 or 2101 are preferred for determining the wool content of wool - nylon fiber blends.

2. TEST SPECIMEN

2.1 The test specimen shall be 3 to 4 g of the material cut into pieces not larger than 1/4 inch (6 mm) squares.

3. NUMBER OF DETERMINATIONS

3.1 Unless otherwise specified in the procurement document, two specimens shall be tested from each sample unit.

4. APPARATUS AND REAGENTS

4.1 Apparatus.

4.1.1 Analytical balance. Analytical balance capable of weighing accurately to 0.001 g.

4.1.2 Circulating air oven maintained between 221° to 230°F (105° to 110°C).

4.1.3 250 ml beaker.

4.1.4 Erlenmeyer flask.

4.1.5 Funnel. Buchner type funnel with sintered filter disk of coarse porosity 1

4.2 Reagents.

4.2.1 Chloroform, U.S.P.

4.2.2 Distilled water.

4.2.3 Sodium hypochlorite solution. Any commercial preparation of sodium hypochlorite, NaOCl, diluted to an available chlorine content of 5 to 6 percent by weight.

FED. TEST METHOD STD. NO. 191A

METHOD 2102

4.2.3.1 Since sodium hypochlorite solutions lose strength in storage or on exposure to light, the available chlorine content in the solution shall be determined immediately before using as follows:

4.2.3.1.1 Available chlorine content. A 10 ml aliquot of the sodium-hypochlorite solution, expressed as weight "W" in grams in the calculation, shall be diluted to 250 ml with distilled water in a volumetric flask. Twenty-five ml of this solution shall be added to an Erlenmeyer flask, together with 3 to 5 ml of a 10 percent solution of potassium iodide and 2 to 3 ml of acetic acid. This solution shall then be titrated with 0.1N sodium thiosulfate until the yellow color of the iodine is nearly destroyed. Five ml of a starch solution shall be added and the mixture titrated until the blue color entirely disappears. The percentage of available chlorine by weight shall be calculated as follows:

$$\text{Available chlorine, percent} = \frac{M \times 3.546}{W}$$

Where: M = Milliliters of 0.1N sodium thiosulfate required for titration.

W = Weight of 10 ml aliquot of sodium-hypochlorite solution, g

4.2.4 Sodium bisulfate solution (antichlor). 5 g C.P. sodium bisulfite NaHSO_3 , anhydrous, made up to 1000 ml with distilled water.

5. PROCEDURE

5.1 Weight of dry specimen. The specimen shall be placed in a weighing container and dried in a circulating air oven at a temperature of 221° to 230°F (105° to 110°C) to a weight which is constant to + 0.001 g, cooled in a desiccator, and weighed to the nearest 0.001 g. This is the "Weight of the original dry specimen" and in the calculation of results is designated as "D".

5.2 Weight of dry, chloroform-extracted specimen. The specimen shall be extracted with chloroform for a minimum of 20 extractions in a Soxhlet extractor. The specimen shall then be dried in a circulating air oven at a temperature of 221° to 230°F (105° to 110°C) to a weight which is constant to ±0.001 g, cooled in a desiccator, and weighed to the nearest 0.001 g. This is the "Weight of the dry, chloroform-extracted specimen" and in the calculation of results is designated as "S".

5.3 Weight of fiber residue. The specimen shall then be immersed for a minimum of 20 minutes in 250 ml of the sodium-hypochlorite solution at 68° to 77°F (20° to 25°C) with frequent stirring. The mixture shall then be filtered

METHOD 2102

through the Buchner funnel and undissolved fibers washed free of sodium-hypochlorite with two 250 ml portions of sodium bisulfite solution at a temperature of $90^{\circ} \pm 2^{\circ}\text{F}$ ($32^{\circ} \pm 1^{\circ}\text{C}$) and three 500 ml portions of distilled water. The residue shall then be dried in a circulating air oven at a temperature of 221° to 230°F (105° to 110°C) to a weight which is constant to ± 0.001 g, cooled in a desiccator, and weighed to the nearest 0.001 g. This is the "Weight of the fiber residue" and in calculation of results is designated as "R". The loss in weight due to this treatment is the weight of the wool.

5.4 Calculation of results.

5.4.1 Unless otherwise specified in the procurement document, the wool content or synthetic fiber content of the specimen shall be based on the weight of the original dry specimen and shall be calculated as follows:

$$\text{Wool, percent} = \frac{S - R}{D} \times 100$$

$$\text{Synthetic fiber, percent} = \frac{R}{D} \times 100$$

Where: D = Weight of the original dry specimen, g (see 5.1).

S = Weight of the dry, chloroform-extracted specimen, g (see 5.2).

R = Weight of the fiber residue, g (see 5.3).

5.4.2 When fiber content on the basis of the dry, chloroform-extracted specimen is specified in the procurement document, the wool content or synthetic fiber content of the specimen shall be calculated as follows:

$$\text{Wool, percent} = \frac{S - R}{S} \times 100$$

$$\text{Synthetic fiber, percent} = \frac{R}{S} \times 100$$

Where: S = Weight of the dry, chloroform-extracted specimen, g (see 5.2).

R = Weight of the fiber residue, g (see 5.3).

6. REPORT

6.1 The wool content and/or synthetic fiber content of the sample unit shall be the average of the results obtained from the specimens tested and shall be reported to the nearest 0.1 percent.

6.2 Each individual value used in expressing the final result shall also be reported.

SILK CONTENT OF FIBER MIXTURES

1. SCOPE

1.1 This method is intended for determining the silk content in mixtures with such fibers as casein fibers, cellulose acetate, nylon, wool, cotton, and other vegetable fibers, when mechanical separation is impractical. The method is not intended for determining the silk content of weighted silk.

2. TEST SPECIMEN

2.1 The test specimen shall be 2 to 5 g of the material cut into pieces not larger than 1/4 inch (6 mm) squares.

3. NUMBER OF DETERMINATIONS

3.1 Unless otherwise specified in the procurement document, two specimens shall be tested from each sample unit.

4. APPARATUS AND REAGENTS

4.1 Apparatus.

4.1.1 Analytical balance. Analytical balance capable of weighing accurately to ± 0.001 g.

4.1.2 Water bath. Water bath equipped with heater and a container with mechanical stirrer.

4.1.3 Hydrometer, range 1.20 to 1.40.

4.1.4 Sintered glass Gooch crucible of coarse porosity.

4.1.5 Weighing bottle with ground glass cover.

4.1.6 Soxhlet extraction apparatus.

4.1.7 Stainless steel sieve. 80 to 100 mesh or equivalent.

4.1.8 Desiccator with suitable desiccant. Anhydrous calcium sulfate or anhydrous calcium chloride have been found suitable.

4.2 Reagents.

METHOD 2110

4.2.1 Calcium thiocyanate. (Specific gravity 1.20 to 1.21 at 70°C).

4.2.2 Acetic acid C.P.

4.2.3 Iodine solution. An approximate 0.01N stock solution of iodine (0.13 g of iodine and 2.6 g of potassium iodide in 100 ml of distilled water) may be prepared, and a portion of this diluted to a pale yellow color (about 0.001N) each time a test for starch is made.

4.2.4 Amylolytic and proteolytic enzyme mixture. (see 7.1)

4.2.5 Millon's reagent. Millon's reagent shall be prepared by dissolving 1 ml of mercury in 9 ml of concentrated nitric acid (94 percent) and diluted with 10 ml of distilled water. This preparation shall be made under a hood. Since this reagent is unstable, it shall be freshly prepared.

4.2.6 Acetone. Acetone conforming to O-A-51, Acetone, Technical.

4.2.7 Chloroform. U.S.P.

4.2.8 Acidified ferric sulfate solution.

5. PROCEDURE

5.1 Weight of dry specimen. The specimen shall be placed in a weighing bottle and dried in an oven at a temperature of 221° to 230°F (105° to 110°C), cooled in a desiccator, and weighed to the nearest 0.001 g. This is the "Weight of the dry specimen," and in the calculation of results is indicated as "D".

5.2 Weight of chloroform-soluble material. The dried specimen (see 5.2) shall be extracted with chloroform for a minimum of twenty extractions in a Soxhlet extractor. If the weight of the chloroform-extractable matter is required, the extract shall be dried to constant weight in a tared container at a temperature of 174° to 178°F (79° to 81°C), cooled in a desiccator, and weighed to the nearest 0.001 g. This is the "Weight of chloroform-soluble material," and in the calculation of results is indicated as "C".

5.3 Weight of water-soluble material. The specimen (see 5.2) shall be placed in a Soxhlet extractor with distilled water and subjected to a minimum of ten extractions. If the weight of the water-soluble material is required the extract shall be dried to constant weight in a tared container at a temperature of 212° to 216°F (100° to 102°C), cooled in a desiccator, and weighed to the nearest 0.001 g. This is the "Weight of the water-soluble material" and in the calculation of results is indicated as "W".

5.4 Chloroform and water extractions must be performed in determining starch and protein content. However, the determination for weight of extract, and calculations involved may be omitted when the exact amounts of water and chloroform-soluble material are not required.

5.5 Weight of desized specimen. The specimen (see 5.3) shall be immersed in a suitable aqueous enzyme solution containing both amylolytic and proteolytic components at the concentrations, liquid to fabric ratio, temperature, and length of time required to remove the finish as recommended by the manufacturer of the enzymes. The specimen shall be removed from the enzyme solution on a sieve, squeezed and rinsed, to remove the enzyme solution. This shall be done by alternately squeezing and rinsing the specimen in a minimum of twelve successive baths of distilled water at 154° to 165°F (68° to 74°C). After rinsing, the specimen shall be spot-tested for the presence of starch with iodine solution and for protein with Millon's reagent. The presence of starch is indicated by a blue coloration and the presence of protein by a red coloration. If either test is positive, repeat the enzyme treatment with the required rinsing until the spot-tests are negative. If additional treatments are required, the specimen shall be thoroughly rinsed before repeating the enzyme treatment. After the enzyme solutions have been completely removed from the specimen, the specimen shall be dried to constant weight (± 0.001 g) as described in paragraph 5.2. This is the "Weight of the desized specimen", and in the calculation of results is indicated at "S".

5.6 Removal of cellulose acetate. The specimen shall be placed in a Soxhlet extractor and extracted for at least 3 hours with acetone. The extraction shall be conducted at such a rate that the solvent in the specimen shall change at least three times per hour. The specimen shall be removed from the extractor, squeezed to remove excess acetone, and immersed in warm distilled water for a few minutes. The residual fibers shall be squeezed to remove excess water and dried to constant weight (± 0.001 g) as described in paragraph 5.2. This is known as "Weight of specimen after removal of cellulose acetate" and in the calculation of results is indicated as "A".

5.7 Removal of silk to determine weight of residual fibers. The residue (see 5.6) shall be agitated vigorously for 1 hour in 500 ml of a clear solution of calcium thiocyanate of specific gravity 1.20 to 1.21 at 154° to 162°F (68° to 72°C) made just acid to litmus with acetic acid. Precautions shall be taken to prevent evaporation with consequent concentration of the thiocyanate solution during the treatment. The liquid shall be filtered through a Gooch crucible. After a pad has been formed, the portions of the solution shall be combined, heated to approximately 158°F (70°C), and filtered through the pad with the aid of suction. The fibers shall be removed from the filter and agitated well for 5 minutes in 200 ml of fresh thiocyanate solution at 158°F (70°C), and filtered as before. The fibers shall be washed with hot distilled water until free of thiocyanate, as indicated by a negative test when a drop of

METHOD 2110

acidified ferric sulfate solution is added to a portion of the filtrate (red color indicates the presence of thiocyanate). The fibers shall then be dried to a constant weight (± 0.001 g) at 221° to 230°F (105° to 110°C), cooled in a desiccator and again weighed. This is known as "Weight of residual fibers" and in the calculation of results is known as "R".

5.8 Calculations.

$$5.8.1 \text{ Chloroform-soluble material} = \frac{C}{D} \times 100$$

$$5.8.2 \text{ Water-soluble material} = \frac{W}{D} \times 100$$

5.8.3 If the silk content of the specimen is required, the silk content shall be based on the dry weight of the specimen and shall be calculated as follows:

5.8.3.1 If cellulose acetate is not present:

$$\text{Silk, percent} = \frac{S - R}{D} \times 100 \text{ (see 5.8.5)}$$

5.8.3.2 If cellulose acetate is present:

$$\text{Silk, percent} = \frac{A - R}{D} \times 100 \text{ (see 5.8.5)}$$

5.8.4 If the silk content of the specimen exclusive of the sizing and finishing material is required, the silk content shall be based on the dry weight of the desized specimen and shall be calculated as follows:

5.8.4.1 If cellulose acetate is not present:

$$\text{Silk, desized specimen, percent} = \frac{S - R}{S} \times 100 \text{ (see 5.8.5)}$$

5.8.4.2 If cellulose acetate is present:

$$\text{Silk, desized specimen, percent} = \frac{A - R}{S} \times 100 \text{ (see 5.8.5)}$$

5.8.5 Symbols Used in Formulas:

D = weight of original dry specimen, g (see 5.1).

S = weight of dry desized specimen, g (see 5.5).

METHOD 2110

A = weight of specimen after removal of cellulose acetate, g (see 5.6).

R = weight of residual fibers, g (see 5.7).

C = weight of chloroform-soluble material, g (see 5.2).

W = weight of water-soluble material, g (see 5.3).

6. REPORT

6.1 The silk content of the sample unit shall be the average of the results obtained from the specimens tested and shall be reported to the nearest 1.0 percent.

6.1.1 The individual values for each individual specimen used to calculate the average shall also be reported.

7. NOTES

7.1 The proteolytic and amylolytic enzymes used for removal of starch and protein compounds can be obtained from most chemical supply houses, including the following:

Rohm and Haas Company
Independence Mall West
Philadelphia, PA 19105

Wallerstein Company
125 Lake Avenue
Staten Island, NY 10303

SILK FIBER CONTENT OF SILK TEXTILES (ESPECIALLY WEIGHTED SILK)

1. SCOPE

1.1 This method is intended for determining the silk fiber (fibroin) content of silk textiles, particularly weighted silk.

2. TEST SPECIMEN

2.1 The specimen shall be approximately 3 to 5 g of the material cut into pieces not larger than 1/4 inch (6 mm) squares.

3. NUMBER OF DETERMINATIONS

3.1 Unless otherwise specified in the procurement document, two specimens shall be tested from each sample unit.

4. APPARATUS AND REAGENTS

4.1 Apparatus.

4.1.1 Analytical balance. Analytical balance capable of weighing accurately to ± 0.0001 g.

4.1.2 Weighing bottle with ground glass cover.

4.1.3 Soxhlet extraction apparatus.

4.1.4 Stainless steel sieve. 80 to 100 mesh or equivalent.

4.1.5 Desiccator with suitable desiccant. Anhydrous calcium sulfate or anhydrous calcium chloride have been found suitable.

4.1.6 Water bath. Water bath equipped with heater and a container with mechanical stirrer.

4.2 Reagents.

4.2.1 Diethyl ether.

4.2.2 Ethyl alcohol. 95 percent.

METHOD 2111

4.2.3 Acid solution. Hydrochloric and hydrofluoric acid solution containing 2 percent HCl and 2 percent HF (actual) by weight. This solution contains approximately 45 ml of hydrochloric acid, specific gravity 1.19; and 35 ml of hydrofluoric acid, specific gravity 1.19 in 1000 ml of solution.

4.2.4 Sodium carbonate. 2 percent solution.

5. PROCEDURE

5.1 Preparation of specimen. The material to be tested shall be cut into pieces approximately 1/4 inch (6 mm) square. Care shall be taken to remove loose filaments and yarns from the edge of the squares to prevent loss of filaments due to mechanical action during the treatments.

5.2 Weight of dry specimen. The specimen shall be placed in a weighing bottle and dried in an oven at a temperature of 221° to 230°F (105° to 110°C), cooled in a desiccator, and weighed to the nearest 0.001 g. This is the "Weight of the dry specimen," and in the calculation of results is indicated as "D".

5.3 Determination of silk fiber content.

5.3.1 The dry specimen shall be immersed for about 2 minutes successively in two 30 ml portions of diethyl ether at room temperature and squeezed by hand after each immersion. It shall then be treated similarly with two 30 ml portions of ethyl alcohol at 122° to 140°F (50° to 60°C). It shall then be immersed for 20 minutes in 300 to 500 ml of distilled water at 149° to 158°F (65° to 70°C), squeezed by hand, and then rinsed by immersion for about 1/2 minute each in three fresh portions of distilled water at the same temperature, squeezing after each immersion. A sieve shall be used to collect any loose filaments.

5.3.2 After the specimen has been freed of excess water by squeezing, it shall be immersed for 20 minutes in 300 to 500 ml of a solution containing 2 percent hydrofluoric acid and 2 percent hydrochloric acid at a temperature of 129° to 133°F (54° to 56°C). The acid liquid shall be decanted through the sieve and the specimen shall be rinsed with two portions of distilled water at 131° to 140°F (55° to 60°C), squeezing by hand after each rinse.

5.3.3 The treatment described in 5.3.2 shall be repeated, except that a 2 percent solution of sodium carbonate shall be used in lieu of the acid solution.

5.3.4 Weight of extracted specimen. The treatment described in 5.3.2 shall be applied two more times. Finally, the specimen shall be rinsed free of acid with several portions of distilled water and dried to constant weight

METHOD 2111

in a tared container at a temperature of 174° to 178°F (79° to 81°C), cooled in a desiccator, and weighed to the nearest 0.001 g. This is the "Weight of the extracted specimen" and in the calculation of the results is indicated as "E".

5.3.5 Weight of residual ash. The extracted specimen (see 5.3.4) shall be ashed in a porcelain crucible, heating gently at first, gradually increasing the temperature to dull redness and continuing until the ash is free of carbon. The crucible and contents shall be cooled in a desiccator and weighed to the nearest 0.001 g. This is the "Weight of residual ash" and in the calculation of results is indicated as "R".

5.4 Calculations.

5.4.1 The silk content of the finished fabric shall be based on the dry weight of the specimen and shall be calculated as follows:

$$\text{Silk (fibroin) percent} = \frac{E - R}{D} \times 100$$

Where: D = Weight of original dry specimen, g (see 5.2).

E = Weight of extracted specimen, g (see 5.3.4).

R = Weight of residual ash, g (see 5.3.5).

5.4.2 When silk fiber (fibroin) content on dry extracted specimen basis is specified in the procurement document, the silk fiber content of the specimen shall be calculated as follows:

$$\text{Silk (fibroin) percent} = \frac{E - R}{E} \times 100$$

6. REPORT

6.1 The silk fiber (fibroin) content of the sample unit shall be the average of the results obtained from the specimens tested and shall be reported to the nearest 1.0 percent.

6.1.1 The individual values for each individual specimen used to calculate the average shall also be reported.

CELLULOSE ACETATE CONTENT OF FIBER MIXTURES, ACETIC ACID METHOD

1. SCOPE

1.1 This method is intended for determining the acetic acid soluble cellulose esters in textiles that do not contain nylon. If nylon is present, the cellulose ester's shall be determined by Method 2511.

2. TEST SPECIMEN

2.1 The specimen shall be approximately 5 g of the material cut into pieces not larger than 1/4 inch (6 mm) squares.

3. NUMBER OF DETERMINATIONS

3.1 Unless otherwise specified in the procurement document, two specimens shall be tested from each sample unit.

4. APPARATUS AND REAGENTS

4.1 Apparatus.

4.1.1 Analytical balance. Analytical balance capable of weighing accurately to ± 0.001 g.

4.1.2 Weighing bottle with ground glass cover.

4.1.3 Soxhlet extraction apparatus.

4.1.4 Stainless steel sieve. 80 to 100 mesh or equivalent.

4.1.5 Desiccator with suitable desiccant. Anhydrous calcium sulfate or anhydrous calcium chloride have been found suitable.

4.2 Reagents.

4.2.1 Iodine solution. An approximate 0.01N stock solution of iodine (0.13 g of iodine and 2.6 g of potassium iodide in 100 ml of distilled water) may be prepared, and a portion of this diluted to a pale yellow color (about 0.001N) each time a test for starch is made.

METHOD 2510

4.2.2 Amylolytic and proteolytic enzyme mixture (see 7.1)

4.2.3 Millon's reagent. Millon's reagent shall be prepared by dissolving 1 ml of mercury in 9 ml of concentrated nitric acid (94 percent) and diluted with 10 ml of distilled water. This preparation shall be made under a hood. Since this reagent is unstable, it shall be freshly prepared.

4.2.4 Glacial acetic acid.4.2.5 Ammonium hydroxide.4.2.6 Chloroform, U.S.P.

5. PROCEDURE

5.1 Preparation of specimen. The material to be tested shall be cut into approximately 1/4 inch (6 mm) squares.

5.2 Weight of dry specimen. The specimen shall be placed in a weighing bottle and dried in an oven at a temperature of 221° to 230°F (105° to 110°C), cooled in a desiccator, and weighed to the nearest 0.001 g. This is the "weight of the dry specimen", and in the calculation of results is indicated as "D".

5.3 Weight of chloroform-soluble material. The dried specimen (see 5.2) shall be extracted with chloroform for a minimum of 20 extractions in a Soxhlet extractor. If the weight of the chloroform-extractable matter is required, the extract shall be dried to constant weight in a tared container at a temperature of 174° to 178°F (79° to 81°C), cooled in a desiccator and weighed to the nearest 0.001 g. This is the "Weight of chloroform-soluble material" and in the calculation of results is indicated as "C".

5.4 Weight of water-soluble material. The specimen (see 5.3) shall be placed in a Soxhlet extractor with distilled water and subjected to a minimum of ten extractions. If the weight of the water-soluble material is required, the extract shall be dried to constant weight in a tared container at a temperature of 212° to 216°F (100° to 102°C), cooled in a desiccator and weighed to the nearest 0.001 g. This is the "Weight of the water-soluble material," and in the calculation of results is indicated as "W".

5.5 Chloroform and water extractions must be performed in determining starch and protein content. However, the determination for weight of extract, and calculations involved, may be omitted when the exact amounts of water and chloroform-soluble material are not required.

METHOD 2510

5.6 Weight of desized specimen. The specimen (see 5.4) shall be immersed in a suitable aqueous enzyme solution containing both amyolytic and proteolytic components at the concentrations, liquid to fabric ratio, temperature, and length of time required to remove the finish as recommended by the manufacturer of the enzymes. The specimen shall be removed from the enzyme solution on a sieve, squeezed and rinsed to remove the enzyme solution. This shall be done by alternately squeezing and rinsing the specimen in a minimum of twelve successive baths of distilled water at 154° to 165°F (68° to 74°C). After rinsing, the specimen shall be spot-tested for the presence of starch with the iodine solution and for protein with Millon's reagent. The presence of starch is indicated by a blue coloration and the presence of protein by a red coloration. If either test is positive, repeat the enzyme treatment with the required rinsing until the spot-tests are negative. If additional treatments are required, the specimen shall be thoroughly rinsed before repeating the enzyme treatment. After the enzyme solutions have been completely removed from the specimen, the specimen shall be dried to constant weight (± 0.001 g) as described in para. 5.2. This is the "Weight of the desized specimen", and in the calculation of results is indicated as "S".

5.7 Weight of residual fiber. The desized material shall be extracted three times with glacial acetic acid in a beaker using 200 ml portions with constant agitation for 15 minutes and neutralize with ammonium hydroxide at room temperature. The residue shall be washed in the sieve with hot distilled water at 158°F (70°C) until free of ammonium salts. The residue shall be squeezed to remove excess water and dried to a constant weight (± 0.001 g) as described in para. 5.2. This is the "Weight of residual fiber", and in the calculation of results is indicated as "R".

5.8 Calculation of results.

$$5.8.1 \text{ Chloroform-soluble material} = \frac{C}{D} \times 100$$

$$5.8.2 \text{ Water-soluble material} = \frac{W}{D} \times 100$$

5.8.3 If the cellulose acetate content of the finished fabric is required, the cellulose acetate content shall be based on the dry weight of the specimen and shall be calculated as follows:

$$\text{Cellulose acetate, percent} = \frac{S - R}{D} \times 100 \text{ (see 5.8.5)}$$

5.8.4 If the cellulose acetate content of the fabric, exclusive of sizing and finishing material is required, the cellulose acetate content shall be based on the dry weight of the desized specimen and shall be calculated as follows:

METHOD 2510

$$\text{Cellulose acetate, percent} = \frac{S - R}{S} \times 100 \text{ (see 5.8.5)}$$

5.8.5 Symbols in formulas:

D = weight of original dry specimen, g (see 5.2).

C = weight of chloroform-soluble material, g (see 5.3).

W = weight of water-soluble material, g (see 5.4).

S = weight of dry desized specimen, g (see 5.6).

R = weight of residual fiber, g (see 5.7).

60 REPORT

6.1 The cellulose acetate content of the sample unit shall be the average of the results obtained from the specimens tested and shall be reported to the nearest 1.0 percent.

6.1.1 The individual values for each individual specimen used to calculate the average shall also be reported.

7. NOTES

7.1 The proteolytic and amylolytic enzymes used for removal of starch and protein compounds can be obtained from most chemical supply houses, including the following:

Wallerstein Company
125 Lake Ave.
Staten Island, NY 10303

Rohm & Haas Company
Independence Mall West
Philadelphia, PA 19105

METHOD 2511
July 20, 1978

CELLULOSE ACETATE CONTENT OF FIBER MIXTURES, ACETONE METHOD

1. SCOPE

1.1 This method is intended for determining the acetone soluble cellulose esters in textiles. It is not applicable to all cellulose esters but can be used to separate most cellulose esters in the presence of nylon.

2. TEST SPECIMEN

2.1 The specimen shall be 2 to 5 g of the fabric with the edges fringed to prevent loss of the material.

30 NUMBER OF DETERMINATIONS

3.1 Unless otherwise specified in the procurement document, two specimens shall be tested from each sample unit.

4. APPARATUS AND REAGENTS

4.1 Apparatus.

4.1.1 Analytical balance. Analytical balance capable of weighing accurately to ± 0.001 g.

4.1.2 Weighing bottle with ground glass cover.

4.1.3 Soxhlet extraction apparatus.

4.1.4 Stainless steel sieve, 80 to 100 mesh or equivalent.

4.1.5 Desiccator with suitable desiccant. Anhydrous calcium sulfate or anhydrous calcium chloride have been found suitable.

4.2 Reagents.

4.2.1 Chloroform, U.S.P.

4.2.2 Iodine solution. An approximate 0.01N stock solution of iodine (0.13 g of iodine and 2.6 g of KI in 100 ml of water) may be prepared, and a portion of this diluted to a pale yellow color (about 0.001N) each time a test for starch is made.

FED. TEST METHOD STD. NO. 191A

METHOD 2511

4.2.3 Amylolytic and proteolytic enzyme mixture (see 7.1)

4.2.4 Acetone. Acetone, grade A, conforming to O-A-51, Acetone, Technical.

4.2.5 Millon's reagent. Millon's reagent shall be prepared by adding 25 g (17.6 ml) concentrated nitric acid (specific gravity 1.42) to 25 g (1.84 ml) of mercury under a hood. Upon completion of the reaction, the solution shall be diluted by adding an equal volume of distilled water.

5. PROCEDURE

5.1 Weight of dry specimen. The specimen shall be placed in a weighing bottle and dried in an oven at a temperature of 221° to 230°F (105° to 110°C), cooled in a desiccator, and weighed to the nearest 0.001 g. This is the "Weight of the dry specimen", and in the calculation of results is indicated as "D".

5.2 Weight of chloroform-soluble material. The dried specimen from 5.1 shall be extracted with chloroform for a minimum of 20 extractions in Soxhlet extractor. If the weight of the chloroform-extractable matter is required, the extract shall be dried to constant weight in a tared container at a temperature of 174° to 178°F (79° to 81°C), cooled in a desiccator, and weighed to the nearest 0.001 g. This is the "Weight of chloroform-soluble material", and in the calculation of results is indicated as "C".

5.3 Weight of water-soluble material. The specimen from 5.2 shall be placed in a Soxhlet extractor with distilled water and subjected to a minimum of 10 extractions. If the weight of the water-soluble material is required, the extract shall be dried to constant weight in a tared container at a temperature of 212° to 216°F (100° to 102°C), cooled in a desiccator, and weighed to the nearest 0.001 g. This is the "Weight of the water-soluble material", and in the calculation of results is indicated as "W". Chloroform and water extractions must be performed in determining starch and protein content. However, the determination for weight of extract, and calculations involved may be omitted when the exact amounts of water- and chloroform-soluble material are not required.

5.4 Weight of desized specimen. The specimen from 5.3 shall then be immersed in a suitable aqueous enzyme solution containing both amylolytic and proteolytic components at the concentrations, liquid to fabric ratio temperature, and length of time required to remove the finish as recommended by the manufacturer of the enzymes. The specimen shall be removed from the enzyme solution on a sieve, squeezed and rinsed to remove the enzyme solution. This shall be done by alternately squeezing and rinsing the specimen in a minimum of 12 successive baths of distilled water at 154° to 165°F (68°C to 74°C). After rinsing, the specimen shall be spot-tested for the presence of starch with the iodine solution and for protein with Millon's reagent. The presence of starch is indicated by a blue coloration and the presence of protein by a red

METHOD 2511

coloration. If either test is positive, repeat the enzyme treatment with the required rinsing until the spot-tests are negative. If additional treatments are required, the specimen shall be thoroughly rinsed before repeating the enzyme treatment. After the enzyme solutions have been completely removed from the specimen, the specimen shall be dried to constant weight (see 5.2) and weighed to the nearest 0.001 g. This is the "Weight of the desized specimen", and in the calculation of results is indicated as "S".

5.5 Weight of residual fiber. The desized material shall be placed in a Soxhlet extractor and extracted for at least 3 hours with acetone. The extraction shall be conducted at such a rate that the solvent in the specimen shall change at least three times per hour. The specimen shall be removed from the extractor, squeezed to remove excess acetone, and immersed in warm distilled water for a few minutes. The residual fibers shall be squeezed to remove excess water and dried to constant weight (0.001 g) as described in paragraph 5.2. This is the "Weight of residual fiber", and in the calculation of results is indicated as "R".

5.6 Calculation of results.

$$5.6.1 \text{ Chloroform-soluble material} = \frac{C}{D} \times 100$$

$$5.6.2 \text{ Water-soluble material} = \frac{W}{D} \times 100$$

5.6.3 If the cellulose acetate content of the finished fabric is required, the cellulose acetate content shall be based on the dry weight of the specimen and shall be calculated as follows:

$$\text{Cellulose acetate, percent} = \frac{S-R}{T} \times 100 \text{ (see 5.6.5)}$$

5.6.4 If the cellulose acetate content of the fabric, exclusive of sizing and finishing material is required, the cellulose acetate content shall be based on the dry weight of the desized specimen and shall be calculated as follows:

$$\text{Cellulose acetate, percent} = \frac{S-R}{T} \times 100 \text{ (see 5.6.5).}$$

5.6.5 Symbols in formulas:

D = weight of original dry specimen, g (see 5.1).

C = weight of chloroform-soluble material, g (see 5.2).

w = weight of water-soluble material, g (see 5.3).

METHOD 2511

S = weight of dry desized specimen, g (see 5.4).

R = weight of residual fiber, g (see 5.5).

6. REPORT

6.1 The cellulose acetate content of the sample unit shall be the average of results obtained from the specimens tested and shall be reported to the nearest 1.0 percent.

6.1.1 The individual values for each individual specimen used to calculate the average shall also be reported.

7. NOTES

7.1 The proteolytic and amylolytic enzymes used for removal of starch and protein compounds can be obtained from most chemical supply houses, including the following:

Wallerstein Company
125 Lake Avenue
Staten Island, NY 10303

Rohm & Haas Company
Independence Mall West
Philadelphia, PA 19105

NYLON CONTENT OF FIBER MIXTURES

1. SCOPE

1.1 This method is intended for determining the nylon content of fiber mixtures. It is applicable to the determination of nylon when mixed with the following fibers: cotton, wool, viscose rayon, cellulose acetate, and vinyon.

2. TEST SPECIMEN

2.1 The specimen shall be 2 to 5 g of the material cut into pieces approximately 1/4 inch (6 mm) square.

3. NUMBER OF DETERMINATIONS

3.1 Unless otherwise specified in the procurement document, two specimens shall be tested from each sample unit.

4. APPARATUS AND REAGENTS

4.1 Apparatus.

4.1.1 Analytical balance. Analytical balance capable of weighing accurately to ± 0.001 g.

4.1.2 Weighing bottle with ground glass cover.

4.1.3 Soxhlet extraction apparatus.

4.1.4 Stainless steel sieve, 80 to 100 mesh or equivalent.

4.1.5 Desiccator with suitable desiccant. Anhydrous calcium sulfate or anhydrous calcium chloride have been found suitable.

4.1.6 Buchner funnel. Buchner funnel with sintered glass filter disk of coarse porosity.

4.1.7 Beaker, 400 ml.

4.2 Reagents.

METHOD 2530

4.2.1 Iodine solution. An approximate 0.01N stock solution of iodine (0.13 g of iodine and 2.6 g of potassium iodide in 100 ml of distilled water) may be prepared, and a portion of this diluted to a pale yellow color (about 0.001N) each time a test for starch is made.

4.2.2 Amylolytic and proteolytic enzyme mixture (see 7.1).

4.2.3 Millon's reagent. Millon's reagent shall be prepared by dissolving 1 ml of mercury in 9 ml of concentrated nitric acid (94 percent) and diluted with 10 ml of distilled water. This preparation shall be made under a hood. Since this reagent is unstable, it shall be freshly prepared.

4.2.4 Acetone. Acetone conforming to O-A-51, Acetone, Technical.

4.2.5 Ninety percent formic acid solution.

4.2.6 Chloroform, U.S.P.

5. PROCEDURE

5.1 Weight of dry specimen. The specimen shall be placed in a weighing bottle and dried in an oven at a temperature of 221° to 230°F (105° to 110°C), cooled in a desiccator, and weighed to the nearest 0.001 g. This is the "Weight of the dry specimen," and in the calculation of results is indicated as "D".

5.2 Weight of chloroform-soluble material. The dried specimen (see 5.1) shall be extracted with chloroform for a minimum of 20 extractions in a Soxhlet extractor. If the weight of the chloroform-extractable matter is required, the extract shall be dried to constant weight in a tared container at a temperature of 174° to 178°F (79° to 81°C), cooled in a desiccator, and weighed to the nearest 0.001 g. This is the "Weight of chloroform-soluble material" and in the calculation of results is indicated as "C".

5.3 Weight of water-soluble material. The specimen (see 5.2) shall be placed in a Soxhlet extractor with distilled water and subjected to a minimum of ten extractions. If the weight of the material is required, the extract shall be dried to constant weight in a tared container at a temperature of 212° to 216°F (100° to 102°C), cooled in a desiccator, and weighed to the nearest 0.001 g. This is the "Weight of the water-soluble material", and in the calculation of results is indicated as "W".

5.4 Chloroform and water extractions must be performed in determining starch and protein content. However, the determination for weight of extract, and calculations involved, may be omitted when the exact amounts of water and chloroform-soluble material are not required.

METHOD 2530

5.5 Weight of desized specimen. The specimen (see 5.3) shall then be immersed in a suitable aqueous enzyme solution containing both amylolytic and proteolytic components at the concentrations, liquid to fabric ratio, temperature, and length of time required to remove the finish as recommended by the manufacturer of the enzymes. The specimen shall be removed from the enzyme solution on a sieve, squeezed and rinsed to remove the enzyme solution. This shall be done by alternately squeezing and rinsing the specimen in a minimum of twelve successive baths of distilled water at 154° to 165°F (68° to 74°C). After rinsing, the specimen shall be spot-tested for the presence of starch with the iodine solution and for protein with Millon's reagent. The presence of starch is indicated by a blue coloration and the presence of protein by a red coloration. If either test is positive, repeat the enzyme treatment with the required rinsing until the spot-tests are negative. If additional treatments are required, the specimen shall be thoroughly rinsed before repeating the enzyme treatment. After the enzyme solutions have been completely removed from the specimen, the specimen shall be dried to constant weight (± 0.001 g) as described in 5.2. This is the "Weight of the desized specimen, and in the calculation of results is indicated as "S".

5.6 Weight of specimen after removal of cellulose acetate. The specimen shall be placed in a Soxhlet extractor and extracted for at least 3 hours with acetone. The extractions shall be conducted at such a rate that the solvent in the specimen shall change at least three times per hour. The specimen shall be removed from the extractor, squeezed to remove excess acetone, and immersed in warm distilled water for a few minutes. The residual fibers shall be squeezed to remove excess water and dried to constant weight (± 0.001 g) as described in para. 5.2. This is the "Weight of specimen after removal of cellulose acetate" and in the calculation of results is indicated as "E".

5.7 Weight of residual fibers. The residual fiber shall be immersed in 400 ml of 90 percent formic acid solution and shaken or stirred for 30 minutes at room temperature not over 90°F (32°C). The remaining fibers and solution shall be poured into the funnel and washed with two portions of 100 ml of 90 percent formic acid solution. The second wash shall be tested for presence of nylon by placing a drop in water. If it clouds up, the fibers shall be washed free of nylon with successive portions of 90 percent formic acid. The fibers shall be washed free of acid with two portions of 100 ml hot water. The residue shall be squeezed to remove excess water and dried to a constant weight, (± 0.001 g) as described in para. 5.2. This is the "Weight of residual fibers" and in the calculation of results is indicated as "R".

5.8 Calculation of results.

5.8.1 Chloroform soluble material = $\frac{C}{D} \times 100$

METHOD 2530

$$5.8.2 \text{ Water-soluble material} = \frac{W}{D} \times 100$$

5.8.3 If the nylon content of the finished fabric is required, the nylon content shall be based on the dry weight of the specimen and shall be calculated as follows:

5.8.3.1 If cellulose acetate is not present:

$$\text{Nylon, percent} = \frac{S - R}{D} \times 100 \text{ (see 5.8.5)}$$

5.8.3.2 If cellulose acetate is present:

$$\text{Nylon, percent} = \frac{E - R}{D} \times 100 \text{ (see 5.8.5)}$$

5.8.4 If the nylon content of the fabric, exclusive of sizings and finishing materials is required, the nylon content shall be based on the dry weight of the desized specimen and shall be calculated as follows:

5.8.4.1 If cellulose acetate is not present:

$$\text{Nylon, percent} = \frac{S - R}{S} \times 100 \text{ (see 5.8.5)}$$

5.8.4.2 If cellulose acetate is present:

$$\text{Nylon, percent} = \frac{E - R}{S} \times 100 \text{ (see 5.8.5)}$$

5.8.5 Symbols in formulas:

D = weight of original dry specimen, g (see 5.1)

C = weight of chloroform-soluble material, g (see 5.2)

W = weight of water-soluble material, g (see 5.3)

S = weight of dry desized specimen, g (see 5.5)

E = weight of specimen after removal of cellulose acetate, g (see 5.6)

R = weight of residual fibers, g (see 5.7)

METHOD 2530

6. REPORT

6.1 The nylon content of the sample unit shall be the average of the results obtained from the specimens tested and shall be reported to the nearest 1.0 percent.

6.1.1 The individual values for each individual specimen used to calculate the average shall also be reported.

7. NOTES

7.1 The proteolytic and amylolytic enzymes used for removal of starch and protein compounds can be obtained from most chemical supply houses, including the following:

Wallerstein Company
125 Lake Avenue
Staten Island, NY 10303

Rohm and Haas Company
Independence Mall West
Philadelphia, PA 19105

POLYESTER CONTENT OF FIBER MIXTURES

1. SCOPE

1.1 This method is intended for determining the polyester content of fiber mixtures. It is applicable to the determination of polyester when mixed with the following fibers: cotton, and viscose rayon.

2. TEST SPECIMEN

2.1 The specimen shall be approximately 2 g of the material cut into 1/4 inch (6 mm) squares.

3. NUMBER OF DETERMINATIONS

3.1 Unless otherwise specified in the procurement document, two specimens shall be tested from each sample unit.

4. APPARATUS, REAGENTS AND METHOD CITED

4.1 Apparatus.

4.1.1 Apparatus as described in Method 2611.

4.1.2 Sintered glass filter crucible of coarse porosity.

4.1.3 Hydrometer.

4.2 Reagents.

4.2.1 Sulfuric acid, 70 percent. (Density 1.5989 to 1.6221 g/ml) prepared by first pouring 434 ml of water in a round-bottom flask, then adding 566 ml of concentrated sulfuric acid slowly, with cooling under the tap. The density of the solution is adjusted to 1.5989 to 1.6221 g/ml using a hydrometer at 68°F (20°C).

4.2.2 Sulfuric acid, diluted. 100 ml of concentrated sulfuric acid added to 1900 ml of water.

4.2.3 Ammonia solution, diluted.

METHOD 2535

4.2.4 Distilled water.4.3 Method cited.

Method 2611, Nonfibrous Materials in Cotton, Enzyme Method

5. PROCEDURE

5.1 Weight of dry desized specimen. The nonfibrous material shall be removed as specified in Method 2611, then the desized specimen shall be dried to constant weight, cooled in a desiccator and weighed to the nearest 0.001 g. This is the "Weight of the dry desized specimen".

5.2 Weight of dry polyester fiber. The specimen shall then be immersed in 200 ml of 75 Percent solution of sulfuric acid for 1 hour with intermittent stirring. The residual fibers shall be transferred to the glass crucible and the excess acid solution removed by suction. The residual fibers shall be washed on the fiber filter successively with dilute sulfuric acid, water, dilute ammonia solution (soak for 10 minutes) and again with water (soak for 10 minutes). After each separate washing, the crucible is drained by suction. The residue shall be dried to a constant weight in the air oven at 221° to 230°F (105° to 110°C) and weighed to the nearest 0.001 g. This is the "Weight of the dry polyester fiber" in the specimen.

5.3 Calculation of results.

5.3.1 The percent polyester shall be calculated as follows:

$$\text{Polyester fiber, percent} = \frac{\text{Weight of dry polyester fiber}}{\text{Weight of dry desized specimen}} \times 100$$

6. REPORT

6.1 The polyester fiber content of the sample unit shall be the average of the results obtained from the specimens tested and shall be reported to the nearest 1.0 percent.

MOISTURE CONTENT, OVEN METHOD

1. SCOPE

1.1 This method is intended for determining the moisture content present in textiles. It is applicable to textiles that are not injured by heating to 230°F (110°C), but is not applicable to textiles that have been finished with resins and wax water-repellents applied by a solvent method.

2. TEST SPECIMEN

2.1 Unless otherwise specified in the procurement document, the specimen shall be at least 10 g of the material.

3. NUMBER OF DETERMINATIONS

3.1 Unless otherwise specified in the procurement document, two specimens shall be tested from each sample unit.

4. APPARATUS

4.1 Analytical balance. Analytical balance capable of weighing accurately to ± 0.001 g.

4.2 Weighing bottle or can. Glass weighing bottle of approximately 100 ml capacity fitted with a ground glass cover or an aluminum weighing can of the same capacity with a tight-fitting cover.

4.3 Air oven. Circulating air oven thermostatically controlled, capable of maintaining temperature at 221° to 230°F (105° to 110°C).

4.4 Pair of tongs.

4.5 Desiccator with suitable desiccant. Anhydrous calcium sulfate or anhydrous calcium chloride have been found suitable.

5. PROCEDURE

5.1 Weight of conditioned specimen. When the moisture content of the conditioned material is required, the specimen shall be conditioned in accordance with Section 4 of this Standard and then weighed to the nearest 0.001 g. The weight found shall be the conditioned "Original weight of the specimen".

METHOD 2600

5.2 Weight of specimen. When the moisture content is required of the material is submitted, the specimen shall be delivered to the testing laboratory in a sealed, moisture-proof receptacle of the smallest possible volume. The maximum weight of the receptacle and specimen shall be approximately 100 g. The sealed receptacle with the specimen shall be weighed to the nearest 0.003 g as received, the specimen removed, and the receptacle reweighed. The difference between the weight of the unopened receptacle and of the receptacle alone shall be the submitted "Original weight of the specimen".

5.2.1 Weight of weighing container. The glass weighing-bottle and cover, or the aluminum weighing can and cover, shall be dried at 221° to 230°F (105° to 110°C), to constant-weight. The container and cover shall be placed separately in the oven. After drying for 1 hour, the container and cover shall be transferred, using clean tongs, to a desiccator and allowed to cool to room temperature over a suitable desiccating agent. The container and cover shall then be weighed. The heating, cooling, and weighing cycle shall be repeated until the weight is constant within ± 0.003 g. This is the "Weight of the weighing container". The container shall be kept in a desiccator when not in use.

5.2.2 Dry weight of specimen. The uncovered container with specimen shall be placed in the oven for not less than 1.5 hours at a temperature 221° to 230°F (105° to 110°C). The container shall be covered and quickly transferred to a desiccator. After cooling to room temperature, the container and specimen shall be weighed. The specimen and container shall be returned to the oven and the drying, cooling, and weighing cycle repeated until the weight is constant within ± 0.003 g. The weight of the container (see 5.2.1), shall be subtracted from this weight to obtain the "Dry weight of the specimen."

5.3 Calculation of results.

5.3.1 The moisture content shall be calculated as follows:

$$\text{Moisture content of specimen, percent} = \frac{O-D}{O} \times 100$$

Where:

O = original weight of specimen, g (see 5.1 or 5.2)
D = dry weight of specimen, g (see 5.2.2)

6. REPORT

6.1 The moisture content of the sample unit shall be the average of the results obtained from the specimens tested and shall be reported to the nearest 0.1 percent.

6.2 The individual values used to calculate the average shall also be reported.

MOISTURE CONTENT, OVEN-BALANCE METHOD

1. SCOPE

1.1 This method is intended for determining the moisture content, present in textiles. It is applicable to textiles that are not injured by heating to 230°F (110°C), but is not applicable to textiles that have been finished with resins and wax water-repellents applied by a solvent method. This method is considered adequate for normal inspection purposes. However, in case of dispute or disagreement, Method 2600 should be used.

2. TEST SPECIMEN

2.1 Unless otherwise specified in the procurement document, the specimen shall be at least 10 g of the material.

3. NUMBER OF DETERMINATIONS

3.1 Unless otherwise specified in the procurement document, two specimens shall be tested from each sample unit.

4. APPARATUS

4.1 Analytical balance. Analytical balance capable of weighing accurately to ± 0.001 g.

4.2 Air oven. Circulating air oven thermostatically controlled, capable of maintaining temperature at 221° to 230°F (105° to 110°C), with a balance mounted over it and having a basket for the specimen suspended in the oven from one arm of the balance.

5. PROCEDURE

5.1 Weight of conditioned specimen. When the moisture content of the conditioned material is required, the specimen shall be conditioned in accordance with section 4 of this Standard and then weighed to the nearest 0.01 g. The weight found shall be the conditioned "Original weight of the specimen".

5.2 Weight of specimen. When the moisture content is required of the material as submitted, the specimen shall be delivered to the testing laboratory in a sealed, moisture--proof receptacle of the smallest possible volume. The maximum weight of the receptacle and specimen shall be approximately 100 g. The sealed receptacle with the specimen shall be weighed

METHOD 2601

to the nearest 0.02 g as received, the specimen removed, and the receptacle reweighed. The difference between the weight of the unopened receptacle and of the receptacle alone shall be the submitted "Original weight of the specimen".

5.2.1 The weighing basket shall be placed in the drying oven and dried at a temperature of 221° to 230°F (105° to 110°C), to a constant weight \pm 0.02 g. The fans and drafts shall be cut off during all weighing periods.

5.2.2 Dry weight of specimen. The weighed specimen shall be placed in the basket and dried at a temperature of 221° to 230°F (105° to 110°C) for not less than 1.5 hours and weighed in the oven with fans and drafts cut off. The drying and weighing cycle shall be repeated until the weight is constant within \pm 0.02 g. The weight of the basket (see 5.2.1), shall be subtracted from this weight to obtain the "Dry weight of the specimen".

5.3 Calculation of results.

5.3.1 The moisture content shall be calculated as follows:

$$\text{Moisture content, percent} = \frac{O-D}{O} \times 100$$

Where:

O = original weight of specimen, g (see 5.1 or 5.2)

D = Dry weight of specimen, g (see 5.2.2)

6. REPORT

6.1 The moisture content of the sample unit shall be the average of the results obtained from the specimens tested and shall be reported to the nearest 0.2 percent.

6.2 The individual values used to calculate the average shall also be reported.

METHOD 2610
July 20, 1978

NONFIBROUS MATERIALS IN COTTON, ACID METHOD

1. SCOPE

1.1 This method is intended for use in determining the amount of acid-hydrolyzable materials such as urea formaldehyde condensates which are not removed by Method 2611. It may also be used for determining sizing and other finishing on textile materials when check results with Method 2611 indicate that there is not a significant difference in the two methods. This method is not applicable for determining small amounts of starches in cellulosic textile materials because the loss of cellulose may be large in comparison with the amount of starch present in the fabric.

2. TEST SPECIMEN

2.1 The specimen shall be approximately 10 g of the material. It shall be cut on the bias, have the edges unraveled, or otherwise prepared to prevent loss of fibers in the mechanical action during treatments.

3. NUMBER OF DETERMINATIONS

3.1 Unless otherwise specified in the procurement document, two specimens shall be tested from each sample unit.

4. APPARATUS AND REAGENTS

4.1 Apparatus.

4.1.1 Analytical balance. Analytical balance capable of weighing accurately to + 0.001 g.

4.1.2 Weighing bottle with ground glass cover.

4.1.3 Soxhlet extraction apparatus.

4.1.4 Desiccator with suitable desiccant. Anhydrous calcium sulfate or anhydrous calcium chloride have been found suitable.

4.2 Reagents.

4.2.1 Chloroform, U. S. P.

4.2.2 Hydrochloric acid solution. Hydrochloric acid solution containing 5 ml of hydrochloric acid, specific gravity 1.19 per 1,000 ml of solution.

METHOD 2610

4.2.3 Water solution of iodine.

5. PROCEDURE

5.1 Weight of original dry specimen. The specimen shall be placed in a weighing bottle and dried in an oven at a temperature of 221° to 230°1? (105° to 110°C), cooled in a desiccator, and weighed to the nearest 0.001 g. This is the "Weight of original dry specimen", and in the calculation of results is indicated as "O".

5.2 Weight of acid desized specimen. The dried specimen from 5.1 shall be extracted with chloroform for a minimum of 20 extractions in Soxhlet extractor. The extracted specimen shall then be immersed in approximately 300 ml of the solution of 0.5 percent hydrochloric acid by volume and squeezed until wet-out. The solution shall then be heated to boiling and boiled for 30 minutes with constant agitation. The specimen shall then be rinsed free of acid by squeezing in warm distilled water. The specimen shall be spot tested with iodine solution for the presence of starch. If the starch is not completely removed, the acid treatment shall be retested until the iodine test is negative. The specimen shall then be dried to a constant weight as described in 5.1, and weighed to the nearest 0.001 g. This is the "Weight of dry desized specimen", and in the calculation of results is indicated as "S".

5.3 Calculation of results.

5.3.1 The acid-hydrolyzable material shall be based upon the dry weight of the specimen and shall be calculated as follows:

$$\text{Acid-hydrolyzable material in specimen, dry basis, percent} = \frac{O-S}{O} \times 100$$

Where:

O = weight of original dry specimen, g (see 5.1)

S = weight of dry desized specimen, g (see 5.2)

6. REPORT

6.1 The acid-hydrolyzable material of the sample unit shall be the average of the results obtained from the specimens tested and shall be reported to the nearest 0.1 percent.

6.2 The individual values used to calculate the average shall also be reported.

NONFIBROUS MATERIALS IN COTTON, ENZYME METHOD

1. SCOPE

1.1 This method is intended for determining, in cotton or cellulosic mixture yarns or cloths, the amount of sizing, finishing, and other nonfibrous materials, such as oils, fats, waxes, minerals, and other materials which will be removed or determined by chloroform and/or water extraction, hydrolyzed by enzyme action, or remain as inorganic material after exposure to high temperatures. Although this method is intended for the determination of nonfibrous materials in cellulosic textiles, it may be used for determining the extractable and nonfibrous materials content of certain non-cellulosic textiles, as specified in the applicable end item specification or procurement document.

1.2 This method is not applicable to the determination of the amount of permanent types of finishes, such as urea condensates, melamine condensates, and substantive or organic finished, or to finishes that are volatile at 230°F (110°C).

2. TEST SPECIMEN

2.1 The specimen shall be approximately 10 g of the material undergoing test. Care should be taken in the preparation and subsequent handling of the specimen, so that loss of material will not occur during test. If the material undergoing test is woven or knitted cloth, the specimen should be cut on the bias and have loose fibers and yarns removed.

2.1.1 When total ash is required, an additional 10 g specimen is required for evaluation.

3. NUMBER OF DETERMINATIONS

3.1 Unless otherwise specified in the procurement document, two specimens shall be tested from each sample unit.

4. APPARATUS AND REAGENTS

4.1 Apparatus.

4.1.1 Analytical balance. Analytical balance capable of weighing accurately to 0.001 g.

METHOD 2611

4.1.2 Weighing bottle with ground glass cover.

4.1.3 Soxhlet extraction apparatus.

4.1.4 Muffle furnace.

4.1.5 Stainless steel sieve, 80 to 100 mesh or equivalent.

4.1.6 Desiccator with suitable desiccant. Anhydrous calcium sulfate or anhydrous calcium chloride have been found suitable.

4.2 Reagents.

4.2.1 Chloroform, U.S.P.

4.2.2 Iodine solution. An approximate 0.01N stock solution of iodine (0.13 g of iodine and 2.6 g of KI in 100 ml of water) may be prepared, and a portion of this diluted to a pale yellow color (about 0.001N) each time a test for starch is made.

4.2.3 Amylolytic and proteolytic enzyme mixture (see 7.1).

4.2.4 Millon's reagent. Millon's reagent shall be prepared by adding 25 g (17.6 ml) concentrated nitric acid (sp. gr. 1.42) to 25 g (1.84 ml) of mercury under a hood. Upon completion of the reaction, the solution shall be diluted by adding in equal volumes of distilled water.

5. PROCEDURE

5.1 Weight of dry specimen. The specimen shall be placed in a weighing bottle and dried in an oven at a temperature of 221° to 230°F (105° to 110°C), cooled in a desiccator, and weighed to the nearest 0.001 g. This is the "Weight of the dry specimen", and in the calculation of results is indicated as "O".

5.2 Chloroform-soluble material. The dried specimen from 5.1 shall be extracted with chloroform for a minimum of 20 extractions in Soxhlet extractor. If the weight of the chloroform-extractable matter is required, the extract shall be dried to constant weight in a tared container at a temperature of 174° to 178°F (79° to 81°C), cooled in a desiccator, and weighed to the nearest 0.001 g. This is the "Weight of chloroform-soluble material", and in the calculation of results is indicated as "C".

5.3 Water-soluble material. The specimen from 5.2 shall be placed in a Soxhlet extractor with distilled water and subjected to a minimum of 10 extractions. If the weight of the material is required, the extract shall be dried to constant weight in a tared container at a temperature of 212° to 215°F (100° to 102°C), cooled in a desiccator, and weighed to the nearest 0.001 g. This is the "Weight of the water soluble material", and in the calculation of results is indicated as "W". Chloroform and water extraction must be performed in determining starch and protein content. However, the determination for weight of extract, and calculations involved may be omitted when the exact amounts of water and chloroform-soluble material are not required.

5.4 Weight of desized specimen. The specimen from 5.3 shall then be immersed in a suitable aqueous enzyme solution containing both amylolytic and proteolytic components at the concentrations, liquid to fabric ratio, temperature, and length of time required to remove the finish as recommended by the manufacturer of the enzymes. The specimen shall be removed from the enzyme solution on a sieve, squeezed and rinsed to remove the enzyme solution. This shall be done by alternately squeezing and rinsing the specimen in a minimum of 12 successive baths of distilled water at 154° to 165° F (68° to 74°C). After rinsing, the specimen shall be spot-tested for the presence of starch with the iodine solution and for protein with Millon's reagent. The presence of starch is indicated by a blue coloration and the presence of protein by a red coloration. If either test is positive, repeat the enzyme treatment with the required rinsing until the spot-tests are negative. If additional treatments are required, the specimen shall be thoroughly rinsed before repeating the enzyme treatment. After the enzyme solutions have been completely removed from the specimen, the specimen shall be dried to constant weight (± 0.001 g) as described in 5.2. This is the "Weight of the desized specimen", and in the calculation of results is indicated as "S".

5.5 Residual ash. The desized specimen from 5.4 shall be ashed to constant weight at a temperature of 1112° to 1202°F (600° to 650°C) in a tared porcelain crucible employing a muffle furnace. After ashing, the ashed specimen and the crucible shall be placed in a desiccator, cooled, then removed and weighed immediately to the nearest 0.001 g. The weight of the tared crucible shall be subtracted from the total weight to give the "Weight of residual ash", which in the calculation of results is indicated as "R".

5.6 Total ash (inorganic material). The specimen from 5.1 shall be ashed to constant weight at a temperature of 1112° to 1202°F (600° to 650°C) in a tared porcelain crucible employing a muffle furnace. After ashing, the specimen shall be cooled in a desiccator and weighed to the nearest 0.001 g. This is the "Weight of the total ash", and in the calculation of results is indicated as "A".

METHOD 2611

5.7 Calculation of results.

5.7.1 The results shall be based on the weight of the dry specimens and shall be calculated to the nearest 0.1 percent using the following formulas:

Chloroform-soluble material only	$\frac{C}{O} \times 100$
Chloroform-soluble and water-soluble material only	$\frac{C + W}{O} \times 100$
Water-soluble material	$\frac{W}{O} \times 100$
Starch and protein content excluding chloroform-soluble and water-soluble material	$\frac{O - S - W - C}{O} \times 100$
Starch and protein content including chloroform-soluble and water-soluble material	$\frac{O - S}{O} \times 100$
Starch and protein content including chloroform-soluble material	$\frac{O - S - W}{O} \times 100$
Starch and protein content including water-soluble material	$\frac{O - S - C}{O} \times 100$
Residual ash only	$\frac{R}{O} \times 100$
Total ash only	$\frac{A}{O} \times 100$
Total sizing, finishing, and other non-fibrous material content	$\frac{O - S + R}{O} \times 100$

Where: O = Weight of original dry specimen, g (5.1).
 C = Weight of chloroform-soluble material, g (5.2).
 W = Weight of water-soluble material, g (5.3).
 S = Weight of desized specimen, g (5.4).
 R = Weight of residual ash, g (5.5).
 A = Weight of total ash, g (5.6).

6. REPORT

6.1 The chloroform-soluble material, water-soluble material, starch and protein content, total ash, residual ash, and total sizing, finishing, and other nonfibrous material of the sample unit shall be the average of the results obtained from the specimens tested, and shall be reported to the nearest 0.1 percent.

7. NOTES

7.1 The proteolytic and amylolytic enzymes used for removal of starch and protein compounds can be obtained from most chemical supply houses, including the following:

Wallerstein Company
125 Lake Avenue
Staten Island, NY 10303

Rohm and Haas Company
Independence Mall West
Philadelphia, PA 19105

NONFIBROUS MATERIALS IN LINEN TEXTILES

1. SCOPE

1.1 This method is intended for determining the nonfibrous materials added by the manufacturer and natural nonfibrous constituents in linen textiles.

2. TEST SPECIMEN

2.1 The specimen shall be approximately 10 g of material. Care should be taken in the preparation and subsequent handling of the specimen, so that loos of material will not occur during test. If the material under-going test is woven or knitted cloth, the specimen should be cut on the bias and have loose fibers and yarns removed.

3. NUMBER OF DETERMINATIONS

3.1 Unless otherwise specified in the procurement document, two specimens shall be tested from each sample unit.

4. APPARATUS AND REAGENTS

4.1 Apparatus.

4.1.1 Analytical balance. Analytical balance capable of weighing accurately to ± 0.001 g.

4.1.2 Weighing bottle with ground glass cover.

4.1.3 Reflux condenser.

4.1.4 Desiccator with suitable desiccant. Anhydrous calcium sulfate or anhydrous calcium chloride have been found suitable.

4.1.5 Stainless steel sieve, 80 to 100 mesh or equivalent.

4.2 Reagents.

4.2.1 Sodium hydroxide, 2 percent aqueous solution, by weight.

4.2.2 Acetic acid, 1 percent solution, by volume.

METHOD 2620

5. PROCEDURE

5.1 Weight of dry specimen. The specimen shall be placed in a weighing bottle and dried in an oven at a temperature of 221° to 230°F (105° to 110°C), cooled in a desiccator, and weighed to the nearest 0.001 g. This is the "Weight of original dry specimen", and in the calculation of results is indicated as "O".

5.2 Weight of extracted specimen. The specimen from 5.2 shall then be refluxed for 1 hour in a boiling 2 percent aqueous solution of sodium hydroxide. The specimen shall then be rinsed in warm water and then in a 1 percent aqueous solution of acetic acid followed with several rinses in water to remove the acetic acid using the sieve to collect any loose fibers. The residue shall then be dried to constant weight and weighed to the nearest 0.001 g. This is the "Weight of the extracted specimen", and in the calculation of results is indicated as "S".

5.3 Calculation of results.

5.3.1 The nonfibrous material shall be based upon the dry weight of the specimen and shall be calculated as follows:

$$\text{Nonfibrous material in specimen, dry basis, percent} = \frac{O-S}{O} \times 100$$

Where:

O = weight of original dry specimen, g (see 5.1)
S = weight of dry extracted specimen, g (see 5.2)

6. REPORT

6.1 The nonfibrous material in the sample unit shall be the average of the results obtained from the specimens tested and shall be reported to the nearest 0.5 percent.

6.2 The individual values used to calculate the average shall also be reported.

WOOL FIBER DAMAGE, ALKALI VOLUBILITY METHOD

1. SCOPE

1.1 This method is intended for determining the alkali volubility and the change in alkali volubility of wool which has been subjected to chemical treatment.

2. TEST SPECIMEN

2.1 The specimen shall be 1.0 ± 0.1 g of the material.

3. NUMBER OF DETERMINATIONS

3.1 Unless otherwise specified in the procurement document, four specimens shall be tested from each sample unit.

4. APPARATUS AND REAGENT

4.1 Apparatus.

4.1.1 Glass tubes. 125 to 150 ml capacity, with stoppers.

4.1.2 Constant temperature bath. Temperature maintained at $149^{\circ} \pm 2^{\circ}\text{F}$ ($65^{\circ} \pm 1^{\circ}\text{C}$).

4.1.3 Analytical balance. Analytical balance capable of weighing accurately to ± 0.001 g.

4.1.4 Weighing bottles.

4.1.5 Air oven. Circulating air oven thermostatically controlled, capable of maintaining a temperature between 221° to 230°F (105° to 110°C).

4.1.6 Sieves. Approximately 1-3/4 inches (44 mm) in diameter, with 100-mesh copper screening.

4.1.7 Desiccator with suitable desiccant. Anhydrous calcium sulfate or anhydrous calcium chloride have been found suitable.

4.1.8 Pair of tongs.

4.2 Reagent.

METHOD 2800

4.2.1 Sodium hydroxide solution. (0.1N)

5. PROCEDURE

5.1 If substantial quantities of grease, soap, or other extractable are present in the material, as may be the case in wools where the chemical treatment is applied at intermediate stages of manufacture (raw stock, top, or yarn), a preliminary extraction with an appropriate solvent shall be made.

5.2 Weight of dry specimen. The specimen shall be placed in a weighing bottle and dried in an oven at a temperature of 221° to 230°F (105° to 110°C), cooled in a desiccator, and weighed. The heating, cooling, and weighing cycle shall be repeated until the weight is constant within ± 0.003 g. This is the "Weight of the dry specimen", and in the calculation of results is indicated as "O".

5.3 A loosely stoppered test tube containing 100 ml of sodium hydroxide solution shall be placed in a constant temperature water bath and maintained at 149° ± 2°F (65° ± 1°C). The specimen from 5.2 shall be immersed in the tube of alkali solution, stirred once as soon as it is placed in the tube, and again 10 minutes later to insure complete wetting out.

5.4 Weight of alkali-treated specimen. After a total period of 1 hour from the time of immersion of the specimen in the alkali solution, the tube shall be removed from the water bath and its contents poured as rapidly as possible through a sieve. The tube shall then be rinsed twice with water to remove any adhering particles which shall then be deposited on the sieve. The specimen on the sieve shall be rinsed for 5 minutes by means of a stream of running tap water, approximately 3,000 ml per minute. The sieve shall then be placed on blotting paper to absorb the excess water. The specimen shall be returned to its weighing bottle, placed in the oven, and dried to constant weight as described in 5.2. This is the "Weight of the alkali-treated specimen", and in the calculation of results is indicated as "A".

5.5 The same tests shall be conducted on treated and untreated specimens for the purpose of comparison in determining the change in alkali volubility of the treated material.

5.6 Calculation of results.

5.6.1 The alkali volubility of the treated and the untreated specimens shall be calculated as follows:

$$\text{Alkali volubility, percent} = \frac{O-A}{O} \times 100$$

Where:

O = weight of dry specimen, g (see 5.2)

A = weight of alkali-treated specimen, g (see 5.4)

5.6.1.1 When testing blends of cotton and wool, an adjustment shall be made in the above formula so that the alkali volubility value shall be based on the weight of the wool alone.

5.6.1.2 The change in alkali volubility of wool which has been subjected to a chemical treatment shall be calculated as follows:

Change in alkali volubility, percent = T-U

Where:

T = percent alkali volubility of treated wool

U = percent alkali volubility of untreated wool

6. REPORT

6.1 The alkali volubility of the sample unit shall be the average of the results obtained from the specimens tested, and shall be reported to the nearest 0.1 percent.

6.2 The change in alkali volubility of the sample unit shall be the average of the results obtained from the specimens tested, and shall be reported to the nearest 0.1 percent.

6.3 The individual values used to calculate the average shall also be reported.

ACIDITY (pH) OF TEXTILES, COLORIMETRIC METHOD

1. SCOPE

1.1 This method is intended for determining the pH value of the water extract from textile materials. This procedure is limited in accuracy but may be used to determine the pH value of materials that are easily wetted. In case of a dispute involving the results obtained by this method, Method 2811 shall be used instead.

2. TEST SPECIMEN

2.1 The specimen shall be 10.0 ± 0.1 g of the material to be tested and shall be cut up into 1/8 to 1/4 inch (3 to 6 mm) pieces.

3. NUMBER OF DETERMINATIONS

3.1 Unless otherwise specified in the procurement document, two specimens shall be tested from each sample unit.

4. APPARATUS AND REAGENTS

4.1 Apparatus.

4.1.1 Balance. Balance capable of weighing accurately to ± 0.01 g.

4.1.2 Erlenmeyer flask. 500 ml with a joint to fit the condenser and a glass stopper.

4.1.3 Reflux condenser.

4.1.4 Calorimetric pH comparator with standard tubes.

4.1.5 Color comparison standards.

4.2 Reagents.

4.2.1 Distilled water. Distilled water having a pH of 6.2 to 7.0, prepared immediately before use by boiling for about 10 minutes and cooling to room temperature.

4.2.2 Potassium acid tartrate. Saturated solution pH 3.57.

METHOD 2810

4.2.3 Sodium borate solution. Buffered to a pH of 10.00.

4.2.4 Indicators as follows:

4.2.4.1 Universal indicator.

4.2.4.2 Meta cresol purple. Having a pH of 1.2 to 2.8.

4.2.4.3 Thymol blue. Having a pH of 1.2 to 2.8.

4.2.4.4 Bromophenol blue. Having a pH of 2.0 to 4.6.

4.2.4.5 Methyl red. Having a pH of 4.4 to 6.0.

4.2.4.6 Bromocresol purple. Having a pH of 5.2 to 6.8.

4.2.4.7 Bromothymol blue. Having a pH of 6.0 to 7.6.

4.2.4.8 Cresol red. Having a pH of 7.2 to 8.8.

4.2.4.9 Thymol blue. Having a pH of 8.0 to 9.6.

4.2.4.10 Thymolphthalein. Having a pH of 9.3 to 10.5.

4.2.4.11 Alizarine yellow R. Having a pH of 10.1 to 12.0.

5. PROCEDURE

5.1 Place the specimen to be tested in the 500 ml flask and add 200 ml of water and boil for 30 minutes under the reflux condenser. Remove and stopper the flask, allow the extract to cool to room temperature.

5.2 Ten ml of the solution shall be transferred to a calorimeter comparison tube, 0.5 ml of the universal indicator added, and well shaken. The color of the solution shall be compared with the color comparison standards to obtain the pH range of the solution.

5.3 An indicator solution of the proper range shall be selected, 0.5 ml added to a fresh 10 ml portion of the solution to be tested and well shaken. The color of the solution shall be matched with the standard color comparator.

6. REPORT

6.1 The pH of the sample unit shall be the average of the results obtained from the specimens tested and shall be reported to the nearest 0.2 pH.

6.2 The individual values used to calculate the average shall also be reported.

pH OF TEXTILES, ELECTROMETRIC METHOD

1. SCOPE

1.1 This method is intended for the determination of the pH, acidity or alkalinity of aqueous solutions extracted from textiles (fibers, yarns or fabric samples). This method is applicable to either finished or unfinished textiles.

2. TEST SPECIMEN

2.1 The specimen to be tested shall be 10.0 ± 0.25 g that has been cut up into 1/8 to 1/4 inch (3 to 6 mm) pieces.

3. NUMBER OF DETERMINATIONS

3.1 Unless otherwise specified in the procurement document, two specimens will be tested from each sample unit.

4. APPARATUS AND REAGENTS

4.1 Apparatus.

4.1.1 Balance. Balance capable of weighing accurately to ± 0.01 g.

4.1.2 pH meter. The meter shall include a glass electrode and a saturated calomel reference electrode (see 7.1 and 7.2).

4.1.2.1 Accuracy of pH meter. The pH meter shall be of a type that will read directly to an accuracy of 0.1 pH unit.

4.1.3 Erlenmeyer Flask. 500 ml.

4.1.4 1000 ml volumetric flask.

4.1.5 Drying tube (see 7.3).

4.2 Reagents (see 7.4 and 7.5).

4.2.1 Water (see 7.6). Distilled water that is to be used to make up the standardizing solutions and to be used for the extraction of the test specimen shall be boiled for 30 minutes. The water shall be boiled in a container that can be sealed while cooling to prevent contamination with carbon dioxide (see 7.7).

METHOD 2811

4.2.2 Standard Hydrochloric Acid Solution. (0.1M, pH = 1.10 at 25°C). Dilute 50 ml of hydrochloric acid, 36.5 percent, ACS reagent grade to 500 ml with distilled water and standardize to 0.10M, (see 7.8).

4.2.3 Standard Tartrate Solution. (saturated near 25°C, pH = 3.56 at 25°C). Shake vigorously an excess of potassium hydrogen tartrate ($\text{KHC}_4\text{H}_4\text{O}_6$) analytical grade with 100 to 300 ml of water in a glass stoppered flask. Filter, if necessary, to remove suspended salt. Add about 0.1 g of thymol as a preservative.

4.2.4 Standard Phthalate Solution. (0.05M, pH = 4.01 at 25°C). Dissolve in water 10.21 g of potassium hydrogen phthalate ($\text{KHC}_8\text{H}_4\text{O}_4$), analytical grade previously dried at 230°F (110°C) for 1 hour, dilute to 1 liter.

4.2.5 Standard Phosphate Solution. (0.025M, pH = 6.86 at 25°C). Dissolve 3.40 g of potassium dihydrogen phosphate (KH_2PO_4) and 3.55 g of anhydrous disodium hydrogen phosphate (Na_2HPO_4) in water and dilute to 1 liter. The two phosphates shall have been dried at 230°F (110°C) for 1 hour before use.

4.2.6 Standard Borax Solution. (0.01M, pH = 9.18 at 25°C). Dissolve 3.81 g of sodium tetraborate decahydrate ($\text{Na}_2\text{B}_4\text{O}_7 \cdot 10 \text{H}_2\text{O}$), analytical grade in water and dilute to 1 liter.

4.2.7 Standard Alkaline Phosphate Solution. (0.01M, pH = 11.72 at 25°C). Dissolve 1.42 g of anhydrous disodium hydrogen phosphate (Na_2HPO_4) in 100 ml of 0.1M, carbonate-free, solution of sodium hydroxide and dilute to 1 liter with water.

4.2.7.1 Sodium hydroxide. (0.1M, carbonate-free pH = 12.8 at 25°C). Dissolve 40.01 g sodium hydroxide (NaOH) pellets ACS reagent grade in 1000 ml of water. This solution shall be prepared long before using to allow time for any carbonates present to precipitate out of solution. Pipet 100 ml of this solution to a 1 liter volumetric flask and dilute to volume. Care should be taken not to disturb the carbonate precipitate at the bottom of the flask.

4.2.8 Sodium hydroxide. 0.1N Volumetric Standard Solution.

4.2.9 Phenolphthalein Solution. 1 percent Volumetric, Indicator.

4.3 Soda lime.

5. PROCEDURE

5.1 Place the specimen (2.1) to be tested in a 500 ml Erlenmeyer flask and then pour 200 ml of boiling water over the specimen. Immediately close the flask by inserting a stopper equipped with a drying tube containing soda lime. Allow to cool to room temperature for one hour with occasional swirling. If the solution has not reached room temperature in one hour, the flask may be adjusted to room temperature under flowing water.

5.2 Allow the pH meter to warm up thoroughly and bring to electrical balance in accordance with the manufacturer's instructions. The glass and calomel electrodes shall be washed three times with distilled water and dried gently with clean absorbent tissue. The temperature of the test solution shall be noted and the temperature dial of the meter adjusted to the proper setting.

5.3 If the anticipated pH of the test solution is less than 9.2, two standard solutions shall be selected one above and the one below this pH. These standards shall be warmed or cooled as necessary to match the temperature of the unknown within 2°F (1°C). A number of readings are made of the first standard solution until the meter remains in balance within ± 0.05 pH units for two successive portions.

5.4 The electrodes shall be washed three times with distilled water and immersed in the second standard buffer solution. The meter is adjusted to the new balance point and the pH value read from the meter. Additional portions of the second buffer solution are used until successive readings are in close agreement. The instrument shall be judged to be operating satisfactorily if the readings agree with the assigned value of the second standard buffer solution within 0.1 pH unit.

5.5 Wash the electrodes and sample container with distilled water after the meter has been standardized with the second standard pH solution. Immerse the electrodes in sufficient sample solution decanted from the 500 ml flask and take the pH reading promptly. Three portions of the solution shall be tested and two of the three readings must agree within 0.1 pH unit. When two readings do not agree within 0.1 pH unit, the meter shall be restandardized.

6. REPORT

6.1 The pH of each sample shall be reported as the average for the specimens tested and shall be reported to the nearest 0.1 pH.

7. NOTES

7.1 pH meters of the type required in this method may be purchased from Beckman Instruments, Inc., 2500-TR Harbor Blvd., Fullerton, CA 92632; Leeds and Northrup Co., 4901 Stenton Avenue, Philadelphia, PA 19144; and National Technical Laboratories, South Pasadena, CA 91030.

7.2 If the expected pH is 10 or higher, the high alkalinity type glass electrode shall be used.

7.3 Drying tube with overflow cup suitable for this method may be purchased from Ace Glass Incorporated, P.O. Box 688, Vineland, NJ 08360.

METHOD 2811

7.4 Packets containing the required amount to make up standard solutions may be purchased from laboratory chemical supply houses. With these packets it is only necessary to dissolve and dilute to 1 liter.

7.5 The stored standard solution shall not be older than 3 months, and should be stored in chemical resistant glass or polyethylene closed containers.

7.6 Wherever water is mentioned throughout this method, it will be understood that previously boiled and cooled distilled (carbon dioxide free) water is intended.

7.7 In case of dispute, distilled water having a pH of not less than 6.2 nor more than 7.0 and maximum residue of 5 parts per million when evaporated to dryness shall be used. Test for the presence of alkaline Impurities by boiling two specimens of approximately 100 ml for 15 minutes. Stopper and cool to room temperature. Wash the electrodes properly with water. Measure the pH of both specimens. If these readings are not between 6.2 and 7.0 re-distill the water from a solution containing 1 g potassium permanganate and 4 g of sodium hydroxide per liter to remove acid or organic material, or from a dilute solution of sulfuric acid to remove any volatile alkalinity.

7.8 The standard hydrochloric solution shall be standardized using 0.1N sodium hydroxide solution. A 10 ml portion of the hydrochloric acid solution is titrated to the end point with the standard sodium hydroxide using phenolphthalein as the indicator.

CHITIN CONTENT OF TEXTILES, AS A
MEASURE OF FUNGAL CONTAMINATION

1. SCOPE

1.1 This method is intended for determining the chitin content of textiles as a measure of low-level fungal infiltration (not visible at 36X magnification). Chitin is present in the cell walls of most fungi and thus the amount of chitin found may serve as an indicator of fungal contamination. Since this technique is designed to eliminate interference caused by the cellulosic matrix, it is possible to "concentrate" fungal growth from relatively large surface areas.

2. TEST SPECIMEN

2.1 The specimen shall consist of at least ten 2 inches by 2 inches (51 by 51 mm) pieces of the material under consideration. A control sample, utilizing the same area parameters as the test specimen shall be analyzed simultaneously.

3. NUMBER OF DETERMINATIONS

3.1 Unless otherwise specified in the procurement document, one specimen shall be tested from each sample unit.

4. APPARATUS AND REAGENTS

4.1 Apparatus.

4.1.1 Analytical balance.

4.1.2 Spectrophotometer or calorimeter (wavelength: 530 nm).

4.1.3 Hot plates (preferably 6-unit extraction heater pack).

4.1.4 Refluxing apparatus (preferably with ground-glass joints).

4.1.5 10 ml test tubes (graduated in 0.2 ml divisions with ground-glass stoppers).

4.1.6 Ultrasonic dismembrator.

4.2 Reagents.

METHOD 2820

4.2.1 10N sodium hydroxide.

4.2.2 1N sodium hydroxide.

4.2.3 12N hydrochloric acid.

4.2.4 2N hydrochloric acid.

4.2.5 0.5N hydrochloric acid.

4.2.6 Phenolphthalein solution (1 percent w/v).

4.2.7 2,4 - pentanedione (acetylacetone). This reagent must be redistilled every two weeks.

4.2.8 0.5N sodium carbonate.

4.2.9 Ethanol (absolute).

4.2.10 Ehrlich's reagent (1.336 g of p - dimethylaminobenzaldehyde is dissolved in 50 ml of ethanol followed by the addition of 50 ml of 12N hydrochloric acid). Store at 14°F (-10°C).

4.2.11 Glucosamine hydrochloride (1 ml = 8.6 mg glucosamine). Store frozen at 14°F (-10°C).

5. PROCEDURE

5.1 Preparation of specimen for testing.

5.1.1 Take at least ten 2 inches by 2 inches (51 by 51 mm) specimens of the material under consideration for each test sample (a material control must be analyzed simultaneously with each test sample).

5.1.2 Each square shall be placed in a dish that is at least 51 mm wide, 25 mm high and contains 20 to 25 ml of distilled water.

5.1.3 The surface of the square shall be treated with an ultrasonic dismembrator, such as a Branson high-intensity sonic processor, so as to dislodge the fungi from the material. This can be accomplished by thoroughly sweeping the fabric surface (at least three times) with the probe-like sonic converter. Discard the specimen and pour the liquid into a graduated 400-ml beaker. Repeat the ultrasonic technique for the remainder of the specimens, combining the dislodged material (in suspension) from each sonified specimen.

5.1.4 The 400-ml beaker containing the combined dislodged material shall be placed on a preheated hot plate and warmed until the fibers have agglomerated. The beaker shall be removed from the hot plate and the fibers allowed to settle. The volume shall be reduced (with a water aspirator) to approximately 40 ml, taking care that all the fibers are left behind. Two hundred milliliters of distilled water shall be added to the beaker and the fiber agglomeration step (described above) shall be repeated.

5.1.5 Forty ml of 12N hydrochloric acid shall be added to the 40 ml volume which shall be transferred to the refluxing apparatus, and refluxed for 6 hours. The contents shall be cooled and then transferred quantitatively through a Whatman 41H filter paper or equivalent into a 100-ml volumetric flask, and made up to volume.

5.2 Prepare a reagent blank.

5.2.1 Proceed as described in steps 5.4.1 through 5.4.4 except that 1 ml of distilled water shall be substituted for the 1.0 ml aliquot of test solution.

5.3 Prepare a calibration curve for the determination of chitin (see appendixes 1 and 2).

5.4 Determination of chitin.

5.4.1 A 1.0 ml aliquot shall be taken from the test solution and shall be pipetted into a 10 ml graduated test tube. One drop of phenolphthalein solution shall be added and the contents titrated with 10N NaOH until a pink color appears, and then back-titrated with 2N HCl until the pink color is discharged. The contents shall then be titrated with 1N NaOH until the pink color reappears, and then back-titrated with 0.5N HCl until the pink color is discharged. One milliliter of acetylacetone (dissolved in 50 ml of 0.5N sodium carbonate, prepared daily) shall then be added and the volume adjusted to 3.0 ml \pm 0.2 ml.

5.4.2 Each test tube, containing a condenser (an elongated test tube with one sealed end and filled with water will act as a condenser and as a loose stopper to prevent the loss of acetylacetone - condenser should not come in contact with contents of the test tube) shall be placed in a vigorously boiling water bath for 20 minutes, and then shall be cooled to room temperature. Ethanol (absolute) shall be added to each tube up to the 9.0 ml mark. One milliliter of Ehrlich's reagent shall then be added (by pipet) to each tube and the contents thoroughly mixed. Each test tube shall be placed in a 149°F (65°C) water bath for 10 minutes (to accelerate the liberation of carbon dioxide) and shall

METHOD 2820

then be cooled at room temperature. Ethanol (absolute) shall be added to each tube up to the 10 ml mark and the contents thoroughly mixed.

5.4.3 After 10 minutes a sufficient volume from each tube shall be transferred to a spectrophotometer cell and a reading obtained (color is stable for 3 hours). The spectrophotometer is set to 100 percent T with the reagent blank at a wavelength of 530 nm.

5.4.4 Obtain chitin content, in micrograms, from a working curve.

6. REPORT

6.1 Results shall be reported in micrograms of chitin per total fabric area (square centimeters) and shall be the difference between fabric blank and fabric sample X 100.

NOTE 1: Do not freeze glucosamine stock solution in volumetric flask (frozen solution will crack the flask).

NOTE 2: Ultrasonic dismembrator apparatus for use in this method may be purchased from Heat Systems-Ultrasonics, Inc., 38 East Mall, Plainview, L.I., NY 11803; VWR Scientific, P.O. BOX 2002, Rochester, NY 14603; Sonic Instruments Inc., 1018 Whitehead Road Ext., Trenton, NJ 08638.

NOTE 3: Ultrasonic dislodgement technique may be applied to the surface of any material that will retain its structural integrity.

APPENDIX 1

Preparation of Standard Solution

1. Chitin (glucosamine) Standard Stock Solution (1 ml. = 8.6 mg glucosamine). Dissolve 0.2589 g of glucosamine hydrochloride (equivalent to 0.2151 g) of glucosamine) to a 25 ml volumetric flask and dilute to the mark with distilled water. The concentration of this solution is 8.6 mg glucosamine per milliliter (stock solution may be kept indefinitely if stored frozen at 14°F (-10°C)).
2. A working solution may be prepared by pipetting 1.0 ml of the stock solution (ambient temperature) into a 100-ml volumetric flask diluting to the mark with distilled water. The concentration of this solution is (86.0 µg) glucosamine per milliliter.

METHOD 2820

APPENDIX 2

Preparation of Calibration Curve for the

Determination of Chitin (Glucosamine)

Pipet 0.1 (8.6 μg), 0.3 (25.8 μg), 0.5 (43 μg), 0.7 (60.2 μg) and 1.0 (86 μg) ml portions of the working solution (1 ml = 86.0 μg of glucosamine) into each of five 10.0 ml calibrated test tubes. A 6th 10.0 ml calibrated test tube shall contain 1.0 ml of distilled water and shall be carried as a blank. Proceed as described in step 5.4.1 (Determination of Chitin) beginning with "one drop of phenolphthalein solution shall be added" and concluding with step 5.4.3. Plot the values obtained (transmittance or absorbance) against micrograms of glucosamine per 10 ml of solution.

FED. TEST METHOD STD. NO. 191A

BECKER VALUE OF CORDAGE FIBER

1. SCOPE

1.1 This method is intended for evaluating the reflectance of abaca' (Manila "Hemp") fiber. It is applicable to raw fiber and to fiber from cordage.

2. TEST SPECIMEN

2.1 The test specimen shall be 24 g of a composite sample. When cordage is to be tested, the composite sample is prepared from 3 pieces, 12 inches (305 mm) long taken from a sample unit not less than 24 inches (610 mm) from each other. If rope, yarn or fiber is to be tested, take enough 12 inch (305 mm) lengths of the yarn or fiber, well distributed over the sample unit, to give a bundle 1 inch (25 mm) in diameter.

3. NUMBER OF DETERMINATIONS

3.1 Unless otherwise specified in the procurement document, four specimens shall be tested from each sample unit.

4. APPARATUS AND REAGENTS

4.1 Apparatus.

4.1.1 Reflectometer. A reflectometer shall be used whose geometrical and spectral characteristics conform to requirements for the measurement of Becker Value (see 7.4).

4.1.2 Reflectance standards. Reflectance standards of porcelain enamel which have been calibrated relative to magnesium oxide on a reflectometer known to conform to the geometric and spectral requirements of the definition for Becker Value (see 7.1) shall be used, (see 7.2). For accurate results, a reference standard must have the same spectral character and approximately the same Becker Value as that of the fiber being tested (see 7.3).

4.1.3 Cuvette. A specimen holder at least 5/8 inch (16 mm) deep with clear glass or optical grade plastic window in the bottom, large enough to receive the entire beam of the reflectometer. (See Appendix II)

METHOD 3810

4.1.4 Glass or plastic sheet. Glass or plastic sheet shall have the same thickness and spectral transmission as the bottom of the cuvette (see 4.1.3) and having the length and width of the reflectance standard (see 4.1.2) preferably cut from the same piece as the bottom window of the cuvette for calibrating equipment. The glass or plastic sheet is inserted between the standard and receptor in reflectometers sensitive to geometric and optical changes caused by its emission.

4.1.5 Soxhlet extraction apparatus.

4.2 Reagent.

4.2.1 Petroleum ether, technical.

50 PROCEDURE

5.1 Preparation of specimen.

5.1.1 Cut 3 pieces, each 12 inches (305 mm) in length, from a sample unit of rope to be tested. Open up a piece of rope and remove the paper marker if present. Untwist the strands and the yarns and make a cylindrical bundle including all the fibers in the cross-section of the rope. Compress the bundle as much as possible. It may be helpful to wrap the bundle in heavy kraft paper. The fibers must be cut to a length of 1/8 inch (3 mm) by slicing the bundle perpendicular to its long axis. Take care to avoid overheating and discoloration by too rapid cutting or a dull knife. Remove particles of paper, if used, from the cut fiber. Repeat this procedure for the 3 pieces cut from the sample unit.

5.1.2 Combine 8 g portions of the cut fibers from each of the 3 pieces of rope and mix thoroughly.

5.1.3 Place approximately 10 g of this composite sample in the thimble of the Soxhlet apparatus and extract by refluxing with petroleum ether for 2 hours. The solvent should be recycled approximately 15 times per hour.

5.1.4 Spread the extracted fibers out on a clean sheet of quantitative filter paper and allow them to dry completely at room temperature, preferably overnight.

5.2 Forming specimen in cuvette.

5.2.1 Carefully sprinkle the prepared specimen evenly into the cuvette from a spatula or folded sheet of paper. Do not handle the fibers with the fingers. When the window in the cuvette is evenly covered to a depth

of about 1/16 inch (2 mm) add additional fibers more rapidly to a depth of 1/2 inch (13 mm). Do not tamp or pack the fibers. The fiber surface against the window of the cuvette constitutes the specimen measurement.

5.3 Becker Value.

5.3.1 Turn on the reflectometer and allow the equipment to warm up for about 1/2 hour to bring the response to a steady rate.

5.3.2 Calibrate the reflectometer as follows: Cover the reflectance standard, (see 4.1.2), with the glass or plastic sheet where necessary, (see 4.1.4), and place the combination over the specimen aperture of the reflectometer. Read the instrument. If the indicated reflectance differs from that of the reflectance standard, adjust the apparatus to give the correct reading.

5.3.3 If a Gardner Photometric Unit is being used (see 7.4), place the back (fig. 3810B) on the filled cuvette and place the cuvette with the window on the center of the specimen aperture of the reflectometer; completely covering it. Read the reflectance. Rotate the cuvette through 90 degrees and read the reflectance again. A large difference noted in rotating the cuvette indicates that the fibers are not arranged at random and the cuvette should be emptied and refilled. If the two readings agree within 0.3 Becker Value, check the calibration as in 5.3.2. If the calibration has not changed more than 0.3 Becker Value during the measurements, the two readings are acceptable. Average them to obtain a single value for the specimen. If the calibration has changed more than 0.3 Becker Value, the reflectance measurements must be repeated.

5.3.4 If a Photovolt Reflection Meter is being used (see 7.4), place the filled cuvette carefully on the center of the specimen aperture completely covering it, and take a reading. Raise the cuvette 1/4 inch (6 mm) above the surface of the reflectometer and allow it to drop back into place to settle the fiber. Take a second reading. Repeat this procedure until successive readings agree. Check the calibration with the reflectance standard as before and if it has not changed more than 0.3 Becker Value during the measurements, take the last reflectance reading to be the value for the specimen. Repeat the measurements if the calibration has changed more than 0.3 Becker Value.

6. REPORT

6.1 The Becker Value for the sample unit is the average of the values for the specimens measured.

6.2 Each individual value used to calculate the average value shall also be reported.

METHOD 3810

6.3 Report the Becker Value to the nearest whole number.

7. NOTES

7.1 Becker Value. The reflectance of a specimen relative to magnesium oxide when illuminated at 45° by CIE Source A passing through a Wratten-75 filter and viewed perpendicularly by a receptor whose spectral response is equivalent to that of the CIE Standard observer.

7.2 Reference standards may be obtained from the National Bureau of Standards, Washington, DC 20234 and Photovolt Corporation, 1115 Broadway, New York, NY 10010.

7.3 A likely source of error in Becker Value measurements may be the departure of the spectral response of the reflectometer from the requirements of this method. A practical test for the conformance to spectral requirements may be made by adjusting the instrument to read correctly the Becker Value of a white reference standard then reading the value of a tan-colored standard that has nearly the same value as the fiber to be measured. The reading for the latter standard should be within a few tenths of the assigned values.

7.4 Gardner Photometric Unit when equipped with 45 degree exposure head and with Corning-403 and Wratten-75 filters between photocell and specimen is suitable. It may be obtained from Gardner Laboratories, Inc., Bethesda, MD 20014. The Photovolt Reflection Meter, when equipped with Corning 4010 and Corning 4308 filters, is suitable. It may be obtained from the Photovolt Corporation, 1115 Broadway, New York, NY 10010. The Martens (visual) photometer with Wratten 75 filter over the eyepiece and Standard Light Source A of the CIE may be used as in the past, but measurement with this equipment is less precise and more time consuming than with the photoelectric equipment. Any photometer conforming to the general requirements may be used provided it is shown to yield Becker Values in close agreement with the values obtained with the equipment referred to above. (See Appendix I).

APPENDIX I

PHOTOMETRIC EQUIPMENT

To qualify photometric equipment for the Becker Value test, test at least 25 fiber specimens representing a range of Becker Values from 35 to 55 with it and with one of the photometers referred to in 7.4, of the test method without disturbing the surface measured. Plot the results as shown in Figure 3810A and fit a straight line to the data using the method of least squares. In the Becker Value range from 35 to 55, the discrepancy between this "least squares line" and a unit slope line through the zero intercept should not exceed 0.5 Becker Value.

Suggestions for the operation of photoelectric reflectometers follow. Locate the instrument on a bench or table free from vibration. Turn on the current at least 1/2 hour before measurement to allow the instrument to warm up, with the resulting steadier readings and less frequent calibration. If the current is not steady the reflectometer should be operated with a special voltage regulator or from a storage battery. Check the zero setting before each use and reset if necessary. Cover the sample aperture completely so that no outside light can reach the photocell. Calibrate with the reflectance standard before and after measurements. Frequent rechecking of calibration is essential. Clean the optical system from time to time to remove dust and dirt and clean the filter before each use. If the component parts of the filter separate they should be recemented. Follow the instructions of the manufacturer of the reflectometer.

METHOD 3810

APPENDIX II

CUVETTE OR SPECIMEN HOLDER

A suitable cuvette for use with the Gardner Photometric Unit is shown in Figure 3810B. The surface measured is that of the fiber against the window in the bottom of the cell shown in cross-section in the upper part of "a". The fiber is held against the window by the back of the cell shown in "b". A cell for use with the Photovolt Reflection Meter may be made from a one-inch (25 mm) length of 35 mm (outside diameter) Pyrex glass tubing, 2 mm wall thickness. The window is made from ophthalmic crown glass, Code #8361 (Corning) or equivalent, 1.6 mm plus or minus 0.1 mm thick cemented to one end of the Pyrex tube. Clean cuvettes periodically with a detergent and water followed by rinsing with alcohol and ether and drying in a stream of air. After each use, blow out with air to remove all fibers and dust. Do not wipe with cloth or soft paper as this will generate static electrical charges, and result in non-random distribution of cut fibers, and cause incorrect reflectance values.

FED. TEST METHOD STD. NO. 191A

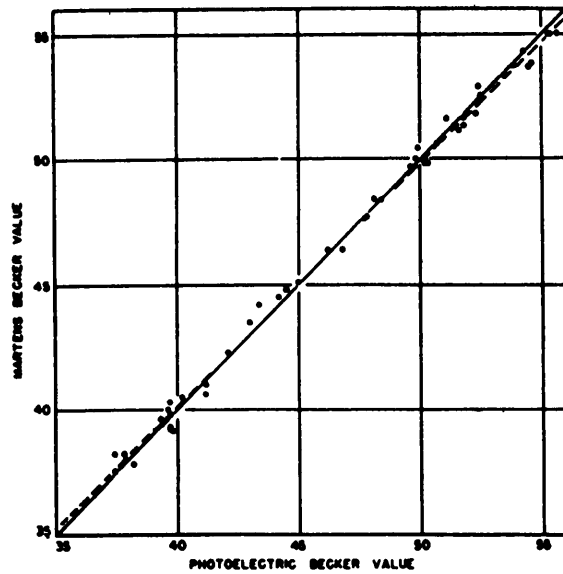
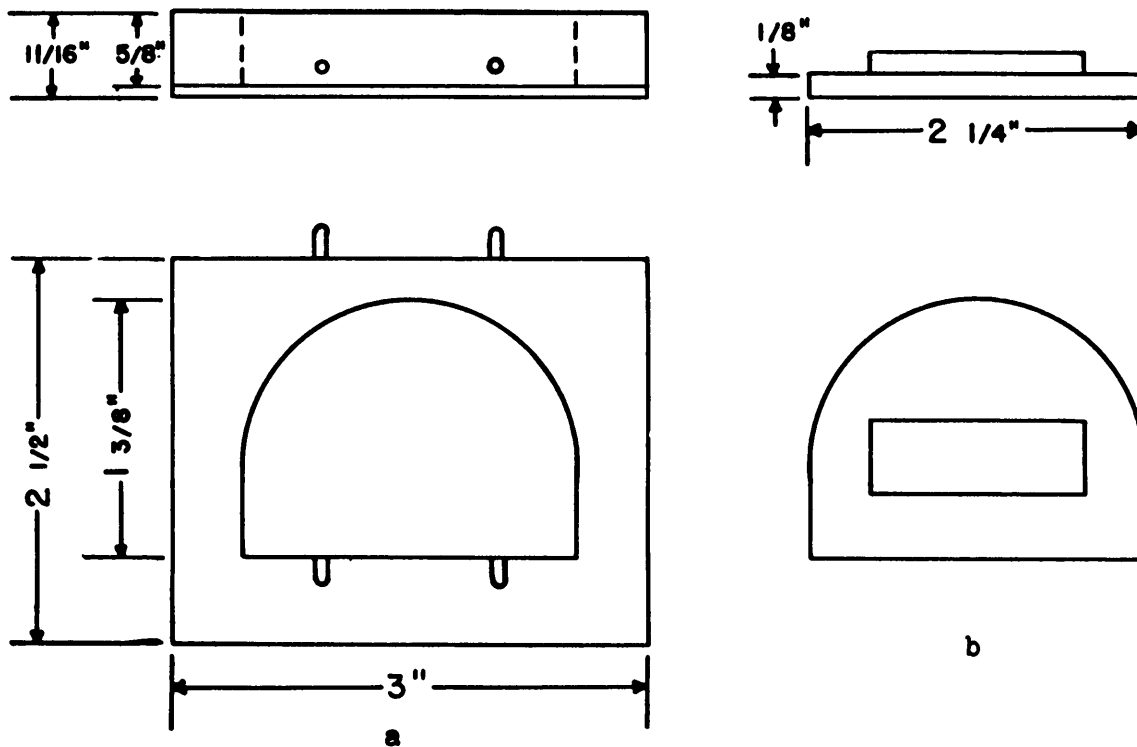

FIGURE 3810A Photoelectric Becker values plotted against visual values.

Broken line represents the least-square line.



- a. Body of cell.
b. Back of cell.

FIGURE 3810B - Cuvette used with Gardner photometric unit.

*The back is held in place by the tension of rubber bands which are looped over the protruding studs in "a" and contact back on the rectangular raised portion.

LENGTH-WEIGHT RELATION; THREAD; YARDS PER POUND (m/kg)

10 SCOPE

1.1 This method is intended for determining the length per pound (length per kg) of sewing thread taken from such packages as spools or cones.

2. TEST SPECIMEN

2.1 The specimen shall be a skein of thread. Unless otherwise specified in the procurement document, each skein of heavy thread shall contain not less than 30 yards (28 m); each skein of machine or basting thread shall contain not less than 120 yards (110 m).

3. NUMBER OF DETERMINATIONS

3.1 Unless otherwise specified in the procurement document, five specimens shall be tested from each sample unit.

4. APPARATUS

4.1 Reel. Reel, accurate to 0.1 percent, equipped with means for recording length, applying tension, and spreading the thread evenly on the reel.

4.2 Analytical balance. Analytical balance or a grain-yam scale, accurate to ± 0.25 percent.

5. PROCEDURE

5.1 Unless otherwise specified in the procurement document, the specimens tested shall be conditioned and tested under Standard Conditions in accordance with Section 4 of this Standard.

5.2 Preparation of skeins.

5.2.1 Threads wound on spools, cones or similar put-up. For threads wound on spools, cones, or similar put-up, the thread shall be drawn from the top of the package at a speed of 100 to 300 revolutions per minute of the reel. The thread shall be passed through the guides in such a way that the tension in the running yarn is sufficient to straighten it, but not high enough to cause serious stretching. If the reel has only one pigtail guide per skein, tension shall be applied by taking one full wrap around the guide. If the reel has two or more guides, the thread shall pass straight through the guides onto the reel, the angle of the guides supplying necessary tension.

METHOD 4010

5.2.2 Thread wound on parallel tubes, large flanged spools, large tubes or similar put-up. For threads on parallel tubes and large flanged spools, large tubes, certain warp wound bobbins or similar put-up, the thread shall be drawn from the side at a speed of 20 to 30 revolutions per minute of the reel. Judgement must be used in applying tension on threads having a small or large amount of twist.

5.3 The finishing end of the skein shall be tied to the starting end of the skein in such a reamer that the knot will not add additional length to the reel skein.

5.4 Weight of skein. The prepared skein shall be weighed, using an analytical balance or a grain-yarn scale, and the weight recorded.

5.5 Calculations. The yards per pound (m/kg) shall be calculated as follows:

$$\text{Yards per pound} = \frac{7000 \times \text{number of yards in specimen}}{\text{Weight of specimen in grains}}$$

OR

$$\text{Yards per pound} = \frac{453.6 \times \text{number of yards in specimen}}{\text{Weight of specimen in g}}$$

OR

$$\begin{aligned} & \text{m/kg} \\ \text{Meters per kilogram} &= \frac{\text{Number of m in specimen}}{\text{Weight of specimen in kg}} \end{aligned}$$

OR

$$\text{m/kg} = (\text{yds/lb}) \times 2.02$$

6. REPORT

6.1 The yards per-pound (m/kg) of a sample unit shall be the average of the specimens tested from the sample unit and shall be reported to the nearest yard (m).

6.2 Each individual value used to calculate the average shall also be reported.

METHOD 4021
July 20, 1978

YARN NUMBER (LINEAR DENSITY) OF YARN FROM PACKAGE

1. SCOPE

1.1 This method is intended for determining the yarn number (linear density) of yarn taken from such packages as cones, cops, bobbins, tubes, and similar put-up. It is applicable to single and plied yarns.

2. TEST SPECIMEN

2.1 The test specimen shall be a skein of yarn. The specimen size shall be as follows:

2.1.1 Indirect system of units (length-weight ratio).

2.1.1.1 Skein length for single yarns. Skein length for all singles yarns shall be 120 yards, (110 m).

2.1.1.2 Skein length for plied yarns. Skein length for plied yarns shall be as follows:

Plied Yarn Equivalent Singles Numbers

Cotton and Spun Rayon	Linen and wool cut	Worsted	Wool Run	Length to Reel for Test	
				<u>Yards</u>	<u>Meters</u>
20 and above	56 and above	30 and above	11 and above	60	55
3 to 20	8.4 to 56	4.5 to 30	1.6 to 11	24	22
Below 3	Below 8.4	Below 4.5	Below 1.6	12	11

Direct System of Units (Weight per Unit Length)

Filament yarns	Length to Reel for Test	
	<u>Yards</u>	<u>Meters</u>
Below 1.30 denier (14 tex)	300	275
130 to 650 denier (14 to 72 tex)	120	110
650 denier (72 tex) and above	15	14

METHOD 4021

3. NUMBER OF DETERMINATIONS

3.1 Unless otherwise specified in the procurement document, four specimens shall be tested from each sample unit.

4. APPARATUS AND METHOD CITED

4.1 Apparatus.

4.1.1 Yarn reel. Yarn reel accurate to ± 0.1 percent, equipped with means to record length, applying tension, and spreading the yarn evenly on the reel.

4.1.2 Analytical balance. Analytical balance or grain-yam scale, accurate to ± 0.25 percent.

4.2 Method cited.

4.2.1 Method 4054, Twist and Twist Contraction; Ply Yarns.

5. PROCEDURE

5.1 Unless otherwise specified in the procurement document, the specimens for testing shall be conditioned and tested under Standard Conditions in accordance with Section 4 of this Standard.

5.2 Preparation of skeins.

5.2.1 Yarn wound on cones, bobbins, cops or small flange spools or tubes. For yarn wound on cones, filling wound bobbins and cops, and small flange spools or tubes, the yarn shall be drawn from the top of the package at a speed of 100 to 300 revolutions per minute of the reel. The yarn shall be passed through the guides in such a way that the tension in the running yarn is sufficient to straighten it, but not high enough to cause serious stretching. If the reel has only one pigtail guide per skein, tension shall be applied by taking one full wrap around the guide. If the reel has two or more guides, the yarn shall pass straight through the guides onto the reel, the angle of the guides supplying the necessary tension.

5.2.2 Yarn wound on large flanged spools, large tubes or warp wound bobbins. For packages such as large flanged spools, large tubes, certain warp wound bobbins or similar put-up, the yarn shall be drawn from the side at a speed of 20 to 30 revolutions per minute of the reel. If the reel has two or more guides, the yarn shall pass straight through the guides onto the reel. Judgment must be used in applying tension on yarns having a small or large amount of twist.

METHOD 4021

5.3 The finishing end of the skein shall be tied to the starting end of the skein in such a manner that the knot will not add additional length to the reeled skein.

5.4 Weight of skein. The prepared skein shall be weighed using an analytical balance or grain-yam scale, and the weight recorded.

5.5 Calculations. The yarn number, using the weight and length of the skein, shall be calculated using the following formulas:

Indirect system:

$$\text{Yarn Number } N = \frac{L}{W} \times \frac{453.6}{Y} \quad (\text{or}) \quad N = \frac{L}{W_1} \times \frac{7000}{Y}$$

$$\text{Yarn Number } N_1 = \frac{L \times P}{(1-C/100)} \times \frac{453.6}{W \times Y} \quad (\text{or}) \quad N_1 = \frac{L \times P}{(1-C/100)}$$

Direct system - Denier:

$$\text{Denier } N = \frac{W \times 9840}{L} \quad (\text{or}) \quad \frac{W \times 9000}{L_1}$$

$$\text{Denier } N_1 = \frac{W \times 9840}{(1-C/100) L} \quad (\text{or}) \quad \frac{W \times 9000}{(1-C/100) L_1}$$

$$\begin{aligned} \text{Yarn number in tex units} &= \frac{310.034}{\text{woolen run number}} \\ &= \frac{590.541}{\text{cotton hank number}} \\ &= \frac{885.812}{\text{worsted hank number}} \\ &= \frac{1653.5}{\text{linen lea number}} \\ &= \frac{1653.5}{\text{wool cut number}} \\ &= \frac{\text{denier}}{9} \quad (\text{synthetics}) \end{aligned}$$

METHOD 4021

Where:

N = equivalent single yarn number of plied yarn or number of single yarn.
 N_1 = true single yarn number, i.e., single yarn number prior to plying.
 L = length of single or ply yarn in yards.
 L_1 = length of single or ply yarn in meters.
 W = weight of skein in grams.
 W_1 = weight of skein in grains.

453.6 grams in one pound.
 7000 grains in one pound.

P = number of plies in yarn.
 C = Twist contraction in plying, percent (see Method 4054).
 Y = yards of No. 1 yarn in one pound. The value of Y for indirect system is:

840 for cotton system (cotton, spun rayon)
 300 for linen and wool, "cut" system
 560 for worsted
 1600 for wool, "run" system

Constant for direct system:

9000 for denier, grams per 9000 meters
 9840 for denier, grams per 9840 yards

5.5.1 Yarn number. The yarn number of a specimen shall be based on its equivalent single yarn number. If the finished yarn is made up of plied components, the yarn number is expressed as a multiple of the single yarn number for the component yarns.

Examples:

Cotton, spun rayon and blends - A single yarn with an equivalent yarn number of 60 would be expressed as 60/1. A plied yarn composed of 3 single yarns of number 60 and whose equivalent single yarn number may be for example, 19 or 20 shall be expressed as 60/3.

Wool cut or run, worsted and linen - A single yarn with an equivalent yarn number of 60 would be expressed as 1/60. A plied yarn composed of 3 single yarns of number 60 and whose equivalent single yarn number may be, for example, 19 or 20 shall be expressed as 3/60.

Filament yarn - A plied yarn of 4 single yarns of 210 denier, 34 filament shall be expressed as 210/34/4 ply.

METHOD 4021

6. REPORT

6.1 The yarn number of the sample unit shall be the average of the specimens tested.

6.1.1 The yarn number in the indirect system shall be reported to the nearest 0.1 number for yarn numbers 0 to 12 inclusive, and to the nearest whole number for yarn numbers above 12.

6.1.2 Yarn numbers in the direct system shall be reported to the nearest whole number.

6.2 Each individual value used to calculate the average shall also be reported.

7. NOTES

7.1 Caution should be used when making plied yarn determinations because the amount of contraction due to twist will have an effect on the yarn number.

METHOD 4050
July 20, 1978

DIRECTION OF TWIST: YARN, THREAD, CORDAGE

1. SCOPE

1.1 This method is intended for determining the direction of twist of yarn, thread, and cordage.

2. TEST SPECIMEN

2.1 Unless otherwise specified in the procurement document, the specimen shall be any convenient length.

3. NUMBER OF DETERMINATIONS

3.1 Unless otherwise specified in the procurement document, three specimens shall be tested from each sample unit.

4. APPARATUS

4.1 No special apparatus is required for this method, but a magnifying glass and pick needle may be necessary for testing extremely fine yarns.

5. PROCEDURE

5.1 The specimen shall be held in a vertical position and the direction of the slope of the twist spirals observed.

6. REPORT

6.1 Direction of twist of specimen. The direction of the twist of each specimen shall be expressed as "S" twist if the spirals conform in direction of slope to the central portion of the letter "S"; and "Z" twist if the spirals conform in direction of slope to the central portion of the letter "Z" (see Figure 4050).

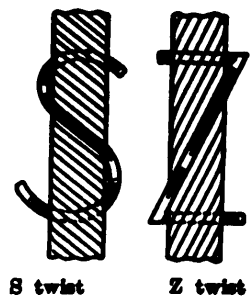

FIGURE 4050

TWIST IN SINGLE YARNS

1. SCOPE

1.1 This method is intended for determining the turns per inch (turns/cm) of single yarns by use of the untwist/twist method on a twist tester. This method is suitable for use on spun staple yarns where it is found difficult to determine zero twist by use of a needle as can be done in the case of wool or filament fibers.

2. TEST SPECIMEN

2.1 The specimen shall be at least a 12 inch (305 mm) length of the yarn taken as follows:

2.1.1 From package. Yarn from a tube, bobbin, spool, skein, cone, or ball shall be drawn from the side of the package and in such a manner that the twist will not be altered.

2.1.2 From cloth. Yarn shall be raveled from woven or knitted cloth, care being taken to avoid alteration in twist of the yarn. Where it is possible, at least three bobbin areas shall be included in the specimens prepared from the filling direction of the woven cloth.

3. NUMBER OF DETERMINATIONS

3.1 Unless otherwise specified in the procurement document, 20 specimens shall be tested from each sample unit.

4. APPARATUS

4.1 Twist counter. A twist counter consisting essentially of two clamps along the same horizontal axis. One clamp non-rotating but movable that can be held in position by tightening the thumb screw, the other clamp is fixed in position but capable of being rotated in either direction and provided with a dial or counter for recording the number of turns. The twist counter shall also be provided with the following:

4.1.1 Means for adjusting the distance between the clamps within a range of 0 to 10 inches (0 to 254 mm).

4.1.2 Means for mounting the specimen in the clamps under a known tension applicable through the non-rotating clamp.

METHOD 4052

4.1.3 When applicable, means for determining the extension produced by removal of twist to an accuracy of at least 0.1 inch (2.5 mm).

4.1.4 Means of applying a load of 1 g at the center of the specimen and means of measuring the deflection of the yarn at that point.

5. PROCEDURE

5.1 Unless otherwise specified in the procurement document, the specimens shall be conditioned and tested under standard conditions in accordance with section 4 of this standard.

5.2 Standard procedure.

5.2.1 The counter of the tester shall be set at the zero mark. One end of the specimen shall be secured in the free non-rotating clamp, having a tension device and the other end placed at a distance of approximately 10 inches (254 mm) in the open rotatable fixed clamp. Tension shall be applied to the specimen by pulling it under the applicable load specified below until the distance between the clamps is adjusted to 10 inches (254 mm). The rotatable clamp shall then be tightened securely and the position of the movable clamp fixed by tightening the thumb screw.

5.2.2 Tension for mounting specimen. Unless otherwise specified in the procurement document, the specimen shall be mounted under the following tension in grams:

$$\text{Cotton and spun yarn tension, g} = \frac{156}{\text{Yarn No., cotton system}}$$

$$\text{Wool and worsted yarn tension, g} = \frac{\text{weight of 100 yards (91.4 m) of yarn being tested.}}{100}$$

Filament yarn tension:

- 10 g for 75 denier (8.4 tex) of finer;
- 20 g for 75 denier (8.4 tex) to 150 denier (17 tex);
- 30 g for coarser than 150 denier (17 tex).

5.2.3 A one g load shall then be applied at the center of the specimen and its height at this point measured or otherwise indicated. The one g load shall be removed. Then the rotatable clamp shall be revolved in the direction which untwists the specimen, continuing the rotation in the same direction beyond the neutral point, thereby imparting a twist to the specimen which is opposite to the original direction.

METHOD 4052

5.2.4 When sufficient turns have been inserted to prevent slippage of the fiber, the one g load shall be reapplied at the center of the specimen and the twisting continued until the initial height or position of the one g load is obtained. When this point is reached, it is assumed that the same amount of twist has been reinserted as was initially in the specimen. The number of turns shown on the dial shall be recorded.

5.3 Alternate procedure.

5.3.1 The distance between the clamps shall be set at 10 inches (254 mm) and the counter of the tester set at the zero mark. The specimen shall be secured in the rotatable clamp and placed in the open fixed clamp while a tensioning load of one g is applied at the center of the specimen. The free end shall then be pulled through the open clamp in such manner that a deflection of 0.125 inch (3 mm) is obtained at the point of application. The fixed clamp shall be tightened securely and the tensioning load removed.

5.3.2 The rotatable clamp shall be revolved in the direction which untwists the specimen, continuing the rotation in the same direction beyond the neutral point, thereby imparting a twist to the specimen opposite to the original direction.

5.3.3 When sufficient turns have been inserted to prevent slippage of the fibers, the tensioning load shall be reapplied and twisting continued until the deflection of 0.125 inch (3 mm) is obtained again. When this point is reached, it is assumed that the same amount of twist is reinserted as was initially in the specimen. The number of twists on the dial shall be recorded.

6. REPORT

6.1 Twist of specimen. The total number of revolutions divided by 20 shall be the twist in turns per inch of the specimen. The turns per inch multiplied by 0.394 shall be the twist in turns per centimeter.

6.2 Twist per inch (/cm) of sample unit. The twist per inch (/cm) of the sample unit shall be the average of the results obtained from the specimens tested and shall be reported in turns per inch (/cm) to the nearest whole number.

6.3 Each individual value used to calculate the average shall also be reported.

TWIST AND TWIST CONTRACTION; PLY YARNS

1. SCOPE

1.1 This method is intended for determining the number of turns of twist per inch (/cm) of ply yarns and the twist contraction by untwisting on a twist tester.

2. TEST SPECIMENS

2.1 The specimen shall be at least a 12 inch (305 mm) length of yarn taken as follows:

2.1.1 From package. Yarn from a cop, bobbin, cone, tube, or similar put-up shall be drawn from the side of the package and in such a manner that the twist will not be altered.

2.1.2 From cloth. Yarn shall be ravened from woven or knitted cloth, care being taken to avoid alteration in twist of the yarn. Where it is possible, at least three bobbin areas shall be included in the specimens prepared from the filling direction of the woven cloth.

3. NUMBER OF DETERMINATIONS

3.1 Unless otherwise specified in the procurement document, 10 specimens shall be tested from each sample unit.

4. APPARATUS

4.1 Twist counter. Twist counter consisting essentially of two clamps along the same horizontal axis. One clamp non-rotating but movable that can be held in position by tightening the thumb screw, the other clamp is fixed in position but capable of being rotated in either direction and provided with a dial or counter for recording the number of turns. The twist counter shall also be provided with the following:

4.1.1 Means for adjusting the distance between the clamps within a range of 0 to 10 inches (0 to 254 mm).

4.1.2 Means for mounting the specimen in the clamps under a known tension applicable through the non-rotating clamp.

4.1.3 When applicable, means for determining the extension produced by removal of twist to an accuracy of at least 0.1 inch (2.5 mm).

METHOD 4054

4.1.4 Needle.

5. PROCEDURE

5.1 Unless otherwise specified in the procurement document, the specimens tested shall be conditioned and tested under standard conditions in accordance with Section 4 of this Standard.

5.2 Twist. The counter of the tester shall be set at the zero mark. One end of the specimen shall be secured in the free non-rotating clamp having the tension device. The other end shall be drawn through the open rotatable fixed clamp to a distance of 10 inches (254 mm) between the clamps and secured while the specimen is under the applicable required load (5.2.1). The movable clamp shall be allowed to remain free. The ply twist shall then be removed by revolving the clamp until the component strands are parallel and can be separated along the entire length by means of a needle. The total number of revolutions shall be recorded. It is the number of turns of ply twist in the 10-inch (254 mm) long specimen.

5.2.1 Tension for mounting specimen. Unless otherwise specified in the procurement document, the specimen shall be mounted under the following tension in g:

$$\text{Cotton and spun yarn tension, g} = \frac{156}{\text{Yarn No., Cotton system}}$$

$$\text{Wool and worsted yarn, tension, g} = \frac{\text{weight of 100 yards (91.4 m) of yarn being tested}}{\text{yarn being tested}}$$

$$\begin{aligned} \text{Filament yarn tension:} & \quad 10 \text{ g for 75 denier (8.4 tex) or finer} \\ & \quad 20 \text{ g for 75 denier (8.4 tex) to 150 denier (17 tex)} \\ & \quad 30 \text{ g for coarser than 150 denier (17 tex)} \end{aligned}$$

5.3 Twist contraction. The untwisted plies, 5.2, shall be maintained under the tension in the twist tester and their extended length shall be measured. The increase in length of the specimen due to the removal of twist is the twist contraction of the yarn. It may be read in inches (cm) or percent on a calibrated extension of the sliding jaw of the twist tester.

5.4 Calculations.

5.4.1 The twist per inch (/cm) of the specimen shall be the number of turns divided by 10. The turns per inch multiplied by 0.394 shall be the twist in turns per centimeter.

$$5.4.2 \text{ Twist contraction, percent} = \frac{\text{extended length of untwisted specimen} - 10}{\text{extended length of untwisted specimen}} \times 100$$

6. REPORT

6.1 The twist of the yarn from the sample unit shall be the average of the results obtained from the specimens tested and shall be reported to the nearest 0.5 turn per inch (0.1 turn/cm).

6.2 The contraction of the yarn from a sample unit shall be the average of the results obtained from the specimens tested and shall be reported to the nearest 0.1 percent.

6.3 Each individual value used to calculate the average shall also be reported.

STRENGTH AND ELONGATION, BREAKING; AND TENACITY;
OF THREAD AND YARN; SINGLE STRAND

1. SCOPE

1.1 This method is intended for determining the breaking strength, elongation, and tenacity of sewing thread and yarns. Single or ply threads and yarns may be tested by this method.

2. TEST SPECIMEN

2.1 The test specimen shall be of sufficient length to mount in the jaws of the apparatus. This distance between the pair of jaws of the apparatus (gage length) shall be 10 inches (254 mm) at the beginning of the test.

3. NUMBER OF DETERMINATIONS

3.1 Unless otherwise specified in the procurement document, 10 specimens shall be tested from each sample unit.

4. APPARATUS

4.1 The machine shall consist of three main parts:

- (a) straining mechanism;
- (b) clamps for holding specimen;
- (c) load and elongation recording mechanism.

4.1.1 Straining mechanism. A machine wherein the specimen is held between two clamps and strained by a uniform movement of the pulling clamp shall be used. Unless otherwise specified in the procurement document, the machine shall be adjusted so that the pulling clamp shall have a uniform speed of 12 ± 0.5 inches (305 ± 13 mm) per minute.

4.1.2 Clamps for holding specimen.

4.1.2.1 Natural fiber specimen. Unless otherwise specified in the procurement document, the machine shall have two clamps with two flat-grip type jaws on each clamp. The design of the two clamps shall be such that one gripping surface or jaw may be an integral part of the rigid frame of the clamp or be fastened to allow a slight vertical movement, while the other gripping surface or jaw shall be completely movable. Unless otherwise specified, the dimensions of the

METHOD 4100

immovable rear jaw of each clamp shall measure one inch parallel to the application of the load, and the dimension of the jaw perpendicular to this direction shall measure one inch (25 mm) or more. The face of the movable front jaw of each clamp shall measure one inch by one inch (25 by 25 mm). Each jaw face shall have a flat smooth gripping surface. All edges which might cause cutting action shall be rounded to a radius of not over 1/64 inch (0.4 mm). In cases where the specimen tends to slip when being tested, the jaws may be faced with rubber or other material to prevent slippage. Unless otherwise specified, the distance between the jaws (gage length) shall be 10 inches (254 mm) at the start of the test.

4.1.2.2 Synthetic fiber specimen. Thread clamps embodying the flat anvil and drum principle with side closing cam, known as Callaway or U. S. Rubber Clamps, shall be used. The gage length shall be 10 inches, (254 mm) measured from the bite between the drum and flat jaw of the upper clamp around the periphery of each drum, and to the bite between the drum and flat jaw in the bottom clamp.

4.1.3 Load and elongation mechanism(s). Calibrated dial, scale or chart to indicate applied load and elongation. Unless otherwise specified for load determination, the machine shall be adjusted or set so that the maximum load required to break the specimen will remain indicated on the calibrated dial, scale or chart of the autographic recording mechanism.

5. PROCEDURE

5.1 Unless otherwise specified in the procurement document, testing shall be performed on conditioned specimens and under standard conditions in accordance with Section 4 of this Standard. When wet breaking strength is required, it shall be specified in the applicable procurement document and the method of wetting the specimen shall also be specified.

5.2 Preparation of specimen.

5.2.1 Specimens taken from cop, bobbin, cone, tube, or similar put-up shall be drawn from the side of the package and in such a reamer that the twist will not be altered.

5.2.2 If the sample has been previously wound in skein form, the skein shall be mounted on an umbrella reel from which a single end may be drawn.

5.2.3 When the yarn is taken from a woven or knitted cloth, the yarns shall be raveled from cut strips in such a manner that the yarn is not stretched and the twist is not altered.

5.3 Preliminary adjustments.

5.3.1 Prior to testing the operator shall verify that the apparatus has been calibrated in accordance with the procedure required for the make and model being used.

METHOD 4100

5.3.2 If an autographic mechanism is to be used, it shall be determined by a trial run of the apparatus that it is operating properly. Be sure that the recording pen has an ample supply of ink to avoid depletion of the supply during test.

5.3.3 Check distance between jaws (gage length) and speed of machine to insure they are as required.

5.3.4 Check alignment of jaws in each clamp and also the alignment of clamps with respect to each other.

5.4 Testing.

5.4.1 Initial load. When it is required to determine the elongation of a specimen, an initial load shall be applied to the specimen prior to tightening the second clamp. Unless otherwise specified, in the procurement document, the initial load in g shall be 0.25 g per tex unit (see 7.1).

5.4.2 Breaking strength. The specimen shall be placed in the jaws of the clamps, exercising care to insure that the twist of the specimen is not altered. Force is applied to break the specimen and this force read from the chart, dial or scale shall be recorded.

5.4.3 Elongation. The elongation of the specimen at any given load shall be determined when the breaking strength is measured for the same specimen. The initial length and, therefore, the measured elongation depend upon the load applied when placing the specimen in the clamps. Place one end of the specimen in a clamp and tighten sufficiently to prevent slipping. Apply the required initial load (see 5.4.1) to the other end of the specimen in such a manner that it does not interfere with tightening of the second clamp sufficiently to prevent slipping. The elongation shall be determined from the scale or chart of the autographic recording mechanism.

5.5 Tenacity. The tenacity of the specimen shall be calculated using the breaking strength and equivalent denier size.

5.6 If a specimen slips between the jaws, breaks in a clamp, or if for any reason attributable to faulty technique, an individual measurement falls markedly below the average test result for the sample unit, such individual measurement shall be disregarded and another specimen shall be tested.

5.7 Calculation. The tenacity of a specimen tested shall be calculated as follows:

METHOD 4100

$$T = \frac{S}{D}$$

Where: T = Tenacity in g/denier

S = Strength in g

D = Yarn size in denier

or:

$$T = \frac{S \times 453.6}{D}$$

Where: T = Tenacity in g/denier

S = Strength in pounds

D = Yarn size in denier

or:

$$T_m = T \times 88.3$$

Where: T_m = Tenacity in mN/tex

T = Tenacity in g/den

6. REPORT

6.1 Unless otherwise specified in the procurement document, the breaking strength of a sample unit shall be the average of the specimens tested. Individual values used to calculate the average shall also be reported. All values shall be reported to the nearest 0.1 pound (to the nearest 0.1N).

6.2 Unless otherwise specified in the procurement document, the elongation shall be determined and reported at the point of rupture of the specimen. It shall be reported as the percent elongation of the specimen tested and shall be calculated from the curve drawn on the autographic recording mechanism. The elongation of a sample unit shall be the average of specimens tested and shall be reported to the nearest 1.0 percent.

6.3 Tenacity. The tenacity of a sample unit shall be the average of the specimens tested.

METHOD 4100

6.4 The individual values used to calculate the average shall also be reported.

7. NOTES

7.1 The Tex system for measuring the linear density of yarns is a direct system based on mass per unit length and employs metric units of length and weight. The Tex unit, g/kilometer (1000 meters) may be calculated from other numbering systems as follows:

Yarn number in tex units =

$$= \frac{310.034}{\text{wool run number}}$$

$$= \frac{590.541}{\text{cotton hank number}}$$

$$= \frac{885.812}{\text{worsted hank number}}$$

$$= \frac{1653.52}{\text{linen lea number}}$$

$$= \frac{1653.52}{\text{wool cut number}}$$

$$= \frac{\text{denier}}{9.0}$$

Example: Cotton hank number = 60's

Yarn number in tex units = $\frac{590.541}{60} = 9.842$ (size)

STRENGTH, BREAKING OF THREAD AND YARN; SKEIN METHOD

1. SCOPE

1.1 This method is intended for determining the breaking strength of single or plied thread and yarns in skein form.

2. TEST SPECIMEN

2.1 Unless otherwise specified in the procurement document, the specimen shall be a skein containing 120 yards (110 m).

3. NUMBER OF DETERMINATIONS

3.1 Unless otherwise specified in the procurement document, four specimens shall be tested from each sample unit.

4. APPARATUS

4.1 The machine shall consist of three main parts:

- (a) straining mechanism;
- (b) spools for holding specimen (skein);
- (c) load and elongation recording mechanism(s).

4.1.1 Straining mechanism. A machine wherein the specimen is held by two spools and strained by a uniform movement of the pulling clamp shall be used. Unless otherwise specified in the procurement document, the machine shall be adjusted so that pulling clamp shall have a uniform speed of 12 ± 0.5 inches (305 + 13mm) per minute.

4.1.2 Spools for holding the specimen. The spools for holding the specimen shall be cylindrical, with a diameter not less than one inch (25 mm), a length of not less than one-inch (25 mm) and shall be so supported that at least one spool can turn freely on its axis. The distance between the spools at the start of the test shall be just sufficient to allow the skein to be placed on the spools in a wide flat band.

4.1.3 Load recording mechanism. Calibrated dial, scale or chart to indicate applied load and elongation. Unless otherwise specified for load determination, the machine shall be adjusted or set so that the maximum load required to break the specimen will remain indicated on the calibrated dial, scale or chart of the autographic recording mechanism.

METHOD 4104

4.2 Yarn reel. A reel having a perimeter of 1.5 yards (1.37 m), accurate to ± 0.1 percent equipped with means to record length, apply tension and spread yarn evenly on the reel.

5. PROCEDURE

5.1 Unless otherwise specified in the procurement document, this test shall be performed on thread and yarn conditioned in accordance with Section 4 of this Standard. Conditioning can be performed either before or after reeling, but it will be accomplished quicker if the specimens are conditioned in skein form.

5.2 Preparation of specimen.

5.2.1 Thread and yarn wound on cones, bobbins, cops, small flanged spools or tubes. For thread and yarn wound on cones, bobbins, cops, small flanged spools or tubes, the specimen shall be drawn from the top of the package at a speed of 100 to 300 revolutions per minute of the reel. The thread or yarn shall be passed through the guides in such a way that the tension in the running thread or yarn is sufficient to straighten it, but not high enough to cause serious stretching. If the reel has only one pigtail guide per skein, tension shall be applied by taking one full wrap around the guide. If the reel has two or more guides, the thread or yarn shall pass straight through the guides onto the reel, the angle of the guides supplying the necessary tension.

5.2.2 Thread and yarn wound on large flanged spools, large tubes, bobbins or similar put-up. For packages such as large flanged spools, large tubes, certain warp-wound bobbins or similar put-up, the yarn shall be drawn from the side at a speed of 20 to 30 revolutions per minute of the reel. If the reel has two or more guides, the yarn shall pass straight through to the reel. Judgement must be used in applying tension on yarns having a small or large amount of twist.

5.2.3 If the sample has been previously wound in skein form, the skein shall be mounted on an umbrella reel from which a single end may be drawn, and passed through the guides onto the reel used to prepare the specimen for test, the angle of the guides supplying the necessary tension.

5.2.4 The finishing end of the skein shall be tied to the starting end of the skein using a square knot and in such a manner that will not add length to the skein.

5.3 Preliminary adjustments.

5.3.1 Prior to testing the operator shall verify that the apparatus has been calibrated in accordance with the procedure required for the make and model being used.

METHOD 4104

5.3.2 If an autographic mechanism is used, it shall be determined by a trial run of the apparatus that it is operating properly. Be sure that the pen has an ample supply of ink to avoid depletion of the supply during test.

5.3.3 Check the speed of the machine to insure that it is as required and check alignment of spools with respect to each other.

5.4 Testing.

5.4.1 Transfer the skein from the reel to the test apparatus (spools of machine) handling carefully. Keep the thread or yarn of the specimen parallel and the skein flat with no bunching or twisting. Do not stretch or jerk the thread or yarn and do not allow to kink.

5.4.2 When mounting a specimen that has a tendency to curl, the specimen may be held taut and in place by hand until the machine is started and the pulling spool removes the slack from the skein.

5.4.3 Force is applied to break the specimen and this force read from the chart, dial or scale shall be recorded.

6. REPORT

6.1 The breaking strength of the sample unit shall be the average of the specimens tested and shall be reported to the nearest 0.5 pound (to the nearest 1N).

6.2 Each individual value used to calculate the average shall also be reported.

STRENGTH AND ELONGATION, BREAKING; TEXTILE

WEBBING, TAPE AND BRAIDED ITEMS

1. SCOPE

1.1 This method is intended for determining the breaking strength and elongation of textile webbing, tape and braided items.

2. TEST SPECIMEN

2.1 The specimen shall be a single length of 54 inches (1372 mm) and the full width of the material as received.

3. NUMBER OF DETERMINATIONS

3.1 Unless otherwise specified in the procurement document, five specimens shall be tested from each sample unit.

4. APPARATUS

4.1 The machine shall consist of three main parts:

- (a) Straining mechanism
- (b) Clamps
- (c) Load and elongation recording mechanism(s)

4.1.1 Straining mechanism. A machine wherein the specimen is held by two clamps and subjected to strain by a uniform movement of the pulling clamp.

4.1.1.1 Unless otherwise specified in the procurement document, the machine shall be adjusted so that the pulling clamp shall have a uniform speed of 3.0 ± 1.0 inches (76 ± 25 mm) per minute.

4.1.2 Clamps.

4.1.2.1 Split drum. Unless otherwise specified in the procurement document, the machine shall have two clamps, split drum type as shown in Figure 4108 and the distance between the clamps (gage length) shall be $10 \pm 1/2$ inches ($254 \text{ mm} \pm 13 \text{ mm}$) center to center.

METHOD 4108

4.1.2.2 Flat surface clamps. When clamps are specified other than split drum type the machine shall have two clamps with two jaws on each clamp. Each jaw face shall have a flat, smooth gripping surface. The design shall be such that one gripping surface or jaw may be an integral part of the rigid frame of the clamp or be fastened to allow a slight vertical movement while the other gripping surface or jaw shall be completely movable. Unless otherwise specified the dimension of the jaws parallel to the application of the load shall measure one inch (25 mm) and the dimension of the jaws perpendicular to this direction shall be greater than the width of the specimen being tested. All edges which might cause a cutting action shall be rounded to a radius not greater than 1/64 inch (0.4 mm). The test specimen shall be a minimum of 6 inches (152 mm). The pulling clamp shall have a uniform speed 12 ± 0.5 inches (305 \pm 13 mm) per minute. Unless otherwise specified, the distance between the jaws (gage length) shall be 3 inches (76 mm) at the start of the test.

4.1.3 Load recording mechanism(s). Calibrated chart, dial or scale to indicate applied load. Unless otherwise specified for load determination, the machine shall be adjusted or set so that the maximum load required to break the specimen shall remain indicated on the calibrated chart, dial or scale after the specimen has ruptured.

4.1.4 Capacity. The machine shall be of such capacity that the maximum load required to break the specimen shall be not greater than 85 percent or less than 15 percent of the rated capacity.

4.1.5 Machine efficiency. The error of the machine shall not exceed 2 percent for loads up to and including 50 pounds (223 N) and shall not exceed 1 percent for loads greater than 50 pounds (223 N).

5. PROCEDURE

5.1 Reparation of specimen.

5.1.1 Unless otherwise specified in the procurement document, the specimens tested shall be conditioned and tested under standard conditions in accordance with Section 4 of this Standard.

5.1.2 When it is required that the elongation of the specimen shall be determined, two fine ink marks shall be placed on the specimens spaced five inches (127 mm) apart. The marks shall be placed in such a manner that neither mark is closer than 1-1/2 inches (38 mm) to each clamp when the specimen is mounted in the clamps.

5.2 The specimen shall be placed in the clamps of the machine with the long dimension parallel to the application of the load. When measurement of elongation is required a slight tension or a specific load required by the applicable procurement document shall be applied to the specimen as it is placed in the clamps and the two, fine ink marks shall not be closer than 1-1/2 inches (38 mm) to either clamp.

METHOD 4108

5.3 Breaking strength. Force shall be applied to the specimen at such a rate that the clamp through which the force is applied will move at a rate of 3.0 ± 1.0 inches (76 ± 25 mm) per minute until the specimen is ruptured. After rupture of the specimen, the breaking load shall be read from the dial, scale or chart and the value recorded.

5.4 Elongation. Elongation shall be determined on the same specimen being tested for breaking strength. The equipment will be stopped and the distance between the two fine ink marks measured with calipers at the load level specified in the applicable procurement document and recorded.

5.5 If a specimen slips between the clamps, breaks in or at the edges of the clamps, or if for any reason attributable to faulty technique, an individual measurement falls markedly below the average test result for the sample unit, such result shall be discarded and another specimen shall be tested.

6. REPORT

6.1 The breaking strength of the sample unit shall be the average of the results obtained from the five specimens tested and shall be reported separately as follows:

<u>Breaking strength</u>	<u>Reported to nearest</u>
0-500 lbs (0-2220 N)	1 lb (1 N)
501 and up (2221 N and up)	5 lbs (10 N)

6.2 The elongation of the sample unit shall be the average of the specimens tested and shall be reported to the nearest 1.0 percent. The report shall state that elongation was measured at break or at the load specified.

6.3 Each individual value used to calculate the average shall also be reported.

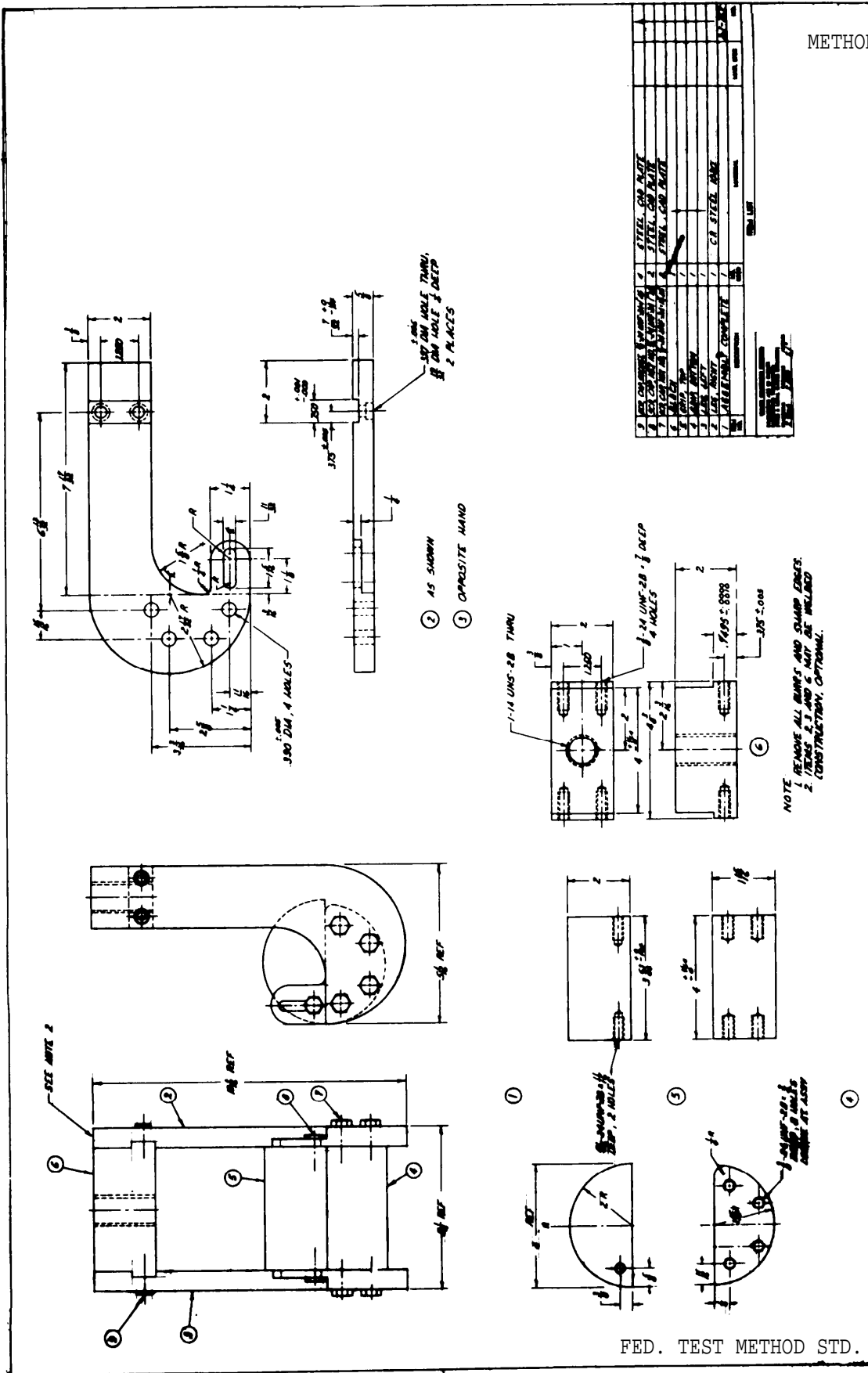

FIGURE 4108 - Test jaws for high strength textiles, assembly complete.

CRIMP IN YARNS FROM CLOTH; DEAD-LOAD METHOD

1. SCOPE

1.1 This method is intended for determining the crimp in yarns after they have been removed from cloth. This method is considered adequate for normal inspection work, requiring less time to perform than Method 4112.

2. TEST SPECIMEN

2.1 The specimen shall be a yarn removed from a 14-inch (356 mm) length of cloth.

3. NUMBER OF DETERMINATIONS

3.1 Unless otherwise specified in the procurement document, 10 specimens in each of the warp and filling directions shall be tested from each sample unit.

4. APPARATUS

4.1 Twist tester. Twist tester equipped with a yarn-loading or similar device, which can apply a load within an approximate range of 0 to 300 g.

4.2 Ruler. Fifteen inch (381 mm) (minimum) ruler graduated in 1/16 inch (1 mm) divisions.

4.3 Marking device. Pen or other suitable device for marking the cloth.

5. PROCEDURE

5.1 Unless otherwise specified In the procurement document, the specimens tested shall be conditioned. and tested under standard conditions in accordance with Section 4 of this Standard.

5.2 Preparation of specimen.

5.2.1 A length of 14 Inches (356 mm) shall be cut from the cloth parallel to the yarn to be tested. Tearing of the cloth to obtain a straight edge shall not be permitted. Several yarns shall be raveled from the cloth along the cut edge to remove any severed or damaged yarns. Two parallel lines 10 inches (254 mm) apart (original length) shall be marked on the cloth. A yarn passing through these marks shall be raveled for a distance of about 2 inches (51 mm) beyond each mark, care being taken to avoid untwisting or stretching the yarn. At least three bobbin areas shall be included in the specimens prepared from the filling direction of the cloth. Generally specimens taken from the ends and center of a yard of cloth will include three bobbin areas.

METHOD 4110

5.2.2 The specimen shall be mounted in the twist tester with the jaws set 10 inches (254 mm) apart. The marked points shall be placed at the edges of the two jaws. A load shall be applied to the yarn just sufficient to remove the crimp when the yarn is examined visually or with the aid of a lens. The tension shall be applied slowly to avoid an impact loading. The total distance between the marks (jaws) shall be measured.

5.3 An indication of the necessary load in g may be obtained by dividing a constant (K) by the single equivalent yarn number. In the cotton system K = 156. In the Tex system, 0.25 g per tex unit load shall be applied to the specimen being tested.

5.4 Calculation of results.

$$\text{Crimp, percent} = \frac{L - L_0}{L_0} \times 100$$

Where:

L = Distance in inches (mm) between the marks on the straightened yarn

L₀ = Original length in inches (mm) between the marks

6. REPORT

6.1 The crimp of the sample unit shall be the average of the results obtained from the specimens tested in each of the warp and filling directions respectively and shall be reported separately to the nearest 0.1 percent.

6.2 Each individual value used to calculate the average shall also be reported.

CRIMP IN YARNS FROM CLOTH; LOAD-ELONGATION METHOD

1. SCOPE

1.1 This method is intended for determining the crimp in yarns that have been removed from cloth. It is considered preferable for use where a higher degree of accuracy is desired than that obtained by using Method 4110, but is more time consuming.

2. TEST SPECIMEN

2.1 The specimen shall be a yarn removed from a 14-inch (356 mm) length of cloth.

3. NUMBER OF DETERMINATIONS

3.1 Unless otherwise specified in the procurement document, 10 specimens in each of the warp and filling directions shall be tested from each sample unit.

4. APPARATUS

4.1 Thread strength tester. Single-thread strength tester equipped with flat-type jaws, suitable for determining the breaking strength of the yarns. Drum clamps or similar type clamps shall not be used.

4.1.2 Recording device and charts. Suitable autographic recording device and charts.

5. PROCEDURE

5.1 Unless otherwise specified in the procurement document, the specimens tested shall be conditioned and tested under standard conditions in accordance with Section 4 of this Standard.

5.2 Preparation of specimen.

5.2.1 A length of 14 inches (356 mm) shall be cut from the cloth parallel to the yarn to be tested. Tearing of the cloth to obtain a straight edge shall not be permitted. Several yarns shall be raveled from the cloth along the cut edge to remove any severed or damaged yarns. Two parallel lines 10 inches (254 mm) apart (original length) shall be marked on the cloth. A yarn passing through these marks shall be raveled for a distance of about 2 inches (51 mm) beyond each mark, care being taken to avoid untwisting or stretching the yarn.

METHOD 4112

At least three bobbin areas shall be included in the specimens prepared from the filling direction of the cloth. Generally, specimens taken from the ends and center of a yard of cloth will include three bobbin areas.

5.2.2 The specimen shall be placed in the clamps of the machine which are 10 inches (254 mm) apart at the start of the test. The marked spots on the specimen shall coincide with nips at the clamps, care being taken to avoid untwisting of the yarn. Sufficient tension shall be applied to the specimen to stretch or, if desired, break the specimen.

5.3 When an inclined plane type machine is used, impact loading caused by sudden movement of the carriage shall be minimized by removing the slack from the specimen prior to application of the load. This may be accomplished by manually controlling the descent of the carriage as the angle of the inclined plane increases until the instant the slack is removed from the specimen.

5.4 A load-elongation diagram shall be obtained on the autographic recording device for the specimen, and the extension due to crimp measured from the diagram as follows:

5.4.1 In the load-elongation diagram of a cotton yarn, Figure 4112, the region of the curve (AD) represents the removal of the crimp and the initial stretch of the yarn; and the straight region (DE) represents the elastic (stretch) region of the specimen. A line (DC) shall be drawn through the lower portion representing the elastic portion of the curve intersecting the line AX at C. The distance AC is the crimp in the specimen.

5.4.2 If required, the tension necessary to straighten the yarn to its length before weaving shall be determined as follows:

A line perpendicular to AX shall be passed through point C to intersect AD at B. The distance CB (AL) shall represent the required tension. (Figure 4112).

5.5 Calculation of results.

5.5.1 The crimp shall be calculated as follows:

$$\text{Crimp Percent} = \frac{\text{distance AC, inches}}{10} \times 100$$

OR

$$\text{Crimp Percent} = \frac{\text{distance AC, mm}}{254 \text{ mm}} \times 1000$$

6. REPORT

6.1 The crimp of the sample unit shall be the average of the results obtained from the specimens tested in each of the warp and filling directions respectively and shall be reported separately to the nearest 0.1 percent.

6.2 Each individual value used to calculate the average shall also be reported.

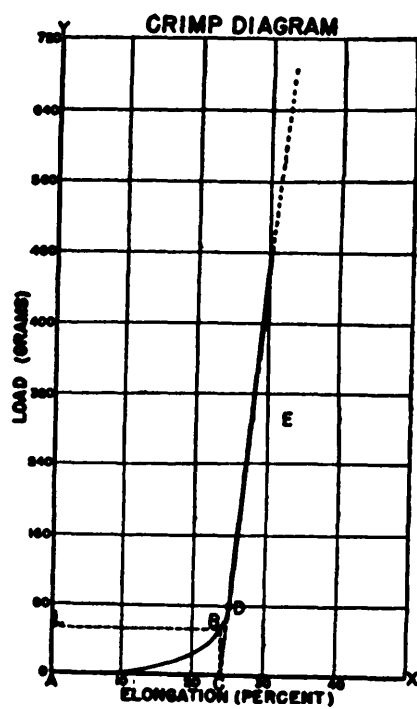

FIGURE 4112

ABRASION RESISTANCE OF YARN, THREAD, AND LIGHT CORDAGE

UNIFORM-ABRASION (SCHIEFER) METHOD

1. SCOPE

1.1 This method is intended for determining the resistance to abrasion of dry and wet yarns, threads, and light cordage. It is applicable to products which vary in fiber content, construction, finishing or coating treatment, and kind or amount of auxiliary substances.

2. TEST SPECIMEN

2.1 The specimen shall be a continuous length of the product threaded in the clamp described in 4.1.4 to form a series of short loops on the circumference of the four concentric circles.

3. NUMBER OF DETERMINATIONS

3.1 Unless otherwise specified in the procurement document, six specimens shall be tested from each sample unit.

4. APPARATUS

4.1 Abrasion testing machine. An abrasion machine, figure 4308A, consisting of abrading mechanism, specimen supporting mechanism, and driving mechanism. Essentially, the surface of the abradant lies in a plane parallel to the plane surface supporting the specimen and presses upon the specimen. The abradant and specimen rotate in the same direction at very nearly but not quite the same angular velocity, 250 r.p.m., on noncoaxial axis which are parallel to 0.001 inch (0.0254 mm). The small difference in speed is to permit each part of the specimen to come in contact with a different part of the abradant at each rotation.

4.1.1 Abrading mechanism. The abrading mechanism included the abradant (letter A, in figure 4308A) mounted at the lower end of a shaft; weights placed upon the upper end of the shaft to produce constant pressure between abradant and specimen throughout the test; lever and cam for raising and lowering the abradant; shaft; and weights (letter B, in figure 4308A). A counter-weight for balancing the abradant shaft is used when tests are to be carried out at low pressure.

METHOD 4308

4.1.2 Driving mechanism. The driving mechanism consists of a motor-driven auxiliary drive shaft connected to the abradant-shaft and specimen-shaft by spur gears.

4.1.3 Resettable counter. The machine is equipped with a resettable counter, (letter G, in figure 4308A) to indicate the number of rotations in a test.

4.1.4 Clamp. The clamp shall consist of a circular plastic plate 2-10/16 inches (67 mm) in diameter and 9/16 inch (14 mm) high with holes arranged in four concentric circles for supporting the yarn, thread or cordage during abrasion, as shown in figure 4308B. It shall permit simultaneous exposure to abrasion of 54 portions of the specimen. Pins on the periphery of the plate shall be provided for fastening the ends of the specimen after threading. An aluminum disk shall be screwed to the bottom of the plate to hold the individual lengths of the specimen in position. For wet abrasion tests a soft rubber gasket shall be inserted between this aluminum disk and the bottom of the plate to prevent leakage of water from the holes at the bottom of the plate.

5. PROCEDURE

5.1 Unless otherwise specified in the procurement document, the load of the abradant of the specimen shall be one pound (454 g).

5.2 Unless otherwise specified in the procurement document, the spring steel blade abradant shall be used.

5.2.1 The abradant shall be wiped off with carbon tetrachloride or other suitable solvent after each test to prevent the accumulation of finishing material on the blades.

5.3 Preparation of specimen. The yarn, thread, or cord shall be threaded through the holes of the plastic plate, going around the plate in a counter-clockwise direction, starting at all times at the same hole of the outer circle. Moderate tension during threading shall be applied by hand.

5.3.1 The loops shall be oriented with respect to each other at angles differing by equal increments in the range from 0° to 360°.

5.3.2 Wet abrasion test. In wet abrasion tests the specimen mounted in the plate is thoroughly wet by immersion in water prior to inserting the plate in the machine. The plate is then mounted in the machine and the surface is flooded with an excess of water. After each 1000 rotations of abrasion, or as specified, the machine is stopped and the surface of the plate flooded with an excess of water.

METHOD 4308

5.4 A test shall be carried out as follows: mount the specimen in the clamp taking care that it is clamped evenly and securely without distortion; place the specimen assembly in position in the machine, and lower the abradant on the specimen by rotating the upper cam; set the counter at zero and start the machine.

5.5 The test shall be continued for the required number of rotations of abrasion or until the specimen is to be inspected. The machine shall be stopped, the abradant raised by the upper cam, and the clamp and specimen removed from the machine.

5.6 The specimen shall be inspected or measured as required in the procurement document without removing it from the clamp. Replace the assembly in the machine and continue the test, repeating the inspection at intervals as required.

5.7 Evaluation.

5.7.1 Unless otherwise specified in the procurement document, the end point of abrasion shall be the number of rotations of the abradant relative to the specimen necessary to wear through 27 of the 54 exposed portions of the specimen.

5.7.1.1 The machine shall be stopped periodically for inspection of the abraded portions of the specimen. The number of loops completely worn through shall be noted at each stop. The cumulative frequency of worn loops shall be plotted against the number of rotations and the number of rotations corresponding to 27 worn loops shall be obtained from the plotted graph.

6. REPORT

6.1 Unless otherwise specified in the procurement document, the abrasion resistance of the sample unit shall be the average of the number of rotations obtained from the specimens tested and shall be averaged to the nearest 10 rotations.

6.1.1 Each individual value used to calculate the average shall also be reported.

7. NOTES

7.1 An abrasion machine and clamp of the type described in this method are manufactured by Frazier Precision Instrument Company, Inc., Silver Spring, MD 2907.

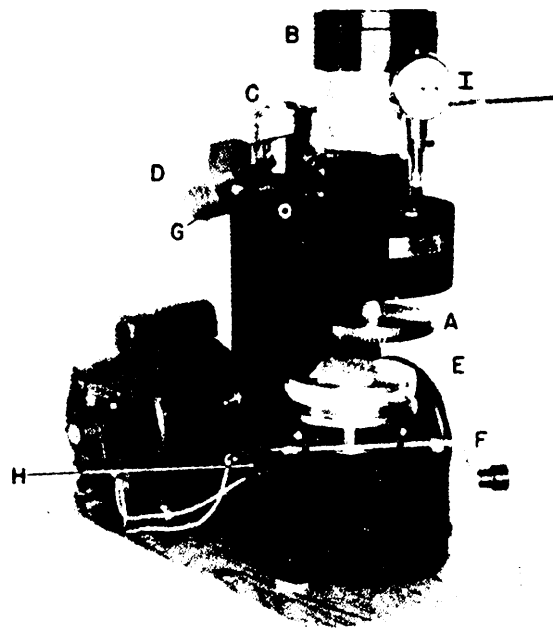

FIGURE 4308A - Schiefer abrasion testing machine.

- A* Abradant
- B* Weights on abradant shaft
- C* Cam and lever system for raising the abradant shaft, abradant, and weights
- D* Counterweight for balancing abradant and abradant shaft when tests are to be made at low pressures
- E* Specimen in place ready for test
- F* Cam for raising and lowering the specimen clamp seat
- G* Counter
- H* Microswitch
- I* Thickness gage

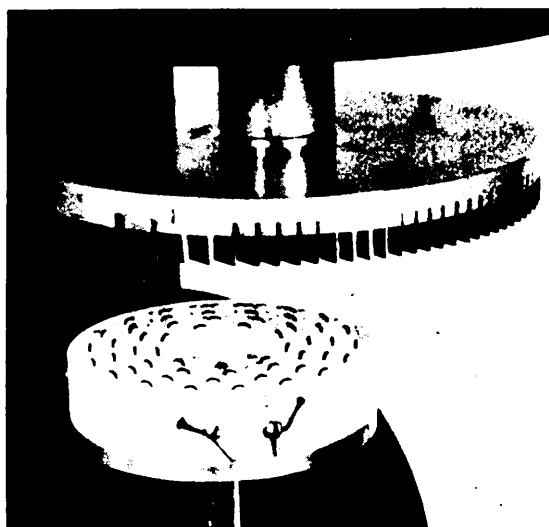

FIGURE 4308B

WATER ABSORPTION, DYNAMIC; TUMBLE JAR METHOD

1. SCOPE

1.1 This method is intended for determining the amount of water absorbed by thread, yarns, tapes, cords, braids, webbings, and narrow cloths when subjected to dynamic conditions.

2. TEST SPECIMEN

2.1 Unless otherwise specified in the procurement document, the specimen shall be 5 pieces of the material 6 to 36 inches (152 to 915 mm) in length, for cord, braid, tape, webbing, and similar materials as specified in Table I, and 1 cabled skein for thread, yarns, light cords, and light braids, prepared as specified in 5.1.

TABLE I

<u>Specimen Weight</u>	<u>Specimen Length</u>
0 thru 4 g/m	36 inches (915 mm)
5 thru 20 g/m	24 inches (610 mm)
21 thru 50 g/m	18 inches (457 mm)
51 thru 100 g/m	12 inches (305 mm)
101 g/m and over	6 inches (152 mm)

3. NUMBER OF DETERMINATIONS

3.1 Unless otherwise specified In the procurement document, two specimens (10 pieces) shall be tested from each sample unit for cords, braids, tapes, webbings, and similar materials, and three specimens shall be tested from each sample unit for thread, light cords, and light braids.

4. APPARATUS

4.2 Tumble jar. A tumble jar (see figure 4500A), cylindrical in shape, with approximate dimensions of 12 inches (305 mm) in height and 6 inches (152 mm) in diameter or between opposite flat faces, and with a capacity of approximately 6 L. The jar shall be of glass, corrosion-resistant metal, or chemical stoneware. The jar shall be mounted in a vertical position, in such a manner that it can be rotated around the horizontal axis passing through the center of the jar. Means shall be provided for rotating the jar around the axis at a rate of 55 ± 2 revolutions per minute. The jar shall be clean and thoroughly rinsed so that it is free from soap, detergent, and wetting agents (see 7.1).

METHOD 4500

4.2 Wringer. A wringer (see figure 4500B), of the household type, equipped with smooth rubber squeeze rolls 2-1/8 to 2-1/2 inches (54 to 64 mm) in diameter and not less than 11 inches (279 mm) or more than 16 inches (406 mm) in length. The rubber rolls shall have a Shore durometer hardness of 70 to 80 (A scale). The load exerted on the specimen shall be applied uniformly by means of a dead weight attached to the top roller. The total load of the roller, means of attaching the weight, and the weight itself shall be 60 pounds (27 kg). The rolls shall be power driven at such a speed that the specimen shall pass through the rolls at a rate of 1 inch (25 mm) per second.

4.3 Balance. Laboratory balance accurate to 0.01 g.

4.4 Blotting paper. The blotting paper dimensions shall be approximately 1 inch greater than the length and width of the specimens (see 7.3).

4.5 Yarn reel. A 54-inch (1.37 m) periphery skein reel or other suitable device for preparing a skein.

4.6 Twist tester. A twist tester or other suitable device for twisting skeins.

4.7 Container. Tared glass or plastic containers.

5. PROCEDURE

5.1 Preparation of thread, yarns, light cord and light braid specimens. The test specimens shall consist of 5.0 ± 1.0 g skeins made on a 54-inch (1.37 m) periphery skein reel. The skein shall be folded flat, then twisted around its long axis for a total of 25 turns using a twist tester (see figure 4500C). The twist must be inserted in the skein in the same direction as the final twist of the specimen. The two ends shall be brought together and the folded skein allowed to back twist on itself. The ends shall be tied off to prevent untwisting (see figure 4500D).

5.2 Time of rotation. Unless otherwise specified in the procurement document, the time of rotation of the jar (test time) shall be a minimum of 10 minutes for threads, yarns, light cords and light braids; and a minimum of 20 minutes for webbings, tapes, heavy cords and braids, and narrow cloths.

5.3 Weight of original specimen. The specimen, 5 pieces of cord, braid, tapes, webbing, or narrow cloths, or 1 cable skein for lighter materials, shall be conditioned and weighed to the nearest 0.1 g. This is the "Weight of the original conditioned specimen", and in the calculation of results is designated as 0 1. Each individual piece of the specimen for cord, braids, tapes, and webbings shall be marked to maintain its identity.

METHOD 4500

One L of distilled water for threads, yarns, light cords and light braids, and 2 L of water for webbings, tapes, or narrow cloths-at a temperature of $80^{\circ} \pm 2^{\circ}\text{F}$ ($27^{\circ}\text{C} \pm 1^{\circ}\text{C}$) shall be placed in the tumble jar (see 4.1) and the specimen added.

5.3.1 Cords, braids, webbings, tapes, or narrow cloths. Two specimens (10 pieces) may be tested at the same time, provided each specimen is taken from a different sample unit. If less than 2 specimens are tested, a clean specimen of comparable weight, finish, size, and type of cloth shall be run as ballast with the specimen undergoing test. Care shall be taken that the material in the jar during any run shall be the equivalent weight of the 2 specimens.

5.3.1.1 The jar and contents shall be rotated at the rate of 55 ± 2 revolutions per minute for the time specified.

5.3.1.2 At the end of the required running time, one piece of the specimen shall be run through the wringer smoothly with the lengthwise direction of the specimen perpendicular to the length of the rollers.

5.3.1.3 The same piece of the specimen shall immediately be placed smoothly between 2 sheets of blotting paper. The specimen and blotters shall be passed through the rollers of the wringer by the procedure described in 5.3.1.2.

5.3.1.4 The piece of material shall be left between the 2 blotters until all 5 pieces (between sheets of blotting paper) have been passed between the rollers as described in 5.3.1.2 and 5.3.1.3.

5.3.1.5 Final weight of specimen. The 5 pieces constituting the specimen shall then be removed from the blotting paper and weighed immediately in a tared closed container to the nearest 0.1 g. This is the "Final weight of the specimen", and in the calculation of results is designated as "F".

5.3.2 Thread yarns, light cords and light braids. No more than 1 cabled skein shall be tested in the jar at one time.

5.3.2.1 The jar and contents shall be rotated at the speed of 55 ± 2 revolutions per minute for the time specified.

5.3.2.2 At the end of the required running time, the specimen shall be run through the wringer smoothly with the lengthwise direction of the specimen perpendicular to the length of the rollers.

METHOD 4500

5.3.2.3 The same specimen shall immediately be placed smoothly between 2 sheets of blotting paper. The specimen and blotters shall be passed through the rollers of the wringer by the procedure described in 5.3.2.2.

5.3.2.4 Final weight of specimen. The specimen shall then be removed from the blotting paper and weighed immediately in a tared closed container to the nearest 0.1 g. This is the "Final weight of the specimen", and in the calculation of results shall be designated as "F".

5.4 Care shall be taken at all times to keep evaporation of moisture from the specimen to a minimum.

5.5 Calculation of results. The dynamic absorption shall be calculated as follows:

$$\text{Dynamic absorption, percent} = \frac{F - O}{O} \times 100$$

Where: O = Original weight of the specimen.

F = Final weight of the specimen.

6. REPORT

6.1 The dynamic absorption of the sample unit shall be the average of the results obtained from the specimens tested, and shall be reported to the nearest 0.1 percent.

6.2 Each individual value used to calculate the average shall also be reported.

7. NOTES

7.1 A tumble jar suitable for conducting this test may be purchased from Atlas Electric Devices Co., 4114 N. Ravenwood Ave., Chicago 13, Illinois, and Illinois and Mico Instrument Co., 80 Trowbridge St., Cambridge, MA 02138.

7.2 If the material for test is subject to excessive raveling, a drop of liquid latex or rubber cement should be spread on the yarns at each corner to prevent raveling. Care should be exercised in the selection of the latex or rubber cement to insure impurities are not present which would affect results.

7.3 The blotting paper is available from: James River Paper Company, P.O. Box 2218, Richmond, VA 23217.

DYNAMIC ABSORPTION TEST

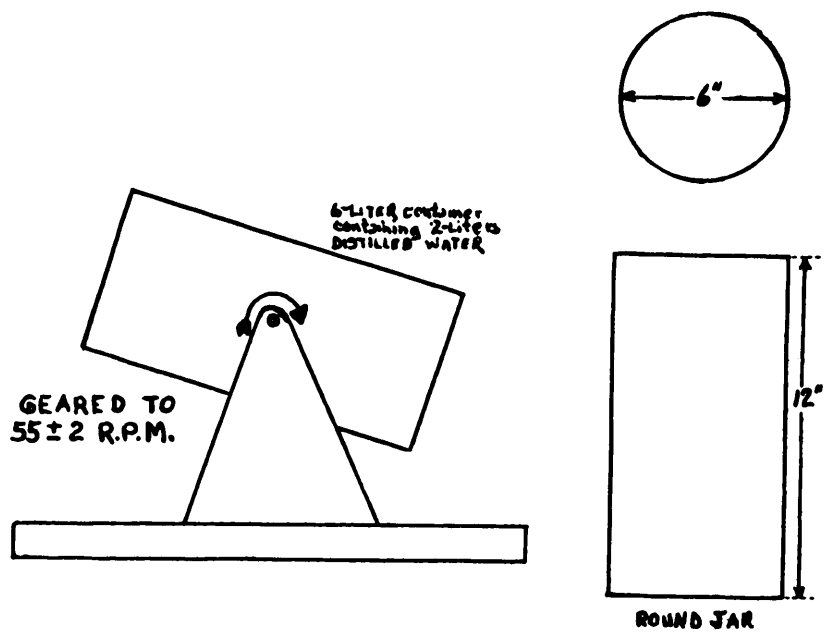

FIGURE 4500A - TUMBLE JAR

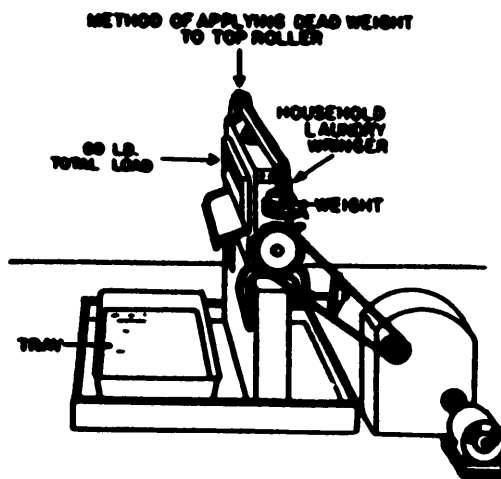

FIGURE 4500B- WRINGER

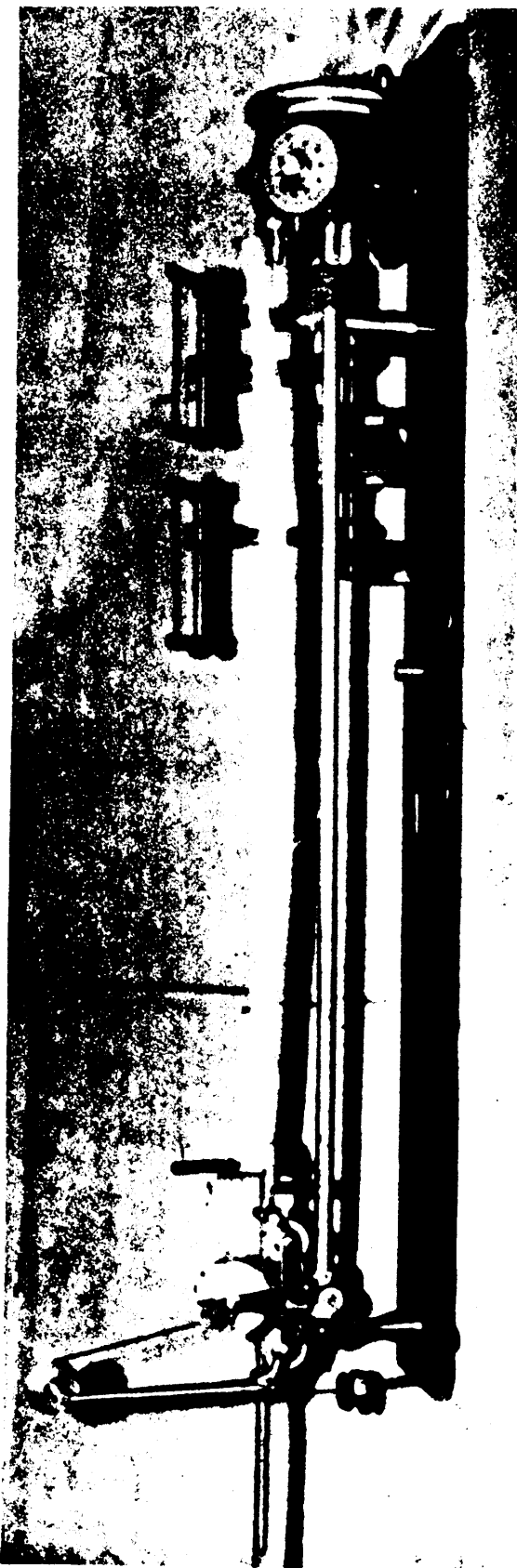

FIGURE 4500C - TWIST TESTER

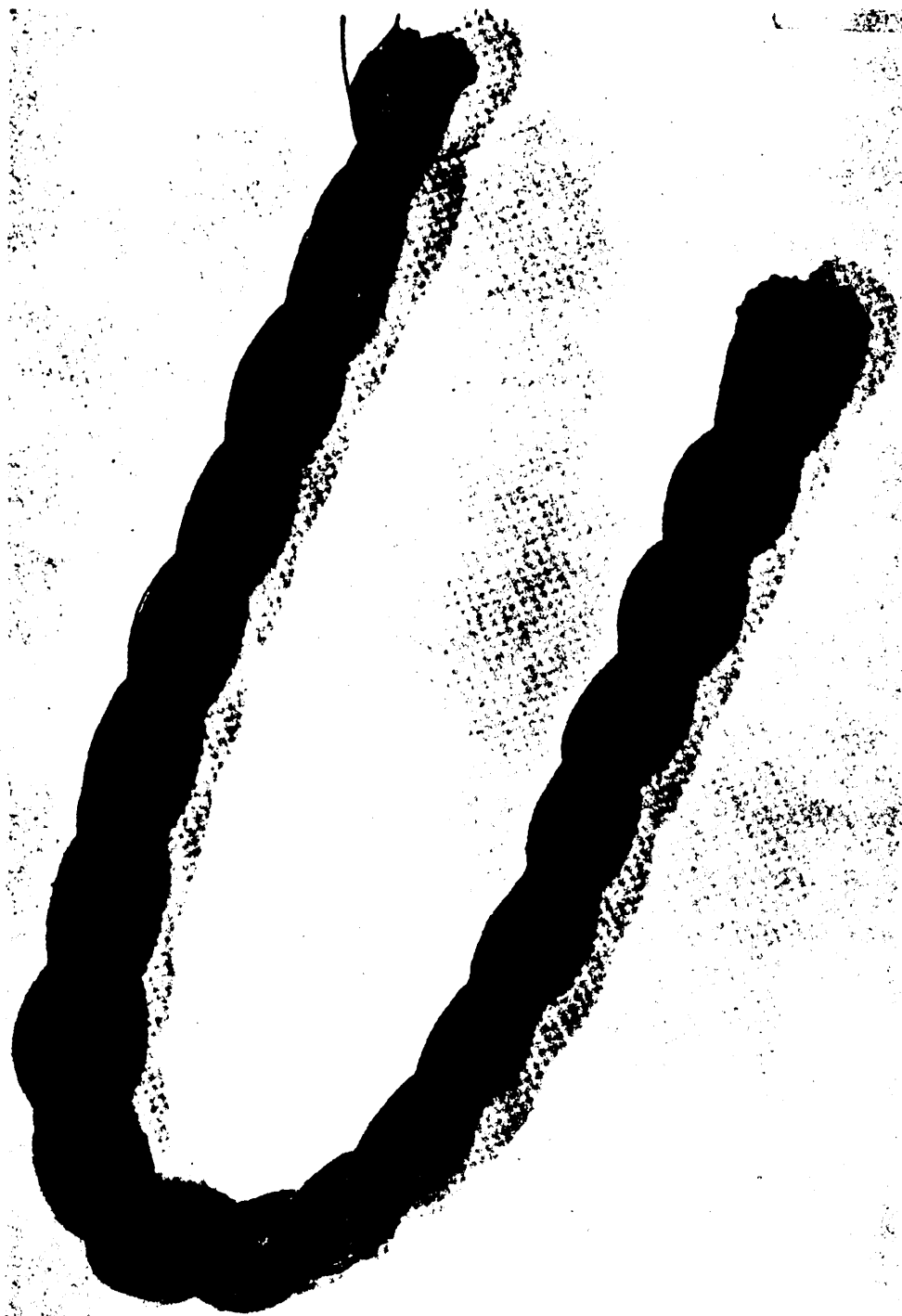

FIGURE 4500D - FOLDED SKEIN

WATER ABSORPTION: THREAD, CORD, BRAID, TAPE,

WEBBING: IMMERSION METHOD

1. SCOPE

1.1 This method is intended for determining the amount of water absorbed by cord, braid, thread, tape, webbing and related materials when subjected to static conditions.

2. TEST SPECIMEN

2.1 Unless otherwise specified in the procurement document, the specimen shall be a piece of the material 6 to 24 inches (152 to 610 mm) in length for cord, braid, tape webbing, and similar materials, and a cabled skein for thread, prepared as specified in 5.1.

2.1.1 Departure from the required length of cord, braid, tape, webbing, and similar materials shall be permitted when necessary so that those which are appreciably light shall weigh not less than 4 g.

2.1.2 Materials such as light cord, thread, and light braid shall be prepared in the form of a cabled skein as specified in 5.1. Webbing, tape, heavy cord, and heavy braid, when applicable, shall be folded to approximate 6-inch (152 mm) folds.

3. NUMBER OF DETERMINATIONS

3.1 Unless otherwise specified in the procurement document, three specimens shall be tested from each sample unit.

4. APPARATUS AND METHOD CITED

4.1 Apparatus (as shown in fig. 5502).

4.1.1 Blotting paper. The blotting paper dimensions shall be approximately 1 inch (25 mm) greater than the length and width of the specimen (see 7.1).

4.1.2 Wringer. Wringer as described in Method 5502.

4.1.3 Sinker and tank. Sinker and tank varying in size with the size of the specimen, and balance as described in Method 5502.

METHOD 4502

4.1.4 Yarn reel. A 54-inch (1.37 m) periphery skein reel or other suitable device for preparing the specimen.

4.1.5 Twist tester. A twist tester or other suitable device for twisting skeins.

4.2 Method cited.

Method 5502, Water Resistance of Cloth; Immersion Absorption Method.

5. PROCEDURE

5.1 Unless otherwise specified in the procurement document, this test shall be performed on material conditioned in accordance with Section 4 of this standard.

5.2 Preparation of thread, light cord, and light braid specimens. The test specimen shall consist of a 5 ± 1.0 g skein made on a 54-inch (1.37 m) periphery skein reel. The skein shall be folded flat, then twisted around its long axis for a total of 25 turns by use of a twist tester (see fig. 4502A). The twist must be inserted in the skein in the same direction as the final twist of the thread (see fig. 4502B). The two ends shall be brought together and the folded skein allowed to back twist on itself. The ends shall be tied off to prevent untwisting (see fig. 4502C).

5.3 Weight of the original specimen. Three specimens shall be conditioned and weighed as a unit to the nearest 0.05 g. This is the "Original conditioned weight of the specimen" and is designated as "O".

5.4 Unless otherwise specified in the procurement document, the time of immersion shall be 20 ± 1 minutes.

5.5 The specimen shall be attached to the sinker and immersed for the required time in a tank of distilled water at a temperature of $81^\circ \pm 0.5^\circ\text{F}$ ($27^\circ \pm 1.0^\circ\text{C}$). The depth of the water shall be so regulated that, with the sinker resting on the bottom of the tank, the top of the specimen when held in a vertical position shall be immersed under a 2-inch (51 mm) head of water.

5.6 At the end of the immersion period, the specimen shall be removed from the bath and the sinker detached. The specimen shall be spread out and immediately placed as flat as possible between two blotters and passed through the wringer at the rate of 1 inch (25 mm) per second.

5.6.1 When the specimen is being passed through the wringer, the longitudinal direction of the material shall be perpendicular to the axis of the rolls.

5.7 Final weight of the specimen. After squeezing through the wringer, the specimen shall be weighed as a unit immediately in a tared closed container to the nearest 0.05 g. This is the "Final weight of the specimen" and is designated as "F". Care shall be taken to keep evaporation of moisture from the specimen to a minimum.

5.8 Calculation of results. The immersion absorption of the specimen shall be calculated as follows:

$$\text{Immersion absorption, percent} = \frac{F - O}{O} \times 100$$

Where: O = Original conditioned weight of the specimen.

F = Final weight of the specimen

6. REPORT

6.1 The water absorption of the sample unit shall be the average of the results obtained from the specimens tested, and shall be reported to the nearest 0.1 percent.

6.1.1 Each individual value used to calculate the average shall also be reported.

7. NOTES

7.1 The blotting paper is available from: James River Paper Company, P.O. Box 2218, Richmond, VA 23217.

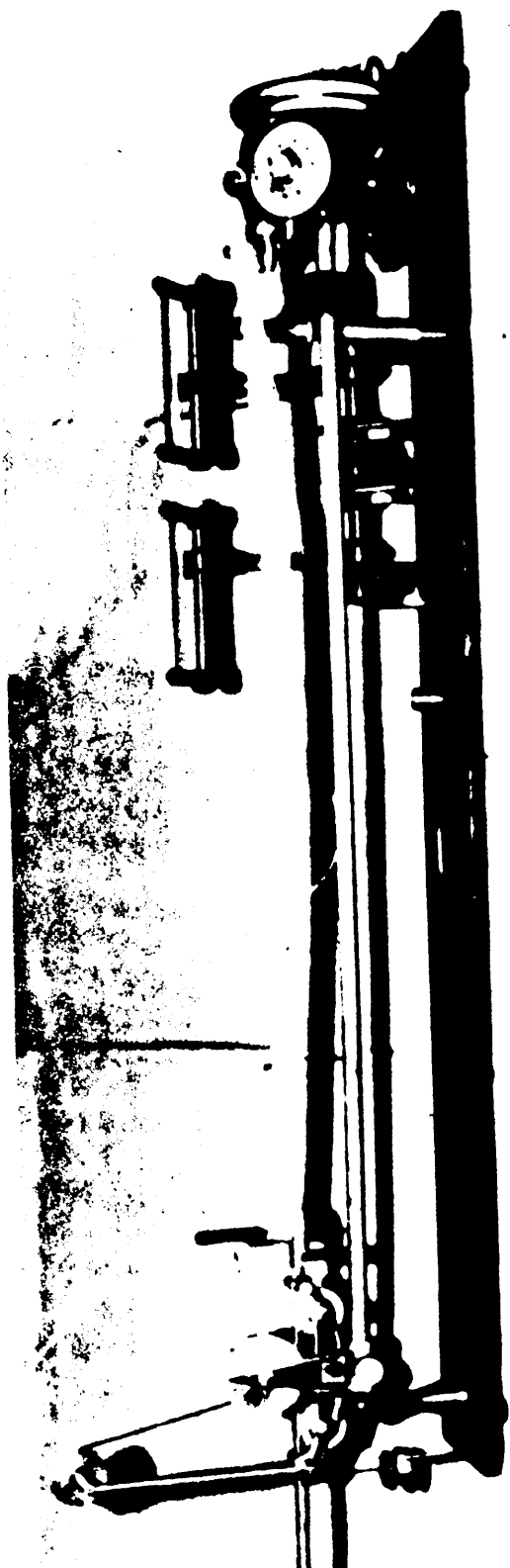

FIGURE 4.502A - TWIST TESTER

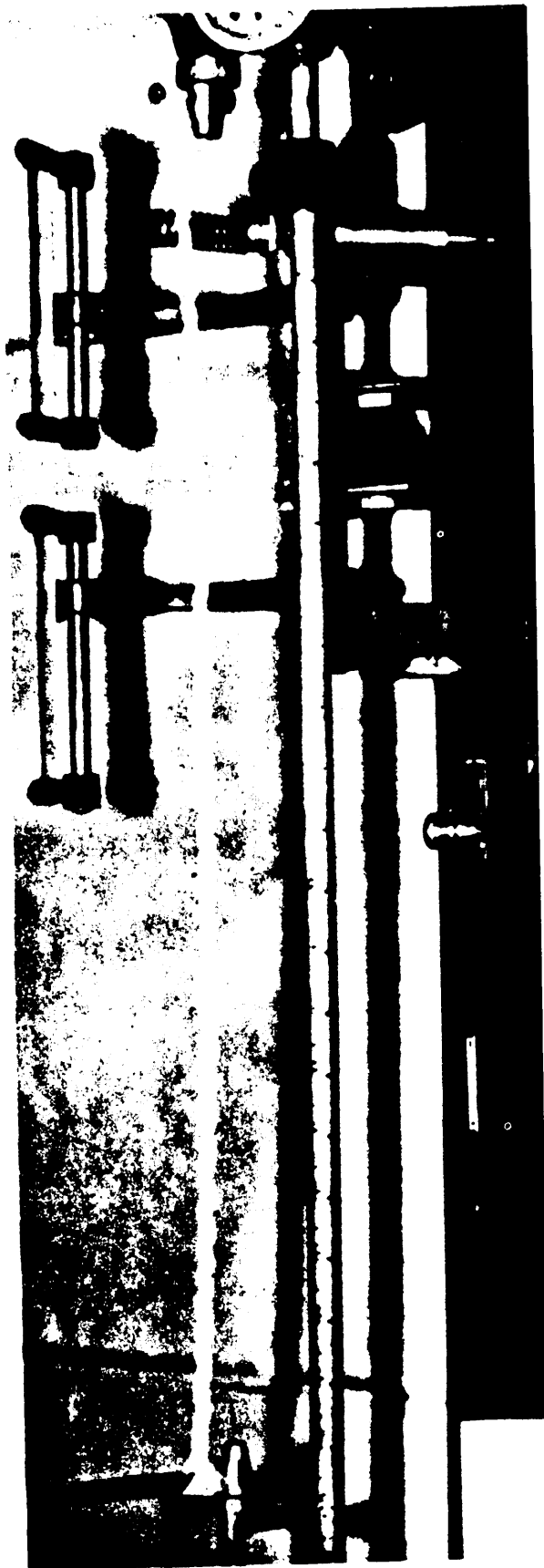

FIGURE 4502B - SKEIN WITH TWIST INSERTED

METHOD 4502

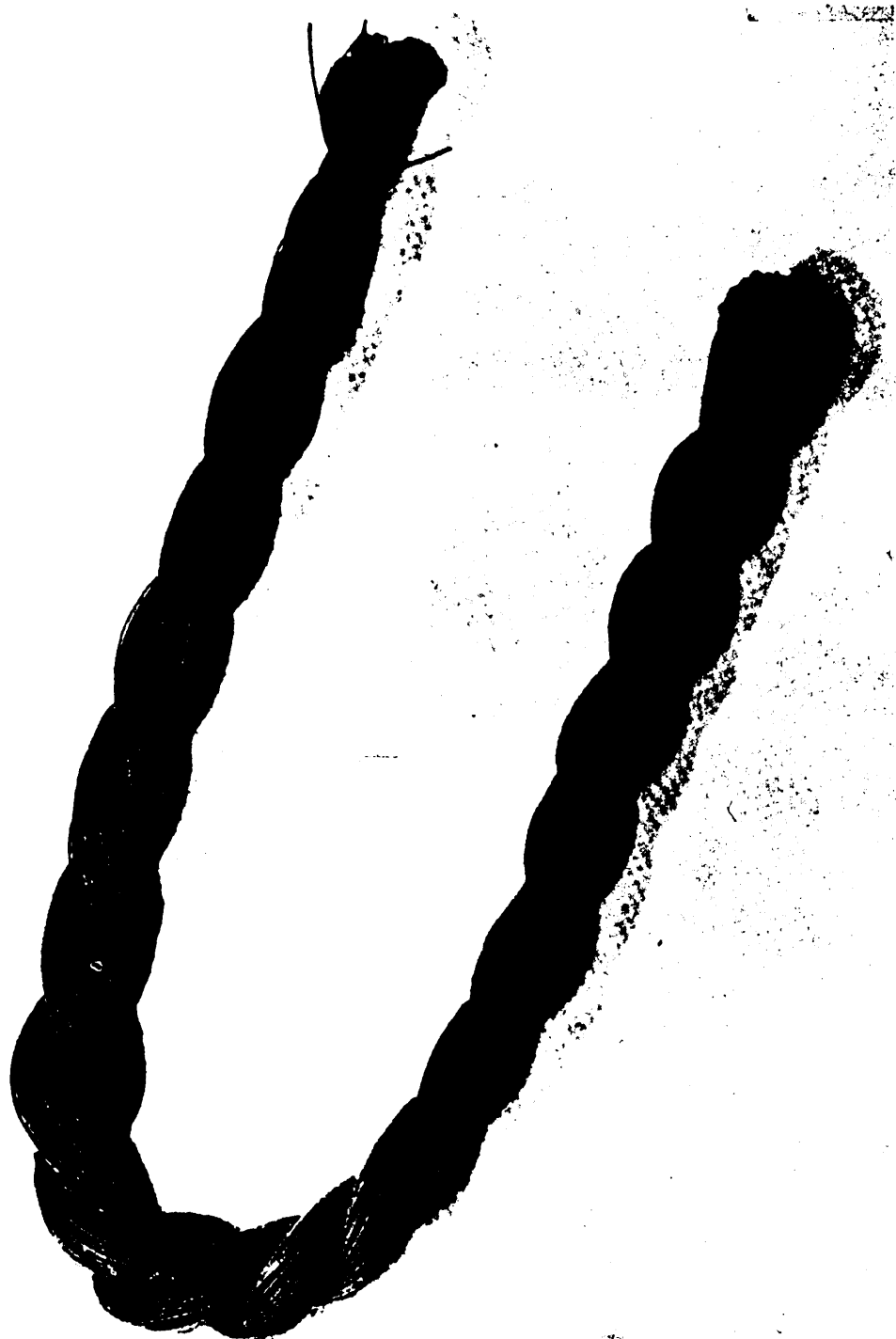

FIGURE 4.502C - FOLDED SKEIN

FED. TEST METHOD STD. NO. 191A

WATER RESISTANCE, VERTICAL RISE WICKING, THREAD

1. SCOPE

1.1 This method is intended for determining the resistance of thread to wicking of water under static conditions.

2. TEST SPECIMEN

2.1 The specimen shall be a twenty strand skein of thread prepared as specified in 5.1.

3. NUMBER OF DETERMINATIONS

3.1 Unless otherwise specified in the procurement document, two specimens shall be tested from each sample unit; one specimen shall be from the beginning and the other from the end of the sample unit.

4. APPARATUS

4.1 Water tank. Vessel capable of holding a minimum 6 inch (152 mm) depth of water.

4.2 Laboratory stand. Laboratory stand with movable crossbar rising 28 inches (711 mm) or more above the base.

4.3 Weight. Weight, nonferrous, 3/4 to 7/8 ounce (21 g to 25 g).

4.4 Dye. Dye-Basic Blue 9, color index 52015, salt and wetting agent free.

4.5 Blotting paper. The blotting paper shall be approximately 1 inch (25 mm) square (see 7.1).

4.6 Yarn reel. A 54-inch (1.37 m) periphery skein reel or other suitable device for preparing the specimen.

4.7 Distilled water.

4.8 Paper clip or similar clamp.

METHOD 4504

5. PROCEDURE

5.1 Preparation of specimen. The test specimen shall consist of a twenty strand skein of thread in one continuous 30 yard (27.4 m) length made on a 54-inch (1.37 m) periphery skein reel. The skein shall be reeled under enough tension to cause the strands in the skein to lie uniformly, side by side, on the reel. The finishing end of the skein shall be tied to the starting end of the skein in such a manner that the knot will not add additional length to the reel skein.

5.2 Unless otherwise specified in the procurement document, all tests shall be performed on material conditioned as specified in Section 4 of this Standard.

5.3 The skein shall be hung over the crossbar of the laboratory stand with the other end hanging over the vessel. The weight shall be placed in the lower catenary of the skein to keep it taut and straight. The skein shall be arranged so that the strands are touching each other in flat ribbon form. The vessel shall be filled to a depth of at least 5 inches (127 mm) with distilled water at room temperature which has been mixed with 0.05 percent dye.

5.4 A piece of blotting paper shall be attached by means of a paper clip or similar clamp to one strand of the skein, 3 inches (76 mm) above the lower catenary of the skein.

5.5 The position of the crossbar shall be so adjusted that when the skein is hung freely in the liquid, two inches of the skein will be immersed in the liquid and the lower edge of the blotter is 1 inch (25 mm) above the liquid surface.

5.6 The skein shall then be slowly lowered into the dyebath (see 5.5) and the time of entry shall be noted (see figure 4504).

5.6.1 Depending on the dimensions of the vessel and the length of the crossbar, several specimens can be tested at the same time in the same dyebath, by hanging the skeins sufficiently apart on the crossbar.

5.7 The skein shall be exposed for 6 hours. The blotter shall be examined for wetting or staining at least once every hour.

5.8 The test shall be terminated whenever staining or wetting of the blotter is observed, within the 6 hour test duration (see figure 4504).

6. REPORT

6.1 Unless otherwise specified in the procurement document, the resistance of thread to wicking of water shall be reported as "Satisfactory" (no staining or wetting of the blotter in the 6 hour exposure for all specimens), or "Unsatisfactory" (staining or wetting of the blotter within the 6 hour exposure for one or more specimens).

7. NOTES

7.1 The blotting paper is available from: James River Paper Company, P.O. Box 2218. Richmond, VA 23217.

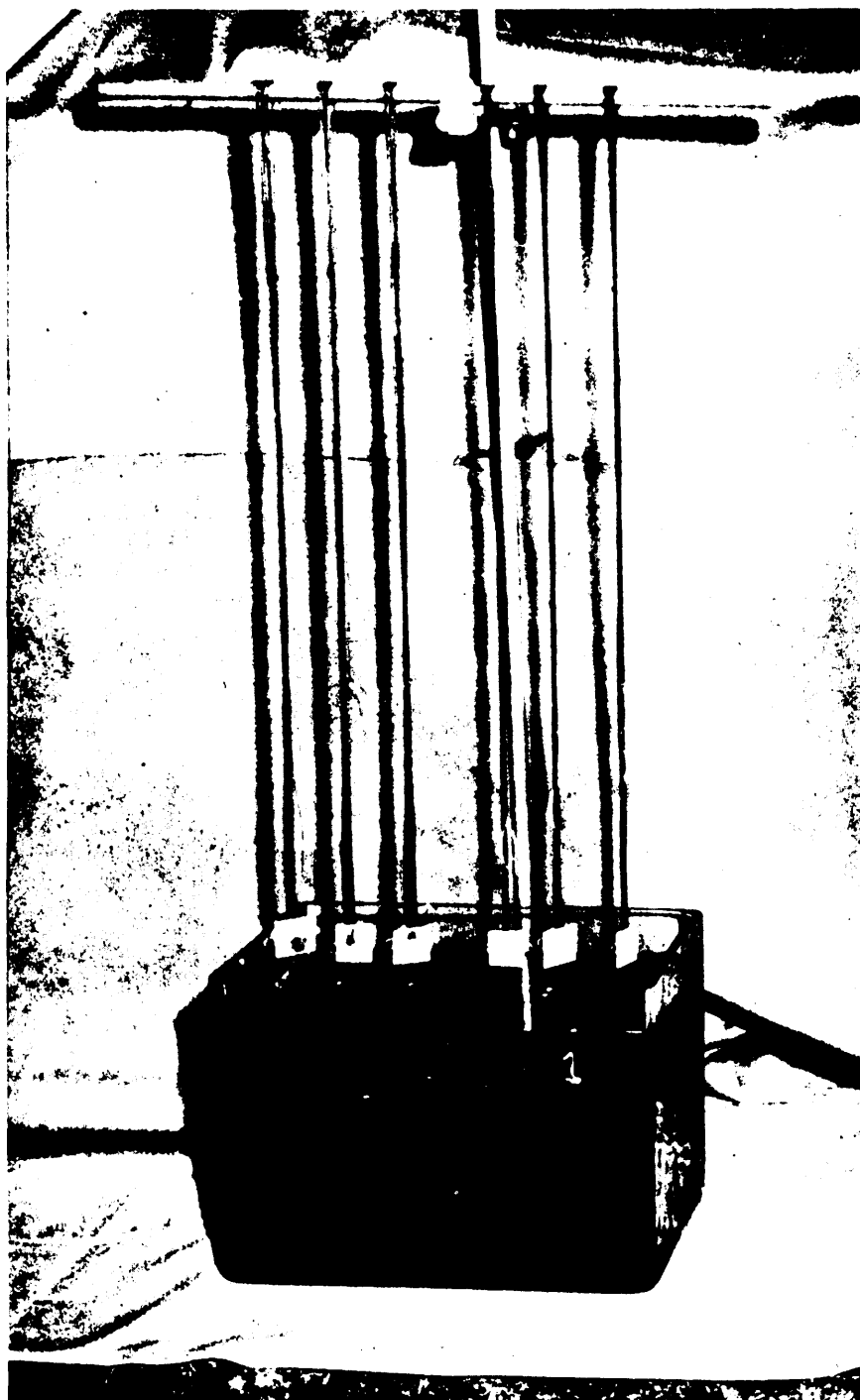

FIGURE 4504 Wicking of Water

METHOD 4800
July 20, 1978

WEATHERING RESISTANCE; YARN, CORDAGE;

NATURAL WEATHERING METHOD

1. SCOPE

1.1 This method is intended for determining the resistance to deterioration of cordage when subjected to a prolonged outdoor exposure. It is applicable to yarn, thread, and all other cordage of any kind. This method is not suitable for use in measuring the color fastness to natural weathering (see Method 5672).

2. TEST SPECIMEN

2.1 The specimen shall be of such form and dimension to provide the material required in the specified evaluation tests.

2.1.1 Yarns and small cordage may be prepared in skein form.

3. NUMBER OF DETERMINATIONS

3.1 The number of specimens tested from each sample unit shall be as required in the procurement document.

4. APPARATUS AND METHOD CITED

4.1 Apparatus.

4.1.1 The apparatus shall be as described in Method 5800.

4.2 Method cited.

Method 5672, Colorfastness to Weather of Textile Materials; Natural
Weathering Method

Method 5800, Weathering Resistance of Cloth; Natural Weathering Method

5. PROCEDURE

5.1 The procedure shall be as described in Method 5800 except for the following:

5.101 Heavy cordage or rope specimens. Heavy cordage or rope specimens shall be laid on the rack with the lengthwise direction parallel to the inclined position (from top to bottom direction). The specimen shall be held in place at the ends by any suitable means. If the specimen is spliced for test before exposure, the splice shall be protected from radiation and weather.

FED. TEST METHOD STD. NO. 191A

METHOD 4800

5.1.2 Yarn and light cordage specimens. Yarn and other cordage specimens may be mounted in the form of skeins, each skein containing sufficient material for conducting the required evaluation tests.

6. REPORT

6.1 The location of the exposure, town and state, and whether or not the area is nonindustrial shall be reported.

6.2 The specific dates and duration of the exposure period or the total radiation in langleys (g cal/cm^2) shall be reported.

6.3 Standard sample. Unless otherwise specified in the procurement document, when a standard sample has been established, resistance to weathering shall be reported as "Satisfactory" or "Unsatisfactory".

6.4 No standard sample. Unless otherwise specified in the procurement document, when a standard sample has not been established, change in breaking strength or other characteristic shall be reported to the nearest 1.0 percent.

METHOD 4804
July 20, 1978

WEATHERING RESISTANCE; YARN, THREAD, CORDAGE;

ACCELERATED WEATHERING METHOD

1. SCOPE

1.1 This method is intended for determining the resistance to deterioration of cordage when subjected to an accelerated weathering exposure. It is applicable to yarn, thread, and other cordage of all kinds.

2. TEST SPECIMEN

2.1 The specimen shall be of sufficient yardage to meet the requirements of the specified evaluation tests. Yarns and threads shall be wound open and with only slight tension on plastic panels or other suitable means for holding the strands side by side.

3. NUMBER OF DETERMINATIONS

3.1 The number of specimens tested from each sample unit shall be as required in the procurement document.

4. APPARATUS AND METHODS CITED

4.1 Apparatus.

4.1.1 The apparatus shall be as described in Method 5804 except that for heavy cordage and rope it has been found convenient to have a rack built above the weathering unit for attaching the specimen during exposure.

4.2 Methods cited.

Method 4100, Strength and Elongation, Breaking; and Tenacity; of Thread
and Yarn; Single Strand

Method 6016, Strength and Elongation, Breaking of Cordage; Non-Spliced
Specimen Method

Method 6015, Strength and Elongation, Breaking of Cordage; Spliced
Specimen Method

Method 5804, Weathering Resistance of Cloth; Accelerated Weathering Method

5. PROCEDURE

5.1 The procedure shall be as described in Method 5804 except for the following:

METHOD 4804

5.1.1 Light cordage. Light cordage specimens shall be tied or otherwise fastened loosely and suspended in the clamp. Care shall be taken that the specimen is not damaged in mounting and that there is no overlapping during the exposure.

5.1.2 Heavy cordage and rope. If breaking strength is used to measure the deterioration, approximately 24 Inches (610 mm) of the middle portion only of the specimen shall be exposed to radiation from the arc. This may be done by attaching the ends of the specimen to a rack above the arc in such a manner that they are protected from the light and that the middle two front portions of the specimen in the form of a loop are exposed to the radiation. If a spliced specimen (Method 6015) is exposed, the end of the splice shall be protected from the light.

5.1.3 Breaking strength, if required, shall be determined as described in Method 4100 for yarn and thread, as in Method 6016 for light cordage, and as in Method 6015 for heavy cordage and rope.

5.1.4 Calculation of results. The results shall be calculated as described in Method 5804.

6. REPORT

6.1 The number of hours of exposure or the required end point of exposure shall be reported.

6.2 Exposure unprotected by filters shall be reported.

6.3 The location of the exposure, town and state, and whether or not the area is nonindustrial shall be reported.

6.4 The specific dates and duration of the exposure period or the total radiation in langley (g cal/cm²) shall be reported.

6.5 Standard sample. Unless otherwise specified in the procurement document, when a standard sample has been established, resistance to weathering shall be reported as "Satisfactory" or "Unsatisfactory".

6.6 No standard sample. When required, and if not specified in the procurement document, when a standard sample has not been established, change in breaking strength shall be reported to the nearest 1.0 percent.

METHOD 4830
July 20, 1978

LEACHING RESISTANCE; CORDAGE; STANDARD METHOD

1. SCOPE.

1.1 This method is intended for leaching cordage at room temperature. This method is applicable to yarn, thread, cordage, and webbing which are to be subjected to the mildew resistant methods, group 5700.

2. TEST SPECIMEN

2.1 The specimen shall have the dimensions required for the subsequent evaluation test specified in the procurement document.

3. NUMBER OF DETERMINATIONS

3.1 The number of test specimens required from each sample unit shall be as specified in the subsequent evaluation test.

4. APPARATUS AND METHOD CITED

4.1 Apparatus.

4.1.1 Apparatus as described in Method 5830.

4.2 Method cited.

Method 5830, Leaching Resistance of Cloth; Standard Method.

5. PROCEDURE

5.1 The procedure shall be that described in Method 5830.

6. REPORT

6.1 The report shall be as provided for in the procurement document.

METHOD 4832
July 20, 1978

LEACHING RESISTANCE; CORDAGE; PREWET SPECIMEN METHOD

1. SCOPE

1.1 This method is intended for leaching cordage which is difficult to wet-out at room temperature. This method is applicable to impregnated fire, water, weather, and mildew resistant yarn, thread, cordage, webbing, etc.

2. TEST SPECIMEN

2.1 The specimen shall have the dimensions required for the subsequent evaluation test specified in the procurement document.

3. NUMBER OF DETERMINATIONS

3.1 The number of test specimens required from each sample unit shall be as specified in the subsequent evaluation test.

4. APPARATUS AND METHODS CITED

4.1 Apparatus.

4.1.1 Apparatus as described in Method 5832, except that the water container shall allow a ratio of specimen to water of not less than 1 to 33 by weight.

4.2 Methods cited.

Method 5830, Leaching Resistance of Cloth; Standard Method
Method 5832, Leaching Resistance of Cloth; Prewet Specimen Method

5. PROCEDURE

5.1 The procedure shall be that described in Method 5832.

6. REPORT

6.1 The report shall be as provided for in the procurement document.

LENGTH OF TEXTILE MATERIALS; DETERMINATION OF

1. SCOPE

1.1 This method is intended for determining the length of a cut, roll, or bolt of material. The 6 procedures described herein are as follows:

Hand method	Folding method
Drum method	Paper tape method
Clock method	Weight method

2. TEST SPECIMEN

2.1 The test specimen shall be a cut, roll, or bolt of material, except for the weight method, where the specimen shall be approximately 1 linear yard taken from the cut, roll, or bolt.

3. NUMBER OF DETERMINATIONS

3.1 Unless otherwise specified in the procurement document, five specimens shall be tested from each sample unit.

4. APPARATUS

4.1 Hand method.

4.1.1 Measurement stick or metal tape. Yardstick, meterstick, metal tape, or other suitable measuring device graduated in increments of 1/8 inch (1 mm).

4.2 Drum method.

4.2.1 Motor-driven material measuring drum with a dial or counter geared to the drum and its calibration. The arc of contact between the drum and the material being measured shall be sufficient to prevent slippage, and be controlled by 1 or 2 free-running jockey rollers or other means set close to, but not touching the drum.

4.3 Clock method.

4.3.1 A clocking device attached to a machine equipped to measure continuous lengths of material, and so mounted that the movement of the material through the machine turns the 2 wheels of the clocking device. The wheels shall be identical and mounted 3 to 4 inches (76 to 102 mm) apart on a free-running common axle connected to the counting

METHOD 5010

mechanism. The surface of the wheels shall be approximately 1/2 inch (13 mm) wide and covered with cork or other suitable friction material, ground to a known circumference with a precision of ± 0.1 percent. The counting mechanism scale shall be calibrated to this circumference and graduated in yards (m) and eighths of yards (0.1 m).

4.4 Folding method.

4.4.1 Mechanical material folding device, equipped with a counter, which folds a known length of material at each stroke.

4.5 Paper tape method.

4.5.1 Thin paper measuring tape 1/4 to 1/2 inch (6 to 13 mm) in width and graduated in yards (m) and eighths of yards (0.1 m) and, when specified for lightweight materials, a device for transversing the paper tape once along the length of the roll of the material.

4.6 Weight method.

4.6.1 Weighing scales accurate to ± 0.25 percent.

4.6.2 Measurement stick or metal tape. Yardstick (meterstick), metal tape or other suitable measuring device graduated in increments of 1/16 inch (1 mm).

5. PROCEDURE

5.1 Unless otherwise specified in the procurement document, all tests shall be performed on material conditioned as specified in Section 4.

5.2 Unless otherwise specified in the procurement document, the length of material shall be determined by any one of the following procedures, except that the hand method shall be used in cases of dispute.

5.3 Hand method. This method measures material length under zero tension. It is applicable to all types of materials, and is the primary method to which all others are compared for establishing their accuracy and precision.

5.3.1 The material shall be placed flat, without tension, on a smooth horizontal surface at least 3 yards (2.7 m) in length. Using a suitable measuring device, and pins as markers, successive portions, each at least 3 yards (2.7 m) in length, shall be measured to the nearest 1/8 inch (1 mm), and the results totaled to give the length of the material.

5.4 Drum method. This method may be used for measuring the length of all types of materials, providing its accuracy is in agreement with the hand method.

METHOD 5010

5.4.1 The material shall be run over the measuring drum with just enough tension to keep it moving flat and true and to prevent any slippage. The total length shall be read from the dial or counter and recorded to the nearest 1/8 yard (0.1 m).

5.5 Clock method. This method may be used for measuring the length of all types of material, providing its accuracy is in agreement with the hand method. The tension on the material must be kept at a minimum, since material length measured by this method represents the total material length under whatever tension prevailed while the material was running through the machine.

5.5.1 The entire material length or lengths shall be run through the clocking device on the material measuring machine. The total material length shall be directly read from the counter, and recorded to the nearest 1/8 yard (0.1 m).

5.6 Folding method. This method may be used for measuring the length of soft uncoated materials weighing 6 ounces per square yard (203 g/m^2) or less. It may be used for heavier materials, providing its accuracy is in agreement with the hand method.

5.6.1 The material shall be run through the folding device while checking the length of individual folds at frequent intervals with a yardstick or other measuring device. The total length of the material shall be determined as the product of the length of each fold and the number of strokes required to fold the entire piece and recorded to the nearest 1/8 yard (0.1 m).

5.7 Paper tape method. This method may be used for woolen and worsted materials, but is applicable to most heavy materials. When specified for lightweight materials, use the device for traversing the paper tape once along the length of the roll of material.

5.7.1 When the roll of material is shipped with the measuring tape incorporated in it, the starting end of the tape shall be checked to see that it was folded so that the first graduation protrudes slightly from the end of the roll for easy reference. When so received, the length of the material shall be calculated between the starting and finishing graduations of the tape, and shall be recorded to the nearest 1/8 yard (0.1 m).

5.7.2 When the tape must be inserted in the roll, it shall be wound with a minimum of tension. The graduations on the starting end of the tape shall be considered to correspond with the zero or any other convenient mark on the tape. The excess tape shall be torn off after winding. The length of the material shall be recorded as the difference between the starting and finishing graduations on the tape to the nearest 1/8 yard (0.1 m).

METHOD 5010

5.8 Weight method. This method may be used for all materials, and requires that the weight of the cut, roll, or bolt and that of the 1-linear yard specimen be determined on a conditioned basis.

5.8.1 Calculation of results. The cut, roll, or bolt and the 1-linear yard specimen shall be weighed to the nearest 0.01 percent of the weight of each. The length of the cut, roll, or bolt shall be calculated to the nearest 1/8 yard (0.1 m), as follows:

Length of cut, roll, or bolt in yards =

$$\frac{\text{Weight of cut, roll, or bolt in pounds} \times \text{length of specimen in yards}}{\text{Weight of specimen in pounds}}$$

Length of cut, roll or bolt in m = Length of cut, roll or bolt in
yards x 0.91

6. REPORT

6.1 The method used in the determination of length shall be reported, and, when required, its agreement in accuracy with that of the hand method.

6.2 The length of the sample unit shall be the average of the results obtained from the specimens tested, and shall be reported to the nearest 1/8 yard (0.1 m).

6.3 Each individual value used to calculate the average shall also be reported.

METHOD 5020
July 20, 1978

WIDTH OF TEXTILE MATERIALS; DETERMINATION OF

1. SCOPE

1.1 This method is intended for determining the width of textile materials. Three procedures are described:

- a. short specimen method
- b. full roll method
- c. piece method

2. TEST SPECIMEN

2.1 Short-specimen method. The test specimen shall be a full width piece of material at least 1 yard (1 m) in length cut no less than 1 yard (1 m) from the ends of the bulk material.

2.2 Full roll method. The test specimen shall be the full length of the roll.

2.3 Piece method. The test specimen shall be the number of pieces of material constituting a roll.

3. NUMBER OF DETERMINATIONS

3.1 Short-specimen method. Unless otherwise specified in the procurement document, five specimens shall be tested from each sample unit.

3.2 Full roll method. Unless otherwise specified in the procurement document, one specimen (5 measurements) shall be tested from each sample unit.

3.3 Piece method. Unless otherwise specified in the procurement document, one specimen (5 measurements per piece) shall be tested from each sample unit.

4. APPARATUS

4.1 Measuring stick or metal tape. Yardstick, meterstick or metal tape graduated in increments of 1/32 inch (1 mm).

5. PROCEDURE

5.1 Unless otherwise specified in the procurement document, all tests shall be performed on material conditioned as specified in section 4.

FED. TEST METHOD STD. NO. 191A

METHOD 5020

5.2 The material shall be placed flat, without tension, on a smooth horizontal surface. The distance from edge to edge including selvage shall be measured in a line perpendicular to the lengthwise direction of the material. Care shall be taken that the measurement does not deviate from the perpendicular.

5.2.1 Wide materials. The measurement shall be made to the nearest 1/16 inch (1 mm) 1

5.2.2 Narrow materials, tapes, and ribbons. The measurement shall be made to the nearest 1/32 inch (1 mm).

5.3 Short-specimen method. One measurement shall be made no nearer the ends of the material than 6 inches (152 mm).

5.4 Full roll method. Five measurements shall be made no nearer the ends of the material than 1 yard (1 m).

5.5 Piece method. Five measurements shall be made on the piece no nearer the ends of the material than 6 inches (152 mm).

6. REPORT

6.1 The width of the sample unit shall be the average of the results obtained from the specimens tested and shall be reported to the nearest 1/16 inch (1 mm) for wide materials and the nearest 1/32 inch (1 mm) for narrow materials, tapes, and ribbons.

6.2 Each individual measurement used to calculate the average shall also be reported.

METHOD 5030
July 20, 1978

THICKNESS OF TEXTILE MATERIALS; DETERMINATION OF

1. SCOPE

1.1 This method is intended for determining the thickness of woven and knitted cloths, nonwovens, felt, blankets, pile and napped cloths, narrow cloths, webbings, ribbons, braids, coated cloths, films, glass cloths and tapes.

2. TEST SPECIMEN

2.1 The specimen shall be a piece of material at least as large as the presser foot of the thickness gage, and shall be free of folds, creases, knots, or other distortions which are not representative of the material surface. When possible, no selvage shall be included in the sample tested. If the specimen is much larger than the anvil, the specimen shall be supported around the anvil and at the same height as the anvil to avoid distortion of the specimen, thereby raising the presser foot above its proper plane.

2.1.1 Narrow cloths and webbings. The specimen for narrow cloths and webbings shall be the full width of the material.

2.1.2 Ribbons and tapes. The specimen for ribbons and tapes, when one width of the material does not present a specimen as large as the presser foot, shall be several lengths of the material placed adjacent and parallel.

2.1.3 Films, glass cloths, and tapes. The specimen for films, glass cloths, and tapes shall be of sufficient size to insure that all points on the periphery of the presser foot shall be at least 1/4 inch (6 mm) from the edge of the specimen.

3. NUMBER OF DETERMINATIONS

3.1 Unless otherwise specified in the procurement document, five specimens shall be tested from each sample unit.

4. APPARATUS

4.1 Unless otherwise specified in the procurement document, the apparatus shall be as applicable.

METHOD 5030

4.1.1 Woven and knitted materials, felts, nonwovens. Gage of the dead-weight type equipped with a dial graduated to read directly to 0.001 inch (0.0254 mm). The presser foot shall be circular, with a diameter of 1.129 ± 0.001 inch ($28.6 \text{ mm} \pm 0.0254 \text{ mm}$) and with the moving parts connected therewith weighted to apply a total load of 0.60 ± 0.03 pound per square inch ($4.1 \pm 0.2 \text{ kPa}$) to the specimen. The anvil shall be not less than 1.129 inches (28.6 mm) in diameter. The presser foot and anvil surface shall be plane to within 0.0001 inch (0.00254 mm) and shall be parallel to each other to within 0.0001 inch (0.00254 mm).

4.1.2 Coated cloths, narrow cloths, webbings, ribbons and braids. Gage of the dead-weight type equipped with a dial graduated to read directly to 0.001 inch (0.0254 mm). The presser foot shall be circular with a diameter of $0.375 \text{ inch} \pm 0.001 \text{ inch}$ ($9.525 \text{ mm} \pm 0.0254 \text{ mm}$) and with the moving parts connected therewith weighted to apply a total load of 3.4 ± 0.1 pounds per square inch ($23.4 \pm 0.7 \text{ kPa}$) to the specimen. The anvil shall be not less than 1.129 inches (28.6 mm) in diameter. The presser foot and anvil surface shall be plane to within 0.0001 inch (0.00254 mm) and shall be parallel to each other to within 0.0001 inch (0.00254 mm).

4.1.3 Films, glass cloths, and tapes. Gage of the dead-weight type equipped with a dial graduated to read directly to 0.0001 inch (0.00254 mm). The presser foot shall be circular with a diameter of $0.250 \text{ inch} \pm 0.001 \text{ inch}$ ($6.350 \text{ mm} \pm 0.0254 \text{ mm}$), and with the moving parts weighted to apply a total load of 25 ± 2 pounds square inch ($172 \pm 14 \text{ kPa}$) to the specimen. The anvil shall be not less than 0.250 inch (6.350 mm) in diameter. The presser foot and anvil surface shall be plane to within 0.0001 inch (0.00254 mm) and shall be parallel to each other to within 0.0001 inch (0.00254 mm). The micrometer shall be capable of repeating its readings to 0.00005 inch (0.00127 mm) at zero setting or on a steel gage block.

4.1.4 Blankets, pile, or napped cloths. Gage of dead-weight type equipped with a dial graduated to read directly to 0.001 inch (0.0254 mm). The presser foot shall be circular with a diameter of 1.129 ± 0.001 inches ($28.6 \pm 0.0254 \text{ mm}$), and with the moving parts connected therewith weighted to apply separate total loads of 0.1 ± 0.01 pounds per square inch ($0.7 \pm 0.07 \text{ kPa}$) and 1.1 ± 0.03 pounds per square inch ($7.6 \pm 0.2 \text{ kPa}$) to the specimen. The anvil shall be not less than 1.129 inches (28.6 mm) in diameter. The presser foot and anvil surface shall be plane to within 0.0001 inch (0.00254 mm) and shall be parallel to each other to within 0.0001 inch (0.00254 mm).

5. PROCEDURE

5.1 Unless otherwise specified in the procurement document, all tests shall be performed on material conditioned as specified in Section 4.

METHOD 5030

5.2 All materials except films. The specimen shall be placed face up on the anvil of the gage, smoothly, but without tension. The presser foot shall be lowered onto the specimen gradually and without impact, and allowed to rest there for 10 seconds. The dial reading shall then be taken to the nearest 0.001 inch (0.0254 mm).

5.2.1 Narrow cloths and webbings. The readings for narrow cloths and webbings shall be taken along the centerline of the specimen.

5.3 Films, glass cloths and tapes. The specimen shall be placed between the micrometer surfaces, and the presser foot lowered onto the specimen at a location outside the area to be measured. The presser foot shall be raised a distance of 0.0003 to 0.0004 inches (0.0076 to 0.0102 mm), the specimen moved to the measurement position, and the presser foot then dropped onto the specimen. The presser foot shall then be allowed to rest there for a minimum of 5 seconds. The dial reading shall then be taken to the nearest 0.0001 inch (0.00254 mm).

6. REPORT

6.1 All materials except film, glass cloth and tapes. The thickness of the sample unit shall be the average of the results obtained from the specimens tested, and shall be reported to the nearest 0.001 inch (0.0254 mm).

6.2 Films, glass cloth, tapes. The thickness of the sample unit shall be the average of the results obtained from the specimens tested, and shall be reported to the nearest 0.0001 inch (0.00254 mm).

6.3 Each individual value used to calculate the average shall also be reported.

7. NOTES

7.1 Apparatus of the type described in this method may be obtained from:

- (a) B. C. Ames Co., Lexington Street, Waltham, MA 02154
- (b) Custom Scientific Instruments, Inc., 13 Wing Drive, Whippany, NJ 07981.
- (c) Federal Products Corp., 1144 Eddy Street, Providence, RI 02901.
- (d) Frank E. Randall Co., 248 Ash Street, Waltham, MA 02154.
- (e) Testing Machines, Inc., 400 Bayview Avenue, Amityville, Long Island, NY 11701.
- (f) Frazier Precision Instrument Co., Inc., Silver Spring, MD 20907.
- (g) American Instrument Co., 8030 Georgia Avenue, Silver Spring, MD 20910.

WEIGHT OF CLOTH; CUT, ROLL, OR BOLT METHOD; DETERMINATION OF

1. SCOPE

1.1 This method is intended for determining the unit weight of cloth from the weight and area of the whole unit. Three procedures are described:

- a. The piece, cut, roll, or bolt method
- b. The full width short specimen method
- c. The narrow cloth method

Since selvages are included, it is representative of the bulk cloth. Weight may be expressed in ounces per square yard (g/m^2), ounces per linear yard (g/m) or linear yards per pound (m/kg).

2. TEST SPECIMEN

2.1 Piece, cut, roll, or bolt method. The test specimen shall be a full-piece cut, roll, or bolt of cloth.

2.2 Full width short-specimen method. The test specimen shall be a full width piece of cloth at least 1/4 yard (230 mm) in length, cut, not torn, from the bulk cloth. To insure the length of the specimen is the same across the width of the specimen, the trimming shall be guided by following a single filling thread.

2.3 Narrow cloth method. The test specimen shall be three full width 1-yard (1 m) lengths of narrow cloth accurately cut from the bulk cloth at right angles to the selvages, taken from evenly spaced places along the length of the bulk cloth.

3. NUMBER OF DETERMINATIONS

3.1 Unless otherwise specified in the procurement document, one specimen shall be tested from each sample unit.

4. APPARATUS AND METHODS CITED

4.1 Apparatus.

4.1.1 Measurement stick or metal tape. Yardstick, meterstick, metal tape or other suitable measuring device graduated in increments of 1/16 inch (1 mm).

METHOD 5040

4.1.2 Balance. Balance or scale capable of weighing the specimen, to an accuracy of ± 0.01 g.

4.2 Methods cited.

Method 5010, Length of Textile Materials; Determination of
Method 5020, Width of Textile Materials; Determination of

5. PROCEDURE

5.1 Unless otherwise specified in the procurement document, the weight of the cloth shall be determined by the applicable procedure. Unless otherwise specified, all tests shall be performed on material conditioned as specified in Section 4 of this Standard.

5.2 Piece, cut, roll, or bolt method. The full piece, cut, roll, or bolt shall be measured for length and width at zero tension by applicable procedure described in Methods 5010 and 5020. The specimen shall then be weighed to the nearest ± 0.01 g of its weight. The weight shall be obtained on a non-conditioned basis, as there is no practical way of obtaining equilibrium of this volume of cloth under standard conditions.

5.3 Full width short-specimen method. The specimen shall be measured for length and width at zero tension by the applicable procedure described in Methods 5010 and 5020. The specimen shall then be weighed to the nearest 0.01 percent of its weight.

5.4 Narrow cloth method. Each of the three lengths of the specimen shall be remeasured at zero tension to the nearest 1/16 inch (1 mm). The specimen shall then be weighed to the nearest 0.01 percent of its weight.

5.5 Calculation of results.

5.5.1 Piece, cut, roll, or bolt method. The weight shall be calculated by one of the following methods:

$$\text{Ounces per square yard} = \frac{\text{Weight (lb.)} \times 576}{\text{Length (yd.)} \times \text{width (in.)}}$$

$$\text{g/m}^2 = \frac{\text{Weight (kg)} \times 1\,000\,000}{\text{Length (m)} \times \text{width (mm)}}$$

$$\text{Ounces per linear yard} = \frac{\text{Weight (lb.)} \times 16}{\text{Length (yd.)}}$$

$$\text{g/m} = \frac{\text{Weight (kg)} \times 1000}{\text{Length (m)}}$$

$$\text{Linear yards per pound} = \frac{\text{Length (yd)}}{\text{Weight (lb.)}}$$

$$\text{m/kg} = \frac{\text{Length (m)}}{\text{Weight (kg)}}$$

5.5.2 Full width short-specimen method. The weight shall be calculated by one of the following methods:

$$\text{Ounces per square yard} = \frac{\text{Weight (g)} \times 45.72}{\text{Length (in.)} \times \text{width (in.)}}$$

$$\text{g/m}^2 = \frac{\text{Weight (g)} \times 1\,000\,000}{\text{Length (mm)} \times \text{width (mm)}}$$

$$\text{Ounces per linear yard} = \frac{\text{Weight (g)} \times 1.27}{\text{Length (in.)}}$$

$$\text{g/m} = \frac{\text{Weight (g)} \times 1000}{\text{Length (mm)}}$$

$$\text{Linear yards per pound} = \frac{\text{Length (in.)} \times 12.60}{\text{Weight (g)}}$$

$$\text{m/kg} = \frac{\text{Length (mm)}}{\text{Weight (g)}}$$

5.5.3 Narrow cloth method. The weight shall be calculated by one of the following methods:

$$\text{Linear yards per pound} = \frac{\text{Total length of specimen (in.)} \times 12.60}{\text{Total weight of specimen (g)}}$$

$$\text{m/kg} = \frac{\text{Total length (mm)}}{\text{Total weight (g)}}$$

$$\text{Ounces per linear yard} = \frac{\text{Total weight (g)} \times 1.27}{\text{Total length (in.)}}$$

$$\text{g/m} = \frac{\text{Total weight (g)} \times 1000}{\text{Total length (mm)}}$$

METHOD 5040

6. REPORT

6.1 The weight of the sample unit shall be reported in the units specified in the procurement document, to the nearest 0.1 ounce per square yard (1 g/m^2), 0.1 ounce per linear yard (1 g/m), 0.1 linear yard per pound (m/kg).

6.2 Each individual value used in expressing the final result shall also be reported.

WEIGHT OF TEXTILE MATERIALS, SMALL SPECIMEN METHOD;

DETERMINATION OF

1. SCOPE

1.1 This method is intended for determining the weight of a textile material by using a small specimen.

2. TEST SPECIMEN

2.1 Unless otherwise specified in the procurement document, the specimen shall be a piece of material not less than 4 square inches (2580 mm²) in area, cleanly cut from the bulk material. Unless otherwise specified in the procurement document, no two specimens shall be taken from the areas containing the same wales and courses in knitted cloth or the same warp and filling yarns in woven cloth. No selvage shall be included in the sample tested.

2.1.1 Webbings, tapes, braids, and narrow cloths. When material is 1 inch (25 mm) or less in width, a full width sample 4 feet (1.2 m) in length shall be used. For materials 1 inch (25 mm) to 2 inches (51 mm) in width, a full width sample 2 feet (610 mm) in length shall be used.

3. NUMBER OF DETERMINATIONS

3.1 Unless otherwise specified in the procurement document, five specimens shall be tested from each sample unit.

4. APPARATUS

4.1 Analytical balance. Analytical balance capable of weighing the specimen to an accuracy of 0.01 g (see 7.1).

4.2 Symmetrical metal die for cutting the specimen from the material.

5. PROCEDURE

5.1 Unless otherwise specified, all tests shall be performed on material conditioned as specified in section 4 of this Standard.

METHOD 5041

5.2 The material shall be placed flat, without tension, on a smooth horizontal surface and the specimen cut cleanly from the material. The specimen shall be weighed to the nearest 0.01 g on an analytical balance or directly on a calibrated balance.

5.3 Calculation of results. The weight shall be calculated by one of the following methods, which shall be specified in the procurement document:

Ounces per square yard	=	$\frac{\text{Weight (g)} \times 45.72}{\text{Area of specimen (in.}^2\text{)}}$
g/m ²	=	$\frac{\text{Weight (g)} \times 1\,000\,000}{\text{Area of specimen (mm}^2\text{)}}$
Ounces per linear yard	=	$\frac{\text{Weight (g)} \times \text{width of material (in.)} \times 1.27}{\text{Area of specimen (in.}^2\text{)}}$
g/m	=	$\frac{\text{Weight (g)} \times \text{width of material (mm)} \times 1000}{\text{Area of specimen (mm}^2\text{)}}$
Linear yards per pound	=	$\frac{\text{Area of specimen (in.}^2\text{)} \times 12.60}{\text{Weight (g)} \times \text{width of material (in.)}}$
m/kg	=	$\frac{\text{Area of specimen (mm}^2\text{)}}{\text{Weight (g)} \times \text{width of material (mm)}}$

6. REPORT

6.1 The weight of the sample unit shall be the average of the results obtained from the specimens tested, and shall be reported in the units specified in the procurement document to the nearest 0.1 ounce per square yard (1 g/m²), 0.1 ounce per linear yard (1 g/m), 0.1 linear yard per pound (m/kg).

6.2 Each individual value used to calculate the average shall also be reported.

7. NOTES

7.1 Direct reading balance. As an alternate, a direct reading balance calibrated to give the weight in ounces per square yard (g/m²) or ounces per linear yard (g/m) may be used. The balance shall be capable of reading to the nearest 0.05 ounce (1 g).

Method 5050
July 20, 1978

YARNS PER UNIT LENGTH (INCH OR CENTIMETER)

IN WOVEN CLOTH

1. SCOPE

1.1 This method is intended for determining the number of warp and filling yarns per unit length (inch or centimeter) in woven cloths, narrow cloths, tapes, and webbings.

2. TEST SPECIMEN

2.1 The specimen shall be a piece of cloth of sufficient size to permit the counting of yarns per unit length in the applicable procedure. Unless otherwise specified, no selvage shall be included in the sample tested nor shall the same yarns be included in any two determinations.

3. NUMBER OF DETERMINATIONS

3.1 Unless otherwise specified in the procurement document, five specimens shall be tested in each of the warp and filling directions from each sample unit when procedures specified in 5.3.1 and 5.3.2 are required, and one specimen in the warp and five specimens in the filling from each sample unit when procedures in 5.3.3 and 5.3.4 are required.

3.1.1 Unless otherwise specified in the procurement document, when tape or webbing is tested, one specimen for warp ends, binder warp ends, and stuffer warp ends, and five specimens for filling ends shall be tested from each sample unit.

4. APPARATUS

4.1 Counting devices. Pick glass, ruler and pointer, projection equipment, or other suitable form of counting device.

5. PROCEDURE

5.1 Unless otherwise specified, all tests shall be performed on material conditioned as specified in section 4.

5.2 The following procedures involve the counting of the number of yarns constituting the cloth construction. This is accomplished by determining the number of yarns while under magnification to facilitate counting. There

METHOD 5050

is a range of apparatus available, but all basically constitute a degree of magnification of the cloth and some type of marked and measured distance to within the field of view to measure the yarns found in a specific distance as the measure of the cloth texture. Especially in dark colored and finely woven cloth, the placing of the cloth specimen over a light source to highlight the cloth construction facilitates counting.

5.3 Yarns per unit length, warp. The cloth shall be placed as flat as possible, without tension, on a smooth horizontal surface. The actual number of warp yarns shall be counted as specified by the applicable procedure.

5.3.1 Cloths having 25 yarns per inch (10 yarns/cm) or more. The number of warp yarns in 1 inch (25 mm) of cloth width shall be counted.

5.3.2 Cloths having less than 25 yarns per inch (10 yarns/cm). The number of warp yarns in a 3-inch (76 mm) cloth width shall be counted and the number of yarns per inch (yarns/cm) determined to the nearest whole yarn.

5.3.3 Cloths less than 3 inches (76 mm) in width. All warp yarns including selvage shall be counted. The number of yarns per inch (yarns/cm) shall be determined to the nearest whole yarn by dividing the total number of warp yarns by the actual width of the cloth.

5.3.4 Closely woven cloths and those having a fancy weave. The yarns in a 1-inch (25 mm) or larger, as specified, strip specimen shall be raveled to facilitate counting. For closely woven cloths, the number of warp yarns raveled from a 1-inch (25 mm) strip of cloth shall be counted. For fancy weaves, where the number of yarns in either direction may be irregular, the yarns shall be counted over one full-pattern repeat. For tapes and webbings, warp ends, binder warp ends, and stuffer warp ends shall be counted and reported separately per inch (/cm), or as specified in the procurement document. The size of the pattern repeat, size of the design component, and the total yarns in each component shall be recorded.

5.4 Yarns per unit length, filling. The number of yarns per inch (yarns/cm) in the filling direction shall be determined as specified in 5.3.

5.4.1 When the cloth size is insufficient for determinations as specified above, the areas for counting yarns per inch (yarns/cm) shall be selected to include as many shuttle changes as possible.

6. REPORT

6.1 The number of yarns per unit length of the sample unit shall be the average of the results obtained from the specimens tested in each of the warp and filling directions, and shall be reported separately to the nearest whole number of yarns.

6.1.1 When fancy-weave cloths are tested, unless otherwise specified in the procurement document, the following shall be reported:

- a. Size of pattern repeat
- b. Size of design component
- c. Total number of yarns in each component

6.2 Each individual value used to calculate the average shall also be reported.

STITCHES PER UNIT LENGTH IN SEAMS AND STITCHINGS; DETERMINATION OF

1. SCOPE

1.1 This method is intended for determining the number of stitches in a specified length for either straight line or zig-zag stitches.

2. TEST SPECIMEN

2.1 Unless otherwise specified in the procurement document, the specimen shall be a row of stitches measuring 3 inches or 10 centimeters in length.

2.2 When a row of stitches is longer than 3 inches or 10 cm, the number of stitches (or perforations in zig-zag-stitches), shall be counted along a 3-inch or 10 cm length and the count divided by 3 or 10 to represent the average stitches per inch or stitches per cm in the specimen.

2.3 When a row of stitches is less than 3 inches or 10 cm in length, the entire row of stitches (or perforations in zig-zag stitches), shall be the specimen.

2.4 Stitches along a curved length. When the specimen row of stitches follows a curve, the tune shall not be straightened out, but the stitches shall be counted around the curve. The distance counted shall be measured around the curve as specified in 2.2 and 2.3, by means of a flexible tape or other accurate means.

3. NUMBER OF DETERMINATIONS

3.1 Unless otherwise specified in the procurement document, one specimen shall be tested from each row of stitches designated to be tested.

4. APPARATUS

4.1 Ruler. A ruler or flexible steel tape graduated in increments of 1/16 inch (1 mm).

4.2 Magnifying glass. A magnifying glass or similar device.

4.3 Pointer. A fine needle, or similar device used to count stitches.

METHOD 5052

5. PROCEDURE

5.1 Unless otherwise specified, testing shall be performed under prevailing atmospheric conditions.

5.2 The row of stitches to be counted shall be laid as flat as possible on a horizontal surface, without tension, and the specimen marked and measured by beginning at the center of a sewing needle perforation.

5.3 Using the magnifying glass and pointer, count the total number of stitches (see 7.1.1) by using the following criteria:

5.3.1 Straight line stitches. The number of stitches in a row of straight line stitches shall be counted as follows: Mark off the specimen length, placing the first mark on the center of a needle perforation. Beginning at the needle perforation following the first mark, count all the needle perforations in the specimen. If any portion of the stitch unit (see 7.1.2) following the last perforation, falls within the specimen length, that float (see 7.1.3), shall be counted as an additional perforation.

5.3.2 Zig-zag stitches. The number of stitches in a row of zig-zag stitching shall be counted as follows: Mark off the specimen length placing the first mark on the center of a needle perforation. Beginning at the needle perforation following the first mark, count all the needle perforations along the zig-zag pattern in the specimen. If any portion of the stitch unit (see 7.1.2) following the last perforation, falls within the specimen length, that float (see 7.1.3) shall be counted as an additional perforation.

5.3.3 Multiple needle machine sewing. When the stitches of multiple needle sewing around a curve are counted, the row made by the outside needle shall be counted.

5.4 Calculation.5.4.1 For straight line stitching and zig-zag stitching.

$$\text{Stitches per unit length} = \frac{\text{Total No. of needle perforations}}{\text{Specimen length}}$$

6. REPORT

6.1 The average stitches per unit length shall be reported to the nearest whole number.

7. NOTES

7.1 Definitions.

7.1.1 Stitch. A stitch is the unit of linkage formed by the intra-looping a thread with itself or interlooping with one or more other threads.

7.1.2 Stitch unit. A stitch unit is one complete repeat of a float and stitch.

7.1.3 Float. A float is that section of thread laying between two needle perforations, on the top side of the cloth as observed during the sewing operation.

BOW OF YARNS IN WOVEN CLOTH

1. SCOPE

1.1 This method is intended for determining the bow of yarns in woven cloth, that is, the extent to which the filling yarns do not lie in a straight line from selvage to selvage. It is also applicable to dyed, finished, and coated cloth.

2. TEST SPECIMEN

2.1 The specimen shall be a full width piece of cloth at least one yard (1 m) in length, cut, not torn, from a cut, roll, or bolt, a minimum of one yard (1 m) from either end, or the full length of a roll or piece of cloth.

3. NUMBER OF DETERMINATIONS

3.1 Unless otherwise specified in the procurement document, three specimens shall be tested from each sample unit.

4. APPARATUS

4.1 Measurement stick or metal tape. Yardstick, meterstick, metal tape, or other suitable measuring device graduated in increments of 1/16 inch (1 mm) for measuring the width of the cloth.

4.2 Rigid straightedge.

5. PROCEDURE

5.1 Unless otherwise specified in the procurement document, all tests shall be performed on material conditioned as specified in Section 4.

5.2 The cloth shall be placed flat, without tension, on a smooth horizontal surface. The position of a filling yarn in a cloth shall be marked across the full width of the cloth, or a colored filling yarn may be selected when these are distinctive and woven at intervals into the cloth.

5.3 A rigid straightedge shall be placed across the cloth between the points at which the marked or colored filling yarn meets the two selvages, and a straight line drawn connecting the two. This width shall be measured to the nearest 1/16 inch (1 mm).

METHOD 5060

5.4 The greatest distance parallel to the selvages between the drawn line and the marked or colored filling yarn shall be measured to the nearest 1/16 inch (1 mm). This measurement shall be designated the bow.

5.5 Calculation of results. The bow shall be calculated as follows:

$$\text{Bow, percent} = \frac{D}{W} \times 100$$

Where: D = greatest distance measured to the nearest 1/16 inch (1 mm) between the marked filling yarn and the drawn line.

W = width of the cloth in inches (mm).

6. REPORT

6.1 The bow of the sample unit shall be the average of the results obtained from the specimens tested, and shall be reported to the nearest 0.5 percent.

6.2 Each individual value used to calculate the average shall also be reported.

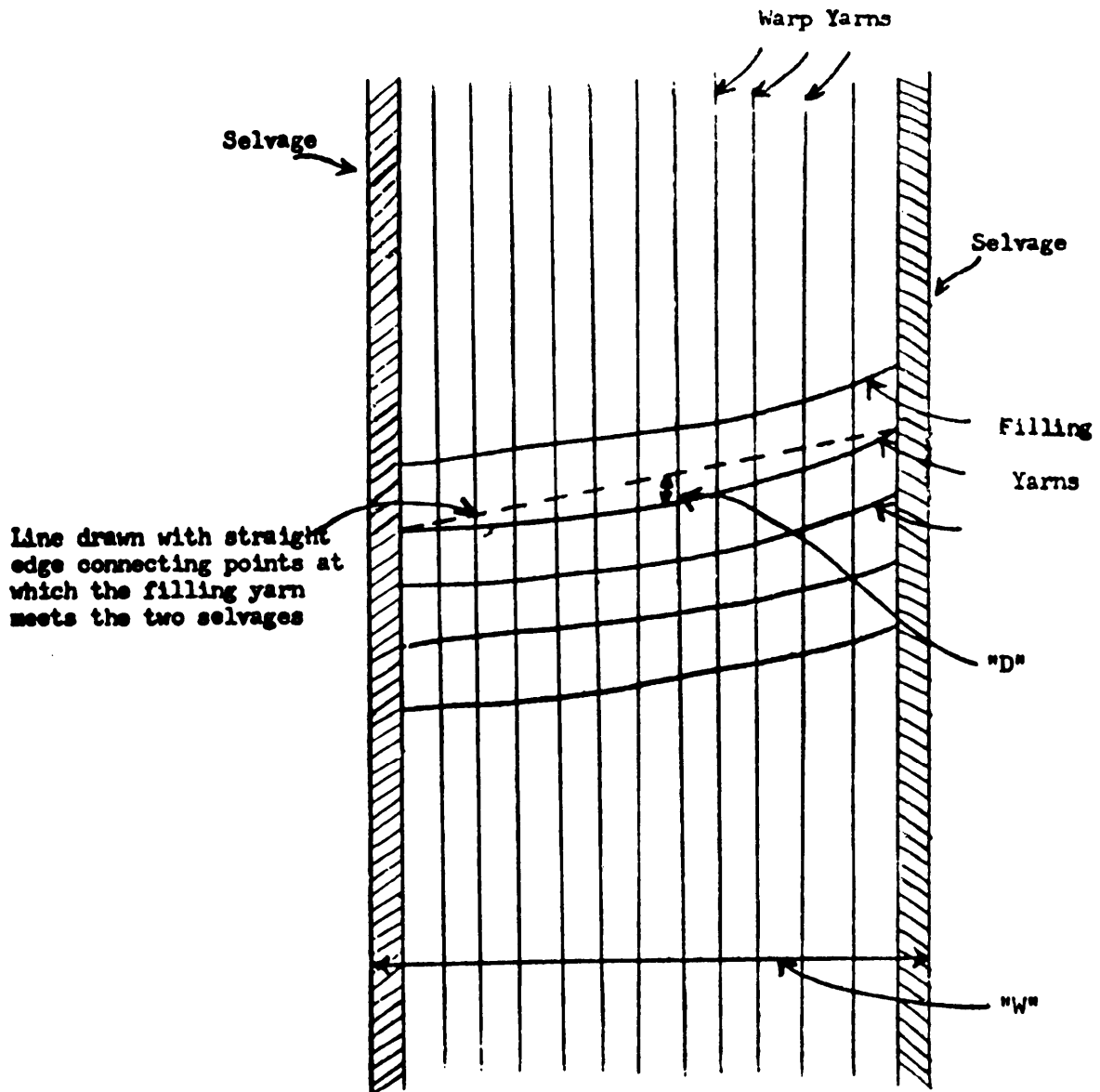

FIGURE 5060 Example - Bow measurement.

WALES AND COURSES IN KNIT CLOTH

1. SCOPE

1.1 This method is intended for determining the number of wales and courses per inch (wales and courses per cm) in knit cloth.

2. TEST SPECIMEN

2.1 The specimen shall be a piece of cloth measuring at least two inches by two inches (51 by 51 mm), with the sides parallel to the wales and courses. The specimen may or may not be cut from the sample unit. No two specimens shall include the same wales and courses.

3. NUMBER OF DETERMINATIONS

3.1 Unless otherwise specified in the procurement document, five specimens shall be tested from each sample unit.

4. APPARATUS

4.1 Counting devices. Pick glass, ruler and pointer, projection equipment, or other suitable form of counting device.

5. PROCEDURE

5.1 Unless otherwise specified in the procurement document, all tests shall be performed on material conditioned as specified in Section 4.

5.2 The cloth shall be placed flat, without tension, on a smooth horizontal surface. The number of wales and courses in the specimen shall then be counted, and the number of each per inch (/cm) calculated.

6. REPORT

6.1 The wales and courses of the sample unit shall be the average of the results obtained from the specimens tested, and shall be reported to the nearest whole wale or course per inch (to the nearest whole wale or course/cm).

6.2 Each individual value used to calculate the average shall also be reported.

STRENGTH AND ELONGATION, BREAKING OF WOVEN CLOTH; GRAB METHOD

1. SCOPE

1.1 This method is intended for determining the breaking strength and elongation of woven, non-woven, and coated cloths.

2. TEST SPECIMEN

2.1 The specimen shall be a rectangle of cloth measuring 4 inches (102 mm) by at least 6 inches (152 mm). The long dimension shall be parallel to the direction being evaluated. No two warp specimens shall contain the same warp yarns and no two filling specimens shall contain the same filling yarns. Specimens shall not be taken nearer to the selvage than one tenth of the width of the cloth.

3. NUMBER OF DETERMINATIONS

3.1 Unless otherwise specified in the procurement document, five specimens from each of the warp and filling directions shall be tested from each sample unit.

4. APPARATUS

4.1 Tensioning clamp. A tensioning clamp weighing six ounces (170 g) (see 7.3 and Figure 5100B) so designed that the weight of the clamp is evenly distributed across the complete width of the specimen.

4.2 The procedure for testing is applicable to both constant-rate-of-traverse (CRT) and constant-rate-of-extension (CRE) testers (see 7.1 and 7.2). These testers shall consist of three main parts:

- a. Straining mechanism
- b. Clamping mechanism
- c. Load and elongation recording mechanism

4.2.1 Straining mechanism. A mechanism by which the specimen is strained by a uniform movement of the pulling clamp.

4.2.2 Clamping mechanism. The tester shall have two clamps with two jaws on each clamp. The design of the two clamps shall be such that one jaw may be an integral part of the rigid frame of the clamp and the other jaw shall be fastened to allow a slight vertical movement.

METHOD 5100

4.2.2.1 The dimensions of the back jaw in each clamp shall be 1 inch (25 mm) parallel to the application of load by 1 inch (25 mm) or more perpendicular to the application of load. The dimensions of the front jaw of each clamp shall be 1 inch by 1 inch (25 by 25 mm). Each jaw face shall have a flat, smooth gripping surface. All edges which might cause a cutting action shall be rounded to a radius of not over 1/64 inch (0.4 mm). In cases where the specimen tends to slip when being tested, the jaws may be faced with rubber or other material to prevent slippage.

4.2.3 Load and elongation recording mechanism. The tester shall have a calibrated recording mechanism to indicate the applied load and elongation.

4.2.4 Capacity. The tester shall be of such capacity that the maximum load required to break the specimen shall not be greater than 85 percent or less than 15 percent of the rated capacity.

4.2.5 Tester efficiency. The error of the tester shall not exceed 2 percent up to and including a 50 pound (222 N) load and 1 percent over a 50 pound (222 N) load at any reading within its load range.

5. PROCEDURE

5.1 Preparation of the test specimen.

5.1.1 Woven cloth. One edge of the long dimension of the specimen shall be raveled until a continuous yarn, the length of the specimen, is obtained. Measure 1-1/2 inches (38 mm) in from this edge and draw a thin line the full length of the specimen. This must be accurately parallel to the lengthwise yarns.

5.1.2 Non-woven and coated cloths. On specimens where raveling is not practical, measure and draw a thin line 1-1/2 inches (38 mm) from the edge of the specimen. This must be, as accurately as possible, parallel to the lengthwise direction of the specimen.

5.2 Unless otherwise specified, the specimens shall be conditioned and tested under Standard Atmospheric Conditions in accordance with section 4 of this Standard.

5.2.1 When the wet breaking strength is required, it shall be specified in the applicable procurement document, and the method of wetting out the specimen shall be specified.

METHOD 5100

5.3 Before use, the tester shall be set at the zero point in accordance with the procedure required for the make and model tester being used, and the autographic recording mechanism shall be checked for proper operation. Insure that the recording pen has sufficient ink to avoid depletion of supply during test.

5.4 The gage length shall be 3 inches (76 mm).

5.5 Unless otherwise specified in the procurement document, the tester shall be operated at a uniform pulling speed of 12 ± 0.5 in/min (305 ± 13 mm/min).

5.6 Each jaw face shall be in line both with respect to its mate in the same clamp and to the corresponding jaw in the other clamp.

5.7 Place the specimen between the opened jaws. Align the vertical outside edge of the front 1 inch by 1 inch (25 by 25 mm) top jaw with the vertical line drawn on the specimen and securely tighten the top clamp. Attach the tensioning clamp specified in 4.1 to the bottom edge of the specimen. Align the vertical outside edge of the 1 inch by 1 inch (25 by 25 mm) bottom jaw with the line drawn on the specimen and securely tighten the bottom clamp (see Figure 5100A). Remove the tensioning clamp and run the test.

5.7.1 If due to the design of the bottom clamp the tensioning clamp cannot be used, appropriate means shall be taken to insure a uniform application of the 6 ounce (170 g) tension to the specimen before tightening the bottom clamp.

5.8 Observe the specimen during the test to determine if the specimen breaks in or at the edge of the jaws (jaw breaks), all yarns in the test area do not break, the specimen slips in the jaws, or the rupture of the specimen follows a random pattern. If any of the above or any other anomaly occurs which is due to faulty testing techniques and the result falls markedly below the average for the sample unit, discard the result and take another specimen. Continue this procedure until the required number of acceptable breaks have been obtained.

5.8.1 It shall be noted that certain cloths because of their inherent characteristics will not yield breaks other than jaw breaks.

5.9 When testing for elongation it shall be obtained simultaneously with the breaking strength. The elongation at the breaking point or other required load shall be expressed as the percent increase in length of the tensioned specimen held between the jaws. Elongation shall be determined

METHOD 5100

from the graph of the autographic recording mechanism in accordance with the procedure required for the make and model tester being utilized.

5.9.1 That initial portion of the load-elongation curve (initial vertical traverse of the pen) which indicates elongation without load (other than the tensioning load) shall not be included in the calculation of elongation.

6. REPORT

6.1 The breaking strength of the sample unit shall be the average of the results obtained from the specimens tested in each of the warp and filling directions and shall be reported separately as follows:

<u>Breaking strength</u>	<u>Reported to nearest</u>
0-500 lbs. (0-2220 N)	1 lb. (1 N)
501 lbs. and up (2221 N and up)	5 lbs. (10 N)

6.2 The elongation of the sample unit shall be the average of the results obtained from the specimens tested in each of the warp and filling directions and shall be reported to the nearest 1.0 percent.

6.3 Each individual value obtained for each specimen tested shall also be reported.

7. NOTES

7.1 Unless otherwise specified in the procurement document, a constant-rate-of-load (CRL) tester will not be used.

7.2 The results obtained on a CRT tester may not be reproducible on a CRE tester and vice versa. Generally, for acceptance testing, it is not recommended to compare the results obtained on a CRT tester to those obtained on a CRE tester. In case of dispute it is recommended that a constant-time-to-break (20 ± 3 sec) be used.

7.3 The tensioning clamp weighing six ounces (170 g) described in this method may be obtained from Custom Scientific Instruments, Inc., 13 Wing Drive, Whippany, NJ 07981.

Example. - Gage length (distance between jaws)

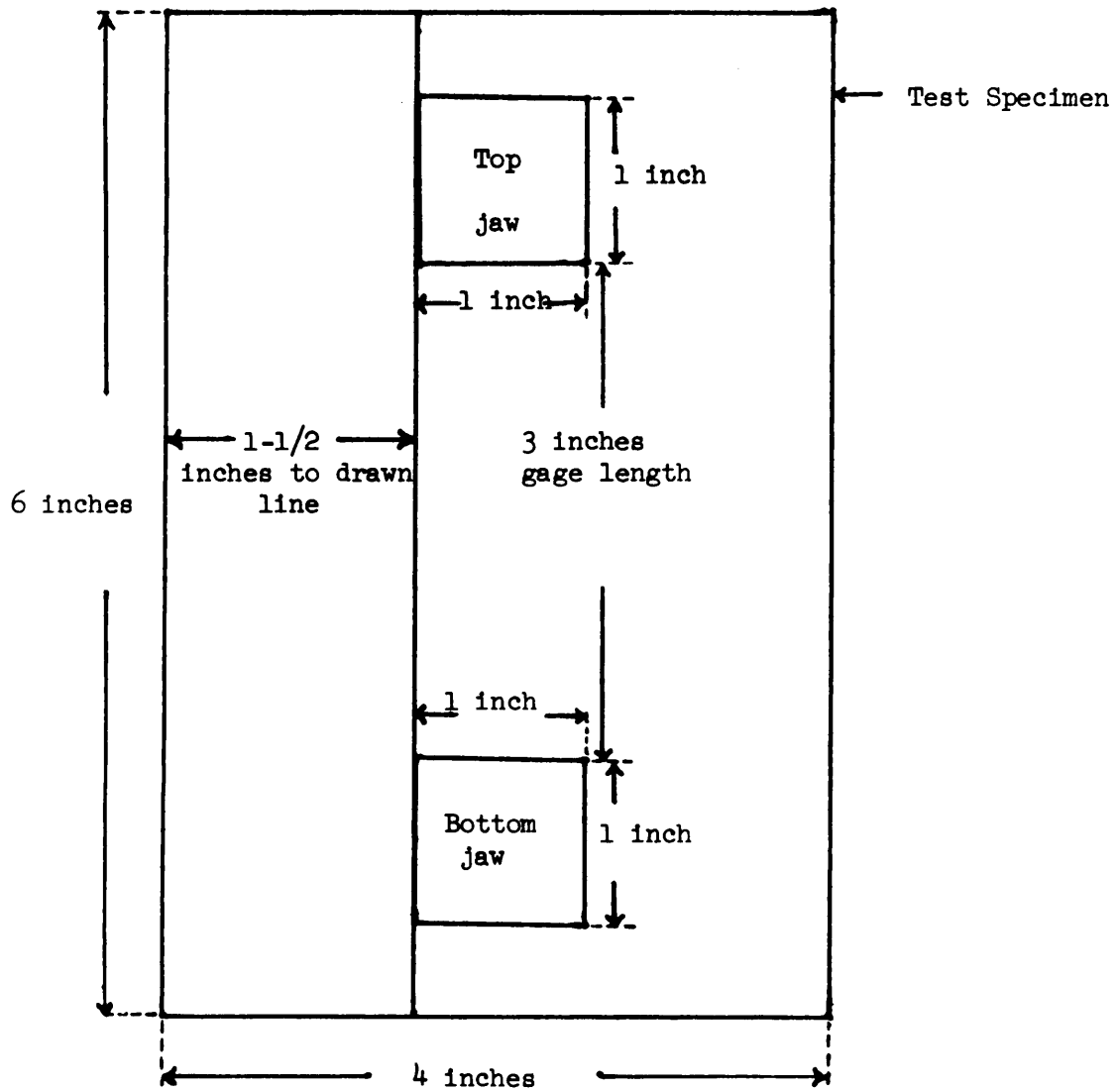

FIGURE 5100A

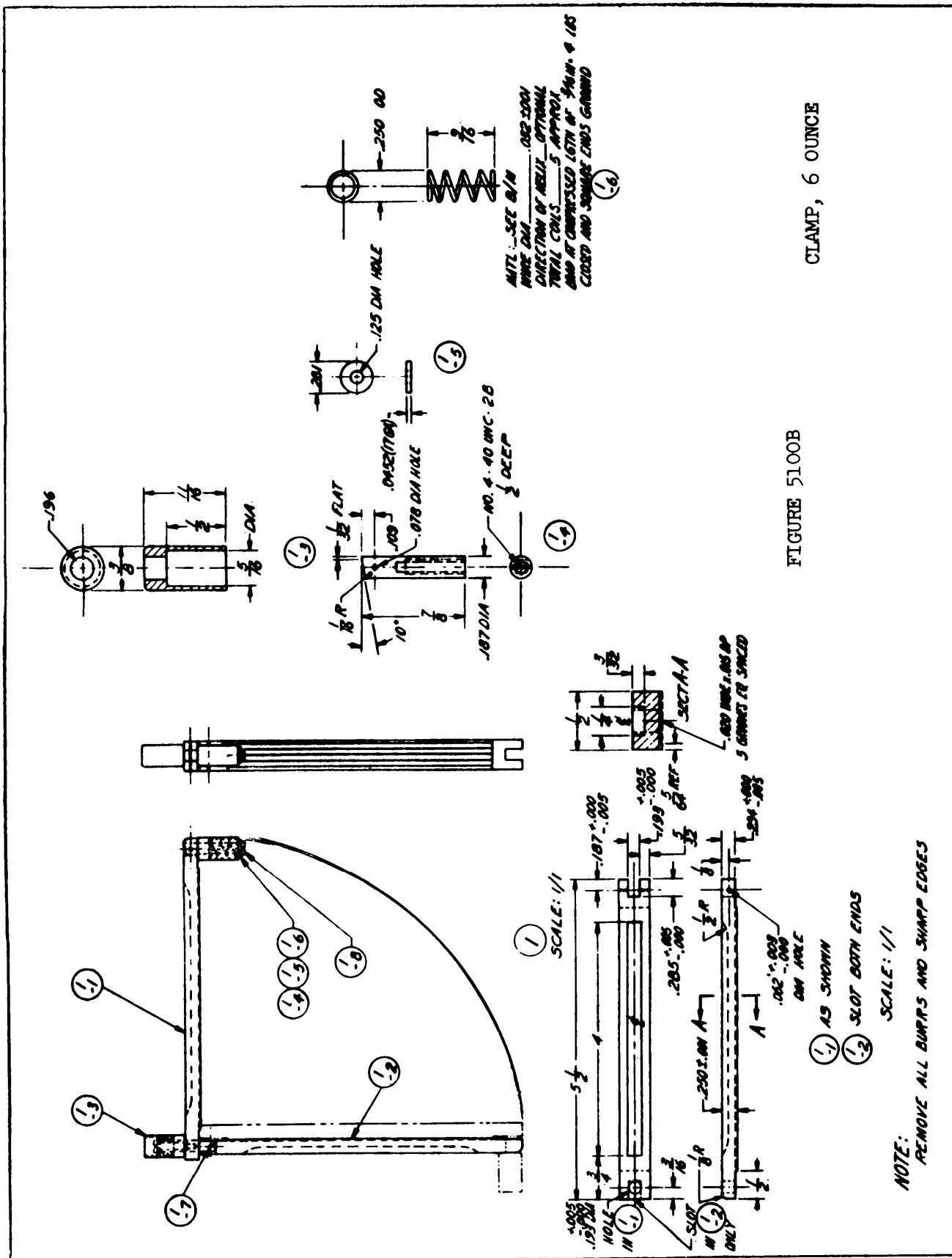

FIGURE 5100B

STRENGTH AND ELONGATION, BREAKING OF WOVEN CLOTH; CUT STRIP METHOD

1. SCOPE

1.1 This method is intended for determining the breaking strength and elongation of heavily sized, coated, and other cloths for which it is impractical to prepare a ravel strip specimen.

2. TEST SPECIMEN

2.1 The specimen shall be a rectangle of cloth measuring 1 inch (25 mm) by at least 6 inches (152 mm). The specimen shall be cut with a die. The long dimension shall be parallel to the direction being evaluated. No two warp specimens shall contain the same warp yarns and no two filling specimens shall contain the same filling yarns. Specimens shall not be taken nearer to the selvage than one tenth of the width of the cloth.

2.2 In critical cases, the procurement document shall state where in the pattern the repeat is to begin.

3. NUMBER OF DETERMINATIONS

3.1 Unless otherwise specified in the procurement document, five specimens from each of the warp and-filling directions shall be tested from each sample unit.

4. APPARATUS

4.1 Tensioning clamp. A tensioning clamp weighing six ounces (170 g) (see 7.3 and Figure 5102) so designed that the weight of the clamp is evenly distributed across the complete width of the specimen.

4.2 The procedure for testing is applicable to both constant-rate-of-traverse (CRT) and constant-rate-of-extension (CRE) testers (see 7.1 and 7.2). These testers shall consist of three main parts:

- a. Straining mechanism.
- b. Clamping mechanism.
- c. Load and elongation recording mechanism.

4.2.1 Straining mechanism. A mechanism by which the specimen is strained by a uniform movement of the pulling clamp.

MBTHOD 5102

4.2.2 Clamping mechanism. The tester shall have two clamps with two jaws on each clamp. The design of the two clamps shall be such that one jaw may be an integral part of the rigid frame of the clamp and the other jaw shall be fastened to allow a slight vertical movement.

4.2.2.1 The dimensions of the front and back jaws in each clamp shall be at least 1 inch by 1-1/2 inches (25 by 38 mm) with the longer dimension perpendicular to the application of load. Each jaw face shall have a flat, smooth gripping surface. All edges which might cause a cutting action shall be rounded to a radius of not over 1/64 inch (0.4 mm). In cases where the specimen tends to slip when being tested, the jaws may be faced with rubber or other material to prevent slippage.

4.2.3 Load and elongation recording mechanism. The tester shall have a calibrated recording mechanism to indicate the applied load and elongation.

4.2.4 Capacity. The tester shall be of such capacity that the maximum load required to break the specimen shall not be greater than 85 percent or less than 15 percent of the rated capacity.

4.2.5 Tester efficiency. The error of the tester shall not exceed 2 percent up to and including a 50 pound (222 N) load and 1 percent over a 50 pound (222 N) load at any reading within its load range.

5. PROCEDURE

5.1 Unless otherwise specified in the procurement document, the specimens shall be conditioned and tested under Standard Atmospheric Conditions in accordance with Section 4 of this Standard.

5.1.1 When the wet breaking strength is required, it shall be specified in the applicable procurement document and the method of wetting out the specimen shall be specified.

5.2 Before use, the tester shall be zeroed in accordance with the procedure required for the make and model tester being used and the autographic recording mechanism shall be checked for proper operation. Insure that the recording pen has sufficient ink to avoid depletion of supply during test.

5.3 The gage length shall be 3 inches (76 mm).

5.4 Unless otherwise specified in the procurement document, the tester shall be operated at a uniform pulling speed of 12 ± 0.5 in/min (305 ± 13 mm/min).

5.5 Each jaw face shall be in line both with respect to its mate in the same clamp and to the corresponding jaw in the other clamp.

METHOD 5102

5.6 Place the specimen between the opened jaws. Center the specimen between the top jaws and securely tighten the top jaws so that the specimen is parallel to the application of load. Attach the tensioning clamp to the bottom edge of the specimen. Center and align the specimen in the bottom jaws and securely tighten these jaws. Remove the tensioning clamp and run the test.

5.6.1 If due to the design of the bottom clamp the tensioning clamp cannot be used, appropriate means shall be taken to insure a uniform application of the 6 ounce (170 g) tension before tightening the bottom clamp.

5.7 Observe the specimen during the test to determine if the specimen breaks in or at the edge of the jaws (jaw breaks), all yarns in the test area do not break, the specimen slips in the jaws, or the rupture of the specimen follows a random pattern. If any of the above or any other anomaly occurs, which is due to faulty testing technique, and the result falls markedly below the average for the sample unit, discard the result and take another specimen. Continue this procedure until the required number of acceptable breaks have been obtained.

5.7.1 It is to be noted that certain cloths because of their inherent characteristics will not yield breaks other than jaw breaks.

5.8 When testing for elongation it shall be obtained simultaneously with the breaking strength. The elongation at the breaking point or other required load shall be expressed as the percent increase in length of the tensioned specimen held between the jaws. Elongation shall be determined from the graph of the autographic recording mechanism in accordance with the procedure required for the make and model tester being utilized.

5.8.1 That initial portion of the load-elongation curve (initial vertical traverse of the pen) which indicates elongation without load (other than the tensioning load) shall not be included in the calculation of elongation.

60 REPORT

6.1 The breaking strength of the sample unit shall be the average of the results obtained from the specimens tested in each of the warp and filling directions and shall be reported separately as follows:

<u>Breaking strength</u>	<u>Reported to nearest</u>
0-500 lbs (0-2220 N)	1 lb (1 N)
501 lbs and up (2221 N and up)	5 lbs (10 N)

METHOD 5102

6.2 The elongation of the sample unit shall be the average of the results obtained from the specimens tested in each of the warp and filling directions and shall be reported to the nearest 1.0 percent.

6.3 Each individual value obtained for each specimen tested shall also be reported.

7. NOTES

7.1 Unless otherwise specified in the procurement document, a constant-rate-of-load (CRL) tester will not be used.

7.2 The results obtained on a CRT tester may not be reproducible on a CRE tester and vice versa. Generally, for acceptance testing, it is not recommended to compare the results obtained on a CRT tester to those obtained on a CRE tester. In case of dispute it is recommended that a constant-time-to-break (20 ± 3 sec) be used.

7.3 The tensioning clamp weighing six ounces (170 g) described in this method may be obtained from Custom Scientific Instruments, Inc., 13 Wing Drive, Whippany, NJ 07981.

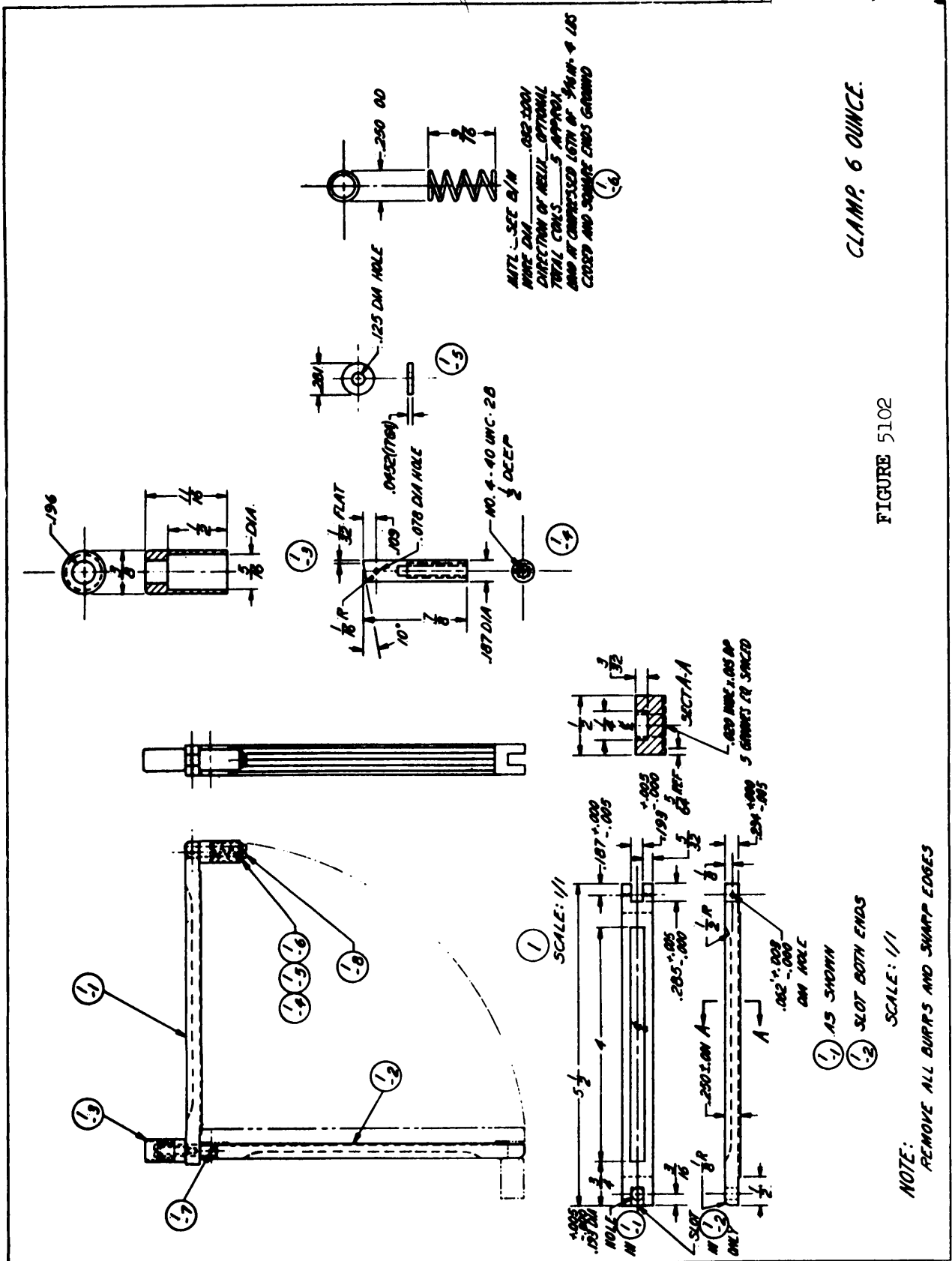

CLAMP, 6 OUNCE.

FIGURE 5102

STRENGTH AND ELONGATION, BREAKING OF WOVEN CLOTH; RAVEL STRIP METHOD

1. SCOPE

1.1 This method is intended for determining the breaking strength and elongation of a specific width of woven cloth. It is not recommended for cloths having less than twenty yarns across the width of the specimen.

1.2 The breaking strength as determined by this method is particularly useful for comparing the effective strength of yarns in a woven cloth with their strength before weaving.

2. TEST SPECIMEN

2.1 The specimen shall be a rectangle of cloth measuring 1-1/2 inches (38 mm), by at least 6 inches (152 mm). The long dimension shall be parallel to the direction being evaluated. No two warp specimens shall contain the same warp yarns and no two filling specimens shall contain the same filling yarns. Specimens shall not be taken nearer to the selvege than one tenth of the width of the cloth.

2.1.1 When a specimen containing a specific number of yarns is specified, the specimen shall be cut 1/2 inch (13 mm), or twenty yarns, wider than the number of yarns specified.

2.1.2 The specimen shall be raveled to a 1 inch (25 mm) width or other specified number of yarns by removing an approximately equal number of yarns from each side of the specimen.

2.2 When this test is specified for cloths having less than twenty yarns per inch (yarns/cm), the specimen shall be cut 2-1/2 inches (64 mm) wide, or 2 inches (51 mm) plus twenty yarns, whichever is wider, by at least 6 inches (152 mm).

2.2.1 The specimen shall be raveled to a 2-inch (51 mm) width by removing ten or an approximately equal number of yarns from each side of the specimen.

2.3 In critical cases, the procurement document shall state where in the pattern the repeat is to begin.

3. NUMBER OF DETERMINATIONS

3.1 Unless otherwise specified in the procurement document, five specimens from each of the warp and filling directions shall be tested from each sample unit.

METHOD 5104

4. APPARATUS

4.1 Tensioning clamp. A tensioning clamp weighing six ounces (170 g) (see 7.3 and Figure 5104) so designed that the weight is evenly distributed across the complete width of the specimen.

4.2 The procedure for testing is applicable to both constant-rate-of-traverse (CRT) and constant-rate-of-extension (CRE) testers (see 7.1 and 7.2). These testers shall consist of three main parts:

- a. Straining mechanism.
- b. Clamping mechanism.
- c. Load and elongation recording mechanism.

4.2.1 Straining mechanism. A mechanism by which the specimen is strained by a uniform movement of the pulling clamp.

4.2.2 Clamping mechanism. The tester shall have two clamps with two jaws on each clamp. The design of the two clamps shall be such that one jaw may be an integral part of the rigid frame of the clamp and the other jaw shall be fastened to allow a slight vertical movement.

4.2.2.1 The dimensions of the front and back jaws in each clamp shall be at least 1/2 inch (13 mm) wider than the specimen being tested. The jaws shall be at least 1 inch (25 mm) parallel to the application of load. Each jaw face shall have a flat, smooth gripping surface. All edges which might cause a cutting action shall be rounded to a radius of not over 1/16 inch (0.4 mm). In cases where the specimen tends to slip when being tested, the jaws may be faced with rubber or other material to prevent slippage.

4.2.3 Load and elongation recording mechanism. The tester shall have a calibrated recording mechanism to indicate the applied load and elongation.

4.2.4 Capacity. The tester shall be of such capacity that the maximum load required to break the specimen shall not be greater than 85 percent or less than 15 percent of the rated capacity.

4.2.5 Tester efficiency. The error of the tester shall not exceed 2 percent up to and including a 50 pound (222 N) load and 1 percent over a 50 pound (222 N) load at any reading within its load range.

5. PROCEDURE

5.1 Unless otherwise specified in the procurement document, the specimens shall be conditioned and tested under Standard Atmospheric Conditions in accordance with Section 4 of this Standard.

FED-STD-191A

FED. TEST METHOD STD. NO. 191A

METHOD 5104

5.1.1 When the wet breaking strength is required, it shall be specified in the applicable procurement document and the method of wetting out the specimen shall be specified.

5.2 Before use, the tester shall be zeroed in accordance with the procedure required for the make and model tester being utilized and the autographic recording mechanism shall be checked for proper operation. Insure that the recording pen has sufficient ink to avoid depletion of supply during test.

5.3 The gage length shall be 3 inches (76 mm).

5.4 Unless otherwise specified in the procurement document, the tester shall be operated at a uniform pulling speed of 12 ± 0.5 in/min (305 ± 13 mm/min).

5.5 Each jaw face shall be in line both with respect to its mate in the same clamp and to the corresponding jaw in the other clamp.

5.6 Place the specimen between the opened jaws. Center the specimen between the top jaws and securely tighten the top jaws so that the specimen is parallel to the application of load. Attach the tensioning clamp to the bottom edge of the specimen. Center and align the specimen in the bottom jaws and securely tighten these jaws. Remove the tensioning clamp and run the test.

5.6.1 If due to the design of the bottom clamp the tensioning clamp cannot be used, appropriate means shall be taken to insure a uniform application of the 6 ounce (170 g) tension before tightening the bottom clamp.

5.7 Observe the specimen during the test to determine if the specimen breaks in or at the edge of the jaws (jaw breaks), all yarns in the test area do not break, the specimen slips in the jaws, or the rupture of the specimen follows a random pattern. If any of the above or any other anomaly occurs, which is due to faulty testing technique, and the result falls markedly below the average for the sample unit, discard the result and take another specimen. Continue this procedure until the required number of acceptable breaks have been obtained.

5.7.1 It is to be noted that certain cloths because of their inherent characteristics will not yield breaks other than jaw breaks.

5.8 When testing for elongation it shall be obtained simultaneously with the breaking strength. The elongation at the breaking point or other required load shall be expressed as the percent increase in length of the tensioned specimen held between the jaws. Elongation shall be determined from the graph of the autographic recording mechanism in accordance with the procedure required for the make and model tester being utilized.

METHOD 5104

5.8.1 That initial portion of the load-elongation curve (initial vertical traverse of the pen) which indicates elongation without load (other than the tensioning load) shall not be included in the calculation of elongation.

6. REPORT

6.1 The breaking strength of the sample unit shall be the average of the results obtained from the specimens tested in each of the warp and filling directions and shall be reported separately as follows:

<u>Breaking strength</u>	<u>Reported to nearest</u>
0-500 lbs (0-2220 N)	1 lb (1 N)
501 lbs and up (2221 N and up)	5 lbs (10 N)

6.2 The elongation of the sample unit shall be the average of the results obtained from the specimens tested in each of the warp and filling directions and shall be reported to the nearest 1.0 percent.

6.3 Each individual value obtained for each specimen tested shall also be reported.

7. NOTES

7.1 Unless otherwise specified in the procurement document, a constant-rate-of-load (CRL) tester will not be used.

7.2 The results obtained on a CRT tester may not be reproducible on a CRE tester and vice versa. Generally, for acceptance testing, it is not recommended to compare the results obtained on a CRT tester to those obtained on a CRE tester. In case of dispute it is recommended that a constant-time-to-break (20 ± 3 sec) be used.

7.3 The tensioning clamp weighing six ounces (170 g) described in this method may be obtained from Custom Scientific Instruments, Inc., 13 Wing Drive, Whippany, NJ 07981.

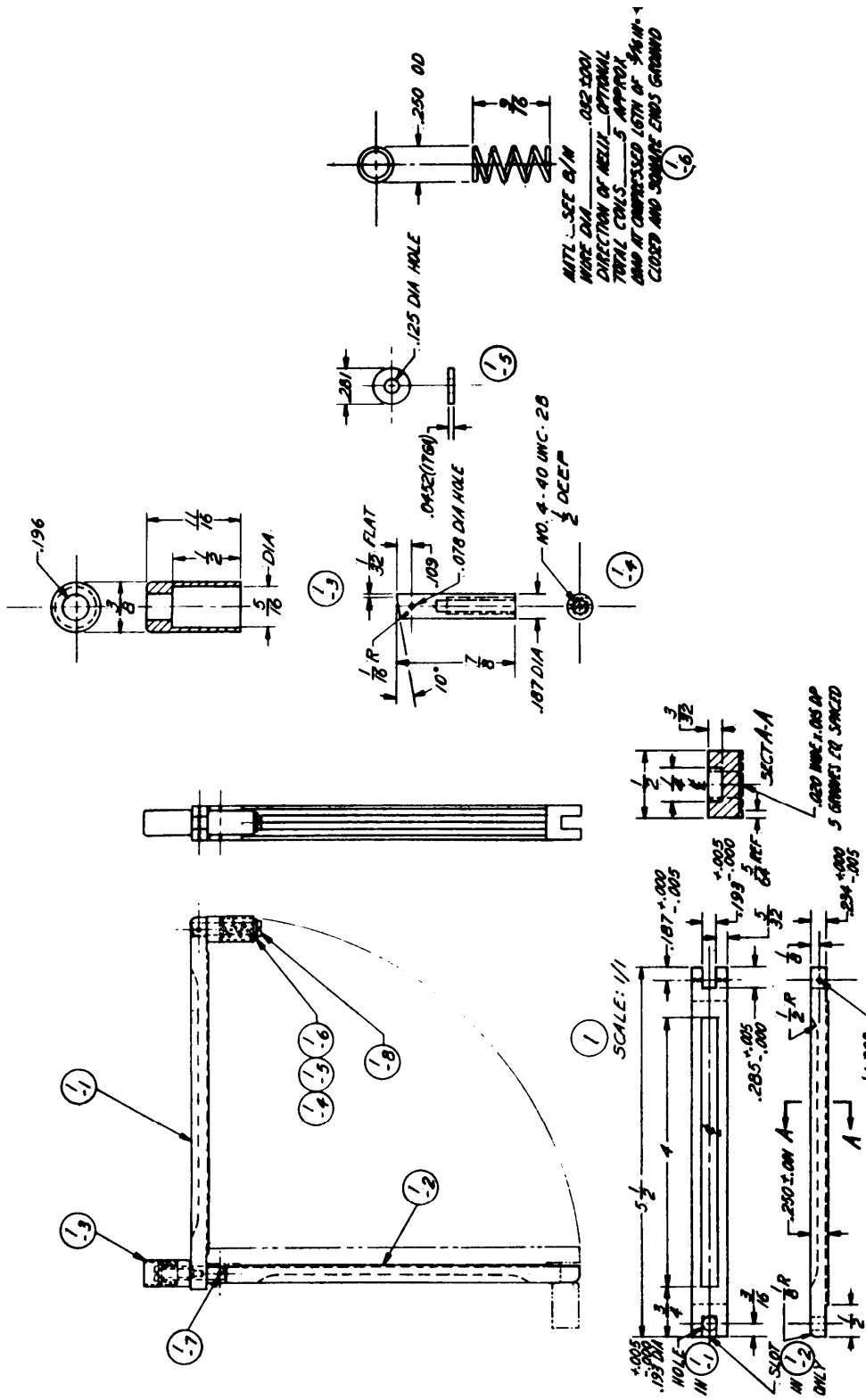

CLAMP, 6 OUNCE.

FIGURE 5104

NOTE:
REMOVE ALL BURRS AND SHARP EDGES

TENSION OF ELASTIC TEXTILE MATERIALS

1. SCOPE

1.1 This method is intended for determining the amount of load to produce specified elongation (tension) in woven or knitted elastic or stretch cloths, tapes, and webbings when subjected to specified loads on a constant-rate-of-load tensile testing machine.

2. TEST SPECIMEN

2.1 Materials 3 inches (76 mm) or less in width. Unless otherwise specified in the procurement document, the test specimen shall be a full width piece of the material 14 inches (356 mm) in length. The specimen shall be prepared as specified in 5.1.

2.2 Materials over 3 inches (76 mm) in width. Unless otherwise specified in the procurement document, the long dimension of the specimen shall be parallel to the lengthwise direction of the material.

2.2.1 Material that will ravel. The specimen shall be 14 inches (356 mm) in length, and yarns shall be removed from each side, along the length of the specimen, to obtain a width of approximately 3 inches (76 mm). The specimen shall then be prepared as specified in 5.1.

2.2.2 Material that will not ravel. The specimen shall be 14 inches (356 mm) in length and cut 3.00 ± 0.05 inches (76 mm \pm 1 mm) wide. The specimen shall then be prepared as specified in 5.1.

3. NUMBER OF DETERMINATIONS

3.1 Unless otherwise specified in the procurement document, five specimens shall be tested from each sample unit.

4. APPARATUS

4.1 Tensile testing machine. A tensile testing machine, constant-rate-of-load type equipped with suitable pins or rods for holding a looped specimen. The total distance encompassing the pins (see Figure 5106) shall be 10.00 ± 0.06 inches (254 mm \pm 1 mm) at the start of the test. The machine shall have a full loading and unloading cycle of 40 ± 2 seconds (see 7.1).

4.1.2 Recording mechanism. Autographic mechanism.

METHOD 5106

5. PROCEDURE

5.1 Preparation of specimen.

5.1.1 Unless otherwise specified in the procurement document, all tests on specimens shall be performed under standard conditions in accordance with Section 4 of this standard. All test specimens shall be allowed to relax free from tension for a minimum of 16 hours.

5.1.2 All wrinkles shall be removed from the specimen by hand. When the specimen is laying flat without tension, bench marks shall be placed 10.00 ± 0.06 inches (254 mm \pm 1 mm) apart on the specimen. The specimen shall then be sewn together on the coincided bench marks to form a loop with an inside periphery of 10.00 ± 0.06 inches (254 mm \pm 1 mm).

5.1.2.1 The thread and stitch type for sewing the specimen to form the loop shall be such that the seam will not break during the test.

5.2 Before the beginning of any testing, the machine shall be zeroed in accordance with the procedure required for the make and model of the machine being used.

5.2.1 Prior to mounting the test specimen, the calibrated graph paper shall be placed in the holder of the autographic recording mechanism, and the machine shall be run to insure that the mechanism is operating properly (care should be taken to insure that the ink supply is sufficient to avoid depletion during the testing).

5.3 The loop specimen shall be dropped around the pins of the tester so that a figure "0" is formed, with a pin at each end of the "0". The seam shall be centered between the pins or rods (see Figure 5106). The load as specified in the procurement document shall be applied to the specimen for the full cycle of the plane of the testing machine. The full cycle shall be repeated for a total of 5 cycles. The loading curve of the fifth cycle shall be used to determine the tension of the specimen.

5.4 Calculation of results. The tension in pounds of the specimen shall be the load on the specimen, at the specified elongation, divided by 2. The load at the specified elongation shall be determined on the loading curve recorded by the autographic recording mechanism of the test apparatus.

6. REPORT

6.1 The tension of the sample unit shall be reported as the average of the results obtained from the specimens tested, and shall be reported to the nearest 0.1 pound (to the nearest 0.1 N) for materials 3 inches (76 mm) or less in width, and to the nearest 0.1 pound (to the nearest 0.1 N) per 3 inches (76 mm) of width for materials over 3 inches (76 mm) in width.

METHOD 5106

6.2 Each individual value used to calculate the average shall also be reported.

7. NOTE

7.1 A machine of the type described in this method is Scott IP4 Tester and may be purchased from Scott Testers Inc., Division of Bendix Corporation, 101 Blackstone St., Providence, RI 02901.

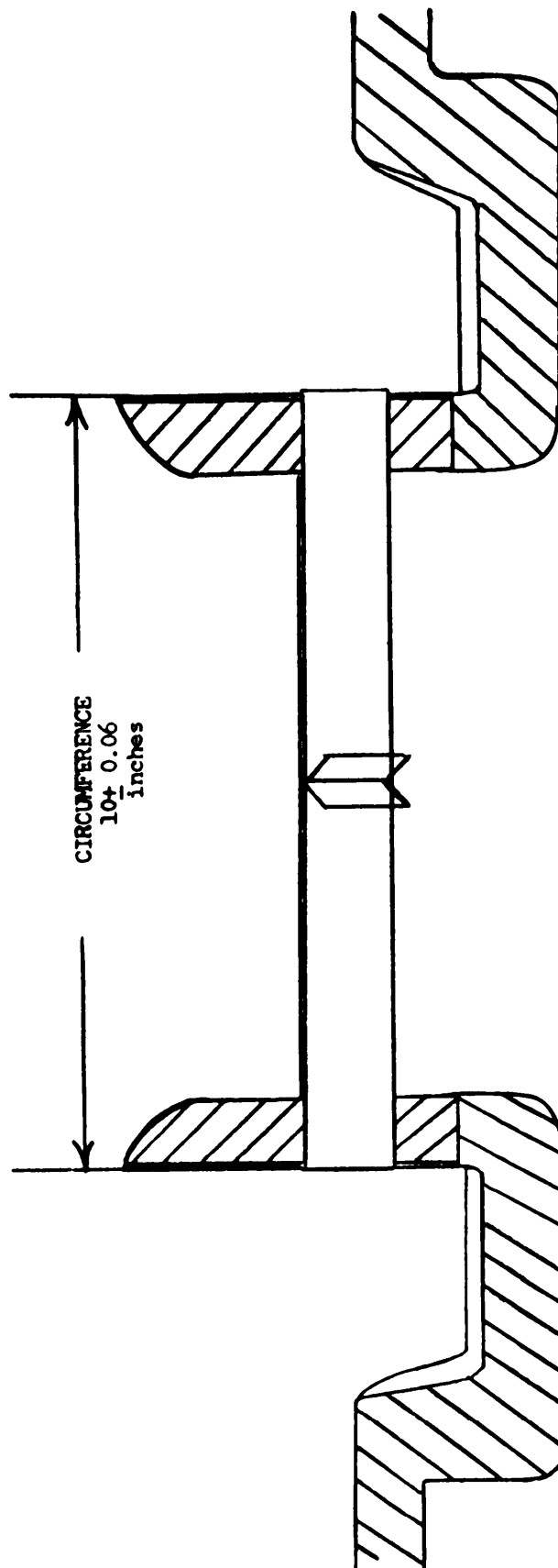

FIGURE 5106 - Diagram Showing Loop Specimen in Place on Pins

SEWABILITY OF WOVEN CLOTH; SEAM EFFICIENCY METHOD

1. SCOPE

1.1 This method is intended to determine the sewability of woven cloth. The result represents the ratio of strength retained along the line of stitching, and is based on the relationship between the breaking strength of the cloth at the seam and the breaking strength of the cloth with no stitching.

2. TEST SPECIMEN

2.1 The test specimens shall be prepared from a piece of cloth 20 inches (508 mm) wide and 48 inches (1219 mm) long with the long dimension parallel to the warp direction as specified in 5.1.

3. NUMBER OF DETERMINATIONS

3.1 Unless otherwise specified in the procurement document, seven specimens shall be tested from each sample unit.

4. APPARATUS, METHOD CITED AND STANDARD CITED

4.1 Apparatus.

4.1.1 Sewing machine. A double-tandem needle, 1/4 inch (6 mm) gauge sewing machine, making stitch type 401 of FED-STD-751 and operating at 4300 ± 100 stitches (revolutions) per minute shall be used. The machine shall be fitted with a folder capable of properly forming seam type LSc-2 of FED-STD-751.

4.1.2 Needles and thread. Unless otherwise specified in the procurement document, chrome-plated, regular set, round cloth point needles shall be used. Needles with ball points or cutting points shall not be used. Ball eye needles may be used provided the measurement across the eye meets the requirement specified in the end item procurement document. The thread type and size and the needle size shall be as specified in the procurement document.

4.1.3 Since the test is designed to evaluate the damage of cloth yarns and the resultant effect on the cloth strength at the seam, the kind, type of thread, and the size, along with the number of stitches per inch (stitches/cm), should be selected to insure that the stitching does not fail in the testing.

4.1.4 Tensile tester. A tensile tester of the type described in Method 5100.

METHOD 5110

4.2 Method cited.

Method 5100, Strength and Elongation, Breaking of Woven Cloth; Grab Method

4.3 Standard cited.

FED-STD-751 - Stitches, Seams, and Stitchings

5* PROCEDURE

5.1 Preparation of specimen. The specimen shall be prepared as follows:

5.1.1 The test specimen shall be cut parallel to the warp direction into 2 strips, one 12 inches by 48 inches (305 mm by 1219 mm), and the other 8 inches by 48 inches (203 mm by 1219 mm), as shown on figure 5110A. The strips shall then be seamed together with the cloth face up along their lengths with seam type LSc-2 and stitch type 401 of FED-STD-751, 1/4-inch (6 mm) gauge or distance between the rows of stitches. The seam shall then be sewn straight and carefully to insure the 2 pieces retain as closely as possible the same relationship filling-wise in the seam as in the uncut 20 by 48 inch (508 mm by 1219 mm) piece.

5.1.2 Twelve \pm 1 stitches per inch ($5 \pm 1/2$ stitches/cm) shall be used on the seam. The tension on the sewing thread shall be adjusted to properly form stitch type 401 of FED-STD-751 without puckering. The distribution of the thread in the stitch by length shall be 40 ± 5 percent needle thread and 60 ± 5 percent looper thread.

5.1.3 The seam shall be inspected for proper folding and stitching. Tests shall not be made of any specimen improperly formed, or with more or less than the specified number of stitches per inch (stitches/cm) or with improper length of sewing thread in needle or bobbin.

5.1.4 The individual specimens shall be marked on the seamed strip (5.1.1) with lines 4 inches (102 mm) apart and parallel to the filling yarns (perpendicular to the seam) extending across the full width of the seamed strip (see figure 5110A). The first line shall be 6 inches (152 mm) from the end of the strip where sewing of the seam was started. As an aid in aligning the specimen symmetrically in the clamps of the testing machine, a line shall be marked parallel to the filling direction of the cloth a distance of 1.5 inches (38 mm) from 1 edge of the individual specimens.

5.2 Unless otherwise specified in the procurement document, all tests shall be performed on material conditioned as specified in Section 4.

5.3 The 7 specimens for the breaking strength tests shall be cut from the seamed strip along the marks spaced 4 inches (102 mm) apart (see figure 5110B). Three extra specimens are provided in the event of bad breaks, skipped stitches, etc.

METHOD 5110

5.4 Testing. Two determinations of the breaking strength of the same 1-inch (25 mm) center section of filling yarns in each specimen shall be made. The first, cloth strength, is the breaking strength of the filling yarns in the unseamed portion of the 12-inch (305 mm) strip. The second, seam strength, is the breaking strength of the same 1-inch (25 mm) center section of filling yarns in the 12-inch (305 mm) strip and the corresponding filling yarns in the 8-inch (203 mm) strip.

5.4.1 Cloth strength. The 12-inch (305 mm) strip of the specimen shall be placed in the clamps of the testing machine with the filling yarns parallel to the direction of application of load. The specimen shall be aligned symmetrically in the clamps of the testing machine with the 1-inch (25 mm) center section securely fastened in the jaws and 1.5 inches (38 mm) of cloth width extending beyond each side of the clamps of the machine. The drawn line shall be placed adjacent to the nearest edge of the upper and lower jaw to insure gripping the same yarns in the clamps. Insure that the cloth is clamped a sufficient distance from the seam so that its rupture will not influence the determination of seam strength. The specimen shall be tested and breaking strength recorded.

5.4.2 Seam strength. The clamps of the machine shall be loosened. The specimen shall be repositioned in the clamps by roving it parallel to the direction of application of the load, following the same filling yarns broken in 5.4.1, until the seam is midway between the 2 clamps and perpendicular to the direction of application of the force. The specimen shall then be realigned in the clamps as specified in 5.4.1, so that the same filling yarns as those in 5.4.1 will be broken. Care shall be taken to exclude that portion of the cloth ruptured in obtaining the cloth strength. The specimen shall be tested and the breaking strength of the seam recorded.

5.5 If a specimen slips between the jaws, or if, for any reason attributable to faulty technique, an individual measurement falls markedly below the average for the sample unit, such result shall be discarded and another specimen shall be tested.

5.6 Calculation of results. The seam efficiency of the cloth shall be calculated as follows:

$$\text{Seam efficiency, percent} = \frac{\text{Cloth breaking strength at stitching} \times 100}{\text{Original cloth breaking strength}}$$

6. REPORT

6.1 The seam efficiency of the sample unit shall be the average of the results obtained from the specimens tested and shall be reported to the nearest 0.1 percent.

6.2 Each individual value used to calculate the average shall also be reported.

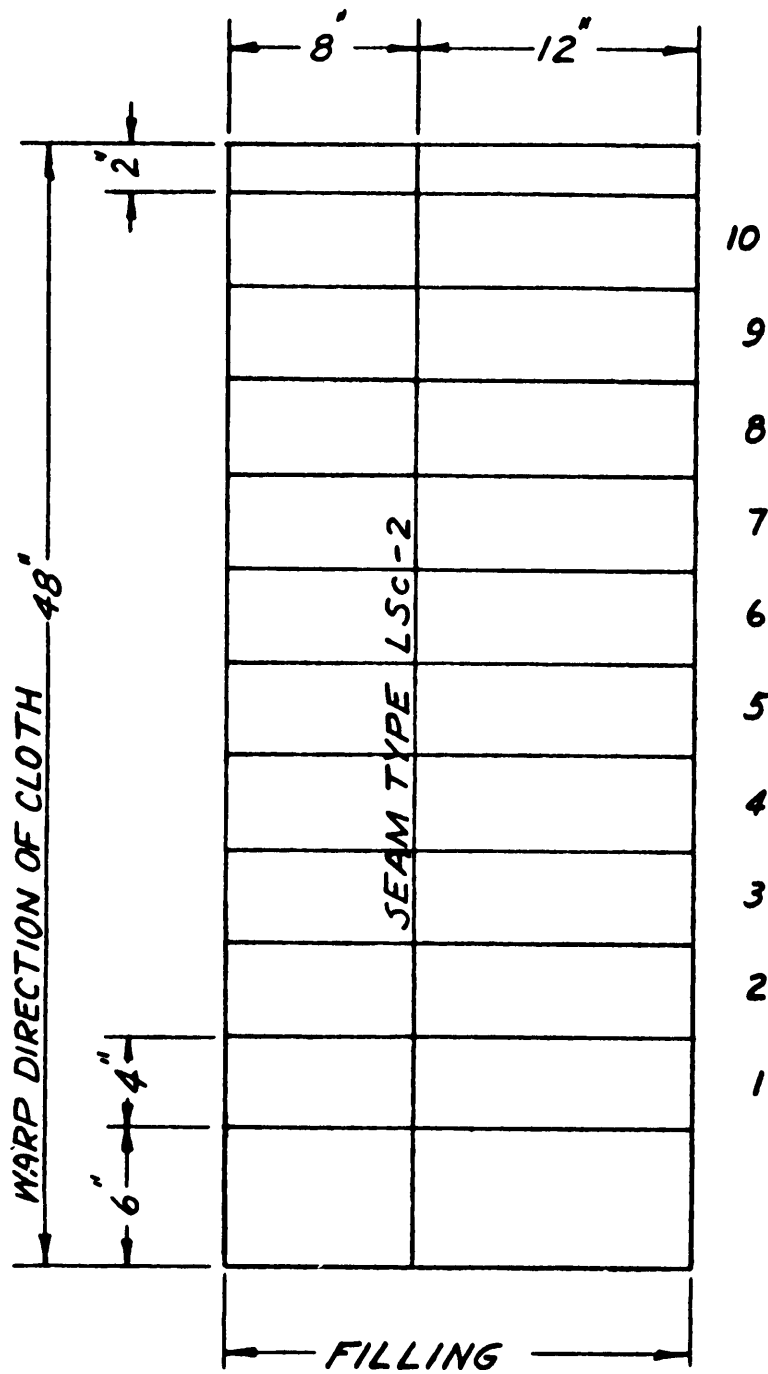

FIGURE 5110A
DIAGRAM FOR PREPARATION OF TEST SPECIMENS

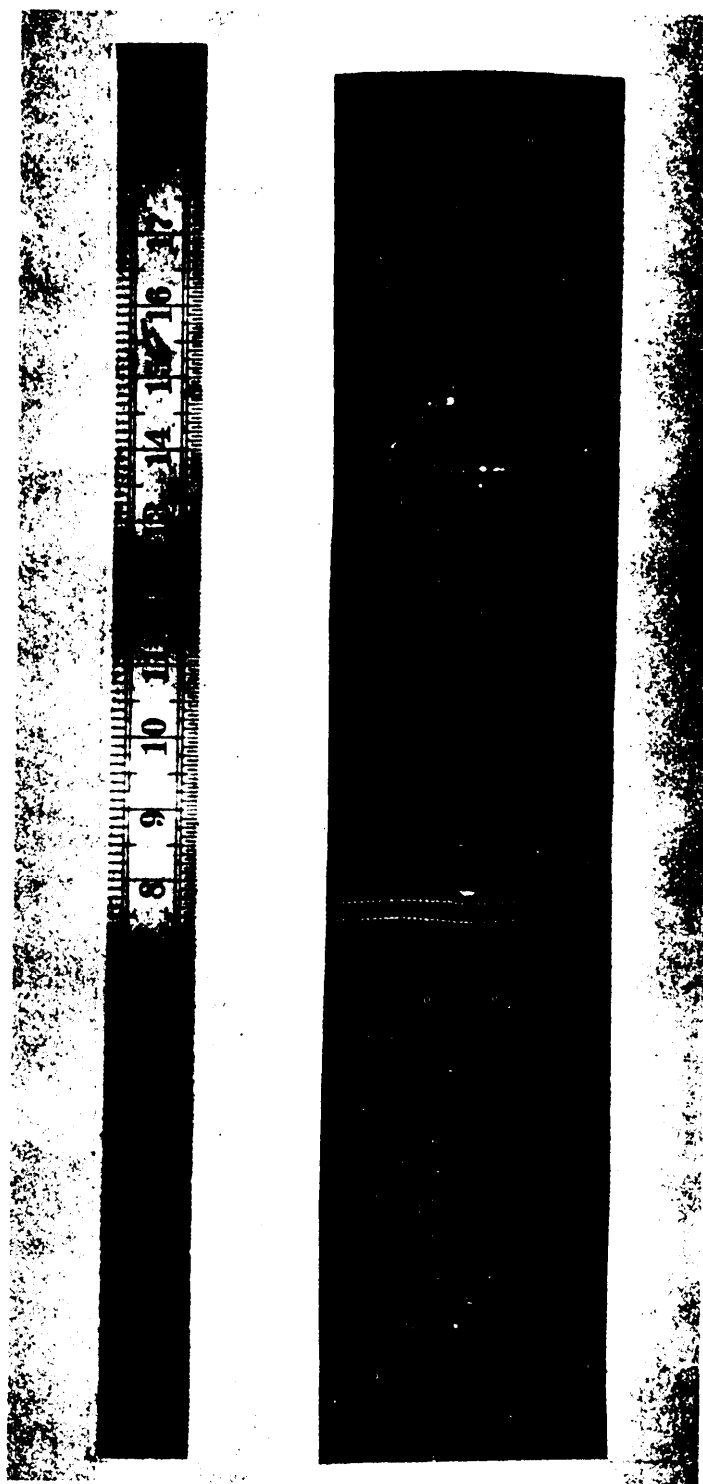

FIGURE 5110B
Typical test specimen

STRENGTH OF CLOTH; BALL BURSTING METHOD

1. SCOPE

1.1 This method is intended for determining the bursting strength of cloths which exhibit a high degree of ultimate elongation. It is not recommended for use on woven cloths.

2. TEST SPECIMEN

2.1 The specimen shall be a piece of cloth of sufficient size to extend beyond the outside diameter of the ring clamp mechanism of the testing machine. No two specimens shall be taken from areas containing the same wales or courses in knitted cloth or the same warp or filling yarns in woven cloth. No selvage shall be included in the sample tested.

3. NUMBER OF DETERMINATIONS

3.1 Unless otherwise specified in the procurement document, five specimens shall be tested from each sample unit.

4. APPARATUS AND METHOD CITED

4.1 Apparatus.

4.1.1 Testing machine as described in Method 5100, except that a ball burst apparatus as shown in figure 5120 shall replace the clamp assembly.

4.1.2 The ball burst apparatus shall consist of a ring clamp mechanism of internal diameter of 1.750 ± 0.001 inch (44.4 ± 0.025 mm). The ring clamp mechanism shall replace 1 clamp of the testing machine. The other clamp shall be replaced by an attachment that shall hold a polished steel ball. This ball shall have a diameter of 1.0000 ± 0.0002 inch (25.4 ± 0.005 mm), shall be spherical to within 0.0002 inch (0.005 mm), and shall be finished to 4 micro-inches or less when visually compared to General Electric roughness standards. This ball shall be periodically cleaned with a suitable solvent to remove any accumulated film of oil or foreign particles. During the test, the relative motion of the steel ball shall be perpendicular to the plane of the ring clamp and through the center of the ring.

4.2 Method cited.

Method 5100, Strength and Elongation, Breaking, of Woven Cloth;
Grab Method.

METHOD 5120

5. PROCEDURE

5.1 Unless otherwise specified in the procurement document, all tests shall be performed on material conditioned as specified in Section 4.

5.2 The specimen shall be placed without tension in the ring clamp and fastened securely by means of a screw or lever device. The machine shall be started and the maximum resistance of the cloth to the passage of the ball shall be recorded. The speed of the pulling clamp shall be 12 ± 0.5 inches (305 ± 13 mm) per minute.

6. REPORT

6.1 The ball-bursting strength of the sample unit shall be the average of the results obtained from the specimens tested, and shall be reported to the nearest 1 pound (to the nearest 1 N).

6.2 Each individual value used to calculate the average shall also be reported.

NOTES: A ball-bursting apparatus of the type described in this method may be obtained from the Scott Tester Co., Inc., Providence, RI and the Thwing-Albert Instrument Co., 10960 Dutton Road, Philadelphia, PA, 19154.

General Electric roughness standards may be obtained from the General Electric Company, local branch office, Catalogue No. 8651831G1.

Suitable solvents for use in cleaning the ball are carbon tetrachloride, trichloroethylene, or perchloroethylene.

BALL BURST ATTACHMENT

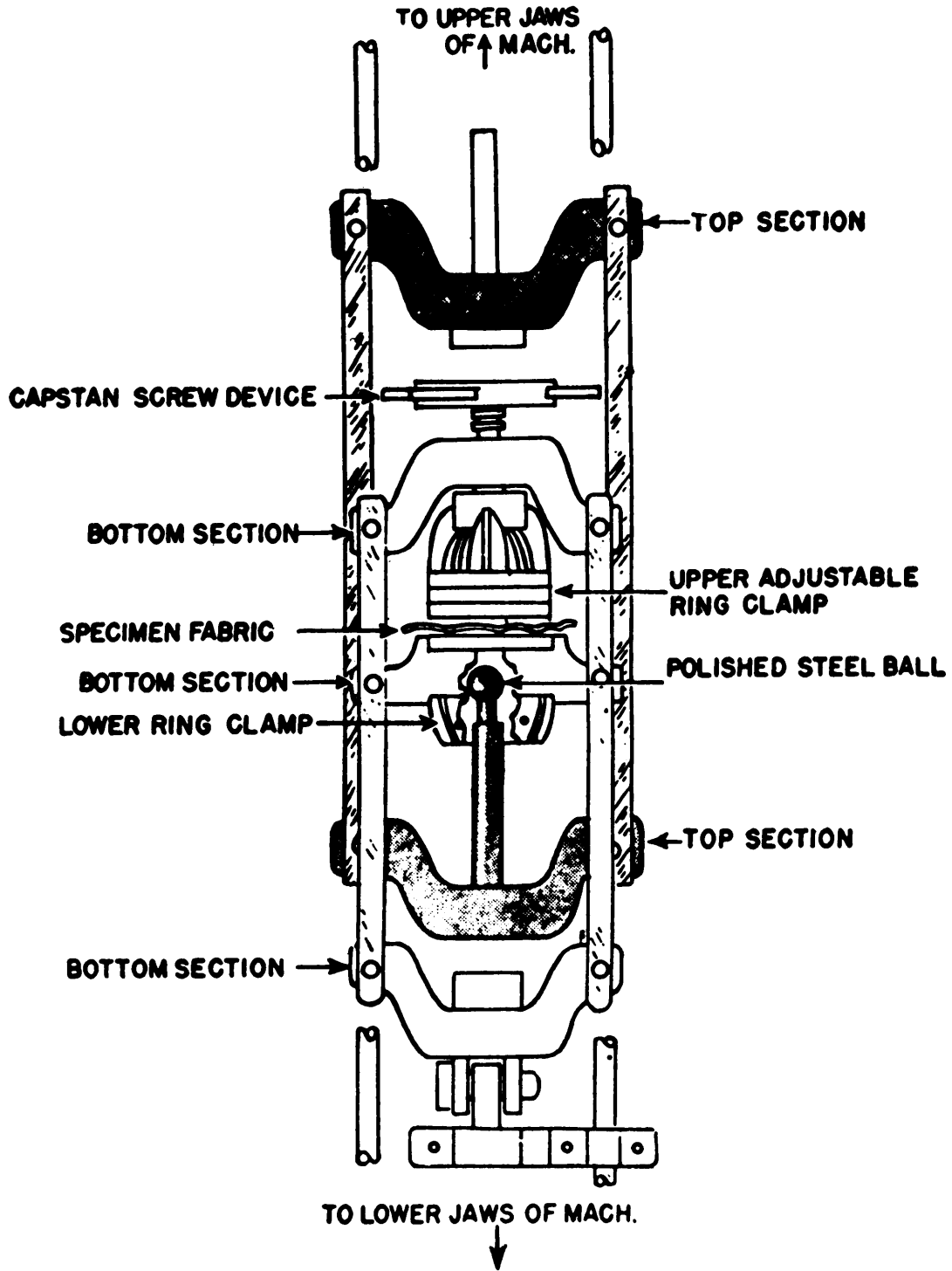

FIGURE 5120

STRENGTH OF CLOTH; DIAPHRAGM BURSTING METHOD

1. SCOPE

1.1 This method is intended for determining the bursting strength of cloth. It is not recommended for general use on uncoated woven cloths.

2. TEST SPECIMEN

2.1 The specimen shall be a circular or square piece of cloth at least 1/2 inch (13 mm) greater than the outside diameter of the ring-clamp mechanism of the testing machine. No two specimens shall be taken from areas containing the same wales or courses in knitted cloths, or the same warp or filling yarns in woven cloths. No selvage shall be included in the sample tested.

3. NUMBER OF DETERMINATIONS

3.1 Unless otherwise specified in the procurement document, five specimens shall be tested from each sample unit.

4. APPARATUS

4.1 The standard testing machine shall be a hand or motor-driven tester, except in cases of dispute wherein a motor-driven tester shall be used.

4.1.1 The testing machine shall permit the cloth to be clamped between two circular clamps not less than 3 inches (76 mm) in diameter and having coaxial apertures of 1.22 ± 0.03 inches (31 ± 0.76 mm) in diameter.

4.1.2 The surfaces of the clamps between which the specimen is placed shall have concentric grooves. The grooves shall be spaced not less than 1/32 inch (0.80 mm) apart and shall be of a depth not less than 0.006 inch (0.15 mm). The grooves shall not start closer than 0.125 inch (3 mm) from the edge of the aperture. The surfaces of the clamps shall be metallic and any edge which might cause a cutting action shall be rounded to a radius of not more than 1/64 inch (0.4 mm). The lower clamp shall be integral with the chamber in which a screw shall operate to force a liquid pressure medium at a uniform rate of 95 ± 5 ml per minute against a rubber diaphragm. The rubber diaphragm is fitted to expand through the concentric clamp apertures exerting its force against the specimen set between the two clamps. (In the hand operated machine, this shall correspond to approximately 120 revolutions per minute of a handwheel turning the displacement screw).

METHOD 5122

4.1.3 A diaphragm of molded rubber shall be clamped between the lower clamping plate and the liquid chamber of the apparatus so that, before the diaphragm is stretched by pressure beneath it, the center of its upper surface is below the plane of the clamping surface. The pressure required to raise the free surface of the diaphragm $\frac{3}{8}$ inch (10 mm) above the surface of the diaphragm plate shall be 4.3 ± 0.8 pounds per square inch ($29.6 \text{ kPa} \pm 5.5 \text{ kPa}$). This may be tested by removing the clamping ring and using a bridge gage. The diaphragm shall be inspected before testing for evidence of permanent distortion.

4.1.4 Means shall be provided for stopping, at the instant of rupture of the specimen, any further application of the loading pressure and for holding unchanged the contents of the pressure chamber until the gross bursting pressure and tare diaphragm pressure indicated on the gage have been recorded.

4.1.5 The machine shall be fitted with a pressure gage of the Bourdon tube, maximum reading type, graduated in pounds per square inch (kPa) and accurate throughout the entire range of its scale to within a value equal to 1.0 percent of its maximum capacity. The gage shall be such that the individual readings will be not less than 25 percent, nor more than 75 percent of the total capacity of the gage.

4.2 Any machine that operates on the same principle as the machine described in 4.1 and has coaxial apertures of 1.22 ± 0.03 inches (31 ± 0.76 mm) in diameter in the clamping surfaces may be used.

5. PROCEDURE

5.1 Unless otherwise specified in the procurement document, all tests shall be performed on material conditioned as specified in Section 4 of this Standard.

5.2 The specimen shall be fastened securely between the clamps and the pressure applied until rupture occurs. Care shall be taken not to stretch or distort the cloth when fastening in the clamps. At the instant of rupture, the gross pressure to the nearest scale division shall be recorded. Without relaxing the pressure, the upper clamp shall be completely released. Upon relaxation, the tare pressure of the diaphragm shall be recorded.

5.3 If slippage of the specimen is noted, the result shall be discarded, the clamping pressure increased and another specimen tested.

5.4 Calculation of results. The difference in pounds per square inch (kPa) between the gross bursting pressure and the tare pressure of the diaphragm shall be the bursting strength of the specimen.

METHOD 5122

6. REPORT

6.1 The diaphragm bursting strength of the sample unit shall be the average of the results obtained from the specimens tested and shall be reported separately in pounds per square inch (kPa) to the nearest scale division on the pressure gage.

6.2 Each individual value used to calculate the average shall also be reported.

NOTE: A diaphragm bursting machine of the type described in this method may be obtained from B. F. Perkins & Son, Inc., Holyokes, MA 01040 and the E. J. Cady Company, 654 N. Harlem Avenue, River Forest, IL 60305.

STRENGTH OF CLOTH, TEARING;

FALLING-PENDULUM METHOD

1. SCOPE

1.1 This method is intended for determining the average force required to propagate a tear starting from a cut, in treated or untreated cloths including those heavily sized, coated or resin-treated.

2. TEST SPECIMEN

2.1 Unless otherwise specified in the procurement document, the specimen shall be of sufficient size to provide a basic rectangular test specimen 4 inches (101.6 mm) long by 2-1/2 inches (63.5 mm) wide along with additional fabric at the top edge of the specimen to insure that the last yarns being torn during the test are prevented from ravening. The critical dimension is the 43.0 ± 0.15 mm which is to be torn during the test. Use of a cutting die or a template having the shape and dimensions shown in Figure 5132A is recommended. The long dimension of the specimen shall be parallel to the warp yarns for warp tests and parallel to the filling yarns for filling tests. No two specimens for warp test shall contain the same warp yarns nor shall any two specimens for filling test contain the same filling yarns. No selvage shall be included in the specimen.

3. NUMBER OF DETERMINATIONS

3.1 Unless otherwise specified in the procurement document, five specimens from each of the warp and filling directions shall be tested from each sample unit.

4. APPARATUS

4.1 Falling pendulum (see Fig. 5132B). The falling pendulum apparatus commonly known as Elmendorf Tear Tester provides for holding the specimen with two clamps, one stationary and the other moveable, and for tearing it by the fall of the pendulum due to the force of gravity. The basic tester has a capacity of 0 to 1600 g (0 to 16 N) and is provided with two augmenting weights, the NBS Augmenting Weight which increases the capacity from 1600 g to 3200 g (16 N to 32 N), and the Textile Augmenting Weight which further increases it to 6400 g (64 N). Heavy duty instruments with higher capacities are also available. The instrument includes the following parts.

4.1.1 Stationary clamp.

METHOD 5132

4.1.2 Moveable clamp. Moveable clamp, carried on a pendulum formed by a sector of a circle free to swing on a ball-bearing.

4.1.3 Sector shaped pendulum. Sector shaped pendulum, carrying a circumferential scale graduated to directly read the tearing force. The pendulum section has a cut out in the region adjacent to the clamp so that the specimen does not rub against the sector during test.

4.1.4 Sector release. A sector release for holding the pendulum in a raised position during the mounting of the specimen and to permit it to fall through the force of gravity.

4.1.5 Pointer and pointer-stop. Pointer and pointer-stop for registering the maximum arc through which the pendulum swings when released. The pointer is mounted on the same axis as the pendulum with constant friction just sufficient to stop the pointer at the highest point reached by the swing of the sector. The adjustable pointer-stop provides means for setting the zero of the instrument.

4.1.6 Knife. Knife, mounted on a stationary post for initial slitting of the specimen. It is centered between the clamps and adjusted in height so the tearing distance is 43.0 ± 0.15 mm.

4.2 Cutting die or template. Any cutting die or template having essentially the shape and dimensions shown in Fig 5132A can be used.

5. PROCEDURE

5.1 Unless otherwise specified, the specimens tested shall be conditioned under standard conditions described in section 4 of this Standard.

5.2 The pendulum shall be raised to the starting position and the pointer-set against its stop. The specimen shall be placed securely in the clamp so that it is well centered with the bottom edge carefully set against the stops and so that the upper edge is parallel to the top of the clamps and the widthwise yarns are exactly perpendicular to them. A slit shall be made with the knife blade extending from the bottom edge of the specimen in such a way that it leaves 43.0 ± 0.15 mm of the fabric to be torn. Since the reliability of the results depends greatly on the accuracy of the 43 mm distance, it shall be periodically checked using a paper specimen cut from coordinate paper and measuring the distance under magnification.

5.3 The sector release shall be depressed as far as it will go thus releasing the pendulum. The release shall be held down until after the tear is completed and the pendulum shall be caught by hand on the return swing without disturbing the position of the pointer. The force required to tear the specimen shall be read from the scale to the nearest division.

METHOD 5132

5.4 Readings obtained where the specimen slips in the jaw or where the tear deviates more than 10 mm away from the projection of the initial slit shall be rejected.

5.5 The machine when used for a given specimen shall be of such capacity that the force required to tear the specimen is between 15 and 85 percent of the rated capacity.

5.6 Calculation of results. The average of the 5 specimens in grams or newtons shall be calculated in each direction. When the requirements are specified in customary pound units the average tearing force shall be converted to pounds by using an appropriate factor in each direction.

6. REPORT

6.1 The tearing strength shall be the average tearing force obtained from the 5 specimens tested in each of the warp and the filling directions, and shall be reported separately in grams, newtons or pounds as required in the procurement document to the nearest 1 g, 0.1 N or 0.1 pound.

6.2 Each individual value used in expressing the final result shall also be reported.

7. NOTES

7.1 A pendulum apparatus of the type described in this method is manufactured by Thwing-Albert Instrument Co., 10960 Dutton Road, Philadelphia, PA 19154.

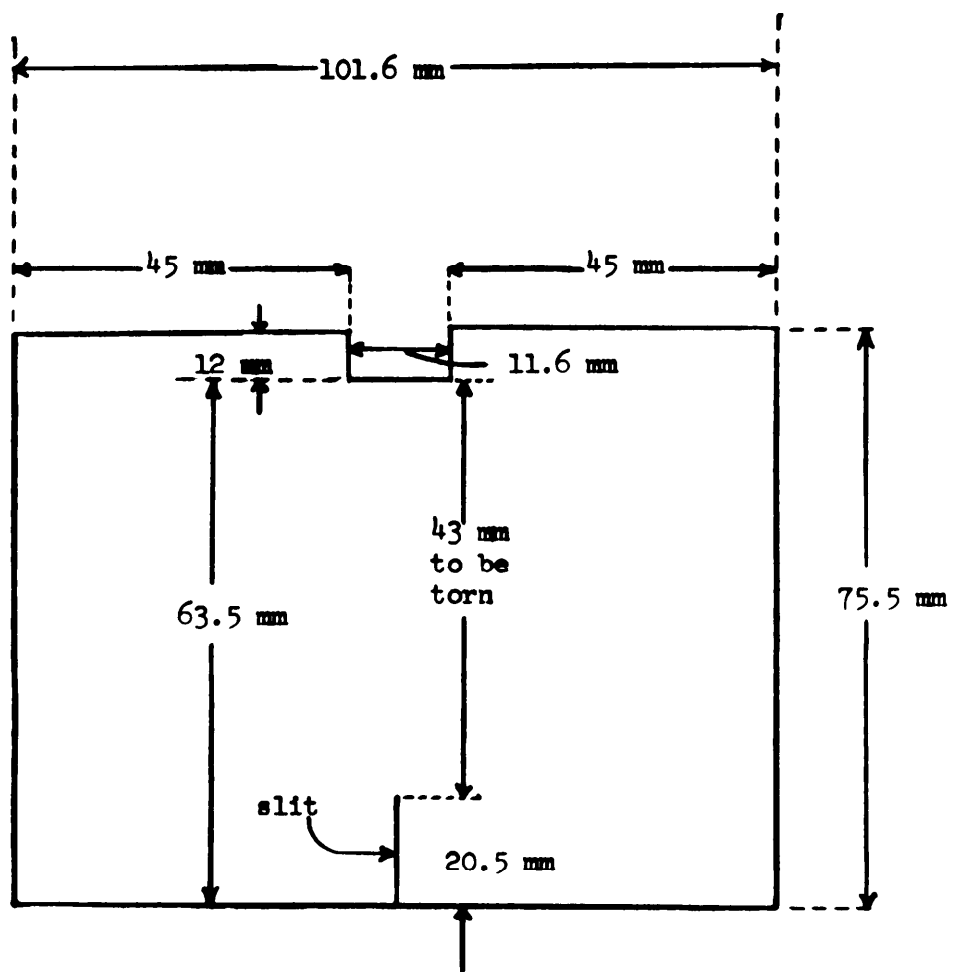

FIGURE 5132A

ELMENDORF TEAR TEST MACHINE

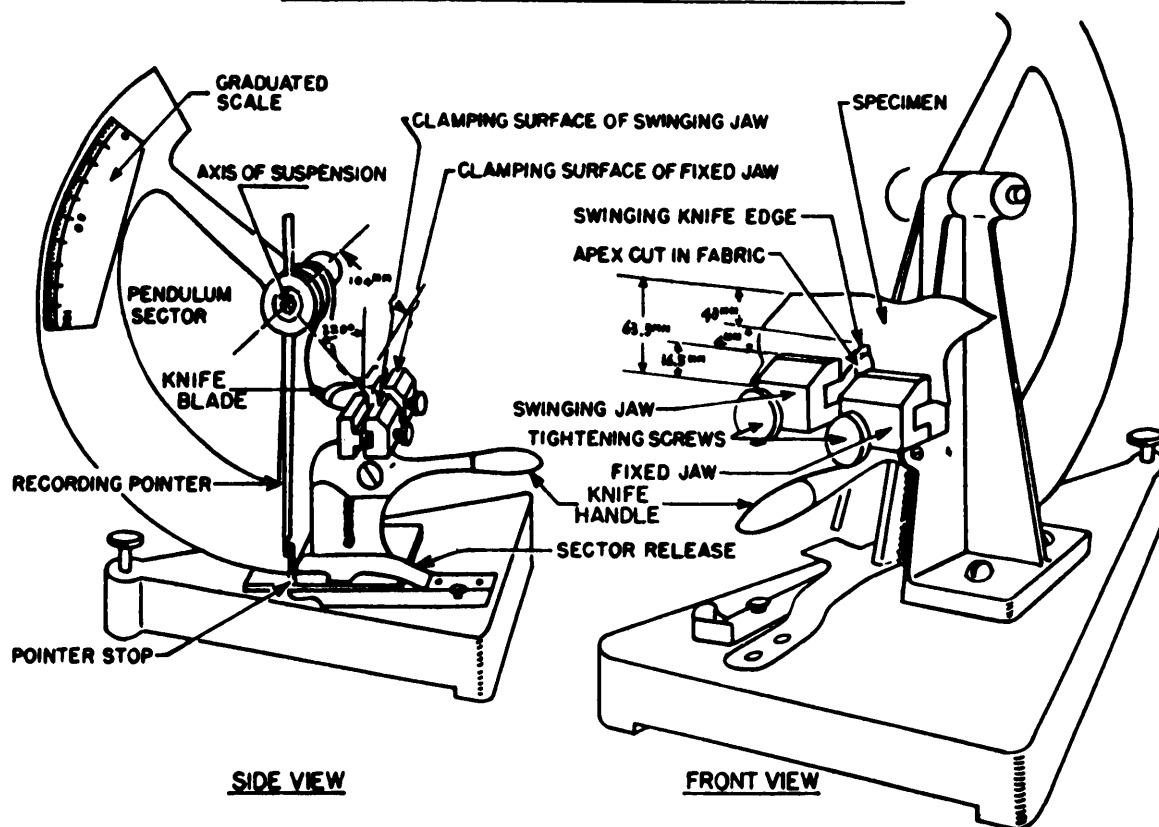

FIGURE 5132B

METHOD 5134
July 20, 1978

STRENGTH OF CLOTH, TEARING; TONGUE METHOD

1. SCOPE

1.1 This method is intended for determining the tearing strength of woven cloth which has approximately the same tearing strength in both the warp and filling directions.

2. TEST SPECIMEN

2.1 Unless otherwise specified in the procurement document, the specimen shall be a rectangle of cloth 3 by 8 inches (76 by 203 mm). No selvage shall be included in the sample tested.

3. NUMBER OF DETERMINATIONS

3.1 Unless otherwise specified in the procurement document, five specimens from each of the warp and filling directions shall be tested from each sample unit.

4. APPARATUS AND METHOD CITED

4.1 Apparatus.

4.1.1 Testing machine as described in Method 5100, except for the following:

4.1.1.1 The face of the jaws shall measure 1 inch (25 mm) by 2 inches (51 mm) or more with the long dimension perpendicular to the direction of application of the load.

4.1.1.2 All machine attachments for determining maximum loads shall be disengaged during "this test."

4.2 Method cited.

Method 5100, Strength and Elongation, Breaking of Woven Cloth; Grab Method.

5. PROCEDURE

5.1 Preparation of specimen. The short distance of the specimen shall be parallel to the warp yarns for the warp tests and parallel to the filling yarns for the filling tests. No two specimens for warp tests shall contain the same warp yarns, nor shall any two specimens for the filling tests contain the same filling yarns. A 3-inch (76 mm) cut shall be made at the center of and perpendicular to a short side of the specimen forming tongues or cut strips.

METHOD 5134

5.2 The machine, when used for a given specimen, shall be of such capacity that the maximum force required to tear the specimen is not greater than 85 percent or less than 15 percent of the rated capacity.

5.3 The specimen shall be centered in the machine with 1 tongue or cut strip specimen in each clamp. The machine shall tear a distance of 3 to 4 inches (76 mm to 102 mm). The machine shall be started, and the force necessary to tear the cloth shall be observed by means of an autographic recording device.

5.4 If a specimen slips between the jaws, breaks, or tears in a direction other than that of the original cut, or if, for any reason attributable to faulty technique, an individual measurement falls markedly below the average test result for the sample unit, such a result shall be discarded and another specimen shall be tested.

6. REPORT

6.1 The tearing strength of the test specimen shall be the average of the 5 highest peak loads of resistance (not including the original peak) registered during the separation of the tear. The tearing strength of the sample unit shall be the average of the results obtained from the 5 specimens tested in each of the warp and filling directions, and shall be reported to the nearest 1 pound (to the nearest 1 N).

6.2 Each individual tear strength value used to calculate the average shall also be reported.

STIFFNESS OF CLOTH , DIRECTIONAL; HANGING HEART LOOP METHOD

1. SCOPE

1.1 This method is intended for determining the direction flex-stiffness of cloth and is especially applicable where fabrics are to be tested at extreme temperatures as well as at normal temperatures. It is also applicable to extremely pliable fabrics.

2. TEST SPECIMEN

2.1 The specimen shall be a rectangle of cloth 10 inches (254 mm) by 1 inch (25 mm) with the long dimension parallel to the yarns to be tested. The specimens shall be cut from the smoothest area possible which has not been previously folded or in any manner deformed.

3. NUMBER OF DETERMINATIONS

3.1 Unless otherwise specified in the procurement document, ten specimens from each of the warp and filling direction shall be tested from each sample unit 1

4. APPARATUS

4.1 Flat bar. Flat bar, 1/8 inch (3 mm) thick, about 3/4 inch (19 mm) wide, and 12-1/2 inches (318 mm) long, mounted horizontally 12 inches (305 mm) above the platform base (see Figure 5200).

4.2 Scale graduated in 1/32 inch (1 mm).

4.3 Cellulose tape, 1/2 inch (13 mm) wide.

4.4 Suitable timing device.

5. PROCEDURE

5.1 Unless otherwise specified in the procurement document, the specimens shall be conditioned and tested under Standard Atmospheric Conditions as specified in Section 4 of this Standard.

5.2 A strip of cellulose tape shall be cut 3 inches (76 mm) in length and placed crosswise on one end of the specimen as shown in Figure 5200. Care shall be taken that the end of the specimen is even with the edge of the tape and that it is not unduly deformed in handling. The inner edge of the tape shall be mounted on one side of the bar even with the upper

METHOD 5200

edge of the bar and with the surface of the cloth flush against the bar. The other end of the specimen shall then be brought under the bar and fastened as above to the opposite side of the bar. In this manner a loop shall be formed, whose plane is perpendicular to the length of the suspension bar.

5.3 The distance from the top of the bar to the lowest point of the heart-shaped loop shall be measured 1 minute after the specimen has been placed in this position. The measurements shall be made to the nearest 1/32 inch (1 mm).

5.4 One-half of the required number of specimens from each of the warp and filling directions from each sample unit shall be tested with the same surface of the cloth on the inside of the loop. The other half of the specimens from each of the warp and filling directions shall be tested with the opposite side of the cloth inside the loop.

5.5 The distance from the top of the bar to the lowest point of the heart-shaped loop is an inverse measure of the stiffness of the specimen.

6. REPORT

6.1 The stiffness of the sample unit shall be the average of the results obtained from the specimens tested in each of the warp and filling directions and shall be reported separately to the nearest 1/32 inch (1 mm) 1

6.2 Each individual value used to calculate the average shall also be reported.

DIRECTIONAL STIFFNESS HANGING LOOP APPARATUS

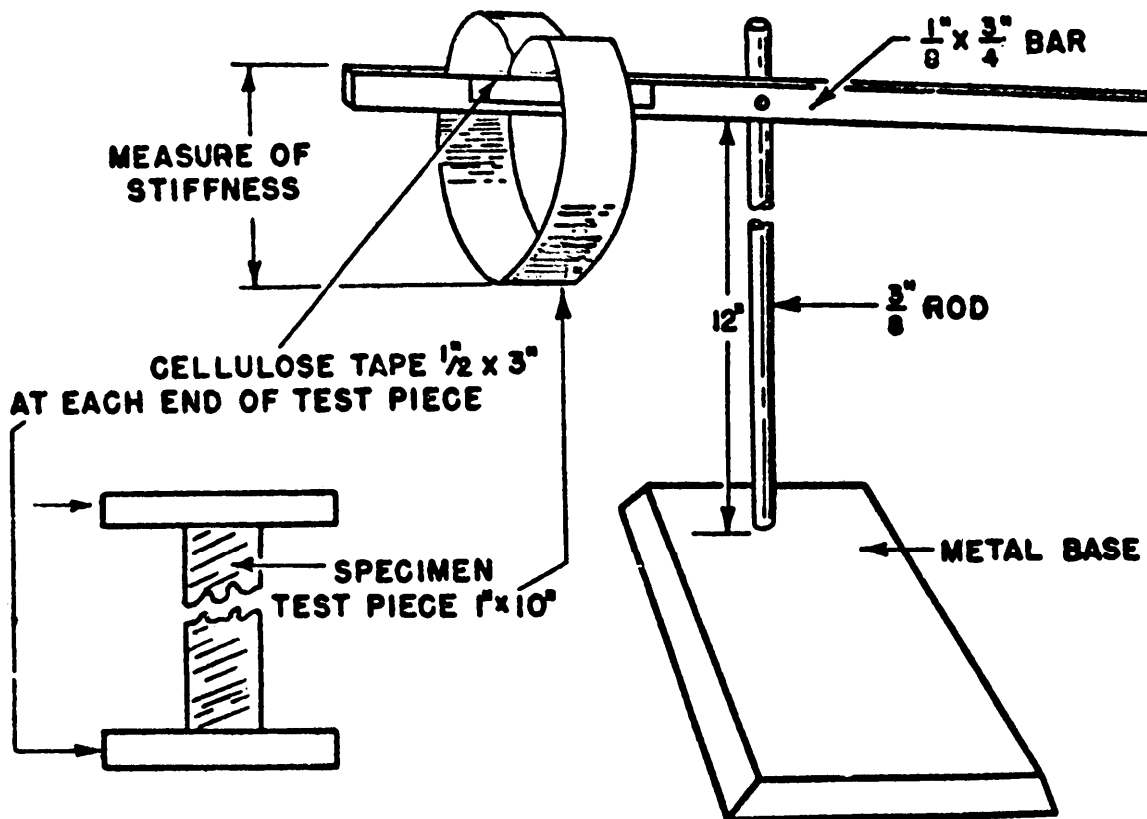

FIGURE 5200

STIFFNESS OF CLOTH, DIRECTIONAL; CANTILEVER BENDING METHOD

1. SCOPE

1.1 This method is intended for determining the directional flex-stiffness of cloth by employing the principle of cantilever bending of the cloth. Small differences in stiffness may be determined by this method, but it is not well suited for testing extremely pliable fabrics.

2. TEST SPECIMEN

2.1 Unless otherwise specified in the procurement document, the specimen shall be a rectangle of cloth 2 inches by 1 inch (51 mm by 25 mm) with the long dimension parallel to the yarns to be tested. The specimen shall be cut from the smoothest area possible which has not been previously folded or in any manner deformed.

3. NUMBER OF DETERMINATIONS

3.1 Unless otherwise specified in the procurement document, ten specimens in each of the warp and filling directions shall be tested from each sample unit.

4. APPARATUS (see Figure 5202)

4.1 Specimen vise. Specimen vise, "V", at least 1 inch (25 mm) wide, to which the pointer indicator "I₂" is attached, and which can be rotated in a clockwise direction alternately by means of a hand crank or motor about the point 0, at a rate of 60 degrees per minute.

4.2 Pendulum weighing system. Pendulum weighing system, including an angular deflection scale pointer indicator "I₁", adjustable bending plate "Q" for contacting the free end of the specimen, and a series of detachable weights "M" calibrated to the pendulum system. This system shall be pivoted for nearly frictionless rotation about the point 0.

4.3 Angular deflection scale. Angular deflection scale calibrated in degrees of arc which will indicate the difference in the angles through which the vise has been turned and the load of the pendulum has been deflected.

4.4 Fixed load scale. Fixed load scale which measures the deflection θ of the pendulum system, calibrated to read directly $100 L \sin \theta$, where L is the distance between the center of rotation 0, and the center of the applied load M . Thus, M times the load scale reading divided by 100 gives the bending moment directly.

METHOD 5202

5. PROCEDURE

5.1 Unless otherwise specified in the procurement document, the specimens shall be conditioned and tested under Standard Atmospheric Conditions as specified in Section 4 of this Standard.

5.2 The machine shall be placed in test position and leveled. A suitable moment weight shall be placed on the pendulum and then, if necessary, the load scale adjusted to indicate zero. The moment weight applicable to a given cloth may be determined by trial. The bending plate shall be set to a 1/2 inch (13 mm) span between the edge of the vise and the nearest edge of the bending plate. The motor shall be started and kept running throughout the test since its vibration minimizes friction effects in the weighing system. However, during the initial portion of the test, it shall be disengaged.

5.3 The specimen shall be clamped firmly in the vise and the long edge parallel to the face of the dial plate. Care shall be taken that the specimen is not unduly deformed in handling. The face surface of the specimen (weave face, finished side, coated side, etc.) shall be placed upward in the vise.

5.4 Sufficient load shall be applied to the specimen by turning the hand crank to show a 1-percent load reading. The angle pointer shall then be set to zero and subsequent load readings reduced by one division.

5.5 The motor engaging lever shall be held down and the load scale readings taken at 10 degree intervals up to 90 degree deflection or until the angle of bend specified for the test is reached.

5.6 Calculation of results.

5.6.1 The stiffness shall be calculated in one or more of the following ways as specified in the procurement document:

5.6.1.1 Bending moment in.-lb (N·m) - The bending moment shall be that applied with the specimen is bent to a 60 degree angular deflection and shall be calculated as follows:

$$\text{Bending moment, inch-pounds} = \frac{\text{load scale reading} \times \text{moment weight}}{100}$$

$$\text{Bending moment, N·m} = \text{Bending moment, in.-lb.} \times 0.113$$

METHOD 5210

5.2 Immediately after removing the weight, the creased specimen shall be hung over the mounted wire and allowed to recover for 3 minutes. The crease measurement shall be the length of the vertical projection of the fabric ends on the graduated scale.

5.3 Calculation of results.

5.3.1 The crease recovery shall be calculated as follows:

$$\text{Crease recovery, percent} = 1 - \left(\frac{O-C}{O} \right) \times 100$$

Where:

O = Original measurement.

C = Measurement after crease.

6. REPORT

6.1 The crease resistance of the sample unit shall be the average of the results obtained from the specimens tested in each of the warp and filling directions and shall be reported separately to the nearest 1.0 percent.

6.2 Each individual value used to calculate the average shall also be reported.

DIRECTIONAL STIFFNESS CANTILEVER BENDING APPARATUS

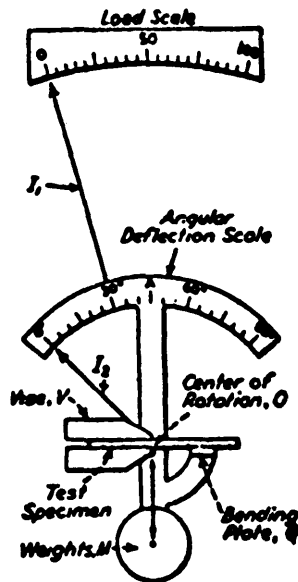

FIGURE 5202

STIFFNESS OF CLOTH, DIRECTIONAL; SELF-WEIGHTED CANTILEVER METHOD

1. SCOPE

1.1 This method is intended for determining the directional flex-stiffness of cloth. It is applicable where cloth is to be tested at extreme temperatures as well as under standard conditions.

2. TEST SPECIMEN

2.1 The specimen shall be a rectangle of cloth 1-1/4 inches (32 mm) by 6 to 12 inches (152 to 305 mm) with the longer dimension parallel to the direction of the yarns being tested. The specimen shall be cut with clean straight edges. The specimen shall be selected from material which has not been creased or folded in any manner.

3. NUMBER OF DETERMINATIONS

3.1 Unless otherwise specified in the procurement document, five specimens from each of the warp and filling directions shall be tested from each sample unit.

4. APPARATUS (Figure 5204)

4.1 Two rolls, each one inch in diameter and approximately 4.25 inches (108 mm) in length held together by spring pressure, one of which shall be turned slowly by means of a worm drive. The line of contact of the rolls shall coincide with the axis of rotation of the supporting framework.

4.2 Pointer attached to the framework to indicate the relative angular position of the framework with respect to a rotating circular scale calibrated in degrees.

4.3 Slow gear adjustment for convenient rotating of the framework and rolls clockwise and counter-clockwise. The instrument shall be adjusted to operate at a uniform rate of one revolution per minute + 5 seconds.

4.4 Scale, graduated to 0.1 mm and attached to a metal base, suitable for measuring the extended length of the mounted specimen, i.e., the distance from the nip of the rolls to the end of the specimen above the rolls.

5. PROCEDURE

5.1 Testing will be performed under standard conditions in accordance with Section 4 of this standard and other conditions as may be specified in the applicable procurement document.

METHOD 5204

5.2 The measure of directional flex-stiffness shall be the length of the specimen remaining above the nip of the rolls which, when the test instrument is rotated clockwise and counter-clockwise through $90 \text{ degrees} \pm 2 \text{ degrees}$, just falls to the left and right of the line perpendicular to the nip of the rolls. It is this length of specimen which yields the flexibility criteria being measured. The specimen shall be considered to have fallen to the right or left when the specimen, during the course of clockwise and counter-clockwise rotation, passes across the line perpendicular to the nip of the rolls as indicated by the pointer fastened to the rotating framework.

5.3 This length of the specimen shall be determined as follows:

5.3.1 Initial adjustment of test instrument.

5.3.1.1 The apparatus shall be placed in the test position and leveled with the axis of the clamping surface (nip of the rolls) horizontal and the pointer, fastened to the rotating framework, in the vertical position.

5.3.1.2 One end of the specimen shall be inserted between the rolls with the lengthwise edges of the specimen perpendicular to the nip of the rolls.

5.3.1.3 The specimen shall be positioned and shall be of sufficient length to allow it to bend to the left of the line perpendicular to the nip of the rolls, which when the apparatus is rotated, with continuous uniform motion in the clockwise direction it will fall to the right of the perpendicular line.

5.3.1.4 At the point the specimen falls to the right, the instrument shall be stopped and the adjustable circular scale moved to make the zero position on the scale coincide with the pointer fastened to the rotating framework. The instrument shall then be rotated with continuous uniform motion $\pm 2 \text{ degrees}$ from this point in the counter-clockwise direction. The specimen should not fall to the left of the perpendicular line at this point.

5.3.1.5 If the specimen falls to the left then the instrument shall be rotated in the clockwise direction until the pointer is vertical. The specimen shall be shortened and reset with a bend to the left and the above procedure in 5.3.1.4, repeated.

5.3.2 Determination of flex-stiffness.

5.3.2.1 After initial adjustment the instrument is rotated until the pointer is vertical. The length of the specimen is shortened by a small increment, set with a bend to the left and the instrument is rotated with continuous uniform motion clockwise until the specimen falls to the right of the perpendicular line. The instrument is stopped and the zero position of the adjustable scale is made to coincide with the pointer. The instrument is rotated, with continuous uniform motion, in the counter-clockwise direction $90 \pm 2 \text{ degrees}$ when the instrument is immediately reversed in the clockwise direction and rotated, with continuous

METHOD 5204

uniform motion, to return the point to zero. The specimen shall have fallen immediately to the left of perpendicular at 90 ± 2 degrees and shall fall immediately to the right of the perpendicular as the pointer reaches zero.

5.3.2.2 If the specimen does not fall to the left when it is rotated the required 90 ± 2 degrees in the counter-clockwise direction the pointer is rotated to the vertical position, the specimen is shortened another small increment and the procedure in 5.3.2.1 repeated.

5.3.2.3 When the specimen has reached the length such that it falls to the left and right of the line perpendicular to the nip of the rolls the instrument is stopped with the pointer in a vertical position.

5.3.2.4 Without tension the specimen above the rolls shall be extended and the length measured from the nip of the rolls to the end of the extended specimen, to the nearest mm.

5.3.3 The length of the extended specimen is recorded as the directional flex-stiffness of the specimen.

6. REPORT

6.1 The directional flex-stiffness of the sample unit tested shall be reported as the average of the specimens tested in each of the warp and filling directions.

6.2 Each individual value used to calculate the average shall also be reported.

7. NOTES

7.1 A self-weighted cantilever machine of the type described in this method is manufactured by Thwing-Albert Instrument Company, 10960 Dutton Road, Philadelphia, PA 19154. It is identified as the Clark Paper Softness-Stiffness Tester .

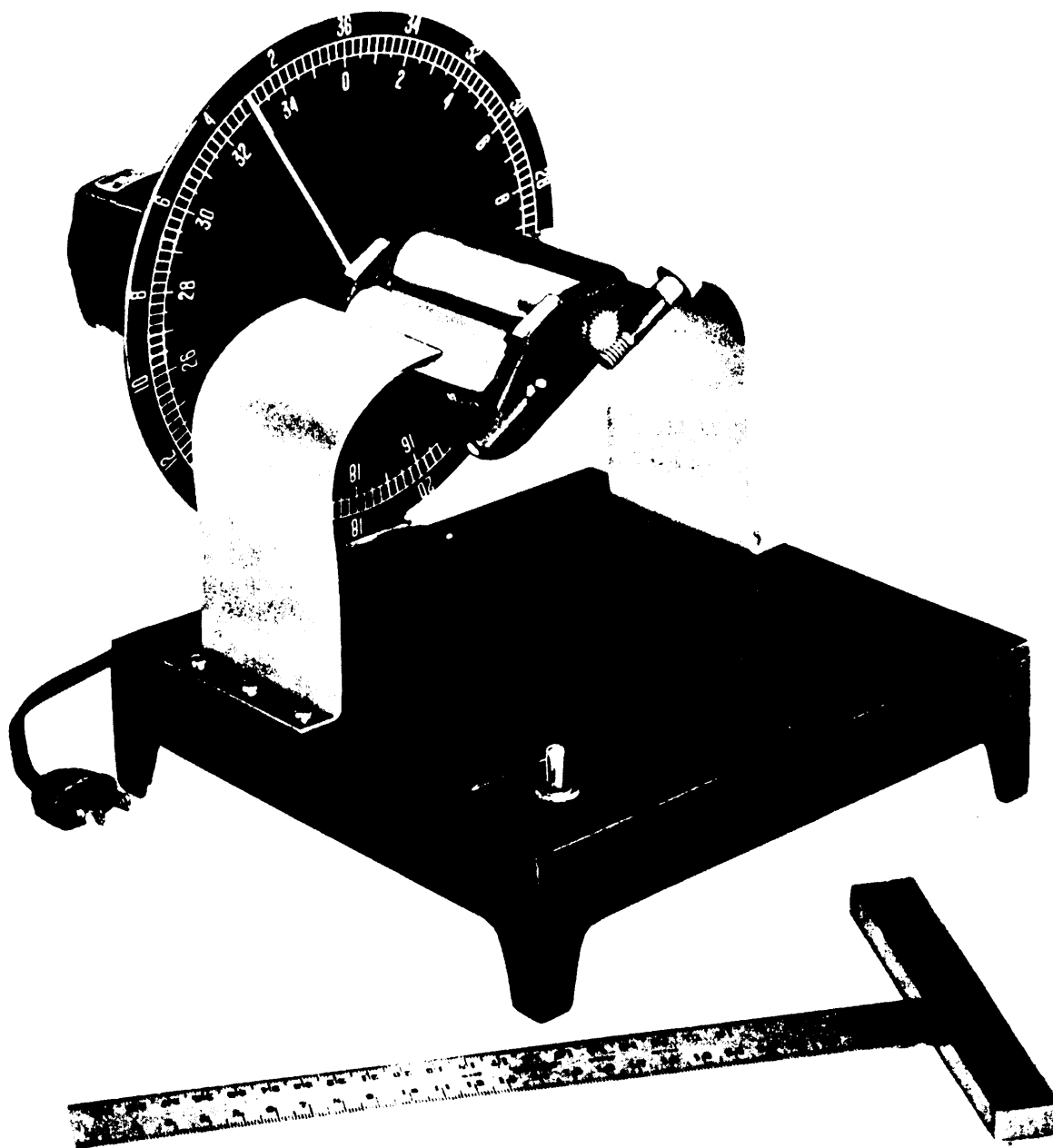

FIGURE 5204

FED. TEST METHOD STD. NO. 191A

STIFFNESS OF CLOTH, DRAPE AND FLEX;
CANTILEVER BENDING METHOD

1. SCOPE

1.1 This method is intended for determining the drape stiffness (bending length) and flex (flexural rigidity) of cloth by employing the principle of cantilever bending of the cloth under its own weight. It is especially applicable where cloths are to be tested at extreme temperatures as well as at standard conditions. This method is not considered suitable for testing knitted cloths or very soft lightweight woven cloths. The method is not recommended for cloths when the specimen twists more than 45 degrees. Method 5200 is preferred for cloths in which the specimen twists for more than 45 degrees.

2. TEST SPECIMEN

2.1 The test specimen shall be a rectangular strip of cloth $6 \pm 1/2$ inches (152 ± 13 mm) long and 1 inch (25 mm) wide, prepared as described in 5.2.

3. NUMBER OF DETERMINATIONS

3.1 Unless otherwise specified in the procurement document, five specimens from each of the warp and filling directions shall be tested from each sample unit.

4. APPARATUS

4.1 The apparatus shall consist essentially of a horizontal platform, an indicator, a weight or specimen clamp, scale, and pointer, as shown in figure 5206.

4.1.1 Horizontal platform. The horizontal platform shall be not less than $1-1/2$ by 6 inches (38 by 152 mm) in area and has a smooth, low-friction, flat surface such as polished metal or plastic. A leveling bulb or other means for determining that the platform is horizontal before conducting a test shall be incorporated in the platform.

4.1.2 Indicator. The indicator is inclined at an angle of $41-1/2$ degrees below the plane of the surface of the platform. This should consist of 2 guidelines not less than $1-1/4$ inches (32 mm) apart, so that the tip of the specimen can pass between them. It may be formed by the end of a hollow stand

METHOD 5206

on which the horizontal platform is mounted. A rectangular opening in the sloped end of the hollow stand makes it possible to measure cloths which twist when cut into strips. The length depends on the range of stiffness to be measured. The apparatus may be designed with a longer indicator than is necessary for a 6-inch (152 mm) specimen, or an extension may be used.

4.1.3 Weight. The weight consists of a metal bar not less than 1 by 6 inches (25 by 152 mm) in area and about 1/8 inch (3 mm) thick. In conducting the test, the weight is placed on the specimen so that the leading edges of the specimen and bar coincide and slide out with the specimen.

4.1.4 Specimen clamp. A specimen clamp consists of a flat metal base plate 1 inch (25 mm) wide and approximately 8 inches (203 mm) long with a reference line or pointer located 6 inches (152 mm) from the leading edge and at right angles to the long dimension, and a flat metal spring for holding the specimen against the base plate. A hand grip for moving the specimen and clamp along the top surface of the horizontal platform may be used (see figure 5206).

4.1.5 Measurement scale and pointer. The scale and pointer are provided for measuring the overhang of the specimen. The scale may be attached to the platform and the pointer to the weight or specimen holder. The scale should be a 6 inch (152 mm) scale with 0.1 inch (2.54 mm) graduation coincident with the leading edge or edge of the indicator when attached to the platform.

4.2 Analytical or calibrated balance. Analytical or calibrated balance capable of weighing the specimen to an accuracy of 0.01 g.

5. PROCEDURE

5.1 Unless otherwise specified in the procurement document, all tests shall be performed under standard conditions in accordance with Section 4 of this Standard.

5.1.1 Unless otherwise specified in the procurement document, the face side of the cloth shall be on the outside of the curvature when tested.

5.2 Preparation of specimen. The long dimension of the cloth shall be parallel to the warp direction for warp tests and parallel to the filling direction for filling tests. For some material, a longer specimen may be required to obtain a satisfactory reading on the apparatus (see 5.6). The specimen shall be accurately cut from a smooth area of the cloth which has not previously been folded or deformed in any manner. The specimen should be handled as little as possible both before and during the test.

METHOD 5206

5.3 The apparatus shall be on a table in such a reamer that the platform and inclined reference lines are level and at eye height.

5.4 When a specimen clamp is used, the specimen shall be placed lengthwise in the clamp with the side up that is to be tested, so that the clamped end of the specimen is exactly even with the reference line on the base of the clamp. With the normal 6 inch (152 mm) specimen, the alignment may alternately be made by adjusting the specimen so that the free end of the specimen and the front end of the clamp coincide. The specimen clamp and specimen shall be placed on the platform so that the reference line on the clamp coincides with the zero point on the scale.

5.5 When the weight is used, the specimen shall be placed on the platform with the weight on top of it so that the leading edges coincide.

5.6 The clamp or weight together with the specimen shall be moved slowly and steadily against the ruler or pointer until the bottom of the free edge of the specimen drops to the 41-1/2 degree indicator when viewed parallel to the surface of the slope or guide lines. A reading shall be taken from the scale to the nearest 0.05 inch (1.27 mm). For a 6-inch (152 mm) specimen this is the overhang of the specimen. For a longer specimen, the length in excess of 6 inches (152 mm) is added to the scale reading to obtain the length of overhang.

5.6.1 If the specimen has a slight tendency to twist, the reading shall be taken when the midpoint of the leading edge is at the 41-1/2 degree angle.

5.7 When the 6-inch (152 mm) specimen does not bend sufficiently to permit a reading, a longer specimen (see 5.2) shall be used. When the longer specimen is used, it is necessary to increase the length of the indicator sufficiently to accommodate the longer specimen.

5.8 Determination of weight of cloth (ounces per square yard) (g/m²). The specimen shall be weighed to the nearest 0.01 g on an analytical balance or directly on a calibrated balance.

5.9 Calculation of results.

$$5.9.1 \text{ Ounces per square yard} = \frac{\text{Weight (g)} \times 45.72}{\text{Length (in)} \times \text{width (in)}}$$

$$\text{g/m}^2 = \frac{\text{Weight (g)} \times 1\,000\,000}{\text{Length (mm)} \times \text{width (mm)}}$$

METHOD 5206

5.9.2 The drape stiffness (bending length), c , inches shall be one-half of the length of the overhang of the specimen when it reaches the 41-1/2 degree slope.

Drape stiffness, c , centimeters = Drape stiffness, inches \times 2.54

5.9.3 Flex stiffness (flexural rigidity), G , in inch-pounds shall be calculated as follows:

$$G = c^3 \times W \times 0.482 \times 10^{-4}$$

Where: c = Drape stiffness, inches, (see 5.9.2)

W = Weight of cloth in ounces per sq. yd., (see 5.8 and 5.9)

Flex stiffness, G , milligram-centimeters = G , inch-pounds \times 1.152 \times 10⁶

6. REPORT

6.1 Unless otherwise specified in the procurement document, the drape or flex stiffness of the sample unit shall be the arithmetic average of the results obtained from the specimens tested in each of the warp and filling directions, and shall be reported separately.

6.1.1 Each individual value used to calculate the average shall also be reported.

6.1.2 When a single drape or flex stiffness value for combined warp and filling directions is specified in the procurement document, it shall be reported as the geometric mean of the two arithmetic averages for the warp and filling directions as follows:

$$G_o = \sqrt{G_w \times G_f}$$

G_o = Overall drape or flex stiffness.

G_w = Average warp drape or flex stiffness.

G_f = Average filling drape or flex stiffness.

6.2 Drape stiffness of the sample unit shall be reported to the nearest 0.01 inch (0.25 mm).

6.3 Flex stiffness of the sample unit shall be reported to the nearest 0.1 \times 10⁻⁴ inch-pound.

7. NOTES

7.1 A Drape-Flex Stiffness Tester of the type shown in Figure 5206 may be purchased from J. J. Press, 5788 Eldergardens Street. San Diego, CA 92120.

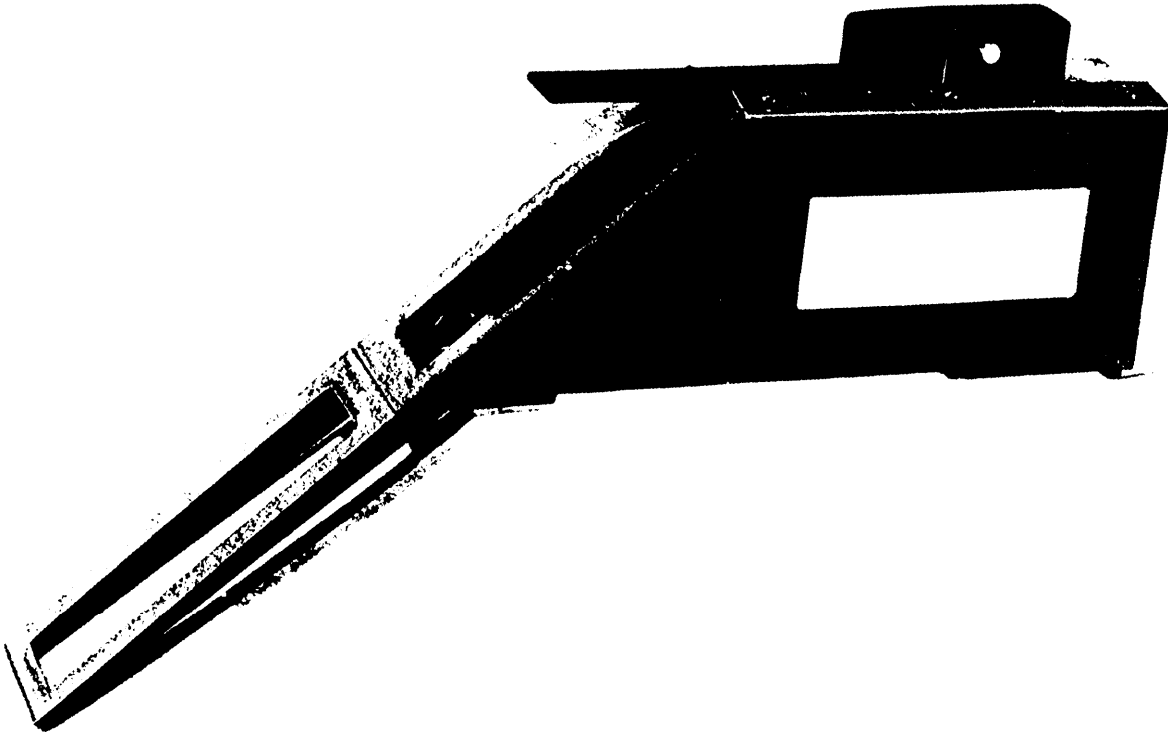

FIGURE 5206 - Stiffness tester.

CREASE RESISTANCE OF CLOTH; COLD PRESS RECOVERY METHOD

1. SCOPE

1.1 This method is intended for determining the resistance of fabrics to creasing which might occur during normal wear.

2. TEST SPECIMEN

2.1 The specimen shall be rectangle of cloth cut accurately 40 mm in length and 10 mm in width. The yarns to be tested shall be parallel to the long dimension of the specimen. The specimen shall not have been previously folded or in any manner deformed.

3. NUMBER OF DETERMINATIONS

3.1 Unless otherwise specified in the procurement document, five specimens in each of the warp and filling directions shall be tested from each sample unit.

4. APPARATUS (see Figure 5210)

4.1 Scale. Scale graduated in increments of 1 mm and mounted on a horizontal surface.

4.2 Fine wire of No. 24 gage American or Brown & Sharp, over 1 inch (25 mm) in length, mounted in a horizontal plane approximately 1 inch (25 mm) above the plane of the scale. The wire shall be parallel to the scale graduations and when viewed from directly above shall cover the zero scale graduation.

4.3 Laboratory tweezers.

4.4 Weight. A 500 g weight with a flat surface of such dimensions that the total weight of 500 g can be applied to the folded specimen.

5. PROCEDURE

5.1 The center of the specimen shall be placed over the wire and allowed to relax for 3 minutes undisturbed by wind, currents or drafts. A center mark prior to mounting may aid in arranging the specimen in a balanced and horizontal specimen on the wire. The original measurement shall be the length of the vertical projection of the cloth ends of the graduated scale. The specimen shall then be folded exactly in half, using tweezers, so as to form a rectangle 20 mm by 10 mm and placed under the flat surface of a 500 g weight for 5 minutes.

METHOD 5202

5.6.1.2 Load scale reading, percent (percentage of the maximum bending moment). The load scale reading, when the specimen is bent to a 60 degree angular deflection, shall be recorded.

5.6.1.3 A plot of the data shall be made on coordinate paper with the "load scale readings" at every 10 degrees up to 90 degrees and the calculated corresponding "bending moment" as the ordinate, and the "angular deflection" as the abscissa.

5.6.1.4 Load, lb (mg) - The pounds (mg) load shall be that applied when the specimen is bent to a 60 degree angular deflection and shall be calculated as follows:

$$\text{Load, lb. (mg)} = \frac{\text{Load scale reading} \times \text{moment weight}}{100 \times 0.5 \text{ in. (12.7 mm)}}$$

6. REPORT

6.1 The stiffness of the sample unit shall be the average of the results obtained from the specimens tested in each of the warp and filling directions, respectively, and shall be reported to the nearest 0.001 lb. (1 mg) for pounds (mg) load, and to the nearest scale division for the load scale reading.

6.2 The report shall include the moment weight, length of span, and specimen dimensions.

6.3 Each individual value used to calculate the average shall also be reported.

7. NOTES

7.1 A cantilever bending machine of the type described in this method is manufactured by the Tinius Olsen Testing Machine Co., 2100 Easton Road, Willow Grove, PA 19090.

APPARATUS FOR DETERMINING GREASE RESISTANCE

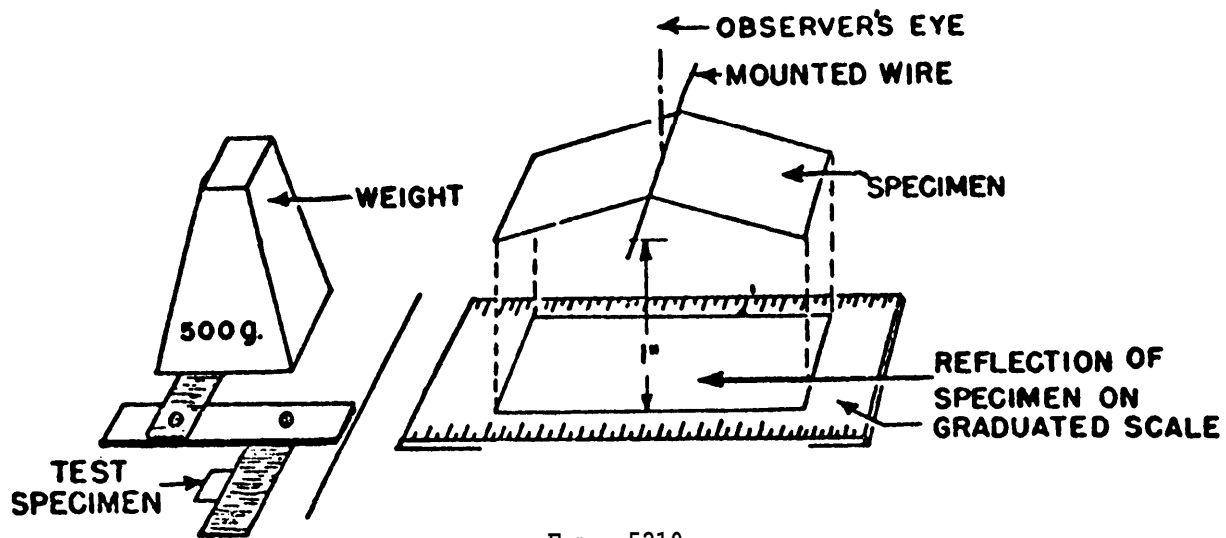

METHOD 5212
July 20, 1978

CREASE RESISTANCE OF CLOTH, ANGLE OF RECOVERY METHOD

1. SCOPE

1.1 This method is intended for determining the recovery of cloth from creasing which might occur during normal wear.

2. TEST SPECIMEN

2.1 The specimen shall be a rectangle of cloth 1-1/2 inches (38 mm) in length, and 1/2 inch (13 mm) in width. The long dimension shall be parallel to the filling direction for filling tests, and parallel to the warp direction for warp tests. The specimen shall not have been previously folded or in any manner deformed.

3. NUMBER OF DETERMINATIONS

3.1 Cloths having a definite face side. Unless otherwise specified in the procurement document, three specimens from each of the warp and filling directions shall be tested from each sample unit.

3.2 Cloths having no definite face side. Unless otherwise specified in the procurement document, six specimens, three on each side of the cloth from each of the warp and filling directions shall be tested from each sample unit.

4. APPARATUS (see fig. 5212)

4.1 Disk and protractor. A disk and a protractor mounted coaxially on a vertical support and free to rotate about a horizontal axis.

4.1.1 The center of the disk and the protractor shall be marked and a vertical guide line shall be drawn on the support from the center mark to the base.

4.1.2 The disk shall be provided with a zero point which will indicate on the protractor the angle formed by the creased specimen when it is mounted on the clamp.

4.2 Clamp. A clamp shall be attached to the face of the disk to support the specimen holder with an adjustment to provide for cloths of different thicknesses.

FED. TEST METHOD STD. NO. 191A

METHOD 5212

4.3 Specimen holder. A specimen holder consisting of 2 superimposed metal leaves of different lengths. The shorter top leaf shall not be greater than 0.007 inch (0.18 mm) in thickness. There shall be a line drawn on it parallel to and exactly 18 mm from the free end.

4.4 Plastic press. A plastic press similar in construction to the specimen holder, except that leaves shall be equal in length but slightly wider.

4.4.1 Plastic platform. A plastic platform constructed of similar plastic 7/8 inch (23 mm) in length and the same width as the press, and permanently attached to the end of the upper jaw of the press.

4.5 Weight. A 1-1/2 pound (0.68 kg) weight of such dimension that its total weight can be applied to the platform.

4.6 Laboratory tweezers.

5. PROCEDURE

5.1 Using the tweezers, one end of the specimen shall be placed between the leaves of the specimen holder directly under the 18 mm mark, and the second end shall be folded over the shorter metal leaf and brought up even with the first end.

5.1.1 Unless otherwise specified, using the tweezers, specimens from cloths with a definite face side shall be placed in the holder so that the face of the cloth is on the outside of the fold. When the cloth has no definite face, duplicate measurements shall be made with each side of the cloth on the outside of the fold.

5.2 The center of the specimen, at which point the crease shall be formed, shall lie 20 mm beyond the end of the shorter metal leaf.

5.2.1 Care shall be taken that the fingers do not touch this region of the cloth.

5.3 The specimen and holder shall then be placed between the jaws of the plastic press with the shorter leaf uppermost and with the jaw to which the platform is attached above and parallel to the longer strip of the holder.

5.3.1 The specimen and holder shall be so positioned that the fold of the specimen shall be approximately 1/8 inch (3 mm) from the inner edge of the platform.

5.4 The press shall then be placed on a flat surface, and a 1-1/2 pound (0.68 kg) weight placed on the platform and allowed to remain for 5 minutes to form a crease in the specimen.

FED. TEST METHOD STD. NO. 191A

METHOD 5212

5.5 The weight shall then be lifted from the press and the specimen older and specimen transferred from the jaws of the press to the clamp on the tester disk.

5.6 The crease shall be located exactly at the spot marking the center of the disk, and the free end of the specimen aligned with the guide line on the vertical support.

5.6.1 The alignment shall be readjusted as the specimen relaxes.

5.7 Unless otherwise specified in the procurement document, the crease angle between the ends of the specimen shall be read from the protractor at the end of 5 minutes.

5.8 Calculation of results.

5.8.1 The crease recovery of the specimen shall be calculated as follows:

$$\text{Crease recovery, percent} = \frac{\text{crease angle (degrees)}}{180 \text{ degrees}} \times 100$$

6. REPORT

6.1 Cloths having a definite face side. The crease recovery of the sample unit shall be the average of the results obtained from the specimens tested in each of the warp and filling directions, and shall be reported separately to the nearest 1.0 percent.

6.2 Cloths having no definite face side. The crease recovery of the sample unit shall be the average of the results obtained from the specimens tested on each side of the warp and filling directions, and shall be reported separately to the nearest 1.0 percent.

6.3 Each individual value used to calculate the average shall also be reported.

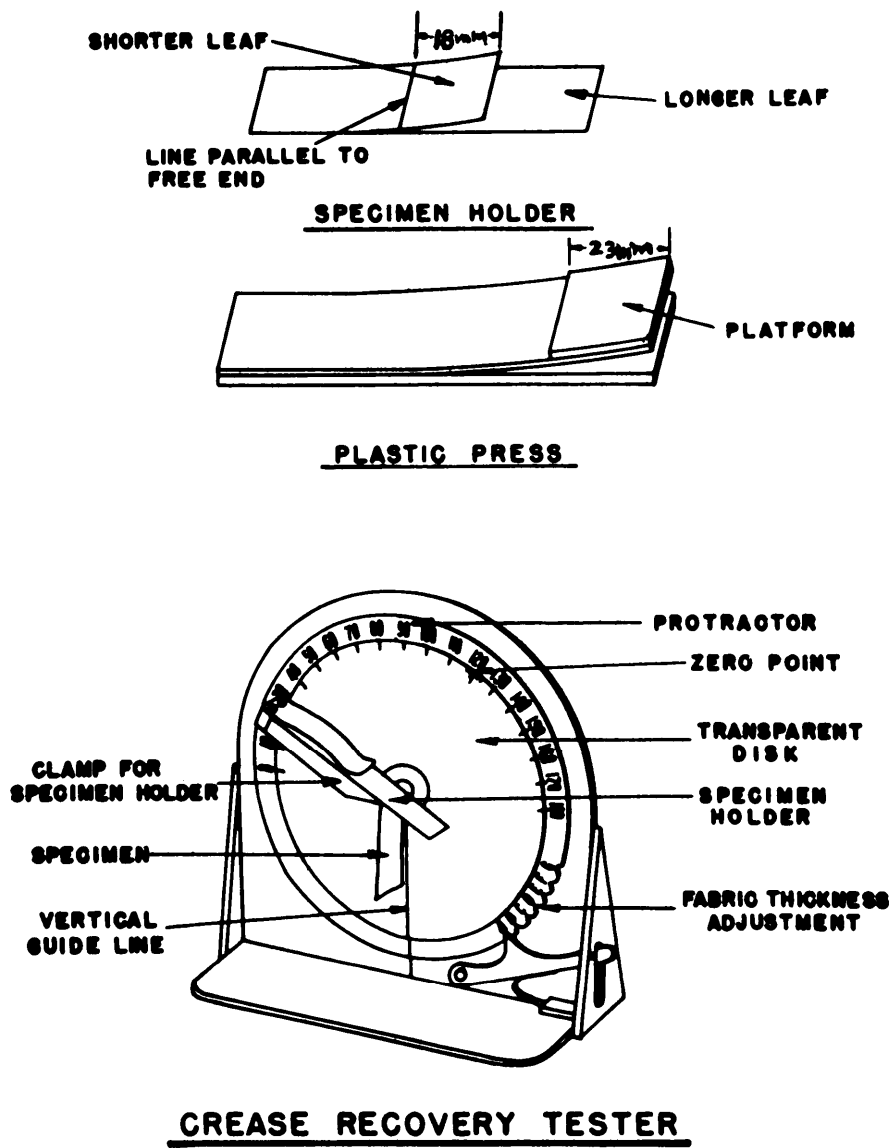

FIGURE 5212

WRINKLE RECOVERY OF FABRICS; APPEARANCE METHOD

1. SCOPE

1.1 This method is intended for evaluating the appearance of textile fabrics after induced wrinkling. This method is useful in evaluating fabrics with wrinkle resistant finishes.

2. TEST SPECIMEN

2.1 The test specimen shall be a rectangle of cloth 11 inches by 6 inches (279 mm by 152 mm) with the long dimension in the warp direction for woven fabrics or wale direction for knitted fabrics. The face of the fabric, if any, shall be identified.

2.2 When a standard sample has been established, one specimen from the standard sample shall be tested along with the specimens from the sample unit.

3. NUMBER OF DETERMINATIONS

3.1 Unless otherwise specified in the procurement document, three specimens shall be tested from each sample unit.

4. APPARATUS

4.1 Wrinkle Tester (see figures 5214A and B).

4.1.1 The Wrinkle Tester (see 7.1) consists of two metal flanges with one of the flanges fixed to a heavy metal base with a vertical shaft at its center. The second flange with a hole at its center is attached to a hollow cylinder, and can be slid down the vertical shaft on the first flange. A pin is attached to the vertical shaft so that the top flange can be locked in a raised position. The pin passes through a slot in the hollow cylinder. The slot is in the shape of a helix around the hollow cylinder so that as the top flange is lowered it makes a half turn from the raised to the lowered position. The top flange assembly is machined to weigh 0.5 ± 0.005 kg (see 7.2). Two steel springs and clamps are provided to enable the specimen to be secured around the flanges.

4.2 Three weights. 1.1 pound (0.5 kg); 2.2 pounds (1.0 kg); 4.4 pounds (2.0 kg).

METHOD 5214

4.3 Lighting equipment for viewing specimens (see figure 5214C)

4.3.1 Lighting equipment shall consist of the following:

4.3.1.1 Two 8-foot (2.44 m) type F96 CW (Cool White) Preheat Rapid Start Fluorescent Lamps (without baffle or glass).

4.3.1.2 One white enamel reflector (without baffle or glass).

4.3.1.3 One general-type swatch mount, spring-loaded, fabricated from light sheet metal (22 ga.).

4.3.1.4 Plywood mounting board 1/4 inch (6 mm), outside dimensions 6 feet by 4 feet (1.8 m by 1.2 m), painted gray to match No. 2 rating on International Gray Scale for Staining.

4.3.1.5 The lighting equipment shall be arranged as shown in Figure 5214C. The overhead fluorescent light shall be the only light source for the viewing board. In addition, to prevent reflected light from the side walls near the viewing board interfering with the evaluation, the side walls shall be painted black or black-out curtains shall be mounted on either side of the viewing board.

4.4 Three Dimensional Durable Press Replicas (see 7.1).

4.5 Stop-Clock.

4.6 Clothes hanger with clips.

5. PROCEDURE

5.1 Unless otherwise specified in the procurement document, the specimens tested shall be conditioned and tested under Standard Atmospheric Conditions in accordance with Section 4 of this Standard.

5.2 The top flange of the wrinkle tester shall be raised and held in position with the locking pin.

5.3 One long edge of the specimen shall be wrapped around the top flange with face side of the specimen on the outside and shall be secured in position using the steel spring and clamp. The ends of the specimen shall be so arranged that they are opposite the opening in the spring clamp.

5.4 The opposite long edge of the specimen shall be wrapped around the bottom flange and secured as described in 5.3.

METHOD 5214

5.5 The specimen shall be adjusted so that it lies smooth without sagging between the top and bottom flanges. Stretching shall be avoided when mounting the specimen.

5.6 The locking pin shall then be withdrawn and the top flange gently lowered until it comes to rest.

5.7 A total of 7.7 pounds (3.5 kg) weight shall be immediately placed on the top flange and the stop-clock set for 20 minutes shall be started.

5.8 After 20 minutes, the weights and the spring clamps shall be removed. The top clamp shall then be raised and locked. The specimen shall be gently removed from the tester so as not to distort any induced wrinkles.

5.9 The shorter edge of the specimen shall be placed under the clips on a clothes hanger with a minimum of handling and shall be allowed to hang vertically in the long direction for 24 hours. The specimens shall then be evaluated.

5.10 Evaluation.

5.10.1 The specimen shall be mounted on the viewing board with the warp or wale in the vertical direction. To facilitate comparative rating, the durable press replicas shall be placed on each side of the specimen as shown in Figure 5214C.

5.10.2 The observer shall stand directly in front of the specimen, 4 feet (1.2 m) away from the viewing board.

5.10.3 The appearance of the specimen shall be compared with the replicas and given the numerical rating of the replica which most nearly matches the appearance of the specimen. The ratings shall be as follows:

- 5 - Appearance equivalent to the DP-5 Replica
- 4 - Appearance equivalent to the DP-4 Replica
- 3.5 - Appearance equivalent to the DP-3.5 Replica
- 3 - Appearance equivalent to the DP-3 Replica
- 2 - Appearance equivalent to the DP-2 Replica
- 1 - Appearance equivalent to or inferior to the DP-1 Replica

Replica 5 represents the smoothest appearance, whereas replica 1 represents the poorest appearance.

5.10.4 Three trained observers shall rate each specimen independently. The average of the three ratings shall be taken as the numerical rating of the specimen.

METHOD 5214

5.10.5 When a specimen from the standard sample was also tested, it shall be rated as described in 5.10.1, 5.10.2, 5.10.3 and 5.10.4.

6. REPORT

6.1 The numerical rating of the sample unit shall be the average of the specimens tested and shall be reported to the nearest 0.1 of a rating.

6.1.1 The individual values used to calculate the average shall also be reported.

6.2 When a standard sample was tested, the numerical rating of the standard sample shall be reported to the nearest 0.1 of a rating.

6.3 Unless otherwise specified, the wrinkle recovery of the sample unit shall be reported as "pass" or "fail" based on the following criteria.

6.3.1 Standard sample.

Pass: The average numerical rating of the sample unit is equal to or higher than that of the standard sample.

Fail: The average numerical rating of the sample unit is less than that of the standard sample.

6.3.2 No standard sample.

Pass: The average numerical rating of the sample unit is equal to or higher than the specified limit.

Fail: The average numerical rating of the sample unit is less than the specified limit.

7. NOTES

7.1 The AATCC wrinkle tester described in this method and the AATCC 3-Dimensional Durable Press Replicas may be obtained from:

AATCC
P.O. BOX 12215
Research Triangle Park, NC 27709

7.2 If the top flange does not weigh 1.1 pound (0.5 kg), sufficient weights in addition to the weight specified in the method shall be added so that the total weight of the specimen is 8.8 pounds (4 kg).

FED. TEST METHODS STD. NO. 191A

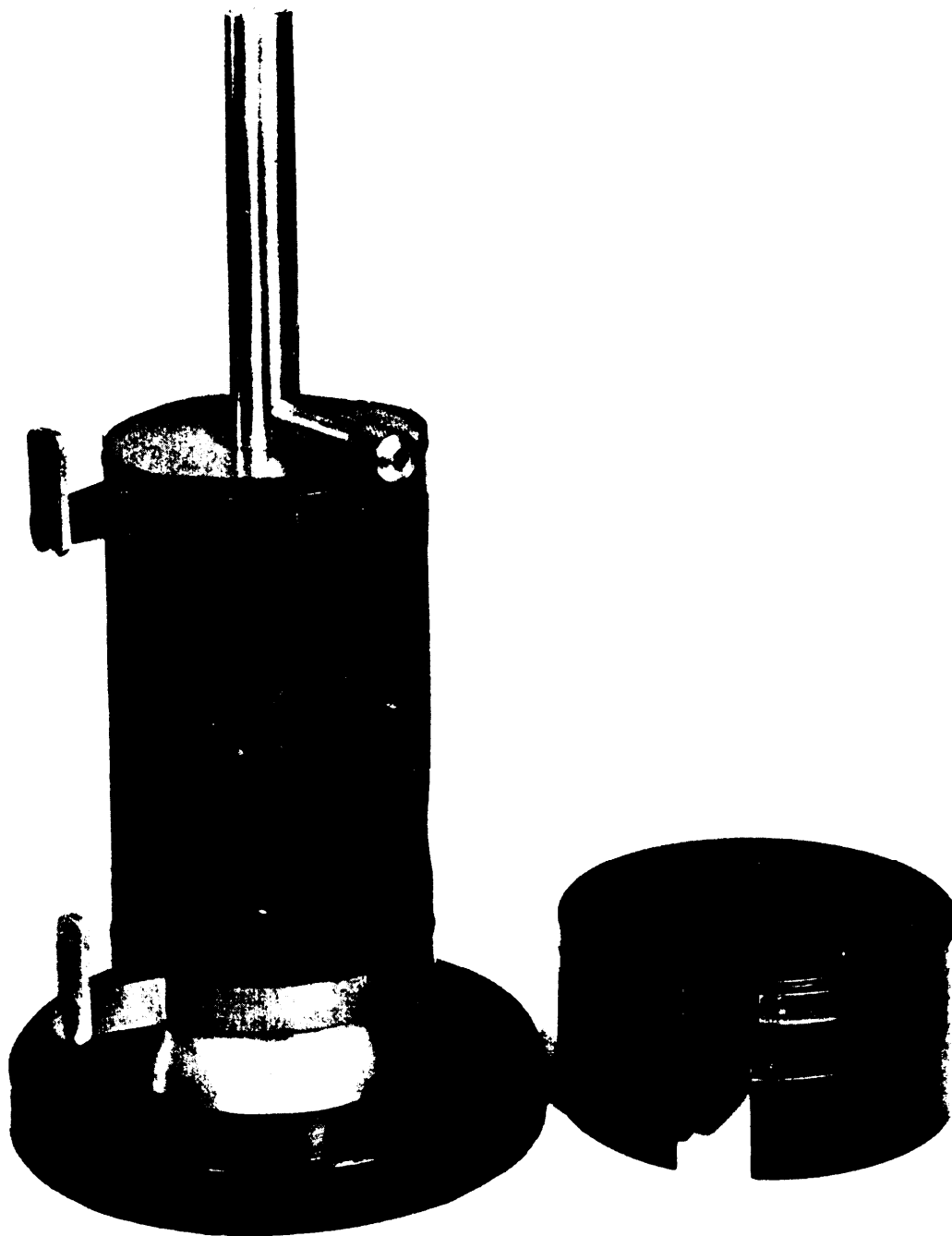

FIGURE 5214A - AATCC Wrinkle Tester

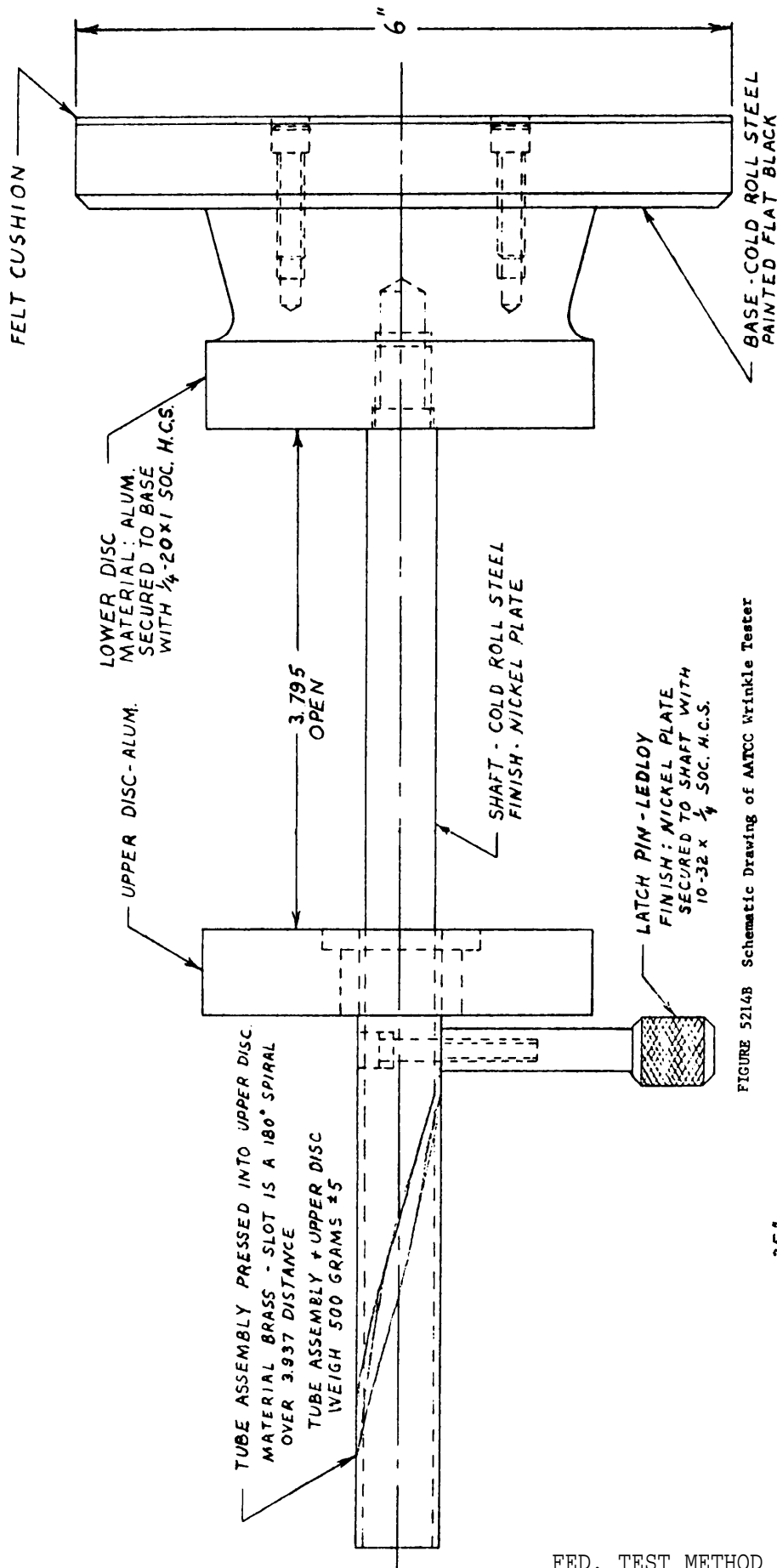

FIGURE 5214B Schematic Drawing of AATCC Wrinkle Tester

OVERALL HEIGHT 12 25/32"

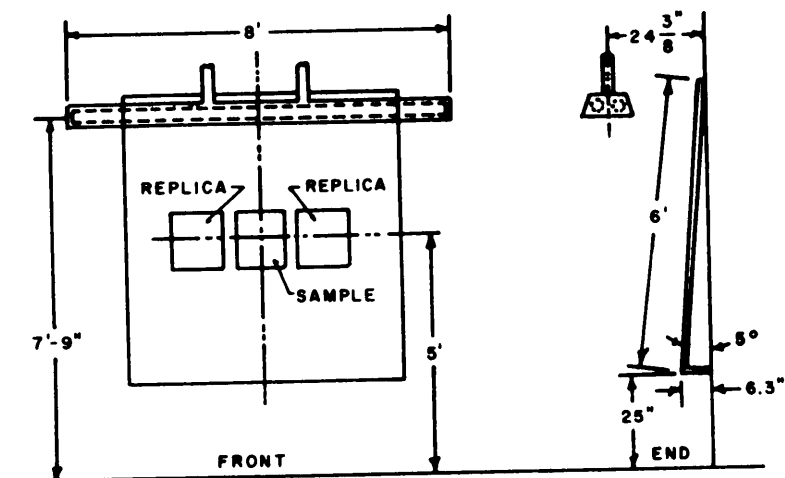

FIGURE 5214C - Lighting equipment for viewing test specimens

METHOD 5216
July 20, 1978

DURABLE PRESS ON FABRICS, SHIRTS AND TROUSERS;
EVALUATION OF: CLOTH APPEARANCE, SEAM APPEARANCE,
FLY APPEARANCE, CREASE APPEARANCE AND SOIL RELEASE

1. SCOPE

1.1 This method is intended for evaluating the cloth, seam, fly (applicable to trousers) and crease appearance and soil release criteria in fabric, shirts and trousers after laundering.

2. TEST SPECIMEN

2.1 Unless otherwise specified in the procurement document, the specimens in the sample unit shall consist of a 4 pound (1.8 kg) load comprised of fabric, shirts, trousers (as applicable) and ballast pieces. Fabric specimens shall consist of three 15 inch by 15 inch (381 mm by 381 mm) samples pressed and cured (as applicable) with a warpwise crease through the center of the specimens.

3. NUMBER OF DETERMINATIONS

3.1 Unless otherwise specified in the procurement document, all fabric, shirts or trousers (as applicable) that make up the 4 pound (1.8 kg) load shall be rated.

4. APPARATUS

4.1 Laundering apparatus.

4.1.1 Automatic washing machine (see 7.1).

4.1.2 Automatic tumble dryer (see 7.1).

4.1.3 Detergent. AATCC standard detergent 124 or equivalent (see 7.2).

4.1.4 Mineral oil (see 7.3).

4.1.5 Blotting paper. Standard blotting paper (see 7.4).

FED. TEST METHOD STD. NO. 191A

METHOD 5216

4.1.6 Weight. 5 pound (2.3 kg) weight, 2-1/2 inches (64 mm) in diameter.

4.1.7 Polyethylene film. 3 by 3 inches (76 by 76 mm) piece of polyethylene film.

4.1.8 Eye dropper. Straight dropper with 0.2 ml capacity per 5 drops.

4.1.9 Ballast pieces. 3 by 3 feet (914 by 914 mm) hemmed pieces of type 128 cotton or polyester/cotton sheeting to be added to applicable test specimens, to make a 4 pound (1.8 kg) load.

4.2 Evaluation area and apparatus for viewing and evaluation of test specimens.

4.2.1 Evaluation shall be conducted in a room where the only source of light will be that specified in 4.2.2. To prevent unwanted reflection of light that will interfere with the observation, the walls of the room may be painted a flat non-reflective black, or blackout curtains may be hung on each side of the viewing areas.

4.2.2 Overhead lighting equipment (see Figure 5216A).

4.2.2.1 Lighting equipment shall consist of the following:

4.2.2.1.1 Two 8-foot type F96 (Cool white) Preheat Rapid Start Fluorescent lamps (without baffle or glass).

4.2.2.1.2 One white enamel reflector (without baffle or glass).

4.2.3 One swatch mount.

4.2.4 Mounting board having outside dimensions of 6 feet by 4 feet (1.8 m by 1.2 m) and painted gray to match No. 2 rating on International Gray Scale for Staining.

4.2.5 A non-reflecting black topped table 35 ± 1 inches (889 ± 25 mm) high. The table shall be at least 30 by 24 inches (762 by 610 mm) with the long dimension parallel and adjacent to the viewing board.

4.2.6 AATCC three dimensional Durable Press Replicas (see 7.5).

4.2.7 AATCC photographic standards for evaluating single and double needle stitching (see 7.5).

4.2.8 AATCC photograph standards for evaluating creases (see 7.5).

METHOD 5216

4.2.9 Deering Milliken photographic standards for evaluating stain or soil release (see 7.5).

4.2.10 NARADCOM photographic standards for trouser flys (see 7.6).

5. PROCEDURE

5.1 Laundering of specimens. A 4 pound (1.8 kg) load comprised of fabric, shirts or trousers (as applicable) and, when necessary, ballast pieces, shall be placed in the washer. Unless otherwise specified, the washer shall be set at the high water level, and a 10 minute wash on the wash and wear or permanent press cycle. The water used shall have a hardness not greater than 50 parts per million (PPM), and the wash water shall be at a temperature of $115^{\circ} \pm 5^{\circ}\text{F}$ ($46^{\circ} \pm 3^{\circ}\text{C}$) with a cold rinse. When the washer has filled, add 140 grams of detergent. Allow the washer to proceed automatically through the final spin cycle. Remove the fabric, shirts or trousers (as applicable) immediately at the completion of the final spin and separate the test specimens and ballast pieces, when required, if tangled. Place the complete washed load in the dryer and dry at the normal cycle and at a setting which generates an exhaust temperature range of 140° to 160°F (60 to 71°C). Operate the dryer until the load is dry and continue tumbling 10 minutes with the heat turned off (cool-down cycle). Remove the load immediately after the machine stops. Repeat the wash and dry cycle until the load has completed the required number of cycles. At the completion of the next to the last cycle, the test specimens shall be stained with mineral oil in 3 different spots. For fabric, the spots shall be placed in the center of the sample: for shirts, the spots shall be placed on the tail; and for trousers they shall be placed on the inside of one leg. Place the area to be stained on blotting paper specified in 4.1.5. Using an eyedropper, place 5 drops of mineral oil for each spot. Place a piece of polyethylene film over the oil, then place a 5 pound (2.3 kg) weight on the film directly over the oil. Keep the weight in place for 60 seconds. Remove the weight and the polyethylene film, and wipe off the excess oil with clean tissue. Allow the test specimens to stand undisturbed for at least 15 minutes, but not longer than 2 hours. Return the stained test specimens and ballast pieces, when required, to the washing machine and wash for the last complete washing and drying cycle. During conditioning and during interruption of the wash and dry cycles the test specimens shall be hung on a garment rack as follows:

Fabrics shall be folded at the crease, and shirts shall be placed on hangers with all buttons fastened. Trousers shall be buttoned or the slide fastener closed, and the legs shall be folded along the crease, and suspended by the leg bottoms in a pants holder or similar device.

5.2 Evaluation. Three trained observers shall evaluate each fabric, shirt or pair of trousers in the sample unit for appearance criteria independent of each other.

METHOD 5216

Fabric. Fabric samples shall be mounted on the viewing board 5 feet (1.5 m) from the floor with the crease in a vertical position. The crease shall be rated in the open position.

Shirts. The shirt shall be placed on a clothes hanger with all buttons fastened and mounted on the viewing board with the center of the garment approximately 5 feet (1.5 m) from the floor and in such a manner that it lies flat on the board.

Trousers. The trousers shall be buttoned or the slide fastener closed and placed on a clothes hanger, similar to that used to hang women's skirts, by spring clips at the waistband. The trousers shall hang with the waistband extended so that the front lays against the back and leg creases fall in the center of the leg as they face the observer. The trousers shall be suspended on the viewing board in such a manner that the trousers lay flat on the surface with the point midway between the top of the waistband and the lower hem of the leg 5 feet (1.5 m) from the floor.

For proper evaluation, the observers shall stand in front of the viewing board at a distance of 4 feet (1.2 m).

5.2.1 Evaluation of cloth appearance. The overhead lighting equipment specified in 4.2.2, and the cloth appearance standards specified in 4.2.6 shall be used. To facilitate comparative testing, the three dimensional plastic replicas that most nearly match the cloth appearance of the fabric, shirt or trousers shall be mounted on the board on each side of the fabric, shirt or trousers. The cloth appearance of the fabric or garment being observed shall be compared with the standards. The overall cloth appearance of the shirt or trousers, front and back combined, shall be rated and assigned the numerical value of the replica that most nearly matches the appearance of the specimen.

The ratings shall be as follows:

- 5 - Appearance equivalent to the DP-5 Replica
- 4 - Appearance equivalent to the DP-4 Replica
- 3.5 - Appearance equivalent to the DP-3.5 Replica
- 3 - Appearance equivalent to the DP-3 Replica
- 2 - Appearance equivalent to the DP-2 Replica
- 1 - Appearance equivalent to or inferior to the DP-1 Replica

Standard 5 represents the best level of appearance while Standard 1 represents the poorest level of appearance.

5.2.2 Evaluation of seam appearance. The overhead lighting equipment specified in 4.2.2 and the photographic standards for evaluating single or double needle stitching, as applicable, specified in 4.2.7 shall be used.

METHOD 5216

To facilitate comparative testing, the seam standard shall be mounted on the viewing board on the right side of the shirt or trousers, as applicable. As seen by the observer the seam standard will be on the left side of the shirt or trousers, as applicable. Seams specified in the procurement document shall be observed and compared with the standard. The appearance of each seam specified in the procurement document shall be assigned the numerical value of the standard that most nearly matches the seam in the specimen.

The ratings shall be as follows:

- 5 - Seam appearance equivalent to Standard 5
- 4 - Seam appearance equivalent to Standard 4
- 3 - Seam appearance equivalent to Standard 3
- 2 - Seam appearance equivalent to Standard 2
- 1 - Seam appearance equivalent to Standard 1

Standard 5 represents the best level of appearance while Standard 1 represents the poorest level of appearance.

5.2.3 Evaluation of fly-appearance (applicable to trousers only). The overhead lighting equipment specified in 4.2.2, and the NARADCOM fly appearance standards specified in 4.2.10 shall be used. To facilitate comparative testing, the fly standard shall be mounted on the viewing board on the right side of the trousers. As seen by the observer the fly standard will be on the left side of the trousers. The fly appearance as specified in the procurement document shall be observed and compared with the standard. The appearance of each fly shall be assigned the numerical value of the standard that most nearly matches it.

The ratings shall be as follows:

- 5 - Fly appearance equivalent to Standard 5
- 4 - Fly appearance equivalent to Standard 4
- 3 - Fly appearance equivalent to Standard 3
- 2 - Fly appearance equivalent to Standard 2
- 1 - Fly appearance equivalent to Standard 1

Standard 5 represents the best level of appearance while Standard 1 represents the poorest level of appearance.

5.2.4 Evaluation of crease appearance. The overhead lighting equipment specified in 4.2.2, and the crease appearance standards specified in 4.2.8 shall be used. The fabric or garment being observed shall then be evaluated for pressed in creases to facilitate comparative testing, the crease appearance standard shall be mounted on the viewing board to the right center of the fabric, shirt or trousers, as applicable. As seen by the observer the crease appearance standard will be on the left side of the fabric, shirt or trousers, as applicable. The applicable fabric or garment shall be adjusted as necessary in order that each crease area being evaluated lies in a relaxed vertical position to allow for proper comparison to the

METHOD 5216

standard. Each crease area specified in the procurement document shall be compared with the standard and assigned the numerical value of the standard that most nearly matches it. Each garment crease area specified in the procurement document shall be rated on an overall appearance basis and assigned a value accordingly, i.e., creases on the back shall be rated in accordance with the overall appearance of all other creases as a unit and not on an individual crease basis.

5.2.4.1 The appearance of the creases on the sample unit (fabric, shirt or trousers) shall be compared with the numerical ratings specified in the Photographic Standard for crease retention.

The ratings shall be as follows:

- 5 - Crease appearance equivalent to Standard 5
- 4 - Crease appearance equivalent to Standard 4
- 3 - Crease appearance equivalent to Standard 3
- 2 - Crease appearance equivalent to Standard 2
- 1 - Crease appearance equivalent to Standard 1

Standard 5 represents the best level of appearance of crease retention, while Standard 1 represents the poorest appearance.

5.2.5 Evaluation of soil release. The overhead lighting equipment specified in 4.2.2 and the soil release standards specified in 4.2.9 shall be used. To facilitate comparative testing, the soil release standard shall be mounted on the viewing board with the center of the standard 45 inches (1.14 m) from the floor. The fabric, shirt or trousers, as applicable, with the stained area visible, shall be placed upon the black topped table and in front of the standard.

5.2.5.1 The stains on the sample unit shall be compared with the soil release standard specified in 4.2.8, and shall be assigned the numerical value of the standard that they most nearly match.

The ratings shall be as follows:

- 5 - Stain or soil equivalent to Standard Stain 5
- 4 - Stain or soil equivalent to Standard Stain 4
- 3 - Stain or soil equivalent to Standard Stain 3
- 2 - Stain or soil equivalent to Standard Stain 2
- 1 - Stain or soil equivalent to Standard Stain 1

Standard 5 represents the best stain removal, and Standard 1 the poorest stain removal.

6. REPORT

6.1 No estimation of ratings falling between standards is allowed and the full numerical rating of the nearest rating must be assigned.

6.2 Cloth, seam, fly (applicable to trousers) and crease appearance ratings. The individual rating values assigned by each of the three observers for each applicable characteristic on the sample unit (fabric, shirt or pair of trousers) shall also be reported.

6.3 Soil release rating. One rating shall be assigned for all three stains by each observer. The rating values assigned by each of the three observers for each sample unit (fabric, shirt or pair of trousers) shall also be reported.

6.4 If the test specimen does not meet the minimum requirements specified in the procurement document for that characteristic tested for, it shall be classified as "failing".

7. NOTES

7.1 Recommended apparatus as specified in 4.1.1 and 4.1.2 is as follows:

For 4.1.1: Kenmore Automatic Washing Machine Model 600 available from Sears, Roebuck and Company or similar washer.

For 4.1.2: Kenmore Automatic Dryer Model 600 available from Sears, Roebuck and Company or similar dryer.

7.2 The AATCC standard detergent 124 is available from:

AATCC Technical Center, P.O. Box 12215, Research Triangle Park, NC 27709.

7.3 An approved mineral oil is "Nujol" available from:

Plough Inc., Memphis, TN

7.4 The blotting paper is available from:

James River Paper Company
P.O. BOX 2218
Richmond, VA 23217

7.5 Replicas and Standards referenced in 4.2.6, 4.2.7, 4.2.8 and 4.2.9 are available from:

The American Association of Textile Chemists and Colorists, P.O. Box 12215, Research Triangle Park, NC 27709.

7.6 The NARADCOM photographic Standards for trouser flies are available from:

Defense Personnel Support Center
ATTN: DPSC-TTC
2800 South 20th Street
Philadelphia, PA 19101

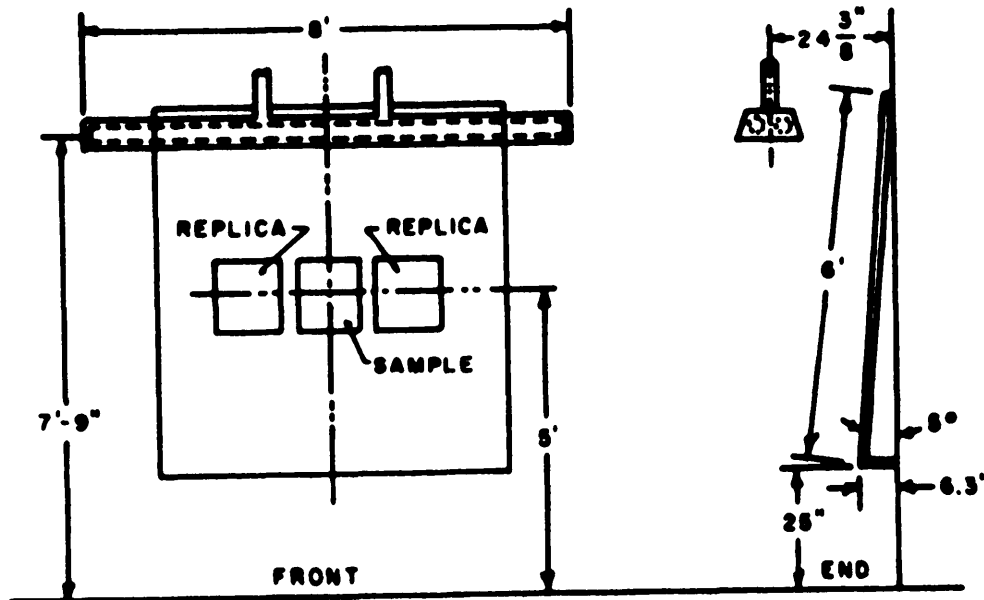

FIGURE 5216A - Overhead lighting equipment for viewing test specimens.

FLEXIBILITY OF CLOTH AFTER LEACHING

1. SCOPE

1.1 This method is intended for determining the change in flexibility of cloth after leaching. It is applicable to untreated, treated, or coated fabrics.

2. TEST SPECIMEN

2.1 The specimen shall have the dimensions required for the specified stiffness evaluation test.

3. NUMBER OF DETERMINATIONS

3.1 Unless otherwise specified in the procurement document, the number of specimens tested from each sample unit shall be as required in the method of test used for determining flexibility.

4. APPARATUS AND METHODS CITED

4.1 Apparatus.

4.1.1 Water container. A water container or tank of such a shape and size that the specimen can be submerged therein with all surfaces of the specimen having free access to the water, and a ratio of the specimen to water shall be not less than 1 to 100 by weight.

4.1.2 Means of supplying a continuous flow of water to the bottom of the container at a temperature of 80° to 85°F (27° to 29°C) and at a rate of about 1,000 ml per minute. Means shall also be provided at the container top for disposing of the overflow.

4.1.3 Means of suspending the specimens in such a reamer that they do not contact the container or each other during leaching.

4.1.4 Means for completely submerging the specimen.

4.1.5 Blotting paper. The blotting paper dimensions shall be 10 inches (254 mm) square (see 7.1).

METHOD 5220

4.2 Methods Cited -

Method 5200, Stiffness of Cloth, Directional; Hanging Heart Loop Method.

Method 5202, Stiffness of Cloth, Directional; Cantilever Bending Method.

Method 5204, Stiffness of Cloth, Directional; Self-Weighted Cantilever Method.

5. PROCEDURE

5.1 The flexibility of the specimen shall be determined as described in Methods 5200, 5202, or 5204, as specified in the procurement document.

5.2 Unless otherwise specified in the procurement document, the specimen shall be submerged in the immersion tank containing water at a temperature of 80° to 85°F (27° to 29°C) and allowed to remain immersed for a period of 24 hours.

5.3 At the end of the leaching period the specimen shall be mangled flat between blotters, air-dried under standard atmospheric conditions, and the flexibility again determined by the same method as used for determining flexibility before leaching.

5.4 Care shall be taken in mounting the specimen for the initial and after leaching flexibility tests that the specimen is positioned exactly the same in regard to the bending direction (inside or outside, warp or filling) of the fabric. When necessary for identification, one side of the specimen shall be marked.

5.5 Calculation of results.

5.5.1 The change in flexibility shall be calculated as follows:

$$\text{Change in flexibility, percent} = \frac{O-E}{O} \times 100 \text{ or } \frac{E-O}{O} \times 100$$

Where:

O = Value before leaching.

E = Value after leaching.

6. REPORT

6.1 Change in flexibility of the sample unit shall be the average of the results obtained from the specimens tested and shall be reported to the nearest 1.0 percent.

6.2 Each individual value used to calculate the average shall also be reported.

7. NOTES

7.1 Blotting paper may be obtained from the following:

Rochester Paper Co.
P. O. Box 185
Rochester, MN 48063

Sorg Paper Co.
901 Manchester Avenue
Middletown, OH 45042

Standard Paper Manufacturing Co.
First and Hull Street
Richmond, VA 23212

Hyman Viener & Sons
P. O. BOX 36
Woodbine, MD 21797

FLEXING RESISTANCE OF COATED CLOTH

1. SCOPE

1.1 This method is intended for determining the resistance of coated cloth to flexing. The effects of the flexing are measured by the change in water resistance of the cloth when subjected to hydrostatic pressure. The method is recommended for testing coated cloth weighing up to 35 ounces per square yard (1186 g/m²).

2. TEST SPECIMEN

2.1 The specimen shall be a square of coated cloth 7 by 7 inches (178 by 178 mm) formed into a cylinder 7 inches (178 mm) long and 2 inches (51 mm) in diameter with approximately 5/8 inch (16 mm) overlap as shown in Figure 5230. The height of the cylinder shall be formed to correspond with the direction of the cloth to be tested.

3. NUMBER OF DETERMINATIONS

3.1 Unless otherwise specified in the procurement document, two specimens of the sample unit shall be tested from each direction of the cloth.

4. APPARATUS AND METHOD CITED

4.1 Apparatus.

4.1.1 Flexing machine. A flexing machine with one or more pairs of cylindrical specimen mounts having the dimensions and relative positions shown in Figure 5230; ring clamps for holding the ends of the specimen in the mounts; motor drive for changing the relative positions of the mounts from 5 inches (127 mm) apart to 1/2 inch (13 mm) apart and back repeatedly at a rate of 150 to 175 cycles per minute.

4.1.2 The machine should be provided with a clutch to permit the motor and speed reduction gear to run continuously while the specimens are being conditioned, especially for low temperature testing when lubricants may solidify.

4.2 Facilities for maintaining the air around the specimen at the required temperature for conditioning and testing.

METHOD 5230

4.3 Method cited.

Method 5512, Water Resistance of Coated Cloth; High Range,
Hydrostatic Pressure Method.

5. PROCEDURE

5.1 The water resistance of the coated cloth specimens undergoing test shall be measured as described in Method 5512. The surface of coated cloth to be exposed to the water shall be as specified in the procurement document.

5.2 Unless otherwise specified in the procurement document, the specimens, from 2.1 (other than specimens tested in 5.1), shall be subjected to 1500 flexes.

5.3 Unless otherwise specified in the procurement document, the specimen shall be conditioned and flexed at a temperature of $73^{\circ} \pm 2^{\circ}\text{F}$ ($23^{\circ} \pm 1^{\circ}\text{C}$).

5.4 The surface of the coated cloth to be on the outside of the cylinder during the flexing test shall be as specified in the procurement document.

5.5 The cylindrical specimen shall be mounted on the machine by means of the cylindrical specimen mounts and ring clamps and placed in the required test atmosphere for a period of one hour before testing. At the end of the conditioning period, the machine shall be started and the specimen flexed the required number of flexes.

5.6 The specimen, after being subjected to the required number of flexes, shall be examined visually for the presence of breaks or cracks in the coating of the cloth.

5.7 The specimen shall then be removed from the machine and the hydrostatic resistance shall be determined as required in 5.1 except that a reading shall be made on each of two alternating quadrants of the flexed specimen. All of the values obtained on the flexed specimens shall be averaged to obtain the water resistance of the cloth (see para. 3.1 and 5.8).

5.8 Calculation. The loss in water resistance of the sample unit shall be calculated as follows:

$$\text{Loss in water resistance, percent} = \frac{W - F}{W} \times 100$$

Where: W = Initial water resistance of unflexed cloth (see 5.1).
F = Water resistance of cloth after flexing (see 5.7).

METHOD 5230

6. REPORT

6.1 Any breaks or cracks (see 5.6) shall be recorded for each specimen tested.

6.2 The flex resistance of the sample unit shall be the loss in water resistance due to flexing and shall be reported to the nearest 1.0 percent.

6.3 Each individual value used to calculate the average shall also be reported.

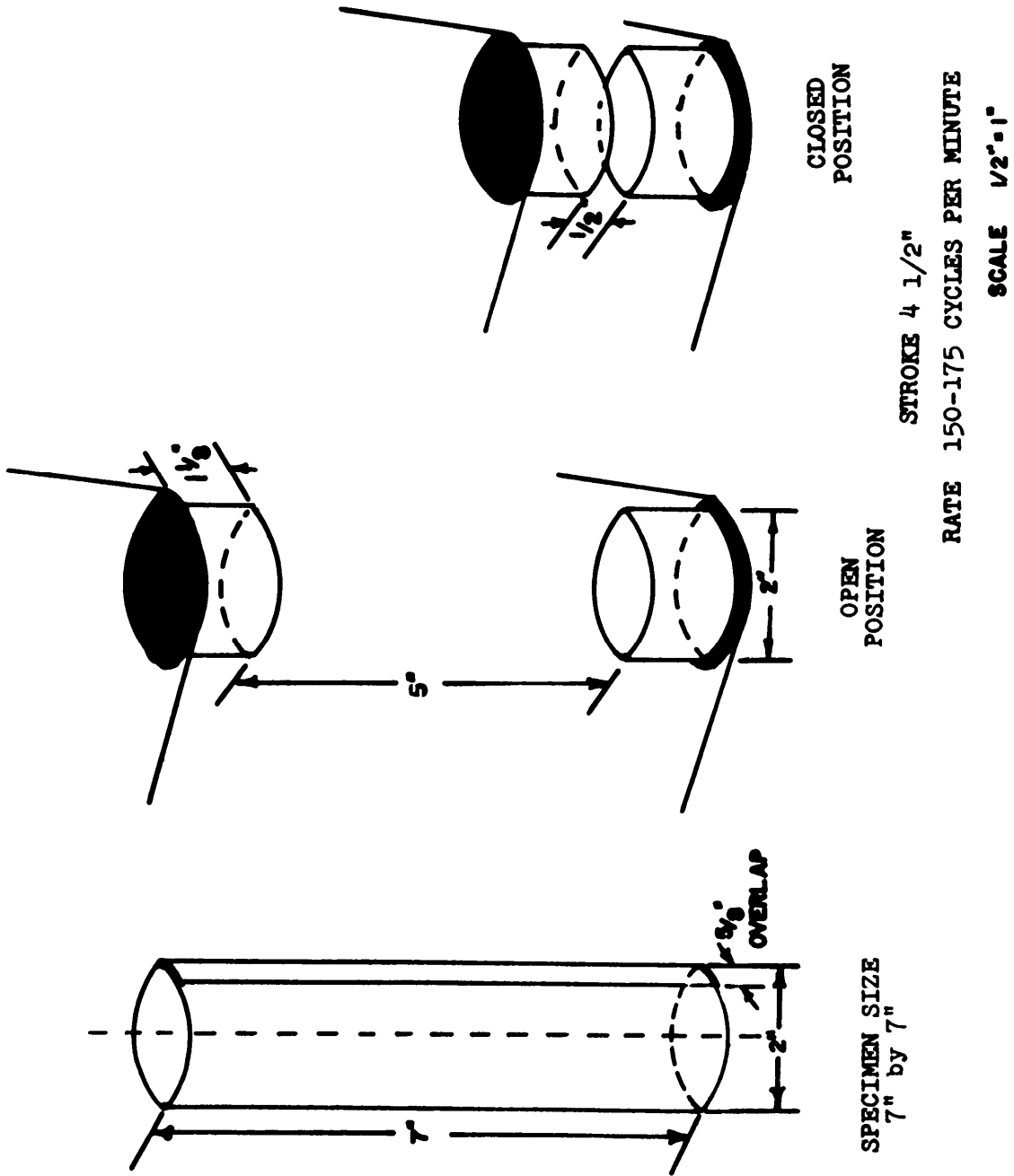

FIGURE 5230 Cylindrical specimen.

ABRASION RESISTANCE OF CLOTH; FLEXING, FOLDING BAR (STOLL) METHOD

1. SCOPE

1.1 This method is intended for determining the resistance of woven fabrics to flexing and abrasion when the specimen is subjected to unidirectional reciprocal folding and rubbing over a given bar under controlled conditions of pressure and tension.

2. TEST SPECIMEN

2.1 The specimen shall be as described in Method 5104 except that the specimen shall be 8 inches to 10 inches (203 mm to 254 mm) in length.

3. NUMBER OF DETERMINATIONS

3.1 Unless otherwise specified in the procurement document, five specimens from each of the warp and filling directions shall be tested from each sample unit.

4. APPARATUS AND METHOD CITED

4.1 Apparatus. (See figure 5300)

4.1.1 Plate assembly consisting of two plane, parallel, smooth plates, one of which makes a reciprocating motion of 125 ± 5 double strokes per minute of 1 inch (25 mm) stroke length. The other plate shall be rigidly supported by a double-lever assembly so as to provide free movement in a direction perpendicular to the plane of the reciprocating plate. It shall be stationary during the test and be well-balanced so that a vertical pressure of from 0 to 10 pounds (0 to 5 kg) can be maintained by means of dead weights.

4.1.1.1 The plates shall be equipped with clamps or jaws to permit the folded specimen to be aligned with its long dimensions parallel to the axis of the reciprocal motion and the fold to be positioned at the center line of the plates perpendicular to the axis of motion. They shall have gripping surfaces to prevent slipping of the specimen during test.

4.1.2 A bar or blade as described below shall be provided. Before a new bar or blade is used for testing, it shall be placed in the tester and subjected to at least 20,000 cycles of abrasion by a 2-1/2 inch (64 mm) fabric strip under a tension of 5 pounds (2.27 kg) (a plied-yarn, grey, cotton duck, weighing from 12 to 15 ounces per square yard (407 to 509 g/m²) is a suitable fabric for this purpose). It shall then be calibrated by use of a standard fabric of high uniformity.

METHOD 5300

4.1.2.1 The folding bar shall be $1/16 \pm 1/64$ inch by $3/8 \pm 1/64$ inch (1.588 ± 0.397 mm by 9.525 ± 0.397 mm) in cross section. It shall be made of tool-steel tipped with an edge of cemented carbide or other highly resistant material. The three sides of the bar, which are in contact with the specimen shall be given a fine finish by grinding and polishing, which will level off the microscopical projections without breaking the edges of the bar.

4.1.2.2 The folding blade shall be made of tool steel 0.01 ± 0.001 inch by 1.0 ± 0.031 inch (0.254 ± 0.0254 mm by 25.4 ± 0.794 mm) in cross-section, having rounded edges and being case hardened and well polished.

4.1.3 A device which will apply a tension to the folded specimen by applying a force from 0 to 7 pounds (0 to 3.17 kg) to the folding bar or blade parallel to the surface of the two plates and perpendicular to the fold of the specimen. The tension must be evenly distributed across the fold of the specimen, and provision shall be made to prevent the bar or blade from tilting.

4.1.4 Revisions shall be made for the automatic stopping of the machine when the specimen is ruptured and for the recording of the number of cycles to reach this end point (see 7.1).

4.2 Method cited.

Method 5104, Strength and Elongation, Breaking of Woven Cloth;
Ravel Strip Method.

5. PROCEDURE

5.1 Unless otherwise specified in the procurement document, the following applicable load shall be applied to the pressure plate and the folding bar or blade:

Weight of Fabric, Ounces Per Square Yard g/m^2)	Flexing Bar or Blade Load, Pounds (kg)	Pressure Plate, Pounds (kg)
Less than 2.5 (84.8)	2 (0.907)	1 (0.453)
2.5 (84.8) but less than 5 (170)	3 (1.361)	1-1/2 (0.680)
5 (170) but has than 7.5 (254 .3)	4 (1.814)	2 (0.907)
7.5 (254.3) but less than 10 (339)	5 (2.268)	2-1/2 (1.134)
10 (339) but less than 15 (509)	6 (2.722)	3 (1.361)
15 (509) and over	7 (3.175)	3-1/2 (1.588)

METHOD 5300

5.2 The end point of the abrasion shall be the number of cycles or state of destruction as specified in the procurement document.

5.3 The specimen shall be folded widthwise and placed symmetrically between the pressure (upper) and the reciprocation (lower) plates of the apparatus. with the specified folding bar or folding blade inserted so that after being clamped and loaded, the tension exerted by the bar or blade is uniformly distributed over the width of the specimen and the long dimension is aligned parallel to the direction of the reciprocal motion. The fold of the specimen shall be at the center of the plates when the reciprocating plate is at midstroke.

5.3.1 When wet abrasion is required by the procurement document, the center portion of the specimen shall be immersed in water at a temperature of $70^{\circ} \pm 2^{\circ}\text{F}$ ($21^{\circ} \pm 1^{\circ}\text{C}$) for at least 10 minutes. After being clamped, and additional one ml of water shall be placed around the fold of the specimen. Additional water must be added during the test if the surplus of water is absorbed by the specimen.

5.4 Pills or matted fiber debris interfering with proper contact between specimen and folding bar or folding blade shall be removed at regular intervals (5 min. or 600 cycles) during the test if they cause a marked vibration of pressure plate.

5.5 When the end point is a specified number of cycles, the specimen shall be subjected to the specified number of cycles of abrasion and evaluated by (a) determining the change in breaking strength or (b) visually for the effect on luster, color, structure, nap, or pilling as specified in the procurement document.

5.5.1 When the change in breaking strength is specified, the breaking strength in each of the warp and filling directions of the original and abraded material shall be determined as described in Method 5104 except that (1) the distance between the jaws of the machine at the start of the test shall be 1 inch (25 mm) and (2) the abraded portion of the specimen shall be placed midway between the jaws of the machine.

5.6 When the end point is the state of destruction, the specimen shall be abraded to rupture and the number of cycles recorded.

5.7 When the specimen slips in the clamps, tension and pressure upon the folded specimen do not remain constant during the test, or an anomalous wear pattern is obtained, such individual measurements shall be disregarded and the determination repeated on an additional specimen.

METHOD 5300

6. REPORT

6.1 When the end point is a specified number of cycles and change in breaking strength is required, the abrasion resistance of the sample unit shall be the average change obtained from the specimens tested in each of the warp and filling directions respectively and shall be reported separately to the nearest 1.0 percent.

6.1.1 The change in breaking strength shall be calculated as follows:

$$\text{Change in breaking strength, percent} = \frac{B - A}{B} \times 100$$

Where: B = Breaking strength before abrasion

A = Breaking strength after abrasion

6.2 When the end point is a specified number of cycles and visual estimation is required, the effect of abrasion on luster, color, structure, napping or pilling, etc. as specified in the procurement document, shall be reported for each specimen.

6.3 When the end point is the state of destruction, the abrasion resistance of the sample unit shall be the average of the number of cycles obtained from the specimens tested in each of the warp and filling directions respectively and shall be reported to the nearest 10 cycles.

6.4 Each individual value used to calculate the average shall also be reported.

7. NOTES

7.1 An abrasion machine of the type described is manufactured by Custom Scientific Instruments, Inc., 13 Wing Drive, Whippany, NJ 07981.

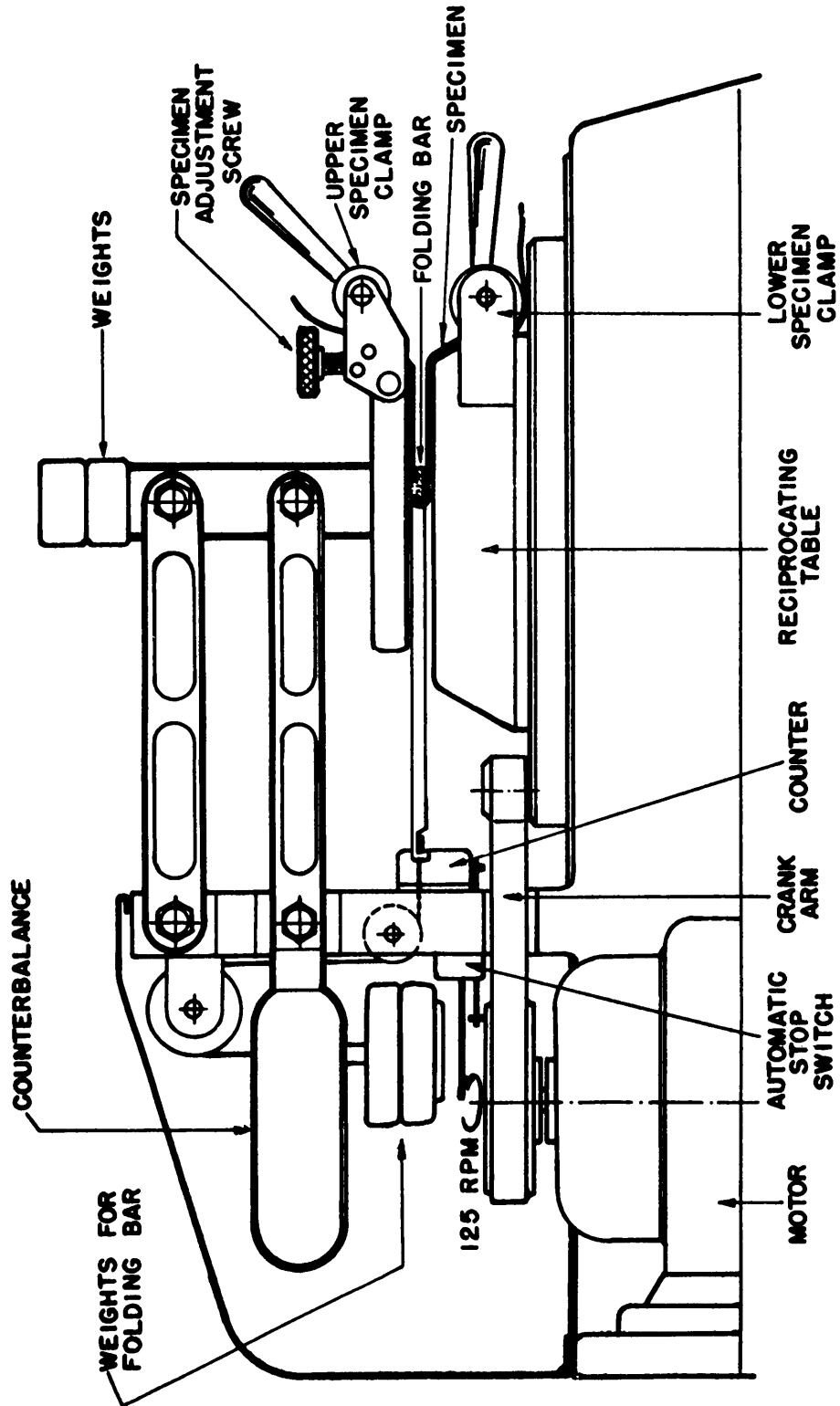

FIGURE 5300 - FLEXING AND ABRASION TESTER

ABRASION RESISTANCE OF CLOTH; INFLATED DIAPHRAGM

(STOLL) METHOD

1. SCOPE

1.1 This method is intended for determining the abrasion resistance of woven and knitted fabrics when the specimen is inflated over a rubber diaphragm under controlled air pressure and subjected to either uni-directional or multidirectional rubbing action.

2. TEST SPECIMEN

2.1 A circle of fabric 4-1/4 inches (108 mm) in diameter. No two specimens shall be taken from areas containing the same warp and filling yarns or the same wales or courses.

3. NUMBER OF DETERMINATIONS

3.1 Unless otherwise specified in the procurement document, five specimens shall be tested from each sample unit.

4. APPARATUS (See figure 5302)

4.1 Circular clamp for mounting specimen. Circular clamp provided with a clamping ring and tightening collar for mounting specimens over a rubber diaphragm. The circular opening of the clamping ring shall be 3.60 inches \pm 0.005 inch (91.4 mm \pm 0.1 mm) in diameter (approximately 10 square inches) (6452 sq. mm) and that of the collar 3.60 inches (91.4 mm) or more.

4.1.1 The height from the surface of the clamped-in specimen to the upper edge of the tightening collar shall not exceed 3/8 inch (10 mm).

4.1.2 The clamping area of the body of the clamp and the ring shall be approximately 4-1/4 inches (108 mm) in diameter, having gripping surfaces to prevent slipping of the specimen and leakage of air pressure during the test.

4.2 Air pressure. Means shall be provided for supplying air pressure to the body of the clamp so that the pressure under the diaphragm can be controlled between 0 and 6 pounds per square inch (0 and 41 kPa) with an accuracy of \pm 0.05 pound per square inch (\pm 0.34 kPa).

4.3 Rubber diaphragm. A rubber diaphragm 4-1/2 inches (114 mm) in diameter, not less than 0.02 and not more than 0.04 inch (0.5 and not more than 1.0 mm) in thickness.

METHOD 5302

4.3.1 When the 10 square-inch (6452 sq. mm) clamped area is inflated by a pressure of 1 pound per square inch (6.9 kPa), the elevation shall be from 0.5 to 1.0 inch (13 to 25 mm).

4.3.2 A metallic contact pin of 1/8-inch (3 mm) in diameter shall be sealed into the center of the diaphragm so that it is flush with the diaphragm surface. Provision shall be made for flexible electrical connection from this contact pin to the ground of the machine.

4.3.3 The strain distribution in the diaphragm must be uniform so that when inflated without the specimen, it assumes the shape of a section of a sphere.

4.4 Driving mechanism. A driving mechanism so designed that the circular clamp makes a reciprocal motion of 125 ± 5 double strokes per minute of 1-inch (25 mm) length. Provisions shall also be made for rotation of the clamp so that one revolution can be completed in not less than 50 and not more than 100 double strokes.

4.5 Abradant-plate assembly. The abradant-plate assembly shall be composed of a specified abradant mounted on a plate rigidly supported by a double-level parallelogram so as to provide for free movement in a direction perpendicular to the plane of the reciprocating specimen clamp. The abradant-plate assembly shall be well-balanced so that a vertical pressure from 0 to 5 pounds (0 to 2.3 kg) can be maintained by means of dead weights.

4.5.1 Provision shall be made for mounting different abradants such as abrasive paper, fabrics, etc., on this plate and to stretch them into an even position.

4.5.2 An electrically insulated contact pin adjustable to the thickness of the abradant shall be mounted into this plate on the length axis at one of the turning points of the center of the clamp.

4.6 Relay for closing low voltage circuit, to stop machine. A relay for closing a low-voltage circuit and stopping the machine when the pin on the lower side of the abradant plate and the pin inserted in the center of the diaphragm come in contact.

4.7 Pressure gauge. Means for indicating the diaphragm pressure, the inflation height of the specimen, and the number of abrasion cycles (1 cycle = 1 double stroke).

5. PROCEDURE

5.1 The abradant shall be as specified in the procurement document.

METHOD 5302

5.2 Unless otherwise specified, an air pressure of 4 pounds per square inch (28 kpa) shall be applied to the diaphragm and a load of 1 pound (0.45 kg) shall be applied to the abradant.

5.3 The direction of abrasion shall be unidirectional or multidirectional as specified in the procurement document.

5.4 The end point of the abrasion shall be the number of cycles or state of destruction as specified in the procurement document.

5.5 The specimen shall be placed over the rubber diaphragm in a smooth condition and shall not be distorted by the clamping. If wet abrasion is specified in the procurement document, the dry clamped-in specimen shall be covered with 10 ml of distilled water at a temperature of $70^{\circ} \pm 2^{\circ}\text{F}$ ($21^{\circ} \pm 1^{\circ}\text{C}$).

5.6 The abradant shall be placed on the abradant plate under just sufficient tension to be held smooth and in such a position that the contact pin, reaching through a hole in the abradant, shall be even with the surface of the abradant.

5.7 When unidirectional abrasion is required, the rotation of the specimen clamp shall be eliminated and the specimen shall be brought into the specified direction by turning and setting the clamp after the specimen has been inflated.

5.8 When multidirectional abrasion is required or if no specific indications to the abrasion direction is given in the procurement document, the rotation mechanism of the specimen clamp shall be engaged.

5.9 Air-pressure control and contact between inflated specimen and loaded abradant shall be in a state of equilibrium before abrasion is started.

5.10 Pills of matted fibers interfering with proper contact between specimen and abradant shall be removed as specified during the test if they cause a marked vibration of the abradant plate.

5.11 When the end point is a specified number of cycles, the specimen shall be abraded the required number of cycles and then evaluated visually for the effect of the abrasion on luster, color, fabric structure, or other characteristics as specified.

5.12 When the end point is the state of destruction, the specimen shall be abraded until all fibers in the center of the abrasion area are worn off and the contact pins in the abradant plate and diaphragm come in contact actuating the electrical relay and stopping the machine.

METHOD 5302

5.13 When the specimen slips in the clamp or the air pressure does not remain constant during the test or an anomalous wear pattern is obtained, such a specimen shall be disregarded and the determination repeated on an additional specimen.

6. REPORT

6.1 When the end point is a specified number of cycles, the abrasion resistance of the sample unit shall be the effect on color, luster, fabric structure, or other characteristics, as specified in the procurement document. The abrasion resistance of each specimen shall be reported.

6.2 When the end point is the state of destruction, the abrasion resistance of the sample unit shall be the average of the number of cycles obtained from the specimens tested and shall be reported to the nearest 10 cycles.

6.3 Each individual value used to calculate the average shall also be reported.

7. NOTES

7.1 An abrasion machine of the type described may be obtained from:

Custom Scientific Instrument, Inc.
13 Wing Drive
Whippany, NJ 07981

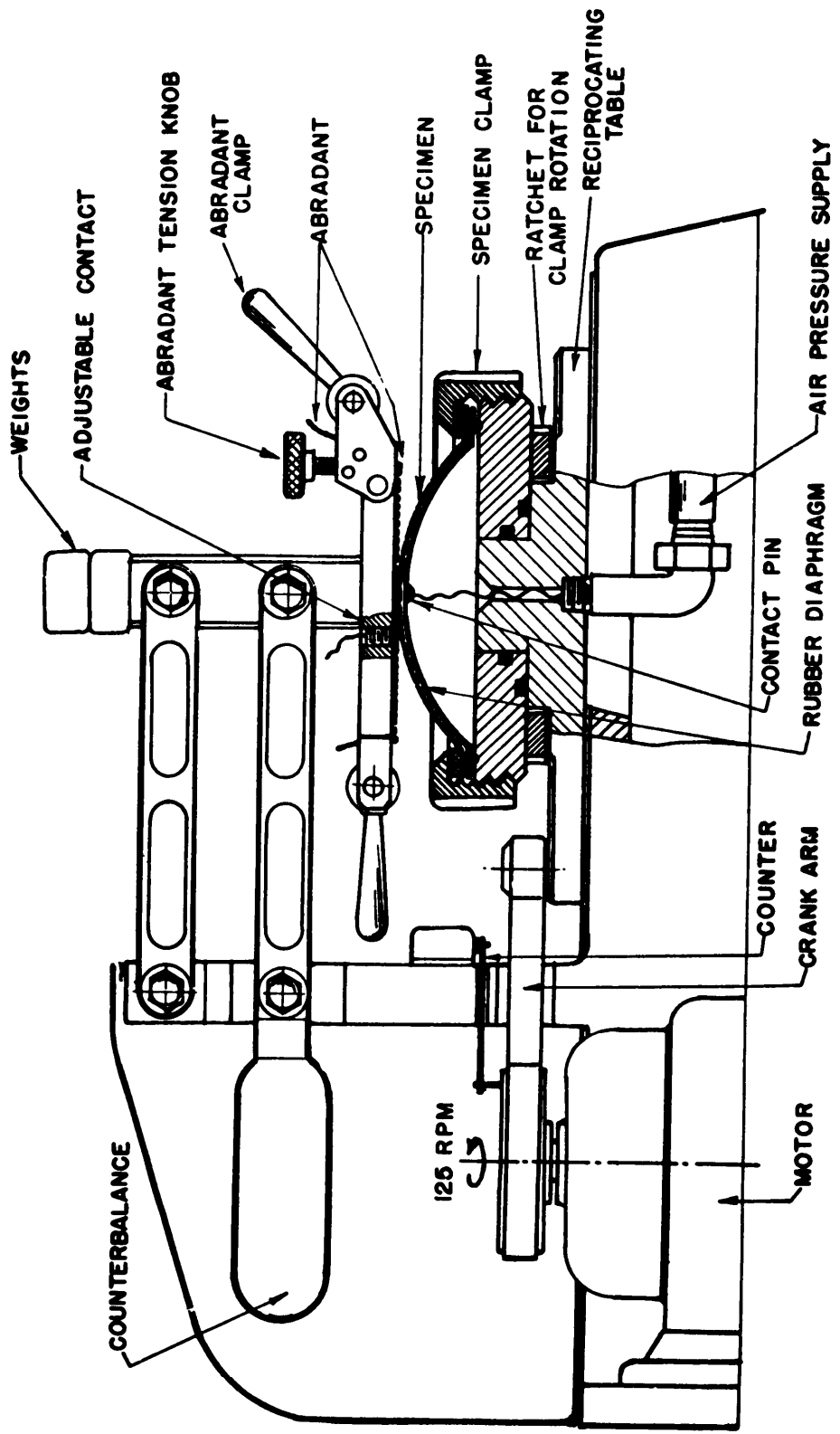

FIGURE 5302 - INFLATED DIAPHRAGM ABRASION TESTER

COLOR CHANGE OF CLOTH DUE TO FLAT ABRASION (FROSTING);
WIRE SCREEN METHOD

1. SCOPE

1.1 This method is intended for evaluating the resistance of colored cloths to change in shade caused by multidirectional flat abrasion. Frosting is a change of cloth color caused by localized abrasive wear. It can be used for all dyed cloths, but is especially sensitive to the color change of durable press cross-dyed blend cloths, in which one fiber is abraded away faster than another. It is also sensitive to the abrasion of constructions in which there is a variation in, or incomplete penetration of dyestuff.

2. TEST SPECIMEN

2.1 The specimen shall be a square piece of cloth 5 inches (127 mm) by 5 inches (127 mm). No two specimens shall contain the same warp and filling yarns. Do not cut specimens nearer the selvage than one tenth the width of the cloth.

3. NUMBER OF DETERMINATIONS

3.1 Unless otherwise specified in the procurement document, three specimens shall be tested from each sample unit.

4. APPARATUS AND METHOD CITED

4.1 Surface abrader. A surface abrader equipped with attachment to produce frosting (see Figure 5303).

4.2 Frosting attachments. Frosting attachments shall consist of:

- a. Rubber "O" ring.
- b. Conical mounting piece.
- c. 16 x 16 mesh, 0.009 ± 0.0003 inch (0.229 ± 0.008 mm) wire, stainless steel screening abradant.
- d. Side clamps.
- e. Circular specimen holder.

4.3 Gray Scale for Color Change.

4.4 Method cited.

Method 9010, Shade Matching of Textile Materials; Visual Method.

METHOD 5303

5. PROCEDURE

5.1 All specimens shall be conditioned in accordance with Section 4 of this Standard and testing shall be conducted in the standard atmosphere for testing textiles.

5.2 Remove the circular surface abrasion head from the reciprocating table of the abrasion tester by removing the circular locking stud in the center. Use the special two-pronged wrench supplied with the specimen holder kit. Insert the circular frosting specimen holder in the surface abrasion head, place the metal O-ring over the specimen holder, and lock it into place with the screw collar (see 7.3).

5.3 Place the specimen face up and center it over the specimen holder, and then place the conical mounting piece over the specimen. Insert the rubber O-ring over the specimen and into the groove. Remove the mounting piece.

5.4 Replace the surface abrasion head holding the test specimen into the reciprocating table. Attach the stainless steel screen (see 7.4) to the abradant plate and clamp the screen ends in the abradant plate clamps. The warp of the abradant "fabric" shall be parallel to the reciprocating motion of the upper head. Apply sufficient tension by means of the front tension clamp to keep the screen flat. Secure the sides with the side clamps.

5.5 Apply head weights of 2.5 pounds (1.13 kg) to the balanced abradant head.

5.6 Adjust the rotary motion pawl so as to rotate the surface abrasion head approximately one revolution per 100 cycles.

5.7 Gently lower the head until it contacts the test specimen.

5.8 Start machine and abrade the specimen for 1200 cycles and stop the machine.

5.9 Remove the abraded specimen from the surface abrasion head.

5.10 Remove any disintegrated or worn away cloth by hand rinsing the test specimen in clear lukewarm water at 100°F (38°C). Blot between towels to remove excess water. Place the specimen face down between two pieces of clean white cotton cloth and press with a hand iron at approximately 300°F (149°C) until the specimen is dry.

5.11 Evaluation.

5.11.1 Evaluate the abraded specimen under artificial daylight or equivalent (see Method 9010).

5.11.2 Classify the color change by comparing the specimen with the Gray Scale for Color Change and record the lowest rating observed for each specimen in accordance with the following scale:

<u>Frosting Rating</u>	<u>Gray Scale</u>
5 - None or Negligible	5.0
4 - Slight	4.5
3 - Noticeable	4.0
2 - Considerable	3.5
1 - Severe	3.0

6. REPORT

6.1 Unless otherwise specified in the procurement document, the average rating for the sample unit shall be reported to the nearest 0.1 scale rating.

6.1.1 Each individual rating for each specimen used to calculate the average shall also be reported.

7. NOTES

7.1 A surface abrader and specimen holder kit satisfactory for performing this test may be obtained from Custom Scientific Instruments, Inc., 13 Wing Drive, Whippany, NJ 07981.

7.2 The Gray Scale for Color Change may be obtained from AATCC, P.O. Box 12215, Research Triangle Park, NC 27709.

7.3 When the specimen holder with the foam rubber cushion is first received or after extensive use, the surface plane of the rubber head may not be in perfect alignment with the abradant plate resulting in a poor or uneven wear pattern. If such is the case, the condition can be rectified by abrading the rubber surface (without specimen) of the tester with "0" emery cloth under 2.5 pounds (1.13 kg) head weight.

7.4 The screen should be washed initially to remove oil. It is recommended that after each test the stainless steel abradant be cleaned of detritus with a compressed air gun with a safety nozzle or a suitable vacuum cleaner. It is also recommended that the screen be washed periodically in a mild detergent to remove possible build-up of matter which cannot be blown off with an air gun or a vacuum cleaner. Worn or defective wire screen abradant should be replaced immediately.

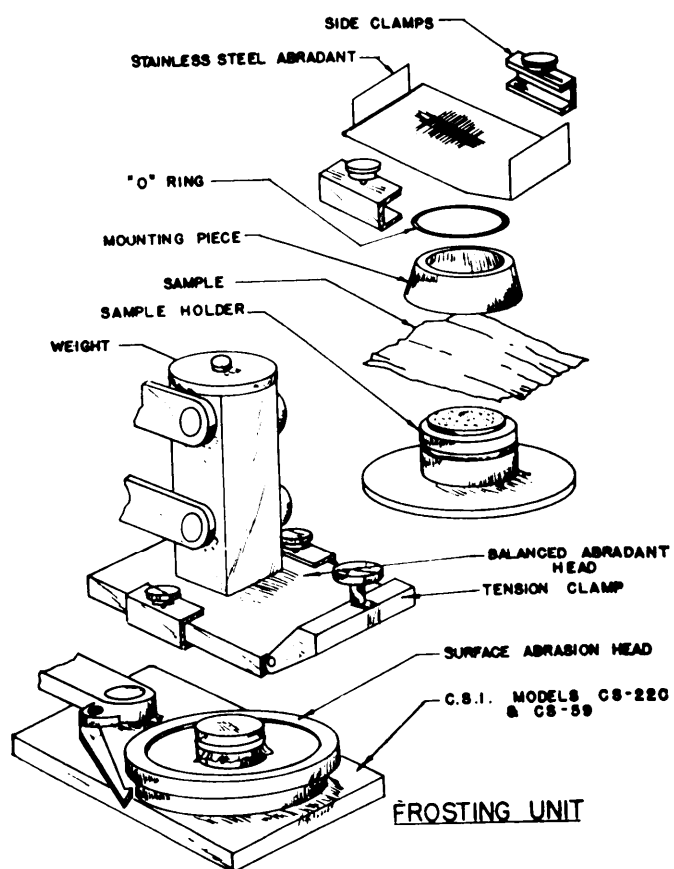

Figure 5303 - Schematic Drawing of Frosting Unit

(Courtesy of AATCC)

ABRASION RESISTANCE OF CLOTH; OSCILLATORY METHOD
(WYZENBEEK) METHOD

1. SCOPE

1.1 This method is intended for determining the abrasion resistance of woven fabrics when subjected to unidirectional rubbing action under controlled conditions of pressure, tension, and abrasive action.

2. TEST SPECIMEN

2.1 A rectangle of cloth 9 by 1-7/8 inches (229 by 48 mm). The long dimension shall be cut parallel to the warp yarns for warpwise abrasion and parallel to the filling yarns for filling-wise abrasion.

3. NUMBER OF DETERMINATIONS

3.1 Unless otherwise specified in the procurement document, 16 specimens from each of the warp and filling directions shall be tested from each sample unit.

4. APPARATUS AND METHOD CITED

4.1 Apparatus.

4.1.1 Oscillatory cylinder. Oscillating cylinder section with edge clamps to permit mounting of a sheet of abrasive material over its curved surface. Three or four specimen-holding arms shall be provided to permit testing of several specimens simultaneously.

4.1.1.1 Each arm shall consist of a set of controlled tension clamps and a controlled pressure pad. Tension on the specimen shall be adjusted by use of a calibrated sliding weight on a bar attached to the forward specimen clamp. The rear clamp shall butt against a thumb screw to provide for taking up the slack of the specimen. The pressure pad, made of sponge rubber, shall be fitted to a pressure bar at the top of the specimen holding arm. A second calibrated sliding weight shall furnish the desired pressure between the pad and the cylinder section.

4.1.1.2 The cylinder section shall have a diameter of 6 inches (152 mm) and the rubber pad, 2 by 2 inches (51 by 51 mm) in dimension, shall be shaped to the curve of the cylinder surface. The section shall oscillate through an arc of 3 inches (76 mm) long at the rate of 90 cycles (double rubs) per minute.

METHOD 5304

4.1.1.3 Suspended over the drum shall be two slotted vacuum pipes which shall serve to remove lint and dust particles.

4.1.2 An automatic counter shall be provided for recording the number of oscillations.

4.1.3 Unless otherwise specified in the procurement document, the abradant shall be No. 0 emery paper.

4.2 Method cited.

Method 5102, Strength and Elongation, Breaking of Woven Cloth;
Cut Strip Method.

5. PROCEDURE

5.1 Unless otherwise specified in the procurement document, the specimen shall be subjected to 250 continuous cycles under a tension of 2 pounds (8.9 N) and under a load of 2 pounds (8.9 N).

5.2 Unless otherwise specified in the procurement document, the abradant shall be changed for each set of specimens.

5.3 Unless otherwise specified in the procurement document, the face surface (weave face, finished side, coated side, etc.) of the specimen shall be subjected to abrasion.

5.4 Unless otherwise specified in the procurement document, the effects of the abrasion shall be measured by determining the change in breaking strength or the residual breaking strength as specified.

5.5 The specimen shall be placed in the clamps of the apparatus with the long dimension parallel to the direction of the abrasion. The specimen shall be drawn just tight enough to bring the weighted tension scale bar into a horizontal position. If the specimen stretches during the test, the scale bar shall be brought back into a horizontal position by adjusting the screw behind the rear clamp. The weight of the pressure bar shall be set at the required load. Depending on the thickness of the specimen being tested, the knurled screw on the top of the overarm shall be so adjusted as to cause the pressure bar to rest in a horizontal position. The specimen shall be abraded under the required tension and load for the required number of cycles.

5.6 When the change in breaking strength due to abrasion is required, the breaking strength of the material before and after abrasion shall be determined as described in Method 5102, except that (1) the width of the specimen shall be as required in 2.1, (2) the strength shall be determined by a single operator on a single tester, and (3) the abraded portion of the specimen after abrasion shall be midway between the jaws of the machine.

5.7 When the residual breaking strength of the abraded material is required, the breaking strength shall be determined as described in Method 5102, with the exceptions listed in 5.6.

6. REPORT

6.1 Unless otherwise specified in the procurement document, the abrasion resistance of the sample unit shall be expressed as a residual breaking strength or change in breaking strength.

6.1.1 The change in breaking strength shall be calculated as follows:

$$\text{Change in breaking strength, percent} = \frac{B - A}{B} \times 100$$

Where: B = breaking strength before abrasion.

A = breaking strength after abrasion.

6.1.2 Change in breaking strength shall be the average of the results obtained from the specimens tested in each of the warp and filling directions respectively and shall be reported separately to the nearest 1.0 percent.

6.2 Residual breaking strength shall be the average of the results obtained from the specimens tested in each of the warp and filling directions and they shall be reported separately to the nearest 1 pound (to the nearest 1 N).

6.3 Each individual value used to calculate the average shall also be reported.

7. NOTES

7.1 An abrasion machine of the type described in this method is manufactured by Wyco Tool Co., 4601 W. Addison, Chicago, IL 60641.

ABRASION RESISTANCE OF CLOTH; ROTARY PLATFORM,
DOUBLE-HEAD (TABER) METHOD

1. SCOPE

1.1 This method is intended for determining the abrasion resistance of cloths in terms of percent change in breaking strength, or breaking strength after a given period of abrasion, or the number of abrasion cycles required to produce a specified state of destruction. It is used to evaluate cloth durability when the specimen is subjected to rotary rubbing action under controlled conditions of pressure and abrasive action.

2. TEST SPECIMEN

2.1 The specimen shall be a 5-inch (127 mm) square or circle of fabric, and not greater than 1/4 inch (6 mm) in thickness. The specimens shall be taken from areas of the fabric not represented by the same warp or filling yarns. A 1/4 inch (6 mm) diameter hole shall be punched in the center of the specimen.

3. NUMBER OF DETERMINATIONS

3.1 Unless otherwise specified in the procurement document, 10 specimens from each of the warp and filling directions shall be tested from each sample unit.

4. APPARATUS AND METHOD CITED

4.1 Apparatus. (Figure 5306)

4.1.1 Rotary platform, double head abraser. An abrasion machine comprising in general of a housing of compact design, a removable flat circular specimen-holder, a pair of pivoted arms to which are attached the abrasive wheels, a motor for rotating the platform and specimen, a fan for cooling the motor, and a counter for indicating the revolutions of the specimen-holder is so mounted as to produce a circular surface travel of an essentially flat specimen in the plane of its surface. The abrasive wheels, which are attached to the free end of the pivoted arms, rotate and have, when resting on the specimen, a peripheral engagement with the surface of the specimen, the direction of travel of the periphery of the wheels and of the specimen at the contacting portions being at acute angles and the angle of travel of one wheel periphery being opposite to that of the other. Motion of the abraser wheels, in opposite directions, is provided by rotation of the specimen and the associated friction therefrom.

4.1.1.1 Specimen holder. The specimen-holder is supported by an adapter which is motor-driven and provides motion for the circular travel of the specimen-holder.

4.1.1.2 Load adjustment weights. A load adjustment for varying the load of the abramer wheels on the specimen. The pivoted abramer arms without auxiliary weights or counterweights apply a load against the specimen of 500 grams (1.1 lbs) per wheel. Addition of weights by the manufacturer increases the load to 1,000 grams (2.2 lbs). A counterweight attachment permits reduction of load against the specimen to 250 grams (0.55 lb) and 125 grams (0.27 lb) per wheel.

4.1.1.3 Clamping rings. Clamping rings for securing the specimen to the specimen-holder, one for use with lighter weight fabrics, and a larger one for use with heavier fabrics.

4.1.1.4 Wheels.

4.1.1.4.1 Types. Abraser wheels of the rubber-base or vitrified-base types. Both types of wheels are manufactured in different grades of abrasive quality 1. The wheels shall be leadbushed, 1/2 inch (13 mm) thick and approximately 2 inches (51 mm) in diameter. The wheels customarily used for testing textiles are the rubber-base resilient type composed of abrasive grains encushioned in rubber. Consequently, they are distorted during operation of the abramer. Accordingly, the wheels are mounted so as to compensate for this distortion and it is important that they be set as prescribed in 4.1.1.5.1.

Vitrified-base wheels are the hard abrasive type. They may be cut with a diamond point to alter the roughness of the wheel, the stroke of cut determining the degree of grit. The position of these wheels is not critical but it is recommended that they be set as prescribed in 4.1.1.5.1.

4.1.1.4.2 Selection for test. Since there exists variation in abrasive quality between and within rubber-base wheels of the same grade, a method shall be followed in the selection of wheels for a particular test that will reduce this variation. All rubber-base wheels shall be tested individually on a selected reference fabric. They shall be grouped in sets of three pairs such that the average abrasiveness of the three falls within a specified tolerance. The wheels shall then be used in sets as established. The specimens of fabric shall be grouped in three sets, the members of the-set being selected at random from the whole area of the sample. Each set shall be abraded with one of the three pairs of wheels, and the report shall be based on the average for the three sets.

In the use of vitrified-base wheels, both wheels of the pair to be used shall be similar in abrasion characteristics. This shall be checked on a selected reference fabric. Once a satisfactory pair is obtained, it may be used for an indefinite period of time without changing its abrasive quality. Experience has shown that a single pair can be used for at least 1 year in constant use without changing in abrasive quality.

4.1.1.4.3 Resurfacing and cleaning. Due to uneven wear and clogging of the surface crevices with fiber particles, sizing, finishing materials, and the like, the abrading wheels shall be resurfaced or cleaned at established intervals during tests, the frequency of which depends on the type of material being tested and the type of wheel used. Rubber-base wheels wear unevenly during use and clog up as abrading progresses, thus requiring resurfacing and cleaning at appropriate intervals. Resurfacing disks (Carborundum-coated paper) of various degrees of coarseness are available for this purpose. These are mounted on the resurfacing platform which replaces the specimen-holder on the center shaft. A stiff brush may be used for removing loose particles from the surface of the wheels. A resurfacing and cleaning schedule shall be adopted for tests on various materials. The specimen shall be abraded for 2 specified number of revolutions of the table, such as 300 (or some other number, depending on the surface being abraded), after which the wheels shall be resurfaced for a specified number of revolutions of the table, such as 30, with the abrasive paper and then brushed clean. The specimen shall again be replaced and the sequence of abrading and resurfacing shall be continued to completion of the test. The resurfacing disks should be used for a definite number of revolutions of the table and discarded. On rubber-base wheels of medium coarseness, it has been found that 6 or 7 resurfacing of 30 revolutions of the table each were the limit of utility of the disks.

Vitrified-base wheels do not wear unevenly and consequently require no resurfacing unless the surface is accidentally chipped or otherwise marred. The crevices of the surface clog during use and, during the test, should be cleaned of loose particles at specified intervals, such as every 300 revolutions of the table. Compressed air has been found to be most suitable for this purpose and is recommended. Vitrified-base wheels are not recommended for use on fabrics with surface coatings which clog the wheels too rapidly and cannot be removed with ease. If such material requires special solvents for removal or necessitates resurfacing of the wheels, such practice would not be recommended and the wheels should not be used.

4.1.1.5 Machine adjustments.

4.1.1.5.1 Wheels. In mounting rubber-base wheels, their position with respect to the center of the specimen-holder is critical. The lateral distance from the left-hand wheel-mounting flange to the center of the specimen-holder shall be 1-1/64 inches (25.8 mm) and from the same point to the right-hand wheel-mounting flange the distance shall be 1-5/64 inches (27.4 mm).

METHOD 5306

The position of vitrified-base abrasive wheels with respect to the center of the specimen-holder shall be equally spaced on both sides 1-3/64 inches (26.6 mm) from the wheel-mounting flange to the center of the specimen-holder.

4.1.1.5.2 Platform. The vertical distance from the center of the pivot point of the abraser arms to the top of the specimen-holder shall be approximately 1 inch (25 mm). This measurement is specified to prevent the possibility of errors incurred by installing a thrust bearing or the like to support the specimen-platform. Such adaptations shall be made so that the platform will remain at the above specified level. The specimen-platform shall rotate in the plane of its surface.

If it fails to do so and exhibits a tendency to wobble, the holder and adapter shall be replaced or a thrust bearing installed to support the specimen-holder.

4.1.1.5.3 Load. In order to reduce the load of the abraser wheels on the specimen, a counterweight attachment is provided. The use of this counterweight is not recommended, since studies in this regard have indicated variability in results due to the unequal counter-weighting of the individual arms.

4.1.1.5.4 Abraser wheel bearings. The abraser wheel bearings, that is, the two pair of bearings installed in the free end of the pivoting arms to support the abraser wheels, should not stick when caused to spin rapidly by a quick driving motion of the forefinger. The degree of freedom of rotation of these bearings, however, is not critical.

4.1.2 A means of removing dust, lint, and any disintegrated or worn away cloth from the test specimen by brushing or by vacuum, shall be specified in the procurement document.

4.1.3 A counter for recording the number of rotations of the specimen-platform.

4.2 Method Cited.

Method 5100, Strength and Elongation, Breaking of Woven Cloth;
Grab Method.

5. PROCEDURE

5.1 Unless otherwise specified in the procurement document, the speed of the specimen-platform shall be 70 revolutions per minute.

5.2 The number and type of abrasive wheel and the magnitude of the counterweights shall be as specified in the procurement document.

5.3 Unless otherwise specified in the procurement document, the face surface of the specimen (weave face, finished side, coated side, etc.), shall be the surface to abrade.

5.4 The end point of the abrasion shall be (1) the number of rotations of the specimen-platform or (2) the state of destruction, as specified in the procurement document.

5.5 The test specimen shall be placed over the rubber mat on the specimen-holder. The ring clamp shall be placed over the specimen with the screw of the clamp at one end of the warp diameter and then pressed halfway down on the specimen-holder, the screw partly tightened, the clamp then pressed down as far as possible, and the screw tightened firmly. The washer and knurled nut shall then be secured in place to hold the center of the specimen.

5.6 The specimen-platform shall be rotated at the required speed and the specimen abraded to the required end point.

5.6.1 The specimen shall be cleaned of lint and abrasive particles on a scheduled basis as with the resurfacing and cleaning of the abramer wheels. The specimen shall not be removed from the specimen-holder until the entire test is completed. The rubber mat shall be wiped clean after each test.

5.7 When the number of rotations is specified as the end point, the abrasion resistance in each of the warp and filling direction shall be determined by the residual breaking strength or the change in breaking strength as specified in the procurement document.

5.8 When the residual breaking strength is required, the breaking strength of the abraded specimen shall be determined and when the change in breaking strength due to abrasion is required, the breaking strength of the original and abraded materials shall be determined in each of the warp and filling directions. The breaking strength shall be determined by Method 5100 except that the gage length shall be 1 inch (25 mm) and the abrasion path shall be placed midway between the jaws.

5.9 When the state of destruction is required, the number of rotations required to produce specified destructions shall be read from the counter.

6. REPORT

6.1 When the end point is a specified number of cycles, the abrasion resistance of the sample unit shall be expressed as residual breaking strength or change in breaking strength.

6.1.1 Residual breaking strength shall be the average of the results obtained from the specimens tested in each of the warp and filling directions and shall be reported separately to the nearest 1 pound (to the nearest 1 N).

METHOD 5306

6.1.2 Change in breaking strength shall be the average of the results obtained from the specimens tested in each of the warp and filling directions respectively and shall be reported separately to the nearest 1.0 percent.

$$\text{Change in breaking strength, percent} = \frac{O - A}{O} \times 100$$

where:

O = breaking strength before abrasion.
A = breaking strength after abrasion.

6.2 When the end point is a required state of destruction, the abrasion resistance of the sample unit shall be the average of the number of cycles obtained from the specimens tested in each of the warp and filling directions respectively and shall be reported to the nearest 10 cycles.

6.3 Each individual value used to calculate the average shall also be reported.

7. NOTES

7.1 An abrasion machine of the type described may be obtained from Taber Instrument Co., 455 Bryant Street, North Tonawanda, NY 14120.

ROTARY ABRASION, DOUBLE HEAD

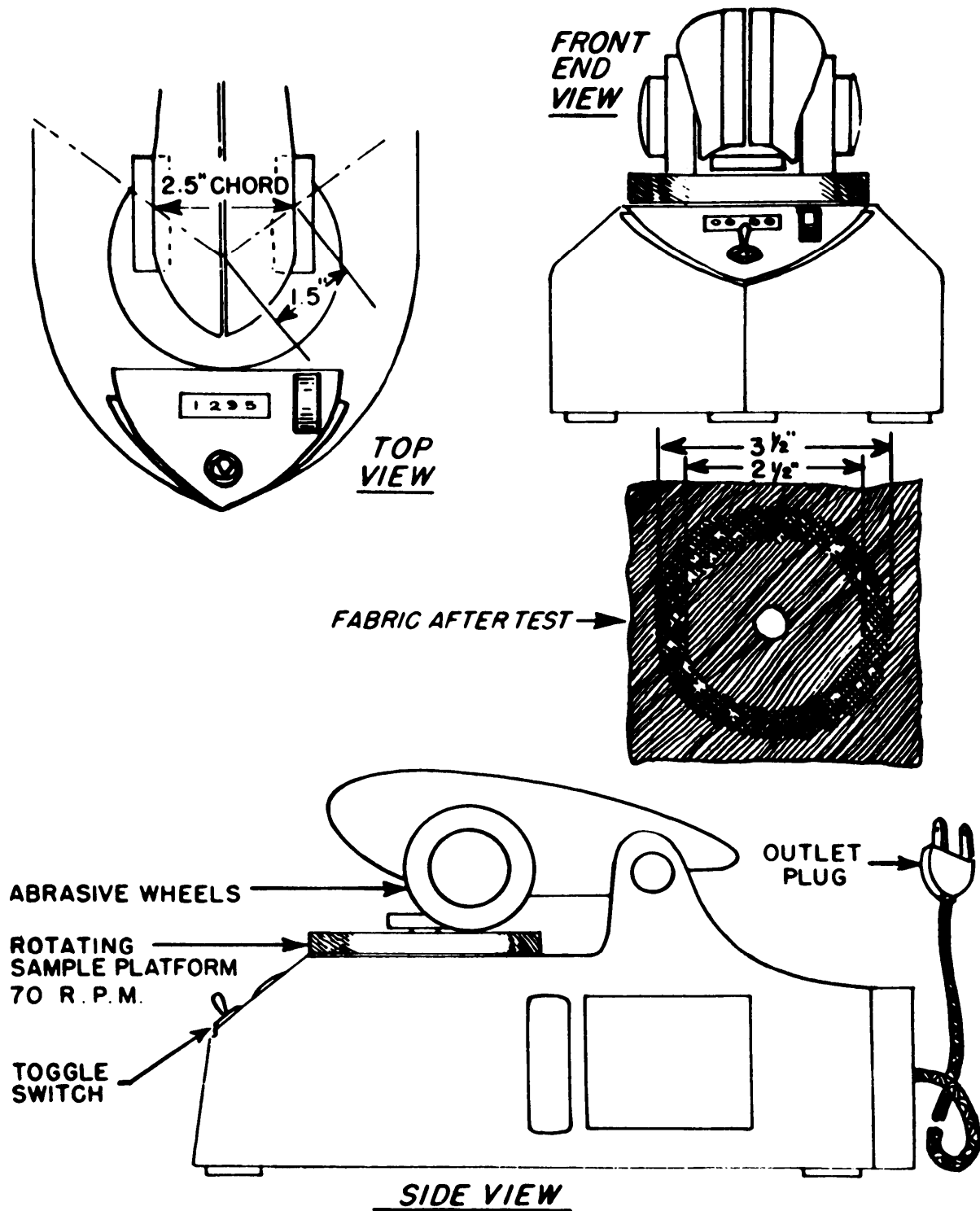

FIGURE 5306

METHOD 5308
July 20, 1978

ABRASION RESISTANCE OF CLOTH;
UNIFORM ABRASION (SCHIEFER) METHOD

1. SCOPE

1.1 This method is intended for determining the resistance to abrasion of cloths of all kinds. The abrasive action is applied uniformly in all directions in the plane of the surface of the cloth about every point in it. The settings of the machine; method of mounting specimens; conditions of test as dry or wet; and criteria to be used in evaluating abrasive wear in the test depend upon the nature of the cloth to be tested and use to be made of the results. These details as well as requirements for abrasion resistance should be specified in all documents calling for the use of the method. Only a general description of the equipment and procedures is given here (see 7.1).

2. TEST SPECIMEN

2.1 A circle of cloth 2.41 inches (61.2 mm), 3.41 inches (86.6 mm), or 3.81 inches (96.8 mm) in diameter or a cross cut from the cloth with arms 2 inches (51 mm) wide and 4.5 inches (114.3 mm) long, as specified in the procurement document.

3. NUMBER OF DETERMINATIONS

3.1 Unless otherwise specified in the procurement document, 10 specimens shall be tested from each sample unit.

4. APPARATUS AND METHOD CITED

4.1 Apparatus.

4.1.1 Abrasion machine. An abrasion machine, (figures 5308A and 5308B), consisting of abrading mechanism, specimen supporting mechanism, and driving mechanism (see 7.2). Essentially, the surface of the abradant lies in a plane parallel to the plane surface supporting the specimen and presses upon the specimen. The abradant and specimen rotate in the same direction at very nearly but not quite the same angular velocity, 250 r.p.m., on noncoaxial axes which are parallel to 0.001 inch (0.0254 mm). The small difference in speed is to permit each part of the specimen to come in contact with a different part of the abradant at each rotation.

FED. TEST METHOD STD. NO. 191A

METHOD 5308

4.1.1.1 Abrading mechanism. The abrading mechanism includes the abradant mounted at the lower end of a shaft; weights placed upon the upper end of the shaft to produce constant pressure between abradant and specimen throughout the test; lever and cam for raising and lowering the abradant; shaft; and weights. A counterweight for balancing the abradant and abradant shaft is used when tests are to be carried out at low pressures.

4.1.1.2 Specimen supporting mechanism. The specimen supporting mechanism provides for tension mounting of thinner, more flexible cloths and rigid mounting of thick, stiff cloths. For the first, a plastic presser foot 1/2, 1, 1-1/4, 1-1/2, or 2 inches (13, 25, 32, 38, 50 mm) in diameter, as called for, is mounted at the upper end of the specimen shaft to fix the area of the specimen to be abraded; a conical clamp seat fitted to the shaft rotates with it, but is free to move vertically on the shaft; a cam is provided for raising and lowering the clamp seat. The specimen clamp shown unassembled in figure 5308C fits on the seat, "C" in figure 5308C, and can be fastened to it by merely rotating it slightly to engage the two pins in the slots. The clamp and specimen assembly can be removed quickly for examination of the specimen and measurement of wear and returned to the machine without unclamping the specimen. When the clamp seat is lowered by turning the cam, the combined weight of the clamp seat and specimen clamp is suspended by the specimen over the presser foot. This places the specimen under constant tension throughout the test with take-up of any stretch in the specimen. Different tensions are applied to the specimen by changing the weight of the clamp seat, for example, by adding auxiliary weights. For rigid mounting of thick, stiff cloths such as carpeting and felts the specimen clamp and mounting aids shown in figure 5308D are used and the assembly screws onto the specimen shaft in place of the presser foot and specimen clamp seat.

4.1.1.3 Driving mechanism. The driving mechanism consists of a motor-driven auxiliary drive shaft connected to the abradant shaft and specimen shaft by spur gears.

4.1.1.4 Resettable counter, machine stop microswitch and thickness gauge. The machine is equipped with a resettable counter, "G" in figure 5308B, to indicate the number of rotations in a test; sensitive microswitch, "H" in figure 5308B, to stop the machine automatically when a tension-suspended specimen is worn through; thickness gauge, "I" in figure 5308B, when specified, for indicating changes in thickness of the specimen during a test.

4.1.2 Abradant. The working surface of the abradant disk shall be sufficiently greater in diameter than the specimen supporting the surface that the latter lies entirely inside the periphery of the abradant during a test. A spring steel blade abradant, "B" in figure 5308C, which is essentially constant in its action for a long period of use, shall be used for woven, felted, pile, and knitted fabrics, and a cross-cut tungsten tool steel blade abradant, "A" in figure 5308C, shall be used for coated cloths, unless otherwise specified in the procurement document. Emery cloth, sand paper, duck, canvas, or other cloth in a suitable holder may be specified.

METHOD 5308

4.1.3 Specimen clamp and mounting aids. Specimen clamp and mounting aids illustrated in figure 5308C and 5308D.

4.1.4 Capacitor and capacitance test set. Capacitor and capacitance test set when specified for evaluating the wear quantitatively.

4.1.4.1 The capacitor, figure 5308E, is of the guard-ring type. The guard electrode "B" is 1.2 inches (30.5 mm) outside diameter. The island electrode "C" is 0.4 inch (10.2 mm) in diameter. The electrodes are so arranged that the specimen clamp "D" can be readily inserted with the worn area of the specimen in it over the island and guard electrodes and the clamp suspended by the specimen, as it was in the abrasion testing machine. A third electrode "E" mounted in a heavy hinged lid "F" can be swung down to a fixed stop after the specimen and clamp are in place. The distance between the third electrode and the island electrode can be adjusted to precise known values with the micrometer head, "I", of which the third electrode is a part. The capacitance test set is the commercial instrument which operates at a frequency of 465, 000 cycles per second and is usually used to measure the capacitance between the electrodes of vacuum tubes.

4.2 Method cited.

Method 5104, Strength and Elongation, Breaking of Woven Cloth;
Ravel Strip Method.

5. PROCEDURE

5.1 The cross-cut tungsten tool steel blade abradant shall be used for coated cloths, the spring steel blade abradant for all others, unless otherwise specified in the procurement document.

5.2 The load on the abradant, the tensioning load on tension-suspended specimens, and the size of the presser foot shall be as specified in the procurement document. If not specified, these elements shall be chosen to be such that the duration of the test to the end point for the least resistant material in a series to be compared is not less than 1000 rotations and/or the duration of the test for the most resistant is of the order of 20,000 rotations.

5.3 The end point of the test shall be as specified in the procurement document. It may be a stated change in some characteristic as electrical capacitance, thickness, breaking strength, color, luster, cloth structure, napping or pilling after a stated number of rotations of abrasion, or the number of rotations required to produce the stated change, or the number required to completely wear through the cloth. When this last criterion is specified, the number of revolutions at which the cloth no longer supports the clamp assembly and the clamp drops, actuates the microswitch and stops the machine is the end point.

METHOD 5308

5.4 The face of the cloth (weave face, finished face, coated side, etc.) shall be the surface subjected to abrasion, unless otherwise specified in the procurement document.

5.5 When wet abrasion resistance is to be tested, the specimen shall be immersed in water prior to mounting in the clamp. The area to be abraded is then flooded with water and the machine is started. After each 1000 rotations of the abradant, the machine is stopped and the area being abraded again flooded with water. Alternatively, water shall be supplied continuously during the test to the center of the abraded area through a small hole in the presser foot and specimen shaft.

5.6 A test shall be carried out as follows: Mount the specimen in the appropriate clamp as illustrated in figure 5308C, taking care that it is clamped evenly and securely without distortion. Place the specimen assembly in position in the machine, and if it is to be tension-suspended rotate the lower cam to stretch the specimen uniformly over the presser foot. Lower the abradant on the specimen by rotating the upper cam. Set the counter at zero and start the machine.

5.7 If changes in thickness are required, the thickness shall be read on the gage immediately after starting the machine and at regular intervals during the test.

5.8 The test shall be continued for the required number of rotations of abrasion or until the specimen is to be inspected. The machine shall be stopped, the abradant raised by the upper cam, the clamp assembly raised by the lower cam to release the tension on the specimen, and the clamp and specimen removed from the machine.

5.9 The specimen shall be inspected or measured as required in the procurement document without removing it from the clamp. Replace the assembly in the machine and continue the test, repeating the inspection at intervals as required. If the test is to be carried to complete destruction of the test area, continue until the specimen no longer supports the clamp assembly and the latter drops, actuates the microswitch, and stops the machine.

5.10 Evaluation.

5.10.1 The resistance to abrasion shall be evaluated as specified in the procurement document.

5.10.2 When the test is to run to complete destruction of the cloth, the resistance to abrasion of the specimen shall be the number of rotations of abradant required to terminate the test automatically, that is, the number of rotations at which the cloth no longer supports the clamp assembly and the clamp drops, throws the microswitch, and stops the test.

METHOD 5308

5.10.3 When change in electrical capacitance is taken as the measure of abrasion resistance, the following measurements shall be made:

Where: C_a = Capacitance of the air in the capacitor without the specimen;
 C_o = Capacitance of the unabraded specimen prior to insertion in the abrasion machine;
 C_x = Capacitance of the abraded specimen after a specified number of rotations or at a predetermined end point.

The value of degree of destruction, "Q", in percent, shall be calculated as follows:

$$Q = \frac{C_o - C_x}{C_o - C_a} \times 100$$

5.10.4 When change in thickness is required, the thickness of the specimen at the beginning of and at regular intervals during abrasion shall be read from the thickness gage.

5.10.5 When the change in breaking strength or residual breaking strength is specified, the breaking strength in each of the warp and filling directions of the original and abraded material shall be determined as described in Method 5104 except that (1) the distance between the jaws of the machine at the start of the test shall be 1 inch (25 mm) and (2) the abraded portion of the specimen shall be placed midway between the jaws of the machine.

5.10.6 When the effect of visual change in luster, color, cloth structure, napping, pilling, or other characteristic is required, the specimen shall be evaluated as described in the required method.

5.10.7 Unless otherwise specified in the procurement document, change in thickness, breaking strength, or other characteristic shall be calculated as follows:

$$\text{Change in characteristic, percent} = \frac{O - E}{O} \times 100$$

Where: O = value before abrasion.

E = value after abrasion.

6. REPORT

6.1 When a state of destruction is specified as the end point, unless otherwise specified in the procurement document, the abrasion resistance of the sample unit shall be the average of the number of rotations obtained from the specimens tested, and shall be reported to the nearest 10 rotations.

METHOD 5308

6.1.1 Each individual value used to calculate the average shall also be reported.

6.2 When the number of rotations is specified as the end point, the resistance to abrasion of the sample unit shall be reported as the change in electrical capacitance, thickness, or breaking strength, the residual breaking strength, or the effect of visual change in luster, color, fabric structure, napping, pilling, or other characteristic, as specified in the procurement document.

6.2.1 Unless otherwise specified in the procurement document, change in electrical capacitance, thickness, breaking strength, or other characteristic shall be the average of the results obtained from the specimens tested, and shall be reported to the nearest 1.0 percent. When applicable, the values obtained for the warp and filling directions shall be reported separately.

6.2.1.1 Each individual value used to calculate the average shall also be reported.

6.2.2 Unless otherwise specified in the procurement document, residual breaking strength shall be the average of the results obtained from the specimens tested, and shall be reported to the nearest 1 pound (nearest 5 N). When applicable, the value obtained for the warp and filling directions shall be reported separately.

6.2.2.1 Each individual value used to calculate the average shall also be reported.

6.2.3 Unless otherwise specified in the procurement document, the effect of visual change in luster, color, cloth structure, napping, pilling, or other characteristic, as specified in the procurement document, shall be reported for each specimen tested.

7. NOTES

7.1 The mathematical basis for this method is given in the Journal of Research of the National Bureau of Standards 39, 1 (1947), Research Paper RP 1807. The machine and its uses are described in the Journal of Research of the National Bureau of Standards 42, 481 (1949), Research Paper RP 1988.

7.2 An abrasion machine of the type described in this method is manufactured by Frazier Precision Instrument Company, Silver Spring, MD 20907.

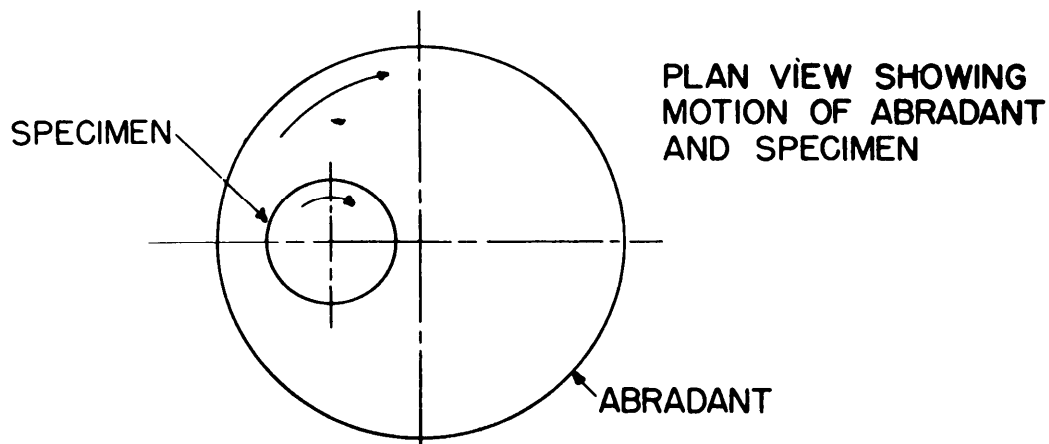
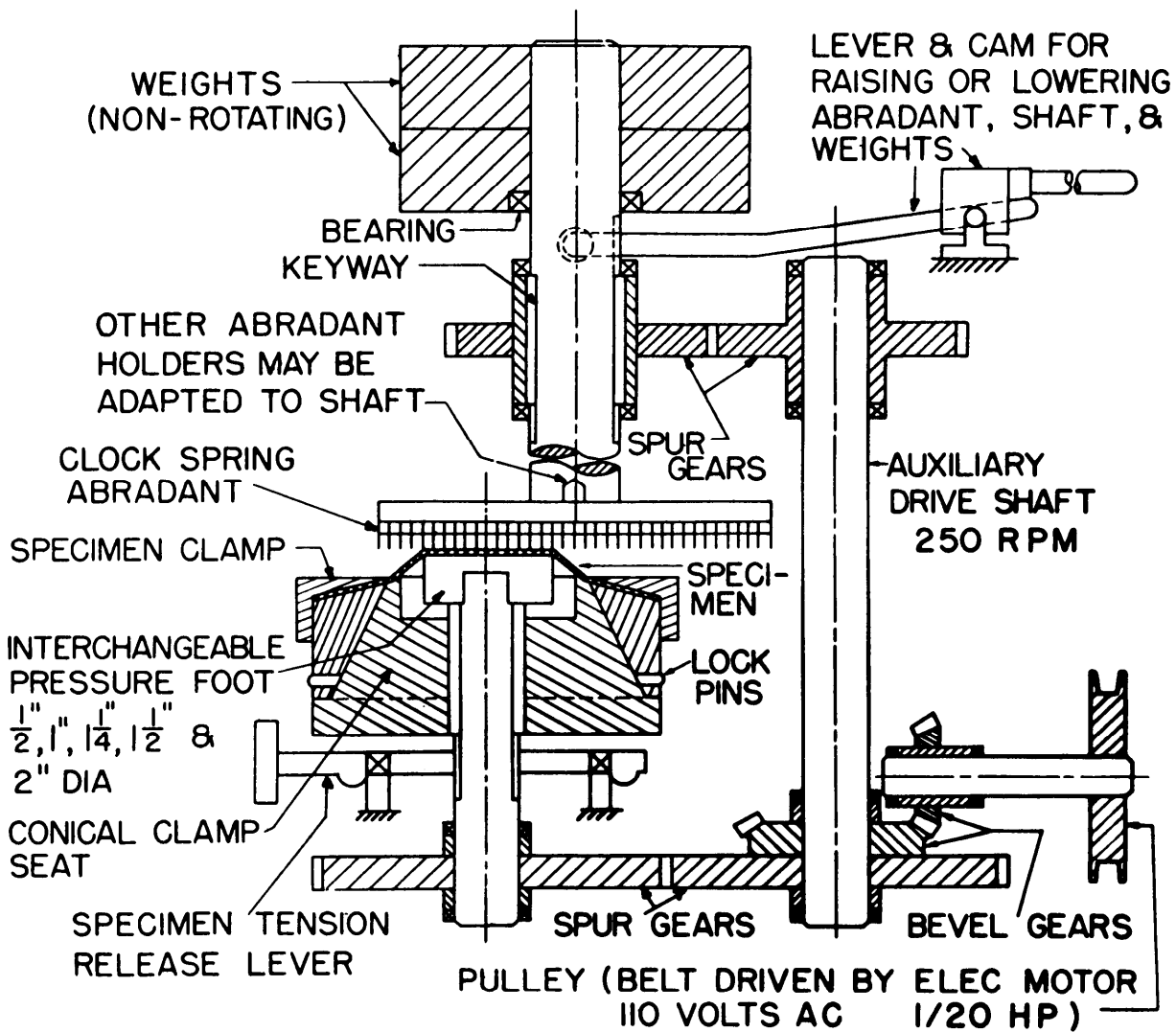
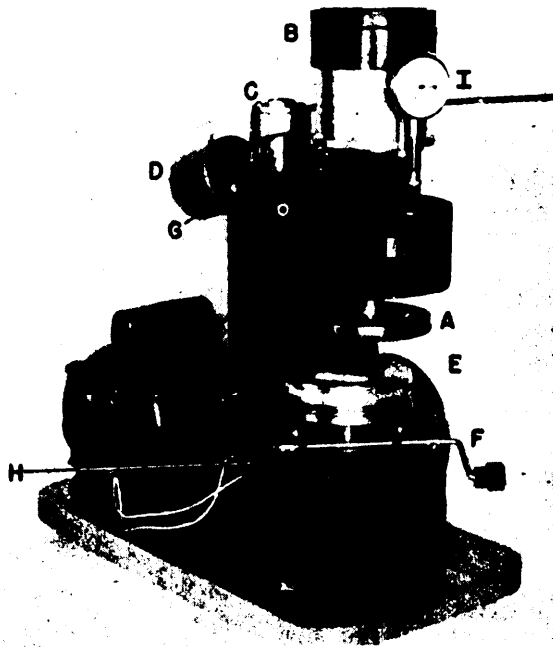

FIGURE 5308A Schematic drawing of Schiefer abrasion testing machine



- A. Abradant
- B. Weights on abradant shaft
- C. Cam and lever system for raising the abradant shaft, abradant, and weights
- D. Counterweight for balancing abradant and abradant shaft when tests are to be made at low pressures
- E. Specimen in place ready for test
- F. Cam for raising and lowering the specimen clamp seat
- G. Counter
- H. Microswitch
- I. Thickness gage

FIGURE 5308B - SCHIEFER ABRASION TESTING MACHINE

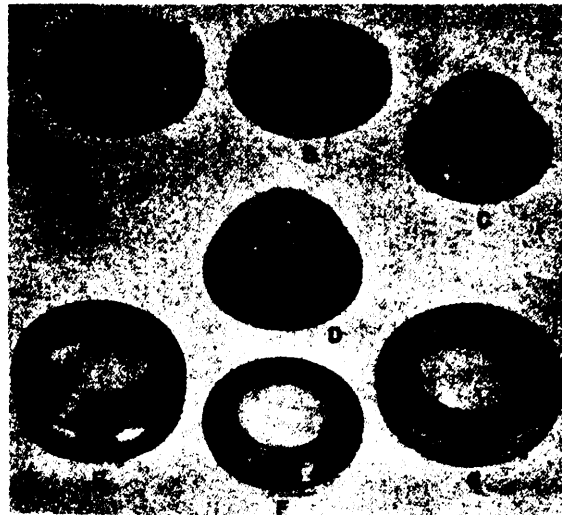

FIGURE 5308C - Abradants; specimen clamp seat; template and clamp for thinner flexible cloths which are to be held in the machine under tension.

- A Cross-cut tungsten tool steel blade abrasant
- B Spring steel blade abrasant
- C Specimen clamp seat
- D Template, which is placed under E to bulge the specimen when mounting it
- E Base of specimen clamp, over which specimen is placed
- F Pressure ring, which is placed on specimen
- G Outer ring which is screwed down over F to hold the assembly together

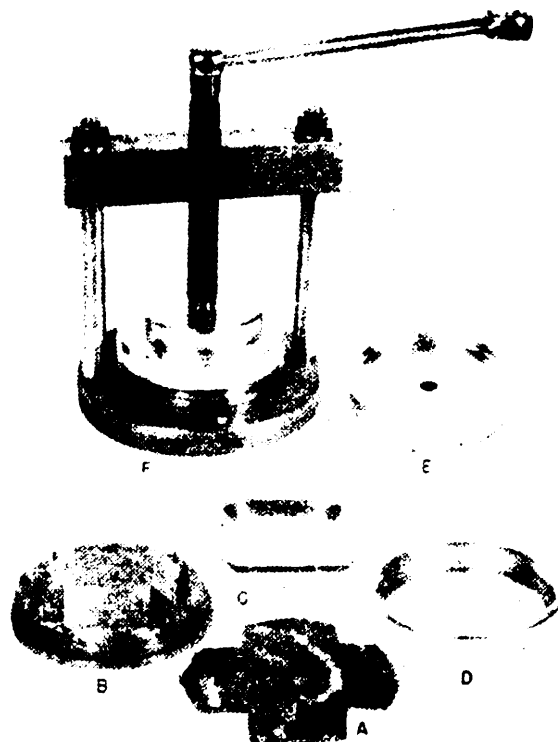

FIGURE 5308D - Specimen clamp and mounting aids for thick, stiff cloth such as carpeting and felts, which are to be mounted rigidly.

- A Specimen
- B Base of clamp
- C Clamping plate
- D Outer ring
- E Pressure disk
- F Assembly in screw press for forcing C down over specimen in order to tighten D and hold specimen firmly on the base

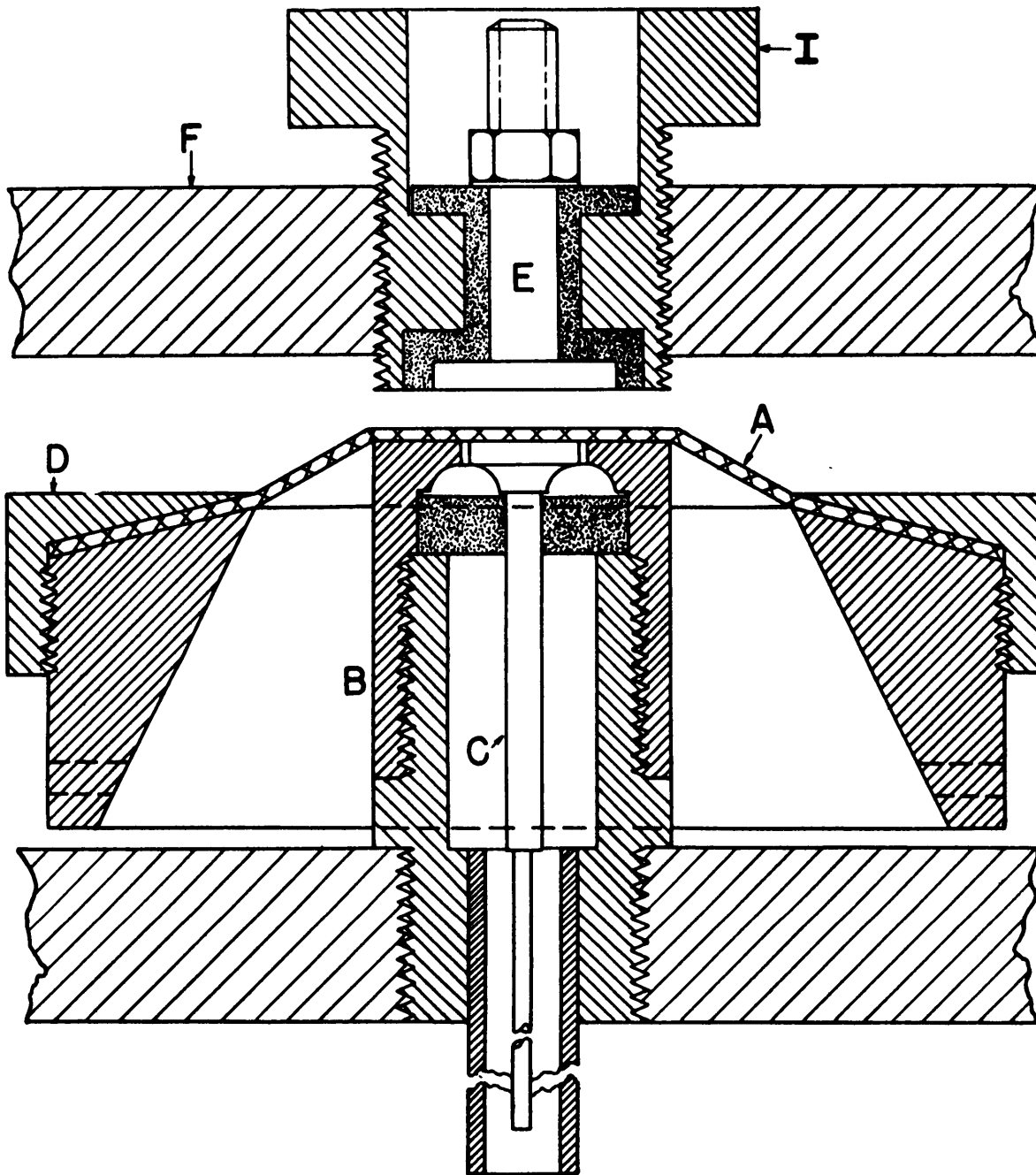

FIGURE 5308E - Schematic drawing of capacitor.

- | | |
|---------------------|---------------------|
| A. Specimen | E. Third electrode |
| B. Guard electrode | F. Heavy hinged lid |
| C. Island electrode | I. Micrometer head |
| D. Specimen clamp | |

ABRASION RESISTANCE OF TEXTILE WEBBING

1. SCOPE

1.1 This method is intended for determining the resistance to abrasion of textile webbing.

2. TEST SPECIMEN

2.1 The specimen shall be the full width of the material being tested and shall have a minimum length of 54 inches (1372 mm).

3. NUMBER OF DETERMINATIONS

3.1 Unless otherwise specified in the procurement document, five specimens shall be tested from each sample unit.

4. APPARATUS

4.1 Webbing abrasion tester. The webbing abrasion tester (principle illustrated in Figure 5309) consists of a power driven oscillating drum. One end of each specimen is attached to the drum and the other end passing over a hexagonal steel rod is attached to a weight. The hexagonal rod is so fixed as to subject the webbing specimen to abrasion on two adjacent edges as the drum moves the specimen across the rod.

4.1.1 Weight "B", unless otherwise specified in the procurement document, shall be 2 pounds \pm 2 ounces (0.91 kg \pm 0.06 kg) for specified breaking strengths up to 1000 pounds \pm 4450 N), 4 pounds \pm 2 ounces (1.81 \pm 0.06 kg) for breaking strengths of 1000 to 3000 pounds (4450 to 13350 N), and 5.2 pounds \pm 2 ounces (2.4 \pm 0.06 kg) for breaking strengths over 3000 pounds (13350 N).

4.1.2 Steel hexagonal rods "C" shall be 0.250 \pm 0.001 inch (6.35 \pm 0.03 mm) when measured across opposite flat sides and the radius of the edges shall be 0.020 \pm 0.004 inch (0.5 \pm 0.1 mm). The steel shall have a cold drawn finish and a Rockwell Hardness of B-97 to B-101 (see 6.1). The edges of the hexagonal rods shall not have any burrs, nicks or scale.

4.1.3 Drum "D" shall have an outside diameter of 16 inches (406 mm) with a suitable means for attaching the specimen to be tested without damage to specimen.

4.1.4 The crank "E" and crank-arm "F" shall be attached to the drum in such a manner that when the specimen is attached to the drum, the specimen during the test will oscillate over the hexagonal rod the required distance during each stroke and at the required rate.

METHOD 5309

4.1.5 The hexagonal rod shall be so placed that specimen "A" with the weight attached to one end and the other end passing over the hexagonal rod and attached to the drum will form an angle of 85 ± 2 degrees "H".

5. PROCEDURE

5.1 Unless otherwise specified in the procurement document, the specimens tested shall be conditioned and tested under standard conditions in accordance with Section 4 of this Standard.

5.2 Attach the required weight to one end of the specimen, pass the other end over the hexagonal rod and attach to the drum. The length of the specimen shall be adjusted, without altering the original length, so that the specimen shall oscillate across the hexagonal rod and that each end of the abraded area is equidistant from the ends of the specimen.

5.3 The edges of each new hexagonal rod shall be identified as 1 through 6, and only alternate edges (e.g., 1, 3, and 5) shall be used for abrading. No abrading edge shall be used more than once.

5.4 Oscillate the drum so that the specimen is given a 12 ± 1 inch (305 ± 25 mm) traverse over the rod at the rate of 60 ± 2 strokes (30 ± 1 cycles) per minute for 5000 strokes (2500 cycles). One single stroke is 12 ± 1 inches (305 ± 25 mm) in one direction only.

5.5 The characteristics and methods for determining the degree of resistance to abrasion shall be specified in the procurement document.

5.6 Calculation of results.

5.6.1 Percent change in the characteristic being evaluated to determine resistance to abrasion shall be calculated as follows:

$$\text{Percent change in characteristic} = \frac{A - E}{A} \times 100$$

Where: A = Value before abrasion
E = Value after abrasion

6. REPORT

6.1 The resistance to abrasion shall be reported as the change in characteristics as specified in the applicable test method or procurement document.

7. NOTES

7.1 To reduce variability, and in case of disagreement of results the hexagonal rods described in this method which have been cold drawn from the same die should be used and may be purchased from Narrow Fabrics Institute, Inc., 271 North Avenue, New Rochelle, NY 10801.

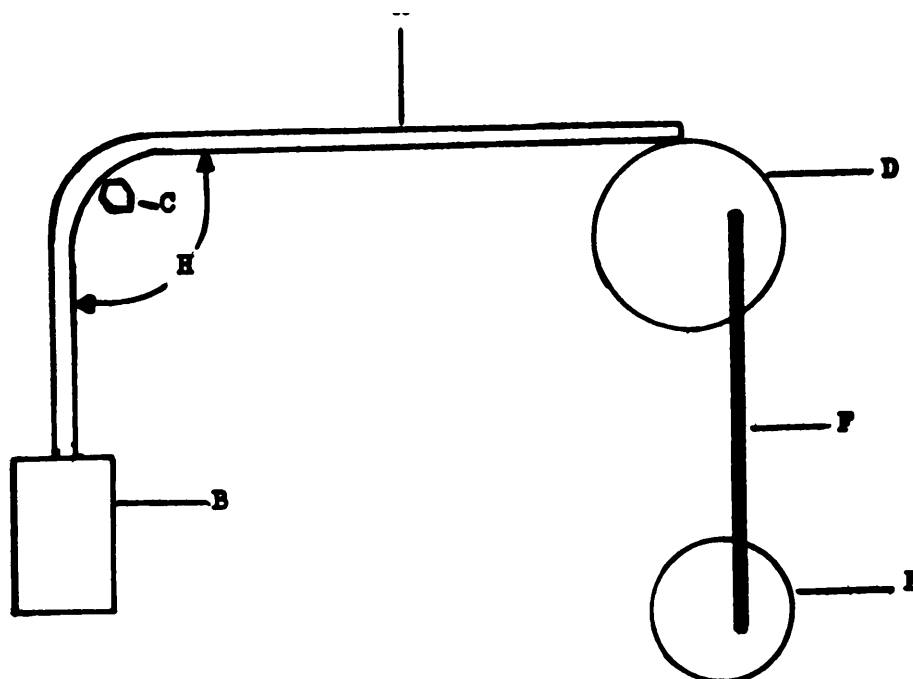

- A. Specimen
- B. Weight
- C. Steel hexagonal rods
- D. Drum
- E. Crank
- F. Crank arm
- H. 85° angle

FIGURE 5309 - WEBBING ABRASION TESTER

METHOD 5310
July 20, 1978

APPEARANCE-RETENTION OF CLOTH; PILLING AND SURFACE WEAR

1. SCOPE

1.1 This method is intended for determining the resistance of woven and knitted fabrics to a pilling and combined wear-pill. Pilling is defined as the formation of bunches or balls of fibers on the surface of a fabric. In a combined wear-pill test, pilling characteristics and surface wear are evaluated after a given period of wear. Surface wear resistance of cloth is defined as resistance to wear of felt cover, nap, flock, or coating. Pilling is evaluated by direct comparison of inked specimens with visual standards. The combined wear-pill test is evaluated in terms of change in appearance.

2. TEST SPECIMEN

2.1 The specimen shall be a circle of cloth 4-1/2 inches (114 mm) in diameter. No two specimens shall contain the same warp or filling yarns in woven cloths, and the same wales or courses in knitted cloths.

3. NUMBER OF DETERMINATIONS

3.1 Unless otherwise specified in the procurement document, five specimens shall be tested from each sample unit.

4. APPARATUS

4.1 Appearance retention tester and accessories. An appearance retention tester (figure 5310A and 7.2) and accessories, consisting, in general, of removable circular magnetic specimen holders (A), a non-rotating specimen holder support (B), which is free to move up and down having a rest pin for disengaging the specimen holder and support assembly. Removable 2.0 lb (0.9 kg) weight (C), and abradant holder (D), a motor drive mechanism for imparting motion to the abradant holder, and a timer (E) for controlling the duration of the test.

4.1.1 The magnetized specimen holder (A) slips onto the bottom of the specimen holder support (B), and is held there magnetically. The foam support material on the specimen holders shall have contact test areas of 1, 2, or 5 square inches (6.4, 12.9, or 32.3 cm²). The specimen holder shall have a groove around the side into which a rubber ring (F) fits snugly for securing the specimen to the specimen holder. Unless otherwise specified in the procurement document, the size of the contact area on the specimen holder for this test shall be 2 square inches (12.9 cm²).

FED. TEST METHOD STD. NO. 191A

METHOD 5310

4.1.2 A mounting cone (G), for use in uniformly mounting specimens on the specimen holder.

4.1.3 The weights of the holder (A) and support (B), together with the removable weight (if necessary) shall be such as to give the required contact pressure (see 5.2) for the size of specimen holder being used.

4.1.4 An abradant holder (D), for retaining either a rigid or flexible abradant, such as woven plastic, having a speed of 86 ± 3 revolutions per minutes, with a displacement of 1.5 inches (38 mm) in diameter.

4.1.5 The motor drive imparts a uniform circular motion to the abradant holder without rotation about its center.

4.1.6 The discs used for each test shall be as follows:

- a. Pilling disc - Shall be made of a polyurethane foam.
- b. Wear disc - Shall be a silicone carbide with a designation of 7K for woven cloth, and 5T for knit cloth.

4.1.7 Black or white inking papers for preferentially inking pills on the test specimen.

5. PROCEDURE

5.1 Conditions of specimens for test.

5.1.1 Dry. When the specimen to be tested is in a dry state, it shall be brought to moisture equilibrium under standard conditions in accordance with Section 4 of this Standard.

5.1.2 Wet. Unless otherwise specified in the procurement document, when the specimen is to be tested in a wet state, the moisture pick up of the cloth shall be 60 ± 5 percent.

5.2 Contact pressure. Unless otherwise specified in the procurement document, the contact pressure applied to the test specimens by abradant, and the duration of the test shall be as follows:

- a. Pilling test. The contact pressure shall be 0.50 pounds per square inch (3.4 kPa), and the pilling disc shall be used for 5 minutes.
- b. Combined wear-pill test:

METHOD 5310

Woven cloth. The contact pressure shall be 0.50 pounds per square inch (3.4 kPa), using the 7K wear disc for 10 cycles, followed by 0.50 pounds per square inch (3.4 kPa) pressure with the pilling disc for 5 minutes.

Knit cloth. The contact pressure shall be 0.50 pounds per square inch (3.4 kPa) using the 5T wear disc for 10 cycles, followed by 0.50 pounds per square inch (3.4 kPa) pressure with the pilling disc for 5 minutes.

5.3 Calibrate and periodically check the operation, using a standard fabric of known pilling and wear propensity. The abrasants for the pilling and wear tests should be changed when they fail to pill or abrade a standard fabric (see 7.1) with uniform results.

5.4 Unless otherwise specified in the procurement document, the face of the cloth (weave face, finished face, coated face, etc.) shall be the surface subjected to the abrasant and pilling discs.

5.5 The specimen shall be placed over the specimen holder. The mounting cone shall be set upright over the specimen, and the rubber ring rolled down over the cone until it slips off the bottom of the cone and seats over the specimen in the side groove running around the specimen holder. The mounting cone shall then be removed, and the specimen and holder assembly slipped up onto the adapter at the bottom of the specimen holder support. When in this position, the surface to be tested shall be facing down. The abrasant shall be placed face up over the surface of the abrasant holder, the washer placed over the abrasant, and the cap screwed down. The specimen shall be lowered onto the surface of the abrasant by disengaging the support from the rest pin and allowing the rest pin to fall through the slot or hole in the support cap. The timer shall be set and the machine run for the required time.

5.6 Pill rating. At the end of the test period, the specimen holder with the specimen shall be removed from the support adapter with the contact surface of the specimen down. The specimen holder shall be moved slowly back and forth by hand over the surface of the inking paper 10 times, without applying any downward pressure, until the projecting pills have been inked (see 6.1). Black inking paper shall be used for light colored materials and white inking paper for dark colored materials.

5.7 Evaluation.

5.7.1 Standard sample.

5.7.1.1 Pilling. When a standard sample has been established for pilling the inked specimen shall be compared to the inked standard and rated as follows:

METHOD 5310

Pass: When pill count is equal to or less than is shown by the standard.
Fail: When pill count is more than is shown by the standard.

5.7.1.2 Combined wear-pill. When a standard sample has been established for the combined wear-pill test, the test specimen shall be compared to the standard and rated as follows:

Pass: When pill count or degree of surface wear is equal to or less than the standard.
Fail: When pill count or degree of surface wear is more than the standard.

5.7.2 No standard sample.

5.7.2.1 Pilling. When a standard sample has not been established, the inked specimen shall be compared with the standard pill rating chart (see figure 5310B) and assigned a value corresponding to the nearest standard rating.

5.7.2.2 Combined wear-pill. When a standard sample has not been established for the combined wear-pill test the test specimen shall be compared with the original material and evaluated visually for changes of luster, color, fuzzing, removal of nap, cover, flock, or coating, etc., and shall be evaluated in accordance with the following adjective ratings:

Good: Not more than a slight degree of pilling or wear on the surface of the cloth.
Fair: Appreciable but not excessive pilling or wear on the surface of the cloth.
Poor: Excessive pilling or wear on the surface of the cloth.

"Appreciable pilling or wear to the surface of the cloth" means a change that is immediately noticeable in comparing the tested specimen with the original comparison specimen. If closer inspection or a change of angle of light is required to make apparent slight wear to the cloth, the change is not considered appreciable.

6. REPORT

6.1 Unless otherwise specified in the procurement document, each specimen for the pilling test and combined wear-pill test shall be evaluated separately and reported separately for each of the 5 specimens in the sample unit.

6.2 Standard sample. When a standard sample has been established, the pilling and combined wear-pill tests shall be reported as "pass" or "fail". If one specimen is reported "fail" the sample unit is considered to have failed.

METHOD 5310

6.3 No standard sample. Unless otherwise specified in the procurement document, when a standard sample has not been established, the results shall be reported as follows:

6.3.1 Pilling test. The 5 inked test specimens in the sample unit shall be compared with the standard pill rating chart, and the nearest standard rating reported.

6.3.2 Combined wear-pill test. The 5 test specimens shall be reported as "pass" or "fail" in accordance with the adjective rating requirement of the procurement document. When failure is reported the severest departure, i.e. the actual rating "fair" or "poor" of the change of test specimen, shall also be distinguished and reported. When one specimen is reported as "fail", the sample unit is considered to have failed.

7. NOTES

7.1 The standard fabric to be used in calibrating test apparatus is obtainable from the Countersurveillance and Process Technology Branch, US Army Natick Research and Development Command, Natick, MA 01760.

7.2 An Appearance-Retention Tester and accessories of the type described in this method are manufactured by the:

Custom Scientific Instruments, Inc.,
13 Wing Drive
Whippany, NJ 07981

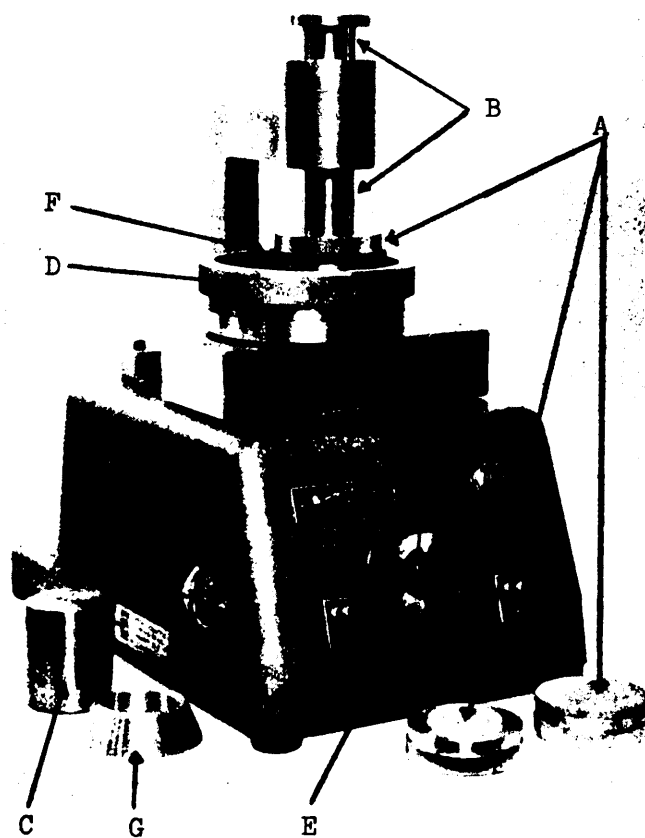

LEGEND

- A. Circular Specimen Holder
- B. Specimen Holder Support
- C. Removable Weight
- D. Abradant Holder
- E. Timer
- F. Rubber Ring
- G. Mounting Cone

FIGURE 5310A



FIGURE 5310 B

FED. TEST METHOD STD. NO. 191A

PILLING RESISTANCE OF TEXTILE FABRICS;
BRUSH AND SPONGE METHOD

1. SCOPE

1.1 This method is intended for determining the resistance of textile fabrics to pilling and fuzzing.

2. TEST SPECIMEN

2.1 Standard sample. Unless otherwise specified in the procurement document, when a standard sample has been established, three specimens shall be cut from the sample unit, and one specimen shall be cut from the standard sample. The specimens shall be 9 by 10 inches (229 by 254 mm), with the longer dimension in the direction of the filling.

2.2 No standard sample. Unless otherwise specified in the procurement document, when a standard sample has not been established, four specimens shall be cut from the sample unit, one specimen being retained, untested, for comparison. The specimens shall be 9 by 10 inches (229 by 254 mm), with the longer dimension in the direction of the filling.

2.3 The specimens shall be taken from the center and sides of the sample unit, with those taken from the sides, care shall be taken so that no selvage is included as part of the specimen. No two specimens shall be taken from areas containing the same warp or filling yarns.

3. NUMBER OF DETERMINATIONS

3.1 Unless otherwise specified in the procurement document, three specimens shall be tested from each sample unit.

4. APPARATUS

4.1 Brush and sponge pilling tester (see 7.2).

4.1.1 Eight nylon brushes, 10 mil (0.25 mm) black nylon bristles 15/16 inches (24 mm) long, 1-1/4 inches (32 mm) over-all height including backing (see 7.3).

4.1.2 Brush holders, two strip channel, 31 inches (787 mm) long.

4.1.3 Brush holder mountings, 1-3/8 inches (35 mm) center hole to center hole.

METHOD 5320

4.1.4 Sponges 2 x 4 x 6 inches (51 x 102 x 152 mm) (see 7.4).

4.1.5 Sandpaper.

4.1.5.1 No. 4/0 sandpaper for backing material of specimen holder and sanding sponges.

4.1.5.2 No. 1-1/2 flint paper for sanding brushes.

4.1.6 Six specimen holders, 1.37 ± .01 lb (625 ± 5 g), covered with 4/0 sandpaper.

5. PROCEDURE

5.1 Unless otherwise specified in the procurement document, all tests shall be performed under standard conditions in accordance with Section 4 of this Standard.

5.2 Calibration. Calibrate and periodically check the pilling tester against a standard fabric (see 7.1) of known pilling resistance. The machine can be brought back into calibration by resurfacing the sponges and cleaning the brushes.

5.2.1 Sponges should be resurfaced by sanding or sawing off a thin layer, followed by sanding. If this fails, new sponges will have to be installed, and sanded for at least 24 hours after mounting on the brush board. Flint paper shall be mounted on the specimen holders for sanding brushes. Sponges should then be cleaned with a vacuum cleaner to remove lint and sponge particles which tend to reduce sponge effectiveness.

5.2.2 Brushes should be cleaned with solvent, lint removed with a hand card, and protruding bristles clipped periodically.

5.3 Mount the test specimens on the holders with the warp direction of the fabric parallel to the long dimension of the holder and with the face exposed, and with sufficient tension to prevent wrinkling during testing.

5.3.1 Place the brush board on the machine with the bristles pointing upward. Set the specimen holders over the positioning pins so that the face of the test specimens makes contact with the bristles.

5.3.2 Unless otherwise specified in the procurement document, the specimens shall be brushed for 5 minutes. Remove the specimen holders and replace the brush board with the sponge-board. Reset the specimen holders in their respective positions and sponge the brushed specimens for 5 minutes.

METHOD 5320

5.4 Evaluation.

5.4.1 Standard sample. When a standard sample has been established, the test specimens shall be compared with the specimen of the standard sample and rated as follows:

Pass: Equal to or better than the standard sample.

Fail: Inferior to the standard sample.

5.4.2 No standard sample. When a standard sample has not been established, the test specimens shall be compared to the untested specimen and rated as follows:

Good: No pilling or fuzzing.

Fair: Moderate pilling or fuzzing (not objectionable).

Poor: Heavy pilling or fuzzing (objectionable).

6. REPORT

6.1 Standard sample. When a standard sample has been established, the results of testing each of the three specimens shall be reported as "pass" or "fail". If one specimen is reported as "fail", the sample unit is considered to have failed.

6.2 No standard sample. When a standard sample has not been established, the results of testing each of the three specimens in the sample unit shall be reported as "pass" or "fail" in accordance with the adjective rating requirement of the procurement document. When failure is reported the severest departure, i.e. the actual rating "fair" or "poor" of the change of test specimen, shall also be distinguished and reported. When one specimen is reported as "fail", the sample unit is considered to have failed.

7. NOTES

7.1 The standard fabric to be used in calibrating test apparatus is obtainable from the Countersurveillance and Process Technology Branch, US Army Natick Research and Development Command, Natick, MA 01760.

7.2 The brush and sponge pilling tester may be purchased from Custom Scientific Instruments, Inc., 13 Wing Drive, Whippany, NJ 07981.

7.3 The brushes No. 8B9041-13 and brush holders Series 9C7200 may be purchased from Fuller Brush Company, Hartford, CT 06115.

7.4 The sponges are DuPont No. 8A (with softener removed).

METHOD 5400
July 20, 1978

SEWABILITY OF WOVEN CLOTH; YARN SEVERANCE METHOD

1. SCOPE

1.1 This method is intended for determining the sewability of woven cloth by using the number of percent of yarns completely severed in sewing as the criterion.

1.2 Since the majority of the principal seams in clothing are parallel to the warp direction of the cloth, and filling yarn severance usually predominates, the described procedure is for filling yarn severance. When warp yarn severance is specified in the procurement document, the word "warp" for "filling" and the word "filling" for "warp" shall be substituted in the applicable paragraphs.

2. TEST SPECIMEN

2.1 The test specimen shall be a 3 inch (76 mm) portion of the seam prepared as specified in 5.1.

3. NUMBER OF DETERMINATIONS

3.1 Unless otherwise specified in the procurement document, five specimens shall be tested from each sample unit.

4. APPARATUS AND METHOD CITED

4.1 Apparatus.

4.1.1 The apparatus shall be as described in Method 5110, except that the tensile tester is not required.

4.1.2 Pick needle or similar device.

4.2 Method cited.

Method 5110, Sewability of Woven Cloth; Seam Efficiency Method.

5. PROCEDURE

5.1 Preparation of specimen. The specimens shall be prepared as follows:

METHOD 5400

5.1.1 Standard seam. Unless otherwise specified in the procurement document, the test specimens shall be cut from a seamed strip prepared as described in Method 5110, except that the panel of cloth shall be 8 by 48 inches (203 by 1220 mm) and shall be cut before seaming into 2 strips 4 inches wide (102 mm), with the long dimension perpendicular to the filling yarns. The seam shall be inspected for proper folding and stitching.

5.1.1.1 The specimens shall be cut 3 inches (76 mm) wide at random intervals along the length of the seam. No specimen shall be taken within 6 inches (152 mm) of either end of the seam where sewing started or finished, nor from any section that was improperly formed.

5.1.1.2 The 2 rows of sewing thread shall be removed from the 3-inch (76 mm) specimen and the bottom layer of the cloth reserved.

5.2 Unless otherwise specified, all tests shall be performed on material conditioned as specified in Section 4 of this Standard.

5.3 The edge of the cloth turned in to the seam and the adjacent row of needle holes on the specimen shall be cut away to within 1/8 inch (3 mm) of the inside test row of needle holes. The middle 1 inch (25 mm) of the specimen shall then be cut out and the warp yarns removed, using a pick needle or similar device, to a point slightly beyond the stitching line.

5.4 The number of completely severed warp yarns parallel to the direction of the seam shall be counted.

5.5 The total number of filling yarns and the number of filling yarns which have been severed shall be counted.

5.6 Calculation of results. The percent filling yarn severance shall be calculated as follows:

$$\text{Filling yarn severance, percent} = \frac{\text{No. of filling yarns severed per inch (/cm)}}{\text{Total filling yarns per inch (/cm)}} \times 100$$

6. REPORT

6.1 The filling yarn severance of the sample unit shall be the average of the results obtained from the specimens tested, and shall be reported to the nearest 0.1 percent.

6.2 The average number of completely severed warp yarns per inch (yarns/cm) shall be reported to the nearest whole number.

6.3 Each individual value used to calculate the average shall also be reported.

METHOD 5404
July 20, 1978

SEWABILITY OF CLOTHS CONTAINING THERMOPLASTIC
SYNTHETIC FIBERS OR YARNS

1. SCOPE

1.1 This method is intended for determining whether cloths containing thermoplastic synthetic fibers or yarns can be sewn at high production speeds without the generation of needle heat which will cause the fibers or filament to melt and encrust the needle.

2. TEST SPECIMEN

2.1 Unless otherwise specified in the procurement document, the test specimen shall be 4 pieces of cloth, each 6 inches wide (152 mm) and 2 yards (1.8 m) long, cut with the long dimension parallel to the warp direction. No selvage shall be included in the sample tested.

3. NUMBER OF DETERMINATIONS

3.1 Unless otherwise specified in the procurement document, one specimen shall be tested from each sample unit.

4. APPARATUS

4.1 Sewing machine. A high-speed double needle, 1/4-inch (6.35 mm) gauge sewing machine, making stitch type 401 of FED-STD-751. The machine shall be fitted with a well polished flat surface presser foot. An appropriate plastic or plastic coated presser foot may also be used to reduce drag on the cloth being tested. The sewing machine shall be set to operate at 4500 ± 100 stitches per minute and to sew 12 ± 1 stitches per inch ($5 \pm 1/2$ stitches/cm).

4.2 Needles and thread. Two needles shall be used in the test. The needles shall chrome-plated, regular set, round cloth point standard eye size. Needles with ball points or cutting points shall not be used. Ball eye needles may be used provided that the measurement across the eye meets the requirement specified in the end procurement document. The size of the needle and of the thread shall be specified in the procurement document, based upon the size of the needle and sewing thread which will be used in the production of sewn items from the material under test.

FED. TEST METHOD STD. NO. 191A

METHOD 5404

5. PROCEDURE

5.1 Unless otherwise specified in the procurement document, all tests shall be performed on material conditioned as specified in Section 4.

5.2 The tension of the sewing thread in both needles and both loopers shall be adjusted to properly form stitch type 401 of FED-STD-751 without puckering. The distribution of thread in the stitch by length shall be 40 ± 5 percent needle thread and 60 ± 5 percent looper thread.

5.3 The pressure on the presser foot shall be adjusted to provide proper feed ratio of cloth to needle speed, so that 12 ± 1 stitches per inch ($5 \pm 1/2$ stitches/cm) are maintained throughout the stitching cycle, and so that puckering, pleating, and shifting or creeping of material is avoided.

5.4 The adjustments and settings of the sewing machine shall be tested on a trial specimen by the procedure described in 5.5. This specimen shall be prepared from cloth similar to the one being tested and which is known not to cause encrustation. This preliminary test will prevent thread breaks or skip stitching attributable to improper adjustments or settings, and the use of thread of inferior sewing quality when sewing the test specimen.

5.5 The 4 strips of cloth comprising the test specimen shall be superimposed one on the other, face up, with the ends falling 2 inches (51 mm) behind each other. The strips shall be stitched together along the left side approximately 1/2 inch (13 mm) from the edge, beginning 2 inches (51 mm) from the end of the top strip (see figure 5404, step 1). The strips shall be brought under the table board of the sewing machine and the corresponding ends shall be butted to form a continuous 4-layer band (see figure 5404, step 2). The sawing over the butted ends shall be continued in helical form, progressing toward the other edge of the specimen, with each double row of stitching at least, 1/4 inch (6 mm) from the preceding row. Do not sew over previously sewn areas.

5.5.1 Stitching shall be continued until skip stitching or thread rupture occurs because of needle encrustation, or until 20 or other specified number of yarns have been sewn.

5.5.2 When skip stitching or thread breakage occurs because of needle encrustation, the failing needle or needles shall be removed and the length of satisfactory stitching and behavior of the right- and left-hand needles shall be reported separately. A new needle or needles shall be inserted and stitching shall be resumed. This procedure shall be continued for the 20 or other specified yards of stitching.

FED. TEST METHOD STD. NO. 191A

METHOD 5404

5.6 Thread breaks or skip stitching caused by other than needle encrustation shall be disregarded.

5.7 Specimens having a significant amount of puckering, pleating, or creeping attributable to faulty technique shall be discarded and another specimen taken.

5.8 Evaluation. The specimen shall be examined visually and unless otherwise specified in the procurement document, the sewability shall be evaluated qualitatively. When specified in the procurement document, the quantitative determination shall be made.

5.8.1 Qualitative. The specimen shall be examined for presence or absence of skip stitching and thread breakage after the full 20 or other specified number of yards have been sewn. The degree of needle encrustation shall be ranked as "slight", "moderate", or "heavy".

5.8.2 Quantitative. When the needles on one side of the sewing machine give more trouble than those on the other, the sewing ability of this side shall be evaluated. The evaluation shall be based upon either of the following:

5.8.2.1 The average number of needles (or pairs of needles) required to sew the 20 or other specified number of yards (m).

5.8.2.2 The average distance in yards (m) sewn per needle (or pairs of needles), obtained by dividing the total distance sewn by the number of needles (or pairs of needles) required to sew that distance.

6. REPORT

6.1 Unless otherwise specified in the procurement document, the sewability of the sample unit shall be reported qualitatively. The presence or absence of skip stitching and thread breakage and the degree of needle encrustation shall be reported.

6.2 When specified in the procurement document, the sewability of the sample unit shall be reported quantitatively. The average number of needles required to sew the specified distance or the average distance sewn per needle (or pair of needles) shall be reported.

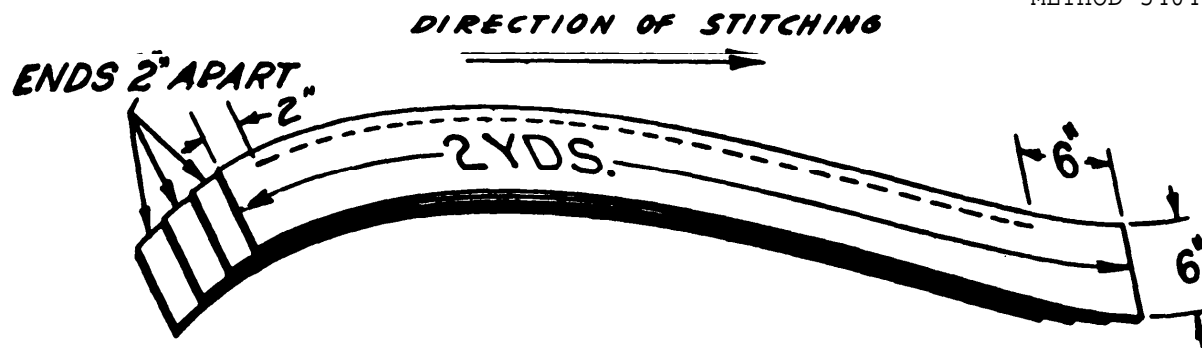

STEP 1

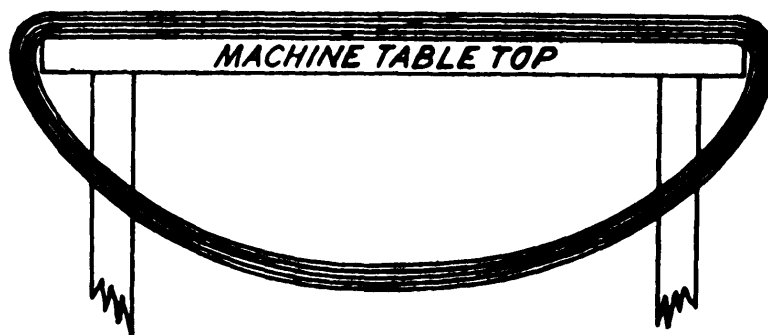

STEP 2

*SPECIMEN FOR
NEEDLE ENCRUSTATION TEST*

METHOD 5410
July 20, 1978

SLIPPAGE RESISTANCE OF YARNS IN CLOTH;

YARN DISTORTION METHOD

1. SCOPE

1.1 This method is intended for determining the resistance to slipping or shifting of one system of yarns over the other in cloth. Surface friction is applied under a specified load and the resultant yarn distortion is measured to obtain the resistance to yarn slippage of the warp or filling yarns. This method is especially applicable to nettings, marquisettes, gauzes, and other open-weave cloths.

2. TEST SPECIMEN

2.1 Unless otherwise specified in the procurement document, the specimen shall be a rectangle of cloth 4 by 8 inches (102 by 203 mm), cut from the unhandled portion of the cloth, with the long dimension parallel to the filling for warp tests and parallel to the warp for filling tests. No 2 specimens for warp tests shall contain the warp yarns, nor shall any 2 specimens for the filling tests contain the same filling yarns. No selvage shall be included in the sample tested.

3. NUMBER OF DETERMINATIONS

3.1 Unless otherwise specified in the procurement document, three specimens shall be tested in each of the warp and filling directions for each sample unit.

4. APPARATUS (figure 5410A)

4.1 Yarn slippage resistance apparatus. A pair of cylindrical rubber friction drums, or grippers, mounted vertically on the tester in such a way that the specimen may be inserted between their two rounded contacting surfaces. Each drum shall be 3/4 inch (19 mm) in diameter and have a Shore durometer hardness of 55 to 60 (A scale). The lower drum shall be 2 inches (51 mm) in length, fastened to the platform of the apparatus, and capable of being rotated in the mounting frame between tests. The upper drum shall be 1 inch (25 mm) in length, have the same provisions for rotation as the lower one, and shall be so mounted that a total weight of 1 to 5 pounds (.45 to 2.27 kg) can be applied to the specimen by means of a lever arm and a movable weight (see 7.1).

4.2 A mounting frame, or bracket, capable of holding the specimen under uniform tension. The frame consists of a rectangle whose inside dimensions are 4 by 6 inches (102 by 152 mm). The 4-inch (102 mm) sides are rectangular screw clamps 3/8 inch (10 mm) in width, with the gripping surfaces suitably

METHOD 5410

grooved, taped, or otherwise designed to minimize slipping of the specimen in the clamps during the test. The frame, when placed in test position on the rails, shall be free to slide as a carriage in a plane perpendicular to the plane of the axes of the friction drums.

4.3 Hand-crank arrangement for a 1-inch (25 mm) reciprocating motion of the carriage. This device, or reciprocating arm, shall have a cam attachment which lifts the upper drum in the return motion.

4.4 Two sets of rails, fixed and spaced on the platform of the tester, for supporting the carriage.

4.5 Means for mounting the specimen in the frame under the tension of a 5-pound (2.27 kg) load. A suitable device consisting of a clamp and weight (figure 5410A) totalling 5 pounds (2.27 kg).

4.6 Scale graduated in 0.01 inch (.25 mm), dividers, and suitable magnifying device or optical comparator and measuring device or traveling microscope.

5. PROCEDURE

5.1 Unless otherwise specified in the procurement document, all tests shall be performed on material conditioned as specified in Section 4.

5.2 A yarn shall be pulled from the edge of the specimen in each of the warp and filling directions to aid in aligning the specimen in the brackets, or frame, of the tester.

5.3 The specimen shall be placed in the frame so that the warp and filling yarns are parallel to the sides of the frame. One 4-inch (102 mm) end of the specimen shall be clamped in one end of the frame. The 5-pound (2.27 kg) load shall then be applied across the opposite 4-inch (102 mm) width of the specimen and the second clamp securely tightened.

5.4 The upper friction drum shall be raised on its weighted lever and the frame placed between the drums, positioning it at the extreme end of its travel on the rails.

5.5 Unless otherwise specified in the procurement document, the weight of the upper friction drum shall be adjusted to provide a total force of 3 pounds (13.4 N) during the test.

5.6 Two rotations of the hand crank shall be made at a speed of approximately 30 rpm to slide the carriage back and forth over a distance of 1 inch (25 mm), causing the cloth to slip back and forth between the friction drums. The area of friction on the specimen shall be centrally located between the clamps, approximately 1/2 inch (13 mm) from one long edge of the specimen.

METHOD 5410

5.7 The carriage shall be transferred to the second pair of rails and the test repeated to cause another area of friction 1/2 inch (13 mm) from the other long edge of the specimen.

5.7.1 The rubbing surfaces of the friction drums shall be turned in their clamps, presenting a new surface after every 40 rubbing cycles. The jaws shall be replaced after 1 revolution in their clamps.

5.8 The carriage shall be removed from the rails, and the specimen carefully removed from the frame and taped without tension on a flat surface. A transparent film shall be placed over the specimen, care being taken not to distort the yarns.

5.9 The specimen shall be allowed to relax for 15 minutes after removal from the frame. The widest opening of each shift mark, or distorted yarn group, as illustrated by figure 5410A, shall be measured to the nearest 0.01 inch (0.25 mm) under magnification, using a pair of dividers and graduated scale, traveling microscope, or optical comparator.

5.10 Test results which show unshifted or nonaligned yarns, as illustrated by figure 5410B, shall be considered unmeasurable.

5.11 The average of the 2 strokes on each specimen shall be the slippage of the specimen.

6. REPORT

6.1 The yarn slippage resistance of the sample unit shall be the average of the results obtained from the specimens tested in each of the warp and filling directions and shall be reported to the nearest 0.01 inch (0.1 mm).

6.2 When a test result is considered unmeasurable, the nature of such resistance (distortion), and the direction in which it occurred shall be reported.

6.3 Each individual value used to calculate the average shall also be reported.

7. NOTES

7.1 A yarn slippage resistance apparatus of the type described in this method may be purchased from the United States Testing Company, 1415 Park Avenue, Hoboken, NJ 07030.

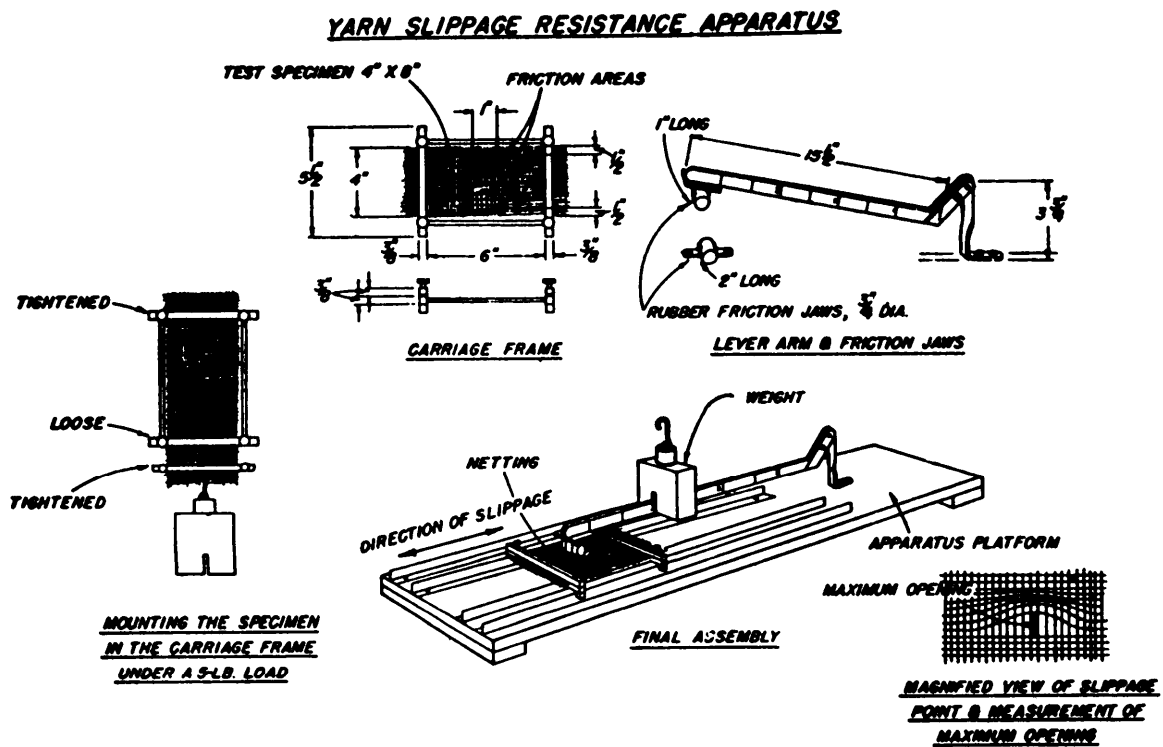
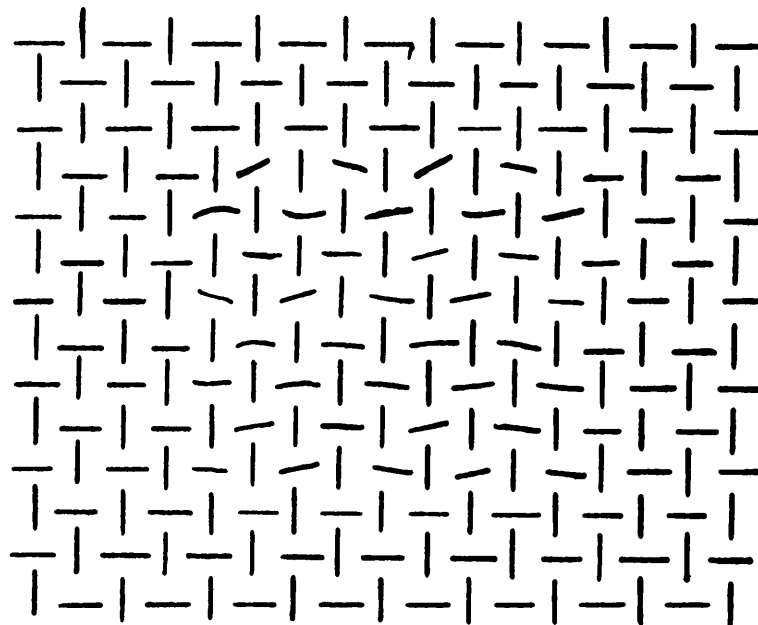
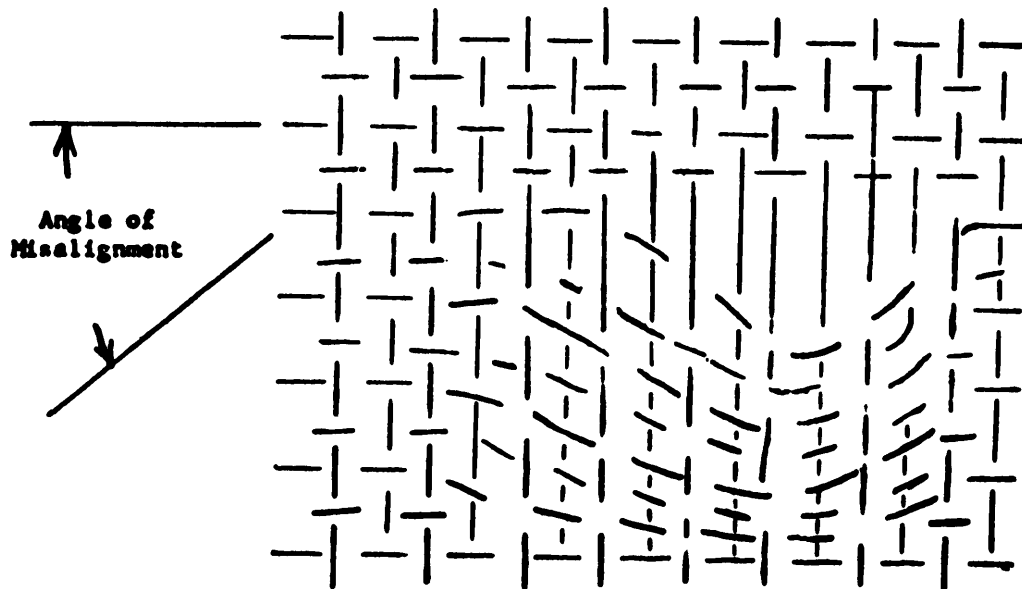

FIGURE 5410A



(a) Unshifted - Nonmeasurable
(May contain friction marks)



(b) - Unaligned - Nonmeasurable

FIGURE 5410B - Unmeasurable shift openings.

METHOD 5420
July 20, 1978

SLIPPAGE RESISTANCE OF YARNS IN CLOTH; SEAM METHOD

1. SCOPE

1.1 This method is intended for determining the resistance to slippage of one system of yarn over the other at and parallel to the seams in woven cloth, caused by stress resulting from the application of load perpendicular to the seam direction. The resistance to slippage is the pounds pull (across a seam) per inch (25 mm) of width necessary to produce a specified elongation, in inches (mm), in excess of the normal stretch of the cloth under the same load. This method is more severe, and suitable for testing closely woven cloths, than Method 5410. It does not apply to slippage resulting from yarn distortion, or to slippage caused by fraying or ravening.

2. TEST SPECIMEN

2.1 Unless otherwise specified in the procurement document, the test specimen shall be a rectangle of cloth, 4 by 14 inches (102 by 356 mm), cut from the long dimension parallel to the filling for the warp tests and parallel to the warp for filling tests. No selvage shall be included in the specimen tested. No two specimens for warp tests shall contain the same warp yarns, nor shall any two specimens for filling tests contain the same filling yarns.

3. NUMBER OF DETERMINATIONS

3.1 Unless otherwise specified in the procurement document, five specimens from each of the warp and filling directions shall be tested from each sample unit.

3.2 When tests in the direction of least resistance only are specified, five specimens shall be tested from each sample unit.

4. APPARATUS AND METHOD CITED

4.1 Apparatus.

4.1.1 Tensile testing machine. A tensile testing machine and autographic recording device-as described in Method 5100. The machine shall be of such capacity that the maximum load required to break the specimen shall be not greater than 85 percent or less than 15 percent of the rated capacity.

4.1.2 Needles and thread. Unless otherwise specified in the procurement document, the needle shall be 0.030 ± 0.001 inch (0.762 ± 0.025 mm) across the blade of the eye and the thread shall be cotton, type ICl, ticket No. 00, 3-ply of V-T-276; Thread, Cotton.

FED. TEST METHOD STD. NO. 191A

METHOD 5420

4.1.3 Sewing machine. A sewing machine capable of producing a 301 stitch type of FED-STD-751.

4.1.4 Dividers.

4.2 Method cited.

Method 5100, Strength and Elongation, Breaking of Woven Cloth; Grab Method.

5. PROCEDURE

5.1 Preparation of specimen. The specimen shall be prepared as follows:

5.1.1 Standard seam. Unless otherwise specified in the procurement document, the specimen shall be folded back upon itself, 4 inches (102 mm) from one end, care being taken to have the fold parallel to the crosswise yarns. A seam shall be machine sewn, 1/2 inch (13 mm) from the fold and parallel to the crosswise yarns, using uniform tension. 14 ± 1 stitches per inch ($5\text{-}1/2 \pm 1/2$ stitches/cm) shall be used in the seam. The tension on the sewing thread shall be adjusted to properly form stitch type 301 of FED-STD-751 without puckering.

5.1.2 Previously prepared seam. When specified in the procurement document, specimens may be taken from existing seams in a garment or sewn article. The specimens may be a seam assembly cut 4 inches (102 mm) wide and 13 inches (330 mm) long and having the seam located 3-1/2 inches (89 mm) from one end. The specimen shall be selected with the short dimension parallel (or as parallel as possible) to the seam, and the long dimension perpendicular to the seam and in the direction of least resistance as determined by preliminary tests. The direction of yarns perpendicular to the seam shall be recorded.

5.1.3 Determination of direction of least resistance. A preliminary test performed by following the procedures of 5.3 to 5.5 on one specimen with the seam in the direction of the warp and another with the seam in the direction of the filling will indicate the direction of least resistance.

5.2 Unless otherwise specified in the procurement document, all tests shall be performed on material conditioned as specified in Section 4.

5.3 The distance between the clamps shall be set at 3 inches (76 mm). One cloth load-elongation determination and one load-elongation curve for cloth-plus-seam shall be made on each specimen. The two curves shall be made on the same chart to provide means for determining one test result as described below. In all tests, the specimen shall be aligned squarely in the clamps with the crosswise yarns at right angles, and the lengthwise yarns parallel to the direction of application of load. Care shall be taken to grip the same lengthwise yarns of the same specimen in both clamps in both tests.

FED. TEST METHOD STD. NO. 191A

METHOD 5420

5.4 Load-elongation curve for cloth. The end of the specimen farthest from the seam shall be placed in the jaws of the machine with the long dimension parallel to the direction of application of load. The specimen shall be placed in the jaws under the 6-ounce (170 g) load. The recording pen shall be set at the zero-point on the chart and the load-elongation curve autographically recorded up to the point of failure of the cloth or up to 50 pounds (23 kg).

5.5 Load-elongation curve for cloth-plus-seam. The specimen shall be cut along the fold adjacent to the seam. The untested portion of the specimen shall be clamped with the seam midway between the upper and lower clamps. The recording pen shall be set on the same zero-point used for the load-elongation curve for the cloth. The load-elongation curve shall be recorded autographically to the point of failure of the cloth or up to 50 pounds (23 kg).

5.6 Slippage charts obtained will resemble Figure 5420.

5.7 Calculation of results.

5.7.1 Unless otherwise specified in the procurement document, resistance to slippage shall be the pounds per inch (g/mm) of cloth width required to produce an elongation of 1/4 inch (6 mm) in excess of the normal stretch of the cloth.

5.7.2 If the load-elongation curve is serrated, it shall be smoothed out by drawing a line through the tops of the serrations. A pair of dividers shall be set at points B and C of Figure 5420, where the two curves cross the 1-pound (453 g) ordinate. This distance between the curves is called the "compensation". The dividers shall then be placed on a scale and opened an additioned distance corresponding to the specified 1/4 inch (6 mm) or other specified slippage, correcting this distance for the ratio of magnification of the chart.

5.7.3 With the dividers set as in 5.7.2 and with one point on the cloth curve, proceed up this curve until the other point rests on the load-elongation curve for the "cloth-plus-seam", with both points resting on the same ordinate. The total load in pounds at this position shall be recorded. The 1-pound (453 g) "compensation" shall be subtracted from this total load. The remainder shall be the resistance to slippage, or the force required to produce a 1/4 inch (6 mm) slippage per 1 inch (25 mm) of cloth when jaws measuring 1 inch (25 mm) perpendicular to the direction of the application of load are used. When this jaw measurement is 2 inches (51 mm), 2 pounds (907 g) shall be used for "compensation" and the final result divided by two.

6. REPORT

6.1 Unless otherwise specified in the procurement document, the yarn slippage of the sample unit shall be the average of the results obtained from the specimens tested in each of the warp and filling directions, and shall be reported separately to the nearest 0.5 pound (to the nearest 1 N).

METHOD 5420

6.1.1 When the direction of least resistance is specified, the average of the results obtained from the specimens tested in that direction shall be reported to the nearest 0.5 pound (to the nearest 1 N).

6.2 Each individual value used to calculate the average shall also be reported.

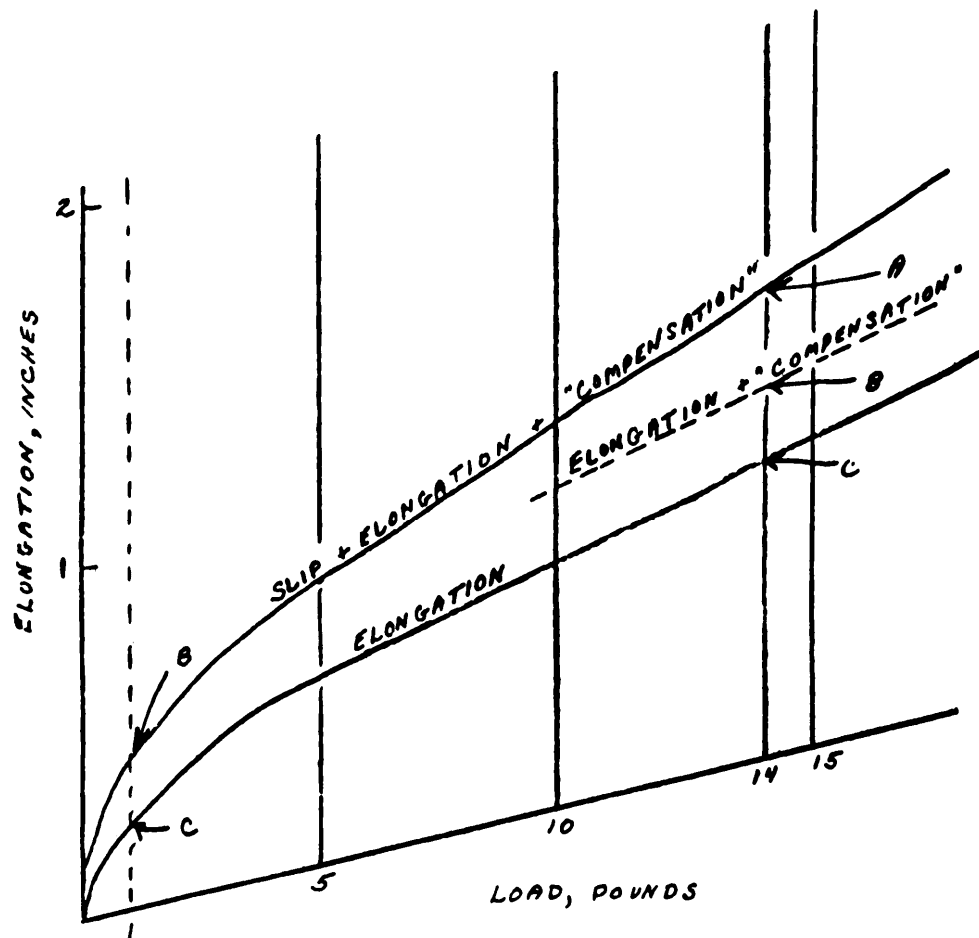

SLIPPAGE CHART

A to B = Distance equivalent to 1/2 inch slip (ratio of chart distance to slip distance is 2:1; 1/4 inch when ratio of chart distance to slip distance is 1:1;

B to C = "Compensation" at 1 lb.

Slippage of cloth was at 14 lb. reading, or $14 - 1 = 13$ lb. per inch, corrected

FIGURE 5420

PERMEABILITY TO AIR; CLOTH; CALIBRATED ORIFICE METHOD

1. SCOPE

1.1 This method is intended for determining the air permeability of cloth. It is recommended for cloths as thin and light as parachute cloth to those as thick and heavy as blanket material. It may be used for cloth having an air permeability from 0.1 to 5502.0 cubic feet of air per minute per square foot (0.05 to 2795 cm³/sec/cm²) of cloth. The pressure drop across the cloth may also be varied within wide limits.

2. TEST SPECIMEN

2.1 The specimen shall be a square of cloth a minimum of 7 inches by 7 inches (178 mm by 178 mm) (see 7.2).

3. NUMBER OF DETERMINATIONS

3.1 Unless otherwise specified in the procurement document, five specimens shall be tested from each sample unit.

4. APPARATUS (See figs. 5450A and 5450B)

4.1 Air permeability testing machine. Any air permeability instrument which has two oil or oil water manometers (see 7.1), one partly inclined, for measuring the pressure drop across the cloth under test; the other for measuring the pressure drop across the orifice. The partly inclined manometer shall be graduated to read pressure in inches (mm) of water.

4.1.1 The partly inclined manometer shall have one end left open to the atmosphere and the other end attached to the cylinder between the air orifice and the specimen. The vertical manometer shall have one end attached to the cylinder between the orifice and the fan, and the other end to the cylinder between the orifice and the cloth.

4.2 Leveling screws and a micrometer plunger for setting the meniscus of the inclined manometer to "zero" when no air is being drawn through the cloth.

4.3 An oil reservoir for each manometer. The reservoir for the vertical manometer shall have a large area in comparison to the cross sectional area of the manometer.

4.4 Nine air orifices having the following nominal diameters in millimeters: 1.0, 1.4, 2.0, 3.0, 4.0, 6.0, 8.0, 11.0 and 16.0.

METHOD 5450

4.5 Cylindrical chamber approximately $16 \pm 1/2$ inches (406 mm \pm 13 mm) long and 6 inches (152 mm) in diameter containing a partition near the middle equipped to hold the air orifice. A cloth orifice over which the specimen is placed shall be at one end of the cylinder, and a motor-driven suction fan shall be at the other end of the cylinder.

4.6 A 3 pound (1.36 kg) beveled ring and clamp, attached if desired, so as to hold the specimen under tension and in a smooth condition against the cloth orifice.

4.7 Rheostat(s) used for varying the speed of the motor which drives the suction fan.

4.8 A removable attachment to vary the cloth orifice to allow readings from 0.1 to 5502.0 cubic feet of air per minute per square foot (0.05 to 2795 $\text{cm}^3/\text{m}/\text{cm}^2$) of cloth.

5. PROCEDURE

5.1 Unless otherwise specified in the procurement document, the pressure drop across the cloth shall be 0.5 inch (13 mm) of water.

5.2 The specimen, which shall not have been previously folded, creased, or in any manner deformed, shall be placed across the cloth orifice and the beveled 3 pound (1.36 kg) ring and clamp shall be placed over the cloth to hold the specimen under a slight tension and in a smooth condition. Air shall be drawn through the cloth and through the calibrated orifice by means of the suction fan.

5.2.1 The appropriate size of orifice to use for a cloth, whose approximate air permeability is not known, is determined by a trial run.

5.3 The pressure drop across the cloth, measured on the inclined manometer, shall be adjusted to the required pressure drop by adjusting the speed of the suction fan motor. The pressure drop across the orifice shall then be noted on the vertical manometer. The volume of air passing through the cloth shall be calculated from this value and the calibration of orifice. Due to variations in machines available, calculation of air volumes shall be performed in accordance with manufacturer's instructions.

5.3.1 The pressure drop indicated by the vertical manometer shall not be less than 3 inches (76 mm) nor more than 26 inches (660 mm).

6. REPORT

6.1 Unless otherwise specified in the procurement document, the air permeability of the specimen shall be expressed in cubic feet of air per minute per square foot ($\text{cm}^3/\text{sec}/\text{cm}^2$) of cloth at a pressure drop of 0.5 inch (13 mm) of water across the specimen.

METHOD 5450

6.2 The air permeability of the sample unit shall be the average of the results obtained from the five specimens tested and shall be reported to the nearest 0.1 cubic foot (to the nearest 0.001 m³).

6.3 Each individual value used to calculate the average shall also be reported.

7. NOTES

7.1 The oil used is "Meriam red oil" and can be obtained from the Meriam Instrument Co., 10978 Madison Avenue, Cleveland, OH 44102. An air permeability apparatus of the type described may be purchased from the Frazier Precision Instrument Company, 210 Oakmont Avenue, Gaithersburg, MD 20760.

7.2 A 0.0412 square foot (0.0038 m²) area of cloth through which the air passes for approximately 900 cubic feet (25.5 m³) when using a 2-3/4 inch (70 mm) diameter opening and a 0.0077 square foot (0.0007 m²) area for 5502 cubic feet (156 m³) when using a 1-3/16 inch (30 mm) diameter opening have been found satisfactory for the described uses.

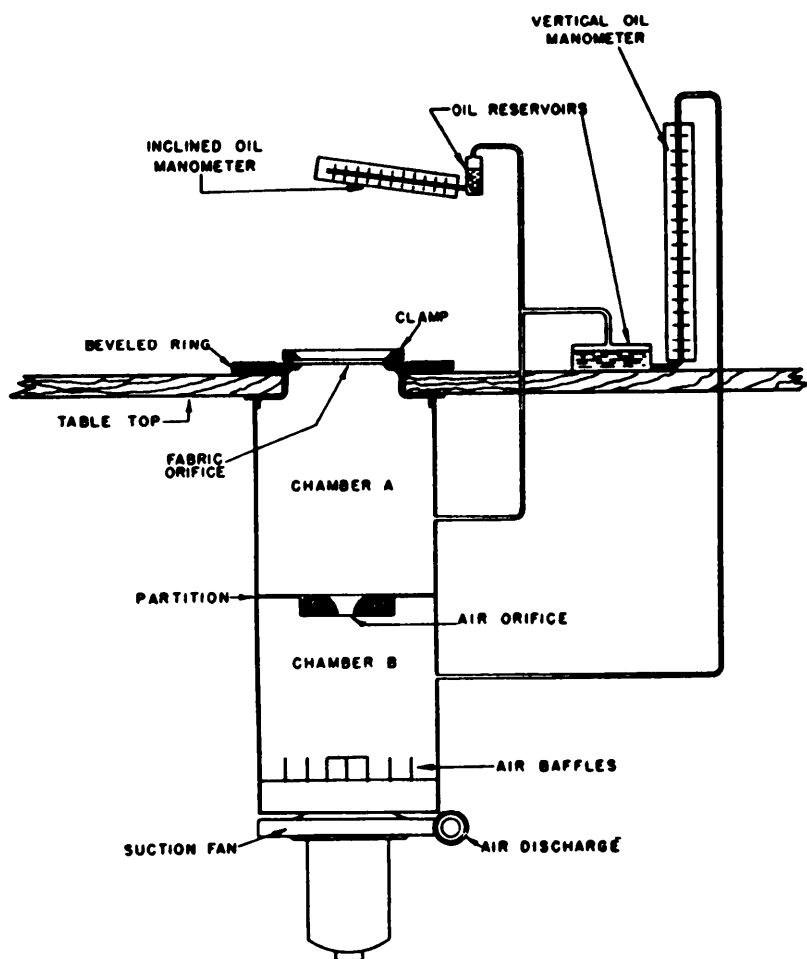

FIGURE 5450A - Schematic diagram of air-permeability instrument.

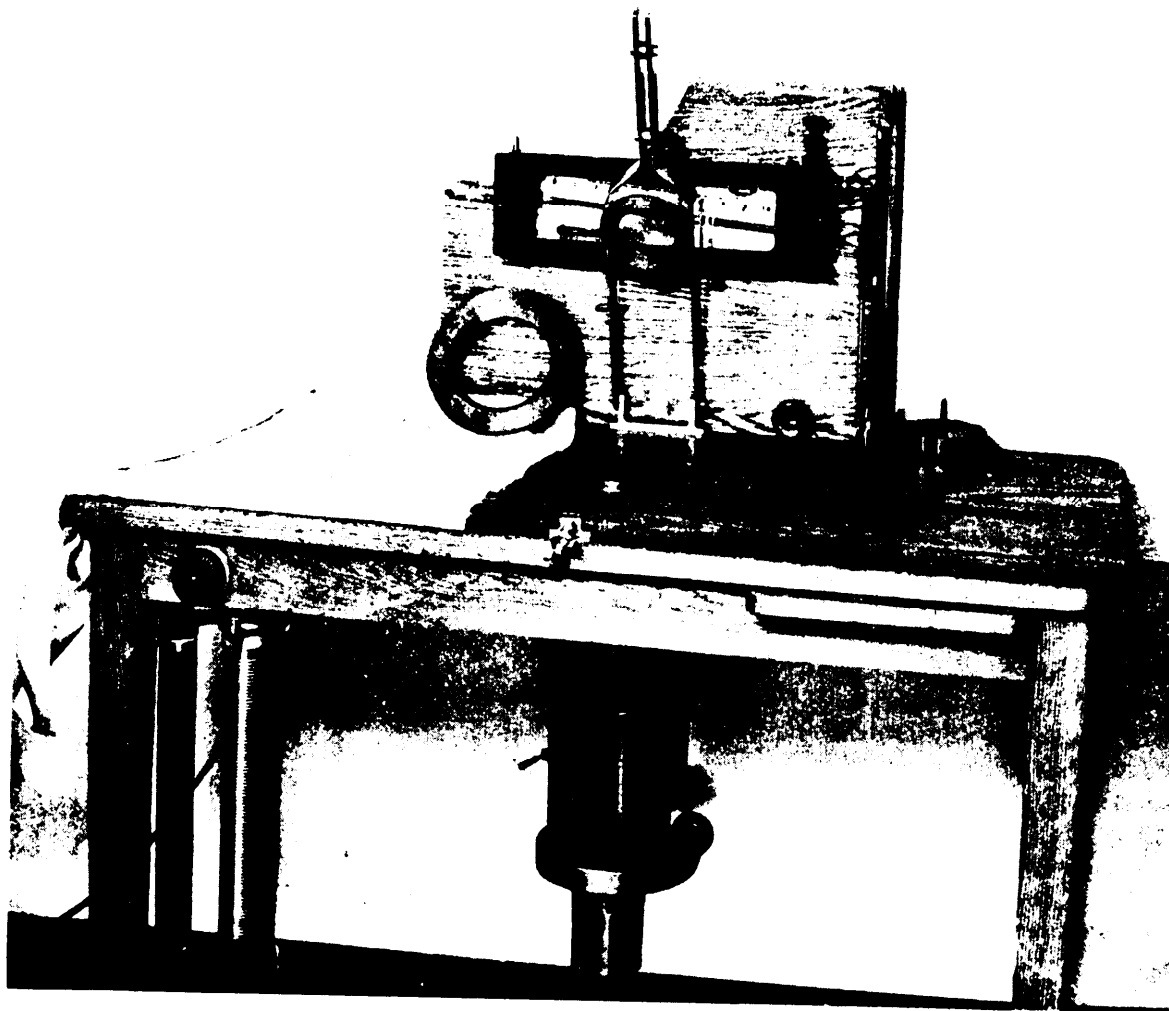

FIGURE 5450B

PERMEABILITY TO AIR; CLOTH; FALLING CYLINDER METHOD

1. SCOPE

1.1 This method is intended for determining the air permeability of cloth. It is recommended for testing closely woven, light weight, and thin fabrics which offer a great deal of resistance to the flow of air.

2. TEST SPECIMEN

2.1 The specimen shall be a square of cloth 4 inches by 4 inches (102 mm by 102 mm). The actual area of the specimen through which the air is forced shall be 0.10 square inch (64.5 mm²).

30 NUMBER OF DETERMINATIONS

3.1 Unless otherwise specified in the procurement document, 10 specimens shall be tested from each sample unit.

4. APPARATUS (See figure 5452)

4.1 Air permeability testing machine. The air permeability test machine shall consist of two cylinders, the outer one of which shall be 9-1/2 inches (241 mm) high and 3 inches (76 mm) in diameter, and the inner cylinder 9-5/8 inches (244 mm) high and 2-7/8 inches (73 mm) in diameter (see 7.1).

4.1.1 The inner cylinder furnishes the air pressure which shall have an airtight top and shall weigh 5 ounces (142 g). The upper of its cylindrical surface shall have six division marks, each division representing a volume of 50 cm³.

4.2 The two orifice plates shall be coaxially clamped together by means of the capstan clamp. The clamp plates shall be self-aligning so as to prevent the leakage of air along the surface of the specimen. The upper orifice shall be the end of a tube which extends upward through the closed bottom of the outer cylinder which contains oil. The upper end of the orifice tube shall be open and extend above the oil in the outer cylinder. The lower plate shall be fastened to a supporting stand in such a manner as to permit free flow of air through the orifice. The inner cylinder which furnishes the pressure shall move freely, and the lower end shall extend into the oil in the outer cylinder in such a manner as to furnish an airtight seal for all positions of the inner cylinder.

METHOD 5452

4.3 Clamping device. Clamping device for holding the Inner cylinder in a raised position.

4.4 Capstan screw clamping device.

4.5 Oil. Oil, for use in the outer cylinder, having a Saybolt viscosity of 60 to 70 seconds at a temperature of 100°F (38°C).

4.6 Stopwatch or other timing device which will indicate the time to one-fifth of a second.

5. PROCEDURE

5.1 The inner cylinder shall be raised to its highest position and the specimen clamped securely between the orifice plates. The inner cylinder shall be released from its highest position. The downward movement of the cylinder increases the pressure of the trapped air in the upper part of the cylinder which in turn is transmitted through the open end tube to the specimen between the orifice plates, thus causing air to pass through the specimen.

5.2 The rate at which air passes through the specimen is the air permeability of the specimen and shall be obtained by determining the time necessary for the division marks on the inner cylinder to pass the upper edge of the outer cylinder.

5.3 Unless otherwise specified, the air permeability of the specimen shall be expressed as the time in seconds for 300 cm³ of air to pass through the cloth.

6. REPORT

6.1 The air permeability of the sample unit shall be the average of the results obtained from the specimens tested and shall be reported to the nearest second.

6.2 Each individual value used to calculate the average shall also be reported.

7. NOTES

7.1 An air permeability apparatus of the type described in this method may be obtained from W. and L. E. Gurley, 514 Fulton Street, Troy, NY 12181.

AIR PERMEABILITY-FALLING CYLINDER METHOD

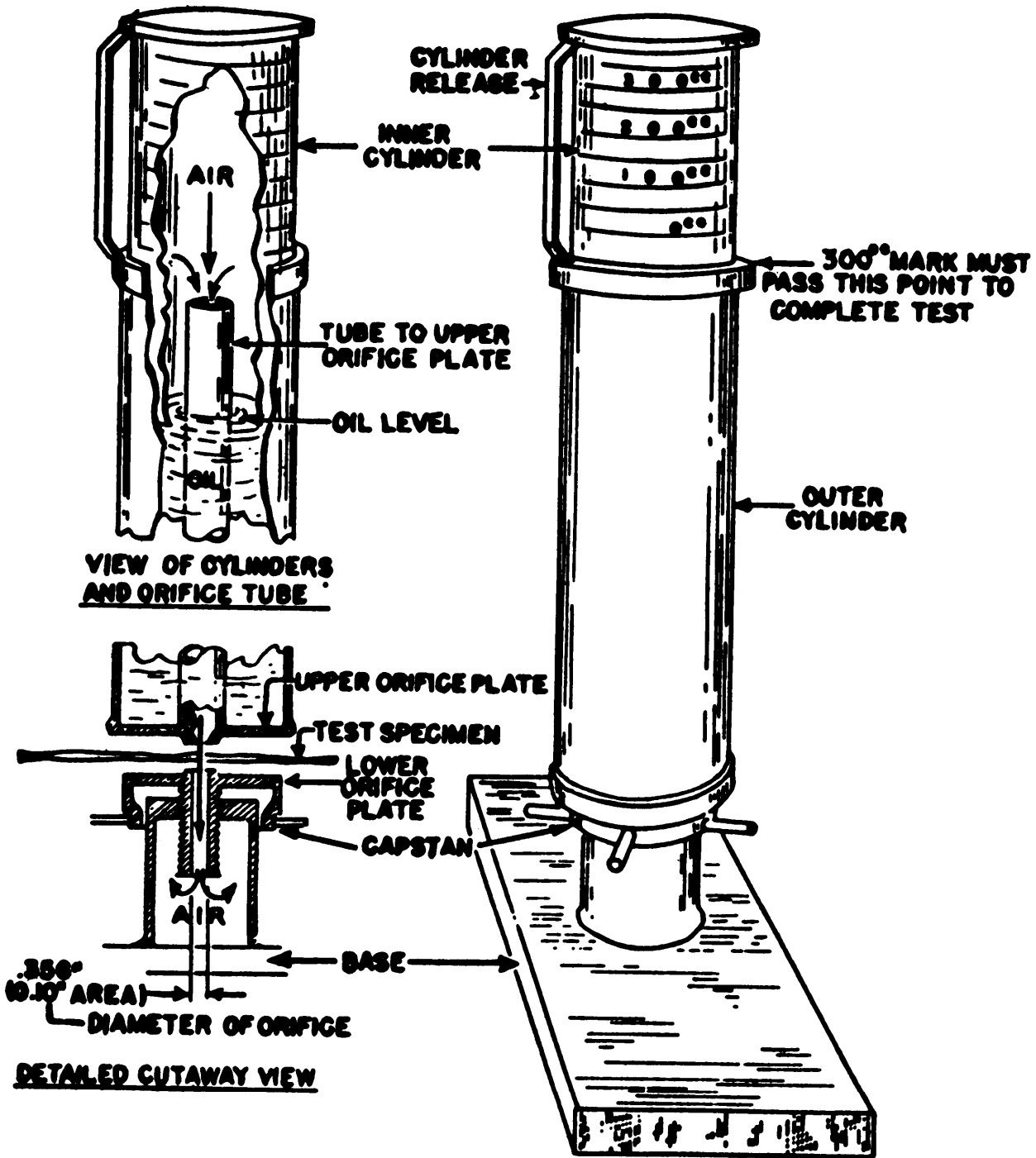

FIGURE 5452

WATER RESISTANCE OF CLOTH; DYNAMIC ABSORPTION METHOD

1. SCOPE

1.1 This method is intended for determining the amount of water absorbed by cloth when subjected to dynamic conditions.

2. TEST SPECIMEN

2.1 The specimen shall be composed of five square pieces of the finished cloth, each 8 by 8 inches (203 by 203 mm), cut on a 45-degree bias with the loose corner yarns removed (see 7.2).

3. NUMBER OF DETERMINATIONS

3.1 Unless otherwise specified in the procurement document, two specimens (10 pieces) shall be tested from each sample unit.

4. APPARATUS

4.1 Tumble jar. A tumble jar (see figure 5500A), cylindrical in shape with approximate dimensions being 12 inches (305 mm) in height and 6 inches (152 mm) in diameter (or between opposite flat faces) with a capacity of approximately 1.6 gallons (6 L). The jar shall be of glass, corrosion-resistant metal or chemical stoneware. The jar shall be mounted in a vertical position in such a manner that it can be rotated around the horizontal axis passing through the center of the jar. Means shall be provided for rotating the jar around the axis at a speed of 55 ± 2 revolutions per minute. The jar shall be clean and thoroughly rinsed so that it is free from soap, detergent, and wetting agents (see 7.1).

4.2 Wringer. A wringer (see figure 5500B), of the household type equipped with smooth rubber squeeze rolls 2-1/8 to 2-1/2 inches (54 to 64 mm) in diameter and not less than 11 inches (279 mm) nor more than 16 inches (406 mm) in length. The rubber rolls shall have a Shore durometer hardness of 70 to 80 (A scale). The load exerted on the specimen shall be applied uniformly by means of a dead weight, attached to the top roller. The total load of the roller, means of attaching the weight and the weight itself shall be 60 pounds (27.2 kg). The rolls shall be power driven at such a speed that the specimen shall pass through the rolls at the rate of 1 inch (25 mm) per second.

4.3 Balance. A laboratory balance capable of weighing accurately to 0.01 g.

4.4 Blotting paper. The blotting paper dimensions shall be 10 inches (254 mm) square (see 7.3).

METHOD 5500

4.5 Container. Tared glass or plastic container.

5. PROCEDURE

5.1 Unless otherwise specified in the procurement document, the rotation of the jar shall be a minimum of 20 minutes.

5.2 Original weight of the specimen. The five pieces constituting one specimen shall be conditioned, then rolled together and weighed to the nearest 0.01 g. This is the "Weight of the original conditioned specimen" and in the calculation of results is designated as "O". Each individual piece of the specimens shall be marked to maintain the individual identities. Two liters of distilled water at a temperature of $80^{\circ} \pm 2^{\circ}\text{F}$ ($27^{\circ} \pm 1^{\circ}\text{C}$) shall be placed in the tumble jar, and the specimen shall be added, one piece at a time. Two specimens (10 pieces) may be tested at the same time providing each specimen is taken from a different sample unit. If only one specimen is tested, a specimen of similar material with respect to weight shall be run as ballast with the specimen undergoing test. The cloth in the jar during any run shall be the equivalent of two specimens.

5.3 The jar and contents shall be rotated at the rate of 55 ± 2 revolutions per minute for the time specified in the procurement document.

5.4 At the end of the required running time, one piece shall be run through the wringer with one edge parallel to the length of the rollers.

5.5 The same piece shall immediately be placed smoothly between two sheets of blotting paper. The piece of cloth and blotters shall be passed through the rollers of the wringer by the procedure described in 5.4. The piece of cloth shall be left between the two blotters until all five pieces of the specimen (between sheets of blotting paper) have been passed between the rollers.

5.6 Final weight of the specimen. Each of the remaining pieces shall be treated as described in 5.4 and 5.5. The five pieces shall then be removed from the blotting paper, rolled together and weighed in a tared closed container to the nearest 0.01 g. This is the "Final weight of the specimen" and in the calculation of results is designated as "F"

5.6.1 Care shall be taken at all times to keep evaporation of moisture from specimen to a minimum.

5.7 Calculation of results. The dynamic absorption shall be calculated as follows:

METHOD 5500

$$\text{Dynamic absorption percent} = \frac{F - O}{O} \times 100$$

Where: O = Original weight of the specimen.

F = Final weight of the specimen.

6. REPORT

6.1 The dynamic absorption of the sample unit shall be the average of the results obtained from the two specimens (10 pieces) tested and shall be reported to the nearest 0.1 percent.

6.2 Each individual value used to calculate the average shall also be reported.

7. NOTES

7.1 A tumble jar suitable for conducting this test may be obtained from Andrew Technical Supply Co., 2540 Eastwood Ave., Evanston, IL 60204.

7.2 If the material of test is subject to excessive raveling, a drop of liquid latex or rubber cement shall be spread on the yarns at each corner to prevent raveling. Care shall be exercised in the selection of the latex or rubber cement to insure impurities are not present which will affect results.

7.3 The blotting paper is available from:

James River Paper Company
P.O. Box 2218
Richmond, VA 23217

DYNAMIC ABSORPTION TEST

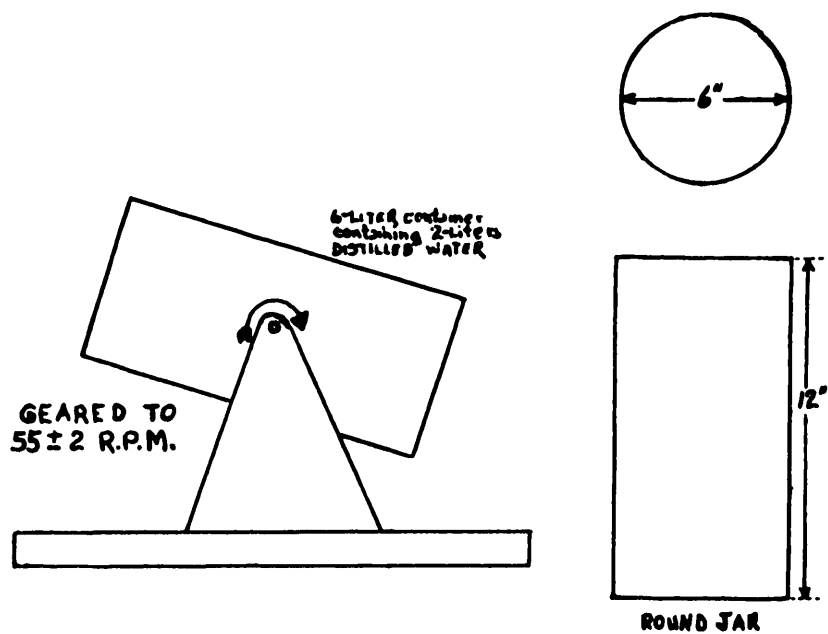

FIGURE 5500A - TUMBLE JAR

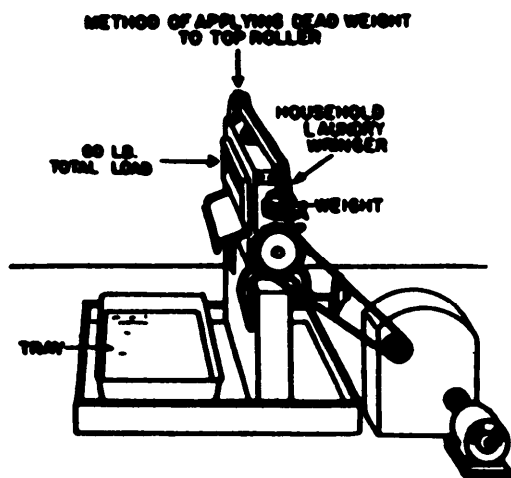

FIGURE 5500B - WRINGER

METHOD 5502
July 20, 1978

WATER RESISTANCE OF CLOTH; IMMERSION ABSORPTION METHOD

1. SCOPE

1.1 This method is intended for determining the amount of water absorbed by cloth when subjected to static conditions. This method is not as severe as Method 5500.

2. TEST SPECIMEN

2.1 Standard. Unless otherwise specified in the procurement document, the specimen shall be a square of cloth 3 inches by 3 inches (76 by 76 mm). Departure from the required specimen size shall be permitted when necessary so that appreciably heavy or light cloths shall fall within the weight range of not less than 1 g nor more than 4 g. Changes in size shall be permitted only in multiples of 6 inches (152 mm).

2.2 Lightweight cloths. The size of the specimen for lightweight cloth shall be larger than for heavyweight cloth (6 inches by 6 inches (152 by 152 mm) for mosquito netting) and should be specified in the procurement document.

2.3 Narrow cloths. The dimensions of narrow cloth specimens shall be as follows:

<u>Type of Material</u>	<u>Specimen width, inches (mm) (measured to nearest 1/8 inch (1 mm))</u>	<u>Length required (inches) (mm)</u>
Narrow cloth	1/4 to 3/8 (6 to 10 mm)	24 (610 mm)
Narrow cloth	1/2 to 7/8 (13 to 22 mm)	18 (457 mm)
Narrow cloth	1 to 1-3/8 (25 to 35 mm)	12 (305 mm)
Narrow cloth	1-1/2 to 3 (38 to 76 mm)	6 (152 mm)

3. NUMBER OF DETERMINATIONS

3.1 Unless otherwise specified in the procurement document, five specimens shall be tested from each sample unit.

4. APPARATUS

4.1 Blotting paper. The standard blotting paper dimensions shall be a minimum of 4 inches by 4 inches (102 by 102 mm) (see 7.1). For lightweight cloths and narrow cloths, the blotting paper shall be approximately one inch (25 mm) greater than the length and width of the specimen.

METHOD 5502

4.2 Wringer. A wringer (see figure 5502) of a household type equipped with smooth rubber squeeze rolls 2-1/8 to 2-1/2 inches (54 to 64 mm) in diameter and not less than 11 inches (279 mm) nor more than 16 inches (406 mm) in length. The rubber rolls shall have a Shore durometer hardness of 70 to 80 (A scale). The load exerted on the specimen shall be uniformly applied by means of a dead weight, attached to the top roller. The total load of the roller, means of attaching the weight, and the weight itself shall be 60 pounds (27.2 kg). The rolls shall be power driven at such a speed that the specimen shall pass through the rolls at the rate of 1 inch (25 mm) per second.

4.3 Sinker. A sinker for keeping the specimen submerged, shall consist of a rigid inverted L-shaped metal hook of noncorrosive metal fastened to a weight. The sinker shall be sufficiently heavy to sink to the bottom of the tank when attached to the specimen. (normally a weight of 3.5 to 5.5 ounces (100 to 150 g) is adequate.) In testing narrow cloth, the horizontal end of the sinker hook shall be of sufficient length so that the portions of the specimens attached thereon may spread out to permit full contact with the water.

4.4 Tank. A tank of such size as to permit a 2-inch (51 mm) hydrostatic head of water above the top of the specimens undergoing test.

4.5 Balance. A laboratory balance capable of weighing accurately to 0.05 g.

4.6 Distilled water.

5. PROCEDURE

5.1 Unless otherwise specified in the procurement document, the time of immersion shall be 20 ± 1 minutes.

5.2 Original conditioned weight of the specimen. The specimen shall be conditioned and weighed to the nearest 0.05 g. This is the "Original conditioned weight of the specimen" and is designated as "0". Each specimen shall be marked prior to weighing to maintain the individual identities.

5.3 When a narrow cloth is under test, the specimen shall be folded fanwise to a 6 inch (152 mm) length.

5.4 The specimen shall be attached to the sinker and immersed for the required time in a tank of distilled water at a temperature of $27^{\circ} \pm 1.0^{\circ}\text{C}$ ($80^{\circ} \pm 2^{\circ}\text{F}$). The depth of the water shall be so regulated that, with the sinker resting on the bottom of the tank, the top of the specimen held in a vertical position shall be immersed under a 2-inch (51 mm) head of water.

5.5 At the end of the immersion period, the specimen shall be removed from the bath and sinker detached. The specimen shall be spread out and immediately placed between two blotters and passed once through the wringer at the rate of 1 inch (25 mm) per second. One edge of the specimen shall be parallel to the length of the rollers.

METHOD 5502

5.5.1 When narrow cloth is being passed through the wringer, the longitudinal direction of the material shall be perpendicular to the axis of the rolls.

5.5.2 In the case of napped cloths of all fibers and in the case of all cloth of 100 percent wool (napped or unnapped) the specimen shall be squeezed once through a wringer without blotters and then once with blotters.

5.6 Final weight of the specimen. After squeezing through the wringer, the specimens shall be weighed immediately in a tared container to the nearest 0.05 g. This is the "Final weight of the specimen" and is designated as "F". Care shall be taken to keep evaporation of moisture from the specimen to a minimum.

5.7 Calculation of results. The immersion absorption shall be calculated as follows:

$$\text{Immersion absorption, percent} = \frac{F - O}{O} \times 100$$

Where:

F = Final weight of the specimen.

O = Original conditioned weight of the specimen.

6. REPORT

6.1 The immersion absorption of the sample unit shall be the average of the results obtained from the five specimens tested and shall be reported to the nearest 0.1 percent.

6.2 Each individual value used to calculate the average shall also be reported.

7. NOTES

7.1 The blotting paper is available from:

James River Paper Company
P.O. BOX 2218
Richmond, VA 23217

IMMERSION ABSORPTION TEST

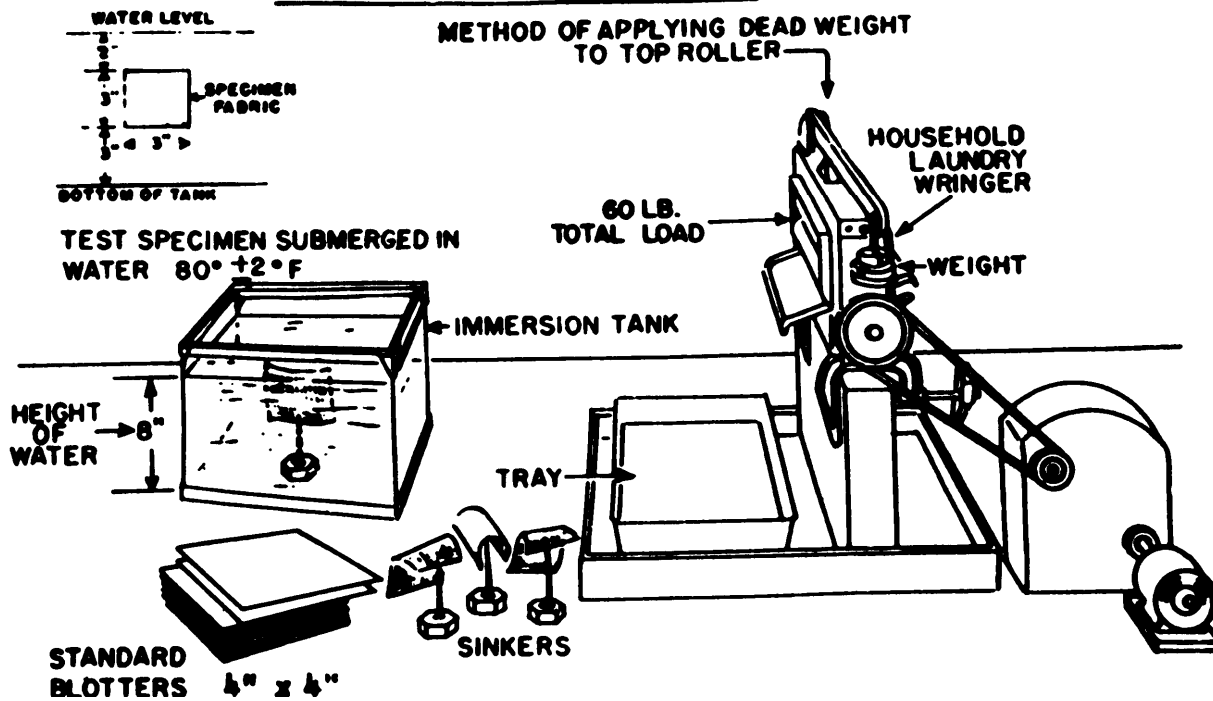

FIGURE 5502

METHOD 5504
July 20, 1978

WATER RESISTANCE OF COATED CLOTH; SPRAY ABSORPTION METHOD

1. SCOPE

1.1 This method is intended for determining the resistance to water absorption of the uncoated or lightly coated side of cloth with a water-proof coating.

2. TEST SPECIMEN

2.1 The specimen shall be a square of finished cloth 8 inches by 8 inches (203 by 203 mm).

3. NUMBER OF DETERMINATIONS

3.1 Unless otherwise specified in the procurement document, three specimens shall be tested from each sample unit.

4. APPARATUS AND METHOD CITED

4.1 Apparatus.

4.1.1 Apparatus as described in Method 5526 except that the distance from the bottom of the nozzle to the center of the mounted specimen shall be 24 inches (610 mm).

4.1.2 Blotting paper. The blotting paper dimensions shall be 10 inches by 10 inches (254 by 254 mm) (see 7.1).

4.1.3 Balance. A laboratory balance capable of weighing the specimen to an accuracy of 0.05 g.

4.1.4 Metal roller. Metal roller approximately 4-1/2 inches (114 mm) long and weighing 2-1/4 pounds (1 kg).

4.2 Distilled water.

4.3 Method cited.

Method 5526, Water Resistance of Cloth with Hydrophobic Finish;
Spray Method.

FED. TEST METHOD STD. NO. 191A

METHOD 5504

5. PROCEDURE

5.1 Unless otherwise specified in the procurement document, the conditioned specimen shall be securely mounted, with the lightly coated or uncoated side up, in metal embroidery hoops with sufficient tension to insure a uniformly smooth surface.

5.2 Unless otherwise specified in the procurement document, the direction of the flow of water down the specimen shall coincide with the warpwise direction of the specimen as placed on the stand.

5.3 The mounted specimen shall be placed on the block with the center of the specimen directly beneath the center of the nozzle and the plane of the surface of the specimen at a 45° angle with the horizontal.

5.4 A 500 ml. volume of distilled water at a temperature of 27° ± 1.0°C (80° ± 2°F) shall be poured quickly into the funnel and allowed to spray onto the specimen.

5.5 The following operations shall then be executed as rapidly as possible:

5.5.1 The specimen shall be removed from the hoops and placed between sheets of blotting paper on a flat horizontal surface. The metal roller shall be rolled quickly forward and back one time over the paper without application of any pressure other than the weight of the roller.

5.5.2 Weight of wet specimen. A square 4 inches by 4 inches (102 by 102 mm) shall be cut out of the center of the wet portion of the specimen and weighed to the nearest 0.05 g. This is the "Weight of the wet 4-inch (102 mm) square specimen" and is designated as "W". Not more than 30 seconds shall elapse between the time the water has ceased flowing through the spray nozzle and the start of the weighing.

5.5.3 Weighing of conditioned specimen. The same 4-inch (102 mm) square shall be left in the conditioning room until it has dried and reached moisture equilibrium with the surrounding standard atmosphere for textiles and again weighed. This is the "Weight of the conditioned 4-inch (102 mm) square specimen" and is designated as "O".

5.6 Calculation of results. The water absorbed shall be calculated as follows:

$$\text{Water absorption, percent} = \frac{W - O}{O} \times 100$$

METHOD 5504

Where: W = Weight of the wet 4-inch (102 mm) square specimen.

O = Weight of the conditioned 4-inch (102 mm) square specimen.

6. REPORT

6.1 Water absorption of the sample unit shall be the average of the results obtained from the specimens tested and shall be reported to the nearest 0.1 percent.

6.2 Each individual value used to calculate the average shall also be reported.

7. NOTES

7.1 The blotting paper is available from:

James River Paper Company
P.O. Box 2218
Richmond, VA 23217

METHOD 5506
July 20, 1978

DRY CLEANING TEST, ACCELERATED; FOR LABELS

1. SCOPE

1.1 This method is intended for determining the fastness of the markings of labels to dry cleaning.

2. TEST SPECIMEN

2.1 Labels 2 inches by 4 inches (51 by 102 mm) and larger. The test specimen shall be a number of rectangles, each measuring approximately 2 inches by 4 inches (51 by 102 mm) weighing a total of 4.5 ± 0.5 g.

2.2 Labels smaller than 2 inches by 4 inches (51 by 102 mm). Labels shall be lapped and stitched together with all printing in the same plane to give a total area of approximately 2 inches by 4 Inches (51 by 102 mm).

2.3 Each test specimen shall be pinked along each edge (see 7.1).

3. NUMBER OF DETERMINATIONS

3.1 Unless otherwise specified in the procurement document, one specimen shall be tested from each sample unit.

4. APPARATUS AND REAGENTS

4.1 Apparatus.

4.1.1 Launder-Ometer. Launder-Ometer or similar machine having a metal adapter in which tightly capped stainless steel cylindrical containers 8 inches (203 mm) in length by 3-1/2 inches (89 mm) in diameter are held lying along the direction of motion of the rotating shaft, with the shaft rotating at a speed of 40 to 45 rpm. Each container shall be equipped with a sealing device having solvent resistant rings. An equal number of stainless steel containers shall be fastened on opposite sides of the rotating shaft in order to maintain balanced and smooth rotation during the test. The Launder-Ometer shall be maintained at a temperature of $80^{\circ} \pm 2^{\circ}\text{F}$ ($27^{\circ} \pm 1^{\circ}\text{C}$) (see 7.2).

4.1.2 Stainless steel balls. One hundred stainless steel balls, 1/4-inch (6 mm) in diameter, per container.

4.1.3 Pressing equipment.

FED. TEST METHOD STD. NO. 191A

METHOD 5506

4.1.3.1 Steam pressing. Flat bed press at a temperature of 275° to 300°F (135° to 149°C) having hot head or polished metal top for flat cloths or cloth covered press for rough crepes.

4.1.3.2 Hand iron. A hand iron weighing approximately 6 pounds (2.7 kg) capable of maintaining temperatures between 275° to 300°F (135° to 149°C).

4.2 Reagents.

4.2.1 Dry cleaning solvent. Dry cleaning solvent (Stoddard Solvent) conforming to the requirements of P-D-680, Dry Cleaning Solvent.

4.2.2 Perchloroethylene. Dry cleaning solvent, perchloroethylene (tetrachloroethylene) conforming to the requirements of O-T-236, Tetrachloroethylene (Perchloroethylene); Technical-Grade (see 7.3).

4.2.3 Dry cleaning soap. The dry cleaning soap shall be made by dissolving 56 g of caustic potash (KOH) in 100 ml of water. This solution shall then be poured slowly with constant stirring into a mixture of 240 g of oleic acid, 400 ml of Stoddard solvent, and 100 ml of tertiary butyl alcohol or an equal quantity of butyl cellosolve.

5. PROCEDURE

5.1 When a standard sample has been established for fastness to dry cleaning, Method A shall be used for evaluating the fastness of the labels. When no standard sample has been established, Method B shall be used for evaluating the fastness of the labels.

5.2 When a standard or comparison sample has been established, the standard or comparison sample shall be tested under the same conditions as the specimen undergoing the test.

5.3 The specimen shall be placed in the stainless steel container with 150 ml of perchloroethylene, 1 ml of dry cleaning soap and 100 stainless steel balls. The jar shall be sealed, clamped in the Launder-Ometer and run at 80° ± 2°F (27° ± 1°C) for ten minutes at which time the solvent shall be drained.

5.4 One hundred and fifty ml of Stoddard solvent and 1 ml of dry cleaning soap shall then be placed in the jar with the specimen and the 100 stainless steel balls. The Launder-Ometer shall then be run at 80° ± 2°F (27° ± 1°C) for 10 minutes at which time the solvent shall be drained.

5.5 One hundred and fifty ml of perchloroethylene without dry cleaning soap shall then be placed in the jar with the specimen and the 100 stainless steel balls. The Launder-ometer shall then be run at 80° ± 2°F (27° ± 1°C) for 10 minutes at which time the solvent shall be drained. The specimen shall then be removed and blotted thoroughly between paper towels or blotters or extracted to remove excess solvent and then air dried.

METHOD 5506

5.6 Pressing. When dry, the specimen shall be pressed in one of the following ways:

5.6.1 Hand pressing. The specimen shall be covered with a clean white muslin cloth weighing 4 to 4-1/2 ounces per square yard (135 to 153 g/m²), previously saturated with water and wrung out to retain approximately 75 percent moisture by weight. The damp muslin cloth shall be ironed until dry.

5.6.2 Steam pressing. The head of the machine shall be lowered and held in contact with the specimen. Steam shall be admitted from the back of the press during lowering for a period of 5 to 10 seconds. The head of the press shall then be maintained in a lowered position until the specimen is dry.

5.7 Evaluation. Change in definition of print shall be considered in rating fastness of labels to dry cleaning. The evaluation shall be performed under artificial daylight having a color temperature of 7500 kelvin.

5.7.1 Method A, standard sample. When a standard or comparison sample has been established, the test specimen shall be compared with the standard or comparison sample and rated as follows:

Pass: Equal to or superior to the standard sample.
Fail: Inferior to the standard sample.

5.7.2 Method B, no standard sample. When no standard sample for comparison has been established, the test specimen shall be rated as to definition of print and legibility of print at a distance of 18 inches (457 mm) as follows:

Excellent: Practically no change in legibility or definition or print.
Good: Readily legible without difficulty.
Fair: Legible without need for deciphering.
Poor: Not readily legible, requiring deciphering.

6. REPORT

6.1 Standard sample. When a standard sample has been established, fastness to dry cleaning shall be reported as "pass" or "fail".

6.2 No standard sample. When no standard sample has been established, fastness to dry cleaning shall be reported as "pass" or "fail". When failure is reported, the severest departure (i.e. the actual rating "fair" or "poor"), of the change of the test specimen, shall be distinguished and reported.

METHOD 5506

7. NOTES

7.1 If the material for test is subject to excessive raveling, a thin ribbon of a latex acrylic adhesive shall be applied to each pinked edge. The following adhesive has been found satisfactory for the described use:

Vulcanol AL-1005-S
Alto Chemical Corporation
Trenton Avenue and William Street
Philadelphia, PA 19134

7.2 A Launder-Ometer of the type described in this method may be obtained from Atlas Electric Devices Company, 4114 North Ravenswood Avenue, Chicago, IL 60613.

7.3 Perchloroethylene is toxic by inhalation by prolonged or repeated contact with the skin or mucous membrane, or when ingested by mouth. The liquid can cause injuries to the eyes. However, with proper precautions it can be handled safely.

METHOD 5508
July 20, 1978

DRY CLEANING SOLVENT RESISTANCE OF CLOTH WITH
WATER-RESISTANT FINISH; TUMBLE JAR METHOD

1. SCOPE

1.1 This method is intended for determining the resistance, of cloth with a water-resistant finish, to dry cleaning solvent (Stoddard) using a tumble jar.

2. TEST SPECIMEN

2.1 The specimen shall be a square of cloth 8 inches by 8 inches (203 mm by 203 mm).

3. NUMBER OF DETERMINATIONS

3.1 Unless otherwise specified in the procurement document, three specimens shall be tested from each sample unit.

4. APPARATUS, REAGENT, AND METHOD CITED

4.1 Apparatus.

4.1.1 Tumble jar. A tumble jar (as shown in figure 5500A), cylindrical in shape with approximate dimensions being 12 inches (305 mm) in height and 6 inches (152 mm) in diameter (or between opposite flat faces) and with a capacity of approximately 1.6 gallons (6 L). The jar shall be of glass, corrosion-resistant metal or chemical stoneware. The jar shall be mounted in a vertical position in such a manner that it can be rotated around the horizontal axis passing through the center of the jar. Means shall be provided for rotating the jar around this axis at a speed of 55 ± 2 revolutions per minute. The jar shall be clean and thoroughly rinsed so that it is free from soap, detergent, and wetting agents (see 7.1)

4.1.2 Extractor. A centrifugal extractor of the laundry-type with a perforated basket, approximately 11 inches (279 mm) deep by 17 inches (432 mm) in diameter, with an operating speed of approximately 1500 revolutions per minute.

4.1.3 Circulating-air oven. A Circulating-air oven, thermostatically controlled and capable of maintaining the required temperature within a tolerance of $\pm 5^{\circ}\text{F}$ ($\pm 3^{\circ}\text{C}$).

4.1.4 Weights. Weight of approximately 50 pounds (23 kg) for cold pressing the specimen.

METHOD 5508

4.1.5 Ballast. Ballast composed of pieces of materials of the same size and similar to the specimen in weight.

4.2 Reagent.

4.2.1 Dry cleaning solvent. Dry cleaning solvent (Stoddard solvent) conforming to the requirements of P-D-680, Dry Cleaning Solvent.

4.3 Methods cited.

Method 5526, Water Resistance of Cloth with Hydrophobic Finish;
Spray Method.

Method 5528, Water Resistance of Coated Cloth; Spray Method.

5. PROCEDURE

5.1 Unless otherwise specified in the procurement document, the tumble jar shall be rotated for 60 minutes.

5.2 The specimen and about fourteen pieces of ballast shall be placed in the tumble jar with 0.5 gallons (2 L) of new Stoddard solvent at a temperature of $80^{\circ} \pm 5^{\circ}\text{F}$ ($27^{\circ} \pm 3^{\circ}\text{C}$) and the jar rotated for the required period.

5.3 The specimen shall then be removed, placed in a clean, dry laundry net (or equivalent) and centrifugally extracted for 5 to 7 minutes. After extraction, the specimen shall be dried at a temperature of $160^{\circ} \pm 5^{\circ}\text{F}$ ($71^{\circ} \pm 3^{\circ}\text{C}$) for 60 minutes in the circulating-air oven. Clean, dry cloth shall be used to protect the specimen from dirt or screening marks during drying.

5.4 The above operation shall be repeated on each specimen taken from each sample unit. However, specimens taken from other sample units of similar weight may be tested simultaneously by substituting specimens for a like number of ballast pieces. The total number of pieces including specimens and ballast pieces shall not exceed 15.

5.5 The dry specimen shall be cold pressed by placing a large flat weight of approximately 50 lbs. (23 kg) on a maximum of 15 cloth thicknesses, for a minimum of 1 hour prior to conditioning for the water resistance tests.

5.6 The water resistance of the dry-cleaned specimen shall be determined by Method 5526 or 5528 or by any other method as specified in the procurement document. The same tests shall be conducted on the dry-cleaned specimen and on a specimen which has not been dry-cleaned for the purpose of comparison in determining the degree of water resistance of the dry-cleaned cloth.

METHOD 5508

5.7 Calculation of results. The results shall be calculated as described in the method of test used for determining water resistance.

6. REPORT

6.1 Unless otherwise specified in the procurement document, the results shall be reported as described in the method of test used for determining water resistance.

7. NOTES

7.1 A tumble jar suitable for conducting this test may be obtained from Andrew Technical Supply Co., 2540 Eastwood Avenue, Evanston, IL 60204.

DRY CLEANING SOLVENT RESISTANCE OF CLOTH WITH WATER-RESISTANT

FINISH; LAUNDER-OMETER METHOD

1. SCOPE

1.1 This method is intended for determining the resistance, of cloth with a water resistant finish, to dry cleaning solvent using a Launder-Ometer.

2. TEST SPECIMEN

2.1 The specimen shall be a square of cloth 8 inches by 8 inches (203 mm by 203 mm).

3. NUMBER OF DETERMINATIONS

3.1 Unless otherwise specified in the procurement document, three specimens shall be tested from each sample unit.

4. APPARATUS, REAGENTS AND METHODS CITED

4.1 Apparatus.

4.1.1 Launder-Ometer. Launder-Ometer or similar machine having a metal adapter in which tightly capped stainless steel cylindrical containers 5 inches (127 mm) in length by 3 inches (76 mm) in diameter are held lying along the direction of motion of the rotating shaft, with the shaft rotating at a speed of 40 to 45 rpm. Each container shall be equipped with a sealing device having solvent resistant rings. An equal number of stainless steel containers shall be fastened on opposite sides of the rotating shaft in order to maintain balanced and smooth rotation during the test. The Launder-Ometer shall be maintained at a temperature of $80^{\circ} \pm 5^{\circ}\text{F}$ ($27^{\circ} \pm 3^{\circ}\text{C}$) (see 7.1).

4.1.2 Pressing equipment. A flat-bed press measuring 24 inches (610 mm) by 50 inches (1270 mm) or larger. Any flat-bed press capable of pressing a specimen 22 inches (559 mm) square or a hand-iron weighing approximately 6 pounds (2.7 kg) may be used as an alternative. The flat press or iron shall be equipped with a temperature control to maintain the temperature between 275° and 300°F (135° and 149°C).

4.2 Reagents.

4.2.1 Dry cleaning solvent. Dry cleaning solvent (Stoddard solvent) conforming to the requirements of P-D-680, Dry Cleaning Solvent.

METHOD 5509

4.2.2 Perchloroethylene. Dry cleaning solvent, perchloroethylene (tetrachloroethylene) conforming to the requirements of O-T-236, Tetrachloroethylene (Perchloroethylene); Technical-Grade (see 7.2).

4.2.3 Detergent. Soap conforming to the requirements of P-S-1792, Soap, Laundry (Neutral and Built), Type I, Class 1. A stock solution of the soap may be prepared by dissolving 1 pound of chip soap in 1 gallon of hot water (0.45 kg in 4 L). When cooled, this forms a thick homogeneous jelly which may be used as required.

4.3 Methods cited.

Method 5526, Water Resistance of Cloth with Hydrophobic Finish; Spray Method.

Method 5528, Water Resistance of Coated Cloth, Spray Method.

5. PROCEDURE

5.1 Unless otherwise specified, the Launder-Ometer shall be rotated for a period of 25 minutes for each operation at a temperature of $80^{\circ} \pm 5^{\circ}\text{F}$ ($27^{\circ} \pm 3^{\circ}\text{C}$).

5.2 The specimen shall be placed in the jar with 200 ml of fresh Stoddard solvent to which has been added 1 ml of the dry cleaning soap, 4.2.3. The jar shall be placed in the Launder-Ometer which shall be started and operated for the required period of time at the required temperature.

5.3 At the end of this period, the liquid in the jar shall be replaced with 200 ml of fresh, clean Stoddard solvent (no soap added), and the jar returned to the Launder-Ometer which shall be run for the required period of time.

5.4 At the end of the second period of operation, the Stoddard solvent shall be replaced with 300 ml of fresh, clean perchloroethylene (no soap added) and the jar returned to the Launder-Ometer which shall again be operated for the required period of time.

5.5 At the end of the third period of exposure, the specimen shall be removed from the jar, the surplus solvent removed by any convenient means which will not distort the cloth, and allowed to dry at room temperature.

5.6 The specimen shall be rinsed twice in the Launder-Ometer for a period of 5 minutes in distilled water at a temperature of $80^{\circ} \pm 5^{\circ}\text{F}$ ($27^{\circ} \pm 3^{\circ}\text{C}$), using the same volume as used for the preceding treatments. The excess moisture shall be removed from the specimen by any convenient means which will not distort the cloth. The specimen shall then be dried at room temperature.

METHOD 5509

5.7 The dried specimen shall be conditioned in the standard atmosphere for 4 hours and then shall be pressed either with a flat-bed press or hand-iron. The head of the press or the hand-iron shall be maintained at a temperature of 275° to 300°F (135° to 149°C) during the pressing operation. When a hand-iron is used, the iron shall not be slid back and forth on the specimen, but simply pressed down upon it in a manner simulating the action of the flat-bed press.

5.7.1 The water resistance of the specimen shall be determined by Method 5526 or 5528 or any other method as specified in the procurement document.

The same tests shall be conducted on the dry-cleaned specimen and on a specimen which has not been dry cleaned for the purpose of comparison in determining the degree of water resistance of the dry-cleaned cloth.

5.8 Calculation of results. The results shall be calculated as described in the method of test used for determining the water resistance.

6. REPORT

6.1 The results shall be reported as described in the method of test used for determining water resistance.

7. NOTES

7.1 A Launder-Ometer of the type described in this method may be obtained from Atlas Electric Devices Company, 4114 North Ravenswood Avenue, Chicago, IL 60613.

7.2 Perchloroethylene is toxic by inhalation, by prolonged or repeated contact with the skin or mucous membrane, or when ingested by mouth. The liquid can cause injuries to the eyes. However, with proper precautions it can be handled safely.

METHOD 5510
July 20, 1978

DRY CLEANING RESISTANCE OF CLOTH WITH WATER-RESISTANT

FINISH; ROTATING WHEEL METHOD

1. SCOPE

1.1 This method is intended for determining the resistance of cloth with a water resistant finish to dry-cleaning solvent (Stoddard) using a rotating wash wheel. This is an alternate to Method 5508 and is applicable where a larger production is required. This method is of about the same order of severity as Method 5508.

2. TEST SPECIMEN

2.1 The specimen shall consist of 3/4 yard (0.69 m) to 1-1/2 yard (1.37 m) length of the material, depending on the width of the cloth and the specimen size requirements of the subsequent water resistance tests.

3. NUMBER OF DETERMINATIONS

3.1 Unless otherwise specified in the procurement document, three specimens shall be tested from each sample unit.

4. APPARATUS, REAGENTS AND METHODS CITED

4.1 Apparatus.

4.1.1 Wash wheel (see 7.1). A cylindrical wash wheel of the reversing type shall be used. The wheel (cage) shall be 20 to 24 inches (508 to 610 mm) inside diameter and 20 to 24 inches (508 to 610 mm) inside length. There shall be 3 fins each approximately 3 inches (76 mm) wide extending the full length of the inside of the wheel. One fin shall be located every 120° around the inside diameter of the wheel. The wash wheel shall rotate at a speed of 30 ± 4 revolutions per minute making 5 to 10 revolutions before reversing. The water inlets shall be large enough to permit filling the wheel to an 8 inch (203 mm) level in less than 2 minutes, and the outlet shall be large enough to permit discharge of this same amount of water in less than 2 minutes. The machine shall be equipped with a pipe for injecting live steam that shall be capable of raising the temperature of water at an 8 inch (203 mm) level from 100° to 140°F (38° to 60°C) in less than 2 minutes.

4.1.2 Extractor. A centrifugal extractor of the laundry-type with a perforated basket, approximately 11 inches (279 mm) deep by 17 inches (432 mm) in diameter, with an operating speed of approximately 1500 revolutions per minute.

METHOD 5510

4.1.3 Circulating-air oven. Circulating-air oven, thermostatically controlled and capable of maintaining the required temperature within a tolerance of $\pm 5^{\circ}\text{F}$ ($\pm 3^{\circ}\text{C}$).

4.1.4 Ballast. Ballast composed of pieces of material of the same size and similar to the specimen in weight.

4.2. Reagent.

4.2.1 Dry cleaning solvent. Dry cleaning solvent (Stoddard solvent) conforming to the requirements of P-D-680, Dry Cleaning Solvent, Type I.

4.3 Methods cited.

Method 5526, Water Resistance of Cloth with Hydrophobic Finish;
Spray Method.

Method 5528, Water Resistance of Coated Cloth; Spray Method.

5. PROCEDURE

5.1 Unless otherwise specified in the procurement document, the wheel shall be rotated for 60 minutes.

5.2 Stoddard solvent at a temperature of $80^{\circ} \pm 5^{\circ}\text{F}$ ($27^{\circ} \pm 3^{\circ}\text{C}$) shall be poured into the wheel to a level of 4 inches (102 mm). The specimen and approximately a total of 12 yards (11 m) of ballast (pieces cut to size of specimen) shall then be placed in the wheel and the wheel rotated for the required period.

5.3 The specimen shall then be removed, placed in a clean, dry laundry net (or equivalent) and centrifugally extracted for 5 to 7 minutes. After extraction, the specimen shall be dried at $160^{\circ} \pm 5^{\circ}\text{F}$ ($71^{\circ} \pm 3^{\circ}\text{C}$) for 60 minutes in the circulating-air oven. Clean, dry cloth shall be used to protect the specimen from dirt or screening marks during drying.

5.4 The above operation shall be repeated for each specimen taken from each sample unit. However, specimens taken from other sample units of similar weight may be tested simultaneously by substituting specimens for a like number of ballast pieces including specimens and ballast pieces shall not exceed approximately 12 yards (11 m).

5.5 The water resistance of the dry-cleaned specimen shall be determined by Method 5526 or 5528 or by any other method as specified in the procurement document. The same tests shall be conducted on the dry-cleaned specimen and on a specimen which has not been dry cleaned for the purpose of comparison in determining the degree of water resistance of the dry-cleaned cloth.

METHOD 5510

5.6 Calculation of results. The results shall be calculated as described in the method of test used for determining water resistance.

6. REPORT

6.1 Unless otherwise specified in the procurement document, the results shall be reported as described in the method of test used for determining water resistance.

7. NOTES

7.1 A wash wheel of the type described in this method is available from:

Robert Ewing & Sons, Co.
P.O. Box 454
Troy, NY 12181

American Laundry Company
5050 Section Avenue
Cincinnati, OH 45212

WATER RESISTANCE OF COATED CLOTH; HIGH RANGE,
HYDROSTATIC PRESSURE METHOD

1. SCOPE

1.1 This method is intended for determining the resistance of coated cloth to the passage of water under high pressure.

2. TEST SPECIMEN

2.1 Unless otherwise specified in the procurement document, the specimen shall be a square of cloth 4 inches by 4 inches (102 by 102 mm).

3. NUMBER OF DETERMINATIONS

3.1 Unless otherwise specified in the procurement document, five specimens shall be tested from each sample unit.

4. APPARATUS

4.1 The standard testing machine shall be a hand or motor-driven hydrostatic tester, except in cases of dispute wherein the motor-driven hydrostatic tester shall be used. The specimen shall be held between the 2 annular plane clamping surfaces of the machine. Hydraulic pressure is applied to the underside of the clamped specimen.

4.1.1 The clamping surfaces may be concentric grooves not over 0.010 inch (0.25 mm) deep to prevent the specimen from slipping during the test.

4.1.2 The upper clamping surface shall have a circular opening 1.240 ± 0.010 inch (31.5 ± 0.25 mm) in diameter. The edge of the circular opening shall be rounded to a radius of not over $1/64$ inch (0.4 mm) to avoid cutting the specimen.

4.1.3 The lower clamping surface shall have an opening 1.240 ± 0.010 inch (31.5 ± 0.25 mm) in diameter. Concentric to it shall be a recession 0.094 ± 0.002 inch (2.4 ± 0.05 mm) in depth, with an inside diameter of 2.000 ± 0.010 inch (51 ± 0.25 mm), and an outside diameter of 2.375 ± 0.010 inch (60 ± 0.25 mm). A rubber gasket having a cross-sectional diameter of 0.187 ± 0.004 inch (4.75 ± 0.1 mm) shall be fitted tightly into the recession.

4.1.4 Means shall be provided for applying hydraulic pressure to the underside of the clamped specimen until leakage of the specimen occurs. This pressure shall be generated by means of a piston forcing water into the pressure chamber of the apparatus at the rate of 85 ± 5 ml per minute. The drive wheel shall rotate at approximately 60 revolutions per minute.

METHOD 5512

4.1.4.1 A pressure gage shall be of the Bourdon-Tube, maximum reading type, graduated in pounds per square inch (kPa) and accurate throughout the entire range of its scale to within a value equal to 1.0 percent of its maximum capacity. The capacity of this gage shall be such that the individual reading will not be less than 25 percent nor more than 75 percent of the total capacity of the gage.

5. PROCEDURE

5.1 The surface of the specimen to be exposed to water shall be as specified in the procurement document.

5.2 Prior to each determination, the piston shall be backed up to the normal starting position and the water level in the pressure chamber brought flush with the top of the rubber gasket so that no air pocket exists between the water surface and the specimens being tested. The specimen shall then be clamped tightly between the ring clamps to prevent horizontal leakage. The pressure shall then be applied at the specified rate.

5.3 The pressure in pounds per square inch (kPa) at the first appearance of water through the specimen shall be recorded.

6. REPORT

6.1 The hydrostatic resistance of the sample unit shall be the average of the results obtained from the specimens tested, and shall be reported to the nearest 1 pound per square inch (or nearest 10 kPa).

6.2 Each individual value used to calculate the average shall also be reported.

WATER RESISTANCE OF CLOTH; LOW RANGE,
HYDROSTATIC PRESSURE METHOD

1. SCOPE

1.1 This method is intended for determining the resistance of treated and untreated cloths to the passage of water under pressure. It is also applicable to the sealed seam area of fabricated coated cloth items as a measure of the efficiency of the seaming and related workmanship in the area of sealed seams.

2. TEST SPECIMEN

2.1 Unless otherwise specified in the procurement document, the test specimen shall be a square of cloth 8 inches by 8 inches (203 by 203 mm).

3. NUMBER OF DETERMINATIONS

3.1 Unless otherwise specified in the procurement document, five specimens shall be tested from each sample unit.

4. APPARATUS (See figure 5514 for a typical test apparatus)

4.1 Hydrostatic testing apparatus. The apparatus shall consist of an inverted conical well equipped with a coaxial ring clamp to fasten the cloth specimen over the well bottom. The apparatus shall introduce water at a temperature of $80^{\circ} \pm 5^{\circ}\text{F}$ ($27^{\circ} \pm 3^{\circ}\text{C}$) from above the specimen over a circular area 4.50 ± 0.05 inches (114 ± 1.3 mm) in diameter at the rate of 1.0 ± 0.1 cm of hydrostatic head per second, and the rubber tubing connecting the constant level device and the conical well shall have an inside diameter of $1/4$ to $3/8$ inch (6 to 10 mm). A mirror may be affixed below the specimen to enable the operator to ascertain penetration of the specimen by drops of water. A vent shall be provided for the air in the well to escape (see 7.1).

5. PROCEDURE

5.1 The surface of the specimen to be exposed to water shall be as specified in the procurement document.

5.2 The specimen shall be clamped over the orifice of the inverted conical well. Water shall be introduced into the well and the air above the cloth vented.

METHOD 5514

5.3 The hydrostatic head measured at the appearance of a drop or drops of water at three different places of the test area shall be recorded to the nearest 0.5 inch (13 mm). Drops of water penetrating the specimen at the clamped edge of the specimen or within 1/8 inch (3 mm) of this edge shall not be counted.

6. REPORT

6.1 The hydrostatic pressure resistance of the sample unit shall be the average of the results obtained from the specimens tested and shall be reported to the nearest 0.5 inch (13 mm) as required.

6.2 Each individual value used to calculate the average shall also be reported.

7. NOTES

7.1 A hydrostatic testing apparatus of the type described in this method may be obtained from the Richmond Machine Company, 3375 Richmond Street, Philadelphia, PA 19134, modified to include a constant level device as shown in figure 5514; and the Alfred Suter Company, 200 Fifth Avenue, New York, NY 10010.

HYDROSTATIC PRESSURE TEST

FIGURE 5514

METHOD 5516
July 20, 1978

WATER RESISTANCE OF CLOTH; WATER PERMEABILITY,
HYDROSTATIC PRESSURE METHOD

1. SCOPE

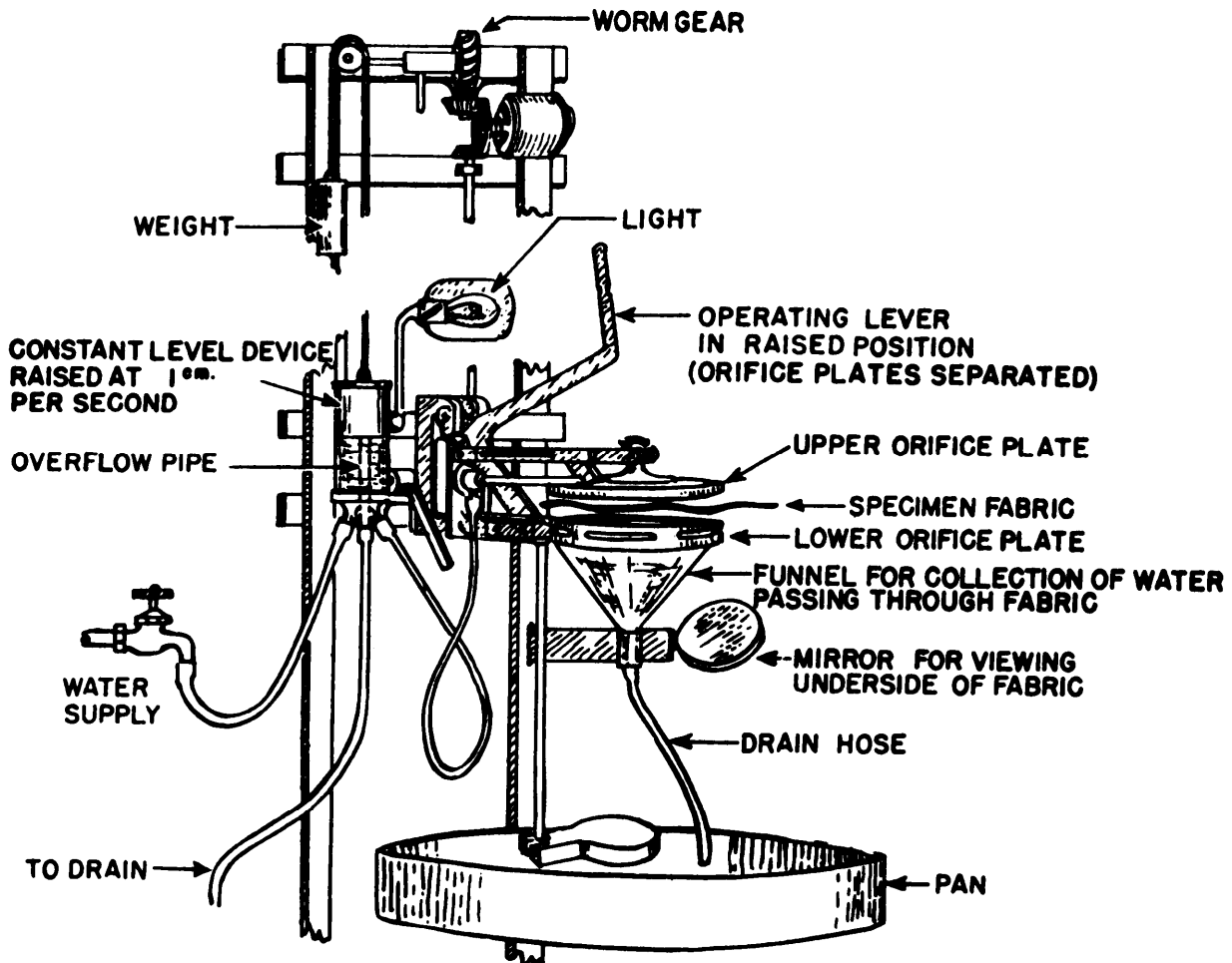
1.1 This method is intended for determining the water permeability of cloth under low hydrostatic pressure. It is especially applicable for the testing of medium and heavy weight cloths for tentage, tarpaulins, and water bags which are designed for contact with water without leakage. It is also applicable to the sealed seam area of fabricated coated cloth items as a measure of the efficiency of the seaming and related workmanship in the area of the sealed seams.

2. TEST SPECIMEN

2.1 The cloth or fabricated coated cloth item may be tested without cutting. If cut, the test specimen shall be a square of cloth at least 8 inches by 8 inches (203 by 203 mm).

3. NUMBER OF DETERMINATIONS

3.1 Unless otherwise specified in the procurement document, three specimens shall be tested from each sample unit.

4. APPARATUS (See figure 5516)

4.1 Hydrostatic testing apparatus. The apparatus shall consist of an inverted conical well equipped with a coaxial ring clamp to fasten the cloth specimen over the well bottom. The apparatus shall introduce water at a temperature of $80^{\circ} \pm 5^{\circ}\text{F}$ ($27^{\circ} \pm 3^{\circ}\text{C}$) from above the specimen over a circular area 4.50 ± 0.05 inches (114 ± 1.3 mm) in diameter and the rubber tubing connecting the constant level device and the conical well shall have an inside diameter of $1/4$ to $3/8$ inch (6 to 10 mm). A cut-off valve or other suitable device shall be provided at the water inlet of the upper orifice plate for keeping the water from the specimen until the desired head is reached. Means shall be provided for the air in the well to escape.

4.2 Funnel. A funnel shall be positioned below the exposed specimen area to collect water passing through the specimen when amount of water penetration is desired.

4.3 Mirror. A mirror may be affixed below the specimen to enable the operator to ascertain penetration of the specimen by drops of water when measure of appearance of drops is desired.

METHOD 5516

4.4 Timing device.

5. PROCEDURE

5.1 Unless otherwise specified in the procurement document, and as applicable, the heavier coated surface of the cloth shall be placed in contact with the water. The time of exposure in minutes, and hydrostatic head in inches or cm and criteria shall be as specified in the procurement document.

5.2 Measure of amount of water penetration. With the cut-off valve closed, the specimen shall be clamped on the inverted conical orifice and the water level adjusted to give the hydrostatic head required. The valve shall then be opened and the water passing through the specimen during the required period of time collected and the volume measured.

5.3 Measure of appearance of water drops in sealed seam areas of coated cloths. With the cut-off valve closed, the specimen shall be clamped on the inverted conical orifice and the water level adjusted to give the hydrostatic head required. Unless otherwise specified the valve shall then be opened and the appearance of a drop or drops of water at different places of the test area shall be observed and timed. Unless otherwise specified in the procurement document, failure to the test shall be evidenced by the appearance of water at three different places within the 4-1/2 inch (114 mm) diameter test area.

6. REPORT

6.1 Measure of the amount of water penetration. The water permeability of the sample unit shall be the average of the results obtained from the specimens tested and shall be reported to the nearest ml.

6.2 Measure of the appearance of water drops. The water permeability of the sample unit determinations shall be reported separately as "Pass" or "Fail".

6.3 Each individual value used to calculate the average shall also be reported.

7. NOTES

7.1 A hydrostatic testing apparatus of the type described in this method may be obtained from:

The Alfred Suter Company, 200 Fifth Avenue, New York, NY 10010; or from the Richmond Machine Company, 3375 Richmond Street, Philadelphia, PA 19134.

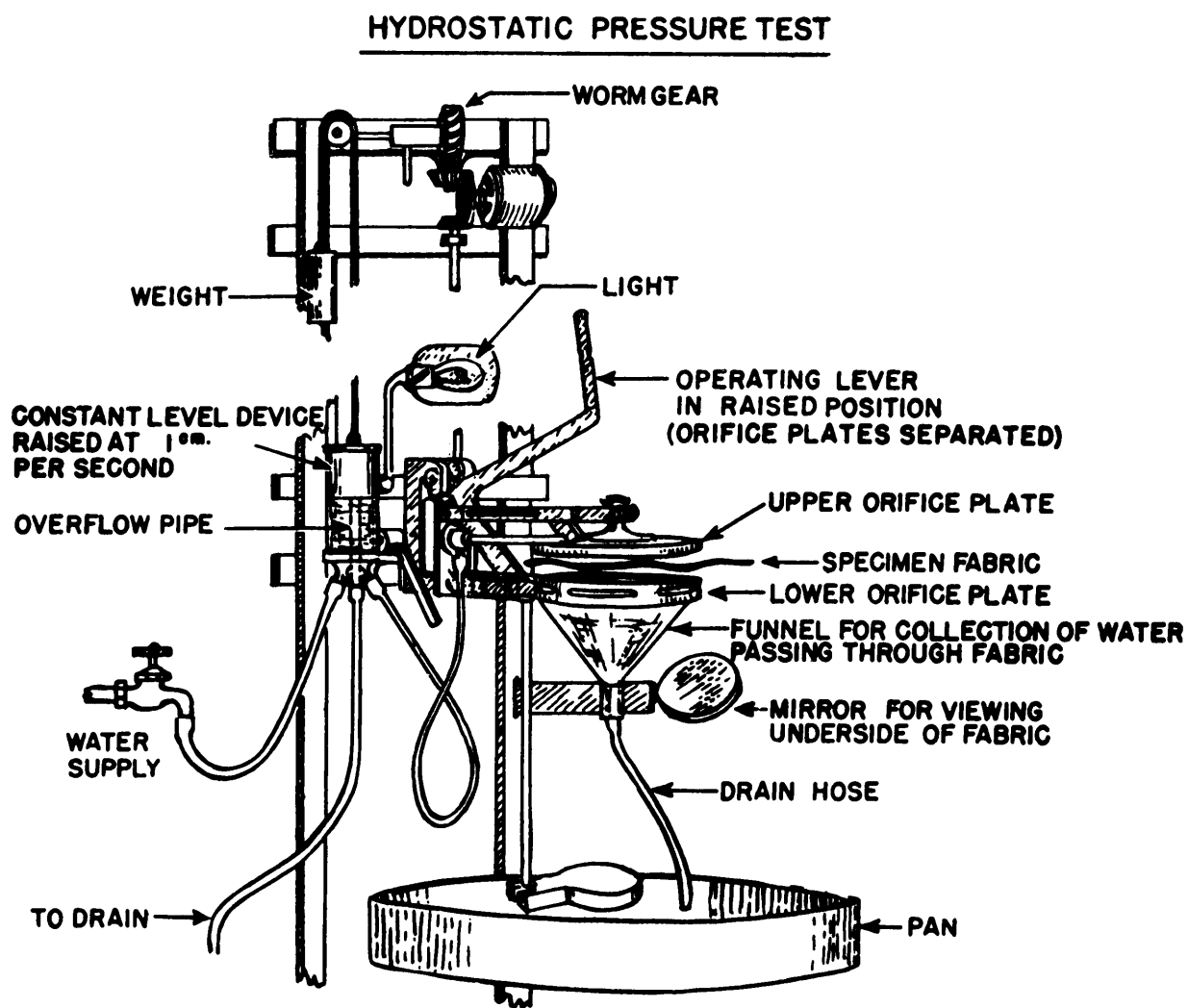

FIGURE 5516

METHOD 5518
July 20, 1978

LAUNDERING RESISTANCE OF CLOTH WITH WATER-RESISTANT
FINISH; WASH WHEEL (WET MECHANICAL ACTION) METHOD

1. SCOPE

1.1 This method is intended for determining the resistance of water resistant finishes on cloth to laundering and wet mechanical action.

2. TEST SPECIMEN

2.1 The specimen shall consist of 3/4 yard (0.69 m) to 1-1/2 yard (1.37 m) length of the cloth, depending on the width of the cloth and the specimen size requirements of the subsequent water resistance tests.

3. NUMBER OF DETERMINATIONS

3.1 Unless otherwise specified in the procurement document, three specimens shall be tested from each sample unit.

4. APPARATUS, REAGENTS AND METHODS CITED

4.1 Apparatus.

4.1.1 Wash wheel (see 7.1). A cylindrical wash wheel of the reversing type shall be used. The wheel (cage) shall be 20 to 24 inches (508 to 610 mm) inside diameter and 20 to 24 inches (508 to 610 mm) inside length. There shall be 3 fins each approximately 3 inches (76 mm) extending the full length of the inside of the wheel. One fin shall be located every 120° around the inside diameter of the wheel. The wash wheel shall rotate at a speed of 30 ± 4 revolutions per minute making 5 to 10 revolutions before reversing. The water inlets shall be large enough to permit filling the wheel to an 8 inch (203 mm) level in less than 2 minutes, and the outlet shall be large enough to permit discharge of this same amount of water in less than 2 minutes. The machine shall be equipped with a pipe for injecting live steam that shall be capable of raising the temperature of water at an 8 inch (203 mm) level from 100° to 140°F (38° to 60°C) in less than 2 minutes.

4.1.2 Extractor. A centrifugal extractor of the laundry-type with a perforated basket, approximately 11 inches (279 mm) deep by 17 inches (432 mm) in diameter, with an operating speed of approximately 1500 revolutions per minute.

METHOD 5518

4.1.3 Circulating-air oven. A circulating-air oven, thermostatically controlled and capable of maintaining the required temperature within a tolerance of $\pm 5^{\circ}\text{F}$ ($\pm 3^{\circ}\text{C}$).

4.1.4 Weight. Weight of approximately 50 pounds (23 kg) for cold pressing the specimen.

4.1.5 Ballast. Ballast composed of pieces of material of the same size and similar to the specimen in weight.

4.2 Reagents.

4.2.1 Water. Water suitable for laundering (not over 50 ppm in hardness calculated as CaCO_3).

4.2.2 Detergent. Soap conforming to the requirements of P-S-1792, Soap, Laundry (Neutral and Built) Type I, Classes 1 or 2, which shall be added directly to the wash wheel or made into a suitable stock solution.

4.2.3 Sour. Sour conforming to the requirements of P-S-683, Sour, Laundry (Fluoridated) Type I or Type II.

4.3 Methods cited.

Method 5526, Water Resistance of Cloth with Hydrophobic Finish:
Spray Method.

Method 5528, Water Resistance of Coated Cloth: Spray Method.

5. PROCEDURE

5.1 Laundering. Water at the designated temperature found in table I, $\pm 5^{\circ}\text{F}$ ($\pm 3^{\circ}\text{C}$) shall be poured into the wash wheel to the required level specified in table I. The specimen and approximately a total of 6 linear yards (5.5 linear m) of fabric 30 to 42 inches (762 to 1067 mm) wide or equal ballast (pieces cut to approximately the size of specimen) shall then be placed in the wash wheel and subjected to the treatment specified in table I. The last minute of each operation specified shall be used for draining the machine. During this draining time the machine shall be in motion. At the end of each operation the machine shall be stopped and water at the designated temperature added to the proper level before starting the machine again.

TABLE I

Operation	Composition of washing bath (Treatment)	Water level in wheel		Temperature		Running time Minutes
		Inches	(mm)	°F	(°C)	
1	Soap, 2 oz. (57 gm)	4	(102)	160	(71)	10
2	"	4	(102)	160	(71)	10
3	Water	6	(152)	160	(71)	10
4	"	6	(152)	160	(71)	10
5	"	6	(152)	160	(71)	10
6	"	4	(102)	160	(71)	15
7	"	4	(102)	160	(71)	15
8	"	4	(102)	160	(71)	15
9	Sour, 1 oz. (28.3 g) per 10 gal. (37.9 L) Water	4	(102)	120	(49)	15
10	Water	4	(102)	90	(32)	10

5.2 After laundering, the specimen shall be extracted for 5 to 7 minutes and dried at $160^{\circ} \pm 5^{\circ}\text{F}$ ($71^{\circ} \pm 3^{\circ}\text{C}$) for 60 minutes in a circulating-air oven. Clean dry cloth shall be used to protect the specimen from dirt or screen marks during drying.

5.3 The above operation shall be repeated for each specimen taken from each sample unit. However, specimens taken from another sample unit may be tested simultaneously by substituting the specimens for a like number of ballast pieces. The total number of pieces including specimens and ballast pieces shall not exceed approximately 6 linear yards (5.5 linear m) of fabric 30 to 42 inches (762 to 1067 mm) wide or the equivalent.

5.4 The dry specimen shall be cold pressed by placing a large flat weight of approximately 50 lbs. (23 kg) on a maximum of 15 cloth thicknesses, for a minimum of 1 hour prior to conditioning for the water resistance tests.

METHOD 5518

5.5 The water resistance of the specimen shall be determined by Method 5526 or 5528, or any other method as specified in the procurement document. The same tests shall be conducted on the cleaned specimen and on a specimen which has not been cleaned for the purpose of comparison in determining the degree of water resistance of the cleaned cloth.

5.6 Calculation of results. The results shall be calculated as described in the method of test used for determining water resistance.

6. REPORT

6.1 Unless otherwise specified in the procurement document, the results shall be reported as described in the method of test used for determining water resistance.

7. NOTES

7.1 A wash wheel of the type described in this method is available from:

Ewing Division of Power Com
P.O. Box 454
Troy, NY 12181

METHOD 5519
July 20, 1978

LAUNDERING TEST, ACCELERATED; FOR LABELS

1. SCOPE

1.1 This method is intended for determining the fastness of the markings of labels to an accelerated laundering procedure.

2. TEST SPECIMEN

2.1 Labels 2 inches by 3 inches (51 by 76 mm) and larger. The test specimen shall be a number of rectangles, each measuring approximately 2 inches by 3 inches (51 by 76 mm) weighings total of 3.5 ± 0.3 g.

2.2 Labels smaller than 2 inches by 3 inches (51 by 76 mm). Labels shall be lap stitched together with all printing in the same plane to give a total area of approximately 2 inches by 3 inches (51 by 76 mm).

2.3 Each test specimen unit shall be pinked along each edge (see 7.1).

3. NUMBER OF DETERMINATIONS

3.1 Unless otherwise specified in the procurement document, one specimen shall be tested from each sample unit.

4. APPARATUS AND REAGENTS

4.1 Apparatus.

4.1.1 Accelerator. A machine capable of varying the speed of the rotor from 0 to 4000 revolutions per minute with a 4-1/2 inch (114 mm) 'S' rotor. The liner for the test chamber shall be rubber ribbed, having 2 ribs per inch (25 mm), with the ribs approximately 1/16 inch (2 mm) in height (see 7.2).

4.1.2 Soaking chamber. Any convenient vessel with 100 ml per g of specimen capacity.

4.1.3 Pressing equipment.

4.1.3.1 Steam pressing. Flat bed press at a temperature of 275° to 300°F (135° to 149°C) having hot head or polished metal top for flat cloths or cloth covered press for rough crepes.

4.1.3.2 Hand iron. A hand iron weighing approximately 6 pounds (2.7 kg), capable of maintaining temperatures between 275° to 300°F (135° to 149°C).

FED. TEST METHOD STD. NO. 191A

METHOD 5519

4.2 Reagents.

4.2.1 Soap and alkali solution. A soap and alkali solution dissolved in water of not over 50 parts per million hardness and containing:

4.2.1.1 Detergent. 0.2 percent soap conforming to the requirements of P-S-1792, Soap, Laundry (Neutral and Built), Type I, Class 1.

4.2.1.2 Sodium metasilicate. 0.2 percent sodium metasilicate, conforming to the requirements of 0-S-604, Sodium Metasilicate, Technical, Type I.

4.2.1.3 Sodium carbonate. 0.07 percent sodium carbonate, conforming to the requirements of 0-S-571, Sodium Carbonate, Anhydrous, Technical, Type I.

5. PROCEDURE

5.1 When a standard sample has been established for fastness to laundering, Method A shall be used for evaluating the fastness of the labels. When no standard sample has been established, Method B shall be used for evaluating the fastness of the labels.

5.2 When a standard or comparison sample has been established, the standard or comparison sample shall be tested under the same conditions as the specimen undergoing the test.

5.3 The specimens shall be crumpled by hand to prevent one specimen from adhering to another. The specimens shall be immersed in the soap and alkali solution for 30 ± 2 minutes at $150^\circ \pm 5^\circ\text{F}$ ($66^\circ \pm 3^\circ\text{C}$) at a ratio of 100 ml of solution per g of material.

5.4 The specimens shall then be placed in the Accelerator with 150 ml of the soap and alkali solution at $80^\circ \pm 2^\circ\text{F}$ ($27^\circ \pm 1^\circ\text{C}$). The speed control shall be set to approximately 50. The motor shall then be started and quickly adjusted to 2000 revolutions per minute. Average speed shall be used since the tachometer pointer will fluctuate.

5.5 The machine shall be run for 6 minutes \pm 10 seconds (including that time to adjust the initial speed) without further adjustment of speed.

5.6 At the end of the 6 minute running time, the machine shall be shut off and the liquid allowed to drain out. The specimens shall be removed, squeezed by hand, and then rinsed free of soap with water of not over 50 parts per million hardness and having a temperature of approximately 105°F (41°C). The specimens shall then be extracted or passed between wringer rolls to remove excess water and then dried with a hand iron or flat bed press between clean white cloths.

METHOD 5519

5.7 Evaluation. Change in definition of print shall be considered in rating fastness of labels to laundering. The evaluation shall be performed under artificial daylight, having a color temperature of 7500 kelvin.

5.7.1 Method A - Standard sample. When a standard or comparison sample has been established, the test specimen shall be compared with the standard or comparison sample and rated as follows:

Pass - Equal or superior to the standard sample.

Fail - Inferior to the standard sample.

5.7.2 Method B - No standard sample. When no standard sample for comparison has been established, the test specimen shall be rated as to definition of print and legibility of print at a distance of eighteen inches (457 mm) as follows:

Excellent - Practically no change in legibility or definition of print.

Good - Readily legible without difficulty.

Fair - Legible without need for deciphering.

Poor - Not readily legible, requiring deciphering.

6. REPORT

6.1 Standard sample. When a standard sample has been established, fastness to laundering shall be reported as "Pass" or "Fail".

6.2 No standard sample. When no standard sample has been established, fastness to laundering shall be reported as "Pass" or "Fail". When failure is noted, legibility shall be reported by the adjective rating, i.e. "Good", "Fair" or "Poor".

7. NOTES

7.1 If the material for test is subject to excessive raveling, a thin ribbon of a latex acrylic adhesive shall be applied to each pinked edge. The following adhesive has been found satisfactory for the described use:

Vulcanol A1 - 100 - 58

This adhesive may be obtained from:
Alto Oil and Chemical Corporation
Trenton Avenue and William Street
Philadelphia, PA 19125

METHOD 5519

7.2 An Accelerator of the type described in this method may be obtained from the Atlas Electric Devices Company, 4114 North Ravenswood Avenue, Chicago, IL 60613.

METHOD 5520
July 20, 1978

WATER RESISTANCE OF CLOTH; DROP PENETRATION METHOD

1. SCOPE

1.1 This method is intended for determining the resistance to penetration of water through cloth by use of water drop impact. It is especially applicable to cloth treated with water repellents.

2. TEST SPECIMEN

2.1 The specimen shall consist of a square of cloth 8 inches by 10 inches (203 by 254 mm) with the long dimension in the warp direction.

3. NUMBER OF DETERMINATIONS

3.1 Unless otherwise specified in the procurement document, five specimens shall be tested from each sample unit.

4. APPARATUS (See figure 5520)

4.1 Drop penetration apparatus. Drop-forming device composed of 31 capillary tubes cemented into a plate which in turn shall be cemented into a cylindrical holder having an inside diameter of 4-1/2 inches (114 mm) and a height of 8 inches (203 mm).

4.1.1 Capillaries. The outside diameter of the capillaries shall be $5.5 \pm .5$ mm (0.2165 ± 0.0157 inch) and the inside diameter approximately 0.4 mm (0.0157 inch). These dimensions are intended to give a rate of dropping of approximately 1 drop per second with an appropriate constant hydrostatic head. The variation in dropping time between the fastest and slowest drops shall not exceed 15 percent.

4.1.2 The drop forming device shall be mounted rigidly and shall be protected from air currents by a cylindrical or square shield extending at least 1 inch (25 mm) above the lower surface of the capillaries.

4.2 Specimen holder. A specimen holder consisting of a flat bakelite plate 10 inches (254 mm) square with a 6-inch (152 mm) clamp mounted along the upper edge. An arc-shaped section 3/4 inch (19 mm) in width with an outside radius of 3 inches (76 mm) shall be cut from the plate.

4.2.1 The holder shall be mounted at a 45° angle within a rectangular box so that the vertical distance from the lower tips of the capillary tubes to the center of the specimen holder is 5 feet 8 inches (1.73 m).

METHOD 5520

4.2.2 The holder shall be placed over a 10-inch (254 mm) square metal plate mounted at 45° to the horizontal. It shall be so positioned on the plate that the cut-out section coincides with the lower lip of the container. In the center of this plate is a 6-inch (152 mm) hole to which is soldered a hemispherical or cylindrical container. A spout 1/4 inch (6 mm) in diameter shall lead from the bottom of the container to a graduated cylinder outside the test box.

4.2.3 The position of the holder shall be such that the drops of water impinge only on that portion of the specimen above the cut-out section in the holder, and drops falling from the respective capillaries shall impinge on the same point during the test.

4.3 Graduated cylinder, 10 ml.

4.4 Stop watch. A stop watch or other timing device which will indicate the time in seconds and minutes.

5. PROCEDURE

5.1 Unless otherwise specified in the procurement document, the temperature of the water shall be maintained at 80° ± 5°F (27° ± 3°C) during the test.

5.2 Previous to the start of the test 5 to 10 ml of water shall be used to flush out the cylinder.

5.3 The specimen shall be placed in the holder with the warp end held by the clamp at the upper edge of the specimen holder and shall be kept under tension by means of a total weight of 1 pound (0.45 kg) attached to the lower warp end of the specimen by means of a 6-inch (152 mm) clamp hanging freely over the lower edge of the bakelite plate.

5.4 The specimen holder and cloth shall be placed on the 45° angle specimen support in the path of the drops, and the timing device shall be started concurrently.

5.5 The water which passes through the specimen and drains through the cut-out section in the bakelite plate shall be drawn off the holder into the bottom of the container and measured in the graduated cylinder.

5.6 The time necessary to collect 10 ml of water shall be recorded.

6. REPORT

6.1 The drop penetration of the sample unit shall be the average of the results obtained from the specimens tested and shall be reported to the nearest 1.0 second.

6.2 Each individual value used to calculate the average shall also be reported.

DROP PENETRATION APPARATUS

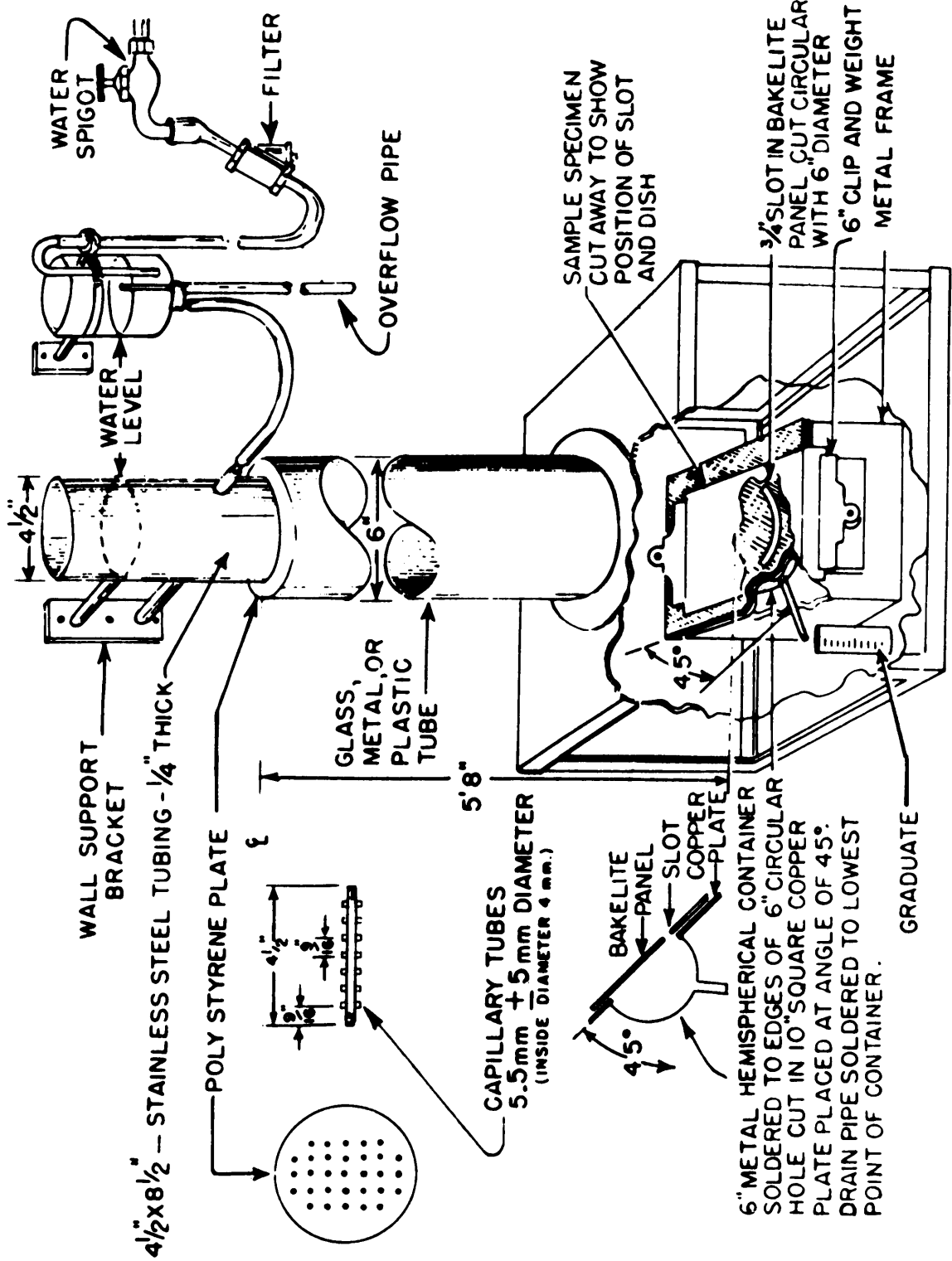

FIGURE 5520

METHOD 5522
July 20, 1978

WATER RESISTANCE OF CLOTH;

WATER IMPACT PENETRATION METHOD

1. SCOPE

1.1 This method is intended for determining the resistance of closely woven cloth to the penetration of water. This procedure may be used for either treated or untreated cloths.

2. TEST SPECIMEN

2.1 The specimen shall be a rectangle of cloth 7 inches by 13 inches (178 by 330 mm) with the long dimension in the warp direction of the finished cloth.

3. NUMBER OF DETERMINATIONS

3.1 Unless otherwise specified in the procurement document, three specimens shall be tested from each sample unit.

4. APPARATUS AND METHOD CITED

4.1 Apparatus.

4.1.1 The apparatus shall be as described in Method 5526, figure 5526A, with the following exceptions or additions:

4.1.1.1 Spring clamp. A 6-inch (152 mm) spring clamp shall be fastened at the top of the inclined stand to hold the specimen.

4.1.1.2 Free 6-inch (152 mm) spring clamp and weight totaling 1 pound (0.45 kg).

4.1.1.3 The end of the nozzle shall be 24 inches (610 mm) above the center of the specimen.

4.1.1.4 Balance. A laboratory balance capable of weighing the specimen to an accuracy of 0.1 g.

4.1.1.5 Blotting paper. The blotting paper dimensions shall be 6 inches by 9 inches (152 by 229 mm) (see 7.1).

4.2 Distilled water.

METHOD 5522

4.3 Method cited.

Method 5526, Water Resistance of Cloth with Hydrophobic Finish; Spray Method.

5. PROCEDURE

5.1 The test shall be performed under standard atmospheric conditions for textiles in accordance with Section 4 of this Standard. The blotting paper and specimen shall be in equilibrium with the above conditions. The specimen, with the finished side up, shall be clamped on the warp end by the 6 inch (152 mm) spring clamp (see 4.1.1.1), and on the other end by the free 6 inch (152 mm) clamp (see 4.1.1.2). The blotting paper shall be weighed to the nearest 0.1 g. This is the "Original weight of the blotter" and is designated as "O".

5.2 The blotter shall be inserted beneath the specimen. A 500 ml volume of distilled water at a temperature of $80^{\circ} \pm 2^{\circ}\text{F}$ ($27^{\circ} \pm 1^{\circ}\text{C}$) shall be poured into the funnel and allowed to spray onto the test specimen. The water shall be poured into the funnel without imparting any swirling motion to the water in the funnel. (A small blade fixed to the inside of the funnel and extending down its side will prevent such a swirling motion).

5.3 Upon completion of the spraying period, the specimen shall be carefully lifted from the blotter. The blotter shall be removed and quickly reweighed to the nearest 0.1 g. This is the "Final weight of the blotter" and shall be designated as "F".

5.4 Calculation of results. The weight of water penetrated shall be calculated as follows:

$$\text{Water penetration} = F - O$$

Where: O = Original weight of the blotter.

F = Final weight of the blotter.

6. REPORT

6.1 The water penetration of the sample unit shall be the average of the results obtained from the specimens tested and shall be reported to the nearest 0.1 g.

6.2 Each individual value used to calculate the average shall also be reported.

7. NOTES

7.1 The blotting paper is available from: James River Paper Company, P.O. Box 2218, Richmond, VA 23217.

WATER RESISTANCE OF CLOTH;

RAIN PENETRATION METHOD

1. SCOPE

1.1 This method is intended for determining the resistance to penetration by water of cloth made from all types of fibers whether or not they have been given a water-resistant finish. In the interest of standardization of testing requirements, it is recommended that this method not be used in procurement documents.

2. TEST SPECIMEN

2.1 The specimen shall be a square of cloth 8 inches by 8 inches (203 mm by 203 mm). When more than one layer of the cloth is required to be subjected to a single spraying operation, the total number of squares shall be considered as a specimen.

2.2 As specified in the procurement document, the specimen shall comprise of:

- (a) A single layer of cloth.
- (b) Multiple layers of the cloth.
- (c) A combination of two different cloths, as a raincoat and the lining cloth.

3. NUMBER OF DETERMINATIONS

3.1 Unless otherwise specified in the procurement document, three specimens (at each required intensity) shall be tested from each sample unit.

4. APPARATUS

4.1 Spray assembly. A spray assembly such that a horizontal water spray from a nozzle is directed against the specimen which is placed at right angles to the spray and 12 inches (305 mm) from the nozzle. The different intensities of spray shall be produced by means of a column of water, adjustable to heights of 2, 3, 4, 5, 6, 7, and 8 feet (.61, .91, 1.22, 1.52, 1.83, 2.13 and 2.44 meters) above the nozzle.

4.1.1 Spray nozzle. Nozzle with 13 holes, each 0.0390 ± 0.0005 inch ($1 \pm .01$ mm) in diameter (No. 61 drill), and equipped with a removable shield.

METHOD 5524

4.1.2 Specimen holder. The specimen holder shall be equipped with clamps suitable for holding the specimen and blotter in a vertical and rigid position during the spray period.

4.2 Blotting paper. The blotting paper dimensions shall be 6 inches by 6 inches (152 by 152 mm) (see 7.1).

4.3 Balance. A laboratory balance capable of weighing the specimen to an accuracy of 0.1 g.

4.4 Temperature controller. Means of maintaining the temperature of the water at $80^{\circ} \pm 5^{\circ}\text{F}$ ($27^{\circ} \pm 3^{\circ}\text{C}$) and introducing it at the bottom of the glass pressure column.

5. PROCEDURE

5.1 The number of layers of cloth required for one spray operation and the spray intensity or intensities of the pressure column shall be as specified in the procurement document.

5.2 In order to obtain a complete over-all picture of the penetration resistance of a cloth or cloth combination, the average penetration with different pressure heads on the nozzle may be obtained. The pressure head should be varied by 1-foot (305 mm) increments in order to determine:

- (a) The maximum head at which no penetration occurs.
- (b) The change in penetration with increasing head.
- (c) The minimum head required to cause "breakdown" or the penetration of more than 10 g of water.

5.3 The shield shall be placed over the spray nozzle and the overflow regulated to give the desired hydrostatic pressure. The flow of water shall be adjusted so that a steady overflow at a temperature of $80^{\circ} \pm 5^{\circ}\text{F}$ ($27^{\circ} \pm 3^{\circ}\text{C}$) is maintained during the test.

5.4 The specimen and the blotting paper shall be conditioned before testing and the blotting paper weighed to the nearest 0.1 g. This is the "Original weight of the blotter" and shall be designated as "0". The weighed blotter shall be placed on the specimen holder between but not touching the clamps and the specimen clamped over it. The specimen shall be free from wrinkles and clamped tightly enough to hold the blotter in place when the specimen holder is in a vertical position.

5.5 The specimen holder with the specimen and blotter in test position, shall be placed so that it is in a vertical position, with the center of the specimen directly opposite and 12 inches (305 mm) from the face of the spray

METHOD 5524

nozzle. The shield shall be removed from the spray nozzle and the water allowed to spray horizontally onto the cloth for 300 ± 1 seconds. The nozzle shield shall then be replaced, the specimen holder removed from its support, and the specimen removed from the specimen holder; care should be taken not to allow any water to run from it onto the blotter beneath. The blotter shall be reweighed to the nearest 0.1 g; care shall be taken to minimize any loss of weight by evaporation of water from the blotter. This is the "Final weight of the blotter" and shall be designated as "F".

5.6 Calculation of results. The weight of water penetrated shall be calculated as follows:

$$\text{Water penetration} = F - O$$

Where: O = original weight of the blotter.

F = Final weight of the blotter.

6. REPORT

6.1 The water penetration of the sample unit shall be the average of the results obtained from the specimens tested and shall be reported to the nearest 0.1 g.

6.2 The individual values used to calculate the average shall also be reported.

7. NOTES

7.1 The blotting paper is available from:

James River Paper Company
P.O. Box 2218
Richmond, VA 23217

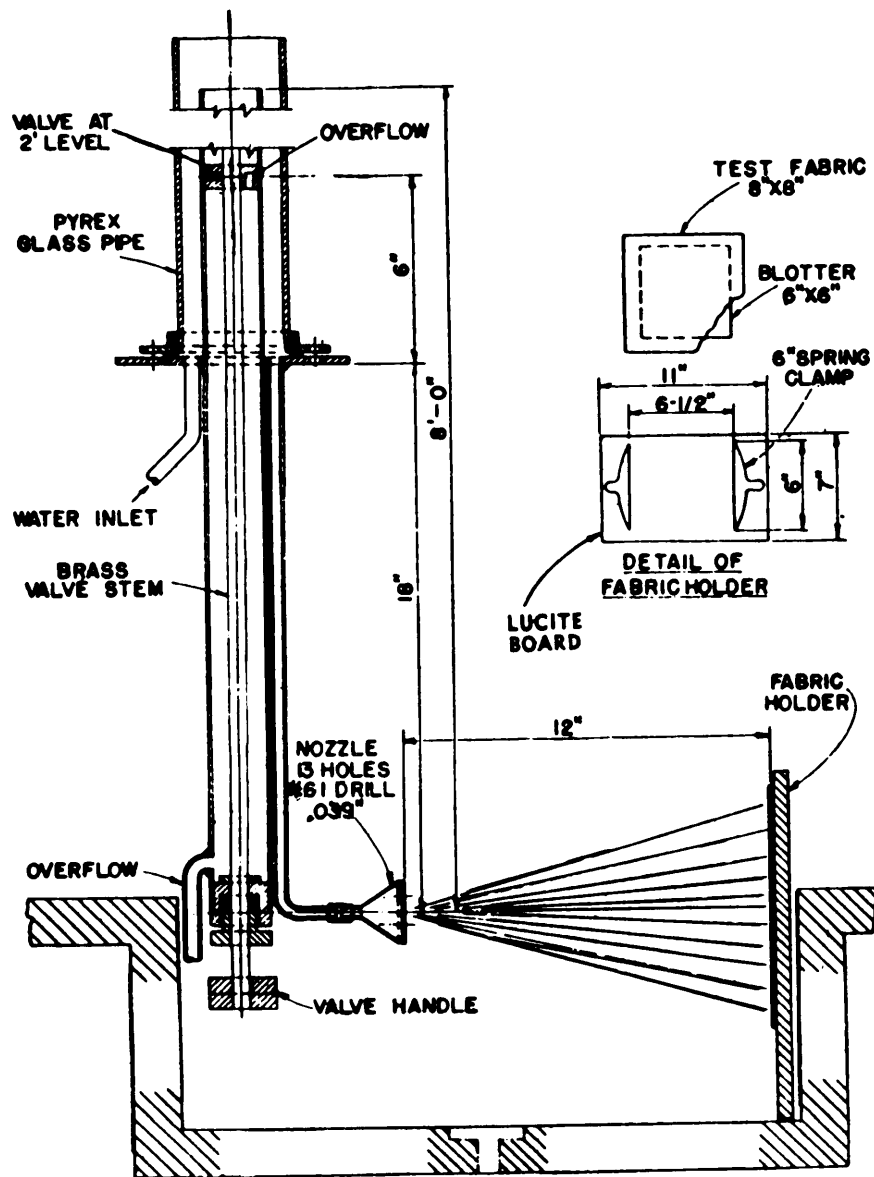

Rain Tester (Structural Details).

FIGURE 5524

WATER RESISTANCE OF CLOTH WITH HYDROPHOBIC FINISH;

SPRAY METHOD

1. SCOPE

1.1 This method is intended for determining the hydrophobic effectiveness of water-repellent finishes applied to cloth by measuring the amount of water absorbed.

2. TEST SPECIMEN

2.1 The specimen shall be a square of cloth 8 inches by 8 inches (203 by 203 mm).

3. NUMBER OF DETERMINATIONS

3.1 Unless otherwise specified in the procurement document, three specimens shall be tested from each sample unit.

4. APPARATUS (See figure 5526A)

4.1 Funnel. A six-inch (152 mm) glass laboratory funnel held by a laboratory ring support.

4.2 Spray nozzle. A spray nozzle of 1-7/16 inch (36.5 mm) outside diameter having a convex face with a 1-1/4 inch (32 mm) radius and connected to the funnel with a piece of 3/8 inch (10 mm) rubber tubing.

4.2.1 Nozzle. The nozzle shall be provided with 19 holes, 0.035 inch (0.89 mm) in diameter (No. 65 drill), having 1 hole in the center, 6 evenly spaced holes on a 25/64 inch (9.9 mm) diameter circle concentric with the outside circumference of the nozzle.

4.2.2 The distance from the top of the funnel to the bottom of the nozzle shall be 7-1/2 inches (190 mm).

4.3 Embroidery hoops. Metal embroidery hoops 6 to 7 inches (152 to 178 mm) in diameter for mounting the specimen.

4.4 Block of wood for supporting the mounted specimen so that the plane of the specimen makes an angle of 45° with the horizontal.

METHOD 5526

4.5 The distance from the bottom of the nozzle to the center of the hoop-mounted specimen shall be 6 inches (152 mm).

4.6 Distilled water.

5. PROCEDURE

5.1 Unless otherwise specified in the procurement document, the specimen shall be securely mounted, finished side up, in the embroidery hoops with sufficient tension to insure a uniformly smooth surface.

5.2 Unless otherwise specified in the procurement document, the direction of the flow of water down the specimen shall coincide with the warpwise direction of the specimen as placed on the stand.

5.3 The mounted specimen shall be placed on the block with the center of the specimen directly beneath the center of the nozzle and the plane of the surface of the specimen at a 45° angle with the horizontal.

5.4 A 250 ml volume of distilled water at a temperature of 80° ± 2.0°F (27° ± 1°C) shall be poured quickly into the funnel and allowed to spray onto the specimen which should take approximately 25 to 30 seconds.

5.5 Upon completion of the spraying period, the hoop shall be grasped at one edge and the opposite edge tapped downward against a solid object, the wet side of the specimen being face down during tapping. The hoop shall then be turned 180°, grasped at the opposite edge, and similarly tapped at the point previously held.

5.6 After tapping, the finished side of the cloth shall be compared with the standard figure 5526B and the wetted and/or spotted pattern on the specimen assigned a rating corresponding to the nearest standard rating.

5.6.1 No attempt shall be made to assign to the cloth an intermediate rating, i.e., 60, 75, etc.

5.6.2 In rating light porous cloth, passage of water through the open construction of the cloth shall be disregarded.

6. REPORT

6.1 A spray rating corresponding to the nearest standard in the rating chart shall be reported for each specimen tested.

6.2 No estimates of ratings falling between standards is allowed.

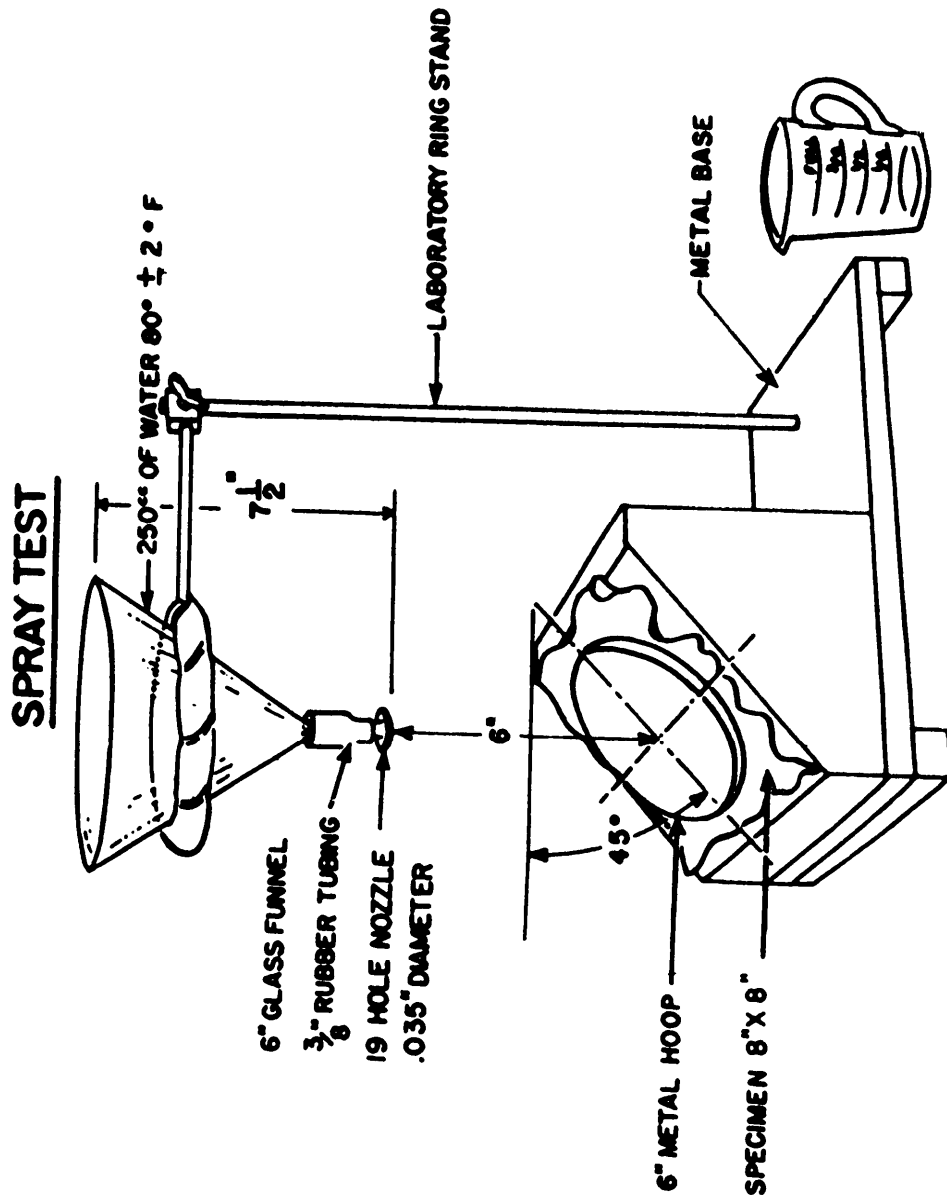
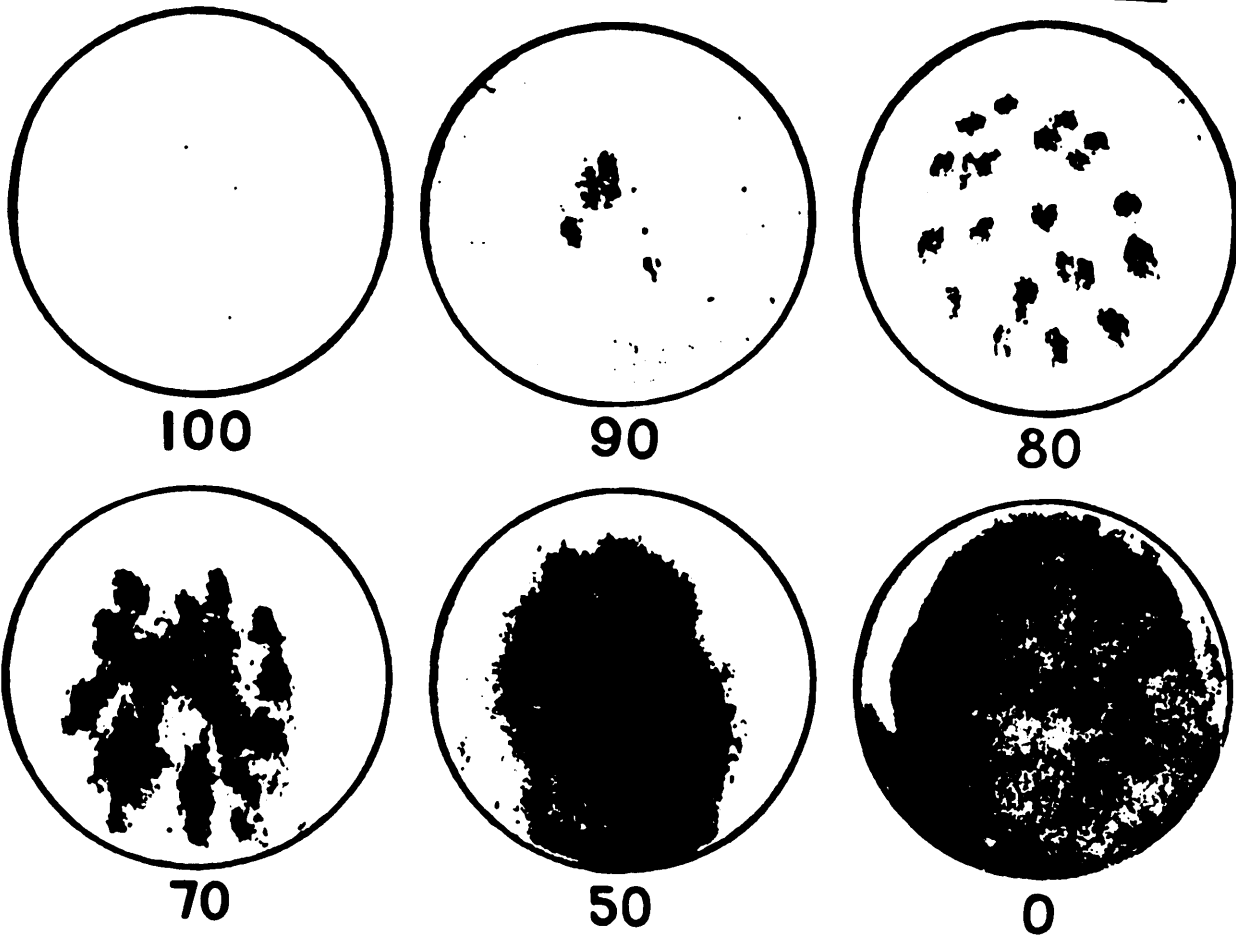

FIGURE 5526A

STANDARD SPRAY TEST RATINGS



- 100- NO STICKING OR WETTING OF UPPER SURFACE.
 90- SLIGHT RANDOM STICKING OR WETTING OF
 UPPER SURFACE.
 80- WETTING OF UPPER SURFACE AT SPRAY POINTS.
 70- PARTIAL WETTING OF WHOLE UPPER SURFACE.
 50- COMPLETE WETTING OF WHOLE OF UPPER SURFACE.
 0- COMPLETE WETTING OF WHOLE OF UPPER AND
 LOWER SURFACES.

— COLORED WATER USED FOR PHOTOGRAPHIC EFFECT —

FIGURE 5526B

METHOD 5528
July 20, 1978

WATER RESISTANCE OF COATED CLOTH; SPRAY METHOD

1. SCOPE

1.1 This method is intended for determining the effectiveness of waterproof coatings when applied to fabrics for use in the manufacture of such items as flotation bladders, raincoats, food wrappers, clothing and sleeping bags.

2. TEST SPECIMEN

2.1 The specimen shall be a square of the finished cloth 8 inches (203 mm) if cut, or an equivalent square section if not cut.

3. NUMBER OF DETERMINATIONS

3.1 Unless otherwise specified in the procurement document, four specimens shall be tested from each sample unit. Leakage shall be determined on 2 specimens, adhesion on 2 specimens, and softening on each of the 4 specimens.

4. APPARATUS AND METHODS CITED

4.1 Apparatus.

4.1.1 The apparatus shall be as described in Method 5526 except that a wood backing shall be provided for the specimen instead of the hoop, and provisions shall be made for maintaining a constant volume of 250 ml of water in the funnel during the test.

4.2 Methods cited.

Method 5512, Water Resistance of Coated Cloth; High Range, Hydrostatic Pressure Method.

Method 5526, Water Resistance of Cloth with Hydrophobic Finish; Spray Method.

Method 5970, Adhesion of Coating; Adhesive Method.

5. PROCEDURE

5.1 Unless otherwise specified in the procurement document, the specimen shall be securely mounted on the wood backing and its coated side subjected to a 2-hour spray of water. The temperature of the water shall be $80^{\circ} \pm 2.0^{\circ}\text{F}$ ($27^{\circ} \pm 1^{\circ}\text{C}$). A constant volume of 250 ml of water shall be maintained in the funnel during the test. Upon completion of the spraying period, the specimen shall be removed from the wood backing and examined as follows:

FED. TEST METHOD STD. NO. 191A

METHOD 5528

5.2 Leakage determination. Leakage through the coating shall be determined by Method 5512.

5.3 Coating adhesion determination. Coating adhesion shall be determined by Method 5970 after the excess water has been removed but while specimen is still wet.

5.4 Softening determination. Softening of the coating shall be determined by applying the thumbnail against the surface of the coating in a skiving motion. Plasticity of the coating shall be stated as no softening, slight softening, or extreme softening when compared to the original unsprayed specimen.

6. REPORT

6.1 Leakage of the sample unit shall be the average of the results obtained from the specimens tested and shall be reported to the nearest 1 pound per square inch (6.89 kPa).

6.2 The adhesion of the coating of the sample unit shall be the average of the results obtained from the specimens tested and shall be reported to the nearest 0.1 pound per 2-inch width (to the nearest 10 N/m).

6.3 For the reports in 6.1 and 6.2 above, each individual value used to calculate the average shall also be reported.

6.4 Each specimen shall be reported separately for no softening, slight softening, or extreme softening.

METHOD 5530
July 20, 1978

PENETRATION RESISTANCE OF CLOTH TO PASSAGE OF
FEATHERS AND DOWN; TUMBLING METHOD

1. SCOPE

1.1 This method is intended for determining the resistance of cloth to the passage of feathers and down. The cloth is tested once as received and again after one wool mobile laundering.

2. TEST SPECIMEN

2.1 The specimen shall consist of one piece of the cloth 25 by 13 inches (635 by 330 mm).

2.1.1 The specimen shall be made into a bag approximately 12 by 13 inches (305 by 330 mm) by folding it on itself and stitching on two sides. The bag shall be turned inside out and the two sides stitched again. The bag shall be stitched midway between and parallel to the two side seams to form two pockets, each 6 by 12 inches (152 by 305 mm).

2.2 Seven-tenths of an ounce (19.8 g) of a mixture of 60 percent waterfowl feathers and 40 percent waterfowl down shall be placed in each pocket of the bag. The open end of the bag shall be folded forming a lap approximately 3/4 inch (19 mm) wide and double-stitched to insure good resistance to penetration by the feathers and down through the seam. The mixture of feathers and down shall meet the requirements of C-F-160 - Feather, Waterfowl; and Down, Waterfowl.

3. NUMBER OF DETERMINATIONS

3.1 Unless otherwise specified in the procurement document, three specimens shall be tested from each sample unit.

4. APPARATUS AND METHOD CITED

4.1 Apparatus.

4.1.1 Rubber stoppers. Sixteen No. 7 solid rubber stoppers weighing 1.00 ± 0.05 pound (0.45 kg ± 0.02 kg).

4.1.2 Box. A box 18 by 18 inches (457 by 457 mm) inside dimensions with smooth inside walls. Plastic or sheet metal walls are suitable. The box is supported on bearings by means of the two shafts fastened to the outside of the box at the center of two opposite sides. A motor is connected to one shaft through a speed reduction drive to rotate the box at a measured speed of 48 ± 2 revolutions per minute. Suitable apparatus is shown in figure 5530A.

FED. TEST METHOD STD. NO. 191A

METHOD 5530

4.2 Method cited.

Method 5556, Mobile Laundry Evaluation for Textile Materials.

5. PROCEDURE

5.1 The bag containing the feathers and down mixture shall be conditioned under standard atmospheric conditions as specified in Section 4 of this Standard for at least 24 hours before testing, and shall be tested in the same atmosphere.

5.2 The box, as specified in 4.1.2, shall be cleaned of feathers, down, and dust from previous tests. The bag containing the feathers and down mixture shall be closed and inserted into the box with the rubber stoppers. The box shall be rotated at 48 ± 2 revolutions per minute for 45 ± 1 minute.

5.3 At the end of the period of rotation of the box, the bag shall be removed from the box and the outer surface examined visually for down and feather penetration and rated in accordance with 5.6. Only one specimen (bag) shall be rotated in the box at one time.

5.4 The specimen (bag and contents) shall then be laundered as described in Method 5556, dried, cleaned of surface debris by gently brushing, conditioned, and the bag and contents again rotated in the box as described in 5.1 and 5.2. At the end of the period of rotation, the bag shall be removed from the box and the outer surface examined visually for down and feather penetration and rated in accordance with 5.6.

5.5 The feather and down mixture shall be discarded after the completion of the test of one specimen.

5.6 Evaluation. The specimen both before and after laundering shall be rated as follows:

Satisfactory - Feather or down penetration not exceeding that illustrated by figure 5530B.

Unsatisfactory - Feather or down penetration in excess of that illustrated by figure 5530B.

6. REPORT

6.1 The feather and down retention of the specimen (cloth) both before and after laundering shall be reported as "Satisfactory", or "Unsatisfactory".

6.2 The feather and down retention of the sample unit shall be the lowest retention rating given to any specimen either original or laundered.

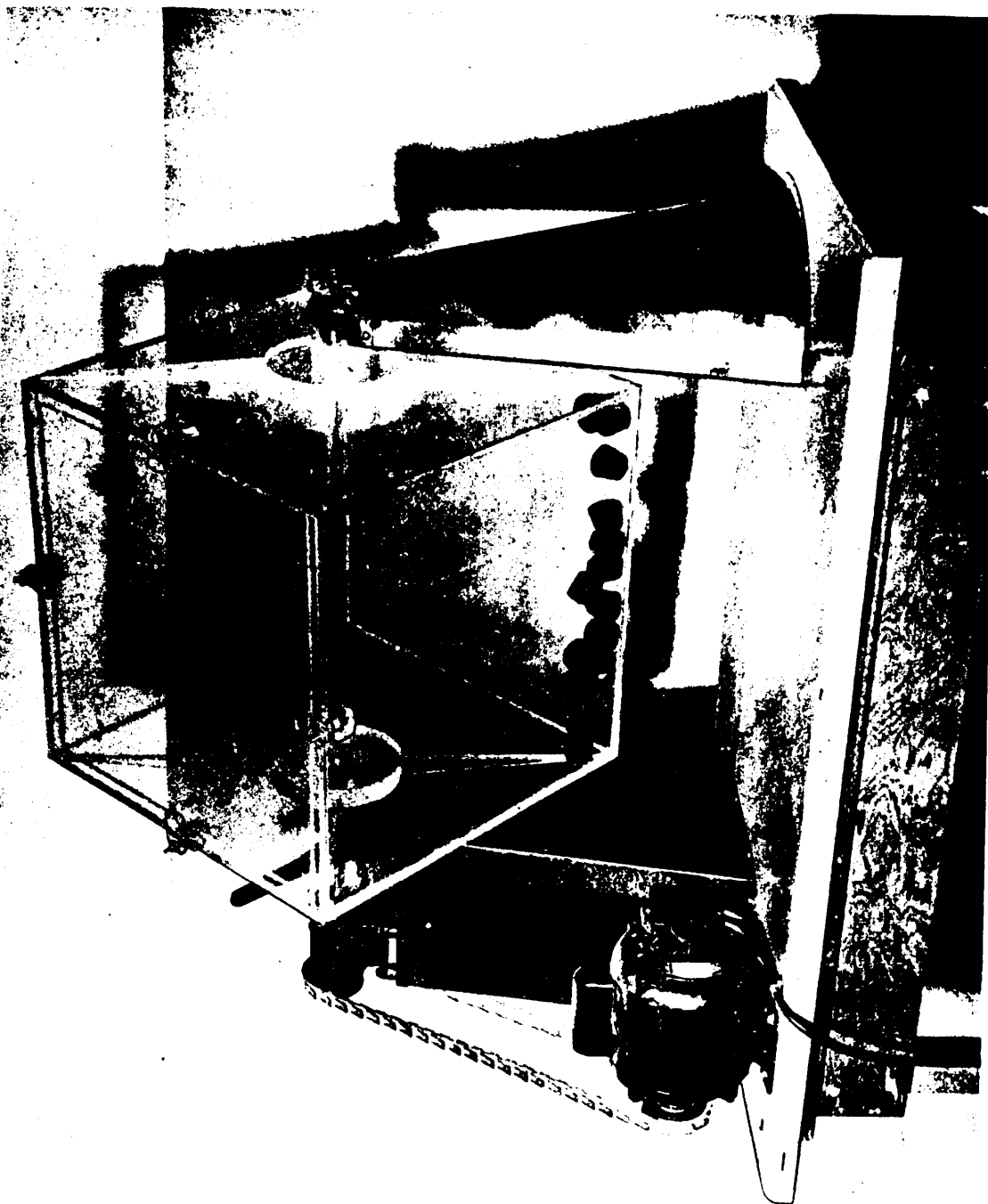

FIGURE 5530A - Rotating box.

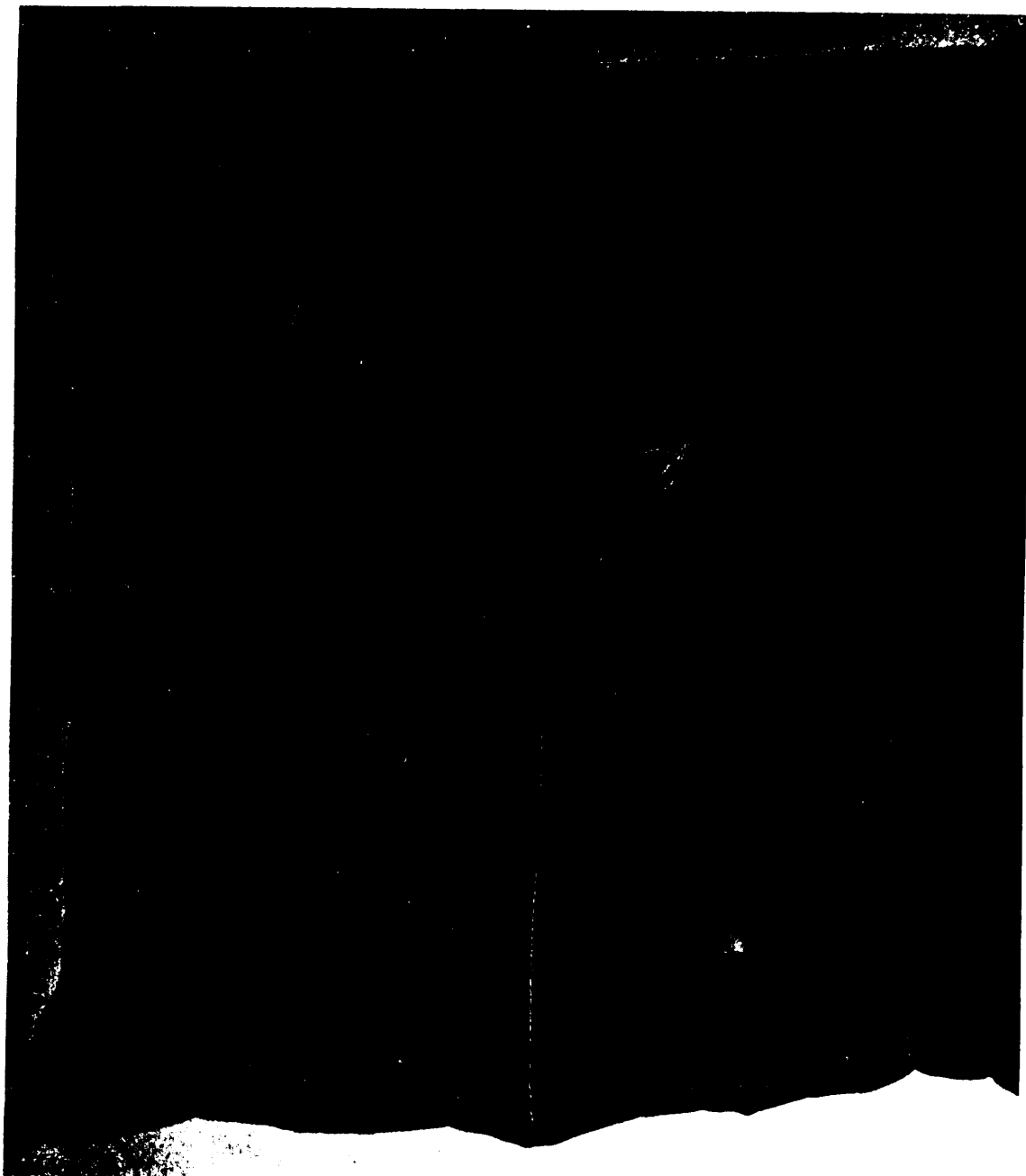

FIGURE 5530B

METHOD 5550
July 20, 1978

SHRINKAGE IN LAUNDERING; COTTON, LINEN, AND
BLENDED COTTON AND LINEN CLOTH

1. SCOPE

1.1 This method is intended for determining the dimensional stability of woven cotton, linen and blended cotton and linen cloth when subjected to a normal laundering procedure. It may be used for some knitted cloths or other items as specified. The dimensional stability is determined by a change in a measured distance of the material after subjection to test.

2. TEST SPECIMEN

2.1 Woven and warp knitted (single layer) cloth. Unless otherwise specified, in the procurement document, the specimen shall be a square of cloth 22 by 22 inches (559 by 559 mm), except for cloth narrower than 22 Inches (559 mm), then the specimen shall be 22 inches (559 mm) long and the entire width of the cloth.

2.2 Cloth 18 inches (457 mm) and less in width. Unless otherwise specified in the procurement document, the specimen shall be at least 22 inches (559 mm) in length and measurements in the width direction shall be the full width of the cloth.

2.3 Circular and tubular knit cloths. Unless otherwise specified in the procurement document, the specimen shall be at least 22 inches (559 mm) in length and the width of the cloth as received.

3. NUMBER OF DETERMINATIONS

3.1 Unless otherwise specified in the procurement document, three specimens from each sample unit shall be tested in each of the warp (wale) and filling (course) directions.

4. APPARATUS AND REAGENT

4.1 Apparatus.

4.1.1 Wash wheel (see 7.1). The wash wheel shall be cylindrical and of the reversing type. The wheel (cage) shall be 20 to 24 inches (508 mm) to 610 mm) inside diameter and 20 to 24 inches (508 mm to 610 mm) inside length. There shall be three fins each approximately 3 inches (76 mm) wide extending the full length of the inside of the wheel. One fin shall be located every 120 degrees around the inside diameter of the wheel. The wash wheel shall rotate at a speed

FED. TEST METHOD STD. NO. 191A

METHOD 5550

of 30 ± 4 revolutions per minute making 5 to 10 revolutions before reversing. The water inlets shall be large enough to permit filling the wheel to an 8 inch (203 mm) level in less than 2 minutes, and the outlet shall be large enough to permit discharge of this same amount of water in less than 2 minutes. The wash wheel shall be equipped with a pipe for injecting live steam that shall be capable of raising the temperature of water at an 8 inch (203 mm) level from 100° to 140°F (38° to 60°C) in less than 2 minutes.

4.1.1.1 The wash wheel shall be equipped with a thermometer or other equivalent equipment for determining the temperature of the water during the washing and rinsing procedures and with an outside water gage that will indicate the level of the water in the wheel.

4.1.2 Pressing equipment. A flat-bed press measuring 24 inches by 50 inches (610 mm by 1270 mm) or larger. Any flat-bed press capable of pressing a specimen 22 inches (559 mm) square or a hand-iron weighing approximately 6 pounds (2.7 kg) may be used as an alternative. The flat-bed press or iron shall be equipped with a temperature control to maintain the temperature between 275° and 300°F (135° and 149°C).

4.1.3 Measuring scale. Yardstick, meterstick, metal tape, or other suitable measuring device graduated in increments of 1/16 inch (1 mm).

4.1.4 Drying equipment.

4.1.4.1 Rack and drying trays. A rack and tray of any convenient size over 22 by 22 inches (559 by 559 mm). The bottoms of the trays shall be a wire mesh, and the size of the mesh shall be a minimum of 1/2 by 1/2 inch (13 mm by 13 mm). When the trays are in the rack, they shall be separated by a distance of not less than 1-1/2 inches (38 mm) and openings shall be provided in the rack for circulation of the air.

4.1.4.2 Extractor. A centrifugal extractor of the laundry-type with a perforated basket, approximately 11 inches (279 mm) deep by 17 inches (432 mm) in diameter, with an operating speed of approximately 1500 revolutions per minute.

4.1.4.3 Drying oven. A circulating air oven thermostatically controlled and capable of maintaining the temperature at 221° to 230°F (105° to 110°C).

4.2 Reagent.

4.2.1 Detergent. Soap solution conforming to P-S-1792, Soap, Laundry (Neutral and Built), type I, class 1. A stock solution of the soap may be prepared by dissolving 1 pound (500 g) of chip soap in 1 gallon (3.8 liters) of hot water. When cooled, this forms a thick homogeneous jelly which may be used as required.

5. PROCEDURE

5.1 Preparation of specimen.

5.1.1 Woven and warp knitted (single layer) cloth. Three specimens shall be selected from the cloth (sample unit) as follows: 1 specimen from each side of the cloth to within 3 inches (76 mm) of the selvage and 1 specimen from the center of the cloth. No two specimens shall contain the same filling yarns or courses. The specimen shall be laid without tension on a flat surface, care being taken that the cloth is free from wrinkles or creases. Three distances, each a minimum of 18 inches (457 mm) shall be measured and marked off parallel to each of the warp and filling or wale and course directions of the specimen. The distances shall be a minimum of 6 inches (152 mm) apart and at least 1 inch (25 mm) from any edge of the specimen. The distance may be marked with indelible ink and a fine pointed pen, or by sewing fine threads into the cloth, or by a stamping machine. The measured distance shall be parallel to the respective yarns.

5.1.2 Circular and tubular knit cloths. Three distances, each a minimum of 18 inches (457 mm) shall be measured and marked off parallel to the wale directions of the specimen. The distances shall be a minimum of 6 inches (152 mm) apart. Three width measurements shall be made and marked off parallel to the course direction of the specimen. The distances shall be a minimum of 6 inches (152 mm) apart.

5.1.3 Cloth 18 inches (457 mm) and less in width. Three distances, each a minimum of 18 inches (457 mm), shall be measured and marked off parallel to the warp or wale direction. Three width measurements shall be made and marked off along the full width of the cloth parallel to the filling or course direction. The distances shall be a minimum of 6 inches (152 mm) apart.

5.2 Washing. The specimen shall be placed in the wash wheel with sufficient other similar cloth to make up a dry load of $3 \pm 1/4$ pounds (1360 ± 113 g). Start the wash wheel to rotate, and note the time. Immediately add water at a temperature of $100^\circ \pm 9^\circ\text{F}$ ($38^\circ \pm 5^\circ\text{C}$) of not over 50 parts per million hardness to the wash wheel to a level of $7 \pm 1/2$ inches (178 ± 13 mm); this level will be increased by condensed steam. When the water level has been reached, inject steam into the wash wheel until the temperature is between 203° and 212°F (95° and 100°C), and then shut off all steam. Add sufficient soap to furnish a good running suds.

5.2.1 The soap solution shall be drained off 37 minutes after the wash wheel begins to rotate, substantially emptying the wheel of soap and water at the end of 40 minutes from the time the wash wheel was started.

METHOD 5550

5.2.2 The wash wheel shall be immediately refilled to a level of 8-1/2 ± 1/2 inch (216 ± 13 mm) with water at a temperature of 100° ± 9°F (38° ± 5°C). Inject steam until the temperature is 140° to 149°F (60° to 65°C). The water shall be drained off at such a time so that the wheel has become substantially empty of water at the end of 45 minutes from the time the wash wheel was started.

5.2.3 For a third time, the wash wheel shall be immediately refilled to a level of 8-1/2 ± 1/2 inch (216 ± 13 mm) with water at a temperature of 100° ± 9°F (38° ± 5°C). Inject steam until the temperature is 140° to 149°F (60° to 65°C). The water shall be drained off at such a time so that the wheel has become substantially empty of water at the end of 55 minutes from the time the wash wheel was started. The wash wheel shall then be run without further addition of water and shall be stopped at 60 minutes from the time the wheel was started.

5.3 Extraction. The specimen shall be removed from the wash wheel and the excess water removed by extraction for a period of 5 minutes.

5.4 Drying.

5.4.1 Knit cloth. After extraction, the specimen of knit cloth shall be spread out on the drying tray to remove wrinkles, but not distorted, and permitted to dry overnight at room temperature. A current of air from an electric fan may be directed onto the specimen, or the specimen on the drying tray may be placed in the drying oven at a temperature of 221° to 230°F (105° to 110°C) to facilitate drying.

5.4.2 Woven cloth. After extraction, the specimen shall be dried as described in 5.4.1. The dry specimen shall be allowed to cool for 5 minutes, sprinkled with water to permit damp pressing, and allowed to stand in this condition for 5 minutes.

5.4.2.1 When specified in the procurement document, the cloth shall be pressed without drying.

5.5 Pressing.

5.5.1 Knit cloth. Unless otherwise specified in the procurement document, knit cloth shall not be pressed before measuring the shrinkage. When pressing of knit cloth is specified, the specimen shall be pressed as described in 5.5.2.

5.5.2 Woven cloth. The extracted specimen, 5.3, or the dried and dampened specimen, 5.4.2, shall be smoothed to remove wrinkles, but not distorted and shall then be pressed either with a flat-bed press or hand-iron. The head

METHOD 5550

of the press or the hand-iron shall be at a temperature of 275° to 300°F (135° to 149°C) during the pressing operation. When a hand-iron is used, the iron shall not be slid back and forth on the specimen, but simply pressed down upon it in a manner simulating the action of the flat-bed press.

5.6 Evaluation. The specimen shall be laid out without tension on a flat surface in the standard atmosphere until moisture equilibrium is reached. Care shall be taken that the specimen is smooth and free from wrinkles or creases. The previously measured distance marked on the specimen shall again be measured in both the warp and filling or wale and course directions.

5.7 Calculation of results.

5.7.1 The dimensional stability of the specimen shall be calculated as follows:

$$\text{Shrinkage, percent} = \frac{A - B}{A} \times 100$$

Where: A = Average of initial measurements (3 specimens).

B = Average measurements after laundering (3 specimens).

6. REPORT

6.1 The shrinkage of the sample unit in the warp (wale) direction and in the filling (course) direction shall be the average of the specimens tested from each direction, respectively, and shall be reported separately to the nearest 0.1 percent.

6.1.1 When a test result registers elongation rather than shrinkage, each elongation result shall be prefixed with a minus sign with both the minus sign and the value inclosed in parenthesis.

6.2 Each individual value used to calculate the average shall also be reported.

7. NOTES

7.1 A wash wheel of the type described in this method is available from:

Ewing Division of Powercom
P.O. Box 454
Troy, NY 12181

SHRINKAGE IN LAUNDERING; CLOTH OTHER THAN

COTTON AND LINEN

1. SCOPE

1.1 This method is intended for determining the shrinkage of woven cloth containing fibers other than cotton or linen or of mixtures of either cotton or linen and other fibers in a normal laundering procedure. It may be used for determining the shrinkage of other items as specified. The dimensional stability is defined as the change in a measured distance of the material after

2. TEST SPECIMEN

2.1 Woven and warp knitted (single layer) cloth specified in the procurement document, the specimen shall be at least 22 by 22 inches (559 by 559 mm), except for circular cloth (559 mm), when the specimen shall be 22 inches (559 mm) in width of the cloth.

2.2 Cloth 18 inches (457 mm) and less in width. specified in the procurement document, the specimen shall be 18 inches in length and measurements in the width direction shall be across the cloth.

2.3 Circular and tubular knit cloths. Unless otherwise specified in the procurement document, the specimen shall be at least 18 inches in length and the width of the cloth as received.

3. NUMBER OF DETERMINATIONS

3.1 Unless otherwise specified in the procurement document, from each sample unit shall be tested in each of the warp and (course) directions.

4. APPARATUS, REAGENTS AND METHOD CITED

4.1 Apparatus. The apparatus shall conform to that specified in Method 5550.

4.2 Reagent.

METHOD 5552

4.2.1 Detergent. Soap conforming to the requirements of Laundry (Neutral and Built), Type II, Class 1. A solution may be prepared by dissolving 1 pound of chip soap (0.45 kg in 4 L). When cooled, this forms a thick gel that may be used as required.

4.3 Method cited.

Method 5550, Shrinkage in Laundering; Cotton and Linen Cloth.

5. PROCEDURE

5.1 Preparation of specimen.

5.1.1 Woven and warp knitted (single layer) cloth. As specified in the procurement document, 3 specimens shall be cut from the cloth (sample unit) as follows: One specimen shall be cut from the cloth within 3 inches (76 mm) of the selvage and one specimen shall be cut from the center of the cloth. No two specimens shall contain the same warp and filling. The specimen shall be laid without tension on a flat surface. It shall be taken that the cloth is free from wrinkles or creases. Each specimen, which shall be a minimum of 18 inches (457 mm), shall be measured to each of the warp and filling or wale and course directions. The distances shall be a minimum of 6 inches (152 mm) from any edge of the specimen. The distance shall be marked with indelible ink and a fine-pointed pen or by sewing or by stamping. The measured distance shall be parallel to the warp or wale yarns.

5.1.2 Circular and tubular knit cloths. Three specimens, each of 18 inches (457 mm) shall be measured and marked in the length direction of the specimen. The distances shall be 6 inches (152 mm) apart. Three width measurements shall be made and marked in the course direction of the specimen. The distances shall be 6 inches (152 mm) apart.

5.1.3 Cloth 18 inches (457 mm) and less in width. Three specimens, each of a minimum of 18 inches (457 mm) shall be measured and marked in the warp or wale direction. Three width measurements shall be made and marked along the full width of the cloth parallel to the selvage. The distance shall be a minimum of 6 inches (152 mm) from any edge of the specimen.

5.2 Washing. Water at a temperature of 100 ± 1 degrees Celsius shall be added to 50 parts per million hardness shall be added to the water. The specimen shall be washed in a 7 \pm 1/2 inches (178 \pm 13 mm) inside the wheel (cylinder) with suds added to furnish a good running suds. The specimen shall be washed in a wash wheel with other similar cloth to make up a total weight of 1360 \pm 113 g.

METHOD 5552

5.2.1 The wash wheel shall then be started and run for 15 minutes. At the end of the 15 minute period, the machine shall be stopped and the soap solution drained off.

5.2.2 Water at a temperature of $100 \pm 4^{\circ}\text{F}$ ($38^{\circ} \pm 2^{\circ}\text{C}$) shall be again added to the wash wheel to give a depth of $7 \pm 1/2$ inches (178 ± 13 mm) inside the wheel (cage). The wash wheel shall be started and run for a period of 5 minutes, again stopped, and the water drained off.

5.2.3 For a third time, the wash wheel shall be filled with water at a temperature of $100 \pm 4^{\circ}\text{F}$ ($38^{\circ} \pm 2^{\circ}\text{C}$) to give a depth of $7 \pm 1/2$ inches (178 ± 13 mm), and run for an additional 10 minutes. At the end of the 10-minute period, the wash wheel shall be stopped and the water drained off.

5.3 Extraction. The specimen shall be removed from the wash wheel and the excess water removed by extraction for a period of 5 minutes.

5.4 Drying.

5.4.1 Knit cloths. After extraction, specimens of knit cloth shall be spread out on the drying tray to remove wrinkles, but not distorted, and permitted to dry overnight at room temperature. A current of air from an electric fan may be directed onto the specimen, or the specimen on the drying tray may be placed in the drying oven at a temperature of 221° to 230°F (105° to 110°C) to facilitate drying.

5.4.2 Woven cloths. After extraction, the specimen shall be dried as described in 5.4.1. The dry specimen shall be allowed to cool for 5 minutes, sprinkled with water to permit damp pressing, and allowed to stand in this condition for 5 minutes.

5.4.2.1 When specified by the procurement document, the cloth shall be pressed without drying.

5.5 Pressing.

5.5.1 Knit cloths. Unless otherwise specified in the procurement document, knit cloth shall not be pressed before measuring the shrinkage. When pressing of knit cloth is specified in the procurement document, the specimen shall be pressed as described in 5.5.2.

5.5.2 Woven cloth. The extracted specimen (5.3) or the dried and dampened specimen (5.4.2) shall be smoothed to remove wrinkles, but not distorted and then pressed either with a flat-bed press or hand-iron. The head of the press or the hand-iron shall be at a temperature of 275° to 300°F (135° to 149°C) during the pressing operation. When a hand-iron is used, the iron shall not be slid back and forth on the specimen, but simply pressed down upon it in a manner simulating the action of the flatbed press.

METHOD 5552

5.6 Evaluation. The specimen shall be laid out without tension on a flat surface in standard atmosphere until moisture equilibrium is reached. Care shall be taken that the specimen is smooth and free from wrinkles or creases. The previously measured distance marked on the specimen shall again be measured in both the warp and filling or wale and course directions.

5.7 Calculation of results. The dimensional stability of the specimen shall be calculated as follows:

$$\text{Shrinkage, percent} = \frac{A - B}{A} \times 100$$

Where: A = Average of initial measurements (3 specimens).

B = Average measurement after laundering (3 specimens).

6. REPORT

6.1 The shrinkage of the sample unit in the warp (wale) direction and in the filling (course) direction shall be the average of the specimens tested from each direction, respectively, and shall be reported separately to the nearest 0.1 percent.

6.1.1 When a test result registers elongation rather than shrinkage, each elongation result shall be prefixed with a minus sign, with both the minus sign and the value in parenthesis.

6.2 Each individual value used to calculate the average shall also be reported.

METHOD 5554
July 20, 1978

SHRINKAGE IN LAUNDERING: WOOL CLOTH; ACCELERATED METHOD

1. SCOPE

1.1 This method is intended for determining the dimensional stability in the laundering of shrink-resistant wool cloth by means of an accelerated procedure. This method is more severe than Method 5552 and 5556, and is especially useful in determining, by one test, the dimensional stability equivalent to a number of normal launderings. The material may or may not be relaxed prior to this test as required by the procurement document (see relaxation standard Method 5558). The dimensional stability is determined by a change in a measured distance, or the material after subjection to test.

2. TEST SPECIMEN

2.1 Cloths 24 inches (610 mm) or more in width. Unless otherwise specified in the procurement document, the specimen shall be a square of cloth at least 24 inches by 24 inches (610 mm by 610 mm).

2.2 Cloths 18 to 24 inches (457 to 610 mm) in width. Unless otherwise specified in the procurement document, the specimen shall be 24 inches (610 mm) in length and the width of the cloth as received.

2.3 Cloths 18 inches (457 mm) and less in width. Unless otherwise specified in the procurement document, the specimen shall be at least 24 inches (610 mm) in length, and the width of the cloth as received.

3. NUMBER OF DETERMINATIONS

3.1 Unless otherwise specified in the procurement document, three specimens from each sample unit shall be tested in each of the warp and filling directions.

4. APPARATUS, REAGENTS AND METHODS CITED

4.1 Apparatus.

4.1.1 The apparatus shall conform to the requirements as specified in Method 5550. The tumble drier shall be as specified in Method 5556.

4.2 Reagent.

4.2.1 A suitable buffering reagent for buffering the water to a pH of approximately 6.5 to 7.5.

FED. TEST METHOD STD. NO. 191A

METHOD 5554

4.3 Methods cited.

Method 5550, Shrinkage in Laundering; Cotton, Linen, and Blended Cotton and Linen Cloth.

Method 5552, Shrinkage in Laundering; Cloth Other Than Cotton and Linen.

Method 5556, Mobile Laundry Evaluation for Textile Materials.

Method 5558, Shrinkage, Relaxation; Wool Cloth.

5. PROCEDURE

5.1 Preparation of specimen.

5.1.1 Conditioning. All test specimens shall be conditioned under standard atmospheric conditions in accordance with Section 4 of this Standard prior to marking and testing.

5.1.2 Cloths 24 inches (610 mm) or more in width. The 3 specimens shall be selected from the cloth (sample unit) as follows: 1 specimen from each side of the cloth within 3 inches (76 mm) of the selvage, and 1 specimen from the center of the cloth. No two specimens shall contain the same filling yarns. The specimen shall be laid without tension on a flat surface, care being taken that the cloth is free from wrinkles or creases. The edges of the specimen square shall be slit by 1-inch (25 mm) diagonal cuts at intervals of about 6 inches (152 mm). Three distances, each about 18 inches (457 mm), shall be measured and marked off parallel to each of the warp and filling directions of the specimen. The distances shall be a minimum of 6 inches (152 mm) apart and 1 inch (25 mm) from any edge of the specimen. The distances may be marked with indelible ink and a fine-pointed pen, or by sewing fine threads into the cloth, or by stamping machines. The measured distance shall be parallel to the respective yarns.

5.1.3 Cloths 18 to 24 inches (457 to 610 mm) in width. Three distances, each a minimum of 18 inches (457 mm), shall be measured and marked off parallel to the warp and filling directions.

5.1.4 Cloths 18 inches (457 mm) and less in width. Three width measurements shall be made and marked off along the full width of the cloth parallel to the warp and filling direction. The distances shall be a minimum of 6 inches (152 mm) apart.

5.2 Water at a temperature of $140^{\circ} \pm 0.5^{\circ}\text{F}$ ($60^{\circ} \pm 1^{\circ}\text{C}$) and not over 50 parts per million hardness shall be added to the wash wheel to a level of 4 inches (102 mm), or water shall be introduced into the wash wheel to a level of minimum temperature of 91°F (33°C), with steam injected, until a temperature of $140^{\circ} \pm 0.5^{\circ}\text{F}$ ($60^{\circ} \pm 1^{\circ}\text{C}$) is reached. The water shall be brought to a pH of

METHOD 5554

approximately 6.5 to 7.5 using any suitable buffering reagent. The temperature of the water in the washer will be maintained at $140^{\circ} \pm 0.5^{\circ}\text{F}$ ($60^{\circ} \pm 1^{\circ}\text{C}$) during the entire test. The specimen and sufficient wool ballast, of approximately the same weight, cut to specimen size to make a 6-pound (2.7 kg) load, shall be placed in the wash wheel and the wash wheel started. The wash wheel shall be run for a minimum of 1 hour.

5.3 At the end of the laundering period, the specimen shall be extracted for 5 minutes and dried in the tumble dryer at a stack temperature of $129^{\circ} \pm 0.5^{\circ}\text{F}$ ($54^{\circ} \pm 1^{\circ}\text{C}$) for a minimum of 30 minutes.

5.4 After drying, the specimen shall be smoothed to remove wrinkles, but not distorted, and shall then be pressed with either a flat-bed press or hand-iron. The head of the press or the hand-iron shall be at a temperature of 275° to 302°F (135° to 150°C) during the pressing operation. When a hand-iron is used, the iron shall not be slid back and forth on the specimen, but simply pressed down upon it in a manner simulating the action of the flat-bed press.

5.5 Evaluation. The specimen shall be laid out without tension on a flat surface under standard atmospheric conditions in accordance with Section 4 of this Standard until moisture equilibrium is reached. Care should be taken that the specimen is smooth and free from wrinkles or creases. The previously measured distance marked on the specimen shall again be measured in both warp and filling directions.

5.6 Calculation of results. The dimensional stability of the specimen shall be calculated as follows:

$$\text{Shrinkage, percent} = \frac{A - B}{A} \times 100$$

Where: A = Average of initial measurements (3 specimens).

B = Average of measurements after laundering (3 specimens).

6. REPORT

6.1 The shrinkage of the sample unit in the warp direction and in the filling direction shall be the average of the specimens tested from each direction, respectively, and shall be reported to the nearest 0.1 percent.

6.1.1 When a test result registers elongation rather than shrinkage, each elongation result shall be prefixed with a minus sign with both the minus sign and the value enclosed in parenthesis.

METHOD 5554

6.2 Each individual value used to calculate the average shall also be reported.

7. NOTES

7.1 Machines of the type described in this method may be purchased from:

- (a) Ewing Division of Powercom, P.O. Box 454, Troy, NY 12181
- (b) Eastern Equipment Company, 158 Green Street, Boston, MA.

MOBILE LAUNDRY EVALUATION FOR TEXTILE MATERIALS

1. SCOPE

1.1 This method is intended for use where it is desired to reproduce, by means of a laboratory procedure, changes in dimensions of woven or knitted cloth (wool, cotton, synthetics, and blends) and measure the durability or efficiency of functional finishes by two different laundering procedures which simulate field conditions. The title of the procedures, i.e., "wool" and "cotton" are so designated to allow for easy reference in procurement documents. This test method allows for two general temperature ranges of laundering and the end use application and procurement document will determine the laundering procedure to be followed in evaluating the wide range of textile materials to which it is applicable. It also allows for determining the launderability of battings and feathers.

2. TEST SPECIMEN

2.1 Specimens for determining dimensional stability. Unless otherwise specified in the procurement document, the following shall apply:

2.1.1 Woven or warp knitted (single layer) cloth. The specimen shall be a square of cloth 22 inches by 22 inches (559 mm by 559 mm) except for wool cloth, then the specimen shall be 24 inches by 24 inches (610 mm by 610 mm).

2.1.2 Circular and tubular knit cloths. The specimen shall be 22 inches (559 mm) in length and the width of the cloth as received.

2.1.3 Cloths 22 inches (559 mm) and less in width. The specimen shall be at least 22 inches (559 mm) in length and the width of the cloth as received.

2.2 Specimens for evaluating durability and stability of functional finishes. Unless otherwise specified in the procurement document, the following shall apply:

2.2.1 Specimens for evaluating flame resistant finishes. The specimen shall be an 18 inch (457 mm) square of cloth.

2.2.2 Specimens for evaluating water resistant and other functional finishes as specified in the procurement document. The specimen shall be 1 linear yard (0.91 m) full width of the cloth.

2.3 Specimens for determining the launderability of battings. The specimen shall be a 26 inch (660 mm) square of batting prepared as specified in 5.1.

METHOD 5556

2.4 Specimens for determining the launderability of feathers. The specimen shall be 1 ounce (28.4 g) of feathers prepared as specified in 5.1.

3. NUMBER OF DETERMINATIONS

3.1 Dimensional stability. Unless otherwise specified in the procurement document, three specimens from each sample unit shall be tested in each of the warp or wale and filling or course directions.

3.2 Evaluating functional finishes and determining launderability of battings and feathers. The number of cycles of laundering (see 5.2.4) and the specific evaluation criteria shall be as specified in the procurement document. The material encompassed in the sample unit for testing and the number of determinations for each criteria shall be as specified in the procurement document.

4. APPARATUS AND REAGENTS

4.1 Apparatus.

4.1.1 Wash Wheel (see 7.1). A cylindrical wash wheel of the reversing type shall be used. The wheel (cage) shall be 20 to 24 inches (508 to 610 mm) inside diameter and 20 to 24 inches (508 to 610 mm) inside length. There shall be three fins each approximately 3 inches (76 mm) wide extending the full length of the inside of the wheel. One fin shall be located every 120 degrees around the inside diameter of the wheel. The wash wheel shall rotate at a speed of 30 ± 4 revolutions per minute making 5 to 10 revolutions before reversing. The water inlets shall be large enough to permit filling the wheel to an 8 inch (203 mm) level in less than 2 minutes, and the outlet shall be large enough to permit discharge of this same amount of water in less than 2 minutes. The wash wheel shall be equipped with a pipe for injecting live steam that shall be capable of raising the temperature of water at an 8 inch (203 mm) level from 100° to 140°F (38° to 60°C) in less than 2 minutes.

4.1.1.1 The wash wheel shall be equipped with a thermometer or other equivalent equipment for determining the temperature of the water during the washing and rinsing procedures, and with an outside water gage that will indicate the level of the water in the wheel.

4.1.2 Preheating tank or other device. A preheating device to supply water in quantity within $\pm 4^{\circ}\text{F}$ ($\pm 2^{\circ}\text{C}$).

4.1.3 Extractor (see 7.2). A centrifugal extractor of the laundry type with a perforated basket, approximately 11 inches (279 mm) deep by 17 inches (432 mm) in diameter with an operating speed of approximately 1500 revolutions per minute.

4.1.4 Drier (see 7.1). A drier of the rotary, tumble type having a cylindrical basket approximately 36 inches (914 mm) in diameter and 24 inches (610 mm) in length and rotating at 35 ± 2 revolutions per minute. The drier shall be capable of maintaining a minimum stack temperature of 120°F (49°C) during the entire drying cycle of the standard load. The stack temperature shall be measured 20 ± 2 inches (508 \pm 51 mm) from the exhaust opening of the drier.

4.1.5 Pressing equipment. Any flat-bed press capable of pressing a specimen 24 inches (610 mm) square or a hand iron weighing approximately 6 pounds (2.7 kg) may be used as an alternative. The flat-bed press or iron shall be equipped with a temperature control to maintain the temperature between 248° to 305°F (120° to 152°C) (see 7.2).

4.1.6 Measuring scale. Yardstick, meterstick, metal tape or other suitable measuring device graduated in increments of 1/16 inch (1 mm).

4.1.7 Balance. Balance or scale capable of weighing the specimen to an accuracy of ± 0.5 g.

4.2 Reagents.

4.2.1 Synthetic detergent. Synthetic detergent meeting the requirements of MIL-D-43362, Detergent, Laundry (Anionic: A Standard for Testing) (see 7.3).

4.2.2 Sour. Sour conforming to the requirements of P-S-683, Sour, Laundry (Fluoridated) Type I.

4.2.3 Water of not over 50 parts per million hardness.

5. PROCEDURE

5.1 Preparation of specimen. Prior to initial markings for determining dimensional stability and prior to determining the change after laundering, the cloth shall be brought to equilibrium under standard atmospheric conditions as defined in Section 4 of this Standard. When evaluating woolen cloth, the edge shall be slit by diagonal cuts at intervals of about 6 inches (152 mm).

5.1.1 Preparation of specimen for dimensional stability.

5.1.1.1 Woven or warp knitted (single layer) cloth. The three specimens shall be selected from the cloth (sample unit) as follows: One specimen from each side of the cloth to within 3 inches (76 mm) of the selvage and one specimen from the center of the cloth. No two specimens shall contain the same filling yarns or courses. The specimens shall be laid without tension on a flat surface, care being taken that the cloth is free from wrinkles or

METHOD 5556

creases. Three distances, each a minimum of 18 inches (457 mm) shall be measured and marked off parallel to each of the warp and filling or wale and course directions of the specimen. The distance shall be a minimum of 6 inches (152 mm) apart and 1 inch (25 mm) from any edge of the specimen. The distance may be marked with indelible ink and a fine pointed pen, or by sewing fine threads into the cloth, or by a stamping machine. The measured distance shall be parallel to the respective yarns.

5.1.1.2 Circular and tubular knit cloths. Three distances, each a minimum of 18 inches (457 mm) shall be measured and marked off parallel to the wale directions of the specimen. The distances shall be a minimum of 6 inches (152 mm) apart.

5.1.1.3 Cloths 22 inches (559 mm) and less in width. Three distances, each a minimum of 18 inches (457 mm), shall be measured and marked off parallel to the warp or wale direction. Three width measurements shall be made and marked off along the full width of the cloth parallel to the filling or course direction. The distances shall be a minimum of 6 inches (152 mm) apart.

5.1.2 Preparation of specimen for laundering of batting. The 26 inch (660 mm) square of batting shall be sewn between two pieces of cotton balloon cloth conforming to MIL-C-332, type I, class 2. The bonded batting shall be placed between the two pieces of balloon cloth with the warp direction of the cloth coinciding with the length direction of the batting. The assembly shall be completely stitched on all four sides approximately 1 inch (25 mm) in from the outer edges. In addition, the assembly shall be stitched at 6 inch (152 mm) intervals in the warp direction yielding 4 channels in the test specimen.

5.1.3 Preparation of specimen for laundering of feathers. The one ounce (28.4 g) specimen of feathers shall be sewn in a 17 by 6 inch (432 by 152 mm) cotton balloon cloth bag conforming to MIL-C-332, type I, class 2. Care shall be taken in constructing the bag to insure that seams are tight and strong to prevent loss of feather material.

5.2 The procedure to be followed, i.e., cotton or wool, shall be specified in the end item specification or procurement document.

5.2.1 Standard loads. Unless otherwise specified in the procurement document, the following standard loads comprising the specimen under test and clean ballast of comparable size, weight and type of cloth shall be utilized.

5.2.1.1 Cotton laundering procedure. A total weight of 20 pounds (9.1 kg) consisting of specimen and ballast.

5.2.1.1.1 Cotton laundering procedure when evaluating flame resistant finishes. Twenty-four 18 inch (457 mm) squares of cloth consisting of specimen and ballast.

METHOD 5556

5.2.1.2 Wool laundering procedure. A total weight of 20 pounds (9.1 kg) consisting of specimen and ballast.

5.2.2 Cotton laundering procedure. Water of not over 50 parts per million hardness at the required temperature $\pm 4^{\circ}\text{F}$ ($\pm 2^{\circ}\text{C}$) shall be introduced into the wash wheel to the designated level. The schedule of table I shall be followed. At the end of each time interval, the machine shall be stopped, drained without removing the load and refilled to the proper level before starting again. The wheel shall be in motion a total of 22 minutes during the period of testing. After laundering, the standard load shall be extracted in two equivalent portions, a minimum of 3 minutes each. The specimens shall be separated, opened to full width and dried together with the ballast at 180° to 210°F (82° to 99°C) for 45 to 60 minutes in a rotating tumble drier.

TABLE I. Cotton laundering schedule (see 7.4)

Operation	Composition	Water Level inches (mm)	Temperature $^{\circ}\text{F}$ ($^{\circ}\text{C}$)	Time (Minutes)
1. Suds	Synthetic detergent (25 g)	6 (152 mm)	100 (38)	5
2. Suds	Synthetic detergent (15 g)	4 (102 mm)	140 (60)	5
3. Rinse		8 (203 mm)	140 (60)	3
4. Rinse		8 (203 mm)	120 (49)	3
5. Rinse	Sour (24 g)	8 (203 mm)	100 (38)	3
6. Rinse		8 (203 mm)	100 (38)	3
				22

5.2.3 Wool laundering procedure. Water of not over 50 parts per million hardness at the required temperature $\pm 4^{\circ}\text{F}$ ($\pm 2^{\circ}\text{C}$) shall be introduced into the wash wheel to the designated level. The schedule of Table II shall be followed. At the end of each operation, the machine shall be stopped, drained without removing the load, and refilled to the required level before starting again. At the beginning of the fifth operation, water shall be admitted into the wash wheel to a level of 8 inches (203 mm), the laundry sour added in the quantity required, and the machine run 4 minutes before stopping and draining. After laundering, the standard load shall be extracted in two equivalent portions for five minutes each. The specimens shall be separated, opened to full width and dried together with the ballast at a stack temperature of 130° to 180°F (54° to 82°C) for 30 to 45 minutes.

TABLE 11. Wool laundering schedule (see 7.4)

Operation	Compostion	Water Level inches (mm)	Temperature °F (°C)	Time (Minutes)
1. Suds	Synthetic detergent (25 g)	7 (178 mm)	100 (38)	5
2. Suds	Synthetic detergent (15 g)	7 (178 mm)	100 (38)	5
3. Rinse		8 (203 mm)	100 (38)	3
4. Rinse		8 (203 mm)	100 (38)	3
5. Rinse	Sour (24 g)	8 (203 mm)	100 (38)	4
				20

5.2.4 Laundering cycles. When the requirement in the end item specification or procurement document requires more than one laundering, the complete cycle of washing, extraction, and drying shall be performed the number of times specified. Pressing need only be performed once.

5.3 Pressing.

5.3.1 Pressing of cloths for dimensional stability. The dry specimen shall be allowed to cool a minimum of 5 minutes and shall then be sufficiently moistened with water to allow good pressing. This wetting of the specimen shall be accomplished by a spray nozzle set for fine mist or by applying wet cotton cloths weighing 6 to 8 ounces per square yard (203 to 271 g/m) and having wet pickup of 90 to 100 percent applied to the face and back of the cloth and allowed to stand in contact approximately 2 hours. If necessary, a platen weighing not more than two times the weight of the cloth area covered, may be used to apply a moderate pressure against the cloth to permit transfer of the moisture from the applied cloths to the specimen. The specimen shall be permitted to remain in this condition for 5 minutes, smoothed to remove wrinkles but not distorted, and then pressed either with a flat-bed press or hand-iron. The head of the press or the hand-iron shall be set at a temperature of 248° to 302°F (120° to 150°C).

5.3.2 When a hand-iron is used, the iron shall not be slid back and forth on the specimen, but simply pressed down upon it in a manner simulating the action of a flat-bed press.

5.3.3 Unless otherwise specified in the procurement document, knitted cloths and functionally finished cloths other than those for shrink-resistant testing, battings, and feathers, shall not be moistened or pressed.

5.4 Evaluation.

5.4.1 Evaluation of cloth for dimensional stability. The specimen shall be laid out without tension on a flat surface in the standard atmosphere until moisture equilibrium is reached. Care shall be taken that the specimen is smooth and free from wrinkles or creases. The previously measured distance marked on the specimen shall again be measured in both the warp or wale and filling or course direction.

5.4.2 Evaluation of functional finishes, battings, and feathers. The criteria employed in evaluating functional finishes shall be as specified in the applicable end item specification or procurement document.

5.5 Calculation of results. The dimensional stability of the specimen shall be calculated as follows:

$$\text{Shrinkage, percent} = \frac{A - B}{A} \times 100$$

Where: A = average of initial measurements (3 specimens).

B = average of measurements after laundering (3 specimens).

6. REPORT

6.1 Dimensional stability.

6.1.1 The shrinkage of the sample unit in the warp or wale direction and in the filling or course direction shall be the average of the specimens tested from each direction, respectively, and shall be reported separately to the nearest 0.1 percent.

6.1.1.1 When a test result registers elongation rather than shrinkage, each elongation result shall be prefixed with a minus sign with both the minus sign and the value inclosed in parenthesis.

6.2 Durability or stability of functional finishes.

6.2.1 Reporting the results in the evaluation of functional finishes shall be as specified in the applicable end item specification or procurement document.

6.3 Laundryability of battings and feathers. The reporting of results in the evaluation of laundryability of battings and feathers shall be as specified in the applicable end item specification or procurement document.

6.4 Each individual value used to calculate the average shall also be reported.

METHOD 5556

7. NOTES

7.1 The wash wheel and drier as described may be obtained from Ewing Division of Powercom, P.O. Box 454, Troy, NY 12181.

7.2 The pressing equipment and extractor may be obtained from Ewing Division of Powercom, P.O. Box 454, Troy, NY 12181; American Laundry Machinery Company 5050 Section Avenue, Cincinnati, OH 45212 and Troy Laundry Machinery, East Moline, IL 61244.

7.3 Synthetic Laundering Detergent (under the name of Igepon T-73) may be obtained from GAF Corporation, Dyestuff & Chemical Division, 140 West 51st Street, New York, NY 10020.

7.4 The water levels shown in the tables are based on a wash wheel with 24 inch (610 mm) inside diameter and 24 inch (610 mm) inside length. The following table shows the volumes of liquids corresponding to these water levels:

TABLE III

Water Level in the Wash Wheel		Volume	
<u>Inches</u>	<u>(mm)</u>	<u>Gallons</u>	<u>(L)</u>
4	(102)	903	(35)
6	(152)	14.3	(54)
7	(178)	17.5	(66)
8	(203)	20.5	(77.6)
10	(254)	26.2	(99)

SHRINKAGE, RELAXATION; WOOL CLOTH

1. SCOPE

1.1 This method is intended for determining the relaxation dimensional stability of woven and knitted woolen cloths. The dimensional stability is determined by a change in a measured distance of the material after subjection to test.

2. TEST SPECIMEN

2.1 Woven woolen cloths. Unless otherwise specified in the procurement document, the specimen shall be a square of cloth 24 by 24 inches (610 mm by 610 mm) and the edges shall be slit by 1-inch (25 mm) diagonal cuts at intervals of 6 inches (152 mm). For cloth narrower than 24 inches (610 mm), the specimen shall be 24 inches (610 mm) long and the entire width of the cloth.

2.2 Knitted woolen cloth (other than circular knit). Unless otherwise specified in the procurement document, the specimen shall be as described above, except that the square of cloth shall be 22 by 22 inches (559 by 559 mm) and without any diagonal cuts.

2.3 Circular and tubular knit cloths. Unless otherwise specified in the procurement document, the specimen shall be 22 inches (559 mm) in length and the width of the tubular cloth as received.

2.4 Cloth 18 inches (457 mm) and less in width. Unless otherwise specified in the procurement document, the specimen shall be 22 inches (559 mm) in length and the full width of the cloth as received.

3. NUMBER OF DETERMINATIONS

3.1 Unless otherwise specified in the procurement document, three specimens from each sample unit shall be tested in each of the warp (wale) and filling (course) directions.

4. APPARATUS

4.1 Sink or similar apparatus. The sink must be of such shape and size as to allow the specimens to be laid without folding.

4.2 Extractor. A centrifugal extractor of the laundry type with a perforated basket, approximately 11 inches (279 mm) deep by 17 inches (432 mm) in diameter, with an operating speed of approximately 1,500 revolutions per minute (see 7.1).

METHOD 5558

4.3 Drier. A drier of the rotary, tumble type having a cylindrical basket approximately 36 inches (914 mm) in diameter and 24 inches (610 mm) in length and rotating at 35 ± 2 revolutions per minute. The drier shall be provided with means of maintaining a minimum stack temperature of $130^\circ \pm 2^\circ\text{F}$ ($54^\circ \pm 1^\circ\text{C}$). The stack temperature shall be measured 20 ± 2 inches (508 \pm 51 mm) from the exhaust opening of the drier (see 7.1).

4.4 Pressing equipment. A flat-bed press measuring 24 inches (610 mm) by 50 inches (1270 mm) or larger. Any flat-bed press capable of pressing a specimen 24 inches (610 mm) square or a hand-iron weighing approximately 6 pounds (2.7 kg) may be used as an alternative. The flat-bed press or iron shall be equipped with a temperature control to maintain the temperature between 248° and 302°F (120° to 152°C) (see 7.1).

4.5 Measuring scale. Yardstick, meterstick, metal tape or other suitable measuring device graduated in increments of 1/16 inch (1 mm).

5. PROCEDURE

5.1 Preparation of specimen.

5.1.1 Woven and knitted woolen cloths (other than circular knits). The 3 specimens shall be selected from the cloth (sample unit) as follows. 1 specimen from each side of the cloth to within 3 inches (76 mm) of the selvage and 1 specimen from the center of the cloth. No 2 specimens shall contain the same filling yarns or courses. The specimen shall be laid without tension on a flat surface, care being taken that the cloth is free from wrinkles or creases. Three distances, each a minimum of 18 inches (457 mm), shall be measured and marked off parallel to each of the warp and filling or wale and course directions of the specimen. The distances shall be a minimum of 6 inches (152 mm) apart and 1 inch (25 mm) from any edge of the specimen. The distance may be marked with indelible ink and a fine pointed pen, or by sewing fine threads into the cloth or by a stamping machine. The measured distance shall be parallel to the respective yarns.

5.1.2 Circular and tubular knit cloths. Three distances, each a minimum of 18 inches (457 mm) shall be measured and marked off parallel to the wale direction of the specimen. The distances shall be a minimum of 6 inches (152 mm) apart. Three width measurements shall be made and marked off parallel to the course direction of the specimen. The distances shall be a minimum of 6 inches (152 mm) apart.

5.1.3 Cloths 18 inches (457 mm) and less in width. Three distances, each a minimum of 18 inches (457 mm), shall be measured and marked off parallel to the warp or wale direction. Three width measurements shall be made and marked off along the full width of the cloth parallel to the filling or course direction. The distances shall be a minimum of 6 inches (152 mm) apart.

METHOD 5558

5.2 Water at a temperature of $80^{\circ} \pm 2^{\circ}\text{F}$ ($27^{\circ} \pm 1^{\circ}\text{C}$) and not over 50 parts per million hardness shall be added to the sink in sufficient quantity to allow the specimen to be submerged. The specimen shall be placed in the water and kept submerged for a minimum of 2 hours without agitation. Each specimen shall be placed in the water separately and care taken that each specimen is wet-out when submerged.

5.3 At the end of the 2-hour period, the specimen shall be placed in the extractor for 5 minutes and then dried in the tumble drier at a stack temperature of $130^{\circ} \pm 2^{\circ}\text{F}$ ($54^{\circ} \pm 1^{\circ}\text{C}$) for 30 minutes.

5.4 Pressing.

5.4.1 Woven and knitted woolen fabrics. After drying, the specimen shall be smoothed to remove wrinkles, but not distorted and shall then be pressed either with a flat-bed press or hand-iron. The head of the press or hand-iron shall be at a temperature of 248° to 302°F (120° to 150°C) during the pressing operation. When a hand-iron is used, the iron shall not be slid back and forth on the specimen, but simply pressed down upon it in a manner simulating the action of the flat-bed press.

5.5 Evaluation. The specimen shall be laid out without tension on a flat surface in the standard atmosphere until moisture equilibrium is reached. Care shall be taken that the specimen is smooth and free from wrinkles or creases. The previously measured distance marked on the specimen shall again be measured in both the warp and filling or wale and course directions.

5.6 Calculation of results. The dimensional stability of the specimen shall be calculated as follows:

$$\text{Shrinkage, percent} = \frac{A - B}{A} \times 100$$

Where: A = Average of initial measurements (3 specimens).

B = Average of measurements after laundering (3 specimens).

6. REPORT

6.1 The shrinkage of the sample unit in the warp (wale) and filling (course) directions shall be the average of the specimens tested from each direction, respectively and shall be reported separately to the nearest 0.1 percent.

METHOD 5558

6.1.1 When a test result registers elongation rather than shrinkage, each elongation result shall be prefixed with a minus sign with both the minus sign and the value inclosed in parenthesis.

6.2 Each individual value used to calculate the average shall also be reported.

7. NOTES

7.1 The extractor drier and pressing equipment described in this method may be purchased from: The American Laundry Machinery Company, 5050 Section Avenue, Cincinnati, OH 45212; Ewing Division of Powercom, P.O. Box 454, Troy, NY 12181; Eastern Equipment Company, 158 Green Street, Boston, MA 02130.

SHRINKAGE IN DRY CLEANING; CLOTH

1. SCOPE

1.1 This method is intended for determining the dimensional stability of woven cloth when dry cleaned. It may be used for some knitted cloths or other items as specified in the procurement document. The dimensional stability is determined by a change in a measured distance of the material after subjection to test.

2. TEST SPECIMEN

2.1 The specimen shall be a square of cloth 12 inches by 12 inches (305 mm by 305 mm).

3. NUMBER OF DETERMINATIONS

3.1 Unless otherwise specified in the procurement document, three specimens from each sample unit shall be tested in each of the warp (wale) and filling (course) directions.

4. APPARATUS AND REAGENTS

4.1 Apparatus.

4.1.1 Tumble jar. A tumble jar, (as shown in figure 5500A) cylindrical in shape with approximate dimensions being 12 inches (305 mm) in height and 6 inches (152 mm) in diameter (or between opposite flat faces) with a capacity of approximately 1.6 gallons (6 L) for use in dry cleaning processes. The jar shall be of glass, corrosion-resistant metal or chemical stoneware. The jar shall be mounted in a vertical position in such a manner that it can be rotated around the horizontal axis passing through the center of the jar. Means shall be provided for rotating the jar around the axis at a speed of 55 ± 2 revolutions per minute. The jar shall be clean and thoroughly rinsed so that it is free from soap, detergent, and wetting agents (see 7.1).

4.1.2 Extractor. A centrifugal extractor of the laundry type with a perforated basket, approximately 11 inches (279 mm) deep by 17 inches (432 mm) in diameter, with an operating speed of approximately 1500 revolutions per minute (see 7.1).

4.1.3 Measuring scale. Yardstick, meterstick, metal tape or other suitable measuring device graduated in increments of 1/16 inch (1 mm).

METHOD 5580

4.1.4 Pressing Equipment. A flat-bed press capable of pressing a specimen 10 inches (254 mm) square or a hand-iron weighing approximately 6 pounds (2.7 kg) may be used as an alternative. The flat-bed press or iron shall be equipped with a temperature control apparatus to maintain the temperature between 275° and 300°F (135° and 149°C) (see 7.1).

4.1.5 Drying equipment (see 7.1).

4.1.5.1 Rack and drying trays. The rack and trays shall be of any convenient size over 12 inches by 12 inches (305 mm by 305 mm). The bottoms of the trays shall be a wire mesh, and the size of the mesh shall be a minimum of 1/2 inch by 1/2 inch (13 by 13 mm). When the trays are in the rack, they shall be separated by a distance of not less than 1-1/2 inches (38 mm). Openings shall be provided in the rack for the circulation of the air.

4.1.5.2 Drying oven. A circulating air oven thermostatically controlled and capable of maintaining the temperature at 221° to 230°F (105° to 110°C).

4.1.6 Steam board or table (for pile fabrics only). The steam board or table top shall be metal, well-padded with cotton or other absorbent material. The metal board or table top shall contain perforations of such a size and so spaced as to permit an even dispersion of steam through the padding.

4.2 Reagents.

4.2.1 Dry cleaning agent. The dry cleaning agent shall be Stoddard Solvent meeting the requirements of P-D-680, Dry Cleaning Solvent, Type I.

4.2.2 Dry cleaning soap. Dry cleaning soap is prepared by dissolving 35 g of potassium hydroxide in 89 ml of distilled water. The potassium hydroxide solution shall be poured slowly with constant stirring into a mixture of 250 ml of oleic acid, 724 ml of Stoddard Solvent and 105 ml of cyclohexanol.

4.2.3 Distilled water.

5. PROCEDURE

5.1 Preparation of specimen. The specimen shall be laid without tension on a flat surface, care being taken that the cloth is free from wrinkles or creases. A square of cloth 10 inches by 10 inches (254 by 254 mm), whose sides are parallel with the warp and filling directions of the cloth, respectively, shall be measured and marked off on the specimen. The corners and midpoints of each side of the square may be marked with indelible ink and a fine-pointed pen or by sewing fine threads into the cloth. The specimen shall not be taken nearer the selvage than one-tenth the width of the material.

METHOD 5580

5.2 Dry cleaning. The test specimen and a sufficient quantity of other cloth similar in weight to make a dry load of 240 g shall be placed in the jar and unless otherwise specified in the procurement document, 2 L of the dry cleaning agent containing 145 ml of dry cleaning soap specified-in 4.2.2, shall be added. The tumble jar shall be operated for a period of 25 to 27 minutes. The tumble jar shall be stopped and the cleaning solution poured out. The jar shall be filled one-third full with fresh dry cleaning agent (without dry cleaning soap) and the tumble jar shall be run for an additional 5 minute period, stopped, and the cleaning solution poured out. The procedure described in the preceding sentence shall be repeated 3 times (the total time for operating the tumble jar is 45 minutes).

5.3 Drying. At the end of the dry cleaning period, the specimen shall be removed from the jar. The excess cleaning agent shall be removed from the specimen by a convenient means (which will not distort the sample), such as passing through squeeze rolls, rolling between two layers of turkish toweling, or gently pressing between 2 layers of blotting paper. The specimen shall then be laid on the drying tray and dried at room temperature or the specimen on the drying tray may be placed in hot circulating air at a temperature of 221° to 230°F (105 to 110°C) to facilitate drying.

5.4 Pressing.

5.4.1 Pile cloth. When all of the solvent has evaporated, the specimen shall be laid, pile side down, on the steam board or table and pressed as described in 5.4.2. After the specimen has been pressed, steam shall be turned on and allowed to pass through the specimen for 2 minutes.

5.4.2 Cloth other than pile cloth. When all of the solvent has evaporated, the specimen shall be laid on a padded ironing board, care being taken to avoid any strain or distortion in handling. The specimen shall be covered with a damp press cloth which has been saturated with water and wrung out so as to retain a moisture content equal to or approximately 75 percent of its dry weight. The weight of the press cloth when dry should be between 4 and 5 ounces per square yard (136 and 170 g/m²). The head of the press or the hand-iron shall be at a temperature of 275° to 300°F (135° to 149°C) during the pressing operation. When a hand-iron is used, the iron shall not be slid back and forth on the specimen, but simply pressed down upon it, in a manner simulating the action of the flat-bed press. After pressing, the specimen shall be allowed to lie on a smooth surface for one hour at room temperature and then conditioned overnight.

5.5 Evaluation. Care shall be taken that the specimen is smooth and free from wrinkles or creases. The previously measured distance marked on the specimen shall again be measured in both the warp and filling or wale and course directions.

METHOD 5580

5.6 Calculation of results. The dimensional stability of the specimen shall be calculated as follows:

$$\text{Shrinkage, percent} = \frac{A - B}{A} \times 100$$

Where: A = average of initial measurements (3 specimens)

B = average measurement after dry cleaning (3 specimens).

6. REPORT

6.1 The shrinkage of the sample unit in the warp (wale) directions and the filling (course) direction shall be the average of the specimens tested from each direction, respectively, and shall be reported separately to the nearest 0.1 percent.

6.1.1 When the test result registers elongation rather than shrinkage, each elongation result shall be prefixed with a minus sign with both the minus sign and the value enclosed in parenthesis.

6.2 Each individual value used to calculate the average shall also be reported.

7. NOTES

7.1 The extractor, pressing and drying equipment of the type described in this method may be purchased from the American Laundry Machinery Company, 5050 Section Avenue, Cincinnati, OH 45212; Ewing Division of Powercom, P. O. Box 454, Troy, NY 12181; the tumble jar and the tumbler are available from the Andrews Technical Supply Co., 2540 Eastwood Ave., Eastwood Ave., Evanston, IL 60204.

METHOD 5590
July 20, 1978

SHRINKAGE IN SPONGING; WOOL CLOTH

1. SCOPE

1.1 This method is intended for determining the shrinkage in sponging of wool and wool-blend fabrics. It is less severe than laundering methods. Shrinkage in sponging is the change in measured distances due to sponging.

2. TEST SPECIMEN

2.1 Woven and warp knitted (single layer) cloth. Unless otherwise specified, the specimen shall be a square of cloth 22 by 22 inches (559 by 559 mm), except for cloth narrower than 22 inches (559 mm), then the specimen shall be 22 inches (559 mm) long and the entire width of the cloth.

2.2 Circular and tubular knit goods. Unless otherwise specified, the specimen shall be at least 22 inches (559 mm) in length and the width of the cloth as received.

3. NUMBER OF DETERMINATIONS

3.1 Unless otherwise specified in the procurement document, three specimens from each sample unit shall be tested in each of the warp (wale) and filling (course) directions.

4. APPARATUS AND REAGENT

4.1 Apparatus.

4.1.1 Sink, washwheel, or similar apparatus of such shape and size as to allow the specimen to be laid flat and soaked without folding.

4.1.2 Extractor. A centrifugal extractor of the laundry-type with a perforated basket, approximately 11 inches (279 mm) deep by 17 inches (432 mm) in diameter, with an operating speed of approximately 1500 revolutions per minute. In the absence of an extractor the excess water may be removed by wrapping the cloth in a clean white towel or similar cloth and squeezing between the hands. Wringing by hand or the use of a squeeze roll is not permitted (see 7.1).

4.1.3 Drying equipment (see 7.1).

4.1.3.1 Rack and drying trays. The rack and trays shall be of any convenient size over 22 by 22 inches (559 by 559 mm). The bottoms of the trays shall be a wire mesh, and the size of the mesh shall be a minimum of 1/2 by 1/2 inch (13 by 13 mm). When the trays are in the rack, they shall be separated by a distance of not less than 1-1/2 inches (38 mm). Openings shall be provided in the rack for circulation of the air.

METHOD 5590

4.1.3.2 Drying oven. A circulating air oven thermostatically controlled and capable of maintaining the temperature at 221° to 230°F (105° to 110°C).

4.1.4 Pressing equipment (see 7.1).

4.1.4.1 Flatbed press. A flatbed press with steam pressure of 60 to 80 pounds per square inch (413 to 551 kPa) capable of pressing a specimen 22 inches (559 mm) square.

4.1.4.2 Hand iron. A hand iron weighing approximately 6 pounds (2.7 kg) equipped with a temperature control to maintain the temperature between 248° and 302°F (120° and 150°C).

4.1.5 Measuring scale. Yardstick, meterstick, metal tape or other suitable measuring device graduated in increments of 1/16 inch (1 mm).

4.2 Reagent.

4.2.1 Wetting agent. A wetting agent such as the dioctyl ester of sodium sulfosuccinic acid (Deceresol OT, Aerosol OT) or equivalent.

5. PROCEDURE

5.1 Preparation of specimen.

5.1.1 Woven and warp knitted (single layer) cloth. The three specimens shall be selected from the cloth (sample unit) as follows: one specimen from each side of the cloth to within 3 inches (76 mm) of the selvage and 1 specimen from the center of the cloth. No two specimens shall contain the same filling yarns or courses. The specimen shall be laid without tension on a flat surface, care being taken that the cloth is free from wrinkles or creases. Three distances, each a minimum of 18 inches (457 mm) shall be measured and marked off parallel to each of the warp and filling or wale and course directions of the specimen. The distances shall be a minimum of 6 inches (152 mm) apart and at least 1 inch (25 mm) from any edge of the specimen. The distance may be marked with indelible ink and a fine pointed pen, or by sewing fine threads into the cloth, or by a stamping machine. The measuring distance shall be parallel to the respective yarns.

5.1.2 Circular and tubular knit cloths. Three distances each a minimum of 18 inches (457 mm) shall be measured and marked off parallel to the wale direction of the specimen. The distances shall be a minimum of 6 inches (152 mm) apart. Three width measurements shall be made and marked off parallel to the course direction of the specimen. The distances shall be a minimum of 6 inches (152 mm) apart.

FED. TEST METHOD STD NO. 191A

METHOD 5590

5.1.3 Cloth 18 inches (457 mm) and less in width. Three distances, each a minimum of 18 inches (457 mm), shall be measured and marked off parallel to the warp or wale direction. Three width measurements shall be made and marked off along the full width of the cloth parallel to the filling or course direction. The distances shall be a minimum of 6 inches (152 mm) apart.

5.2 Wetting-out. Water containing 0.03 percent by volume of active ingredient of the wetting agent shall be added to the container in sufficient quantity to completely cover the specimen. A solution composed of 22 gallons (83.3 L) of water plus 100 ml of 25 percent concentrated "Deceresol OT" has been found suitable for wetting-out 6 pounds (2.7 kg) of material. The water shall be at a temperature of 75° to 85°F (24° to 29°C) and shall have not over 50 parts-per-million hardness. The specimen shall be placed in the water and kept submerged without agitation for a period of 60 minutes ± 1 minute. Each specimen shall be separately laid flat in the water without folding. Care shall be taken to see that each specimen is wet-out.

5.3 Extraction. The specimen shall be removed from the container and the excess water removed by extraction for a period of 5 minutes.

5.4 Drying. After extraction, the specimen shall be spread out on the drying tray to remove wrinkles, but not distorted, and permitted to dry overnight at room temperature. A current of air from an electric fan may be directed onto the specimen, or the specimen on the drying tray may be placed in the drying oven at a temperature of 221° to 230°F (105° to 110°C) to facilitate drying.

5.4.1 When specified by the procurement document, the cloth shall be pressed without drying.

5.5 Pressing. The specimen shall be pressed with either a flatbed press or a hand iron specified in 4.1.4.

5.5.1 Flatbed press. The specimen shall be spread out on the bed of the press and the steam valve opened until the steam first appears over the surface of the bed. The head shall then be lowered and vacuum applied for 5 seconds. Drying of the specimen shall be completed by raising the head and applying vacuum until the cloth is cool and dry (about 5 seconds). When the material undergoing test contains more than 20 percent man made fibers, flatbed pressing is preferred to iron pressing.

5.5.2 Hand iron. The dried specimen shall be allowed to cool at least 5 minutes and then moistened sufficiently with water to allow good pressing. The specimen shall be permitted to remain in this condition for 5 minutes. The specimen shall be smoothed to remove wrinkles but not distorted, and then pressed with a hand iron. The head of the hand iron shall be at a temperature of 248° to 302°F (120° to 150°C). The iron shall not be slid back and forth on the specimen, but simply pressed down upon it in a manner simulating the action of a flatbed press.

METHOD 5590

5.6 Evaluation. The specimen shall be laid out without tension on a flat surface in the standard atmosphere until moisture equilibrium is reached. Care shall be taken that the specimen is smooth and free from wrinkles or creases. The previously measured distance marked on the specimen shall again be measured in both the warp and filling or wale and course directions.

5.7 Calculation of results. Shrinkage of the specimen shall be calculated as follows:

$$\text{Shrinkage, percent} = \frac{A - B}{A} \times 100$$

Where: A = Average of initial measurements (3 specimens).

B = Average measurements after laundering (3 specimens).

6. REPORT

6.1 The shrinkage of the sample unit in the warp (wale) direction and in the filling (course) direction shall be the average of the specimens tested from each direction, respectively, and shall be reported separately to the nearest 0.1 percent.

6.1.1 When a test result registers elongation rather than shrinkage, each elongation result shall be prefixed with a minus sign with both the minus sign and the value inclosed in parenthesis.

6.2 Each individual value used to calculate the average shall also be reported.

7. NOTES

7.1 The extractor, drying and pressing equipment of the type described in this method may be purchased from the American Laundry Machinery Company, 5050 Section Ave., Cincinnati, OH 45212; Ewing Division of Powercom, P.O. Box 454, Troy, NY 12181.

METHOD 5600
July 20, 1978

COLORFASTNESS OF TEXTILE MATERIALS TO CHLORINE BLEACHING

1. SCOPE

1.1 This method is intended for determining the colorfastness of textile materials to chlorine bleaching.

2. TEST SPECIMEN

2.1 Standard sample. Unless otherwise specified in the procurement document, when a standard sample has been established, the required specimens from the sample unit of the material to be tested and one specimen from the standard sample shall be as follows:

2.1.1 Cloth. Two to six grams of cloth.

2.1.2 Yarn, thread, light cordage, tape, webbing and braid. Two to six grams of the applicable material, so held together to form a unit for testing.

2.2 No standard sample. Unless otherwise specified in the procurement document, when a standard sample has not been established, the required specimens from the sample unit of the material to be tested, shall be as specified in 2.1.1 or 2.1.2. One additional specimen shall be taken from each sample unit of the material to be tested and shall be retained, untested, for comparison. All specimens shall be taken from adjacent areas of the sample unit.

3. NUMBER OF DETERMINATIONS

3.1 Unless otherwise specified in the procurement document, one specimen shall be tested from each sample unit.

4. APPARATUS, REAGENTS AND METHOD CITED

4.1 Apparatus.

4.1.1 Launder-Ometer. Launder-Ometer or similar machine having a metal adapter in which tightly capped stainless steel cylindrical containers 5 inches (127 mm) in length by 3 inches (76 mm) in diameter are held with their bases toward a horizontal shaft 2 inches (51 mm) from the center of rotation. The shaft shall rotate at a speed of 40 to 45 rpm. Each container shall be equipped with a sealing device having solvent resistant rings.

FED. TEST METHOD STD. NO. 191A

METHOD 5600

An equal number of stainless steel containers shall be fastened on opposite sides of the rotating shaft in order to maintain balanced and smooth rotation during the test. The Launder-Ometer or similar machine shall be maintained at a temperature of $90^{\circ} \pm 4^{\circ}\text{F}$ ($32^{\circ} \pm 2^{\circ}\text{C}$) (see 7.1).

4.1.2 Pressing equipment.

4.1.2.1 Steam press. Flat-bed press maintained at a temperature of 275° to 302°F (135° to 150°C).

4.1.2.2 Hand-iron. A hand-iron weighing approximately 6 pounds (2.7 kg) and maintained at a temperature of 275° to 302°F (135° to 150°C).

4.1.3 Extractor. A centrifugal extractor of the laundry type with a perforated basket approximately 11 inches (280 mm) deep by 17 inches (432 mm) in diameter with an operating speed of approximately 1500 rpm.

4.1.4 Oven. A circulating-air oven capable of maintaining the required temperature within $\pm 4^{\circ}\text{F}$ ($\pm 2^{\circ}\text{C}$).

4.1.5 Bleached, desized, cotton cloth (see 7.2).

4.2 Reagents.

4.2.1 Distilled water.

4.2.2 Sodium hypochlorite solution (bleach). Any commercial preparation of sodium hypochlorite (NaOCl - bleach solution - 4 percent to 6 Percent available chlorine) diluted with distilled water to an available chlorine content of 0.3 percent and adjusted to a hydrogen ion content (pH) of 11.0 ± 0.2 , with a buffer solution specified in 4.2.3.

4.2.3. Buffer solution. The buffer solution needed to adjust the pH to the required level shall be as follows:

4.2.3.1 Five parts of 1 percent solution of sodium bicarbonate (NaHCO_3) and 95 parts of 5 percent solution of sodium carbonate (Na_2CO_3). Both solutions shall be prepared with distilled water.

4.2.3.2 Ten percent solution of sodium hydroxide (NaOH).

4.2.4 Soap solution. Soap solution containing 0.5 percent soap, P-S-1792, Soap, Laundry (Neutral and Built), type I, classes 1 or 2 for use when the specimen has a water repellent finish.

METHOD 5600

4.2.5 Antichlor. Sodium bisulfite solution (antichlor) prepared by dissolving 5 grams of sodium bisulfite (NaHSO_3) anhydrous, C.P. in 1000 ml of distilled water.

4.2.6 Acetic acid solution. 0.14 g of glacial acetic acid, C.P. diluted to 1000 ml.

4.3 Method cited.

Method 9010, Shade Matching of Textile Materials; Visual Method.

5. PROCEDURE

5.1 Standard sample. When a standard sample has been established, one specimen of the standard sample shall be bleached at the same time and under the same conditions as the specimen of the material being tested.

5.2 No standard sample. When a standard sample has not been established one specimen from the sample unit being tested shall be retained, untested, for comparison.

5.3 The specimen shall be wet thoroughly with distilled water at a temperature of $90 \pm 4^\circ\text{F}$ ($32^\circ \pm 2^\circ\text{C}$).

5.3.1 If the specimen has been treated with a water-repellent finish, it shall be wet-out in a 0.5 percent soap solution at a temperature of $90^\circ \pm 4^\circ\text{F}$ ($32^\circ \pm 2^\circ\text{C}$) and then rinsed with distilled water.

5.4 The excess water shall then be removed by squeezing or extraction. The specimen shall be placed in a stainless steel container with approximately 50 times its dry weight of the sodium hypochlorite solution at a temperature of $90^\circ \pm 4^\circ\text{F}$ ($32^\circ \pm 2^\circ\text{C}$).

5.5 The container with the specimen and the sodium hypochlorite solution shall be placed in the Launder-Ometer or similar machine immediately and agitated for 1 hour at a temperature of $90^\circ \pm 4^\circ\text{F}$ ($32^\circ \pm 2^\circ\text{C}$). The period of agitation shall be measured from the time of placing the specimen in the container to the time of its removal.

5.6 The specimen shall be removed from the container and rinsed thoroughly in running water at a temperature of $100 \pm 4^\circ\text{F}$ ($38^\circ \pm 2^\circ\text{C}$) for 5 minutes, with squeezing at intervals.

5.7 After rinsing, the excess water shall be removed by squeezing or any other convenient means, and the specimen placed in a container together with a solution of sodium bisulfite (antichlor) equal to approximately 50 times the dry weight of the specimen for 10 minutes at a temperature of $90^\circ \pm 4^\circ\text{F}$ ($32^\circ \pm 2^\circ\text{C}$) with occasional stirring.

METHOD 5600

5.8 At the end of the antichlor treatment the specimen shall be rinsed thoroughly in running water at $90^{\circ} \pm 4^{\circ}\text{F}$ ($32^{\circ} \pm 2^{\circ}\text{C}$) for a period of 5 minutes with occasional squeezing. If at the end of this period the specimen does not appear to be free of bisulfite, it may be acidified with an acetic acid solution at a temperature of $81^{\circ} \pm 6^{\circ}\text{F}$ ($27^{\circ} \pm 3^{\circ}\text{C}$) with light agitation for 5 minutes. The specimen is then rinsed thoroughly for an additional 5 minute period.

5.9 After rinsing, the excess water shall be removed by extraction and the specimen air-dried at room temperature or oven-dried at a temperature of $221^{\circ} \pm 9^{\circ}\text{F}$ ($105^{\circ} \pm 5^{\circ}\text{C}$).

5.10 The specimen shall then be lightly sprayed with water and pressed between clean white cotton cloths using a flat-bed steam press or hand-iron at a temperature of 275° to 302°F (135° to 150°C).

5.11 Evaluation.

5.11.1 Evaluation shall be conducted in accordance with Method 9010.

5.11.2 The color change of the test specimen shall be evaluated to determine the colorfastness to chlorine bleaching.

5.11.3 Standard sample. The color change exhibited by the tested specimen when compared to the untested specimen retained shall be evaluated against the color change exhibited by the tested standard when compared to the untested standard retained.

5.11.3.1 Specimen.

Pass: Color change equal to or less than that of the standard sample.

Fail: Color change greater than that of the standard sample.

5.11.4 No standard sample. When a standard sample has not been established, evaluation of the test specimen for change in color shall be rated as follows:

5.11.4.1 Test specimen when compared to the specimen retained untested for comparison.

Excellent: No perceptible color change.

Good: Perceptible but not an appreciable change in color.

Fair: Appreciable but not an objectionable change in color.

Poor: Objectionable change in color.

"Appreciable change in color" means a change that is immediately noticeable in comparing the test specimen with the original sample for comparison. If closer inspection or a change of angle of light is required to make apparent a slight change of color, the change is not considered appreciable.

6. REPORT

6.1 Standard sample. Colorfastness to chlorine bleaching shall be reported as "pass" or "fail" when compared with the standard sample. If the test specimen shows failure when compared to comparable material of the standard sample, the specimen shall be reported as failing. When failure is reported, the severest departure (i.e., actual rating "fair" or "poor") of the change of the test specimen shall be distinguished and reported.

6.2 No standard sample. Colorfastness to chlorine bleaching shall be reported as "pass" or "fail" when the test specimen is evaluated and rated in accordance with the adjective ratings of 5.11.4. Failure of the test specimen to meet the adjective rating specified in the applicable procurement document shall be reported as failure. When failure is reported, the severest departure (i.e., actual rating "fair" or "poor") of the change of the test specimen shall be distinguished and reported.

7. NOTES

7.1 A machine and accessories of the type described may be purchased from Atlas Electric Devices Co., 4114 No. Ravenswood Avenue, Chicago, IL 60613.

7.2 Cotton cloth may be obtained from Testfabrics, Inc., P.O. Box 53, 200 Blackford Ave., Middlesex, NJ 08846.

METHOD 5605
July 20, 1978

COLORFASTNESS TO COMBINED LAUNDERING AND BLEACHING
OF TEXTILE MATERIALS; LAUNDER-OMETER METHOD

1. SCOPE

1.1 This method is intended for determining the colorfastness of textile materials to combined laundering and bleaching.

2. TEST SPECIMEN

2.1 Standard sample. Unless otherwise specified in the procurement document, when a standard sample has been established, the required specimens from the sample unit of the material to be tested and one specimen from the standard sample, shall be as follows:

2.1.1 Cloth. Two to six grams of cloth.

2.1.2 Yarn, thread, light cordage, tape, webbing and braid. Two to six grams of the applicable material, so held together to form a unit for testing.

2.2 No standard sample. Unless otherwise specified in the procurement document, when a standard sample has not been established, the required specimens from the same unit of the material to be tested shall be as specified in 2.1.1 or 2.1.2. One additional specimen shall be taken from each sample unit of the material to be tested and shall be retained, untested, for comparison. All specimens shall be taken from adjacent areas of the sample unit.

3. NUMBER OF DETERMINATIONS

3.1 Unless otherwise specified in the procurement document, one specimen shall be tested from each sample unit.

4. APPARATUS, REAGENTS AND METHOD CITED

4.1 Apparatus.

4.1.1 Launder-Ometer. Launder-Ometer or similar machine having a metal adapter in which tightly capped stainless steel cylindrical containers 8 inches (203 mm) in length by 3-1/2 inches (89 mm) in diameter are held with

METHOD 5605

their bases toward a horizontal shaft 2 inches (51 mm) from the center of rotation. The shaft shall rotate at a speed of 40 to 45 rpm. Each container shall be equipped with a sealing device having solvent resistant rings. An equal number of stainless steel containers shall be fastened on opposite sides of the rotating shaft in order to maintain balanced and smooth rotation during the test. The Launder-Ometer or similar machine shall be maintained at a temperature of $158^{\circ} \pm 4^{\circ}\text{F}$ ($70^{\circ} \pm 2^{\circ}\text{C}$) (see 7.1).

4.1.2 Pressing equipment.

4.1.2.1 Steam press. Flat-bed press maintained at a temperature of 275° to 302°F (135° to 150°C).

4.1.2.2 Hand-iron. A hand-iron weighing approximately 6 pounds (2.7 kg) and maintained at a temperature of 275° to 302°F (135° to 150°C).

4.1.3 Extractor. A centrifugal extractor of the laundry type with a perforated basket approximately 11 inches (280 mm) deep by 17 inches (432 mm) in diameter with an operating speed of approximately 1500 rpm.

4.1.4 Oven. Circulating-air oven capable of maintaining the required temperature within $\pm 4^{\circ}\text{F}$ ($\pm 2^{\circ}\text{C}$).

4.1.5 Color transfer cloth (see 7.2).

4.1.5.1 Unless otherwise specified in the procurement document, the color transfer cloth shall be desized, bleached, starch-free 96 x 100 combed cotton lawn cloth, 4 ounces per square yard (136 g/m^2).

4.1.5.2 When specified in the procurement document, the color transfer cloth may be replaced by one of the following multifiber test cloths:

4.1.5.2.1 Color transfer cloth. A test cloth with a 6-fiber repeat made up of equal bars of acetate, cotton, nylon 66, polyester (polyethylene terephthalate) acrylic and wool. Each 6-fiber repeat shall measure approximately 2 inches (51 mm) and shall be separated by a waste filling stripe (see 7.2).

4.1.5.2.2 Three fiber cloth containing acetate, wool, and bleached cotton, so woven as to show 1 inch (25 mm) square each of acetate and wool and 2 inch (51 mm) square of cotton.

4.1.6 White thread.

4.1.7 Bleached, desized, cotton cloth.

4.2 Reagents.

4.2.1 Water. The water used in the preparation of the soap solution shall have a hardness of not more than 50 parts per million.

4.2.2 Sodium hypochlorite solution (bleach). Any commercial preparation of sodium hypochlorite (NaOCl-bleach solution) diluted with distilled water to an available chlorine content of 1.0 percent and adjusted to a hydrogen ion content (pH) of 11.0 ± 0.2 with a buffer solution specified in 4.2.3.

4.2.3 Buffer solution. The buffer solution needed to adjust the pH to the required level shall be as follows:

4.2.3.1 Five parts of 1 percent solution of sodium bicarbonate (NaHCO_3), and 95 parts of 5 percent solution of sodium carbonate (Na_2CO_3). Both solutions shall be prepared with distilled water.

4.2.3.2 Ten percent solution of sodium hydroxide (NaOH).

4.2.4 Soap solution. Soap solution containing 0.5 percent soap, P-S-1792, Soap, Laundry (Neutral and Built), Type I, classes 1 or 2; and 0.2 percent sodium metasilicate, O-S-604, Sodium Metasilicate, Technical, Type I.

4.2.5 Antichlor. Sodium bisulfite solution (antichlor) prepared by dissolving 5 grams of sodium bisulfite (NaHSO_3) anhydrous, C.P. in 1000 ml of distilled water.

4.2.6 Acetic acid solution. 0.14 g of glacial acetic acid, C.P. diluted to 1000 ml.

4.3 Method cited.

Method 9010, Shade Matching of Textile Materials; Visual Method.

5. PROCEDURE

5.1 Standard sample. When a standard sample has been established, one specimen from the standard sample shall be tested at the same time and under the same conditions as the specimen of the material being tested.

5.2 No standard sample. When a standard sample has not been established, one specimen from each sample unit to be tested shall be retained, untested, for comparison.

METHOD 5605

5.3 Unless otherwise specified in the procurement document, a 2-inch (51 mm) square of 6-fiber color transfer cloth shall be sewn with white thread to one corner of the test specimen or may be attached by some other suitable means. A 2-inch (51 mm) square of the color transfer cloth shall also be attached to one corner of the specimen from the standard sample when it is used for comparison. When the specimen has been printed, the color transfer cloth shall be attached to the printed side.

5.4 Laundering cycle and temperature. Unless otherwise specified in the procurement document, the laundering cycle of the Launder-Ometer or similar machine shall be 45 minutes and the temperature of the cylinders and contents maintained at $158^{\circ} \pm 4^{\circ}\text{F}$ ($70^{\circ} \pm 2^{\circ}\text{C}$).

5.5 The specimen assembly shall be placed in the stainless steel containers together with 45 ml. of the soap and sodium metasilicate solution, 5 ml of the sodium hypochlorite solution at a temperature of $158^{\circ} \pm 4^{\circ}\text{F}$ ($70^{\circ} \pm 2^{\circ}\text{C}$).

5.5.1 The containers are placed in the Launder-Ometer or similar machine and agitated for the period of time and at the required temperature.

5.6 At the end of the laundering cycle the specimen assembly shall be removed from the container and rinsed thoroughly in running water at a temperature of $104^{\circ} \pm 4^{\circ}\text{F}$ ($40^{\circ} \pm 2^{\circ}\text{C}$) for 5 minutes.

5.6.1 After rinsing, the excess water shall be removed by squeezing or any other convenient means and the specimen assembly placed in a container together with a solution of sodium bisulfite (antichlor) equal to approximately 50 times the dry weight of the specimen assembly at a temperature of $90^{\circ} \pm 4^{\circ}\text{F}$ ($32^{\circ} \pm 2^{\circ}\text{C}$) for 10 minutes with occasional stirring.

5.6.2 At the end of the antichlor treatment the specimen assembly shall be rinsed thoroughly in running water at a temperature of $81^{\circ} \pm 4^{\circ}\text{F}$ ($27^{\circ} \pm 2^{\circ}\text{C}$) for a period of 5 minutes with occasional squeezing. If at the end of this period the specimen does not appear to be free of bisulfite, it may be acidified with an acetic acid solution at a temperature of $81^{\circ} \pm 4^{\circ}\text{F}$ ($27^{\circ} \pm 2^{\circ}\text{C}$), with light agitation for 5 minutes. The specimen is then-rinsed thoroughly for an additional 5 minute period.

5.7 After rinsing, the excess water shall be removed by extraction and the specimen air-dried at room temperature or oven-dried at a temperature of $221^{\circ} \pm 9^{\circ}\text{F}$ ($105^{\circ} \pm 5^{\circ}\text{C}$).

5.7.1 The specimen assembly shall then be lightly sprayed with water and pressed between clean white cotton cloths using a flat-bed steam press or hand-iron at a temperature of 275° to 302°F (135° to 150°C) with the color transfer cloth uppermost and in full contact with the specimen.

5.8 Evaluation.

5.8.1 Evaluation shall be conducted in accordance with Method 9010.

5.8.2 The color change of the test specimen and the staining of the color transfer cloth shall be evaluated separately to determine the color-fastness to combined laundering and bleaching.

5.8.3 After testing evaluate only that stain evident on the stripe of the multi-fiber test cloth that is the same fiber or similar chemical nature as that of the dyed fabric (i.e., wool stripe for dyed wool; acetate stripe for dyed acetate; cotton stripe for either dyed cotton or viscose, and nylon stripe for both nylon and polyester). When dyed fabric or systems of unknown fiber combinations are involved, evaluate the total staining on all bars of the transfer cloth. The degree of stain shall be recorded for each individual stripe.

5.8.4 Standard sample. The color change exhibited by the tested specimen when compared to the untested specimen retained shall be evaluated against the color change exhibited by the tested standard when compared to the untested standard retained. Unless otherwise specified, the staining of the color transfer cloth of the specimen shall be evaluated against the staining of the color transfer cloth of the standard.

5.8.4.1 Specimen.

Pass: Color change equal to or less than that of the standard sample.
Fail: Color change greater than that of the standard sample.

5.8.4.2 Color transfer cloth.

Pass: Staining equal to or less than that attached to the standard sample.
Fail: Staining greater than that attached to the standard sample.

5.8.5 No standard sample. When a standard sample has not been established, evaluation of the test specimen for change in color and staining by its attached color transfer cloth shall be rated as follows:

5.8.5.1 Test specimen when compared to the specimen retained untested for comparison and color transfer cloth evaluated accordingly to the degree of staining shall be rated as:

Excellent: No perceptible color change and staining.
Good: Perceptible but not an appreciable change in color and staining.
Fair: Appreciable but not an objectionable change in color and staining.
Poor: Objectionable change in color and staining.

METHOD 5605

"Appreciable change in color" means a change that is immediately noticeable in comparing the test specimen with the original sample for comparison. If closer inspection or a change of angle of light is required to make apparent a slight change of color, the change is not considered appreciable.

6. REPORT

6.1 Standard sample. Colorfastness to combined laundering and bleaching shall be reported as "pass" or "fail" when compared with the standard sample. If either the test specimen or the transfer cloth of the test specimen shows failure when compared to comparable material of the standard sample, the specimen shall be reported as failing. When failure is reported, the severest departure (i.e., the actual rating "fair" or "poor") of the change of the test specimen or staining of specific fibers of the color transfer cloth shall be distinguished and reported.

6.2 No standard sample. Colorfastness to combined laundering and bleaching shall be reported as "pass" or "fail" when the test specimen and color transfer cloth are evaluated and rated in accordance with the adjective ratings of 5.8.5. Failure of either the test specimen or the color transfer cloth to meet the adjective rating specified in the applicable procurement document, shall be reported as failure. When failure is reported, the severest departure (i.e., the actual rating "fair" or "poor") of the change of test specimen or staining of specific fibers of the color transfer cloth, shall be distinguished and reported.

7. NOTES

7.1 A machine and accessories of the type described in this method may be purchased from Atlas Electric Devices Co., 4114 No. Ravenswood Ave., Chicago, IL 60613.

7.2 Multifiber test cloth (color transfer cloth) and cotton cloth may be obtained from Testfabrics, Inc., P.O. Box 53, 200 Blackford Ave., Middlesex, NJ 08846.

METHOD 5610
July 20, 1978

COLORFASTNESS TO LAUNDERING OF COTTON AND
LINEN TEXTILE MATERIALS; LAUNDER-OMETER METHOD

1. SCOPE

1.1 This method is intended for determining the colorfastness of cotton and linen or blends of cotton and linen with other fibers to laundering.

2. TEST SPECIMEN

2.1 Standard sample. Unless otherwise specified in the procurement document, when a standard sample has been established, the required specimen from the sample unit of the material to be tested, and one specimen from the standard sample, shall be as follows:

2.1.1 Cloth. Two to six grams of cloth.

2.1.2 Yarn, thread, light cordage, tape, webbing and braid. Two to six grams of the applicable material, so held together to form a unit for testing.

2.2 No standard sample. Unless otherwise specified in the procurement document, when a standard sample has not been established, the required specimens from the sample unit of the material to be tested shall be as specified in 2.1.1 or 2.1.2, except that the specimen shall weigh four grams. One additional specimen shall be taken from each sample unit of the material to be tested and shall be retained, untested, for comparison. All specimens shall be taken from adjacent areas of the sample unit.

3. NUMBER OF DETERMINATIONS

3.1 Unless otherwise specified in the procurement document, one specimen shall be tested from each sample unit.

4. APPARATUS, REAGENTS AND METHOD CITED

4.1 Apparatus.

4.1.1 Laundry-Ometer. A Laundry-Ometer or similar machine having a metal adapter in which tightly capped stainless steel cylindrical containers 5 inches (127 mm) in length by 3 inches (76 mm) in diameter are held with their bases toward a horizontal shaft 2 inches (51 mm) from the center of rotation. The shaft shall rotate at 40 to 45 rpm. Each container shall be equipped with a sealing device having solvent resistant rings. An equal number of stainless

FED. TEST METHOD STD. NO. 191A

METHOD 5610

steel containers shall be fastened on opposite sides of the rotating shaft in order to maintain balanced and smooth rotation during the test. The Launder-Ometer or similar machine shall be maintained at a temperature of $158^{\circ} \pm 4^{\circ}\text{F}$ ($70^{\circ} \pm 2^{\circ}\text{C}$) (see 7.1).

4.1.2 Ten stainless steel balls, 1/4 inch (6 mm) in diameter per container (see 7.1).

4.1.3 Pressing equipment.

4.1.3.1 Steam press. Flat-bed press maintained at a temperature of 275° to 302°F (135° to 150°C).

4.1.3.2 Hand-iron. A hand-iron weighing approximately 6 pounds (2.7 kg) and maintained at a temperature of 275° to 302°F (135° to 150°C).

4.1.4 Extractor. A centrifugal extractor of the laundry type with a perforated basket approximately 11 inches (280 mm) deep by 17 inches (432 mm) in diameter, with an operating speed of approximately 1500 rpm.

4.1.5 Oven. Circulating-air oven capable of maintaining the required temperature within $\pm 4^{\circ}\text{F}$ ($\pm 2^{\circ}\text{C}$).

4.1.6 Color transfer cloth. A test cloth with a 6-fiber repeat made up of equal bars of acetate, cotton, nylon 66, polyester (polyethylene terephthalate) acrylic and wool. Each 6-fiber repeat shall measure approximately 2 inches (51 mm) and shall be separated by a waste filling stripe (see 7.2).

4.1.7 White thread.

4.1.8 Bleached, desized, cotton cloth (see 7.2).

4.2 Reagents.

4.2.1 Soap solution. Soap and soda solution containing 0.5 percent soap, P-S-1792, Soap, Laundry (Neutral and Built), type I, classes 1 or 2, and 0.2 percent sodium carbonate anhydrous in water of a hardness not over 50 parts per million.

4.2.2 Acetic acid. A 0.05 percent solution of acetic acid, C.P., 28 percent.

4.3 Method cited.

Method 9010, Shade Matching of Textile Materials; Visual Method.

5. PROCEDURE

5.1 Standard sample. When a standard sample has been established one specimen of the standard sample shall be laundered at the same time and under the same conditions as the specimen of the material being tested.

5.2 No standard sample. When a standard sample has not been established, one specimen from each sample unit to be tested shall be retained, untested, for comparison.

5.3 Unless otherwise specified in the procurement document, a 2-inch (51 mm) square of the 6-fiber color transfer cloth shall be sewn with white thread to one corner of the test specimen or may be attached by some other suitable means. A 2-inch (51 mm) square of the color transfer cloth shall also be attached to one corner of the specimen from the standard sample when it is used for comparison.

5.4 Laundering cycle and temperature. Unless otherwise specified in the procurement document, the laundering cycle of the Launder-Ometer or similar machine shall be 30 minutes and the temperature of the container and its contents shall be maintained at $158^{\circ} \pm 4^{\circ}\text{F}$ ($70^{\circ} \pm 2^{\circ}\text{C}$).

5.5 The specimen assembly shall be placed in the stainless steel containers together with 100 ml of the soap and soda solution at $158^{\circ} \pm 4^{\circ}\text{F}$ ($70^{\circ} \pm 2^{\circ}\text{C}$) and ten stainless steel balls.

5.6 The containers are placed in the Launder-Ometer or similar machine and agitated for the required time and at the required temperature.

5.7 At the end of the laundering cycle the specimen assembly shall be removed from the container and rinsed thoroughly in running water at a temperature of $104^{\circ} \pm 4^{\circ}\text{F}$ ($40^{\circ} \pm 2^{\circ}\text{C}$) for 5 minutes.

5.7.1 After rinsing the specimen assembly the excess water shall be removed by squeezing or extraction. The specimen assembly shall then be placed in a container of 0.05 percent solution of acetic acid and agitated for 5 minutes at a temperature of $77^{\circ} \pm 4^{\circ}\text{F}$ ($25^{\circ} \pm 2^{\circ}\text{C}$).

5.7.2 At the end of the acetic acid rinse the specimen assembly shall be thoroughly rinsed with running water at a temperature of $77^{\circ} \pm 4^{\circ}\text{F}$ ($25^{\circ} \pm 2^{\circ}\text{C}$) for 5 minutes.

5.8 When rinsing of the specimen assembly is completed the excess water shall be removed by extraction and then the specimen assembly air-dried at room temperature or dried in a circulating air oven at $221^{\circ} \pm 4^{\circ}\text{F}$ ($105^{\circ} \pm 2^{\circ}\text{C}$).

METHOD 5610

5.9 The specimen assembly shall then be lightly sprayed with water and pressed between clean white cotton cloths using a flat-bed steam press or hand-iron at a temperature of 275° to 302°F (135° to 150°C) with the color transfer cloth uppermost and in full contact with the specimen.

5.10 Evaluation.

5.10.1 Evaluation shall be conducted in accordance with Method 9010.

5.10.2 The color change of the test specimen and the staining of the color transfer cloth shall be evaluated separately to determine the color-fastness to laundering.

5.10.3 After testing evaluate only that stain evident on the stripe of the multi-fiber test cloth that is the same fiber or similar chemical nature as that of the dyed fabric (i.e., wool stripe for dyed wool; acetate stripe for dyed acetate; cotton stripe for either dyed cotton or viscose, and nylon stripe for both nylon and polyester). When dyed fabric or systems of unknown fiber combinations are involved, evaluate the total staining on all bars of the transfer cloth. The degree of stain shall be recorded for each individual stripe.

5.10.4 Standard sample. The color change exhibited by the tested specimen when compared to the untested specimen retained shall be evaluated against the color change exhibited by the tested standard when compared to the untested standard retained. Unless otherwise specified, the staining of the color transfer cloth of the specimen shall be evaluated against the staining of the color transfer cloth of the standard.

5.10.4.1 Specimen.

Pass: Color change equal to or less than that of the standard sample.
Fail: Color change greater than that of the standard sample.

5.10.4.2 Color transfer cloth.

Pass: Staining equal to or less than that attached to the standard sample.
Fail: Staining greater than that attached to the standard sample.

5.10.5 No standard sample. When a standard sample has not been established, evaluation of the test specimen for change in color and staining by its attached color transfer cloth shall be rated as follows:

5.10.5.1 Test specimen when compared to the specimen retained untested for comparison and color transfer cloth evaluated according to the degree of staining shall be rated as:

METHOD 5610

Excellent: No perceptible color change and staining.
Good: Perceptible but not an appreciable change in color and staining.
Fair: Appreciable but not an objectionable change in color and staining.
Poor: Objectionable change in color and staining.

"Appreciable change in color" means a change that is immediately noticeable in comparing the test specimen with the original sample for comparison. If closer inspection or a change of angle of light is required to make apparent a slight change of color, the change is not considered appreciable.

6. REPORT

6.1 Standard sample. Colorfastness to laundering shall be reported as "pass" or "fail" when compared with the standard sample. If either the test specimen or the transfer cloth of the test specimen shows failure when compared to comparable material of the standard sample the specimen shall be reported as failing. When failure is reported, the severest departure (i.e., the actual rating "fair" or "poor") of the change of the test specimen or staining of specific fibers of the color transfer cloth, shall be distinguished and reported.

6.2 No standard sample. Colorfastness to laundering shall be reported as "pass" or "fail" when the test specimen and color transfer cloth are evaluated and rated in accordance with the adjective ratings of 5.10.5. Failure of either the test specimen or the color transfer cloth to meet the adjective rating specified in the applicable procurement document shall be reported as failure. When failure is reported, the severest departure (i.e., the actual rating "fair" or "poor") of the change of the test specimen or staining of specific fibers of the color transfer cloth, shall be distinguished and reported.

7. NOTES

7.1 A machine and accessories of the type described may be purchased from Atlas Electric Devices CO., 4114 No. Ravenswood Avenue, Chicago, IL 60613.

7.2 Multifiber test cloth (color transfer cloth) and cotton cloth may be obtained from Testfabrics, Inc., P.O. Box 53, 200 Blackford Ave., Middlesex, NJ 08846.

METHOD 5612
July 20, 1978

COLORFASTNESS TO LAUNDERING OF COTTON AND LINEN

CLOTH; WASH WHEEL METHOD

1. SCOPE

1.1 This method is intended for determining the colorfastness of cotton and linen fabrics (woven and knitted) when subjected to a normal laundering procedure.

2. TEST SPECIMEN

2.1 Standard sample. Unless otherwise specified in the procurement document, when a standard sample has been established, the required specimens from the sample unit of the material to be tested and one specimen from the standard sample, shall be as follows:

2.1.1 Cloth. The specimen shall be a square of cloth not less than 20 inches by 20 inches (508 mm by 508 mm).

2.2 No standard sample. Unless otherwise specified in the procurement document, when a standard sample has not been established, the required specimens from the sample unit of the material to be tested shall be as specified in 2.1.1. One additional specimen shall be taken from each sample unit of the material to be tested, and shall be retained, untested, for comparison. All specimens shall be taken from adjacent areas of the sample unit.

3. NUMBER OF DETERMINATIONS

3.1 Unless otherwise specified in the procurement document, one specimen shall be tested from each sample unit.

4. APPARATUS, REAGENT AND METHOD CITED

4.1 Apparatus.

4.1.1 Wash wheel (see 7.1). The wash wheel shall be cylindrical and of the reversing type. The wheel (cage) shall be 20 to 24 inches (508 mm to 610 mm) inside diameter and 20 to 24 inches (508 mm to 610 mm) inside length. There shall be three fins each approximately 3 inches (76 mm) wide extending the full length of the inside of the wheel. One fin shall be located every 120° around the inside diameter of the wheel. The wash wheel shall rotate at a speed of 30 revolutions per minute making 5 to 10 revolutions before reversing. The water

FED. TEST METHOD STD. NO. 191A

METHOD 5612

inlets shall be large enough to permit filling the wheel to an 8-inch (203 mm) level in less than 2 minutes, and the outlet shall be large enough to permit discharge of this same amount of water in less than 2 minutes. The machine shall be equipped with a pipe for injecting live steam that shall be capable of raising the temperature of water at an 8-inch (203 mm) level from 100° to 140°F (38° to 60°C) in less than 2 minutes.

4.1.1.1 The water wheel shall be equipped with a thermometer or other equivalent equipment for determining the temperature of the water during the washing and rinsing procedures and with an outside water gage that will indicate the level of the water in the wheel.

4.1.2 Pressing equipment. A flat-bed press measuring 24 inches by 50 inches (610 mm by 1270 mm) or larger. Any flat-bed press capable of pressing a specimen 22 inches (559 mm) square or a hand-iron weighing approximately 6 pounds (2.7 kg) may be used as an alternative. The flat press or iron shall be equipped with a temperature control to maintain the temperature between 275° and 300°F (135° and 149°C).

4.1.3 Measuring scale. Yardstick, meterstick or metal tape graduated in 1/8 inch (1 mm) increments.

4.1.4 Drying equipment.

4.1.4.1 Rack and drying trays. A rack and tray of any convenient size over 22 by 22 inches (559 mm by 559 mm). The bottoms of the trays shall be a wire mesh, and the size of the-mesh shall be a minimum of 1/2 by 1/2 inch (13 mm by 13 mm). When the trays are in the rack, they shall be separated by a distance of not less than 1-1/2 inches (38 mm) and openings shall be provided in the rack for circulation of the air.

4.1.4.2 Extractor. A centrifugal extractor of the laundry-type with a perforated basket, approximately 11 inches (280 mm) deep by 17 inches (432 mm) in diameter, with an operating speed of approximately 1500 revolutions per minute.

4.1.4.3 Drying oven. A circulating air oven thermostatically controlled and capable of maintaining the temperature at 221° to 230°F (105° to 110°C).

4.1.5 Color transfer cloth. A test cloth with a 6-fiber repeat made up of equal bars of acetate, cotton, nylon 66, polyester (polyethylene terephthalate) acrylic and wool. Each 6-fiber repeat shall measure approximately 2 inches (51 mm) and shall be separated by a waste filling stripe (see 7.2).

4.1.6 White thread.

FED. TEST METHOD STD. NO. 191A

4.1.7 Bleached, desized, cotton cloth (see 7.2).

4.2 Reagent.

4.2.1 Detergent. Soap solution conforming to P-S-1792, Soap, Laundry (Neutral and Built), type I, classes 1 or 2. A stock solution of the soap may be prepared by dissolving 1 pound (454 g) of chip soap in 1 gallon (3.8 liters) of hot water. When cooled, this forms a thick homogeneous jelly which may be used as required.

4.3 Method cited.

Method 9010, Shade Matching of Textile Materials; Visual Method.

5. PROCEDURE

5.1 Standard sample. When a standard sample has been established, one specimen of the standard sample shall be laundered at the same time and under the same conditions as the specimen of the material being tested.

5.2 No standard sample. When a standard sample has not been established, one specimen from each sample unit to be tested shall be retained, untested, for comparison.

5.3 Unless otherwise specified in the purchase document, a 2-inch (51 mm) square of 6-fiber color transfer cloth shall be sewn with white thread to one corner of the test specimen or may be attached by some other suitable means. A 2-inch (51 mm) square of the color transfer cloth shall also be attached to one corner of the specimen from the standard sample when it is used for comparison.

5.4 Preparation of specimen.

5.4.1 Woven and warp knitted (single layer) cloth. Three specimens shall be selected from the cloth (sample unit) as follows: one specimen from each side of the cloth to within 3 inches (76 mm) of the selvage and one specimen from the center of the cloth. No two specimens shall contain the same filling yarns or courses. The specimen shall be laid without tension on a flat surface, care being taken that the cloth is free from wrinkles or creases. Three distances, each a minimum of 18 inches (457 mm) shall be measured and marked off parallel to each of the warp and filling or wale and course directions of the specimen. The distances shall be a minimum of 6 inches (152 mm) apart and at least 1 inch (25 mm) from any edge of the specimen. The distance may be marked with indelible ink and a fine panted pen, or by sewing fine threads into the cloth, or by stamping. The measured distance shall be parallel to the respective yarns.

METHOD 5612

5.4.2 Circular and tubular knit cloths. Three distances, each a minimum of 18 inches (457 mm) shall be measured and marked off parallel to the wale directions of the specimen. The distances shall be a minimum of 6 inches (152 mm) apart. Three width measurements shall be made and marked off parallel to the course direction of the specimen. The distances shall be a minimum of 6 inches (152 mm) apart.

5.4.3 Cloth 18 inches (457 mm) and less in width. Three distances, each a minimum of 18 inches (457 mm), shall be measured and marked off parallel to the warp or wale direction. Three width measurements shall be made and marked off along the full width of the cloth parallel to the filling or course direction. The distances shall be a minimum of 6 inches (152 mm) apart.

5.5 Washing. The specimen shall be placed in the wash wheel with sufficient other similar cloth to make up a dry load of $3 \pm 1/4$ pounds (1361 \pm 113 g). Start the wash wheel to rotate, and note the time. Immediately add water at a temperature of $(100^\circ \pm 9^\circ\text{F})$ ($38^\circ \pm 5^\circ\text{C}$) of not over 50 parts per million hardness to the wheel to a level of $7 \pm 1/2$ inches (178 \pm 13 mm); this level will be increased by condensed steam. Inject steam into the wheel until the temperature is between 203° and 212°F (95° and 100°C), and then shut off all steam. The steam shall be added as soon as the opening of the steam pipe into the wheel is completely covered with water. Then add sufficient soap-to furnish a good running suds.

5.5.1 The soap solution shall be drained off 37 minutes after the wash wheel begins to rotate, substantially emptying the wheel of soap and water at the end of 40 minutes from the time the wash wheel was started.

5.5.2 The wash wheel shall be immediately refilled to a level of $8-1/2 \pm 1/2$ Inch (216 \pm 13 mm) with water at a temperature of $100 \pm 9^\circ\text{F}$ ($38^\circ \pm 5^\circ\text{C}$). Inject steam until the temperature is 60 to 65°C (140 to 149°F). The water shall be drained off at such a time so that the wheel has become substantially empty of water at the end of 45 minutes from the time the wash wheel was started.

5.5.3 For a third time, the wash wheel shall be immediately refilled to a level of $8-1/2 \pm 1/2$ inch (216 \pm 13 mm) with water at a temperature of $100^\circ \pm 9^\circ\text{F}$ ($38^\circ \pm 5^\circ\text{C}$). Inject steam until the temperature is 140° to 149°F (67 to 65°C). The water shall be drained off at such a time so that the wheel has become substantially empty of water at the end of 55 minutes from the time the wash wheel was started. The wash wheel shall then be run without further addition of water and shall be stopped at 60 minutes from the time the wheel was started.

5.6 Extraction. The specimen shall be removed from the wash wheel and the excess water removed by extraction for a period of 5 minutes.

5.7 Drying.

5.7.1 Knit cloths. After extraction, the specimen of knit cloth shall be spread out on the drying tray to remove wrinkles, but not distorted, and permitted to dry overnight at room temperature. A current of air from an electric fan may be directed onto the specimen, or the specimen on the drying tray may be placed in the drying oven at a temperature of 221° to 230°F (105° to 110°C) to facilitate drying.

5.7.2 Woven cloths. After extraction, the specimen shall be dried as described in 5.4.1. The dry specimen shall be allowed to cool for 5 minutes, sprinkled with water to permit damp pressing, and allowed to stand in this condition for 5 minutes.

5.7.2.1 When specified by the procurement document, the cloth shall be pressed without drying.

5.8 Pressing.

5.8.1 Knit cloths. Unless otherwise specified in the procurement document, the knit cloth shall not be pressed before measuring the shrinkage. When pressing of the knit cloth is specified, the specimen shall be pressed as described in 5.8.2.

5.8.2 Woven cloth. The extracted specimen, 5.6, or the dried and dampened specimen, 5.4.2, shall be smoothed to remove wrinkles, but not distorted and shall then be pressed either with a flat-bed press or hand-iron. The head of the press or the hand-iron shall be at a temperature of 275° to 300°F (135° to 149°C) during the pressing operation. When a hand-iron is used, the iron shall not be slid back and forth on the specimen, but simply pressed down upon it in a manner simulating the action of the flat-bed press.

5.9 Evaluation.

5.9.1 Evaluation shall be conducted in accordance with Method 9010.

5.9.2 The color change of the test specimen and the staining of the color transfer cloth shall be evaluated separately to determine the color-fastness to laundering.

5.9.3 After testing evaluate only that stain evident on the stripe of the multi-fiber test cloth that is the same fiber or similar chemical nature as that of the dyed fabric (i.e., wool stripe for dyed wool; acetate stripe for dyed acetate; cotton stripe for either dyed cotton or viscose, and nylon stripe for both nylon and polyester). When dyed fabric or systems of unknown fiber combinations are involved, evaluate the total staining on all bars of the transfer cloth. The degree of stain shall be recorded for each individual stripe.

METHOD 5612

5.9.4 Standard sample. The color change exhibited by the tested specimen when compared to the untested specimen retained shall be evaluated against the color change exhibited by the tested standard when compared to the untested standard retained. Unless otherwise specified, the staining of the color transfer cloth of the specimen shall be evaluated against the staining of the color transfer cloth of the standard.

5.9.4.1 Specimen.

Pass: Color change equal to or less than that of the standard sample.

Fail: Color change greater than that of the standard sample.

5.9.4.2 Color transfer cloth.

Pass: Staining equal to or less than that attached to the standard sample.

Fail: Staining greater than that attached to the standard sample.

5.9.5 No standard sample. When a standard sample has not been established, evaluation of the test specimen for change in color and staining by its attached color transfer cloth shall be rated as follows:

5.9.5.1 Test specimen when compared to the specimen retained, untested, for comparison and color transfer cloth evaluated according to the degree of staining shall be rated as:

Excellent: No perceptible color change and staining.

Good: Perceptible but not an appreciable change in color and staining.

Fair: Appreciable but not an objectionable change in color and staining.

Poor: Objectionable change in color and staining.

"Appreciable change in color" means a change that is immediately noticeable in comparing the test specimen with the original sample for comparison. If closer inspection or a change of angle of light is required to make apparent a slight change of color, the change is not considered appreciable.

6. REPORT

6.1 Standard sample. Colorfastness to laundering shall be reported as "pass" or "fail" when compared with the standard sample. If either the test specimen or the transfer cloth of the test specimen shows failure when compared to comparable material of the standard sample, the specimen shall be reported as failing. When failure is reported, the severest departure (i.e., the actual rating "fair" or "poor") of the change of the test specimen or staining of specific fibers of the color transfer cloth, shall be distinguished and reported.

METHOD 5612

6.2 No standard sample. Colorfastness to laundering shall be reported as "pass" or "fail" when the test specimen and color transfer cloth are evaluated and rated in accordance with the adjective ratings of 5.9.5. Failure of either the test specimen or the color transfer cloth, to meet the adjective rating specified in the applicable procurement document, shall be reported as failure. When failure is reported, the severest departure (i.e., the actual rating "fair" or "poor") of the change of the test specimen or staining of specific fibers of the color transfer cloth, shall be distinguished and reported.

7. NOTES

7.1 A machine and accessories of the type described may be purchased from:

Ewing Division of Powercom
P.O. Box 454
Troy, NY 12181

7.2 Multifiber test cloth (color transfer cloth) and cotton cloth may be obtained from Testfabrics, Inc., P.O. Box 53, 200 Blackford Ave., Middlesex, NJ 08846.

COLORFASTNESS TO LAUNDERING OF WOOL, SILK, RAYON AND

OTHER TEXTILE MATERIALS; LAUNDER-OMETER METHOD

1. SCOPE

1.1 This method is intended for determining the colorfastness to laundering of wool, silk, rayon, and other textile materials.

2. TEST SPECIMEN

2.1 Standard sample. Unless otherwise specified in the procurement document, when a standard sample has been established, the required specimens from the sample unit of the material to be tested and one specimen from the standard sample shall be as follows:

2.1.1 Cloth. Two to six grams of cloth.

2.1.2 Yarn, thread, light cordage, tape, webbing and braid. Two to six grams of the applicable material, so held together to form a unit for testing.

2.2 No standard sample. Unless otherwise specified in the procurement document, when a standard sample has not been established, the required specimens from the sample unit of the material to be tested shall be as specified in 2.1.1 or 2.1.2. One additional specimen shall be taken from each sample unit of the material to be tested, and shall be retained, untested, for comparison. All specimens shall be taken from adjacent areas of the sample unit.

3. NUMBER OF DETERMINATIONS

3.1 Unless otherwise specified in the procurement document, one specimen shall be tested from each sample unit.

4. APPARATUS, REAGENTS AND METHOD CITED

4.1 Apparatus.

4.1.1 Launder-Ometer. Launder-Ometer or similar machine having a metal adapter in which tightly capped stainless steel cylindrical containers 5 inches (127 mm) in length by 3 inches (76 mm) in diameter are held with their bases toward a horizontal shaft 2 inches (51 mm) from the center of

METHOD 5614

rotation. The shaft shall rotate at a speed of 40 to 45 rpm. Each container shall be equipped with a sealing device having solvent resistant rings. An equal number of stainless steel containers shall be fastened on opposite sides of the rotating shaft in order to maintain balanced and smooth rotation during the test. The Launder-Ometer or similar machine shall be maintained at a temperature of $100^{\circ} \pm 4^{\circ}\text{F}$ ($38^{\circ} \pm 2^{\circ}\text{C}$) (see 7.1).

4.1.2 Ten stainless steel balls, 1/4 inch (6 mm) in diameter, per container.

4.1.3 Pressing equipment.

4.1.3.1 Steam press. Flat-bed press maintained at a temperature of 275° to 302°F (135° to 150°C).

4.1.3.2 Hand-iron. A hand-iron weighing approximately 6 pounds (2.7 kg) and maintained at a temperature of 275° to 302°F (135° to 150°C).

4.1.4 Extractor. A centrifugal extractor of the laundry type with a perforated basket approximately 11 inches (280 mm) deep by 17 inches (432 mm) in diameter, with an operating speed of approximately 1500 rpm.

4.1.5 Color transfer cloth. A test cloth with a 6-fiber repeat made up of equal bars of acetate, cottons nylon 66, polyester (polyethylene terephthalate) acrylic and wool. Each 6-fiber repeat shall measure approximately 2 inches (51 mm) and shall be separated by a waste filling stripe (see 7.2).

4.1.6 When specified in the material specification, the color transfer cloth may be replaced by a cloth of undyed wool, silk, rayon or other type of fiber.

4.1.7 White thread.

4.1.8 Bleached, desized, cotton cloth (see 7.2).

4.2 Reagents.

4.2.1 Soap solution. Soap solution containing 0.5 percent soap, P-S-1792 Soap, Laundry (Neutral and Built), type I, classes 1 or 2, and 0.2 percent sodium carbonate anhydrous in water of hardness of not over 50 parts per million.

4.3 Method cited.

Method 9010, Shade Matching of Textile Materials; Visual Method.

5. PROCEDURE

5.1 Standard sample. When a standard sample has been established, one specimen of the standard sample shall be laundered at the same time and under the same conditions as the specimen of the material being tested.

5.2 No standard sample. When a standard sample has not been established, one specimen from each sample unit to be tested shall be retained, untested, for comparison.

5.3 Unless otherwise specified in the procurement document, a 2-inch (51 mm) square of 6-fiber color transfer cloth shall be sewn with white thread to one corner of the test specimen or may be attached by some other suitable means. A 2-inch (51 mm) square of the color transfer cloth shall also be attached to one corner of the specimen from the standard sample when it is used for comparison.

5.4 Laundering cycle and temperature. Unless otherwise specified in the procurement document, the laundering cycle of the Launder-Ometer or similar machine shall be 30 minutes and the temperature of the container and its contents shall be maintained at $100^{\circ} \pm 4^{\circ}\text{F}$ ($38^{\circ} \pm 2^{\circ}\text{C}$).

5.5 The specimen assembly shall be placed in a stainless steel container containing 100 ml of soap solution and ten stainless steel balls.

5.6 The container is placed in the Launder-Ometer or similar machine and agitated for the required time and at the required temperature.

5.7 At the end of the laundering cycle the specimen assembly shall be removed from the container and rinsed thoroughly in running water at a temperature of $100^{\circ} \pm 4^{\circ}\text{F}$ ($38^{\circ} \pm 2^{\circ}\text{C}$) for 5 minutes. The rinsing shall be repeated three times with squeezing out of the excess water between each rinsing.

5.8 When rinsing of the specimen assembly is completed the assembly shall be wrapped in a clean white cloth and the excess water removed by squeezing or extraction, and air-dried.

5.9 The specimen assembly shall then be lightly sprayed with water and pressed between clean white cotton cloths using a flat-bed steam press or hand-iron at a temperature of 275° to 302°F (135° to 150°C) with the color transfer cloth uppermost and in full contact with the specimen.

METHOD 5614

5.10 Evaluation.

5.10.1 Evaluation shall be conducted in accordance with Method 9010.

5.10.2 The color change of the test specimen and the staining of the color transfer cloth shall be evaluated separately to determine the color-fastness to laundering.

5.10.3 After testing evaluate only that stain evident on the stripe of the multi-fiber test cloth that is the same fiber or similar chemical nature as that of the dyed fabric (i.e., wool stripe for dyed wool; acetate stripe for dyed acetate; cotton stripe for either dyed cotton or viscose, and nylon stripe for both nylon and polyester). When dyed fabric or systems of unknown fiber combinations are involved, evaluate the total staining on all bars of the transfer cloth. The degree of stain shall be recorded for each individual stripe.

5.10.4 Standard sample. The color change exhibited by the tested specimen when compared to the untested specimen retained shall be evaluated against the color change exhibited by the tested standard when compared to the untested standard retained. Unless otherwise specified, the staining of the color transfer cloth of the specimen shall be evaluated against the staining of the color transfer cloth of the standard.

5.10.4.1 Specimen.

Pass: Color change equal to or less than that of the standard sample.

Fail: Color change greater than that of the standard sample.

5.10.4.2 Color transfer cloth.

Pass: Staining equal to or less than that attached to the standard sample.

Fail: Staining greater than that attached to the standard sample.

5.10.5 No standard sample. When a standard sample has not been established, evaluation of the test specimen for change in color and staining by its attached color transfer cloth shall be rated as follows:

5.10.5.1 Test specimen when compared to the specimen retained untested for comparison and color transfer cloth evaluated according to the degree of staining shall be rated as:

Excellent: No perceptible color change and staining.

Good: Perceptible but not an appreciable change in color and staining.

Fair: Appreciable but not an objectionable change in color and staining.

Poor: Objectionable change in color and staining.

METHOD 5614

"Appreciable change in color" means a change that is immediately noticeable in comparing the test specimen with the original sample for comparison. If closer inspection or a change of angle of light is required to make apparent a slight change of color, the change is not considered appreciable.

6. REPORT

6.1 Standard sample. Colorfastness to laundering shall be reported as "pass" or "fail" when compared with the standard sample. If either the test specimen or the transfer cloth of the test specimen shows failure when compared to comparable material of the standard sample, the specimen shall be reported as failing. When failure is reported, the severest departure (i.e., the actual rating "fair" or "poor") of the change of the test specimen or staining of specific fibers of the color transfer cloth, shall be distinguished and reported.

6.2 No standard sample. Colorfastness to laundering shall be reported as "pass" or "fail" when the test specimen and color transfer cloth are evaluated and rated in accordance with the adjective ratings of 5.10.5. Failure of either the test specimen or the color transfer cloth to meet the adjective rating specified in the applicable procurement document shall be reported as failing. When failure is reported, the severest departure (i.e., the actual rating "fair" or "poor") of the change of test specimen or staining of specific fibers of the color transfer cloth, shall be distinguished and reported.

7. NOTES

7.1 A machine and accessories of the type described may be purchased from Atlas Electric Devices Company, 4114 No. Ravenswood Avenue, Chicago, IL 60613.

7.2 Multifiber test cloth (color transfer cloth) and cotton cloth may be obtained from Testfabrics, Inc., P.O. Box 53, 200 Blackford Ave., Middlesex, NJ 08846.

METHOD 5616
July 20, 1978

COLORFASTNESS TO LAUNDERING OF WOOL, SILK AND RAYON

CLOTH: WASH WHEEL METHOD

1. SCOPE

1.1 This method is intended for determining the colorfastness of wool, silk, and rayon fabrics when subjected to a normal laundering procedure.

2. TEST SPECIMEN

2.1 Standard sample. Unless otherwise specified in the procurement document, when a standard sample has been established, the required specimens from the sample unit of the material to be tested and one specimen from the standard sample shall be as follows:

2.1.1 Cloth. The specimen shall be a square of cloth not less than 20 inches by 20 inches (508 mm by 508 mm).

2.2 No standard sample. Unless otherwise specified in the procurement document, when a standard sample has not been established, the required specimens from the sample unit of the material to be tested shall be as specified in 2.1.1. One additional specimen shall be taken from each sample unit of the material to be tested, and shall be retained, untested, for comparison. All specimens shall be taken from adjacent areas of the sample unit.

3. NUMBER OF DETERMINATIONS

3.1 Unless otherwise specified in the procurement document, one specimen shall be tested from each sample unit.

4. APPARATUS, REAGENT AND METHOD CITED

4.1 Apparatus.

4.1.1 Wash wheel (see 7.1). The wash wheel shall be cylindrical and of the reversing type. The wheel (cage) shall be 20 to 24 inches (508 mm to 610 mm) inside diameter and 20 to 24 inches (508 mm to 610 mm) inside length. There shall be three fins each approximately 3 inches (76 mm) wide extending the full length of the inside of the wheel. One fin shall be located every 120° around the inside diameter of the wheel. The wash wheel shall rotate at a speed of 30 revolutions per minute making 5 to 10 revolutions before reversing. The water inlets shall be large enough to permit filling the wheel to an 8-inch

FED. TEST METHOD STD. NO. 191A

METHOD 5616

(203 mm) level in less than 2 minutes, and the outlet shall be large enough to permit discharge of this same amount of water in less than 2 minutes. The machine shall be equipped with a pipe for injecting live steam that shall be capable of raising the temperature of water at an 8-inch (203 mm) level from 100° to 140°F (38° to 60°C) in less than 2 minutes.

4.1.1.1 The water wheel shall be equipped with a thermometer or other equivalent equipment for determining the temperature of the water during the washing and rinsing procedures and with an outside water gage that will indicate the level of the water in the wheel.

4.1.2 Pressing equipment. A flat-bed press measuring 24 inches by 50 inches (610 mm by 1270 mm) or larger. Any flat-bed press capable of pressing a specimen 22 inches (559 mm) square or a hand-iron weighing approximately 6 pounds (2.7 kg) may be used as an alternative. The flat press or iron shall be equipped with a temperature control to maintain the temperature between 275° and 300°F (135° and 149°C).

4.1.3 Measuring scale. Yardstick, meterstick or metal tape graduated in 1/8 inch (1 mm) increment.

4.1.4 Drying equipment.

4.1.4.1 Rack and drying trays. A rack and tray of any convenient size over 22 by 22 inches (559 mm by 559 mm). The bottoms of the trays shall be a wire mesh, and the size of the mesh shall be a minimum of 1/2 by 1/2 inch (13 mm by 13 mm). When the trays are in the rack, they shall be separated by a distance of not less than 1-1/2 inches (38 mm) and openings shall be provided in the rack for circulation of the air.

4.1.4.2 Extractor. A centrifugal extractor of the laundry-type with a perforated basket, approximately 11 inches (280 mm) deep by 17 inches (432 mm) in diameter, with an operating speed of approximately 1500 revolutions per minute.

4.1.4.3 Drying oven. A circulating air oven thermostatically controlled and capable of maintaining the temperature of 221° to 230°F (105° to 110°C).

4.1.5 Color transfer cloth. A test cloth with a 6-fiber repeat made up of equal bars of acetate, cotton, nylon 66, polyester (polyethylene terephthalate) acrylic and wool. Each 6-fiber repeat shall measure approximately 2 inches (51 mm) and shall be separated by a waste filling stripe (see 7.2).

4.1.6 White thread.

4.1.7 Bleached, desized, cotton cloth (see 7.2).

4.2 Reagent.

4.2.1 Detergent. Soap solution conforming to P-S-1792, Soap, Laundry (Neutral and Built), type I, classes 1 or 2. A stock solution of the soap may be prepared by dissolving 1 pound (454 g) of chip soap in 1 gallon (3.8 liters) of hot water. When cooled, this forms a thick homogenous jelly which may be used as required.

4.3 Method cited.

Method 9010, Shade Matching of Textile Materials; Visual Method

5. PROCEDURE

5.1 Standard sample. When a standard sample has been established, one specimen of the standard sample shall be laundered at the same time and under the same conditions as the specimen of the material being tested.

5.2 No standard sample. When a standard sample has not been established, one specimen from each sample unit to be tested shall be retained, untested, for comparison.

5.3 Unless otherwise specified in the procurement document, a 2-inch (51 mm) square of 6-fiber color transfer cloth shall be sewn with white thread to one corner of the test specimen or may be attached by some other suitable means. A 2-inch (51 mm) square of the color transfer cloth shall also be attached to one corner of the specimen from the standard sample when it is used for comparison.

5.4 Preparation of specimen.

5.4.1 Woven and warp knitted (single layer) cloth. Three specimens shall be selected from the cloth (sample unit) as follows: one specimen from each side of the cloth to within 3 inches (76 mm) of the selvage and one specimen from the center of the cloth. No two specimens shall contain the same filling yarns or courses. The specimen shall be laid without tension on a flat surface, care being taken that the cloth is free from wrinkles or creases. Three distances, each a minimum of 18 inches (457 mm), shall be measured and marked off parallel to each of the warp and filling or wale and course directions of the specimen. The distances shall be a minimum of 6 inches (152 mm) apart and at least 1 inch (25 mm) from any edge of the specimen. The distance may be marked with indelible ink and a fine pointed pen, or by sewing fine threads into the cloth, or by stamping, The measured distance shall be parallel to the respective yarns.

METHOD 5616

5.4.2 Circular and tubular knit cloths. Three distances, each a minimum of 18 inches (457 mm) shall be measured and marked off parallel to the wale directions of the specimen. The distances shall be a minimum of 6 inches (152 mm) apart. Three width measurements shall be made and marked off parallel to the course direction of the specimen. The distances shall be a minimum of 6 inches (152 mm) apart.

5.4.3 Cloth 18 inches (457 mm) and less in width. Three distances, each a minimum of 18 inches (457 mm), shall be measured and marked off parallel to the warp or wale direction. Three width measurements shall be made and marked off along the full width of the cloth parallel to the filling or course direction. The distances shall be a minimum of 6 inches (152 mm) apart.

5.5 Washing. Water at a temperature of $100^{\circ} \pm 4^{\circ}\text{F}$ ($38 \pm 2^{\circ}\text{C}$) and not over 50 parts per million hardness shall be added to the wash wheel to a depth of $7 \pm 1/2$ inches (178 ± 13 mm) inside the wheel (cage). Sufficient soap shall be added to furnish a good running suds. The specimen shall be placed in the wash wheel with other similar cloth to make up a dry load of $3 \pm 1/4$ pounds (1.36 ± 0.11 kg).

5.5.1 The wheel shall then be started and run for 15 minutes. At the end of the 15 minute period, the machine shall be stopped and the soap solution drained off.

5.5.2 Water at a temperature of $100^{\circ} \pm 4^{\circ}\text{F}$ ($28^{\circ} \pm 2^{\circ}\text{C}$) shall be again added to the wash wheel to give a depth of $7 \pm 1/2$ inches (178 ± 13 mm) inside the wheel (cage). The wash wheel shall be started and run for a period of 5 minutes, again stopped, and the water drained off.

5.5.3 For a third time, the wash wheel shall be filled with water at a temperature of $100^{\circ} \pm 4^{\circ}\text{F}$ ($38^{\circ} \pm 2^{\circ}\text{C}$) to give a depth of $7 \pm 1/2$ inches (178 ± 13 mm) and run for an additional 10 minutes. At the end of the 10 minute period, the wash wheel shall be stopped and the water drained off.

5.6 Extraction. The specimen shall be removed from the wash wheel and the excess water removed by extraction for a period of 5 minutes.

5.7 Drying.

50701 Knit cloths. After extraction, specimens of knit cloth shall be spread out on the drying tray to remove wrinkles, but not distorted, and permitted to dry overnight at room temperature. A current of air from an electric fan may be directed onto the specimen, or the specimen on the dry-tray may be placed in the drying oven at a temperature of 221° to 230°F (105° to 110°C) to facilitate drying.

METHOD 5616

5.7.2 Woven cloths. After extraction, the specimen shall be dried as described in 5.4.1. The dry specimen shall be allowed to cool for 5 minutes, sprinkled with water to permit damp pressing, and allowed to stand in this condition for 5 minutes.

5.7.2.1 When specified by the procurement document, the cloth shall be pressed without drying.

5.8 Pressing.

5.8.1 Knit cloths. Unless otherwise specified in the procurement document, knit cloth shall not be pressed before measuring the shrinkage. When pressing of knit cloth is specified, the specimen shall be pressed as described in 5.8.2.

5.8.2 Woven cloth. The extracted specimen (5.6) or the dried and dampened specimen (5.4.2) shall be smoothed to remove wrinkles, but not distorted and then pressed either with a flat-bed press or hand-iron. The head of the press or the hand-iron shall be at a temperature of 275° to 300°F (135° to 149°C) during the pressing operation. When a hand-iron is used, the iron shall not be slid back and forth on the specimen, but simply pressed down upon it in a manner simulating the action of the flat-bed press.

5.9 Evaluation.

5.9.1 Evaluation shall be conducted in accordance with Method 9010.

5.9.2 The color change of the test specimen and the staining of the color transfer cloth shall be evaluated separately to determine the colorfastness to laundering.

5.9.3 After testing evaluate only that stain evident on the stripe of the multi-fiber test cloth that is the same fiber or similar chemical nature as that of the dyed fabric (i.e., wool stripe for dyed wool; acetate stripe for dyed acetate; cotton stripe for either dyed cotton or viscose, and nylon stripe for both nylon and polyester). When dyed fabric or systems of unknown fiber combinations are involved, evaluate the total staining on all bars of the transfer cloth. The degree of stain shall be recorded for each individual stripe.

5.9.4 Standard sample. The color change exhibited by the tested specimen when compared to the untested specimen retained shall be evaluated against color change exhibited by the tested standard when compared to the untested standard retained. The staining of the color transfer cloth of the specimen shall be evaluated against the staining of the color transfer cloth of the standard.

METHOD 5616

5.9.4.1 Specimen.

Pass: Color change equal to or less than that of the standard sample.
Fail: Color change greater than that of the standard sample.

5.9.4.2 Color transfer cloth.

Pass: Staining equal to or less than that attached to the standard sample.
Fail: Staining greater than that attached to the standard sample.

5.9.5 No standard sample. When a standard sample has not been established, evaluation of the test specimen for change in color and staining by its attached color transfer cloth shall be rated as follows:

5.9.5.1 Test specimen when compared to the specimen retained untested for comparison and color transfer cloth evaluated according to the degree of staining shall be rated as:

Excellent: No perceptible color change and staining.
Good: Perceptible but not an appreciable change in color and staining.
Fair: Appreciable but not an objectionable change in color and staining.
Poor: Objectionable change in color and staining.

"Appreciable change in color" means a change that is immediately noticeable in comparing the test specimen with the original sample for comparison. If closer inspection or a change of angle of light is required to make apparent a slight change of color, the change is not considered appreciable.

6. REPORT

6.1 Standard sample. Colorfastness to laundering shall be reported as "pass" or "fail" when compared with the standard sample. If either the test specimen or the transfer cloth of the test specimen shows failure when compared to comparable material of the standard sample the specimen shall be reported as failing. When failure is reported, the severest departure (i.e., the actual rating "fair" or "poor") of the change of the test specimen or staining of specific fibers of the color transfer cloth, shall be distinguished and reported.

6.2 No standard sample. Colorfastness to laundering shall be reported as "pass" or "fail" when the test specimen and color transfer cloth are evaluated and rated in accordance with the adjective ratings of 5.9.5. Failure of either the test specimen or the color transfer cloth to meet the

METHOD 5616

adjective rating specified in the applicable procurement document shall be reported as failure. When failure is reported, the severest departure (i.e., the actual rating "fair" or "poor") of the change of the test specimen or staining of specific fibers of the color transfer cloth, shall be distinguished and reported.

7. NOTES

7.1 A machine and accessories of the type described may be purchased from:

Ewing Division of Powercom
P.O. Box 454
Troy, NY 12181

7.2 Multifiber test cloth (color transfer cloth) and cotton cloth may be obtained from Testfabrics, Inc., P.O. Box 53, 200 Blackford Ave., Middlesex, NJ 08846.

COLORFASTNESS TO DRY CLEANING OF TEXTILE

MATERIALS ; PETROLEUM SOLVENT

1. SCOPE

1.1 This method is intended for determining the colorfastness of textile materials to dry cleaning with a petroleum solvent.

2. TEST SPECIMEN

2.1 Standard sample. Unless otherwise specified in the procurement document, when a standard sample has been established, the required specimen of the material to be tested and one specimen from the standard sample shall be as follows:

2.1.1 Cloth. A rectangle of cloth 2 inches by 4 inches (51 mm by 102 mm).

2.1.2 Yarn, thread, and light cordage. A sufficient amount of the applicable material, so held together to form a unit weighing not less than 1 gram nor more than 3 grams.

2.2 No standard sample. Unless otherwise specified in the procurement document, when a standard sample has not been established, the required specimens from the sample unit of the material to be tested shall be as specified in 2.1.1 or 2.1.2. One additional specimen shall be taken from each sample unit of the material to be tested and shall be retained, untested, for comparison. All specimens shall be taken from adjacent areas of the sample unit.

3. NUMBER OF DETERMINATIONS

3.1 Unless otherwise specified in the procurement document, one specimen shall be tested from each sample unit.

4. APPARATUS, REAGENTS AND METHOD CITED

4.1 Apparatus.

4.1.1 Launder-Ometer. Launder-Ometer or similar machine having a metal adapter in which tightly capped stainless steel cylindrical containers 5 inches (127 mm) in length by 3 inches (76 mm) in diameter are held with their bases toward a horizontal shaft 2 inches (51 mm) from the center of rotation. The shaft shall rotate at a speed of 40 to 45 rpm. Each container shall be equipped with a sealing device having solvent resistant rings. An equal number of stainless steel containers shall be fastened on opposite sides of the rotating shaft in order to maintain balanced and smooth rotation during the test. The Launder-Ometer or similar machine shall be maintained at a temperature of $81^{\circ} \pm 4^{\circ}\text{F}$ ($27^{\circ} \pm 2^{\circ}\text{C}$) (see 7.1).

METHOD 5620

4.1.2 Pressing equipment.

4.1.2.1 Steam press. Flat-bed press maintained at a temperature of 275° to 302°F (135° to 150°C).

4.1.2.2 Hand-iron. A hand-iron weighing approximately 6 pounds (2.7 kg) and maintained at a temperature of 275° to 302°F (135° to 150°C).

4.1.3 Extractor. A centrifugal extractor of the laundry type with a perforated basket approximately 11 inches (280 mm) deep by 17 inches (432 mm) in diameter, with an operating speed of approximately 1500 rpm.

4.1.4 Muslin covered frame or screen suitable for drying specimen at room temperature.

4.1.5 Cheesecloth.

4.2 Reagents.

4.2.1 Dry cleaning solvent shall conform to requirements of P-D-680, Dry Cleaning Solvent.

4.3 Method cited.

Method 9010, Shade Matching of Textile Materials; Visual Method.

5. PROCEDURE

5.1 Conditioning. All specimens shall be conditioned and tested under standard atmospheric conditions in accordance with section 4 of this standard.

5.2 Standard sample. When a standard sample has been established, one specimen of the standard sample shall be dry cleaned at the same time and under the same conditions as the specimen of the material being used.

5.3 No standard sample. When a standard sample has not been established, one specimen from each sample unit to be tested shall be retained, untested, for comparison.

5.4 The specimen shall be placed in a stainless steel container together with 150 ml of the dry cleaning solvent and agitated for 20 minutes in the Launder-Ometer or similar machine at a temperature of 81° to 84°F (27° to 29°C).

METHOD 5620

5.5 The specimen shall be removed from the container, extracted and then laid out on a horizontal surface such as a muslin covered frame or screen and allowed to dry at room temperature.

5.6 When dry, the specimen shall be pressed as follows:

5.6.1 Standard method. The specimen shall be laid out on the bed of a flat-bed steam press. The head of the press shall be lowered and held in contact with the specimen and steam shall be admitted from the back of the press for 5 to 10 seconds.

5.6.2 Alternate method. The specimen shall be laid on a padded ironing board. Cover with two layers of cheesecloth on which is placed a damp press cloth which has been saturated in water and wrung out so as to retain a moisture content equal to approximately 75 percent of the dry weight, followed by two more thicknesses of cheesecloth and pressed with a hand-iron.

5.6.3 The temperature of either pressing equipment shall be 275° to 302°F (135° to 150°C).

5.7 After pressing by either of the above methods, the specimen shall be allowed to cool on a smooth horizontal surface for 4 hours at room temperature before evaluating.

5.8 Evaluation.

5.8.1 Evaluation shall be conducted in accordance with Method 9010.

5.8.2 The color change of the test specimen shall be evaluated to determine the colorfastness to dry cleaning.

5.8.3 Standard sample. The color change exhibited by the tested specimen when compared to the untested specimen retained shall be evaluated against the color change exhibited by the tested standard when compared to the untested standard retained.

5.8.3.1 Specimen.

Pass: Color change equal to or less than that of the standard sample.

Fail: Color change greater than that of the standard sample.

5.8.4 No standard sample. When a standard sample has not been established, evaluation of the test specimen shall be rated as follows:

METHOD 5620

5.8.4.1 Test specimen when compared to the specimen retained untested for comparison.

Excellent: No perceptible color change.
Good: Perceptible but not an appreciable change in color.
Fair: Appreciable but not an objectionable change in color.
Poor: Objectionable change in color.

"Appreciable change in color" means a change that is immediately noticeable in comparing the test specimen with the original sample for comparison. If closer inspection or a change of angle of light is required to make apparent a slight change in color, the change is not considered appreciable.

60 REPORT

6.1 Standard sample. Colorfastness to dry cleaning shall be reported as "pass" or "fail" when compared with the standard sample. If the test specimen shows failure when compared to comparable material of the standard sample, the specimen shall be reported as failing. When failure is reported, the severest departure (i.e., the actual rating "fair" or "poor") of the change of the test specimen shall be distinguished and reported.

6.2 No standard sample. Colorfastness to dry cleaning shall be reported as "pass" or "fail" when the test specimen is evaluated and rated in accordance with the adjective ratings of 5.8.4. Failure of the test specimen to meet the adjective rating specified in the applicable procurement document, shall be reported as failing. When failure is reported, the severest departure (i.e., the actual rating "fair" or "poor") of the change of the test specimen shall be distinguished and reported.

7. NOTES

7.1 A machine and accessories of the type described may be purchased from Atlas Electric Devices Company, 4114 No. Ravenswood Avenue, Chicago, IL 60613.

METHOD 5621
July 20, 1978

COLORFASTNESS TO WET CLEANING OF TEXTILE MATERIALS;

PERCHLOROETHYLENE SOLVENT (ASSOCIATED WITH DRY CLEANING)

1. SCOPE

1.1 This method is intended for determining the colorfastness of textile materials to wet dry cleaning with perchloroethylene solvent.

2. TEST SPECIMEN

2.1 Standard sample. Unless otherwise specified in the procurement document, when a standard sample has been established, the required specimens from the sample unit of the material to be tested and one specimen from the standard sample shall be as follows:

2.1.1 Cloth. A rectangle of cloth 2 inches by 6 inches (51 mm by 152 mm). If one specimen of printed cloth does not include all of the colors in the design, additional specimens shall be taken so that all colors are included.

2.1.2 Yarn, thread, and light cordage. Sufficient amount of the applicable material so held together to form a unit weighing not less than 1 gram nor more than 3 grams.

2.2 No standard sample. Unless otherwise specified in the procurement document, when a standard sample has not been established the required specimens from the sample unit of the material to be tested shall be as specified in 2.1.1 or 2.1.2. One additional specimen shall be taken from each sample unit of the material to be tested, and shall be retained, untested, for comparison. All specimens shall be taken from adjacent areas of the sample unit.

3. NUMBER OF DETERMINATIONS

3.1 Unless otherwise specified in the procurement document, one specimen shall be tested from each sample unit.

4. APPARATUS, REAGENTS AND METHOD CITED

4.1 Apparatus.

4.1.1 Launder-Ometer. Launder-Ometer or similar machine having a metal adapter in which tightly capped stainless steel cylindrical containers 5 inches (127 mm) in length by 3 inches (76 mm) in diameter with their bases toward

FED. TEST METHOD STD. NO. 191A

METHOD 5621

a horizontal shaft 2 inches (51 mm) away from the center of rotation. The shaft shall rotate at a speed of 40 to 45 rpm. Each container shall be equipped with a sealing device having solvent resistant rings. An equal number of stainless steel containers shall be fastened on opposite sides of the rotating shaft in order to maintain balanced and smooth rotation during the test. The Launder-Ometer or similar machine shall be maintained at a temperature of $82^{\circ} \pm 4^{\circ}\text{F}$ ($28^{\circ} \pm 2^{\circ}\text{C}$) (see 7.1).

4.1.2 Ten stainless steel balls, 1/4 inch (6 mm) in diameter, per container.

4.1.3 Pressing equipment.

4.1.3.1 Steam press. Flat-bed press maintained at a temperature of 275° to 302°F (135° to 150°C).

4.1.3.2 Hand-iron. A hand-iron weighing approximately 6 pounds (2.7 kg) and maintained at a temperature of 275° to 302°F (135° to 150°C).

4.1.4 Extractor. A centrifugal extractor of the laundry type with a perforated basket approximately 11 inches (280 mm) deep by 17 inches (432 mm) in diameter with an operating speed of approximately 1500 rpm.

4.1.5 Muslin covered frame or screen suitable for drying specimen at room temperature.

4.1.6 Color transfer cloth. A test cloth with a 6-fiber repeat made up of equal bars of acetate, cotton, nylon 66, polyester (polyethylene terephthalate) acrylic and wool. Each 6-fiber repeat shall measure approximately 2 inches (51 mm) and shall be separated by a waste filling stripe (see 7.2).

4.1.7 White thread.

4.1.8 Cheesecloth.

4.2 Reagents.

4.2.1 Drycleaning solvent. Dry cleaning grade perchloroethylene (tetrachloroethylene) conforming to requirements of O-T-236, Tetrachloroethylene (Perchloroethylene) Technical Grade (see 7.3).

4.2.2 Dry cleaning soap. Dry cleaning soap is prepared by dissolving 35 g of potassium hydroxide in 89 ml of distilled water. The potassium hydroxide solution shall be poured slowly with constant stirring into a mixture of 250 ml of oleic acid, 724 ml of Stoddard solvent and 105 ml of cyclohexanol.

METHOD 5621

4.2.3 Cleaning solution. The cleaning solution is prepared by mixing together 995 parts by volume of dry cleaning grade perchloroethylene and five parts by volume of dry cleaning soap.

4.3 Method cited.

Method 9010, Shade Matching of Textile Materials; Visual Method.

5. PROCEDURE

5.1 All specimens shall be conditioned and tested under standard atmospheric conditions in accordance with section 4 of the standard.

5.2 Standard sample. When a standard sample has been established, one specimen of the standard sample shall be wet dry cleaned at the same time and under the same conditions as the specimen of the material being tested.

5.3 No standard sample. When a standard sample has not been established, one specimen from each sample unit to be tested shall be retained, untested, for comparison.

5.4 Unless otherwise specified, a 2-inch (51 mm) square of the 6-fiber color transfer cloth shall be sewn with white thread to one corner of the test specimen or may be attached by some other suitable means. A 2-inch (51 mm) square of the color transfer cloth shall also be attached to one corner of the specimen from the standard sample when it is used for comparison.

5.5 The conditioned specimen assembly shall be placed in a stainless steel container together with ten stainless steel balls and 50 ml of cleaning solution for each gram of total weight of the specimen assembly. The containers shall then be agitated for 25 minutes in the Launder-Ometer or similar machine at a temperature of $82^{\circ} \pm 4^{\circ}\text{F}$ ($28^{\circ} \pm 2^{\circ}\text{C}$).

5.5.1 The solution shall be poured out and replaced by an equal volume of fresh perchloroethylene without the added soap and the container returned to the machine and agitated for five minutes.

5.5.2 The procedure of 5.5.1 shall be repeated three more times. The total running time of the containers shall be 45 minutes.

5.6 The specimen assembly shall be removed from the container, extracted to remove excess solvent and then laid on a horizontal surface such as a muslin covered frame or a screen and allowed to air-dry at room temperature.

METHOD 5621

5.7 The specimen assembly from 5.6 shall be returned to the container together with an equal amount of distilled water equal to the volume of solvent used in 5.5.

5.7.1 The container shall then be agitated for 5 minutes in the Launder-Ometer or similar machine at a temperature of $82^{\circ} \pm 4^{\circ}\text{F}$ ($28^{\circ} \pm 2^{\circ}\text{C}$).

5.8 The water shall then be poured out and the procedures of 5.7 repeated.

5.9 The specimen assembly shall be removed from the container, extracted, and laid on a horizontal surface such as a muslin covered frame or screen and allowed to dry at room temperature.

5.10 When dry, the specimen assembly shall be pressed as follows:

5.10.1 Standard method. The specimen assembly shall be laid out on the bed of a flat-bed steam press with the color transfer cloth in full contact with the specimen. The head of the press shall be lowered and held in contact with the specimen assembly and steam shall be admitted from the back of the press for 5 to 10 seconds.

5.10.2 Alternate method. The specimen assembly shall be laid on a padded ironing board with the color transfer cloth in full contact with the specimen. Cover with two layers of cheesecloth on which is placed damp press cloth which has been saturated with water and wrung so as to retain a moisture content equal to approximately 75 percent of its dry weight, followed by two more thicknesses of cheesecloth and pressed with a hand-iron.

5.10.3 The temperature of either pressing equipment shall be 275° to 302°F (135° to 150°C).

5.11 After pressing by either one of the above methods, the specimen shall be allowed to cool on a smooth horizontal surface for 4 hours at room temperature before evaluating.

5.12 Evaluation.

5.12.1 Evaluation shall be conducted in accordance with Method 9010.

5.12.2 The color change of the test specimen and the staining of the color transfer cloth shall be evaluated separately to determine the color-fastness to wet dry cleaning.

METHOD 5621

5.12.3 After testing evaluate only that stain evident on the stripe of the multi-fiber test cloth that is the same fiber or similar chemical nature as that of the dyed fabric (i.e., wool stripe for dyed wool; acetate stripe for dyed acetate; cotton stripe for either dyed cotton or viscose, and nylon stripe for both nylon and polyester). When dyed fabric or systems of unknown fiber combinations are involved, evaluate the total staining on all bars of the transfer cloth. The degree of stain shall be recorded for each individual stripe.

5.12.4 Standard sample. The color change exhibited by the tested specimen when compared to the untested specimen retained, shall be evaluated against the color change exhibited by the tested standard when compared to the untested standard retained. Unless otherwise specified, the staining of the color transfer cloth of the specimen shall be evaluated against the staining of the color transfer cloth of the standard.

5.12.4.1 Specimen.

Pass: Color change equal or less than that of the standard sample.

Fail: Color change greater than that of the standard sample.

5.12.4.2 Color transfer cloth.

Pass: Staining equal to or less than that attached to the standard sample.

Fail: Staining greater than that attached to the standard sample.

5.12.5 No standard sample. When a standard sample has not been established, evaluation of the test specimen for change in color and staining by its attached color transfer cloth, shall be rated as follows:

5.12.5.1 Test specimen when compared to the specimen retained untested for comparison and color transfer cloth evaluated according to the degree of staining shall be rated as:

Excellent: No perceptible color change and staining.

Good: Perceptible but not an appreciable change in color and staining.

Fair: Appreciable but not an objectionable change in color and staining.

Poor: Objectionable change in color and staining.

"Appreciable change in color" means a change that is immediately noticeable in comparing the test specimen with the original sample for comparison. If closer inspection or a change of angle of light is required to make apparent a slight change of color, the change is not considered appreciable.

METHOD 5621

6. REPORT

6.1 Standard sample. Colorfastness to wet dry cleaning shall be reported as "pass" or "fail" when compared with the standard sample. If either the test specimen or the transfer cloth of the test specimen shows failure when compared to comparable material of the standard sample, the specimen shall be reported as failing. When a failure is reported, the severest departure (i.e., the actual rating "fair" or "poor") of the change of the test specimen or staining of specific fibers of the color transfer cloth, shall be distinguished and reported.

6.2 No standard sample. Colorfastness to wet dry cleaning shall be reported as "pass" or "fail" when the test specimen and color transfer cloth are evaluated and rated in accordance with the adjective ratings of 5.12.5. Failure of either the test specimen or the color transfer cloth to meet the adjective rating specified in the applicable procurement document shall be reported as failure. When failure is reported, the severest departure (i.e., the actual rating "fair" or "poor") of the change of test specimen or staining of specific fibers of the color transfer cloth, shall be distinguished and reported.

7. NOTES

7.1 A machine and accessories of the type described may be purchased from Atlas Electric Devices Co., 4114 No. Ravenswood Ave., Chicago, IL 60613.

7.2 A multifiber test cloth (color transfer cloth) may be obtained from Testfabrics, Inc., P.O. Box 53, 200 Blackford Ave., Middlesex, N.J 08846.

7.3 Perchloroethylene is toxic by inhalation, by prolonged or repeated contact with the skin or mucous membrane, or when ingested by mouth. The liquid can cause injuries to the eyes. However, with proper precautions it can be handled safely.

METHOD 5622
July 20, 1978COLORFASTNESS TO WET DRY CLEANING OF TEXTILE
MATERIALS; PETROLEUM SOLVENT

1. SCOPE

1.1 This method is intended for determining the colorfastness of textile materials to wet dry cleaning with petroleum solvent.

2. TEST SPECIMEN

2.1 Standard sample. Unless otherwise specified in the procurement document, when a standard sample has been established, the required specimens from the sample unit of the material to be tested and one specimen from the standard sample shall be as follows:

2.1.1 Cloth. A rectangle of cloth 2 inches by 6 inches (51 mm by 152 mm).

2.1.2 Yarn, thread, light cordage, tape, webbing and braid. Sufficient amount of material so held together to form a unit weighing not less than 1 g nor more than 3 g.

2.2 No standard sample. Unless otherwise specified in the procurement document, when a standard sample has not been established the required specimens from the sample unit of the material to be tested shall be as specified in 2.1.1 or 2.1.2. One additional specimen shall be taken from each sample unit of the material to be tested, and shall be retained, untested, for comparison. All specimens shall be taken from adjacent areas of the sample unit.

3. NUMBER OF DETERMINATIONS

3.1 Unless otherwise specified in the procurement document, one specimen shall be tested from each sample unit.

4. APPARATUS, REAGENTS AND METHOD CITED

4.1 Apparatus.

4.1.1 Launder-Ometer. A Launder-Ometer or similar machine having a metal adapter in which tightly capped stainless steel cylindrical containers 5 inches (127 mm) in length by 3 inches (76 mm) in diameter with their bases toward a horizontal shaft 2 inches (51 mm) away from the center of rotation. The shaft shall rotate at a speed of 40 to 45 rpm. Each container shall be equipped with a sealing device having solvent resistant rings. An equal number of stainless steel containers shall be fastened on opposite sides of the rotation shaft in order to maintain balanced and smooth rotation during the test. The Launder-Ometer or similar machine shall be maintained at a temperature of $81^{\circ} \pm 4^{\circ}\text{F}$ ($27^{\circ} \pm 2^{\circ}\text{C}$) (see 7.1).

METHOD 5622

4.1.2 Pressing equipment.

4.1.2.1 Steam press. Flat-bed press maintained at a temperature of 275° to 302°F (135° to 150°C).

4.1.2.2 Hand iron. A hand iron weighing approximately 6 pounds (2.7 kg) and maintained at a temperature of 275° to 302°F (135° to 150°C).

4.1.3 Extractor. A centrifugal extractor of the laundry type with a perforated basket approximately 11 inches (280 mm) deep by 17 inches (432 mm) in diameter with an operating speed of approximately 1500 rpm.

4.1.4 Muslin covered frame or screen suitable for drying specimen at room temperature.

4.1.5 Cheesecloth.

4.2 Reagents.

4.2.1 Dry cleaning solvent. The dry cleaning solvent shall conform to the requirements of type I of P-D-680, Dry Cleaning Solvent.

4.2.2 Dry cleaning soap. Dry cleaning soap is prepared by dissolving 35 g of potassium hydroxide in 89 ml of distilled water. The potassium hydroxide solution shall be pouted slowly with constant stirring into a mixture of 250 ml of oleic acid, 724 ml of dry cleaning solvent and 105 ml of cyclohexanol.

4.2.3 Cleaning solution. The cleaning solution is prepared by mixing together 950 parts by volume of dry cleaning solvent and 50 parts of dry cleaning soap.

4.3 Method cited.

Method 9010, Shade Matching of Textile Materials; Visual Method.

5. PROCEDURE

5.1 All specimens shall be conditioned and tested under Standard Atmospheric Conditions in accordance with Section 4 of this Standard.

5.2 Standard sample. When a standard sample has been established, one specimen of the standard sample shall be wet dry cleaned at the same time and under the same conditions as the specimen of the material being tested.

5.3 No standard sample. When a standard sample has not been established, one specimen from each sample unit to be tested shall be retained, untested, for comparison.

METHOD 5622

5.4 The conditioned specimen shall be placed in a stainless steel container together with an amount of cleaning solution equal to fifty times the total conditioned weight of the specimen and agitated for 20 minutes in the Launder-Ometer or similar machine at a temperature of $81 \pm 4^\circ$ ($27^\circ \pm 2^\circ\text{C}$).

5.4.1 The solution shall be poured out and replaced by an equal volume of fresh dry cleaning solvent without soap and alcohol added and agitated again for 20 minutes in the Launder-Ometer or similar machine at $81^\circ \pm 4^\circ\text{F}$ ($27^\circ \pm 2^\circ\text{C}$).

5.4.2 The solution shall be poured out and replaced by fresh dry cleaning solvent and agitated for another period of 20 minutes at $81^\circ \pm 4^\circ\text{F}$ ($27^\circ \pm 2^\circ\text{C}$).

5.5 The specimen shall be removed from the container, extracted to remove excess solvent, then laid on a horizontal surface such as a muslin covered frame or a screen and allowed to air dry at room temperature.

5.6 When dry, the specimen shall be pressed as follows:

5.6.1 Standard method. The specimen shall be laid out on the bed of a flat-bed steam press. The head of the press shall be lowered and held in contact with the specimen and steam shall be admitted from the back of the press for 5 to 10 seconds.

5.6.2 Alternate method. The specimen shall be laid on a padded ironing board. Cover with two layers of cheesecloth on which is placed a damp press cloth which has been saturated with water and wrung out so as to retain a moisture content equal to approximately 75 percent of its dry weight, followed by two more thicknesses of cheesecloth and pressed with a hand iron.

5.6.3 The temperature of either pressing equipment shall be 275° to 302°F (135° to 150°C).

5.7 After pressing by either one of the above methods, the specimen shall be allowed to cool on a smooth horizontal surface for 4 hours at room temperature before evaluating.

5.8 Evaluation.

5.8.1 Evaluation shall be conducted in accordance with Method 9010.

5.8.2 The color change of the test specimen shall be evaluated to determine the colorfastness to wet dry cleaning.

5.8.3 Standard sample. The color change exhibited by the tested specimen when compared to the untested specimen retained shall be evaluated against the color change exhibited by the tested standard when compared to the untested standard retained.

METHOD 5622

5.8.3.1 Specimen.

Pass: Color change equal to or less than that of the standard sample.
Fail: Color change greater than that of the standard sample.

5.8.4 No standard sample. When a standard sample has not been established, evaluation of the test specimen shall be rated as follows:

5.8.4.1 Test specimen when compared to the specimen retained untested for comparison shall be rated as:

Excellent: No perceptible color change.
Good: Perceptible but not an appreciable change in color.
Fair: Appreciable but not an objectionable change in color.
Poor: Objectionable change in color.

"Appreciable change in color" means a change that is immediately noticeable in comparing the test specimen with the original sample for comparison. If closer inspection or a change in angle of light is required to make apparent a slight change in color, the change is not considered appreciable.

6. REPORT

6.1 Standard sample. Colorfastness to wet dry cleaning shall be reported as "pass" or "fail" compared with the standard sample. If the test specimen shows failure when compared to comparable material of the standard sample, the specimen shall be reported as failing. When failure is reported, the severest departure (i.e. the actual rating, "fair" or "poor"), of the change of the test specimen shall be distinguished and reported.

6.2 No standard sample. Colorfastness to wet dry cleaning shall be reported as "pass" or "fail" when the test specimen is evaluated and rated in accordance with the adjective ratings of 5.8.4. Failure of the test specimen to meet the adjective rating specified in the applicable procurement document shall be reported as failure. When failure is reported, the severest departure (i.e. the actual rating "fair" or "poor"), of the change of the test specimen shall be distinguished and reported.

7. NOTES

7.1 A machine and accessories of the type described may be purchased from Atlas Electric Devices Company, 4114 N. Ravenswood Avenue, Chicago, IL 60613.

COLORFASTNESS OF TEXTILE MATERIALS TO WATER

1. SCOPE

1.1 This method is intended for determining the colorfastness of textile materials to cold water. It is applicable to dyed, printed or otherwise colored textiles of all kinds.

2. TEST SPECIMEN

2.1 Standard sample. Unless otherwise specified in the procurement document, when a standard sample has been established, the required specimens from each sample unit of the material to be tested and one specimen from the standard sample shall be as follows:

2.1.1 Cloth. A square of cloth 2-1/2 inches by 2-1/2 inches (64 mm by 64 mm).

2.1.2 Fibers, yarn, thread, light cordage, tape, webbing and braid. Sufficient amount of the applicable material that can be arranged to form a square 2-1/2 inches by 2-1/2 inches (64 mm by 64 mm). When evaluating narrow width material such as ribbon, tape, or webbing sufficient material shall be used so that the complete area of the transfer cloth will be in full contact with the test specimen.

2.2 No standard sample. Unless otherwise specified in the procurement document, when a standard sample has not been established, the required specimens from each sample unit of the material to be tested shall be as specified in 2.1.1 or 2.1.2. One additional specimen shall be taken from each sample unit of the material to be tested, and shall be retained, untested, for comparison. All specimens shall be taken from adjacent areas of the sample unit.

3. NUMBER OF DETERMINATIONS

3.1 Unless otherwise specified in the procurement document, one specimen shall be tested from each sample unit.

4. APPARATUS, REAGENTS AND METHOD CITED

4.1 Apparatus.4.1.1 Perspirometer or equivalent apparatus.

4.1.1.1 The perspirometer is a testing device capable of maintaining uniform pressure on the test specimen located between two glass plates or acrylic plates, 3 inches by 2-1/2 inches by 1/4 inch (76 mm by 64 mm by 6 mm) (see 7.1).

METHOD 5630

4.1.1.2 Either of the following two perspirometer models is permissible.

4.1.1.2.1 The pressure is obtained in one model by adding weights, with the plates being stacked vertically until the pressure is adjusted. When the required pressure is reached, the pressure plate is locked, the weights removed and the unit placed in the oven so that the plates and specimens are vertical.

4.1.1.2.2 The pressure in the second model is obtained by means of adjusting screw, the movable plate being made to exert increasing pressure against the test specimens until the required force is reached as indicated on the scale. The specimen unit is locked at this point, the assembly removed from the section applying the pressure and placed in the oven so that the plates and specimens are vertical.

4.1.2 Wringer. A wringer of the household type equipped with smooth rubber rolls 2-1/8 inches to 2-1/2 inches (54 mm to 64 mm) in diameter and not less than 11 inches (280 mm) nor more than 16 inches (406 mm) in length. The rubber rolls shall have a Shore durometer hardness of 70 to 80 (A Scale). The load exerted on the specimen shall be applied uniformly by means of attaching the weight, and the weight itself shall be such that the specimen wet weight shall be approximately 2-1/2 times its dry weight.

4.1.3 Oven. A circulating-air oven capable of maintaining the required temperature within $\pm 4^{\circ}\text{F}$ ($\pm 2^{\circ}\text{C}$).

4.1.4 Hand-iron. A hand-iron weighing approximately 6 pounds (2.7 kg) and maintained at a temperature of 275° to 302°F (135° to 150°C).

4.1.5 Color transfer cloth. A test cloth with a 6-fiber repeat made up of equal bars of acetate, cotton, nylon 66, polyester (polyethylene terephthalate) acrylic, and wool. Each 6-fiber repeat shall measure approximately 2 inches (51 mm) and shall be separated by a waste filling stripe (see 7.2).

4.1.6 White thread.

4.1.7 Bleached, desized, cotton cloth. (see 7.2)

4.2 Reagents.

4.2.1 Distilled water. Distilled water shall be boiled for 30 minutes and cooled to room temperature before testing.

4.3 Method cited.

Method 9010, Shade Matching of Textile Materials; Visual Method.

METHOD 5630

5. PROCEDURE

5.1 Standard sample. When a standard sample has been established, one specimen of the standard sample shall be tested at the same time and under the same conditions as the specimen of the material being tested.

5.2 No standard sample. When a standard sample has not been established, one specimen from each sample unit to be tested shall be retained, untested, for comparison.

5.3 Unless otherwise specified in the procurement document a 2-inch (51 mm) square of the 6-fiber color transfer cloth shall be sewn with white thread to one corner of the test specimen or may be attached by some other suitable means. A 2-inch (51 mm) square of the color transfer cloth shall also be attached to one corner of the specimen from the standard sample when it is used for comparison.

5.4 One specimen assembly (see 5.3) shall be immersed in the distilled water at $82^{\circ} \pm 9^{\circ}\text{F}$ ($28^{\circ} \pm 5^{\circ}\text{C}$) and allowed to soak 30 minutes with occasional stirring. Care shall be taken to insure that the assembly is thoroughly wetted.

5.5 The test assembly shall be removed from the distilled water and passed flat through the wringer to remove excess water so that the wet weight of the assembly shall be approximately 2-1/2 times its dry weight.

5.6 The test assembly shall then be placed between glass plates or acrylic plates, the color transfer cloth in full contact with the specimen and inserted in the perspirometer. The perspirometer shall be adjusted to produce a pressure of 10 pounds (44.5 N) on the specimen assembly.

5.7 The loaded test plate assembly shall be placed in the oven for a minimum of 2 hours and the temperature of the oven maintained at $100^{\circ} \pm 4^{\circ}\text{F}$ ($38^{\circ} \pm 2^{\circ}\text{C}$).

5.8 The specimen assemblies shall be removed from the test plates at the end of the 2 hour period. The specimen and transfer cloth shall be separated and dried out of contact with each other by pressing between clean white cotton cloths with a hand-iron at a temperature of 275° to 302°F (135° to 150°C).

5.9 Evaluation.

5.9.1 Evaluation shall be conducted in accordance with Method 9010.

5.9.2 The color change of the test specimen and the staining of the color transfer cloth shall be evaluated separately to determine the colorfastness to water.

5.9.3 After testing evaluate only that stain evident on the stripe of the multi-fiber test cloth that is the same fiber or similar chemical nature as that of the dyed fabric (i.e., wool stripe for dyed wool; acetate stripe for dyed acetate; cotton stripe for either dyed cotton or viscose, and nylon stripe for both nylon and polyester). When dyed fabric or systems of unknown fiber combinations are involved, evaluate the total staining on all bars of the transfer cloth. The degree of stain shall be recorded for each individual stripe.

METHOD 5630

5.9.4 Standard sample. The color change exhibited by the tested specimen when compared to the untested specimen retained shall be evaluated against the color change exhibited by the tested standard when compared to the untested standard retained. Unless otherwise specified, the staining of the color transfer cloth of the specimen shall be evaluated against the staining of the color transfer cloth of the standard.

5.9.4.1 Specimen.

Pass: Color change equal to or less than that of the standard sample.
Fail: Color change greater than that of the standard sample.

5.9.4.2 Color transfer cloth.

Pass: Staining equal to or less than that attached to the standard sample.
Fail: Staining greater than that attached to the standard sample.

5.9.5 No standard sample. When a standard sample has not been established, evaluation of the test specimen for change in color and staining by its attached color transfer cloth shall be rated as follows:

5.9.5.1 Test specimen when compared to the specimen retained, untested, for comparison and color transfer cloth evaluated according to the degree of staining shall be rated as:

Excellent: No perceptible color change and staining.
Good: Perceptible but not an appreciable change in color and staining.
Fair: Appreciable but not an objectionable change in color and staining.
Poor: Objectionable change in color and staining.

"Appreciable change in color" means a change that is immediately noticeable in comparing the test specimen with the original sample for comparison. If closer inspection or a change of angle of light is required to make apparent a slight change of color, the change is not considered appreciable.

6. REPORT

6.1 Standard sample. Colorfastness to water shall be reported as "pass" or "fail" when compared with the standard sample. If either test specimen or the transfer cloth of the test specimen shows failure when compared to comparable material of the standard sample the specimen shall be reported as failing. When failure is reported the severest departure (i.e. the actual rating "fair" or "poor"), of the change of the test specimen or staining of specific fibers of the color transfer cloth, shall be distinguished and reported.

FED. TEST METHOD STD. NO. 191A

METHOD 5630

6.2 No standard sample. Colorfastness to water shall be reported as "pass" or "fail" when the test specimen and color transfer cloth are evaluated and rated in accordance with the adjective ratings of 5.9.5. Failure of either the test specimen or the color transfer cloth to meet the adjective ratings specified in the applicable procurement document shall be reported as failure. When failure is reported the severest departure (i.e. the actual rating "fair" or "poor"), of the change of test specimen or staining of specific fibers of the color transfer cloth, shall be distinguished and reported.

7. NOTES

7.1 The perspirometers described may be purchased from Orange Machine and Manufacturing Company, 1503 Bay Avenue, Point Pleasant, NJ 08742, or Atlas Electric Devices Company, 4114 N. Ravenswood Avenue, Chicago, IL 60613.

7.2 Multifiber test cloths (color transfer cloth) and cotton cloth may be obtained from Testfabrics, Inc., P.O. Box 53, 200 Blackford Ave., Middlesex, NJ 08846.

COLORFASTNESS OF TEXTILE MATERIALS TO SALT WATER AND SOAP

1. SCOPE

1.1 This method is intended for determining the colorfastness of textile materials to salt water and soap.

2. TEST SPECIMEN

2.1 Standard sample. Unless otherwise specified in the procurement document, when a standard sample has been established, the required specimens from the sample unit of material being tested and one specimen from the standard sample shall be as follows.

2.1.1 Cloth. A rectangle approximately 2 inches by 4 tithes (51 mm by 102 mm).

2.1.2 Yarn, thread, light cordage, tape, webbing and braid. Sufficient amount of the applicable material that can be arranged to form a rectangle 2 inches by 4 inches (51 mm by 102 mm).

2.2 No standard sample. Unless otherwise specified in the procurement document, when a standard sample has not been established, the required specimens from the sample unit of the material to be tested shall be as specified in 2.1.1 and 2.1.2. One additional specimen shall be taken from each sample unit of the material to be tested and shall be retained, untested, for comparison. All specimens shall be taken from adjacent areas of the sample unit.

3. NUMBER OF DETERMINATIONS

3.1 Unless otherwise specified in the procurement document, one specimen shall be tested from each sample unit.

4. APPARATUS, REAGENTS AND METHOD CITED

4.1 Apparatus.

4.1.1 Beaker. Approximately 100 ml capacity.

4.1.2 Hand-iron. A hand-iron weighing approximately 6 pounds (2.7 kg) and maintained at a temperature of 275° to 302°F (135° to 150°C).

4.1.3 Color transfer cloth. A test cloth with a 6-fiber repeat made up of equal bars of acetate, cotton, nylon 66, polyester (polyethylene terephthalate) acrylic and wool. Each 6-fiber repeat shall measure approximately 2 inches (51 mm) and shall be separated by a waste filling stripe (see 7.1).

METHOD 5632

4.1.4 White thread.

4.1.5 Bleached, desized, cotton cloth (see 7.1).

4.2 Reagents.

4.2.1 Sodium chloride (NaCl).

4.2.2 Magnesium chloride, anhydrous (Mg Cl₂).

4.2.3 Soap. The soap shall conform to P-S-617, Soap, Toilet (For Soft and Hard Water Use).

4.3 Method cited.

Method 9010, Shade Matching of Textile Materials; Visual Method.

5. PROCEDURE

5.1 Standard sample. When a standard sample has been established, one specimen of the standard sample shall be tested at the same time and under the same conditions as the specimen of the material being tested.

5.2 No standard sample. When a standard sample has not been established, one specimen from each sample unit to be tested shall be retained, untested, for comparison.

5.3 Unless otherwise specified in the procurement document, a 2 inch (51 mm) square of the 6-fiber color transfer cloth shall be sewn with white thread to one corner of the test specimen or may be attached by some other suitable means. A 2-inch (51 mm) square of the color transfer cloth shall also be attached to one corner of the specimen from the standard sample when it is used for comparison.

5.4 The specimen assembly shall then be immersed for one hour at room temperature in a solution containing 3 percent sodium chloride, 0.5 percent magnesium chloride and 1 percent soap with occasional agitation.

5.5 The specimen assembly shall then be removed from the solution and the specimen separated from the color transfer cloth and dried out of contact with each other by pressing between clean white cotton cloths with a hand-iron at a temperature of 275° to 302°F (135° to 150°C).

5.6 Evaluation.

5.6.1 Evaluation shall be conducted in accordance with Method 9010.

METHOD 5632

5.6.2 The color change of the test specimen and the staining of the color transfer cloth shall be evaluated separately to determine the colorfastness to salt water and soap.

5.6.3 After testing evaluate only that stain evident on the stripe of the multi-fiber test cloth that is the same fiber or similar chemical nature as that of the dyed fabric (i.e., wool stripe for dyed wool; acetate stripe for dyed acetate; cotton stripe for either dyed cotton or viscose, and nylon stripe for both nylon and polyester). When dyed fabric or systems of unknown fiber combinations are involved, evaluate the total staining on all bars of the transfer cloth. The degree of stain shall be recorded for each individual stripe.

5.6.4 Standard sample. The color change exhibited by the tested specimen when compared to the untested specimen retained shall be evaluated against the color change exhibited by the tested standard when compared to the untested standard retained. Unless otherwise specified, the staining of the color transfer cloth of the specimen shall be evaluated against the staining of the color transfer cloth of the standard.

5.6.4.1 Specimen.

Pass : Color change equal to or less than that of the standard sample.

Fail: Color change greater than that of the standard sample.

5.6.4.2 Color transfer cloth.

Pass: Staining equal to or less than that attached to the standard sample.

Fail: Staining greater than that attached to the standard sample.

5.6.5 No standard sample. When a standard sample has not been established, evaluation of the test specimen for change in color and staining by its attached color transfer cloth shall be rated as follows:

5.6.5.1 Test specimen when compared to the specimen retained untested for comparison and color transfer cloth evaluated according to the degree of staining shall be rated as:

Excellent: No perceptible color change and staining.

Good: Perceptible but not an appreciable change in color and staining.

METHOD 5632

- Fair: Appreciable but not an objectionable change in color and staining.
Poor: Objectionable change in color and staining.

"Appreciable change in color" means a change that is immediately noticeable in comparing the test specimen with the original sample for comparison. If closer inspection or a change of angle of light is required to make apparent a slight change of color, the change is not considered appreciable.

6. REPORT

6.1 Standard sample. Colorfastness to salt water and soap shall be reported as "pass" or "fail" when compared with the standard sample. If either the test specimen or the transfer cloth of the test specimen shows failure when compared to comparable material of the standard sample, the specimen shall be reported as failing. When failure is reported the severest departure (I.e. the actual rating "fair" or "poor"), of the change of the test specimen or staining of specific fibers of the color transfer cloth, shall be distinguished and reported.

6.2 No standard sample. Colorfastness to salt water and soap shall be reported as "pass" or "fail" when the test specimen and color transfer cloth are evaluated and rated in accordance with the adjective ratings of 5.6.5. Failure of either the test specimen or the color transfer cloth to meet the adjective rating specified in the applicable procurement document shall be reported as failure. When failure is reported, the severest departure (i.e. the actual rating "fair" or "poor"), of the change of test specimen or staining of specific fibers of the color transfer cloth, shall be distinguished and reported.

7. NOTES

7.1 Multifiber test cloth (color transfer cloth) and cotton cloth may be obtained from Test Fabrics, Inc., P.O. Box 53, 200 Blackford Ave., Middlesex, NJ 08846.

COLORFASTNESS OF TEXTILE MATERIALS TO DRY AND
WET HEAT (HOT PRESSING)

1. SCOPE

1.1 This method is intended for determining the colorfastness of textiles when subjected to a normal dry or wet pressing procedure.

2. TEST SPECIMEN

2.1 Standard sample. Unless otherwise specified in the procurement document, when a standard sample has been established, the required specimens from the sample unit of the material to be tested and one specimen from the standard sample shall be as follows:

2.1.1 Cloth. A rectangle of cloth 2 inches by 4 inches (51 mm by 102 mm).

2.1.2 Yarn. A suitable amount of yarn so held together to form a unit for testing.

2.2 No standard sample. Unless otherwise specified in the procurement document, when a standard sample has not been established, the required specimens from the sample unit of the material to be tested shall be as specified in 2.1.1 or 2.1.2. One additional specimen shall be taken from each sample unit of material to be tested and retained, untested, for comparison. All specimens shall be taken from adjacent areas of the sample unit.

3. NUMBER OF DETERMINATIONS

3.1 Unless otherwise specified in the procurement document one specimen (separate specimen) shall be tested for each required characteristic from each sample unit.

4. APPARATUS, REAGENTS AND METHOD CITED

4.1 Apparatus.

4.1.1 Hand-iron. A hand-iron weighing approximately 6 pounds (2.7 kg) and capable of maintaining a temperature from 221° to 455°F (105° to 235°C) (see 7.1).

4.1.2 Pressing pad. Pad for pressing, permeable to steam.

4.1.3 Extractor. A centrifugal extractor of the laundry type with a perforated basket approximately 11 inches (280 mm) deep by 17 inches (432 mm) in diameter, with an operating speed of approximately 1500 rpm.

METHOD 5640

4.1.4 Color transfer cloth. White cotton color transfer cloth 4 to 5 ounces per square yard (136 to 170 g/m²). The transfer cloth shall be of the same dimension or slightly larger than the specimen being tested.

4.1.5 A.A.T.C.C. Chromatic Transference Scale. This scale is to be used for evaluation in accordance with method B when specified. (see 7.2).

4.1.6 Time indicator. Stop watch or other timing device which will indicate the time in seconds.

4.2 Reagent.

4.2.1 Distilled water.

4.3 Method cited.

Method 9010, Shade Matching of Textile Materials; Visual Method.

5. PROCEDURE

5.1 Standard sample. When a standard sample has been established a specimen from the standard sample shall be pressed at the same time and under the same conditions as the specimen of the material being tested.

5.2 No standard sample. When a standard sample has not been established, one specimen from each sample unit to be tested shall be retained, untested, for comparison.

5.3 Pressing temperatures. Unless otherwise specified in the procurement document the pressing temperatures shall be as follows:

248° to 275°F (120° to 135°C)	- Acetate, Modacrylic, Vinyl.
302° to 329°F (150° to 165°C)	- Acrylic, Polyamide, Olefin.
347° to 344°F (175° to 190°C)	- Polyester, Wool.
362° to 389°F (200° to 215°C)	- Aromatic Polyamide, Cotton, Linen.

5.4 Unless otherwise specified in the procurement document, all specimens to be tested shall be conditioned in accordance with Section 4 of this standard. When required all specimens shall be cooled to room temperature at Standard Atmospheric Conditions.

5.5 Color change (dry pressing).

5.5.1 The specimen shall be placed on a pressing pad, then the hand-iron set at the required temperature (see 5.3), shall be placed on the specimen and allowed to remain for 10 seconds.

METHOD 5640

5.5.2 The specimen shall be allowed to cool to room temperature for 2 hours before evaluating.

5.6 Color transfer (dry pressing).

5.6.1 The specimen shall be placed on the pressing pad and covered with a dry white color transfer cloth then the hand-iron set at the required temperature (see 5.3), shall be placed on both and allowed to remain for 10 seconds.

5.6.2 The specimen and the white color transfer cloth shall be allowed to cool to room temperature for 2 hours before evaluating.

5.7 Color transfer (wet pressing).

5.7.1 The specimen and the white color transfer cloth shall be thoroughly wet out in distilled water at room temperature and the excess water removed by centrifuge extraction.

5.7.2 Immediately after removing the excess water the specimen shall be placed on the pressing pad and covered with the moistened white color transfer cloth, then the hand-iron set at the required temperature (see 5.3), shall be placed on both and allowed to remain for 10 seconds.

5.7.3 The specimen and the white color transfer cloth shall be allowed to cool to room temperature for 2 hours before evaluating.

5.8 Evaluation.

5.8.1 Evaluation shall be conducted in accordance with Method 9010.

5.8.2 The color change of the test specimen and the staining of the color transfer cloth shall be evaluated separately to determine the colorfastness to hot pressing (dry and wet).

5.8.3 Color change (dry and wet pressing).

5.8.3.1 Standard sample. The color change exhibited by the tested specimen when compared to the untested specimen retained shall be evaluated against the color change exhibited by the tested standard when compared to the untested standard retained. Unless otherwise specified, the staining of the color transfer cloth of the specimen shall be evaluated against the staining of the color transfer cloth of the standard.

5.8.3.1.1. Specimen.

Pass: Color change equal to or less than that of the standard sample.

Fail: Color change. greater than that of the standard sample.

METHOD 5640

5.8.3.1.2 Color transfer cloth.

Pass: Staining equal to or less than that of the standard sample.
Fail: Staining greater than that of the standard sample.

5.8.3.2 No standard sample. When a standard sample has not been established, the test specimen shall be compared to the untested specimen retained for comparison and shall be rated as follows:

Excellent: No perceptible change in color.
Good: Perceptible but not an appreciable change in color.
Fair: Appreciable but not an objectionable change in color.
Poor: Objectionable change in color.

5.8.3.3 No standard sample. When a standard sample has not been established, the staining of the white color transfer cloth shall be rated in accordance with Method A or Method B, whichever is specified in the procurement document.

5.8.3.3.1 Method A, direct comparison. Any staining of the white color transfer cloth shall be compared to clean, unstained, white color transfer cloth and rated as follows:

Excellent: No perceptible staining.
Good: Perceptible but no appreciable staining.
Fair: Appreciable but no objectionable staining.
Poor: Considerable and objectionable staining.

"Appreciable change in color or staining" means a change in color or staining that is immediately noticeable in comparing the test specimen or white color transfer cloth with a sample of the original material. If closer inspection or a change of angle of light is required to make more apparent a slight change in color or staining, the change of color or staining is not considered appreciable.

5.8.3.3.2 Method B, A.A.T.C.C. Chromatic Transference Scale. Any staining of the white color transfer cloth shall be compared with the A.A.T.C.C. chromatic Transference Scale and rated as follows:

Excellent: Staining rated numerically greater than 3.5.
Good: Staining rated numerically greater than 2.5.
Fair: Staining rated numerically greater than 1.5.
Poor: Staining rated numerically less than 1.5.

During the evaluation, the white color transfer cloth shall be backed by 3 layers of clean unstained white color transfer cloth.

METHOD 5640

6. REPORT

6.1 Standard sample.

6.1.1 Colorfastness (color change) to dry pressing shall be reported as "pass" or "fail" when the test specimen is compared to the standard sample. If the test specimen shows failure when compared to comparable material of the standard sample, the specimen shall be reported as failing.

6.1.2 Colorfastness (color transfer) to dry and wet pressing shall be reported as "pass" or "fail" when the white color transfer cloth from the test specimen is compared with the white color transfer cloth from the standard sample. If the white color transfer cloth shows failure when compared to comparable material of the standard sample, the white color transfer cloth shall be reported as failing.

6.1.3 When failure is reported, the severest departure (i.e. the actual rating, "fair" or "poor"), of the test specimens or staining of the white color transfer cloth, shall be distinguished and reported.

6.2 No standard sample.

6.2.1 Colorfastness (color change) to dry pressing shall be reported as "pass" or "fail" when the test specimen is compared with the untested specimen and rated in accordance with the adjective ratings of 5.8.3.2 Failure of the test specimen to meet the adjective rating specified in the applicable procurement document shall be reported as failing.

6.2.2 Colorfastness (color transfer) to dry and wet pressing shall be reported as "pass" when the color transfer cloth is evaluated and rated in accordance with Methods A or B (5.8.3.3) whichever is required in the procurement document. Failure of the white color transfer cloth to meet the adjective rating specified in the applicable procurement document shall be reported as failing.

6.2.3 When failure is reported, the severest departure (i.e. the actual rating, "fair" or "poor"), of the test specimen or staining of the white color transfer cloth, shall be distinguished and reported.

7. NOTES

7.1 Weights should be added if the weight of the hand iron is less than 6 pounds (2.7 kg).

7.2 A.A.T.C.C. Chromatic Transference Scale may be purchased from: American Association of Textile Chemists and Colorists, P.O. Box 12215, Research Triangle Park, NC 27709.

METHOD 5642
July 20, 1978

COLORFASTNESS OF TEXTILE MATERIALS TO
DRY HEAT (SUBLIMATION)

1. SCOPE

1.1 This method is intended for determining the colorfastness of textile materials to dry heat.

2. TEST SPECIMEN

2.1 Standard sample. Unless otherwise specified in the procurement document, when a standard sample has been established, the required specimens from the sample unit of the material to be tested and one specimen from the standard sample shall be as follows:

2.1.1 Cloth. A rectangle of cloth 2 by 4 inches (51 by 102 mm).

2.1.2 Yarn and thread. Not less than 1 g and not more than 3 g of yarn so held together as to form a unit for testing.

2.1.3 Tapes, braids and narrow fabrics. A rectangle of the specimen 2 by 4 inches (51 by 102 mm). When the full width of the specimen is not 2 inches (51 mm) several lengths of the material shall be placed adjacent and parallel.

2.2 No standard sample. Unless otherwise specified in the procurement document, when a standard sample has not been established, the required specimens from the sample unit of the material to be tested shall be as specified in 2.1.1, 2.1.2 or 2.1.3. One additional specimen shall be taken from each sample unit of material to be tested and shall be retained, untested, for comparison. All specimens shall be taken from adjacent areas of the sample unit.

3. NUMBER OF DETERMINATIONS

3.1 Unless otherwise specified in the procurement document, one specimen shall be tested from each sample unit.

4. APPARATUS

4.1 Heating arrangement providing even heat transfer by close contact to both sides of the specimen. This device shall be capable of maintaining selected temperatures within a tolerance of $\pm 6^{\circ}\text{F}$ ($\pm 3^{\circ}\text{C}$) in the range of 300° through 426°F (149° through 219°C) and of maintaining sufficient pressure on the composite specimen to assure intimate contact between the test specimen and the heating medium (see 7.1).

FED. TEST METHOD STD. NO. 191A

METHOD 5642

4.2 Color transfer cloth. Two pieces of Multifiber Test Fabric No. 10 consisting of acetate, cotton, nylon 66, polyester (polyethylene terephthalate), acrylic and wool (see 7.2).

4.3 Time indicator. Stop watch or other timing device which will indicate the time in seconds.

4.4 Gray Scale for Staining (see 7.3).

5. PROCEDURE

5.1 Standard sample. When a standard sample has been established a specimen from the standard shall be subjected to the same conditions of testing as the specimen of the material being tested.

5.2 No standard sample. When a standard sample has not been established, one specimen from each sample unit to be tested shall be retained, untested, for comparison.

5.3 Preparation of specimen. Place the specimen between the two pieces of the Multifiber Test Fabric No. 10 measuring 2 by 4 inches (51 by 102 mm), so that the specimen will be in contact with all the bands of the test cloth, to form a composite specimen.

5.4 Unless otherwise specified in the procurement document, place the composite specimen in the heating device for thirty seconds at the specified temperature.

5.4.1 One or more of the following temperatures shall be used to perform the test. The applicable procurement document shall specify the proper temperature or temperatures for that material.

1. 300° ± 6°F (149° ± 3°C)
2. 325° ± 6°F (163° ± 3°C)
3. 351° ± 6°F (177° ± 3°C)
4. 376° ± 6°F (191° ± 3°C)
5. 401° ± 6°F (205° ± 3°C)
6. 426° ± 6°F (219° ± 3°C)

5.5 Remove the composite specimen from the heating device and separate components for evaluation.

5.6 Evaluation.

5.6.1 The color change of the test specimen and the staining of the color transfer cloth shall be evaluated separately to determine the colorfastness to dry heat.

FED. TEST METHOD STD. NO. 191A

METHOD 5642

5.6.2 Color change.

5.6.2.1 Standard sample. The color change exhibited by the tested specimen when compared to the untested specimen retained shall be evaluated against the color change exhibited by the tested standard when compared to the untested standard retained. Unless otherwise specified, the staining of the color transfer cloth of the specimen shall be evaluated against the staining of the color transfer cloth of the standard.

Pass: Color change equal to or less than that of the standard sample.

Fail: Color change greater than that of the standard sample.

5.6.2.2 No standard sample. When a standard sample has not been established, the test specimen shall be compared to the untested specimen retained for comparison and shall be rated as follows:

Excellent: No perceptible change in color.

Good: Perceptible but not an appreciable change in color.

Fair: Appreciable but not an objectionable change in color.

Poor: Objectionable change in color.

5.6.3 Color transfer.

5.6.3.1 Standard sample. When a standard sample has been established, the color transfer cloth from the specimen shall be compared with the color transfer cloth from the standard sample and rated as follows:

Pass: Staining equal to or less than that of the standard sample.

Fail: Staining greater than that of the standard sample.

5.6.3.2 When a standard sample has not been established the test color transfer cloth shall be compared with the Gray Scale for Staining and rated as follows:

Excellent: Staining rated numerically greater than 4.5.

Good: Staining rated numerically greater than 3.5.

Fair: Staining rated numerically greater than 2.5.

Poor: Staining rated numerically less than 2.5.

6. REPORT

6.1 Standard sample.

6.1.1 Colorfastness (color change) to dry heat shall be reported as "pass" or "fail" when the test specimen is compared to the standard sample.

METHOD 5642

6.1.2 Colorfastness (staining) to dry heat shall be reported as "pass" or "fail" when the color transfer cloth from the test specimen is compared with the color transfer cloth from the standard sample.

6.1.3 When failure is reported, the severest departure (i.e. the actual rating "fair" or "poor"), of the change of the test specimen or staining of specific fibers of the color transfer cloth, shall be distinguished and reported.

6.2 No standard sample.

6.2.1 Colorfastness (color change) to dry heat shall be reported as "pass" or "fail" when the test specimen is compared with the untested specimen and rated in accordance with the adjective ratings of 5.6.2.2.

6.2.2 Colorfastness (staining) to dry heat shall be reported as "pass" or "fail" when the color transfer cloth is rated in accordance with the adjective ratings of 5.6.3.2.

6.2.3 When failure is reported, the severest departure (i.e. the actual rating, "fair" or "poor"), of the change of test specimen or staining of specific fibers of the color transfer cloth, shall be distinguished and reported.

7. NOTES

7.1 The apparatus described (Scorch Tester) may be obtained from the Atlas Electric Devices Co., 4114 N. Ravenswood Avenue, Chicago, IL 60613.

7.2 The Multifiber Test Fabric No. 10 (color transfer cloth) may be obtained from Testfabrics, Inc., P.O. Box 53, 200 Blackford Ave., Middlesex, NJ 08846.

7.3 Gray Scale for Staining may be obtained from the American Association of Textile Chemists and Colorists, P.O. Box 12215, Research Triangle Park, NC 27709.

METHOD 5651
July 20, 1978

CROCKING OF WOVEN AND KNITTED CLOTH; STANDARD SAMPLE;

MUNSELL SCALE METHOD

1. SCOPE

1.1 This method is intended for determining the resistance of woven or knitted cloth to crocking. Crocking in this case refers to the transfer of coloring matter from one cloth to another cloth with which it may come in contact. This method is applicable to cloth of all fibers whether dyed, printed, impregnated, or otherwise colored. The method is particularly applicable to cloth of solid color, although variegated cloth may be tested if the colored area is of sufficient size. The method also includes provisions for testing the crocking of white or light functionally finished cloths against dark colored cloth when required by the cloth specification. Wet and dry crocking may be determined by this method. Unless otherwise specified in the procurement document, both wet and dry crocking are considered in rating the resistance to crocking as determined by this method.

2. TEST SPECIMEN

2.1 Standard sample. Unless otherwise specified in the procurement document, when a standard sample has been established, the required specimens from the sample unit of the material to be tested and one specimen from the standard sample shall be as follows:

2.1.1 Cloth. Unless otherwise specified, the specimen shall be a rectangle of cloth 8 inches by 4 inches (203 mm by 102 mm). The long dimension shall be parallel to the warp.

2.1.2 Tapes and laces. For narrow tapes and laces, the specimen shall be held in the test position by any suitable means. For example, lace may be attached firmly to a piece of white cotton cloth. When the individual item is too narrow for the size of the crocking finger, specimens of the material shall be laid adjacent and closely packed so that the full crocking area of the finger is covered.

2.2 No standard sample. Unless otherwise specified in the procurement document, when a standard sample has not been established, the required specimen from the sample unit of the material to be tested shall be as specified in 2.1.1 and 2.1.2. One additional specimen shall be taken from each sample unit of material to be tested and retained, untested, for comparison. All specimens shall be taken from adjacent areas of the sample unit.

3. NUMBER OF DETERMINATIONS

3.1 Unless otherwise specified in the procurement document, one specimen shall be tested from each sample unit.

FED. TEST METHOD STD. NO. 191A

METHOD 5651

4. APPARATUS

4.1 Crockmeter. A crockmeter consisting of a wooden base or equivalent, upon which a sliding arm operated by a crank shall be fixed in such a manner as to slide back and forth in a straight line with a stroke of 4 inches (102 mm). The arm shall have a flat-ended-cylindrical finger, 5/8 inch (16 mm) in diameter, which shall exert a total force of 2 pounds (9 N) on the cloth clamped to the base (see 7.1).

4.2 Color transfer cloth.

4.2.1 White. Unless otherwise specified in the procurement document the color transfer cloth shall be a bleached, desized, 80 by 84 (32 by 33 yarns/cm) combed yarn cotton lawn cloth, and cut into 2-inch (51 mm) squares. The cloth shall contain no bluing or optical bleach (see 7.4).

4.2.2 Blue. When specified, the color transfer cloth shall be vat dyed, 80 by 84 (32 by 33 yarns/cm) combed yarn cotton lawn cloth, Blue 186, and cut into 2-inch (51 mm) squares (see 7.5).

4.3 Evaluation scales.

4.3.1 Unless otherwise specified in the procurement document, one of the following evaluation scales shall be provided.

4.3.1.1 Munsell Neutral Value Scale. Munsell Neutral Value Scale (1 to 9), for use in evaluating fire, weather, and water resistant cloths or similarly impregnated cloth (see 7.3).

4.3.1.2 Munsell Color Chips. Munsell Color Chips of hues red, yellow, green, blue and purple, in values 6 to 9 with 2 steps of chroma, for use in evaluating dyed cloths (see 7.3).

4.3.1.3 A.A.T.C.C. Color Transference Chart. (See 7.6)

4.4 Wringer. A household type wringer equipped with smooth rubber squeeze rolls 2-1/8 to 2-1/2 inches (54 mm to 64 mm) in diameter and not less than 11 inches (279 mm) or more than 16 inches (406 mm) long. The rubber rolls shall have a Shore durometer hardness of 70 to 80 (A scale). The load exerted on the specimen shall be applied uniformly by means of a dead weight attached to the top roller. The total load of the roller, means of attaching the weight, and the weight itself shall be 60 pounds (27 kg). The rolls shall be power driven at such a speed that the specimen shall pass through the rolls at the rate of 1 inch (25 mm) per second.

4.5 A spiral clip or other device for holding the crock cloth tight over the flat end of the cylindrical finger.

METHOD 5651

4.6 Distilled water. Distilled water for wetting the crock cloth for wet crocking.

4.7 Blotting paper. The blotting paper dimensions shall be 4 inches by 8 inches (102 mm by 203 mm) (see 7.2).

5. PROCEDURE

5.1 Standard sample. When a standard sample has been established for color-fastness to crocking, Method A shall be used for evaluating the resistance to crocking (see 5.5).

5.1.1 No standard sample. When a standard sample has not been established, Method B shall be used for evaluating the resistance to crocking.

5.2 When a standard or comparison sample has been established, a specimen from the standard or comparison sample shall be tested under the same conditions as the specimen undergoing the test.

5.3 Unless otherwise specified in the procurement document, the face of the cloth shall be against the finger of the crockmeter. In the case of coated cloths, the coated side shall be against the finger of the crockmeter.

5.4 Dry crocking.

5.4.1 The specimen and the "dry" crock cloth shall be brought to moisture equilibrium under standard conditions, in accordance with Section 4 of this standard.

5.4.2 The specimen shall be placed on the abrasive cloth-covered base of the crockmeter so that the finger contacts the specimen about 1 inch (25 mm) from the 8-inch (203 mm) warp edge of the specimen.

5.4.3 The finger with the cloth attached shall be placed on the surface of the specimen and moved back and forth on the specimen at the approximate rate of 1 cycle per second. Ten cycles (20 strokes) shall constitute the test.

5.5 Wet crocking.

5.5.1 The test shall be repeated on an area adjacent to the previous test using a new crock cloth "wet" with distilled water. For wetting, the crock cloth shall be completely saturated and squeezed to remove excess water, placed between 2 sheets of blotting paper and passed through the wringer. The moisture pickup shall be 65 ± 5 percent based on the conditioned weight of the crock cloth. The crock test shall be performed immediately after wringing.

METHOD 5651

5.6 Evaluation. Staining of the dry and wet crock cloths shall be considered in rating the resistance to crocking.

5.6.1 Method A, standard sample. The "crock" obtained from the test specimen shall be compared with the "crock" obtained in testing the specimen from the standard sample and rated as follows:

- Pass: Equal or superior to the standard sample in resistance to crocking.
- Fail: Inferior to the standard sample in resistance to crocking.

5.6.2 Method B, no standard sample. The coloration imparted to the test crock cloth as a result of contact with the test specimen shall be compared with the Munsell Neutral Value Chips or Munsell Color Chips as required, or A.A.T.C.C. Color Transference Chart, and unless otherwise specified (see 6.4) evaluated as follows:

5.6.2.1 When white crock cloth is required.

- Excellent: No perceptible staining of the white crock cloth.
- Good: Slight staining of the white crock cloth. Not to be numerically lower than Munsell Value 8.5.
- Fair: Appreciable, but not objectionable, staining of the white crock cloth. Not to be numerically lower than Munsell Value 6.5.
- Poor: Objectionable staining of white crock cloth, numerically lower than Munsell Value 6.5.

5.6.2.2 When blue crock cloth is required.

- Excellent: No perceptible staining of the blue crock cloth.
- Good: Slight staining of the blue crock cloth. Not to be numerically higher than Munsell Value 4.5.
- Fair: Appreciable, but not objectionable, staining of the blue crock cloth. Not to be numerically higher than Munsell Value 6.5.
- Poor: Objectionable staining of the blue crock cloth. During evaluation, the crock cloth of the test specimen (dried in atmospheric conditions in the case of the wet test) should be backed by 3 layers of the crock cloth.

"Appreciable change in color" means a change which is immediately noticeable in comparing the tested specimen with the original comparison specimen. If closer inspection or a change of angle of light is required to make apparent a slight change in color, the change is not considered appreciable.

METHOD 5651

6. REPORT

6.1 Standard sample. When a standard sample has been established, the resistance to crocking shall be reported as "pass" or "fail".

6.2 No standard sample. When a standard sample has not been established, the resistance to crocking shall be reported as "pass" or "fail", unless otherwise specified in the procurement document. When failure is reported, the adjective rating, "good", "fair", or "poor", shall also be reported.

6.3 When specified in the procurement document, the resistance to crocking shall be reported as the value nearest to one of the Munsell Values (4.3.1.1 and 4.3.1.2).

6.4 The dry and wet crocking resistance of each sample unit shall be reported separately.

7. NOTES

7.1 The crockmeter may be purchased from the Executive Secretary, A.A.T.C.C. National Headquarters, P.O. Box 12215, Research Triangle Park, NC 27709, and Atlas Electric Devices Co, 4114 North Ravenswood Ave., Chicago, IL 60613.

7.2 The blotting paper is available from:

James River Paper Company
P.O. Box 2218
Richmond, VA 23217

7.3 The Munsell Neutral Value Scale and the Munsell Color Chips may be purchased from the Munsell Color Co., 2441 North Calvert St., Baltimore, MD 21218.

7.4 The white crock cloth which meets the requirements of this method may be purchased from TestFabrics, Inc., P.O. Box 53, 200 Blackford Ave., Middlesex, NJ 08846.

7.5 The blue crock cloth may be obtained from the Defense Personnel Support Center, 2800 South 20th Street, Philadelphia, PA 19191.

7.6 The Color Transference Chart may also be purchased from A.A.T.C.C. National Headquarters.

METHOD 5660
July 20, 1978

COLORFASTNESS TO LIGHT OF TEXTILE MATERIALS;

ACCELERATED METHOD

1. SCOPE

1.1 This method is intended for determining the colorfastness of textile materials to light in a Carbon-Arc Fading apparatus.

2. TEST SPECIMEN

2.1 Standard sample. Unless otherwise specified in the procurement document, when a standard sample has been established and the length of time of exposure has been specified, one specimen from each sample unit of the material to be tested, and one specimen from the standard sample shall be as specified in 2.2.1 through 2.2.3.

2.1.1 When a standard sample has been established and length of time of exposure has not been specified, two specimens from each sample unit and two specimens from the standard sample shall be taken for testing.

2.2 The specimens for testing shall be as follows:

2.2.1 Cloth. A rectangle of cloth measuring 2-1/2 inches by 3 inches (64 mm by 76 mm) with the long dimension parallel to the warp direction.

2.2.2 Textile fibers. Fibers will be made into pads forming a rectangle measuring 2-1/2 inches by 3 inches (64 mm by 76 mm).

2.2.3 Yarns, threads, light cordage, tapes and webbing. Yarns, threads, light cordage, tapes and webbing shall be wound on white cards forming a rectangle 2-1/2 inches by 3 inches (64 mm by 76 mm) with the long dimension lengthwise of the materials being tested.

2.3 No standard sample. Unless otherwise specified in the procurement document when a standard sample has not been established, one specimen from each sample unit of the material to be tested shall be selected as in 2.1.

2.4 When more than one specimen is taken from a sample unit for testing, the specimens will be taken from adjacent material in the sample unit.

3. NUMBER OF DETERMINATIONS

3.1 Unless otherwise specified in the procurement document, one specimen shall be tested from each sample unit (see 5.2.4.3 for an exception).

FED. TEST METHOD STD. NO. 191A

METHOD 5660

4. APPARATUS AND METHOD CITED

4.1 Apparatus.

4.1.1 Carbon-arc lamp fading apparatus (see 7.4). The carbon-arc lamp fading apparatus shall conform to the following:

4.1.1.1 Vertical carbon-arc assembly mounted at the center of a vertical cylindrical framework.

4.1.1.2 The electrodes shall be carbon, one solid, 1/2 inch (13 mm) diameter and one cored 1/2 inch (13 mm) diameter, placed in the machine in the manner described in the operating instructions. If the carbons, as obtained from the supplier, tend to bind they should be ground with garnet paper so that they move freely in the machine and do not bind.

4.1.1.3 The arc shall be operated at 15 to 17 amperes 60-cycle alternating current with an arc voltage of 135 to 145 volts and a line voltage of 208 to 250 volts.

4.1.2 Clear glass globe of No. 9200 Pyrex, or equal, for enclosing the arc.

4.1.3 Cylindrical framework provided with specimen holders in which the specimen is suspended vertically and normally to radiation from the arc with the specimen at a radial distance of 10 inches (254 mm) from the center of the arc with no part over 5 inches (127 mm) above or below the arc.

4.1.3.1 The framework shall revolve 1 to 4 revolutions per minute about the arc.

4.1.4 The black panel thermometer unit shall consist of 20 gage stainless steel panel, 2-3/4 by 5-7/8 inches (70 to 150 mm) to which is fastened a stainless steel bimetallic did-type thermometer. The face of the panel with the thermometer is at the same distance from the arc as the surface of the specimen.

4.1.5 Chamber temperature shall be controlled by regulating the temperature of a constant volume of air flowing across the specimens. An atomizing unit shall control the addition of moisture to the air prior to its entry into the test chamber in such manner that the relative humidity within the test chamber may be controlled within + 5 percent in the range of 30 percent to 50 percent. Black panel temperature shall be maintained at 145° ± 6°F (63° ± 3°C).

4.2 Determination of Standard Fading Hours. Standard Light-Sensitive Paper for determining the fading rate of the fading apparatus. The Standard Light-Sensitive Paper shall be the latest lot obtainable from the National Bureau of Standards. It is blue colored paper 2-5/8 by 3-1/8 inches (67 by 79 mm) in size which is used in conjunction with a booklet containing the identical paper which

METHOD 5660

has been exposed in the Bureau's Master Fading Lamp. A comparison of the faded paper against samples in the booklet establishes the Standard Fading Hours of Exposure of the specimen. The NBS standard paper is suitable for calibrating fading hours during the period permitted by one trim of carbons.

4.3 National Bureau of Standards booklet of standard exposure of identical Standard Light-Sensitive Paper. The booklet contains a large number of standard exposures for varying times produced in the Bureau's Master Fading Lamp which has been adjusted to give twenty Standard Fading Hours of Exposures in a twenty hour running period (see 7.2).

4.4 Method cited.

Method 9010, Shade Matching of Textile Materials; Visual Method.

5. PROCEDURE

5.1 Preparation of specimen.

5.1.1 For specimens containing other than wool fiber. The specimens shall be conditioned a minimum of four hours at standard conditions in accordance with Section 4 of this Standard prior to being exposed in the machine.

5.1.2 For wool specimens and specimens containing blends of wool fiber. The specimens (test specimen and specimen of standard sample when applicable) shall be prepared as follows prior to exposure: The specimen shall be laid flat, without folding, in a sink or similar apparatus, and water at a temperature of 75° to 86°F (24° to 30°C) applied in a fine spray against it until it is thoroughly wet. No wetting agent shall be used. The specimen shall be turned over and the reverse side sprayed until it is saturated. The specimen shall then be extracted and then spread out without distortion on a drying tray to remove wrinkles and permitted to air dry. The drying time may be decreased by placing the specimen on the tray in moving air from a fan or it may be placed in a drying oven at a temperature not to exceed 180°F (82°C). Pressing of the specimens is prohibited. After drying the specimen shall be conditioned for a minimum of four hours under standard conditions prior to being exposed in the machine.

5.2 Preparation prior to Installing specimens.

5.2.1 The globe inclosing the carbon-arc shall be checked and cleaned at least once in every 24 hours of operating time. The globe shall be discarded after 2000 hours of operation or when pronounced discoloration, cracking, or chipping develops, whichever occurs first.

5.2.2 Clean humidifier wicks and air filter.

METHOD 5660

5.2.3 Install a new trim of wicks in accordance with operating instructions.

5.2.4 Mount specimen on specimen holders using no backing material of any kind, taking care to insure that the front and back covers make good contact with the specimen. The specimen holder cover and back clip should be fastened reasonably tight to yield a sharp line of demarcation between exposed and unexposed areas, but should not compress the specimens unnecessarily. Specimens shall be mounted for testing as follows:

5.2.4.1 No standard sample. When no standard sample is available one holder containing the test specimen and one holder containing the calibration paper shall be prepared. Additional holders may be prepared with other test specimens of filler materials for use in completely filling all available spaces on the sample holder rack in the machine.

5.2.4.2 Standard sample. When a standard sample is available for comparison purposes and the number of standard hours of exposure is specified one holder containing the test specimen, one holder containing the standard sample and one holder containing calibration paper shall be prepared. When several specimens of the same material and shade are being exposed at the same time and for the same exposure time, one specimen of the standard and one calibration paper shall suffice for all specimens. Additional holders may be prepared with other test specimens of filler materials for use in completely filling all available spaces on the sample holder rack in the machine. Standard sample test specimen and calibration paper shall be mounted in adjacent holders in the same level to insure uniform radiation for all specimens.

5.2.4.3 When a standard sample is available for comparison purposes and the number of standard hours is not specified; two holders containing test specimens, two holders containing standard samples and one holder containing the calibration paper shall be prepared. Remaining holders shall be prepared with other test specimens or filler materials to insure that all specimen holders are filled.

5.3 Installation of specimen holders in machine. Place the filled specimen holders in the specimen rack with the holders supported both top and bottom in proper vertical alignment. A small displacement of the specimen toward or away from the lamp may lead to too much or too little fading. Insure that the rack is completely filled with specimen holders. When utilizing a standard sample, place the standard and the test specimen adjacent to one another on the rack.

5.4 Close the door and set the timer for 20 clock hours or for that number of clock hours which are known to be equivalent to 20 standard fading hours, and start the machine. Check controls to insure that the machine is functioning properly. Unless otherwise required by the exposure time specified in the procurement document, the machine shall be operated in 20 hour increments with new calibration paper and a new trim of the carbons inserted at the end of each 20 hour period (see 7.5).

FED. TEST METHOD STD. NO. 191A

5.5 Length of exposure.

5.5.1 No standard sample. Unless otherwise specified in the procurement document, when a standard sample has not been established or is not available for comparison, the test specimen shall be exposed for 40 standard fading hours. At the end of each 20 hour exposure period a new piece of calibration paper shall be placed in the machine. The exposed calibration paper shall be retained and evaluated in accordance with instructions contained in 5.6.

5.5.2 Standard sample. When a standard sample has been established and is available for comparison purposes and the number of standard fading hours of exposure is specified, the test specimen and the specimen from the standard sample shall be exposed for the specified number of standard fading hours. At the end of each 20 hour exposure period a new piece of calibration paper shall be placed in the machine. The exposed calibration paper shall be retained and evaluated in accordance with instructions contained in 5.6.

5.5.3 When a standard sample has been established and is available for comparison purposes and the number of standard fading hours of exposure is not specified, one test specimen from the material undergoing test, one specimen from the standard sample, and one specimen of the calibration paper shall be exposed. At the end of 20 standard fading hours of exposure, the specimens shall be removed from the fading lamp and the test specimens and specimens of the standard sample compared with the unexposed specimen for an appreciable change in color as described in 5.7.2.

5.5.4 The calibration paper shall be replaced with another unexposed paper (the exposed paper being retained) and all the specimens replaced in the machine. This procedure shall be repeated every 20 standard fading hours of exposure.

5.5.5 When an appreciable change in color is evident in either sample being evaluated or the standard sample, the specimens shall be again placed in the fading lamp. Exposure shall be continued for an additional number of hours equal to the number of hours at which the "appreciable change in color" was apparent, and the test is terminated at the end of that period.

5.5.6 Specimens which do not show an "appreciable change in color" until 80 or more standard fading hours of exposure shall be returned to the fading lamp for a total exposure period not exceeding 140 standard fading hours, at which time the test shall be terminated.

5.5.7 At the end of the total exposure period, the test specimen and the specimen of the standard sample shall be removed from the lamp and allowed to be in the dark at room temperature for a minimum of four hours before evaluation.

METHOD 5660

5.6 Evaluation of calibration paper.

5.6.1 The exposed specimens of calibration paper after removal from the lamp shall be placed in the dark at room temperature for a minimum of one hour.

5.6.2 The exposed specimen is then compared with the standard exposure papers in the National Bureau of Standards Booklet. The comparisons shall be made with the paper grain of the Standards and control faded strips placed on the same plane, preferably in a horizontal position. The exposed parts of both the standard and the exposed control specimens should not be touched by the fingers because of the paper's sensitivity to moisture and danger of soiling (see 7.3).

5.6.3 The standard faded strip most closely approximating the exposed control paper in degree of fading should be selected, and the material shall be credited for having been exposed for the corresponding number of standard fading hours regardless of the number of hours recorded by the timing clock.

5.6.3.1 Any fading lamp may change its rate of fading from day to day. Therefore, the NBS, Standard Light-Sensitive Paper shall be used as a control in all testing, that is, the paper shall be exposed at the same time as the specimen undergoing test. In comparing the exposed control with the Standards of Fading produced in the NBS Master Lamp, it is possible to interpolate immediate differences midway between any two standards contained in the booklet.

5.6.4 The fading hours recorded for the individual control papers shall be totaled and this figure used as the total number of standard fading hours to which the material has been exposed.

5.7 Evaluation. The evaluation of the test specimen with the standard or comparison sample shall be in conformance with Method 9010.

5.7.1 Standard sample.

5.7.1.1 When a standard sample is available and the number of hours of exposure has not been established, the test specimen and the specimen of the standard sample which have been exposed for the total exposure shall be compared and the test specimen rated as follows:

Pass: Color change equal to or less than that of the standard sample.
Fail : Color change greater than that of the standard sample.

In the event that the standard sample and the test specimen reverse their relative rating from the first appreciable change in color at the end of the exposure cycle, the results at the end of the total exposure cycle shall nevertheless constitute the basis for the rating.

METHOD 5660

5.7.1.2 When a standard sample is available and the number of hours of exposure has been established, the test specimen and the specimen of the standard sample shall be compared and the test specimen rated as follows:

- Pass: Color change equal to or less than that of the standard sample.
- Fail: Color change greater than that of the standard sample.

5.7.2 No standard sample. When a standard sample has not been established, the exposed test specimen shall be compared with the unexposed specimen from the sample unit and rated as follows:

- Excellent: No perceptible change in color.
- Good: Perceptible, but not appreciable change in color.
- Fair: Appreciable, but not objectionable change in color.
- Poor: Objectionable change in color.

"Appreciable change in color" means a change that is immediately noticeable in comparing the test specimen with the original unexposed specimen. If closer inspection or a change of angle of light is required to make apparent a slight change in color, the change is not considered appreciable.

6. REPORT

6.1 Standard sample. When a standard sample has been established, color-fastness to light shall be reported as "pass" or "fail". When failure is reported, the severest departure (i.e. the actual rating, "fair" or "poor"), of the change of the test specimen, shall be distinguished and reported.

6.2 No standard sample. When no standard sample has been established, color-fastness to light shall be reported as "pass" or "fail". When failure is reported, the severest departure (i.e. the actual rating, "fair" or "poor"), of the change of the test specimen, shall be distinguished and reported.

6.3 The lot number of the National Bureau of Standard Paper for determination of the Standard Fading Hours shall be reported.

7. NOTES

7.1 Standard Light Sensitive Paper and booklet of Standard Fading Strips are prepared by and available from the National Bureau of Standards, Washington, DC 20234. Precautions must be taken to assure that the light-sensitive paper and the book fading standards are from the same lot of paper, as some variation does occur from one lot of paper to another. The book of Standard Fading Strips and the paper are appropriately marked with the lot number. To obtain the specific number of Standard Fading Hours during each 20 hour exposure period, a factor may have to be developed to convert

METHOD 5660

clock hours to Standard Fading Hours which will be different for each machine. This is accomplished by establishing the ratio of clock hours to fading hours in the evaluation of the calibration paper. As an example, if the paper exposed for 20 clock hours faded to a degree such that it was interpolated to be 18 Standard Fading Hours, the factor used to arrive at the specified number of Standard Fading Hours would be 0.9. This figure is arrived at by a ratio of $18/20 = 0.9$; Example: Assuming that a period of 100 Standard Fading Hours is specified in the procurement document, using the factor, the clock hours or running time would be arrived at as follows:

$$\text{Clock hours required} = \frac{\text{Specified Fading hours}}{\text{Factor}} = \frac{100}{0.9} = 111$$

7.2 The A.A.T.C.C. Blue Lightfastness Standard L-4 may be used to calibrate the equipment used for exposure by fading the blue standard to produce 1.5 NBS units or 4.5 MacAdam units of color difference. The calculations to determine the number of machine hours for 20 Standard Fading Hours shall be as follows:

$$\frac{\text{Clock hours to produce the Std. fade on Blue L-4} \times 20}{11}$$

7.3 As an alternative, photometric measurements may be used to evaluate the fading of the light-sensitive paper and Standard Exposure Paper.

7.4 An apparatus of the type described in this method may be obtained from the Atlas Electric Devices Co., 4114 N. Ravenswood Avenue, Chicago, IL 60613.

7.5 The total exposure time in terms of Standard Fading Hours can also be established by the use of the standard 1/8 inch (3 mm) yellow methacrylate plates dyed with Solvent Yellow #33, C.I. 47000 available from the National Bureau of Standards. The degree of change measured at 420 nm by transmission on a spectrophotometer or on a filter calorimeter equipped with a narrow band pass filter can be converted to standard fading hours by reference to the calibration curve furnished by the NBS. The plate is permitted to stay in the equipment during a full exposure period and measurements made at the end of the exposure cycle or at any intermediate point at the discretion of the individual performing the test. CAUTION: The yellow plates are only useful on carbon-arc fading equipments. They are not suitable for outdoor exposure use or in equipments with other types of light sources.

7.6 With wool-like materials in particular, the finish of the unexposed area may be altered during the exposure period due to pressure of the holding plates in the specimen holders on the fabric. Also, there is the possibility of changes due to thermal effects. When such situations are noted two courses of action are possible. One is to evaluate the exposed area against a retained but sponged portion of the fabric. The other is to re-sponge the exposed specimen and evaluate after the specimen has dried and has been conditioned. Where calorimetric methods of measurement are used in evaluation, the exposed specimen shall, in every case, be compared to the retained sponged original specimen.

FED. TEST METHOD STD. NO. 191A

METHOD 5662
July 20, 1978

COLORFASTNESS TO LIGHT OF TEXTILE MATERIALS;

NATURAL LIGHT METHOD

1. SCOPE

1.1 This method is intended for determining the colorfastness of textile materials to the fading action of natural sunlight.

2. TEST SPECIMEN

2.1 Standard sample. Unless otherwise specified in the procurement document, when a standard sample has been established, one specimen from each sample unit of the material to be tested and one specimen from the standard sample shall be as follows:

2.1.1 Cloth. A rectangle of cloth measuring 2-1/2 inches by 3 inches (64 mm by 76 mm) with the long dimension parallel to the warp direction.

2.1.2 Textile fibers. Fibers made into pads forming a rectangle measuring 2-1/2 inches by 3 inches (64 mm by 76 mm).

2.1.3 Yarn, thread, light cordage, tape, webbing, and braid. Yarn, thread, light cordage, tape, webbing, and braid shall be wound on cards having a rectangle 2-1/2 inches by 3 inches (64 mm by 76 m) with the long dimension lengthwise of the material being tested.

2.2 No standard sample. Unless otherwise specified in the procurement document, when a standard sample has not been established, one specimen from the sample unit of the material to be tested shall be as specified in 2.1.1, 2.1.2 or 2.1.3. One additional specimen shall be taken from the sample unit of material to be tested and shall be retained, unexposed, for comparison. Both specimens shall be cut from adjacent areas of the sample unit.

3. NUMBER OF DETERMINATIONS

3.1 Unless otherwise specified in the procurement document, one specimen shall be tested from each sample unit.

4. APPARATUS AND METHODS CITED

4.1 Apparatus.

METHOD 5662

4.1.1 Sunlight exposure cabinet. A suitable light exposure cabinet is one of wood, metal or other satisfactory material of any convenient size, constructed so as to allow free access of air to all test specimens and covered with window glass to protect the specimens from rain and other elements of the weather. The window glass employed must be a good grade of clear flat-drawn sheet glass, single strength, 1/16 to 3/32 inch (2 to 2.5 mm) thick, free from bubbles or other imperfections with a lower cutoff at approximately 310 nm with an increase in transmission to approximately 90 percent at 370 to 380 nm (see 7.2). The glass cover must be cleaned at least once each day. The cabinet shall be equipped with a mounting rack which supports the specimens 3 inches \pm 1/4 inches (76 mm \pm 6 mm) behind the inner surface of the glass. In order to minimize shadows due to the varying angle of the sun, the usable exposure area under the glass is limited to that of the glass cover reduced on each side by twice the distance from the glass cover to the specimen.

4.1.2 Exposure area. The cabinet shall be placed in a location unprotected from the sun and in such a position that the specimen, when in place, shall be at an angle of 45° from the horizontal and facing the equator. In the Northern Hemisphere, the surface exposed shall face the south and in the Southern Hemisphere, it shall face the north. The lowest end of the cabinet shall be at least 3 feet (1 m) above the ground level. The area under the cabinet should preferably be planted in close cut grass. Non-grassed areas shall be sloped so as to prevent excessive water retention.

4.1.3 Eppley Pyranometer or equivalent device. This instrument shall be as described in Method 5800. It is for measuring radiant energy, and shall be located at the same distance from the glass as the specimen undergoing test.

4.1.4 Means of recording the prevailing weather conditions.

4.2 Methods cited.

Method 5800, Weathering Resistance of Cloth; Natural Weathering Method.
Method 9010, Shade Matching of Textile Materials; Visual Method.

5. PROCEDURE

5.1 Standard sample. When a standard sample has been established, one specimen of the standard sample shall be exposed at the same time and under the same conditions as the specimen of the material being tested.

5.2 No standard sample. When a standard sample has not been established, one specimen from each sample unit shall be exposed and the remaining specimen retained unexposed for comparison.

5.3 Unless otherwise specified in the procurement document, the specimen shall be exposed in a nonindustrial area.

METHOD 5662

5.4 Unless otherwise specified in the procurement document, the test specimen shall be placed in the sun exposure cabinet for a period sufficient to provide a quantum of radiant energy equal to 7,500 langley (315 MJ/m²). The specimen shall remain in the exposure cabinet for 24 hours a day and not be removed until the test is completed. When the colorfastness of the standard sample is known in terms of the number of Standard Fading Hours to produce an appreciable change in color, the exposure under this method shall be 120 langley (5 MJ/m²) for each Standard Fading Hour. For example, for 40 Standard Fading Hours, the exposure should be 4,800 langley (200 MJ/m²).

5.5 The specimen shall be exposed in the cabinet facing due south (or north if exposed in the Southern Hemisphere) at an angle of 45° from the horizontal.

5.6 The specimen shall be exposed for the required period or for a time sufficient to provide a quantum of radiant energy equal to the required number of langley (MJ/m²) (see 5.4).

5.7 During the exposure period, the radiant energy shall be measured by means of the Eppley Pyranometer or equivalent instrument, and the weather conditions recorded. The pyranometer shall be placed in a cabinet similar to the one in which the samples are exposed.

5.8 At the end of the exposure period, the specimen shall be removed from the cabinet and allowed to lie in the dark at room temperature for a minimum of 4 hours before evaluation.

5.9 Evaluation. The evaluation of the test specimen with the standard or comparison sample shall be in conformance with Method 9010.

5.9.1 Standard sample. When a standard sample has been established and used in the test, the test specimen shall be compared with the standard sample and rated as follows:

Pass: Color change equal to or less than that of the standard sample.
Fail: Color change greater than that of the standard sample.

5.9.2 No standard sample. When a standard sample has not been established, unless otherwise specified in the procurement document, the test specimen shall be compared to the unexposed specimen, and rated as follows:

Excellent: No perceptible change in color.
Good: Perceptible, but not appreciable change in color.
Fair: Appreciable, but not objectionable change in color.
Poor: Objectionable change in color.

"Appreciable change in color" means a change that is immediately noticeable in comparing the tested specimen with the original sample for comparison. If closer inspection or a change of angle of light is necessary to make apparent a slight change in color, the change is not considered appreciable.

METHOD 5662

6. REPORT

6.1 The location of the exposure, town and state, and whether or not the area is nonindustrial shall be reported.

6.2 The total radiation in langley (MJ/m²) to which the specimen was exposed shall be reported.

6.3 Standard sample. When a standard sample has been established, colorfastness to light shall be reported as "pass" or "fail". When failure is reported, the severest departure (i.e. the actual rating, "fair" or "poor"), of the change of the test specimen shall be distinguished and reported.

6.4 No standard sample. When a standard sample has not been established, unless otherwise specified in the procurement document, colorfastness to light shall be reported as "pass" or "fail". When failure is reported, the severest departure (i.e. the actual rating, "fair" or "poor"), of the change of the test specimen shall be distinguished and reported.

7. NOTES

7.1 A test cabinet constructed to meet these specifications is available from: Atlas Electric Devices Co., 4114 N, Ravenswood Avenue, Chicago, IL 60613, or William Harrison & Co., 4595 East 10th Court, Hialeah, FL 33013.

7.2 Window glass of the desired qualities is available from the following dealers: Libbey-Owens-Ford Glass Co., Flat-Drawn Sheet Glass, Single strength, Quality B, and Pittsburgh Plate Glass Co., Pennvernon Sheet Glass, Single Strength, Quality B, are considered suitable. The glass is described in the manufacturers' catalogs as transmitting a minimum of 77 percent ultraviolet, 90 percent Illuminant C (average daylight) and 85 percent total radiation. Transmittance curves of two panels secured from dealer stock showed no transmittance below 310 nm, close to a straight line rise to 90 percent at 370-380 nm and 90 percent transmittance in the visible regions to 700 nm.

METHOD 5671
July 20, 1978

COLORFASTNESS OF TEXTILE MATERIALS TO WEATHER;

ACCELERATED WEATHERING METHOD

1. SCOPE

1.1 This method is intended for determining the colorfastness of textile materials when subjected to accelerated weathering conditions.

2. TEST SPECIMENS

2.1 Standard sample. Unless otherwise specified in the procurement document, when a standard sample has been established and the length of time of exposure has been specified, one specimen from each sample unit of the material to be tested and one specimen from the standard sample shall be as specified in 2.2.1 through 2.2.3.

2.1.1 When a standard sample has been established and the length of time of exposure has not been specified, three specimens from each sample unit and three specimens from the standard sample shall be taken for testing. The three specimens shall be cut from adjacent material in the sample unit.

2.2 The specimens for testing shall be as follows:

2.2.1 Cloth. The specimen shall measure 2-1/2 inches by 10 inches (64 mm by 254 mm) with the long dimension parallel to either the warp or filling.

2.2.2 Yarn, thread, light cordage. The specimen shall be of sufficient length so that it may be close-wound on a plastic or wood panel to form a rectangle 2-1/2 inches by 10 inches (64 mm by 254 mm).

2.2.3 Narrow fabrics (tape, webbing, braid). The specimen shall be of sufficient length so that it may be close-wound on a plastic or wood panel to form a rectangle 2-1/2 inches by 10 inches (64 mm by 254 mm) except when the width of the sample unit is greater than 2-1/2 inches (64 mm). When the width of the sample unit is greater than 2-1/2 inches (64 mm) the specimen will be cut so that the longest dimension will be parallel to the length of the sample unit and equidistant from the sides of the sample unit.

2.3 No standard sample. Unless otherwise specified in the procurement document, when a standard sample has not been established, one specimen from the sample unit of the material to be tested shall be as specified in 2.2.1 through 2.2.3. One additional specimen shall be taken from the sample unit of the material to be tested and shall be retained unexposed for comparison. Both specimens shall be cut from adjacent areas of the sample unit.

FED. TEST METHOD STD. NO. 191A

METHOD 5671

3. NUMBER OF DETERMINATIONS

3.1 Unless otherwise specified in the procurement document, one determination shall be made from each sample unit.

4. APPARATUS AND METHODS CITED

4.1 Apparatus.

4.1.1 The apparatus shall be as described for Method 5804.

4.2 Methods cited.

Method 5804, Weathering Resistance of Cloth; Accelerated Weathering Method.
Method 9010, Shade Matching of Textile Materials; Visual Method.

5. PROCEDURE

5.1 All temperatures, water pressures and other conditions required for testing colorfastness to weathering shall be as described in Method 5804.

5.2 Standard sample. When a standard sample has been established and the number of hours of exposure is specified, one holder containing a specimen of the material being tested, and one holder containing a specimen of the standard sample shall be prepared.

5.3 No standard sample. When a standard sample has not been established, one holder containing one specimen of the material to be tested shall be prepared, and the remaining specimens shall be retained unexposed, for comparison purposes.

5.4 When several specimens of the same material are being exposed at the same time and under the same conditions, one specimen of the standard sample shall suffice for comparison with all specimens (see 5.2). When two specimens of the standard sample are to be used, they will suffice for comparison with all specimens of the same material being tested.

5.5 When all specimens are placed in the test chamber and there are unfilled spaces, they shall be filled with specimen holders containing either filler material or other test specimens.

5.6 Length of exposure.

5.6.1 No standard sample. Unless otherwise specified in the procurement document, when a standard sample has not been established, the test specimen shall be exposed for 40 hours.

5.6.2 Standard sample. When a standard sample has been established and the number of hours of exposure is specified, the test specimen and the specimen from the standard sample shall be exposed for the specified number of hours of exposure.

FED. TEST METHOD STD. NO. 191A

METHOD 5671

5.6.2.1 When a standard sample has been established and the number of hours of exposure is not specified, two test specimens from the material undergoing test and two specimens from the standard sample shall be exposed. At the end of 20 hours of exposure, the specimens shall be removed from the test chamber and the test specimens and specimens of this standard sample compared with the unexposed specimens for an "appreciable change in color" as described in 5.7.2.3.

5.6.2.1.1 All the specimens shall be replaced in the machine. This procedure shall be repeated every 20 hours of exposure.

5.6.2.1.2 When an "appreciable change in color" is evident in either test specimen when compared with a specimen of the standard sample, the length of time of exposure shall be recorded and the two specimens (one test specimen showing the "appreciable change in color" and the one specimen of the standard sample) shall be placed in the dark at room temperature for a minimum of 4 hours before evaluation.

5.6.2.1.3 The remaining test specimen and specimen of the standard sample shall again be placed in the test chamber and the exposure continued for an additional number of hours of exposure equal to the number of hours at which the "appreciable change in color" was apparent and the test terminated at the end of that period.

5.6.2.1.4 Specimens which do not show an "appreciable change in color" until 80 hours or more of exposure shall be returned to the test chamber for a total exposure period not exceeding 140 hours of exposure, at which time the test shall be terminated.

5.6.3 At the end of a period of exposure, when the specimens are removed from the test chamber, the specimens will be dried by any convenient method at a temperature not exceeding $176^{\circ} \pm 4^{\circ}\text{F}$ ($80^{\circ} \pm 2^{\circ}\text{C}$) and placed in the dark for a minimum of 4 hours before evaluation.

5.7 Evaluation.

5.7.1 The evaluation tests shall be made only on that part of the specimen which was fully exposed and not protected by the frame or damaged when secured to the rack.

5.7.2 The evaluation of the test specimen with the standard or comparison sample shall be in conformance with Method 9010.

5.7.2.1 Standard sample. When a standard sample has been established and the number of hours of exposure has been established, the test specimen and the specimen of the standard sample shall be compared and the test specimen rated as follows:

- Pass: Color change equal to or less than that of the standard sample.
- Fail: Color change greater than that of the standard sample.

METHOD 5671

5.7.2.2 When a standard sample has been established and the number of hours of exposure has not been established, the test specimen and the specimen of the standard sample which have been exposed for the total exposure shall be compared and the test specimen rated as follows:

- Pass: Color change equal to or less than that of the standard sample.
- Fail: Color change greater than that of the standard sample.

In the event that the standard sample and the test specimen reverse their relative rating from the first appreciable change in color to the end of the exposure cycle, the results at the end of the total exposure cycle shall nevertheless constitute the basis for the rating.

5.7.2.3 No standard sample. When a standard sample has not been established, the exposed test specimen shall be compared with the unexposed specimen from the sample unit and rated as follows:

- Excellent: No perceptible change in color.
- Good: Perceptible, but not appreciable change in color.
- Fair: Appreciable, but not objectionable change in color.
- Poor: Objectionable change in color.

"Appreciable change in color" means a change that is immediately noticeable in comparing the tested specimen with the original specimen for comparison. If closer inspection or a change of angle of light is required to make apparent a slight change in color, the change is not considered appreciable.

6. REPORT

6.1 Standard sample. When a standard sample has been established, colorfastness to weather shall be reported as "pass" or "fail". When failure is reported, the severest departure (i.e. the actual rating, "fair" or "poor"), of the change of the test specimen, shall be distinguished and reported. When specimens are tested as in 5.6.2.1 and evaluated as in 5.7.2.2 they shall be reported as one determination.

6.2 No standard sample. When a standard sample has not been established, colorfastness to weather shall be reported as "pass" or "fail". When failure is reported, the severest departure (i.e. the actual rating, "fair" or "poor"), of the change of the test specimen, shall be distinguished and reported.

6.3 The lot number of the National Bureau of Standard Paper for determination of the Standard Fading Hours shall be reported.

7. NOTES

7.1 Standard light-sensitive paper and booklet of standard fading strips are prepared by and available from the National Bureau of Standards, Washington, Dc 20234. Precautions must be taken to assure that the light-sensitive paper and the book of fading standards are from the same lot of paper, as some variation does occur from one lot of paper to another. The book of Standard Fading Strips and the paper are appropriately marked with the lot number.

To obtain the specific number of Standard Fading Hours during each 20-hour exposure period, a factor may have to be developed to convert clock hours to Standard Fading Hours which will be different for each machine. This is accomplished by establishing the ratio of clock hours to fading hours in the evaluation of the calibration paper. As an example, if the paper exposed for 20 clock hours faded to a degree such that it was interpolated to be 18 Standard Fading Hours, the factor used to arrive at the specified number of Standard Fading Hours would be 0.9. This figure is arrived at by a ratio of $\frac{18}{20} = 0.9$

Example: Assuming that a period of 100 Standard Fading Hours is specified in the procurement document, using the factor, the clock hours of running time would be arrived at as follows:

$$\text{Clock hours required} = \frac{\text{Specified fading hours}}{\text{Factor}} = \frac{100}{0.9} = 111$$

7.2 A 20 Standard Fading Hour exposure in the machine as calibrated by the NBS blue papers should produce a 1.5 NBS units or 4.5 McAdams units of color difference in the A.A.T.C.C. blue wool light-fastness Standard L-4.

7.3 As an alternative, photometric measurements may be used to evaluate the fading of the light-sensitive paper and Standard Exposure Paper.

7.4 An apparatus of the type described in this method may be obtained from the Atlas Electric Devices Co, 4114 North Ravenswood Avenue, Chicago, IL 61613.

7.5 The total exposure time in terms of standard fading hours can also be established by the use of the standard 1/8 inch (3 mm) yellow methacrylate plates dyed with Solvent Yellow #33, C.I. 47000 available from the National Bureau of Standards. The degree of change measured at 420 nm by transmission on a spectrophotometer or on a filter calorimeter equipped with a narrow band pass filter can be converted to standard fading hours by reference to the calibration curve furnished by the NBS. The plate is permitted to stay in the equipment during a full exposure period and measurements made at the end of the exposure cycle or at any intermediate point at the discretion of the individual performing the test. CAUTION: The yellow plates are only useful on carbon arc fading equipment. They are not suitable for outdoor exposure use or in equipments with other types of light sources.

METHOD 5671

7.6 With wool and wool-like materials in particular, the finish of the unexposed area may be altered during the exposure period due to pressure of the holding plates in the specimen holders on the fabric. Also, there is the possibility of changes due to thermal effects. When such situations are noted, two courses of action are possible. One is to evaluate the exposed area against a retained but sponged portion of the fabric. The other is to responge the exposed specimen and evaluate after the specimen has dried and has been conditioned. Where calorimetric methods of measurement are used in evaluation, the exposed specimen shall, in every case, be compared to the retained sponged original specimen.

7.7 For colorfastness evaluation, the apparatus shall never be operated without the filter inclosing the arc.

METHOD 5672
July 20, 1978

COLORFASTNESS TO WEATHER OF TEXTILE MATERIALS;

NATURAL WEATHERING METHOD

1. SCOPE

1.1 This method is intended for determining the colorfastness of textile materials to natural weathering.

2. TEST SPECIMEN

2.1 Standard sample. Unless otherwise specified in the procurement document, when a standard sample has been established, one specimen from the sample unit of the material to be tested and one specimen from the standard sample shall be as follows:

2.1.1 Cloth. A rectangle of cloth measuring at least 2-1/2 inches by 3 inches (64 mm by 76 mm) with the long dimension parallel to the warp direction.

2.1.2 Textile fibers. Fibers made into pads forming a rectangle measuring 2-1/2 inches by 3 inches (64 mm by 76 mm).

2.1.3 Yarn, thread, light cordage, tape, webbing, and braid. Yarn, thread, light cordage, tape, webbing, and braid shall be wound on cards forming a rectangle 2-1/2 inches by 3 inches (64 mm by 76 mm) with the long dimension lengthwise of the material being tested.

2.2 No standard sample. Unless otherwise specified in the procurement document, when a standard sample has not been established, two specimens from the sample unit of the material to be tested shall be as specified in 2.1.1, 2.1.2 or 2.1.3. Both specimens shall be cut from adjacent material in the sample unit and one untested specimen shall be retained for comparison purposes.

3. NUMBER OF DETERMINATIONS

3.1 Unless otherwise specified in the procurement document, one specimen shall be tested from each sample unit.

4. APPARATUS AND METHODS CITED

4.1 Apparatus.

4.1.1 Specimen rack. The rack shall be a wooden frame open at the back to allow free access of air to the specimen and providing means of fastening the top and bottom edges of the specimens to it. The fasteners used must not be made of corrodible materials.

FED. TEST METHOD STD. NO. 191A

METHOD 5672

4.1.2 Exposure area. A place unprotected from the sun and in the town and state specified in the procurement document. Unless otherwise specified in the procurement document, the cloth shall be exposed in a nonindustrial area.

4.1.3 Eppley Pyranometer or equivalent device. A detector used in the measurement of the radiant energy of the sun at the exposure area. The Eppley Pyranometer is a differential thermopile with the hot - junction blackened and the cold - junction whitened, it measures the radiation for a complete hemisphere of the sky. The thermopile is covered by a precision ground, optical glass envelope which is usefully transparent from about 280 to 2800 nm and is replaceable. The EMF generated by the thermopile is recorded by a suitably integrated potentiometer (see 7.1).

4.1.4 Means of recording the prevailing weather conditions.

4.2 Method cited.

Method 9010, Shade Matching of Textile Materials; Visual Method.

5. PROCEDURE

5.1 Standard sample. When a standard sample has been established, a specimen of the standard sample shall be exposed at the same time and under the same conditions as the specimen being tested.

5.2 No standard sample. When a standard sample has not been established, one specimen from each sample unit to be tested shall be exposed and the remaining specimen retained untested for comparison.

5.3 Unless otherwise specified in the procurement document, the specimen shall be exposed in a nonindustrial area.

5.4 Unless otherwise specified in the procurement document, the specimen shall be placed on the rack for a period sufficient to provide a quantum of radiant energy equal to 7,500 langleys (315 MJ/m^2). The specimen shall remain in the specimen rack for 24 hours a day and not be removed until the test is completed. When the colorfastness of the standard sample is known in terms of the number of Standard Fading Hours to produce an appreciable change in colors the exposure under this method shall be 120 langleys (5 MJ/m^2) for each Standard Fading Hour. For example for 40 Standard Fading Hours, the exposure should be 4,800 langleys (200 MJ/m^2).

5.5 This specimen shall be exposed on the rack facing due south (or north if exposed in the Southern Hemisphere) at an angle of 45° from the horizontal.

METHOD 5672

5.6 The specimen shall be exposed for the required period or for a time sufficient to provide a quantum of radiant energy equal to the required number of langley's MJ/m^2 (see 5.4).

5.7 During the exposure period, the radiant energy shall be measured by means of the Eppley Pyranometer or equivalent instrument and the weather condition recorded. The pyranometer shall be exposed at the same angle and under the same conditions as the specimen.

5.8 At the end of the exposure period, the specimen shall be removed from the rack and allowed to lie in the dark at room temperature for a minimum of 4 hours before evaluation.

5.9 Evaluation. The evaluation of the test specimen with the standard or comparison sample shall be in conformance with Method 9010.

5.9.1 Standard sample. When a standard sample has been established and utilized in the test, the test specimen shall be compared with the standard sample and rated as follows:

Pass: Color change equal to or less than that of the standard sample.
Fail: Color change greater than that of the standard sample.

5.9.2 No standard sample. When a standard sample has not been established, unless otherwise specified in the procurement document, the test specimen shall be compared to the unexposed specimen and rated as follows:

Excellent: No perceptible change in color.
Good: Perceptible, but not appreciable change in color.
Fair: Appreciable, but not objectionable change in color.
Poor: Objectionable change in color.

"Appreciable change in color" means a change that is immediately noticeable in comparing the tested specimen with the original sample for comparison. If closer inspection or a change in angle of light is required to make apparent a slight change in color, the change is not considered appreciable.

6. REPORT

6.1 The location of the exposure, town and state, and whether or not the area is nonindustrial shall be reported.

6.2 The total radiation in langley's (MJ/m^2) to which the specimen was exposed shall be reported.

METHOD 5672

6.3 Standard sample. When a standard sample has been established, colorfastness to weathering shall be reported as "pass" or "fail". When failure is reported, the severest departure (i.e. the actual rating, "fair" or "poor"), of the change of the test specimen, shall be distinguished and reported.

6.4 No standard sample. When a standard sample has not been established, colorfastness to weathering shall be reported as "pass" or "fail". When failure is reported, the severest departure (i.e. the actual ratings "fair" or "poor"), of the change of the test specimen, shall be distinguished and reported.

7. NOTES

7.1 A machine of the type described may be purchased from the Eppley Laboratory Inc., Newport, RI 20840.

METHOD 5675
July 20, 1978

COLORFASTNESS OF CLOTH TO OXIDES OF NITROGEN IN
THE ATMOSPHERE

1. SCOPE

1.1 This method is intended for determining the resistance to color change of dyed textile cloths when exposed to oxides of nitrogen in the atmosphere.

2. TEST SPECIMEN

2.1 Standard sample. Unless otherwise specified in the procurement document, when a standard sample has been established, the required specimens from the sample unit of the material to be tested and one specimen from the standard sample shall be as follows:

2.1.1 Cloth. The specimen shall be a rectangle of cloth 2 by 5 inches (51 mm by 127 mm), and shall be cut from a wrinkle free portion of the sample unit.

2.2 No standard sample. Unless otherwise specified in the procurement document, when a standard sample has not been established, the required specimens from the sample unit of the material to be tested shall be as specified in 2.1.1. One additional specimen shall be taken from each sample unit of the material to be tested and shall be retained, untested, for comparison. All specimens shall be taken from adjacent areas in the sample unit.

3. NUMBER OF DETERMINATIONS

3.1 Unless otherwise specified in the procurement document, one specimen shall be tested from each sample unit.

4. APPARATUS AND METHOD CITED

4.1 Gas Fading Test Chamber. A Gas Fading Test Chamber or similar equipment in which test specimens can be exposed to air which has passed through the flame of a lighted gas burner (see 7.1). In order to assure uniform fading of the specimens, the arms on which they are hung shall be revolved at a rate of 2 RPM.

4.2 Gas Fading Control Sample No. 1 (see 7.2).

4.3 Standard of Fading (See 7.2).

4.4 Gray Scale for Color Change (see 7.3).

FED. TEST METHOD STD. NO. 191A

METHOD 5675

4.5 Method cited.

Method 9010, Shade Matching of Textile Materials; Visual Method.

5. PROCEDURE

5.1 The specimens shall be folded one inch (25 mm) from the top and an office stapling device used to form a loop. The loop permits the specimen to be placed on the specimen rack so that the flat surface of the cloth moves in direct contact with gases.

5.2 The test specimens shall be suspended in the Gas Fading Test Chamber together with a specimen of Control Sample No. 1 (see 7.2). The specimens shall be mounted no nearer the outside edge of the specimen rack than 1-1/4 inches (32 mm) and no nearer the hub of the specimen rack than 1-1/2 inches (38 mm). The test specimens shall not be brought into direct contact with hot metallic surfaces.

5.3 The gas burner shall be ignited and the flame adjusted so that the temperature in the chamber does not exceed 140°F (60°C).

5.4 The specimens (test and control) shall remain in the chamber until Control Sample No. 1 shows a change of shade corresponding with that of the Standard of Fading (see 7.2). The test specimens shall then be removed from the chamber and immediately compared to the specimen retained untested, for comparison. This constitutes one exposure cycle.

5.5 Test specimens which show no fading shall be suspended again in the chamber along with a fresh Control Sample, and the test shall be continued until the Control Sample shows a change of shade corresponding with that of the Standard of Fading. The procedure shall be repeated as often as necessary to produce an appreciable alteration of shade in the test specimens.

5.6 Evaluation.

5.6.1 Evaluation shall be conducted in accordance with Method 9010.

5.6.2 The resistance to color change of the test specimens shall be evaluated after each exposure period.

5.6.3 Standard sample. When a standard sample has been established, the test specimen will be compared to the specimen from the standard sample and rated as follows:

Specimen. Pass: Color change equal to or less than that of the standard sample.
Fail: Color change greater than that of the standard sample.

5.6.4 No standard sample. When a standard sample has not been established, the test specimen will be compared to the specimen retained untested for comparison to determine the number of exposure periods required to produce an appreciable change in color in the test specimens. An "appreciable change in color" means a change that is immediately noticeable in comparing the test specimen with the original sample as comparison. If closer inspection or a change of angle of light is required to make apparent a slight change in color, the change is not considered appreciable.

5.6.4.1 The effect on the color of the test specimens after the required number of cycles shall be expressed by reference to the Gray Scale for Color Change as follows:

- Class 5 - Negligible or no change as shown in Gray Scale Step 5.
- Class 4 - A change in color equivalent to Gray Scale Step 4.
- Class 3 - A change in color equivalent to Gray Scale Step 3.
- Class 2 - A change in color equivalent to Gray Scale Step 2.
- Class 1 - A change in color equivalent to Gray Scale Step 1.

6. REPORT

6.1 Standard sample. When a standard sample has been established, the resistance to color change of textile cloths when exposed to oxides of nitrogen in the atmosphere shall be reported as "pass" or "fail". When failure is reported, the severest departure (i.e. the actual rating, "fair" or "poor"), of the change of the test specimen, shall be distinguished and reported.

6.2 No standard sample. The resistance to color change of textile cloths exposed to oxides of nitrogen in the atmosphere shall be reported as "pass" or "fail" when the test specimen is evaluated and rated in accordance with the adjective ratings specified in 5.6.4.1. Failure of the test specimen to meet the adjective rating specified in the applicable procurement document shall be reported as failure. When failure is reported, the actual Gray Scale classification of the color change of the test specimen shall also be distinguished and reported.

7. NOTES

7.1 The Gas Fading Test Chamber may be obtained from the US Testing Co., 1415 Park Avenue, Hoboken, NJ 07030.

METHOD 5675

7.2 Gas Fading Control Sample No. 1 is sensitive to atmospheric gases and shall be kept in a closed container and protected from strong light when not in use. A sealed unit of Control Sample No. 1, comprising 20 yards (183 m) of ribbon 2-1/4 inches (57 mm) wide, and a specimen of the standard of Fading may be obtained from TestFabrics, Inc., P.O. Box 53, 200 Blackford Ave., Middlesex, NJ 08846.

7.3 Gray Scale for Color Change may be obtained from the American Association of Textile Chemists and Colorists, P.O. Box 12215, Research Triangle Park, NC 27709.

COLORFASTNESS OF TEXTILE MATERIALS TO PERSPIRATION;

PERSPIROMETER METHOD

1. SCOPE

1.1 This method is intended for determining the colorfastness of textile materials to perspiration. It is applicable to dyed, printed or otherwise colored textiles of all kinds.

2. TEST SPECIMEN

2.1 Standard sample. Unless otherwise specified in the procurement document, when a standard sample has been established, the required specimens from each sample unit of the material to be tested and two specimens from the standard sample shall be as follows:

2.1.1 Cloth. A square of cloth 2-1/2 inches (64 mm).

2.1.2 Fibers, yarn, thread, light cordage, tape, webbing, and braid. Sufficient lengths of the applicable specimen shall be arranged to form a square 2-1/2 by 2-1/2 inches (64 mm by 64 mm).

2.2 No standard sample. Unless otherwise specified in the procurement document, when a standard sample has not been established, the required specimens from the sample unit of the material to be tested shall be as specified in 2.1.1 and 2.1.2. One additional specimen shall be taken from each sample unit of material to be tested and retained, untested, for comparison. All specimens shall be taken from adjacent areas of the sample unit.

3. NUMBER OF DETERMINATIONS

3.1 Unless otherwise specified in the procurement document, one specimen from each sample unit shall be tested in each of the two perspiration solutions.

4. APPARATUS, REAGENTS AND METHOD CITED

4.1 Apparatus.4.1.1 Perspirometer or equivalent apparatus.

4.1.1.1 The Perspirometer is a testing device capable of maintaining uniform pressure on the test specimen located between two glass plates (3 inches by 2-1/2 inches by 1/4 inch) (76 mm by 64 mm by 6 mm).

METHOD 5680

4.1.1.2 Two Perspirometer models are permissible.

4.1.1.2.1 The pressure is obtained in one model by added weights, with plates being stacked vertically, until the pressure is adjusted. When the required pressure is reached, the pressure plate is locked, the weights removed, and the unit placed in the oven so that the plates and specimens are vertical.

4.1.1.2.2 The pressure in the second model is obtained by means of adjusting screws, the moveable plate being made to exert increasing pressure against the test specimens until the required force is reached as indicated on the scale. The specimen unit is locked at this point, removed from the section applying the pressure, and placed in the oven so that the plates and specimens are vertical.

4.1.2 Wringer. A wringer of the household type equipped with smooth rubber rolls 2-1/8 to 2-1/2 inches (54 mm to 64 mm) in diameter and not less than 11 inches (279 mm) or more than 16 inches (406 mm) in length. The rubber rolls shall have a Shore Durometer Hardness of 70 to 80 (A scale). The load exerted on the specimen shall be applied uniformly by means of an adjustable weight attached to the top roll. The total load of the roll, means of attaching the weight, and the weight itself shall be such that the specimen will retain 100 percent moisture. The rolls shall be power driven at such a speed that the specimen shall pass between the rolls at the rate of 1 inch (25 mm) per second.

4.1.3 Oven. A circulating air oven capable of maintaining the required temperature at $\pm 2^{\circ}\text{F}$ ($\pm 1^{\circ}\text{C}$).

4.1.4 Color transfer cloth. A test cloth with a 6-fiber repeat made up of equal bars of acetate, cotton, nylon 66, polyester (polyethylene terephthalate) acrylic and wool. Each 6-fiber repeat shall measure approximately 2 inches (51 mm) and shall be separated by a waste filling stripe (see 7.2).

4.1.5 White thread.4.2 Reagents.

4.2.1 Acid solution. - 10 g sodium chloride
1 g lactic acid U.S.P., 85 percent
0.25 g histidine monohydrochloride.
1 g disodium orthophosphate, anhydrous.

Dissolve with distilled water and make up to 1 liter. This solution shall have a pH of 3.5. If the pH is not 3.5, suitable adjustments shall be made with lactic acid and disodium orthophosphate or monosodium orthophosphate, or a new solution is prepared.

METHOD 5680

- 4.2.2 Alkaline solution - 10 g sodium chloride.
4 g ammonium carbonate U.S.P.
0.25 g histidine monohydrochloride.
1 g disodium orthophosphate, anhydrous.

Dissolve in distilled water and make up to 1 L. This solution shall have a pH of 8.0. If the pH is not 8.0, suitable adjustments shall be made with disodium orthophosphate, monosodium orthophosphate, or ammonium carbonate or a new solution may be prepared.

4.3 Method cited.

Method 9010, Shade Matching of Textile Materials; Visual Method.

5. PROCEDURE

5.1 Preparation of specimen.

5.1.1 One 6-fiber repeat of the color transfer cloth shall be sewn with white thread or otherwise firmly attached to each specimen of the material to be tested and to each specimen of the standard sample.

5.2 The testing of 2 specimens (i.e., one in the acid solution and one in the alkaline solution) shall be considered one determination.

5.2.1 Standard sample. When a standard sample has been established, two specimens of the standard sample shall be tested at the same time and under the same conditions as the specimens undergoing test.

5.2.2 No standard sample. When a standard sample has not been established the required specimens of the material undergoing test shall be tested, and one specimen shall be retained without testing for comparison.

5.3 One test assembly (see 5.2) shall be immersed in the acid solution for 30 minutes with occasional stirring. The other test assembly shall be immersed in the alkaline solution for 30 minutes with occasional stirring. Care shall be exercised to insure that the assemblies are adequately wetted by the solutions.

5.3.1 To insure that the test assembly treated with the acid solution has a pH of 3.5 and that the assembly treated with the alkaline solution has a pH of 8.0, the assemblies shall be rinsed 3 times with the appropriate test solution, the rinse solution being discarded each time.

5.4 The test assemblies, when removed from the solutions, shall be passed flat through the wringer to remove excess liquid, retaining the equivalent of 100 percent pickup by the assembly.

METHOD 5680

5.4.1 Each of the test assemblies shall be placed between glass plates and inserted in the Perspirometer. The Perspirometer shall be adjusted to produce a pressure of 10 pounds (70 kPa) on the test assemblies.

5.4.2 The loaded test plate units shall be placed in the oven for a minimum of 6 hours, the temperature of the oven maintained at $100^{\circ} \pm 2^{\circ}\text{F}$ ($38^{\circ} \pm 1^{\circ}\text{C}$). For convenience, the test may be run overnight for as much as 16 hours. Tests have shown that no appreciable or additional change in shade or staining occurs after the 6-hour period.

5.4.3 The test assemblies shall be removed from the test plates. If the assemblies are not completely dry at this time, they may be dried by any convenient means at a temperature not to exceed 150°F (82°C).

5.5 Evaluation.

5.5.1 Evaluation shall be conducted in accordance with Method 9010.

5.5.2 The color change of the test specimen and the staining of the color transfer cloth shall be evaluated to determine the colorfastness to perspiration.

5.5.3 The color change exhibited by the tested specimen when compared to the untested specimen retained shall be evaluated against the color change exhibited by the tested standard when compared to the untested standard retained. Unless otherwise specified, the staining of the color transfer of the specimen shall be evaluated against the staining of the color transfer cloth of the standard.

5.5.3.1 Specimen

Pass: Color change less than that of the standard sample.

Fail: Color change greater than that of the standard sample.

5.5.3.2 Color transfer cloth.

Pass: Staining equal to or less than that attached to the standard sample.

Fail: Staining greater than that attached to the standard sample.

5.5.4 No standard sample. When a standard sample has not been established, evaluation of the test specimen and its attached color transfer cloth shall be rated as follows:

5.5.4.1 Test specimen when compared to the specimen retained untested for comparison and color transfer cloth evaluated according to the degree of staining shall be rated as:

METHOD 5680

Excellent: No perceptible color change and staining.

Good: Perceptible but not an appreciable change in color and staining.

Fair: Appreciable but not an objectionable change in color and staining.

Poor: Objectionable change in color and staining.

"Appreciable change in color" means change that is immediately noticeable in comparing the tested specimen with the original sample for comparison. If closer inspection or a change of angle of light is required to make apparent a slight change of color, the change is not considered appreciable."

6. REPORT

6.1 Standard sample. Colorfastness to perspiration shall be reported as "pass" or "fail" when compared with the standard sample. If either the test specimen or the transfer cloth of the test specimen shows failure when compared to comparable material of the standard sample, the specimen shall be reported as failing. When failure is reported the nature of the failure shall also be reported.

6.2 No standard sample. Colorfastness to perspiration shall be reported as "pass" or "fail" when the test specimen and color transfer cloth are evaluated and rated in accordance with the adjective ratings of 5.5.4. Failure of either the test specimen or the color transfer cloth to meet the adjective rating specified in the applicable procurement document shall be reported as failing. When failure is reported, the severest departure (i.e. the actual rating, "fair" or "poor"), of the change of test specimen or staining of specific fibers of the color transfer cloth, shall be distinguished and reported.

7. NOTES

7.1 Equipment suitable for conducting this test may be purchased from: The Orange Machine and Manufacturing Company, 1503 Bay Avenue, Point Pleasant, NJ 08742 and Atlas Electric Devices Company, 4114 No. Ravenswood Avenue, Chicago, IL 60613.

7.2 Multifiber test cloths (color transfer cloth) may be obtained from Test Fabrics, Inc., P.O. Box 53, 200 Blackford Ave., Middlesex, NJ 08846.

MILDEW RESISTANCE OF TEXTILE MATERIALS; SINGLE CULTURE METHOD

1. SCOPE

1.1 This method is intended for determining the mildew resistance of textile materials.

2. TEST SPECIMEN

2.1 Qualitative.

2.1.1 Cloth. For visual examination, the specimen shall be a square of cloth 2 inches by 2 inches (51 mm by 51 mm).

2.1.2 Yarn, thread, cordage, tape. For visual examination, the specimen shall be of approximate size for placing in a 100 mm petri dish. Heavy cordage specimens, representative of the sample unit to be tested, shall be ravelled to give a set of yarns 6 inches (152 mm) long, tied together, which can be conveniently placed in a petri dish.

2.2 Quantitative.

2.2.1 Cloth. Unless otherwise specified in the procurement document, the cloth specimen shall be described in Method 5104, except that it shall be approximately 6 inches (152 mm) long with the long direction parallel to the warp.

2.2.2 Yarn and thread. Unless otherwise specified in the procurement document, yarn and thread specimens shall be as described in Method 4100.

2.2.3 Cordage. Unless otherwise specified in the procurement document, cordage specimens shall be prepared as in Method 6016, except for twisted cordage samples of 1/2 inch (13 mm) diameter or larger, when the specimen shall be ravelled to a diameter and cut to a length appropriate for inoculation and testing for change in breaking strength as described in Method 6016.

2.3 Number of specimens.

2.3.1 Qualitative testing. Unless otherwise specified in the procurement document, five specimens shall be taken for qualitative testing.

METHOD 5750

2.3.2 Quantitative testing. Unless otherwise specified in the procurement document, 40 specimens shall be taken from the sample unit for quantitative testing. Twenty specimens shall be retained, unexposed and subjected to the same physical tests as the exposed specimens with the intention of establishing the average tensile strength for the purpose of computing the percent loss of the exposed strips.

2.4 Viability control. Untreated material, similar in all other respects to the treated material under test, shall be inoculated and incubated with the test material to verify the viability of the test organism. When untreated material is not available, material known to support the growth of the particular organisms, as filter paper Whatman No. 2, shall be used. If this untreated material fails to show an abundant growth of the test organisms, the test shall be considered inconclusive and shall be repeated.

3. NUMBER OF DETERMINATIONS

3.1 Qualitative. Unless otherwise specified in the procurement document, five specimens shall be tested from each sample unit for the "growth" determination.

3.2 Quantitative. Unless otherwise specified in the procurement document, 20 specimens shall be tested from each sample unit for change in characteristic.

4. APPARATUS AND METHODS CITED

4.1 Apparatus.

4.1.1 Autoclave. Autoclave capable of being operated at a steam pressure of 15 pounds per square inch (103 kPa), and an exhaust temperature of 250°F (121°C) for sterilization of the laboratory prepared culture media as described in 4.1.4.

4.1.2 Glassware.

4.1.2.1 Culture flask. Erlenmeyer flasks for sterilizing and storing culture media.

4.1.2.2 Culture dishes. Petri dishes which will permit intimate contact between the substrate and the specimen.

4.1.2.3 16 ounce (0.5 L) bottles. Square bottom bottles with modified screw caps for use in the quantitative test. The caps shall be prepared by cutting a circle 10 to 20 mm in diameter from the center of the cap. A round

FED. TEST METHOD STD. NO. 191A

METHOD 5750

piece of glass filter cloth (Owens-Corning "Fiberglass" C.S. 30-A-20 or the equivalent) equal in size to the inside of the cap shall be inserted in the cap. A retaining ring of rubber or other material shall be placed over the cloth. The 16 ounce (0.5 L) bottles may be replaced by the 150 mm petri dishes in the quantitative testing of yarn, thread, and cordage.

4.1.3 Incubator. Incubator room or cabinet maintained at a temperature of 82° to 86°F (28° to 30°C), and a relative humidity of 85 to 95 percent.

4.1.4 Culture media. Culture media shall have the following composition:

Potassium dihydrogen phosphate	1.00 g
Ammonium nitrate	3.00 g
Magnesium sulfate heptahydrate	0.25 g
Agar	20.00 g
Distilled water	1000.00 ml

4.1.5 Organism. *Chaetomium globosum* ATCC 6205, QM459.

4.1.5.1 The culture medium for growing the *Chaetomium globosum* shall be as described in 4.1.4.

4.2 Stock culture. Stock culture to be used for the preparation of the suspension inoculum shall be grown in sterilized 250 ml Erlenmeyer flasks.

4.2.1 The culture medium is melted in an autoclave or in a boiling water bath, cooled to about 122°F (50°C) and then approximately 50 ml of the medium is poured into a sterile 250 ml Erlenmeyer flask. The flasks with cotton stoppers are left undisturbed until the agar has hardened. A sterile 70 mm disc of Whatman No. 2 filter paper is placed on the hardened surface of the agar and then inoculated by flooding with a thin suspension of *Chaetomium globosum* spores and decanting the excess suspension. The inoculated culture medium is then incubated at 82° to 86°F (28° to 30°C) for 7 days or until covered with fruiting bodies and refrigerated until used. Aseptic technique is required, cultures older than 14 days shall not be used.

4.3 Methods cited:

- Method 4100 - Strength and Elongation, Breaking; and Tenacity; of Thread and Yarn; Single Strand.
- Method 5104 - Strength and Elongation, Breaking of Woven Cloth; Ravel Strip Method.
- Method 5830 - Leaching Resistance of Cloth; Standard Method.
- Method 6016 - Strength and Elongation, Breaking of Cordage; Non-Spliced Specimen Method.

METHOD 5750

5. PROCEDURE

5.1 Resistance to mildew shall be determined qualitatively or quantitatively, as specified in the procurement document.

5.1.1 Quantitative. Unless otherwise specified in the procurement document, resistance to mildew shall be determined by the change in breaking strength using Method 5104 for cloth; Method 4100 for yarn and thread; and Method 6016 for light cordage and the ravened specimens of heavy cordage (rope) (see 2.2.3).

5.2 Unless otherwise specified in the procurement document, the specimens shall be leached before exposure to mildew, as specified in Method 5830.

5.3 Preparation of container. The culture medium in the flask shall be melted in an autoclave or a boiling water bath, cooled to about 122°F (50°C), and then poured into the sterile petri dish or bottle and left undisturbed until the agar has hardened. Approximately 25 ml are required for each petri dish and 50 ml for each 16 ounce (0.5 L) bottle. The bottles are to be cooled lying on their sides. Aseptic precautions are not required.

5.4 Inoculum. The spores of Chaetomium globosum are borne in dark gray to black perithecia (fruiting bodies) and do not readily go into suspension without disruption of the perithecia. This is easily accomplished by scraping the perithecia from the surface of a mature (10-14 day) culture and transferring them to a screw-capped flask or bottle containing about 50 ml of water and an equal volume of 3-6 mm glass beads. Several minutes vigorous shaking will release the spores from the perithecia and the resulting suspension can be decanted for use.

5.5 Inoculation. The specimen shall be dipped in a fresh inoculum suspension and placed in contact with the hardened agar in the culture vessel. Other equally satisfactory methods of inoculation, such as pipetting, may be used.

5.6 Incubation. The inoculated specimen shall be incubated for 14 days at a temperature of 82° to 86°F (28° to 30°C).

5.7 Evaluation.

5.7.1 Qualitative. At the end of the incubation period, the specimen shall be examined for presence of any growth of Chaetomium globosum.

METHOD 5750

5.7.2 Quantitative. At the end of the incubation period, the inoculated specimen shall be removed from the petri dish or bottle and gently rinsed in tap water to remove surface mildew. It shall then be air-dried and conditioned for 24 hours under standard atmospheric conditions in accordance with Section 4 of this Standard. The uninoculated controls shall be similarly rinsed, air dried, and conditioned. At the end of the conditioning period the breaking strength of cloth, yarn, thread, and cordage, if required, shall be determined according to the methods described in paragraph 5.1.1. The breaking strength of cloth shall be determined in the warp direction only, as described in Method 5104. If other physical tests are required, the specimen shall be tested as described in the required method. The same physical tests shall be conducted on exposed and on unexposed specimens for the purpose of comparison in determining the degree of mildew resistance of the infected samples.

5.8 Calculation of results.

5.8.1 Quantitative. The change in breaking strength or other characteristics of the specimen shall be calculated as follows:

$$\text{Change in characteristic, percent} = \frac{O - E}{O} \times 100$$

Where: O = Average value of unexposed specimens.

E = Average value of exposed specimens.

6. REPORT

6.1 Qualitative.

6.1.1 Each specimen tested shall be reported as showing "growth" or "no growth" of *Chaetomium globosum*.

6.2 Quantitative.

6.2.1 The change in breaking strength or other characteristic of the sample unit, after exposure to mildew, shall be the average of the results obtained from the specimens tested and shall be reported as "percent change", to the nearest 1.0 percent.

6.2.2 Each individual value used to calculate the average shall also be reported.

METHOD 5750

7. NOTES

7.1 Pure cultures of the organisms required to this and other methods or tests for mildew resistance may be obtained from one of the following:

- (a) American Type Culture Collection (ATCC)
12301 Parklawn Drive
Rockville, MD 20852
- (b) (QM cultures)
USDA Northern Regional Research Center
ARS Culture Collection
1815 No. University Street
Peoria, IL 61604

FED. TEST METHOD STD. NO. 191A

METHOD 5760
July 20, 1978

MILDEW RESISTANCE OF TEXTILE MATERIALS;

MIXED CULTURE METHOD

1. SCOPE

1.1 This method is intended for determining the mildew resistance of textile materials.

2. TEST SPECIMEN

2.1 Qualitative.

2.1.1 Cloth. For visual examination, the specimen shall be a square of cloth 2 inches by 2 inches (51 by 51 mm).

2.1.2 Yarn, thread, cordage, tape. For visual examination, the specimen shall be of appropriate size for placing in a 100 mm petri dish. Heavy cordage specimens, representative of the sample unit to be tested, shall be ravelled to give a set of yarns 6 inches (152 mm) long, tied together, which can be conveniently placed in a petri dish.

2.2 Quantitative.

2.2.1 Cloth. Unless otherwise specified in the procurement document, the cloth specimen shall be as described in Method 5104, except that it shall be approximately 6 inches (152 mm) long, with the long direction parallel to the warp.

2.2.2 Yarn and thread. Unless otherwise specified in the procurement document, yarn and thread specimens shall be as described in Method 4100.

2.2.3 Cordage. Unless otherwise specified in the procurement document, cordage specimens shall be prepared as in Method 6016, except for twisted cordage samples of 1/2 inch (13 mm) diameter or larger, when the specimen shall be ravelled to a diameter and cut to a length appropriate for inoculation and testing for change in breaking strength as described in Method 6016.

2.3 Number of specimens.

2.3.1 Qualitative testing. Unless otherwise specified in the procurement document, five specimens shall be taken for qualitative testing.

METHOD 5760

2.3.2 Quantitative testing. Unless otherwise specified in the procurement document, 40 specimens shall be taken from the sample unit for quantitative testing. Twenty specimens shall be retained, unexposed and subjected to the same physical tests as the exposed specimens for the purpose of comparison to determine the degree of mildew resistance of the affected specimens.

2.3.3 Viability control. Untreated specimens, similar in all other respects as the treated specimens under test, shall be inoculated and incubated with the test culture to verify the viability of the test organisms. When an untreated test specimen is unavailable, untreated material similar to the test specimen in construction, fiber, and weight may be substituted. If this control specimen fails to show an abundant growth of mildew, the test shall be considered inconclusive and shall be repeated.

3. NUMBER OF DETERMINATIONS

3.1 Qualitative. Unless otherwise specified in the procurement document, five specimens shall be tested from each sample unit for "growth" determination.

3.2 Quantitative. Unless otherwise specified in the procurement document, 20 specimens shall be tested from each sample unit for change in characteristic.

4. APPARATUS AND METHODS CITED

4.1 Apparatus.

4.1.1 Autoclave. Autoclave capable of being operated at a steam pressure of 15 pounds per square inch (103 kPa) and an exhaust temperature of 250°F (121°C) for sterilization of the laboratory prepared culture media as described in 4.1.4.

4.1.2 Glassware.

4.1.2.1 Culture flask. Erlenmeyer flasks for sterilizing and storing culture media.

4.1.2.2 Culture dishes. Petri dishes which will permit intimate contact between the substrate and the specimen.

4.1.2.3 16 ounce (0.5 L) bottles. Square bottom bottles with modified screw caps for use in the quantitative test. The caps shall be prepared by cutting a circle 10 to 20 mm in diameter from the center of the cap. A round piece of glass filter cloth (Owens-Corning 'Fiberglass' C. S. 30-A-20 or equivalent) equal in size to the inside of the cap shall be inserted in the cap. A retaining ring of rubber or other material shall be placed over the cloth. The 16 ounce (0.5 L) bottles may be replaced by the 150 mm petri dishes in the quantitative testing of yarn, thread and cordage.

FED. TEST METHOD STD. NO. 191A

METHOD 5760

4.1.3 Incubator. Incubator room or cabinet maintained at a temperature of 82° to 86°F (28° to 30°C), and a relative humidity of 85 to 95 percent.

4.1.4 Culture media. Culture media shall have the following composition:

Potassium dihydrogen phosphate	1.00 g
Ammonium nitrate	3.00 g
Magnesium sulfate heptahydrate	0.25 g
Agar	20.00 g
Distilled water	1000.00 ml

4.1.4.1 Stock culture medium. All stock cultures shall be maintained on potato dextrose agar slants.

4.1.5 Organisms.

4.1.5.1 Chaetomium globosum. ATCC 6205; QM459.

4.1.5.2 Myrothecium verrucaria. ATCC 9095; QM460.

4.1.5.3 Trichoderma sp. ATCC 9645; QM365.

4.1.5.4 Memnoniella echinata. ATCC 11973; QM1225.

4.1.5.5 Aspergillus niger. ATCC 6275; QM458.

4.1.5.6 Aspergillus clavatus. ATCC 18214; QM862.

4.2 Methods cited.

- Method 4100 - Strength and Elongation, Breaking; and Tenacity; of Thread and Yarn; Single Strand.
- Method 5104 - Strength and Elongation, Breaking of Woven Cloth; Ravel Strip Method.
- Method 5804 - Weathering Resistance of Cloth; Accelerated Weathering Method.
- Method 5830 - Leaching Resistance of Cloth; Standard Method.
- Method 6016 - Strength and Elongation, Breaking of Cordage; Non-Spliced Specimen Method.

5. PROCEDURE

5.1 Resistance to mildew shall be determined qualitatively or quantitatively, as specified in the procurement document.

METHOD 5760

5.1.1 Quantitative. Unless otherwise specified in the procurement document, resistance to mildew shall be determined by the change in breaking strength using Method 5104 for cloth; Method 4100 for yarn and thread; and Method 6016 for light cordage and the ravened specimens of heavy cordage (rope) (see 2.2.3).

5.2 Unless otherwise specified in the procurement document, the specimen shall be subjected to accelerated weathering, Method 5804, followed by leaching Method 5830, before exposure to mildew.

5.3 Stock culture. Stock cultures to be used for the preparation of the spore-suspension inoculum shall be maintained on potato dextrose agar slants (see 4.1.4.1). All cultures not used after 21 days shall be discarded.

5.4 Inoculum. The inoculum shall consist of a mixed spore suspension. Approximately 10 ml of 0.05 percent Sodium lauryl Sulfate (Duponol or other product) or similar nontoxic wetting agent shall be poured into each stock culture tube, the spores dispersed with the aid of an inoculating needle, and the resulting suspensions combined and extended to 200 ml with the wetting agent.

5.4.1 Inoculum. The spores of Chaetomium globosum are borne in dark gray to black perithecia (fruiting bodies) and do not readily go into suspension without disruption of the perithecia. This is easily accomplished by scraping the perithecia from the surface of a mature (10-14 day) culture and transferring them to a screw-capped flask or bottle containing about 50 ml of water and an equal volume of 3-6 m glass beads. Several minutes vigorous shaking will release the spores from the perithecia and the resulting suspension can be decanted for use.

5.5 Inoculation.

5.5.1 The chemical constituents of the test culture medium shall be carefully weighed and completely dissolved in the distilled water, after which the 2 percent agar is added, melted, and 25 ml aliquots of the warm agar medium poured into sterilized petri dishes. When the medium has hardened, the specimens shall be placed on the agar surface.

5.5.2 The specimen shall be placed in the dish or bottle. A ravened strip specimen shall be folded approximately 1-1/2 inches (38 mm) from each end and the central portion placed on the agar surface. Unless otherwise specified in the procurement document, 20 replica specimens shall be inoculated. An equal number shall be retained as uninoculated specimens.

5.5.3 The specimen shall be inoculated by pipetting 2 ml of the mixed spore suspension onto the upper surface of that portion of the specimen lying on the surface of the agar.

FED. TEST METHOD STD. NO. 191A

METHOD 5760

5.6 Incubation. The inoculated specimens shall be incubated at a temperature of 82° to 86°F (28° to 30°C). The duration of the incubation period for cloth shall be as follows: If the material weighs 21 ounces or less per square yard (712 g/m² or less), the specimen shall be incubated for 14 days; if the material weighs more than 21 ounces per square yard (712 g/m² or more), the specimen shall be incubated for 21 days.

5.7 Evaluation.

5.7.1 Qualitative. At the end of the incubation period, the inoculated specimen shall be examined for the presence of any growth of mildew.

5.7.2 Quantitative. At the end of the incubation period, the inoculated specimen shall be removed from the petri dish and gently rinsed in tap water to remove surface mildew. It shall then be air-dried and conditioned for 24 hours under standard atmospheric conditions in accordance with Section 4 of this Standard. The uninoculated controls shall be similarly rinsed, air-dried, and conditioned. At the end of the conditioning period, the breaking strength of cloth, yarn, thread, and cordage, if required, shall be determined according to the methods described in paragraph 5.1.1. The breaking strength of the cloth shall be determined in the warp direction only, as described in Method 5104. If other physical tests are required, the specimen shall be tested as described in the required method. The same physical tests shall be conducted on exposed and on unexposed specimens for the purpose of comparison in determining the degree of mildew resistance of the infected samples.

5.8 Calculation of results.

5.8.1 Quantitative. The change in breaking strength or other characteristic of the specimen shall be calculated as follows:

$$\text{Change in characteristic, percent} = \frac{O - E}{O} \times 100$$

Where: O = Average value of unexposed specimens.

E = Average value of exposed specimens.

6. REPORT

6.1 Qualitative.

6.1.1 Each specimen tested shall be reported as showing "growth" or "no growth" of mildew.

MBTHOD 5760

6.2 Quantitative.

6.2.1 The change in breaking strength or other characteristic of the sample unit after exposure to mildew shall be the average of the results obtained from the specimens tested and shall be reported as percent change, to the nearest 1.0 percent.

6.2.2 Each individual value used to calculate the average shall also be reported.

7. NOTES

7.1 Pure cultures of the organisms required in this and other methods or test for mildew resistance may be obtained upon request from one of the following:

(a) American Type Culture Collection (ATCC)
12301 Parklawn Drive
Rockville, MD 20852

(b) (QM cultures)
USDA Northern Regional Research Center
ARS Culture Collection
1815 No. University Street
Peoria, IL 61604

FED. TEST METHOD STD. NO. 191A

METHOD 5762
July 20, 1978

MILDEW RESISTANCE OF TEXTILE MATERIALS; SOIL BURIAL METHOD

1. SCOPE

1.1 This method is considered to be the most severe microbiological test procedure available. It is intended for use with textile materials which require high resistance to fungus attack or may be subjected to severe molding conditions such as prolonged contact with the ground during use of long exposure in severe climate. It may also be used as a test in evaluating new fungicides, especially when a known fungicide of established efficiency is used as a reference standard.

2* TEST SPECIMEN

2.1 Unless otherwise specified in the procurement document the test specimen shall be as follows.

2.1.1 Cloth. The cloth specimen shall be as specified in Method 5104 except that the long dimension shall be parallel with the warp.

2.1.2 Thread and yarn. The specimen shall be specified in Method 4100.

2.1.3 Webbing. The specimen shall be as specified in Method 6016.

2.1.4 Cordage. The specimen shall be as specified In Method 6016 except that for cordage of 1/2 inch (13 mm) diameter or larger shall be as specified in Method 6015 except that the length between the inner ends of the splices shall be 3 to 5 feet (1 to 1.5 m).

2.2 Viability control. Untreated material similar in all other respects to the treated material except that when a cloth specimen is to be tested, the control specimens shall be untreated cloth of about 12 to 14 ounces per square yard (407 to 475 g/m²).

2.3 Number of specimens.

2.3.1 Forty specimens shall be taken from the sample unit. Twenty of the specimens shall be retained unburied and subjected to the same physical tests as the twenty buried specimens for the purpose of comparison to determine the degree of mildew resistance of the affected specimens.

3* NUMBER OF DETERMINATIONS

3.1 Unless otherwise specified in the procurement document, 20 determinations shall be made on each sample unit for a change of characteristic.

FED. TEST METHOD STD. NO. 191A

METHOD 5762

4. APPARATUS AND METHODS CITED

4.1 Soil bed. The soil shall be composted of equal parts of:

- a. Good topsoil (soils with high clay content should not be used).
- b. Well rotted and shredded manure of leaf mold.
- c. Course sand (sand of a 10 or 40 mesh is best).

The soil shall be rich with microbial life which decomposes cellulose as determined in 5.4. The soil shall not tend to pack closely or become sticky when damp. The soil mixture shall be aged 3 months at 82 to 86°F (27 to 30°C) before use and mixed after each 2 weeks of aging. If at the end of 3 months aging the soil fails to degrade untreated cloth when tested as specified in 5.4 the aging should be continued until it does. Aged soil can be stored and reused indefinitely so long as activity can be demonstrated when tested as specified in 5.4.

4.1.1 The soil shall be maintained at between 20 and 30 percent moisture, based on the dry weight of the soil, at a temperature of 82 to 86°F (28° to 30°C). Water lost during use due to evaporation shall be replaced without deforming the soil bed. If the surrounding atmosphere is maintained at 85 to 95 percent relative humidity this loss is negligible.

4.1.2 The soil shall be adjusted to a pH between 6.5 and 7.5. Periodic tests and adjustments should be made to maintain the soil within the desired range by addition of appropriate amounts of calcium carbonate or agricultural ground limestone to raise pH, or flowers of sulfur to lower the PH.

4.2 Soil container. The container shall be of wood (Cypress or Redwood recommended) or other suitable material such as plastic or stainless steel in a size which is convenient to handle and having a depth of at least 5 inches (127 mm).

4.3 Incubator. Incubator room or cabinet maintained at a temperature of 82° to 86°F (28° to 30°C), and a relative humidity of 85 to 95 percent.

4.4 Methods cited.

- Method 4100, Strength and Elongation, Breaking; and Tenacity; of Thread and Yarn; Single Strand.
- Method 5104, Strength and Elongation, Breaking of Woven Cloth; Ravel Strip Method.
- Method 5830, Leaching Resistance of Cloth; Standard Method.
- Method 6015, Strength and Elongation, Breaking of Cordage; Spliced Specimen Method.
- Method 6016, Strength and Elongation, Breaking of Cordage, Non-Spliced Specimen Method.

FED. TEST METHOD STD. NO. 191A

METHOD 5762

5. PROCEDURE

5.1 Unless otherwise specified in the procurement document, the specimen shall be leached as described in Method 5830, before exposure to mildew.

5.2 Unless otherwise specified in the procurement document, the resistance to mildew shall be determined by the change in breaking strength using Method 5104 for cloth; Method 4100 for yarn and thread; Method 6016 for light cordage and webbing; and Method 6015 for rope.

5.3 Unless otherwise specified in the procurement document, the specimen shall be exposed in the incubator 2, 4, 6, 8 and 12 weeks. The test may be terminated at any interval if the samples have lost at least 50 percent of their tensile strength.

5.4 Viability control. Untreated material shall be exposed in the soil bed every 10 days throughout the periods of test in order to verify the microbial activity of the soil. The soil shall be considered to be satisfactory if the untreated controls lose not less than 50 percent of their tensile strength in 5 days.

5.5 Exposure. The specimen after being wet-out (see 5.1) shall be buried in the soil.

5.5.1 The specimen shall be placed flat on a 4 inch (102 mm) bed of soil, spaced at least 1 inch (25 mm) from any other specimen and covered with 1 inch (25 mm) of loose soil.

5.5.2 When a specimen of rope is exposed, 1 foot (305 mm) of the center portion of the specimen shall be buried to a depth of about 4 inches (102 mm) and the ends of the spliced specimen from the end of the splice to the end of the eye, shall be held out of contact with the soil.

5.6 Evaluation. At the end of the exposure period the specimen shall be removed from the soil bed and, if not extensively degraded, gently washed to remove soil, air-dried and then conditioned to equilibrium according to Section 4 of this Standard. At the end of the conditioning period the breaking strength, if required, shall be determined as described in 5.2. If other physical tests are required the specimen shall be tested as described in the required method. The same physical tests shall be conducted on exposed and unexposed specimens for the purpose of comparison in determining the degree of mildew resistance of the affected specimens.

5.7 Calculation of results. The change in breaking strength or other characteristic of the specimen shall be calculated as follows:

$$\text{Change in characteristic, percent} = \frac{O - E}{O} \times 100$$

METHOD 5762

Where: O = Value before exposure to mildew.
E = Value after exposure to mildew.

6. REPORT

6.1 The change in breaking strength or other characteristic of the sample unit after exposure to mildew shall be the average of the results obtained from the specimens tested and shall be reported as "percent change" to the nearest 1.0 percent.

6.2 Each individual value used to calculate the average shall also be reported.

METHOD 5764
July 20, 1978

INSECT RESISTANCE OF TEXTILE MATERIALS

1. SCOPE

1.1 This method is intended to be used to evaluate the effectiveness of chemical insect deterrents applied to textile materials. This is accomplished by measuring quantitatively the amount of feeding (extent of damage) by a specified number and type of insects for a prescribed time under controlled temperature and humidity.

2. TEST SPECIMEN

2.1 The specimen shall be free of any solvents or carriers used in the application of chemical treatments and of any solvents or auxiliary agents used in subsequent durability tests.

2.2 The required specimens shall be as follows:

2.2.1 Treated specimens.

2.2.1.1 Cloth. Each specimen shall have an area of two square inches (1290 mm²) and cut from the sample unit so that no two specimens contain the same warp and/or filling yarns.

2.2.1.2 Yarn. Each specimen shall be prepared by uniformly winding one layer of yarn on a square or rectangular piece of glazed cardboard, glass, or metal with an area of two square inches (1290 mm²). The surface of the cardboard, glass, or metal shall be covered substantially by the yarn.

2.2.1.3 Carpet. Each specimen shall have an area of two square inches (1290 mm²) and cut from the sample unit so that no two specimens contain the same warp and/or filling yarns. The edges of the specimens are secured by coating the backing yarns with cellulose nitrate dissolved in acetone. For the cloth weight loss method, specimens are prepared by stapling pieces of yarn removed from the sample unit to pieces of glazed paper, each having an area of two square inches (1290 mm²) so that the surface is covered substantially by the yarn.

2.2.2 Untreated specimens. The specimens shall be as specified in 2.2.1 except that they shall be cut from the same material as in 2.2.1 before it has been treated with insect deterrent.

2.2.3 Standard control specimens. The specimens shall be as specified in 2.2.1 except that they shall be cut from a standard control cloth.

FED. TEST METHOD STD. NO. 191A

METHOD 5764

3. NUMBER OF DETERMINATIONS

3.1 Unless otherwise specified in the procurement document, four specimens shall be tested from each sample unit.

4. APPARATUS, MATERIALS, INSECTS

4.1 Apparatus.

4.1.1 Test cages. Each cage may be any glass or metal flat-bottomed container large enough to permit the test insects to be either in contact with or off the horizontally placed test specimen. It must be well ventilated and provided with a 60-mesh metal screen cover.

4.1.2 No. 3 Gooch crucibles.

4.1.3 Analytical balance accurate to ± 0.2 mg.

4.1.4 Incubator - capable of maintaining a temperature of $81^{\circ} \pm 2^{\circ}\text{F}$ ($27^{\circ} \pm 1^{\circ}\text{C}$) and a relative humidity of 55 ± 5 percent and light excluded.

4.1.5 U.S. Standard Sieve Series Screens Nos. 8, 14, 16, 20, and 40.

4.1.6 Forceps.

4.1.7 Soft hair brush.

4.1.8 Air vacuum apparatus.

4.2 Material.

4.2.1 Standard control cloth. Pure, undyed, scoured wool fabric (see 7.1).

4.3 Insects.

4.3.1 Black Carpet Beetle (*Attagenus piceus* (Oliv.), (see 7.6)). Larvae are used from cultures maintained as described in the Appendix. Larvae must be in the weight range of 6 to 7 mg each, and of such a size that they pass through a U.S. Standard Sieve Series No. 14 sieve, and are retained on a No. 16 sieve as described in Appendix.

4.3.2 Furniture Carpet Beetle (*Anthrenus flavipes* (LeConte), (see 7.6)). Larvae from cultures maintained as described in the Appendix may be used as alternative test insects with the black carpet beetle.

METHOD 5764

4.3.3 Webbing Clothes Moth (*Tineala bisselliella* (Hum) (see 7.6)). Larvae are used from cultures maintained as described in the Appendix. Larvae must be 25 to 27 days old as measured from the date of egg deposition to the time they are put on test since older larvae may pupate during the test period.

5. PROCEDURE

5.1 Control specimens for insect activity.

5.1.1 Control specimens of the standard control cloth shall be exposed to the same conditions as the test specimens.

5.1.2 Each lot of cloth used for control specimens and lots of cloth used as rearing medium shall be thoroughly checked to determine suitability prior to use.

5.2 Excrement weight method for carpet beetles.

5.2.1 Three sets of specimens of four specimens each, one set from the material to be tested, one set from the untreated material and one set from the standard control cloth prepared as specified in paragraph 2 shall be freed of any loosely adhering dirt or dust, (see 7.7), and placed face down in separate test cages. The four specimens of untreated material tested are for comparison purposes only.

5.2.2 Ten larvae as specified in 4.3.1 or 4.3.2 are placed on top of each specimen and the cages covered with 60-mesh screening.

5.2.3 The cages containing the test specimens and larvae are kept for 14 days at $81^{\circ} \pm 2^{\circ}\text{F}$ ($27^{\circ} \pm 1^{\circ}\text{C}$), and 55 ± 5 percent relative humidity. Light shall be excluded.

5.2.4 Immediately after the 14 day period, remove and record the number of living and dead insects. Survival counts shall be made in all cases. Since they are important in demonstrating the vitality of the test larvae.

5.2.5 Damage to a test specimen is determined by the quantity of excrement deposited on the test specimen during the time period.

5.2.5.1 Remove the test specimen from the cage and by alternately tapping and brushing, transfer all loose material, excrement, exuvial, etc., back into the test cage.

5.2.5.2 Transfer contents of test cage into a No. 3 Gooch crucible and, by repeated tapping of the crucible, the excrement is sifted through the perforations into one of a pair of matched watch glasses. For the purpose of this test all the material that sifts through the perforations of the Gooch crucible shall be construed as excrement.

METHOD 5764

5.2.5.3 Weigh the excrement on an analytical balance accurately to the nearest 0.2 mg and record.

5.2.6 Evaluation.

5.2.6.1 The test specimen is considered satisfactorily resistant to carpet beetles if an average quantity of excrement of not over 5 mg per specimen is deposited, provided that no single specimen shows more than 6 mg of excrement and that under the same conditions, the controls show an average quantity of excrement of not less than 15 mg per specimen.

5.2.6.2 The test is invalid if the quantity of excrement deposited on the control specimens average less than 15 mg per specimen, or if less than 90 percent of the control larvae survive.

5.3 Cloth weight loss method for carpet beetle and clothes moths.

5.3.1 Three sets of specimens of eight specimens each, one set from the material to be tested, one set from the untreated material and one set from the standard control cloth are used for this method. Four specimens from each set shall be used for feeding tests and the other four shall be used as humidity checks. The specimens from the untreated material are tested for comparison only.

5.3.1.2 The four specimens from each set that are used for humidity checks are exposed to the same conditions as the feeding test specimens except that larvae are not used. A change in the weight of the humidity check specimens will be due to change in moisture content only and shall be used to adjust the weights of the feeding test specimens.

5.3.2 The feeding test specimens and the humidity check specimens from each set are freed of any loosely adhering dirt or dust and placed in separate test cages at $81^{\circ} \pm 2^{\circ}\text{F}$ ($27^{\circ} \pm 1^{\circ}\text{C}$) and 55 ± 5 percent relative humidity for 48 hours before weighing.

5.3.3 Weigh the specimens on an analytical balance to the nearest 0.2 mg alternating the weighings between the test specimens and the humidity check specimens and record in the order of the weighings.

5.3.4 Ten larvae of the required insects (see 4.3) are placed on each feeding test specimen and the test cages covered with 60-mesh screen.

5.3.5 The test specimens and humidity check specimens are kept for 14 days at $81^{\circ} \pm 2^{\circ}\text{F}$ ($27^{\circ} \pm 1^{\circ}\text{C}$) and 55 ± 5 percent relative humidity. Light shall be excluded.

METHOD 5764

5.3.6 Immediately after the 14 day period, remove and record the number of living and dead insects. Survival counts shall be made in all cases. Since they are important in demonstrating the vitality of the test larvae.

5.3.7 Damage to the test specimens is determined by weight loss of the specimen due to the feeding of the larvae as follows:

5.3.7.1 Brush the specimens to free them of all loose material such as excrement, webbing cast skins, loose fibers etc. Forceps are usually necessary to remove masses of webbing and excrement from clothes moths, test specimens and containers.

5.3.7.2 The cleaned test specimens and the humidity check specimens shall be reconditioned at $81 \pm 2^{\circ}\text{F}$ ($27^{\circ} \pm 1^{\circ}\text{C}$) and 55 ± 5 percent relative humidity for not less than 24 hours.

5.3.7.3 The test specimens, and the humidity check specimens shall be weighed on an analytical balance to the nearest 0.2 mg and recorded in the same manner as specified in 5.3.3 and under conditions specified in 5.3.7.2.

5.3.7.4 Humidity check shall show not more than 5 percent variation in weight before and after the test.

5.3.7.5 The loss of weight, in mg, due to the feeding of the test larvae, as adjusted for humidity changes, shall be calculated as follows:

$$L = \frac{AC}{B} - D$$

Where: L = adjusted loss of weight in mg due to insect feeding;
A = average weight of the four test specimens before testing;
B = average weight of the four humidity control specimens before testing;
C = average weight of the four humidity control specimens after testing;
D = average weight of the four test specimens after testing.

This formula is applicable regardless of whether the humidity control specimens gain or lose weight.

5.3.8 Evaluation.

5.3.8.1 The tested textile is considered satisfactorily resistant to the insect pests used, if the average loss of weight due to feeding is not more than 8 mg, provided that under the same conditions the average loss in weight of the control specimens is not less than 30 mg. No individual test specimen shall show more than 10 mg loss in weight.

METHOD 5764

5.3.8.2 The test is invalid if the amount of feeding results in less than 30 mg average weight loss per control specimen or less than 75 percent of the control larvae survive.

6. REPORT

6.1 Excrement weight method (see 5.2). The specimen tested shall be reported as "pass" or "fail" and the report shall also contain the following information.

6.1.1 Weight of excrement in mg of each test specimen and standard control specimens. The number of larvae alive at the conclusion of the test.

6.2 The cloth weight loss method (see 5.3). The specimens tested shall be reported as "pass" or "fail" and the report shall also contain the following information.

6.2.1 Individual weights of the test specimens and humidity check specimens before and after the testing.

6.2.2 Loss in weight of each test specimen and standard control specimen.

6.2.3 Number of larvae alive at the conclusion of the test.

6.2.4 Number of larvae pupated.

7. NOTES

7.1 MTCC moth test cloth is a standard pure, undyed, scoured wool fabric and is available from Test Fabrics, Inc., 55 Van Dam Street, New York, N.Y. 10013.

7.2 Purina Laboratory Chow Meal may be ordered from Ralston Purina Company, P.O. Box 240, Davenport, IA.

7.3 Gaines Dog Meal is available locally or from General Foods Corporation, P.O. Box 60, Youngstown, OH 44501.

7.4 Yeasts which have proven satisfactory are (a) Brewer's Yeast Powder, Mead Johnson Company, available at most drug stores; (b) Dry Brewer's Yeast, U.S.P. from Yeast Products, Inc., 455 Fifth Avenue, Patterson, NJ with a minimum potency, per gram, of 150 micrograms thiamine, 45 micrograms riboflavin and 400 micrograms niacin.

7.5 Fish meal is available from National Sea Products LTD., 39 Upper Water Street, Halifax, Nova Scotia, Canada.

FED. TEST METHOD STD. NO. 191A

METHOD 5764

7.6 Insect larvae are available from Crop Protection Institute, Durham, NH 03824; and Wisconsin Alumni Research Foundation, P.O. Box 2037, Madison, WI 53701.

7.7 No. 3 Special Filter Cloth from Mechanical Felt and Textiles Company, 50 W. 18th St., Weehawken, NJ and No. 70105 all-Wool Felt color 10 White, from the American Felt Company, 315 Fourth Avenue, New York, NY Specific fabrics used for rearing moths must be free from insecticides.

7.8 It is extremely important that contamination, dirt, and dust be removed from the test specimens since it could be included later in the excrement weight. The test specimens, if their construction permits, can be vacuumed with the open end of a vacuum cleaner hose nozzle to remove dirt and other particles which might interfere with the subsequent determination of the excrement weight. It is suggested that each specimen be cleaned further by alternately tapping and brushing the specimens to rid them of any loose material such as dust, immediately before the specimens are subjected to testing.

APPENDIX

PROCEDURE FOR REARING AND HANDLING TEST INSECTS

1. SCOPE

1.1 The standardized procedure for rearing test insects is an essential part of the standard test procedure for determining resistance of fabrics to insect pests. The following procedures are to be used for rearing the black carpet beetle (*Attagenus piceus* (Oliv.)), webbing clothes moth (*Tineola bisselliella* (Hum)), and furniture carpet beetle (*Anthrenus flavipes* (LeConte)).

2. APPARATUS; MATERIAL

2.1 Rearing containers, wide mouth glass jars of 1 or 2 quart (0.95 or 1.9 L) capacity or any other suitable type container such as mason jars, battery jars, or tin cans with lids replaced by coarse filter paper, screens or cloth covers.

2.2 Oviposition cage. A tin can 6-1/2 inches (165 mm) high and 6 inches (152 mm) in diameter. The bottom is removed and replaced with 16-mesh screen wire. Wool flannel is placed beneath the screen and supported in place by a cardboard circle fastened with masking tape to the rim of the can. A closure for the culture jars is soldered in place in an inverted position in the center of the lid of the can and an opening 2 inches (51 mm) in diameter is cut in the can lid within the area inclosed by the closure.

2.3 Rearing medium.

2.3.1 Clean, scoured, undyed wool cloth supplemented with about one teaspoonful of autoclave (15 p.s.i. (103 kPa) for 15 min.) dry Brewer's yeast or fish meal to each 30 g of cloth (see 7.4 and 7.5).

2.3.2 Purina Laboratory Chow Meal (see 7.2) which passes through U.S. Standard Sieve Series Screen No. 16, with the coarse fraction discarded, or

2.3.3 95 percent by weight Gaines Dog Meal ground to pass through No. 20 screen plus 5 percent dry Brewer's yeast (see 7.3, 7.4).

2.4 Fumigant carbon disulfide.2.5 Mold inhibitor propionic acid.2.6 Soft hair brush.2.7 Kraft paper.

METHOD 5764

2.8 Entomological forceps.2.9 1/2 inch (13 mm) glue brush.

3. PROCEDURE

3.1 Black carpet beetle.

3.1.1 Sterilize the rearing medium to kill mites or insects that may be present. This may be done by an efficient fumigant (1 ml carbon disulfide per gallon) preferably in sealed glass containers for one week, dry heat (176°F (80°C) for four hours or 212°F (100°C) for one hour) or autoclave at 15 p.s.i. (103 kPa) for 15 minutes. Fumigated medium must be spread in shallow trays and cured in a ventilated hood for one or more days. Overheating may destroy the food value of the medium.

3.1.2 Store the sterile medium in sealed containers. Before using, dry the medium and adjust to 13 percent moisture by adding distilled water.

3.1.2.1 To dry the medium spread a quantity of medium to a depth of 1/2 to 3/4 inch (13 to 19 mm) in trays and dry to a constant weight (30 to 44 hours) in a forced draft oven at 151°F (66°C). Cool the medium and temper to 13 percent moisture immediately.

3.1.2.1.1 Tempering to 13 percent moisture. Determine the total weight of the medium and for each 100 g, prepare 15 ml distilled water plus 0.38 ml propionic acid. Sieve the medium through a No. 20 screen. Add the combined water and propionic acid to the coarse fraction retained on the screen. Finally pour from tray to tray several times, pass through a No. 16 screen and place in sealed containers until needed for cultures. The final mixture should contain 13 percent moisture and 0.38 percent propionic acid.

3.1.3 The rearing room or incubator shall have a constant temperature of 81° ± 2°F (27° ± 1°C) and a relative humidity of 55 ± 5 percent.

3.1.4 Maintenance of cultures. It is possible to maintain cultures of the black carpet beetle so that larvae of testing size and age are available at all times. This can be accomplished only when overcrowding is prevented and cultures are kept well supplied with food.

3.1.5 The black carpet beetle completes its life cycle in 8 to 10 months when reared and handled under optimum conditions as follows:

3.1.5.1 Once each week, pass maturing stock larvae cultures through a U.S. Standard Sieve Series Screen No. 16 and collect adults and prepare separately. The majority of the pupae and the mature larvae can be separated by spreading them out on Kraft paper. The larvae tend to cling to the paper

METHOD 5764

when it is rolled and tilted to an upright position over a pan. The pupae fall into the pan and then the clinging larvae can be shaken into another pan. A No. 8 screen is useful for separating the small number of larvae still remaining with the pupae. The pupae are kept in a screen covered jar for one week for emergency. Count out 50 adults at random and measure their volume in a 15 ml centrifuge tube. The volume of 50 adults should be 1.2 to 1.5 ml if they are developed normally. Transfer the adults to a pint (0.47 L) jar three-fourths full of rearing medium (containing 13 percent water). Cover the jar with a filter paper lid and set aside to age at $81^{\circ} \pm 2^{\circ}\text{F}$ ($27^{\circ} \pm 1^{\circ}\text{C}$), and 55 ± 5 percent relative humidity.

3.1.5.2 The majority of eggs are laid during the next ten days, and these hatch 6 to 12 days after laying. The eggs are too fragile to be handled without injury and the jar must not be disturbed for at least 11 weeks. At this time, pass its contents through a No. 20 screen. A gentle stream of air, such as is produced by a hair dryer, is useful in removing cast skins. The larvae and coarse material (dead adults, coarse food particles, etc.) retained on the No. 20 screen are then separated by placing the material on the high end of a sloping platform or tray. By putting a light over this end, the larvae, since they are negatively phototrophic, will crawl away from the coarse material and collect at the other end of the tray. The collected larvae are then allowed to crawl through a nest No. 14, No. 16, and No. 20 screens under a light. After 5 minutes, the contents of the screens can be emptied into separate trays. Larvae caught in the mesh are gently stimulated with a soft brush to crawl through the screen or they can usually be removed without injury with Ward's feather-weight entomological forceps. Mites may be removed from the larvae, pupae, or adults by placing the infested insects in a jar that is half-filled with sterilized rearing medium and rotating the jar, screening to separate larvae from the medium and destroying or sterilizing this food which contains mites. It may be necessary to repeat this procedure several times.

3.1.5.3 Measure the volume of larvae collected in a centrifuge tube and estimate the percentage represented by each fraction, based on total numbers. For this purpose, 1 ml contains approximately 45 larvae held on a No. 14 screen, 70 larvae on a No. 16 screen, and 90 larvae held on a No. 20 screen. The number of larvae passed through the No. 20 screen should be estimated roughly and made a part of the total. If 10 to 20 percent of the larvae are not of a size to be held on the No. 14 screen, return all fractions of the larvae and medium to the same jar and age one or two weeks longer. The above step is quite important if satisfactory test larvae are to be obtained. When the jar first produces 10 to 20 percent of larvae held on the No. 14 screen, collect 6 ml of the larvae held on the No. 16 screen (approximately 400), pass them through sterile medium to remove mites, and transfer to quart (0.95 L) jar $\frac{3}{4}$ full with medium. Save the remaining larvae held on the No. 16 screen for tests and discard the larvae held on the No. 14 and the No. 20 screens. Add 6 ml of larvae held on a No. 16 screen from new cultures on each of the following three weeks before starting a new jar. These are stock larvae cultures, which

METHOD 5764

will produce pupae 6 to 8 months later. Three months and five months after starting the stock cultures, remove larvae from medium by a No. 16 screen as described in 3.1.5.2 and transfer to fresh medium.

3.1.5.4 At the time the stock larvae are collected, test larvae may be collected by means of the No. 14 and No. 16 screen. Larvae held on the No. 16 screen are test size, and they average 6 to 7 mg in weight. The unused larvae held on the No. 16 screen can be saved for possible use as test larvae that same week. All remaining larvae should be discarded at the end of the week.

3.1.5.5 A few weeks experience will determine the age of cultures meeting the requirements for sizing and use of larvae. A deviation of more than one week from this age indicates an abnormal rearing condition which may be caused by food, mites, or various other conditions. Abnormal cultures should be discarded.

3.2 Webbing clothes moth, (*Tineala bisselliella* (Hum)).

3.2.1 Adult moths are transferred to the oviposition cage and allowed to deposit their eggs for 2 to 4 days.

3.2.1.1 The adult moths may be transferred to the pint (0.47 L) jar either by use of a suitable suction or by introducing into the container with the adults, a small amount of carbon dioxide (CO₂) gas which will facilitate the transfer of the moths.

3.2.1.2 When the 6-1/2 inch (165 mm) high by 6 inch (152 mm) diameter can is used, the culture jar with the adult moths is fastened in place in the closure and a bright light shined on the glass culture jar to drive the adults into the oviposition cage.

3.2.2 The pieces of cloth on which the eggs have been deposited are removed from the cage, placed in an enamel pan and vigorously brushed with a 1/2 inch (13 mm) glue brush to remove the eggs. The adult moths are removed from the cage and destroyed. Since the eggs hatch in 4 days, this is the maximum interval that may be allowed between egg collections.

3.2.3 The eggs are screened through a 40-mesh sieve and retained on a 60-mesh sieve. The eggs are measured in a graduated centrifuge tube, 0.2 ml representing approximately 4000 eggs.

3.2.4 The eggs are sprinkled on 4 by 10 inch (102 by 254 mm) strips of clean scoured wool fabric (total 25 to 30 g) treated with about 1 teaspoonful of dry yeast. The wool strips are rolled up and placed in a one or two quart (0.95 or 1.9 L) wide-mouthed jar, covered with filter paper lids and kept at 81° ± 2°F (27° ± 1°C) and a relative humidity of 55 ± 5 percent for 25 to 27 days as measured from the date of egg deposition to the time used for test (see 7.7).

METHOD 5764

3.2.5 All moths that are older than required for testing shall be destroyed or kept for the purpose of maintaining a quantity of insects of testing age.

3.3 Furniture carpet beetle, (*Anthrenus flavipes* (LeConte)).

3.3.1 Place approximately 60 pupae in a rearing container with several 3 inch by 3 inch (76 by 76 mm) squares of wool cloth supplemented with dry Brewer's yeast or fish meal (see 7.4 and 7.5).

3.3.2 Examine rearing jars at weekly intervals and provide sufficient supplemental wool cloth to maintain an adequate food supply.

3.3.3 About eleven weeks after the pupae were placed in the rearing jars, the larvae are removed from the wool cloth, excrement, pupae cases, etc. After removing the excrement and excess Brewer's yeast with a 40-mesh sieve, larvae clinging to the cloth can be removed with a soft brush. If handled carefully, the larvae may also be transferred with light forceps.

3.3.4 The collected larvae are then allowed to crawl through nested No. 14, 16, and 20 screens under a light. The larvae held on the No. 20 screen are test size and average 1.0 to 1.5 mg in weight. If more than half of the larvae pass through the No. 20 screen, return all fractions of the larvae and medium to the same jar and age one week longer. A few weeks experience will determine the age of larvae meeting the requirements for sizing and use.

3.3.5 A portion of the larvae not used for tests can be placed in a large stock jar which serves as a source supply for pupae for the rearing jars.

WEATHERING RESISTANCE OF CLOTH;

NATURAL WEATHERING METHOD

1. SCOPE

1.1 This method is intended for determining the resistance to deterioration of cloth when subjected to a prolonged period of outdoor exposure. It is applicable to cloth of all kinds.

2. TEST SPECIMEN

2.1 The specimen shall be of such form and dimension to provide the material required in the specified evaluation tests.

3. NUMBER OF DETERMINATIONS

3.1 Unless otherwise specified in the procurement document, the number of specimens tested from each sample unit shall be as required in the method of test used for determining the characteristic.

4. APPARATUS AND METHODS CITED

4.1 Apparatus.

4.1.1 Specimen rack. The rack shall be a wooden frame open at the back to allow free access of air to the specimen and providing means of fastening the top and bottom edges of the specimens to it. The fasteners used must not be made of corrodible materials.

4.1.2 Exposure area. A place unprotected from the sun and in the town and state specified in the procurement document. Unless otherwise specified in the procurement document, the cloth shall be exposed in a nonindustrial area.

4.1.3 Eppley Pyranometer or equivalent device. A detector used in the measurement of the radiant energy of the sun at the exposure area. The Epply Pyranometer is a differential thermopile with the hot - junction blackened and the cold - junction whitened, it measures the radiation for a complete hemisphere of the sky. The thermopile is covered by a precision ground, optical glass envelope which is usefully transparent from about 280 to 2800 nm and is replaceable. The EMF generated by the thermopile is recorded by a suitably integrated potentiometer (see 7.1).

4.1.4 Means of recording the prevailing weather conditions.

METHOD 5800

4.2 Method cited.

Method 5100, Strength and Elongation, Breaking of Woven Cloth;
Grab Method.

5. PROCEDURE

5.1 Standard sample. When a standard sample has been established, a specimen of the standard sample shall be exposed at the same time and under the same conditions as the specimen undergoing test.

5.2 No standard sample. When a standard sample has not been established, the test specimen shall be exposed, and an equal and adjacent area of the original cloth shall be retained for comparison.

5.3 The specimen shall be mounted on the frame, without tension, by securing the edges with staples, tacks, or other suitable means. The warp direction of the specimen shall be in the vertical position and shall be indicated on the reverse side of the specimen unless a selvage is present.

5.4 The specimen on the rack shall be exposed facing due south (or north if exposed in the southern hemisphere) at an angle of 45 degrees from the horizontal. The rack shall be at least 2 feet (610 mm) from the ground or vegetation.

5.5 The specimen shall be exposed for the required period or for a time sufficient to provide a quantum of radiant energy equal to the required number of langley (MJ/m²).

5.5.1 During the exposure period, the radiant energy shall be measured by means of the Eppley Pyranometer or equivalent instrument and the weather condition recorded. The pyranometer shall be exposed at the same angle and under the same conditions as the specimen.

5.6 At the end of the required exposure period, the specimen shall be removed from the exposure area and placed, while dry, in a protected place.

5.7 Within 3 weeks after withdrawal from exposure, the specimen shall be subjected to the required evaluation tests.

5.8 Calculation of results. Unless otherwise specified in the procurement document, the resistance to deterioration shall be evaluated as the change in breaking strength of the weathered specimens when tested by the procedure described in Method 5100. If other physical properties are required, the specimen shall be tested as described in the required method. The evaluation tests shall be made only on that part of the specimen which was fully exposed and not protected by the frame or damaged when secured to the frame or rack. The change in breaking strength or other characteristics shall be calculated as follows:

METHOD 5800

Change in characteristics, percent = $\frac{O - E}{O} \times 100$ or $\frac{E - O}{O} \times 100$

Where O = value before weathering deterioration.

E = value after weathering deterioration.

5.8.1 Standard sample. When a standard sample has been established, the same evaluation tests shall be performed on the weathered test specimens and on the weathered specimens from the standard sample. Unless otherwise specified in the procurement document, the resistance to weathering shall be expressed as "Satisfactory" or "Unsatisfactory".

Satisfactory: When the percent change in characteristic of the sample unit is equal to, or less than, or more than, as applicable, the percent change of the standard.

Unsatisfactory: When the percent change in characteristic of the sample unit is greater than, or less than, as applicable, the percent change of the standard.

5.8.2 No standard sample. When a standard sample has not been established, the same evaluation tests shall be performed on the weathered test specimens and on the unweathered specimens. The resistance to weathering shall be expressed as the change in breaking strength or other characteristic, calculated to the nearest 1.0 percent.

6. REPORT

6.1 The locations of the exposure, town and state, and whether or not the area is nonindustrial shall be reported.

6.2 The specific dates and duration of the exposure period or the total radiation in langleys (MJ/m²) shall be reported.

6.3 Standard sample. Unless otherwise specified in the procurement document, when a standard sample has been established, resistance to weathering shall be reported as "Satisfactory" or "Unsatisfactory".

6.4 No standard sample. Unless otherwise specified in the procurement document, when a standard sample has not been established, change in breaking strength or other characteristic shall be reported to the nearest 1.0 percent.

7. NOTES

7.1 A machine of the type described may be purchased from the Eppley Laboratory Inc., Newport, RI 02840.

WEATHERING RESISTANCE OF CLOTH;

ACCELERATED WEATHERING METHOD

1. SCOPE

1.1 This method is intended for determining the resistance to deterioration of cloth when subjected to accelerated weathering exposure. It is applicable to cloth of all kinds.

2. TEST SPECIMEN

2.1 The specimen shall be of such form and dimension to provide the material required in the specified evaluation tests.

3. NUMBER OF DETERMINATIONS

3.1 Unless otherwise specified in the procurement document, the number of specimens tested from each sample unit shall be as required in the method of test used for determining the characteristic.

4. APPARATUS

4.1 The weathering machine shall be the XW type or equivalent (see 7.1).

4.1.1 Vertical carbon arc mounted at the center of a vertical cylinder.

4.1.1.1 The arc shall be designed to accommodate either two or three pairs of carbons but shall burn only one pair at a time, automatically transferring from one pair to another as the carbons are consumed.

4.1.1.1.1 The carbons shall be Copper Clad Sunshine Arc Type, No. 22 for the upper pair and No. 13 for the lower pair.

4.1.2 The arc shall be operated on 60 A and 50 V across the arc for alternating current and on 50 A and 60 V across the arc for direct current.

4.1.3 Removable panels (filters) of Corex D glass, or other enclosure having equivalent absorbing or transmitting properties, shall surround the arc.

4.1.4 A rotating rack with holders in which the specimens are suspended vertically and normally to radiation from the arc with the center of the face of the specimen at a radial distance of approximately 18 inches (457 mm) from the arc.

METHOD 5804

4.1.5 Water-spray nozzles shall be mounted horizontally (the water-spray assembly vertically) in the test chamber inside the specimen rack and so placed that the water shall strike the specimens evenly over their entire length in the form of a fine spray in sufficient volume to cover specimens immediately on impact. The apparatus shall be so operated that the specimens are exposed to successive cycles of 102 minutes of light without spray and 18 minutes of light with spray.

4.1.6 Means for maintaining the required temperature of water in the spray.

4.1.7 Means for maintaining the required pressure of water entering the spray.

4.1.8 Means for delivering the required quantity of water per spray nozzle to the specimen.

4.1.9 Exhaust fan to ventilate the arc effectively.

4.1.10 Black panel thermometer unit for measuring the temperature within the machine. This unit shall consist of a metal panel to the base of which is attached the sensitive portion of a bimetallic dial type thermometer. The entire base is then coated twice with long lasting baked enamel paint.

4.1.11 The weathering machine shall be located in an area free from drafts with ambient temperature between 70 and 95°F (21 and 35°C) and 40 to 80 percent relative humidity.

5. PROCEDURE

5.1 The number of hours of exposure shall be as specified in the procurement document.

5.2 Unless otherwise specified in the procurement document, the filters shall not be removed during exposure. When exposure without filters is specified, only the Corex D glass filters shall be removed. The stainless steel frames shall remain in place.

5.3 When a standard sample has been established, a specimen of the standard sample shall be exposed at the same time and under the same conditions as the specimens undergoing test.

5.4 When no standard sample has been established, the test specimen shall be exposed and an equal adjacent area of the original material retained but not exposed.

FED. TEST METHOD STD. NO. 191A

METHOD 5804

5.5 The rack shall rotate about the arc at a uniform speed of one revolution per minute.

5.6 The temperature of water in the spray shall be $80^{\circ} \pm 10^{\circ}\text{F}$ ($27^{\circ} \pm 5^{\circ}\text{C}$).

5.7 The pressure of the water entering the spray shall be 12-18 psi (83-124 kPa).

5.8 The quantity of water delivered to the specimens shall be 0.9 to 1.2 gallons; (3.4 to 4.5 L) per hour per spray nozzle.

5.9 The black panel temperature at the exposure plane of the specimen rack shall be $155^{\circ} \pm 10^{\circ}\text{F}$ ($68^{\circ} \pm 5^{\circ}\text{C}$) when the filters are in place and $175^{\circ} \pm 10^{\circ}\text{F}$ ($79^{\circ} \pm 5^{\circ}\text{C}$), when the filters are removed when measured in the following manner:

5.9.1 Before reading the temperature, the racks in the machine shall be fully loaded with specimens except for the black-panel and shall be in operation long enough for thermal equilibrium to be established.

5.9.2 The black panel shall be mounted in the test-panel rack and readings taken at the point where water spray is not striking the panel.

5.10 The specimen shall be suspended on the rack without tension and in such a way that the ends or corners cannot curl.

5.10.1 The warp direction of the specimen shall be in the vertical position and shall be indicated on the reverse side of the cloth.

5.10.2 No test portion of the specimen shall be more than 7 inches (178 mm) above or below the horizontal plane of the arc.

5.11 Unless otherwise specified in the procurement document, the filters shall be in place and the spray shall be operating.

5.12 The specimen shall be exposed to normal radiation from the arc for the required period of time.

5.13 The filter frames shall be numbered 1 through 8 with permanent numbers. The filters shall be thoroughly cleaned after each cycle. One filter shall be removed and discarded after each 250 hours of operation; that is filter #1 should be removed and replaced with a new filter after 250 hours, filter #2 after 500 hours, filter #3 after 750 hours, filter #4 after 1,000 hours, until all filters have been changed. The procedure shall then be repeated. A record shall be maintained showing when filters were changed.

METHOD 5804

5.14 At the end of the required exposure period, the specimen shall be removed from the machine and allowed to dry.

5.15 The characteristics and methods for determining the resistance to deterioration shall be specified in the procurement document. The evaluation tests shall be made only on that part of the specimen which was fully exposed and not protected by the frame or damaged when secured to the rack.

5.15.1 Standard sample. When no standard sample has been established, the same tests shall be conducted on the weathered material undergoing test and on the weathered standard.

5.15.2 No standard sample. When no standard sample has been established, the same tests shall be conducted on the weathered and unweathered specimens for the purpose of comparison in determining the degree of deterioration of the exposed cloth.

5.16 Calculation of results. Percent change in the characteristic shall be calculated as follows:

$$\text{Change in characteristic, percent} = \frac{O-E}{O} \times 100 \quad \text{or} \quad \frac{E-O}{O} \times 100$$

Where: O = value before weathering deterioration.
E = value after weathering deterioration.

6. REPORT

6.1 The number of hours of exposure shall be reported.

6.2 Exposure unprotected by filters shall be reported.

6.3 Standard sample. Unless otherwise specified in the procurement document, when a standard has been established, resistance to weathering shall be reported as "Satisfactory" or "Unsatisfactory".

Satisfactory: When the percent change in characteristic of the sample unit is equal to, or less than, or more than, as applicable, the percent change in characteristic of the standard.

Unsatisfactory: When the percent change in characteristic of the sample unit is greater than, or less than, as applicable, the percent change in characteristic of the standard.

METHOD 5804

6.4 No standard sample. When no standard sample has been established the change in the characteristic shall be reported as specified in the applicable test method or procurement document.

7* NOTES

7.1 A machine of the type described in this method may be obtained from Atlas Electric Devices Company, 4114 N. Ravenswood Avenue, Chicago, IL 60613.

METHOD 5830
July 20, 1978

LEACHING RESISTANCE OF CLOTH;
STANDARD METHOD

1. SCOPE

1.1 This method is intended for leaching cloth at room temperature. It is applicable for leaching materials which are to be subjected to the mildew resistance methods of group 5700.

2. TEST SPECIMEN

2.1 The specimen shall have the dimensions required for the subsequent evaluation test specified in the procurement document.

3. NUMBER OF DETERMINATIONS

3.1 The number of test specimens required from each sample unit shall be as specified in the subsequent evaluation test.

4. APPARATUS

4.1 Water container or tank of such a shape and size that the specimen can be submerged therein with all surfaces of the specimen having full access to the water, and a ratio of the specimen to water shall be not less than 1 to 100 by weight.

4.2 Means of supplying a continuous flow of water to the bottom of the container at a temperature of 80° to 85°F (27° to 29°C), and at a rate of about five changes per hour. Means shall also be provided at the container top for disposing of the overflow.

4.3 Means of suspending the specimens in such a manner that they do not contact the container or each other during leaching.

4.4 Means for completely submerging the specimen.

5. PROCEDURE

5.1 Unless otherwise specified in the procurement document, the specimen shall be submerged in the immersion tank containing water at a temperature of 80° to 85°F (27° to 29°C), and allowed to remain immersed for a period of 24 hours. At the end of the leaching period the specimen shall be removed from the water and air-dried unless otherwise indicated by the procurement document.

FED. TEST METHOD STD. NO. 191A

METHOD 5830

6. REPORT

6.1 The report shall be as provided for in the procurement document.

FED. TEST METHOD STD. NO. 191A

METHOD 5831
July 20, 1978

LEACHING RESISTANCE OF CLOTH;

MINIMUM EXPOSURE METHOD

1. SCOPE

1.1 This method is intended for leaching cloth at room temperature. It is applicable for leaching materials which are to be subjected to the mildew-resistance methods of group 5700. The leaching is not as severe as that described in Method 5830.

2. TEST SPECIMEN

2.1 The specimen shall have the dimensions required for the subsequent evaluation test specified in the procurement document.

3. NUMBER OF DETERMINATIONS

3.1 The number of test specimens required from each sample unit shall be as specified in the subsequent evaluation test.

4. APPARATUS

4.1 Water container or tank of such a shape and size that the specimen can be submerged therein with all surfaces of the specimen having full access to the water, and a ratio of the specimen to water shall be not less than 1 to 100 by weight.

4.2 Means of supplying a continuous flow of water to the bottom of the container at a temperature of 70° to 80°F (21° to 27°C), and at a rate of 6 changes per 24 hours. Means shall also be provided at the container top for disposing of the overflow.

4.3 Means of suspending the specimens in such a manner that they do not contact the container or each other during leaching.

4.4 Means for completely submerging the specimen.

5. PROCEDURE

5.1 Unless otherwise specified in the procurement document, the specimen shall be submerged in the immersion tank containing water at a temperature of 70° to 80°F (21° to 27°C), and allowed to remain immersed for a period of 24 hours. At the end of the leaching period the specimen shall be removed from the water and air-dried unless otherwise indicated by the procurement document.

METHOD 5831

6. REPORT

6.1 The report shall be as provided for in the procurement document.

FED. TEST METHOD STD. NO. 191A

METHOD 5832
July 20, 1978

LEACHING RESISTANCE OF CLOTH;

PREWET SPECIMEN METHOD

1. SCOPE

1.1 This method is intended for leaching materials which are difficult to wet-out at room temperature. It is applicable to materials such as impregnated fire, water, weather, and mildew-resistant fabrics.

2. TEST SPECIMEN

2.1 The specimen shall have the dimensions required for the subsequent evaluation test specified in the procurement document.

3. NUMBER OF DETERMINATIONS

3.1 The number of test specimens required from each sample unit shall be as specified in the subsequent evaluation test.

4. APPARATUS AND METHOD CITED

4.1 Apparatus.

4.1.1 Prewetting.

4.1.1.1 Container suitable for soaking the specimen.

4.1.1.2 Means of maintaining water at a temperature of 190° to 200°F (88° to 93°C).

4.1.2 Leaching.

4.1.2.1 Water container or tank of such a shape and size that the specimen can be submerged therein with all surfaces of the specimen having full access to the water. For cloth specimens the container shall allow not less than 1/2 gallon of water for each square foot (1.8 L/900 cm²) of specimen. The water shall be changed by a continuous flow or by emptying and refilling so that there shall be at least six complete changes of water in a 72-hour period.

4.1.2.2 Means of maintaining water at a temperature of 60° to 70°F (15° to 21°C), and a pH of 6.0 to 8.0 during the test.

4.1.2.3 Means for holding the specimen submerged throughout the leaching period.

FED. TEST METHOD STD. NO. 191A

METHOD 5832

4.2 Method cited.

Method 5830, Leaching Resistance of Cloth; Standard Method

5. PROCEDURE

5.1 Unless otherwise specified in the procurement document, the specimen shall be thoroughly wet-out by immersion with gentle agitation in water at a temperature of 190° to 200°F (88° to 93°C) for 30 seconds, then immersed in water at a temperature of 60° to 70°F (15° to 21°C) and a pH of 6.0 to 8.0 for 72 hours. The specimen shall then be removed and air-dried.

6. REPORT

6.1 The report shall be as provided for in the procurement document.

METHOD 5850
July 20, 1978

ACCELERATED AGEING OF CLOTH;

OVEN METHOD

1. SCOPE

1.1 This method is intended for determining the resistance of treated, coated, or laminated cloth and elastic cloth containing rubber or synthetic rubber to deterioration from exposure to heat in a circulating air oven.

2. TEST SPECIMEN

2.1 Unless otherwise specified in the procurement document, the specimen shall be a rectangle of cloth 4 by 6 Inches (102 by 152 mm) with the long dimension parallel to the direction of the warp.

3. NUMBER OF DETERMINATIONS

3.1 Unless otherwise specified in the procurement document, the number of specimens tested from each sample unit shall be as required in the method of test for determining the characteristic.

4. APPARATUS AND METHOD CITED

4.1 Apparatus.

4.1.1 Circulating air oven. Circulating air oven, thermostatically controlled and capable of maintaining the required temperature within $\pm 4^{\circ}\text{F}$ ($\pm 2^{\circ}\text{c}$).

4.2 Method cited.

Method 5100, Strength and Elongation, Breaking of Woven Cloth;
Grab Method.

5. PROCEDURE

5.1 Unless otherwise specified in the procurement document, the specimen shall be heated in the oven for 48 hours at a temperature of 212° to 221°F (100° to 105°c).

FED. TEST METHOD STD. NO. 191A

METHOD 5850

5.2 The specimen shall be placed openly in the circulating air oven by suspending vertically without touching another specimen or parts of the oven, and exposed for the required time at the required temperature. At the end of the exposure period the specimen shall be removed from the oven, cooled, and conditioned under standard atmospheric conditions as specified in Section 4 of this Standard, for not less than 16 and not more than 96 hours.

5.3 At the end of the conditioning period the breaking strength of the aged specimen if required, shall be determined as described in Method 5100. If other physical properties are required, the specimen shall be tested as described in the required method. The same physical tests shall be conducted on aged and unaged specimens for the purpose of comparison in determining the degree of deterioration of the aged material.

5.4 Other exposure conditions and subsequent evaluation tests which may be specified for a number of cloths are given in table 1.

TABLE I

Fabric	Temperature	Time period	Test after ageing for:
Impregnated fire-water-weather-resistant duck.	200° - 205°F (93° - 96°C)	5 days	Flexibility
Braided or knitted cloth with elastic strands.	158°F (70°C)	7 days	Elongation and permanent set.
Laminated cloth	212°F (100°C)	5 hours	Strength and delamination.
Mildew-treated cloth	212° - 221°F (100° - 105°C)	48 hours	Resistance to micro-organisms.

5.5 Calculation of results. The change in breaking strength or other characteristic shall be calculated as follows:

$$\text{Change in characteristic, percent} = \frac{O-E}{O} \times 100 \text{ or } \frac{E-O}{O} \times 100$$

Where: O = value before ageing.
E = value after ageing.

FED. TEST METHOD STD. NO. 191A

6. REPORT

6.1 The change in characteristic of the sample unit shall be the average of the results obtained from the specimens tested and shall be reported to the nearest 1.0 percent.

6.2 Each individual value used to calculate the average shall also be reported.

ACCELERATED AGEING OF CLOTH;

CLOSED CONTAINER METHOD

1. SCOPE

1.1 This method is intended for determining the resistance of treated, coated, or laminated cloth and elastic cloth containing rubber or synthetic rubber to deterioration from exposure to heat in an inclosed container.

2. TEST SPECIMEN

2.1 Unless otherwise specified in the procurement document, the specimen shall be a rectangle of cloth 4 by 6 inches (102 by 152 mm) with the long dimension parallel to the direction of the warp.

3. NUMBER OF DETERMINATIONS

3.1 Unless otherwise specified in the procurement document, the number of specimens tested from each sample unit shall be as required in the method of test for determining the characteristic.

4. APPARATUS AND METHODS CITED

4.1 Apparatus.

4.1.1 Circulating air oven. Circulating air oven, thermostatically controlled and capable of maintaining the required temperature within $\pm 4^{\circ}\text{F}$ ($\pm 2^{\circ}\text{C}$).

4.1.2 Quart (0.94 L) Mason jar.

4.2 Methods cited.

Method 5100, Strength and Elongation, Breaking of Woven Cloth;
Grab Method.

Method 5850, Accelerated Ageing of Cloth; Oven Method.

50 PROCEDURE

5.1 Unless otherwise specified in the procurement document, the specimen shall be exposed for 5 days at a temperature of $175^{\circ} \pm 4^{\circ}\text{F}$ ($79^{\circ} \pm 2^{\circ}\text{C}$).

METHOD 5851

5.2 The specimen shall be placed loosely inside a quart (0.94 L) Mason jar and conditioned in the open jar under standard atmospheric condition as specified in Section 4 of this Standard, for a minimum of 24 hours. At the end of the conditioning, the jar shall be closed airtight and placed in the oven for the required time at the required temperature. At the end of the exposure period the specimen shall be removed from the oven, cooled, and again conditioned.

5.3 At the end of the conditioning period, the breaking strength of the aged specimen if required shall be determined as described in Method 5100. If other physical properties are required, the specimen shall be tested as described in the required method. The same physical tests shall be conducted on aged and unaged specimens for the purpose of comparison in determining the degree of deterioration of the aged cloth.

5.4 Other exposure condition and subsequent evaluation tests which may be prescribed for a number of fabrics are given in table I, Method 5850.

5.5 Calculation of results.

5.5.1 The results shall be calculated as described in Method 5850.

6. REPORT

6.1 The report shall be as described in Method 5850.

ACCELERATED AGEING OF CLOTH;

OXYGEN METHOD

1. SCOPE

1.1 This method is intended for determining the resistance to deterioration of cloth composed in part of rubber or rubber like materials. It is applicable to coated cloth, rubberized yarn cloth, and cloth made elastic by use of rubber strands.

2. TEST SPECIMEN

2.1 Unless otherwise specified in the procurement document, the specimen shall be a rectangle of cloth 4 by 6 inches (102 by 152 E) with the longer dimension parallel to the direction of the warp.

3. NUMBER OF DETERMINATIONS

3.1 Unless otherwise specified in the procurement document, the number of specimens tested from each sample unit shall be as required in the method of test used for determining the characteristic.

4. APPARATUS AND METHOD CITED

4.1 Apparatus.

4.1.1 Oxygen pressure chamber. oxygen pressure ageing chamber consisting of a metal vessel, inside dimensions of which are at least 5 inches (127 mm) in diameter (or width) by 10 inches (254 mm) in height. It shall be capable of maintaining for at least 10 days an internal atmosphere of oxygen gas under a pressure of 300 pounds \pm 10 pounds per square inch (2050 \pm 50 kPa) and thermostatically controlled to maintain a temperature of 158° \pm 2°F (70° \pm 1°C) (see 7.1).

4.1.2 Means of indicating the temperature.

4.1.3 Means of indicating the pressure.

4.1.4 Temperature recorder.

4.1.5 Means for suspending the specimens vertically without touching each other or the sides of the chamber.

METHOD 5852

4.1.6 Oxygen under the required pressure.4.2 Method cited.

Method 5100, Strength and Elongation, Breaking of Woven Cloth; Grab Method.

5. PROCEDURE

5.1 Unless otherwise specified in the procurement document, the specimen shall be exposed for a period of 7 days at a temperature of 158° ±2°F (70° ±1°C).

5.2 The specimen shall be placed in the ageing chamber after it has been preheated to the operating temperature. The chamber shall be securely closed and the oxygen introduced into the chamber to a pressure of 300 pounds ±10 pounds per square inch (2050 ± 50 kpa). At least 10 ml of capacity shall be available in the chamber for each g of rubber compound or other oxidizable material.

5.3 At the termination of the ageing interval but before the chamber is opened the oxygen pressure shall be released slowly and uniformly requiring at least 5 minutes. The chamber shall then be opened and the specimen removed from the ageing chamber, laid out on a flat surface, and allowed to condition under standard atmospheric conditions as specified in Section 4 of this Standard, for not less than 16 hours nor more than 96 hours before physical testing.

5.4 At the end of the rest period, the breaking strength of the aged specimen if required shall be determined as described in Method 5100. If other physical properties are required, the specimen shall be tested as described in the required method. The same physical tests shall be conducted on aged and unaged specimens for the purpose of comparison in determining the degree of deterioration of the aged cloth.

5.5 Calculation of results. The change in breaking strength or other characteristic shall be calculated as follows:

$$\text{Change in characteristic, percent} = \frac{O-E}{O} \times 100 \text{ or } \frac{E-O}{O} \times 100$$

Where: O = value before ageing
E = value after ageing

6. REPORT

6.1 The change in characteristic of the sample unit shall be the average of the results obtained from the specimens tested and shall be reported to the nearest 1.0 percent.

METHOD 5852

6.2 Each individual valve used to calculate the average shall also be reported.

7. NOTES

7.1 An apparatus of the type described in this method may be obtained from the Emerson Apparatus Co., 171 Tremont street, Melrose, MA 02176.

TEMPERATURE, HIGH; EFFECT ON CLOTH FLEXIBILITY

1. SCOPE

1.1 This method is intended for determining the effect of high temperature on the flexibility of cloth.

2. TEST SPECIMEN

2.1 The specimen shall have the dimensions required for the stiffness evaluation test.

3. NUMBER OF DETERMINATIONS

3.1 Unless otherwise specified in the procurement document, a minimum of three specimens tested from each sample unit shall be as required for the stiffness test for determining stiffness.

4. APPARATUS AND METHODS CITED

4.1 Apparatus.

4.1.1 Circulating air oven. Circulating air oven capable of maintaining the required temperature within $\pm 5^{\circ}\text{F}$ ($\pm 3^{\circ}\text{C}$).

4.2 Methods cited.

Method 5200, Stiffness of Cloth, Directional;
Method

Method 5202, Stiffness of Cloth, Directional;
Method

Method 5204, Stiffness of Cloth, Directional;
Cantilever Method

5. PROCEDURE

5.1 The stiffness of the specimen shall be determined by Method 5200 or 5204, as specified in the procurement document.

5.2 The specimen shall be placed in the oven at a temperature of $(104^{\circ} \pm 3^{\circ}\text{C})$ for 5 hours. Care shall be taken to prevent damage to the specimen while in the oven.

METHOD 5870

5.3 The specimen shall then be withdrawn, cooled, and brought to standard atmospheric conditions as specified in Section 4 of this Standard, and the stiffness again determined by the method used in determining the stiffness before heating.

5.4 Care shall be taken in mounting the specimen for the initial and after-heating stiffness tests that the specimen is positioned exactly the same in regard to the bending direction (inside or outside, warp or filling) of the cloth. When necessary for identification, one side of the specimen shall be marked.

5.5 Calculation of result: The change in stiffness shall be calculated as follows :

$$\text{Change in stiffness, percent} = \frac{O - E}{O} \times 100 \text{ or } \frac{E - O}{O} \times 100$$

Where O=valve before heating
E= valve after heating

6. REPORT

6.1 The change in stiffness of the sample unit shall be the average of the results obtained in each of the directions from the specimens tested and shall be reported to the nearest 1.0 percent.

6.2 Each individual value used to calculate the average shall also be reported.

METHOD 5872
July 20, 1978

TEMPERATURE , HIGH; EFFECT ON CLOTH BLOCKING

1. SCOPE

1.1 This method is intended for determining the resistance of films and coated cloth to blocking.

2. TEST SPECIMEN

2.1 The specimen shall be a square of cloth 8 by 8 inches (203 by 203 mm).

3. NUMBER OF DETERMINATIONS

3.1 Unless otherwise specified in the procurement document, three specimens shall be tested from each sample unit.

4. APPARATUS

4.1 Glass plates. Two glass plates approximately 4-1/2 by 4-1/2 by 1/8 inches (114 by 114 by 3 mm).

4.2 Four-pound weight (1.8 kg).

4.3 Circulating air oven. Circulating air oven capable of maintaining the required temperature within $\pm 2^{\circ}\text{F}$ ($\pm 1^{\circ}\text{C}$).

5. PROCEDURE

5.1 The specimen shall be folded double, face to face, then back to back, making a 4 by 4 inch (102 by 102 mm) square, and placed between the two glass plates. The 4-pound (1.8 kg) weight shall be placed on the top plate in a position to insure even pressure.

5.2 Unless otherwise specified in the procurement document, the specimen shall be placed in the oven for 30 minutes at a temperature of $180^{\circ} \pm 2^{\circ}\text{F}$ ($82^{\circ} \pm 1^{\circ}\text{C}$).

5.3 At the end of the exposure period the test assembly shall be removed from the oven and the specimen immediately taken from between the plates and allowed to cool (1 hour for films and 5 minutes for coated fabrics). The specimen shall then be slowly unfolded and, at the same time, carefully examined for evidence of adhering or peeling of the coating.

FED. TEST.METHOD STD. No. 191A

METHOD 5872

5.4 The resistance of the specimen to blocking shall be evaluated by the Scale below:

- (1) No blocking: Cloth surfaces are free.
- (2) No blocking: Cloth surfaces adhere slightly.
- (3) Slight blocking: Cloth surfaces must be lightly peeled to separate.
- (4) Blocking: Cloth surfaces separate with difficulty, or coating is removed during separation.

6. REPORT

6.1 Resistance to blocking shall be reported as rated In 5.4.

METHOD 5874
July 20, 1978

TEMPERATURE , LOW ; EFFECT ON COATED CLOTH

1. SCOPE

1.1 This method is intended for determining the resistance of coated cloth to low temperature.

2. TEST SPECIMEN

2.1 The specimen shall be a square of cloth not less than 8 by 8 inches (203 by 203 mm).

3. NUMBER OF DETERMINATIONS

3.1 Unless otherwise specified in the procurement document, three specimens shall be tested from each sample unit.

4. APPARATUS AND METHOD CITED

4.1 Apparatus.

4.1.1 Cold chamber capable of maintaining the required temperature within ($\pm 2^{\circ}\text{C}$) for the required time.

4.1.2 Steel roller, approximately 5-1/2 inches (140 mm) in diameter, approximately 2 inches (51 mm) wide, with a suitable handle guide. Unless otherwise specified in the procurement document, the total weight shall be 10 pounds (4.5 kg).

4.1.3 Pair of gloves.

4.2 Method cited.

Method 5516, Water Resistance of cloth; Water Permeability, Hydrostatic Pressure Method.

5. PROCEDURE

5.1 Unless otherwise specified in the procurement document, the specimen shall be exposed at a temperature of $20^{\circ} \pm 2^{\circ}\text{F}$ ($-7^{\circ} \pm 1^{\circ}\text{C}$) for 30 minutes.

METEOD 5874

5.2 The specimen shall be exposed in the cold chamber to the required temperature for the required period of time. Without being removed from the specified temperature conditions, the specimen shall be creased 180° in the center in the warp and filling directions respectively by folding slightly while lying on a flat smooth surface and running the center of the steel roller over the fold a single time. The specimen shall be opened between the two creasing operations. The pressure on the specimen shall be the weight of the roller. The temperature of the roller shall be the same as that of the specimen. The specimen shall be handled with gloves and care taken that its temperature remains uniform throughout the test. The cloth shall be so folded, in both warpwise and fillingwise directions, that the coating in case of single coated cloth, or the heavier coating in case of unbalanced double coating, shall be on the outside of the fold. In the case of a true balance double coating, either side may be toward the outside of the fold.

5.3 The specimen shall be visually examined for signs of cracking or flaking.

5.4 The specimen shall then be brought to standard atmospheric conditions as specified in Section 4 of this Standard and its hydrostatic resistance then measured as described in Method 5516.

5.5 A specimen of the unexposed cloth shall be creased as above, visually examined for signs of cracking and flaking, and then its hydrostatic resistance measured as described in Method 5516.

5.6 Calculation of results. The resistance to low temperatures shall be expressed as the change in hydrostatic resistance and shall be calculated as follows:

$$\text{Change in hydrostatic resistance, percent} = \frac{O-E}{O} \times 100 \text{ or } \frac{E-O}{O} \times 100$$

Where:

O = value of unexposed cloth.

E = value of EXPOSED CLOTH.

6. REPORT

6.1 Any indication of cracking or flaking of the exposed and unexposed specimens shall be reported.

METHOD 5874

6.2 The loss in hydrostatic resistance of the sample unit shall be the average of the results obtained from the specimens tested and shall be reported to the nearest 1.0 percent.

6.3 Each individual value used to calculate the average shall also be reported.

METHOD 5900
July 20, 1978

FLAME RESISTANCE OF CLOTH; HORIZONTAL

1. SCOPE

1.1 This method is intended for use in determining the resistance of cloth to burning. It is applicable to flameproofed and fire-resistant fabrics and to some untreated fabrics with very open weave, such as coarse netting.

2. TEST SPECIMEN

2.1 The specimen shall be a rectangle of cloth 7 inches by 10 inches (178 mm by 254 mm), with the long dimension parallel to either the warp or filling direction.

3. NUMBER OF DETERMINATIONS

3.1 Unless otherwise specified in the procurement document, one specimen from each of the warp and filling directions shall be tested from each sample unit.

4. APPARATUS

4.1 Hood or cabinet. Hood, cabinet, or other convenient enclosure which will protect the specimen and ignition flame from drafts.

4.2 Specimen holder. Specimen holder consisting of a metal rectangular frame with an inside diameter 6 inches by 9 inches (152 mm by 229 mm), and mounted on four metal legs, one at each corner. The upper side of the metal frame shall have metal pegs for fastening the specimen in a taut position. The pegs shall be spaced approximately 1 inch (25 mm) apart except for those in the center which shall be 2 inches (51 mm) apart.

4.3 Ignition flame. A vertical flame for igniting the specimen shall be provided by burning 0.3 ml of anhydrous ethyl alcohol (absolute) in a round flat-bottom brass cup. The cup shall be made from brass 1/32 inch (0.5 mm) in thickness. The dimension of the cut shall be 11/16 inch (17 mm) outside diameter and 9/32 inch (7 mm) in over-all height. The cup shall be mounted on a material of low heat conductivity such as cork and in such a manner that the center of the cup shall be directly beneath the center of the specimen with a distance of 3 inches (76 mm) from the lip of the cup to the specimen.

4.4 Means, such as an electric spark, of igniting alcohol in the brass cup.

METHOD 5900

4.5 Pipette graduated in 0.1 ml.

4.6 Measuring scale. Metal scale graduated in increments of 1/16 inch (1 mm) for measuring the diameter of the hole burned in the specimen.

4.7 Circulating air oven. A circulating air oven capable of maintaining the required temperature within $\pm 2^{\circ}\text{F}$ ($\pm 1^{\circ}\text{C}$).

5. PROCEDURE

5.1 The specimen shall be suspended and heated in a circulating at a temperature of 140° to $145^{\circ}\text{F} \pm 2^{\circ}\text{F}$ (60 to $63^{\circ}\text{C} \pm 1^{\circ}\text{C}$) for $4 \pm \frac{1}{4}$ before testing. Only one specimen shall be removed from the oven at a time and immediately subjected to the test.

5.2 The test shall be conducted in a hood or enclosed space free from drafts. The specimen shall be mounted in the holder in a taut position, 0.3 ml of alcohol shall be placed in the cup, the cup immediately placed in position, and the alcohol ignited as quickly as possible. The specimen shall remain in the test position in the draft-free enclosure until all the alcohol has burned, the afterglow of the specimen has stopped, and the burned hole has been measured.

5.3 The charred area of the specimen shall be removed by running a wooden pencil or similar object around the inside of the hole. The greatest distance across the hole shall be measured to the nearest 1/16 inch (1 mm).

5.4 When repeated determinations are conducted, the air in the hood or enclosure shall be changed and sufficient time permitted for the cup to cool to room temperature after each determination.

6. REPORT

6.1 The flame resistance of the sample unit shall be the average of the results obtained from the specimens tested and shall be reported to the nearest 1/16 inch (1 mm).

METHOD 5903
July 20, 1978

FLAME RESISTANCE OF CLOTH; VERTICAL

1. SCOPE

1.1 This method is intended for use in determining the resistance of cloth to flame and glow propagation and tendency to char. It is designated primarily for cellulosic fabrics treated with a flame retardant, but may be utilized in other applications as specified in applicable procurement documents. In addition to the vertical position of the sample and flame exposure conditions common to tests of this type, the method defines gas composition, burner, cabinet, temperature and humidity test conditions since it is designed primarily for interlaboratory testing of the same material.

2. TEST SPECIMEN

2.1 The specimen shall be a rectangle of cloth 2-3/4 inches (70 mm) by 12 inches (305 mm) with the long dimension parallel to either the warp or filling direction of the cloth. No two warp specimens shall contain the same warp yarns, and no two filling specimens shall contain the same filling yarns.

3. NUMBER OF DETERMINATIONS

3.1 Unless otherwise specified in the procurement document, five specimens from each of the warp and filling directions shall be tested from each sample unit.

4. APPARATUS

4.1 Cabinet. A cabinet and accessories, fabricated in accordance with the requirements specified in figures 5903A, B, and C. Galvanized sheet metal or other suitable metal shall be used. The entire inside back wall of the cabinet shall be painted black to facilitate the viewing of the test specimen and pilot flame (see 7.1.2).

4.2 Burner. The burner shall be equipped with a variable orifice to adjust the flame height, a barrel having a 3/8 inch (10 mm) inside diameter and a pilot light.

4.2.1 The burner may be constructed by combining a 3/8 inch (10 mm) inside diameter barrel $3 \pm 1/4$ inches (76 ± 6 mm) long from a fixed orifice burner with a base from a variable orifice burner.

FED. TEST METHOD STD. NO. 191A

METHOD 5903

4.2.2 The pilot light tube shall have a diameter of approximately 1/16 inch (2 mm) and shall be spaced 1/8 inch (3 mm) away from the burner edge with a pilot flame 1/8 inch (3 mm) long.

4.2.3 The necessary gas connections and the applicable plumbing shall be as specified in Figure 5903D except that a solenoid valve may be used in lieu of the stopcock valve to which the burner is attached. The stopcock valve or solenoid valve, whichever is used, shall be capable of being fully opened or fully closed in 0.1 second.

4.2.4 On the side of the barrel of the burner, opposite the pilot light there shall be a metal rod of approximately 1/8 inch (3 mm) diameter spaced 1/2 inch (13 mm) from the barrel and extending above the burner. The rod shall have two 5/16 inch (8 mm) prongs marking the distances of 3/4 inch (19 mm) and 1 1/2 inch (38 mm) above the top of the burner,

4.2.5 The burner shall be fixed in a position so that the center of the barrel of the burner is directly below the center of the specimen.

4.3 Gas regulator valve system. A control valve system with a delivery rate designed to furnish gas to the burner under a pressure of 2-1/2 ± 1/4 pounds per square inch (17.2 kPa ± 1.7 kPa) at the burner inlet. The manufacturer's recommended delivery rate for the valve system shall include the required pressure (see 7.1.1).

4.4 Gas mixture. A synthetic gas mixture of the following composition within the following limits (analyzed at standard conditions): 55 ± 3 percent hydrogen, 24 ± 1 percent methane, 3 ± 1 percent ethane, and 18 ± 1 percent carbon monoxide, which will give a specific gravity of 0.365 + 0.018 (air = 1) and a B.T.U. content of 540 ± 20 btu's per cubic foot (dry basis)-at 70°F (21°C) (see 7.1.1).

4.5 Metal hooks and-weights. Metal hooks and weights to produce a series of total loads to determine length of char. The metal hooks shall consist of No. 19 gage steel wire or equivalent and shall be made from 3 inch (76 mm) lengths of the wire and bent 1/2 inch (13 mm) from one end to a 45 degree hook. One end of the hook shall be fastened around the neck of the weight to be used.

4.6 Stop watch. Stop watch or other device to measure the burning time to 0.2 second.

4.7 Measuring scale. Measuring scale or metal tape graduated in increments of 1/8 inch (1 mm) to measure the length of char.

METHOD 5903

5. PROCEDURE

5.1 The material undergoing test shall be evaluated for the characteristics specified in the applicable procurement document, i.e. after-flame time, after-glow time and char length on each specimen as applicable.

5.2 All specimens to be tested shall be at moisture equilibrium under standard atmospheric conditions in accordance with Section 4 of this Standard. Each specimen to be tested shall be exposed to the test flame within 20 seconds after removal from the standard atmosphere.

5.2.1 In case of dispute all testing will be conducted under Standard Atmospheric Conditions in accordance with Section 4 of this Standard.

5.3 The specimen in its holder shall be suspended vertically in the cabinet in such a manner that the entire length of the specimen is exposed and the lower end is 3/4 inch (19 mm) above the top of the gas burner. The apparatus shall be set up in a draft free area.

5.4 Prior to inserting the specimen, the pilot flame shall be adjusted to approximately 1/8 inch (3 mm) in height measured from its lowest point to the tip. The burner flame shall be adjusted by means of the needle valve in the base of the burner to give a flame height of 1-1/2 inches (38 mm) with the stopcock fully open and the air supply to the burner shut off and taped. The 1-1/2 inch (38 mm) flame height is obtained by adjusting the valve so that the uppermost portion (tip) of the flame is level with the tip of the metal prong (see Figure 5903B) specified for adjustment of flame height. It is an important aspect of the evaluation that the flame height be adjusted with the tip of the flame level with the tip of the metal prong. After inserting the specimen, the stopcock shall be fully opened, and the burner flame applied vertically at the middle of the lower edge of the specimen for 12 seconds and the burner turned off. The cabinet door shall remain shut during testing.

5.5 The after-flame time shall be the time the specimen continues to flame after the burner flame is shut off.

5.6 The after-glow time shall be the time the specimen continues to glow after it has ceased to flame. If the specimen glows more than 30 seconds, the specimen holder containing the specimen shall be removed from the test cabinet without any unnecessary rate of movement of the specimen which will fan the glow, and suspended in a draft-free area in the same vertical position as in the test cabinet. When more than one glowing specimen is suspended outside the test apparatus, the specimens shall be spaced at least 6 inches (152 mm) apart. The specimens shall remain stationary until all glowing has ceased. The glow shall not be extinguished even when the after-glow time is not being determined.

METHOD 5903

5.7 After each specimen is removed, the test cabinet shall be cleared of fumes and smoke prior to testing the next specimen.

5.8 After both flaming and glowing have ceased, the char length shall be measured. The char length shall be the distance from the end of the specimen, which was exposed to the flame, to the end of a tear (made lengthwise) of the specimen through the center of the charred area as follows: The specimen shall be folded lengthwise and creased by hand along a line through the highest peak of the charred area. The hook shall be inserted in the specimen (or a hole, 1/4 inch (6 mm) diameter or less, punched out for the hook) at one side of the charred area 1/4 inch (6 mm) from the adjacent outside edge and 1/4 inch (6 mm) in from the lower end. A weight of sufficient size such that the weight and hook together shall equal the total tearing load required in 5.9.1 shall be attached to the hook.

5.9 A tearing force shall be applied gently to the specimen by grasping the corner of the cloth at the opposite edge of the char from the load and raising the specimen and weight clear of the supporting surface. The end of the tear shall be marked off on the edge and the char length measurement made along the undamaged edge.

5.9.1 Loads for determining char length. The specific load applicable to the weight of the test cloth shall be as follows:

<u>Specified weight per square yard of cloth before any fire retardent treatment or coating</u>		<u>Total tearing weight for determining the charred length</u>	
<u>Ounces per square yard</u>	<u>g/m²</u>	<u>Pounds</u>	<u>kg</u>
2.0 to 6.0	68 to 203	0.25	0.1
Over 6.0 to 15.0	Over 203 to 508	0.5	0.2
Over 15.0 to 23.0	Over 508 to 780	0.75	0.3
Over 23.0	Over 780	1.0	0.45

5.10 The after-flame time and after-glow time of the specimen shall be recorded to the nearest 0.2 second and the char length to the nearest 1/8 inch (1 mm).

6. REPORT

6.1 The after-flame time, after-glow time and char length of the sample unit shall be the average of the results obtained from the individual specimens tested. All values obtained from the individual specimens shall be recorded.

6.2 The after-flame time and after-glow time shall be reported to the nearest 0.2 second and the char length to the nearest 1/8 inch (1 mm).

7. NOTES

7.1 Suggested sources of materials and equipment.

7.1.1 Gas mixture (4.4) and regulator valve system (4.3) are available from:

- (a) Matheson Gas Products
P.O. BOX 85
East Rutherford, NJ 07073
- (b) Air Products and Chemicals, Inc.
P.O. BOX 538
Allentown, PA 18105

7.1.2 Test cabinet (4.1) is available from:

- (a) U.S. Testing Company
1941 Park Avenue
Hoboken, NJ 07030
- (b) The Govmark Organization, Inc.
P.O. BOX 807
Bellmore, NY 11710

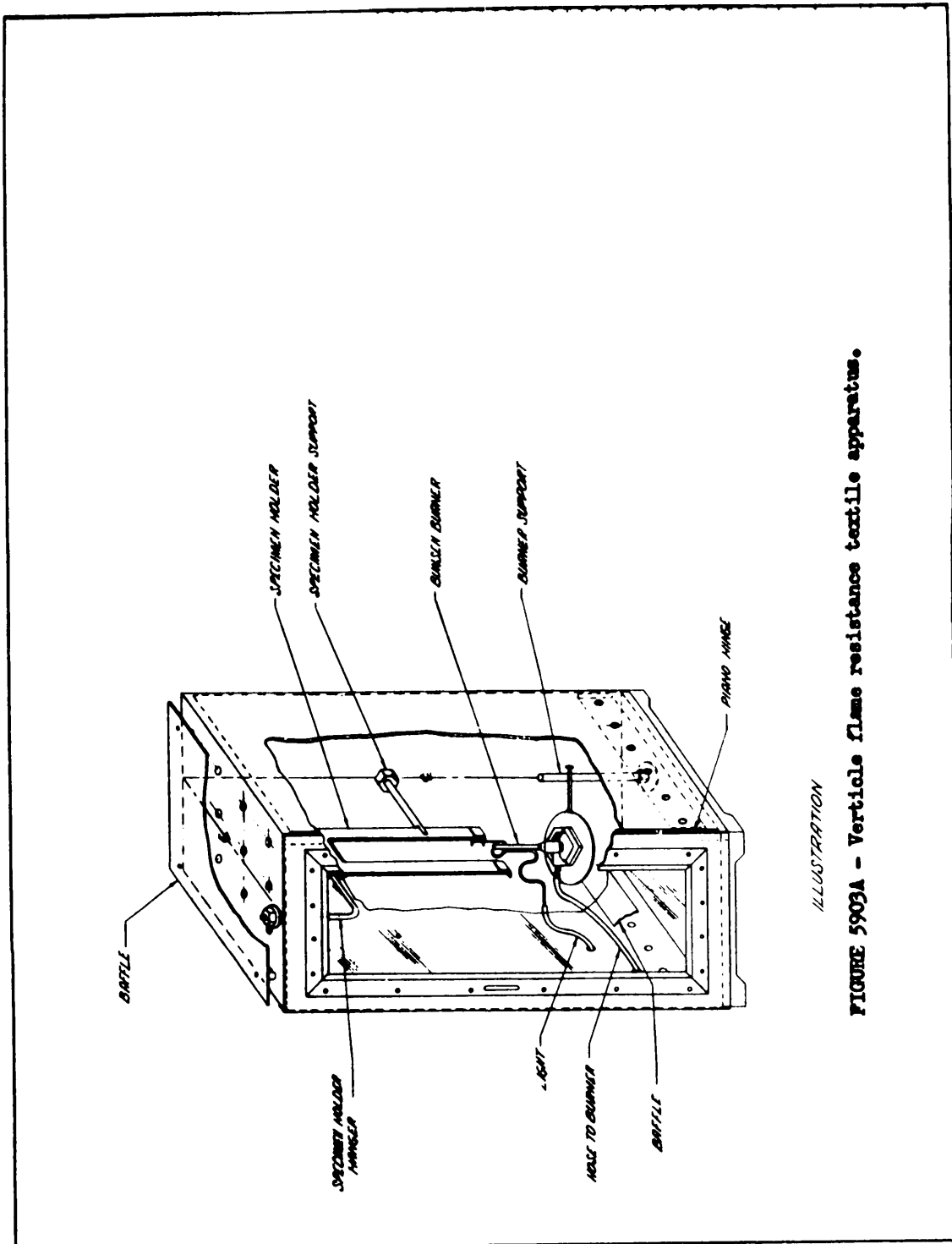

ILLUSTRATION

FIGURE 5903A - Vertical flame resistance textile apparatus.

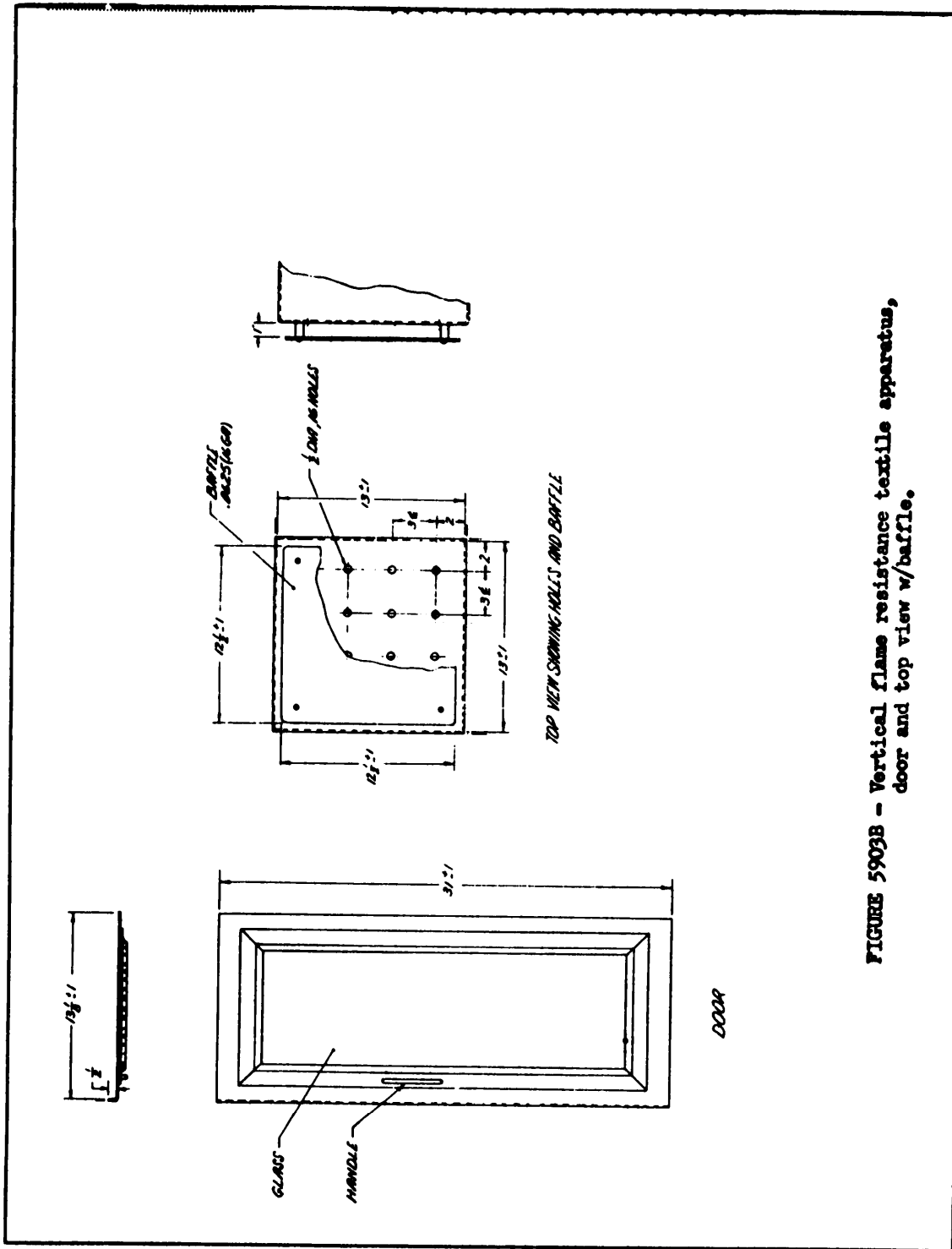

FIGURE 5903B - Vertical flame resistance textile apparatus, door and top view w/baffle.

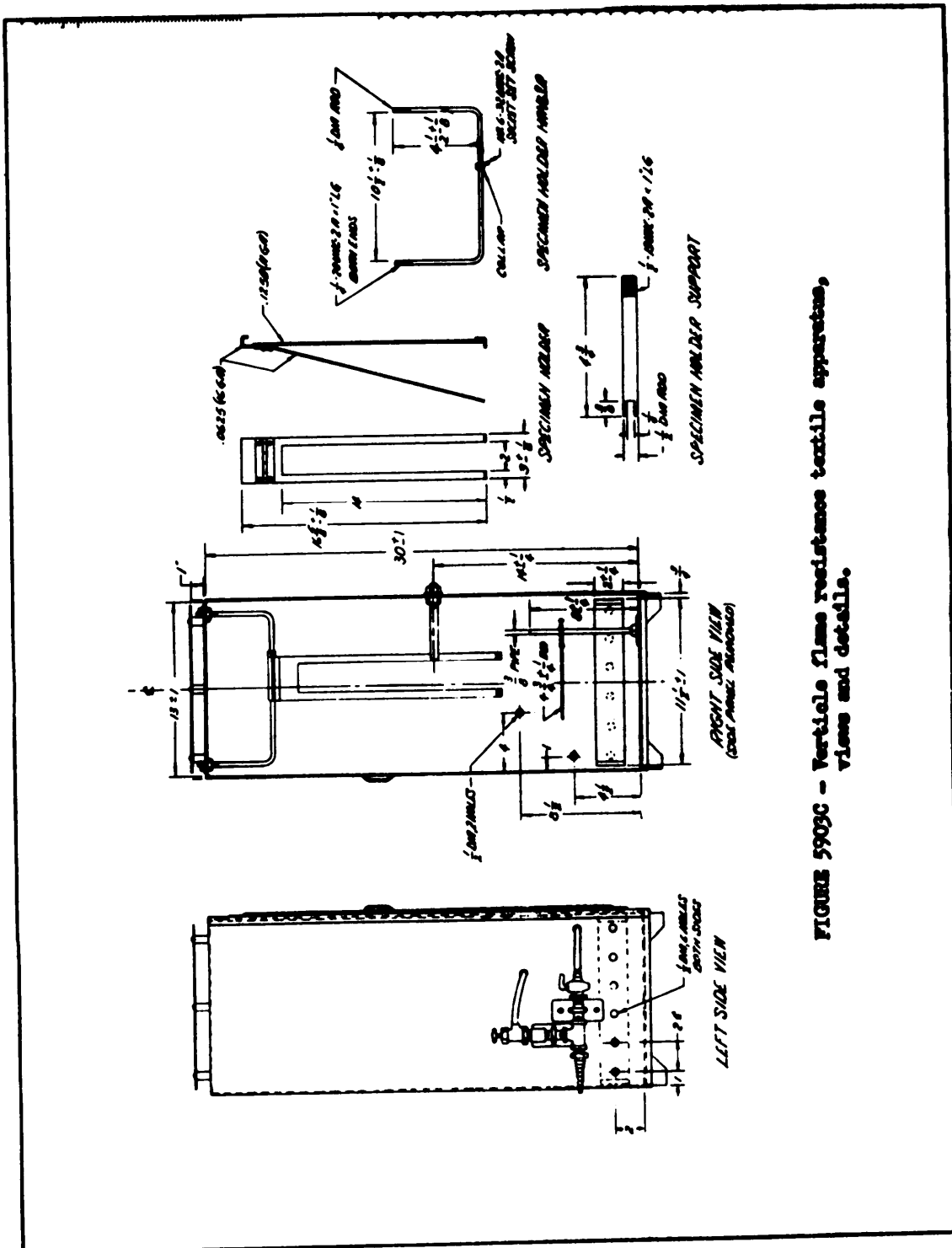

FIGURE 5903C - Vertical flame resistance textile apparatus, views and details.

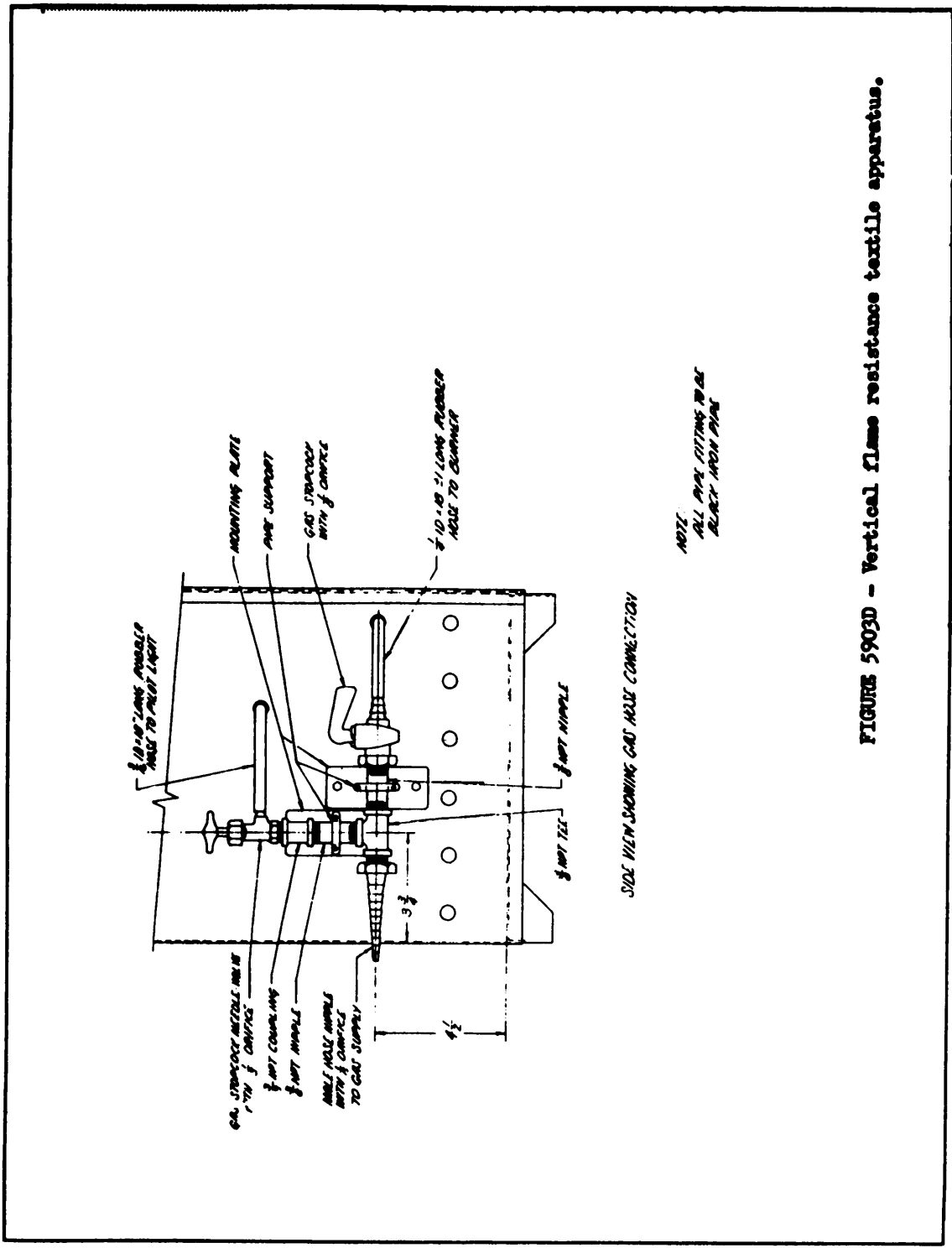

FIGURE 5903D - Vertical flame resistance textile apparatus.

METHOD 5904
July 20, 1978

FLAME RESISTANCE OF CLOTH; VERTICAL, FIELD

1. SCOPE

1.1 This method is intended for use in the field for determining the resistance of cloth other than pile fabrics to burning. It gives results which are comparable to those of the vertical flame resisting test, Method 5902. The test may be applied to any horizontal edge or split in the cloth (or any edge which can be placed in a horizontal position for testing) without the necessity of cutting out specimens or, in general, without removing the cloth from its position. The test is considered too severe for cloth that has not been flame-proofed or is not fire-resistant.

2. TEST SPECIMEN

2.1 The specimen shall be a piece of cloth of any size which contains an edge which can be placed in a horizontal position for testing.

3. NUMBER OF DETERMINATIONS

3.1 Unless otherwise specified in the procurement document, three specimens shall be tested from each sample unit.

4. APPARATUS (See fig. 5904)

4.1 Specimen holder. Specimen holder consisting of a clamp made from duplicate rectangular pieces of sheet metal 1/16 inch (1 mm) in thickness and not less than 6 inches (152 mm) wide and 7 inches (178 mm) long. An area 2 inches (51 mm) wide and 5 inches (127 mm) deep shall be cut from the center of one end of the rectangular pieces of metal leaving two U-shaped plates. The two plates shall be clamped together at the ends of the U-prongs by means of spring-type paper clips 1-1/4 inches (32 mm) wide.

4.2 Candle. Paraffin candle 3/4 inch (19 mm) in diameter shall be used as the source of ignition. The candle shall be mounted in a holder hinged to one side of the clamp in such a manner that the candle can be swung away from the specimen for adjustment and, when used for ignition, can be swung against a stop so that the center of the candle shall be directly under the 2-inch (51 mm) wide exposed lower edge of the specimen.

4.3 Timing device. Stop watch or other timing device which will indicate the burning time to 1/5 second.

4.4 Measuring scale. Metal scale graduated in increments of 0.1 inch (1 mm) for measuring char length of the specimen.

FED. TEST METHOD STD. NO. 191A

METHOD 5904

5. PROCEDURE

5.1 The holder shall be held with the U in an inverted position. The specimen shall be slipped between the two plates of the clamp until the horizontal edge of the cloth is even with the ends of the U-prongs, which are held together by means of paper clips. Thus an area of cloth 2 inches by 5 inches (51 mm by 127 mm) shall be exposed, held in a vertical position, and firmly clamped in a metal shield which prevents the flame from extending beyond the exposed area.

5.2 The tapered portion of the candle shall be allowed to burn until a normal constant flame is obtained. The candle shall be adjusted so that the center of the candle is directly under the middle of the 2-inch (51 mm) exposed lower edge of the specimen and midway between the U-prongs of the holder. At the completion of the adjustment the top of the wick shall be 1/8 inch (1 mm) below the edge of the specimen. The flame shall be applied to the edge of the specimen for 12 seconds and withdrawn. The clamp shall not be removed from the specimen until all flame and glow have ceased.

5.3 The flaming time shall be the time the material continues to flame after removal of the candle flame from the specimen.

5.4 Char length shall be the distance from the edge of the specimen to the end of a tear through the charred area, made by hand with enough force to tear through the charred or scorched portion but not of sufficient force to break undamaged yams.

6. REPORT

6.1 The flaming time and char length of the sample unit shall be the average of the results obtained from the specimens tested.

6.2 The flaming time of the sample unit shall be reported to the nearest 1/5 second and the char length to the nearest 0.1 inch (1 mm).

6.3 Each individual value used to calculate the average shall also be reported.

VERTICAL FIELD TEST

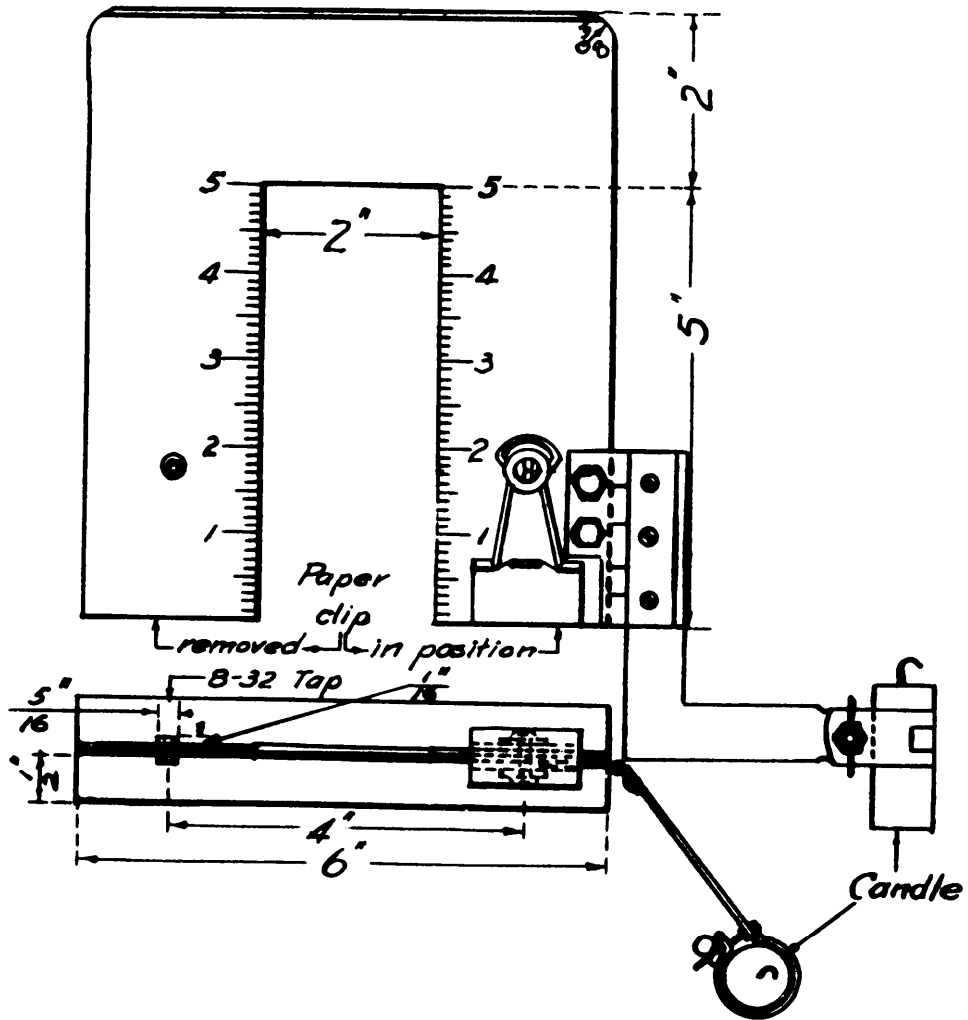

FIGURE 5904

METHOD 5905
July 20, 1978

FLAME RESISTANCE OF MATERIAL; HIGH HEAT

FLUX FLAME CONTACT

1. SCOPE

1.1 This method is intended for use in determining the resistance of textiles and other materials to flame propagation.

1.2 It also provides a means to identify changes that occur in thermoplastic materials on flame contact such as melting or shrinking from the flame source and is useful in predicting the flame resistance of materials which are not ignited by a low heat flux ignition source but from flammable decomposition products when subjected to a higher heat flux.

1.3 This method is intended to complement Method 5903 and provides a higher heat flux flame contact and a longer exposure time to flame source. The heat flux is comparable to that of the ignition source (6 lbs. (2.7 kg) of paper set within a 3-foot (914 mm) length) used in a tent burning test.

2. TEST SPECIMEN

2.1 The specimen shall be a rectangle of material 2-3/4 inches by 12 inches (70 mm by 305 mm) with the long dimension parallel to either the warp or filling direction of the cloth. For woven materials no two specimens shall contain the same warp and filling yarns.

3. NUMBER OF DETERMINATIONS

3.1 Unless otherwise specified in the procurement document, five specimens from each of the warp and filling directions shall be tested from each sample

4. APPARATUS

4.1 Burner. Fisher burner, high temperature, liquefied petroleum

4.2 Crucible tongs.

4.3 Support stand.

4.4 Utility clamp.

4.5 Stop watch. Stop watch' or other device to measure second.

FED. TEST METHOD STD. NO. 191A

METHOD 5905

4.6 Butane gas C.P. (see 7.1.1).

4.7 Gas regulator valve system. A control valve system with a delivery rate designed to furnish gas to the burner under a pressure of $2\frac{1}{2} + \frac{1}{4}$ lbs. per square inch (175 ± 17.5 g/cm²) at the reducing valve. The flame height is adjusted at the reducing valve producing a pressure at the burner of about 0.1 lbs per square inch (45 g/cm²) (see 7.1.1).

4.8 Measuring scale. Measuring scale or metal tape graduated in increments of 1/8 inch (1 mm) to measure the length of char.

5. PROCEDURE

5.1 The material undergoing test shall be evaluated for characteristics specified in the applicable procurement document, i.e., ignition resistant, self-extinguishing, after-flame time, non-melting, does not drop flaming pieces from the material, non-shrinking and percent consumed.

5.2 All specimens tested shall be at moisture equilibrium under Standard Atmospheric Conditions in accordance with Section 4 of this Standard.

5.3 The ignition source is a high-temperature burner with butane gas fed through the control valve system. Adjust the air inlet valve of the burner to half open. Open the burner needle valve approximately 1/2 turn from the closed position. Turn on the gas. Adjust the total flame height to approximately 3 inches (76 mm) using a ruler or a metal spur attached to the burner to estimate the flame height.

5.4 Grasp the top edge of the specimen with the crucible tongs and suspend it vertically in the flame for 12 seconds. The specimen is held with the lower edge 1-1/2 inches (38 mm) above the center of the burner. If the specimen shrinks or changes in shape, it shall be moved so that the lowest part of the specimen is in the required position. At the end of the 12 second period, withdraw the specimen slowly. Time any after-flaming that occurs (see Figure 5905A). When any flaming has ceased, reintroduce the specimen into the flame for 12 seconds, withdraw it slowly and again time any after-flame.

5.5 For specimen which may block the burner flame with melt, the burner, after adjusting the flame as described in 5.3, is clamped to a stand in a horizontal position six inches (152 mm) above the stand base. The specimen is introduced into the flame in a vertical position and the test is carried out as described in 5.4.

5.6 Definitions.

5.6.1 Ignites, propagates flame. The test specimen ignites and is completely consumed by flame either during flame contact or after withdrawal from the burner; or, flaming melt from the test specimen propagates flame, i.e., melt flames as it leaves the test specimen.

METHOD 5905

5.6.2 Ignites self-extinguishing. The test specimen flames during or after withdrawal from flame exposure but is self-extinguishing before the entire length of the specimen is consumed.

5.6.3 Ignition resistant. No flaming of the specimen occurs during exposure or after withdrawal from the flame source (see Figure 5905B).

5.6.4 Melts. The portion of the specimen in contact with the flame turns to a viscous liquid and flows, separating from the specimen.

5.6.5 Shrinks. The specimen in contact with the flame withdraws from it by shrinking, or breaking up without forming a liquid melt (see Figure 5905C).

5.6.6 Drops flaming pieces. A part of the specimen breaks away or melts away from the specimen and is flaming as it leaves the specimen (see Figure 5905D).

5.7 Calculations.

$$\text{Percent consumed} = \frac{L - A}{L} \times 100$$

Where: L = original length of specimen.

A = length of uncharred part of specimen from the top of the specimen down the side with less charred area to the point at which the uncharred area first reaches a width of less than one inch (25 mm).

5.7.1 To obtain the length of the uncharred portion, measure the uncharred length from the top of the specimen down the side of the specimen to the point at which the uncharred area first reaches a width of less than one inch (25 mm) from a side of the specimen.

5.7.2 Measure this length of the uncharred portion to the nearest 1/4 inch (1 mm).

6. REPORT

6.1 Report the test results for each 12 second exposure as follows:

The material: (a) ignites, propagates flame
(b) ignites but is self-extinguishing
(c) is ignition resistant
(d) melts
(e) shrinks away from the flame
(f) drops flaming pieces.

METHOD 5905

6.2 The after-flame of the sample unit shall be the average of the results obtained of the individual specimens tested and shall be reported to the nearest 1.0 second.

6.2.1 Report the after-flame for each 12 second exposure.

6.3 For materials which melt or shrink away from the flame, report the after-flame only.

6.4 The percent consumed of the sample unit shall be the average of the individual specimens tested and shall be reported to the nearest 1.0 percent (5.7). The percent consumed shall be measured only after the second exposure.

6.5 The individual results utilized in obtaining the average shall also be reported.

7. NOTES

7.1 Suggested sources of materials and equipment.

7.1.1 Gas mixture (4.6) and regulator valve system (4.7) are available from:

(a) Matheson Gas Products
P.O. BOX 85
East Rutherford, NJ 07073

(b) Air Products and Chemicals, Inc.
P.O. BOX 538
Allentown, PA 18105

7.1.2 Burner described in 4.1 is available from:

(a) Fisher Scientific Company
711 Forbes Avenue
Pittsburgh, PA 15219



5905A

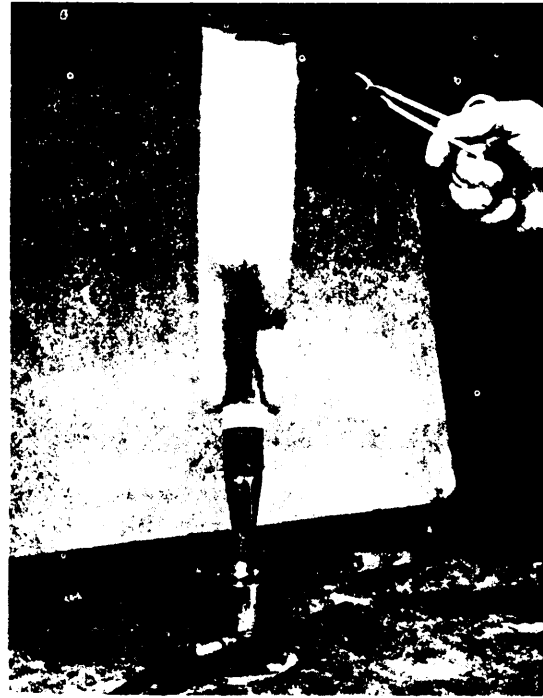

5905B



5905C



5905D

FIGURE 5905 Flame Contact Test

METHOD 5906
July 20, 1978

FLAMMABILITY, BURNING RATE OF CLOTH; HORIZONTAL

1. SCOPE

1.1 This method is intended for use in determining the comparative rates of burning of cloth. This method is satisfactory for cloth that has not been flameproofed, including pile and napped cloth. The rate of burning is slower in this method than in Method 5902.

2. TEST SPECIMEN

2.1 Unless otherwise specified in the procurement document, the specimen shall be a rectangle of cloth 4-1/2 inches by 12-1/2 inches (114 mm by 317 mm), with the long dimension parallel to the warp direction of the cloth. It has been found that the pattern of some cloth may cause the cloth to be more hazardous in one direction than in the other, in which case the long dimension of the specimen should be parallel to the more hazardous direction.

3. NUMBER OF DETERMINATIONS

3.1 Unless otherwise specified in the procurement document, five specimens shall be tested from each sample unit.

4. APPARATUS (see Fig. 5906)

4.1 Cabinet. The cabinet (A) for protecting the specimen from drafts shall be metal, 8 inches (203 mm) wide, 15 inches (381 mm) long, and 14 inches (356 mm) high, with a glass observation window (B) in the front. It shall have a removable cover (C) with a 1/2-inch (13 mm) ventilating clearance all around which contains two pyrex observation windows (D), one near each end of the cabinet. Each corner of the bottom shall have a support (J) so that the floor of the cabinet is raised 3/8 inch (10 mm) above the table top or other surface upon which it is placed. The bottom of the cabinet shall have five equally spaced 3/4 inch (19 mm) ventilating holes (O) along each side of the cabinet. An immersion thermometer shall be inserted through the center of the cover for registering the temperature of the cabinet. The cabinet shall have a slot in one end through which the specimen holder is inserted so as to slide on a horizontal supporting track (K) into test position (P), in which position the center of the end of the specimen is 3/4 inch (19 mm) above the top of the burner.

METHOD 5906

4.2 Electric strip heaters. Two electric strip heater (H) for maintaining the required temperature in the cabinet, one on each side of the cabinet just above the ventilating holes in the bottom.

4.3 Specimen holder. Specimen holder consisting of a clamp composed of two matching rectangular frames, each 15-1/2 inches (394 mm) long and 4 inches (102 mm) wide over-all. The two sections shall be aligned by means of two pins (M) at one end of the lower section which fit into corresponding holes in the upper section. The rectangular frames shall be 1 inch (25 mm) wide and 1/2 inch (13 mm) in thickness, made from strips of nickel-plated steel, chromeplated steel, or other material that will not corrode.

4.3.1 Marking wires. Heat-resistant marking wires (N) attached to the upper section in such a manner that they will not touch the specimen but will cross it at right angles. One wire shall be 1-1/2 inches (38 mm) from the inside edge of the frame at the ignition end, and one wire shall be located 1 inch (25 mm) from the other end so that there will be a distance of 10 inches (254 mm) between the two wires. A third wire shall be placed across the upper section, 1/2 inch (13 mm) from the inside edge of the ignition end to serve as a guide for adjusting the position of the specimen in the holder. The open space framed inside the specimen holder shall be 2 inches (51 mm) wide and 13-1/2 inches (343 mm) long.

4.4 Combing device. Combing device consisting of a flat metal base 6 inches (152 mm) wide and 24 inches (610 mm) long, carrying a bracket to which a comb support is hinged in such a manner as to permit raising and lowering the comb. The comb shall be 4-1/2 inches (114 mm) wide and shall have 7 to 8 smooth rounded teeth per inch (per 25 mm). When the comb is in the lowered position, it shall rest on the base plate at an angle of 20 degrees. Means shall be provided for applying a total load of 250 g to the cloth when the comb is in contact with the cloth.

4.5 stop. stop (not shown in the figures) for use with double-napped cloth. The stop shall consist of a cross strip of 26-gage sheet steel, 1/4 inch (6 mm) wide, removable and fitted on the lower frame of the specimen holder, midway of its thickness or 1/4 inch (6 mm) below the cloth mounting plane. It shall cross the under surface of the specimen about 3 inches (76 mm) from the end to be ignited and far enough below the cloth to have no effect on the burning on the upper surface while preventing a quick flash over the lower surface.

4.6 Gas burner. Tirrill or Bunsen gas burner (E) with a 3/8 inch (10 mm) inside diameter tube, so located in the cabinet that the center of the end of the specimen shall be directly above the tip of the flame when the specimen is in place.

METHOD 5906

4.7 Gas regulator. Large wheel (F) extending outside the cabinet and attached to the gas supply valve of the burner so as to permit easy regulation of the height of the flame from outside the cabinet.

4.8 Means for gaging the height of the flame (G).

4.9 Timing device. Stop watch or other timing device which will indicate the time to 1/5 second.

5. PROCEDURE

5.1 Conditioning. The specimen shall be suspended vertically and heated in a circulating-air oven at a temperature of 140° to 145°F (60° to 63°C) for 4 ± 1/4 hours before testing. Only one specimen shall be removed from the oven at a time and immediately subjected to the flame test.

5.2 Plain cloth. The specimen shall be slipped into the holder which clamps each long edge leaving a center strip 2 inches (51 mm) wide and 12-1/2 inches (318 mm) long taut and exposed with 1/2 inch (13 mm) clearance between the frame and each end of the specimen.

5.2.1 With the burner flame turned as low as possible, the specimen holder containing the specimen shall be slipped through the slot in the end of the cabinet until the entire length of the specimen is barely within the cabinet. The specimen shall be held in this position in the cabinet for a 2-minute reconditioning period before the test is made. At the end of the reconditioning period, the specimen holder shall be drawn back to clear the burner and the burner adjusted to give a flame 1-1/2 inches (38 mm) in height with the air completely shut off.

5.2.2 The specimen holder containing the specimen shall then be slid on the supporting track (K) into test position (P) so that the end of the specimen is 3/4 inch above the top of the burner, and the specimen then ignited. The temperature of the inside of the cabinet shall be approximately 140°F (60°C) during the test. A 1-1/2 inch (38 mm) length of the specimen shall be burned before the timing device is started.

5.2.3 The time required for the flame to travel across a 10-inch (254 mm) length of the specimen shall be determined.

METHOD 5906

5.3 Napped cloth. If the cloth has a nap or tufting, the specimen shall be combed twice against the nap by drawing it slowly under the comb, taking 2 to 3 seconds for its passage. The cloth shall be maintained flat-against the base of the combing device while it is drawn under the comb. The specimen shall be placed in the specimen holder so that the flame will travel in the direction of the lay of the nap.

5.3.1 If the cloth is double-napped a stop shall be used to prevent a flash from traveling across the underside of the cloth and igniting the other end of the specimen before the flash has traveled across the upper surface. In other respects the procedure shall be as described for plain cloth (see 5.2).

6. REPORT

6.1 The flash or rate of burning of the sample unit shall be reported to the nearest 0.5 inch (13 mm) per minute or per second as applicable.

6.2 If the difference between any two Individual results obtained is less than 40 percent from the average of the specimens tested, the rate of burning of the sample unit shall be the average of the results obtained from the specimens tested.

6.3 If the difference between any two individual results obtained in 6.2 is more than 40 percent from the average, unless otherwise specified in the procurement document, 10 specimens shall be tested from each sample unit and the average of the 5 highest values reported as the rate of burning of the sample unit.

6.4 Each individual value used to calculate the average shall also be reported.

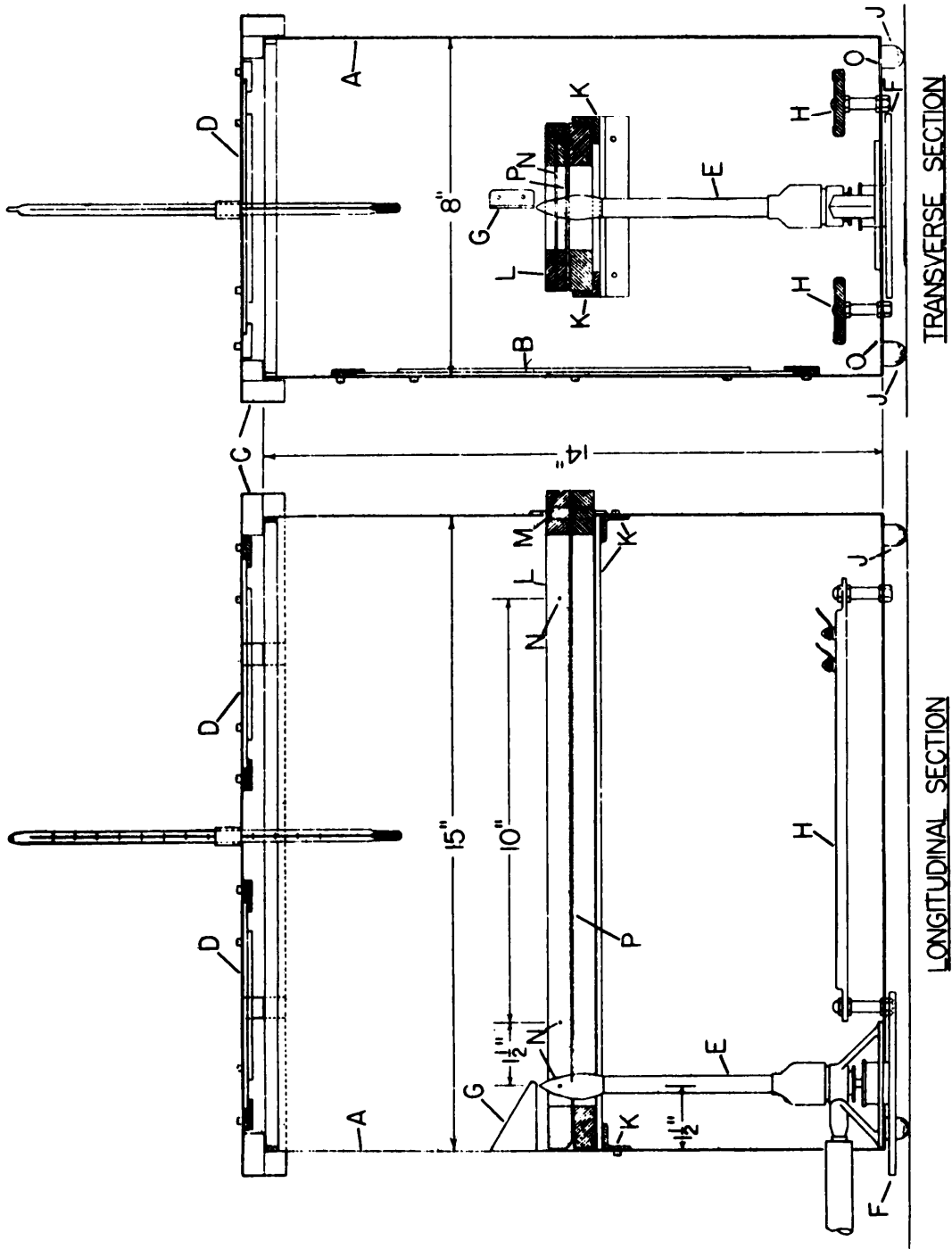

FIGURE 5906

METHOD 5907
July 20, 1978

FLAMMABILITY TEST FOR SLEEPING BAG CLOTHS; TABLET METHOD

1. SCOPE

1.1 This method is designed to determine whether a low heat flux ignition source, such as a match flame, will ignite certain cloths, especially cloths used for sleeping bags, and spread the flame to other component materials when these cloths are placed over a standard batting.

2. TEST SPECIMEN

2.1 The specimen shall be a 9 inch by 18 inch (229 mm by 457 mm) rectangular piece of cloth with the long dimension parallel to the warp or filling direction of cloth. No two specimens shall contain the same warp or filling yarns in the longitudinal direction of the specimen.

3. NUMBER OF DETERMINATIONS

3.1 Unless otherwise specified in the procurement document, five specimens from both the warp and filling directions shall be tested from each sample unit.

4. APPARATUS

4.1 Asbestos plates. Two 12 inch by 12 inch (305 mm by 305mm) square 1/4 inch (6 mm) thick asbestos plates (see 7.1).

4.2 Hood. A draft-free inclosure (a hood) with an exhaust to remove fumes developed during the test.

4.3 Standard batting (see 7.3). A 9 inch by 18 inch (229 mm by 457 mm) rectangular piece of polyester batting conforming to MIL-B-41826, Type V, (6 oz./sq. yd (203 g/m²) continuous filament batting without the cheese cloth).

4.4 Angle scale. A scale to measure angles to ± 1 degree.

4.5 Stop watch. A stop watch which will measure to 1.0 second.

4.6 Measuring scale. A measuring scale graduated in increments of 0.1 inch (1 mm).

FED. TEST METHOD STD. NO. 191A

METHOD 5907

4.7 Ignition tablet. A No. 1588 methenamine timed burning tablet or equal (see 7.2 and 7.2.1).

4.8 Drying oven. A circulating air oven thermostatically controlled and capable of maintaining the temperature at 200° to 230°F (93° to 110°C).

5. PROCEDURE

5.1 The test specimens shall be dried in a circulating air oven at a temperature of 221° ± 3°F (105° ± 5°C) for one hour before testing.

5.1.1 Only one specimen shall be removed from the oven at a time and tested immediately upon removal.

5.2 Place one of the asbestos plates in the draft-free inclosure (with exhaust off) with the back of the plate raised so that the front edge forms a 15° angle with the horizontal (see Figure 5907).

5.3 Preparation of test specimen. Superimpose the test cloth on the batting and fold in half with the batting on the inside of the folded ensemble. The specimen shall be handled carefully and not compressed by hand after folding.

5.4 Position and center the folded test ensemble on the inclined asbestos plate so that the folded edge of the ensemble is aligned with the lower edge of the plate. Check the alignment by using the second asbestos plate, held perpendicular to the horizontal, at the bottom edge of the inclined plate.

5.5 Place the ignition tablet at the center of one edge of the second asbestos plate. With the asbestos plate resting on the table surface, a few inches (mm) away from the test ensemble, ignite the tablet and slide the horizontal asbestos plate forward so that the leading edge, with the ignited tablet, contacts the lower edge of the inclined plate and the flame of the tablet contacts the test ensemble. The burning time of the tablet shall be measured, by means of a stopwatch, from the moment its flame touches the specimen until the moment it no longer touches the specimen. If the flame-to-specimen contact time is less than 90 seconds the results shall be rejected and an additional specimen tested.

5.5.1 The specimen shall remain in the test position until all flaming of the ignition tablet and the specimen has ceased. Should shouldering or after-glow of the specimen continue after the end of flaming, allow sufficient time to elapse to insure combustion has ceased.

FED. TEST METHOD STD. NO. 191A

METHOD 5907

5.6 After-flame time of specimen. Record the length of time the specimen continues to flame after the tablet flaming has ceased.

5.7 After-glow time of specimen. Record the length of time the specimen continues to glow after all flaming has ceased.

5.8 Char length of specimen. After both flaming and glowing have ceased, the specimen shall be removed from the batting, unfolded and placed on a flat surface to determine the char length. The char length shall be the length which is the greatest distance between any two points of charred area.

5.9 After each specimen is removed, the test area shall be cleared of fumes and smoke prior to testing the next specimen.

5.10 A new piece of batting shall be used for each specimen tested.

6. REPORT

6.1 The after-flame time, after-glow time and the char length of sample unit shall be the average of the results obtained from the individual specimens tested.

6.1.1 Each individual value used to calculate the average shall also be reported.

6.2 The after-flame time and after-glow time shall be reported to the nearest 1.0 second.

6.3 The char length shall be measured to the nearest 0.1 inch (1 mm)

7. NOTES

7.1 Asbestos base plates used in the Department of Commerce Carpet and Rug Test; DOC 1-70 are satisfactory for use in this test.

7.2 A "timed burning tablet" may be obtained from Eli Lilly Co., Indianapolis, IN 46206. Product Number 1588 in Cat. No. 79, Dec. 1, 1969.

7.2.1 The ignition (burning) tablets shall be stored in a desiccator over a desiccant for 24 hours prior to use. (Small quantities of sorbed water may cause the tablets to fracture when first ignited. If a major fracture occurs, any result from that test shall be ignored and the test shall be repeated.)

7.3 The standard batting may be obtained from Celanese Fiber Company, P.O. Box 1414, Charlotte, NC 28201.



FIG. 5907 - TABLET FLAMMABILITY TEST FOR SLEEPING BAG FABRICS

METHOD 5908
July 20, 1978

FLAMMABILITY, BURNING RATE OF CLOTH; 45° ANGLE

1. SCOPE

1.1 This method is intended for determining the flammability of cloth by measuring the rate of burning or flashing and the ease of ignition. It is satisfactory for use with cloth that has not been flameproofed.

2. TEST SPECIMEN

2.1 Unless otherwise specified in the procurement document, the specimen shall be a rectangle of cloth 2 inches by 6 inches (51 mm by 152 mm) with the long dimension parallel to the warp direction in plain cloth and to the lay of nap in napped cloth. It has been found that the pattern of some cloth may cause the cloth to be more hazardous in one direction than in the other, in which case the long dimension of the specimen should be parallel to the more hazardous direction.

3. NUMBER OF DETERMINATIONS

3.1 Unless otherwise specified in the procurement document, five specimens shall be tested from each sample unit.

4. APPARATUS (Figure 5908)

4.1 Metal hood or cabinet. Metal hood or cabinet (A) to prevent circulation of air around the specimen rack and the flame, permitting free ventilation for rapid oxidation. There are twelve 1/2 inch (13 mm) holes equidistant along the rear of the top closure. A glass door (K, front view shown) which slides up and down in the grooves at the front of the cabinet shall be provided. The door shall have a catch mechanism (J) for holding the door in an open condition for inserting the specimen. A draft ventilating strip (not shown) shall be placed across the front opening to seal the space between the sliding door, when the door is in the lowered position, and the base on which the specimen holder is attached.

4.2 Specimen rack. The specimen rack shall provide support for the frames in which the specimens are mounted. The angle of inclination shall be 45 degrees (B). Two guide pins shall project downward from the center of the base of rack, travel in slots provided in the floor of the chamber so that adjustments can be made for the thickness of the specimen in relation to the flame front. A stop is provided in the base of the chamber to assist in adjusting the position of the rack.

FED. TEST METHOD STD. NO. 191A

METHOD 5908

4.2.1 Specimen holder. The specimen holder shall consist of two 1/16 inch (2 mm) thick matched metal plates with clamps mounted along the sides, between which the specimen is fixed (C). The plates shall be slotted and loosely pinned for alignment. The two plates of the holder shall cover all but 1-1/2 inches (38 mm) of the width of the specimen for its full length. The specimen holder is supported in the draft-proof chamber on a rack at an angle of 45°.

4.2.2 Specimen rack, held in position by two knobs, which can be reached under the stage of the cabinet. When the knobs are loosened the holder can be moved forward and backward.

4.2.3 An indicating finger is provided, the fore part of which touches the specimen when the rack is correctly adjusted (D).

4.3 Gas jet. Gas jet consisting of a 26-gage hypodermic needle protected by a copper shield (F).

4.4 Stopcord. Stopcord supplied from a spool of No. 50 mercerized cotton sewing thread which is fastened to the side of the chamber (P). The cord can be withdrawn by releasing the thumbscrew holding the spool in position. The cord for measuring the vertical flame height shall be stretched from the spool down over the top of the holder, through the loops in the shield, and across through a pulley or eye on the opposite side of the cabinet (H).

4.4.1 A weight (I) shall be attached to the end of the cord in such a position that when it drops it actuates the mechanism which stops the timing device.

4.4.2 Another loop shall be installed on the rear panel of the cabinet behind "G" (not shown in figure) so that the cord is drawn away from directly over the flame.

4.5 Fuel supply. Fuel supply consisting of a No. 4 cylinder of c.p. butane (M), of 2-pound (0.9 kg) capacity.

4.6 Fuel control valve. Sensitive control valve (L) for regulating the fuel supply at the tank. The valve ends in a 1/2 inch (13 mm) female connection for attachment to the standard butane tank.

4.7 Flow meter. Flow meter (not shown) to bring the fuel supply to test level by means of the control valve. The flow meter shall consist of a U-shaped glass tube cut into the gas line as to register the gas pressure delivered to the micro-burner. A movable metal plate with two parallel horizontal lines 1 inch apart (25 mm) shall be attached to the case wall behind the flow meter. When the pressure is off, the plate is so regulated that the water level in both sides of the U-tube meets the lower line. When the test is made, the pressure shall be so adjusted that the higher liquid level in the U-shaped tube meets the upper line.

METHOD 5908

4.8 Stopwatch. Stopwatch (N) or other timing device to indicate the time in seconds, accurate to 1/5 second.

4.9 Driving mechanism. Driving mechanism on the rear of the cabinet (not shown) to move the gas jet to its most forward position and to automatically start the timing device at the moment of flame impact. When the cord (G) is severed by the flame, the falling weight (I) stops the watch.

4.10 Starting lever. Starting lever (O) which can be operated from left to right in one stroke and which, when released, shall operate the gas jet.

4.11.1 Brushing device. Brushing device consists of a baseboard over which a smaller carriage is drawn. This carriage runs on parallel tracks attached to the upper surface of the baseboard. The brush is hinged with pin hinges at the rear edge of the baseboard and rests on the carriage vertically with a pressure of 150 go

4.11.1 The brush shall have two rows of stiff nylon bristles mounted with the tufts in a staggered position. The bristles are 0.016 inch (0.40 mm) in diameter and 0.75 inch (19 mm) in length. There are 20 bristles per tuft and four tufts per inch (25 mm). A clamp is attached to the forward edge of the movable carriage to permit holding the specimen on the carriage during the brushing operation.

4.12 Drying oven. A circulating air oven thermostatically controlled and capable of maintaining the temperature at 200°F to 230°F (93°C to 110°C).

5. PROCEDURE

5.1 Preparation of specimen.

5.1.1 Napped or pile cloth. The direction of the lay of the nap or pile face shall be determined. Unless otherwise specified in the procurement document, a rectangle 2 inches by 6 inches (51 mm by 152 mm) with the long dimension parallel to the lay of the nap or pile shall be marked on the specimen back. Before cutting, the specimen shall be marked with a staple in the center of the end toward which the nap or pile points. As the required number of specimens are cut, each specimen shall be placed on the brushing device and drawn under the brush once against the lay of the napped or pile surface as described in 5.1.1.1. The specimen shall be immediately conditioned as described in 5.2.

5.1.1.1 Brushing. After the specimen has been put in place on the carriage and fastened by means of the clamp, the brush is raised, the carriage pushed to the rear, and the brush lowered to the face of the specimen. The carriage is then drawn forward by hand at a uniform rate.

5.1.2 Plain cloth. The specimen shall be the same size and prepared in the same reamer as that from pile or napped cloth, 5.1.1, except that it shall not be brushed. The specimen shall be immediately conditioned as described in 5.2.

METHOD 5908

5.2 Condition of specimen. The mounted specimen shall be dried in a horizontal position in a circulating-air oven at a temperature of $221^{\circ}\pm 5^{\circ}$ F ($105^{\circ}\pm 3^{\circ}$ C) for 30 minutes. The specimens are removed from the oven and placed over anhydrous calcium chloride in a desiccator until cool.

5.3 Flammability test.

5.3.1 The control valve from the fuel supply shall be opened and adjusted to the test level. Approximately 5 minutes is required to drive all the air from the fuel line. After this interval, normally approximately 5 minutes, the gas shall be ignited. The flame under conditions of test should be approximately 5/8 inch (16 mm) in length, measured from its tip to the opening in the gas nozzle.

5.3.2 Individual specimens shall be removed from the desiccator. In the case of napped or pile surface. Plain cloth shall not be brushed. The specimen shall be placed on the specimen rack in the chamber. Not more than 45 seconds shall elapse from the time the specimen is removed from the desiccator until the application of the flame.

5.3.3 The specimen rack with the specimen in position shall be brought forward to the point where the indicating finger touches the face of the specimen.

5.3.4 The cord shall be strung through the guides in the upper plate of the specimen holder across the top of the specimen through the loop on the rear panel and over the guide ring (H). The weight shall be hooked in place close to and just below the guide and the slide door closed. The stopwatch shall be set at zero. The apparatus shall be at room temperature at the start of the test, and the test conducted in a draft-free room.

5.3.5 The starting lever shall be brought over to the extreme right and released. This starts the timing mechanism and applies the gas jet to the face of the specimen for a period of 1 second. The timing shall be automatic, starting upon the application of the flame and ending when the cord burns through at the end of the specimen, and the weight is released. Total time shall be recorded to the nearest 1/5 second.

6. REPORT

6.1 The flammability of the sample unit shall be the average of the results obtained from the specimens tested and shall be reported to the nearest 1/5 second.

6.2 The individual values used to calculate the average shall also be reported.

7. NOTES

7.1 The flammability test apparatus described in this METHOD MAY BE OBTAINED from Custom Scientific Instruments, Inc., 13 Wing Drive, Whippany, NJ 07981.

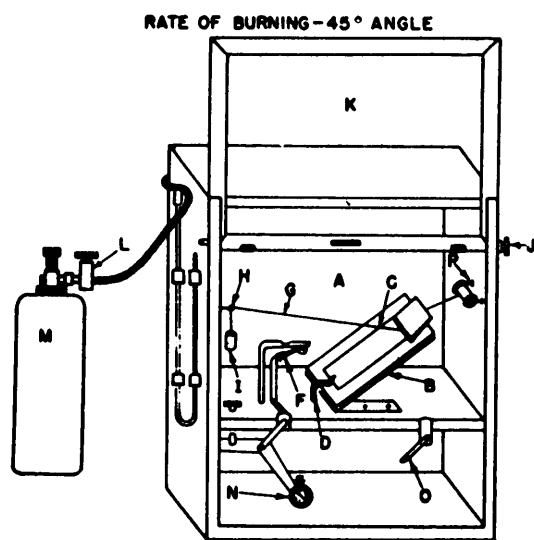

FIGURE 5908

METHOD 5920
July 20, 1978

HEATING (SPONTANEOUS) OF CLOTH

1. SCOPE

1.1 This method is applicable to all cloths and it may be used to determine the tendency of a cloth to undergo self-heating at moderate temperatures below 212°F (100°C).

2. TEST SPECIMEN

2.1 The specimen shall be a strip of cloth approximately two inches (51 mm) wide and long enough to make a roll approximately 1-1/2 inches (38 mm) in diameter.

3. NUMBER OF DETERMINATIONS

3.1 Unless otherwise specified in the procurement document, two specimens shall be tested from each sample unit.

4. APPARATUS (Figure 5920)

4.1 Double boiler. A double boiler made of corrosion-resistant metal such as copper or brass. The inside chamber shall be four inches (102 mm) in diameter by 7 inches (178 mm) deep, equipped with a cylindrical wire screen 1-1/2 inches (38 mm) in diameter and 6 inches (152 mm) long to hold the specimen and shall be surrounded by a water jacket containing water maintained at the boiling temperature.

4.1.1 The water jacket shall be provided with an opening to permit the addition of water and a reflux condenser (air-cooled) in order to maintain a constant water level.

4.1.2 Insulated cover consisting of a double-walled section, 3-15/16 inches (100 mm) in diameter and 3/4 inch (19 mm) thick filled with rock wool, supported on the cell by a flange fitted with a felt gasket. The cover shall have three openings, each 1/2 inch (13 mm) in diameter. The center opening provides a place to insert the thermometer. The other two openings shall be fitted with 1/2 inch (13 mm) diameter tubes, one of which extends 5 inches (127 mm) above the lid and the other 5 inches (127 mm) down into the cell to provide for air circulation through the cell.

4.2 A multiple unit of the same cell design may be used.

FED. TEST METHOD STD. NO. 191A

METHOD 5920

5. PROCEDURE

5.1 Conditioning. The specimen shall be suspended and heated in a circulating air oven at a temperature of 140° to 145°F (60° to 63°C) for $4 \pm 1/4$ hours before testing. Only one specimen shall be removed from the oven at a time and immediately introduced into the specimen holder.

5.2 Before the *specimen* is introduced into the chamber, the apparatus is assembled with lid and thermometer in place, and the water in the outer jacket boiled until equilibrium is established and the thermometer gives a constant reading. This initial temperature of the empty specimen chamber is the reference point above which self-heating is evidenced, and is the initial temperature of the specimen.

5.3 The specimen shall be wound into a roll approximately 1-1/2 inches (38mm) in diameter so that a space is left in the center for the thermometer. The roll shall be slid into the wire screen provided to hold the specimen, and the assembly put into the air chamber. The lid shall be put on and the thermometer adjusted so that the bulb is at the center of the roll. The water in the jacket shall be boiled for four hours, and the temperature in the cloth roll shall be noted at intervals of sufficient frequency to permit the determination of the highest temperature reached. The last temperature reading shall be made at the end of the four hour boiling period.

6. REPORT

6.1 The self-heating of the sample unit shall be the average of the results obtained from the specimens tested and shall be reported to the nearest 0.5°F (1.0°C). Individual results used to calculate the average shall also be reported.

6.2 The initial temperatures of the specimen and the highest temperature reached for each specimen tested shall also be reported in degrees F (degrees C).

7. NOTES

7.1 The apparatus described in this test method is not commercially available and therefore must be either fabricated or custom made.

SPONTANEOUS HEATING APPARATUS

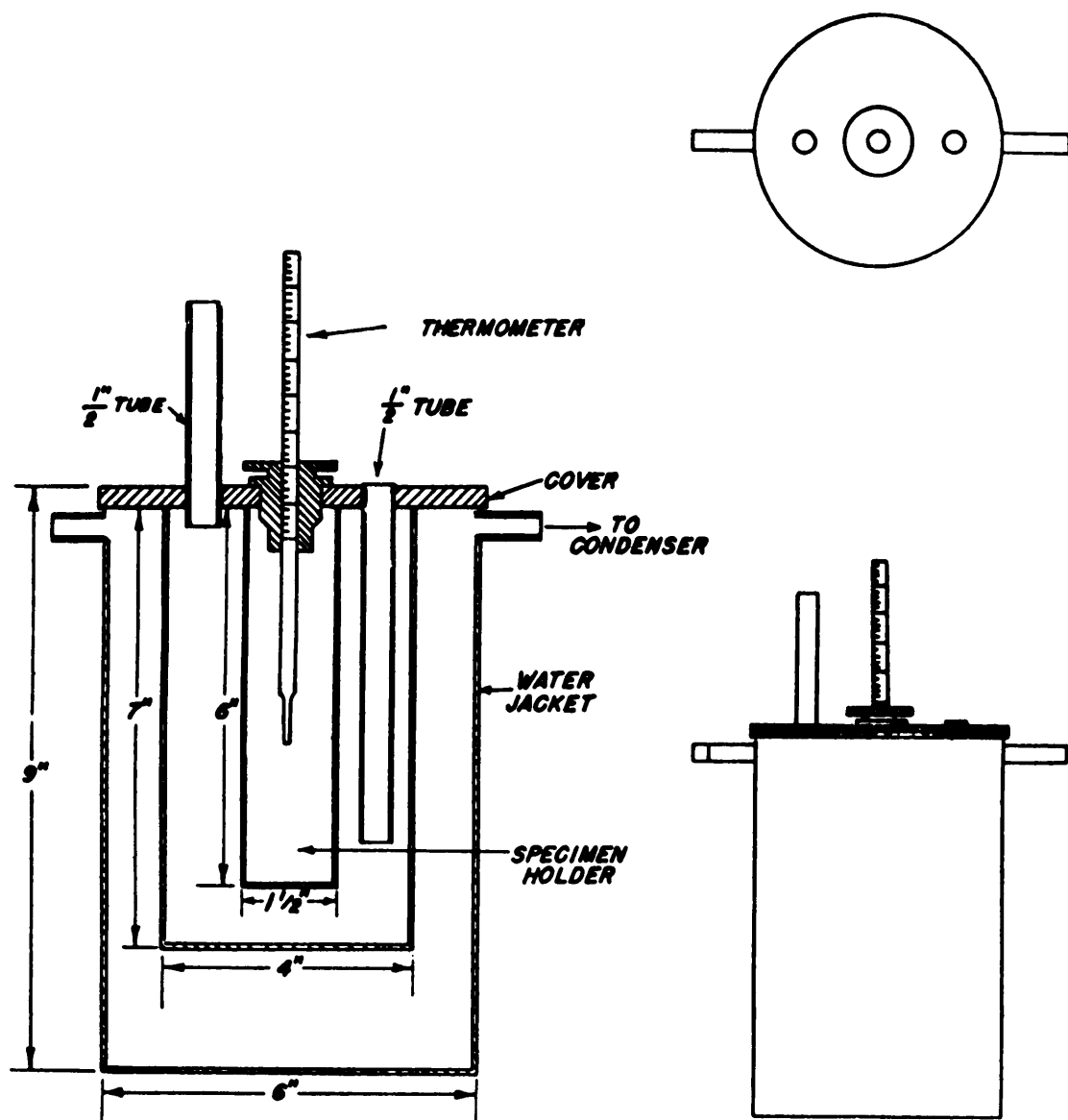

FIGURE 5920

METHOD 5930
July 20, 1978

ELECTRICAL RESISTIVITY OF FABRICS; DETERMINATION OF

1. SCOPE

1.1 This method is intended for determining the surface electrical resistivity of fabrics.

1.2 The electrical resistivity influences the accumulation of electrostatic charge on a fabric.

1.3 This method is not applicable to fabrics containing stainless steel or other highly conductive components.

2. TEST SPECIMEN

2.1 The size of the specimen shall be such that its width does not exceed the width of the electrodes of the equipment being used.

2.1.1 The specimens shall be such that no two specimens contain the same set of warp and filling yarns.

3. NUMBER OF DETERMINATIONS

3.1 Unless otherwise specified in the procurement document, six specimens from each side of the fabric, three from each of warp and filling directions (12 specimens) shall be tested from each sample unit.

4. APPARATUS

4.1 Conditioning and testing chamber. A conditioning and testing chamber capable of providing relative humidity control of ± 2 percent preferably effective over a range of 25-65 percent, relative humidity and temperature control of $\pm 0.5^\circ\text{F}$ ($\pm 1^\circ\text{C}$) with circulating air.

4.2 Electrical resistance meter. An electrical resistance meter capable of measuring values in the range of 10^8 to 10^{13} ohms or higher, in conjunction with the electrode system (see 7.1).

4.2.1 Standard resistors for calibration of the electrical resistance meter (see 7.2).

4.3 Radioactive bar. A radioactive bar suitable for the removal of electrostatic charges from the fabrics (see 7.3).

METHOD 5930

5. PROCEDURE

5.1 Conditioning of specimens. Unless otherwise specified in the procurement document the test specimens shall be conditioned from the dry side for at least four hours in the conditioning chamber at 40 percent R.H. and 75°F (24°C) until equilibrium is reached in accordance with the criteria defined in Section 4 of this Standard.

5.1.1 The test specimens shall be hung in the conditioning test chamber in such a way as to allow good air circulating around the specimens.

5.1.2 All handling and testing of specimens after conditioning shall be done in the conditioning test chamber.

5.2 The static charges from the surface of the fabric shall be removed by passing the radioactive bar over both sides of the fabric.

5.3 The electrical resistance meter shall be operated in accordance with the manufacturer's instructions of the particular instrument being used and shall be calibrated periodically using standard resistors.

5.4 The specimen shall be placed in firm contact with the electrodes with the direction of test perpendicular to the adjacent edges of the electrodes.

5.4.1 The electrical current shall be 80 to 100 V at one inch (25 mm) electrode separation for one minute.

5.4.2 The electrical current shall be allowed to pass through the fabric for a minimum period of one minute and until a constant reading is obtained. The criteria for constant electrical resistivity shall be a change in the value of Log R of less than 0.1 units per minute.

5.5 The resistivity in ohms per square shall be calculated as follows:
Resistivity in ohms per square =

$$\frac{\text{Measured resistance in ohms} \times \text{Width of specimen}}{\text{Distance between electrodes}}$$

60 REPORT

6.1 Fabric having no definite face side. The electrical resistivity shall be the average of the calculated values of both sides of fabrics in each of the warp and filling directions.

6.2 Fabric having a definite face side. The electrical resistivity shall be the average of the calculated values and shall be reported separately for face and back in each of the warp and filling directions.

7. NOTES

7.1 Following is a partial listing of the electrical resistance meters found suitable for this test.

7.1.1 Cenco Electronic Electrometer, Central Scientific Company, 1700 Irving Park Road, Chicago, IL 60613.

7.1.2 Electronic Instruments Megohmmeter, Model 29-A, Herman H. Sticht Company, Inc., 27 Park Place, New York, NY 10007.

7.1.3 Beckman Ultrahmmeter, Beckman Instruments, Inc., 2500 Harbor Blvd., Fullerton, CA 92634.

7.1.4 Teraohmmeter, Siemens America, Inc., 350 Fifth Avenue, New York, NY 10001.

7.1.5 Hayek and Chromey Instrument, described in American Dyestuff Reporter, 40, 164-8 (1951).

7.1.6 Electrical Resistance Tester Model CS-51; Custom Scientific Instruments, Inc., 13 Wing Drive, Whippany, NJ 07981.

7.2 Standard resistors for calibration of the electrical resistance meter may be obtained from Victoreen Instrument Company, 10101 Woodland Avenue, Cleveland, OH 44104.

7.3 The following radioactive bar has been found to be suitable for the removal of electrostatic charges from fabrics: Staticmaster Ionizing Unit, Model 2U 500, Nuclear Products Company, 10173 E. Rush St., El Monte, CA 91733.

METHOD 5950
July 20, 1978

ADHESION OF PLIED (DOUBLE TEXTURE) FABRIC

1. SCOPE

1.1 This method is intended for determining the adhesion of the plies of plied (double texture) fabrics.

2. TEST SPECIMEN

2.1 The specimen shall be a rectangular piece of the fabric 2 inches (51 mm) wide by not less than 6 inches (152 mm) long, with the long dimension parallel to the warp or filling yarns of one of the outside plies of the fabric.

3. NUMBER OF DETERMINATIONS

3.1 Unless otherwise specified in the procurement document, five specimens shall be tested from each sample unit.

4. APPARATUS AND METHOD CITED

4.1 Apparatus.

4.1.1 A tester and 1 utographic recording mechanism as described in Method 5100 shall be used, except that the distance between the clamps shall be 2 inches (51 mm) at the start of the test and the face of each jaw shall be not less than 1 by 2 inches (25 by 51 mm).

4.2 Method cited.

Method 5100, Strength and Elongation, Breaking of Woven Cloth; Grab Method.

5. PROCEDURE

5.1 The plies shall be separated at one end of the specimen by hand, for approximately 2 inches (51 mm), and a ply placed in each clamp of the machine. If the fabric contains more than two plies, the outside plies shall be placed in the clamps. The pawls or maximum load attachments of the machine shall be disengaged during the test. The clamps shall be separated at the rate of 12 Inches \pm 0.5 inch per minute (305 mm \pm 13 mm/min) until the plies are separated over the remaining portion of the specimen. The resistance to separation shall be registered by means of the autographic recording device. Care shall be taken that any cut threads along the edge of the specimen do not interfere with the separation, that the specimen separates over the full width, and that no tearing occurs in the plies at the point of separation.

FED. TEST METHOD STD. NO. 191A

METHOD 5950

6. REPORT

6.1 Adhesion of specimen. The adhesion of the specimen shall be the average of the five highest peak loads of resistance per 2 inch (51 mm) width registered for 3 inches (76 mm) of separation of the plies. If the number of peak loads is less than five, the average of the loads for the lesser number of peaks shall be the adhesion of the specimen.

6.2 Adhesion of the sample unit. The adhesion of the plies of the sample unit shall be the average of the results obtained for the specimens tested and shall be reported to the nearest 0.1 pound per 2 Inch width (to the nearest 10N/m).

6.3 Each individual value used to calculate the average shall also be reported.

METHOD 5951
July 20, 1978

BOND STRENGTH OF BONDED AND LAMINATED APPAREL CLOTHS

1. SCOPE

1.1 This method is intended to determine the bond strength required to separate component layers of bonded and laminated cloths under specified conditions.

2. TEST SPECIMENS

2.1 The specimen shall be a rectangular piece of cloth 3 inches by 6 inches (76 mm by 152 mm) with the length of the specimen corresponding to the warp direction of the cloth. Do not take specimens closer to the selvage than a distance equal to 20 percent of the cloth width. No two specimens shall contain the same warp and filling yarns.

3. NUMBER OF DETERMINATIONS

3.1 Unless otherwise specified in the procurement document, five specimens shall be tested from each sample unit.

4. APPARATUS AND METHOD CITED

4.1 Apparatus.

4.1.1 A tester and autographic recording mechanism as described in Method 5100 shall be used.

4.2 Method cited.

4.2.1 Method 5100, Strength and Elongation, Breaking of Woven Cloth;
Grab Method.

5. PROCEDURE

5.1 Unless otherwise specified in the procurement document, this test shall be performed on material conditioned in accordance with Section 4 of this Standard.

5.2 The upper and lower jaws shall be a minimum of 1 inch by 3 inches (25 mm by 76 mm), with the longer dimension perpendicular to the application of load.

METHOD 5951

5.3 Gage length, the distance between the jaws at the start of the test, shall be 2 inches (51 mm).

5.4 The tester shall be operated at a uniform pulling speed of 12 Inches \pm 0.5 in/rein (305mm \pm 13 mm/min).

5.5 If the indicating scale on the tester is equipped with a pawl and ratchet mechanism, disengage the mechanism to permit readings of variable force when the tester is placed in operation.

5.6 The two layers of cloth shall be separated, by hand, along the 3 inch (76 mm) width of the specimen for a distance of approximately 2 Inches (51 mm), in the direction of the specimen length.

5.7 Bonded cloths (see 7.2.2). Secure the separated face cloth of the specimen in the upper clamp of the tester in such away that the longitudinal axle of the specimen forms a right angle with the closed clamping surface. Secure the separated backing cloth in the lower clamp of the tester in such away that the longitudinal axis of the specimen forms a right angle with the closed clamping surface.

5.8 Laminated cloths (see 7.2.3). Separate plies and secure the specimen as in para. 5.6 and 5.7 for the face and foam of the laminated specimen.

5.8.1 If the foam is laminated to a backing cloth, retain each specimen from 5.8. Separate the backing cloth from the foam as In para. 5.6 except that the separation shall be made at the opposite end of the specimen separated for the face-to-foam test.

5.9 Calculation of bond strength. Determine the bond strength of each specimen to the nearest 0.5 oz. (0.1 N), as the average of the five highest and five lowest peak loads of resistance, per 3 inches (76 mm) of specimen width, recorded for 3 inches (76 mm) of separation of the plies.

6. REPORT

6.1 The bond strength of the sample unit shall be the average of the results obtained for the specimens tested and shall be reported to the nearest 0.5 ounce per 1 inch width (to the nearest 5N/m).

6.2 Each individual value used to calculate the average shall also be reported.

7. NOTES

7.1 When testing laminated cloths, examine both sides of the foam on the test specimen. Determine whether the foam ruptured during delamination (see 7.2.4)

METHOD 5951

allowing some foam to adhere to either cloth surface. If this occurs, make the notation "foam tear" for that specimen for the side or sides where foam tear occurred.

7.2 Definitions.

7.2.1 Bond strength. The tensile force expressed in ounces per 1 inch (newtons per meter) of width, required to separate the component layers under specified conditions.

7.2.2 Bonded cloth. A layered cloth structure wherein a face cloth is joined to a backing cloth, such as tricot, with an adhesive that does not significantly add to the thickness of the combined cloth.

7.2.3 Laminated cloth. A layered cloth structure wherein a face cloth is joined to a continuous sheet material, such as polyurethane foam, in such a way that the identity of the continuous sheet material is retained, either by the flame method or by an adhesive, and this in turn usually is joined on the back with a backing cloth such as tricot.

7.2.4 Delamination. Separation of the plies through failure of the adhesive.

METHOD 5960
July 20, 1978

ADHESION OF CEMENTED SEAMS

1. SCOPE

1.1 This method is intended for determining the adhesion of cemented lapped seams which have not been stitched. It is applicable to cemented seams of such items as raincoats, ponchos, flotation bladders, and coated bags.

2. TEST SPECIMEN

2.1 The specimen shall be a seam approximately 6 inches (152 mm) in length and the full width of the seam.

3. NUMBER OF DETERMINATIONS

3.1 Unless otherwise specified in the procurement document, five specimens shall be tested from each sample unit.

4. APPARATUS AND METHOD CITED

4.1 Apparatus.

4.1.1 A tester and autographic recording mechanism as described in Method 5100, except that the clamps shall be of sufficient width to grip the full width of the seam.

4.2 Method cited.

Method 5100, Strength and Elongation, Breaking of Woven Cloth; Grab Method

5. PROCEDURE

5.1 The cemented seam shall be separated by hand for a distance of 2-1/2 to 3 inches (64 mm to 76 mm) and the separated ends inserted in the clamps of the machine.

5.2 The jaws shall be separated at a rate of 12 inches \pm 0.5 inch per minute (305 mm \pm 13 mm/min) until approximately 3 inches (76 mm) of the seam to separation shall be registered by means of the autographic recording mechanism.

6. REPORT

6.1 Adhesion of specimen. The adhesion of the specimen shall be the average of the five highest peak loads of resistance registered for 3 inches (76 mm) of separation of the cemented seam divided by the width of the seam in inches. If the number of peak loads is less than five, the average of the loads for the lesser number of peaks divided by the width of the seam in inches shall be the adhesion of the cemented seam specimen.

METHOD 5960

6.2 Adhesion of samle unit. The adhesion of the cemented seam of the sample unit shall be the average of the results obtained from the specimens tested and shall be reported to the nearest 0.1 pound (to the nearest 0.1 N).

6.3 Each individual value used to calculate the average shall also be reported.

METHOD 5962
July 20, 1978

ADHESION OF STRAPPED SEAMS

1. SCOPE

1.1 This method is intended for determining the adhesion of strapped seams. IT is applicable to the strapped seams of such items as rainwear, coated bags and toxicological agents protective garments.

2. TEST SPECIMEN

2.1 The specimen shall be a piece of the seam approximately 6 inches (152 mm) in length and the full width of the strap.

3. NUMBER OF DETERMINATIONS

3.1 Unless otherwise specified in the procurement document, five specimens shall be tested from each sample unit.

4. APPARATUS AND METHODS CITED

4.1 Apparatus.

4.1.1 A tester and autographic recording mechanism as described in Method 5100, except that the clamps shall be of sufficient width to grip the full width of the seam.

4.2 Method cited.

Method 5100, Strength and Elongation, Breaking of Woven Cloth; Grab Method.

5. PROCEDURE

5.1 The strapped seam shall be separated by hand for a distance of 2-1/2 to 3 inches (64 mm to 76 mm) and the separated ends inserted in the clamps of the machine.

5.2 The jaws shall be separated at a rate of 12 inches \pm 0.5 inch per minute (305 mm \pm 13 mm/min). The strapping shall be mounted in the movable clamp of the testing machine and pulled away from the seam from the 3 inch (76 mm) mark to complete separation of the specimen, and the resistance to such separation registered by means of the autographic recording mechanism.

FED. TEST METHOD STD. NO. 191A

METHOD 5962

6. REPORT

6.1 Adhesion of specimen. The adhesion of the specimen shall be the average of the five highest peak loads of resistance registered for 3 inches (76 mm) of separation of the strapped seam divided by the width of the seam in inches (mm). If the number of peak loads is less than five, the average of the loads for the lesser number of peaks divided by the width of the seam in inches (mm) shall be the adhesion of the strapped seam specimen.

6.2 Adhesion of sample unit. The adhesion of the strapped seam of the sample unit shall be the average of the results obtained from the specimens tested and shall be reported to the nearest 0.1 pound (to the nearest 0.1 N).

6.3 Each individual value used to calculate the average shall also be reported.

METHOD 5964
July 20, 1978

ADHESION OF WET SEAMS

1. SCOPE

1.1 This method is intended for determining the loss in adhesion of cemented lapped seams of coated cloth from wetting.

2. TEST SPECIMEN

2.1 The specimen shall be two pieces of the seam each 6 inches (152 mm) in length and the full width of the seam. They should be taken from adjacent parts of the seam, if possible.

3. NUMBER OF DETERMINATIONS

3.1 Unless otherwise specified in the procurement document, three specimens shall be tested from each sample unit.

4. APPARATUS AND METHODS CITED

4.1 Apparatus.

4.1.1 A tester and autographic recording mechanism as described in Method 5100, except that the clamps shall be of sufficient width to grip the full width of the seam.

4.2 Methods cited.

Method 5100, Strength and Elongation, Breaking of Woven Cloth; Grab Method.

Method 5960, Adhesion of Cemented Seams.

5. PROCEDURE

5.1 One piece of seam shall be immersed in water at a temperature of $75^{\circ} \pm 5^{\circ}\text{F}$ ($24^{\circ} \pm 3^{\circ}\text{C}$) for 2 hours, removed from the water, and while still dripping wet tested by the procedure specified in Method 5960.

5.2 The other piece of seam without immersion shall be similarly tested.

FED. TEST METHOD STD NO.191A

METHOD 5964

6. REPORT

6.1 Loss in adhesion of specimen-. The loss in seam adhesion of the specimen shall be calculated as follows:

$$\text{Loss in seam adhesion, percent} = \frac{\text{difference in adhesion of wet and dry seams}}{\text{adhesion of the dry seam}} \times 100$$

6.2 Loss in adhesion of sample unit. The loss in adhesion of the seam of the sample unit shall be the average of the results obtained from the specimens tested and shall be reported to the nearest 0.1 percent.

6.3 Each individual value used to calculate the average shall also be reported.

METHOD 5970
July 20, 1978

ADHESION OF COATING; ADHESIVE METHOD

1. SCOPE

1.1 This method is intended for determining the resistance to separation of continuous film type coatings from cloth.

2. TEST SPECIMEN

2.1 The specimen shall be 2 rectangular 3 inch by 7 inch strips (76 mm by 178 mm) of the coated cloth prepared as specified in 5.1. Unless otherwise specified in the procurement document, the long dimension shall be parallel to the warp of the coated cloth.

3. NUMBER OF DETERMINATIONS

3.1 Unless otherwise specified in the procurement document, three specimens shall be tested from each sample unit.

4. APPARATUS AND METHOD CITED

4.1 Apparatus.

4.1.1 A tester and autographic recording mechanism as described in Method 5100 shall be used, except that the face of each jaw shall be not less than 1 inch by 2 inches (25 mm by 51 mm) with the long dimension perpendicular to the direction of the application of load.

4.1.2 Adhesive. The adhesive used in preparing the specimen as described in 5.1 shall be one of the following:

- a. A solventless cyanoacrylate adhesive (see 7.1.1)
- b. Adhesive (solvent type) (see 7.1.2)

Unless otherwise specified in the procurement document, adhesive (a) shall be used to obtain the proper adhesive bond. If a proper bond is not obtained with adhesive (a), adhesive (b) shall be used.

4.1.3 Glass plates. Two glass plates having dimensions of approximately 4 inches by 6 inches by 1/8 inch (102 mm by 152 mm by 3 mm).

4.1.4 Weight. A 10-pound (4.5 kg) weight.

4.1.5 Circulating air oven. A circulating air oven capable of maintaining a temperature of $219^{\circ} \pm 6^{\circ}\text{F}$ ($104^{\circ} \pm 3^{\circ}\text{C}$).

FED. TEST METHOD STD.NO. 191A

METHOD 5970

4.2 Method cited.

Method 5100, Strength and Elongation, Breaking of Woven Cloth; Grab Method.

5. PROCEDURE

5.1 Preparation of specimen. Unless otherwise specified in the procurement document, the coated side of a one-side coated cloth, or the more heavily coated side of a cloth which is coated on both sides shall be the side of the cloth to be tested. The surface of the coated cloth may be cleaned by wiping with a cloth which has been dipped in a mild soap solution, rinsing with distilled water and air drying prior to application of the adhesive. In order to facilitate separation of the specimen prior to adhesion testing, use either method as outlined in 5.1.1 or 5.1.2.

a. Adhesive a. One coat of adhesive.(a) shall be applied to the test sides of the two strips of coated cloth. The two strips shall then be placed one on top of the other with the adhesive coated sides together.

b. Adhesive b. Three coats of adhesive (b) shall be applied to the test sides of the two strips of coated cloth with a 15 minute drying time at room temperature after the first and second coats of adhesive, and a 5 minute drying time at room temperature after the third coat of adhesive. The two strips shall then be placed one on top of the other with the adhesive coated sides together.

5.1.1 Prior to application of the adhesive, a diagonal cut shall be made with a razor or knife across the end of the two strips of coated cloth through the coating on the test side of the base cloth.

5.1.2 When joining the two strips of coated cloth, a tab of paper shall be placed between the two strips at one end of the specimen. The tab shall not cover more than 1-1/2 inches (38 mm) of the length of the specimen.

5.2 The cemented strips shall be placed in a horizontal position between two glass plates. A 10-pound (4.5 kg) weight shall be placed on top of the sandwich assembly. When adhesive (a) is used, the total elapsed time from application of the adhesive to the placing of the 10-pound (4.5 kg) weight on the sandwich assembly shall be approximately 90 seconds.

5.3 When adhesive (a) is used, the specimen shall be left between the two plates for 20 to 28 hours at standard conditions as specified in Section 4 of this Standard. The specimen shall be removed from between the two plates and cut to a 2 by 6 inch (51 by 152 mm) test piece.

METHOD 5970

5.4 When adhesive (b) is used, the specimen shall be left between the two plates for 2 hours at room temperature; the assembly of specimen, plates and weights shall then be placed in a circulating air oven at a temperature of $219^{\circ} \pm 6^{\circ}\text{F}$ ($104^{\circ} \pm 3^{\circ}\text{C}$) for 1 hour. The specimen shall then be removed from between the two plates, cut to a 2 by 6 inch (51 by 152 mm) test piece, and cooled at standard conditions for 20 to 28 hours.

5.5 Adhesion. The specimen shall be separated by hand at one end for a distance of approximately 2 Inches (51 mm). One strip of the specimen shall be clamped in the immovable clamp of the testing machine and the other strip in the movable clamp. The pawls of the maximum load attachment of the testing machine shall be disengaged during the test. The movable clamp shall have a speed of 12.0 ± 0.5 inches (305 ± 13 mm) per minute for separating the coating from the base cloth of the specimen, and shall be recorded on the autographic mechanism. A minimum length of 3 inches (76 mm) of coating shall be separated by the testing machine during the adhesion test. Care shall be taken so that the coating separates completely from the cloth for the entire 2 inch (51 mm) width of the specimen.

5.6 When dry and wet adhesion tests are specified in the procurement document, the specimen shall be two rectangular 3 inch by 9 inch strips of the coated cloth prepared as specified in 5.1. When removed from between the glass plates, the specimen shall be cut to a 2 by 8 inch (51 by 203 mm) test piece. The dry adhesion test shall be stopped after a 3-inch (76 mm) separation has been reached. The specimen shall then be immersed in distilled water at room temperature for 24 hours, blotted dry, and the wet adhesion test determined on the remainder of the specimen.

6. REPORT

6.1 The adhesion of the specimen shall be the average of the 5 highest peak loads of resistance registered during the separation of the coating. If the coating is separated from the cloth at an average force greater than or less than that specified, or if the average force necessary to separate the specimen at the adhesive line is greater than that specified, the values obtained are valid and shall be reported. If the average force necessary to separate the specimen at the adhesive line is less than that specified, and the separation occurs at the adhesive line, the test shall be invalid, and another specimen shall be tested.

6.2 The adhesion of coating of the sample unit shall be the average of the results obtained from the specimens tested and shall be reported to the nearest 0.1 pound per 2 inch width (to the nearest 10 N/m).

6.3 The adhesive used in determining the adhesion of coating shall be reported.

METHOD 5970

6.4 Each individual value used to calculate the average shall also be reported.

7. NOTES

7.1 The following adhesives have been tested and found satisfactory for the described uses.

7.1.1 Eastman 910 cement may be purchased from the Armstrong Cork Co., Lancaster, PA 17603.

7.1.2 Boxer Liquid Plastic No. 700 may be purchased from Union Laboratories, Inc., Morganville Tennent Road, Morganville, NJ 07751.

FED. TEST METHOD STD. NO. 191A

METHOD 5972
July 20, 1978

STRENGTH OF COATING; WATER RESISTANCE METHOD

1. SCOPE

1.1 This method is intended for determining the adhesion of the coating of coated cloth by measuring loss in resistance to water penetration after the coated cloth has been stretched.

2. TEST SPECIMEN

2.1 The specimen shall be a square piece of coated cloth 6 inches by 6 inches (152 mm by 152 mm), cut in a direction at 45 degrees to the direction of the warp and filling of the base cloth.

3. NUMBER OF DETERMINATIONS

3.1 Unless otherwise specified in the procurement document, the number of specimens tested from each sample unit shall be as required in the method of test for determining the water resistance (see 5.1).

4. APPARATUS AND METHODS CITED

4.1 Apparatus.

4.1.1 The machine used to stretch the specimen as required shall be that described in Method 5100, except that the face of each jaw shall be 1 inch by 2 inches (25 mm by 51 mm), with the long dimension perpendicular to the direction of pull.

4.1.2 Stop watch or watch with a second hand.

4.2 Methods cited.

Method 5100, Strength and Elongation, Breaking of Woven Cloth; Grab Method

Method 5512, Water Resistance of Coated Cloth; High Range, Hydrostatic Pressure Method

Method 5514, Water Resistance of Cloth; Low Range, Hydrostatic Pressure Method

Method 5516, Water Resistance of Cloth; Water Permeability, Hydrostatic Pressure Method

5. PROCEDURE

5.1 The water resistance of the coated cloth shall be measured by one of the following Methods: 5512, 5514, or 5516, as specified in the procurement document.

FED. TEST METHOD STD. NO. 191A

METHOD 5972

5.2 A specimen of the coated cloth which has not been previously tested for water resistance shall be centered in the clamps of the machine (see 4.1.1) with the edges of the specimen parallel to the edges of the clamps. The pawls or maximum load attachments shall be disengaged during this test. The clamps shall be separated until a load of 30 pounds (133 N) has been applied to the specimen. This load shall be retained for 30 seconds after which the specimen shall be removed from the machine.

5.3 The procedure shall be repeated on the same specimen with the 30 pound (133 N) load applied at an angle of 90° to the direction of that in the first test. While still under a load of 30 pounds (133 N) the coating of the specimen shall be examined for cracks and breaks.

5.4 The specimen shall be removed from the machine and the water resistance of the stretched coated cloth determined by the method used in 5.1.

5.5 Calculation or results. The loss in water resistance of the sample unit shall be calculated as follows:

$$\text{Loss in water resistance, percent} = \frac{W-F}{W} \times 100$$

Where: W = Water resistance of unstretched cloth (see 5.1)
F = Water resistance of cloth after stretching (see 5.4)

6. REPORT

6.1 The adhesion of the coating of the sample unit shall be the loss in water resistance due to stretching the coated cloth and shall be reported to the nearest 0.1 percent.

6.2 Any breaking or cracking of the coating shall be recorded for each specimen tested.

METHOD 6000
July 20, 1978

LENGTH OF TEN TURNS; CORDAGE

1. SCOPE

1.1 This method is intended for determining the length of 10 turns (complete revolutions) of a single strand in twisted and plaited cordage.

2* TEST SPECIMEN

2.1 The test specimen shall be not less than 10 feet (3 m) (see 5.2).

3. NUMBER OF DETERMINATIONS

3.1 Unless otherwise specified in the procurement document, one determination shall be made on each sample unit.

4. APPARATUS

4.1 Measurement stick or metal tape. Yardstick, meterstick, metal tape, or other suitable measuring device graduated in increments of 1/8 inch (1 mm).

5. PROCEDURE

5.1 The specimen shall be laid out on a surface without tension, so that it is straight and free from kinks and curls. The surface used shall be a V- trough formed by two smooth flat planes.

5.2 The measurement shall be made not less than 5 feet (1.5 m) from the end of the specimen.

5.3 Determine the number of final strands in the finished cordage. Make a mark on one of the strands. Follow the marked strand for 10 complete revolutions of the strand, and make a second mark on the same side of the cordage. The distance between the two marks is the length of one twist times 10, the measurement shall be made to the nearest 1/8 inch (1 mm).

6. REPORT

6.1 The length of 10 turns of a single strand shall be reported to the nearest 1/8 Inch (1 mm).

70 NOTES

7.1 One turn of a single strand in a rope of twisted or plaited construction is the distance measured along a rope, parallel to its axis, in which the one strand makes one revolution around the rope. The measurement of 10 turns is made for convenience and accuracy of measuring.

METHOD 6000

7.2 It is recommended that this test be incorporated into procurement documents as an in-process procedure or if included as an end item test in the procurement document, that it be performed as a non-destructive test on the sample unit prior to other tests.

FED. TEST METHOD STD. NO. 191A

METHOD 6001
July 20, 1978

PICKS PER INCH (PICKS/CM); BRAIDED CORDAGE

1. SCOPE

1.1 This method is intended for determining the number of picks per inch (picks/cm) in braided cordage.

2. TEST SPECIMEN

2.1 The specimen for test shall be a single length of braided cordage as follows:

- a. Minimum of 24 inches (610 mm) for cordage up to 3/4 inch (19 mm) in circumference.
- b. Minimum of 10 feet (3 m) for cordage 3/4 inch (19 mm) in circumference and larger.

3. NUMBER OF DETERMINATIONS

3.1 Unless otherwise specified in the procurement document, three determinations shall be made on each sample unit for cordage up to 3/4 inch (19 mm) in circumference and one determination on each sample unit for cordage 3/4 inch (19 mm) in circumference and larger.

4. APPARATUS

4.1 Magnifying glass, 1 inch (25 mm).

4.2 Measurement stick or metal tape. Yardstick, meterstick, metal tape, or other suitable measuring device graduated in increments of 1/16 inch (1 mm).

4.3 Specimen holder. Clamp or other means for holding the specimen.

5. PROCEDURE

5.1 Unless otherwise specified in the procurement document, all tests shall be performed on material conditioned under Standard Atmospheric Conditions in accordance with Section 4 of this Standard.

5.2 One end of the specimen shall be held securely by a clamp or other means approximately two inches (51 mm) from one end. The other end shall be twisted in the direction opposite to the helical pattern formed by the carrier strands during the braiding operation so that the picks are aligned and parallel with the side of the cord.

FED. TEST METHOD STD. No. 191A

METHOD 6001

5.3 While the carrier strands are clamped in a parallel position, the number of picks per inch (picks/cm) in one line of stitches shall be counted and recorded. This procedure shall be repeated for a total of three times at points not less than 6 inches (152 mm) apart from each other for cordage up to 3/4 inch (19 mm) in circumference; and one time for cordage larger than 3/4 inch (19 mm).

6. REPORT

6.1 The number of picks per inch (picks/cm) of the sample unit shall be the average of the results obtained, or the single value from the specimen tested dependent upon the size of the cordage and shall be reported to the nearest whole pick.

6.2 Each individual value used to calculate the average shall also be reported for braided cordage under 3/4 inch (19 mm).

DIAMETER OF CORDAGE

1. SCOPE

1.1 This method is intended for determining the diameter of twisted and braided cordage 3/16 inch (5 mm) in diameter and under.

2. TEST SPECIMEN

2.1 The specimen for twisted cordage shall be a minimum of 6 feet (1.8m).

2.2 The specimen for braided cordage shall be a minimum of 10 feet (3 m).

3* NUMBER OF DETERMINATIONS

3.1 Unless otherwise specified in the procurement document, three specimens shall be tested from each sample unit.

3.1.1 Three measurements shall be made on each specimen.

4. APPARATUS

4.1 Tension apparatus. Any suitable device may be used for applying the required load.

4.2 Calipers. Calipers suitable for measuring the diameter of the specimen to the nearest 0.01 inch (0.25 mm).

5. PROCEDURE

5.1 A load equal to 1 percent of the minimum breaking strength shall be applied to the test specimen for 1 minute before taking measurements. The load shall be maintained until the required measurements are completed.

5.2 While the specimen is under tension, the 3 measurements shall be made with the calipers.

5.3 Each measurement shall be made at a different point on the specimen, not less than 2 turns apart on twisted cordage and not less than 3 feet (1 m) apart on braided cordage.

6. REPORT

6.1 The average of the 3 measurements made on a specimen shall be the diameter of that specimen and shall be reported to the nearest 0.01 inch (0.25 mm) .

METHOD 6002

6.2 The average of the diameter of the 3 specimens tested shall be reported as the final diameter of the sample unit to the nearest 0.01 inch (0.25 mm).

6.3 Each individual value used to calculate the average shall also be reported.

CIRCUMFERENCE OF CORDAGE

1. SCOPE

1.1 This method is intended for determining the circumference of twisted, plaited and braided cordage, 5/8 inch (16 mm) circumference and up. The measurement shall be made prior to determining breaking strength and elongation.

2. TEST SPECIMEN

2.1 Unless otherwise specified in the procurement document, the specimen shall be as required by Method 6015 or 6016, whichever is applicable for the determination of the breaking strength and elongation of the cordage being tested.

3. NUMBER OF DETERMINATIONS

3.1 Unless otherwise specified in the procurement document, one determination shall be made on each specimen tested as required by Method 6015 or 6016 whichever is applicable for determining the breaking strength and elongation of the cordage being tested.

4. APPARATUS AND METHODS CITED

4.1 Apparatus.

4.1.1 The device for applying the required load shall be the apparatus required by Method 6015 or 6016 whichever is applicable for determining the breaking strength and elongation of the cordage being tested.

4.2 Measuring filament. A monofilament yarn or metallic wire with a diameter not greater than 0.012 inch (0.3 mm) and of sufficient length to overlap when held snugly around the specimen being tested.

4.3 Measurement stick or metal tape. Yardstick, meterstick or metal tape graduated in-increments of 1/16 inch (1 mm).

4.4 Methods cited.

Method 6015, Strength and Elongation, Breaking of Cordage; Spliced Specimen Method

Method 6016, Strength and Elongation, Breaking of Cordage; Non-Spliced Specimen Method

METHOD 6003

5. PROCEDURE

5.1 A load equal to 1 percent of the minimum breaking strength of the cordage being tested shall be applied to the specimen and the machine stopped until the required measurement is taken. The measurement shall be made immediately after application of the required load.

5.1.1 While the specimen is under tension a measuring filament shall be passed around the specimen until it overlaps.

5.1.2 Sufficient tension is applied to the measuring filament to hold it snugly around the specimen and the filament is cut at the point of overlapping. The machine is restarted.

5.1.3 The cut length of the measuring filament shall be laid out on a flat surface, straightened out and measured to the nearest 1/16 inch (1 mm).

5.2 The determination shall be made at the center of the specimen.

6. REPORT

6.1 The average of the circumferences of the specimens tested from a sample unit shall be reported as the circumference of that sample unit and shall be reported to the nearest 1/16 inch (1 mm).

6.2 Each individual value used to calculate the average shall also be reported.

METHOD 6004
July 20, 1978

LENGTH PER UNIT WEIGHT; CORDAGE

1. SCOPE

1.1 This method is intended for determining the length-weight relationship of natural and synthetic fiber cordage.

2. TEST SPECIMEN

2.1 The test specimen size shall be as specified below:

SPECIMEN SIZE

Specimen	<u>Length (minimum)</u>	
	<u>Feet</u>	<u>Meters</u>
Cordage - less than 3 inches (76 mm) in circumference	10	3.0
Cordage - 3 inches (76 mm) to 6 inches (152 mm) inclusive in circumference	5	1.5
Cordage - over 6 inches (152 mm) in circumference	3	0.91

3. NUMBER OF DETERMINATIONS

3.1 Unless otherwise specified in the procurement document, one determination shall be made on each sample unit.

4. APPARATUS

4.1 Tension apparatus. Any suitable device may be used for applying the required load.

4.2 Balance. A balance capable of weighing the specimen to an accuracy of 0.25 percent of the specimen weight.

4.3 Measurement stick or metal tape. Yardstick, meterstick, metal tape or other suitable measuring device graduated in increments of 1/16 inch (1 mm).

5* PROCEDURE

5.1 Care should be exercised in removing the specimen without alteration of the turns in twisted, braided or plaited construction.

FED. TEST METHOD STD. NO. 191A

METHOD 6004

5.2 Tension a suitable length of the cordage with a weight equal to 1 percent of the minimum breaking strength specified for the cordage. The appropriate length as specified in 2.1 shall be marked to the nearest 1/16 inch (1 mm) on the cordage within 2 minutes of the application of tension.

5.3 Relax the tension on the cordage, and cut out the specimen as marked.

5.4 The test specimen shall then be weighed to 0.25 percent of its weight, and the weight "W" recorded.

5.5 Calculation.

5.5.1 Length per unit weight shall be calculated as follows:

$$\frac{L}{W}$$

Where: L = Length of specimen In yards, feet or meters, as applicable.
W = Weight of specimen in pounds or kilograms, as applicable.

6. REPORT

6.1 The length per unit weight shall be reported to the same accuracy as the specified requirement.

METHOD 6010
July 20, 1978

SHRINKAGE OF CORDAGE, BOILING WATER METHOD; DETERMINATION OF

1. SCOPE

1.1 This method is intended for determining the residual shrinkage of cordage.

2. TEST SPECIMEN

2.1 The specimen shall be a length of 24 inches (610 mm) cut from the sample unit.

3. NUMBER OF DETERMINATIONS

3.1 Unless otherwise specified in the procurement document, three determinations shall be made from each sample unit.

4. APPARATUS

4.1 Container. A container of suitable size so that the required specimens can be completely immersed in water when being tested.

4.2 Weights. Weights of suitable size that will cause the specimen to be completely submerged.

4.3 Measurement stick or metal tape. Yardstick, meterstick, metal tape or other suitable measuring device graduated in increments of 1/16 inch (1 urn).

4.4 Marking medium. Pen marker containing water-insoluble ink.

4.5 Whipping twine or tape.

4.6 Oven. Circulating-air oven capable of maintaining the required temperature within $\pm 4^{\circ}\text{F}$ ($+ 2^{\circ}\text{C}$).

5. PROCEDURE

5.1 Unless otherwise specified in the procurement document the specimens shall be brought to equilibrium under Standard Atmospheric Conditions in accordance with Section 4 of this Standard.

5.2 The rope shall be securely whipped or taped at proper intervals prior to cutting to permit the removal of 24 inch (610 mm) specimens without ravening or fraying the ends.

FED. TEST METHOD STD. NO. 191A

METHOD 6010

5.3 The specimen shall be laid out on a flat surface and straightened out, so that there are no twists or turns, and an 18-inch (457 mm) length shall be marked off on the specimen a minimum of 2 inches (51 mm) from either end. It shall be marked with water-insoluble ink or other suitable marking medium.

5.4 The weights shall be attached to the specimen and the whole assembly immersed in boiling water for 15 minutes.

5.5 At the end of the immersion period, the specimen shall be air-dried or dried in a circulating air oven at a temperature not to exceed 185°F (85°C).

5.6 After drying, the specimen shall be returned to equilibrium under Standard Atmospheric Conditions, and the distance between the marks measured for change in length to the nearest 1/16 inch (1 mm).

5.7 Calculations.

5.7.1 The calculation for percent residual shrinkage shall be made as follows:

$$\text{Residual shrinkage, percent} = \frac{18 \text{ inches (457 mm)} - E}{18 \text{ inches (457 mm)}} \times 100$$

Where: E = measurement between marks after immersion in boiling water and return to equilibrium.

6. REPORT

6.1 The residual shrinkage shall be the average of 3 determinations, calculated to the nearest 0.5 percent.

6.2 Each individual value used to calculate the average shall also be reported.

METHOD 6011
July 20, 1978

WATER ABSORPTION; CORDAGE

1. SCOPE

1.1 This method is intended for determining the water absorption of cordage.

2. TEST SPECIMEN

2.1 The test specimen shall be a single length 15 inches (381 mm) long cut from a sample unit.

3. NUMBER OF DETERMINATIONS

3.1 Unless otherwise specified in the procurement document, five specimens shall be tested from each sample unit.

4. APPARATUS

4.1 Tension apparatus. Any suitable device may be used for applying the required load.

4.2 Container. A suitable container in which the test specimen shall be immersed as required.

4.3 Wire rack for drying the specimen during testing.

4.4 Marking medium. Pen marker containing water-insoluble ink.

5. PROCEDURE

5.1 Unless otherwise specified in the procurement document, the specimens shall be brought to equilibrium under Standard Atmospheric Conditions in accordance with Section 4 of this Standard.

5.2 Tension a suitable length of the cordage with a weight equal to 1 percent of the minimum breaking strength specified for the cordage tested, and mark off the required 15 inch (381 mm) specimen length.

5.3 The load is released on the sample unit and the specimen cut out at the marks. A mark is placed 3 inches (76 mm) from each end of the specimen using water-insoluble ink or other suitable marking material.

5.4 The specimen shall be weighed to the nearest 0.1 g.

5.5 The specimen shall be looped, and the loop immersed in a container of distilled water at room temperature until the water surface is level with, but not below or over the marks, so that the cut ends are out of the water.

FED. TEST METHOD STD. NO. 191A

METHOD 6011

5.6 The specimen shall be allowed to steep for 24 hours.

5.7 The specimen shall be removed and cut at the mark, thus removing the cut ends that were not immersed in the water.

5.8 The specimen shall be placed in a draft free area of the conditioned room on a wire rack, care being exercised to prevent shaking or squeezing of the specimen to remove the excess water. The specimen shall be laid horizontally and not touched again until the expiration of the required time for draining. The specimen shall be allowed to drain 1-1/2 hours.

5.9 At the end of the 1-1/2 hour period, the sample shall again be weighed and the amount of water absorption recorded.

5.10 Calculations.

Water absorbed, percent =

$$\frac{(\text{Weight (g) of steeped sample with ends cut}) - 9/15 \text{ of original sample weight (g)}}{9/15 \text{ of original sample weight (g)}} \times 100$$

6. REPORT

6.1 The amount of water absorbed shall be the average of the specimens tested, and shall be reported to the nearest 1.0 percent.

6.2 Each individual value used to calculate the average shall also be reported.

METHOD 6015
July 20, 1978

STRENGTH AND ELONGATION, BREAKING OF CORDAGE;

SPLICED SPECIMEN METHOD

1. SCOPE

1.1 This method is intended for determining the breaking strength and elongation of spliceable cordage.

2. TEST SPECIMEN

2.1 The specimen shall be a single length of the cordage, and shall have an eye splice at each end. The inside length of each eye shall be not less than 7 inches (178 mm) or more than 24 inches (610 mm) with the eye closed. The distance of clear rope between the outer ends of the splices shall not be less than 3 feet (914 mm).

2.1.1 Eye splice on 3-strand twisted cordage (Natural fiber). Eye splices on natural fiber twisted three strand cordage shall be accomplished with a minimum of three full tucks. Tapered splices are permitted (see Figure 6015A).

2.1.2 Eye splice on 3-strand twisted cordage (Synthetic fiber). Eye splices on synthetic fiber twisted three strand cordage shall be accomplished with a minimum of four full tucks. Tapered splices are permitted (see Figure 6015A).

2.1.3 Eye splice on plaited cordage (Synthetic fiber). Eye splices on synthetic fiber plaited cordage shall be accomplished with a minimum of two double folds and two singles (see Figure 6015B).

2.1.4 Eye splice on hollow braided cords. Eye splices on hollow braided cordage shall be accomplished with a tapered buried eye splice. The taper shall consist of cutting out-every fifth pick-in right and left-strands for 16, 24, and 32 strand round braids and alternately fourth and fifth picks for 20 strand braid (see Figure 6015C).

3. NUMBER OF DETERMINATIONS

3.1 Unless otherwise specified in the procurement document, the number of determinations shall be as follows:

Rope with a circumference up to and including 5 inches (127 mm):
3 specimens shall be tested from each sample unit.

Rope with a circumference over 5 inches (127 nun):
2 specimens shall be tested from each sample unit.

FED. TEST METHOD STD. NO. 191A

METHOD 6015

4. APPARATUS

4.1 Testing machine. The testing machine shall consist of three main parts:

- (a) Straining mechanism.
- (b) Means for holding the specimen.
- (c) Load indicating mechanism.

4.1.1 Straining mechanism. The straining mechanism shall be such that the movement of the pulling clamp shall be uniform at a rate of 6 ± 1 inches (152 ± 25 mm) per minute under no load. The distance between the clamps is arbitrary.

4.1.2 Specimen holders. The means for holding the specimen during testing shall consist of round metal pins or posts. The pins or posts shall be of sufficient size and held in any manner that will assure breaking of the specimen in the free length.

4.1.3 Load indicating mechanism. The load indicating mechanism shall be a calibrated dial, scale or chart for indicating the applied load. Unless otherwise specified for load determination, the mechanism shall be adjusted or set so that the maximum load required to break the specimen will remain on the dial, scale or chart after the specimen is ruptured.

4.1.4 The test machine shall be of such capacity that the maximum load required to break the specimens shall not be greater than 85 percent or less than 15 percent of the rated capacity.

4.1.5 Measuring scale. Yardstick, meterstick, or metal tape graduated in increments of $1/8$ inch (1 mm), for use in applying gage marks to the specimen, and for measuring between the marks to determine elongation.

5. PROCEDURE

5.1 Preparation of specimen. Unless otherwise specified in the procurement document, the specimen shall be conditioned and tested under Standard Atmospheric Conditions in accordance with Section 4 of this Standard.

5.1.1 When elongation of the specimen is to be determined a load equal to 1 percent of the specified minimum breaking strength shall be applied to the specimen. While under tension, two fine gage marks shall be spaced 30 inches (762 mm) apart on the specimen in such a manner that neither mark will be closer than 3 inches (76 mm) to the inner end of either splice.

5.1.2 If soaking of the splices is required, (this requirement applies to specimens of cordage made from jute, sisal, manila, henequen and other hard fiber ropes) the eyes and splices up to the inner ends of the splices shall be immersed in water for a minimum of 15 minutes. Gage marks if required for determining elongation shall be placed on the specimens before soaking.

METHOD 6015

5.2 Elongation. Elongation shall be determined during the determination of the breaking strength of the specimen. It shall be measured when the load applied during the test is 75 percent of the specified minimum breaking strength of the specimen being tested.

5.2.1 When the specimen is pulled to 75 percent of the specified minimum breaking strength, the machine may be stopped and the distance "E" between the gage marks on the specimen measured and recorded. The distance between the marks shall be measured to the nearest 1/8 inch (1 mm).

5.3 Breaking strength. If the machine has been stopped for determination of elongation after the distance between the marks has been measured the machine shall be restarted and the load increased until the specimen breaks.

5.3.1 If the splices are noticed to be slipping and the individual measurement falls markedly below the apparent average such a measurement shall be disregarded and another specimen shall be tested from the same sample unit.

5.4 Calculations. The elongation shall be calculated as follows:

$$\text{Elongation, percent} = \frac{E - O}{O} \times 100$$

Where: E = The distance in inches (mm) between gage marks at 75 percent of the specified minimum breaking strength.
 O = The distance in inches (mm) between the gage marks at 1 percent of the specified minimum breaking strength (see 5.1.1).

6. REPORT

6.1 Breaking strength. The breaking strength of the sample unit shall be the average of the specimens tested and shall be reported as follows:

<u>Cordage Breaking Strength</u>	Reported to Nearest
0 to 150 lbs (0 to 670 N)	1 lb (1 N)
151 to 2000 lbs (671 to 8900 N)	5 lbs (10 N)
2001 to 50,000 lbs (8901 to 222,500 N)	10 lbs (100 N)
50,000 lbs and up (222,501 and up)	100 lbs (1000 N)

6.2 Elongation. The elongation of the sample unit shall be the average of the specimens tested and shall be reported to the nearest 0.5 percent.

6.3 Each individual value used to calculate the average shall also be reported.

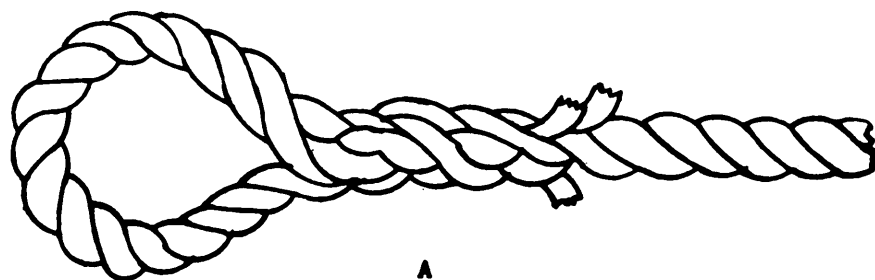

EYE SPLICE ON 3-STRAND TWISTED CORDAGE

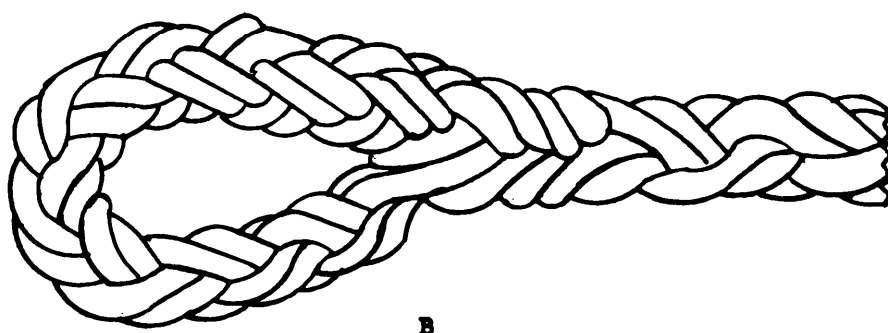

EYE SPLICE ON PLAITED CORDAGE

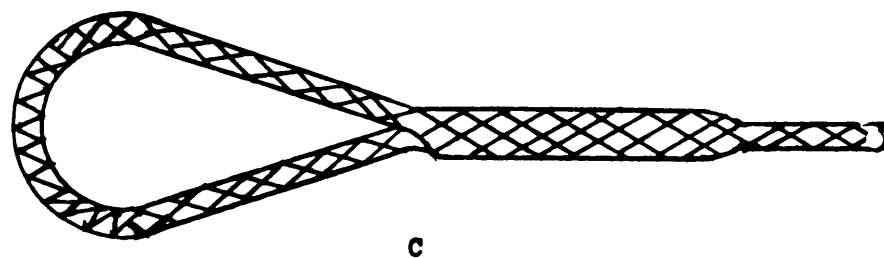

EYE SPLICE ON BRAIDED CORDAGE

FIGURE 6015

METHOD 6016
July 20, 1978

STRENGTH AND ELONGATION BREAKING OF CORDAGE; NON-SPLICED SPECIMEN METHOD

1. SCOPE

1.1 This method is intended for determining the breaking strength and elongation of cordage that does not require eye-splices to be tested.

2. TEST SPECIMEN

2.1 The specimen shall be a single length of the finished cordage not less than 24 inches (610 mm) long.

3. NUMBER OF DETERMINATIONS

3.1 Unless otherwise specified in the procurement document, five specimens shall be tested from each sample unit.

4. APPARATUS AND METHODS CITED

4.1 Apparatus.

4.1.1 The apparatus for determining the breaking strength and elongation shall be as described in Method 5100, except that the flat clamps shall be replaced with smooth clamps of the spool or drum type and the speed of the machine before the application of a load to the specimen shall be 6 ± 1 inches per minute (152 ± 25 mm/min).

4.1.2 Ink marker. Ink marker for marking specimen to determine elongation.

4.1.3 Scale and dividers. A pair of dividers opening a distance not less than 12 inches (305 mm) and a scale graduated in divisions of 0.01 inch (0.3 mm).

4.2 Method cited.

Method 5100, Strength and Elongation, Breaking of Woven Cloth;
Grab Method.

5. PROCEDURE

5.1 Preparation of specimen. Unless otherwise specified in the procurement document material testing shall be performed under Standard Conditions as specified in Section 4 of this Standard.

FED. TEST METHOD STD. NO. 191A

METHOD 6016

5.1.1 The distance between the clamps or drums (gage length) at the start of the test shall be 10 inches (254 mm).

5.1.2 The specimen shall be placed in the clamps or drums of the machine and a load applied equal to 1 percent of the specified minimum breaking strength of the specimen being tested. The machine shall be stopped and the strain maintained on the specimen.

5.1.3 While the strain is being maintained on the specimen two fine ink marks shall be spaced 5 inches (127 mm) apart and neither mark shall be placed closer than 1-1/2 inches (38 mm) to either clamp or drum.

5.1.4 The machine shall be restarted and the testing continued to completion.

5.2 Elongation. Elongation shall be measured during the determination of the breaking strength of the specimen. It shall be measured when the load applied during the test is 75 percent of the specified minimum breaking strength of the cordage being tested.

5.2.1 When the specimen is pulled to 75 percent of the minimum breaking strength of the cordage being tested, the machine may be stopped and the distance between the two fine marks on the specimen is measured and recorded. The distance "E", in inches (mm), between the marks shall be measured to the nearest 0.05 inch (1.3 mm).

5.3 Breaking strength. If the machine is stopped to measure the elongation it shall be restarted and the load increased until the specimen ruptures.

5.3.1 If a specimen slips between the jaws, breaks in the jaws or for any reason of machine malfunction an individual measurement falls markedly below the apparent average test results, such a measurement shall be disregarded and another specimen shall be tested from the same sample unit.

5.4 Calculation.

5.4.1 The elongation shall be calculated as follows:

$$\text{Elongation, percent} = \frac{E - 5 \text{ inches (127 mm)}}{5 \text{ inches (127 mm)}} \times 100$$

Where E = Distance between the marks, in inches (mm), when the load is 75 percent of the specified minimum breaking strength of the cordage being tested.

6. REPORT

6.1 The elongation shall be the average of the specimens tested and reported to the nearest 0.1 percent.

METHOD 6016

6.2 The breaking strength shall be the average of the specimens tested and shall be reported to an accuracy of 0.5 percent of the indicated (recorded) breaking strength.

6.3 Each individual value used to calculate the average (for elongation and breaking strength) shall also be reported.

METHOD 6020
July 20, 1978

HARDNESS; CORDAGE

1. SCOPE

1.1 This method is intended for determining the hardness of twisted and plaited cordage.

2. TEST SPECIMEN

2.1 Unless otherwise specified in the procurement document, the test specimen shall be a minimum of 20 feet (6.1 m).

3. NUMBER OF DETERMINATIONS

3.1 Unless otherwise specified in the procurement document, one specimen shall be taken from each sample unit and 3 determinations shall be made on each specimen.

4. APPARATUS

4.1 Compression testing machine. The machine shall be capable of maintaining a loading rate of 6 inches \pm 1 inch (152 mm \pm 25 mm) per minute. The machine shall be equipped with a suitable autographic recording device or other suitable means for measuring hardness to a maximum of 100 pounds (445 N).

4.2 Pressure plate. The diameter (inches) (mm) of the orifice in the pressure plate through which the spike passes after being forced through the specimen being tested shall be approximately twice the diameter of the specimen being tested but not less than 1/2 inch (13 mm) (see figure 6020B and paragraph 7.1).

4.3 Spike. The spike shall conform to the requirement as shown in figure 6020A.

5. PROCEDURE

5.1 The spike inserted in the rope shall be placed in the compression testing machine in such a manner that the force necessary to push the spike through the rope will be measured with the rope in the relaxed state, without tension and completely free to absorb the force of the penetrating spike (see figure 6020C and paragraph 7.1). The spike shall be inserted between the strands of the rope until visible on the opposite side, and shall be not less than 5 feet (1.5 m) from a cut end (which will be securely sewed or taped to prevent unlaying), and not less than 5 feet (1.5 m) from any area subjected to a previous hardness test. Rate of loading shall be 6 inches \pm 1 inch (152 mm \pm 25 mm) per minute. The load necessary to force the spike to 1/2 inch (13 mm) diameter shall be measured on cordage up to and including 2-3/4 inches (70 mm) in circumference. The load necessary to force the spike to the 1 inch (25 mm) diameter mark shall be measured on cordage greater than 2-3/4 inches (70 mm) circumference. The 1/2 inch (13 mm) and 1 inch (25 mm) marks shall be considered to be reached when the mark disappears behind the strand.

FED. TEST METHOD STD. No. 191A

METHOD 6020

5.1.1 When a specimen of plaited cordage is tested the spike shall be inserted through the center of the specimen so that two pairs of strands are on each side of the spike.

5.2 Readings of the hardness measurements resulting from the spike, together with the rope specimen being forced through the orifice and/or binding within the orifice, shall be recorded.

6. REPORT

6.1 The hardness of each specimen shall be the average of 3 determinations, and shall be reported to the nearest 1 pound (to the nearest 1 N).

6.2 Each individual value used to calculate the average shall also be reported.

7. NOTES

7.1 Figures 6020B and 6020C are included as information to the contractor to illustrate the procedure for conducting the test.

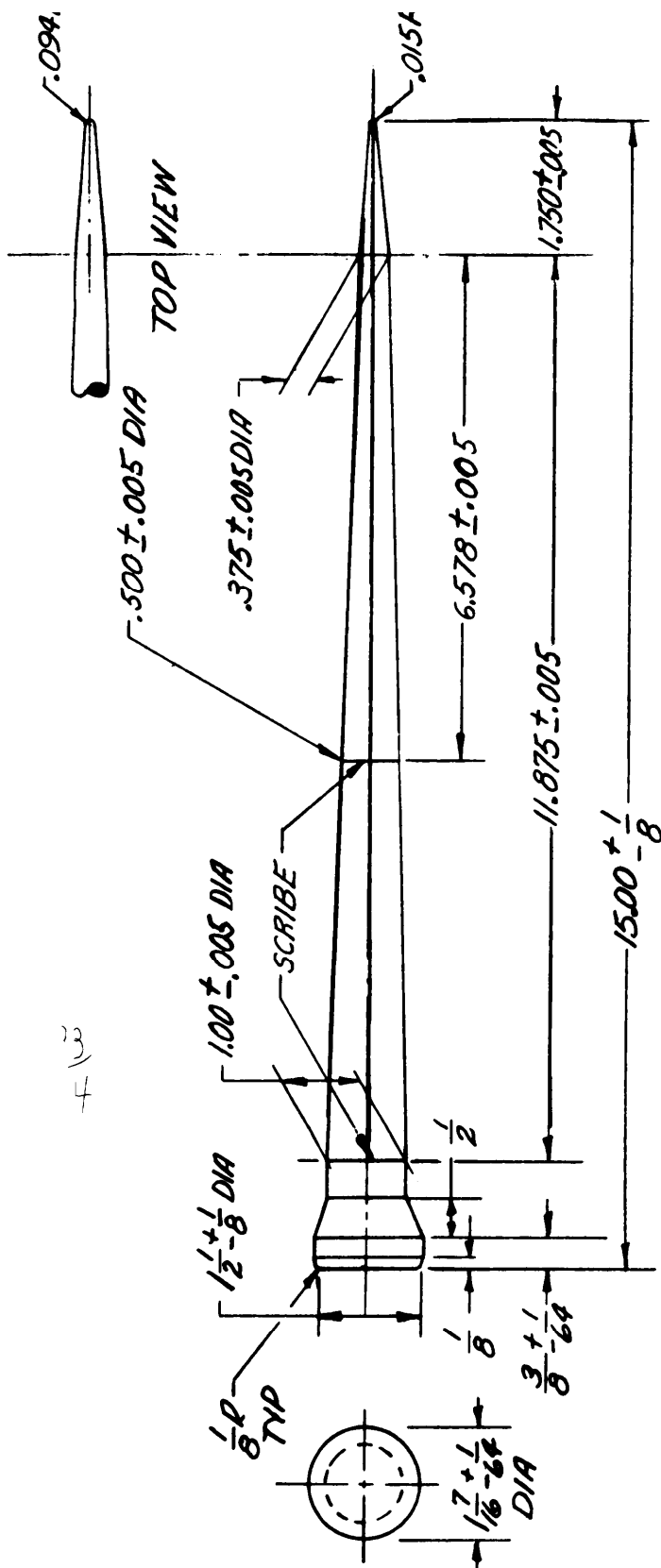

FIG. 6020 A TESTING DEVICE FOR HARDNESS OF ROPE (SPIKE)

NOTES:

1. MATERIAL: CARBON TOOL STEEL
2. FINISH: SMOOTHLY FINISHED AND POLISHED OVER THE ENTIRE WORKING AREA
3. GRIND ALL OVER
4. HARDEN'S DRAW - SEE MATERIAL
5. ALL DECIMAL DIMENSIONS ARE MANDATORY, ALL FRACTIONAL DIMENSIONS ARE TO BE USED AS A GUIDE

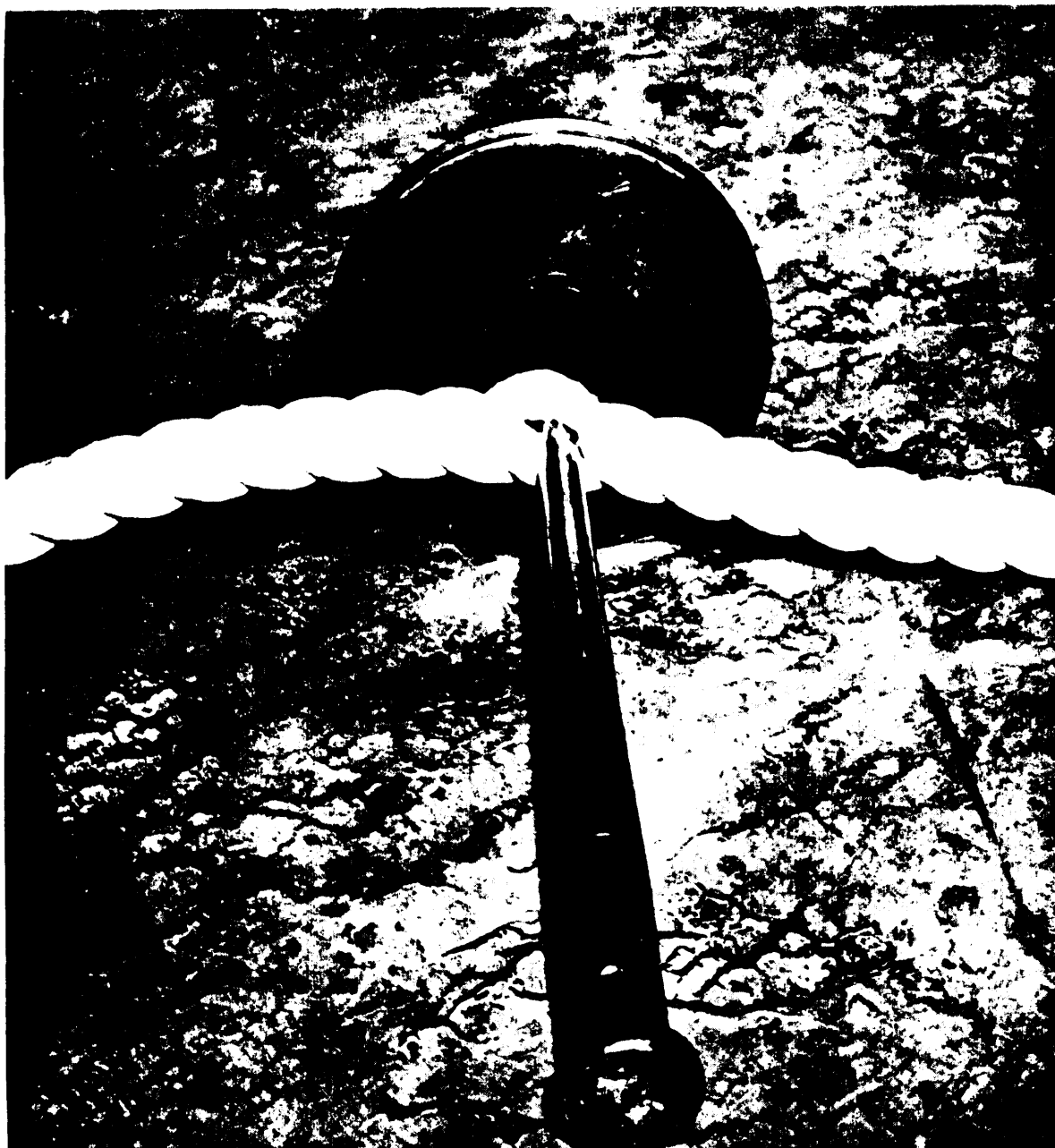

Figure 6020B

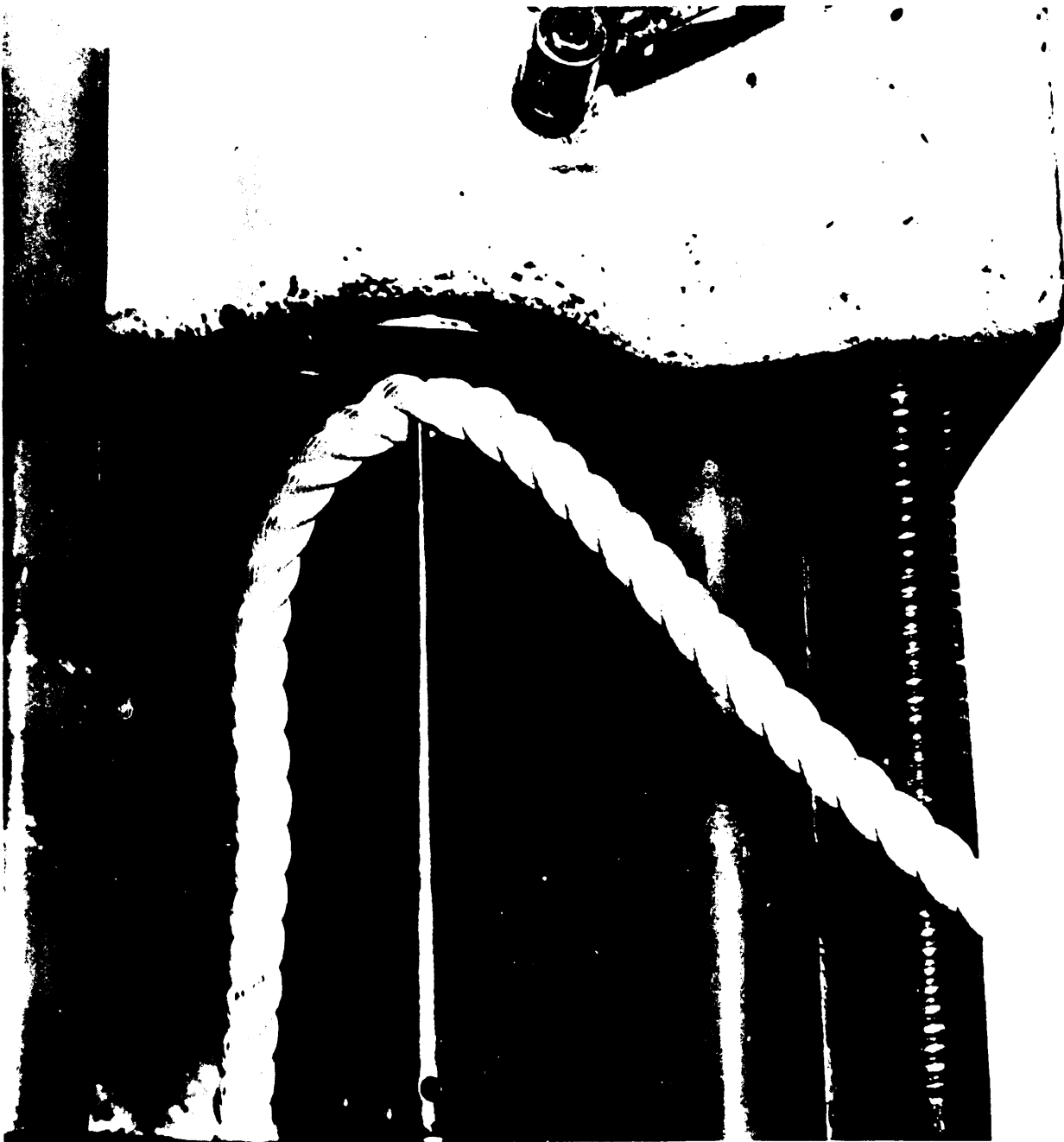

Figure 6020C

METHOD 7102
July 20, 1978

GRIPPING STRENGTH OF SHOE LACE TIPS

1. SCOPE

1.1 This method is intended for determining the gripping strength of the shoe lace tip; i.e., the resistance offered by the tip to its complete removal from the shoe lace.

2. TEST SPECIMEN

2.1 Unless otherwise specified in the procurement document, the test specimen shall be a one-half length of the shoe lace. Two specimens may be made from one complete shoe lace.

3. NUMBER OF DETERMINATIONS

3.1 Unless otherwise specified in the procurement document, 10 specimens shall be tested from each sample unit,

4. APPARATUS AND METHOD CITED

4.1 Apparatus.

4.1.1 A testing machine as described in Method 5100, except a slotted metal plate (see Figure 7102) shall be used in conduction with the top jaw-assembly. The lower jaw-assembly shall be as described in Test Method 5100.

4.1.2 A rigid metal plate 5 inches by 1.5 inches (127 mm by 38 mm), approximately 1/8 Inch (3 mm) thick, having a 4 inch (102 mm) tapered slot, centered width-wise and running lengthwise from an Inside dimension of 1/32 inch (0.80 mm) in width, increasing to a width of 1/4 inch (6 mm) at the outside edge. The slot shall be smoothly finished, The plate shall rest on top of the slightly open top jaw facings in such a manner that the slot of the plate is directly above the open jaws and centered so that the plate in a horizontal position is balanced by the top jaw assembly.

4.2 Method cited.

4.2.1 Method 5100, Strength and Elongation, Breaking of Woven Cloth; Grab Method.

5. PROCEDURE

5.1 The distance between the top jaw (slotted metal plate) and the lower jaws shall be 4 inches (102 mm).

METHOD 7102

5.2 With the slot of the metal plate centered over the slightly open top jaw facings, slip the lace into the slot as far as it will go, so that the inside edge of the tip is in contact with the top of the plate.

5.3 Align the plate so that the specimen is approximately in the middle of the lengthwise direction of the jaws.

5.4 The free end of the specimen shall be fastened in the lower jaws.

5.5 Force shall be applied to the specimen at such a rate that the pulling clamp will have a uniform speed of 12 ± 0.5 inches per minute (305 ± 13 mm/min).

5.6 Start the tester, with the pawl in contact with the ratchet, and the maximum resistance in displacing the tip shall be recorded.

5.7 If the lace tip slips through the slot without its being removed from the lace or if for any reason attributed to faulty technique, an individual measurement falls markedly below the average of the sample unit, such results shall be discarded and another specimen shall be tested.

5.8 Buckling of the tip material at the base of the tip or peeling back without the tip being removed from the lace shall not be considered as a failure and the result shall be discarded and another specimen shall be tested.

6. REPORT

6.1 The gripping strength of the sample unit shall be the average of the specimens tested from the sample unit and shall be reported to the nearest 1 pound (to the nearest 1 N).

6.2 Each individual value used to calculate the average shall also be reported.

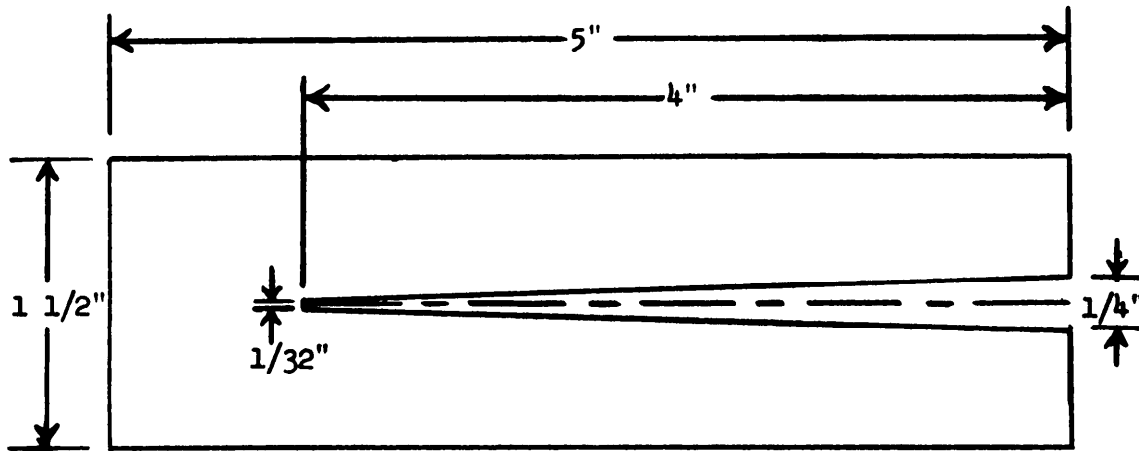

FIGURE 7102 - slotted Metal Plate

METHOD 7308
July 20, 1978

ABRASION RESISTANCE; SOCKS, HOSIERY, AND KNITTED CLOTH:

UNIFORM-ABRASION (SCHIEFER) METHOD

1. SCOPE

1.1 This method is intended for determining the resistance to abrasion of dry and wet specimens of the heel, toe, and sole of socks and hosiery and of knitted cloth. It is applicable to products which vary in fiber content, construction, finishing treatment, and kind and amount of auxiliary substances.

2. TEST SPECIMEN

2.1 The toe or heel portion of the sock or hosiery, or a circle of knitted cloth cut with a metal die 2.4126 inches (61.3 mm) in diameter, or as specified in the procurement document.

3. NUMBER OF DETERMINATIONS

3.1 Unless otherwise specified in the procurement document, 10 specimens shall be tested from each sample unit.

4. APPARATUS AND METHOD CITED

4.1 Apparatus.

4.1.1 Abrasion machine (see 7.1) An abrasion machine and accessories described in Method 5308), except for the clamp assembly which shall be as follows:

4.1.1.1 Clamp assembly. A clamp assembly for holding knitted specimen as shown in figure 7308.

4.1.1.1.1 Tensioning base. A tensioning base, "A" (see figure 7308).

4.1.1.1.2 Clamp base. A clamp base, "B" (see figure 7308), attachable to tensioning base.

4.1.1.1.3 Pressure ring. A pressure ring, "C" (see figure 7308), mounted on top of specimen resting on clamp base.

FED. TEST METHOD STD. NO. 191A

METHOD 7308

4.1.1.1.4 Outer ring. An outer ring, "D" (see figure 7308), screwed on the clamp base over the pressure ring to hold the specimen securely.

4.1.1.1.5 Tension weights. Two 2-1/2 pounds (1.1 kg) or other tension weights, as specified, to fit on tensioning base.

4.2 Method cited.

Method 5308, Abrasion Resistance of Cloth; Uniform Abrasion (Schiefer) Method.

5. PROCEDURE

5.1 Unless otherwise specified in the procurement document, the procedure shall be as described in Method 5308.

6. REPORT

6.1 Unless otherwise specified in the procurement document, the report shall be as described in Method 5308.

7. NOTES

7.1 An abrasion machine of the type described in this method is manufactured by Frazier Precision Instrument Company, Inc., 210 Oakmont Avenue, Gaithersburg, MD 20760.

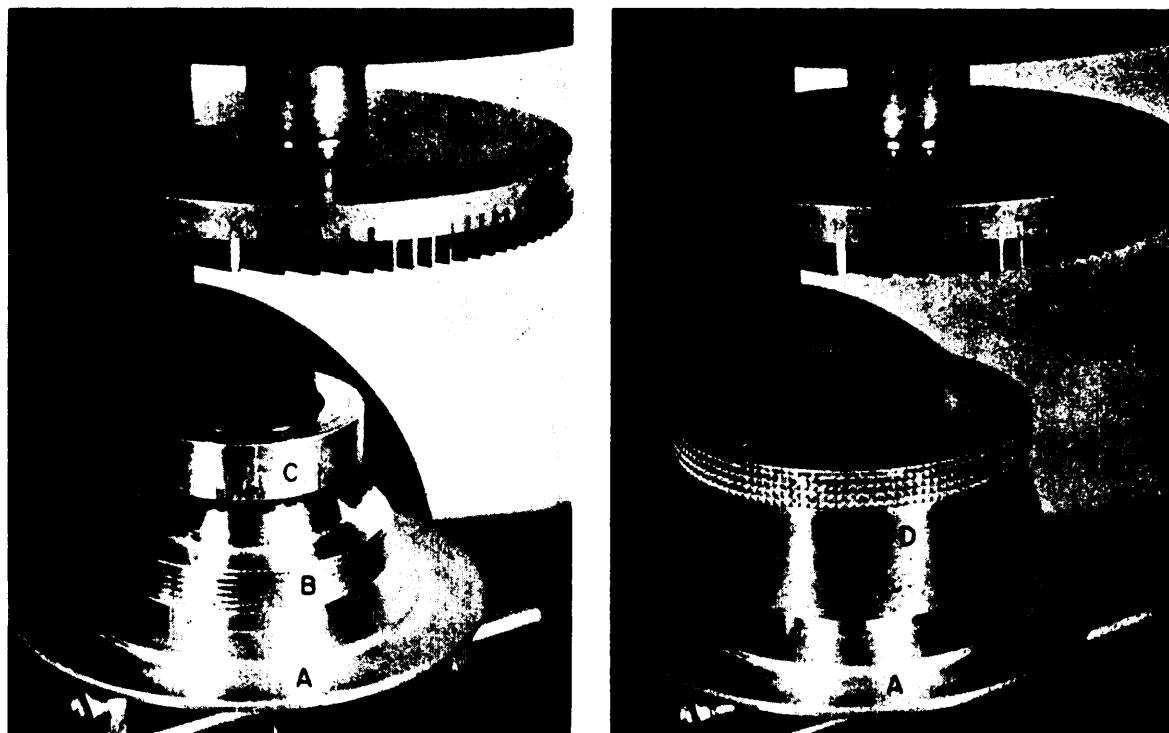

- A. Tensioning base
- B. Clamp base
- C. Pressure ring
- D. Outer ring

FIGURE 7308 - ABRASION TESTER

METHOD 7540
July 20, 1978

STRETCHED WIDTH OF KNIT ITEMS

1. SCOPE

1.1 This method is intended for determining the stretched width of knit items. It is especially applicable for socks and knit inserts.

2. TEST SPECIMEN

2.1 Unless otherwise specified in the procurement document, the specimen shall be one completed end item.

3. NUMBER OF DETERMINATIONS

3.1 Unless otherwise specified in the procurement document, five specimens from each sample unit shall be tested.

4. APPARATUS

4.1 Houchin modification of the Schiefer measuring device (see 7.1 and Figure 7540).

4.1.1 The apparatus consists of a rectangular metal separating form measuring 2 inches by 4 inches (51 mm x 102 mm) over which the specimen is drawn, so constructed that the top section slides freely out of the bottom section. This form shall be fixed in front of an upright arm bearing a scale graduated in divisions of 0.1 inch (1 mm) and shall have a freely rotating pulley at the top. An indicator consisting of a pointer pin (see 7.2), which is inserted through the specimen and the hole in the top sliding section of the form, shall be provided. This indicator shall be attached by means of a cord which passes over the specimen under tension of a specified weight by its position against the graduated scale on the instrument upright.

4.1.2 Stop watch.

4.1.3 Ruler or measurement stick. Ruler or any other suitable measuring device graduated to 0.1 inch (1 mm).

5. PROCEDURE

5.1 Unless otherwise specified in the procurement document, the specimens shall be conditioned and tested under Standard Atmospheric Conditions in accordance with Section 4 of this Standard.

FED. TEST METHOD STD. NO. 191A

METHOD 7540

5.2 The specimen shall be pulled over the metal form so that the midpoint of the area of test is aligned with the hole in the top sliding section of the form. The specimen shall be parallel to the 2-inch (51 mm) edges of the separating form.

5.3 The indicator pin shall be inserted through the specimen and the hole in the top sliding section of the form.

5.4 The weight, as specified in the procurement document, shall be slowly applied so as to cause separation of the top and bottom sections of the form with resultant stretch of the specimen. The weight shall be allowed to hang freely for the length of time specified in the procurement document. This time shall be measured by means of a stop watch.

5.5 When the specified time has elapsed, immediately record the indicated reading from the graduated scale (the stretched width of the specimen), and remove the weight. The specimen shall then be removed from the metal form.

5.6 When the amount of unrecovered stretch is a requirement the following shall apply:

5.6.1 Original width of specimen. Before the specimen is put on the form the specimen shall be laid on a flat, horizontal surface in a tensionless reamer. The item shall be measured with the ruler at its center to the nearest 0.1 inch (1 mm). This measurement shall be reported as the original width, "O".

5.6.2 Width of specimen after stretching. When the specimen is taken off the form, after having been stretched for the specified time and load, the specimen shall immediately be laid on a flat, horizontal surface in a tensionless manner and measured as described in 5.6.1. This measurement shall be reported as the width after stretching, "S".

5.6.3 Calculation of unrecovered stretch:

$$\text{Unrecovered stretch, inches (mm)} = S - O$$

Where:

O = Original width of specimen, in inches (mm)

S = Width of specimen after stretching, in inches (mm)

6. REPORT

6.1 The stretched width of the sample unit shall be the average of the results obtained from the specimens tested and shall be reported to the nearest 0.1 inch (1 mm).

6.2 The unrecovered stretch of the sample unit shall be the average of the results obtained from the specimens tested and shall be reported to the nearest 0.1 inch (1 mm).

6.3 Each individual value used to calculate the average shall also be reported.

7. NOTES

7.1 The Houchin modification of the Schiefer measuring device may be obtained from Frazier Precision Instrument Co., Inc., 210 Oakmont Ave., Gaithersburg, MD 20760.

7.2 Under certain circumstances the pointer pin may slip from the hole in the top sliding section thus creating a safety hazard. Safety glasses should be worn while performing this test.

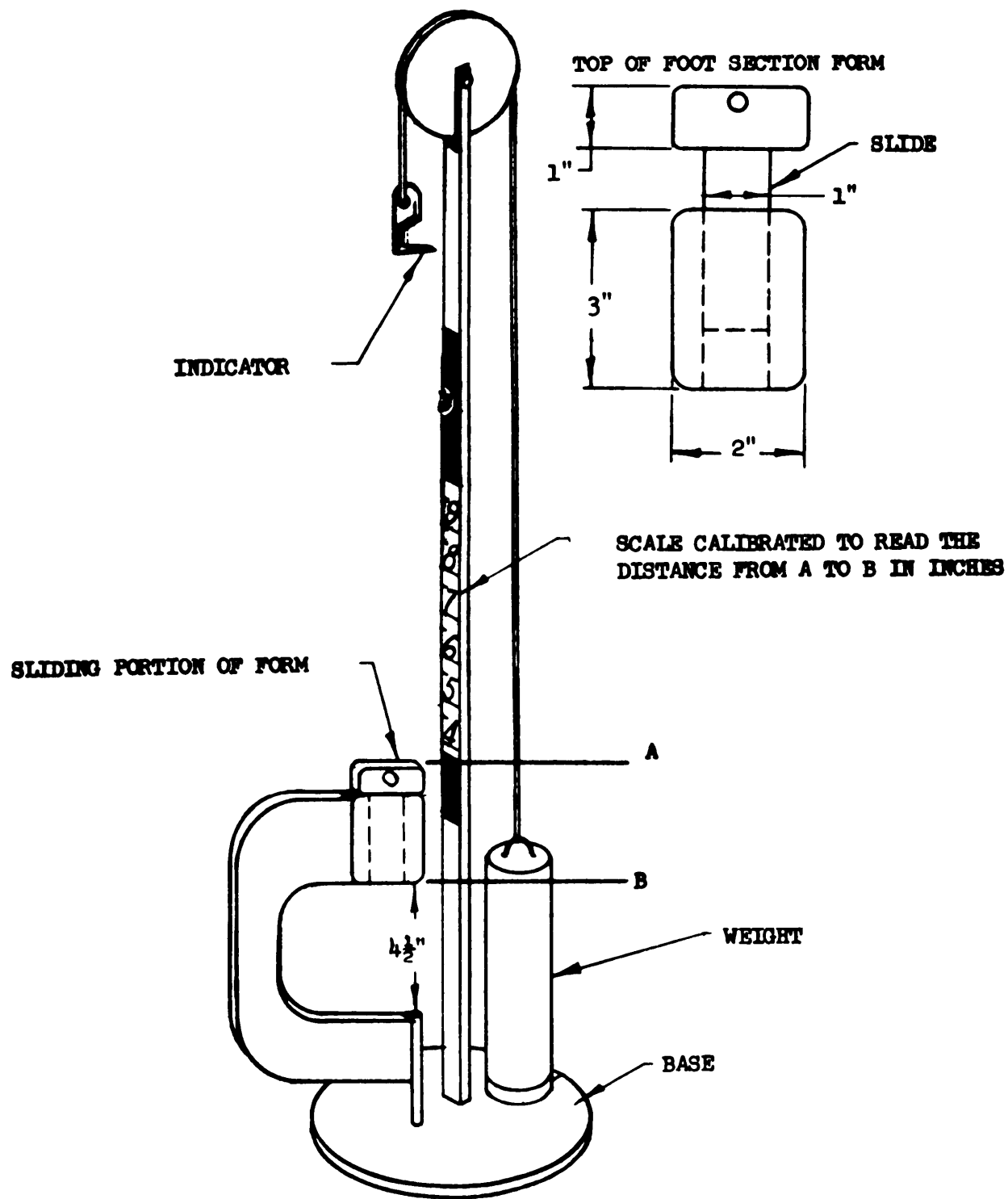

FIGURE 7540- HOUCHIN MODIFICATION OF SCHIEFER MEASURING DEVICE

METHOD 7550
July 20, 1978

SHRINKAGE IN LAUNDERING OF COTTON AND LINEN GARMENTS AND
READY-MADE ARTICLES

1. SCOPE

1.1 This method is intended for determining the shrinkage of woven cotton and linen garments and ready-made articles when subjected to a normal laundering procedure. It may be used for some knitted garments. Shrinkage in laundering is the change in measured distances due to laundering.

2. TEST SPECIMEN

2.1 The specimen shall consist of the complete garment or ready-made article prepared as follows:

2.1.1 The garment or ready-made article shall be laid out without tension on a flat surface. Care shall be taken that it is free from wrinkles and creases. When necessary, the dimension shall be marked with indelible ink and a fine-pointed pen, or by sewing threads into the fabric.

2.1.2 Unless otherwise specified in the procurement document, the dimensions applicable to the specimen shall be measured as follows:

2.1.2.1 Neckband or collarband. Distance from outside end of one buttonhole inside of band to outside end of other buttonhole, or to center of button, with neckband laid out flat.

2.1.2.2 Chest or bust. Twice the distance across buttoned-up garment approximately 1 inch (25 mm) below armhole, measured with the garment folded back to back and front to front with underarm seams together.

2.1.2.3 Front or back length (skirt, blouse, or coat). Distance from the highest part of the yoke or top of shoulder seam to the bottom of the garment.

2.1.2.4 Armhole, width. Distance from point of shoulder or top of armhole measured around the armhole to the lowest point under arm, or lower edge of opening (slips, union suits, or equivalent).

2.1.2.5 Sleeve, length. Distance from point where sleeve is attached to shoulder to upper outside edge of cuff or to sleeve bottom, except that measurements on men's dress shirts shall be made from the center of yoke at neckband to upper outside edge of cuff.

FED. TEST METHOD STD. NO. 191A

METHOD 7550

2.1.2.6 Hips (garments with waistband or equivalent). Twice the distance across the hips 8 inches (203 mm) below the waist, measured with the garment folded back to back and front to front with side seams together.

2.1.2.7 Hips (slips or equivalent). Twice the distance across the garment 17-1/2 inches (445 mm) down from top of body of garment for strap type, and 24 inches (610 mm) down from top of-shoulder for built-up type, measured with the garment folded back to back and front to front with the underarm seams together.

2.1.2.8 Front rise (pants and shorts). Distance from bottom of crotch, not including width of seam, up front of buttoned or zippered garment to middle of front edge of waistband.

2.1.2.9 Back rise (pants and shorts). Distance from bottom of crotch, not including width of seam, up back of buttoned or zippered garment to middle of back edge of waistband.

2.1.2.10 Inseam, width (pants, pajamas, shorts). Distance from inside corner of one leg to other leg, with pants legs spread and inseam stretched in straight line.

2.1.2.11 Length (pants and shorts), total. Distance from top of outseam or outside edge of waistband to lower edge of outseam or leg.

2.1.2.12 Length (one-piece dress, slips, union suits, or equivalent) total. Distance from highest point of shoulder for built-up type or top of body of garment for strap type to bottom edge of garment.

2.1.2.13 Length (skirts), total. Distance from outside edge of waistband or waist seam, center front, to lower edge of skirt bottom.

3. NUMBER OF DETERMINATIONS

3.1 Unless otherwise specified in the procurement document, three specimens shall be tested from each sample unit.

4. APPARATUS AND METHOD CITED

4.1 Apparatus.

4.1.1 The apparatus shall be as described in Method 5550.

4.2 Method cited.

Method 5550, Shrinkage in Laundering; Cotton, Linen and Blended Cotton and Linen Cloth

METHOD 7550

5. PROCEDURE

5.1 The procedure shall be as described in Method 5550, except that the results shall be calculated as follows:

$$\text{Shrinkage, percent} = \frac{\text{Initial measurement} - \text{Measurement after laundering}}{\text{Initial measurement}} \times 100$$

6. REPORT

6.1 The shrinkage of the sample unit shall be the average of the specimens tested, and each dimension shall be reported separately to the nearest 0.1 percent.

6.2 Each individual value used to calculate the average shall also be reported.

METHOD 7552
July 20, 1978

SHRINKAGE IN LAUNDERING OF GARMENTS AND READY-MADE

ARTICLES OTHER THAN COTTON AND LINEN

1. SCOPE

1.1 This method is intended for determining the shrinkage of woven garments and ready-made articles containing fibers other than cotton or linen or mixtures of either cotton or linen and other fibers, when subjected to a normal laundering procedure. It may be used for some knitted garments. Shrinkage in laundering is the change in measured distances due to laundering.

2. TEST SPECIMEN

2.1 The specimen shall be the complete garment or ready-made article prepared as described in Method 7550.

3. NUMBER OF DETERMINATIONS

3.1 Unless otherwise specified in the procurement document, three specimens shall be tested from each sample unit.

4. APPARATUS AND METHODS CITED

4.1 Apparatus.

4.1.1 The apparatus shall be as described in Method 5550.

4.2 Methods cited.

Method 5550, Shrinkage in Laundering; Cotton, Linen and Blended Cotton
Cloth

Method 5552, Shrinkage in Laundering; Cloth Other than Cotton and Linen

Method 7550, Shrinkage in Laundering of Cotton and Linen Garments and
Ready-Made Articles

5. PROCEDURE

5.1 The procedure shall be as described in Method 5552 except for the following:

5.1.1 Pressing. The specimen shall be pressed as described in Method 5550.

5.1.2 Dimensional measurement. The pressed specimen shall be measured as described in Method 7550.

FED. TEST METHOD STD. NO. 191A

METHOD 7552

5.1.3 Calculation of results. Shrinkage shall be calculated as follows:

$$\text{Shrinkage, percent} = \frac{\text{Initial measurement} - \text{Measurement after laundering}}{\text{Initial measurement}} \times 100$$

6. REPORT

6.1 The shrinkage of the sample unit shall be the average of the specimens tested, and each dimension shall be reported separately to the nearest 0.1 percent.

6.2 Each individual value used to calculate the average shall also be reported.

SHRINKAGE IN LAUNDERING OF WOOL GARMENTS AND READY-MADE ARTICLES;
ACCELERATED METHOD

1. SCOPE

1.1 This method is intended for determining the shrinkage in laundering of woven or knitted shrink-resistant wool garments and articles by means of an accelerated procedure. It is much more severe than Methods 7552, 7556, and 7560, and is especially useful in determining by one test the shrinkage equivalent of a number of normal launderings. The article may or may not be relaxed prior to this test as required by the procurement document. (See relaxation method 7558.) Shrinkage in laundering is the change in measured distances due to laundering.

2. TEST SPECIMEN

2.1 The specimen shall be the complete garment or article prepared as described in Method 7550.

3. NUMBER OF DETERMINATIONS

3.1 Unless otherwise specified in the procurement document, three specimens shall be tested from each sample unit.

4. APPARATUS AND METHODS CITED

4.1 Apparatus

4.1.1 Wash wheel. Wash wheel as described in Method 5550.

4.1.2 Extractor. Extractor as described in Method 5550.

4.1.3 Drier. Drier as described in Method 5556, except that it shall be provided with means of maintaining a stack temperature of $130^{\circ} \pm 2^{\circ}\text{F}$ ($54^{\circ} \pm 1^{\circ}\text{C}$).

4.1.4 Pressing equipment as described in Method 7556, except that it shall be equipped to maintain the temperature between 248° to 302°F (120° and 150°C).

4.1.5 Measuring scale. Measuring scale as described in Method 5550.

4.1.6 Water. A source of water at a temperature of $60^{\circ} \pm 2^{\circ}\text{F}$ ($16^{\circ} \pm 1^{\circ}\text{C}$), and of not over 50 parts per million hardness.

4.1.7 Buffering agent. A buffering agent for buffering the water to a pH of approximately 7.0.

METHOD 7554

4.2 Methods cited.

Method 5550, Shrinkage In Laundering; Cotton, Linen, and Blended Cotton and Linen Cloth

Method 5554, Shrinkage in Laundering; Wool Cloth; Accelerated

Method 5556, Mobile Laundry Evaluation for Textile Materials

Method 7550, Shrinkage In Laundering of Cotton and Linen Garments and Ready-Made Articles

Method 7556, Shrinkage in Laundering of Garments and Ready-Made Articles; Mobile Laundry Method

5. PROCEDURE

5.1 The procedure shall be as described in Method 5554, except for the following:

5.1.1 Pressing. After drying, the specimen shall be pressed as described in Method 5550 except that the temperature shall be 248° to 302°F (120° to 150°C).

5.1.2 Dimensional measurement. The pressed specimen shall be measured as described in Method 7550.

5.1.3 Calculation of results. Shrinkage shall be calculated as follows:

$$\text{Shrinkage, percent} = \frac{\text{Initial measurement} - \text{Measurement after laundering}}{\text{Initial measurement}} \times 100$$

6. REPORT

6.1 The shrinkage of the sample unit shall be the average of the specimens tested, and each dimension shall be reported separately to the nearest 0.1 percent.

6.2 Each individual value used to calculate the average shall also be reported.

METHOD 7556
July 20, 1978

SHRINKAGE IN LAUNDERING OF GARMENTS AND READY-MADE ARTICLES;

MOBILE LAUNDRY METHOD

1. SCOPE

1.1 This method is intended for use where it is desired to reproduce by means of a laboratory procedure changes in dimensions of woven or knitted garments, felting of wool, etc., induced by laundering under Army field conditions. Shrinkage in laundering is the change in measured distances due to laundering.

2. TEST SPECIMEN

2.1 The specimen shall be the complete garment or article prepared as described in Method 7550.

3. NUMBER OF DETERMINATIONS

3.1 Unless otherwise specified in the procurement document, three specimens shall be tested from each sample unit.

4. APPARATUS, REAGENTS AND METHODS CITED

4.1 Apparatus.

4.1.1 Wash wheel. A wash wheel as described in Method 5550.

4.1.2 Preheating tank. A preheating tank or other device as described in Method 5556.

4.1.3 Extractor. An extractor as described in Method 5550.

4.1.4 Drier. A drier as described in Method 5556.

4.1.5 Hand-iron or conventional tailor's press equipped to maintain the temperature between 248° to 302°F (120° and 150°C).

4.1.6 Measuring scale. Measuring scale as described in Method 5550.

4.1.7 Water. A source of water as described in Method 5556.

4.2 Reagents.

4.2.1 The reagents shall be as described in Method 5556.

4.3 Methods cited.

Method 5550, Shrinkage in Laundering; Cotton, Linen, and Blended Cotton
and Linen Cloth

Method 5556, Mobile Laundry Evaluation for Textile Materials

Method 7550, Shrinkage in Laundering of Cotton and Linen Garments
and Ready-Made Articles

METHOD 7556

5. PROCEDURE

5.1 The procedure shall be as described in Method 5556, except for the following:

5.1.1 Pressing. A conventional tailor's press shall be used instead of the flat-bed press.

5.1.2 Dimensional measurement. The pressed specimen shall be measured as described in Method 7550.

5.1.3 Calculation of results. Shrinkage shall be calculated as follows:

Shrinkage, percent .
$$\frac{\text{Initial measurement} - \text{Measurement after laundering}}{\text{Initial measurement}} \times 100$$

6. REPORT

6.1 The shrinkage of the sample unit shall be the average of the specimens tested, and each dimension shall be reported separately to the nearest 0.1 percent.

6.2 The range in percent shrinkage between the highest and lowest values of the specimen shall also be reported.

METHOD 7558
July 20, 1978

SHRINKAGE RELAXATION;
WOOL GARMENTS AND READY-MADE ARTICLES

1. SCOPE

1.1 This method is intended for determining the relaxation of woven and knitted wool garments and articles.

2. TEST SPECIMEN

2.1 The specimen shall be the complete garment or article prepared as described in Method 7550.

3. NUMBER OF DETERMINATIONS

3.1 Unless otherwise specified in the procurement document, three specimens shall be tested from each sample unit.

4. APPARATUS AND METHODS CITED

4.1 Apparatus.

4.1.1 Sink. A sink or other container as described in Method 5590.

4.1.2 Drier. A drier described in Method 5556 except that it shall be provided with means for maintaining a stack temperature of $130^{\circ} + 2^{\circ}\text{F}$ ($54^{\circ} \pm 1^{\circ}\text{C}$) for 30 minutes.

4.1.3 Pressing equipment. Pressing equipment as described in Method 7556.

4.1.4 Measuring scale. Yardstick, meterstick, metal tape, or other suitable measuring device graduated in increments of 1/16 inch (1 mm).

4.1.5 Water. Source of water at a temperature of $80^{\circ} \pm 2^{\circ}\text{F}$ ($27^{\circ} \pm 1^{\circ}\text{C}$) and of not over 50 parts per million hardness.

4.2 Methods cited.

Method 5556, Mobile Laundry Evaluation for Textile Materials
Method 5558, Shrinkage, Relaxation; Wool Cloth
Method 7550, Shrinkage in Laundering of Cotton and Linen Garments and Ready-Made Articles

FED. TEST METHOD STD. No. 191A

METHOD 7558

Method 7556, Shrinkage in Laundering of Garments and Ready-Made Articles;
Mobile Laundry Method

5. PROCEDURE

5.1 The procedure shall be as described in Method 5558, except for the following:

5.1.1 Pressing. After drying, the specimen shall be pressed as described in Method 5556.

5.1.2 Dimensional measurement. The pressed specimen shall be measured as described in Method 7550.

5.1.3 Calculation of results. Shrinkage shall be calculated as follows:

Shrinkage, Percent = $\frac{\text{Initial measurement} - \text{Measurement after laundering}}{\text{Initial measurement}} \times 100$

6. REPORT

6.1 The shrinkage of the sample unit shall be the average of the specimens tested, and each dimension shall be reported separately to the nearest 0.1 percent.

6.2 Each individual value used to calculate the average shall also be reported.

METHOD 7560
July 20, 1978

SHRINKAGE IN LAUNDERING OF SHRINK-RESISTANT WOOL SOCKS

1. SCOPE

1.1 This method is intended for determining shrinkage during the relaxation process and the laundering of wool socks which have been given a shrink-resistant treatment. Shrinkage in laundering is the change in measured distances due to laundering.

2. TEST SPECIMEN

2.1 The specimen shall be one sock.

3. NUMBER OF DETERMINATIONS

3.1 Unless otherwise specified in the procurement document, eight specimens shall be tested from each sample unit.

4. APPARATUS, REAGENT AND METHOD CITED

4.1 Apparatus. (See figure 7560)

4.1.1 Sock measuring machine. The apparatus consists of a metal foot form over which the sock is drawn, so constructed that the toe section slides freely out of the heel section. This form shall be fixed in front of an upright arm bearing a scale graduated in divisions of 0.1 inch (1 mm) and shall have a freely rotating pulley at the top. A pivoting clamp shall be mounted at an angle so that it will hold the heel of the sock in a predetermined position. An indicator consisting of a pointer pin which is inserted through the toe of the sock and the hole in the toe piece of the form shall be provided. This indicator shall be attached by means of a cord which passes over a pulley on the upright to a weight formed of two sections, the smaller of which screws into a threaded opening in the base of the larger. When the short toe section is used, the small section of the weight shall be removed to compensate for the difference in weight of the toe sections. The pointed end of the pointer pin indicates the length of the sock under tension of 5 pounds (2.3 kg) by its position against the graduated scale on the instrument upright.

4.1.2 Wash wheel. A wash wheel as described in Method 5550.

4.1.3 Extractor. The extracting equipment shall be as described in Method 5550

4.1.4 Preheating tanks. A preheating tank or other device capable of supplying water in quantity and temperature as required in 5.2.

FED. TEST METHOD STD. NO. 191A

METHOD 7560

4.1.5 Water. A source of water which will furnish water containing not more than 50 parts per million of hardness.

4.2 Reagents.

4.2.1 Detergent. Soap meeting the requirements of type I, class 1 of P-S-1792, Soap, Laundry (Neutral and Built).

4.2.2 Sodium carbonate. Sodium carbonate meeting the requirements of types I or II of O-S-571, Sodium Carbonate, Anhydrous, Technical.

4.3 Method cited.

Method 5550, Shrinkage in Laundering; Cotton, Linen and Blended Cotton and Linen Cloth

5. PROCEDURE

5.1 Measurement of specimen. The specimen shall be placed over the metal foot form and the heel gore aligned with the pivoting clamp which has been brought to the position governed by the limit stop, and the clamp tightened. The toe gore shall be aligned with the center of the toe form and drawn smoothly through the sock and small hole in the top of the toe section, and the pull of the 5-pound (2.3 kg) weight shall be transferred to the sock in about 3 seconds. When socks are too short to go over the large toe form, the short toe form shall be used, in which case the lower separable portion of the weight shall be removed to compensate for the difference in weight of the form. The sock size under a load tension of 5 pounds (2.3 kg) for 1 minute shall be read directly from the scale and is the "foot-length" when evaluating the relaxation and foot shrinkage.

5.2 Determination of relaxation shrinkage. After the specimen has been measured according to 5.1, it shall be relaxed by soaking without agitation, in 20 to 30 times its weight of water containing 0.05 percent of neutral soap at a temperature of $81^{\circ} \pm 2^{\circ}\text{F}$ ($27^{\circ} \pm 1^{\circ}\text{C}$). The soaking process shall be continued for 2 hours at a temperature of $81^{\circ} \pm 2^{\circ}\text{F}$ ($27^{\circ} \pm 1^{\circ}\text{C}$). After this, the sock shall be extracted by means of the centrifuge for approximately 5 minutes, arranged evenly without wrinkles or tension on the drying tray, and allowed to dry at room temperature of 221° to 230°F (105° to 110°C). The sock shall then be brought to standard condition described in Section 4 of this Standard and measured as outlined in 5.1.

5.3 Determination of shrinkage after laundering. After determining the relaxation shrinkage, the socks shall be washed as follows:

Water at $140^{\circ} \pm 2^{\circ}\text{F}$ ($60^{\circ} \pm 1^{\circ}\text{C}$) shall be added to the machine until it reaches a level of 2 inches (51 mm) above the bottom of the cylinder. To this water a calculated amount of sodium carbonate shall be added to obtain a 0.2 percent solution and a minimum amount of neutral soap added to produce a low-level

METHOD 7560

suds. This condition is considered to have been reached when the suds come halfway up the cylinder on rotating the cylinder (cage) away from the operator. The specimen or specimens shall be added to the wash wheel with sufficient shrink resistant and nonfelted wool or wool not previously laundered for more than 6 hours, to make up a dry load of 5 pounds (2.3 kg) and the machine set in motion. Socks which contain 80 percent or less of wool shall be laundered for a period of 2 hours. Socks with more than 80 percent wool shall be laundered for 1 hour. The temperature of the washing solution shall be maintained at $140^{\circ} \pm 2^{\circ}\text{F}$ ($60^{\circ} \pm 1^{\circ}\text{C}$). At the end of the washing period, the machine shall be drained and the socks subjected to two 5-minute rinses with water at a temperature of $120^{\circ} \pm 2^{\circ}\text{F}$ ($49^{\circ} \pm 1^{\circ}\text{C}$). The rinse water depth shall be 10 Inches (254 mm) as measured from the bottom of the cylinder. After the second rinse the socks shall be extracted for 5 minutes, arranged evenly without wrinkles or tension on the drying tray, and dried as described in 5.2. The socks shall then be brought to standard condition as described in Section 4 of this Standard, and measured as described in 5.1.

5.4 Calculation of results.

5.4.1 Shrinkage shall be calculated as follows:

Relaxation shrinkage, = $\frac{\text{Initial measurement} - \text{Measurement after relaxation}}{\text{Initial measurement}} \times 100$
percent

Felting shrinkage, = $\frac{\text{Measurement after relaxation} - \text{Measurement after laundering}}{\text{Measurement after relaxation}} \times 100$
percent

Total shrinkage, = $\frac{\text{Initial measurement} - \text{Measurement after laundering}}{\text{Initial measurement}} \times 100$
percent

6. REPORT

6.1 The relaxation, felting, and total shrinkage of the sample unit shall be the average of the results obtained from the specimens tested and shall be reported separately to the nearest 0.1 percent.

6.2 Each individual value used to calculate the average shall also be reported.

SOCK MEASURING DEVICE

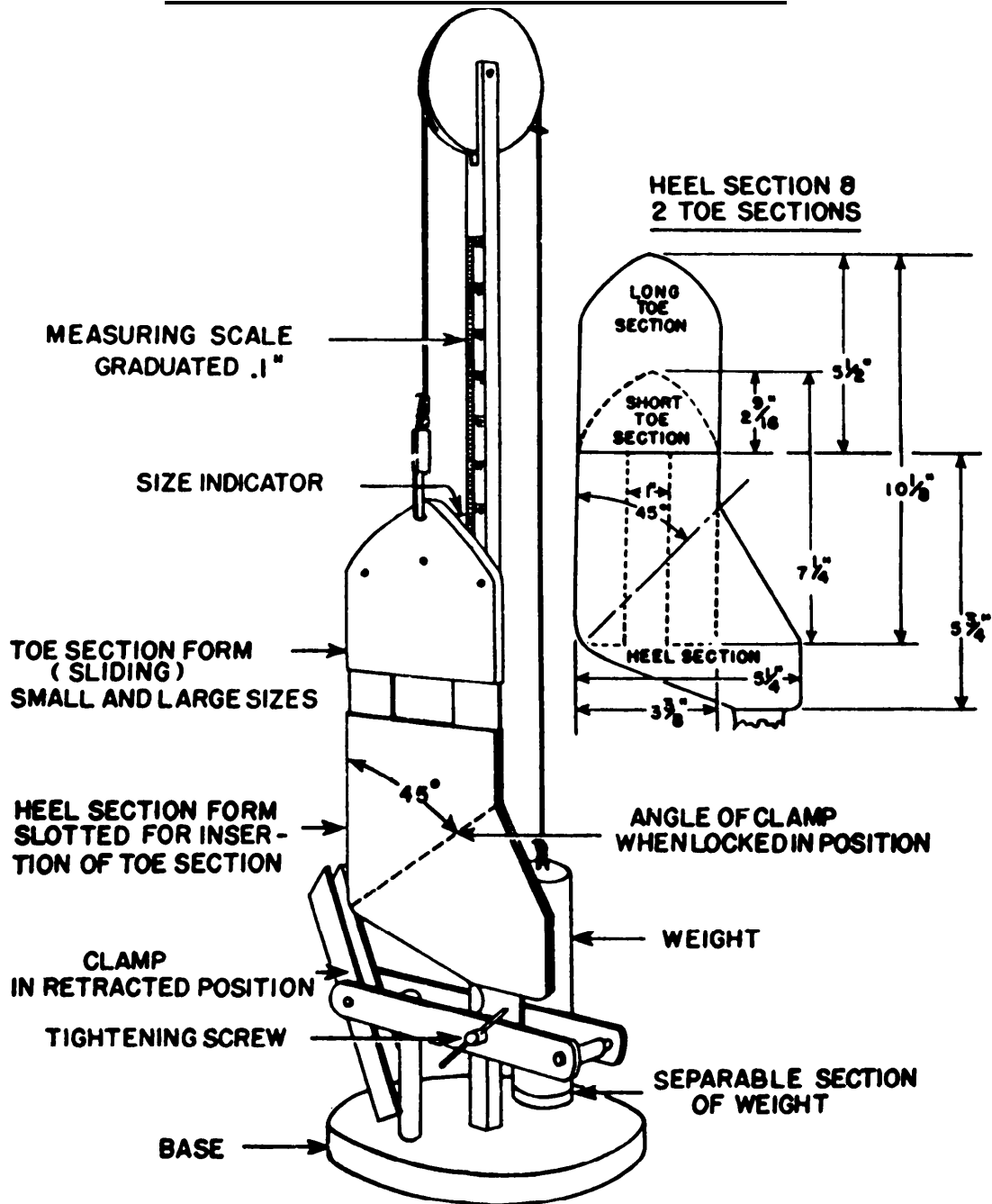

FIGURE 7560

METHOD 7561
July 20, 1978

SHRINKAGE IN LAUNDERING OF SHRINK-RESISTANT TREATED WOOL

SOCKS ; ACCELERATED METHOD

1. SCOPE

1.1 This method is intended for determining the relaxation and felting shrinkage of shrink-resistant treated socks by means of an accelerated procedure. This method is especially useful in determining, by one test, the shrinkage equivalent to a number of field mobile launderings. Shrinkage in laundering is the change in measured distances due to laundering.

2. TEST SPECIMEN

2.1 The specimen shall be one sock.

3. NUMBER OF DETERMINATIONS

3.1 Unless otherwise specified in the procurement document, eight specimens shall be tested from each sample unit.

4. APPARATUS, REAGENT AND METHODS CITED

4.1 Apparatus.

4.1.1 Sock measuring machine. A sock measuring machine as described in Method 7560.

4.1.2 Measuring scale. Yardstick, meterstick, metal tape, or other suitable measuring device graduated in increments of 0.1 inch (1 mm).

4.1.3 Wash wheel. Awash wheel as described in Method 5550.

4.1.4 Drying equipment.

4.1.4.1 Extractor. The extracting equipment shall be as described in Method 5550.

4.1.4.2 Drier. The drier shall be as described in Method 5556.

4.2 Reagent.

4.2.1 Buffering agent. Suitable agent for buffering the water to a pH of 7.0.

METHOD 7561

4.3 Methods cited.

Method 5550, Shrinkage in Laundering; Cotton, Linen and Blended Cotton and Linen Cloth

Method 5554, Shrinkage in Laundering; Wool Cloth; Accelerated

Method 5556, Mobile Laundry Evaluation for Textile Materials

Method 5558, Shrinkage, Relaxation; Wool Cloth

Method 7560, Shrinkage in Laundering of Shrink-Resistant Wool Socks

5. PROCEDURE

5.1 Measurement of specimen.

5.1.1 Foot length. The specimen shall be placed over a metal foot form and the heel gore aligned with the pivoting clamp which has been brought to the position governed by the limit stop and the clamp tightened. The toe gore shall be aligned with the center of the toe form and drawn smoothly back. The pin on the indicator shall be passed through the sock and small hole in the top of the toe form and the force of the weight applied slowly and uniformly (approximately 1 inch (25 mm) per second) to the sock. When socks are too short to go over the large toe form, the short toe form shall be used, in which case the lower separable portion of the weight shall be removed to compensate for the difference in weight of the form. The sock size under a load tension of 5 pounds (2.3 kg) for 1 minute shall be read directly from the scale and is the "foot length" when evaluating the relaxation and felting shrinkage.

5.1.2 Leg length. The sock shall be laid out without tension on a flat surface, care being taken that the sock is smooth and free from wrinkles or creases. The distance between the lower edge of the heel and the extreme top edge of the sock shall be marked with indelible ink or by other suitable means.

5.1.3 Leg width. With the sock in position for the leg measurement, the width of the leg shall be measured at a point equidistant from the lower edge of the heel and the extreme top edge of the sock to the nearest 0.1 inch (1 mm). The two points representing the ends of the measured leg width shall be marked with indelible ink or by other suitable means.

METHOD 7561

5.1.4 Foot width. With the sock in position for the leg length measurement, the width of the foot shall be measured at a point equidistant from the extreme tip of the toe to the back edge of the-heel to the nearest 0.1 inch (1 mm). The two points representing the ends of the measured foot width shall be marked with indelible ink or by other suitable means.

5.2 Relaxation shrinkage. The relaxation shrinkage shall be determined as described in Method 5558, 5.1 and 5.2.

5.2.1 After drying, the sock shall be brought to standard condition as described in Section 4 of this Standard and measured again as described in 5.10

5.3 Felting shrinkage. The felting shrinkage of the socks which have been previously relaxed shall be determined as described in Method 5554, 5.1 and 5.2.

5.3.1 After drying the socks shall be brought to standard condition and measured again as described in 5.1.

5.4 Calculation of results.

5.4.1 Shrinkage shall be calculated as follows:

Relaxation shrinkage, percent =

$$\frac{\text{Initial measurement} - \text{Measurement after relaxation}}{\text{Initial measurement}} \times 100$$

Felting, shrinkage, percent =

$$\frac{\text{Measurement after relaxation} - \text{Measurement after laundering}}{\text{Measurement after relaxation}} \times 100$$

6. REPORT

6.1 The relaxation and felting shrinkage of the sample unit shall be the average of the results obtained from the specimens tested and shall be reported to the nearest 1.0 percent.

6.2 Each individual value used to calculate the average shall also be reported.

METHOD 7580
July 20, 1978

SHRINKAGE IN DRY CLEANING; GARMENTS AND READY-MADE

ARTICLES

1. SCOPE

1.1 This method is intended for determining the shrinkage of woven garments and ready-made articles when dry cleaned. It may be used for some knitted articles. Shrinkage in dry cleaning is the change in measured distance due to dry cleaning.

2. TEST SPECIMEN

2.1 The specimen shall be the complete garment or article prepared as described in Method 7550.

3. NUMBER OF DETERMINATIONS

3.1 Unless otherwise specified in the procurement document, three specimens shall be tested from each sample unit.

4. APPARATUS, REAGENTS AND METHODS CITED

4.1 Apparatus.

4.1.1 Tumble jar, steam board and pressing equipment. The tumble jar, steam board or table, and pressing equipment shall be as described in Method 5580.

4.1.2 Drying equipment. The drying equipment shall be as described in Method 5550.

4.1.3 Measuring scale. Yardstick, meterstick, metal tape, or other suitable measuring device graduated in increments of 1/16 inch (1 mm).

4.2 Reagents.

4.2.1 The reagents shall be as described in Method 5580.

FED. TEST METHOD STD. NO. 191A

METHOD 7580

4.3 Methods cited.

Method 5550, Shrinkage in Laundering; Cotton, Linen and Blended Cotton and Linen Cloth

Method 5580, Shrinkage in Dry Cleaning; Cloth

Method 7550, Shrinkage in Laundering of Cotton and Linen Garments and Ready-Made Articles

50 PROCEDURE

5.1 The procedure shall be as described in Method 5580, except for the following:

5.1.1 Pressing. After drying, the specimen shall be pressed as described in Method 5550.

5.1.2 Evaluation. The pressed specimen shall be measured as described in Method 5550.

5.1.3 Calculation of results. Shrinkage shall be calculated as follows:

Shrinkage, percent = $\frac{\text{initial measurement} - \text{Measurement after laundering}}{\text{Initial measurement}} \times 100$

6. REPORT

6.1 The shrinkage of the sample unit shall be the average of the specimens tested, and each dimension shall be reported separately to the nearest 0.1 percent.

6.2 Each individual value used to calculate the average shall also be reported.

METHOD 7590
July 20, 1978

SHRINKAGE IN SPONGING; GARMENTS AND READY-MADE ARTICLES

1. SCOPE

1.1 This method is intended for determining the shrinkage in sponging of wool and wool mixture garments and ready-made articles. It is less severe than laundering methods. Shrinkage in sponging is the change in measured distances due to sponging.

2. TEST SPECIMEN

2.1 The specimen shall be the complete garment or article prepared as described in Method 7550.

3. NUMBER OF DETERMINATIONS

3.1 Unless otherwise specified in the procurement document, three specimens shall be tested from each sample unit.

4. APPARATUS, REAGENT AND METHODS CITED

4.1 Apparatus

4.1.1 Sink or washwheel. A sink, washwheel, or similar apparatus of such shape and size as to allow the specimen to be laid flat and soaked without folding.

4.1.2 Measuring scale. Yardstick, meterstick, metal tape, or other suitable measuring device graduated in increments of 1/16 inch (1 mm).

4.1.3 Drying equipment.

4.1.301 Rack and drying trays. A rack and tray of any convenient size over 22 by 22 inches (559 mm by 559 mm). The bottoms of the trays shall be a wire mesh, and the size of the mesh shall be a minimum of 1/2 by 1/2 inch (13 mm by 13 mm). When the trays are in the rack, they shall be separated by a distance of not less than 1-1/2 inches (38 mm) and openings shall be provided in the rack for circulation of the air.

METHOD 7590

4.1.3.2 Extractor. A centrifugal extractor of the laundry-type with a perforated basket, approximately 11 inches (279 mm) deep by 17 inches (432 mm) in diameter, with an operating speed of approximately 1500 revolutions per minute.

4.1.3.3 Drying oven. A circulating-air oven thermostatically controlled and capable of maintaining the temperature at 221° to 230°F (105° to 110°C).

4.1.4 Pressing equipment. A flat-bed press measuring 24 inches by 50 inches (610 mm x 1270 mm) or larger. Any flat-bed press capable of pressing a specimen 22 inches (559 mm) square or a hand-iron weighing approximately 6 pounds (2.7 kg) may be used as an alternative. The flat-bed press or iron shall be equipped with a temperature control to maintain the temperature between 275° and 300°F (135° and 149°C).

4.2 Reagent.

4.2.1 Wetting agent. A wetting agent such as the dioctyl ester of sodium sulfosuccinic acid (Deceresol OT, Aerosol OT) or equivalent.

4.3 Methods cited.

Method 5550, Shrinkage in Laundering; Cotton, Linen and Blended Cotton and Linen Cloth

Method 7550, Shrinkage in Laundering of Cotton and Linen Garments and Ready-Made Articles

5. PROCEDURE

5.1 Wetting-out. Water containing 0.03 percent by volume of active ingredient of the wetting agent shall be added to the container in sufficient quantity to completely cover the specimen. A solution composed of 22 gallons (83.3 L) of water plus 100 ml of 25 percent concentrated "Deceresol OT" has been found suitable for wetting-out 6 pounds (2.7 kg) of material. The water shall be at a temperature of 75° to 85°F (24° to 29°C) and shall have not over 50 parts per million hardness. The specimen shall be placed in the water and kept submerged without agitation for a period of 60 ± 1 minute. Each specimen shall be separately laid flat in the water without folding. Care shall be taken to see that each specimen is wet-out.

5.2 Drying. The specimen shall be dried as described in Method 5550.

METHOD 7590

5.3 Evaluation. The pressed specimen shall be measured as described in Method 5550.

5.4 Calculation of results.

Shrinkage, percent=
$$\frac{\text{Initial measurement} - \text{Measurement after laundering}}{\text{Initial measurement}} \times 100$$

6. REPORT

6.1 The shrinkage of the sample unit shall be the average of the specimens tested, and each dimension shall be reported separately to the nearest 0.1 percent.

6.2 Each individual value used to calculate the average shall also be reported.

7. NOTES

7.1 Machines of the type described in this method may be purchased from Ewing Division of Powercom, P.O. Box 454, Troy, NY 12181.

METHOD 9010
July 20, 1978

SHADE MATCHING OF TEXTILE MATERIALS;

VISUAL METHOD

1. SCOPE

1.1 This method is intended for determining shade of textile materials by visual comparison against standard shade references and, when available, a range of tolerance.

2. TEST SPECIMEN

2.1 Dyed woven or knitted cloths. The test specimen shall be a representative rectangle of cloth, 5 inches (127 mm) in the warp by 8 inches (203 mm) in the filling direction taken from the bolt, roll, or piece of cloth. All surfaces shall be clean and free from stains or soiling of any type. Torn edges, markings or other marks shall be removed from the matching area. For woolen cloths, the shear jump area shall not be included.

2.2 Narrow cloths, braids, tapes, webbings. The test specimen shall be a minimum of 8 inches (203 mm) in length and the full width as received. It may be or may not be cut from the sample unit.

2.3 Loose fiber. The test specimen shall be carded and made into a suitable size lap or pad for visual comparison.

2.4 Threads, yarns. The test specimen shall be in skein form, wound on a card to form a compact area of parallel yarns or knitted to suitable size.

3. NUMBER OF DETERMINATIONS

3.1 Woven or knitted cloths, narrow cloths, braids, tapes, and webbings. Unless otherwise specified in the procurement document, one specimen per bolt, roll, or piece of cloth shall be tested. Each bolt, roll, or piece in a lot shall be tested for shade.

3.2 Threads, yarns, and loose fiber. Unless otherwise specified in the procurement document, three specimens shall be tested from each sample unit.

4. APPARATUS

4.1 Shade board. The shade board shall be of a material, preferably wood, providing a planed surface with no distortions or depressions. The board shall form a platform set at an angle of 37 ± 2 degrees to the horizontal

METHOD 9010

above a table or cabinet placed within an area painted to Munsell Neutral Color N 8/(see 7.7) having a flat reflectance curve characteristic across the visible spectrum (see 7.1) so that no spectral distortion of the light possibly reflected to the shade board can occur. The shade board shall be shielded from extraneous light. There shall be no apparent reflections on the shade board from surrounding surfaces.

4.2 Color matching lamp light source (see 7.2). The color matching lamp shall be an assembly of individual lamps to match the curve for Abbot-Gibson daylight at a correlated color temperature of $7500\text{ K} \pm 200\text{ K}$ (simulated north sky daylight generally referred to as CIE Source D 75) (see 7.8.11) and a minimum level of 100 foot-candles. The drop in illumination intensity from the center of the board to the periphery shall be not more than 25 foot-candles. The shade board and color matching lamp shall be exactly parallel to each other and shall be so aligned that the light flux centers at the center of the shade board. An offset, only to the degree necessary to eliminate shadow of the observer, shall be permitted.

4.2.1 An array of 300-watt incandescent photoflood lamps wired with internal resistance in the circuit to provide a color temperature between 2200 K (horizon sunlight) and 2854 K (CIE Source A) (see 7.8.11).

4.2.2 An arrangement of six evenly spaced 15-watt backlight ultra violet (UV) tubes to provide UV content to the daylight source or to be used as such in checking fluorescence.

4.2.3 The light flux shall be transmitted to the shade board through water white optical non-color selective diffusing glass with high diffusion efficiency. For maximum diffusing efficiency, the diffusing glass shall have a waffle pattern on one side and fluted edges on the other.

4.2.4 A blower of suitable size shall be attached to the lamp for cooling. Means shall be provided for eliminating the hot air exhaust from the lamps. The air in the test area shall be clean, filtered if necessary.

4.2.5 The electric light bulbs, Corning filters (see 7.5), and diffusing glass of the lamp shall be cleaned periodically using a mild soap and water solution, a 50/50 alcohol-water mixture or other suitable solution which will not adversely affect the transmission and spectral quality of the glass.

4.2.6 A color temperature meter (see 7.3).

4.2.7 A foot-candle meter (see 7.4).

4.3 Standard (Cool White) fluorescent light.

4.4 Blotting paper

FED. TEST METHOD STD. NO. 191A

METHOD 9010

5. PROCEDURE

5.1 In case of dispute and when obvious finish differences between the standard reference and specimen exist. Preparation of specimens containing wool fiber and those displaying a high degree of finish: The standard shade, tolerances and test specimen shall be wetted by immersion in the water containing a small amount of alkylaryl polyether alcohol. No mechanical action shall be used. The specimen shall be removed from the water, blotted free of excess moisture between sheets of blotting paper and dried without mechanical action on the specimen at a temperature not to exceed 160°F (71°C).

5.2 The shade board shall be covered with the shade standard. When the shade standard is of insufficient size to cover the board, a neutral gray with a flat spectral response of approximately the same lightness level as the shade standard or the shade to be evaluated shall be used to cover the board. The tolerance or shade range specimens shall be placed across the upper edge of the standard. The tolerance or shade range shall include a sample of the standard. The test specimen shall be placed on the shade board overlapping the standard sample and in the same plane and with the weave design in the same direction. Unless otherwise specified, all samples shall be placed on the shade board with the warp direction running up and down the short dimension of the shade board. The observer, whose vision has been tested and found to be normal by using the ISCC-A0 Pseudoisochromatic Plates (see 7.6) and the Farnsworth Munsell 100 Hue Test (see 7.7) or equally accepted method, shall stand before the shade board with his eyes at a level which permits the observer to look into the samples to be matched at an angle of 90 degrees and insure a minimum blocking of the light upon the standard. The viewing distance shall be 30 inches \pm 6 inches (762 mm \pm 152 mm) while performing the test, and the observer shall not move his head or change the angle of view. Decisions as to whether the test specimen falls within or without the tolerance limits shall be made as rapidly as possible, as prolonged viewing tends to cause blending effects.

5.3 The test specimen shall be compared to the standard under the 7500 K \pm 200 K daylight source (see 4.2). An evaluation as to its lightness and chromaticity or hue characteristics relative to the standard shall be made. The test specimen shall also be compared to the tolerances. An evaluation as to which tolerance it comes closest to or whether it departs further from the standard than the tolerances in lightness and chromaticity, shall be made.

5.4 The test specimen shall then be compared to the standard under the 2200 K to 2854 K source (see 4.2.1). An evaluation as to its lightness and chromaticity characteristics relative to the standard shall be made.

5.4.1 When bleached whites, fluorescent materials or materials containing fibers suspected of being optically brightened are being tested, they shall be evaluated under a 7500 K \pm 200 K source (see 4.2). When specified,

METHOD 9010

an ultra violet source shall be added to the 7500 K + 200 K source. An evaluation as to its lightness and chromaticity characteristics—relative to the standard shall be made under the combined source. The test specimen shall then be compared to the tolerances. An evaluation as to which tolerance it comes closest to or whether it departs further from the standard than the tolerance in lightness and chromaticity, shall be made.

5.4.2 When specified, a further evaluation shall be made under a standard cool white fluorescent light.

5.5 When specified, specimens may be checked for total fluorescence and chromaticity against the standard of reference using the ultra violet source only.

5.6 In cases of dispute only, to eliminate any questions as to possible slight aberrations in color vision that might occur due to human factors, at least two observers shall perform the evaluation and agree.

5.7 Unless otherwise specified, deviations from the standard procedure, i.e., tilting of the specimens, changing of the angle of view of the observer may not be performed in evaluating the specimen.

6. REPORT

6.1 Tolerance range available. Unless otherwise specified in the procurement document, when a tolerance range is available, shade matching of each individual specimen tested shall be reported as "pass" or "fail" for lightness and chromaticity in respect to the standard and related established tolerances. A passing result which is approaching borderline conditions, i.e., failure, shall be reported to serve as a guide for future production.

6.1.1 In the event of failure, the report shall state the specific nature of the failure and the applicable direction of failure to enable production personnel to bring the shade within the acceptable limits. —

6.2 No tolerance range available. Unless otherwise specified in the procurement document, when a tolerance range is not available, shade matching shall be reported as "pass" or "fail" as compared to the standard sample for lightness and chromaticity.

6.3 Fluorescent materials. When fluorescent materials are tested, the test report shall indicate use of the ultra violet source or additional fluorescent lights .

7. NOTES

7.1 The nominal calorimetric specifications for a suitable neutral gray are as follows:

FED. TEST METHOD STD. NO. 191A

METHOD 9010

x = 0.314
 y = 0.331
 z = 59.1%
 Source D65 reference MgO

7.2 A suitable lamp meeting these requirements contains 10 (1000-2000 watt) tungsten filament lamps with daylight filters; 14 (300 watt) photoflood lamps and six (15 watt) backlight *W* tubes may be obtained from the Macbeth Daylight Corporation, Newburgh, NY 12550, and is called the Macbeth Super Skylight BX 1014.

7.3 A suitable color temperature meter may be obtained from the Photo Research Corporation, 837 North Cahuenga Blvd., Hollywood, CA.

7.4 A foot-candle meter may be obtained from the Weston Electrical Instrument Corporation, Newark, NY 07102, and is called the Model 614 Weston Foot-Candle Meter.

7.5 Corning filters vary in thickness and the color temperature achieved is dependent to a degree on this factor. The relationship between the color temperature of the illuminant and the effective color temperature of the filtered radiation that follows, is to a close approximation:

$$\frac{1}{T_1} - \frac{0.1}{T_2} = Kt$$

where: T₁ = color temperature of the illuminant
 T₂ = effective color temperature of the filtered radiation
 t = thickness of the glass filter
 K = constant characteristic of the melt

The light source for the level of color matching required under this method shall be required to have a conformity index of ± 127.3. The conformity index is calculated as shown in the following table:

METHOD 9010

Computation of Conform= Index for Source HavingContinuous Spectrum Only

Band No.	Wave length (μ) mu	Test source rel. energy	Adjusted to equal std. Col 3 x k* rel. energy	Standard source rel. <u>energy</u>	Standard test rel. <u>energy</u>	Source
1	400	81.8	92.5	104.7	12.2	
2	410	100.3	113.5	125.5	12.0	
3	420	109.6	124.0	128.4	4.4	
4	430	116.4	131.7	124.2		7.5
5	440	118.1	133.6	128.0		5.6
6	450	119.5	135.2	132.6		2.6
7	460	117.0	132.4	132.1		0.3
8	470	113.9	128.8	130.8	2.0	
9	480	109.7	124.1	128.1	4.0	
10	490	106.5	120.5	124.0	3.5	
11	500	101.6	118.3	120.2	1.9	
12	510	101.6	114.1	115.9	1.0	
13	520	96.9	109.6	111.4	1.8	
14	530	90.7	102.6	107.2	4.6	
15	540	88.0	99.6	104.1	4.5	
16	550	91.8	103.8	102.0		1.8
17	560	100.0	113.0	100.0		13.1
18	570	104.8	118.6	98.1		20.5
19	580	99.5	112.6	96.7		15.9
20	590	85.4	96.6	95.5		1.1
21	600	76.8	86.9	93.9	7.0	
22	610	76.2	86.2	91.1	4.9	
23	620	73.0	82.6	88.4	5.8	
24	630	68.2	77.1	85.9	8.8	
25	640	59.7	67.5	83.8	16.3	
26	650	56.7	64.1	81.6	17.5	
27	660	58.7	66.4	79.8	13.4	
28	670	67.5	76.4	78.1	1.7	
29	680	76.8	86.9	76.6		10.3
30	690	85.1	96.3	74.5		21.8
31	700	87.4	98.9	72.1		26.8
Totals:		2842.2	3215.3	3215.3	127.3	127.3**

FED. TEST METHOD STD. NO. 191A

METHOD 9010

Total of column 5 = 3215.3
- 1.1313

* Constant K = (Total of Column 3) - 2842.2

** Conformity = \pm 127.3

7.6 ISCC-A0 Pseudoisochromatic Plates may be obtained from the American Optical Co., Instrument Division, Southbridge, MA 01550.

7.7 A sample of Munsell Neutral Color N8/, or the Farnsworth-Munsell 100 Hue Test may be obtained from the Munsell Color Company, Inc., 2441 No. Calvert Street, Baltimore, MD 21218.

7.8 Three forms of language are generally used in the textile industry; the standard psychophysical terminology, psychological terminology, and the idiom confined to use by the practical dyer. All three forms are utilized to define shade and color properties as follows:

7.8.1 Dominant wave length or hue. Terms that psychophysically and psychologically, respectively, denote the attribute of color by which an object is judged to be red, blue, yellow, etc. The idiom of the trade is hue.

7.8.2 Lightness. That attribute of color which defines amount of light reflected from a material or the attribute of color perception by means of which a surface is judged to reflect more or less light than another surface, i.e., depth of shade; darker or lighter in the idiom of the trade.

7.8.3 Purity or chroma. The proportion of spectrally pure color in the shade or perceptually the attribute that expresses the degree of departure from the gray of the same lightness, i.e., brighter or duller in the idiom of the trade. The term "flat" may also be used to indicate an extreme low order of saturation or purity. A comparable term often used is "chroma".

7.8.4 Metamerism. The attribute of two colored bodies, matching well under one light source, to change their shade differently when exposed to light of different spectral distribution, in the idiom of the trade, the shade change that occurs in going from daylight to artificial light, usually defined as unfiltered tungsten light. When a single sample is viewed under two separate light sources of different spectral distribution, the change in shade is usually defined in the trade as the "flare".

7.8.5 Photochromism. That attribute of a colored body to progressively change shade with time of exposure to a given illuminating source. This attribute is usually reversible upon placing the specimen in the dark.

METHOD 9010

7.8.6 Specular or glossy. A surface that reflects strongly in a direction opposite the incident beam, is highly reflective and acts somewhat as a mirror. Usually derived from severe finishing and processes such as decating, calendering and schreinerling.

7.8.7 Standard sample. A material that defines the specific shade to be color matched in production. It may also define other properties as specified, i.e., colorfastness or degree of finish.

7.8.8 Tolerance range. A scientifically spaced group of shades closely allied to the standard sample but deviating from it in steps of chromaticity or lightness or both, and which define the outer limits of acceptability for conformance to the required shade.

7.8.9 Shade range. A visually selected group of shades closely allied to the standard sample but not scientifically spaced as in the case of the tolerance range.

7.8.10 Shading. That attribute of a cloth surface wherein the color varies across the width of cloth or from one end of a roll or bolt to the other. Side to side and end to end shadings are usually indications of defects in processing or equipment maintenance.

7.8.11 CIE. Stands for Commission International d'Eclairage, or International Commission on Illumination.

SECTION 10 - SUPERSESSION DATA, SOURCE INFORMATION, AND
INTERESTED AGENCIES

10.1 Supersession data. This Standard incorporates and supersedes all the provisions of FED. TEST METHOD STD. NO. 191, Textile Test Methods dated 31 December 1968, and Change Notices 1 through 5 thereto. In addition, testing procedures were revised as required, and the sectional format in all methods was standardized to provide for a more technically adequate and updated laboratory tool.

10.1.1 New methods. The following new methods have been included, and will take effect on date of issue of this standard.

Method 2016 - Sodium Salt of [(4, 5-Dichloro, 2-Chloromethane Sulfonyl) 3', 4', 6' Trichloro] Diphenyl Ether Content

Method 2535 - Polyester Content of Fiber Mixtures

Method 2820 - Chitin Content of Textiles, as a Measure of Fungal Contamination

Method 5052 - Stitches per Unit Length in Seams and Stitchings; Determination of

Method 5216 - Durable Press on Fabrics, Shirts and Trousers; Evaluation of; Cloth Appearance, Seam Appearance, Fly Appearance, Crease Appearance and Soil Release

10.2 Source information and interested agencies.

(Activities outside the Federal Government may obtain copies of Federal Specifications, Standards, and Handbooks as outlined under General Information in the Index of Federal Specifications and Standards and at the prices indicated in the Index. The Index, which includes cumulative monthly supplements as issued, is for sale on a subscription basis by the Superintendent of Documents, us Government Printing Office, Washington, DC 20402

(Single copies of this specification and other Federal Specifications required by activities outside the Federal Government for bidding purposes are available without charge from Business service Centers at the General Services Administration Regional Offices in Boston, New York, Philadelphia, Washington, DC, Atlanta, Chicago, Kansas City, MO, Fort Worth, Houston, Denver, San Francisco, Los Angeles, and Seattle, WA.

(Activities outside activities may obtain copies of Federal Specifications, Standards, and Handbooks and the Index of Federal specifications and standards from establish distribution points in their agencies)

MILITARY CUSTODIANS

Army - GL
Navy - SA
Air Force - 11

Review activities:

Army - AR, EL, MD, ME, MI, TE
Navy - AS, SH
Air Force - 03, 45, 99
DLA - "CT

User activity:

Navy - MC

Preparing activity:

Army-GL

Civil Agency Coordinating Activities:

GSA - FSS
VA - MS
HEW - NIH

Project No. 83GP-0342

FED. TEST METHOD STD. NO. 191A