

DOCUMENT RESUME

ED 233 229

CE 036 786

AUTHOR Courson, Roger L.; And Others  
 TITLE Core III Materials for Rural Agriculture Programs. Units H-I.  
 INSTITUTION Illinois Univ., Urbana. Dept. of Vocational and Technical Education.  
 SPONS AGENCY Illinois State Board of Education, Springfield. Dept. of Adult, Vocational and Technical Education.  
 PUB DATE Jun 83  
 CONTRACT R-33-13-D-0362-466  
 NOTE 499p.; Not available in paper copy due to colored paper. For related documents, see ED 208 148-153, ED 220 689-690, ED 222 663-664, and CE 036 785-788.  
 PUB TYPE Guides - Classroom Use - Guides (For Teachers) (052)  
 EDRS PRICE MF02 Plus Postage. PC Not Available from EDRS.  
 DESCRIPTORS \*Agribusiness; \*Agricultural Education; \*Agricultural Engineering; Agricultural Machinery; Agricultural Occupations; Career Education; \*Classroom Techniques; Construction (Process); Electricity; Engines; Farm Management; High Schools; Instructional Materials; Learning Activities; Learning Modules; Livestock; Marketing; Masonry; Mechanics (Process); Occupational Information; State Curriculum Guides; \*Teaching Methods; Units of Study; \*Vocational Education  
 IDENTIFIERS Illinois

ABSTRACT

This curriculum guide includes teaching packets for nine problem areas of study to be included in a core curriculum for 11th-grade or third-year students enrolled in rural agricultural programs in Illinois. Each problem area includes some or all of the following components: suggestions to the teacher, a teacher guide, a competency inventory, an information sheet, student worksheets or assignment sheets with key, demonstrations, job sheets, transparencies, a discussion guide for transparencies, and sample test questions and teacher key. The nine problem areas in this guide are grouped into two units. The first unit, on agricultural mechanics, covers these six problem areas: (1) constructing and maintaining buildings, (2) developing electrical wiring skills, (3) adjusting and maintaining planting equipment, (4) maintaining and repairing small engines, (5) adjusting and maintaining combine harvesting equipment, and (6) developing concrete masonry skills. The second unit, on agricultural business management, covers (1) four ways of doing business in agriculture, (2) marketing agricultural crops, and (3) marketing livestock and livestock products. (KC)

\*\*\*\*\*  
 \* Reproductions supplied by EDRS are the best that can be made \*  
 \* from the original document. \*  
 \*\*\*\*\*

168313306

CORE III MATERIALS  
FOR RURAL  
AGRICULTURE  
PROGRAMS  
UNITS H-I  
Project Staff

Sponsored by  
ILLINOIS  
STATE BOARD OF  
EDUCATION

DEPARTMENT OF  
ADULT,  
VOCATIONAL AND  
TECHNICAL EDUCATION

Edward Copeland  
Chairman

Research and  
Development Section

Co-directors:  
Paul Hemp  
Roger L. Courson

Donald G. Gill  
State Superintendent  
of Education

June, 1983

Developers:  
Roger Courson  
Paul Hemp  
Jerry Pepple  
Al Zwilling

Department of  
Vocational and  
Technical Education  
and Vocational  
Agriculture Service,  
University of Illinois  
at Urbana-Champaign

ED233229

CE, 036 786

U.S. DEPARTMENT OF EDUCATION  
NATIONAL INSTITUTE OF EDUCATION  
EDUCATIONAL RESOURCES INFORMATION  
CENTER (ERIC)

This document has been reproduced as  
received from the person or organization  
originating it.  
Minor changes have been made to improve  
reproduction quality.

Points of view or opinions stated in this docu-  
ment do not necessarily represent official NIE  
position or policy.

"PERMISSION TO REPRODUCE THIS  
MATERIAL HAS BEEN GRANTED BY

*Cher...*

TO THE EDUCATIONAL RESOURCES  
INFORMATION CENTER (ERIC)."

## UNIT H: AGRICULTURAL MECHANICS

### PROBLEM AREA: CONSTRUCTING AND MAINTAINING BUILDINGS

#### SUGGESTIONS TO THE TEACHER:

This problem area is designed for use with eleventh grade or advanced students in vocational agriculture programs. The recommended time for teaching this problem area is during the winter months when the laboratory would be available for demonstrations and projects.

The estimated instructional time for this problem area is 1 to 6 weeks depending on how far the teacher wishes to go in developing knowledge and skills in constructing buildings and structures. If the student are to be involved in other activity exercises, the instructional time will need to be increased.

The instructor is encouraged to conduct a local search to locate other supplementary materials for use with this problem area. The items in this problem area are for reference or modification as instructors adapt these materials to their local situation.

#### CREDIT SOURCES:

These materials were developed through a funding agreement, R-33-13-D-0362-466, with the Illinois State Board of Education, Department of Adult, Vocational and Technical Education, Research and Development Section, 100 North First Street, Springfield, Illinois 62777. Opinions expressed in these materials do not reflect, nor should they be construed as policy or opinion of the State Board of Education or its staff.

The teacher's guide, student worksheets, and project plans were developed by Jerry Papple, Department of Vocational and Technical Education, University of Illinois, and Carl Burkybile, Vocational Agriculture Instructor, Rantoul High School, Rantoul, Illinois. The plans for the utility shed were adapted from materials provided by Dan Brewer, Building Trades Instructor, Findlay, Illinois. Transparency masters and the transparency discussion guide were prepared by the Vocational Agriculture Service, University of Illinois. Suggestions and guidance in the development of these materials were provided by the Rural Core Curriculum Field Test Teachers. This problem area was reviewed by the following vocational agriculture teachers:

Carl Burkybile	-	Rantoul High School
Phil Brown	-	Harvard High School
Richard Dunn	-	Seneca High School
Donald Miller	-	New Holland-Middletown High School

## TEACHER'S GUIDE

- I. Unit: Agricultural mechanics
- II. Problem area: Constructing and maintaining buildings
- III. Objectives: At the close of this problem area students will be able to:
  1. Understand how lumber is graded for quality.
  2. Recommend the most economical lumber for agricultural structures when considering the purpose of the job and quality grade requirements.
  3. Explain advantages of plywood in agricultural construction.
  4. Read and interpret a plywood grade-trademark.
  5. Properly use the carpenter's square in agricultural construction.
  6. Identify advantages of metal roofing and siding for agricultural structures.
  7. Identify advantages of asphalt roofing for agricultural structures.
  8. Read and follow project plans and blueprints.
- IV. Suggested interest approaches:
  1. Display an assortment of milled lumber and plywood pieces and have students identify the kinds, grades, and uses of each example.
  2. Prepare a bulletin board display indicating timely information about the use of lumber and/or careers in the industry.
  3. Discuss the issues involved in selecting lumber for a specific job.
  4. Identify and show a film pertaining to uses of lumber in construction.
  5. Obtain samples of roofing materials and discuss where and when each could be used.
  6. Show transparency on types of rafters and ask students if they can identify each part and the types of lumber used.



7. Display a cross section of a tree trunk and have students label the various parts.
8. Ask students to identify the different types of squares found in the agriculture shop and when they have used each.
9. Ask students to relate experiences they have had in building or repairing agricultural structures.
10. Discuss importance of carpentry skills in popular employment areas of agriculture.

V. Anticipated problems and concerns:

1. What is wood and how does it develop?
2. How is lumber milled and seasoned?
3. What are some uses of wood in agriculture?
4. How is lumber graded?
5. Who grades lumber and why?
6. How can I select the best type of lumber for a job?
7. How is lumber sized and sold?
8. What care should be given to lumber to maintain its quality and usefulness?
9. What are some advantages of using plywood in agricultural construction?
10. What kinds of plywood are available?
11. When can plywood be used in agricultural construction?
12. What are some approved practices to observe when using plywood?
13. How do I use the carpenter's square when building a project?
14. What factors should I consider when selecting roofing and siding materials?
15. How do I apply roofing and siding materials to buildings?
16. How do I repair and paint metal roofing and siding materials?

VI. Suggested learning activities and experiences:

1. Review the Rural Core I problem areas, "Developing Safe Work Habits in Agricultural Mechanics" and "Developing Basic Carpentry Skills" with the students. Discuss and have students demonstrate the basic skills covered in these problem areas. Review important approved practices in laboratory safety.
2. Select and conduct an interest approach on agricultural carpentry.
3. Develop class goals and objectives for constructing and maintaining agricultural structures and buildings.
4. Have class identify problems and concerns which they need to solve to accomplish their goals and objectives.
5. Select problems and concerns relating to lumber and its use. Use VAS Unit 3055 and the worksheet, "Using Lumber in Construction" to help identify and solve selected problems and concerns.
6. Have class identify native trees which are used for lumber and have class calculate cost of various species (i.e., pine, walnut, oak, etc.) per board feet.
7. Ask class to identify where the various types of lumber are used in home construction or in barns and sheds.
8. Develop a list of problems and concerns relating to plywood. Use VAS Unit 3042 and selected transparencies on Plywood Construction as reference. Use worksheet on "Using Plywood in Construction" as supplement to identify other questions relating to the use of plywood.
9. Review the use of the carpenter's square by using worksheets, "Proper Use of Carpenter's Square," and VAS Unit 3009a as a reference.
10. Select one or more projects relating to this problem area and have students construct the project for assignment.
11. Use selected transparencies and worksheet "Parts of a Building" as a means of helping students identify the parts of a building and how to apply roofing and siding materials.
12. Plan and conduct a class field trip to a building under construction and have students identify various parts. Use carpenter or contractor as resource person to explain basic construction techniques and practices.

13. Select a large class project, such as a storage shed and have class build the project.
14. During the planning and construction phase, evaluate the class progress and quality of work done.
15. After project is completed, have the class evaluate the project in terms of the criteria listed in VAS Unit 3051.
16. Distribute the Competency Sheet included in this problem area and let students evaluate their level of skill development. Have them identify possible ways they can improve their weaker skills.

VII. Application procedures:

1. Encourage students to construct or repair buildings or structures around their home as part of their S.O.E.P.
2. This problem area should increase student awareness of the importance of proper planning and construction procedures when working at home or on-the-job.

VIII. Evaluation:

1. Prepare and administer a pencil and paper test covering the following: selecting, buying, and using lumber; selecting and using siding and roofing materials; use of the carpenter's square.
2. Evaluate worksheet assignments.
3. Prepare and administer laboratory practical exam on proper use of basic carpenter's tools and on identification of parts of a building.
4. Assign students a carpentry remodeling or building project and evaluate their work habits and skill development.

IX. References and aids:

Vocational Agriculture Service, College of Agriculture, University of Illinois, 1401 South Maryland Drive, Urbana, Illinois 61801

1. VAS Unit 3055, "Lumber: Grading, Selecting, Buying, Using, and Storing."
2. VAS Unit 3041, "Plywood Applications in Farm Construction."
3. VAS Unit 3045, "Metal Roofing and Siding for Farm Structures."

4. VAS Unit 3035, "Applying Asphalt Roofing and Siding Products."
5. VAS Unit 3009a, "Using the Carpenter's Square."
6. VAS Transparencies, "Plywood Construction."
7. VAS Transparencies, "Rafter Marking."
8. VAS Transparencies, "Asphalt Roofing."

## COMPETENCY INVENTORY

### CONSTRUCTING AND MAINTAINING BUILDINGS

1. Student has no knowledge of competency.
2. Student has read about competency.
3. Student has seen competency performed.
4. Student has performed competency.
5. Student has performed competency without supervision.
6. Student does possess skill.
7. Student does not possess skill.

Competency	Circle One						
1. Repair and maintain buildings	1	2	3	4	5		
2. Lay out and construct small buildings	1	2	3	4	5		
3. Follow drawing or blueprints in constructing buildings	1	2	3	4	5		
4. Apply dimensions to drawings	1	2	3	4	5		
5. Figure bill of materials	1	2	3	4	5		
6. Drive and remove nails	1	2	3	4	5		
7. Operate shop hand and power tools	1	2	3	4	5		
8. Select appropriate fasteners	1	2	3	4	5		
9. Select kinds and grades of lumber for a selected job	1	2	3	4	5		
10. Prepare and paint wood surfaces using brush, roller, or spray gun	1	2	3	4	5		
11.	1	2	3	4	5		
12.	1	2	3	4	5		
13. Evaluate existing buildings for repairs or remodeling						6	7
14. Estimate cost of building construction						6	7
15.							

These competencies were outlined in the National Ag Occupations Competency Study, 1978, for entry level positions in agriculture.

Name \_\_\_\_\_ Date \_\_\_\_\_

## INFORMATION SHEET

### INSULATION AND VAPOR BARRIERS\*

#### INSULATING MATERIALS

The effectiveness of a material in resisting heat flow is measured by its Resistance, R. A good insulating material has a high R value.

Commercial insulation is manufactured in a variety of forms and types, each with advantages for specific uses. Materials commonly used for insulation may be grouped in the following general classes: (1) Flexible insulation (blanket and batt); (2) loose-fill insulation; (3) reflective insulation; (4) rigid insulation (structural and nonstructural); and (5) miscellaneous types.

#### FLEXIBLE INSULATION

Flexible insulation is manufactured in two types, blanket and batt. Blanket insulation is furnished in rolls or packages in widths suited to 16- and 24-inch stud and joist spacing. Usual thicknesses are 1½, 2, and 3 inches. Most blanket insulation is covered with paper or other sheet material with tabs on the sides for fastening to studs or joists.

Batt insulation is also made of fibrous material preformed to thicknesses of 4 and 6 inches for 16- and 24-inch joist spacing. It is supplied with or without a vapor barrier.

#### LOOSE FILL INSULATION

Loose fill insulation is usually composed of materials used in bulk form, supplied in bags or bales, and placed by pouring, blowing, or packing by hand. This includes rock or glass wool, wood fibers, shredded redwood bark, cork, wood pulp products, vermiculite, sawdust, and shavings.

#### REFLECTIVE INSULATION

Most materials reflect some radiant heat, and some materials have this property to a very high degree. Materials high in reflective properties include aluminum foil, sheet metal with tin coating, and paper products coated with a reflective oxide composition. Such materials can be used in enclosed stud spaces, in attics, and in similar locations to retard heat transfer by radiation. These reflective insulations are effective only when used where the reflective surface faces an air space at least ¾ inch or more deep. Where a reflective surface contacts another material, the reflective properties are lost and the material has little or no insulating value.

Reflective insulations are equally effective regardless of whether the reflective surface faces the warm or cold side. However, there is a decided difference in the equivalent conductance and the resistance to

heat flow. The difference depends on (a) the orientation of the reflecting material and the dead air space, (b) the direction of heat flow (horizontal, up, or down), and (c) the mean summer or winter temperatures. Each possibility requires separate consideration.

## RIGID INSULATION

Rigid insulation is usually a fiberboard material manufactured in sheet and other forms.

Structural insulating boards, in densities ranging from 15 to 31 pounds per cubic foot, are fabricated in such forms as building boards, roof decking, sheathing, and wallboard. While they have moderately good insulating properties, their primary purpose is structural.

Sheets are made in 2- by 8-foot size for horizontal application and 4- by 8-feet or longer for vertical application.

## MISCELLANEOUS INSULATION

Some insulations do not fit in the classifications previously described, such as insulation blankets made up of multiple layers of corrugated paper. Other types, such as lightweight vermiculite and perlite aggregates, are sometimes used in plaster as a means of reducing heat transmission.

## INSULATION VALUE FACTORS

The insulating value of various building materials is available to help builders determine the type and quantity of insulation to use.

These values are expressed as "k" values or heat conductivity and are defined as the amount of heat, in British thermal units, that will pass in 1 hour through 1 square foot of material 1 inch thick per 1° F. temperature difference between faces of the material. Simply expressed, "k" represents heat loss; the lower this numerical value, the better the insulating qualities.

Insulation is also rated on its resistance or "R" value, which is merely another expression of its insulating value. The "R" value is usually expressed as the total resistance of the wall or of a thick insulating blanket or batt, whereas "k" is the rating per inch of thickness. For example, a "k" value of 1 inch of insulation is 0.25. Then the

resistance, "R" is  $\frac{1}{0.25}$  or 4.0. If there is three inches of this insulation, the total "R" is three times 4.0, or 12.0

## VAPOR BARRIERS

Most building materials are permeable to water vapor. In cold climates during cold weather, this vapor may pass through wall and ceiling materials and condense in the wall or attic space; subsequently, in severe cases, it may damage the exterior paint and interior finish, or even result in decay in structural members. For protection, a material

highly resistive to vapor transmission, called a vapor barrier, should be used on the warm side of a wall or below the insulation in an attic space.

Among the effective vapor-barrier materials are asphalt laminated papers, aluminum foil, and plastic films. Most blanket and batt insulations are provided with a vapor barrier on one side, some of them with paper-backed aluminum foil. Foil-backed gypsum lath or gypsum boards are also available and serve as excellent vapor barriers.

The perm values of vapor barriers vary, but ordinarily it is good practice to use those which have values less than  $\frac{1}{4}$  (0.25) perm. Although a value of  $\frac{1}{2}$  perm is considered adequate, aging reduces the effectiveness of some materials.

\*Source: U.S. Department of Agriculture, Forest Service, Agriculture Handbook Number 73.



STUDENT WORKSHEET 1  
USING LUMBER IN CONSTRUCTION

(Reference VAS Unit 3055)

1. Identify the following parts of the cross section of a tree trunk.

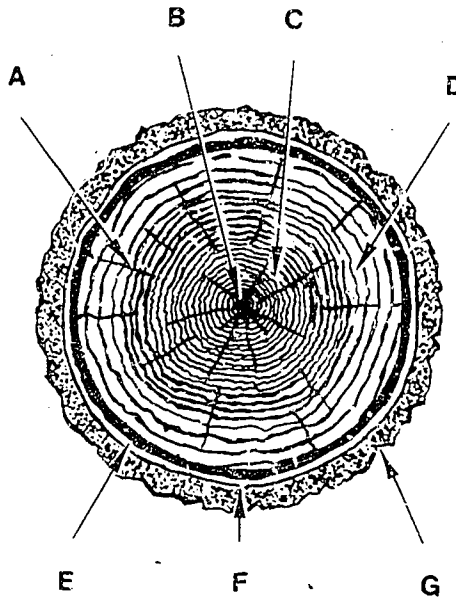

2. Identify the two common methods of cutting boards from logs.

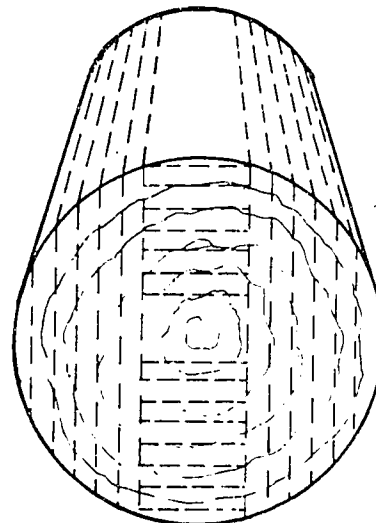
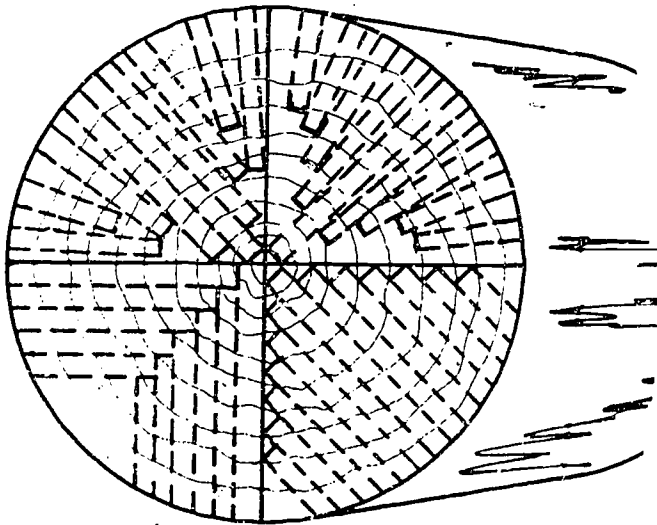

What are the advantages of each method?

3. Wood is classified according to the type of tree from which it is cut. Coniferous (cone-bearing) trees produce \_\_\_\_\_ lumber and deciduous (broad-leaved) trees produce \_\_\_\_\_ lumber.
4. Generally, carpenters use hardwood lumber for \_\_\_\_\_, \_\_\_\_\_, \_\_\_\_\_ and use softwood lumber for \_\_\_\_\_.
5. Identify the following common defects or irregularities found in lumber.



\_\_\_\_\_



\_\_\_\_\_



\_\_\_\_\_



\_\_\_\_\_



\_\_\_\_\_

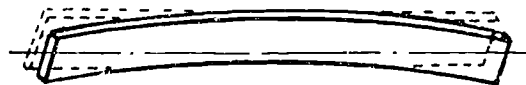

\_\_\_\_\_

6. Define the term "board foot" and give the formula to determine board feet.

7. Using the Board Foot Table, determine the board feet in the following:

<u>Sizes</u>	<u>Board Feet</u>
a. 2"x10"x14' =	_____
b. 4"x4"x18' =	_____
c. 5 boards 1"x10"x12' =	_____
d. 25 boards 2"x6"x8' =	_____

8. How can lumber be kept in top quality before it is used?

9. Identify the common trees growing in your county.

Softwood

Hardwood

10. How can you determine the approximate age of trees?

11. What would happen to a tree if all the bark is cut from the trunk of a tree.

12. What type of lumber is sold by:
- a. board foot:
  - b. square foot or sheet:
  - c. linear foot:
13. Identify some wood working projects which could be done for your home or school.

STUDENT WORKSHEET 2  
USING PLYWOOD IN CONSTRUCTION

(Reference VAS Unit 3042 and transparencies on Plywood Construction)

1. What are some of the major advantages of using plywood in agricultural construction?
2. What determines the "type of plywood"?
3. What does the following Identification Index Number tell about the engineered grade of plywood.

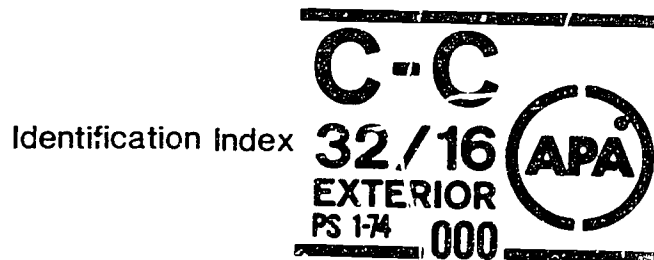

4. What should be the minimum plywood thickness for single wall construction of a utility building with a 24 inch stud spacing and the panels will be placed horizontally for exterior use? (refer to Table 7)

## STUDENT WORKSHEET 3

### PROPER USE OF CARPENTER'S SQUARE

(Refer to VAS Unit 3009a and transparencies on Rafter Marking)

1. If a brace is to fit between two fixed points, what three things must you determine before you cut the brace?
  
2. Name the purposes of the following table found on the carpenter's square.
  - a. Essex Table-
  - b. Brace Table -
  - c. Octagon Scale-
  - d. Rafter Table -
  
3. Name some of the more common types of roofs used on buildings in your local community. Identify the type of roof and the structure on which it was used.

4. Define pitch.
5. Define run.
6. What are the common roof slopes (pitches) used on agricultural buildings in your community?
7. What type of lumber is commonly used for rafters?
8. What is the plate and what does it do?
9. What is the purpose of the overhang?

STUDENT WORKSHEET 4

PARTS OF A BUILDING

Identify all the parts of the building which you can name. Then locate references or use local carpenters to help you identify the remaining parts.

Building A:

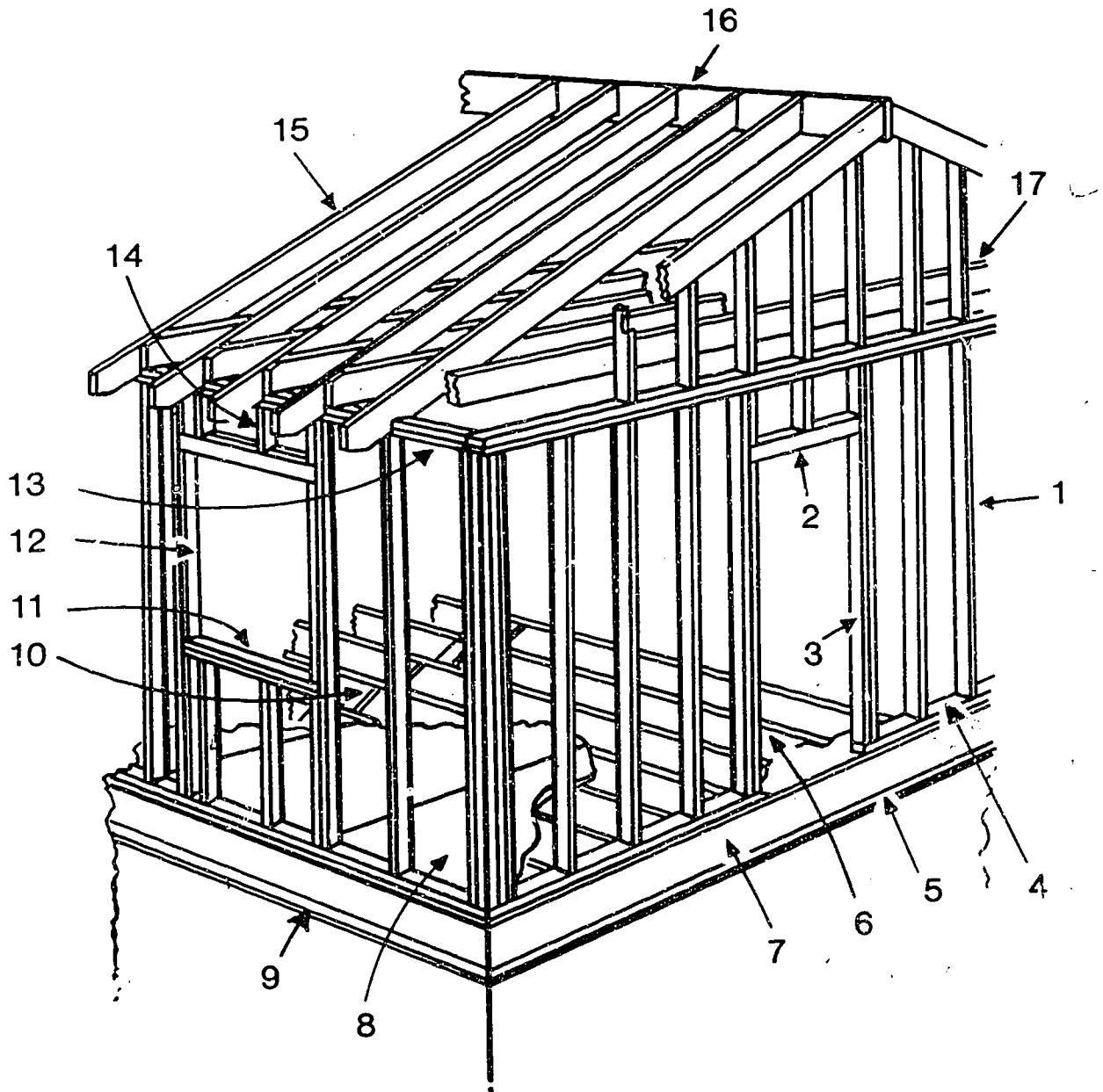



Building B:

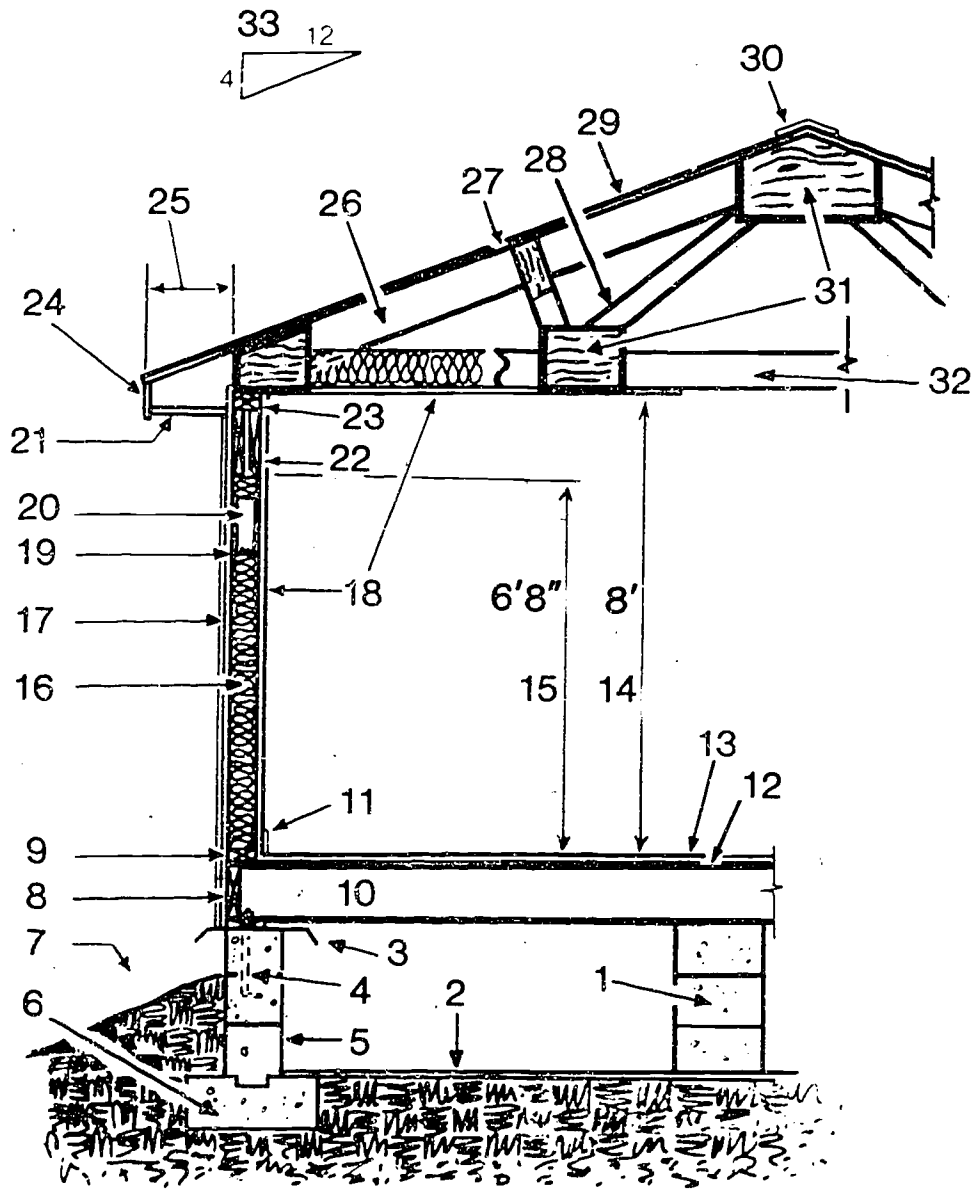

PROJECT PLAN  
CONSTRUCTING A SAWHORSE

OBJECTIVES:

1. To be able to measure and mark lumber to proper dimensions.
2. To be able to use a carpenter's square when determining angles and dimensions.
3. To develop safe work habits in the agriculture laboratory.

MATERIALS:

<u>pieces</u>	<u>dimensions</u>
1	2"x6"x4'
1	2"x4"x10'
1	1"x6"x4'
12	#14x2½" flathead wood screws

carpenter's square  
T-bevel  
hand saw  
wood chisel

PROCEDURE:

1. Mark and cut the 2x4 into four pieces 30" long.

Marking lower end of sawhorse legs

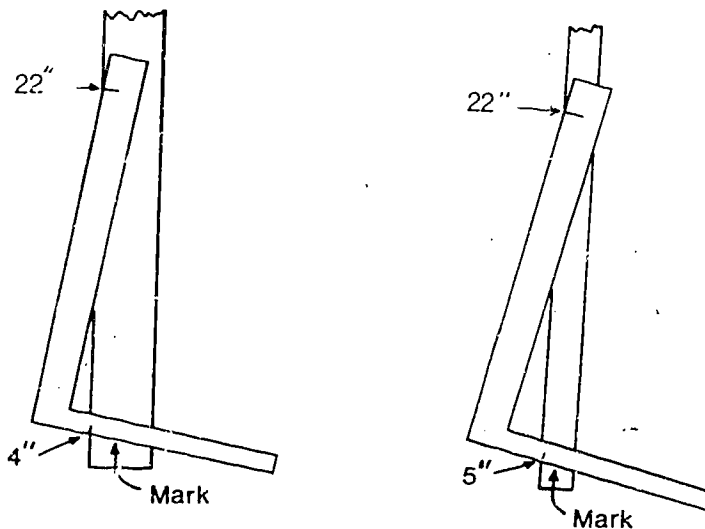

- Using 4" and 22" on the carpenter's square, mark the side of the 2"x4". Then use 5" and 22" on the carpenter's square, mark the edge of the 2"x4".

Marking cutting line

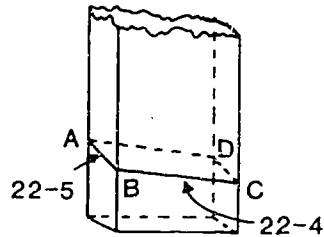

- Use a pencil and straight edge and mark lines AB, BC, CD, and AD around the lower end of the 2"x4" for the leg.
- Mark the other three 2"x4" pieces for the lower end of the legs.

Measuring and marking upper end of sawhorse legs

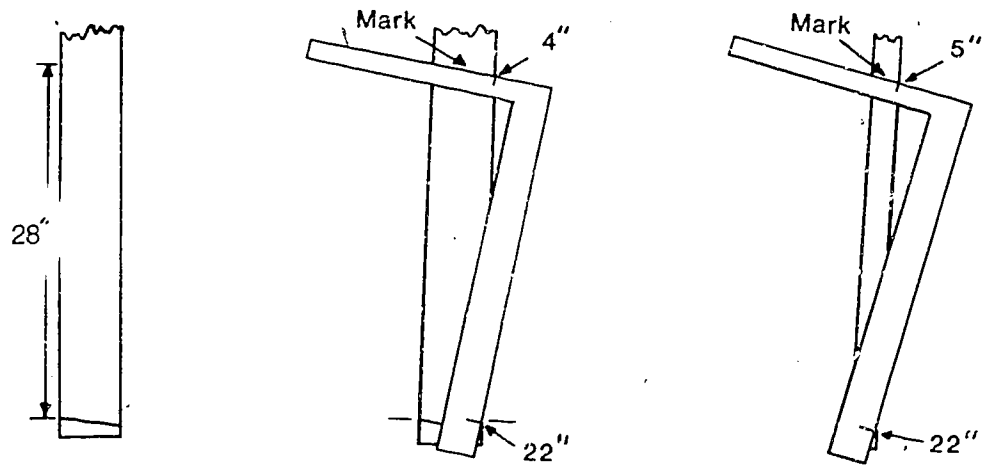

- Measure 28" for the length of the legs. Use the uppermost corner of the lower leg for this measure.
- Mark the upper end of the 4 legs using 4" and 22" on the sides and 5" and 22" on the edges.

- Cut on the waste side of the lines marked on the upper and lower ends of the 2"x4" legs.

Measuring and marking sawhorse legs for back piece

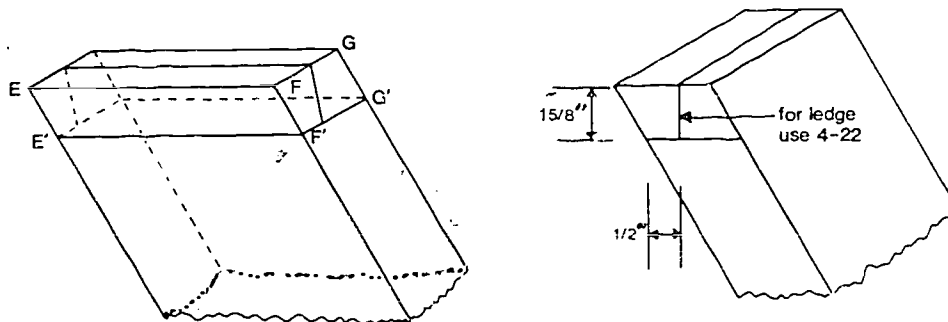

- Mark the upper end of the legs so the back of the saw horse rests on a  $\frac{1}{2}$ " ledge. Be sure to note that there are two opposite pairs of legs. Avoid making all four alike.
- Draw lines E'F' and F'G' parallel to the top edge of the leg and a perpendicular distance (1 5/8") from the end.
- Locate a point on line F'G'  $\frac{1}{2}$ " in from the edge and draw a perpendicular line through this point using 4" and 22" on the carpenter's square. Continue this line across the top and down the other side to line E'G'.
- Mark the notches for all four legs. Position them to check for proper angles on all four legs. Saw out the notches and the legs are complete.
- Mark the 2"x6" board 42" long so the ends are square and cut.
- Mark the notches in the top so the legs will be 4" from the end.

Cutting notches in sawhorse legs and marking back piece

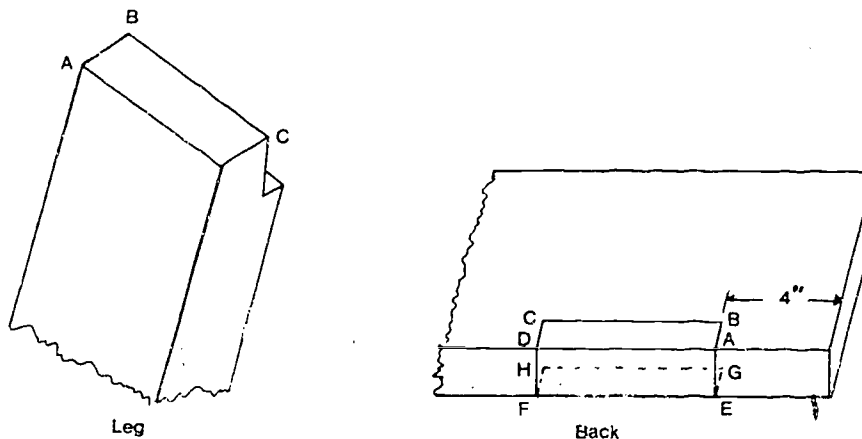

III-H-1-27

14. Lay out the notch in the back so that line AB is 4" from the end and equal in length to AB on the leg. Line BC is parallel to line AD.
15. Lines AE and DF are marked using numbers 4" and 22" on the square.
16. Mark the lines on the underside of the 2"x6" using the same procedure as used on the top side.
17. Lay out the other three notches in the back and check for proper angles.
18. Remove the wood between the lines using a saw and wood chisel. Finish truing the notch with a rasp.
19. Assemble the sawhorse by using three No. 14x2½" flat head wood screws in each leg.
20. Use a countersink and pilot holes to set the screws flush with the surface.

Marking leg braces

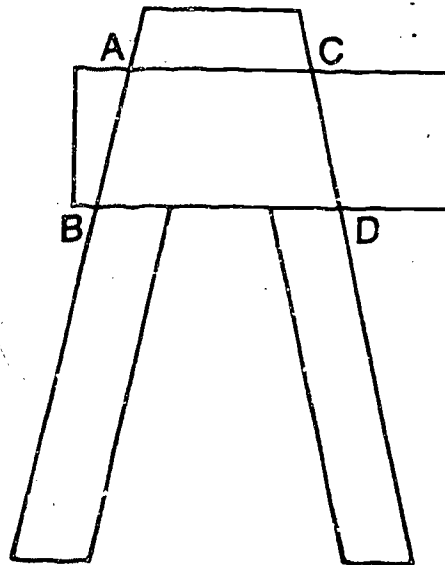

21. Mark end braces so line AC is equal to the distance between the legs just below the back.
22. Mark lines AB and CD using 22" and 5" on the carpenter's square.

23. Cut out the end braces and fasten to the legs using nails or wood screws.

Completed sawhorse

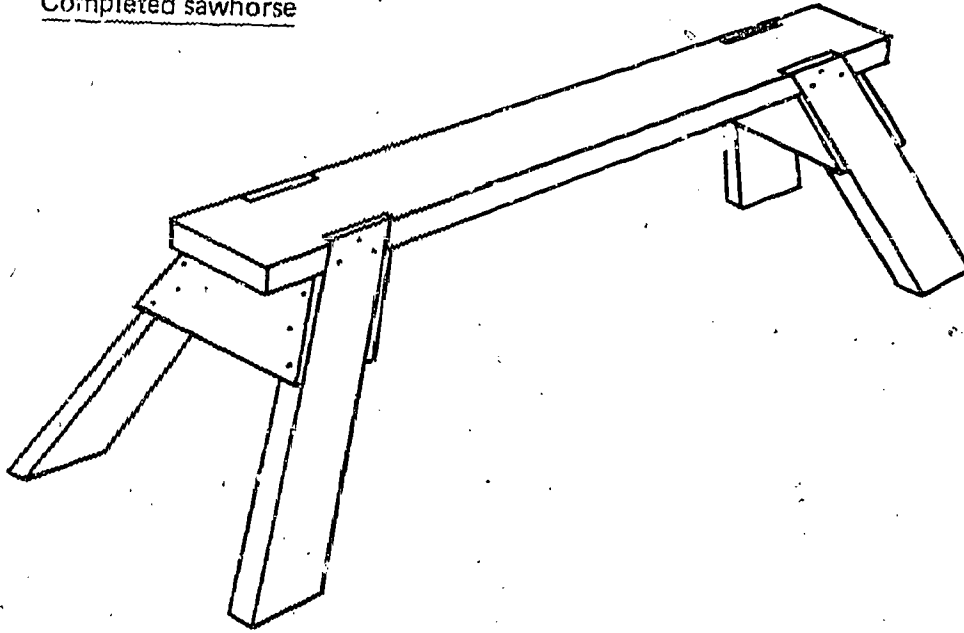

24. The sawhorse is complete. Finish with two coats of paint.

QUESTIONS:

1. What kind of lumber did you use for the sawhorse? \_\_\_\_\_  
\_\_\_\_\_
  2. How many board feet of lumber did you have to purchase?  
\_\_\_\_\_  
\_\_\_\_\_
  3. What would happen if the wood screws were set too close to the edge of the boards? \_\_\_\_\_  
\_\_\_\_\_
- What distance did you set yours from the edge? \_\_\_\_\_  
\_\_\_\_\_

CONCLUSIONS: How can the skills learned in this exercise benefit your S.O.E.P. or homestead?

## PROJECT PLAN

### CONSTRUCTING BARN-TYPE STORAGE SHED

#### OBJECTIVES:

1. To develop the ability to calculate the material needed to construct or repair a building.
2. To develop the ability to estimate the cost of constructing or repairing buildings and structures.
3. To develop the ability to select the proper grades of building materials for various parts of buildings and structures.
4. To develop the ability to understand and interpret building plans.

#### MATERIALS:

<u>QUANTITY</u>	<u>DESCRIPTION</u>	<u>USE</u>
3	4"x4"x12" penta redwood, or crosol runners	Skids under the floor
11	2"x4"x92 5/8" pre-cut studs	Floor joists and end walls
16	2"x4"x12'	Truss members, studs, and top and bottom plates
3	5/8"x4'x8' CDX plywood	Flooring
6	1/2"x4'x8' CDX plywood	Roof sheathing
1	3/8"x4'x8' CDX plywood	Overhang
8	1/2"x4'x8' insulating sheathing panels	Sheathing for exterior walls
13	1"x3"x12'	Trim, fascia
6	3/8"x4'x8' waferboard 90° V-groove siding	Exterior siding
5 lb.	16d coated	Flooring and studing nails
5 lb.	7d galvanized	Siding nails
5 lb.	3/4" galvanized	Roofing nails

<u>QUANTITY</u>	<u>DESCRIPTION</u>	<u>USE</u>
5	10' Metal roof edging	Drip edge
1	15 lb. roll	Saturaged felt underlayment
2 Sq.	235 lb. self-sealing	Asphalt shingles
1½ Gal.	Latex paint	Need ½ gal. for trim
3 Pr.	5½" T-hinges	Door
1	6" Latch and strike	Door
2	Barrel bolt with footchain	Door
1	24" slip head window	Optional
2	Caulking compound tubes	Trim
3	Panel bond tubes (liquid nails, etc.)	Glue joints and gussets

**PROCEDURES:**

**A. Constructing Floor**

Top view of floor assembly

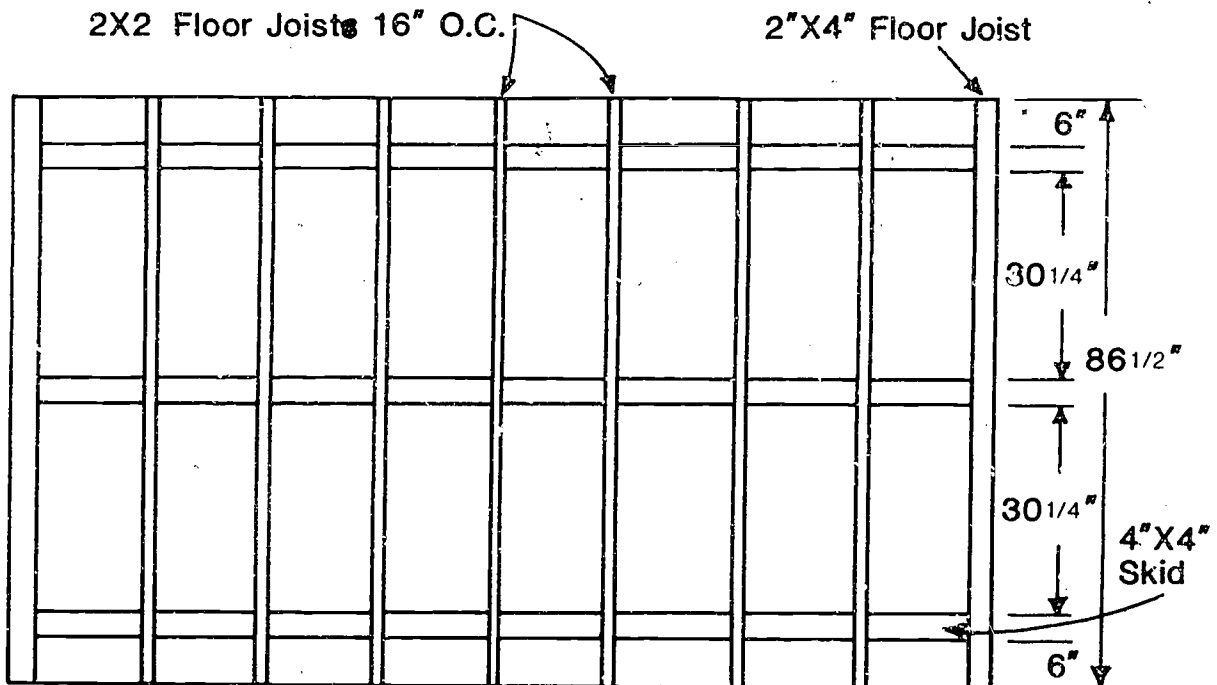



Detail viewing of flooring and skids

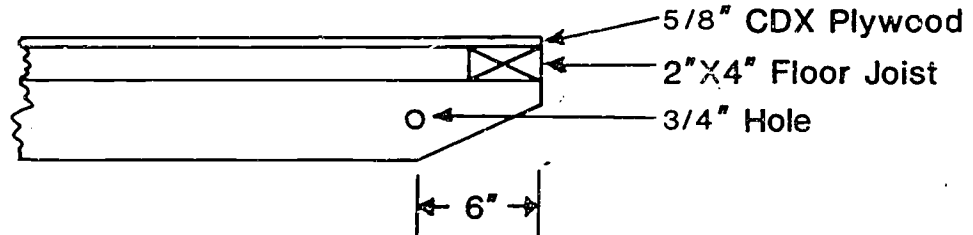

1. Cut 4"x4" skid poles 12' long and level the ends of each.
2. Drill a 3/4" hole 6" from each end of the center 4"x4" skid.
3. Cut 6 of the pre-cut 2"x4" studs to a length of 7'-2½" for the floor joists.
4. Rip 4 of the 6 joints to make (8) 2"x2"x7'-2½" floor joists.
5. Space the 3 skids so there is 72" from the outside of the left skid to the outside of the right skid. Position on center (O.C.) the skid with the holes drilled in each end.
6. Nail the two 2"x4"x7'-½" floor joists flush with each end of the (3) 4"x4"x12' skids. Use 16d nails.
7. Nail the (8) 2"x2"x7'-2½" floor joists to the (3) 4"x4"x12' skids. Place them 16" O.C. Use 16d nails.
8. Cut (3) 5/8" plywood sheets to a length of 7'-2½". Nail the 3 sheets of 5/8" plywood to the floor joists for the floor. Use 8d common nails.
9. The floor is complete.

B. Constructing Side Walls

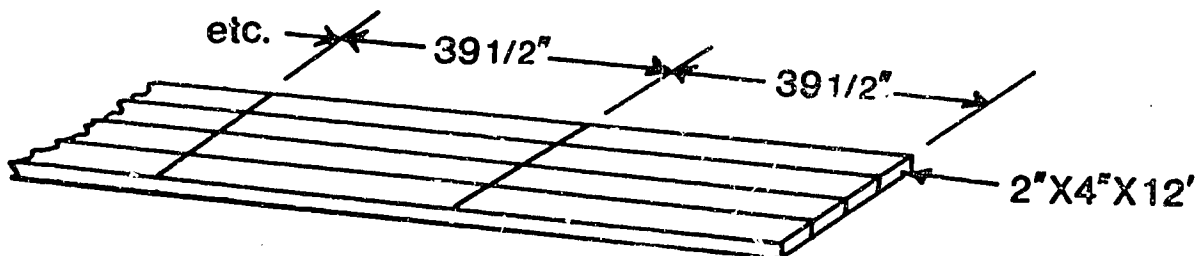

Marking sidewall studs

Marking top and bottom plates for studs

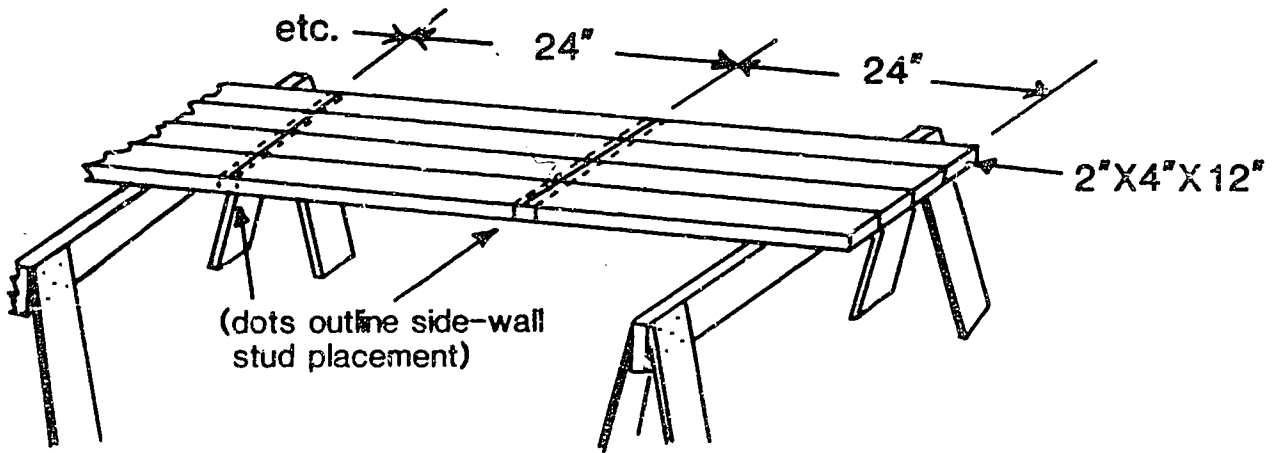

Assembling studs

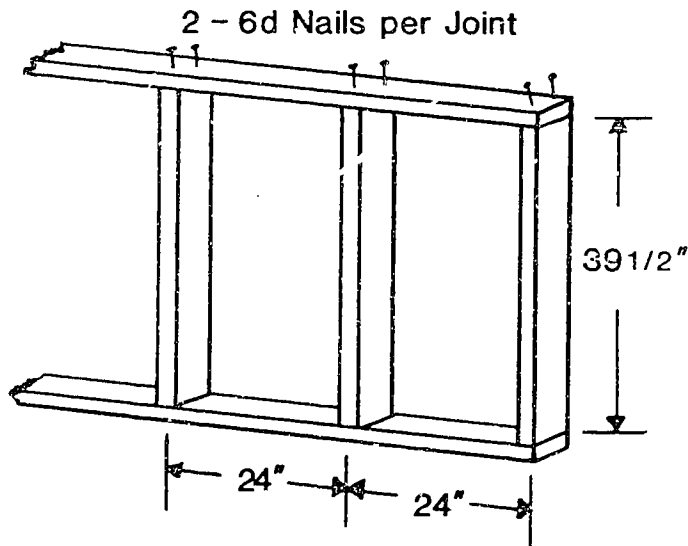

End view of assembled sidewalls

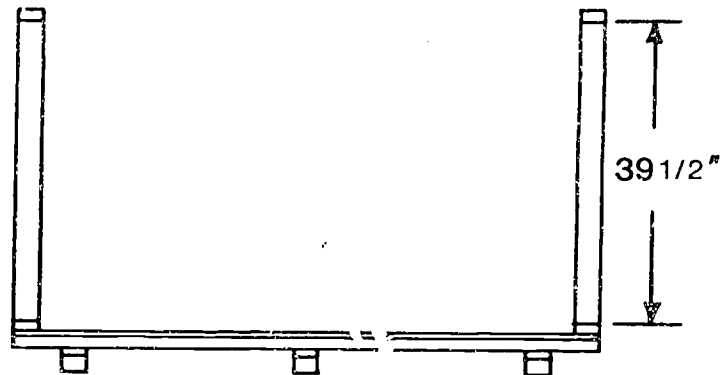

1. Cut (14) 2"x4"x39½" from the 2"x4"x12' boards. These will be the sidewall studs.
2. Cut (4) 2"x4"x12' to exactly 12' long. These will be used for the top and bottom plates.
3. Layout the top and bottom plates on the floor of the building or on sawhorses so all ends are even. Mark the plates so the studs will be 24" O.C.
4. Nail the studs to the top and bottom plates. Use (2) 16d nails per end.
5. Chalk a line 3½" from the edge of the floor. Align sidewall to this line and outside edge of floor and nail lower plate at floor joists. Use (2) 16d nails per joist.
6. The sidewall height should measure almost 48" from the top of the top plate to the bottom of the floor joists.

End view of sidewall showing overhang assembly on top plate

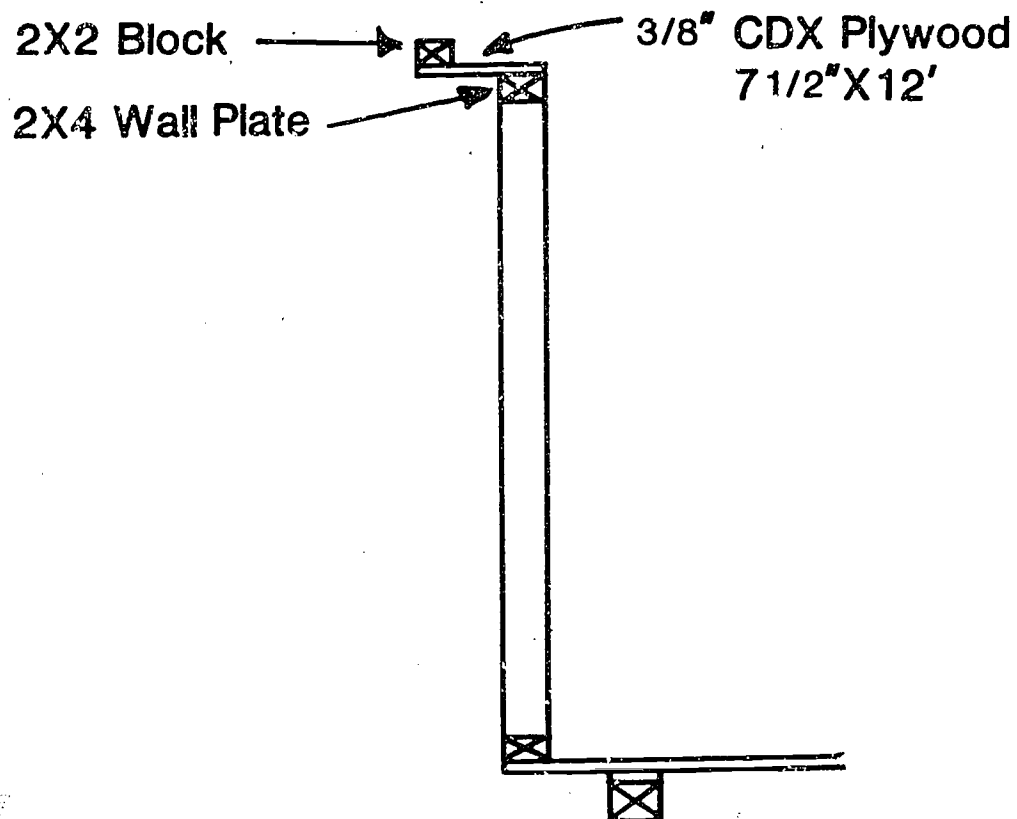

7. Cut (2) pieces of 3/8" plywood to 7½"x12' size. These will be used for the overhang on top of the sidewall plate.
8. Cut (2) 2"x2"x12' for spacers on the outside of the overhang.
9. Nail the 2"x2"x12' spacer to the 3/8"x7½"x12' plywood overhang piece.
10. Nail the 3/8"x7½"x12' plywood overhang with 2"x2"x12' spacer to the top of the sidewall top plate.
11. It may be necessary to use brace boards for additional support of the sidewalls to prevent them from working loose until the end walls and trusses can be attached.

C. Constructing Trusses

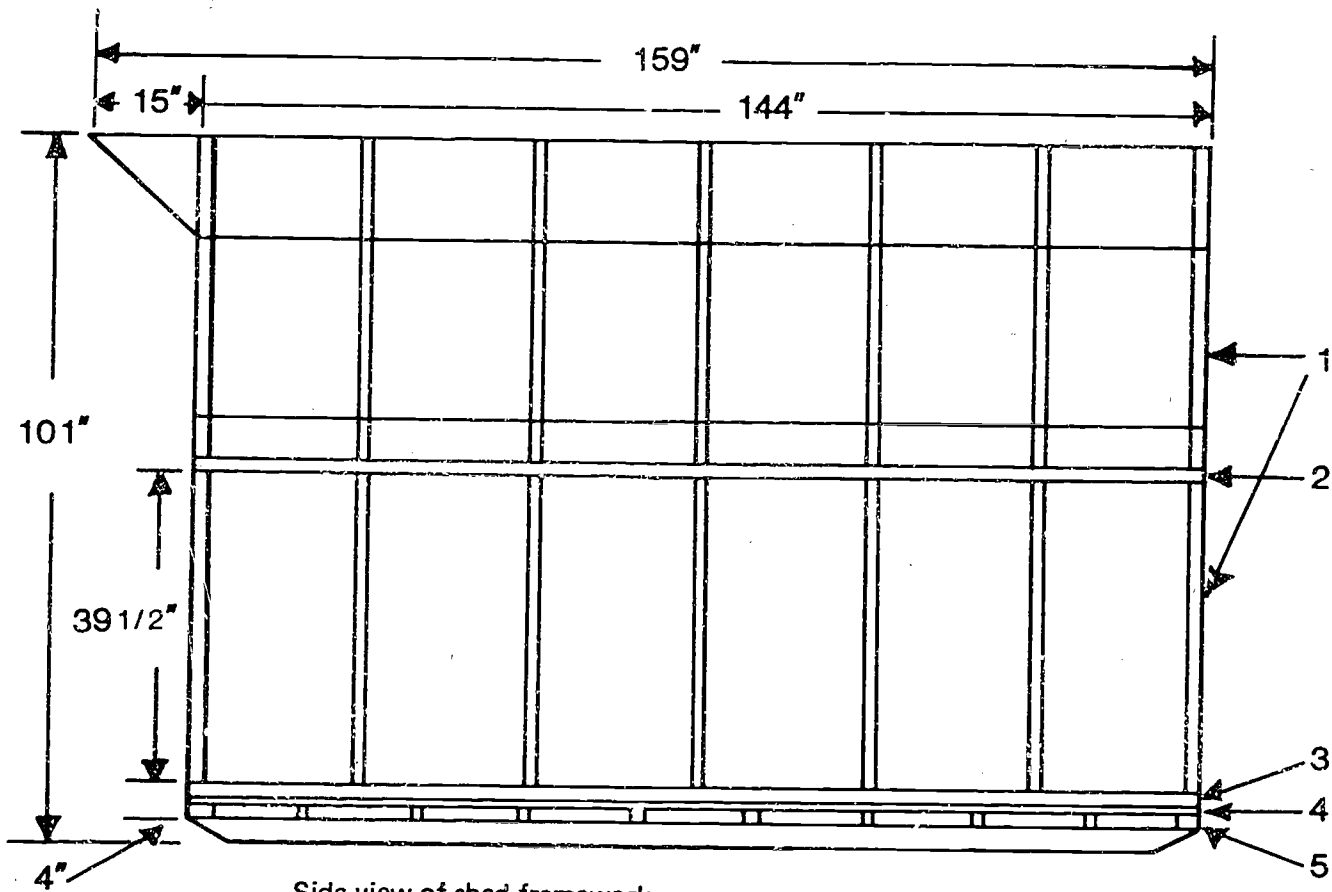

Side view of shed framework

- 1 2"X4" Trusses and Wall Studs at 24" O.C.
- 2 2"X4" Upper Plate
- 3 2"X4" Lower Plate
- 4 5/8" Plywood Flooring
- 5 Floor Joists at 16" O.C.

Constructing trusses using a jig

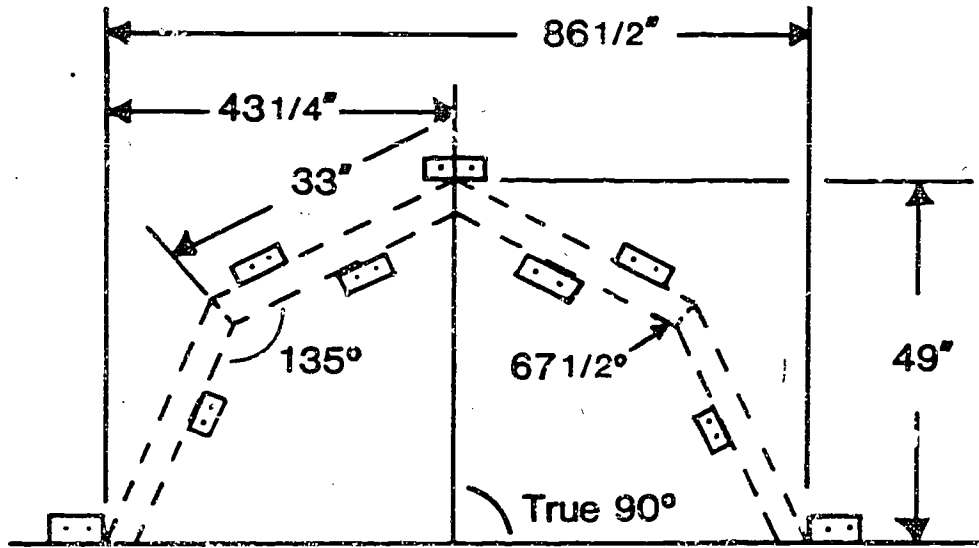

Gussets from scrap



Assembling trusses

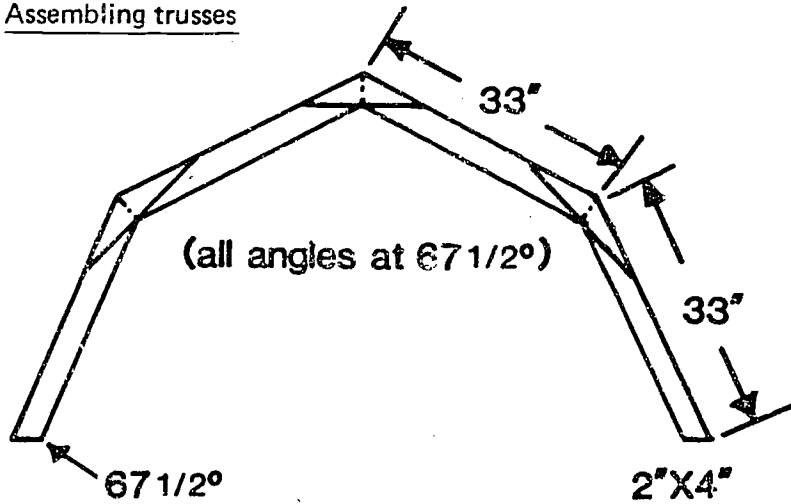

1. Cut (28) 2"x4"x33" using a 22½ degree angle on each end. Cut from (7) 2"x4"x12'.
2. Cut (36) triangular gusset plates from scrap 3/8" and 1/2" plywood. It take (3) gussets for the two end trusses and (6) gussets for the five inside trusses.
3. Place (4) 2"x4"x33" rafters together to form a truss on the floor of the building. Align rafters and measure for correct dimensions. Nail 2"x4" scrap blocks to floor to form a jig for holding truss as it is glued and nailed.
4. Glue and nail gusset strip over each splice. Remember the two outside trusses have gussets only on one side.
5. Nail trusses to sidewalls 24" O.C. Align over studs in sidewalls.

D. Constructing Wall and Roof Sheathing

Positioning sheathing panels on roof sections

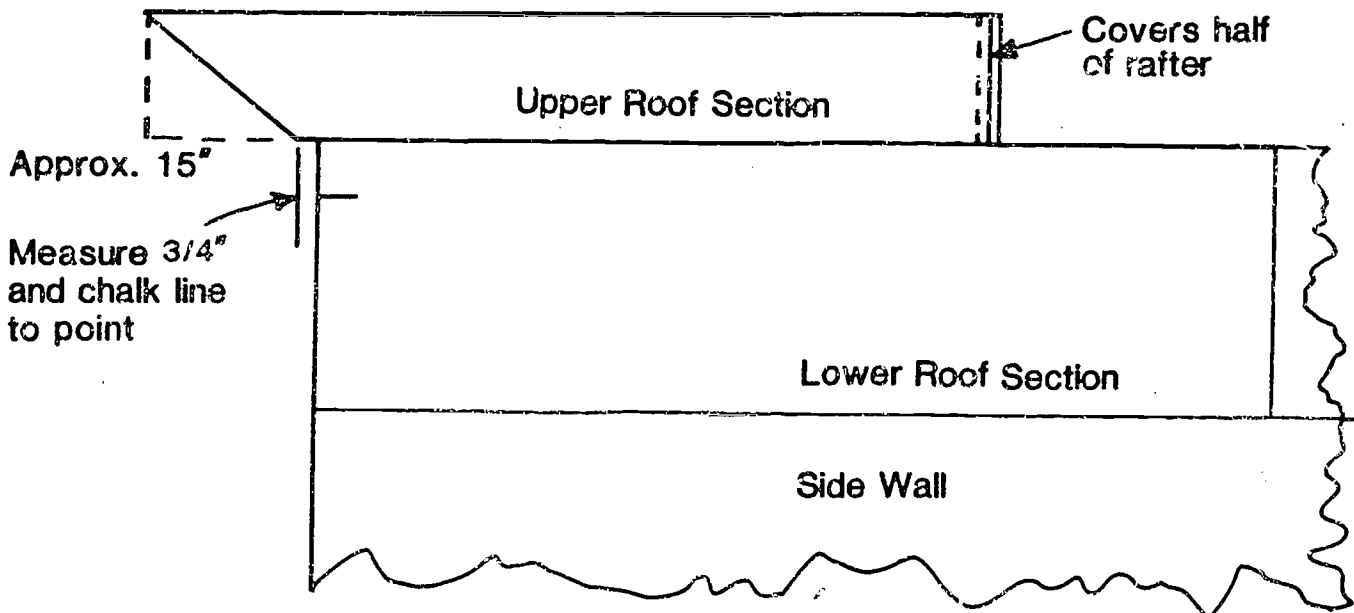

End view of roof sheathing

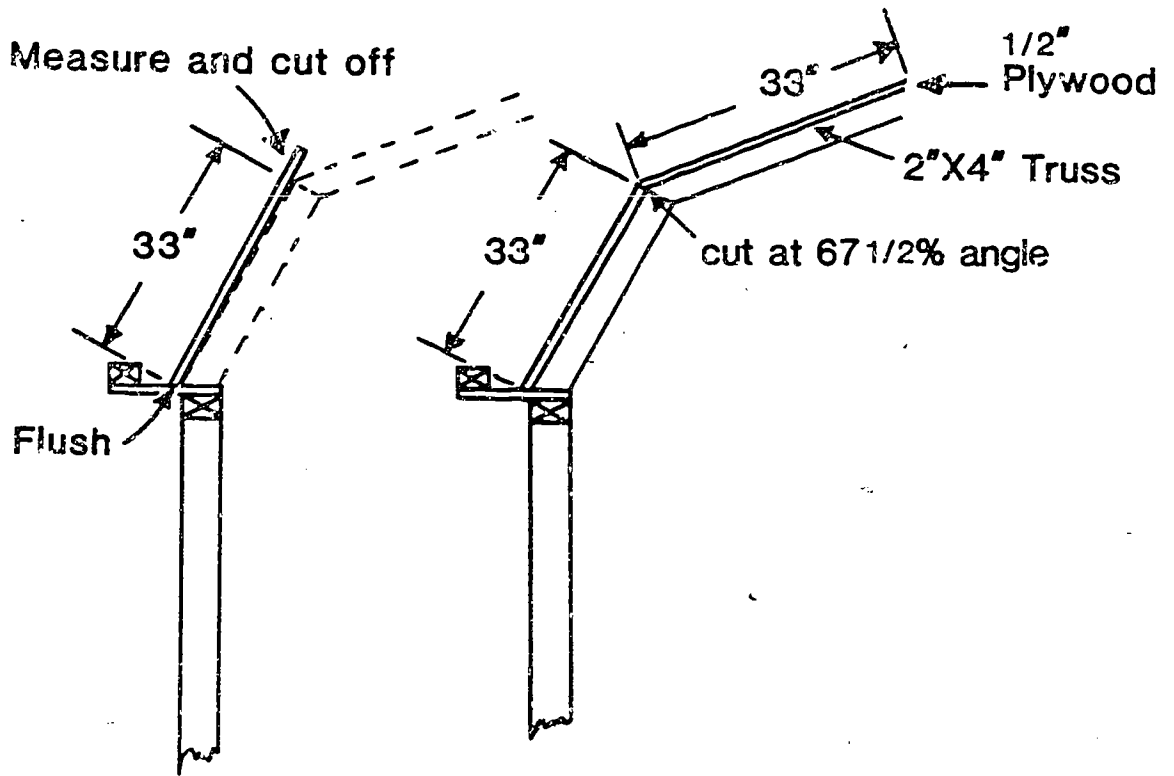

Side view of roof sheathing

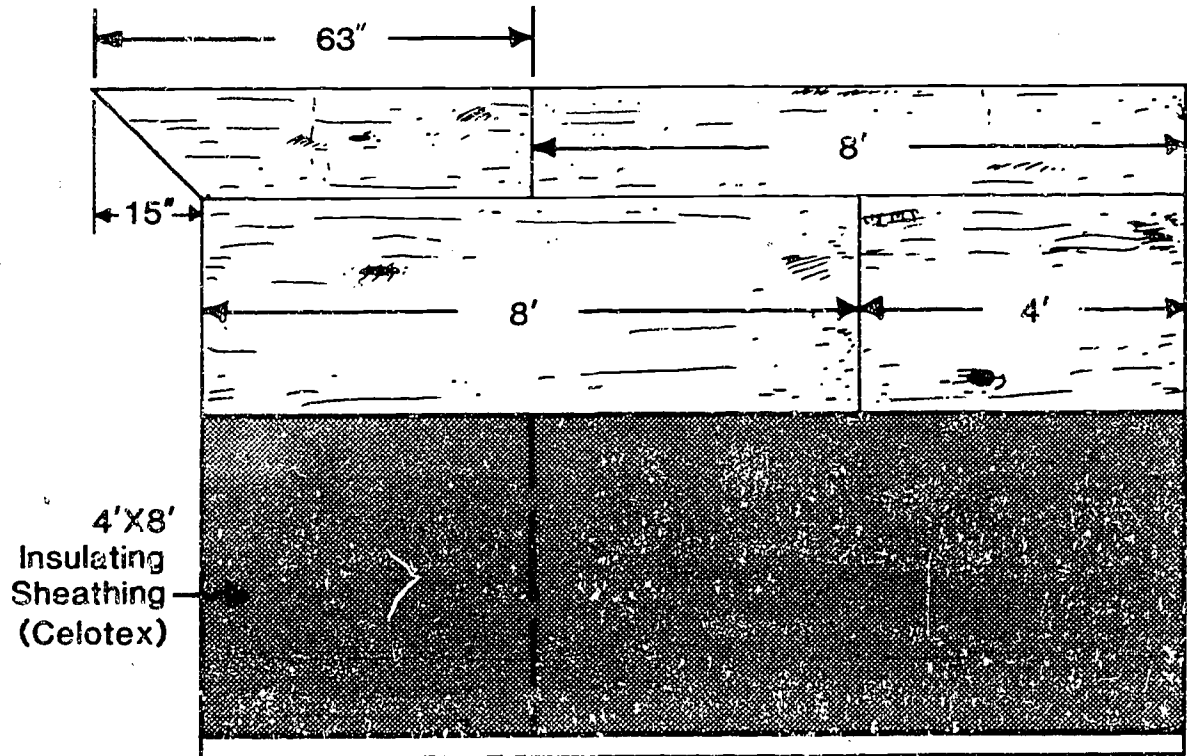

1. Rack the wall panels until the diagonals measure the same. This squares the wall panels.
2. Apply  $\frac{1}{2}$ " insulating sheathing to squared wall panel. Use  $1\frac{1}{2}$ " galvanized roofing nails.
3. Install rough openings in end walls using 2"x4" lumber for door and window (window is optional).

Positioning roof sheathing for nailing

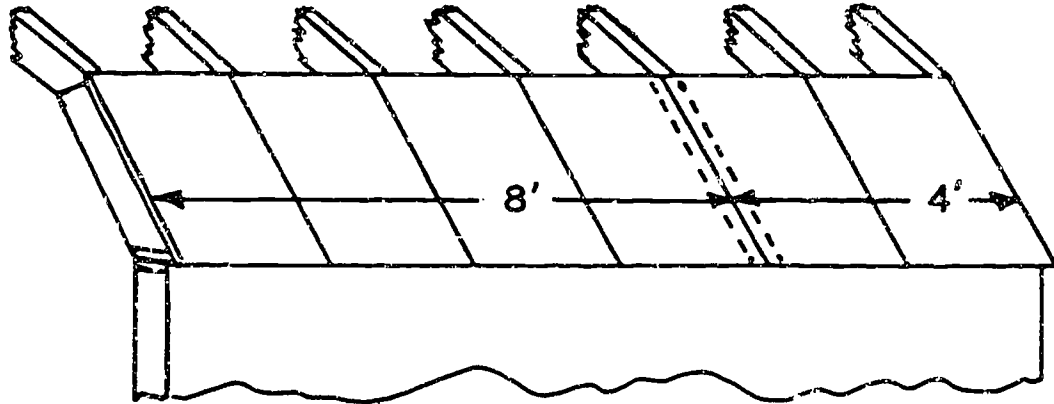

Front view with door framing

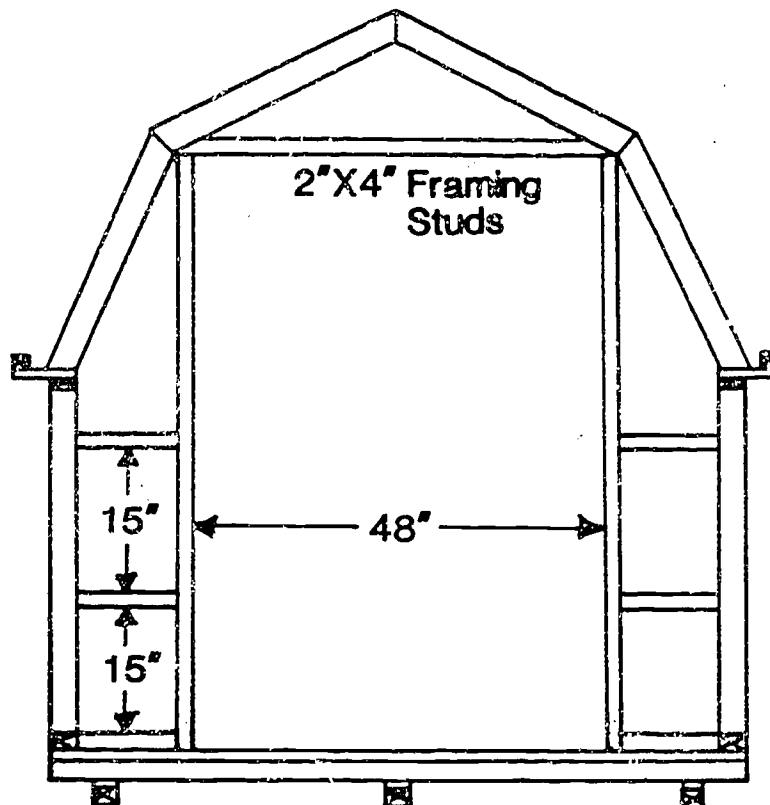



4. Apply  $\frac{1}{2}$ " insulating sheathing to end walls.
5. Apply roof sheathing using (4) pieces of  $\frac{1}{2}$ " CDX plywood ripped 33" wide and 8' long, (2) pieces ripped 33" wide and 4' long, and (2) pieces 33" wide and 63" long (these last two are for the top section at peak). The sheathing pieces could be re-dimensioned to allow for overhang on front and back (optional).
6. Apply peak over doors. The front top roof sheathing pieces should be cut for the peak before final nailing. Make sure all trusses are square before fastening sheathing. Chalk line sheathing to locate trusses for nailing.

Back view with window framing

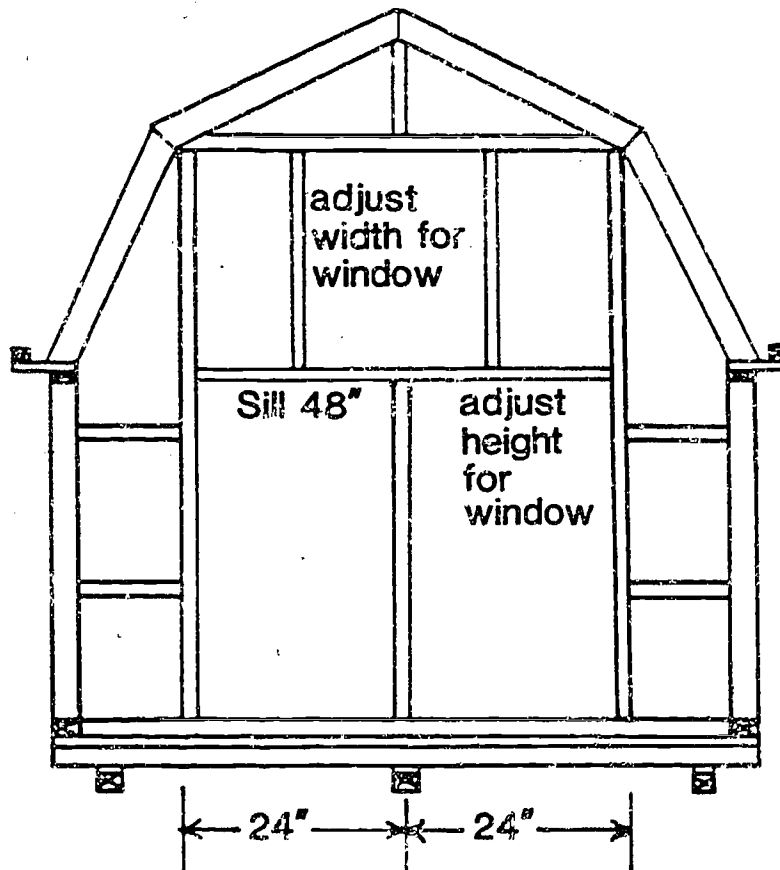

- Cut strips of  $\frac{1}{2}$ " CDX plywood 7" wide using about 23 degree angle for lower roof sheathing angle on overhang.

End view with lower roof angle on overhang

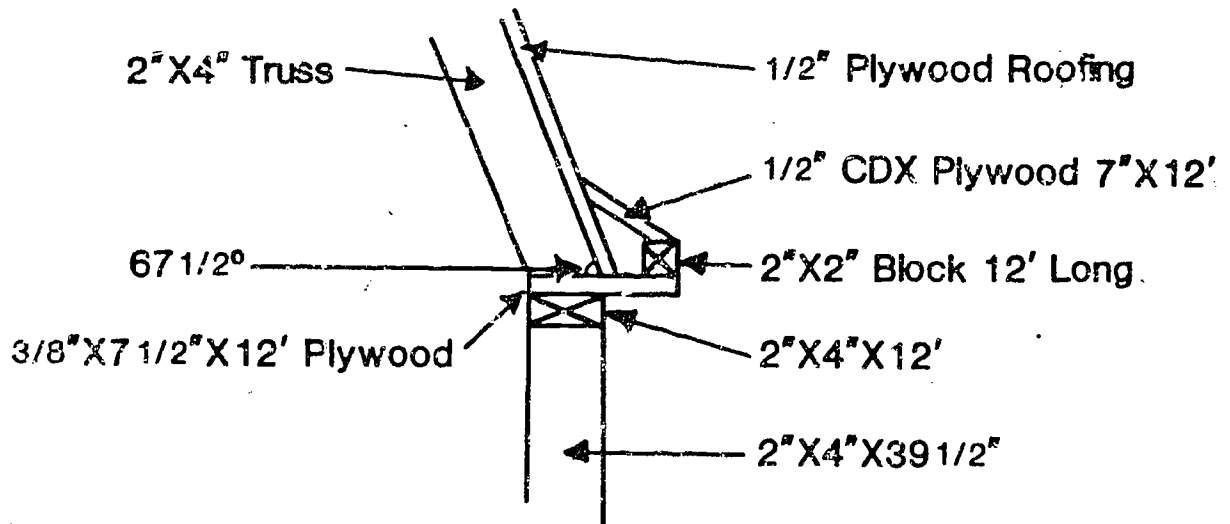

- Install and frame window.

#### E. Applying Trim

- Carefully measure, cut and install V-groove siding. Use 7d galvanized siding nails.
- Apply 1"x3" trim to all exposed corners and inside corners. Use 7d galvanized siding nails.
- Miter at 45 degrees all joints where trim meets end to end.
- Caulk all joints.
- Rip a  $\frac{1}{2}$ "x4'x8' sheet of AC plywood  $1\frac{1}{2}$ " off center lengthwise. These two pieces will be used to make the doors.

Top view of door

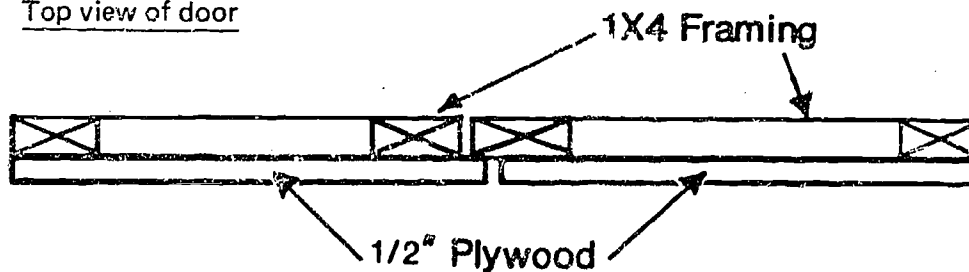

Front view of door

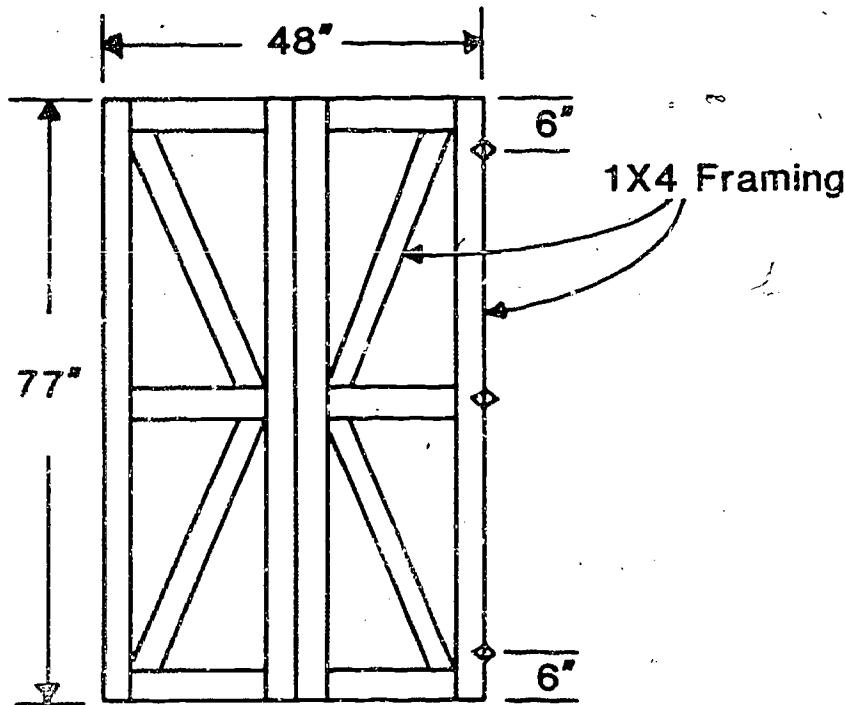

6. Apply trim and siding to doors and caulk. Install doors and latches. Install door stops and plan door edges for proper fit. Door stops can be made by ripping 1"x3" boards in half. Allow at least 1/8" clearance on doors for swelling due to moisture.

F. Installing Roof

1. Apply 15 lb. felt paper. Beginning at lower edge of roof and working toward peak. Cut first strip in half and use it on each side as a starter strip.
2. Over-lap each strip by 3 to 4 inches and staple with 3/8" staples. Remove all wrinkles before fastening.

Applying underlayment

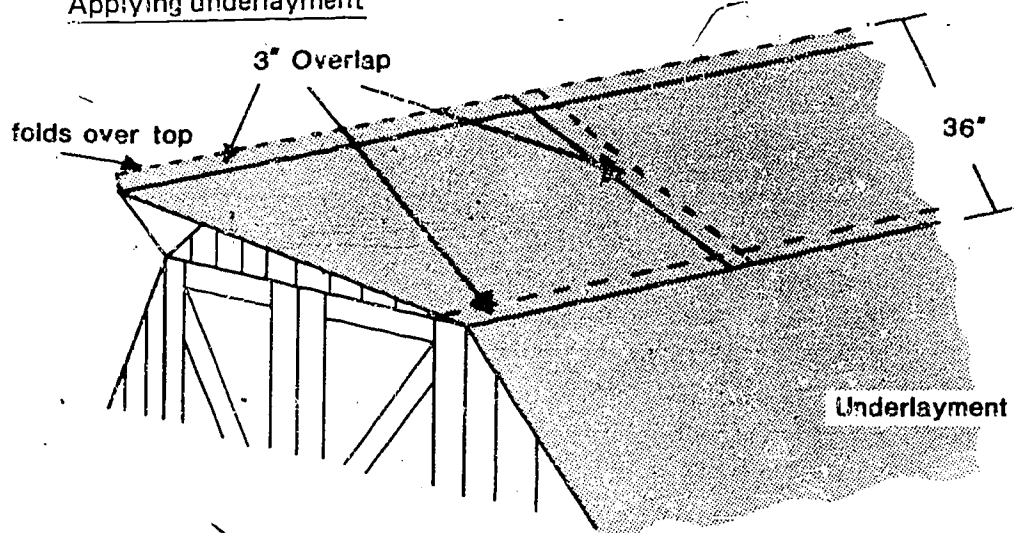

3. Apply metal edging. Use 3/4" roofing nails.
4. Apply first course of shingles upside down to serve as a starter strip.

Positioning nails on shingles

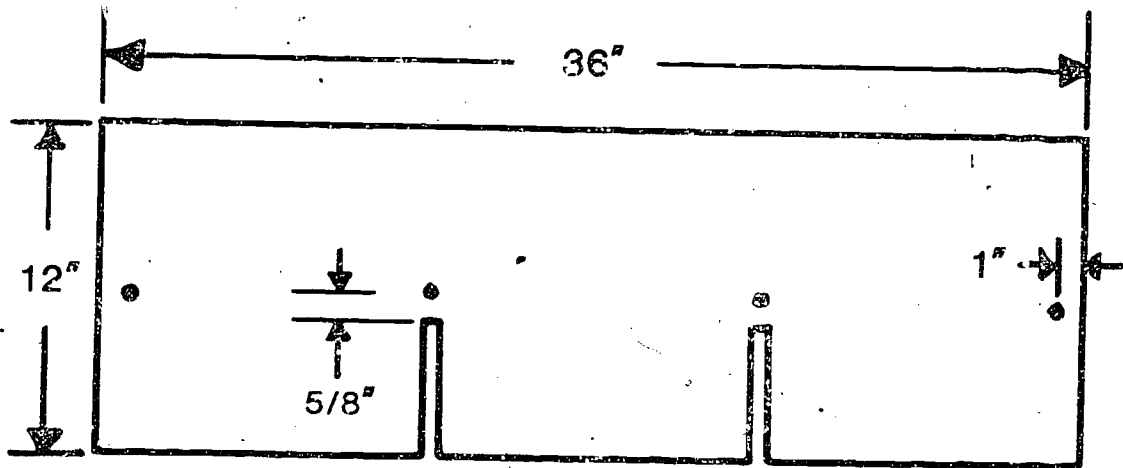

Side view of lower panel (not shown to scale) shingle positioning on roof

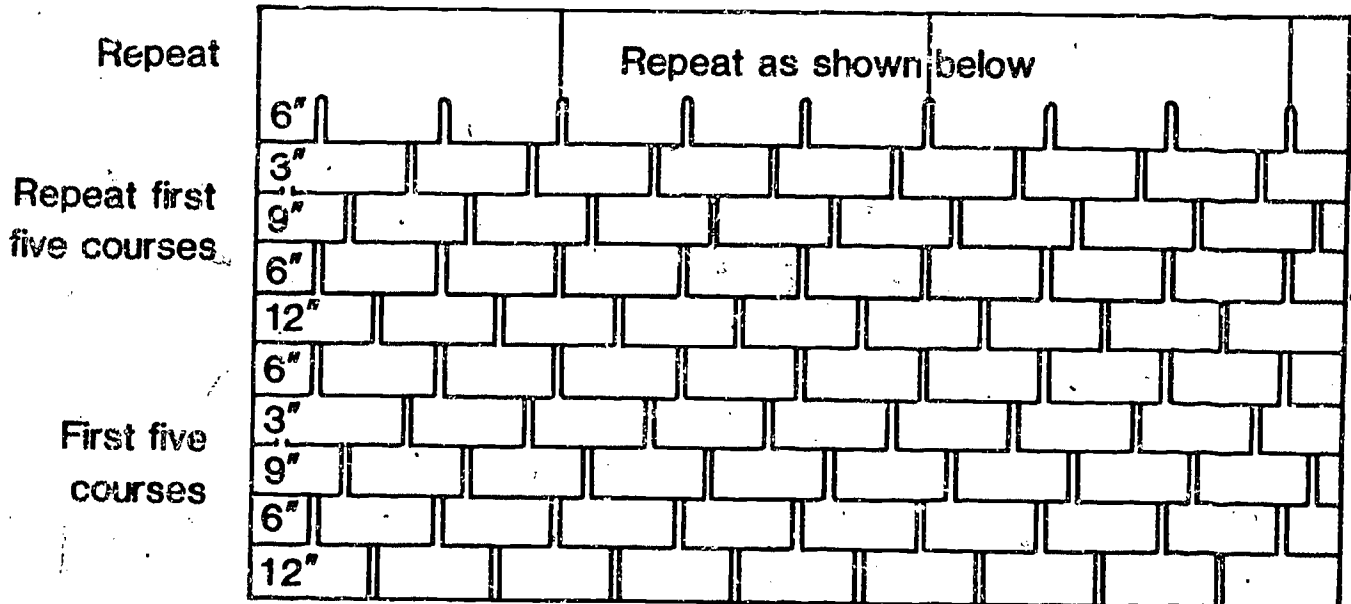

**Lower Panel (not shown to scale)**

5. Read and follow directions on shingles package. Apply shingles using 3/4" galvanized roofing nails.

Applying and fastening roofing materials

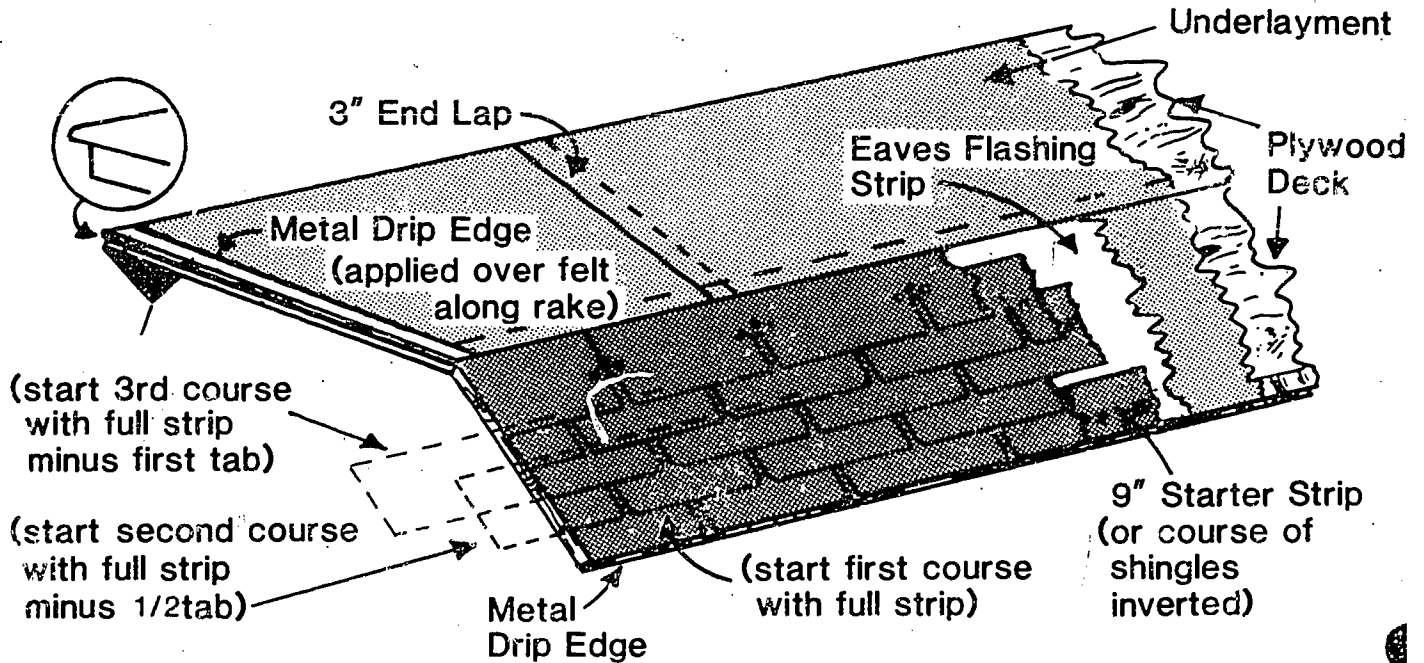

6. Cut shingles into thirds, at tab, for roof peak covering.
7. Trim shingles neatly on the ends of building being careful not to tear them.

G. Applying Paint

1. Clean all surfaces of dust and dirt.
2. Paint all large surfaces with major color.
3. Paint all trim with highlight color.
4. Building may need two coats of paint.

H. Evaluating Building

1. Inspect entire building and make sure everything is complete and satisfactory.

2. Complete materials list and calculate value of building.
3. Optional - could install electrical wiring and receptacles inside building.

Completed shed

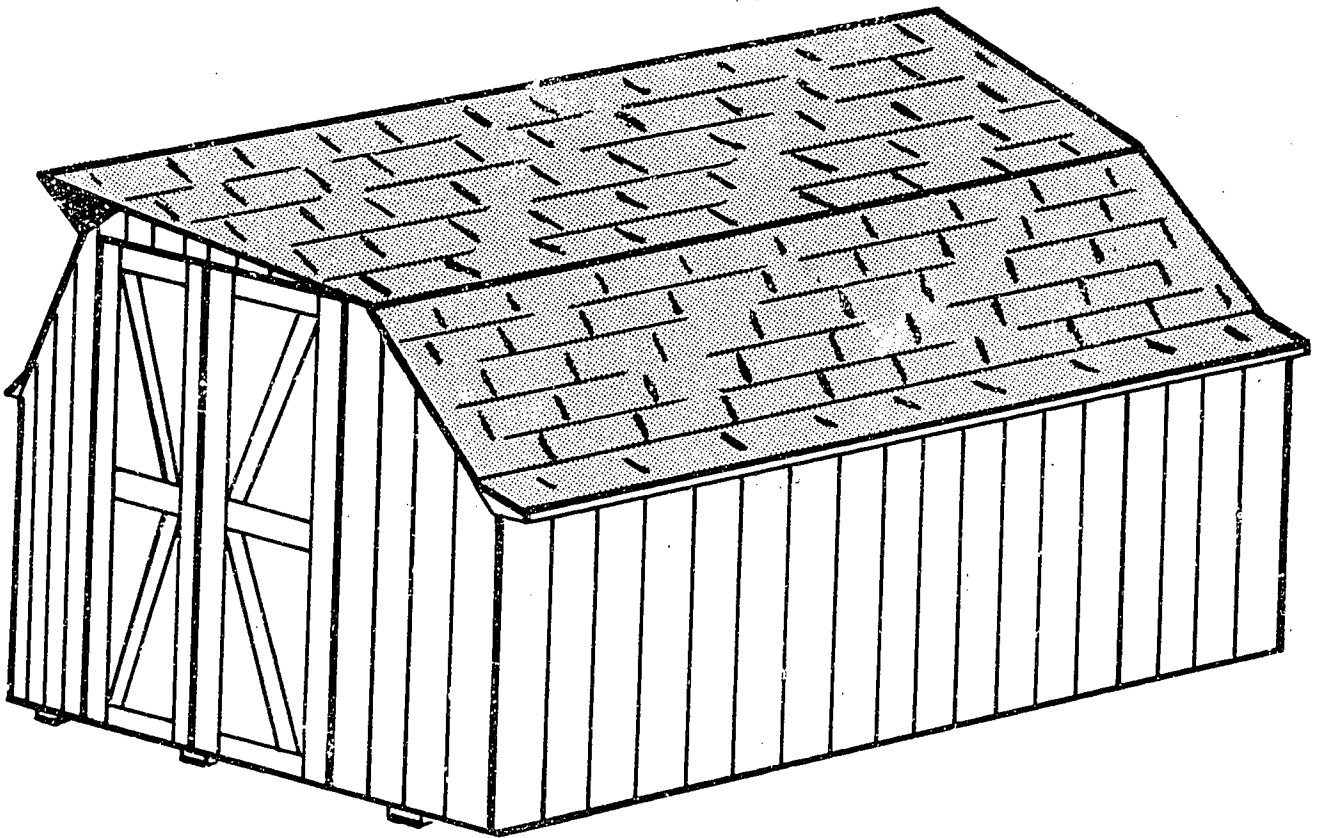

## STUDENT JOB SHEET

### BILL OF MATERIALS

- I. Identify a construction project to recondition or build and complete the following assignment.
- II. Assignment:
  - a) Make a bill of materials for the project indicated. Use standard "rules of thumb" for estimating the quantities of materials.
  - b) Specify the grade of material for each item.
  - c) Calculate the cost of the materials from the current prices supplied.
  - d) Calculate time spent on job.
  - e) Calculate value of material.
  - f) Calculate value of completed job.
  - g) Calculate value added by labor.

BILL OF MATERIALS LIST

Number	Size	Description	Grade	Quantity (bd. ft., sq. ft.)	Unit cost	Total cost



TEACHER'S KEY  
STUDENT WORKSHEET 1  
USING LUMBER IN CONSTRUCTION

(Reference VAS Unit 3055)

1. Identify the following parts of the cross section of a tree trunk.

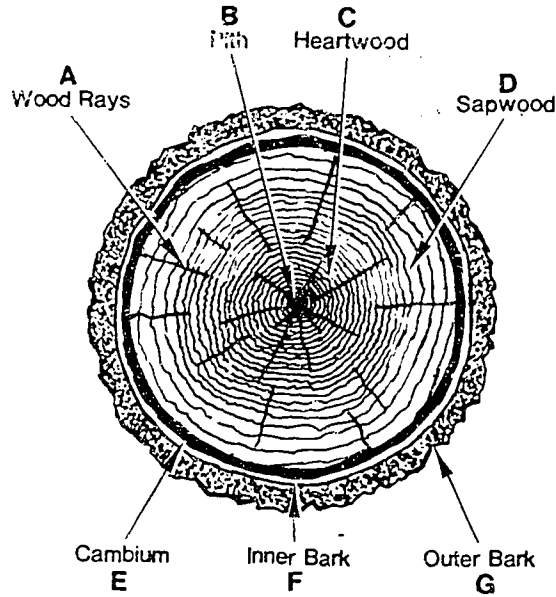

2. Identify the two common methods of cutting boards from logs.

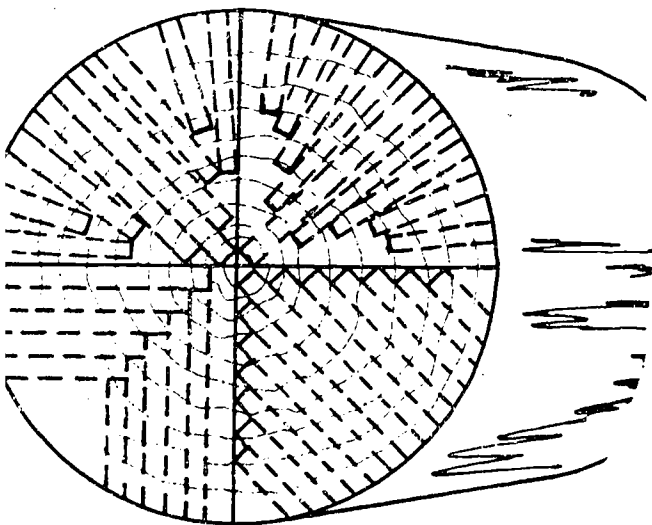

Quarter-sawed

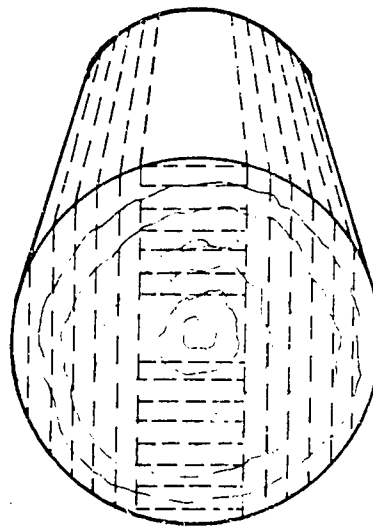

Plain-sawed

What are the advantages of each method?

Plain-sawed: cheaper, easier to kiln dry, produce wider boards.

Quarter-sawed: less tendency to warp, shrink, and swell, more durable, holds finish better, prettier grain.

3. Wood is classified according to the type of tree from which it is cut. Coniferous (cone-bearing) trees produce softwood lumber and deciduous (broad-leaved) trees produce hardwood lumber.
4. Generally, carpenters use hardwood lumber for furniture, cabinetry, flooring, etc. and use softwood lumber for general building construction, subflooring, fencing, etc.
5. Identify the following common defects or irregularities found in lumber.



Knot



Cross grain



Shake



Check



Wane

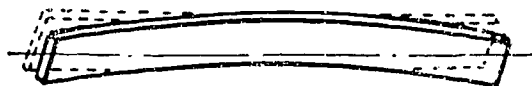

Bow

6. Define the term "board foot" and give the formula to determine board feet.

$$\text{Board feet} = \text{number of boards} \times \frac{T'' \times W'' \times L'}{12}$$

(If the length is in inches instead of feet divide by 144.)

7. Using the Board Foot Table, determine the board feet in the following:

<u>Sizes</u>	<u>Board Feet</u>
a. 2"x10"x14' =	<u>23 1/3</u>
b. 4"x4"x18' =	<u>24</u>
c. 5 boards 1"x10"x12' =	<u>50</u>
d. 25 boards 2"x6"x8' =	<u>200</u>

8. How can lumber be kept in top quality before it is used?

Do not order far in advance, keep it neatly stacked using spacers for air circulation, keep level, off the ground and covered.

9. Identify the common trees growing in your county.

Softwood

Hardwood

10. How can you determine the approximate age of trees?

By counting the number of growth rings in the cross section of a freshly cut tree near ground level.

11. What would happen to a tree if all the bark is cut from the trunk of a tree.

The tree would die because the cambium layer would be damaged and the xylem and phloem cell layers could not transport water and food.

12. What type of lumber is sold by:

- a. board foot: Most all construction lumber which has been worked or dressed.
- b. square foot or sheet: Plywood, particle board, and paneling, etc.
- c. linear foot: Moldings, trim, and some siding materials.

13. Identify some wood working projects which could be done for your home or school.

TEACHER'S KEY  
STUDENT WORKSHEET 2  
USING PLYWOOD IN CONSTRUCTION

(Reference VAS Unit 3042 and transparencies on Plywood Construction)

1. What are some of the major advantages of using plywood in agricultural construction?
  - a. Structural strength
  - b. Durability
  - c. Low cost
  - d. Little waste
  - e. Good insulation
  - f. Convenient and available
  - g. Good workability
  - h. Good finishing properties
  - i. Resists expansion and contraction
2. What determines the "type of plywood"?
  - a. Their resistance to moisture.
  - b. The kind of glue used.
  - c. The veneer grades.
  - d. The manufacture techniques.
3. What does the following Identification Index Number tell about the engineered grade of plywood.

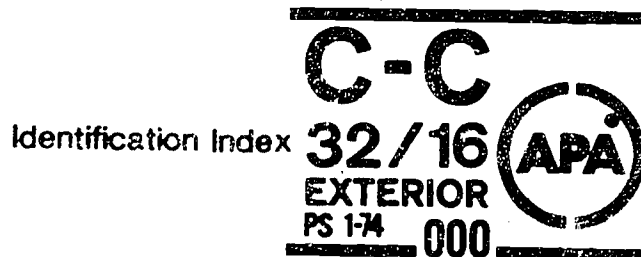

The number on the left indicates the maximum recommended spacing for roof supports in inches.

The number on the right indicates the maximum recommended spacing for subflooring supports.

4. What should be the minimum plywood thickness for single wall construction of a utility building with a 24 inch stud spacing and the panels will be placed horizontally for exterior use? (refer to Table 7)

Use plywood which is no thinner than 3/8".

## TEACHER'S KEY

### STUDENT WORKSHEET 3

#### PROPER USE OF CARPENTER'S SQUARE

(Refer to VAS Unit 3009a and transparencies on Rafter Marking)

1. If a brace is to fit between two fixed points, what three things must you determine before your cut the brace?
  - a. The rise of the brace.
  - b. The run of the brace.
  - c. The total length of the brace.
  
2. Name the purposes of the following table found on the carpenter's square.
  - a. Essex Table- Used to determine the number of board feet in a board of any common width and length.
  - b. Brace Table - Used to determine the length of common braces.
  - c. Octagon Scale- Used to construct an octagon or 8-sided figure.
  - d. Rafter Table - Used in laying out all kinds of rafters, braces, and other building members which require angle cuts.
  
3. Name some of the more common types of roofs used on buildings in your local community. Identify the type of roof and the structure on which it was used.

4. Define pitch.

Pitch is the roof slope as determined by the inches of rise per foot of run. For example, 6/12 slope means there is a 6 inch rise per foot of run.

5. Define run.

The distance between the outer edge of the plates divided by two.

6. What are the common roof slopes (pitches) used on agricultural buildings in your community?

7. What type of lumber is commonly used for rafters?

Softwoods, such as white pine, etc.

8. What is the top plate and what does it do?

It's the horizontal piece of lumber pieced along the upper end of the walls. It supports the rafters.

9. What is the purpose of the overhang?

It helps to form the eaves or cornice and this helps shed the water away from the walls and buildings. It also shades the side of the house and prevents the entrance of direct summer solar rays.

TEACHER'S KEY  
STUDENT WORKSHEET 4  
PARTS OF A BUILDING

(Refer to transparencies on building parts and local building trade booklets and local carpenters)

Building A:

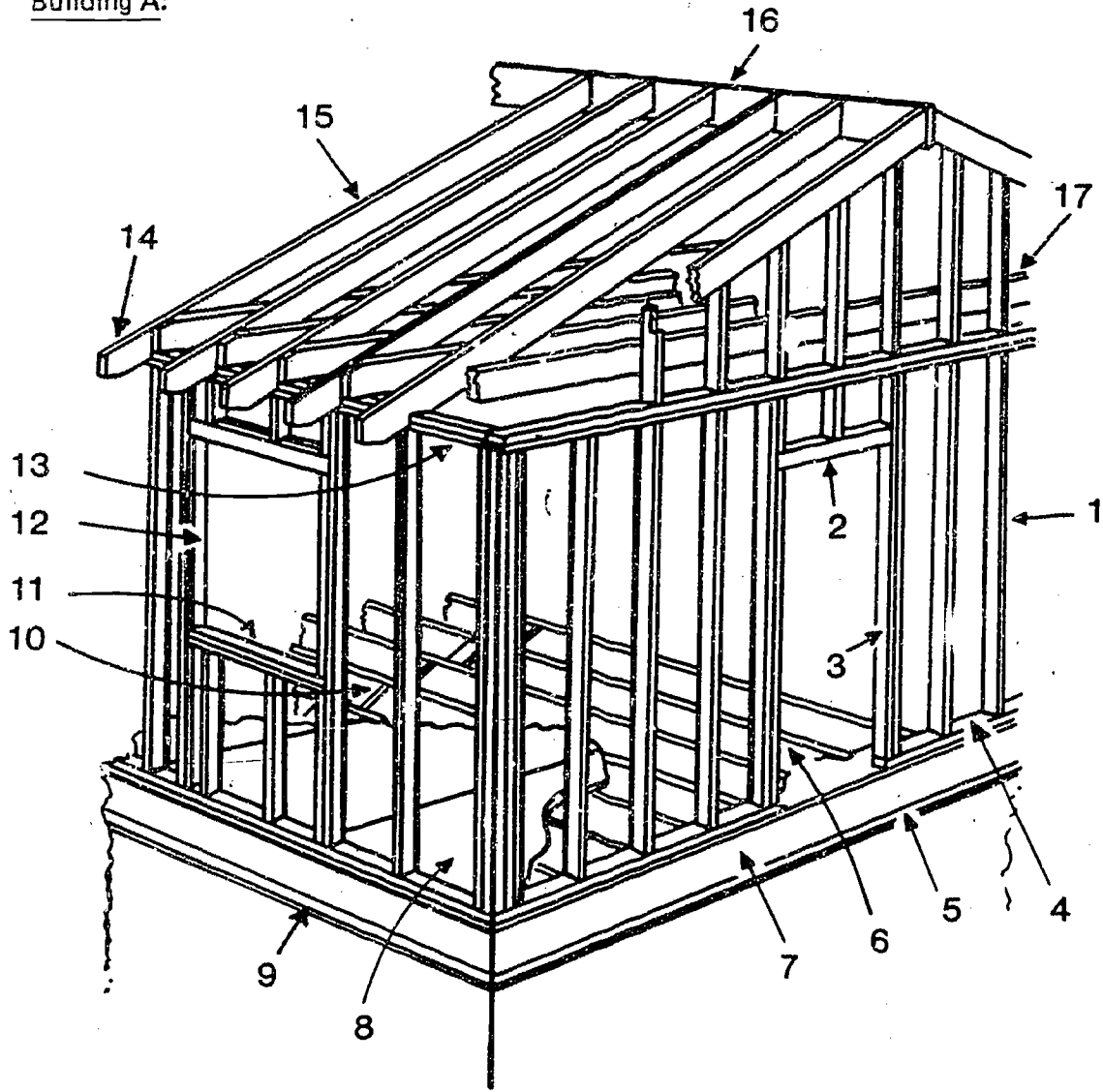

- |                                 |                       |                                |
|---------------------------------|-----------------------|--------------------------------|
| 1. Stud                         | 7. Head Joist         | 13. Top Plate                  |
| 2. Door Header                  | 8. Plywood Subfloor   | 14. Rafter tail                |
| 3. Jack or Trimmer              | 9. Insect Barrier     | 15. Common Rafter              |
| 4. Bottom, Sole, or Lower Plate | 10. Bridging          | 16. Ridge Board or Ridge Piece |
| 5. Anchored Block or Sill Plate | 11. Rough Window Sill | 17. Ceiling Joist              |
| 6. Floor Joist                  | 12. Trimmer           |                                |



Building B:

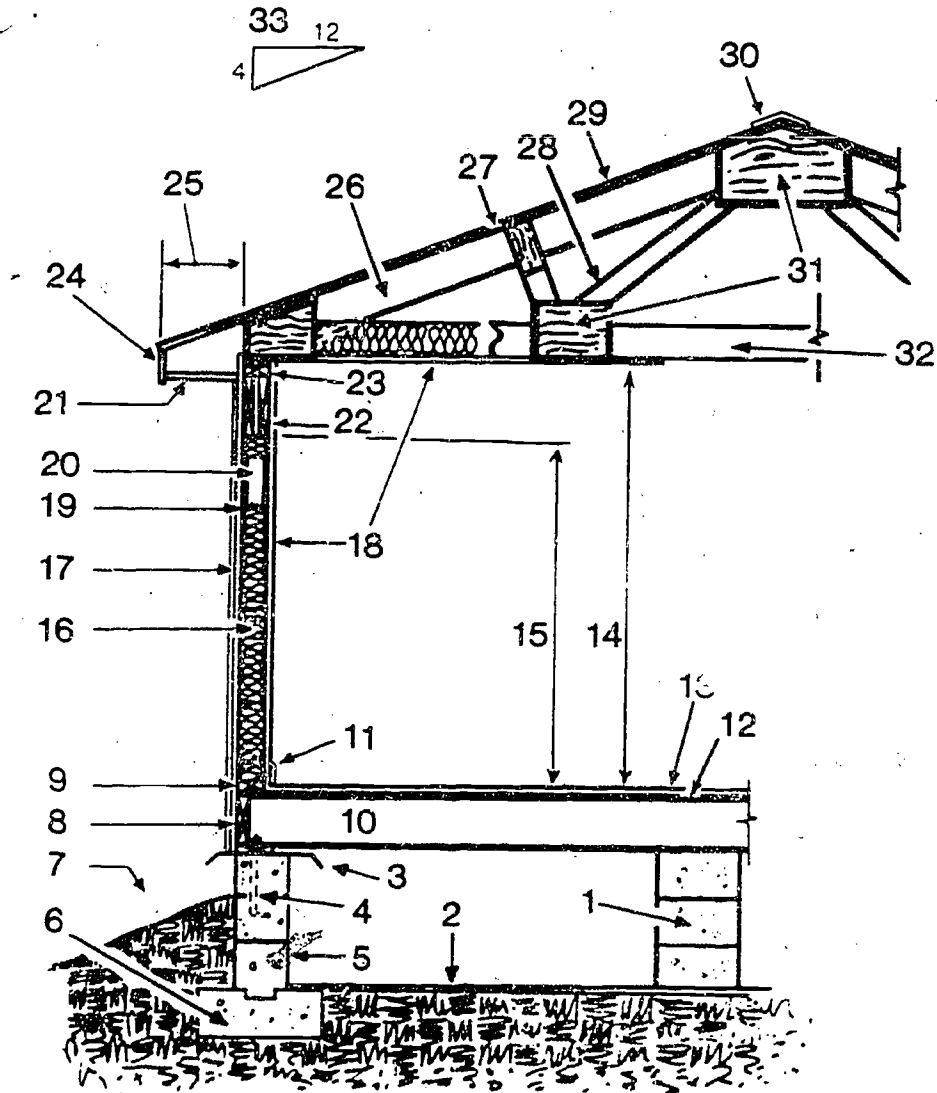

- |                                 |                        |                    |
|---------------------------------|------------------------|--------------------|
| 1. Masonry Pier                 | 12. Sub Floor          | 23. Upper Plate    |
| 2. Moisture Barrier             | 13. Resilient Flooring | 24. Facia          |
| 3. Insect Barrier               | 14. Room Height        | 25. Roof Overhang  |
| 4. Anchor Bolt                  | 15. Door-Window Line   | 26. Top Chord      |
| 5. Foundation                   | 16. Insulation         | 27. Sheathing      |
| 6. Footing                      | 17. Exterior Siding    | 28. Tension Web    |
| 7. Landscape Finish Grade       | 18. Interior Finish    | 29. Roof Covering  |
| 8. Header Joist                 | 19. Sheathing          | 30. Roof Ridge Cap |
| 9. Bottom, Sole, or Lower Plate | 20. Stud               | 31. Gussets        |
| 10. Stringer Joist              | 21. Soffit             | 32. Bottom Chord   |
| 11. Base Moldings               | 22. Vapor Barrier      | 33. Slope Triangle |

# PLYWOOD IN TRUSS CONSTRUCTION

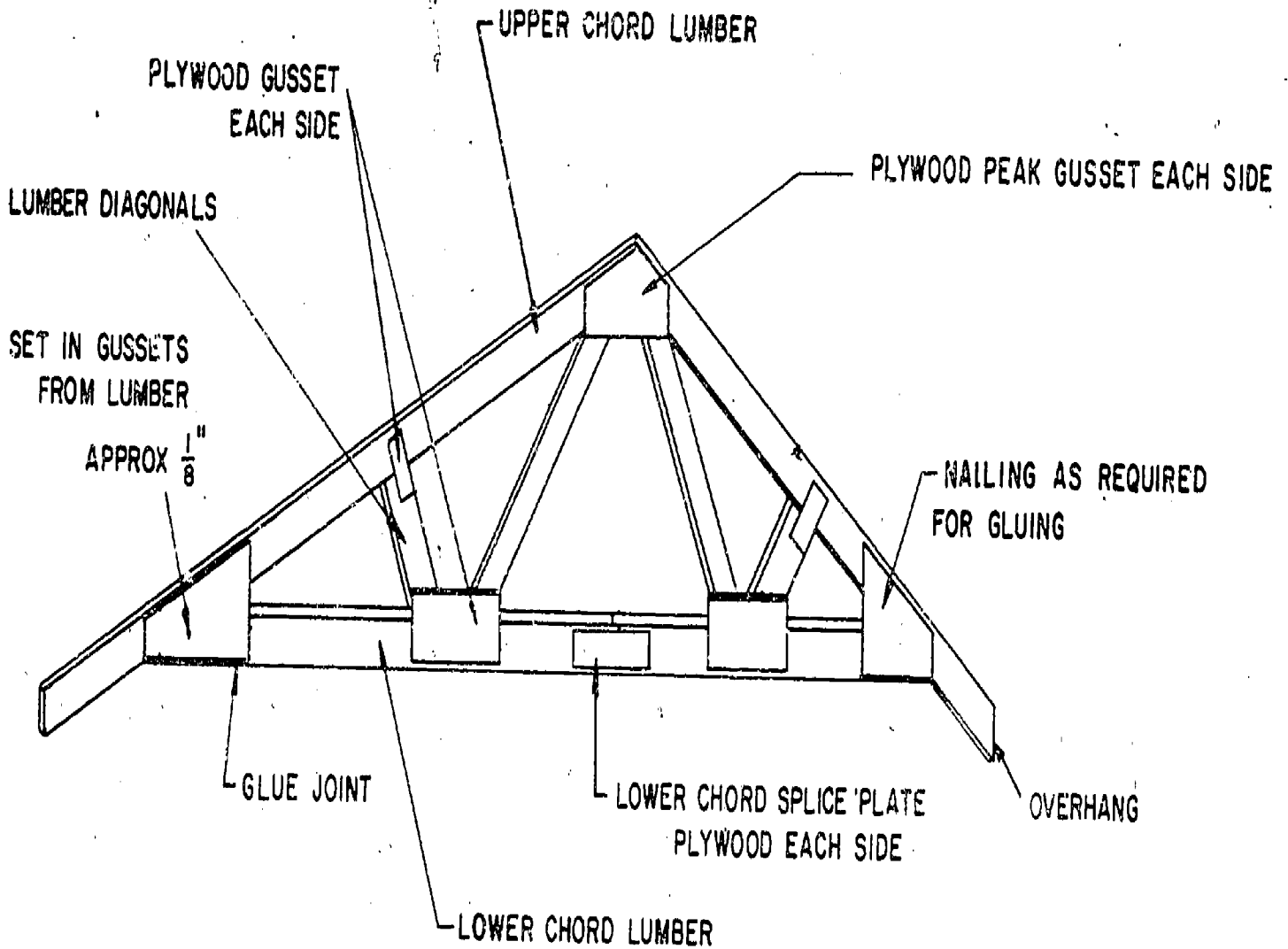

# PLYWOOD OVER TRUSS ROOF

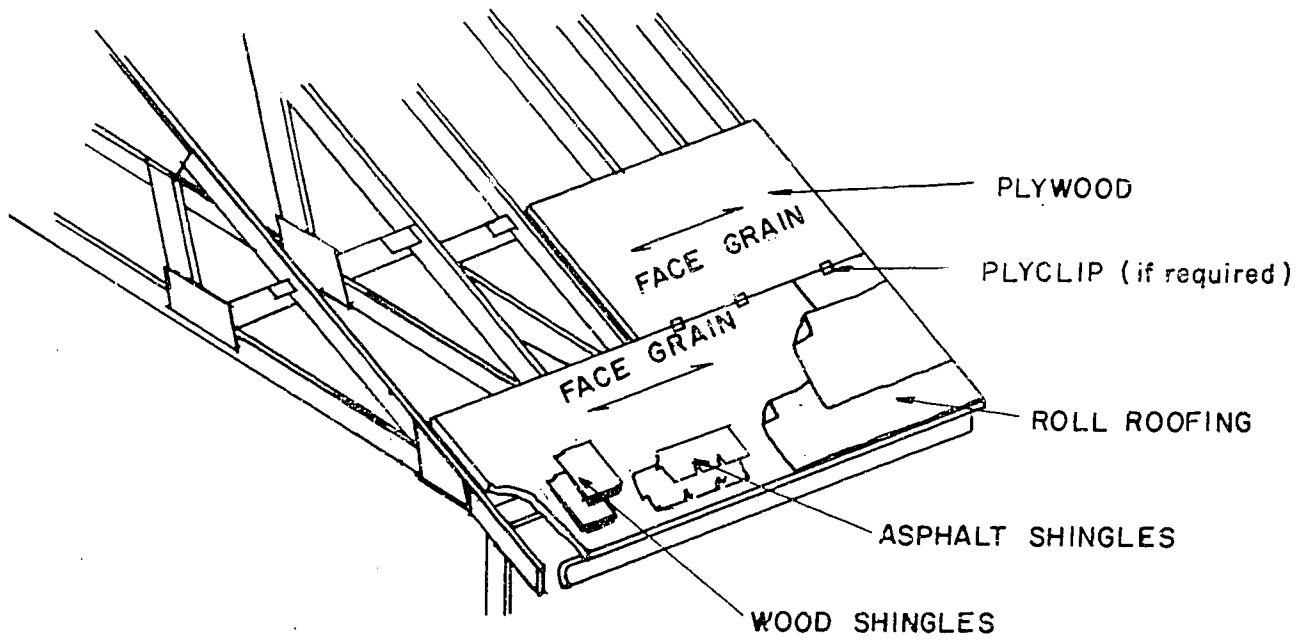

# PLYWOOD OVER RAFTERS

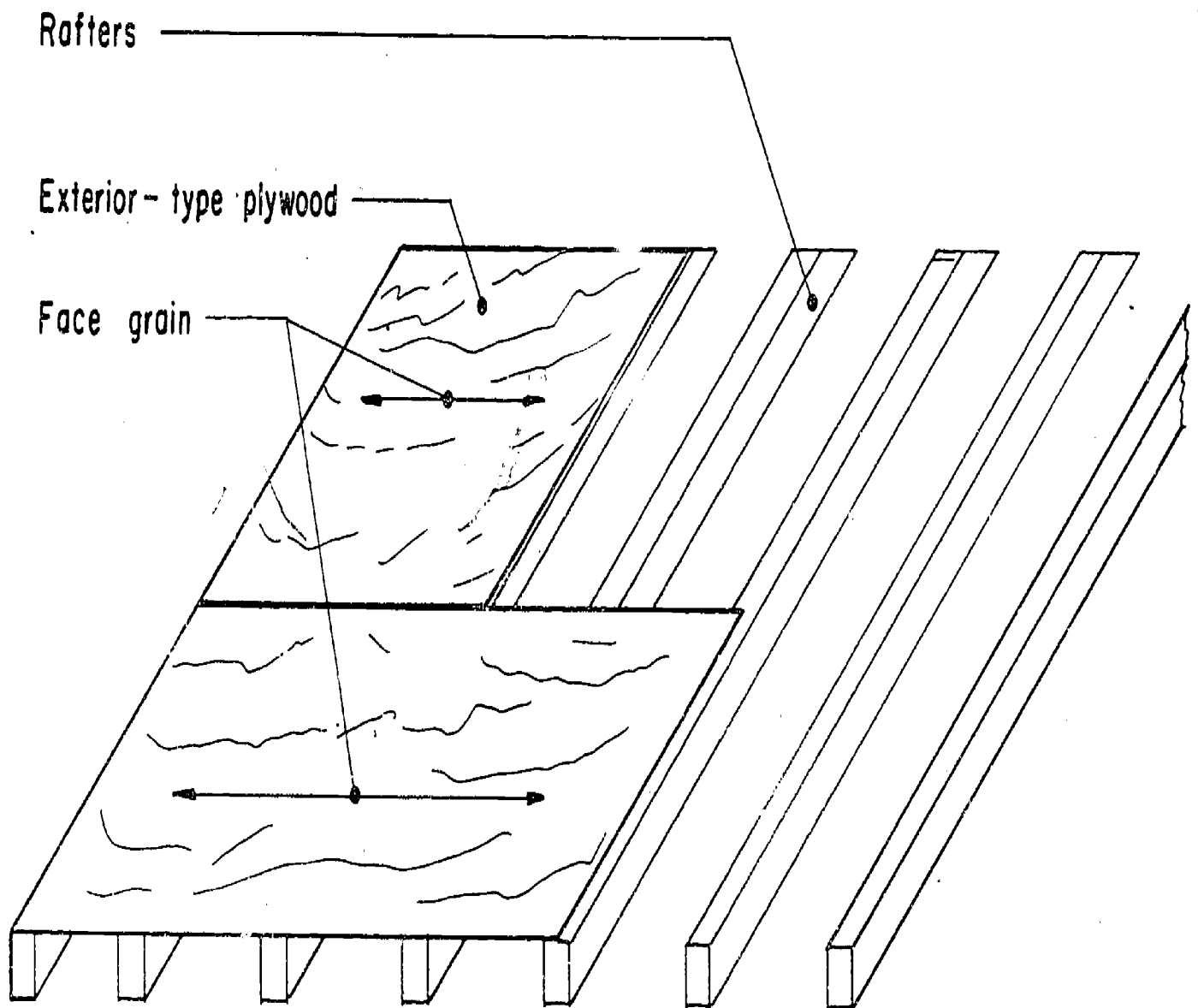

111-H-1-61

# SINGLE DOOR CONSTRUCTION

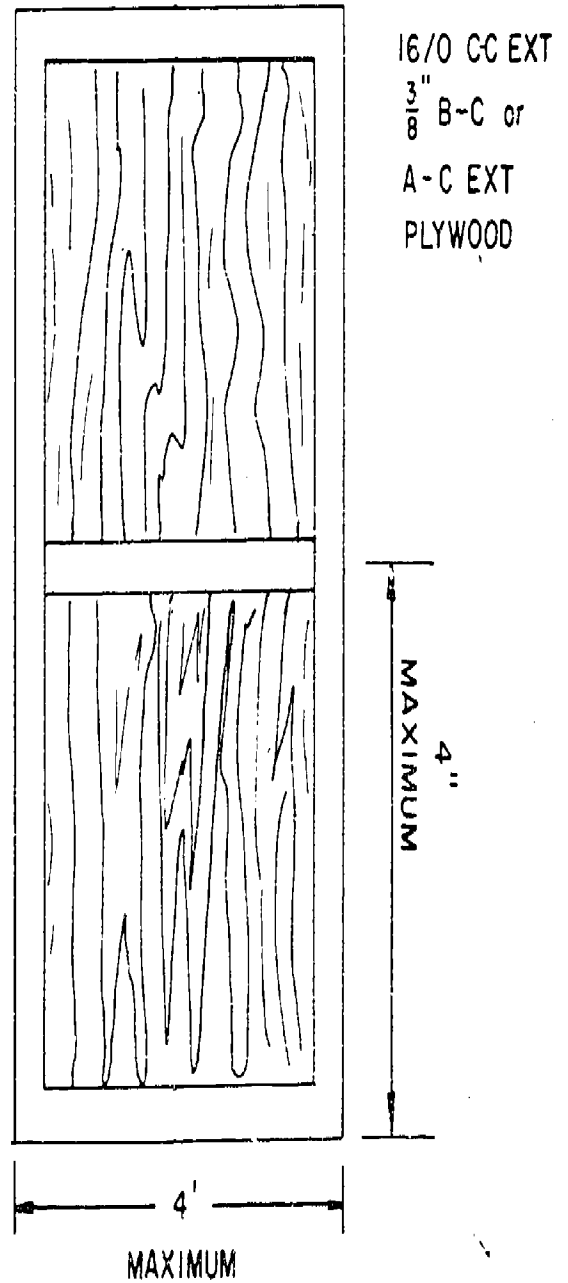
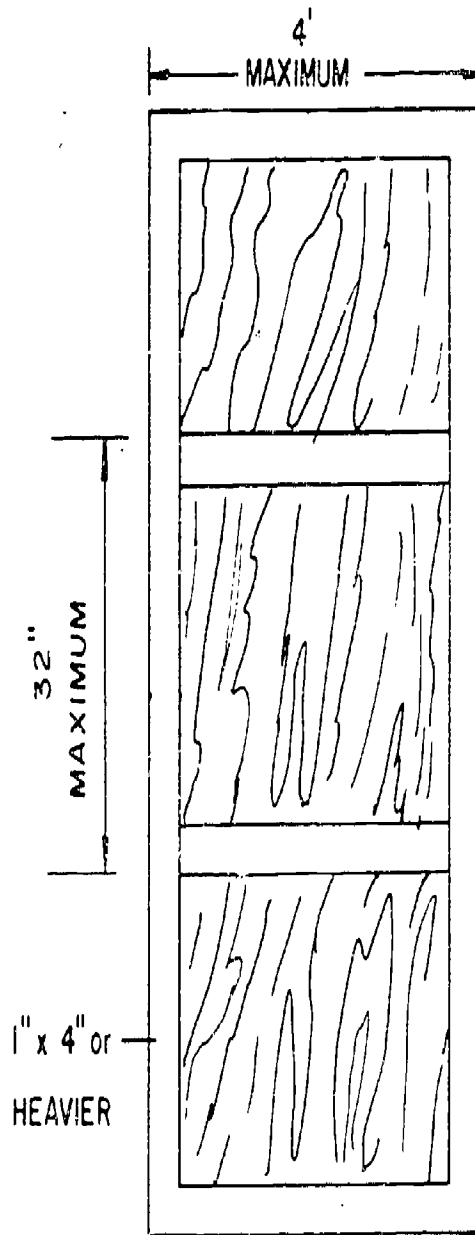

# NAILS COMMONLY USED



Common



Box



Roofing



Scaffold

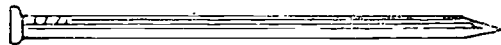

Siding

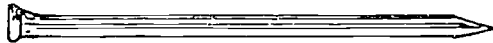

Casing

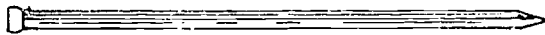

Finish

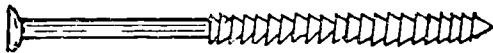

Pole Barn Nail

# IDENTIFICATION OF GRADE TRADE MARK Appearance Grade

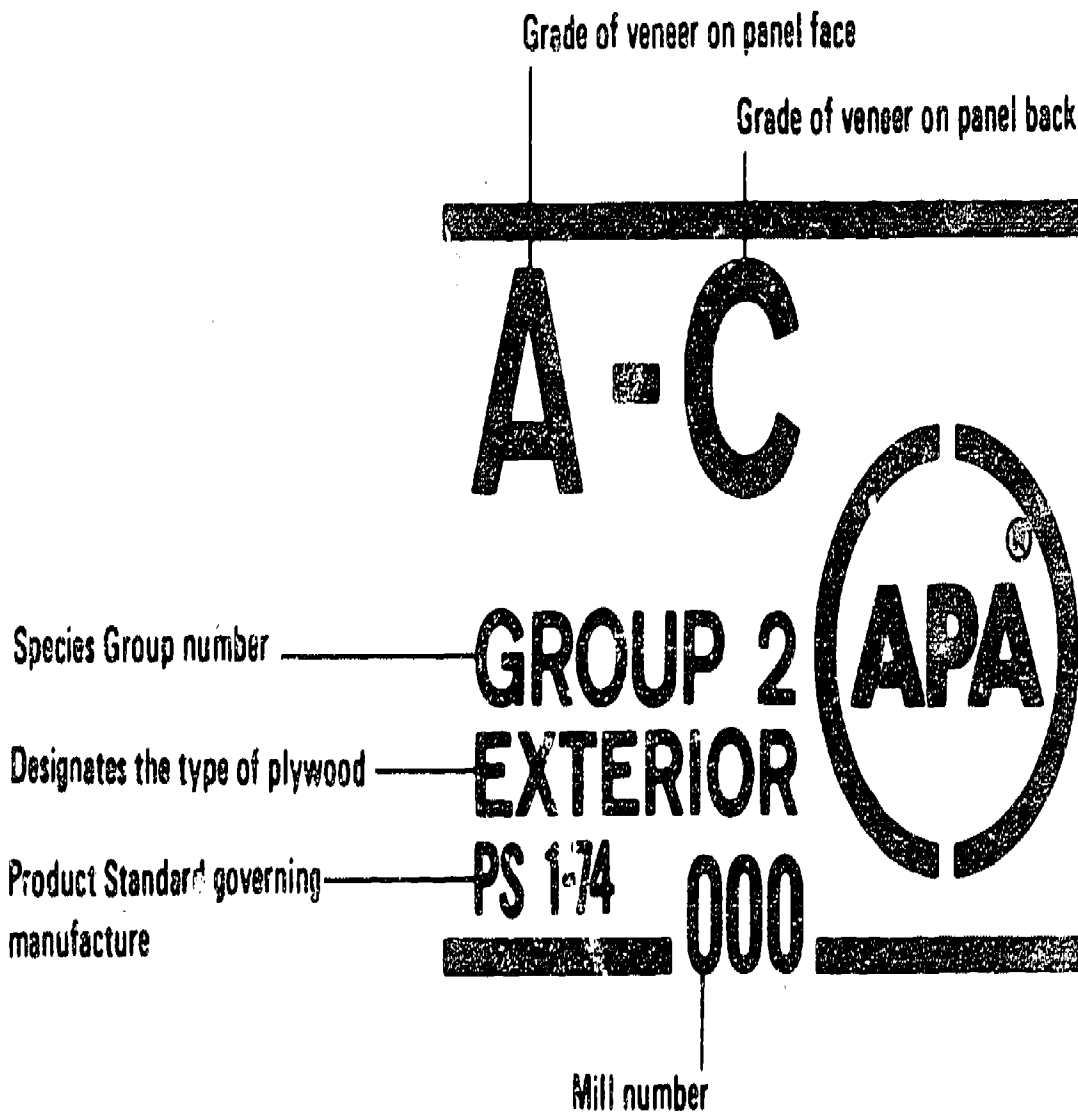

III-H-1-64

# IDENTIFICATION OF GRADE TRADE MARK

## Engineered Grade

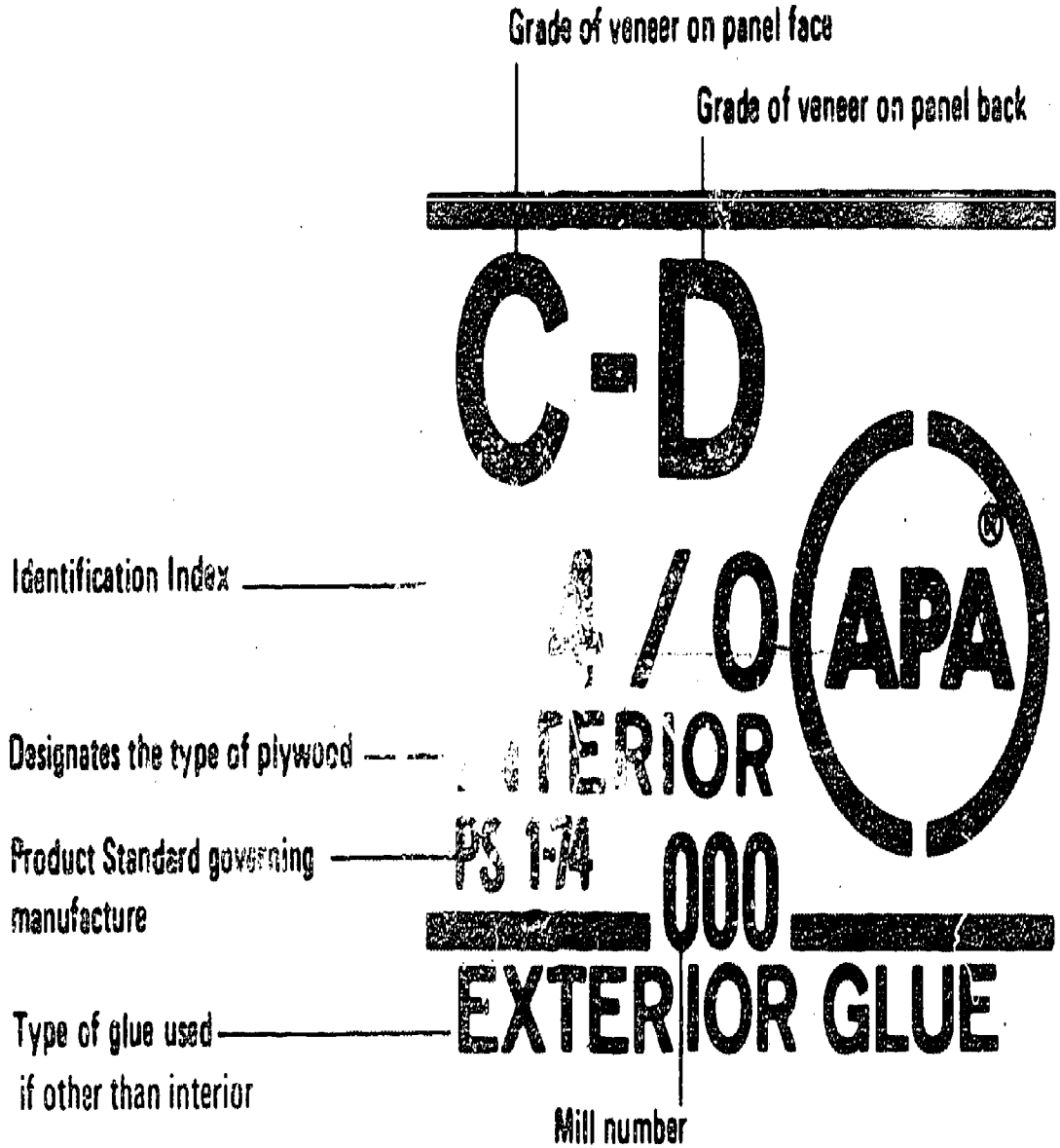

111-H-1-65



TYPICAL ENGINEERED GRADE TRADE MARK

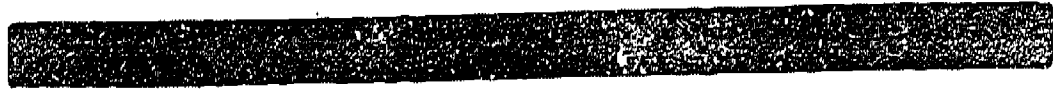

C=C

32/16

EXTERIOR

PS 1-74 000

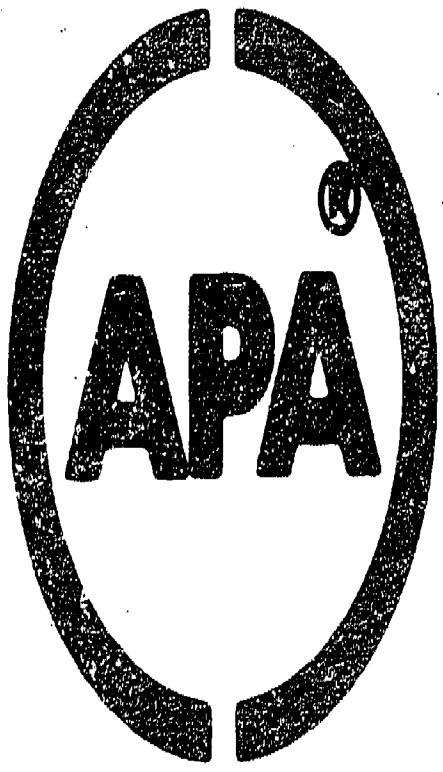

# ROOF SLOPE

Slope Triangle

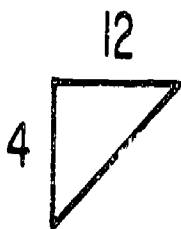

$$\text{Pitch} = \frac{\text{Rise}}{\text{Span}}$$

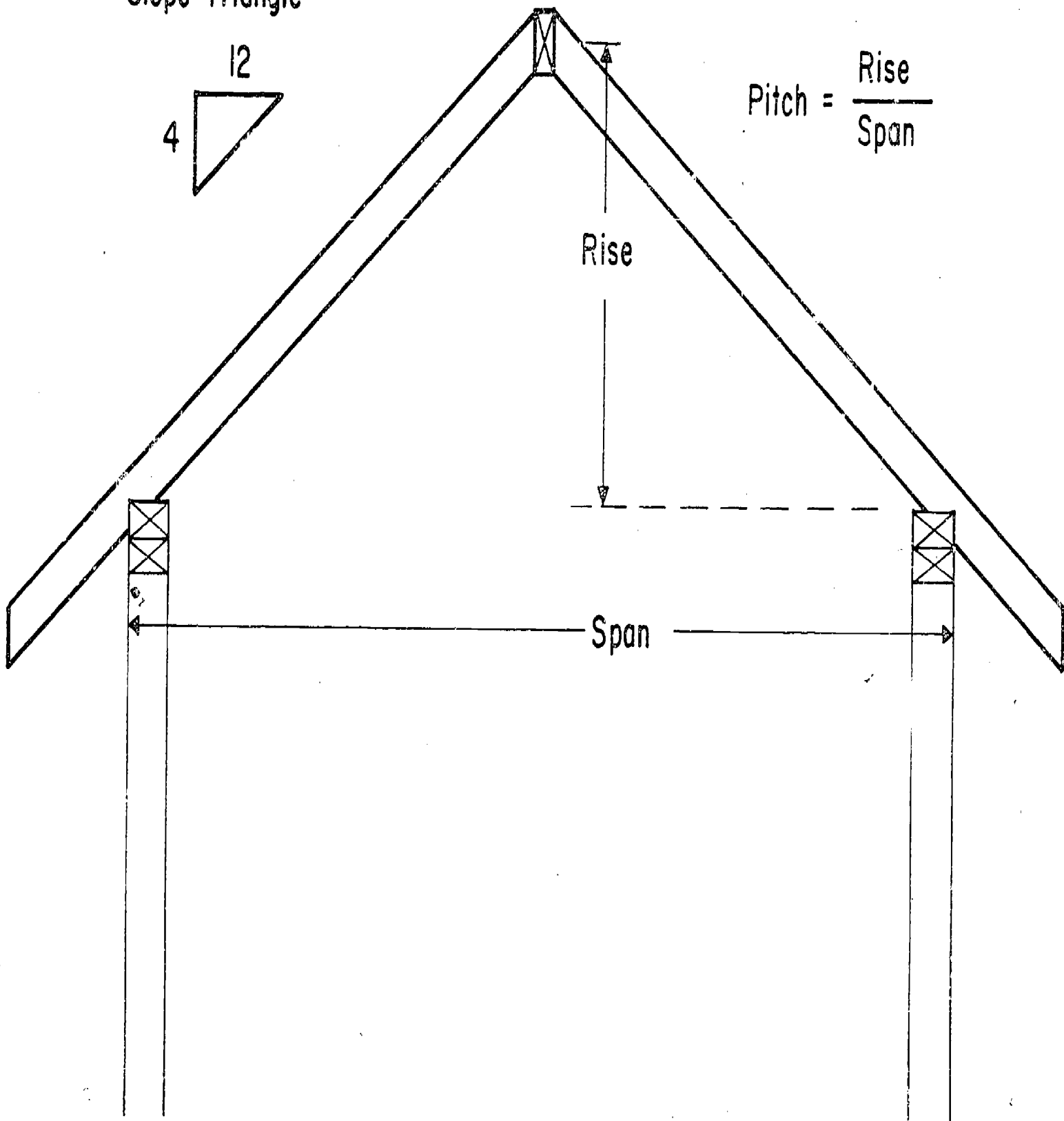

111-H-1-67

# RUN, SPAN & RISE GABLE ROOF

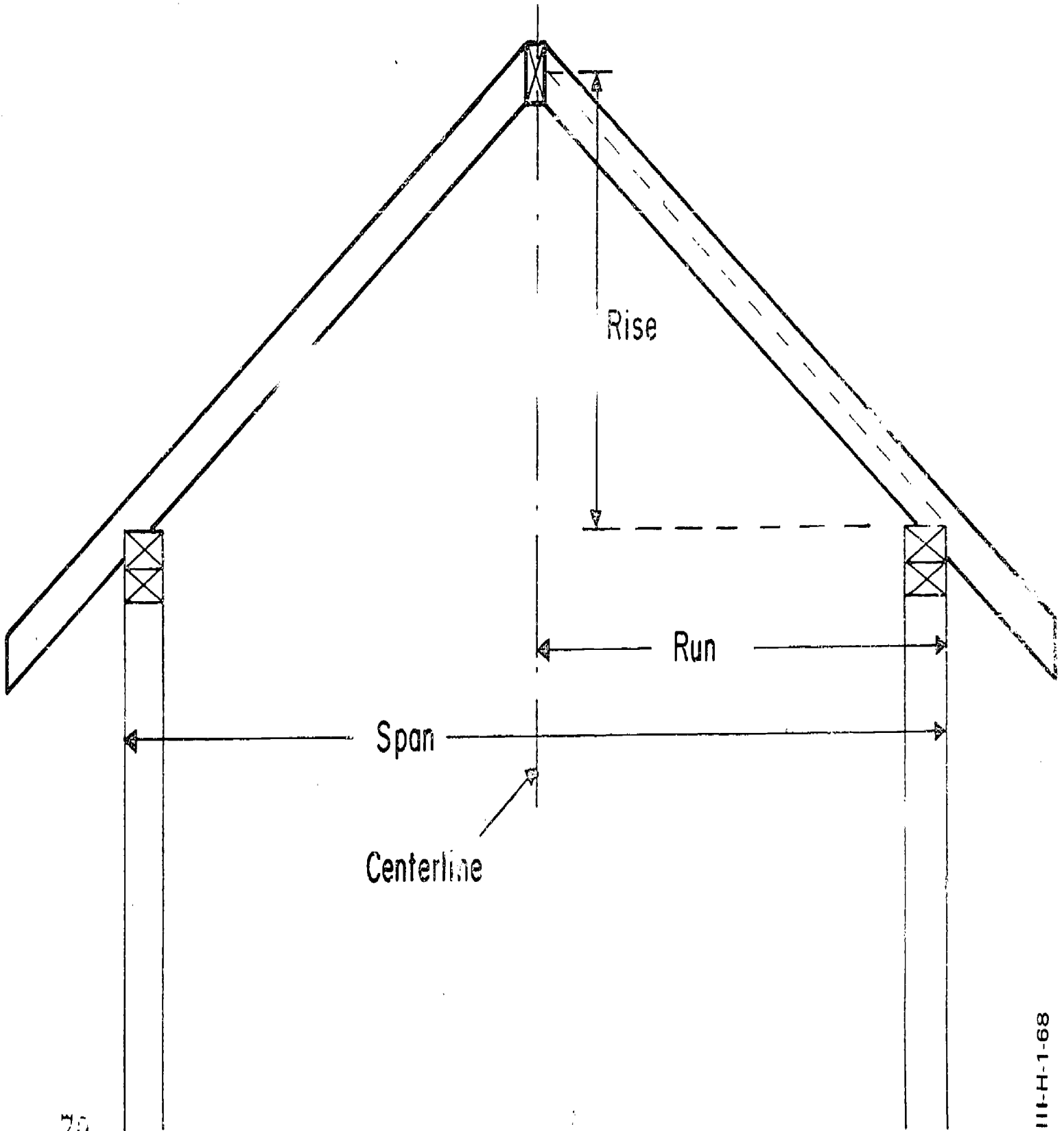

70

71

III-H-1-68

# CUTS FOR TRIM

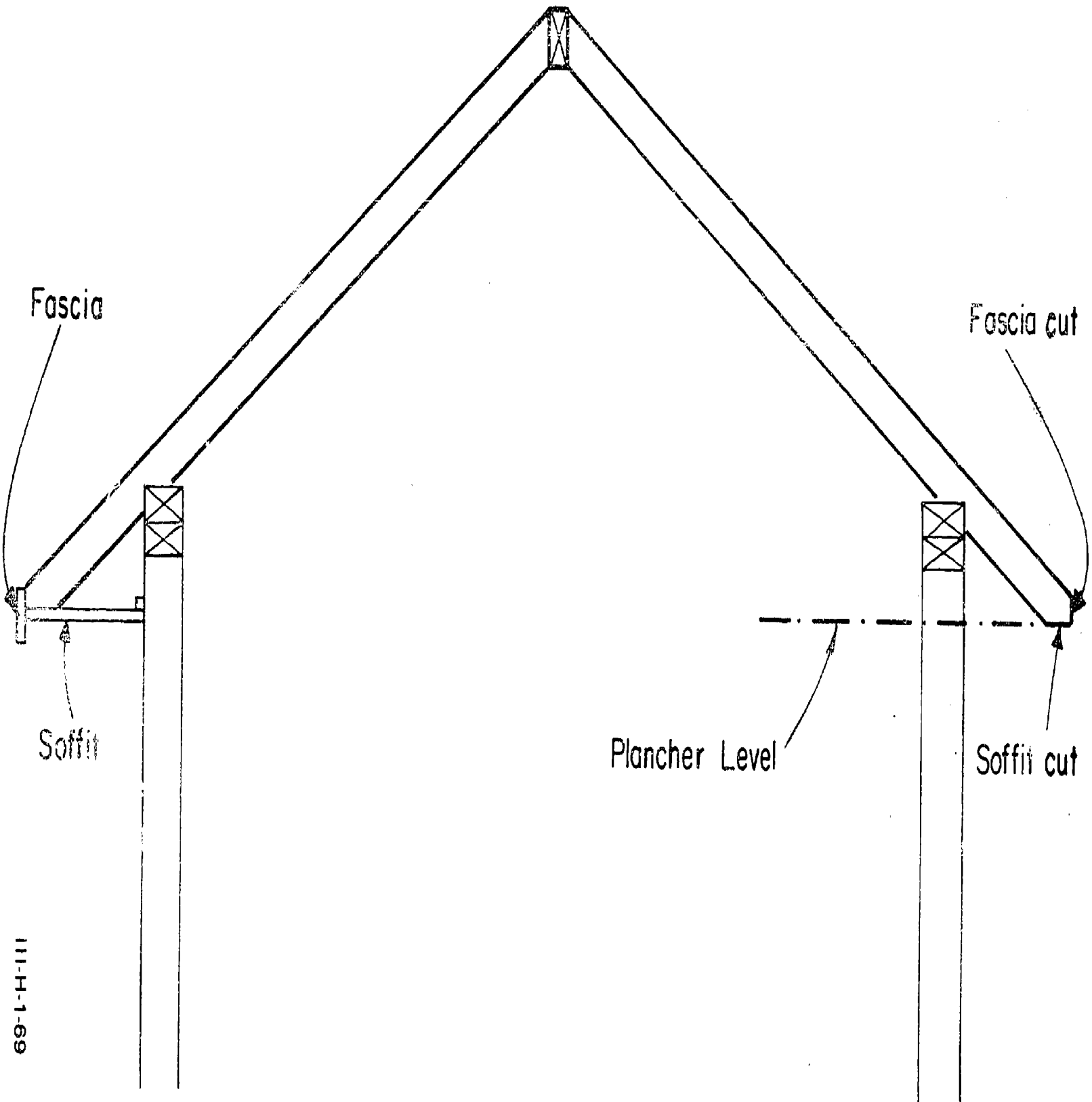

111-H-1-69

72

73

# Lumber Defects



Knot

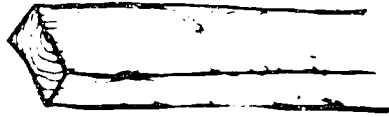

Cross grain



Shake



Check



Wane

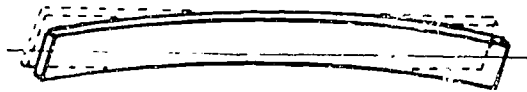

Bow

# Types of Milled Lumber



Center Match  
Sheathing



Paneling (V edge)

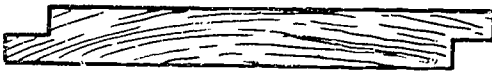

Shiplap



Drop Siding



Bevel Siding



Flooring

# Roof Frames

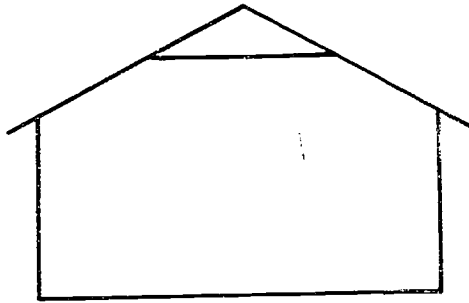

Simple Rafter

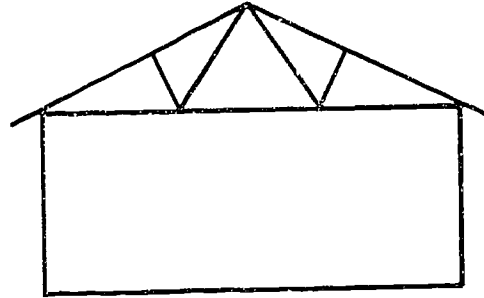

"W" Truss

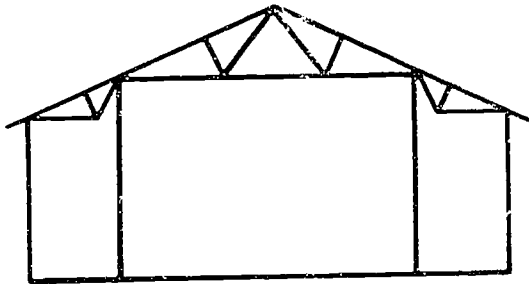

Multi-truss

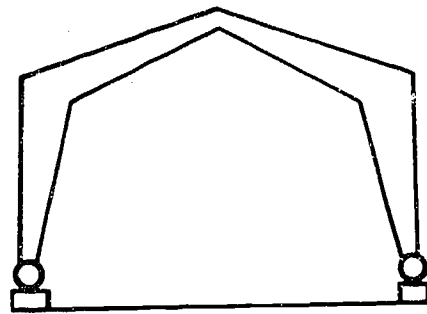

Two-hinge Rigid Frame

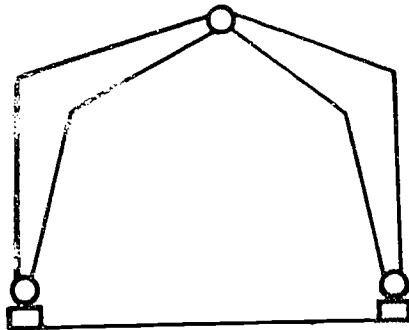

Three-hinge Rigid Frame

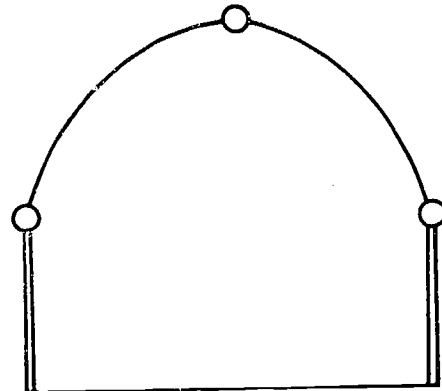

Three-hinge Arch

# Roof Shapes

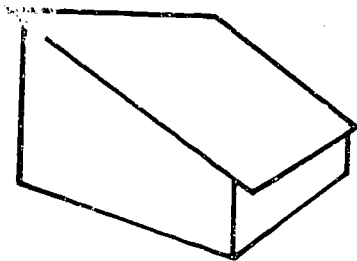

Shed

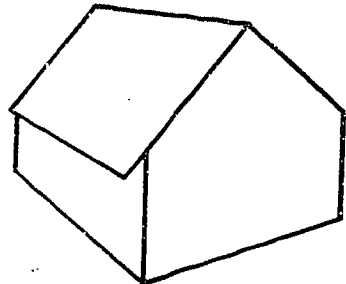

Gable

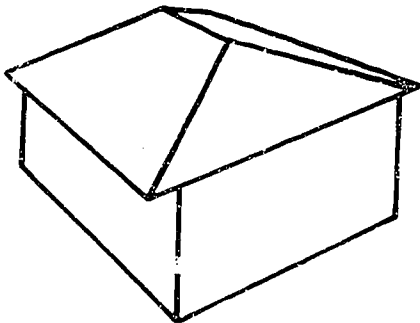

Hip

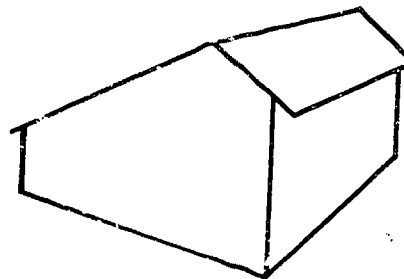

Offset Gable

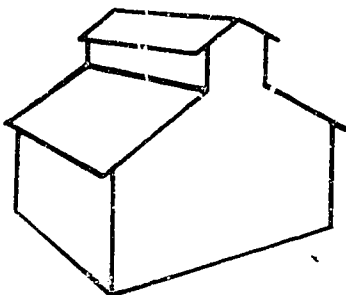

Monitor

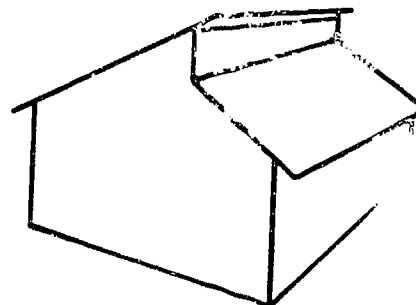

Semi-monitor



## Roof Shapes (cont.)

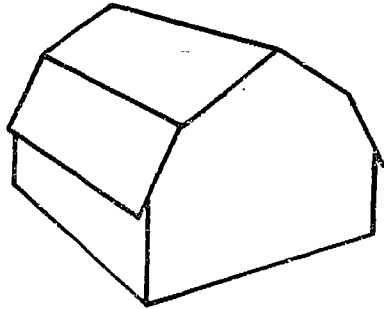

Gambrel

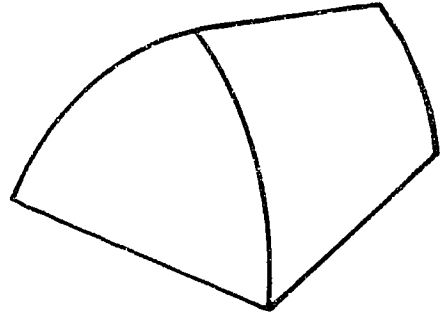

Arched

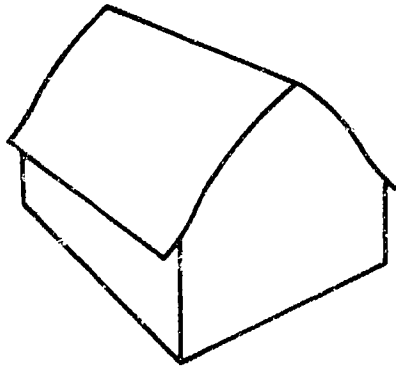

Arched

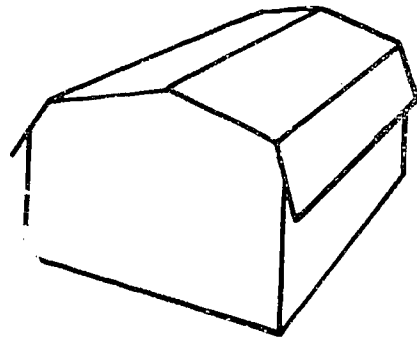

Mansard

# Parts of a Common Rafter

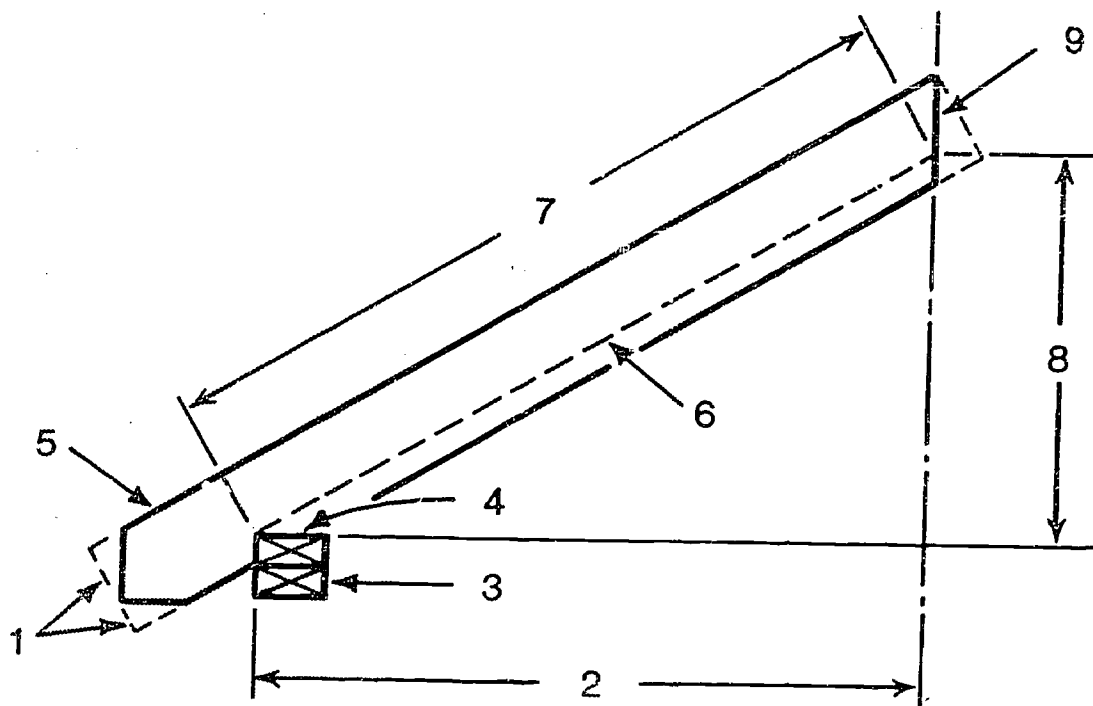

- 1 Tail Cuts and Lower Plumb Line
- 2 Run
- 3 Upper Plates
- 4 Seat Cut (Bird's Mouth)
- 5 Tail
- 6 Workline
- 7 Length
- 8 Rise
- 9 Ridge Cut (Upper Plumb Line)

# Types of Rafters

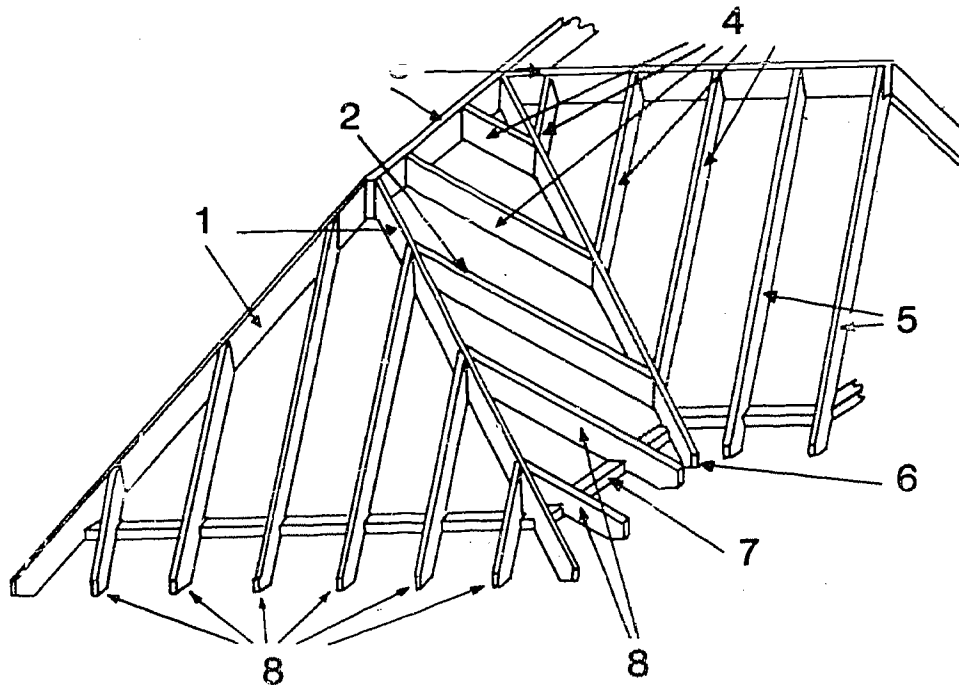

- 1 Hip Rafters
- 2 Cripple Rafters
- 3 Ridge Boards (Ridge Pieces)
- 4 Valley-Jack Rafters
- 5 Common Rafters
- 6 Valley Rafter
- 7 Top Plate
- 8 Hip-Jack Rafters

80

# Types of Trusses

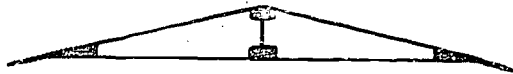

King Post

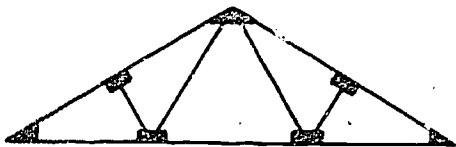

Fink or "W" Type

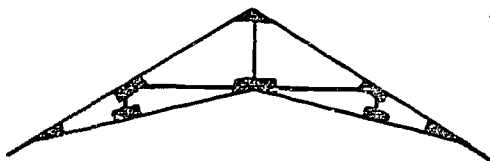

Scissors

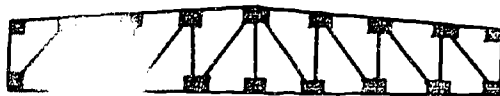

Flat Howe

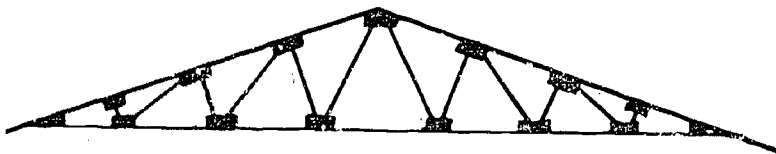

Belgian

# Insulation and Vapor Barriers

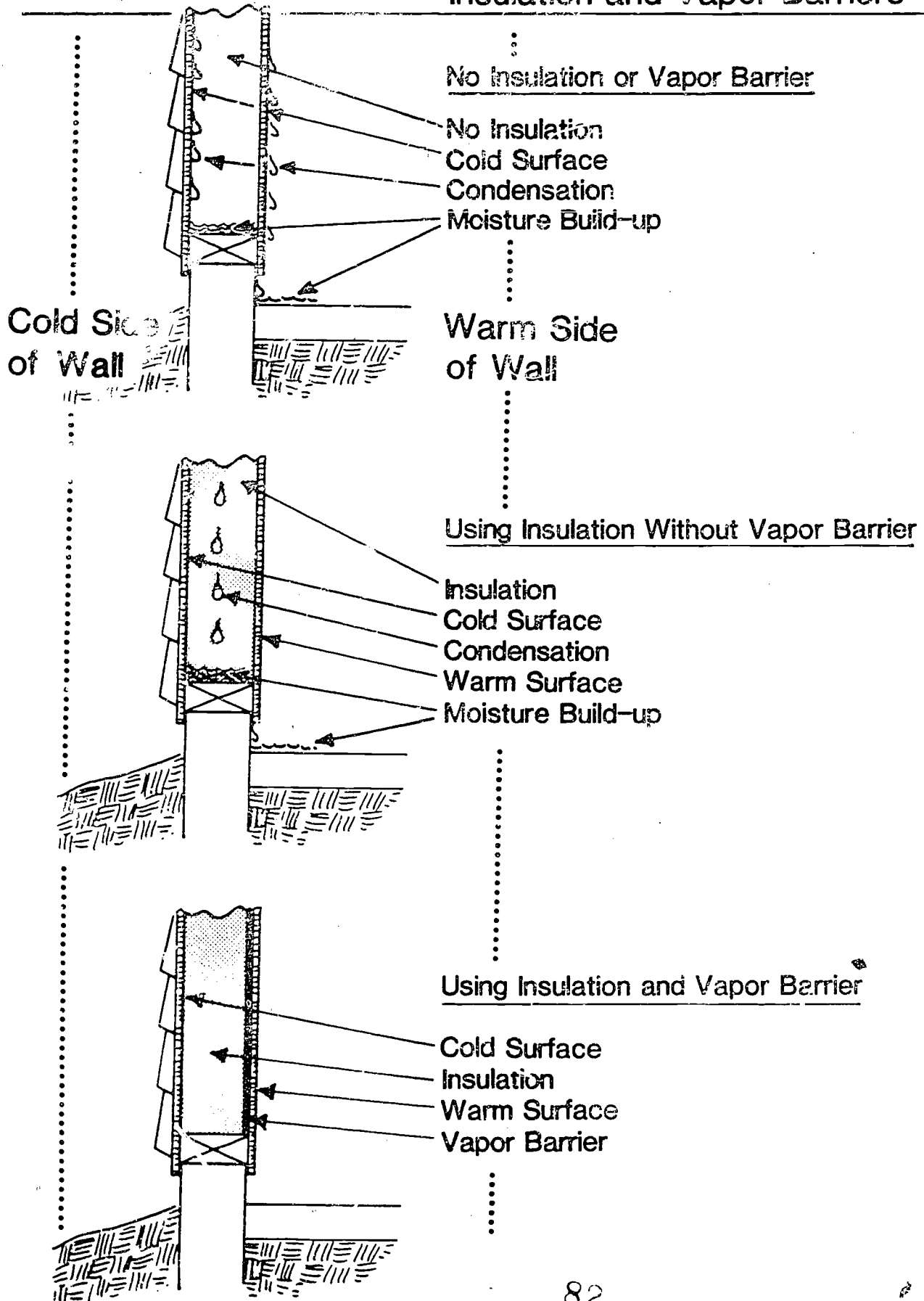

III-H-1-7-C

# Recommended Insulation for Illinois Winter Zones

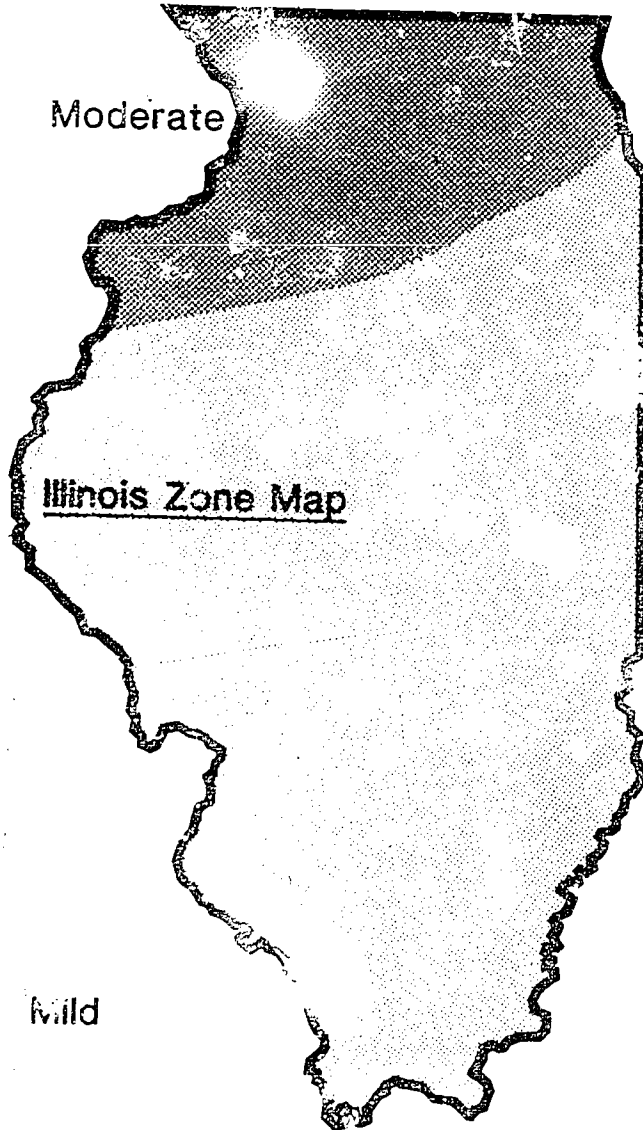

## Recommended Insulation

(Midwest Plan Service, Cooperative Extension Service)

Illinois Climate Zone	Resistance (R) <sup>1</sup>	
	Walls	Ceilings
Mild	9	12
Moderate	12	16

<sup>1</sup>) Total of resistances of insulation, lining and siding, surfaces, and air spaces.

## CONSTRUCTING AND MAINTAINING BUILDINGS

### TRANSPARENCY DISCUSSION GUIDE

#### I. PLYWOOD IN TRUSS CONSTRUCTION

Plywood gussets can be used in the fabrication of trusses that vary greatly in span, slope, and design. Gussets and splice plates are nailed and glued in place to provide extremely strong, durable joints.

#### II. PLYWOOD OVER TRUSS ROOF

Plywood makes excellent roof sheathing material when applied with the face grain across the supports. In this way the stiffness of the panel is fully utilized. Plyclips may be used as edge supports for abutting panel edges to prevent deflection from unusual concentrated loads that may cause roof damage.

Roll roofing, asphalt shingles or wood shingles may be applied over the plywood sheathing.

#### III. PLYWOOD OVER RAFTERS

Plywood is often used as roof sheathing material and it is applied with the face grain across the rafters.

#### IV. SINGLE DOOR CONSTRUCTION

Typical plywood doors are shown here. The plywood thickness required for a service door depends upon the following: size of door framing arrangements, wind load, method of hanging, and use. Experience has shown that 3/8-inch sanded or 5/16-inch C-C exterior plywood are the minimum requirements for plywood over framing for farm building doors. For maximum stiffness and strength, the face grain of the plywood should run across the intermediate framing members.

Doors covered with plywood do not need diagonal bracing because of the bracing action of the panel.

#### V. NAILS COMMONLY USED

Nonstaining nails are recommended for long service and freedom from rusting and staining. The zinc coating on galvanized nails protects against rusting. Nails are also made of metals or alloys which are not subject to corrosion. An aluminum nail is an example.

Common nails are for normal building construction conditions.

Box nails of the same penny size will have a smaller diameter than common nails. Since this smaller diameter has less tendency to split the lumber they are recommended for many uses. Although a box

nail has less holding power than a common nail, it should be remembered that lumber split by a common nail is practically useless.

Thin hardened, deformed shank nails have been developed to fasten framing to poles in pole buildings. These nails are made in sizes from 3d to 30d with the 4-inch, 5-inch, and 6-inch lengths most commonly available.

#### VI. IDENTIFICATION OF GRADE TRADE MARK

##### Appearance Grade

The grade trade mark for appearance grade plywood will look like this. The grades of the face and back panels are shown by the large letters. The species group number is given. The type of plywood, Exterior or Interior is shown as well as the mill number. The product standard under which the plywood was manufactured is shown in the lower corner.

#### VII. IDENTIFICATION OF GRADE TRADE MARK

##### Engineer Grade

The grade trade mark for engineered grade plywood shows the identification index is a two-element number separated by a slash. The number on the left indicates the maximum recommended spacing of supports (roof framing) in inches when the panel is used for roof decking. The number on the right indicates the recommended spacing in inches when the panel is used for subflooring. This mark indicates this panel may be used for roof decking over supports 24 inches on center but would not be used for subflooring at all.

#### VIII. TYPICAL ENGINEERED GRADE TRADE MARK

The grade trade mark for engineered grade of plywood is similar to transparency No. 29. Can you tell what the C-C, 32/16, and Exterior mean?

#### IX. ROOF SLOPE

The roof slope is usually given on a plan or drawing as a small triangle called the slope triangle. This usually gives the inches of rise per foot of run. In the illustration shown here the rafters rise 4 inches per foot of run. This is sometimes expressed as a 4-12 slope. Formerly it was a common practice to define pitch as rise over span. It was expressed as a fraction. In this example it would be 4 over 24 or one-sixth pitch ( $1/6$ ). A 4-12 slope is actually  $1/6$  pitch, using the older system.



## X. RUN, SPAN AND RISE

The run is a horizontal line under the rafter that extends from the outer edge of the building to a plumb line from the center of the ridge piece. The total run of a rafter is 1/2 the span of the building.

The span is the distance from one outside wall line to the other outside wall line. The span is the width of the building and it is 2 times the length of the run.

The rise is a length of a perpendicular line from the marking line at the ridge piece to a line horizontal with the top of the plate. The rate of rise is determined from the slope triangle.

## XI. CUTS FOR TRIM

The vertical cut on the end of the rafter is called the fascia cut. The fascia or trim board is nailed to the rafter along this vertical cut. If the cornice is to be enclosed, the horizontal cut on the rafter is called a soffit cut. The imaginary horizontal line is called the plancher level and sometimes the board that is used to enclose the cornice is called the plancher or the soffit.

## XII. LUMBER DEFECTS

Discuss the common quality factors which influence the use and grade of lumber. Point out the following factors:

- a. Knot - Usually a branch of a tree. They may be loose or tight. They can influence or reduce the strength and appearance of the lumber.
- b. Cross-grain - These boards are generally not strong. These occur when the saw-mill uses a crooked log.
- c. Shake - Occurs when lumber cracks along a growth ring. Reduces appearance and usefulness of board.
- d. Check - A crack part way through the wood that occurs across the growth rings.
- e. Wane - Absence of wood along the edge of a board. These may have exposed bark on the edge.
- f. Bow - May not be a true defect, but these conditions make lumber hard to work. These defects can also include twists, crooks, and cups in the lumber.

## XIII. TYPES OF MILLED LUMBER

Point out that these are examples of dressed lumber which has been worked on one or more edges. These boards are applied either vertically or horizontally as siding or flooring. Drop siding is

installed similar to lap siding except for board spacing and nailing. The minimum lap for bevel siding should not be less than one inch. Siding should be square cut to provide a good butt-joint. Fresh-cut ends of siding should be dipped into a water-repellent preservative before they are nailed into place.

#### XIV. ROOF FRAMES

Identify common types of roof frames found in the local area. Discuss some of the major factors one must consider when selecting a certain roof frame for a building structure. Point out the following considerations:

- a. Type of framing - Rigid frame, pole frame or other type.
- b. Length of span.
- c. Vertical clearance of building.
- d. Load factor from snow, wind, frame.

#### XV. ROOF SHAPES

The style and purpose for which a building was constructed often influences the design and type of a roof structure. The slope of the roof is influenced by the type of roofing material used, wind velocity, snow fall, rain fall, and structural design of the building.

- a. Shed - Low pitched or almost flat roof. Roofs of this type may require longer and more closely spaced rafters because they support both roof and ceiling loads. This type of roof is simplest to construct when the span does not exceed 18 to 20 feet.
- b. Gable - The simplest type where both rafters and ceiling joists are needed. All rafters are cut to the same length and pattern. This is the most common roof design used on houses and is in the middle range on cost construction.
- c. Hip - Center rafters are fastened to a ridge board. These are more expensive to construct and more complicated to erect. Often used for their appearance.
- d. Offset Gable - These are also referred to as combination roofs. These are used on buildings where one side is to be left open. It could be the high side or low side which is open, depending on the use of the shed.
- e. Monitor - These roofs are used to increase the amount of natural light which enters the building.  
and  
Semi-monitor They are expensive to construct due to framing requirements.

- f. Gambrel - These roofs became popular around the first part of this century because of their large storage space for grain and hay. Today, this style of roof is not as popular on farms due to changes in grain storage. Also, this type of roof is expensive to construct, it does not wear evenly, and it has a higher wind resistance than other styles.
- h. Mansard - This design is popular on sheds which are used primarily for machinery storage. The low pitch provides for optimum clearance. Many of these are pole frame with metal siding and roofing.

#### XVI. PARTS OF A COMMON RAFTER and TYPES OF RAFTERS

Discuss the parts of a rafter and the different types of rafters needed for various roof designs. Point out the following on types of rafters:

- a. A common rafter (5) extends from the plate (7) to the ridge board (3) at a right angle.
- b. A cripple rafter (2) connects to the hip (1) and valley (6) rafters.
- c. A jack (4 and 8) are common rafters that intersect a hip or valley rafter before they reach either the ridge board or plate.

Have students practice marking the cuts for a common rafter. Have students cut a common rafter to a given pitch and length.

#### XVII. TYPES OF TRUSSES

The trussed rafter is an assembly of members fastened together to form a rigid framework of connecting triangular shapes. This rigid frame is capable of supporting heavy loads over long spans without intermediate support. The truss rafter saves material, can be assembled and erected quickly, and is cheaper than cutting and using common rafter techniques.

King-post, W-type, and sissors trusses are most commonly used for houses and can be used easily on spans ranging from 20 to 60 feet.

The W-type truss is very popular and is most extensively used in light wood trusses.

The King-post truss is the simplest truss to construct. It has less strength than the W-type truss and must only be used on short to medium spans.

The Sissors type truss can be used where a sloping ceiling is desired. It is somewhat more complicated to construct than the W-type truss, but it provides for greater vertical clearance.

The Flat Howe can be used on spans greater than 50 to 60 feet. The roof is relatively flat and many times this truss is fabricated using metal members.

The Belgian truss can be used on spans greater than 50 to 60 feet. The roof is sloping or pitched.

When selecting a type of truss rafter, some factors which need to be considered are:

- |                        |   |
|------------------------|---|
| a. Width of building.  | e. Type of roofing material to be used. |
| b. Pitch of roof.      | f. Desired ceiling clearance.           |
| c. Expect snow load    | g. Roof design or style.                |
| d. Expected wind load. |   |

XVIII. INSULATION AND VAPOR BARRIERS AND RECOMMENDED INSULATION FOR ILLINOIS WINTER ZONES

- A. Use these transparencies to supplement the information sheet on insulation.
- B. Point out the importance of having good insulation and a vapor barrier around doors and windows.
- C. Point out that the vapor barrier is located on the warm side of the building wall and below the insulation in an attic space.
- D. Have students examine various materials used for insulation and vapor barriers.

Teacher's Key  
Sample Test Questions

Constructing and Maintaining Buildings

TRUE (+) – FALSE (0)

- + 1. Every species of lumber is characterized by its own set of properties.
- + 2. The lumber you select for a job depends in part on what characteristics (hardness, decay resistance, strength, weight, etc.) are important for the particular use.
- 0 3. Spring wood is the result of small, thick-walled, dark colored cells produced in the spring.
- + 4. The key to sensible, economical construction is to "use the lowest quality of lumber suitable for the purpose."
- 0 5. Wood grows as a result of an increase in the size of individual cells.
- + 6. Older sapwood becomes inactive, usually darkens, and changes into matured wood known as heartwood.
- 0 7. While there is no difference in strength and weight, sapwood is more durable than heartwood when exposed to the weather.
- 0 8. Moisture and food are carried across and up and down the tree trunk by medullary wood rays.
- + 9. When trees with large sap-conducting cells are cut into lumber, the splitting of these large cells produces porous open-grained wood.
- + 10. "Worked lumber" is wood that has been shaped, matched, or patterned, such as molding, flooring, and siding.

MULTIPLE CHOICE (Make appropriate choice of A, B, C, D, or E)

- D 1. Hardwood grading is based on:
- A. Length and width of the board
  - B. Percent of usable lumber in each board
  - C. Strength
  - D. A and B
  - E. A, B, and C
- C 2. Which one of the following is **not** a classification category for softwood grading?
- A. Yard lumber
  - B. Factory or shop lumber
  - C. Clear face finish lumber
  - D. Structural lumber
- B 3. When building specifications call for stress rated lumber, such as in trusses, use:
- A. Dimension lumber
  - B. Structural lumber
  - C. Only special order lumber
  - D. Factory lumber
  - E. None of the above

- D 4. In which of the following classes is appearance an important factor in grading?
- Finish lumber
  - Common boards
  - Dimension lumber
  - A and B
  - A, B, and C
- A 5. Lumber for general construction purposes is classified as
- Yard lumber
  - Shop lumber
  - Structural lumber
  - A and B
  - A, B, and C
6. Which of the following is not a grade for dimension lumber:
- Superior
  - Construction
  - Standard
  - Utility
  - Economy
- D 7. In plywood grading:
- Only the exposed surface is graded
  - All layers or plies are graded and averaged for the final grade
  - All the layers must be the same grade
  - The two outer layers are graded and referred to
  - None of the above
- B 8. "C and better" and "D" are the grades most lumber yards handle of:
- Dimension lumber
  - Select or finish lumber
  - Common boards
  - Structural lumber
  - Plywood
- E 9. "A-D ext.," "A-C int.," and "CDX" are the grades most lumber yards carry of:
- Dimension lumber
  - Select or finish lumber
  - Common boards
  - Structural lumber
  - Plywood
- E 10. Some lumber is bought and sold by the board foot. The formula for figuring board feet is:
- $\frac{L'' \times W'' \times T''}{144}$
  - $\frac{L' \times W' \times T'}{12}$
  - $\frac{L' \times W'' \times T''}{12}$
  - A and B
  - A and C

MATCHING (Match the correct terms with the quantities listed.)

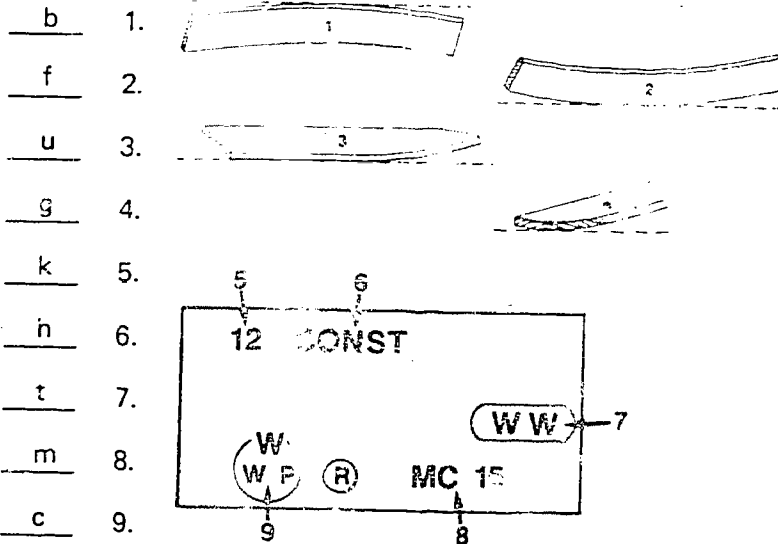

- a. Bending strength
- b. Bow
- c. Certification mark
- d. Check
- e. Compression strength
- f. Crook
- g. Cup
- h. Grade
- i. Hardness
- j. Knot
- k. Mill identification
- l. Milling imperfections
- m. Moisture content
- n. Nail holding power
- o. Shake
- p. Split
- q. Stiffness
- r. Strength
- s. Swelling & shrinking
- t. Tree species
- u. Twist
- v. Toughness
- w. Wane
- x. Warp
- y. Weight

- b 1.
- f 2.
- u 3.
- g 4.
- k 5.
- h 6.
- t 7.
- m 8.
- c 9.
- x 10. Term used to describe any of the distortions pictured in 1--4.
- j 11. Is a part of a branch which has become incorporated into the body of a tree.
- 12. Separations along the grain or across the growth rings:
  - p a. Extending all the way through the lumber.
  - d b. Extending part way through the lumber.
- a 13. Ability of lumber to be bowed or bent without breaking.
- l 14. Loose, raised, or torn grain, planing skips, and machine burns.
- w 15. Presence of bark or absence of wood along the edge of a board forming a bevel.
- v 16. Ability of wood to withstand sudden shocks, jars, or blows without breaking -- if failure does occur, wood with this property tends to crack instead of splinter.
- e 17. Ability of a piece of lumber to resist being mashed or squeezed together by weight applied against its ends.
- q 18. Ability of wood to resist bending under load.
- i 19. Property that causes wood to be solid, resist dents, nicks or scratches, and difficult to cut or nail.
- y 20. When dry woods are compared, this property is easy to determine and is a good indicator of relative strength.

COMPLETION (Write appropriate information or words to complete statements.)

1. Wood is the hard substance under the bark of trees which, when cut into boards, is called lumber. It consists of long narrow tubes or cells, called fibers. Tiny strands of cellulose make up the walls of the cells. The weight and strength depends largely on the thickness of the cell walls. The shape, size, and arrangement of the fibers account for many of the differences in woods.
2. Wood growth occurs in a layer of cells under the bark called the cambium.
3. Xylem is cells produced to the inside of the cambium, forms new wood, and carries water to the leaves.
4. Phloem is produced to the outside of the cambium; forms the inner bark, and carries food to all parts of the plant.
5. The change from light colored "springwood" to the darker colored "summerwood" results in what is called annual growth rings.
6. Softwood is lumber cut from coniferous (cone bearing) evergreen trees with needlelike leaves, and hardwood is lumber cut from broad-leaved deciduous trees.
7. Lumber that contains 20% or more moisture is referred to as green lumber.
8. Nominal or rough lumber is lumber as it comes unplanned from the saw. After the lumber is planed, we refer to its dimensions as dressed or milled or actual.
9. Defects or imperfections are irregularities occurring in or on the wood that reduce the strength, durability, and/or usefulness of the lumber. An imperfection that affects only the appearance of the wood is called a blemish.
10. Lumber can be seasoned in the open air or placed in a large oven called a kiln where temperature and humidity are carefully controlled.



## ESSAY QUESTIONS

1. Explain the two sawing techniques for cutting lumber from trees and then describe the two ways it can be seasoned:  
(refer to VAS Unit 3055)

2. How should lumber be stored if it must be stored outside?  
(refer to VAS Unit 3055)

# PARTS OF ROOF

11-1-92

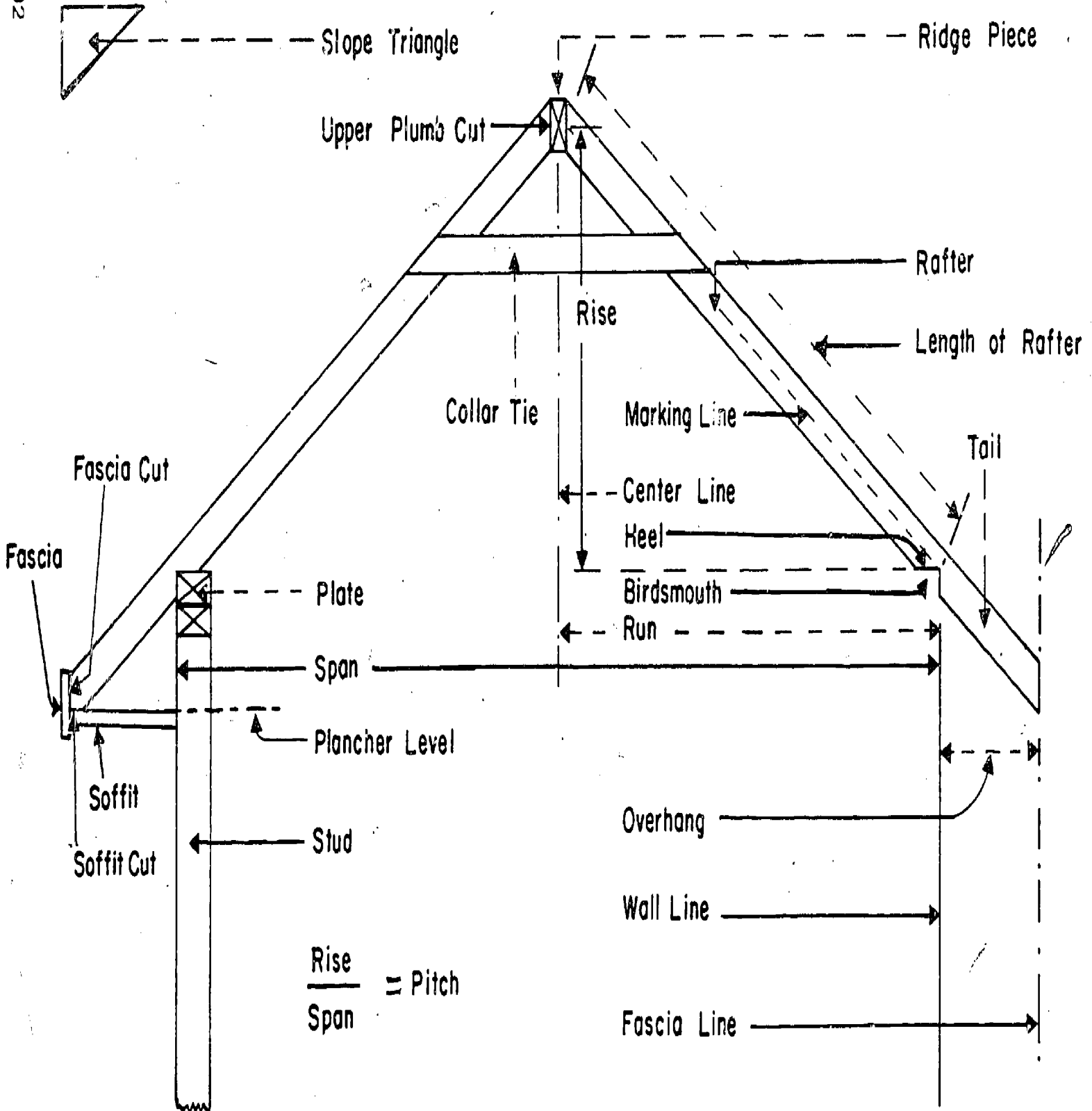

## UNIT H: AGRICULTURAL MECHANICS

### PROBLEM AREA: DEVELOPING ELECTRICAL WIRING SKILLS

#### SUGGESTIONS TO THE TEACHER:

This problem area is designed to provide the students with basic skills in residential and farm wiring. The recommended time for teaching this problem area is during the winter when outside activities are at a minimum. The estimated time for teaching this problem area is 4-6 weeks. About two weeks of this time should be classroom work, and depending upon the number of student exercises assigned, the balance as laboratory (shop) work. In order to teach this problem area the teacher should:

1. Have available the needed reference material.
2. Have available needed supplies and tools.
3. Make copies of the necessary student worksheets and recording charts.
4. Construct or have on hand a panel or wall where the circuit breaker and fuse boxes can be mounted.
5. Provide a source of the following:
  - a. Type NM and UF cable (14 gauge and 12 gauge).
  - b. 2 wire cable with ground (14 gauge and 12 gauge).
  - c. 3 wire cable with ground (14 gauge and 12 gauge).
  - d. Various sizes of solderless connectors.
  - e. Grounding clips and grounding screws, grounding pig tails.
  - f. Electric wiring kit available from VAS. (Rent one kit per 8 students in class.)
  - g. Tools needed include one electrician screw driver, needle nose pliers, linesman pliers, and diagonal cut pliers (optional) per student. Electricians' tool can replace the pliers. Assigning students in groups will reduce the amount of supplies needed.
  - h. A piece of 12 or 14 gauge cable (25') to use as a simulated feeder cable. (One end should contain an attachment plug for safety.)

The instructor is encouraged to conduct a local search to locate other supplementary materials for use with this problem area. The items in this problem area are for reference or modification as the instructor adapts these materials to his or her local situation.

## CREDIT SOURCES:

These materials were developed through a funding agreement, R-33-13-D-0362-466, with the Illinois State Board of Education, Department of Adult, Vocational and Technical Education, Research and Development Section, 100 North First Street, Springfield, Illinois 62777. Opinions expressed in these materials do not reflect, nor should they be construed as policy or opinion of the State Board of Education or its staff.

The teacher's guide, student worksheet, and test questions were developed by Dave Wilson, vocational agriculture instructor, St. Joseph High School, St. Joseph, Illinois, and Jerry Pepple, Agricultural Education Division, University of Illinois. Transparency masters and the transparency discussion guide were prepared by the Vocational Agriculture Service, University of Illinois. Suggestions and guidance in the development of these materials were provided by the Rural Core Curriculum Field Test Teachers. This problem area was reviewed by the following vocational agriculture teachers:

Dave Wilson, St. Joseph High School  
John Abell, Teutopolis High School  
Richard Seidel, Altamont High School  
Gene Bork, Forrest-Strawn-Wing High School  
Bob Whittington, Olney High School  
John Rentfrow, Shelbyville High School  
Max Tessier, Metamora High School

## TEACHER'S GUIDE

- I. Unit: Agricultural mechanics
- II. Problem area: Developing electrical wiring skills
- III. Objectives: At the end of this problem area, students will be able to:
  1. Correctly diagram circuits according to the NEC.
  2. Select the materials needed to wire selected exercises.
  3. Rough connect all junction boxes and install wire.
  4. Finish all rough connections within the junction boxes.
  5. Select the correct type of conductors.
  6. Make all connections to switches, splices, receptacles, lamp-holders, and circuit breakers and fuse boxes, according to NEC specifications.
  7. Locate and interpret information in the National Electrical Code.
  8. Use safe operating procedures at all times.
  9. Make necessary circuit connections into the circuit breaker and fuse box.
  10. Properly diagram electrical circuits using schematic symbols.
- IV. Suggested interest approaches:
  1. Promote class discussion on electrical wiring by asking students to relate experiences they have had with wiring electrical circuits.
  2. Invite a firefighter or other safety expert to class to discuss the hazards of having electrical wiring improperly installed in buildings and structures.
  3. Use flash cards or actual electrical wiring devices and have students try to identify them and when each is used.
  4. Let students examine electrical circuit examples which have been wired improperly. Have them identify the wiring mistakes in each example.
  5. Have students help unpack the VAS electrical wiring kit. Use VAS Filmstrip, "Unpacking Electrical Wiring Kit," and the inventory sheet to locate and identify electrical items.

V. Anticipated problems and concerns of students:

1. What is electricity?
2. What is voltage?
3. How is voltage measured?
4. What device is used to step up or step down voltage?
5. How can one determine the output of a transformer?
6. What are amperes?
7. What measures amps?
8. What is wattage?
9. How does one determine watts being used?
10. How many watts equal 1 horsepower?
11. What is a kilowatt?
12. How many foot pounds of work can one kilowatt do?
13. What are ohms?
14. How does one determine ohms?
15. What is the formula to calculate ohms?
16. What is the function of the underwriters laboratories?
17. What is GFCI?
18. What is the function of the grounding circuit?
19. How many amps can cause death?
20. What factors should you consider when planning for adequate wiring?
21. What is a service drop?
22. What factors determine the size of the feeders running from the load center to various buildings?
23. What is the rule for determining mechanical strength of feeder cables?
24. What is the relationship between the size of feeders and voltage drop?
25. What is the allowable voltage drop? (Power loads and lighting)

26. What is ampacity?
27. What is the formula for calculating voltage drop?
28. How does one connect a standby generator to an existing wiring system?
29. What types of standby generators are available?
30. How does one determine the size of the generator needed?
31. Where can one find details for connecting the standby generator to an electrical system?
32. What supplies are needed for electrical wiring?
33. What is the difference between Type T and TW wire?
34. What does Type UF wire mean?
35. Where is Type NM wire used?
36. How can we be sure our electrical installations are safe?
37. Why is it not recommended to use copper devices with aluminum conductors?

VI. Suggested learning activities and experiences:

1. Identify students' concerns and questions about electrical wiring. Establish student goals and objectives in electrical wiring. Use the Competency sheet to select essential job skills.
2. Use an interest approach to develop student curiosity about electrical wiring. Distribute copies of National Electrical Code and discuss purpose and content.
3. Conduct supervised study so students can answer the identified problems and concerns. During supervised study use one or more of the following teaching methods to promote effective student learning:
  - a. Use VAS units on electrical wiring.
  - b. Hand out worksheets to help students identify essential information concerning electrical wiring.
  - c. Use small groups to promote student work on selected worksheet questions.
  - d. Conduct demonstrations on electrical wiring techniques to help students understand electrical procedures.
  - e. Use NEC as a reference to answer identified problems and concerns.

4. Bring selected electrical items into the classroom and use VAS Unit 3016a, "Electrical Wiring Procedures," to develop an understanding of diagraming electrical circuits.
5. Demonstrate how to properly diagram electrical circuits. Assign circuits for students to diagram.
6. Use transparencies to demonstrate proper electrical symbols and their uses.
7. Demonstrate the proper technique to use when stripping electrical wiring to avoid damaging the conductors.
8. Have students demonstrate their ability to connect electrical cable and conduit to switch boxes.
9. Demonstrate how to properly connect conductors to receptacles.
10. Distribute VAS Unit 3012a, "Electrical Hazards in Home, Farm, and Business," and have students prepare a 3-5 minute report on electrical safety.
11. Have FFA chapter safety committee develop goals and objectives on electrical safety for Program of Activities.
12. Have students identify activities and make entries on electrical safety in their Illinois Foundation Record book on Safety.
13. Divide the class into groups and have them conduct a "Survey of Electrical Hazards," using the forms printed in VAS Unit 3012a.
14. Distribute and discuss VAS Unit 3016a, "Electrical Wiring Procedures," and using VAS Electrical Wiring Kit have students complete assigned exercises. Use VAS transparencies on Electrical Wiring as key.
15. Conduct interest approach on planning for electrical wiring. Take field trip to a selected location and have class design the electrical wiring for a farm structure. If possible, have class complete the wiring of the structure. Have wiring inspected by qualified electrician.
16. Test students on their knowledge and skill of electrical wiring by using sample test questions in this problem area and by using identification and skill tests.

VII. Application procedures:

1. The main purpose of this problem area is to enable students to identify and prevent electrical hazards around the home, farm and business.



2. The students should be able to apply their knowledge and skill of electrical wiring to their home situation or place of employment.

#### VIII. Evaluation:

1. Prepare and administer a paper and pencil test covering electrical diagrams, identification, and electrical fundamentals.
2. Evaluate students' ability to locate and interpret information in the NEC.
3. Evaluate students' ability to properly diagram and wire electrical circuits.
4. Evaluate students' participation in chapter electrical safety program.
5. Evaluate students' Illinois Foundation Record book on Safety.

#### IX. References:

Vocational Agriculture Service, 1401 South Maryland Drive, Urbana, Illinois 61801.

1. VAS Unit 3003b, Planning For Electrical Wiring
2. VAS Unit 3012a, Electrical Hazards in Home, Farm and Business
3. VAS Unit 3016a, Electrical Wiring Procedures
4. VAS Transparencies on Electrical Wiring
5. VAS Electrical Wiring Exercises
6. VAS Electrical Wiring Kit
7. National Electrical Code (can be obtained through VAS)

## COMPETENCY INVENTORY

1. Student has no knowledge of competency.
2. Student has read about competency.
3. Student has seen competency performed.
4. Student has performed competency.
5. Student has performed competency without supervision.
6. Student does possess skill.
7. Student does not possess skill.

Competency	Circle One						
1. Use safety measures in electrical wiring	1	2	3	4	5		
2. Select correct fuse sizes	1	2	3	4	5		
3. Replace fuses	1	2	3	4	5		
4. Make electrical splices	1	2	3	4	5		
5. Repair electrical cords	1	2	3	4	5		
6. Wire on-off switches	1	2	3	4	5		
7. Select wire sizes	1	2	3	4	5		
8. Attach wires to terminals	1	2	3	4	5		
9. Install light fixtures	1	2	3	4	5		
10. Wire three- and four-way switches	1	2	3	4	5		
11. Wire buildings, and structures according to NEC standards	1	2	3	4	5		
12.	1	2	3	4	5		
13.	1	2	3	4	5		
14. Know and explain electrical terms (volts, amps, watts, ohms, etc.)						6	7
15. Use and understand NEC						6	7
16.						6	7
17.						6	7

These competencies are outlined in the National Ag Occupations Competency Study, 1978, for entry level positions of agriculture productions.

Name \_\_\_\_\_

Date \_\_\_\_\_

STUDENT WORKSHEET  
ELECTRIC VOLTAGE PROBLEMS

Directions: Use the transformer formula and calculate the (out) voltage from each of the following transformers.

(Use VAS Unit 3003b as reference)

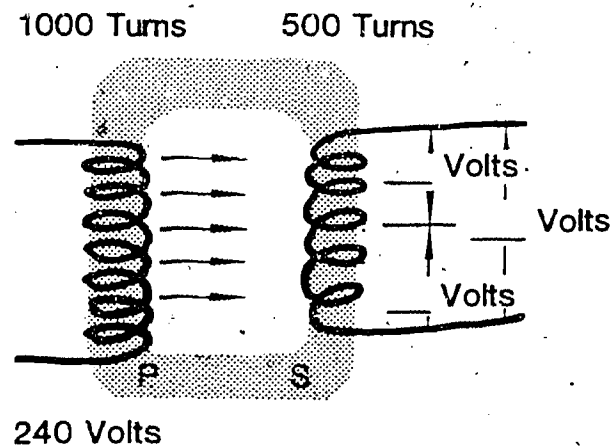
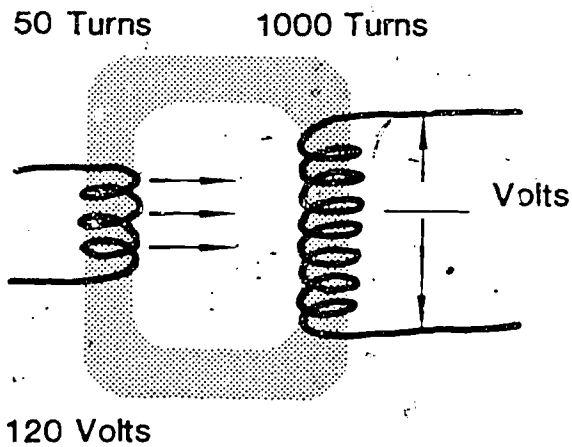
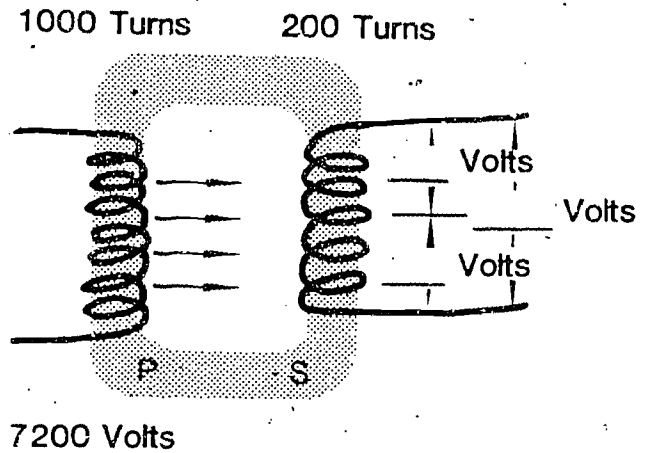
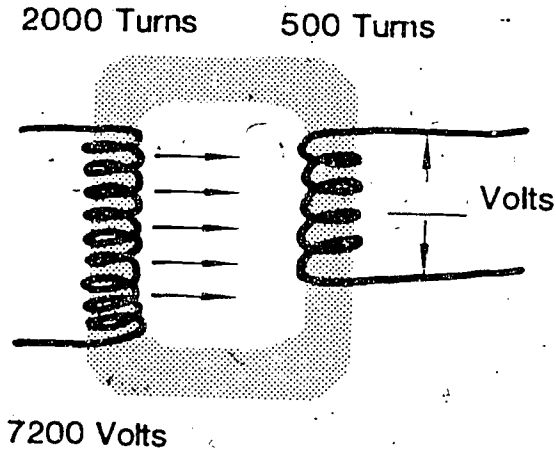

STUDENT WORKSHEET  
ELECTRICITY PROBLEMS

Directions: Answer the following and show your work. Use equations found on page 5 of VAS Unit 3003b.

1. How many amps are being used by a 100 watt light bulb on a 120 volt current?
2. How many kilowatts are used by the light bulb in the #1 problem per week if the bulb burns continuously? (100 watts per hour)
3. How many volts are required by a 100 watt bulb pulling .9 amps?
4. How many amps are used by a 1500 watt heater connected to a 120 volt current?

108

5. How many ohms should one expect from a toaster pulling .86 amps on a 120 volt circuit?

6. Using a 120 volt source, what size fuse would be needed for the following? (Assume 125% load protection)

Coffee pot	1000 watts
Stereo	1800 watts
Humidifier	80 watts
3 Light bulbs	180 watts

7. What size fuse is needed for the following circuit? (120 volt service and 125% load capacity)

Electric blanket	1500 watts
Reading light	100 watts
Night light	6 watts
Alarm clock	16 watts

8. How much would it cost to operate three 100 watt light bulbs for 8 hours per day? (Electricity costs 7¢ per kwh.)

















9. How much does it cost to operate a dryer fan continuously when using an electric motor pulling 9600 watts? Calculate the cost per hour, per day, per week, and per month (30 days). (Assume electricity costs 6.75¢ per kwh.)
10. Using the rate schedule found on page 6 of VAS Unit 3003b, calculate the cost to use 780 kwh of electricity.

# STUDENT WORKSHEET

## ELECTRICAL WIRING PROCEDURES AND DIAGRAMS

(Refer to VAS Unit 3016a)

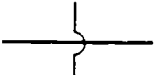
1. What do each of the following represent?

a.		b.		c.		d.		e.	
f.		g.		h.		i.		j.	
k.		l.		m.		n.		o.	
p.		q.							

2. Connect the neutral line from the source directly to \_\_\_\_\_ . This line is always \_\_\_\_\_ (a color) and never switched.
  
3. If you had three switches controlling one light, what kinds would they be?
  
4. The conductor going to the hot side of a receptacle should be or in color.
  
5. If you had two switches controlling one light what kinds would they be?
  
6. Any \_\_\_\_\_ lines must not be attached to or taken from a switch.
  
7. If you are working with two wire cables, one wire will be \_\_\_\_\_ and the other \_\_\_\_\_. If it is 3-wire cable, the wires will be white, \_\_\_\_\_, and \_\_\_\_\_.

8. All wires must be attached to terminals or \_\_\_\_\_ at all switches, receptacles, and junction boxes.

9. Is a white wire always neutral? Explain.

Diagram the following in the space provided. Show all wiring as cable. Omit all bare grounding wires. All duplex receptacles are unswitched.

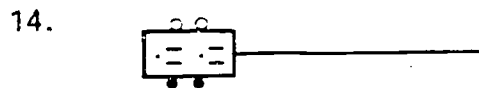
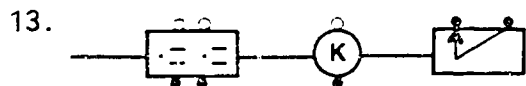
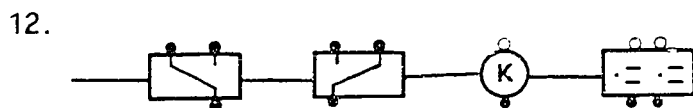
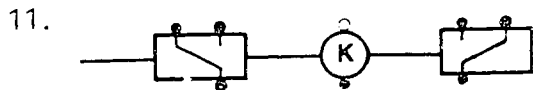
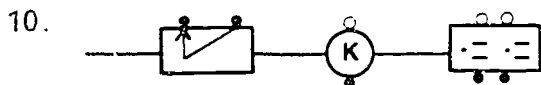

110



15.

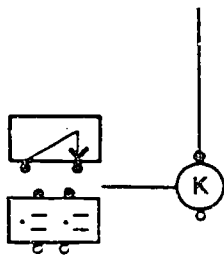

16.

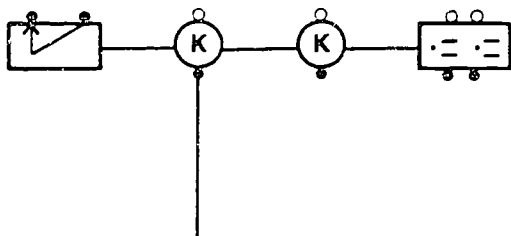

17.

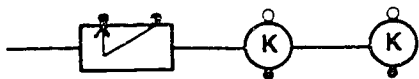

18.

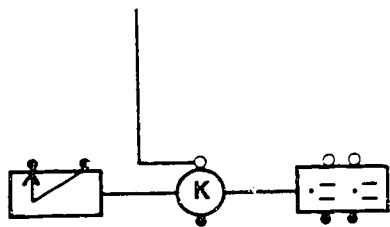

19.

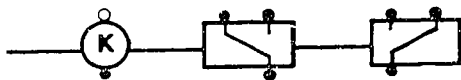

JOB SHEET  
CONNECTING ELECTRICAL CIRCUITS

Objectives:

1. To be able to identify and select necessary electrical items and tools for specific jobs.
2. To be able to connect cable and conduit to outlet boxes.
3. To be able to properly prepare and connect electrical conductors to receptacles.
4. To be able to diagram electrical circuits.

Materials:

1. Electricians tools
2. Electrical wiring exercises
3. Electrical wiring kit

Procedure:

1. Assign each student specific wiring exercises to complete.
2. Demonstrate how to properly connect conduit and conductors to switch boxes.
3. Explain the importance of neatness when doing electrical wiring.
4. Have students complete a diagram of the wiring exercises before they start assembling the circuits.
5. Have students wire their assigned exercises.

Questions:

1. When should conduit be used instead of cable?
2. Why do you not need a continuous ground wire when using metal conduit?

3. How much free conductor should be left at each outlet and switch box? Why?
4. What class of fire is an electrical fire and what type of extinguisher should you use to control it?
5. What first aid treatment should be given to a victim of electrical shock?

Observation:

Evaluate the completed exercises by using the following grading scale.

<u>Items</u>	<u>possible</u>	<u>earned</u>
Proper polarity	(10)	_____
Proper grounding	(10)	_____
Proper cable ripping	(10)	_____
Proper wire stripping	(10)	_____
Conductors to outlet boxes	(10)	_____
Conductors to receptacles	(10)	_____
Functional and neat	(10)	_____
Attitude and work habits	(10)	_____
Wiring diagrams	(20)	_____
TOTAL SCORE	(100)	_____

Conclusions:

Identify possible situations where these skills could be used to benefit your S.O.E.P. or home situation.

TEACHER'S KEY  
STUDENT WORKSHEET  
ELECTRIC VOLTAGE PROBLEMS

Directions: Use the transformer formula and calculate the (out) voltage from each of the following transformers.

(Use VAS Unit 3003b as reference)

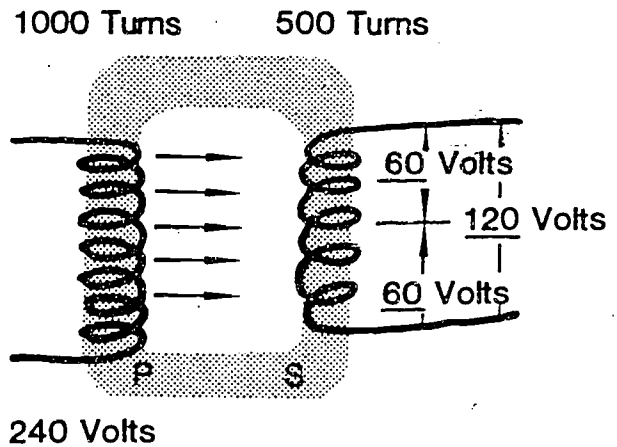
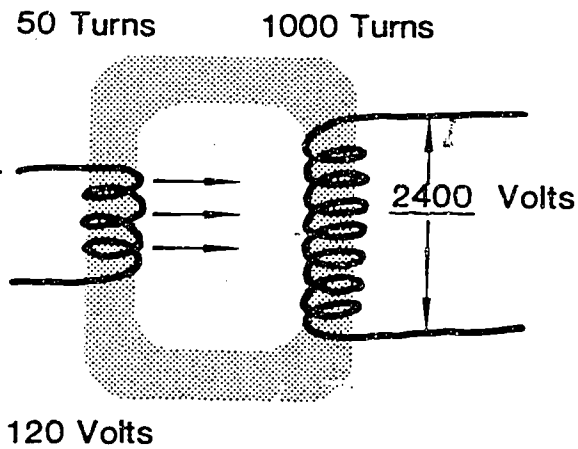
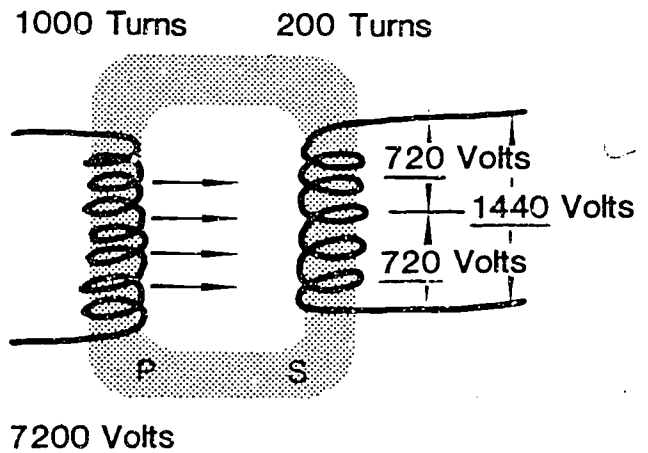
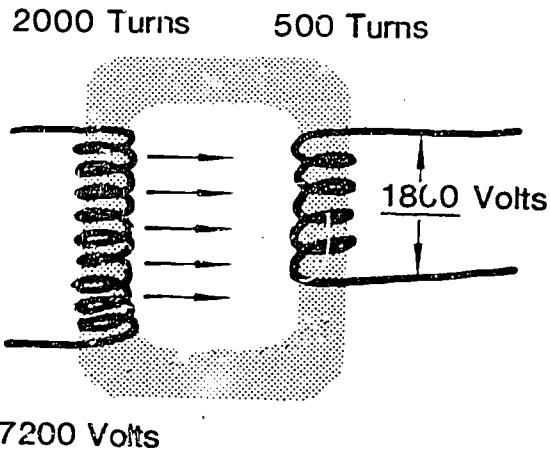

TEACHER'S KEY  
STUDENT WORKSHEET  
ELECTRICITY PROBLEMS

Directions: Answer the following and show your work. Use equations found on page 5 of VAS Unit 3003b.

1. How many amps are being used by a 100 watt light bulb on a 120 volt current?

$$\frac{100 \text{ W}}{120 \text{ V}} = .8333 \text{ amps.}$$

2. How many kilowatts are used by the light bulb in the #1 problem per week if the bulb burns continuously? (100 watts per hour)

$$\frac{100 \text{ watts/hr.}}{24 \text{ hrs./day}} = \frac{2400 \text{ watts/day}}{2400 \text{ watts/day}} = 2.4 \text{ kw/day}$$
$$\frac{2.4 \text{ kw/day}}{7} = \frac{16.8 \text{ kw/week}}{16.8 \text{ kw/week}}$$

3. How many volts are required by a 100 watt bulb pulling .9 amps?

$$\frac{100 \text{ watts}}{.9 \text{ amps}} = 111 \text{ volts}$$

4. How many amps are used by a 1500 watt heater connected to a 120 volt current?

$$\frac{1500 \text{ watts}}{120 \text{ volts}} = 12.5 \text{ amps.}$$

5. How many ohms should one expect from a toaster pulling .86 amps on a 120 volt circuit?

$$\frac{120 \text{ volts}}{.86 \text{ amps}} = 140 \text{ ohms.}$$

6. Using a 120 volt source, what size fuse would be needed for the following? (Assume 125% load protection)

Coffee pot	1000 watts				
Stereo	1800 watts				
Humidifier	80 watts				
3 Light bulbs	180 watts				
	3060 watts				
					$\frac{3060 \text{ watts}}{120 \text{ volts}} = 25.5 \text{ amps.}$
					$\frac{25.5 \text{ amps}}{1.25 \text{ safety}} = 20.4 \text{ amps}$
					32.00 amps

7. What size fuse is needed for the following circuit? (120 volt service and 125% load capacity)

Electric blanket	1500 watts				
Reading light	100 watts				
Night light	6 watts				
Alarm clock	16 watts				
	1622 watts				
					$\frac{1622 \text{ watts}}{120 \text{ volts}} = 13.5 \text{ amps}$
					$\frac{13.5 \text{ amps}}{1.25 \text{ safety}} = 10.8 \text{ amps}$
					17.00 amps.

8. How much would it cost to operate three 100 watt light bulbs for 8 hours per day? (Electricity costs 7¢ per kwh.)

$$3 \times 100 = 300 \text{ watts}$$

$$\frac{300 \text{ watts}}{1000} = 0.3 \text{ kwh}$$

$$0.3 \text{ kwh} \times 8 \text{ hrs.} = 2.4 \text{ kwh}$$

$$2.4 \times 7 = 16.8 \text{ ¢ per 8 hour day}$$

9. How much does it cost to operate a dryer fan continuously when using an electric motor pulling 9600 watts? Calculate the cost per hour, per day, per week, and per month (30 days). (Assume electricity costs 6.75¢ per kwh.)

$$9600 \text{ watts} = 9.6 \text{ kw}$$

$$\begin{aligned} \text{cost/hr.} &= \$6.75 \text{ or } \$6.75 \\ \text{cost/day} &= \$6.75 \text{ or } 24 \text{ hr.} \times \$6.75 = \$162.00 \\ \text{cost/wk.} &= \$1170.00 \\ \text{cost/mo.} &= \$3510.00 \end{aligned}$$

10. Using the rate schedule found on page 6 of VAS Unit 3003b, calculate the cost to use 780 kwh of electricity.

$$\begin{aligned} 50 \text{ kwh @ } 5.4\text{¢} &= \$ 2.70 \\ 50 \text{ kwh @ } 3.2\text{¢} &= \$ 1.60 \\ 200 \text{ kwh @ } 2.6\text{¢} &= \$ 5.20 \\ 480 \text{ kwh @ } 2.2\text{¢} &= \$10.56 \end{aligned}$$

---

$$\text{Total Cost} = \$20.06$$

117

















STUDENT WORKSHEET

TEACHER'S KEY

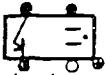
ELECTRICAL WIRING PROCEDURES AND DIAGRAMS

(Refer to VAS Unit 3016a)

1. What do each of the following represent?

- |  |  |  |  |  |
|--|--|--|--|--|
| a.  | b.  | c.  | d.   | e.  |
| <u>Single Pole Switch</u>  | <u>Keyless lampholder</u>  | <u>Duplex receptacle</u>   | <u>3-way switch</u>  | <u>blackwire</u>   |
| f.  | g.  | h.  | i.   | j.  |
| <u>bare wire</u>   | <u>fused receptacle</u>  | <u>ground screw</u>  | <u>white wire</u>  | <u>pullchain receptacle</u>  |
| k.  | l.  | m.  | n.  | o.  |
| <u>brass screw</u>   | <u>switch and receptacle</u>   | <u>splice</u>  | <u>silver screw</u>  | <u>cross-over</u>  |
| p.  | q.  |  |  |  |
| <u>4-way switch</u>  | <u>red wire</u>  |  |  |  |

- Connect the neutral line from the source directly to lampholders or receptacles. This line is always white (a color) and never switched.
- If you had three switches controlling one light, what kinds would they be? two 3-way, one 4-way
- The conductor going to the hot side of a receptacle should be black or red in color.
- if you had two switches controlling one light what kinds would they be? two 3-way
- Any neutral lines must not be attached to or taken from a switch.
- If you are working with 2-wire cables, one wire will be black and the other white. If it is 3-wire cable, the wires will be white, black, and red.



8. All wires must be attached to terminals or spliced at all switches, receptacles, and junction boxes.

9. Is a white wire always neutral? Explain. No, the white wire may be hot in a switch loop.

Diagram the following in the space provided. Show all wiring as cable. Omit all bare grounding wires. All duplex receptacles are unswitched.

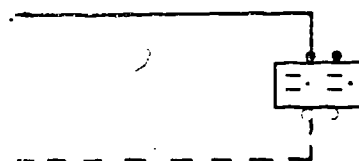
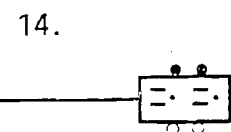
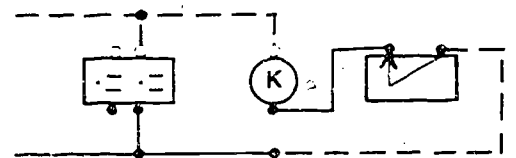
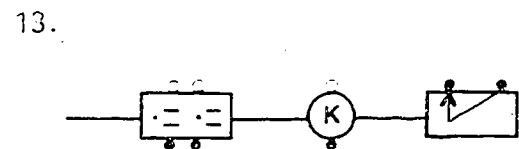
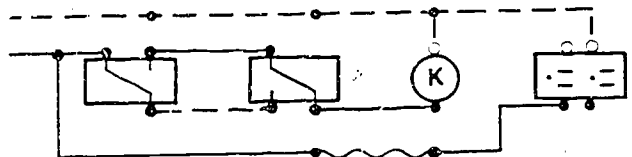
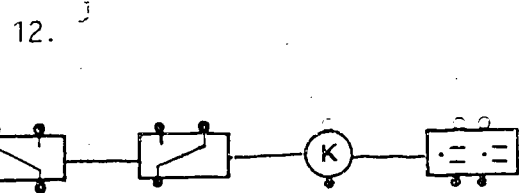
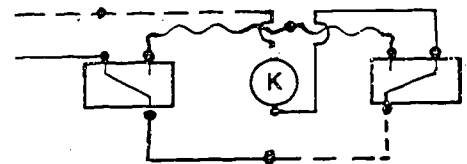
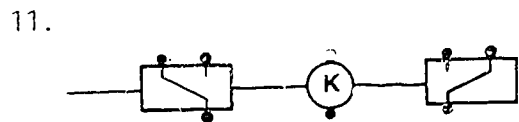
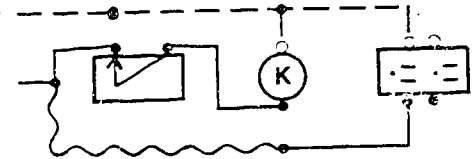
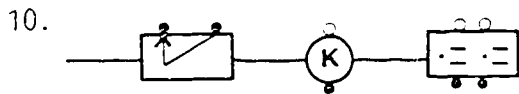

15.

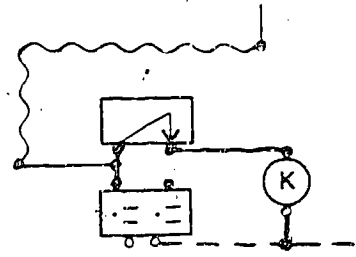
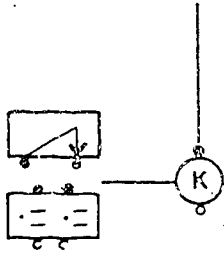

16.

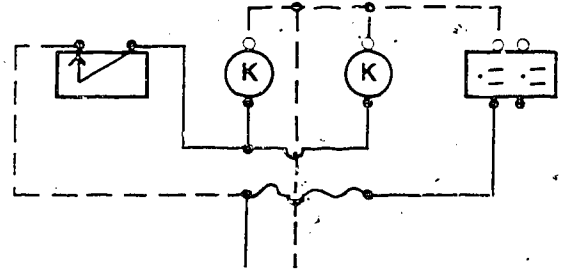
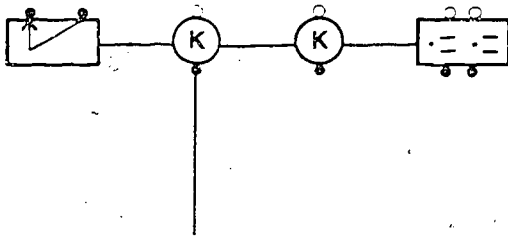

17.

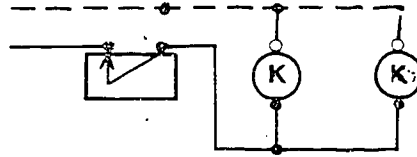
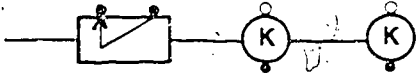

18.

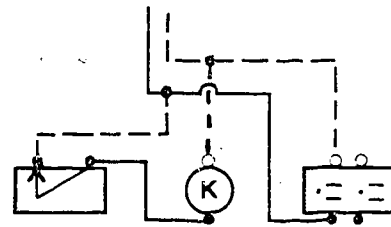
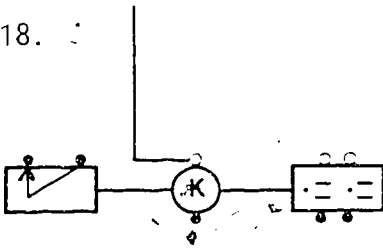

19.

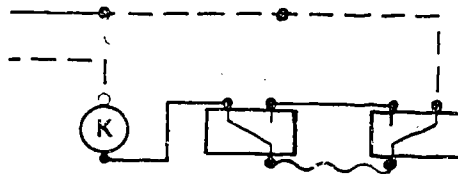
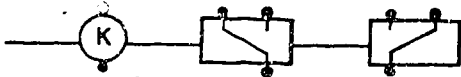

Pictorial

Electrical Symbols (i)

Schematic



Black Wire



White Wire



Red Wire

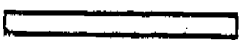

Bare Wire

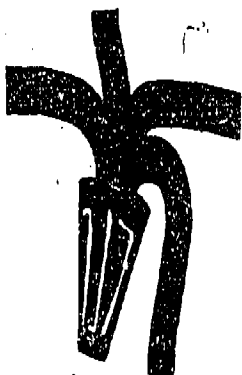

Wires Spliced

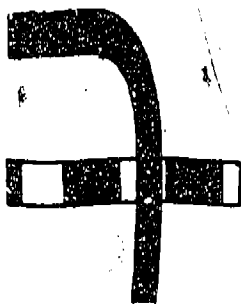
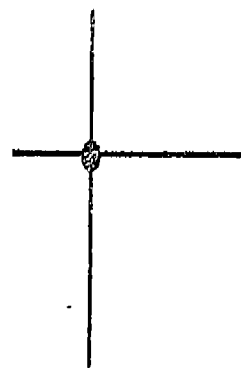

Wires Crossing - Not Spliced

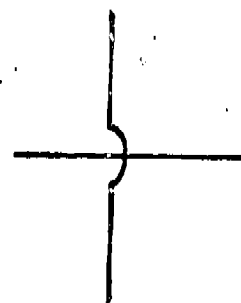

Silver - Colored Terminal



Brass - Colored Terminal



Green - Colored Terminal



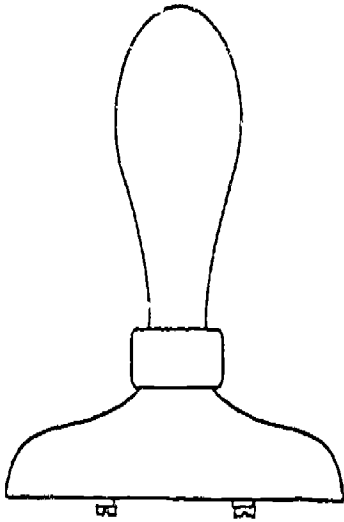

Keyless Lampholder

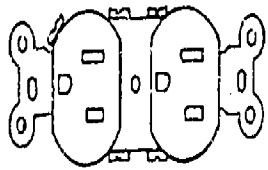

Duplex Receptacle

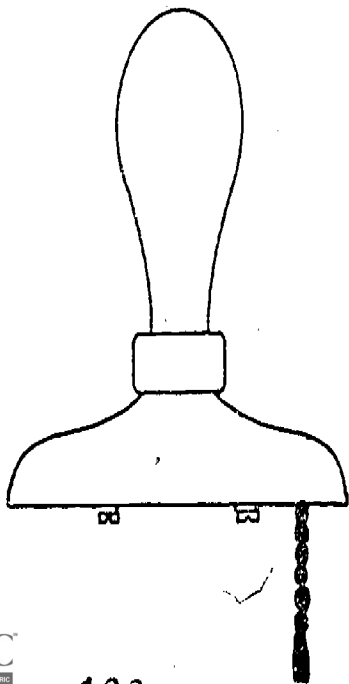
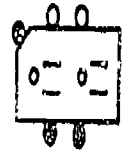

Pull Lampholder



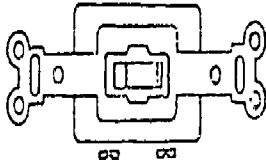

Single - Pole Switch

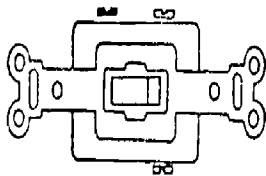
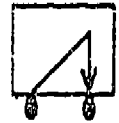

Three - Way Switch

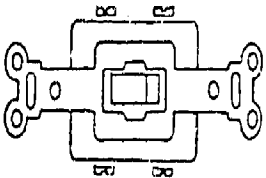
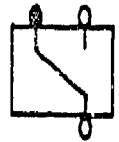

Four - Way Switch

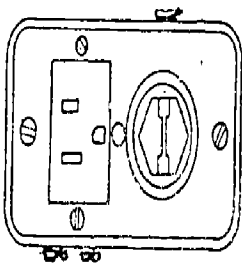
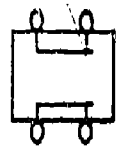

Fused Receptacle

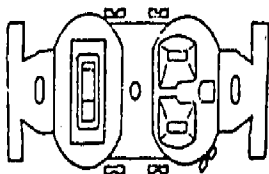
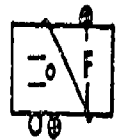

Single - Pole Switch and Receptacle

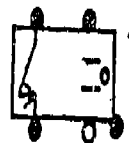

111-H-2-31

# KEYLESS LAMPHOLDER CONTROLLED BY A SINGLE-POLE SWITCH

DIAGRAM A

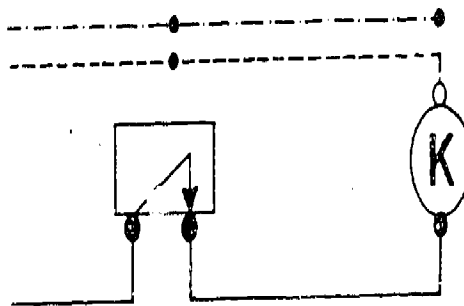
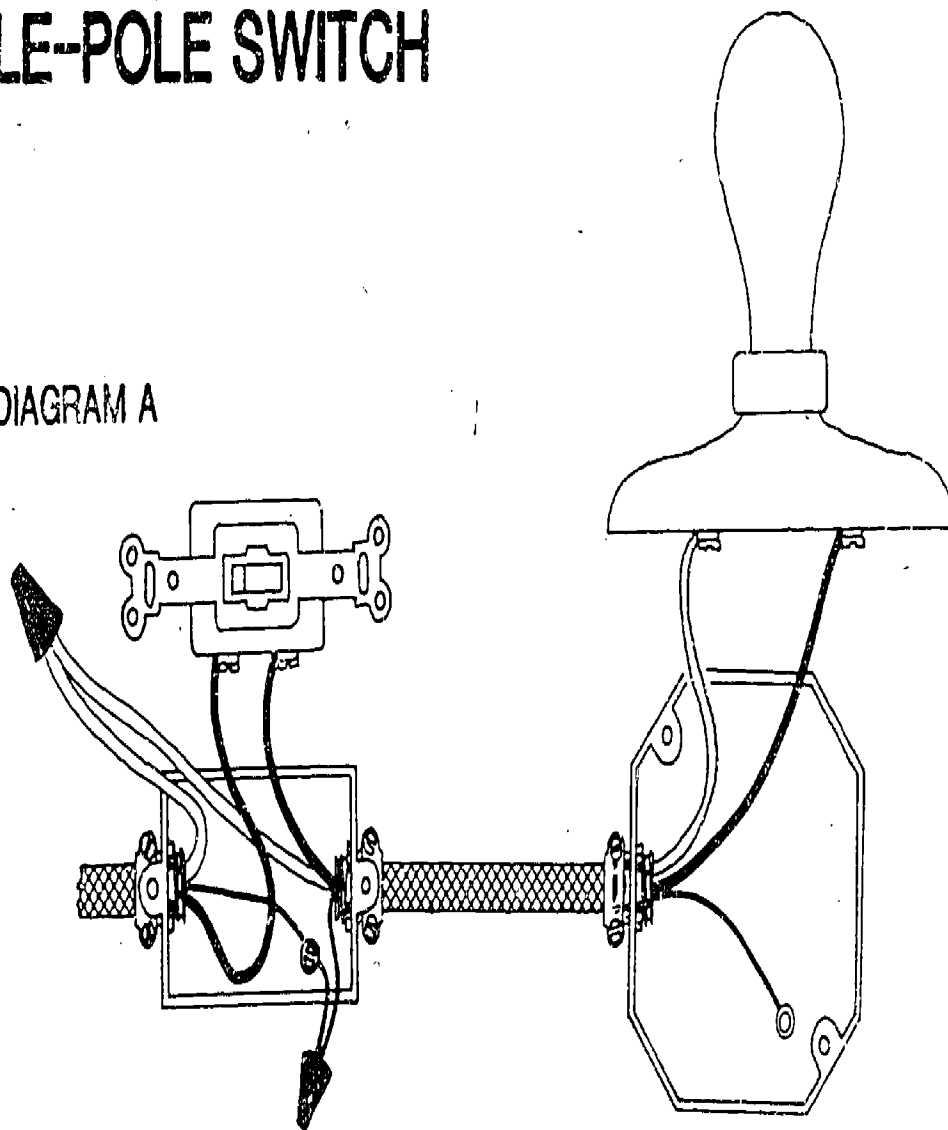

# EYLESS LAMPHOLDER CONTROLLED BY A SINGLE-POLE SWITCH

DIAGRAM B

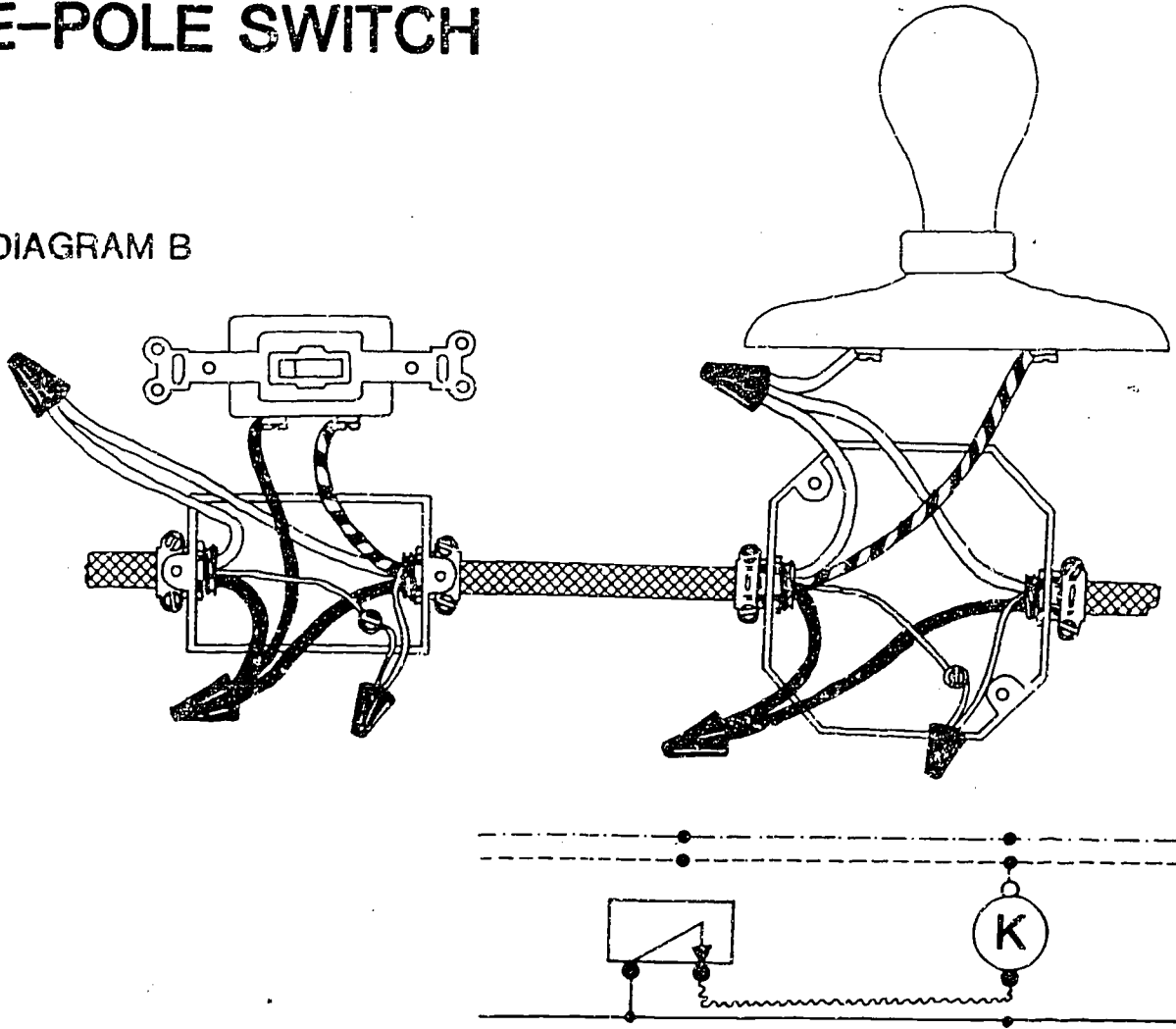

# KEYLESS LAMPHOLDER CONTROLLED BY A SINGLE-POLE SWITCH

DIAGRAM C

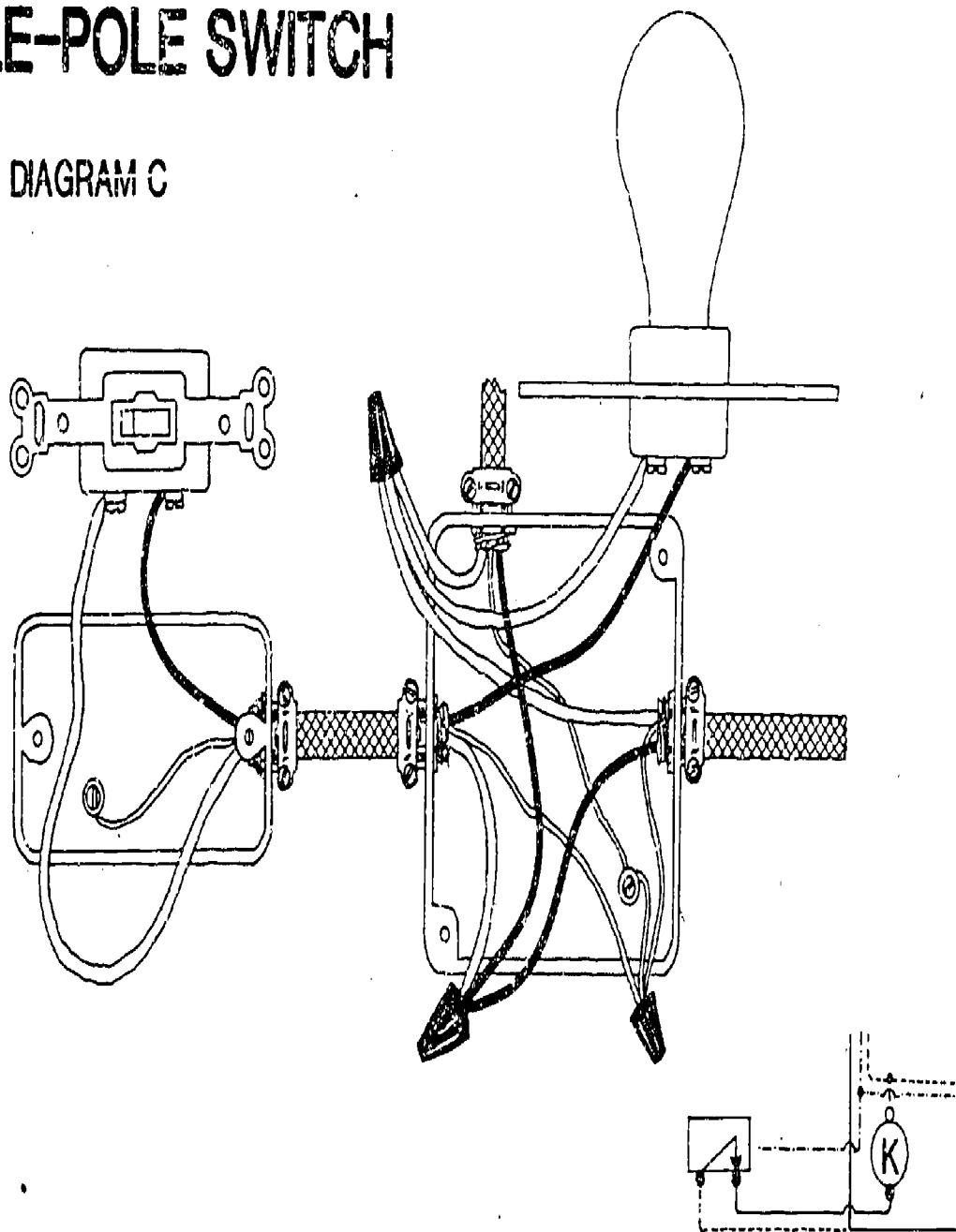

13j

III-H-2-34

13i



# KEYLESS LAMPHOLDER CONTROLLED BY TWO 3-WAY SWITCHES

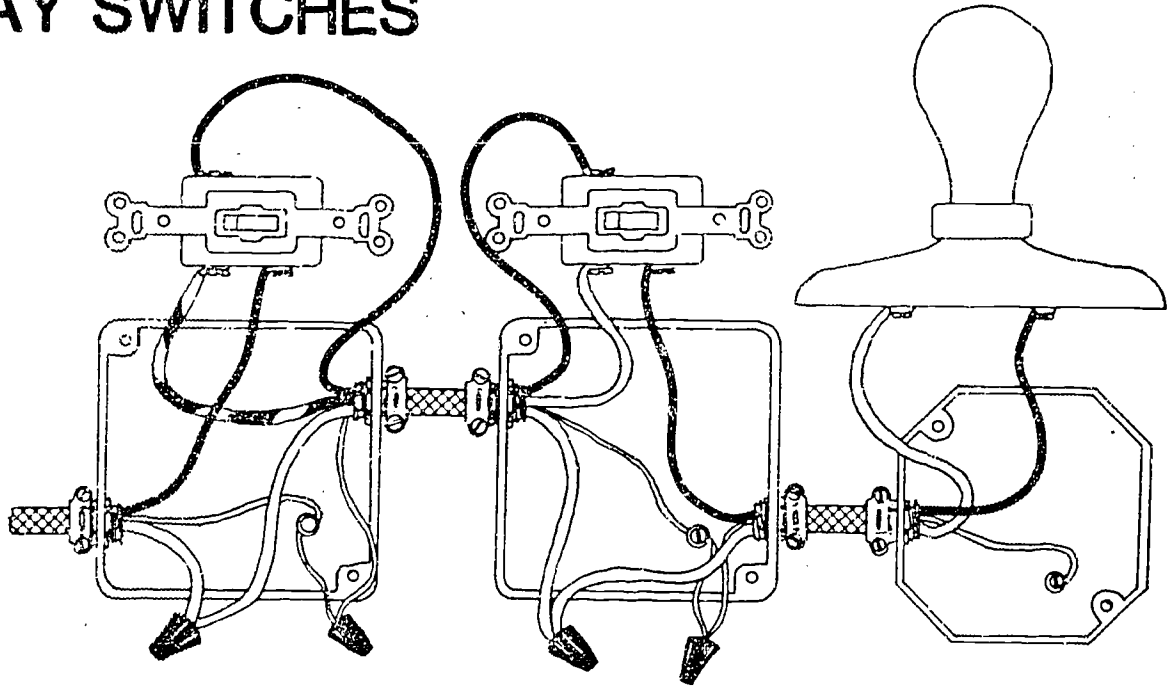
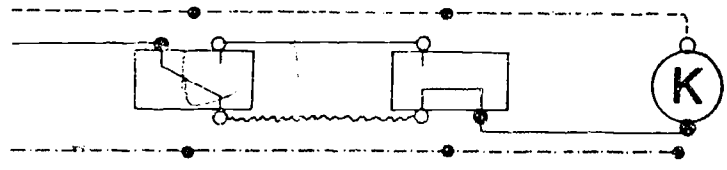
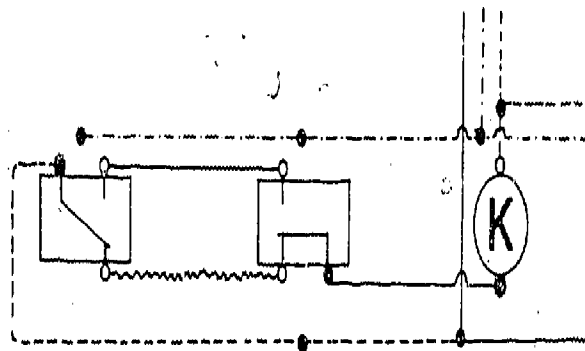
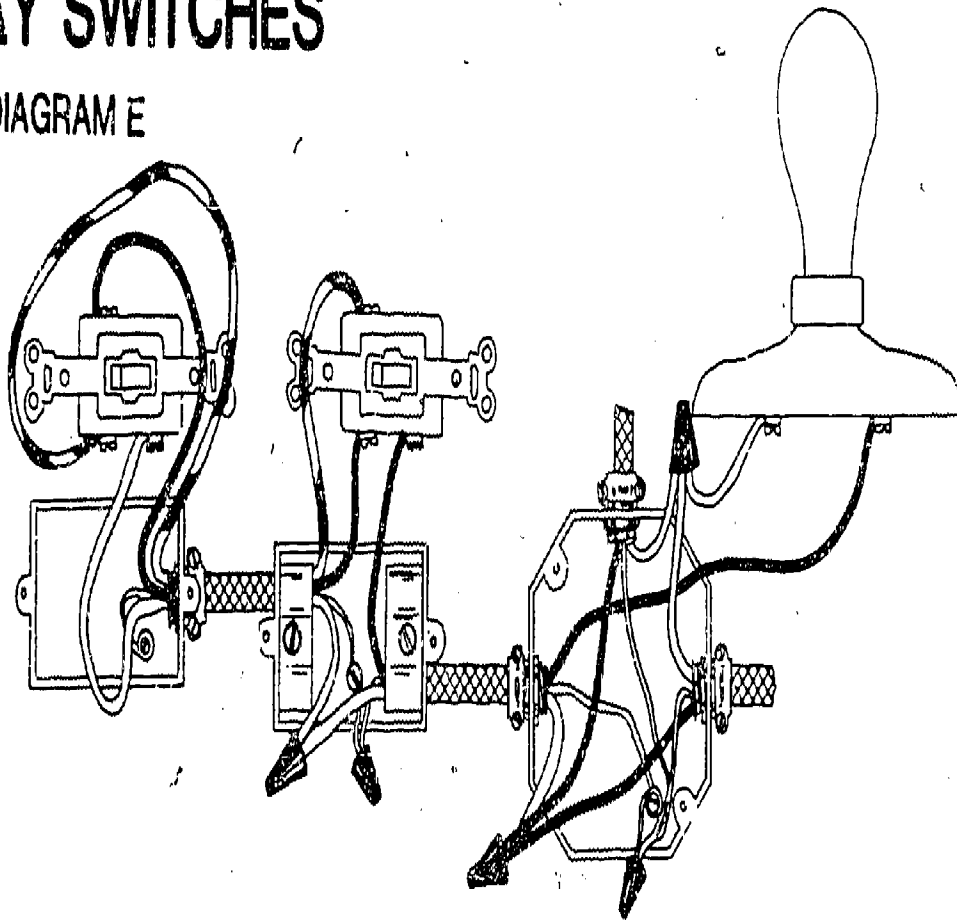

DIAGRAM D



# KEYLESS LAMPHOLDER CONTROLLED BY TWO 3-WAY SWITCHES

DIAGRAM E



TRANSPARENCY DISCUSSION GUIDE  
DEVELOPING ELECTRICAL WIRING SKILLS

- I. Transparencies - ELECTRICAL SYMBOLS  
i, iia, and iiaa
  - A. Use these transparencies as an instructional aid when students are learning to diagram electrical exercises.
  - B. Have students name the item represented by each symbol.
- II. Transparencies - WIRING EXERCISES  
DIAGRAMS A-E
  - A. Use these transparencies to give students practice in diagramming selected exercises.
  - B. Point out key procedures which students should observe during their wiring assignments.
  - C. Identify proper wiring of "hot" wire and "neutral" wire in various wiring situations.
  - D. Have students use the National Electrical Code to verify wiring procedures, such as box capacity, size of wires, number of wires per box, use of switches in conductors, etc.

## SAMPLE TEST QUESTIONS

### TEACHER'S KEY

#### ELECTRICAL WIRING

I. Matching. Fill in the blanks with the answer that most completely answers the question.

D 1. The flow of tiny particles called electrons is

- a. EMF.
- b. magnetism.
- c. power.
- d. electric current.

C 2. Electrical energy for this area is generated by

- a. gasoline engines.
- b. diesel engines.
- c. steam turbines.
- d. hydro-power.

A 3. The force that causes electrons to flow is called

- a. volts.
- b. amps.
- c. ohms.
- d. watts.

B 4. What instrument can be used to step up or step down electrical current?

- a. micro-unit
- b. transformer
- c. voltmeter
- d. magnets

C 5. An ammeter measures which of the following?

- a. ohms
- b. resistance
- c. current
- d. volts

B 6. Electrical resistance is measured in

- a. amps.
- b. ohms.
- c. volts.
- d. watts.

- A 7. Insulators have a resistance level that is
- high.
  - low.
  - average.
  - any of the above
- C 8. UL represents what?
- underwriters label
  - Uncle Louie
  - Underwriters Laboratories
  - underground laboratory
- A 9. The meter or load center should be located
- near the center of the area served.
  - close to a water source in case of fire.
  - underground.
  - near the road.
- A 10. What is the wire that connects power from the pole to the house named?
- feeder wire
  - entrance head cable
  - all of the above
  - none of the above
- B 11. Number 14 wire is \_\_\_\_\_ than number 10 wire.
- larger
  - smaller
  - a different color
- B 12. When wiring with metallic conduit, one \_\_\_\_\_ need a bare ground wire.
- does
  - does not
- C 13. A concrete slab patio is considered a \_\_\_\_\_ electrical location.
- dry
  - wet
  - damp
- C 14. A 4-way switch can be used with
- one 3-way switch.
  - two or three 3-way switches.
  - two 3-way switches.
  - any number of 3-way switches but with at least two 4-way switches.

- B 15. The minimum length of free conductor that shall be left at each outlet or switch box is
- a. 4 inches of wire.
  - b. 6 inches of wire.
  - c. 2 inches of wire.
  - d. 8 inches of wire.
- C 16. The maximum number of wires permitted under a screw is
- a. 2 wires.
  - b. 3 wires.
  - c. 1 wire.
  - d. 4 wires.
- B 17. The sharpest bend permitted in nonmetallic cable is \_\_\_\_\_ degrees.
- a. 10
  - b. 45
  - c. 80
  - d. 120
- A 18. It becomes necessary to use the white wire as the hot line to the switch in a
- a. switch loop connection.
  - b. pull-chain receptacle.
  - c. keyless receptacle.
  - d. 3-way switch.
- A 19. To control a light from two places use
- a. two, 3-way switches.
  - b. three, 3-way switches.
  - c. two, single pole switches.
  - d. any of the above
- D 20. To control a light from three places use
- a. two, 3-way and 1 single pole switches.
  - b. three, 3-way switches.
  - c. three, single pole switches.
  - d. one, 4-way and two, 3-way switches.

II. True or False. Place the correct answer in the blank next to the number.

- T 1. The grounded conductor shall be permanent, continuous, and shall have ample carrying capacity.
- T 2. Service from one building to another should not pass through another building.

- T   3. All 3-way and 4-way switches shall be wired so that all switching is done in the ungrounded circuit conductor.
- T   4. It is usually true that where a dead short occurs a fuse will blow.
- F   5. Ground rods and clamps are not important in farm and city dwellings.
- F   6. Three conductor self-supporting service drop wire is usually found connecting circuits inside buildings.
- F   7. Split bolt connectors should be soldered after tightening.
- T   8. Pennies should never be used in the place of fuses.
- F   9. Ground-fault circuit protection is not required for outdoor receptacle outlets.
- T   10. A blown fuse is usually a warning signal that the circuit is overloaded.
- T   11. Ammeters are hooked in series with a circuit.
- F   12. Glass is not a good insulator.
- T   13. Electrical equipment should be stamped with a UL.
- T   14. Many electrical fires are due to faulty wiring.
- F   15. It is a good idea to wrap extension cords around nails.
- T   16. It is not safe to put extension cords under carpets because of fire.
- F   17. Volts equals amps times watts.
- T   18. Ohms measures resistance.
- T   19. Amps times ohms equals volts.
- T   20. The circular mil is used to indicate the size of wire.

III. Complete the following problems.

1. Complete the diagram for the ohm's law equation.

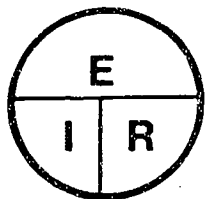

133

2. Complete the diagram for the power equation.

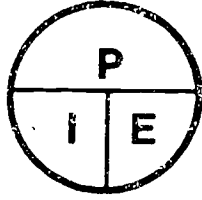

3. If a grain dryer operates on 240 volts and 50 amps, how many watts of electricity does it use?

ans. 12,000 watts

$$240 \times 50 = 12,000 \text{ watts}$$

4. If a spotlight operated on 120 volts and uses 4 amps, what is the resistance of the circuit?

ans. 30 ohms

$$\frac{120}{4} = 30 \text{ ohms}$$

5. If a grain auger motor operates on 115 volts and uses 600 watts of electricity, what is the ampere rating of the motor?

ans. 5.2 amps

$$\frac{600}{115} = 5.2 \text{ amps}$$















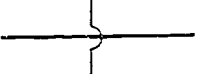

6. If a milk cooler compressor uses 12 amps and has a resistance of 20 ohms, what is the voltage requirement of the compressor?

ans. 240 volts

$$12 \times 20 = 240 \text{ volts}$$



IV. Matching. Place the letter of the best answer in the blank next to the number.

- C   1. 
- A   2. 
- B   3. 
- H   4. 
- L   5. 
- D   6. 
- E   7. 
- I   8. 
- M   9. 
- J   10. 
- G   11. 
- O   12. 
- P   13. 
- Q   14. 
- F   15. 
- N   16. 
- K   17. 

- A. Single pole switch
- B. Duplex receptacle
- C. Keyless lampholder
- D. Pull-chain lampholder
- E. Three-way switch
- F. Single pole switch and receptacle
- G. Four-way switch
- H. Black wire
- I. Wires crossing not spliced
- J. Fused receptacle
- K. Wires spliced
- L. White wire
- M. Red wire
- N. Bare wire
- O. Silver colored terminal
- P. Brass colored terminal
- Q. Green colored terminal

## V. Diagraming Circuits

1. Diagram a keyless lampholder controlled by a single pole switch with an unswitched line in at the receptacle.



2. Diagram a keyless lampholder controlled by a single pole switch and an unswitched duplex receptacle, with an unswitched line in at the keyless lampholder.



3. Diagram a keyless lampholder controlled by two 3-way switches, with a line in through the switches.



4. Diagram a keyless lampholder controlled by two 3-way switches, with a line in at the keyless lampholder.



## UNIT H: AGRICULTURAL MECHANICS

### PROBLEM AREA: ADJUSTING AND MAINTAINING PLANTING EQUIPMENT

#### SUGGESTIONS TO THE TEACHER:

This problem area is designed for use with eleventh grade or advanced students in vocational agriculture programs. The recommended time for teaching this problem area is during the spring. This period is recommended because the students will be able to make planter adjustments in the field. The students could also make adjustments on the drill in the field.

The estimated instructional time for this problem area is 10 to 15 days, depending on how far the teacher wishes to go in developing the skills required to adjust planters and drills. Time will also need to be allotted for maintenance of the equipment. If the students are to be involved in a large number of field activities, the instructional time will need to be increased.

Instructors are encouraged to conduct a local search to locate other supplementary materials for use with this problem area. The items in this problem area are for reference or modification as instructors adapt these materials to their local situation.

#### CREDIT SOURCES:

These materials were developed through a funding agreement, R-33-13-D-0362-466, with the Illinois State Board of Education, Department of Adult, Vocational and Technical Education, Research and Development Section, 100 North First Street, Springfield, Illinois 62777. Opinions expressed in these materials do not reflect, nor should they be construed as policy or opinion of the State Board of Education or its staff.

The teacher's guide, student worksheets, transparency discussion guide, and test questions were developed by Al Zwilling, Department of Vocational and Technical Education, University of Illinois. Transparency masters were prepared by Vocational Agriculture Service, University of Illinois. Suggestions and guidance in the development of these materials were provided by the Rural Core Curriculum Field Test Teachers. This problem area was reviewed by the following vocational agriculture teachers:

Brian Cirks - Alexis High School  
Steve Myers - Lewistown High School  
Jack Stork - Jerseyville High School

## TEACHERS' GUIDE

- I. Unit: Agricultural mechanics
- II. Problem area: Adjusting and maintaining planting equipment
- III. Objectives: At the close of this problem area students will be able to:
  1. Calibrate a planter to the desired planting rate.
  2. Calibrate a drill to the desired seeding rate.
  3. List the recommended maintenance practices for the drill and planter.
  4. Calibrate fertilizer, herbicide, and insecticide attachments at the correct rate.
  5. Properly service and maintain the planter during planting season.
- IV. Suggested interest approaches:
  1. Ask students to explain how they maintain their planters and drills at home.
  2. Use the Competency Inventory to assess the students' present level of knowledge about planters and drills.
  3. Lead a group discussion on why accurate calibration is important.
  4. Bring an individual planter unit into the classroom, and have students experiment with adjustments.
  5. Ask students to list the various parts of a planter or drill from an overhead transparency.
- V. Anticipated problems and concerns:
  1. How do I adjust the planting rate on the planter?
  2. How do I calibrate the planter attachments?
  3. Are all planters calibrated the same way?
  4. What are the adjustments on a drill?
  5. How do I set the drill for fertilizer application?

6. What are the parts of the planter?
7. What are the parts of the drill?
8. How should planters and drills be maintained?
9. How should planters and drills be serviced before storing?

VI. Suggested learning activities and experiences:

1. List problems and concerns identified by class on the chalkboard.
2. Go over the Information Sheets included with this problem area for the students to gain general information about planters and drills.
3. Have students complete Worksheets 4 and 5 using references from the classroom, and those included with problem area.
4. Have students complete the corn planter and drill Worksheets 1, 2, and 3, using either an owner's manual for the planter, or bring a planter into the shop and have them answer the questions.
5. Use the Competency Inventory to introduce the students to the skills needed to enter the job market. Have students complete the Competency Inventory, rating themselves on how well they have mastered certain competencies.
6. Bring a planter into the shop. Show the students what parts need to be maintained. Show students how to adjust seeding rates and planting depths, and how to adjust the attachments.
7. Bring a grain drill into the shop. Show the students what parts of the drill need to be maintained. Show them how to set the seeding and fertilizing rates.
8. Use the selected transparencies and discussion guide to help the students better understand planters and drills.
9. Use selected test questions to evaluate the students' progress.
10. Take the students to the school plot, and have students make adjustments on the planter and drill. Have students adjust the depth of planting, and the rate of planting. Have students calibrate fertilizer and pesticide attachments.
11. Take the planter or drill back to the school shop, and have students prepare it for off season storage. Have the students clean the planter boxes or bin, or the seed bin on the drill. Have students lubricate all moving parts. Have students remove excess dust, and dirt from the equipment.

12. Have students prepare a bulletin board with the different types of planters. Have students volunteer to discuss the advantages, and disadvantages of the conventional planter, the plateless, plateless air planters, and minimum tillage planters.

VII. Application procedures:

1. Students should acquire knowledge in planter and drill maintenance that will be beneficial to them on the farm or in their employment.
2. Students should use these skills to improve the supplementary farm jobs section of their S.O.E. programs.

VIII. Evaluation:

1. Collect and evaluate students' worksheets.
2. Construct and administer a pencil and paper test, using some of the sample test questions included with this problem area.
3. The teacher could use the Competency Inventory as a guide to evaluate the number and quality of skills the student has learned from this problem area.

IX. References and aids:

1. Transparencies included with this problem area.
2. Information sheets included with this problem area.

Supplementary References:

1. Deere and Company, 1981 Fundamentals of Machine Operation, Planting.
2. Owner's manuals for planters and drills.

## COMPETENCY INVENTORY

### ADJUSTING AND MAINTAINING PLANTING EQUIPMENT

1. Student has no knowledge of competency.
2. Student has read about competency.
3. Student has seen competency performed.
4. Student has performed competency.
5. Student has performed competency without supervision.
6. Student does possess skill.
7. Student does not possess skill.

Competency	Circle One
1. Interpret planting charts on seed corn bag	1 2 3 4 5
2. Calculate actual seeding rate	1 2 3 4 5
3. Adjust planter or drill for recommended seeding rate	1 2 3 4 5
4. Calibrate fertilizer attachments	1 2 3 4 5
5. Calibrate insecticide and herbicide attachments	1 2 3 4 5
6. Adjust planting depth	1 2 3 4 5
7. Properly maintain planters and drills	1 2 3 4 5
8. Set row spacing	1 2 3 4 5
9. Set planter markers	1 2 3 4 5
10. Trouble shoot problems with planters and drills	1 2 3 4 5
11. Follow recommended safety practices when working with planters and drills	1 2 3 4 5
12.	
13.	
14.	
15. Describe the effects of row width and plant population	6 7
16. Identify parts of a planter and drill	6 7
17. List the parts of planters and drills that need to be maintained	6 7

These are competencies outlined in the National Ag Occupations Competency Study, for entry level positions of agricultural production.

Name \_\_\_\_\_ Date \_\_\_\_\_

## INFORMATION SHEET #1

### FUNCTIONS OF PLANTERS AND DRILLS

#### 1. OPENING A FURROW IN THE SOIL

The grain must be placed in moisture for the grain to germinate. The grain should be at an equal depth, regardless of the soil conditions. The furrow opener on planters and drills allows for both of these conditions to be met.

#### 2. METERING THE SEED

In order to obtain maximum yields, the seeds must be planted at specific rates. This is accomplished by use of metering devices on planters and drills, which regulates when seeds are put into the soil.

#### 3. PLACING THE SEED

Crop yields depend heavily upon depth of planting, and spacing between plants. If recommendations were not followed, yields would be reduced. This function is accomplished by the two previous functions. The furrow opener provides a uniform depth for the seeds, while the metering device allows for equal spacing between plants.

#### 4. COVERING THE SEED

The seed must be covered for protection against such factors as temperature, moisture and rodents. If the seeds were not covered, these factors and others would decrease the possibilities of the seeds germinating, and thus decreasing yields. This function is usually accomplished by the use of press wheels on planters, and by the chains or drags on drills.

#### 5. FIRING THE SEEDBED

Another function of the planter is accomplished by use of the press wheels and chains. This function is firming the seedbed. This reduces crust formation, and provides for excellent germinating conditions.



## INFORMATION SHEET #2

### TYPES OF PLANTERS

1. Row crop planters
2. Grain drills
3. Broadcast seeders
4. Specialized planters

1. Row-crop planters are classified by the crops planted and the planting method. They are sized according to the number of rows they will plant and the spacing between rows. These planters are different in frame type, planter drives, furrow openers, seed metering systems, seed placement systems, seed depth control systems and seed covering devices. Some of these planters include attachments for herbicides, insecticides, tillage, and monitoring.
2. Grain drills are used when solid planting is to occur. This means the rows are too close to permit cultivation or other cultural practices between them. Grain drills are usually used for crops such as soybeans, wheat, oats, barley, and grain sorghum; and grasses and legumes like bromegrass, fescue, timothy, alfalfa, and clover. There are three major types of grain drills. They are the end-wheel drill, press-wheel drill, and tilling seeder. Grain drills are usually sized according to the number of furrow openers, and the distance between openers. Drills differ in method of drive, seed metering, type of furrow openers, seed depth control, seed covering and firming, and various attachments.
3. Broadcast seeders have no actual planting devices. The seed is broadcast on top of the soil. It is very important that there be a good seedbed, and some method of covering the seed once it is broadcast. Seed distribution is usually less accurate than other methods listed. There are two general types of seeders. They are the centrifugal type and full-width-feed broadcaster.
4. Specialized planters are those which are required to plant specific crops. These include planters for potatoes and vegetables, and transplanters. They are only used for one specific purpose, and are all very different, depending on which crop they are planting. However, the same basic functions still apply.

## INFORMATION SHEET #3

### STORAGE PROCEDURES FOR PLANTERS

1. Inspect all parts for wear and breakage.
2. Empty and clean the fertilizer, herbicide, and insecticide boxes.
3. Remove and wash fertilizer parts to prevent severe corrosion from fertilizer residue.
4. Coat the furrow openers and knife or disk coverers with oil or grease to prevent rusting.
5. Paint any exposed metal surfaces to prevent rusting.
6. Lock the markers into transport position.
7. Block up the planter with the wheels off the ground in a building.
8. Wipe all fittings clean before lubricating.
9. Lubricate all bearings and moving parts.
10. Remove hydraulic cylinder from planter.

INFORMATION SHEET #4  
STORAGE PROCEDURES FOR DRILLS

1. Inspect all parts for wear and breakage.
2. Remove all seeds and fertilizer from the hoppers.
3. Remove and wash fertilizer parts to prevent severe corrosion from fertilizer residue.
4. Paint the hoppers where paint is chipped off.
5. Coat the inside of the fertilizer hopper with diesel fuel to prevent corrosion.
6. Clean furrow openers and coat them with oil or grease to prevent rusting.
7. Remove drill tubes, clean them and store them in the grain hopper until the next season.
8. Raise the drill and block it up so the tires do not touch the ground.
9. Wipe all fittings clean before lubricating.
10. Lubricate all bearings and moving parts.

STUDENT WORKSHEET #1  
PLANTER INFORMATION SHEET

Use either an owner's manual or an actual planter to complete this worksheet.

Mfg. Name \_\_\_\_\_ Model \_\_\_\_\_

Size \_\_\_\_\_ Conventional or No-Till \_\_\_\_\_

Planter

What row spacings are possible? \_\_\_\_\_

How is pressure on the press wheels adjusted? \_\_\_\_\_

\_\_\_\_\_

List special precautions for transporting? \_\_\_\_\_

Describe how to set the markers? \_\_\_\_\_

\_\_\_\_\_

Is this a plate, or plateless planter? \_\_\_\_\_

Planting Unit

What planting rates are possible? \_\_\_\_\_

How is depth of planting controlled? \_\_\_\_\_

\_\_\_\_\_

What is the capacity of the hoppers? \_\_\_\_\_

How are seed plates matched to the seed? \_\_\_\_\_

\_\_\_\_\_

How is the seeding rate adjusted? \_\_\_\_\_

\_\_\_\_\_

Fertilizer Attachment

How is the fertilizer attachment engaged? \_\_\_\_\_

\_\_\_\_\_

What care is needed for fertilizer attachments? \_\_\_\_\_

\_\_\_\_\_

What maintenance is needed on fertilizer attachments? \_\_\_\_\_  
\_\_\_\_\_  
\_\_\_\_\_

Where is fertilizer placed in relation to the seed? \_\_\_\_\_  
\_\_\_\_\_

What is the capacity of hoppers or tanks? \_\_\_\_\_  
\_\_\_\_\_

How are the fertilizer attachments calibrated? \_\_\_\_\_  
\_\_\_\_\_

### Insecticide and Herbicide Attachments

What care is needed on these attachments? \_\_\_\_\_  
\_\_\_\_\_  
\_\_\_\_\_

How are these attachments calibrated? \_\_\_\_\_  
\_\_\_\_\_

### Planter Servicing

Why is it important to have proper tire inflation? \_\_\_\_\_  
\_\_\_\_\_

What parts of the planter should be lubricated daily? \_\_\_\_\_  
\_\_\_\_\_

How should the planter be prepared for end of season storage? \_\_\_\_\_  
\_\_\_\_\_  
\_\_\_\_\_  
\_\_\_\_\_

STUDENT WORKSHEET #2  
GRAIN DRILL INFORMATION SHEET

Use either an owner's manual or an actual grain drill to complete this worksheet.

Mfg. Name \_\_\_\_\_ Model \_\_\_\_\_ Size \_\_\_\_\_

What is the capacity of the seed tank? \_\_\_\_\_  
\_\_\_\_\_

What is the capacity of the fertilizer tank? \_\_\_\_\_  
\_\_\_\_\_

How is the seed covered with soil by this drill? \_\_\_\_\_  
\_\_\_\_\_

How do you adjust the seeding rate? \_\_\_\_\_  
\_\_\_\_\_

How do you adjust the fertilization rate? \_\_\_\_\_  
\_\_\_\_\_

Why is it important that the drill be at a specific drawbar height? \_\_\_\_\_  
\_\_\_\_\_

What parts of the drill should be lubricated daily? \_\_\_\_\_  
\_\_\_\_\_

What maintenance activities should be employed to keep the drill in good condition? \_\_\_\_\_  
\_\_\_\_\_

How should the planter be prepared for off season storage? \_\_\_\_\_  
\_\_\_\_\_

STUDENT WORKSHEET #3

PLANTER ADJUSTMENTS

ADJUSTMENT

HOW ADJUSTMENT IS MADE

---

Rate of planting

---

Depth of planting

---

Fertilizer rate adjustment

---

Herbicide and Insecticide  
rates adjustments

---

Row spacing

---

Marker length

---

Planting speed

---

155

158

111-H-3-16

## STUDENT WORKSHEET #4 PLANTERS

Identify the main parts of the planter illustrated.

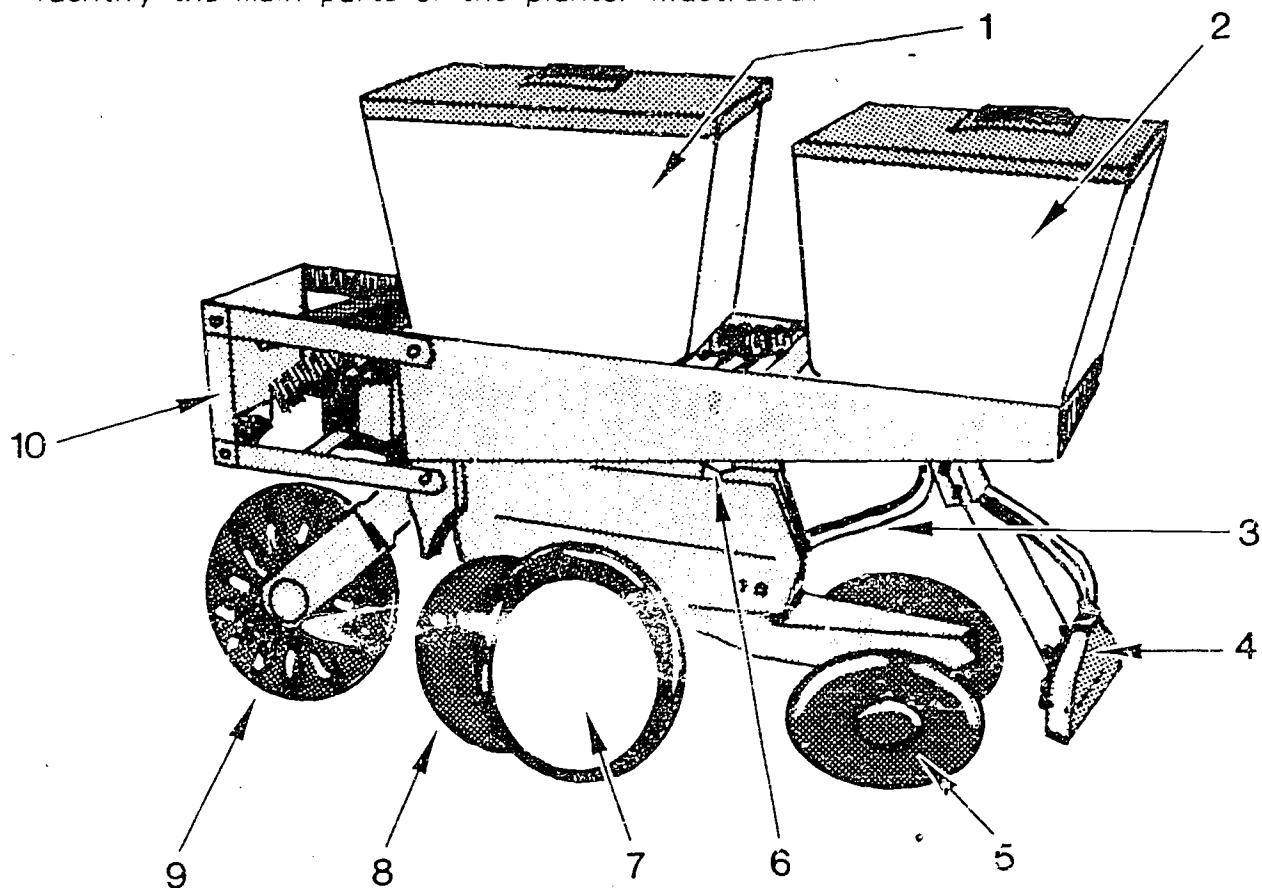

1. \_\_\_\_\_
2. \_\_\_\_\_
3. \_\_\_\_\_
4. \_\_\_\_\_
5. \_\_\_\_\_

6. \_\_\_\_\_
7. \_\_\_\_\_
8. \_\_\_\_\_
9. \_\_\_\_\_
10. \_\_\_\_\_

Questions:

1. What are the five functions of a planter?
  - A. \_\_\_\_\_
  - B. \_\_\_\_\_
  - C. \_\_\_\_\_
  - D. \_\_\_\_\_
  - E. \_\_\_\_\_



2. What are the classifications of row-crop planters?  
A. \_\_\_\_\_  
B. \_\_\_\_\_
3. How are row-crop planters sized?  
A. \_\_\_\_\_  
B. \_\_\_\_\_
4. What are four types of seed metering devices?  
A. \_\_\_\_\_  
B. \_\_\_\_\_  
C. \_\_\_\_\_  
D. \_\_\_\_\_
5. What are four types of furrow openers?  
A. \_\_\_\_\_  
B. \_\_\_\_\_  
C. \_\_\_\_\_  
D. \_\_\_\_\_
6. What are four types of seed coverers?  
A. \_\_\_\_\_  
B. \_\_\_\_\_  
C. \_\_\_\_\_  
D. \_\_\_\_\_
7. What are four types of seed placement mechanisms?  
A. \_\_\_\_\_  
B. \_\_\_\_\_  
C. \_\_\_\_\_  
D. \_\_\_\_\_
8. Why is row width important when planting crops? \_\_\_\_\_  
\_\_\_\_\_  
\_\_\_\_\_
9. List five storage procedures for planters.  
A. \_\_\_\_\_  
B. \_\_\_\_\_  
C. \_\_\_\_\_  
D. \_\_\_\_\_  
E. \_\_\_\_\_
10. List two adjustments on the planter that must be made in the field?  
A. \_\_\_\_\_  
B. \_\_\_\_\_

Identify the main parts of the plateless air planter

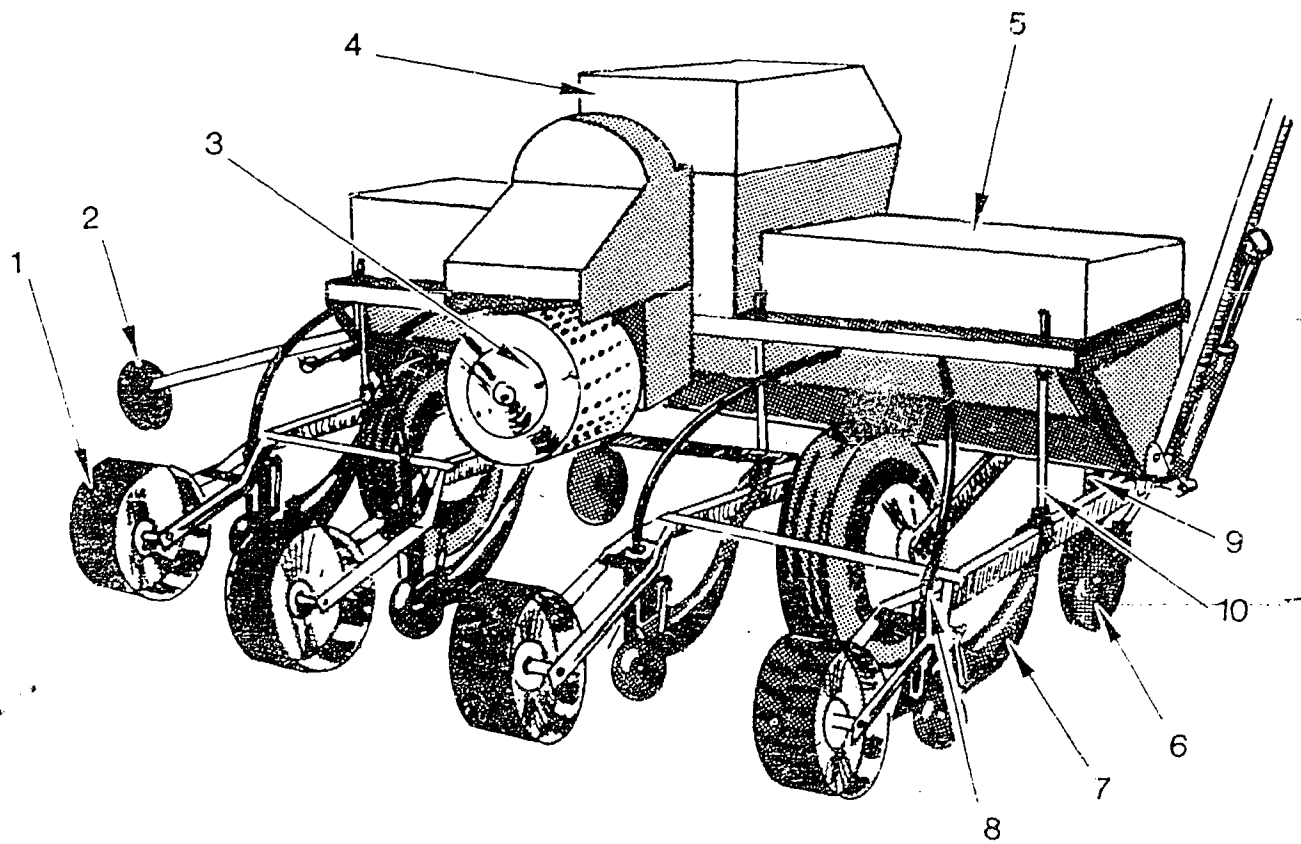

- 1. \_\_\_\_\_
- 2. \_\_\_\_\_
- 3. \_\_\_\_\_
- 4. \_\_\_\_\_
- 5. \_\_\_\_\_

- 6. \_\_\_\_\_
- 7. \_\_\_\_\_
- 8. \_\_\_\_\_
- 9. \_\_\_\_\_
- 10. \_\_\_\_\_

STUDENT WORKSHEET #5

GRAIN DRILLS

Identify the main parts of the grain drill illustrated.

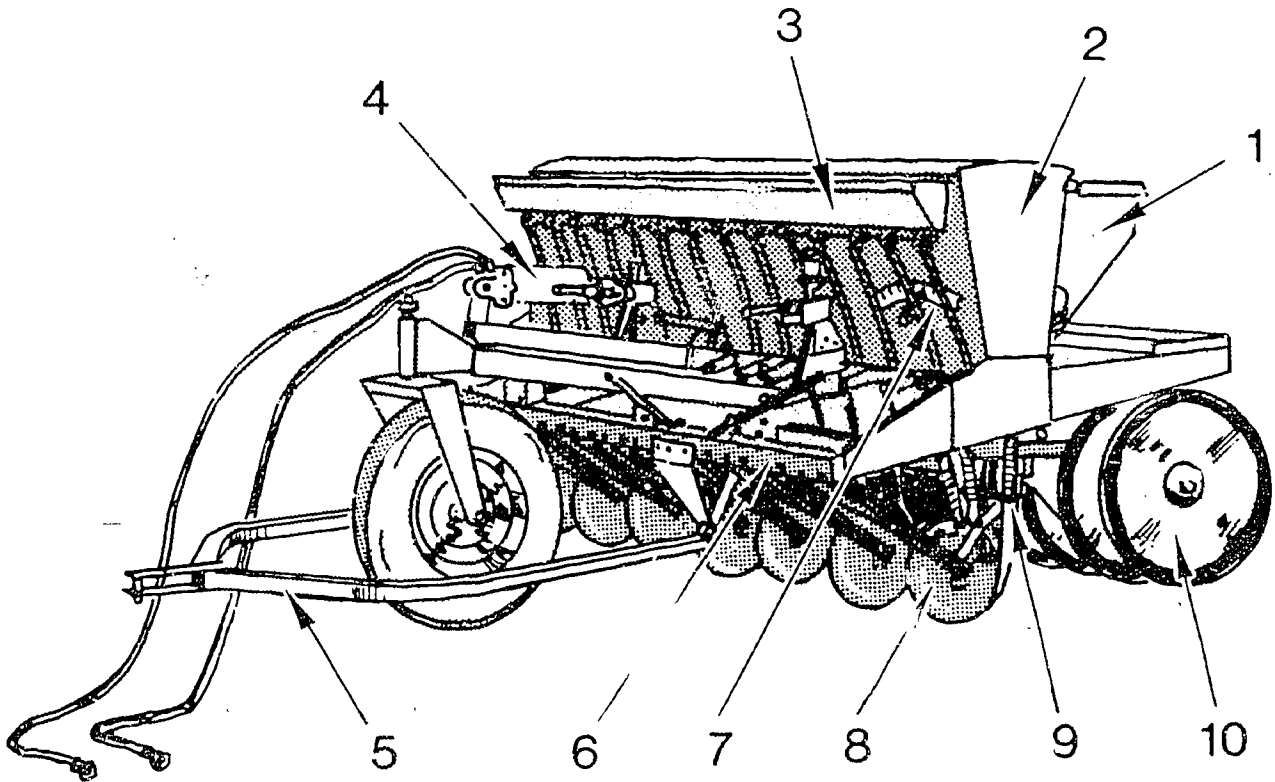

- 1. \_\_\_\_\_
- 2. \_\_\_\_\_
- 3. \_\_\_\_\_
- 4. \_\_\_\_\_
- 5. \_\_\_\_\_

- 6. \_\_\_\_\_
- 7. \_\_\_\_\_
- 8. \_\_\_\_\_
- 9. \_\_\_\_\_
- 10. \_\_\_\_\_

Questions:

- 1. What are two different methods of covering the seed with a grain drill?
  - A. \_\_\_\_\_
  - B. \_\_\_\_\_

2. What are two different types of feedcups used on drills?  
A. \_\_\_\_\_  
B. \_\_\_\_\_
3. What are two types of furrow openers used on grain drills?  
A. \_\_\_\_\_  
B. \_\_\_\_\_
4. What are five functions of a grain drill?  
A. \_\_\_\_\_  
B. \_\_\_\_\_  
C. \_\_\_\_\_  
D. \_\_\_\_\_  
E. \_\_\_\_\_
5. List five storage procedures for storing grain drills.  
A. \_\_\_\_\_  
B. \_\_\_\_\_  
C. \_\_\_\_\_  
D. \_\_\_\_\_  
E. \_\_\_\_\_

## JOB SHEET #1

### ADJUSTING PLANTERS FOR CORN AND SOYBEANS

#### OBJECTIVES:

1. To be able to properly set a planter for planting corn and soybeans.
2. To be able to adjust the planter for corn and soybeans.

#### MATERIALS:

1. A planter and tractor
2. Seed corn
3. Seed soybeans
4. Properly prepared seed bed for planting
5. Operator's manual

#### PROCEDURES:

1. Take students to the plot where tractor and planter are located.
2. Give the students the recommended planting rate for corn.
3. Have students adjust the planter for the given population.
4. Give students recommended planting depth.
5. Have students adjust to recommended planting depth.
6. Have students decide on the speed of the tractor.
7. Have students check periodically to make sure adjustments are correct.
8. Repeat the procedure only this time use soybeans. Make sure students make all the necessary changes in the planter when switching from corn to soybeans.

#### OBSERVATIONS:

Have students note the differences for planting corn and soybeans.

#### APPLICATION:

How could you or your S.O.E.P. benefit from this activity?

## JOB SHEET #2

### ADJUSTING DRILLS FOR SOYBEANS AND SMALL GRAINS

#### OBJECTIVES:

1. To be able to properly set a grain drill for sowing small grains and soybeans.
2. To be able to adjust a grain drill for sowing small grains and soybeans.

#### MATERIALS:

1. A seed drill and tractor
2. Wheat or oats
3. Soybeans
4. Properly prepared seedbed for planting wheat. This would be done in the fall, or with a properly prepared seedbed for oats in the spring. A seedbed for sowing soybeans is also needed.
5. Operator's manual

#### PROCEDURES:

1. Have tractor and drill at the site of the prepared seedbed.
2. Have students set the drill for sowing oats with recommendations given by the teacher.
3. Have student begin sowing, then have them check to see if they are sowing the recommended amount at the recommended depth.
4. Have students set drill to plant soybeans.
5. Have students adjust drill for the recommended rates for soybeans.
6. Have students periodically check on the adjustments.

#### OBSERVATIONS.

Have students describe the differences between setting the drill for oats and setting it for soybeans.

#### APPLICATION:

Ask students how this activity could improve their S.O.E.P.'s, and their planting skills.

## JOB SHEET #3

### PREPARING PLANTERS AND DRILLS FOR STORAGE

#### OBJECTIVES:

1. To be able to clean and lubricate a planter or drill for storage.
2. To be able to recognize any repairs that need to be done, before the equipment is used again.

#### MATERIALS:

1. Planter or drill
2. Set of common tools
3. Black paint or used oil
4. Paint brush, wire brush and putty knife
5. Operator's manual

#### PROCEDURES:

1. Remove chaff, clean, lubricate, and replace them.
2. Remove fertilizer, pesticide, and seed from boxes, and clean the boxes, bins, and grain tubes.
3. Lubricate all necessary parts.
4. Clean furrow openers or shoes, and coat them with black paint or oil to reduce rusting.
5. Check all parts to make sure all are in working condition. Check for wear. Replace or repair worn and broken parts.

#### OBSERVATIONS:

Why is it wiser to repair a planter or drill before putting it in storage, rather than when removing it from storage?

#### APPLICATION:

How could this exercise help you or your home farm, or with your S.O.E.P.?

JOB SHEET #4  
CHANGING ROW SPACINGS

OBJECTIVES:

1. To make students aware of some of the adjustments on planters.
2. To allow students to complete an actual adjustment, by setting row spacings.
3. To make students aware of how different row spacings affect yields.

MATERIALS:

1. Planter
2. Set of wrenches and tools
3. Operator's manual

PROCEDURES:

1. Lower the planter to the ground.
2. Loosen the mounting bolts.
3. Move the planting units to the desired width.
4. Adjust the middle units so that each is one-half the distance of the row spacing from the center.
5. Adjust the other units according to the row width, and retighten mounting bolts.
6. Recheck to make sure the row spacings are correct.
7. Adjust the spacing of the fertilizer furrow opener, so that it is about 2 inches away from the seed.

QUESTIONS:

1. What are the most common row spacings for corn? Soybeans?
2. What things must be done to assure accuracy?
3. Why must the fertilizer openers be moved?

OBSERVATIONS:

1. What is the most difficult part of this procedure?
2. Why is it important that the row spacings be accurate?

APPLICATION:

Discuss how this ability can be used to improve the students' S.O.E.P.'s.



TEACHER'S KEY  
STUDENT WORKSHEET #4  
PLANTERS

Identify the main parts of the planter illustrated.

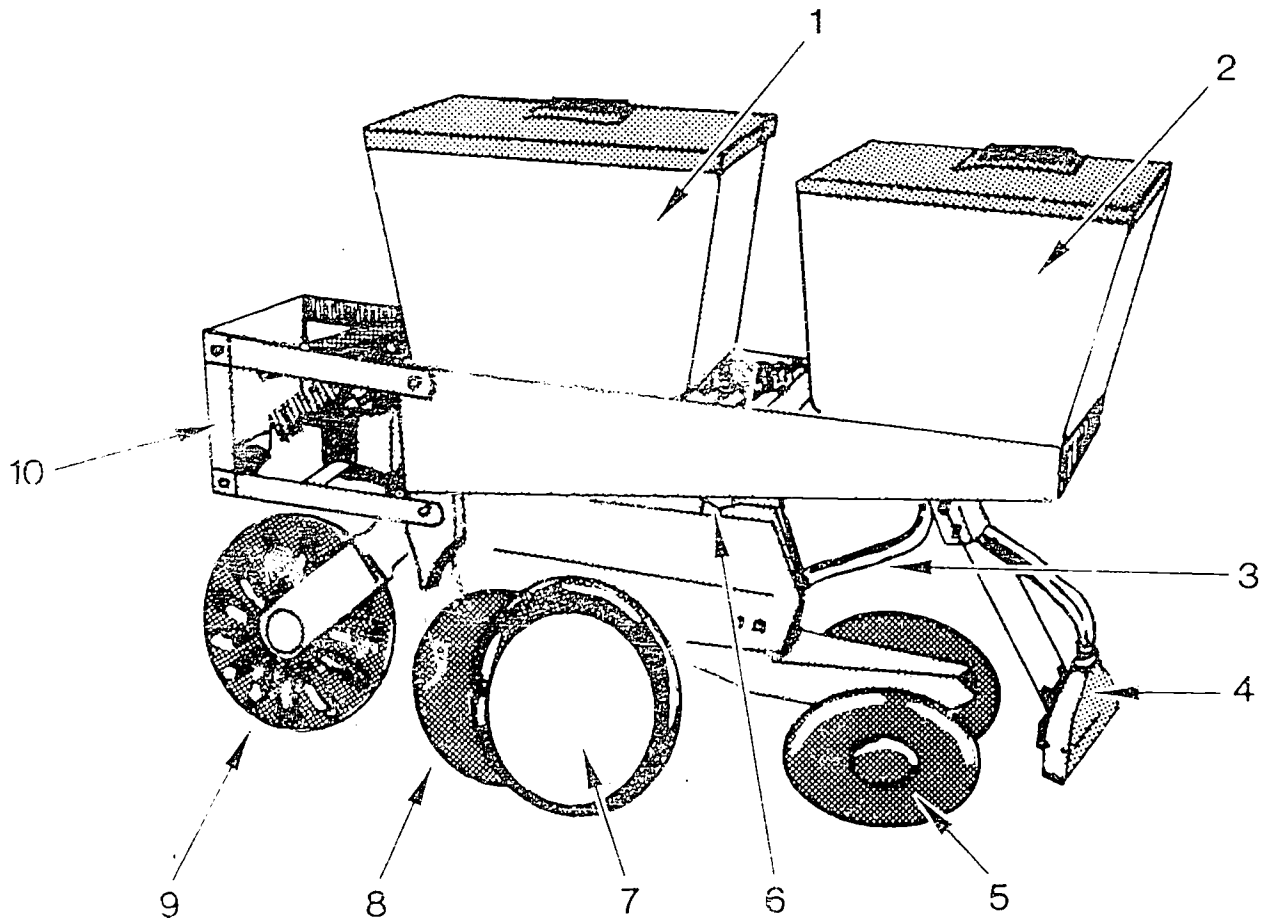

- |                                    |                     |
|------------------------------------|---------------------|
| 1. Seed Hopper                     | 6. Depth Adjustment |
| 2. Herbicide or Insecticide Hopper | 7. Gauge Wheels     |
| 3. Insecticide Tube                | 8. Furrow Openers   |
| 4. Herbicide Diffuser              | 9. Coulter          |
| 5. Seed Firming Wheels             | 10. Frame           |

Questions:

1. What are the five functions of a planter?
  - A. Open the soil
  - B. Meter the seeds
  - C. Place the seeds
  - D. Cover the seeds
  - E. Firm soil around the seeds

2. What are the classifications of row-crop planters?
  - A. Crops planted
  - B. Planting method
  
3. How are row-crop planters sized?
  - A. Number of rows they will plant
  - B. Spacing between rows
  
4. What are four types of seed metering devices?
  - A. Seed plate
  - B. Finger-pickup
  - C. Air devices
  - D. Volume devices
  
5. What are four types of furrow openers?
  - A. Double-disk
  - B. Runner
  - C. Combination double-disk and runner
  - D. Snovel
  
6. What are four types of seed coverers?
  - A. Shoes
  - B. Knife
  - C. Disk
  - D. Chain
  
7. What are four types of seed placement mechanisms?
  - A. Gravity-drop tube
  - B. Conveyer-belt drop
  - C. Rotary-valve drop
  - D. Air drop
  
8. Why is row width important when planting crops? When plants are too close, there is too much competition for nutrients and light, and plants do not do well.
  
9. List five storage procedures for planters.
  - A. (May use any from those listed on the transparency)
  - B. \_\_\_\_\_
  - C. \_\_\_\_\_
  - D. \_\_\_\_\_
  - E. \_\_\_\_\_
  
10. List two adjustments on the planter that must be made in the field?
  - A. Field calibration
  - B. Planting depth

Identify the main parts of the plateless air planter.

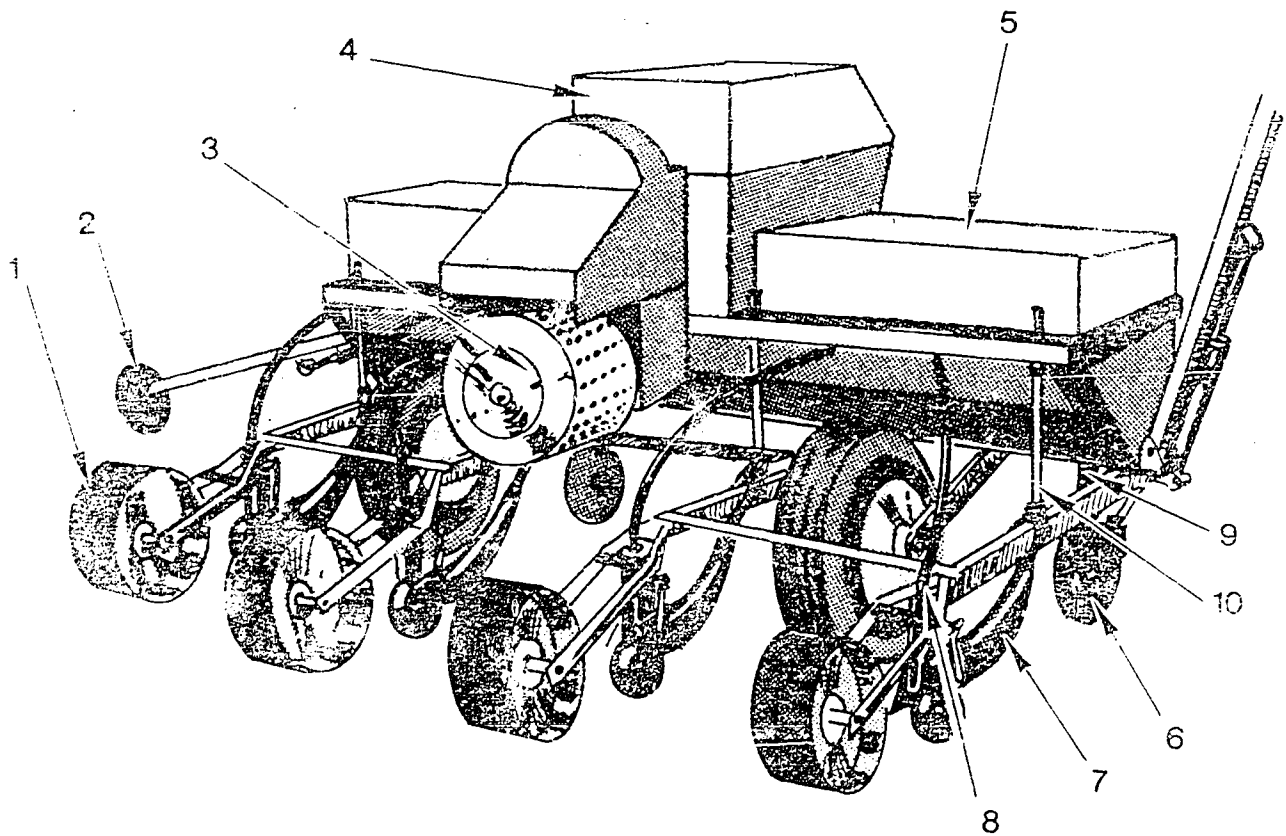

1. Press wheel
2. Marker
3. Seed drum
4. Seed hopper
5. Fertilizer hopper

6. Furrow opener
7. Runner
8. Seed tubes
9. Fertilizer tubes
10. Depth adjustment

TEACHER'S KEY  
STUDENT WORKSHEET  
GRAIN DRILLS

Identify the main parts of the grain drill illustrated.

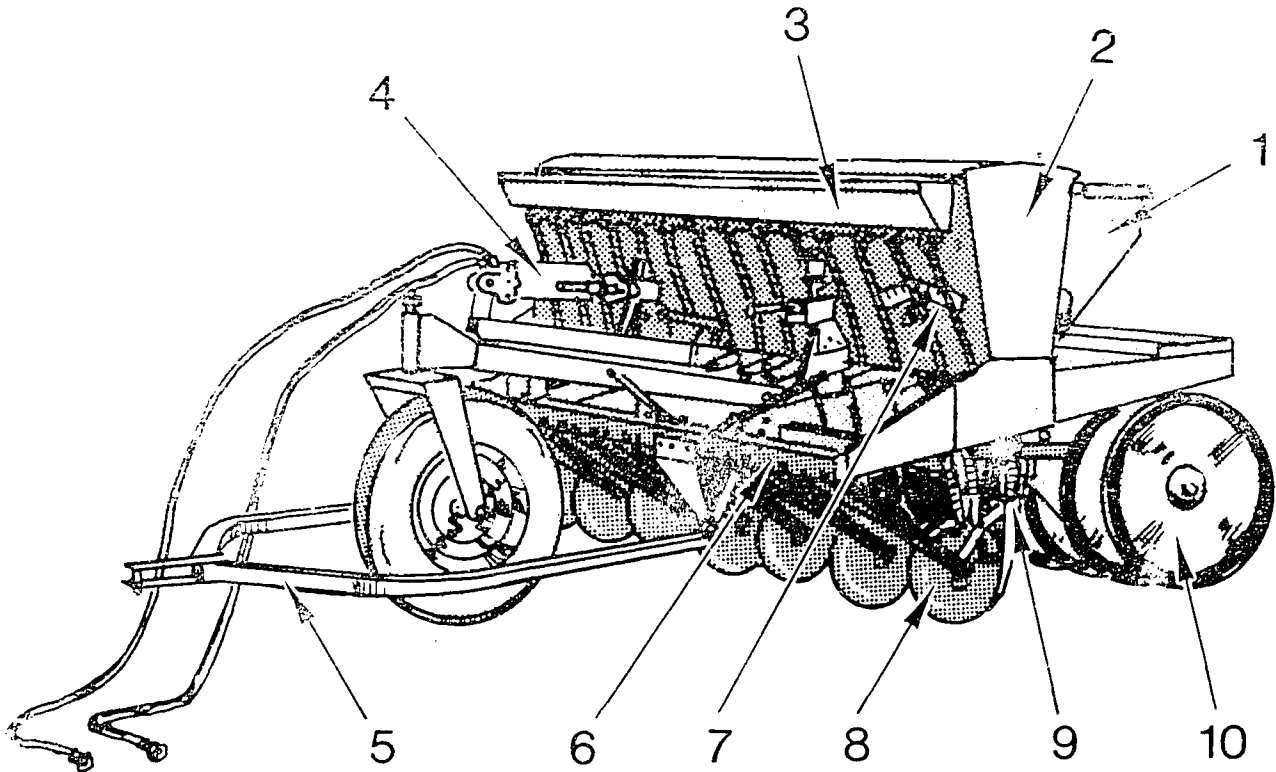

- |                       |                          |
|-----------------------|--------------------------|
| 1. Seed hopper        | 6. Frame                 |
| 2. Fertilizer hopper  | 7. Seed metering control |
| 3. Grass seed hopper  | 8. Furrow openers        |
| 4. Hydraulic cylinder | 9. Seed tube             |
| 5. Hitch              | 10. Press wheel          |

Questions:

1. What are two different methods of covering the seed with a grain drill?
  - A. Press wheel
  - B. Drag chain

2. What are two different types of feedcups used on drills?
  - A. Fluted
  - B. Double run
  
3. What are two types of furrow openers used on grain drills?
  - A. Disk type
  - B. Shovel type
  
4. What are five functions of a grain drill?
  - A. Open the soil
  - B. Meter the seed
  - C. Place the seed
  - D. Cover the seed
  - E. Firm soil around seed
  
5. List five storage procedures for storing grain drills.
  - A. (May use any for those listed on the transparency.)
  - B. \_\_\_\_\_
  - C. \_\_\_\_\_
  - D. \_\_\_\_\_
  - E. \_\_\_\_\_

# Parts of a Planting Unit

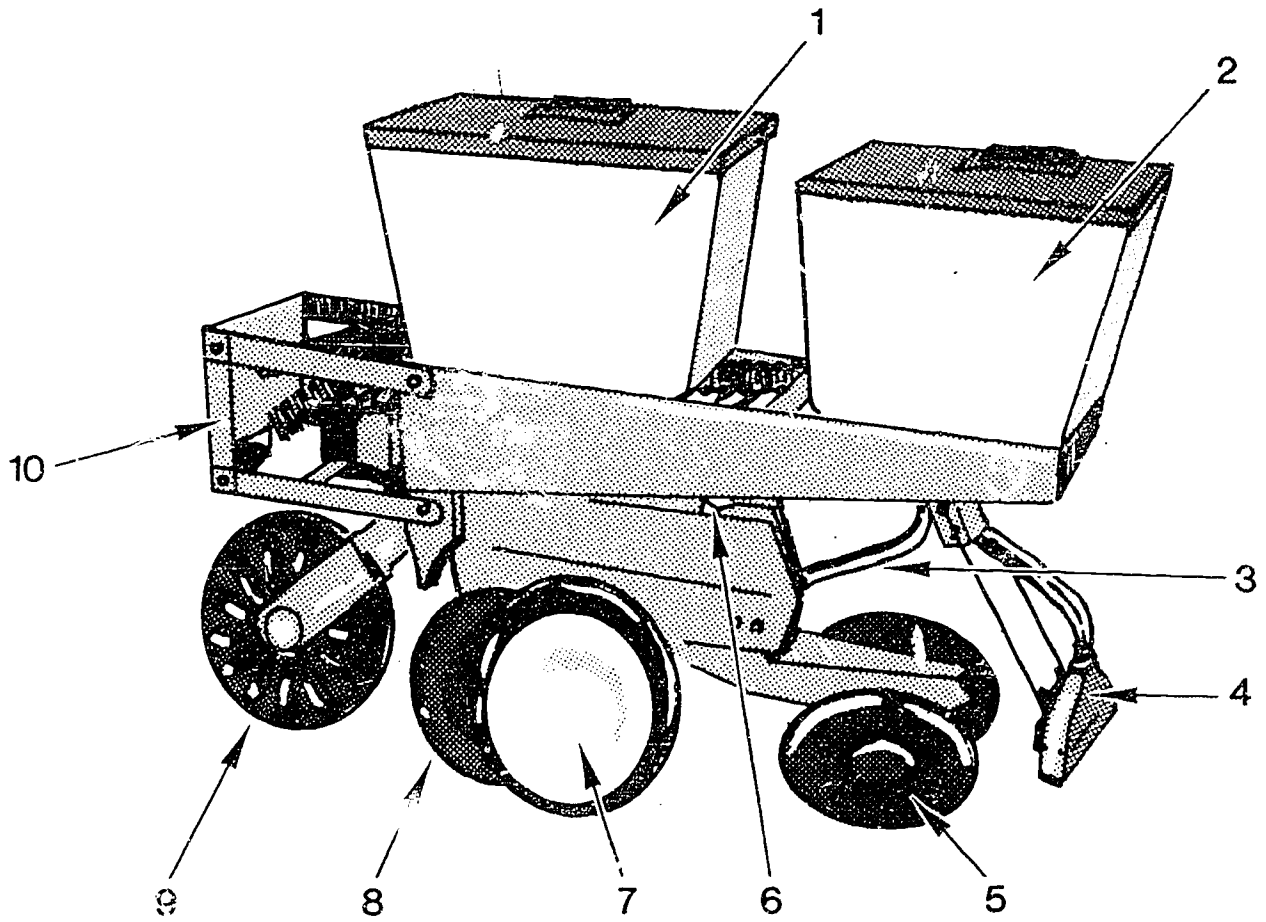

# Parts of a Plateless Air Planter

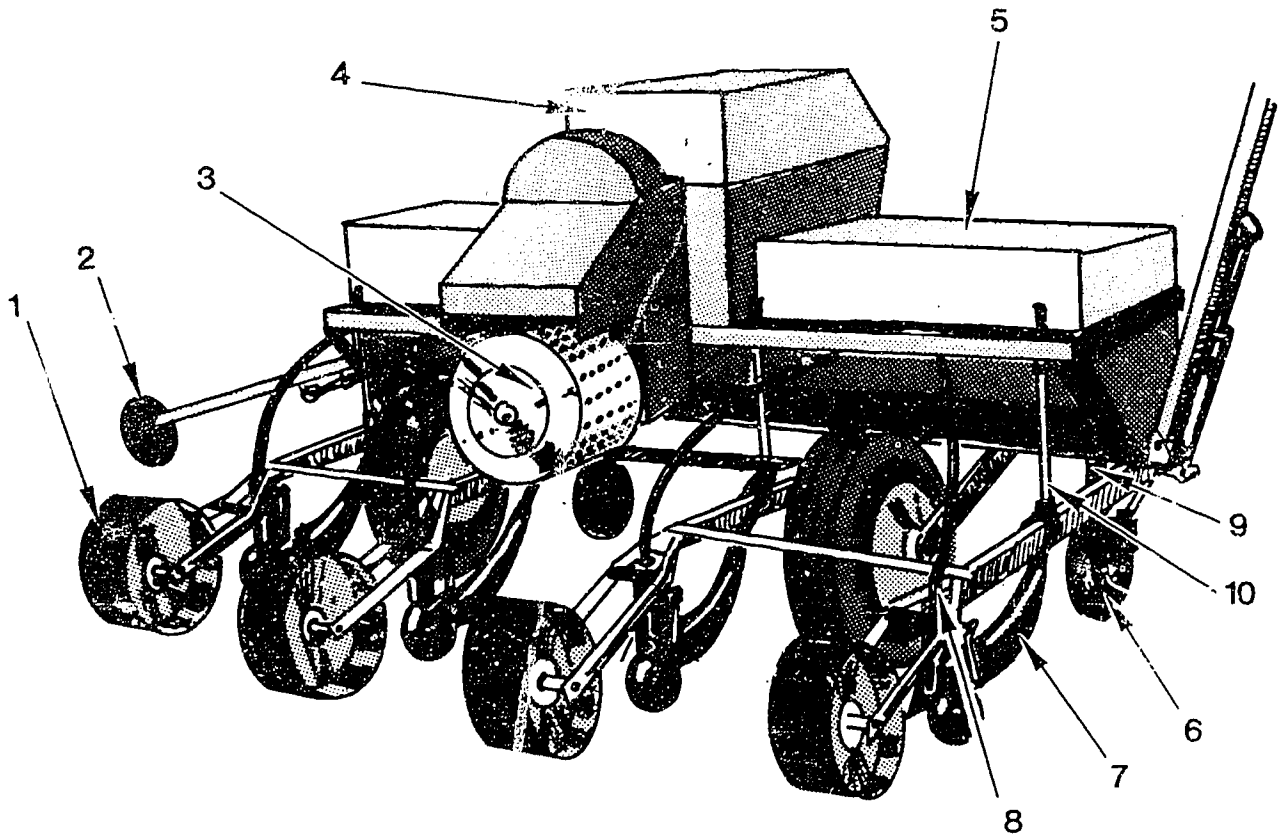

172

III-H-3-34

# Two Planter Firming Methods

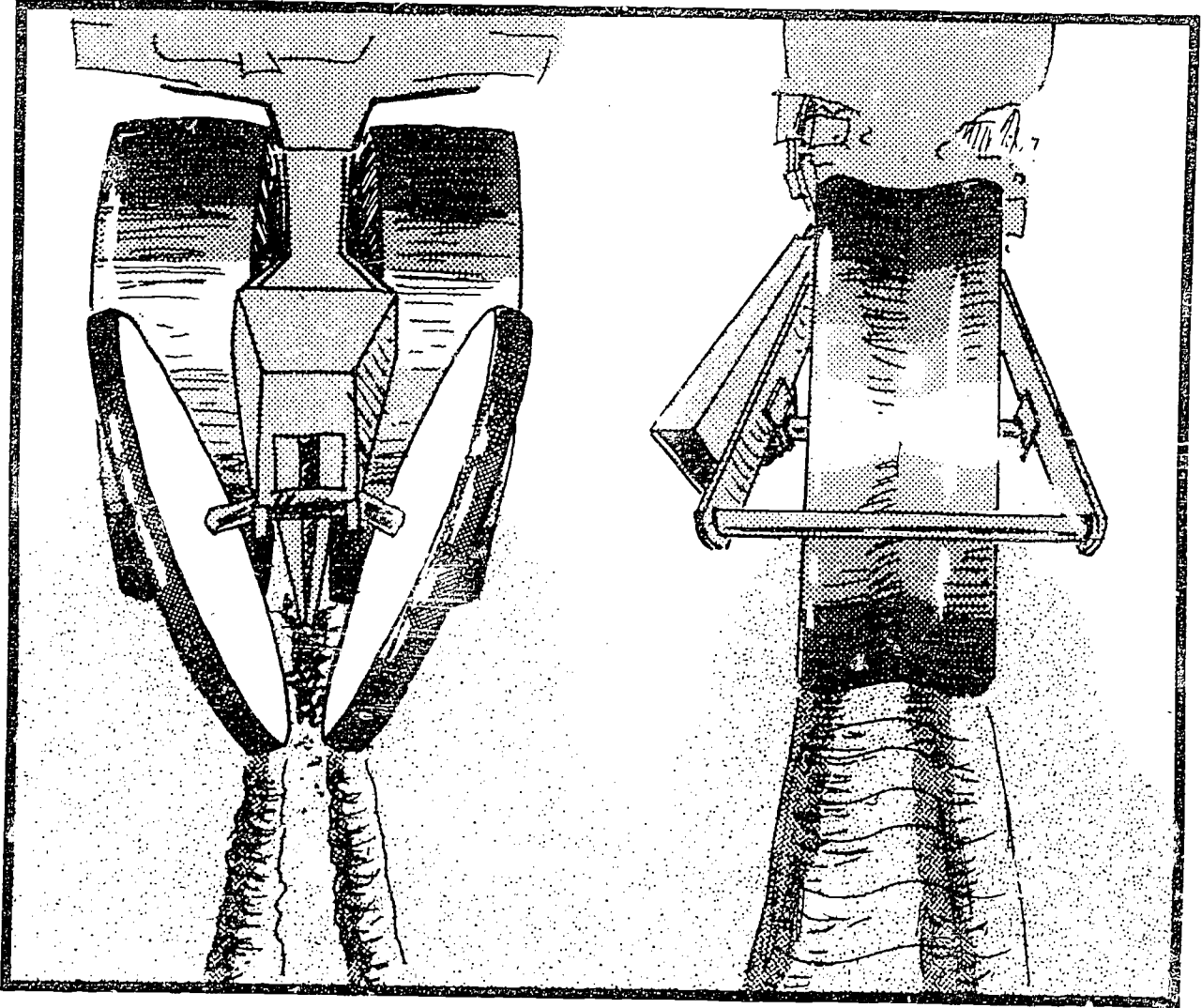



# Types of Metering Devices

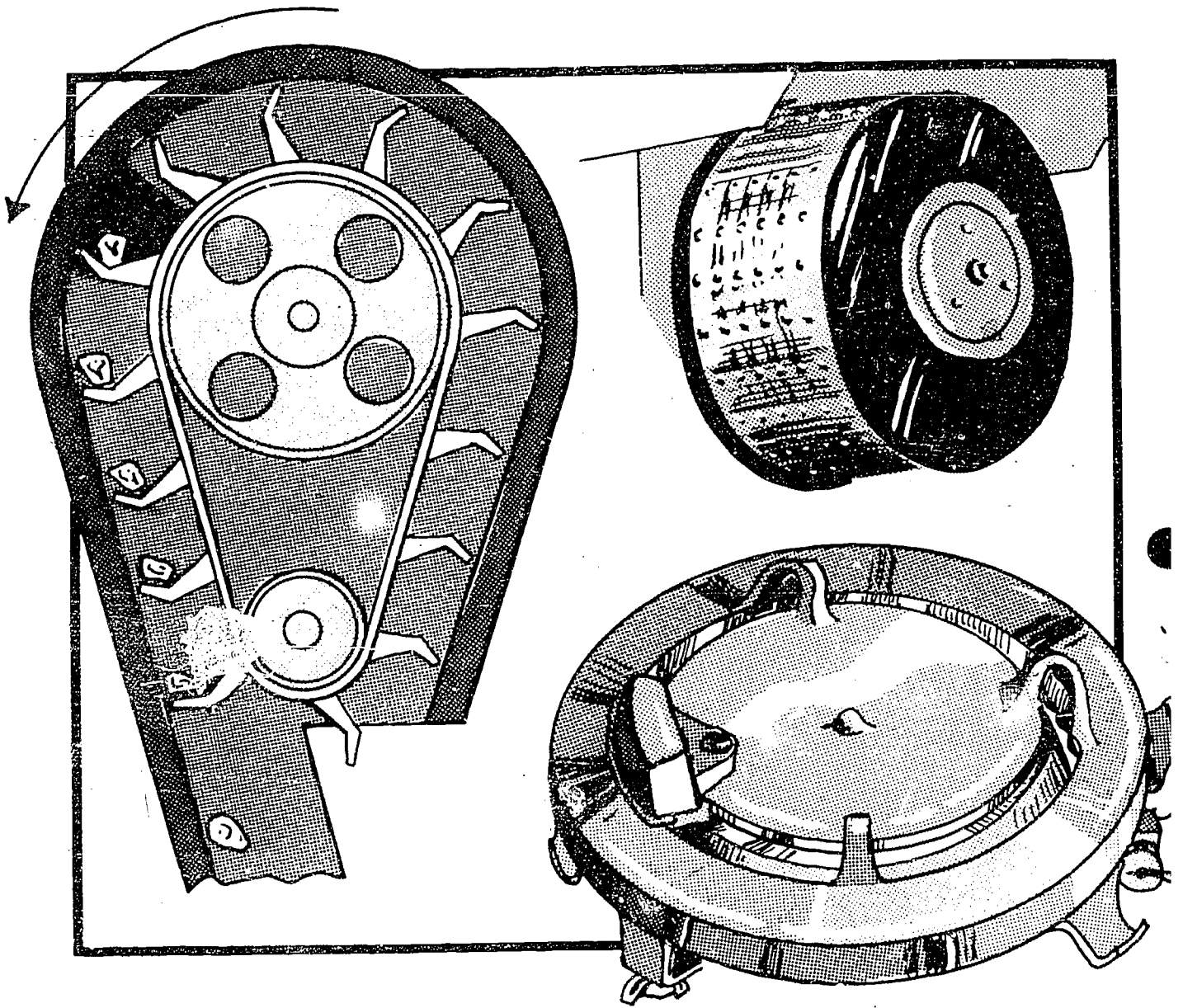

# Planter Depth Adjustment

A.

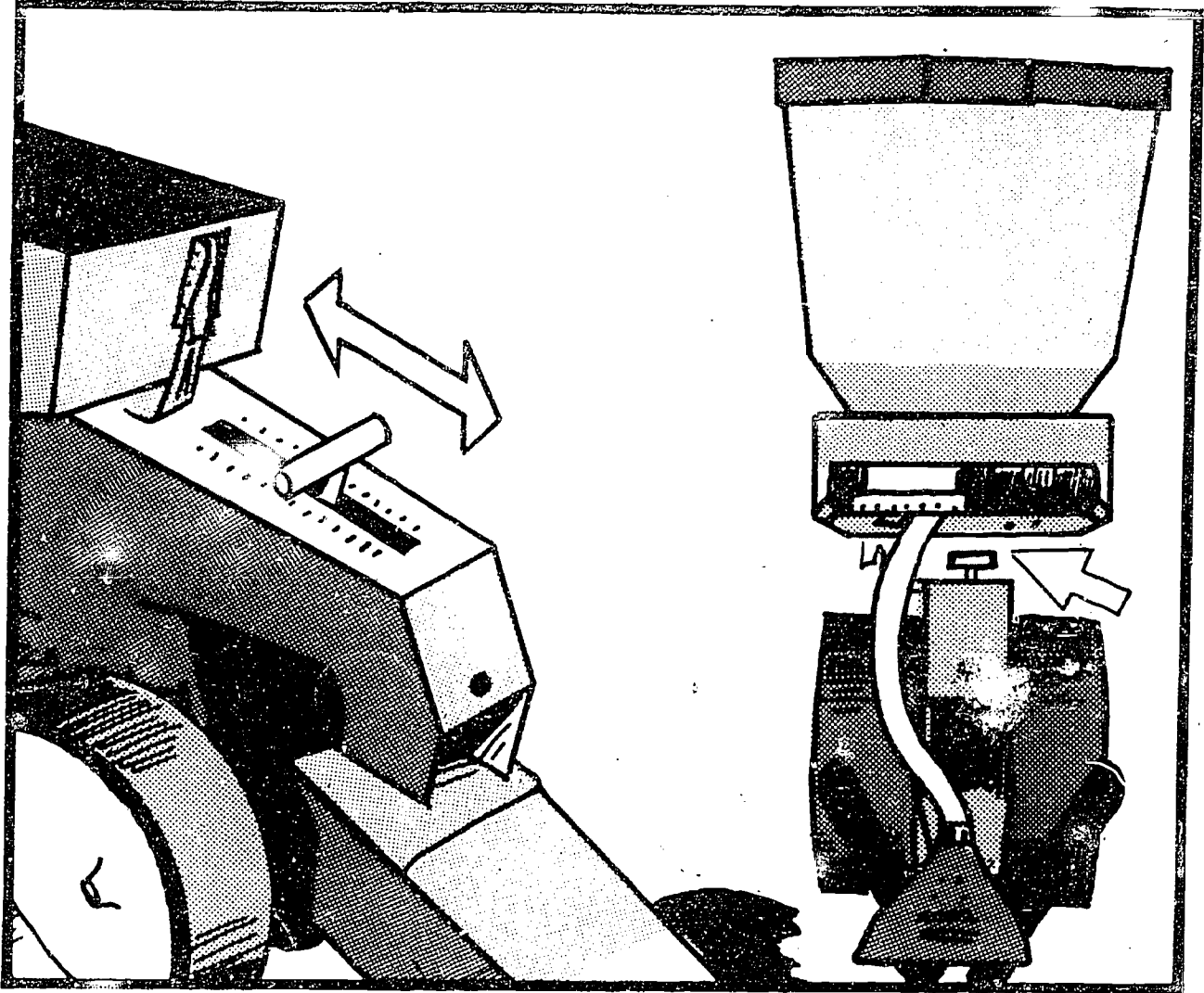

# Planter Depth Adjustment

B.

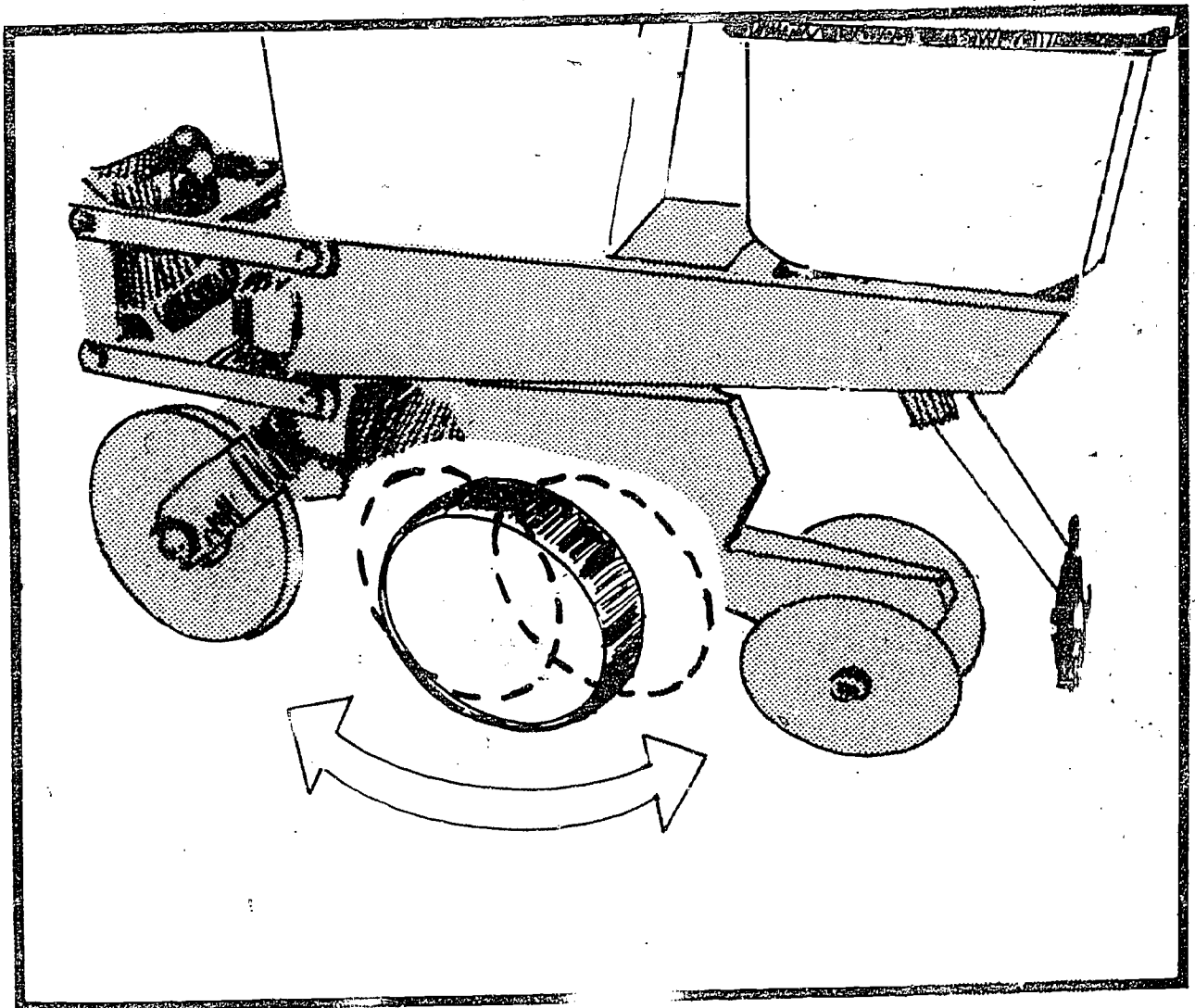

# Planter Depth Adjustment

C.

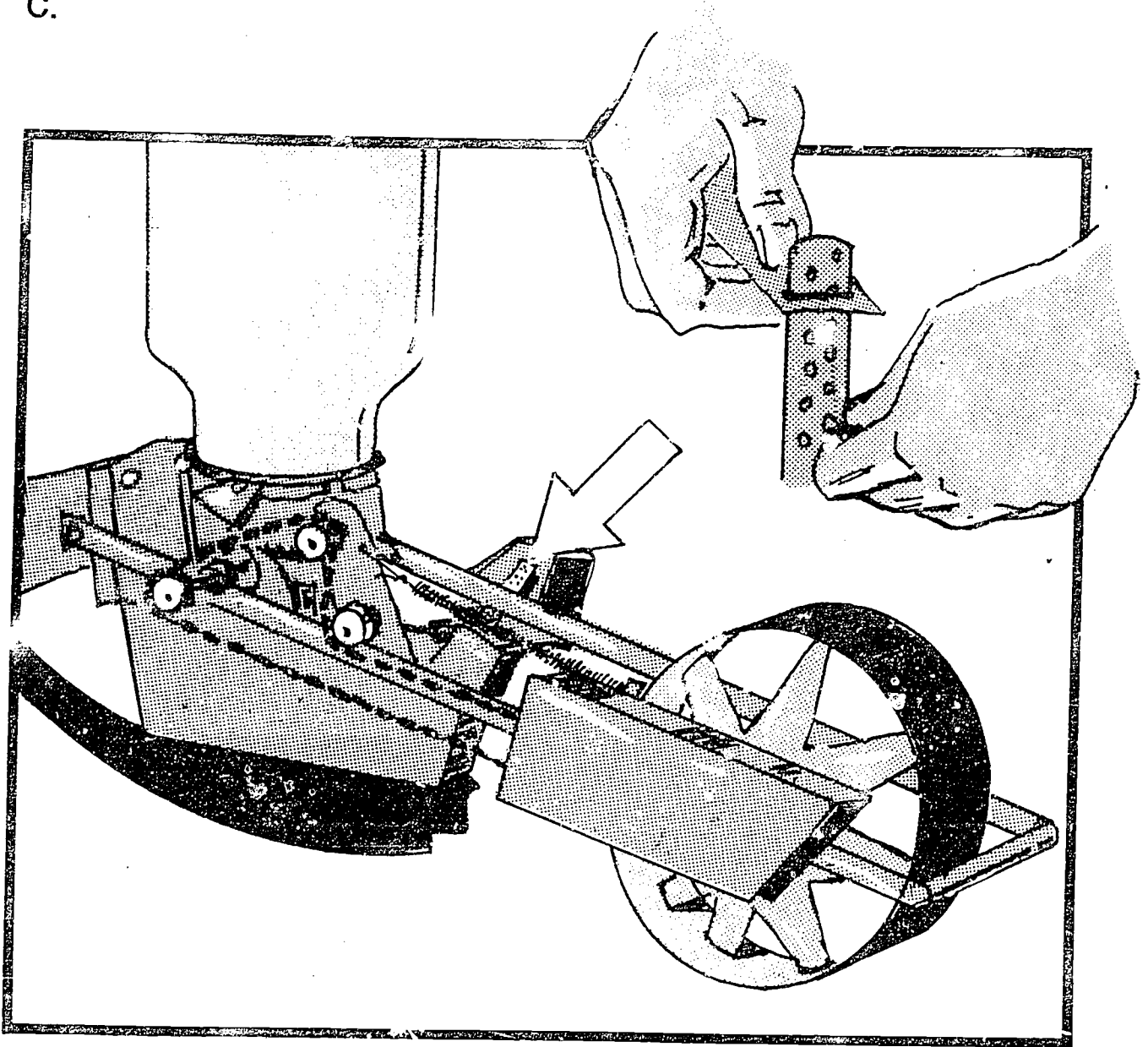

# Calibrating Insecticide and Herbicide Attachments

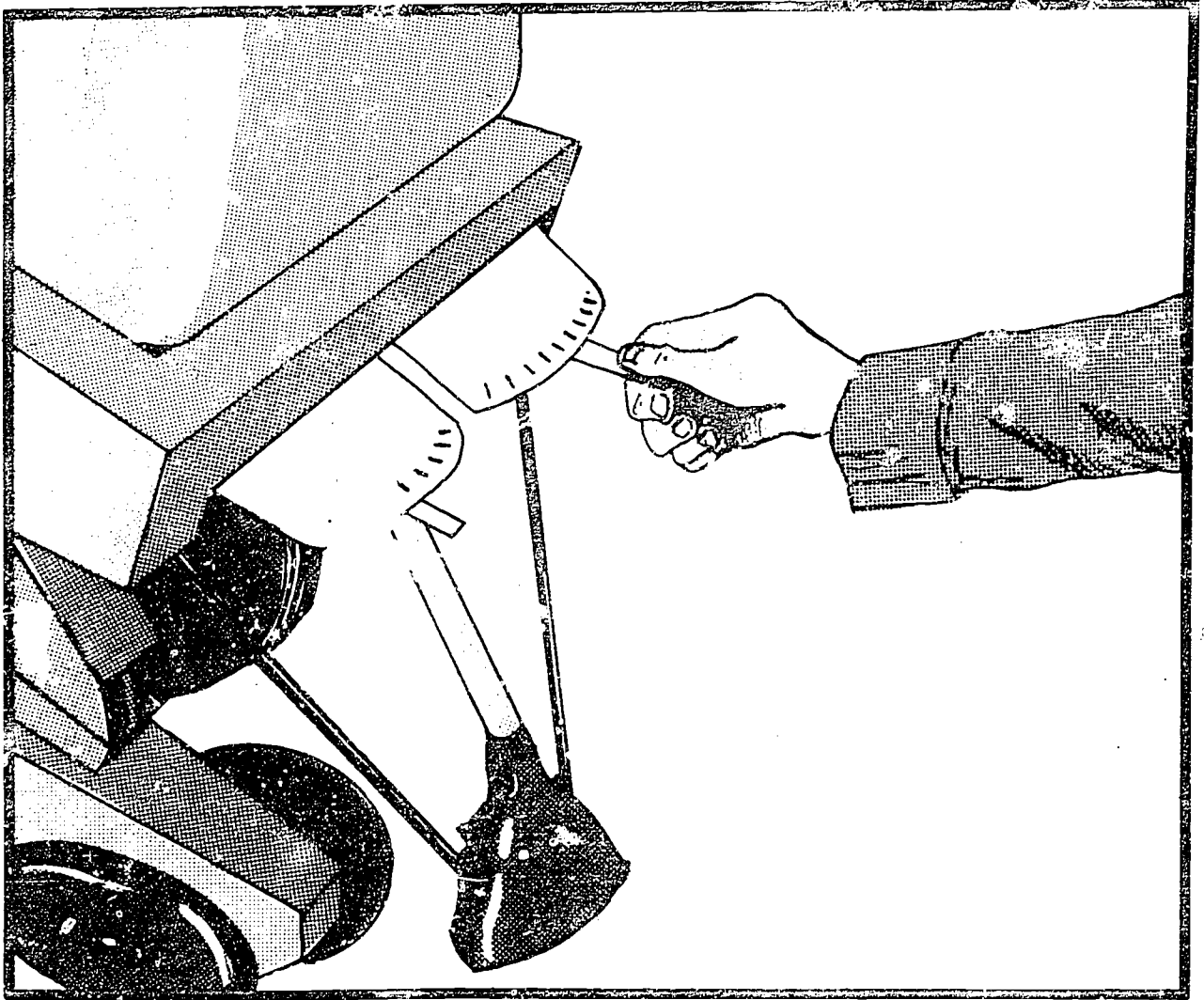

173

III-H-3-40

# Parts of a Grain Drill

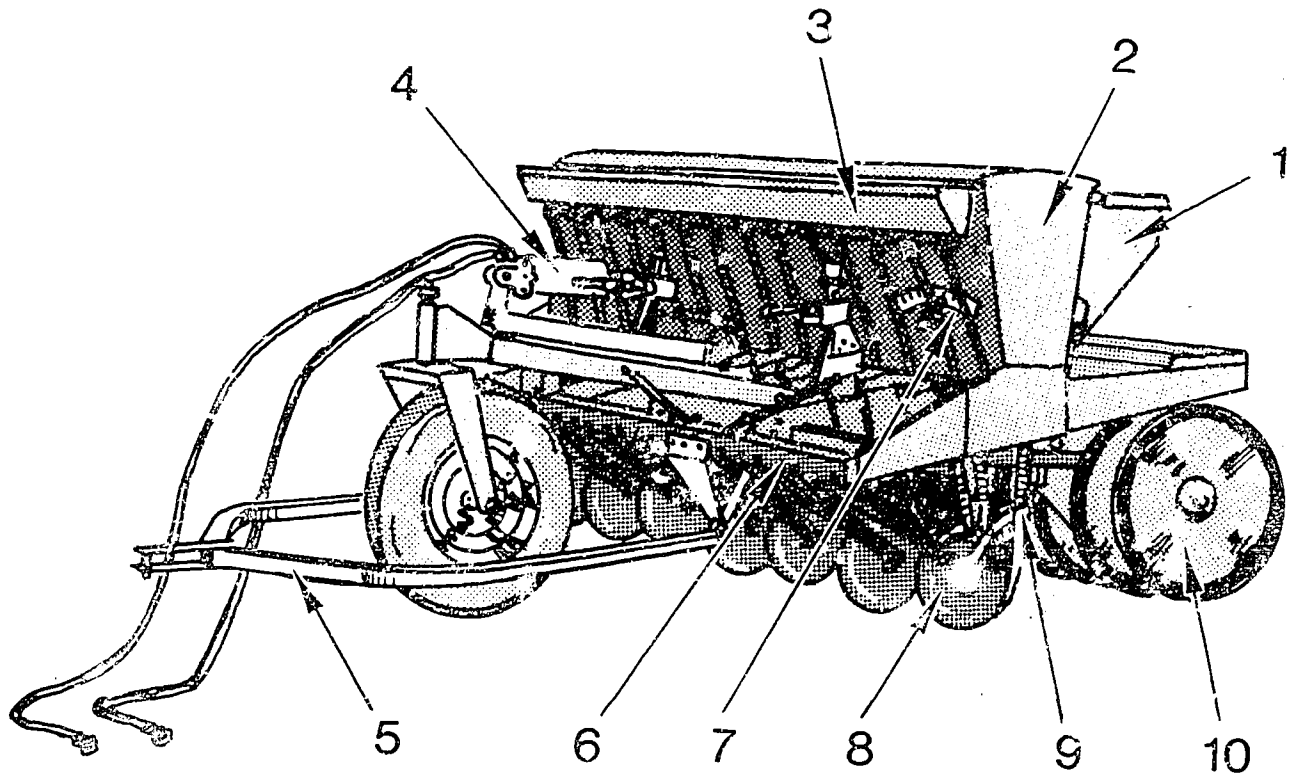

17J

III-H-3-41



# Methods of Covering Seeds on Drills

A.

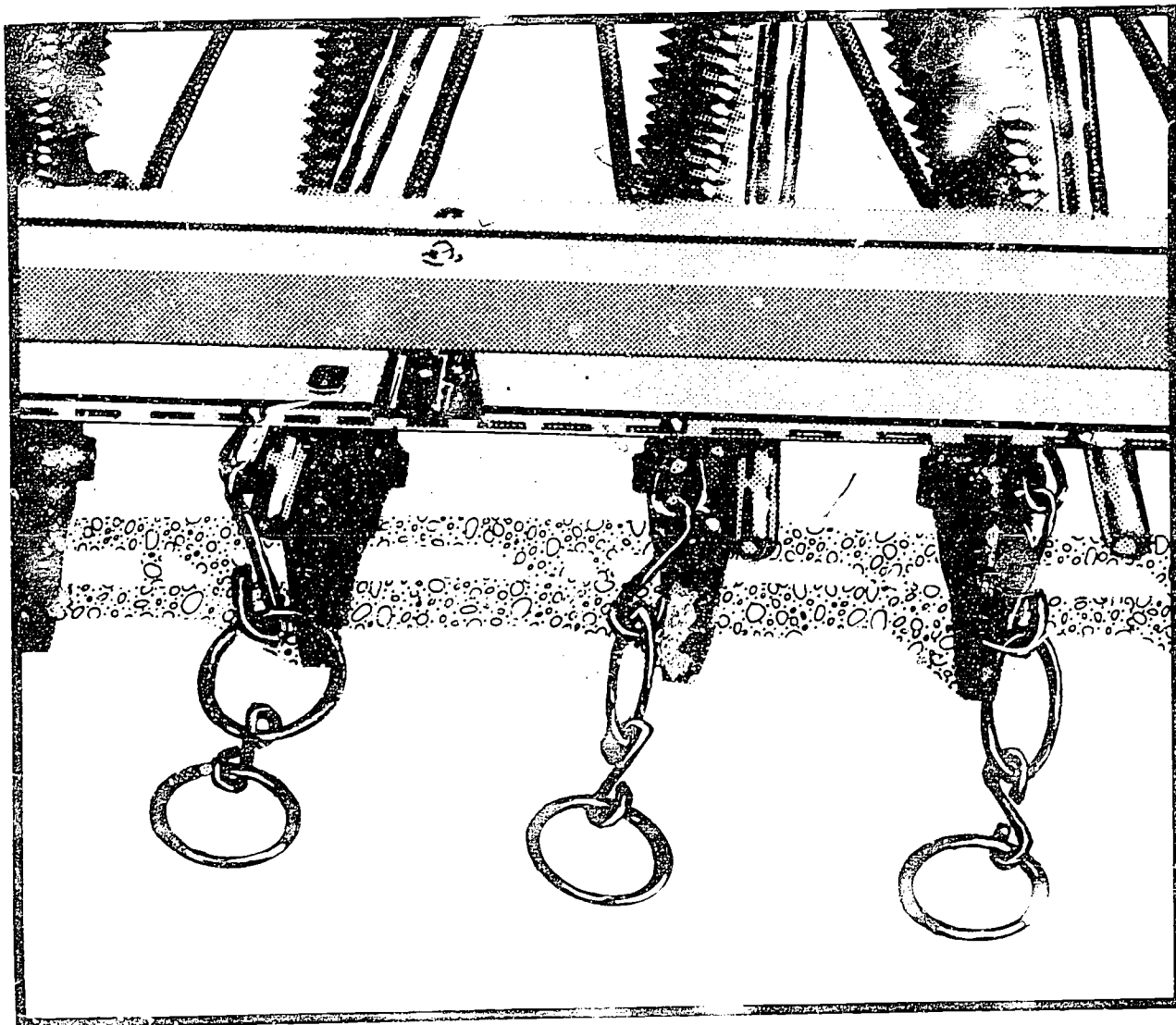

150

III-H-3-42

Methods of Covering Seeds With Drills  
B.

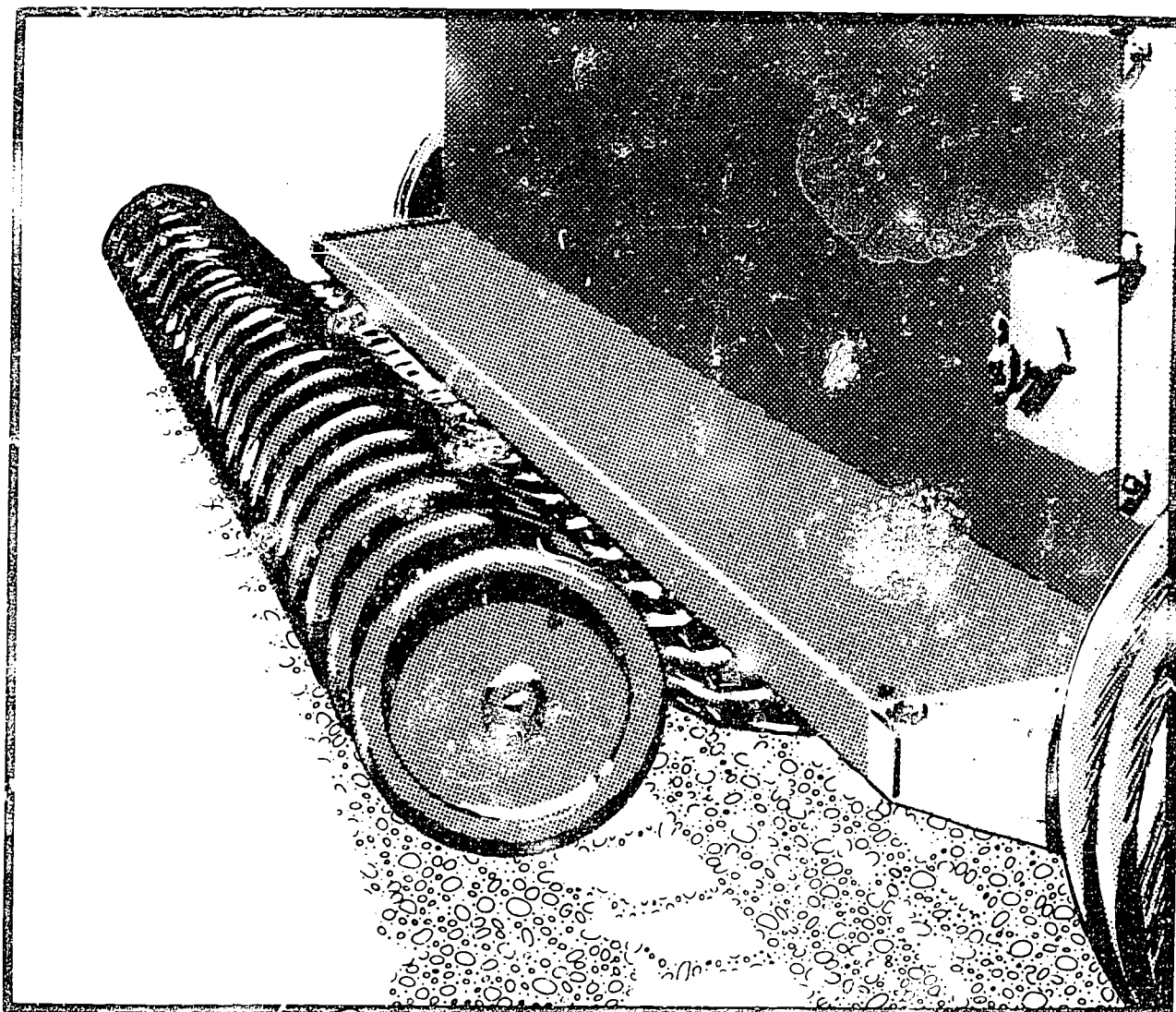



# Types of Feedcups on Drills

A.

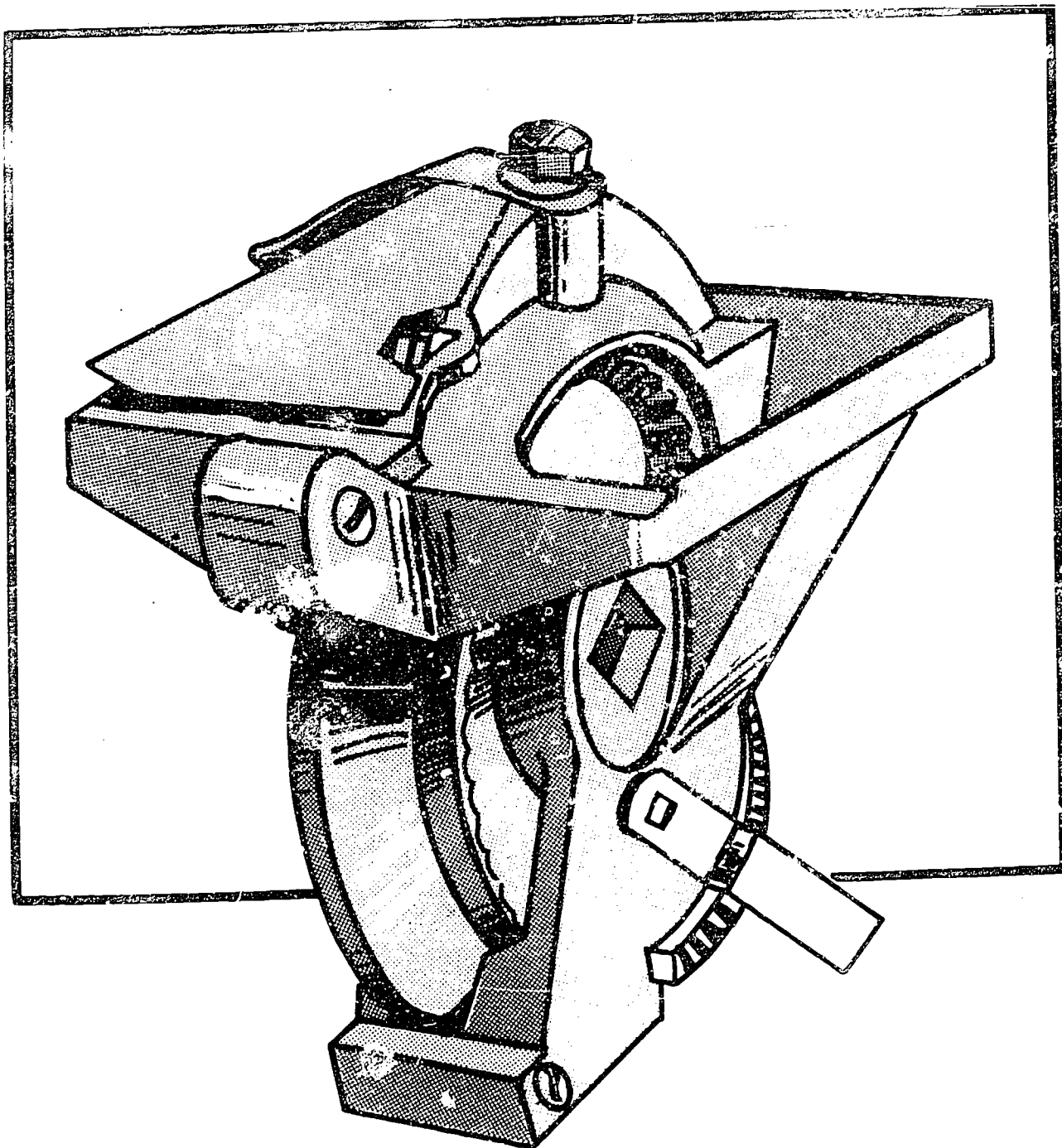

Types of Feedcups on Drills  
B.

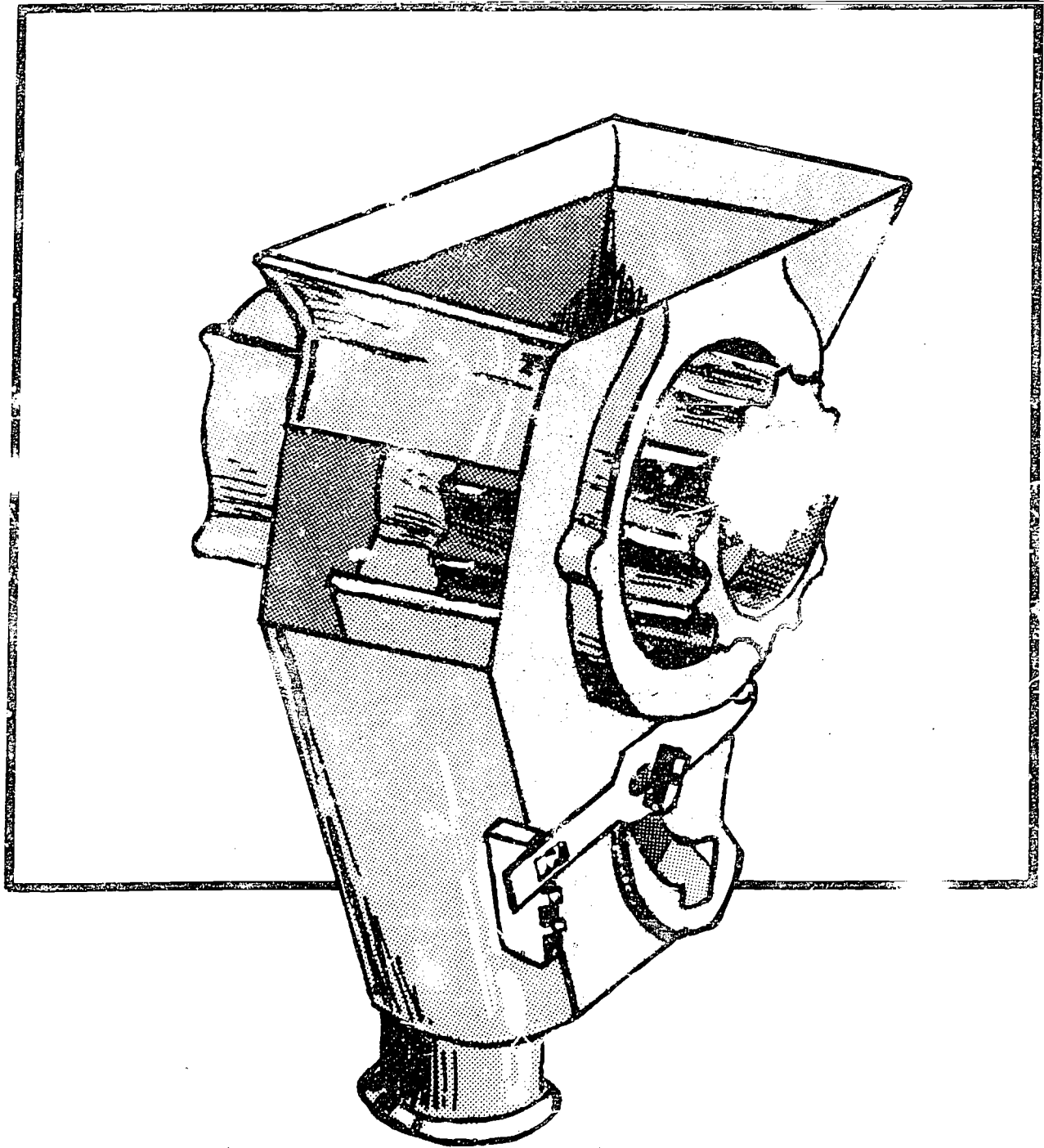

# Adjusting Seeding Rates

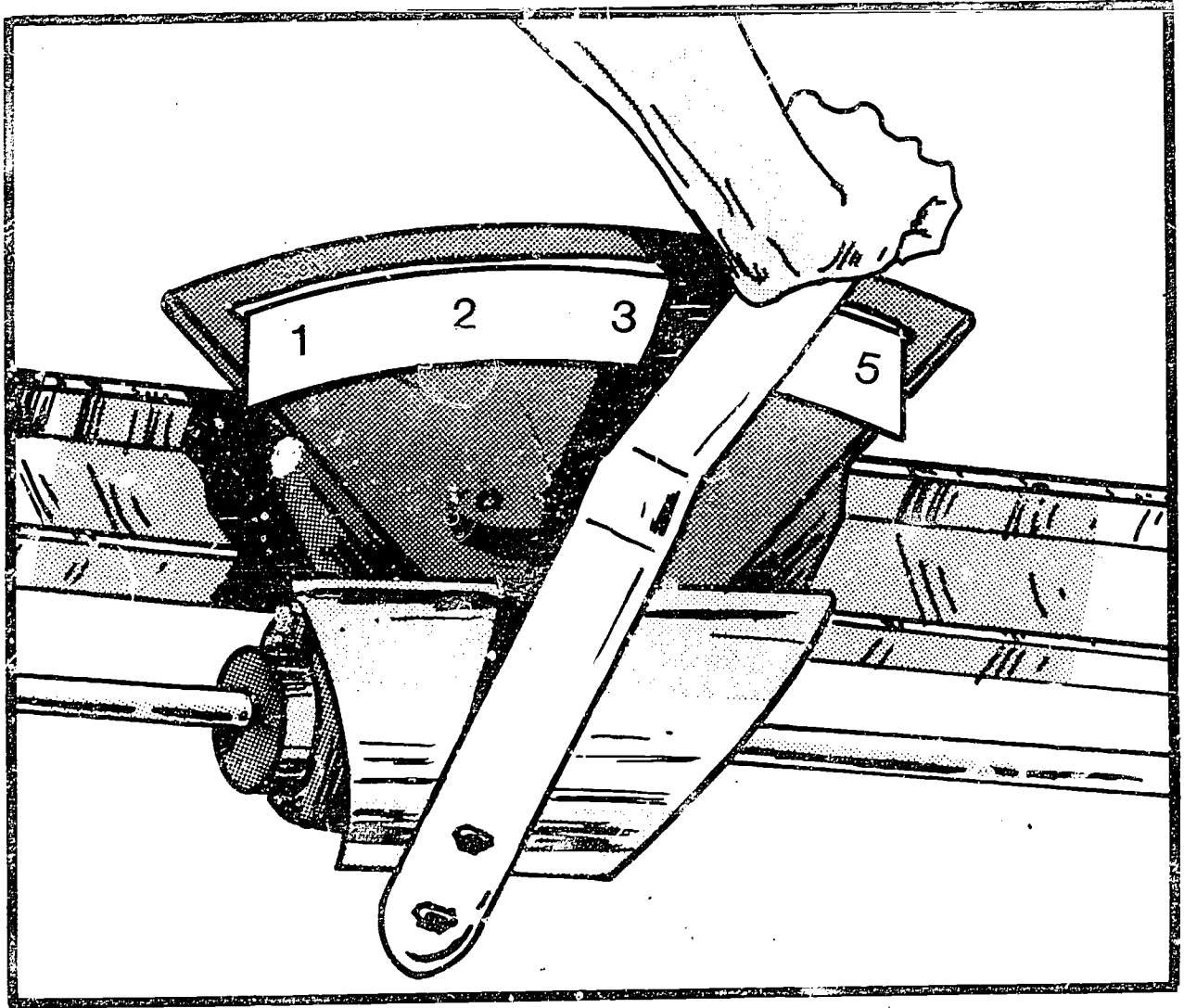

184

III-H-3-46

TRANSPARENCY DISCUSSION GUIDE  
ADJUSTING AND MAINTAINING PLANTING EQUIPMENT

Transparency -- PARTS OF A PLANTING UNIT

1. Have students identify the parts of the planting unit, and record the name on the transparency beside the part.
2. Ask the students to give the function of each part.
3. The parts listed are:
  1. Seed hopper
  2. Herbicide or insecticide hopper
  3. Insecticide tube
  4. Herbicide diffuser
  5. Seed firming wheels
  6. Depth adjustment
  7. Gauge wheels
  8. Furrow openers
  9. Coulter
  10. Frame

Transparency -- PARTS OF A PLATELESS AIR PLANTER

1. Ask students to identify the parts labeled and record on the transparency.
2. The parts listed are:
  1. Press wheel
  2. Marker
  3. Seed drum
  4. Seed hopper
  5. Fertilizer hopper
  6. Furrow opener
  7. Runner
  8. Seed tubes
  9. Fertilizer tubes
  10. Depth adjustment

Transparency -- METHODS OF COVERING SEED

1. Identify the two major ways of covering seeds with a planter. These are firming wheels and press wheels.
2. Discuss the advantages of the firming wheels over the press wheel.
3. Identify some of the common types of press wheels used on planters.

Transparency -- TYPES OF METERING DEVICES

Identify the three types of metering devices and how each operates.

- A. Seed Plate - has openings or cells, and rotates at the bottom of a seed hopper. As the seed plate turns the seed falls into the cells. Only one seed should fall into each cell. A spring loaded cutoff pawl keeps seeds other than the one in the seed plate cell from dropping from the hopper into the discharge tube.
- B. Finger Pickup - has spring loaded fingers that are opened and closed by a cam as they rotate. The corn is fed from the hopper into the reservoir by gravity. The fingers pick up and trap the kernel between

tween the finger and the stationary plate. It is then carried to the discharge hole where it is ejected into the seed placement mechanism.

- C. Air Metering - There is a seed drum which is ground driven to provide accuracy. Seed flows from the seed hopper to the seed drum. A fan pressurizes the central seed hopper and the seed metering drum. The seed drum has a row of holes around the circumference for each row being planted. The pressure inside the drum is higher and holds the seeds in the holes. As the drum rotates near the discharge manifold, a release wheel mounted on the outside of the seed drum blocks the hole. The seed falls by gravity into the seed discharge manifold, where it is pushed by air through a seed delivery tube to the row planting unit.

#### Transparencies -- PLANTER ADJUSTMENTS

1. The first transparency shows three different ways of adjusting the depth of planting. The newer planters may be adjusted by simply moving a handle higher or lower. Older models have a depth control strap which is used to adjust the planting depth.
2. Have students identify which type they have on their planters on their home farms.
3. The second transparency shows how to set the seeding rate, and the herbicide and insecticide rates. Make students aware that those shown in the transparency are only one method and there are other methods to make this adjustment.

#### Transparency -- PARTS OF A GRAIN DRILL

1. Have students identify the parts of the grain drill, and record the names of the part on the transparency.
2. Ask students to identify the function of each part.
3. The parts listed are:

1. Seed hopper	6. Frame
2. Fertilizer hopper	7. Seed metering control
3. Grass seed hopper	8. Furrow openers
4. Hydraulic cylinder	9. Seed tube
5. Hitch	10. Press wheel

#### Transparency -- METHODS OF COVERING SEED WITH A GRAIN DRILL

1. Discuss the advantages and disadvantages of each type of method.
2. Discuss the cover chains and the press wheels.

#### Transparency -- TYPES OF FEEDCUPS ON GRAIN DRILLS

Discuss the fluted and double run type.

Transparency -- ADJUSTING SEEDING RATE

The seeding rate is usually adjusted by moving a lever to increase or decrease the seeding rate.

TEACHER'S KEY

SAMPLE TEST QUESTIONS

ADJUSTING AND MAINTAINING PLANTING EQUIPMENT

True (+) and False (0)

- +   1. The purpose of the press wheel is to firm the seedbed.
- +   2. Row crop planters are sized according to the number of rows and the spacing between rows.
- 0   3. There are five major types of grain drills.
- +   4. Grain drills are usually sized according to the number of furrow openers, and the distance between them.
- 0   5. Planting depth should be adjusted before going to the field to plant.
- +   6. Planter markers should always be adjusted after adjusting row widths.
- 0   7. Leaving seeds in the hopper is a recommended storage practice.
- +   8. Furrow openers should be coated with oil or grease to prevent them from rusting.
- +   9. The inside of the fertilizer hopper can be coated with diesel fuel to prevent corrosion.
- +   10. Double disk is one of the four types of furrow openers.

MATCHING

Match the following crops to the most common type of planting method.

- |                 |                  |                     |
|-----------------|------------------|---------------------|
| <u>  B  </u>    | 1. Corn          | A. Drill            |
| <u>  A, B  </u> | 2. Soybeans      |                     |
| <u>  A  </u>    | 3. Wheat         | B. Row-crop planter |
| <u>  A  </u>    | 4. Oats          |                     |
| <u>  A  </u>    | 5. Grain sorghum |                     |
| <u>  B  </u>    | 6. Sweet corn    |                     |

Match the function with the part which will perform the function.

- |              |                        |                       |
|--------------|------------------------|-----------------------|
| <u>  C  </u> | 1. Open the soil       | A. Seed tube          |
| <u>  B  </u> | 2. Select the seed     | B. Metering mechanism |
| <u>  A  </u> | 3. Placing the seed    | C. Furrow opener      |
| <u>  E  </u> | 4. Covering the seed   | D. Press wheel        |
| <u>  D  </u> | 5. Firming the seedbed | E. Coverer            |

## SHORT ANSWER

Describe how each of the following adjustments are made.

Depth of planting

Row spacing

## ESSAY

Discuss how the three types of metering systems operate. The three types are seed plate, finger pickup, and air metering.



## UNIT H: AGRICULTURAL MECHANICS

### PROBLEM AREA: MAINTAINING AND REPAIRING SMALL ENGINES

#### SUGGESTIONS TO THE TEACHER:

This problem area is designed for use with eleventh grade or advanced students in vocational agriculture programs.

The estimated instructional time for this problem area is 20 to 30 days depending on how far the teacher wishes to go in developing student knowledge and skills in small engine maintenance. If the students are to be involved in other activity exercises, the instructional time will need to be increased. These materials were selected and developed with the following assumptions:

- A. Students may not have prior experience with small engines.
- B. School laboratories will have access to the basic mechanics' tools and small engine equipment.
- C. Students will have access to used small engines through the school or from home.
- D. Instructors will have made arrangements with small engine parts distributors to have available necessary replacement parts.

The instructor is encouraged to conduct a local search to locate other supplementary material for use with this problem area. The items in this problem area are for reference or modification as instructors adapt these materials to their local situation.

#### CREDIT SOURCES:

These materials were developed through a funding agreement, R-33-13-D-0362-466 with the Illinois State Board of Education, Department of Adult, Vocational and Technical Education, Research and Development Section, 100 North First Street, Springfield, Illinois 62777. Opinions expressed in these materials do not reflect, nor should they be construed as policy or opinion of the State Board of Education or its staff.

The teacher's guide, student worksheets, and test questions were developed by Richard Schertz, Vocational Agriculture Instructor, Moweaqua High School, Moweaqua, Illinois and Jerry Pepple, Agricultural Education Division, University of Illinois. Transparency masters and the transparency discussion guide were prepared by the Vocational Agriculture Service, University of Illinois. Suggestions and guidance in the development of these materials were provided by the Rural Core Curriculum Field Test Teachers. This problem area was reviewed by the following vocational agriculture teachers:

Richard Schertz	-	Moweaqua High School
Richard Watson	·	Raymond-Lincolnwood High School

Robert Wheeler - Flora High School  
Morris McClelland - Rushville High School  
Larry Melhouse - Avon High School

## TEACHER'S GUIDE

- I. Unit: Agricultural mechanics
- II. Problem area: Maintaining and repairing small engines
- III. Objectives: At the end of this problem area students will be able to:
  1. Name and visually identify the sequence of a complete cycle of a two- and four- stroke engine.
  2. Name the parts of a small engine which were identified in class and explain the function of each.
  3. Identify and use small engine tools and measuring devices safely and correctly.
  4. Disassemble, repair, and reassemble a small engine to the satisfaction of the owner and/or instructor.
- IV. Suggested interest approaches:
  1. Have students identify home and farm equipment that uses small engines. Develop a list of students' suggestions on the chalkboard.
  2. Develop class discussion on the job opportunities which require competencies in small engine operation.
  3. Organize a field trip to a small engine dealership and repair shop. Have students identify various job skills and interview the employers and employees concerning occupational requirements and opportunities.
  4. Bring a small engine into the classroom or take the class to the laboratory where a small engine is partially disassembled. Let students identify and explain the function of selected parts.
  5. Distribute copies of retail catalogs which advertise equipment using small engines. Have students identify the cost of a new engine versus the cost of overhauling the engine. Compare these expenses against the cost of timely preventative maintenance service.
  6. Ask students to relate any experiences they have had with small engines such as operation, maintenance or overhaul. Use Competency Inventory Sheet to identify essential skills.
- V. Anticipated problems and concerns of students:
  1. What are the differences between a four-stroke and two-stroke cycle engine?

2. What are the advantages and disadvantages of four-stroke and two-stroke engines?
3. Do we bring our own engines to work on?
4. When will we get to work on our engines in the shop?
5. Do I need to bring special shop clothes when I work on my engine to keep from getting dirty?
6. Will we disassemble and reassemble our own engines?
7. Will we work on multi-cylinder engines?
8. What type of service needs to be done regularly on small engines to keep them in good working condition?
9. Who are the major manufacturers of two and four-cycle engines?
10. Where can I purchase small engine parts?
11. What safety precautions need to be followed when working on small engines?

VI. Suggested learning activities and experiences:

1. Conduct an interest approach on small engines and then identify student problems and concerns. Use class discussion to answer and develop ideas for solving the identified problems and concerns.
2. Develop possible solutions to these problems and concerns. Use some or all the suggested teaching activities listed below to solve the remaining problems and concerns.
3. Have students identify possible sources of used small engines such as home farm, relative, local ag. business, or through an ad in the local newspaper requesting used small engines for service and repair.
4. Distribute VAS Unit 3014, "Small Engine - Principles of Operation, Trouble Shooting and Tune-Up". Handout Worksheet 1; "Small Engine Operation and Trouble Shooting". Have students answer the questions. Discuss their answers in class.
5. Distribute VAS Unit 3020, "The Two-Cycle Engine", and Worksheet #2, "Principles of Two-Cycle Engine Operation". Use this worksheet to identify the similarities and differences between two-cycle and four-cycle engines.
6. Have students select a small engine in the agriculture mechanics laboratory and have them disassemble the engine. During this exercise students should identify parts and observe actual operation sequences of the engine parts.

7. Conduct a teacher demonstration on the procedure to follow when disassembling an engine. Point out the principles of engine operation and part identification. This exercise could be completed concurrently with Worksheets 1 and 2.
8. Use Worksheet 3, "Identifying Small Engine Parts", and VAS transparencies to identify and explain carburetion systems on small engines and other small engine systems.
9. Distribute Worksheet 4, "Tools and Equipment for Small Engine Overhaul". Conduct class demonstrations on the identification and use of the special small engine overhaul tools. Have students complete the worksheet and hand in for evaluation. Give students an opportunity to practice using the small engine overhaul tools.
10. Distribute Worksheet 5, "Small Engine Repair and Overhaul" and Briggs and Stratton Repair Instruction Manual IV. Discuss the students' answers and conclusions before they disassemble their own engines.
11. Distribute Job Sheet 1, "Using and Reading Micrometers", have students complete the Job Sheet and practice using micrometers.
12. Have students bring in their own engines and the operators' manuals. Distribute and have students complete Worksheet 6, "Engine Specifications". Use VAS transparencies to discuss how to read and interpret name plate information which is essential when ordering replacement parts.
13. Distribute Job Sheet 2, "Four-Cycle Engine Overhaul". Have students bring in their own four-cycle engines or use engines owned by the school. Engines commonly used are vertical shaft lawnmower engines. Have students complete the overhaul of a small engine in ag. mechanics laboratory.
14. Provide individualized instruction to students as they disassemble, repair, and reassemble their engines. Demonstrate how to properly complete the activities in step #33 on Job Sheet 2.
15. Use Job Sheet 3, "Two-Cycle Engine Overhaul", if students are to overhaul two-cycle engines.
16. Collect and evaluate Job Sheets 2 and/or 3 after students have completed the overhaul of their engines and had them started.
17. Have students prepare their engines for off-season storage by using Job Sheet #4, "Off-Season Storage of Small Engines".

VII. Application procedures:

1. This unit may be used to emphasize agricultural mechanics in student's SOEP's.
2. This unit may also be used to help prepare students for the FFA Ag. Mechanics contest.

VIII. Evaluation of student progress:

1. Prepare and administer a pencil and paper test on materials covered in class.
2. Grade worksheets and job sheets completed by students.
3. Prepare and administer lab practical tests on measuring tools, identifying equipment, repairing engine parts, and other items.

IX. Instructional materials and aids:

1. Vocational Agriculture Service University of Illinois, Small Engine Transparencies.
2. Vocational Agriculture Service, University of Illinois, VAS Units #3014, #3020 and #3019.
  - a. Unit 3014, Small Engines - Principles of Operation, Trouble-shooting and Tune-up
  - b. Unit 3019, Small Engines - Repair and Overhaul
  - c. Unit 3020 - The Two Cycle Engine
  - d. Unit 3023, Micrometers and Related Measuring Tools
3. Midwest Engine Warehouse  
515 Romans Road  
Elmhurst, Illinois 60126  
(Regional Dealership for Briggs & Stratton)
  - a. "General Theories of Operation", Repair Instruction IV, and Small Engine Flip Charts, Briggs & Stratton Corporation, Milwaukee, Wisconsin

Note: The Briggs & Stratton Materials can be ordered through Midwest Engine Warehouse. Any school offering a small engine course can receive enough copies of "General Theories of Operation", and "Repair Instruction IV", manuals for the entire class plus one flip chart and one engine, free of charge. Additional engines, parts, and tools can be purchased through them at a reduced educational discount price.

4. Hobar Publications, Hoener-Ahrens-Bear, "Small Gasoline Engines - Operation & Maintenance", Hobar Enterprises, Inc.,

1305 Tiller Lane, St. Paul, Minnesota 55112. They also have small engine tools and equipment.

5. Other teaching and training aids:
  - a. Tecumseh Products Company  
Parts Depot Division  
Grafton, Wisconsin 53024
  - b. Kohler Company  
Kohler, Wisconsin 53044
  - c. Jacobsen Manufacturing Company  
1712 Packard Avenue  
Racine, Wisconsin 53403
  - d. Johnson Outboards  
200 Sea Horse Drive  
Waukegan, Illinois 60085
  - e. Lawn Boy  
P. O. Box 82409  
Lincoln, Nebraska 68501
  - f. Clinton Engines Corporation  
Maquoketa, Iowa 52060
  - g. Homelite Division of Textron Inc.  
Port Chester, New York 10573
  - h. McCulloch Corporation  
Los Angeles, California 90009
  - i. Teledyne Wisconsin Motor Company  
1910 South 53rd Street  
Milwaukee, Wisconsin 53219
6. Small Gas Engines, Gray, James A. and Burrow, Richard W. Prentice-Hall, Inc., Englewood Cliffs New Jersey. (also has workbook for students)
7. Small Gas Engines, Roth, Alfred C., The Good Heart-Willcox Company, Inc., South Holland, Illinois
8. Slidefilms - #450 Small Engines Explained, Hunter, Bruce. Bergwall Productions, Inc., Garden City, New York, 11530 (contains nine filmstrips, cassette tapes, and test questions)
9. Subject units, student workbooks, and transparencies are available from:

AAVIM, Curriculum Publications Clearinghouse, Horrabin Hall 47, Western Illinois University, Macomb, Illinois 61455. Ph. # 800-322-3905 or 309-298-1917

## COMPETENCY INVENTORY

### MAINTAINING AND REPAIRING SMALL ENGINES

1. Student has no knowledge of competency.
2. Student has read about competency.
3. Student has seen competency performed.
4. Student has performed competency.
5. Student has performed competency without supervision.
6. Student does possess skill.
7. Student does not possess skill.

Competency	Circle One						
1. Check oil levels and change oil	1	2	3	4	5		
2. Service air filters	1	2	3	4	5		
3. Read and follow operators and repair manuals	1	2	3	4	5		
4. Troubleshoot and identify fuel problems	1	2	3	4	5		
5. Troubleshoot and identify ignition problems	1	2	3	4	5		
6. Identify small engine components and systems	1	2	3	4	5		
7. Clean, gap and replace sparkplugs	1	2	3	4	5		
8. Install and gap ignition points	1	2	3	4	5		
9. Install ignition condensor	1	2	3	4	5		
10. Adjust carburetor mixture and speed adjustment	1	2	3	4	5		
11. Use torque wrench	1	2	3	4	5		
12. Use measuring instruments on small engines	1	2	3	4	5		
13. Disassemble and reassemble small engines	1	2	3	4	5		
14. Prepare engine for off-season storage	1	2	3	4	5		
15. Understands theory of engine operation						6	7
16. Understands prescribed shop safety procedures						6	7
17. Determine condition and degree of wear for various small engine parts						6	7
18.						6	7
19.						6	7
20.						6	7

These competencies outlined in the National Ag Occupations Competency Study, 1978, for entry level positions in agricultural production.

Name \_\_\_\_\_ Date \_\_\_\_\_



## STUDENT WORKSHEET 1

### SMALL ENGINE-OPERATION, TROUBLE SHOTING AND TUNEUP

1. Four- stroke cycle engines make \_\_\_\_\_ revolution(s) of the crankshaft for each power stroke of the piston.
2. On the intake stroke, the intake valve \_\_\_\_\_ while the exhaust valve remains \_\_\_\_\_.
3. During the compression and power stroke both valves are \_\_\_\_\_.
4. On the exhaust stroke, the exhaust valve \_\_\_\_\_ while the intake valve remains \_\_\_\_\_.
5. Two-stroke cycle engines make \_\_\_\_\_ revolution(s) of the crankshaft for each power stroke of the piston.
6. The intake valve of many two- cycle engines is a \_\_\_\_\_ type which \_\_\_\_\_ only one way. Other two-cycle engines may have a \_\_\_\_\_ valve which is timed to open when the piston starts moving on the compression stroke.
7. The four- cycle engine may be subject to slightly less trouble in \_\_\_\_\_ and will operate more smoothly at \_\_\_\_\_ speeds.
8. Two- cycle engines produce more \_\_\_\_\_ per unit of \_\_\_\_\_ since there is a power stroke every revolution of the crankshaft.
9. The four distinct strokes for one complete cycle are \_\_\_\_\_, \_\_\_\_\_, \_\_\_\_\_, and \_\_\_\_\_.
10. Three primary essentials for the operation of any internal combustion engine are \_\_\_\_\_, \_\_\_\_\_, and \_\_\_\_\_.
11. The true sealing of piston and cylinder walls is done by \_\_\_\_\_.
12. Upper rings are solid and called \_\_\_\_\_ rings and the bottom ring is perforated and is called an \_\_\_\_\_.
13. Piston displacement refers to the \_\_\_\_\_ displaced by the piston in its travel.
14. Piston displacement = \_\_\_\_\_
15. The piston displacement for an engine with a 3-inch bore and 3-inch stroke is \_\_\_\_\_.
16. A comparison between the volume of the cylinder when the piston is at the bottom of its stroke and the volume of the cylinder when it is at the top of its stroke is called the \_\_\_\_\_.

17. At high speeds each valve must open and close in \_\_\_\_\_ of a second or less.
18. List the 6 parts of the valve system.

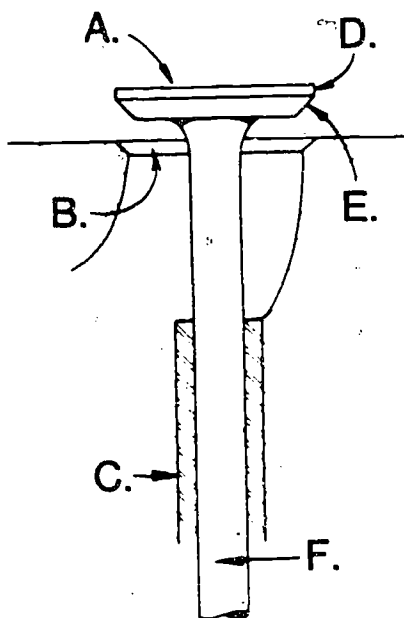

- A. \_\_\_\_\_
- B. \_\_\_\_\_
- C. \_\_\_\_\_
- D. \_\_\_\_\_
- E. \_\_\_\_\_
- F. \_\_\_\_\_

19. The functions of the carburetor system are to \_\_\_\_\_,
- \_\_\_\_\_.
20. The parts of the carburetion system include the \_\_\_\_\_,
- \_\_\_\_\_, \_\_\_\_\_, and \_\_\_\_\_.
21. The three types of carburetion systems are \_\_\_\_\_, \_\_\_\_\_, and \_\_\_\_\_.
22. The restricted section of the air passage is called the \_\_\_\_\_. Its purpose is to \_\_\_\_\_ the velocity of air.
23. Two common types of governors are the \_\_\_\_\_ and \_\_\_\_\_.
24. Most carburetors have a second jet which opens into the air passage just above the butterfly when it is in the closed position. This is called the \_\_\_\_\_.

25. Starting a cold engine requires a richer fuel mixture, this is accomplished by closing the \_\_\_\_\_.
26. Three types of air cleaners used on small engines are \_\_\_\_\_, \_\_\_\_\_, and \_\_\_\_\_.
27. Small engines generally have a \_\_\_\_\_ as the source of energy to produce electric spark.
28. Many small engine magnetos are of the \_\_\_\_\_ type.
29. The ends of the primary coil windings are connected to the \_\_\_\_\_ and the ends of the secondary coil windings are connected to the \_\_\_\_\_.
30. In small engines, the points are normally \_\_\_\_\_ and a spark occurs once every \_\_\_\_\_ of the crankshaft.
31. Most small engines are \_\_\_\_\_ cooled rather than liquid cooled.
32. The \_\_\_\_\_ provides the small engine with a fan for cooling.
33. The three types of lubrication systems found in four-cycle engines are \_\_\_\_\_, \_\_\_\_\_, and \_\_\_\_\_.
34. Low compression in small engine is generally the result of worn \_\_\_\_\_ or \_\_\_\_\_.
35. If compression is satisfactory, the next check is the \_\_\_\_\_.
36. If flooding has occurred without an abnormal amount of choking the engine, you may suspect a plugger \_\_\_\_\_.
37. Spark plug gaps are checked with a \_\_\_\_\_.
38. \_\_\_\_\_ on the points is a common source of ignition-system trouble in small engines.
39. When adjusting the carburetor during the final tuneup, set the \_\_\_\_\_ adjustment first, then the \_\_\_\_\_ jet.

## STUDENT WORKSHEET 2

### THE TWO-CYCLE ENGINE

1. The two-cycle engine takes two strokes of the piston to go through one cycle. It has no \_\_\_\_\_, \_\_\_\_\_, or \_\_\_\_\_.
2. The two-cycle engine uses its \_\_\_\_\_ as a fuel mixture transfer pump.
3. The charging of the crankcase, compression of the fuel charge and ignition must occur on the \_\_\_\_\_ stroke, where as exhaust and intake occurs on the \_\_\_\_\_ stroke.
4. The two types of valves used on two-cycle engines are \_\_\_\_\_ and \_\_\_\_\_.
5. Lubrication of a two-cycle engine depends on addition of \_\_\_\_\_ to the \_\_\_\_\_.
6. The use of \_\_\_\_\_ grade gasoline is recommended for two-cycle engines.
7. A carburetor consists of four parts:
  - a.
  - b.
  - c.
  - d.
8. A pound of fuel requires \_\_\_\_\_ pounds of air to burn properly.
9. Identify the carburetor parts.

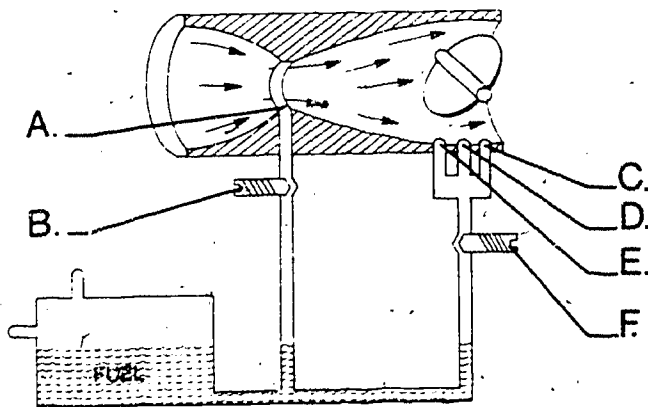

201

- A. \_\_\_\_\_
- B. \_\_\_\_\_
- C. \_\_\_\_\_
- D. \_\_\_\_\_
- E. \_\_\_\_\_
- F. \_\_\_\_\_

10. The \_\_\_\_\_ provides an exceedingly rich mixture when starting cold engines.
11. While \_\_\_\_\_ type carburetors can be used on two-cycle engines, chain saws usually require the \_\_\_\_\_ type carburetor.
12. The diaphragm type carburetor can be used in any \_\_\_\_\_.
13. The inlet valve can be either a \_\_\_\_\_ or \_\_\_\_\_ type.
14. Chain saw engines make use of \_\_\_\_\_ pressures to pump fuel into the carburetor.
15. Because of dirt, chain saw engines are provided with both \_\_\_\_\_ and \_\_\_\_\_ filters.
16. Both magnet and battery powered ignition systems require a \_\_\_\_\_, \_\_\_\_\_, \_\_\_\_\_, and \_\_\_\_\_.
17. The inner or \_\_\_\_\_ winding of the coil contains a few feet of wire where as the outer or \_\_\_\_\_ winding contains many feet of very fine wire.
18. The breaker points are two small circular pads of \_\_\_\_\_.
19. The \_\_\_\_\_ is used to absorb surges of electricity across the points.
20. The \_\_\_\_\_ of a spark plug gap is very important.
21. The spark plug fires when the \_\_\_\_\_ open.
22. When an engine doesn't run or put out full power, check \_\_\_\_\_, \_\_\_\_\_, and \_\_\_\_\_.
23. Check the ignition by unscrewing the \_\_\_\_\_ and \_\_\_\_\_ it by holding the threaded part of the plug to the engine's bare metal.

24. Most carburetor troubles are caused by improper adjustment of the \_\_\_\_\_ and \_\_\_\_\_ adjustment needles.
25. Explain how to check if the combustion chamber is receiving fuel.
26. Check engine compression by pulling the starter rope, then slackening the rope and noting the amount of engine \_\_\_\_\_.
27. A compression gauge should indicate at least \_\_\_\_\_ pounds of pressure for adequate engine operation.
28. The nine items which should be checked on the ignition system are:
- a.
  - b.
  - c.
  - d.
  - e.
  - f.
  - g.
  - h.
  - i.
29. The six items which should be checked on the fuel system are:
- a.
  - b.
  - c.
  - d.
  - e.
  - f.
30. The four things which should be checked for loss of power are:
- a.
  - b.

205

c.

d.

31. Preignition is:

32. Detonation is:

WORKSHEET 3

SMALL ENGINE PART IDENTIFICATION

1. Identify the following parts on the four-cycle small engine.

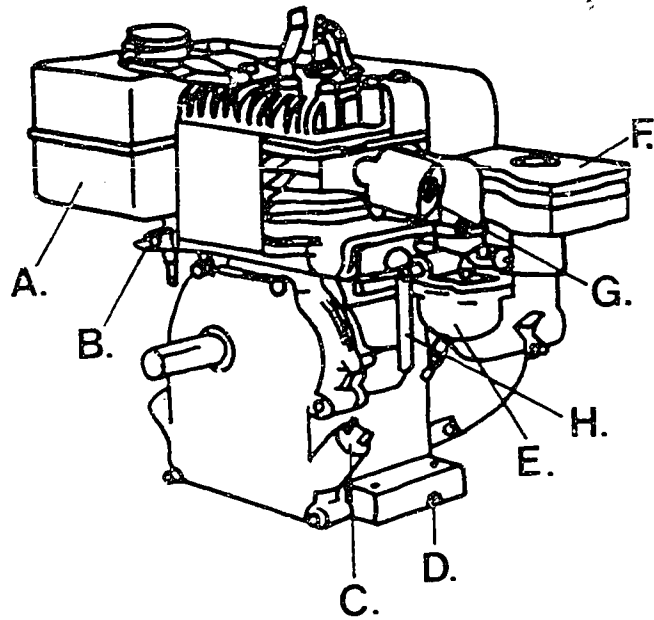

- |          |          |
|----------|----------|
| A. _____ | E. _____ |
| B. _____ | F. _____ |
| C. _____ | G. _____ |
| D. _____ | H. _____ |

2. Identify the following types of carburetors.

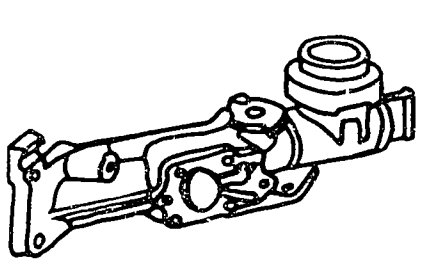

A. \_\_\_\_\_

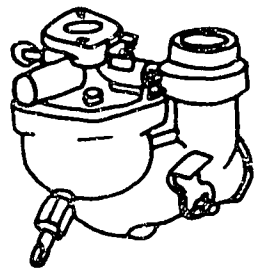

B. \_\_\_\_\_

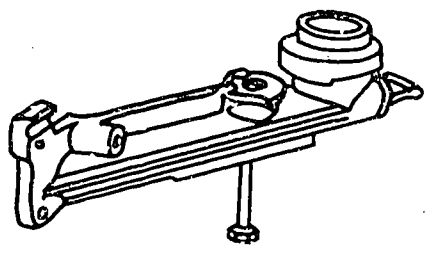

C. \_\_\_\_\_

205



3. Identify the following parts of the carburetor.

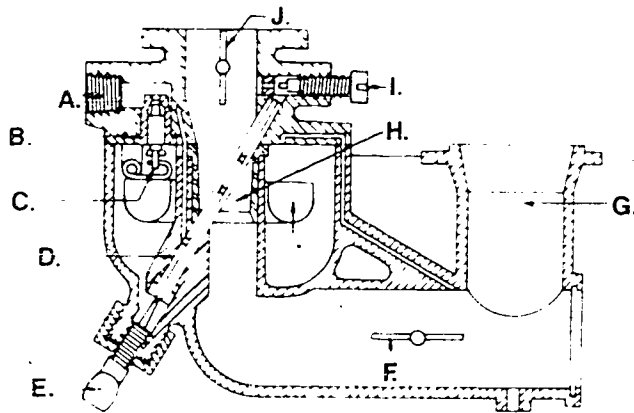

- |    |       |    |       |
|----|-------|----|-------|
| A. | _____ | F. | _____ |
| B. | _____ | G. | _____ |
| C. | _____ | H. | _____ |
| D. | _____ | I. | _____ |
| E. | _____ | J. | _____ |

4. Identify the following parts of the cut-away engine.

- A. \_\_\_\_\_
- B. \_\_\_\_\_
- C. \_\_\_\_\_
- D. \_\_\_\_\_
- E. \_\_\_\_\_
- F. \_\_\_\_\_
- G. \_\_\_\_\_
- H. \_\_\_\_\_
- I. \_\_\_\_\_
- J. \_\_\_\_\_
- K. \_\_\_\_\_

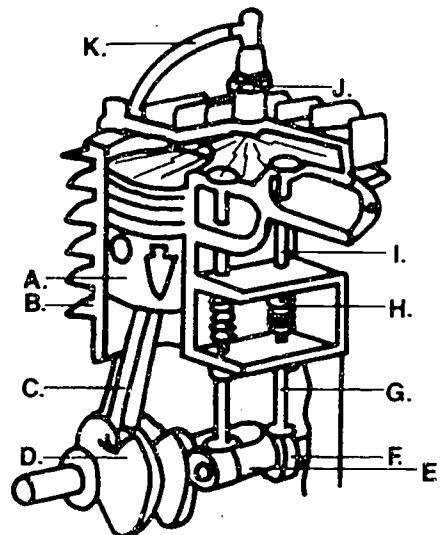

5. Identify the following parts of the small engine magneto ignition system.

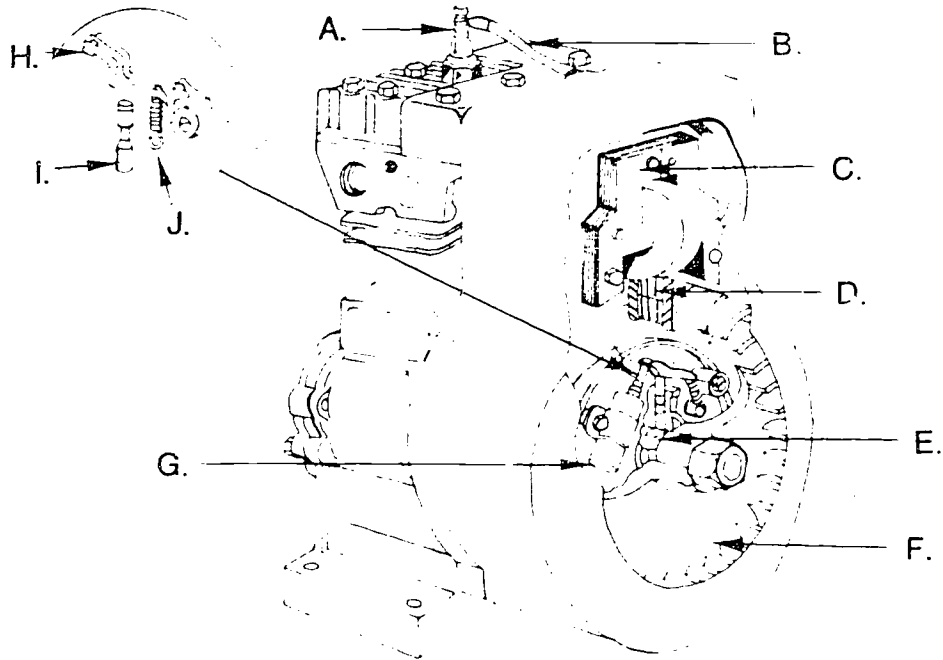

- A. \_\_\_\_\_
- B. \_\_\_\_\_
- C. \_\_\_\_\_
- D. \_\_\_\_\_
- E. \_\_\_\_\_
- F. \_\_\_\_\_
- G. \_\_\_\_\_
- H. \_\_\_\_\_
- I. \_\_\_\_\_
- J. \_\_\_\_\_

207

## WORKSHEET 4

### TOOLS AND EQUIPMENT FOR SMALL ENGINE OVERHAUL

1. A shop-made \_\_\_\_\_ holder will fit a variety of engines.
2. A special flywheel holder wrench is used to take off \_\_\_\_\_ mechanism starters.
3. A flywheel \_\_\_\_\_ is used to remove flywheels.
4. A \_\_\_\_\_ is used to control valve springs when removing and replacing valves.
5. A \_\_\_\_\_ is used for removing and replacing piston rings.
6. A \_\_\_\_\_ is used for replacing pistons in the cylinder.
7. The two types of thickness gauges are \_\_\_\_\_ and \_\_\_\_\_.
8. Outside micrometers are used to measure \_\_\_\_\_, \_\_\_\_\_, and other external \_\_\_\_\_.
9. \_\_\_\_\_ are used for measuring holes or slats.
10. A \_\_\_\_\_ measures engine parts for wear and dimensions.
11. The \_\_\_\_\_ can measure the amount of twisting force applied to bolts.
12. A \_\_\_\_\_ can be used to remove the carbon ridge at the top of cylinder walls.
13. You should use a \_\_\_\_\_ to deglaze cylinder walls before new piston rings are installed.
14. The piston ring gap can be checked with a \_\_\_\_\_.
15. The device used to reface valves and valve seats is a \_\_\_\_\_.
16. Three types of valve repair tools are \_\_\_\_\_, \_\_\_\_\_, and \_\_\_\_\_.
17. The \_\_\_\_\_ indicator measures crankshaft end play and out of roundness.
18. A \_\_\_\_\_ gauge checks the engine compression.
19. Reject gauges are used to check \_\_\_\_\_, \_\_\_\_\_, and \_\_\_\_\_.

20 Explain how to use plastigage.

21. Identify the following small engine tools.

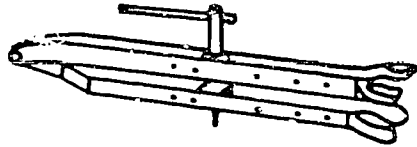

A. \_\_\_\_\_

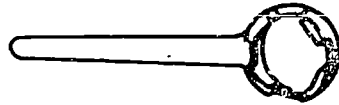

B. \_\_\_\_\_



C. \_\_\_\_\_

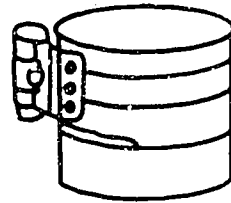

D. \_\_\_\_\_

203



E. \_\_\_\_\_



F. \_\_\_\_\_

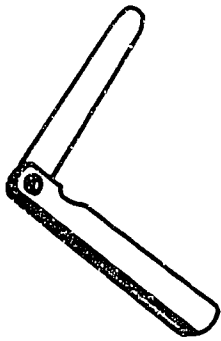

G. \_\_\_\_\_

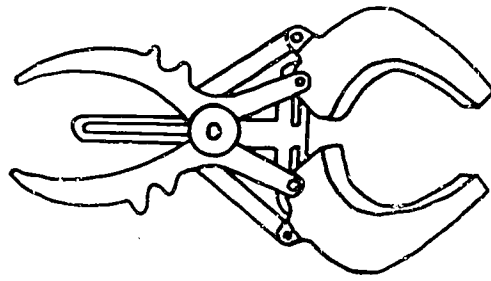

H. \_\_\_\_\_

## STUDENT WORKSHEET 5

### SMALL ENGINES - REPAIR AND OVERHAUL

#### A. DISASSEMBLING THE ENGINE

1. Before taking the engine apart, \_\_\_\_\_ it thoroughly.
2. Drain the \_\_\_\_\_ and \_\_\_\_\_ from the engine.
3. The eight things which should be removed when disassembling the engine are:
  - a.
  - b.
  - c.
  - d.
  - e.
  - f.
  - g.
  - h.

#### B. MEASURING CYLINDER, PISTON AND RING WEAR

1. It is important first to determine the \_\_\_\_\_ and amount of \_\_\_\_\_ in the cylinder.
2. Use a \_\_\_\_\_ gauge to measure piston diameter.
3. Explain how to measure the cylinder for out-of-round.
4. Explain how to measure the cylinder taper.
5. Two common reasons for rejecting a piston are:
  - a.
  - b.
6. Piston ring end gap should be measured for each \_\_\_\_\_ ring and \_\_\_\_\_ ring.

C. CHECKING CRANKSPIN AND BEARING

1. The crankspin should be checked for three things: \_\_\_\_\_, \_\_\_\_\_, and \_\_\_\_\_.
2. A convenient way to measure bearing clearance is to use a \_\_\_\_\_ thread (\_\_\_\_\_).

D. REPLACING THE PISTON

1. Before replacing the piston you should \_\_\_\_\_ the cylinder wall thoroughly.
2. Clean piston \_\_\_\_\_ grooves.
3. Use a \_\_\_\_\_ expander to install rings on the piston.
4. The piston of a two cycle engine may have a small \_\_\_\_\_ or \_\_\_\_\_ in each ring groove to keep the ring from turning.
5. Explain how to install the piston in the cylinder.
  - a.
  - b.
  - c.
  - d.

E. SERVICING THE VALVES

1. The four things which should be serviced on the valves are:
  - a.
  - b.
  - c.
  - d.

F. REPLACING THE ENGINE HEAD

1. Use a \_\_\_\_\_ wrench when tightening the engine head to specifications.
2. \_\_\_\_\_ tighten the bolts on one side and the other so that the head is drawn down evenly.

G. REPAIRING THE CARBURETOR AND FUEL SYSTEM

1. The two types of carburetors that should be serviced are the \_\_\_\_\_ type and \_\_\_\_\_ type.

H. SERVICING THE IGNITION SYSTEM

1. If the \_\_\_\_\_ are pitted or burned they should be replaced.

2. Inspect the spark plug for \_\_\_\_\_, \_\_\_\_\_, or \_\_\_\_\_.
3. The three kinds of spark to look for when testing the coil and ignition wiring are \_\_\_\_\_, \_\_\_\_\_, and \_\_\_\_\_.
4. Magneto air gap is the distance between rotating \_\_\_\_\_ in the flywheel and the \_\_\_\_\_ laminations of the coil.
5. The two types of coil and armature are \_\_\_\_\_ the flywheel and \_\_\_\_\_ the flywheel.
6. Specified magneto output should jump a gap of \_\_\_\_\_.

#### I. OPERATING AND CHECKING THE ENGINE

1. Explain the things which should be installed or adjusted before starting the engine.
2. Explain how to set the main fuel jet and idle screw with the engine running.



J. READ THE FOLLOWING STATEMENTS ON SAFETY AND PLACE AN "A" BY THOSE STATEMENTS WHICH WOULD BE GOOD "APPROVED PRACTICES" TO OBSERVE.

- 1. Storing gasoline in approved metal containers.
- 2. Removing gasoline from the gas tank and carburetor before repairing an engine.
- 3. Refilling a gasoline tank with the engine running.
- 4. Working in a well-ventilated shop.
- 5. Using an approved solvent for cleaning engine parts.
- 6. Removing the spark plug wire before servicing or repairing an engine.
- 7. Having dry chemical fire extinguishers available.
- 8. Following good work habits.
- 9. Reading and following your operator's and/or service manual.
- 10. Cleaning the engine before it is serviced.
- 11. Using gasoline for cleaning engine parts.
- 12. Working on a hot engine.
- 13. Storing greasy shop rags in a metal air-tight container.
- 14. Cleaning wrenches and other tools before storing.
- 15. Securing the engine in an approved mount before starting to work on the engine.
- 16. Operating the engine with the governor disconnected.
- 17. Operating a vertical shaft engine with a special flywheel when adjusting the governor and carburetor.
- 18. Test-running the engine without the engine shroud which covers the flywheel.
- 19. Handling volatile fuels in a shop or area which has an open flame.
- 20. Removing all fuel from an engine before placing it in dry storage.
- 21. To operate an engine which has gasoline dripping from the fuel system.

- 22. Operating an engine with the muffler removed.
- 23. Assembling the engine using all bolts and cap screws of the specified grade.
- 24. Using a starter rope which is not frayed.
- 25. Using "either type" starter fluids to start small engines.
- 26. Using a torch to repair leaks in a gasoline tank.
- 27. Operating a vertical shaft lawn mower with a cracked or bent blade.
- 28. Spilling gasoline on a hot engine.
- 29. Wearing safety glasses when in the shop.
- 30. Using an approved flywheel holder when removing a flywheel nut.
- 31. Keep hands and face away from carburetors when cranking an engine if the air cleaner is removed.

215

STUDENT WORKSHEET 6

FOUR-CYCLE ENGINE SPECIFICATIONS

Using the small engines assigned to you by your instructor, complete the following information on a four-cycle and two-cycle small engine.

(Refer to owner/operator manuals and small engine)

1. Name of motor \_\_\_\_\_
2. Serial number \_\_\_\_\_
3. Model number \_\_\_\_\_
4. Idle R.P.M. \_\_\_\_\_
5. High speed R.P.M. \_\_\_\_\_
6. Crankshaft - vertical or horizontal \_\_\_\_\_
7. Piston - vertical or horizontal \_\_\_\_\_
8. Type of lubrication system \_\_\_\_\_
9. Engine horsepower \_\_\_\_\_
10. Diameter of cylinder \_\_\_\_\_
11. Length of stroke \_\_\_\_\_
12. Spark plug gap \_\_\_\_\_
13. Point gap \_\_\_\_\_
14. Condenser capacity \_\_\_\_\_
15. Flywheel air gap \_\_\_\_\_
16. Type of oil recommended in summer  
in winter \_\_\_\_\_
17. Type of carburetor \_\_\_\_\_
18. Type of governor \_\_\_\_\_
19. Type of air cleaner \_\_\_\_\_
20. Type of starting mechanism \_\_\_\_\_

#218

III-H-4-29

## TWO-CYCLE ENGINE SPECIFICATION

(Refer to owner/operator manuals and small engine)

1. Make of engine \_\_\_\_\_
2. Model number \_\_\_\_\_
3. Serial number \_\_\_\_\_
4. Grade of gasoline recommended \_\_\_\_\_
5. Type of oil recommended \_\_\_\_\_
6. Breaker point gap \_\_\_\_\_
7. Type (size) of spark plug \_\_\_\_\_
8. Spark plug gap \_\_\_\_\_
9. Type of carburetor \_\_\_\_\_
10. Type of air cleaner \_\_\_\_\_
11. High speed R.P.M. \_\_\_\_\_
12. Type of choke system \_\_\_\_\_
13. Armature air gap \_\_\_\_\_

217

JOB SHEET 1

USING SMALL ENGINE MEASURING TOOLS

OBJECTIVES:

1. To be able to identify the parts of a micrometer.
2. To be able to correctly read a micrometer.
3. To be able to correctly read a flat feeler gauge.

MATERIALS:

1. six-inch micrometer with interchangeable anvils
2. crankshaft
3. valve
4. camshaft
5. assembled small engine
6. VAS Unit 3023, Micrometers and Related Measuring Tools

PROCEDURE:

1. Identify the following parts of a micrometer.

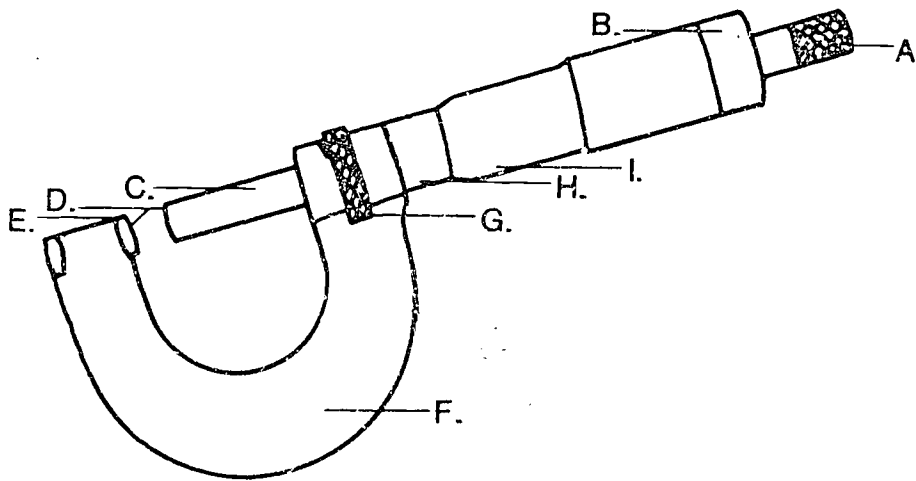

A. \_\_\_\_\_  
B. \_\_\_\_\_  
C. \_\_\_\_\_  
D. \_\_\_\_\_  
E. \_\_\_\_\_  
F. \_\_\_\_\_

G. \_\_\_\_\_  
H. \_\_\_\_\_  
I. \_\_\_\_\_

2. Practice reading the micrometer scales by following these steps:
- Read the highest figure visible on the barrel.
  - Add .015 inch for each line between the number and the thimble edge.
  - Add the number of the line on the thimble that coincides with or has passed the reference line.
  - Add the number of the graduation on the vernier that coincides with a line on the thimble.
  - Add the above figures for the measurement.

Select the correct reading for each of the following:

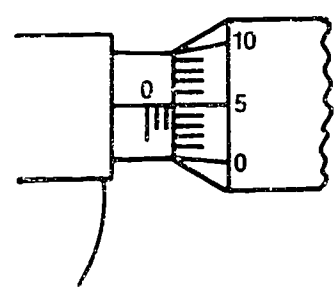

A. \_\_\_\_\_

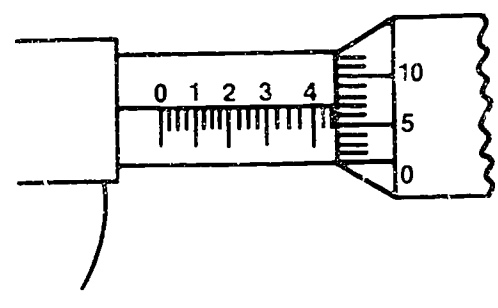

B. \_\_\_\_\_

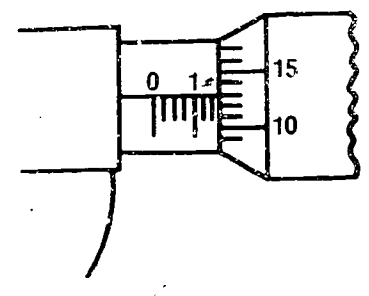

C. \_\_\_\_\_

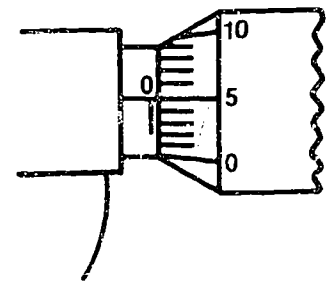

D. \_\_\_\_\_

3. Using a micrometer measure the following small engine parts. Compare your measurements with the standards listed in a repair manual. Determine if the part can be used or if it should be rejected.

	Measurement	Recommendation
a. crankpin	_____	_____
b. cylinder wall	_____	_____
c. flywheel journal	_____	_____
d. PTO journal	_____	_____

4. Using an engine assigned by your instructor, use a feeler gauge to determine the following air-gaps. Compare your measurements with the standards listed in your repair manual.

	Measurement	Recommendation
a. spark plug	_____	_____
b. intake valve	_____	_____
c. exhaust	_____	_____
d. armature	_____	_____
e. ignition points	_____	_____

## JOB SHEET 2

### FOUR-CYCLE ENGINE OVERHAUL

#### OBJECTIVES:

1. To develop the ability to troubleshoot a four-cycle engine.
2. To develop the ability to correctly disassemble, repair, and reassemble a four-cycle engine.

#### MATERIALS:

1. Used four-cycle engine
2. Mechanics' tools
3. Service and repair manual

#### PROCEDURE:

Select a suitable work station, a small engine, and the necessary mechanics' tools. Be sure you have financing available to replace necessary parts. Observe all shop safety rules!!

#### FOLLOW ALL DIRECTIONS

1. Engine Manufacturer \_\_\_\_\_  
Serial Number \_\_\_\_\_  
Model Number \_\_\_\_\_  
Type Number \_\_\_\_\_
2. Do a compression test by giving the flywheel a quick spin. Does the flywheel rebound sharply? \_\_\_\_\_ What is the actual compression? \_\_\_\_\_
3. Check the crankshaft end play. \_\_\_\_\_ What is the recommended range? \_\_\_\_\_
4. What is the condition of the spark plug? \_\_\_\_\_ Is there spark?  
\_\_\_\_\_
5. Drain the oil....remove the spark plug....and muffler.
6. Draw a sketch of the governor linkage in respect to the carburetor and the governor system. (Use reference book if necessary.)



7. Remove the air cleaner...carburetor...gas tank...governor linkage.  
\*\*Remember the position of these parts!!!
8. Remove the engine shroud. Does the starter pull evenly and smoothly?  
\_\_\_\_\_
9. Remove the crankshaft screen (if any), nut, and starter mechanism.  
What tools did you use?  
\_\_\_\_\_
10. Using a flat feeler gauge, measure and report the armature air-gap clearance.
  - a. armature air gap found \_\_\_\_\_
  - b. manufacturers' recommendation \_\_\_\_\_
10. Remove the flywheel.
11. What is the condition of the flywheel key? \_\_\_\_\_ What is the purpose of having a soft key in the crankshaft groove?  
\_\_\_\_\_  
\_\_\_\_\_
12. Remove the breaker-point cover. Make a sketch of the ignition system. Include armature and coil unit, breaker points, condenser, spark plug, and all wires. Are the parts and wires installed properly and in good condition? \_\_\_\_\_

LABEL ALL PARTS OF SKETCH.

13. Check the breaker point gap with a feeler gauge.
  - a. gap found \_\_\_\_\_
  - b. manufacturers' recommendation \_\_\_\_\_
  
14. Check the spark plug gap with a feeler gauge.
  - a. gap found \_\_\_\_\_
  - b. manufacturers' recommendation \_\_\_\_\_
  
15. Remove the cylinder head and head gasket. DRAW a picture of the head and where and what length of bolts are placed.
  
16. Remove valve cover plate.
  
17. Measure and report the valve tappet clearance for each valve. (To measure the valve has to be closed)
 

Intake _____	Exhaust _____
Manufacturers' recommendation	
Intake _____	Exhaust _____
  
18. Remove valve springs and valves. KEEP the same springs with the same valves. What are the conditions of the valve springs, valves, and valve face and seats?
   
\_\_\_\_\_
   
\_\_\_\_\_
  
19. Remove the crankcase cover plate.
  
20. NOTE: The position of the timing marks on the crankshaft and camshaft gears.
  
21. Remove the camshaft and tappets.
  
22. Mark the connecting rod cap and connecting rod. Unbolt the connecting rod cap and use plastigage to measure the clearance.
   
\_\_\_\_\_
   
Manufacturers' recommendation \_\_\_\_\_
  
23. If needed use a ridge reamer tool to remove the ridge at the top of the cylinder.

24. Push the piston and rod out the top of the cylinder.
25. Remove the crankshaft. Measure and report the crankpin size \_\_\_\_\_  
 What is the reject size? \_\_\_\_\_
26. Measure and report the size of crankshaft journals. What are the reject sizes?  
 Magneto journal \_\_\_\_\_  
 PTO journal \_\_\_\_\_
27. How many rings does this engine have? \_\_\_\_\_ Name them.  
 \_\_\_\_\_
28. CAREFULLY.....remove the top ring from the piston. Place it about one inch down into the cylinder. Measure and report ring gap clearance with a flat feeler gauge. \_\_\_\_\_  
 What is the reject measurement? \_\_\_\_\_  
 Use an inside micrometer or telescoping gauge to measure cylinder taper. \_\_\_\_\_ (one inch from top)  
 \_\_\_\_\_ (one inch from bottom)
29. Report the general condition of the piston. \_\_\_\_\_
30. Report the general condition of cylinder walls. \_\_\_\_\_  
 \_\_\_\_\_
31. Report the cylinder bore and stroke, according to specifications.  
 Bore \_\_\_\_\_ Stroke \_\_\_\_\_
32. Determine the engines displacement in cubic inches.  

$$\frac{(\text{Bore})^2}{4} \times 3.14 \times \text{Stroke} = \underline{\hspace{2cm}}$$
33. There are several repairs and jobs that can be done to the engine before assembly.
- Clean the head and cylinder.
  - Emery sand the magnet on the flywheel.
  - Clean and gap the spark plug (unless a new one will be purchased).
  - Clean every part, inspect all gaskets.
  - Grind the valve face.
  - Re-finish the valve seats.
  - Grease the spin wheel on the starter.

- h. Inspect and clean fuel system and air cleaner.
  - i. List new parts needed and their cost.
34. Write and sketch the correct torque and sequence to tighten the head bolts.
35. What is the proper torque on the connecting rod bolts? \_\_\_\_\_
- \*\*\*\*\*Be sure to use oil when putting each part back together.
36. Replace all parts and gaskets which do not meet specifications.
37. Reassemble engine in reverse procedure of disassembly.
38. Start and tune engine.
39. Briefly describe the condition and any special operating instructions the owner should follow since the engine overhaul.

225

JOB SHEET 3

TWO-CYCLE ENGINE OVERHAUL

OBJECTIVES:

1. To develop the ability to trouble-shoot a two-cycle engine.
2. To develop the ability to correctly disassemble, repair, and reassemble a two-cycle engine.

MATERIALS:

1. Used two-cycle engine
2. Mechanics' tools
3. Service and repair manual

PROCEDURE:

Select a suitable work station, a two-cycle engine, and the necessary mechanics' tools. Be sure you have financing available to replace necessary parts. Observe all shop safety rules!!

Follow all directions

1. Engine Manufacturer \_\_\_\_\_  
Serial Number \_\_\_\_\_  
Model Number \_\_\_\_\_  
Type Number \_\_\_\_\_
2. Do a compression test by giving the flywheel a quick spin. Does the flywheel rebound sharply? \_\_\_\_\_
3. Check the crankshaft end play. \_\_\_\_\_  
What is the recommended range? \_\_\_\_\_
4. What is the condition of the spark plug? \_\_\_\_\_  
Is there a spark? \_\_\_\_\_
5. Draw a sketch of the governor linkage in respect to the carburetor and the governor system. (Use reference manual if necessary.)

6. Remove the following parts and inspect them for excessive wear. Remember the position of each part. (Note, all engines may not require removal of all these parts.)

A. Air cleaner

E. Gas tank

B. Spark plug

F. Governor linkage

C. Muffler

G. Engine shroud

D. Carburetor

H. Flywheel screen

7. Using a flat feeler gauge, measure and report the armature air-gap clearance. \_\_\_\_\_ Check service manual for manufacturers' recommendation. \_\_\_\_\_

8. Remove flywheel.

9. What is the condition of the flywheel key? \_\_\_\_\_

What is the purpose of having a soft key in the crankshaft groove?  
\_\_\_\_\_

10. Remove the breaker-point cover.

11. Make a sketch of the ignition system. Include armature and coil unit, breaker points, condenser, spark plug, wiring.

LABEL ALL PARTS

227

12. Inspect all ignition parts for wear.
13. Check the breaker point gap with a feeler gauge. \_\_\_\_\_ What is the manufacturers' recommended setting? \_\_\_\_\_
14. Check the spark plug gap with a feeler gauge. \_\_\_\_\_ What is the manufacturers' recommended setting? \_\_\_\_\_
15. Briefly describe the general condition of the ignition system.
  
16. Remove cylinder head and gasket.
17. Make a sketch of the head and the location of head bolts which have various lengths.
  
18. Briefly describe the condition of the cylinder head area and gasket. Is there any evidence of compression leakage?
  
19. Inspect the reed plate, crankcase gaskets, and main bearing seals for pressure leakage.
20. Remove crankcase cover plate.
21. Mark the connecting rod cap and connecting rod. Unbolt the connecting rod cap and use plastigage to measure the clearance. \_\_\_\_\_  
What is the manufacturers' recommended clearance. \_\_\_\_\_
22. If needed use a ridge reamer tool to remove the ridge at the top of the cylinder.
23. Remove piston and connecting rod.
24. Remove the crankshaft. Measure and report the crankpin size. \_\_\_\_\_  
What is the manufacturers' reject size? \_\_\_\_\_

25. Measure and report the size of crankshaft journals.

Magneto journal \_\_\_\_\_

PTO journal \_\_\_\_\_

26. What are the manufacturers' reject sizes of the crankshaft journals?

Magneto journal \_\_\_\_\_

PTO journal \_\_\_\_\_

27. How many rings does this engine have? \_\_\_\_\_ Name them.

28. CAREFULLY.... remove the top ring from the piston. Place it about one inch down into the cylinder. Use piston to square the ring in the cylinder. Measure the ring gap end clearance with a fiat feeler gauge. \_\_\_\_\_ What is the manufacturers' reject gap clearance?  
\_\_\_\_\_

29. Use an inch micrometer or telescoping gauge to measure cylinder taper.

\_\_\_\_\_ (one inch from top)

\_\_\_\_\_ (one inch from bottom)

30. Inspect and report the general condition of the piston. \_\_\_\_\_

31. Inspect and report the general condition of the cylinder wall.  
a. Diameter? \_\_\_\_\_ b. Out-of-roundness? \_\_\_\_\_

32. Report the cylinder bore and stroke. Use manual to locate specifications.

Bore \_\_\_\_\_ Stroke \_\_\_\_\_

33. Determine the engine displacement in cubic inches.

$$\frac{(\text{Bore})^2}{4} \times 3.14 \times \text{Stroke} =$$

34. There are several repairs and jobs that can be done to the engine before assembly.

- a. Clean the head and cylinder.
- b. Emery sand the magnet on the flywheel.
- c. Clean and gap the spark plug (unless a new one will be purchased).
- d. Clean every part, inspect gaskets.
- e. Grind valve face.
- f. Re-finish valve seats.



- g. Grease the spin wheel on the starter.
- h. Inspect and clean fuel system and air cleaner.
- i. List all new parts needed and their cost.

35. Write and sketch the torque sequence to tighten the head bolts.

36. What is the proper torque on the connecting rod bolts? \_\_\_\_\_  
Head bolts? \_\_\_\_\_

\*\*\*\* Be sure to use oil when putting each part back together.

37. Replace all parts and gaskets which do not meet specifications.

38. Reassemble engine in reverse procedure of disassembly.

39. Start and tune engine.

40. Briefly describe the condition of the engine and any special operating instructions the owner should follow since the engine overhaul.

JOB SHEET #4  
PREPARING SMALL ENGINES  
FOR END-OF-SEASON STORAGE

I. OBJECTIVE:

To be able to properly prepare small engines for off-season storage.

II. MATERIALS NEEDED:

- A. Mechanics tools (socket set, wrenches, screwdrivers)
- B. Oil squirt can
- C. Catch pan for used oil
- D. Clean shop rags.
- E. Pressurized air.

III. PROCEDURE:

- A. Drain fuel tank and start engine to remove excess fuel from carburetor system.
- B. If engine is to be stored in a damp, cold location, close the valve on the fuel line (if one is used) and refill the tank with fuel. This will prevent the tank from rusting. This fuel should be discarded before starting the engine at the beginning of the next season.
- C. Clean the engine to remove all dirt and oil on the outside of the engine and under the shroud.
- D. Remove the spark plug and squirt about  $\frac{1}{2}$  to 1 teaspoon of oil into cylinder. Rotate the crankshaft three or four times to coat the cylinder with oil. Replace spark plug.
- E. Drain and refill engine crankcase on four-cycle motor.
- F. Service and clean air cleaner.
- G. Apply paint, oil, or grease to exposed unpainted surfaces to prevent rusting.
- H. Cover engine with plastic and store inside building where it is not in contact with the ground.
- I. Complete the information and check the service jobs performed.

MOWER INFORMATION

Name of Owner _____	Address _____
Make of Mower _____	Date of Service _____
Engine Make _____	Model _____
Serial No. _____	Type _____

SERVICE REPORT

- \_\_\_ 1. Clean engine and mower thoroughly.
- \_\_\_ 2. Check ignition system.
  - a. Test spark intensity
  - b. Clean and regap plug
  - c. Inspect and gap points
  - d. Check ignition wires
  - e. Check flywheel shear key
- \_\_\_ 3. Check compression.
- \_\_\_ 4. Service air cleaner.
- \_\_\_ 5. Drain sediment bowl, carburetor, fuel tank.
- \_\_\_ 6. Drain and change crankcase oil (4-cycle engine).
- \_\_\_ 7. Clean exhaust ports (2-cycle engine).
- \_\_\_ 8. Protect cylinder with teaspoon of clean oil poured in spark plug hole.
- \_\_\_ 9. Check for general condition -- loose nuts or screws, leaks, cracked or broken parts and repair if necessary.
- \_\_\_ 10. Sharpen blade (rotary mower).
- \_\_\_ 11. Report need for repair or replacement of parts.
- \_\_\_ 12. Check and clean undercarriage of mower.

I V. QUESTIONS:

A. What type and weight of oil should be used with small engines  
for summer use? \_\_\_\_\_  
for winter use? \_\_\_\_\_

B. How often should oil be changed in four-cycle engines?  
\_\_\_\_\_  
\_\_\_\_\_

C. If an engine will not start how would you proceed to determine  
the cause?  
\_\_\_\_\_  
\_\_\_\_\_

V. OBSERVATIONS: How can these skills be used to improve your  
S.O.E.P.?

TEACHER'S KEY

STUDENT WORKSHEET 1

SMALL ENGINE-OPERATION, TROUBLE SHOOTING AND TUNEUP

1. Four- stroke cycle engines make two revolution(s) of the crankshaft for each power stroke of the piston.
2. On the intake stroke, the intake valve opens while the exhaust valve remains closed .
3. During the compression and power stroke both valves are closed .
4. On the exhaust stroke, the exhaust valve opens while the intake valve remains closed .
5. Two-stroke cycle engines make one revolution(s) of the crankshaft for each power stroke of the piston.
6. The intake valve of many two- cycle engines is a reed type which opens only one way. Other two-cycle engines may have a rotary valve which is timed to open when the piston starts moving on the compression stroke.
7. The four- cycle engine may be subject to slightly less trouble in starting and will operate more smoothly at slow speeds.
8. Two- cycle engines produce more power per unit of weight since there is a power stroke every revolution of the crankshaft.
9. The four distinct strokes for one complete cycle are intake , compression , power , and exhaust .
10. Three primary essentials for the operation of any internal combustion engine are compression , carburetion , and ignition .
11. The true sealing of piston and cylinder walls is done by piston rings .
12. Upper rings are solid and called compression rings and the bottom ring is perforated and is called an oil ring .
13. Piston displacement refers to the space displaced by the piston in its travel.
14. Piston displacement =  $\frac{(\text{Bore})^2}{4} \times 3.14 \times \text{Stroke}$
15. The piston displacement for an engine with a 3-inch bore and 3-inch stroke is 21.2 cubic inches .

16. A comparison between the volume of the cylinder when the piston is at the bottom of its stroke and the volume of the cylinder when it is at the top of its stroke is called the compression ratio.
17. At high speeds each valve must open and close in 1/50 of a second or less.
18. List the 6 parts of the valve system.

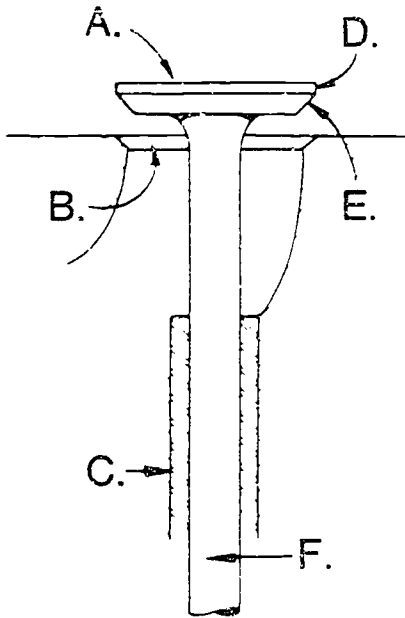

- A. Head
- B. Seat
- C. Valve Guide
- D. Margin
- E. Face
- F. Stem

19. The functions of the carburetor system are to atomize fuel, mix fuel and air, vaporize mixture, and deliver mixture to cylinders.
20. The parts of the carburetion system include the air inlet, carburetor, fuel tank and intake ports.
21. The three types of carburetion systems are float, suction, and diaphragm.
22. The restricted section of the air passage is called the venturi. Its purpose is to increase the velocity of air.
23. Two common types of governors are the air-vane and centrifugal.

24. Most carburetors have a second jet which opens into the air passage just above the butterfly when it is in the closed position. This is called the idle jet.
25. Starting a cold engine requires a richer fuel mixture, this is accomplished by closing the choke.
26. Three types of air cleaners used on small engines are oil bath, oil saturated, and dry element.
27. Small engines generally have a magneto as the source of energy to produce electric spark.
28. Many small engine magnetos are of the flywheel type.
29. The ends of the primary coil windings are connected to the breaker points and the ends of the secondary coil windings are connected to the spark plug.
30. In small engines, the points are normally open and a spark occurs once every revolution of the crankshaft.
31. Most small engines are air cooled rather than liquid cooled.
32. The flywheel provides the small engine with a fan for cooling.
33. The three types of lubrication systems found in four-cycle engines are dipper splash, oil slinger, and oil pump.
34. Low compression in small engine is generally the result of worn piston rings or valves.
35. If compression is satisfactory, the next check is the carburetion.
36. If flooding has occurred without an abnormal amount of choking the engine, you may suspect a plugger air cleaner.
37. Spark plug gaps are checked with a wire gauge.
38. Oil on the points is a common source of ignition-system trouble in small engines.
39. When adjusting the carburetor during the final tuneup, set the idle speed adjustment first, then the main fuel jet.

TEACHER'S KEY  
STUDENT WORKSHEET 2  
THE TWO-CYCLE ENGINE

1. The two-cycle engine takes two strokes of the piston to go through one cycle. It has no camshaft , valve springs , or valve lifters .
2. The two-cycle engine uses its crankcase as a fuel mixture transfer pump.
3. The charging of the crankcase, compression of the fuel charge and ignition must occur on the upward stroke, where as exhaust and intake occurs on the downward stroke.
4. The two types of valves used on two-cycle engines are reed and rotary .
5. Lubrication of a two-cycle engine depends on addition of oil to the fuel .
6. The use of regular grade gasoline is recommended for two-cycle engines.
7. A carburetor consists of four parts:
  - a. air passage to combustion chamber.
  - b. fuel opening into carburetor.
  - c. constant source of fuel.
  - d. an orifice (restriction) in fuel passage line.
8. A pound of fuel requires 15 pounds of air to burn properly.
9. Identify the carburetor parts.

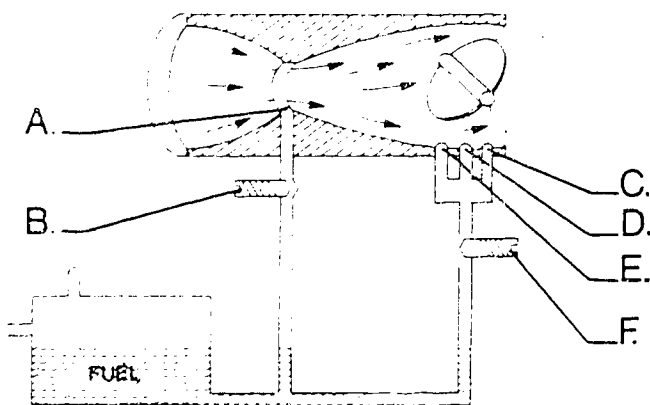



10. The choke provides an exceedingly rich mixture when starting cold engines.
11. While float type carburetors can be used on two-cycle engines, chain saws usually require the diaphragm type carburetor.
12. The diaphragm type carburetor can be used in any position.
13. The inlet valve can be either a ball or needle type.
14. Chain saw engines make use of crankcase pulsation pressures to pump fuel into the carburetor.
15. Because of dirt, chain saw engines are provided with both fuel and air filters.
16. Both magnets and battery powered ignition systems require a spark plug, breaker points, condensor, and coil.
17. The inner or primary winding of the coil contains a few feet of wire, where as the outer or secondary winding contains many feet of very fine wire.
18. The breaker points are two small circular pads of tungsten.
19. The condensor is used to absorb surges of electricity across the points.
20. The width of a sparkplug gap is very important.
21. The spark plug fires when the breaker points open.
22. When an engine doesn't run or put out full power, check ignition, carburetion and compression.
23. Check the ignition by unscrewing the spark plug and grounding it by holding the threaded part of the plug to the engine's bare metal.
24. Most carburetor troubles are caused by improper adjustment of the main and idle adjustment needles.
25. Explain how to check if the combustion chamber is receiving fuel.  
Hold thumb over spark plug hole and pull starter rope.

26. Check engine compression by pulling the starter rope, then slackening the rope and noting the amount of engine re-bound .
27. A compression gauge should indicate at least 90 pounds of pressure for adequate engine operation.
28. The nine items which should be checked on the ignition system are:
- spark plug
  - breaker points
  - loose or shorted wiring
  - flywheel-armature gap
  - ignition switch
  - condensor
  - coil
  - magnet
  - flywheel key
29. The six items which should be checked on the fuel system are:
- main fuel needle
  - idle adjustment needle
  - fuel inlet valves
  - fuel pump
  - fuel filters
  - air filters
30. The four things which should be checked for loss of power are:
- poor compression
  - dirty or plugged muffler
  - over heating
  - valve clearance
31. Preignition is:  
Combustion caused before spark plug is timed to fire.

32. Detonation is:

Combustion caused by glowing carbon particles or by hot spots in the combustion chamber.

TEACHER'S KEY

WORKSHEET 3

SMALL ENGINE PART IDENTIFICATION

1. Identify the following parts on the four-cycle small engine.

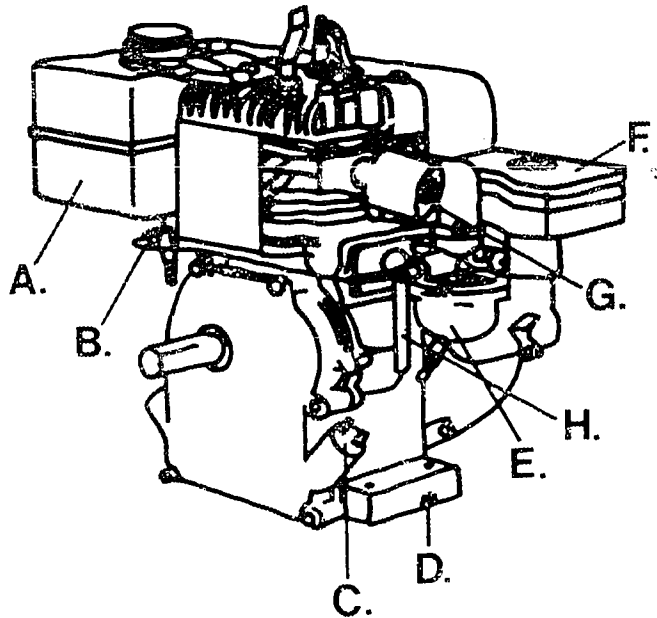

A. Fuel tank

B. Sediment bowl

C. Oil filler plug

D. Oil drain plug

E. Carburetor

F. Air breather

G. Muffler

H. Crankcase breather

2. Identify the following types of carburetors.

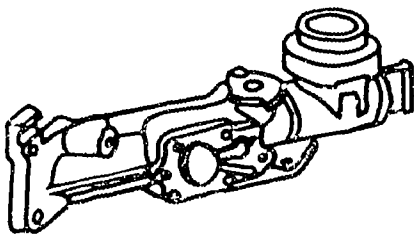

A. Diaphragm

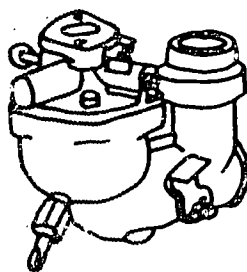

B. Float

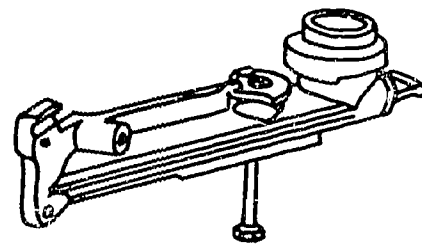

C. Suction-lift

3. Identify the following parts of the carburetor.

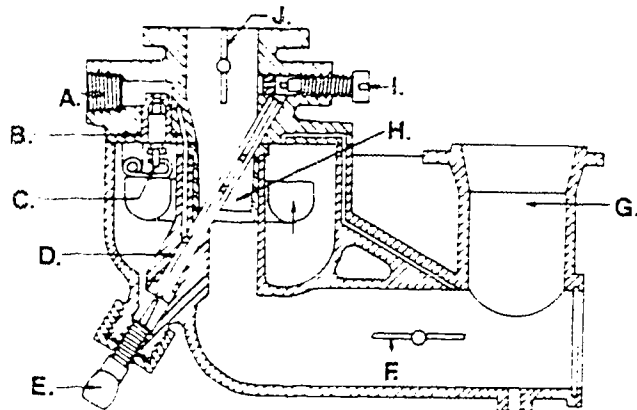

- |                             |                          |
|-----------------------------|--------------------------|
| A. <u>Fuel inlet</u>        | F. <u>Choke valve</u>    |
| B. <u>Float needle seat</u> | G. <u>Air horn</u>       |
| C. <u>Float</u>             | H. <u>Venturi</u>        |
| D. <u>Fuel nozzle</u>       | I. <u>Idle valve</u>     |
| E. <u>Main needle valve</u> | J. <u>Throttle valve</u> |

4. Identify the following parts of the cut-away engine.

- |                                     |
|-------------------------------------|
| A. <u>Piston</u>                    |
| B. <u>Crankcase (cylinder wall)</u> |
| C. <u>Connecting rod</u>            |
| D. <u>Crankshaft</u>                |
| E. <u>Camshaft</u>                  |
| F. <u>Cam lobe</u>                  |
| G. <u>Valve tappet</u>              |
| H. <u>Valve spring</u>              |
| I. <u>Valves</u>                    |
| J. <u>Sparkplug</u>                 |
| K. <u>High tension lead</u>         |

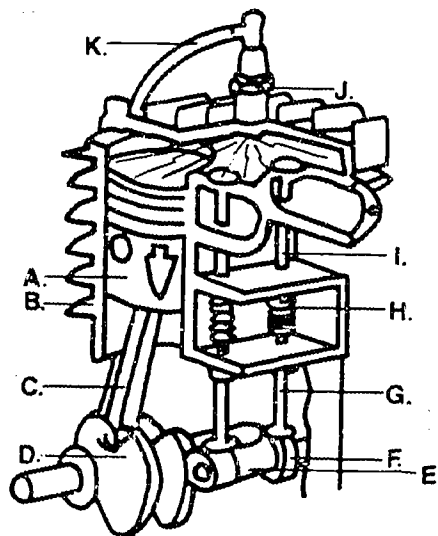

5. Identify the following parts of the small engine magneto ignition system.

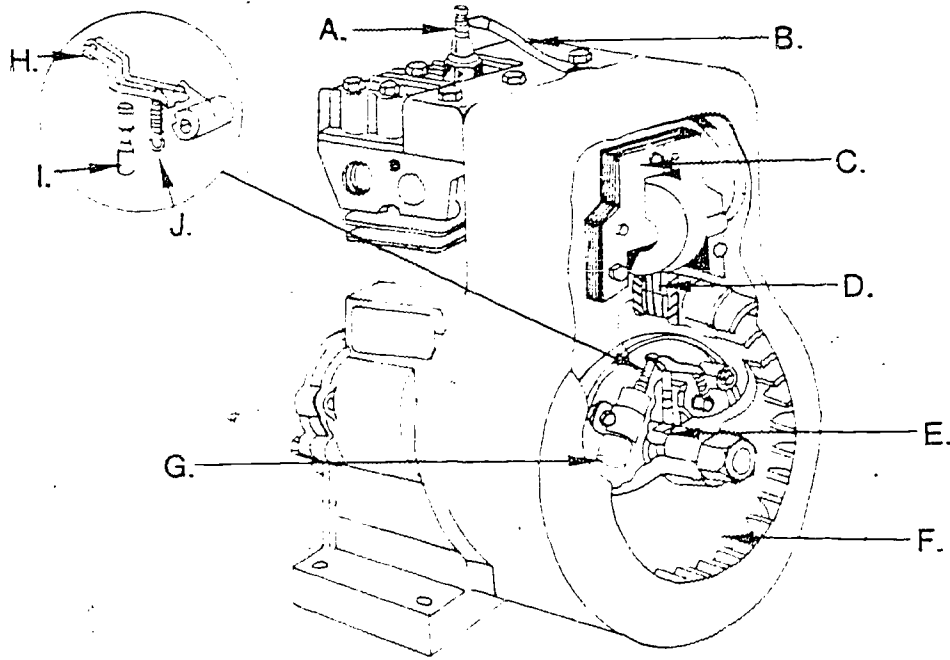

- A. Spark plug
- B. High tension lead
- C. Armature
- D. Magnet
- E. Plunger flat
- F. Flywheel
- G. Condensor
- H. Ignition point
- I. Plunger
- J. Point spring

215

TEACHER'S KEY

WORKSHEET 4

TOOLS AND EQUIPMENT FOR SMALL ENGINE OVERHAUL

1. A shop-made flywheel holder will fit a variety of engines.
2. A special flywheel holder wrench is used to take off recoil mechanism starters.
3. A flywheel puller is used to remove flywheels.
4. A valve spring compressor is used to control valve springs when removing and replacing valves.
5. A piston ring expander is used for removing and replacing piston rings.
6. A piston ring compressor is used for replacing pistons in the cylinder.
7. The two types of thickness gauges are flat type and wire type.
8. Outside micrometers are used to measure pistons, bearings, and other external parts.
9. Telescoping gauges are used for measuring holes or slats.
10. A micrometer measures engine parts for wear and dimensions.
11. The torque wrench can measure the amount of twisting force applied to bolts.
12. A ridge reamer can be used to remove the carbon ridge at the top of cylinder walls.
13. You should use a cylinder hone to deglaze cylinder walls before new piston rings are installed.
14. The piston ring gap can be checked with a flat feeler gauge.
15. The device used to reface valves and valve seats is a valve grinder.
16. Three types of valve repair tools are valve grinder, valve seat grinder, and valve lapper.
17. The dial indicator measures crankshaft end play and out of roundness.
18. A compression gauge checks the engine compression.

19. Rejact gauges are used to check bearings, valve guides , and breaker point plungers .

20. Explain how to use plastigage.

Place small strip on connecting rod cap. Tighten cap on crankshaft to correct torque. Remove and measure Plastigage spread.

21. Identify the following small engine tools.

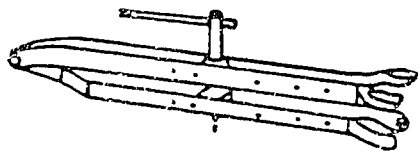

A. valve spring compressor

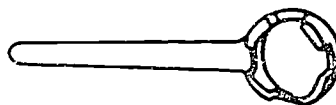

B. starter clutch wrench



C. flywheel holder

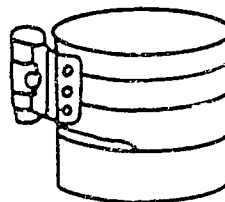

D. piston ring compressor





E. flywheel puller



F. torque wrench

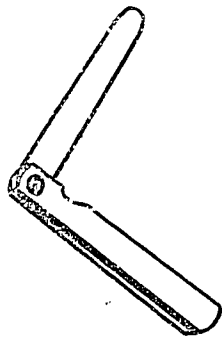

G. feeler gauge

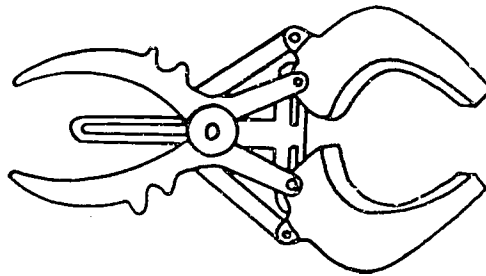

H. piston ring expander

TEACHER'S KEY  
STUDENT WORKSHEET 5  
SMALL ENGINES - REPAIR AND OVERHAUL

A. DISASSEMBLING THE ENGINE

1. Before taking the engine apart, clean it thoroughly.
2. Drain the oil and gas from the engine.
3. The eight things which should be removed when disassembling the engine are:
  - a. air cleaner
  - b. carburetor
  - c. fuel tank
  - d. flywheel
  - e. head
  - f. crankcase
  - g. piston
  - h. valves

B. MEASURING CYLINDER, PISTON AND RING WEAR

1. It is important first to determine the type and amount of wear in the cylinder.
2. Use a telescoping gauge to measure piston diameter.
3. Explain how to measure the cylinder for out-of-round.  
Measure diameter at right angles near the top, middle, and bottom.
4. Explain how to measure the cylinder taper.  
Measure diameter near top and bottom and subtract measurements.
5. Two common reasons for rejecting a piston are:
  - a. excessive ring groove wear
  - b. excessive piston skirt clearance.

6. Piston ring end gap should be measured for each compression ring and oil ring.

#### C. CHECKING CRANKSPIN AND BEARING

1. The crankspin should be checked for three things: scoring, wear, and out-of-roundness.
2. A convenient way to measure bearing clearance is to use a plastic thread (Plastigage).

#### D. REPLACING THE PISTON

1. Before replacing the piston you should clean the cylinder wall thoroughly.
2. Clean piston ring grooves.
3. Use a ring expander to install rings on the piston.
4. The piston of a two cycle engine may have a small pin or knob in each ring groove to keep the ring from turning.
5. Explain how to install the piston in the cylinder.
  - a. Oil cylinder walls and piston.
  - b. Align ring gaps 120 degrees apart.
  - c. Compress rings.
  - d. Slide piston into cylinder.

#### E. SERVICING THE VALVES

1. The four things which should be serviced on the valves are:
  - a. valve face
  - b. valve seat
  - c. stem clearance
  - d. tappet clearance

#### F. REPLACING THE ENGINE HEAD

1. Use a torque wrench when tightening the engine head to specifications.
2. Alternately tighten the bolts on one side and the other so that the head is drawn down evenly.

#### G. REPAIRING THE CARBURETOR AND FUEL SYSTEM

1. The two types of carburetors that should be serviced are the float type and diaphragm type.

## H. SERVICING THE IGNITION SYSTEM

1. If the breaker points are pitted or burned they should be replaced.
2. Inspect the spark plug for oil deposits, wide gap , or burning .
3. The three kinds of spark to look for when testing the coil and ignition wiring are weak spark , inconsistent spark, and bright blue spark .
4. Magneto air gap is the distance between rotating magnets in the flywheel and the stationary laminations of the coil.
5. The two types of coil and armature are outside the flywheel and inside the flywheel.
6. Specified magneto output should jump a gap of .166 inch .

## I. OPERATING AND CHECKING THE ENGINE

1. Explain the things which should be installed or adjusted before starting the engine. (Refer to repair manual for specific procedures.)

2. Explain how to set the main and idle screw with the engine running. (Refer to operator for specific engine.)

J. READ THE FOLLOWING STATEMENTS ON SAFETY AND PLACE AN "A" BY THOSE STATEMENTS WHICH WOULD BE GOOD "APPROVED PRACTICES" TO OBSERVE.

- A   1. Storing gasoline in approved metal containers.
- A   2. Removing gasoline from the gas tank and carburetor before repairing an engine.
- 3. Refilling a gasoline tank with the engine running.
- A   4. Working in a well-ventilated shop.
- A   5. Using an approved solvent for cleaning engine parts.
- A   6. Removing the spark plug wire before servicing or repairing an engine.
- A   7. Having dry chemical fire extinguishers available.
- A   8. Following good work habits.
- A   9. Reading and following your operator's and/or service manual.
- A   10. Cleaning the engine before it is serviced.
- 11. Using gasoline for cleaning engine parts.
- 12. Working on a hot engine.
- A   13. Storing greasy shop rags in a metal air-tight container.
- A   14. Cleaning wrenches and other tools before storing.
- A   15. Securing the engine in an approved mount before starting to work on the engine.
- 16. Operating the engine with the governor disconnected.
- A   17. Operating a vertical shaft engine with a special flywheel when adjusting the governor and carburetor.
- 18. Test-running the engine without the engine shroud which covers the flywheel.
- 19. Handling volatile fuels in a shop or area which has an open flame.
- A   20. Removing all fuel from an engine before placing it in dry storage.
- 21. To operate an engine which has gasoline dripping from the fuel system.

- 22. Operating an engine with the muffler removed.
- 23. Assembling the engine using all bolts and cap screws of the specified grade.
- 24. Using a starter rope which is not frayed.
- 25. Using "either type" starter fluids to start small engines.
- 26. Using a torch to repair leaks in a gasoline tank.
- 27. Operating a vertical shaft lawn mower with a cracked or bent blade.
- 28. Spilling gasoline on a hot engine.
- 29. Wearing safety glasses when in the shop.
- 30. Using an approved flywheel holder when removing a flywheel nut.
- 31. Keep hands and face away from carburetors when cranking an engine if the air cleaner is removed.

# OPERATION OF THE FOUR-STROKE CYCLE ENGINE

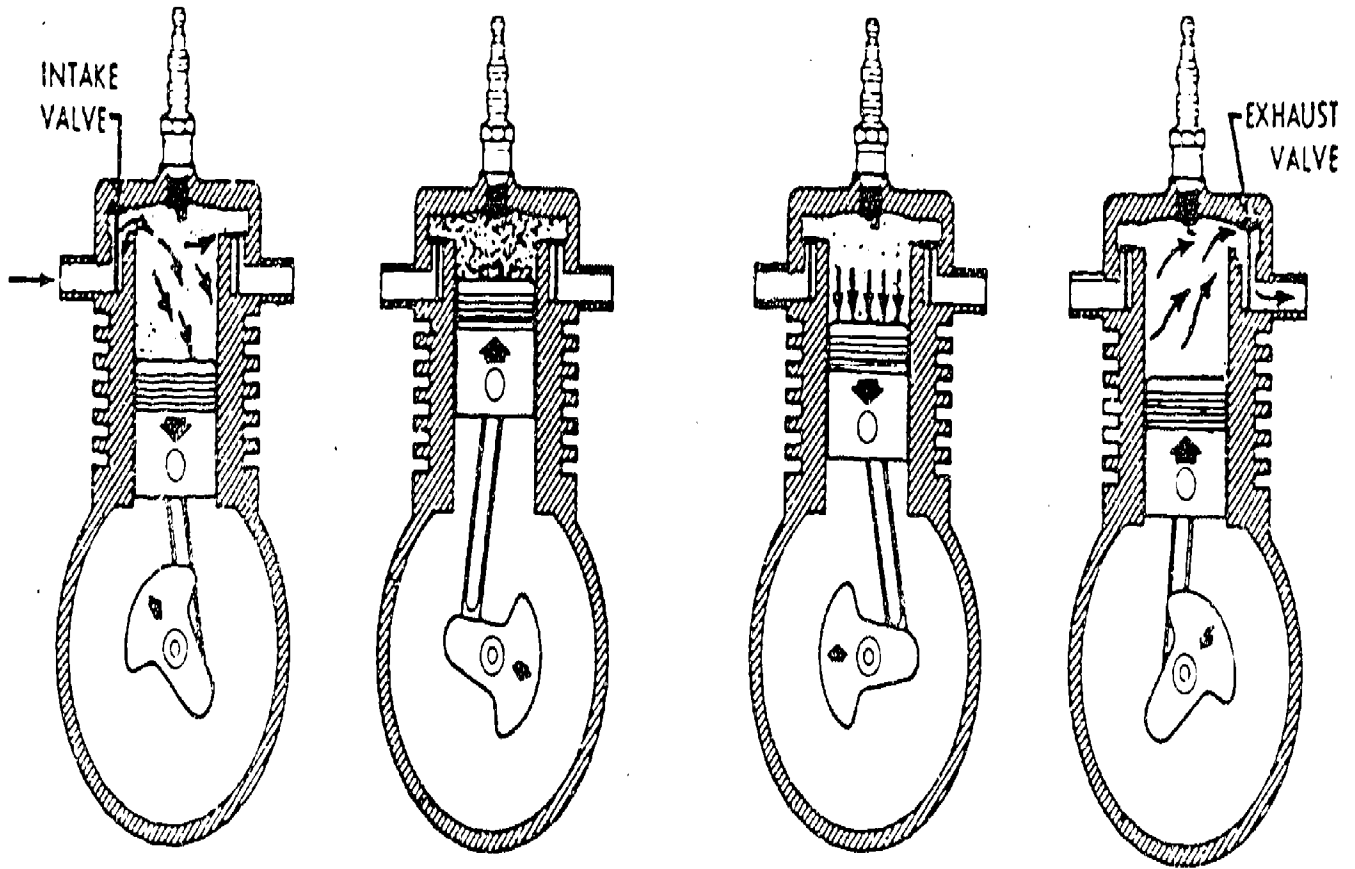

A. INTAKE  
STROKE

B. COMPRESSION  
STROKE

C. POWER  
STROKE

D. EXHAUST  
STROKE

# OPERATION OF THE TWO-STROKE CYCLE ENGINE

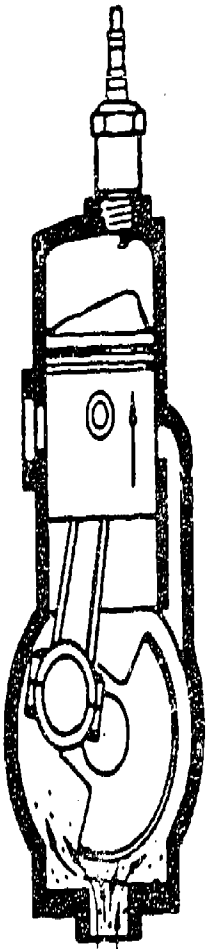

INTAKE

Fig. 1

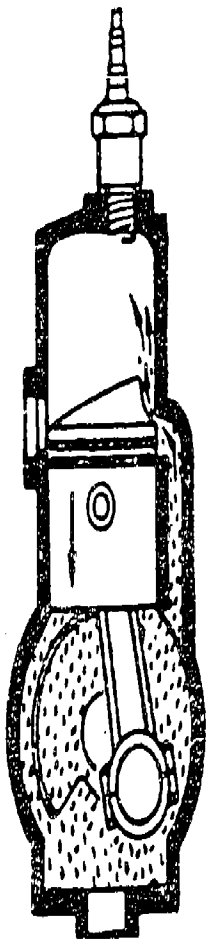
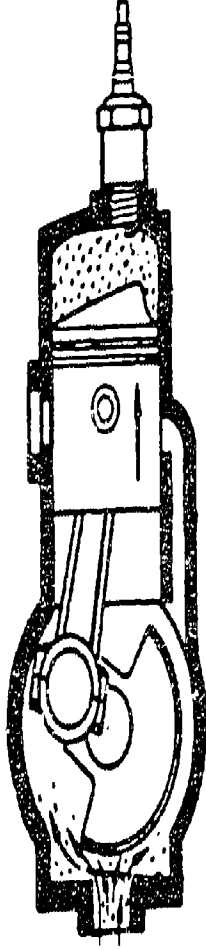
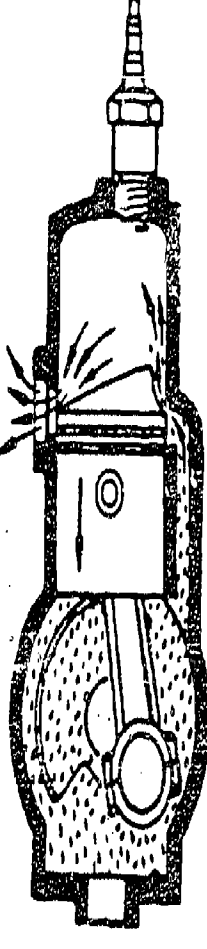
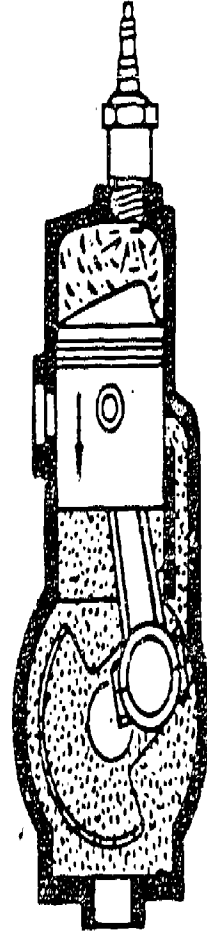

Fig. 2



COMPRESSION POWER

Fig. 3



EXHAUST

Fig. 5



# PISTON DISPLACEMENT

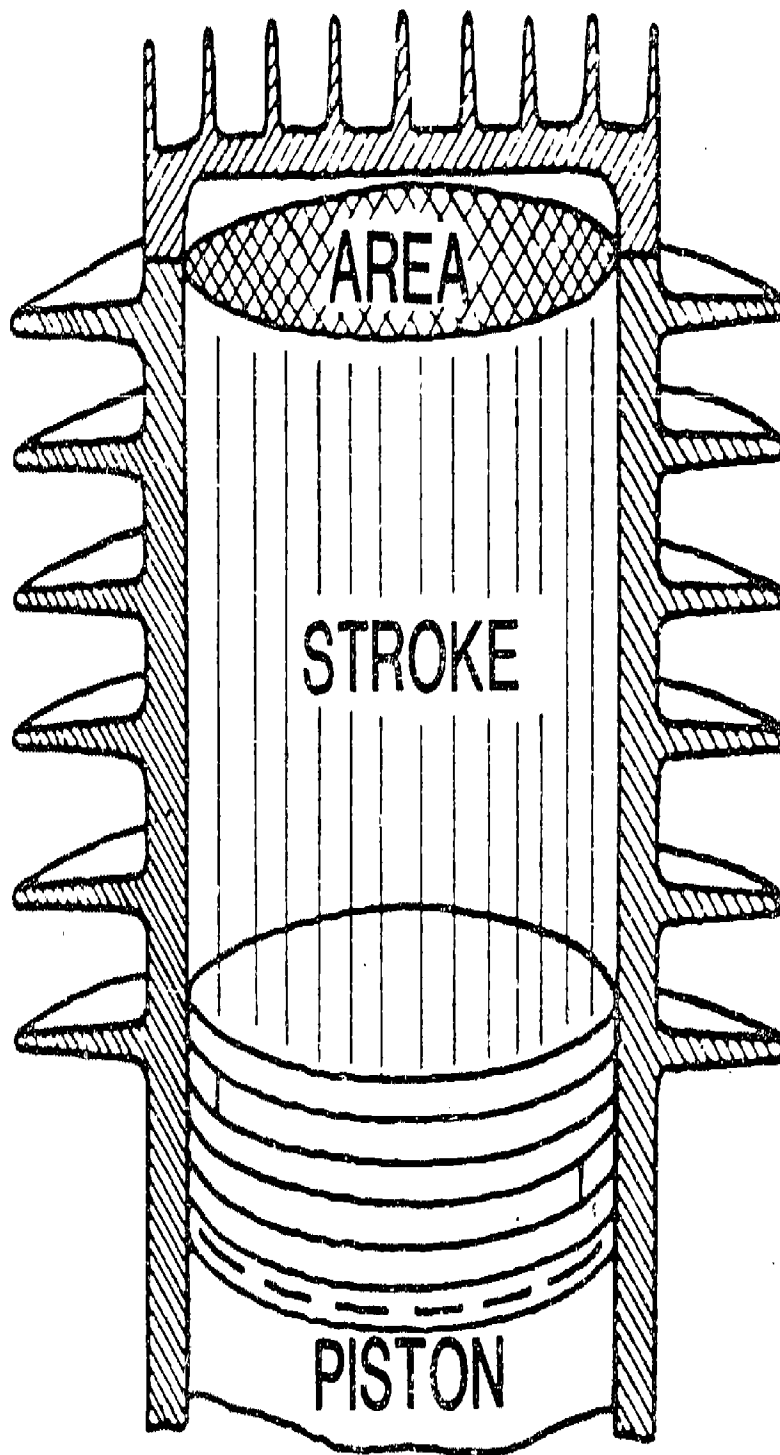

$$\text{PISTON DISPLACEMENT} = \frac{(\text{BORE})^2}{4} \times 3.1416 \times \text{Stroke}$$

# VALVE PARTS NAMED

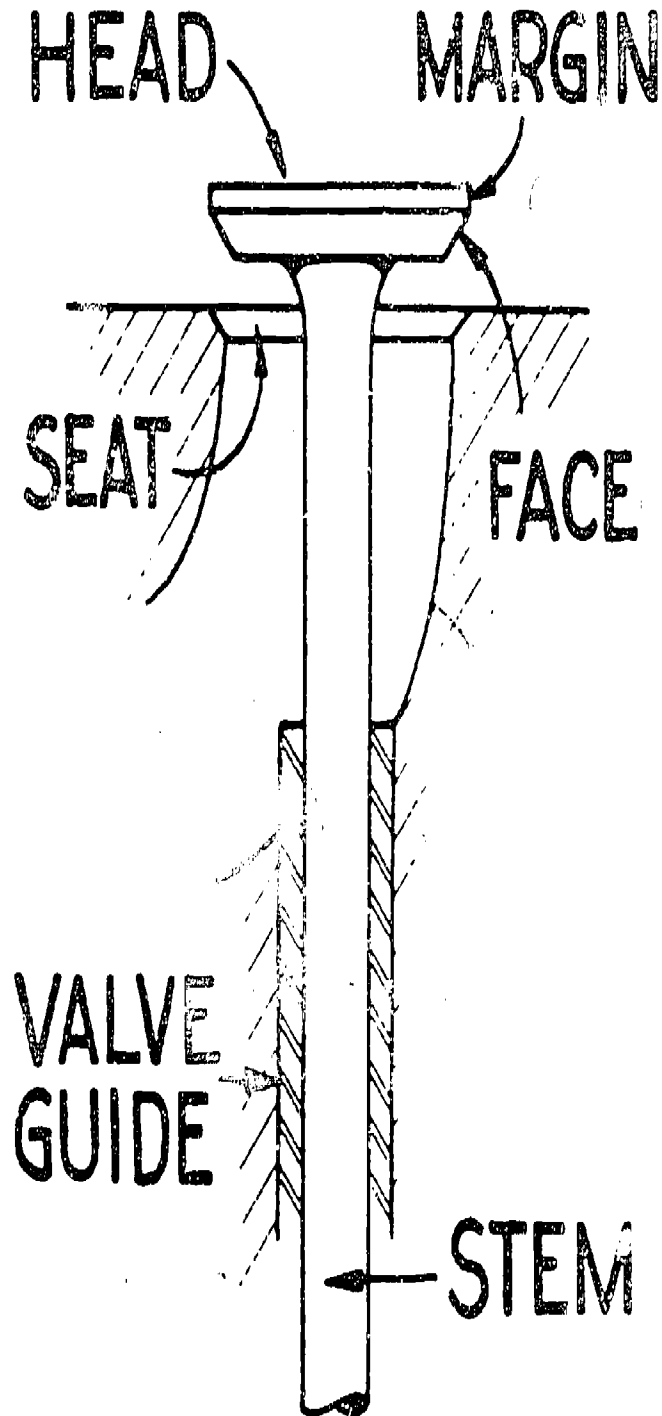

# PARTS OF MAGNETO IGNITION SYSTEM

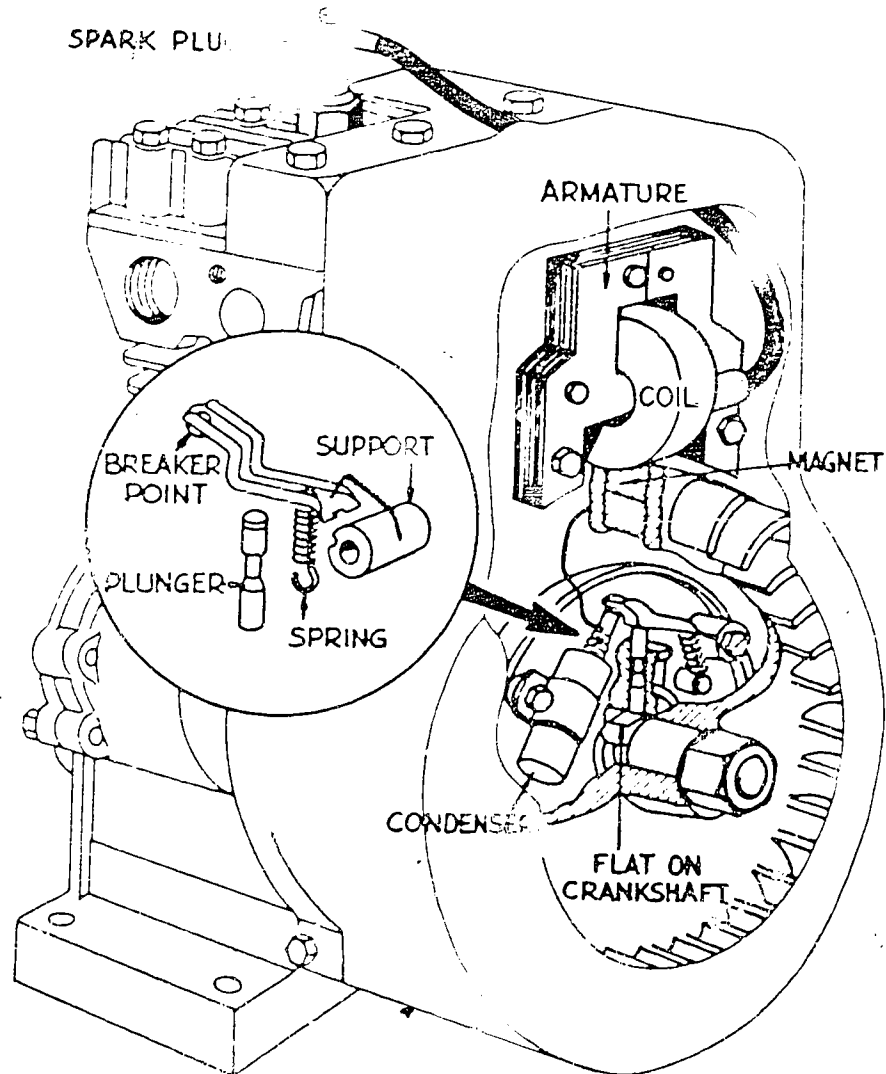

# FLYWHEEL TYPE MAGNETO

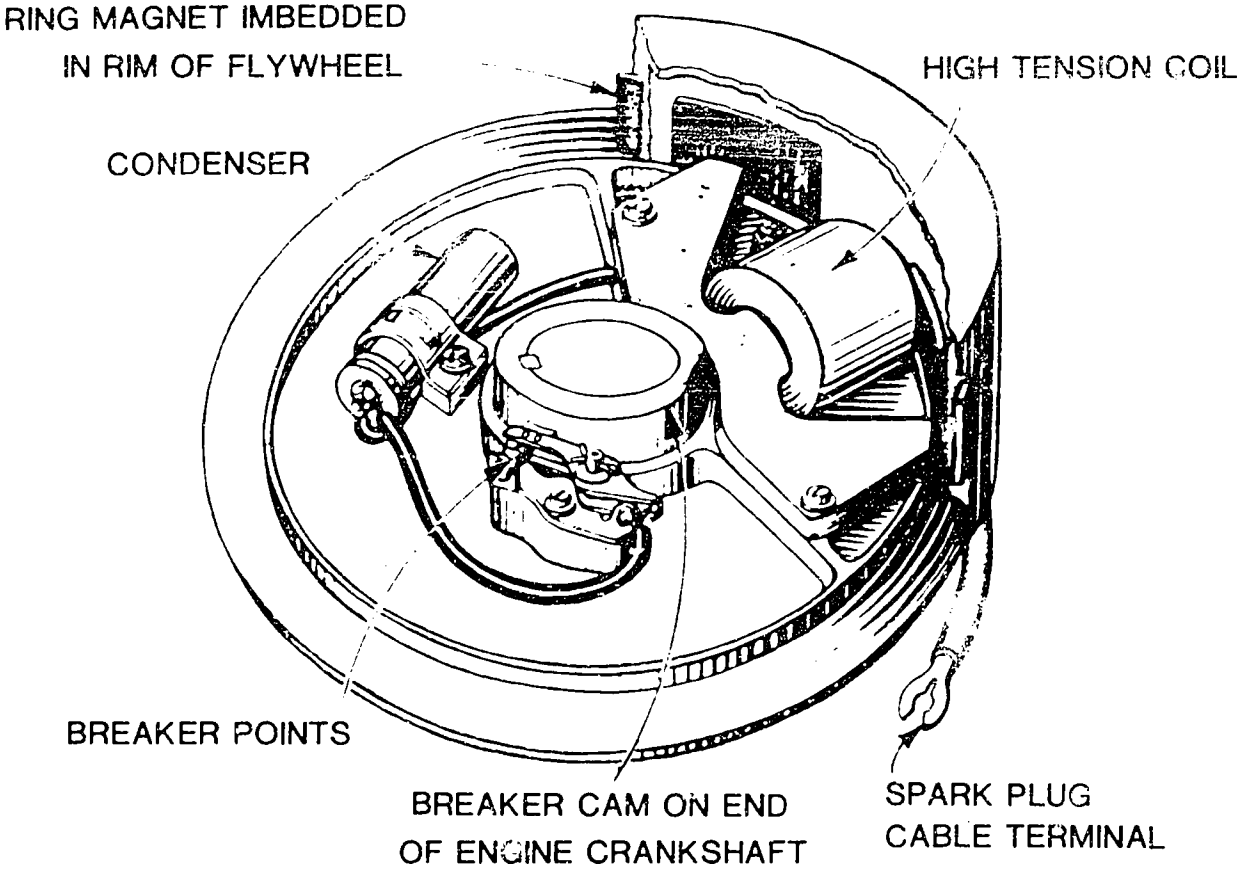

# MAGNETO IGNITION OPERATION 1

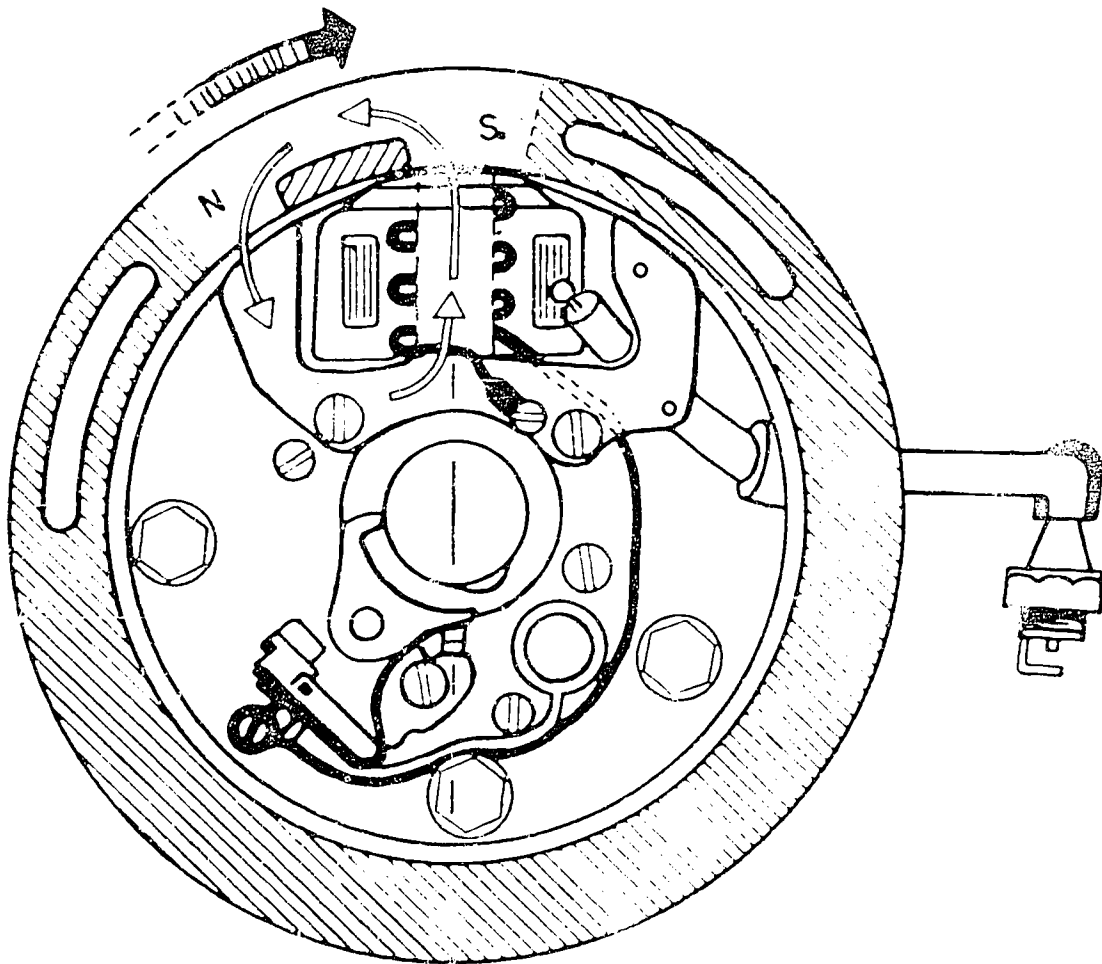

# MAGNETO IGNITION OPERATION 2

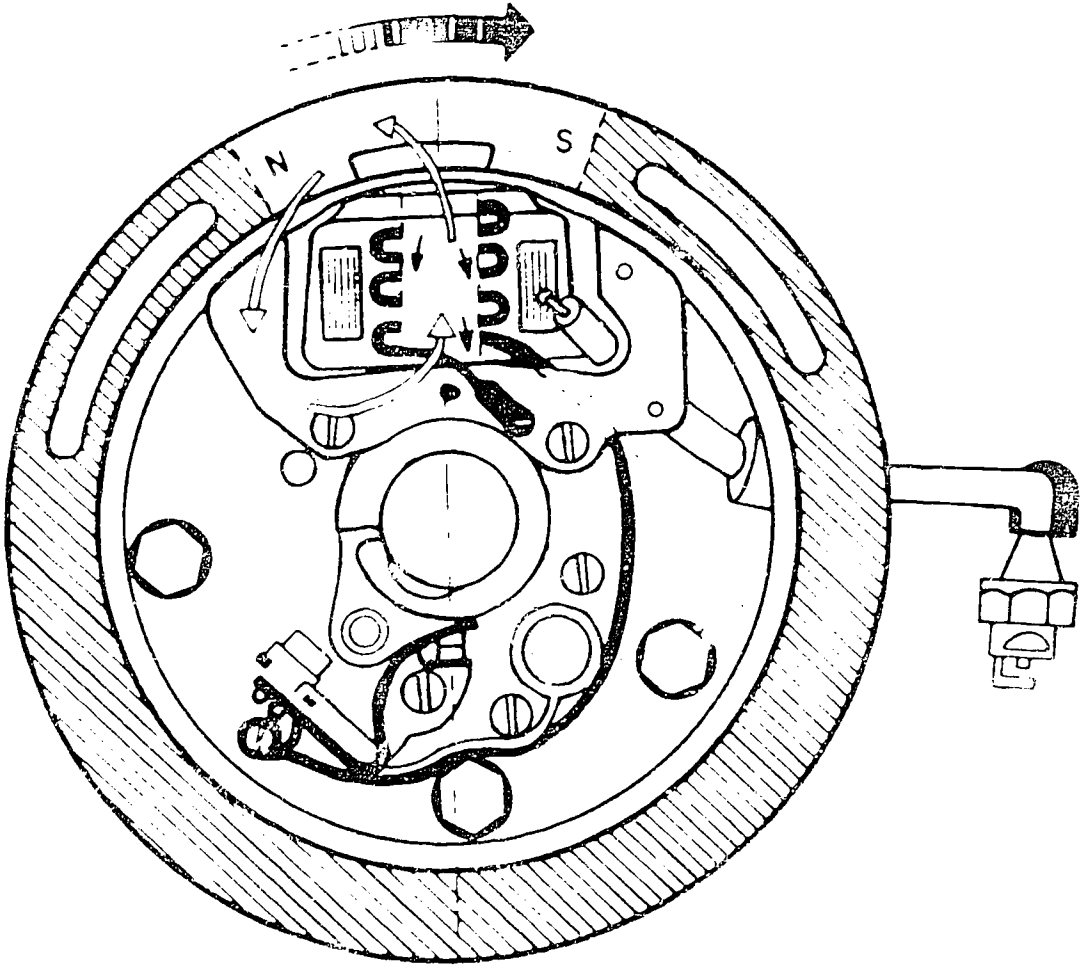

POINTS ABOUT TO OPEN

# MAGNETO IGNITION OPERATION 3

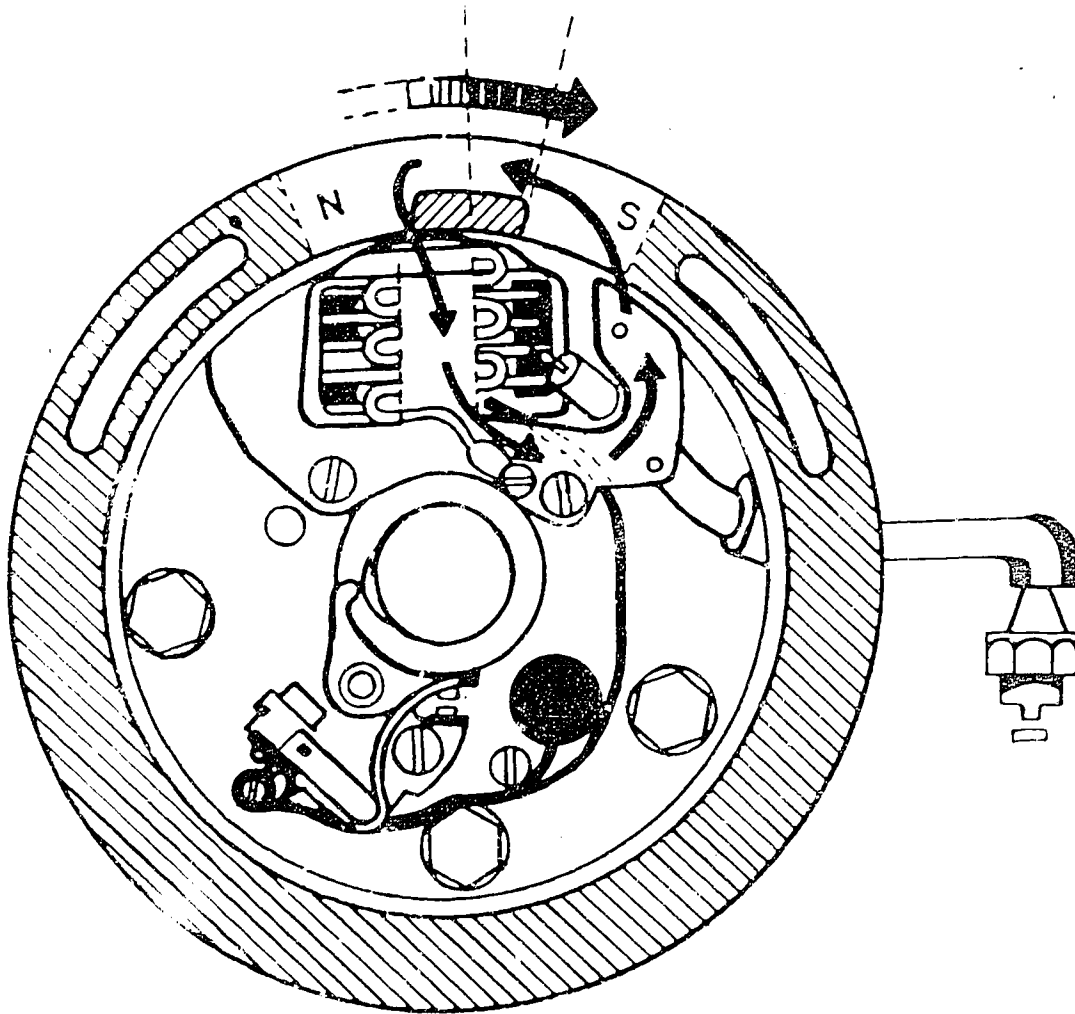

POINTS OPEN

# PARTS of SOLID STATE IGNITION SYSTEM

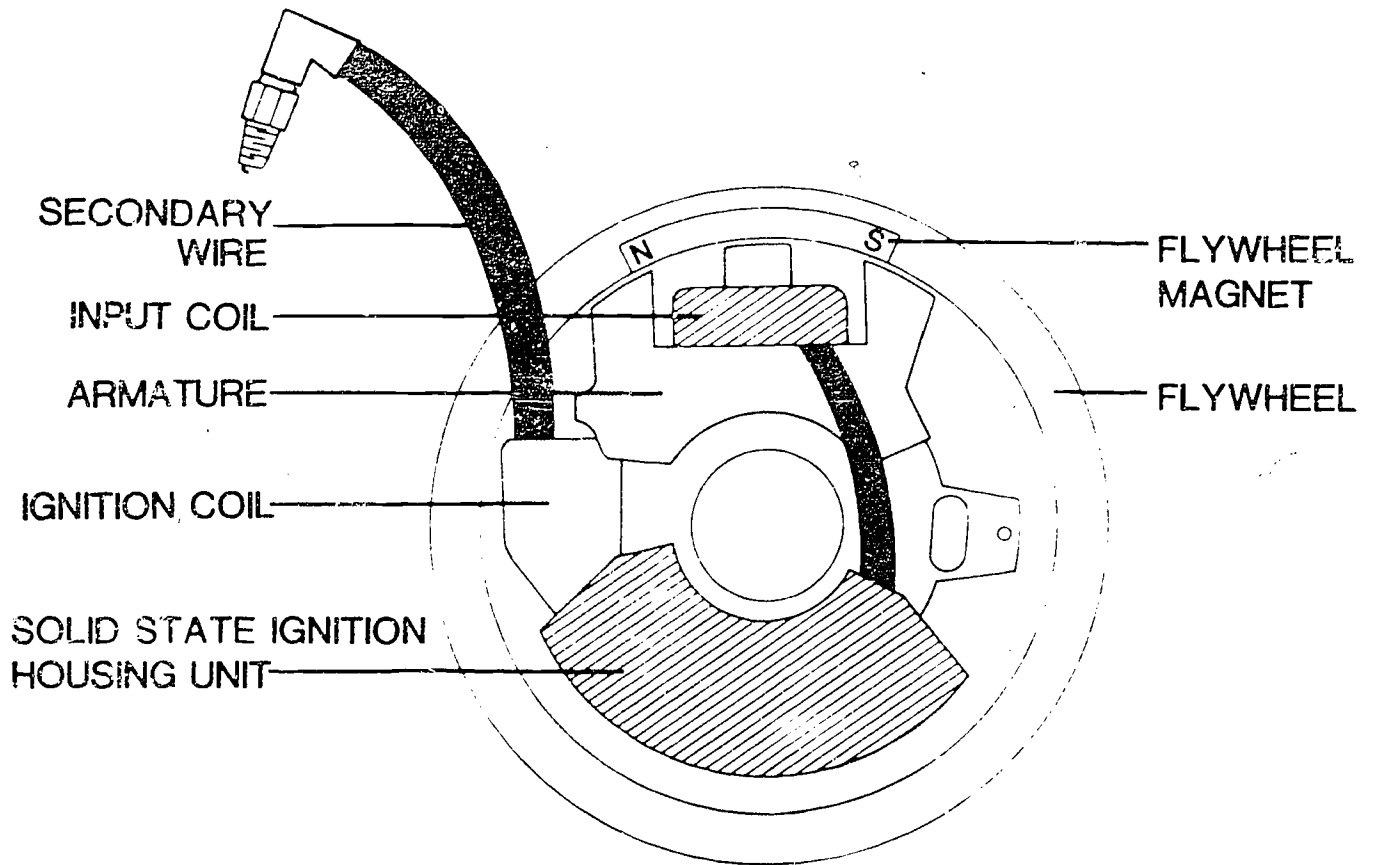

285

III-H-4-74



# PARTS of SOLID STATE IGNITION SYSTEM

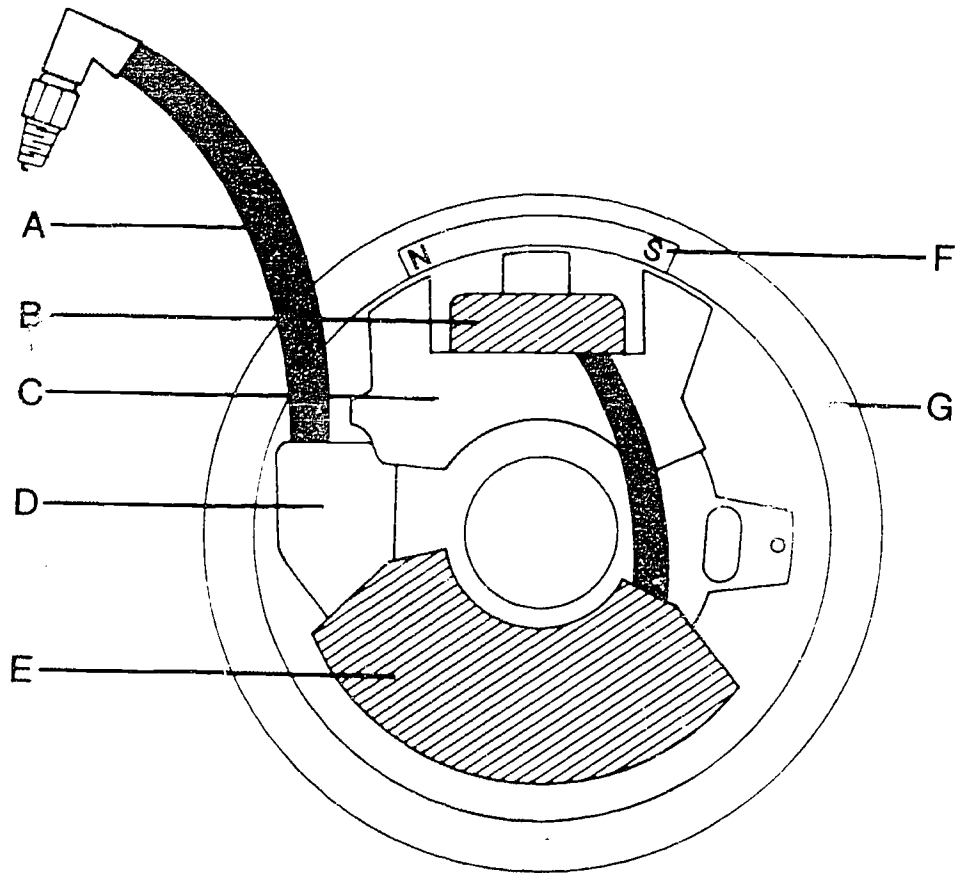

# SOLID STATE IGNITION OPERATION 1

Electrical current is developed at the input coil.

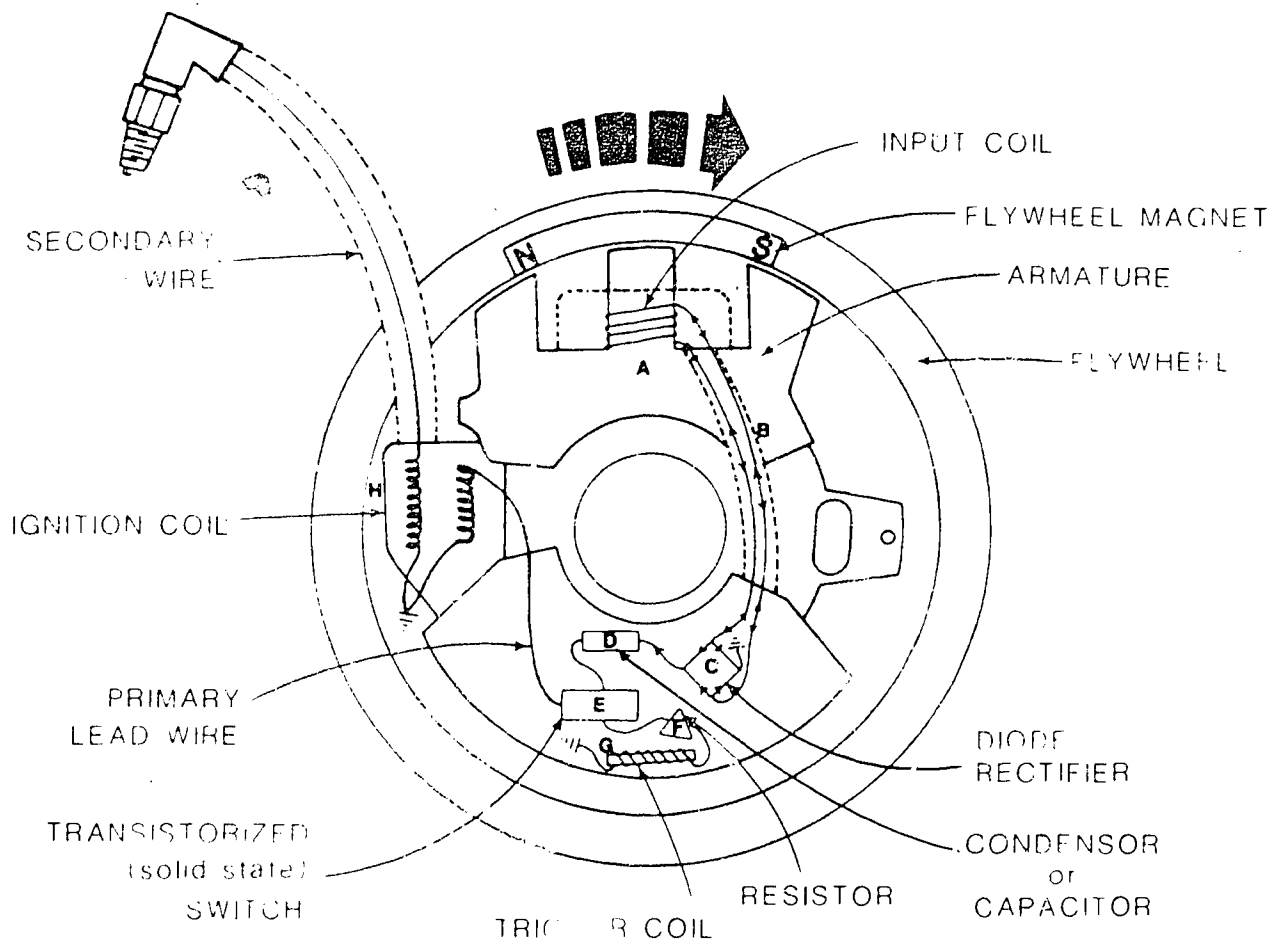

287

III-H-4-76

# SOLID STATE IGNITION OPERATION 2

Electrical charge is stored in the condenser.

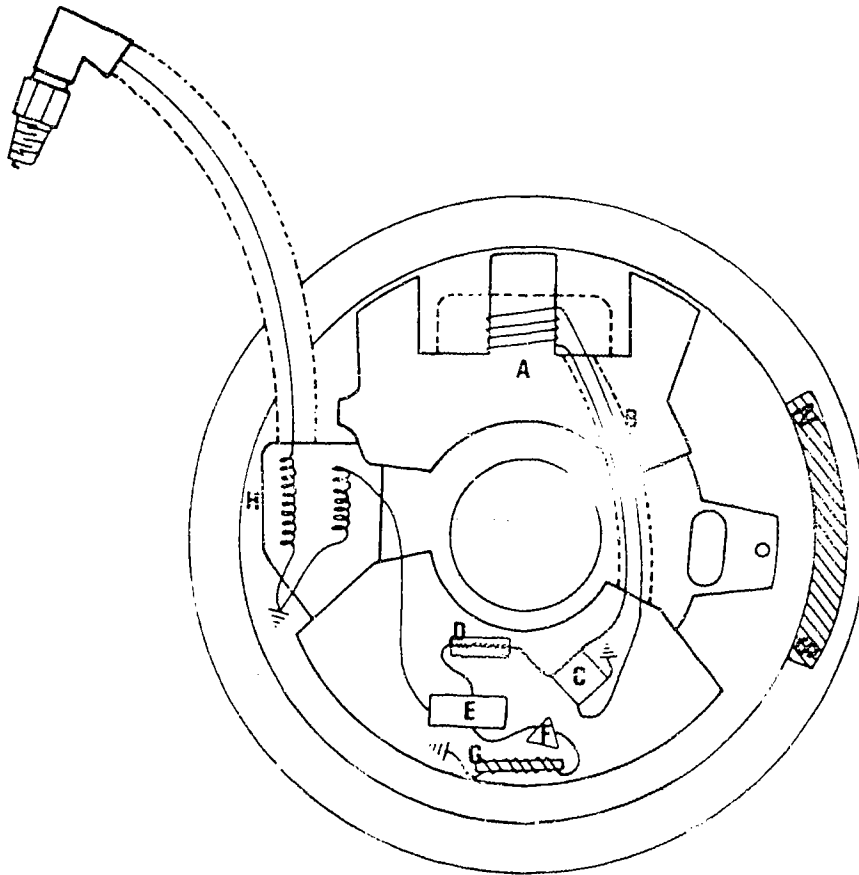

# SOLID STATE IGNITION OPERATION 3

The switch opens and electrical current moves to the ignition coil and spark occurs at the spark plug.

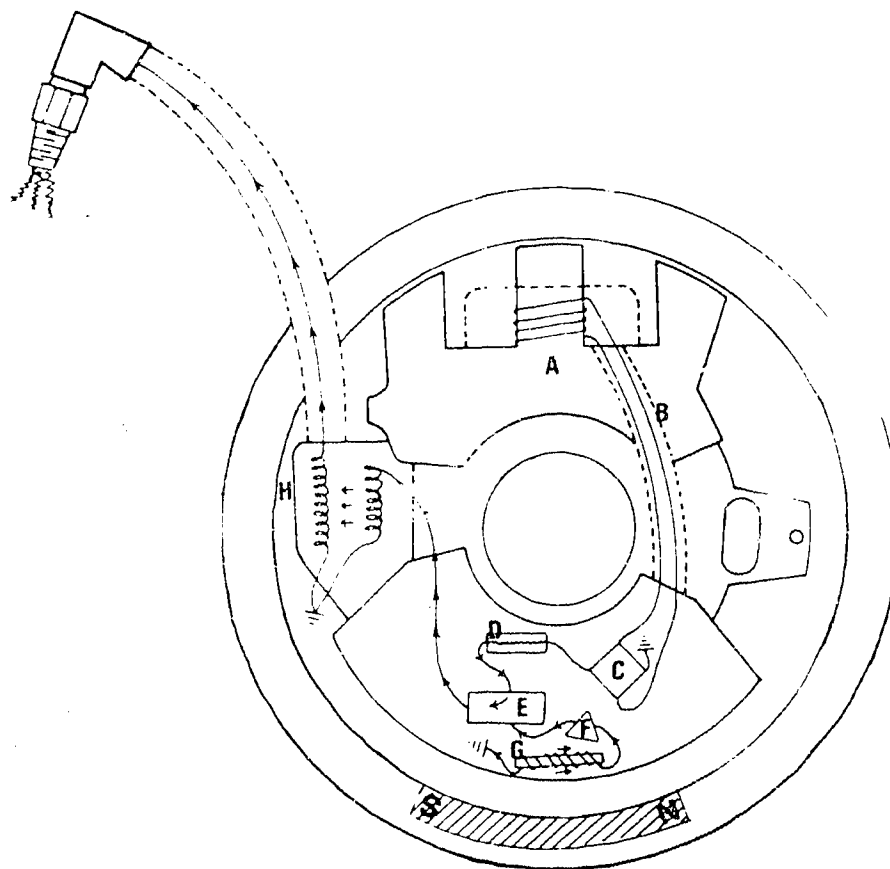

265

III-H-4-78

# FUEL SUPPLY SYSTEMS ON FOUR-CYCLE ENGINES

1. Gravity system

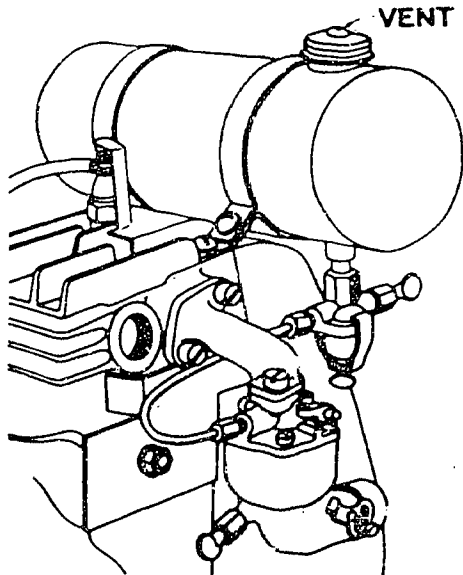

2. Pump system

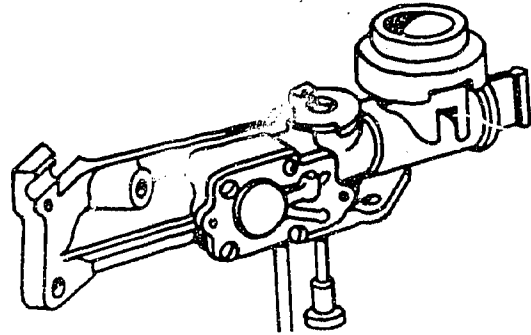

3. Suction system

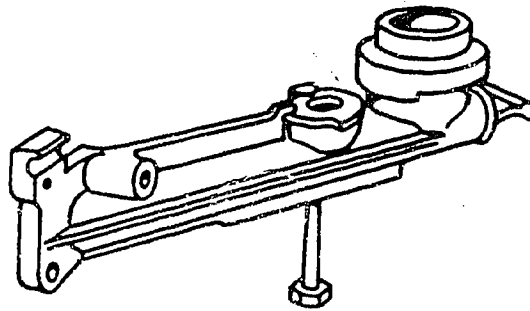

# CARBURETOR SYSTEM ON TWO-CYCLE ENGINES

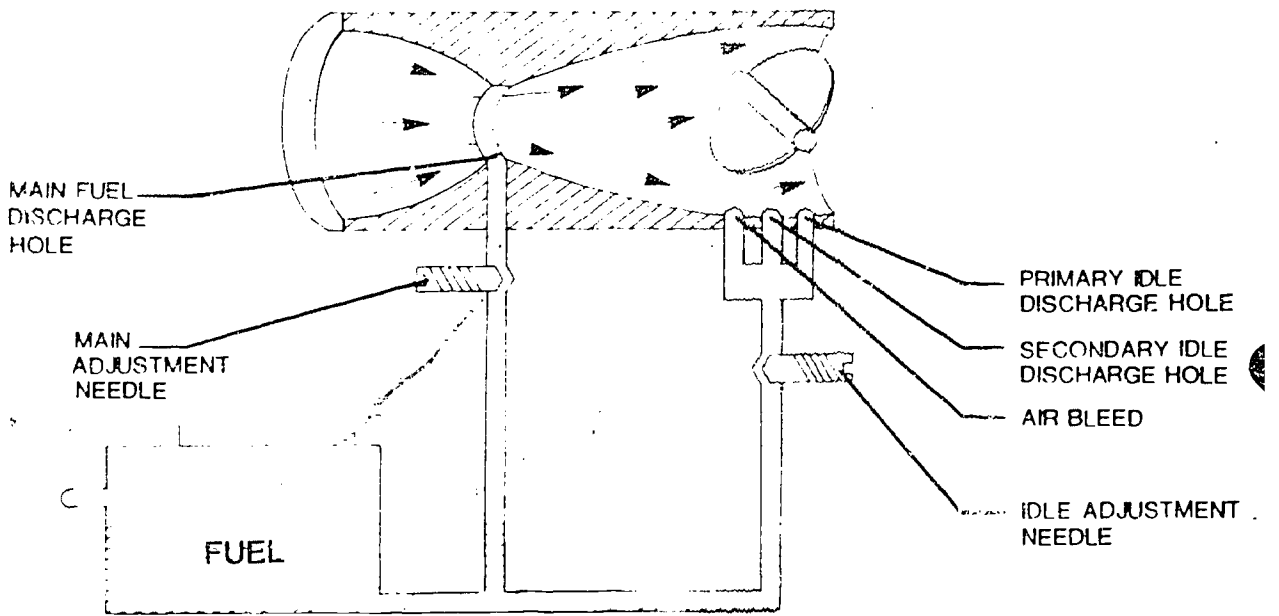

272

# CARBURETOR SYSTEM ON TWO-CYCLE ENGINES

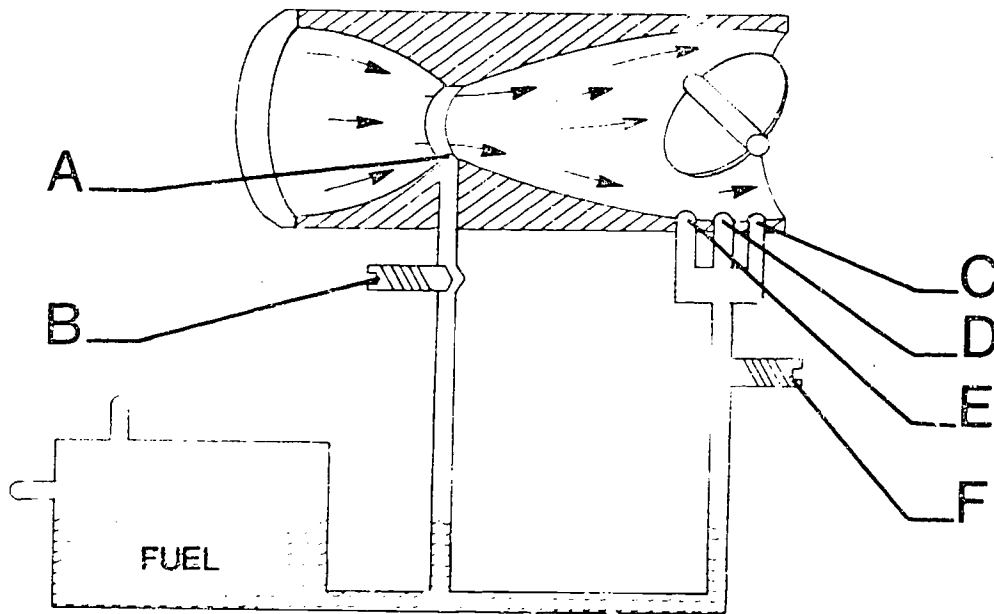

## TRANSPARENCY DISCUSSION GUIDE

### MAINTAINING AND REPAIRING SMALL ENGINES

- I. Transparencies - OPERATION OF THE FOUR-STROKE CYCLE ENGINE and OPERATION OF THE TWO-STROKE CYCLE ENGINE
  - A. Define and explain the events that take place during each stroke on a four-cycle and two-cycle engine.
  - B. Discuss the sequenced events that make up a complete cycle.
- II. Transparency - PISTON DISPLACEMENT
  - A. Explain how displacement is a measure of the quantity of fuel-air mixture that can be taken into the cylinder on the intake stroke.
  - B. Use the formula on the transparency to show how displacement is computed in cubic inches.
  - C. Point out how changing the bore and/or stroke or the shape of the piston top can change the displacement.
- III. Transparency - VALVE PARTS NAMED
  - A. Use this transparency to supplement the information in the worksheets.
  - B. Point out the function of the valves and what should be looked for when inspecting each part of the valve during overhaul.
  - C. Have students examine various valves and determine if they are usable or should be replaced.
  - D. Have students practice grinding or lapping used valves.
- IV. Transparencies - PARTS OF MAGNETO IGNITION SYSTEM and FLYWHEEL TYPE MAGNETO
  - A. Use these transparencies to supplement the information needed in the worksheets.
  - B. Point out the various parts of the magneto ignition system.
  - C. Explain and discuss the functions of each part in providing electrical current to the spark plug at the proper time.
- V. Transparency - MAGNETO IGNITION OPERATION I
  - A. Point out the position of the flywheel magnet in relation to the coil and armature.



- B. Discuss the relationship between a magnetic field and an electric current. The magnetic field builds up as the magnets pass closer to the coil.
- C. As the magnetic field is built up, with the points closed, a small electrical current will develop in the primary windings of the coil.

VI. Transparency - MAGNETO IGNITION OPERATION II

- A. Point out the clockwise movement of the flywheel magnet.
- B. Note that the magnetic flow is starting to move through the center leg and right-hand leg of the armature.
- C. This movement reverses the direction of flow through the center leg.
- D. The ignition points are still closed and the result of the magnetic field starting to reverse develops a strong voltage in the primary windings of the coil.

VII. Transparency - MAGNETO IGNITION OPERATION III

- A. At the peak flow of the primary current the ignition points open and break the circuit.
- B. There is a surge of current due to the break in the primary circuit which is absorbed by the condenser so the points do not arc as they start to open.
- C. This rapid collapse of the magnetic field cuts through the secondary windings in the coil.
- D. This induces a very high voltage in the secondary windings which in turn results in current jumping the gap at the spark plug electrodes.
- E. Point out the importance of a good flywheel key in relation to ignition timing of these events.

VIII. Transparency - PARTS OF THE SOLID STATE IGNITION SYSTEM

- A. Use this transparency to introduce the parts of the solid state ignition system used on some newer small engines.
- B. Point out how this system is similar to the magneto system. It has a magnet in the flywheel, coil and armature to generate a low voltage current. It has an ignition coil to generate a high voltage current at the spark plug.
- C. Point out that this system does not use ignition points to time the spark, but uses a third coil and a solid state ignition switch which is transistorized to set off the high voltage spark

at the plug. These items are contained in the solid state ignition housing unit.

IX. Transparency - SOLID STATE IGNITION OPERATION I

- A. Point out that current is developed in the input coil (A) as the magnetic field from the flywheel magnet passes near the armature at (A).
- B. This movement of the flywheel magnet establishes a weak alternating current (B).
- C. The alternating current passes a diode rectifier (C) which converts the alternating current to direct current.
- D. The direct current flows from the diode rectifier (C) to the condenser (D) where it is stored briefly.

X. Transparency - SOLID STATE IGNITION OPERATION II

- A. Point out that the flywheel has rotated and the magnet is no longer near the input coil.
- B. The electrical current is now stored in the capacitor waiting on the solid state switch to open (E).

XI. Transparency - SOLID STATE IGNITION OPERATION III

- A. Point out that the flywheel has rotated so the flywheel magnet is near the trigger coil (F).
- B. The lines of the magnetic field cut through the trigger coil (F) which induce a low voltage current.
- C. This low voltage current passes through a resistor (G) and enters the solid state switch (E) which is transistorized.
- D. The solid state switch (E) opens when it receives the current from the trigger coil (F).
- E. This opening of the switch allows the current which is stored in the capacitor (D) to flow to the ignition coil (H).
- F. As the current enters the primary windings of the ignition coil (H) a large voltage is induced into the secondary windings and a spark occurs at the electrodes of spark plug.
- G. Note the importance of having the flywheel magnets properly timed so maximum voltage is produced and the spark will occur at the proper time in combustion chamber.
- H. One advantage of the solid state ignition system is that there are no moving parts rubbing against one another.

- I. Another advantage is that there are no ignition points to burn up.
- J. Have the students identify other advantages of the solid state ignition system over the magneto ignition system.
- K. Have the students identify some disadvantages of the solid state ignition system on small engines.

XII. Transparencies - FUEL SUPPLY SYSTEMS ON FOUR-CYCLE ENGINES and CARBURETOR SYSTEM ON TWO-CYCLE ENGINES

- A. Point out the basic parts of each type of carburetor used on four-cycle engines.
- B. Discuss the location of the fuel tank on each system and how the fuel moves from the tank to the carburetors.
- C. Discuss the operation of the carburetor system used on some two-cycle engines.
- D. Point out how the suction is developed on two-cycle and four-cycle engines.
- E. Point out where the fuel goes when it leaves the carburetor of the two-cycle engines.

TEACHER'S KEY  
SAMPLE TEST QUESTIONS

SMALL ENGINE REPAIR AND OVERHAUL

TRUE OR FALSE

- F 1. The two-stroke cycle engine makes two revolutions for each power stroke.
- F 2. On the compression stroke of a four-stroke cycle engine only the intake valve is closed.
- T 3. On the power stroke of a four-stroke cycle engine both valves remain closed.
- F 4. The crankcase of the two-stroke cycle engine is sealed and filled with lubricating oil at the factory.
- T 5. With both the two-stroke and four-stroke engines, the spark ignites the air-fuel mixture when the piston is near the top of the cylinder.
- T 6. The crankcase of a two-stroke cycle engine is part of the fuel intake system.
- F 7. When cleaning a micrometer, it is best to use compressed air to remove dust and dirt.
- T 8. In a gravity feed fuel system, the gas tank is above the carburetor.
- T 9. Air speed in the horn of the carburetor is increased by reducing the size of the opening.
- T 10. Small engines have their ignition timed properly by having the breaker points open at the correct time.
- T 11. Small engines should be kept clean as dirt on the outside of the engine can cause the engine to overheat.
- T 12. A fundamental principle of troubleshooting an engine is to check the simple things first.
- T 13. Micrometer calipers are identified by the maximum size they can measure.
- F 14. If it is necessary to replace a flywheel key use an extra hard metal key so it won't break easily.
- F 15. Valve springs are used to open the valves.

- T 16. A telescoping gauge can be used to measure cylinder diameter.
- T 17. If an engine floods, the trouble could be caused by a plugged air cleaner.
- T 18. A torque wrench is used to measure the lbs. of force applied when tightening a bolt or nut.
- F 19. The carburetor is a device for mixing fuel and lubricating oil.
- F 20. If it is at all possible, remove the micrometer while it is in contact with the work being measured.

### FILL IN THE BLANKS.

- The four events of a four-stroke engine (in order) are: intake, compression, power, and exhaust.
- It takes two revolutions of the crankshaft to complete one cycle in a four-stroke engine.
- In a four-stroke engine the crankcase contains lubricating oil.
- The valves are held closed by the springs.
- A seal is made between the piston and cylinder wall by oil rings.  
The valves are opened by camshaft.
- The connecting rod connects the piston and crankshaft.
- The three common types of ring are compression, scraper, and oil.
- Both valves are closed on the compression and power stroke.
- A condenser temporarily collects and stores surges of electricity.
- Change the following to the decimal equivalence of:  $7/8 =$  .875,  $32/64 =$  .50,  $3/8 =$  .375.
- Write the following numbers.  
Eight hundred thirty-one thousandth .831  
Two hundred eighty-eight thousandth .288
- When using Plastigage, the more the material is flattened, the smaller the measurement.
- Convert the following pound inches to pound feet:  
144 pound inches = 12 pound feet ;  
48 pound inches = 4 pound feet .

15. Two important clearances for piston rings are end and groove.
16. The magneto ignition system is made up of two circuits; the primary and secondary.
17. A tachometer is used to measure engine RPM.
18. The end of the primary coil winding is connected to breaker points and the end of the secondary winding is connected to the spark plug.
19. The choke provides a rich fuel mixture by restricting the air supply to help start cold engines.
20. The spark plug fires when the breaker points open.

### MATCHING

	<u>COLUMN A</u>	<u>COLUMN B</u>
<u>F</u>	1. Movement of piston, $\frac{1}{2}$ revolution, distinct complete event.	A. Camshaft
<u>L</u>	2. Travels slower as it nears TDC and BDC.	B. Intake stroke
<u>H</u>	3. Spark that occurs at end of exhaust stroke.	C. Horsepower
<u>B</u>	4. Piston moves down, intake valve open.	D. Exhaust stroke
<u>P</u>	5. Always equal to $\frac{1}{2}$ stroke.	E. Connecting rod
<u>I</u>	6. Piston moves down, both valves closed.	F. Stroke
<u>E</u>	7. Transfers power from piston to crankshaft.	G. Combustion chamber
<u>K</u>	8. Turns 720 degrees in one cycle.	H. Maverick spark
<u>O</u>	9. Piston moves up, both valves closed.	I. Power spark
<u>A</u>	10. Turns $\frac{1}{2}$ speed of crankshaft.	J. 720 degrees
<u>N</u>	11. $\frac{(\text{bore})^2}{4} \times 3.14 \times \text{stroke}$ .	K. Crankshaft
		L. Piston
		M. Micrometer
		N. Piston displacement
		O. Compression
		P. Crankshaft
		Q. Bore
		R. Cycle

- Q 12. Diameter of cylinder.
- M 13. Used by mechanics to make measurements to .000 inch.
- C 14. Where fuel is burned and power generated.
- C 15. Power rating of an engine.

IDENTIFY THE FOLLOWING:

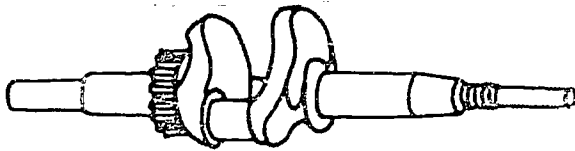

1. crankshaft

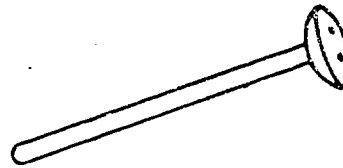

2. valve

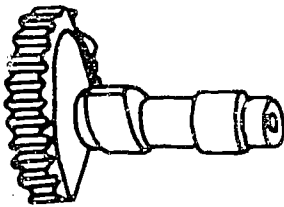

3. camshaft

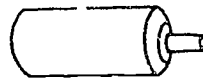

4. condenser

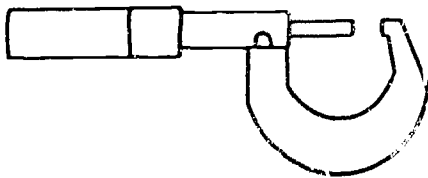

5. micrometer

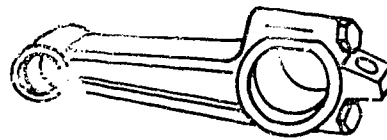

6. connecting rod

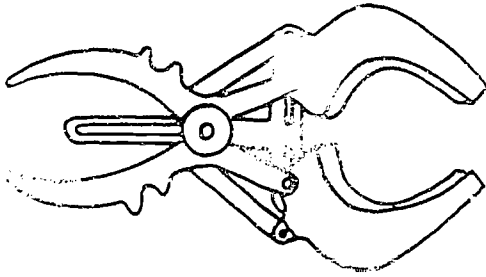

7. ring expander



8. flywheel holder

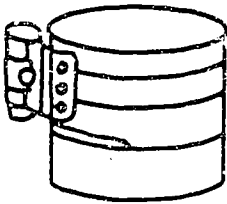

9. ring compressor

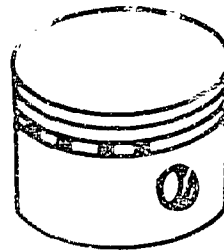

10. piston



0" - 1" micrometer

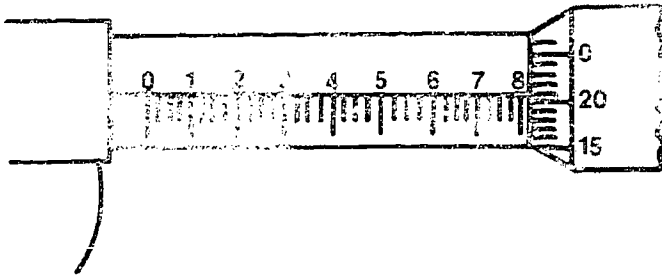

11. 0.821

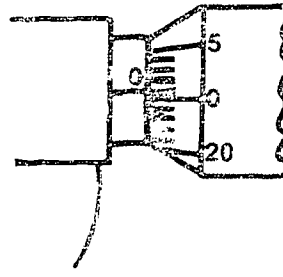

12. 0.001

2" - 3" micrometer

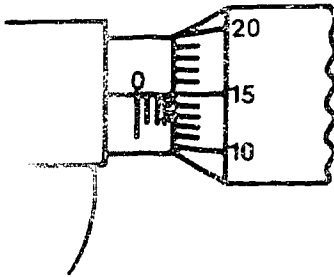

13. 2.090

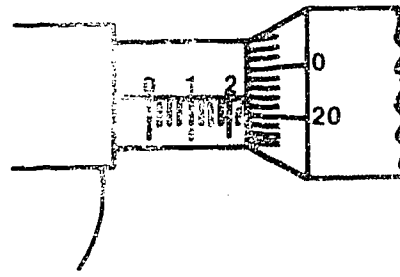

14. 2.247

5" - 6" micrometer

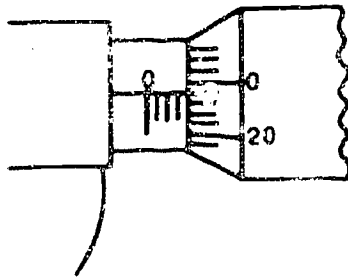

15. 5.099

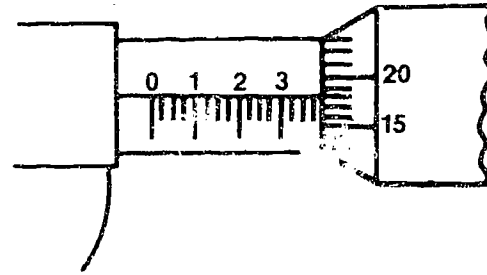

16. 5.393

## UNIT H: AGRICULTURAL MECHANICS

### PROBLEM AREA: ADJUSTING AND MAINTAINING COMBINE HARVESTING EQUIPMENT

#### SUGGESTIONS TO THE TEACHER:

This problem area is designed for use with eleventh grade or advanced students in vocational agriculture programs. The recommended time for teaching this problem area is during the fall semester, before harvesting begins.

The estimated instructional time for this problem area is 5 to 7 days, depending on how far the teacher wishes to go in development of combine adjusting skills. If the students are to be involved in other activity exercises, the instructional time will need to be increased.

Instructors are encouraged to conduct a local search to locate other supplementary materials for use with this problem area. The items in this problem area are for reference or modification as instructors adapt these materials to their local situation.

#### CREDIT SOURCES:

These materials were developed through a funding agreement, R-33-13-D-0362-466, with the Illinois State Board of Education, Department of Adult, Vocational and Technical Education, Research and Development Section, 100 North First Street, Springfield, Illinois 62777. Opinions expressed in these materials do not reflect, nor should they be construed as, policy or opinion of the State Board of Education or its staff.

The teacher's guide, student worksheet, transparency discussion guide, and test questions were developed by Al Zwilling, Department of Vocational and Technical Education, University of Illinois. Transparency masters were prepared by the Vocational Agriculture Service, University of Illinois. Suggestions and guidance in the development of these materials were provided by the Rural Core Curriculum Field Test Teachers, and reviewed by the following vocational agriculture teachers:

Don Bergfield - Paris High School  
Eldon Chapman - Herscher High School

## TEACHER'S GUIDE

- I. Unit: Agricultural mechanics
- II. Problem area: Adjusting and maintaining combine harvesting equipment
- III. Objectives: At the close of this problem area, the student will be able to:
  1. Lubricate and adjust a combine following the recommendations listed in the owner's manual.
  2. Prepare combine for winter storage following the procedures outlined in the owner's manual.
  3. Make the following adjustments:
    - a. Reel speed
    - b. Concave adjustment
    - c. Cylinder speed
    - d. Sieve adjustment
    - e. Air flow
    - f. Forward speed
  4. Properly service and maintain the combine during harvest.
- IV. Suggested interest approaches:
  1. Display two toy combines, one in good condition the other one in poor condition, and discuss the importance of proper maintenance.
  2. Ask the following questions to stimulate interest:
    - a. "How do you prepare your combine for winter storage?"
    - b. "How can you decrease field losses by correct adjustments?"
    - c. "How many of you have adjusted a combine or helped someone adjust one?"
  3. Distribute copies of the Competency Inventory to students. Discuss student ratings of competencies to establish the reasons why we need to study this problem area.
  4. Take a field trip to check harvesting losses in soybeans and corn.
- V. Anticipated problems and concerns:
  1. What are the functions of the combine?

2. What are the parts we need to know to adjust the combine?
3. What adjustments do I need to make for the combine to run efficiently?
4. What care should be given to belts?
5. How should I care for the chains?
6. What parts need lubrication and how often should they be lubricated?
7. How do we set the cylinder speed?
8. How do we set concave clearance?
9. How fast should the fan be running?
10. How should the header be adjusted?
11. How should the reel be adjusted?
12. How do the adjustments differ for various crops?

VI. Suggested learning activities and experiences?

1. Conduct an interest approach using one or more of the suggestions in Section IV.
2. Have students identify problems and concerns, and then record.
3. Distribute resource materials and have students find answers to problems and concerns, and discuss.
4. Have students complete Worksheet #1 using VAS 3049 during supervised study.
5. Have students complete Worksheet #2 by dividing the class into small groups, and using an owner's manual. Each group does a particular section, and makes a presentation to the class. After all presentations, the students should have completed their worksheets with the information from other groups.
6. Organize a field trip to an implement dealer, so that the students may become familiar with a combine. Have the students identify parts. Have students check to see how they would make adjustments on the various makes and models present, using Worksheet #3.
7. Organize a field trip to a farm, where students could see the adjustments taking place and the effect upon the reduction of field losses.

8. Show transparencies and discuss the adjustments and maintenance procedures.
9. Have students set up a maintenance chart for their equipment at home. Have students make a drawing and make a presentation to the class on why they chose only certain activities for their maintenance chart.

VII. Application procedures:

1. Students should be encouraged to adjust harvesting equipment on home farm.
2. Students should develop a skill in maintenance, which they can take back to their home farms.
3. Students will be able to add these skills to their supplemental farm jobs in their S.O.E. books.

VIII. Evaluation:

1. Administer a test using some or all of the sample questions included in this problem area.
2. Evaluate students' worksheets.
3. Evaluate questionnaire from field trip.
4. Evaluate home farm maintenance chart.
5. Use Competency Sheet as a form of evaluation by having students evaluate themselves before and after the problem area.

IX. References and aids:

The following materials are available from Vocational Agriculture Service, University of Illinois:

VAS Unit 3048	"Combines: Selecting and Servicing"
VAS Unit 3049	"Combines: Reducing Harvesting Losses"

Supplementary References:

Deere and Company, 1981, Fundamentals of Machine Operation, Combine Harvesting, Second Edition.

Combine Operator's Manual

## COMPETENCY INVENTORY

### ADJUSTING AND MAINTAINING COMBINE HARVESTING EQUIPMENT

1. Student has no knowledge of competency.
2. Student has read about competency.
3. Student has seen competency performed.
4. Student has performed competency.
5. Student has performed competency without supervision.
6. Student does possess skill.
7. Student does not possess skill.

Competency	Circle One				
1. Lubricate per owner's manual	1	2	3	4	5
2. Adjust reel speed	1	2	3	4	5
3. Adjust concave	1	2	3	4	5
4. Adjust cylinder speed	1	2	3	4	5
5. Adjust sieve	1	2	3	4	5
6. Adjust air flow	1	2	3	4	5
7. Adjust forward speed	1	2	3	4	5
8. Check oil	1	2	3	4	5
9. Check tires	1	2	3	4	5
10. Clean air filter	1	2	3	4	5
11. Check bearings	1	2	3	4	5
12. Check sediment bowl	1	2	3	4	5
13. Check battery	1	2	3	4	5
14. Check distributor	1	2	3	4	5
15. Check belts	1	2	3	4	5
16. Check chains	1	2	3	4	5
17. Check hydraulic levels	1	2	3	4	5
18. Check for broken sections	1	2	3	4	5
19. Develop maintenance chart	1	2	3	4	5
20.					
21.					
22.					
23. Identify steps for winter storage				6	7
24. Identify good maintenance practices				6	7
25. Trouble shoot common problems				6	7

These are competencies outlined in the National Ag Occupations Competency Study, for entry level positions in agricultural production.

Name \_\_\_\_\_

Date \_\_\_\_\_

## STUDENT WORKSHEET #1

### TROUBLESHOOTING

(Refer to VAS Unit 3049)

Fill in the blank in each column.

PROBLEM	CAUSE	REMEDY
Crop falling in front of cutter bar after it is cut	Reel speed too slow	
Ear shelling at stalk rolls		Adjust deck plates.
Excessive damage to shelled corn-cracked corn.		Increase cylinder / rotor-to-concave spacing.
Excessive damage to shelled corn-cracked corn		
Cobs and foreign material in grain tank	Insufficient air blast from cleaning fan	
Uneven or bunched feeding of crop to cylinder		Adjust outer ends of auger to proper clearance of bottom. See operator's manual.
Excessive drop in cylinder/rotor speed	a. b.	a. b.
Slugging or overloading of cylinder/rotor	a. b. Too much material entering cylinder/rotor	a. Open concave -to-cylinder/rotor. b.

III-H-5-8

PROBLEM	CAUSE	REMEDY
Grain not threshed from heads	a. b.	a. b.
Grain loss over straw walkers	Straw walkers overloaded, so grain cannot get through material to conveyor augers	
Excessive trash in tailings	Overthreshing	
Reel wrapping in tangled and weedy crops		Install pickup reel

280



## STUDENT WORKSHEET #2

### COMBINE RECOMMENDATIONS AND ADJUSTMENTS

(Refer to owner's manual for specific recommendations.)

Make and model of combine \_\_\_\_\_

Crop to be harvested \_\_\_\_\_

(Not all of the adjustments are on each make of combine.)

ADJUSTMENTS	RECOMMENDATIONS	HOW TO MAKE ADJUSTMENTS
Cylinder Speed		
Concave cylinder clearance		
Rotor speed		
Concave rotor clearance		
Height of cut		
Reel speed		
Reel height		
Position forward or rearward		
Angle of bats on bat reel		
Pick up reel, angle of slats and teeth		
Cutterbar clearance of bat or tines		
Auger clearance of bat or tines		

ADJUSTMENTS	RECOMMENDATIONS	HOW TO MAKE ADJUSTMENTS
Speed		
Chaffer opening		
Chaffer height		
Rear chaffer opening		
Shoe sieve height		
Special shoe sieves		
Fan speed		
Fan wind regulator		
Fan wind deflector		
Guard alignment		
Knife clips		
Wearing plates		
Vertical heel clearance		
Knife retainer clearance		
Horizontal clearance		
Sickle register		

ADJUSTMENTS	RECOMMENDATIONS	HOW TO MAKE ADJUSTMENTS
Cutterbar tilt		
Add-on pick-up guards		

STUDENT WORKSHEET #3

Manufacturer's Name \_\_\_\_\_ Model 2 Size \_\_\_\_\_

A. General Information

1. What is the width of the cutter bar?
2. What is the capacity of the grain tank?
3. What type transmission does the combine have?
4. What are the overall dimensions of the combine?
5. What type cylinder does the combine have?
6. What is the ground speed range?

B. Cutting and Feeding

1. What is the range in the cutting height?
2. What is the speed range for the reel? How is the speed changed?
3. How is the reel adjusted for height?
4. Can the reel be adjusted in relation to the cutter bar?
5. Describe the mechanism used to get the grain from the cutter bar to the cylinder.

6. Is there an adjustment on the pitch of the pick-up fingers? If so, how is it adjusted?

7. What safety items are present?

C. Threshing

1. What is the speed range of the cylinder?
2. Where should this speed be checked?
3. How do we change the speed of the cylinder?
4. How can the threshing action of the cylinder be changed?
5. How is the clearance of the concave cylinder changed?
6. What is the purpose of the cylinder stripper bar? How should it be adjusted?
7. How is the front of the concave adjusted in relation to the rear of the concave?
8. What is the correct speed of the beater? Is there a speed range on it?
9. What is the recommended setting for:  
the cylinder speed--  
concave clearance front--  
concave clearance rear--

D. Separation

1. Does this combine have a grain pan or a raddle and chain?
2. How are the straw walkers adjusted for speed?

E. Cleaning

1. How is the speed of the fan changed?
2. How is the direction of the wind changed? What is the recommended setting?
3. How is the amount of air taken in by the fan regulated?
4. What are the adjustments on the chaffer?
5. How should the chaffer be adjusted?
6. Is there an adjustment on the chaffer extension? If so, how is it adjusted?
7. How is the sieve adjusted?
8. Where are the tailings returned?
9. How are the grain elevator and tailing elevator chains adjusted?

F. Lubrication

1. Explain the lubrication for the chains?

2. What care should be given the safety clutches?

3. Point out the areas of lubrication and give the frequency of lubrication.

G. Safety

What are the safety features of this machine?

H. Special Equipment

What special equipment or attachments are available for this machine?

I. Discuss the beginning of the season care.

J. Discuss the end of the season care.

## JOB SHEET 1

### PREPARING ENGINE FOR WINTER STORAGE.

#### OBJECTIVES:

1. To develop the ability to properly prepare a combine engine for winter storage.
2. To develop the ability to service each of the various engine components.

#### MATERIALS:

1. Combine needing to be prepared for winter storage.
2. Tools
3. Refill lubricants.

#### PROCEDURE:

1. Wash the outside of the engine with diesel fuel and a brush.
2. Remove air cleaner, replace filter, and clean.
3. Drain, flush, and refill, the cooling system.
4. Drain the fuel tank, and the sediment bowl.
5. Drain the crank case, while the engine is warm. Replace the oil filter, and fill the crankcase, with the new oil of proper weight and quality.
6. Remove the battery, and store in a cool dry place. Check to make sure battery is fully charged.

#### QUESTIONS:

1. What substance did you use to wash the outside of the engine?  
\_\_\_\_\_
2. What should be added to the cooling system before storing for winter?  
\_\_\_\_\_
3. Why is it best to drain the crankcase while it is warm?  
\_\_\_\_\_
4. Why should the battery be removed from the combine?  
\_\_\_\_\_

OBSERVATIONS: Describe what you saw when you drained the crankcase, fuel system, and cooling system.

APPLICATION: Outline the steps to follow when preparing it for winter storage. How do these steps benefit your S.O.E. program?



JOB SHEET 2  
INSPECTION OF COMBINE

OBJECTIVES:

1. To develop the ability to identify problems with a machine, that need to be corrected?
2. To develop the ability to recognize tolerances acceptable to machine operation.

MATERIALS:

1. Combine.
2. Operator's Manual

PROCEDURE:

1. Check the header.
2. Check the chains and belts.
3. Check the separating unit.
4. Check the threshing unit.
5. Check the engine.
6. Check the tires.
7. Check the hydraulic system.

QUESTIONS:

1. What were the problems with any of the seven areas checked?
2. How would you correct these problems.
3. Was the cylinder - concave clearance set at the recommended opening.

OBSERVATIONS:

What technique did you use to decide if belts or chains needed to be replaced? On the sickle and guards?

APPLICATION:

Describe how this skill can be used to benefit your S.O.E. Program.

29

TEACHER'S KEY  
STUDENT WORKSHEET #1  
TROUBLESHOOTING

(Refer to VAS Unit 3049)

Fill in the blank in each column.

PROBLEM	CAUSE	REMEDY
Crop falling in front of cutter bar after it is cut	Reel speed too slow	Adjust reel speed to deliver crop to platform. Reel should turn 25% faster than forward travel of combine.
Ear shelling at stalk rolls	Deck plates not adjusted properly	Adjust deck plates.
Excessive damage to shelled corn-cracked corn	Concave too close to cylinder/rotor bars	Increase cylinder/rotor-to-concave spacing.
Excessive damage to shelled corn-cracked corn	Cylinder/rotor speed too fast	Slow down cylinder/rotor speed. Also check combine beater speed or combine primary counter-shaft speed as shown in combine owner's manual.
Cobs and foreign material in grain tank	Insufficient air blast from cleaning fan	Increase fan speed to obtain sufficient air blast. Lower front of sieve. Keep sieve clear of pieces of cob and obstructions.
Uneven or bunched feeding of crop to cylinder	Auger clearance too high from platform bottom	Adjust outer ends of auger to proper clearance of bottom. See operator's manual.

PROBLEM	CAUSE	REMEDY
Excessive drop in cylinder/rotor speed	<ul style="list-style-type: none"> <li>a. <u>Improper adjustment of primary countershaft drive belts</u></li> <li>b. <u>Basic separator speed not correct</u></li> </ul>	<ul style="list-style-type: none"> <li>a. <u>Tighten primary countershaft drive belts.</u></li> <li>b. <u>Check primary countershaft speed with engine at full throttle, no load.</u></li> </ul>
Slugging or overloading of cylinder/rotor	<ul style="list-style-type: none"> <li>a. <u>Concave-to-cylinder/rotor spacing too close</u></li> <li>b. <u>Too much material entering cylinder/rotor</u></li> </ul>	<ul style="list-style-type: none"> <li>a. <u>Open concave-to-cylinder/rotor.</u></li> <li>b. <u>Reduce ground speed travel.</u></li> </ul>
Grain not threshed from heads	<ul style="list-style-type: none"> <li>a. <u>Cylinder/rotor speed too slow</u></li> <li>b. <u>Cylinder/rotor-to-concave spacing too wide</u></li> </ul>	<ul style="list-style-type: none"> <li>a. <u>Increase cylinder/rotor speed enough to do a good job threshing.</u></li> <li>b. <u>Close cylinder/rotor-to-concave spacing to increase threshing actions.</u></li> </ul>
Grain loss over straw walkers	Straw walkers overloaded, so grain cannot get through material to conveyor augers	<u>Reduce ground travel speed to reduce amount of material entering combine. Raise cutting platform to cut less material (small grains).</u>
Excessive trash in tailings	Overthreshing	<u>Open cylinder/rotor-to-concave spacing and/or reduce cylinder rotor speed.</u>
Reel wrapping in tangled and weedy crops	<u>Slat reel not efficiently delivering crop</u>	Install pickup reel.

# Proper Maintenance

Combine Maintenance Chart

Activity	Date Performed			
Change oil	9/15	9/30		
Grease bearings	9/13	9/14	9/16	
Check belts	9/13			
Check chains	9/12			
Check hydraulics	9/12			
Check battery	9/13			
Clean air filter	9/16	9/30		
Check electrical systems	9/12			
Check header	9/15			
Check guards and sickle	9/15			
Check cylinder rasp bars	9/12			
Check tires	9/12			
Check bearings	9/15	9/16	9/17	
Other				

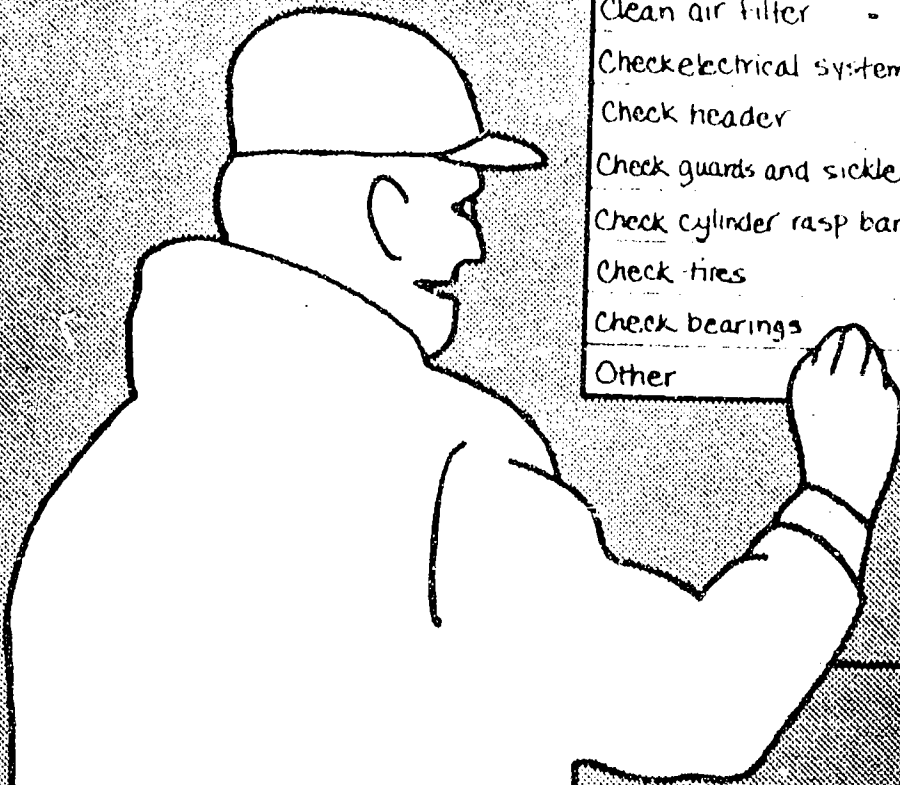

Proper maintenance is a must to insure efficient and safe operation of the combine.

# General Maintenance

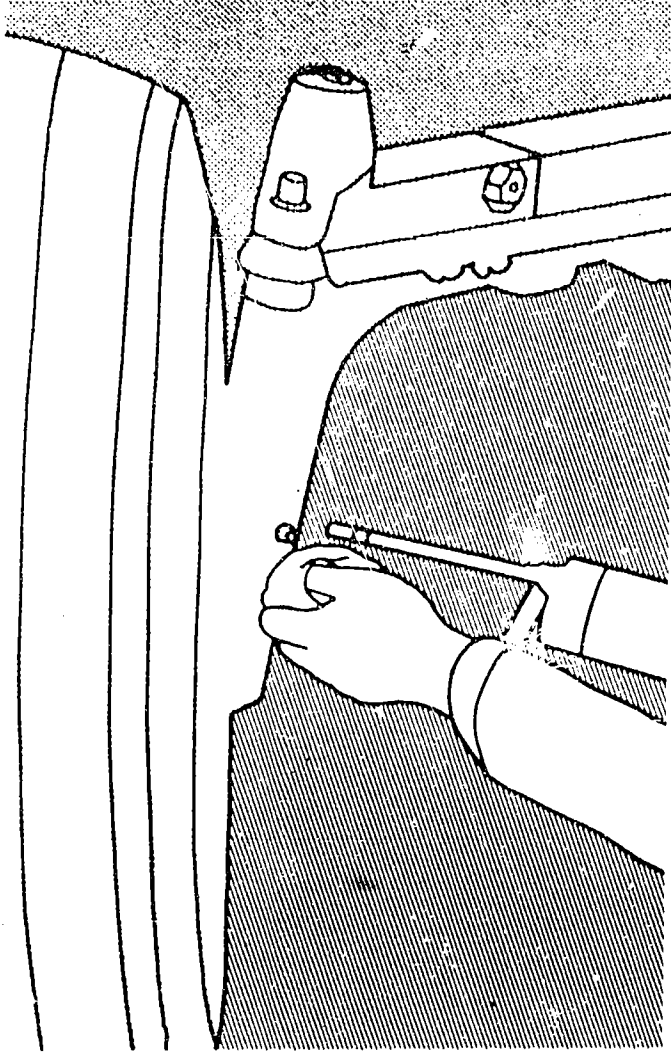

Always wipe the grease fitting before and after greasing.

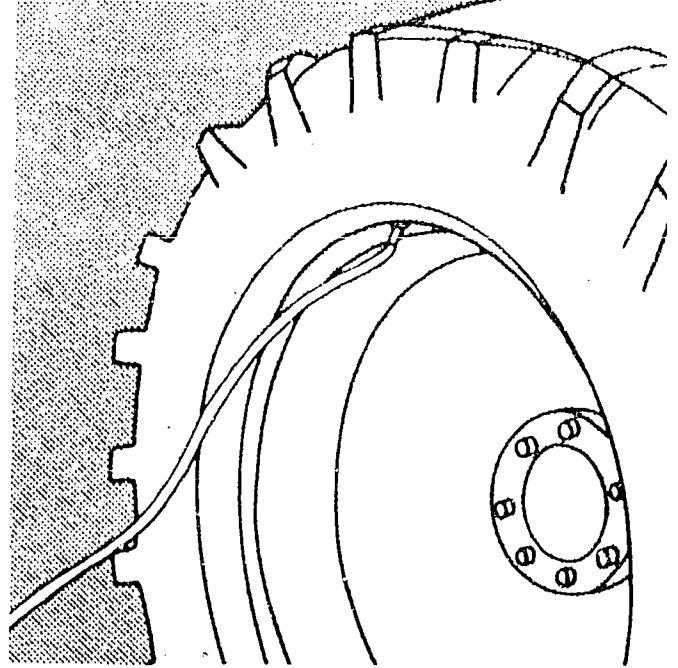

Check the tire pressure.

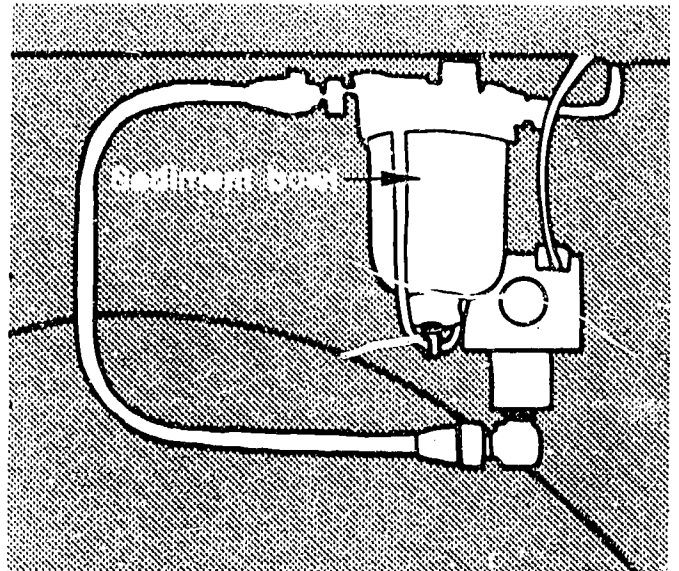

Check for dirt in sediment bowl.

# General Maintenance

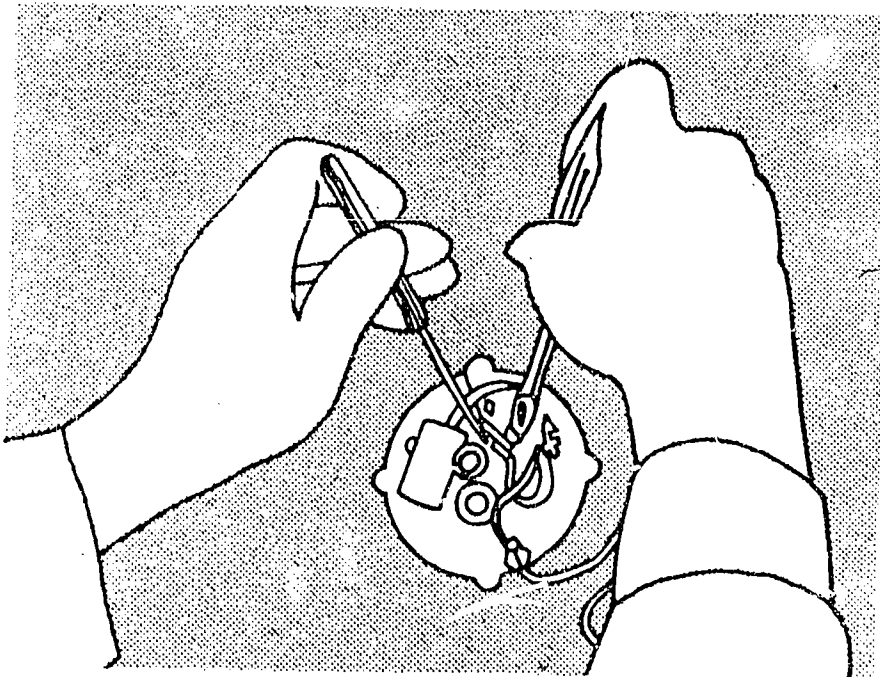

Check distributor breaker point gap.  
(spark-ignition engines.)

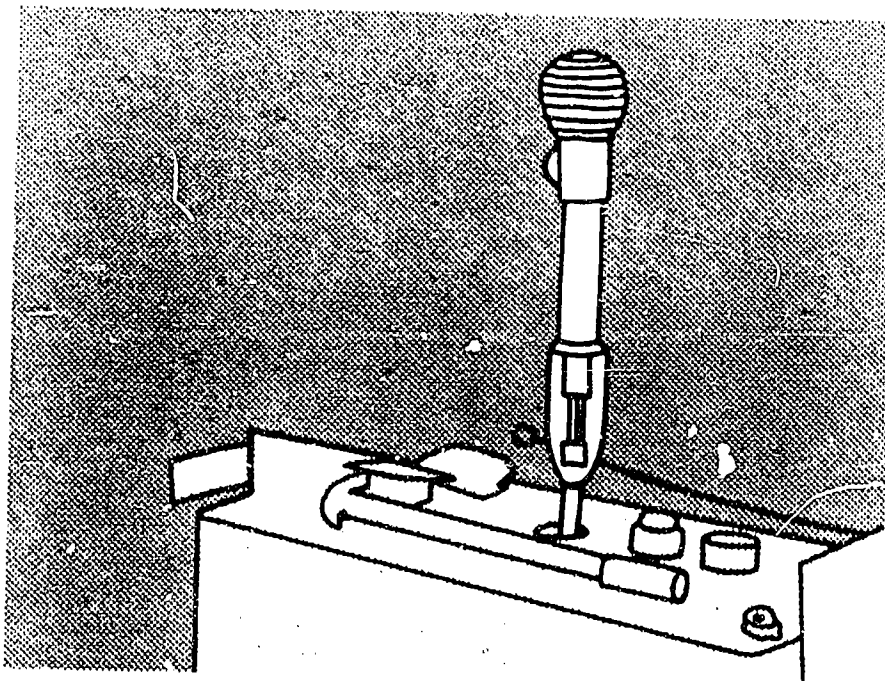

Check the battery.



# Belt and Chain Maintenance

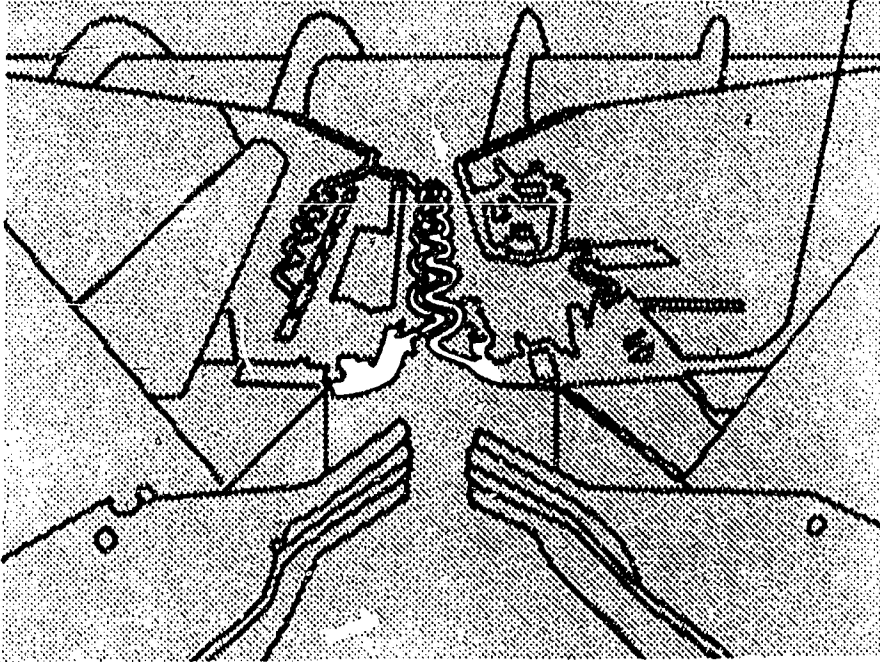

Keep chains adequately tensioned.

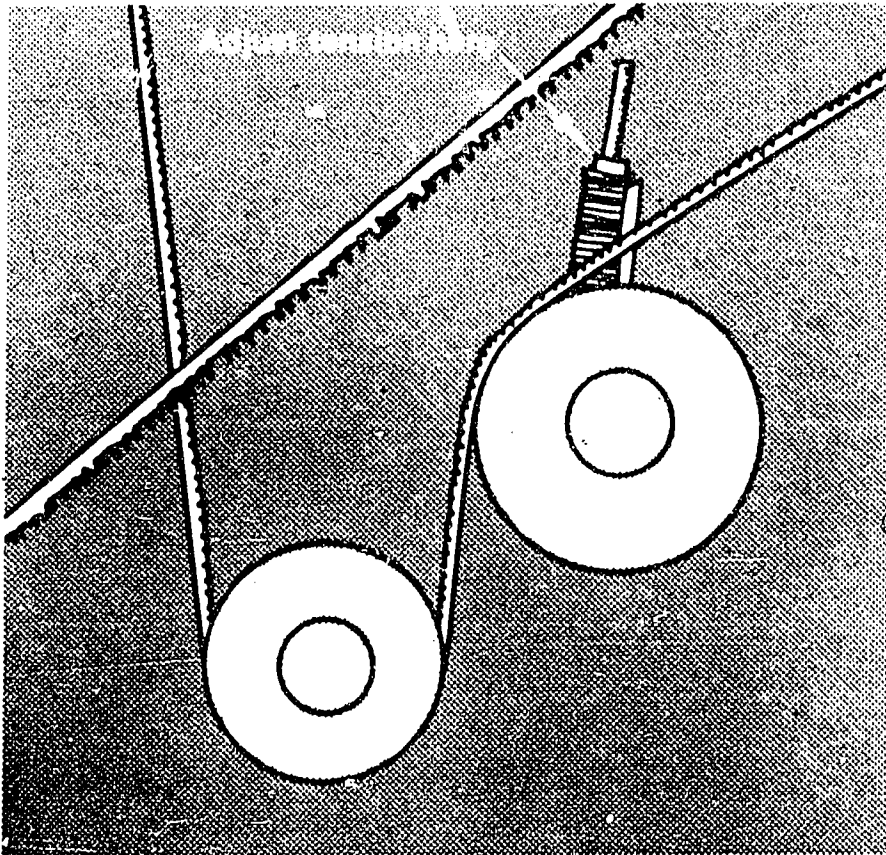

Spring-type belt tension adjuster.

# Belt and Chain Maintenance

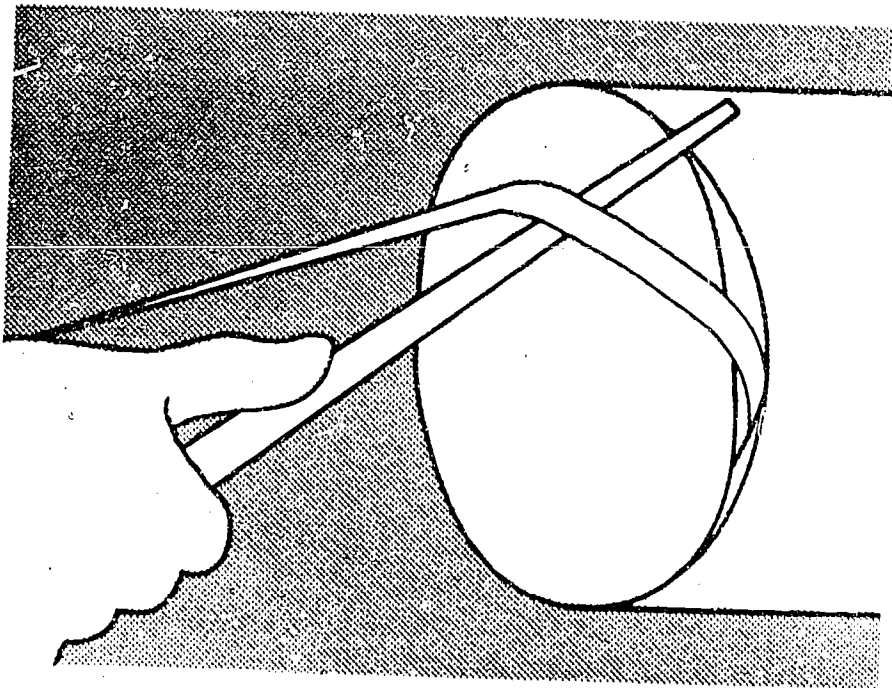

Never pry a belt onto or off a pulley.

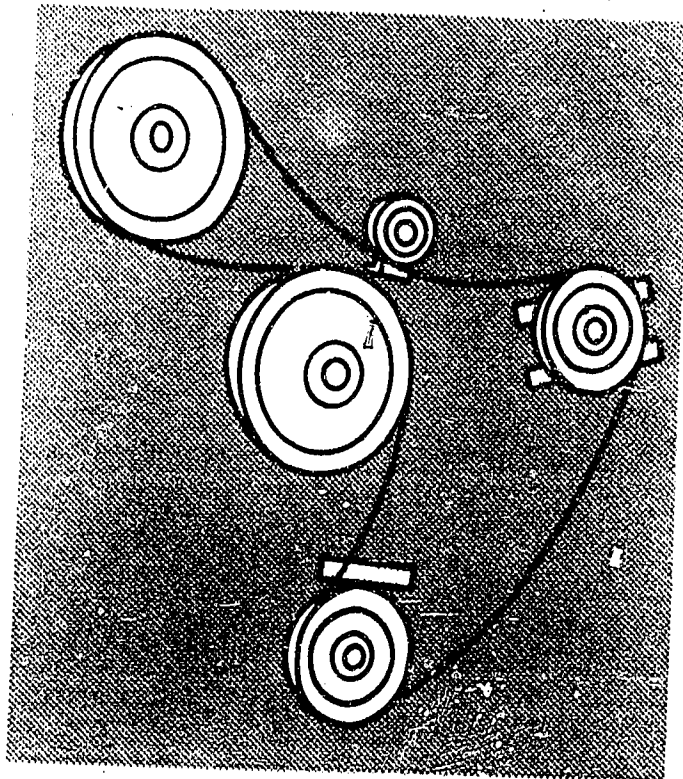

Loosen all belts if stored on the machine in off seasons.



# Operation of Stone Doors

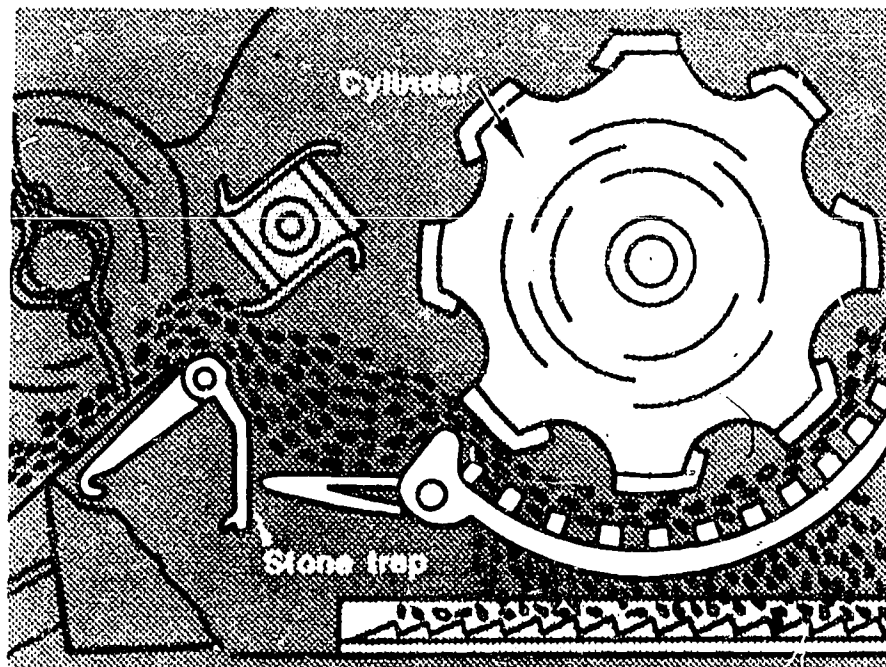

Stone trap must be opened manually.

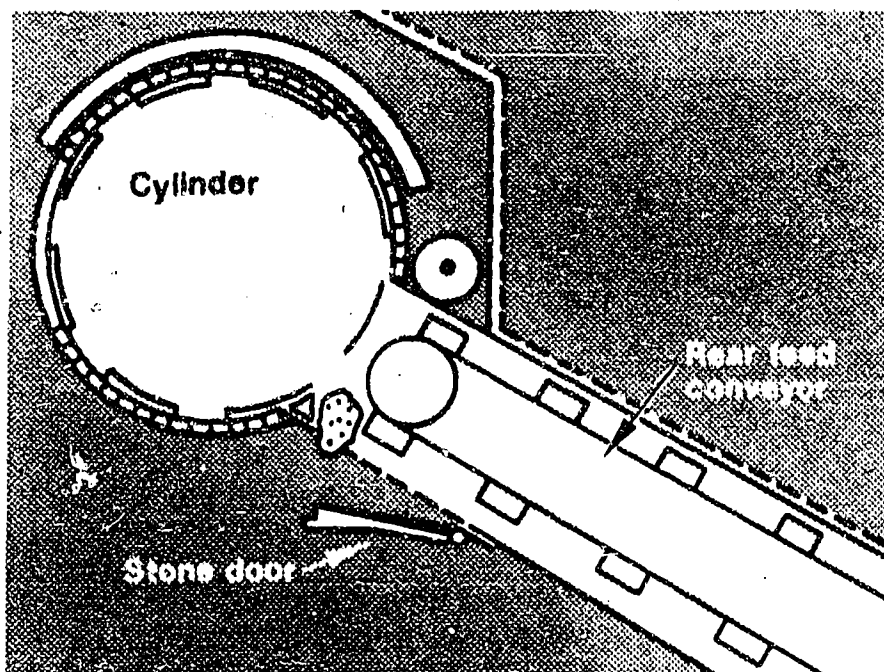

Automatic stone door.

# Reel Adjustments

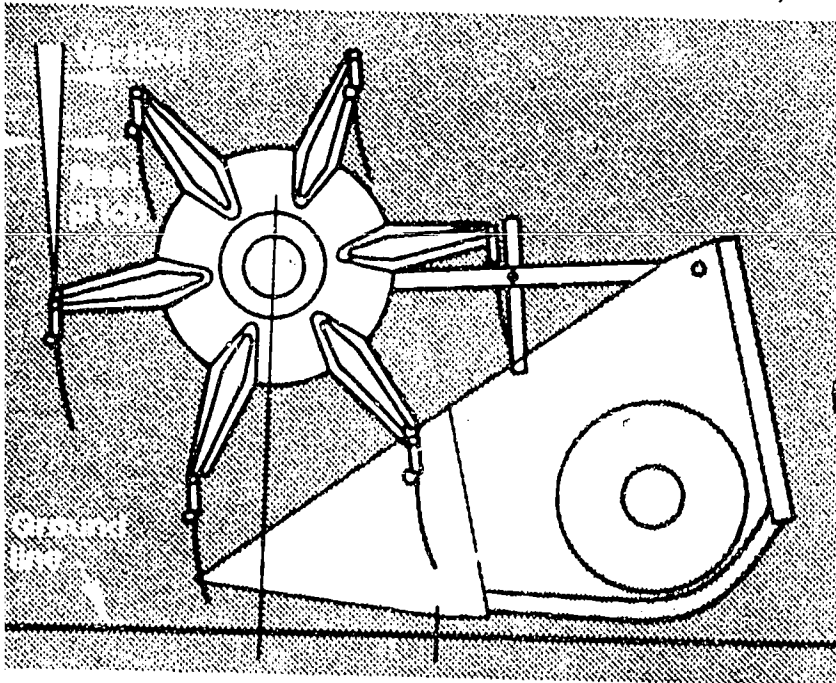

Typical adjustments and clearances for one model pick-up reel.

Make all reel adjustments with header in cutting position.

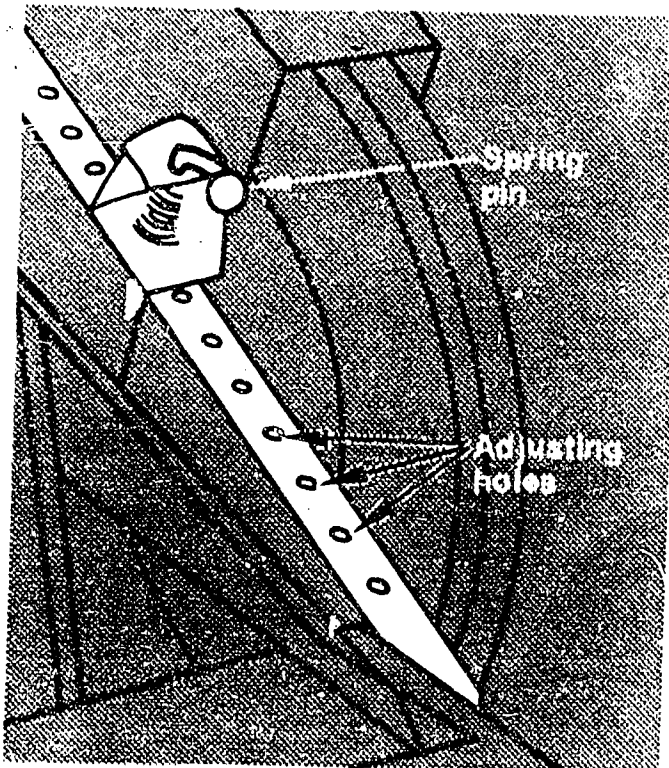

A series of holes is provided on the reel support arms so the reel may be moved forward or backward.

## Reel Height Adjustment

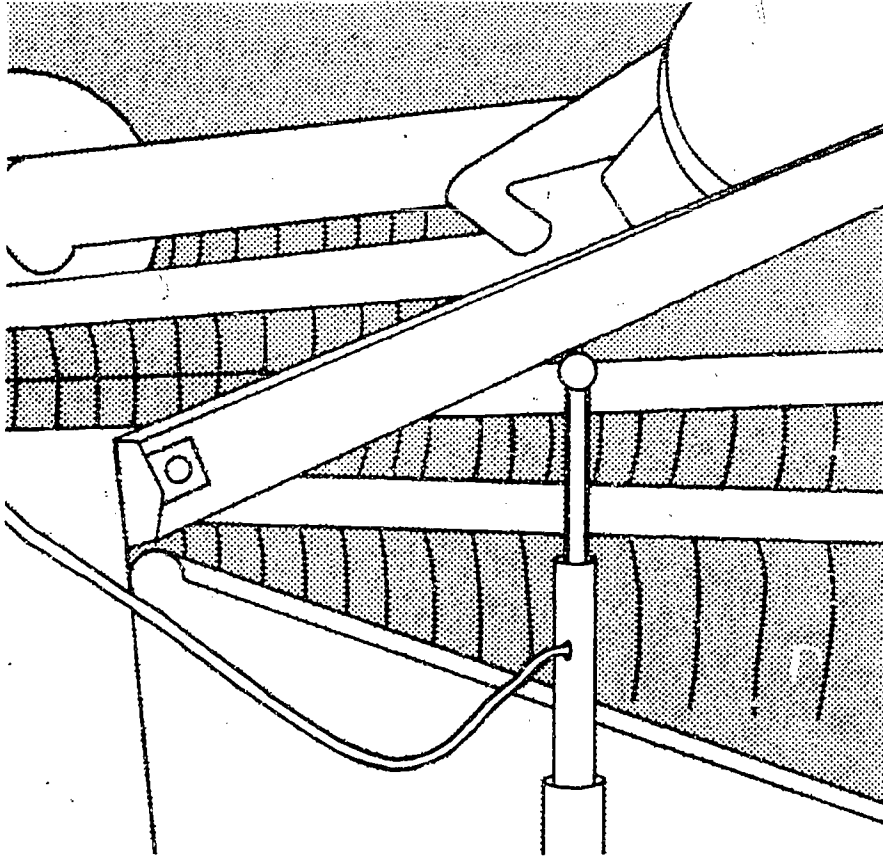

The reel is moved up and down by a hydraulic cylinder.

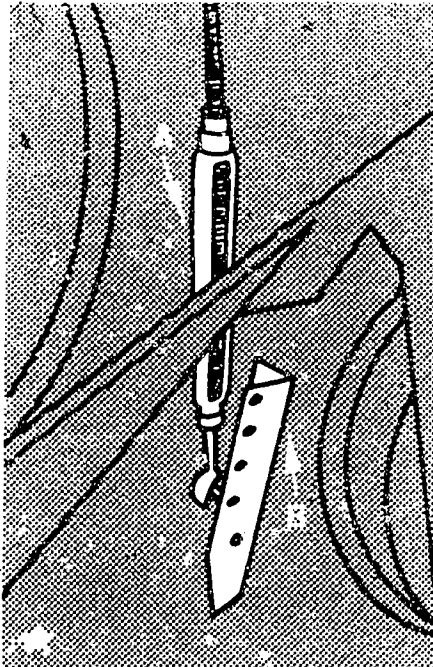

The reel height may be adjusted manually by use of the turn buckle A and by moving the reel up and down on the support bracket B.

305



# Concave-Cylinder Adjustment

Two methods of adjustments

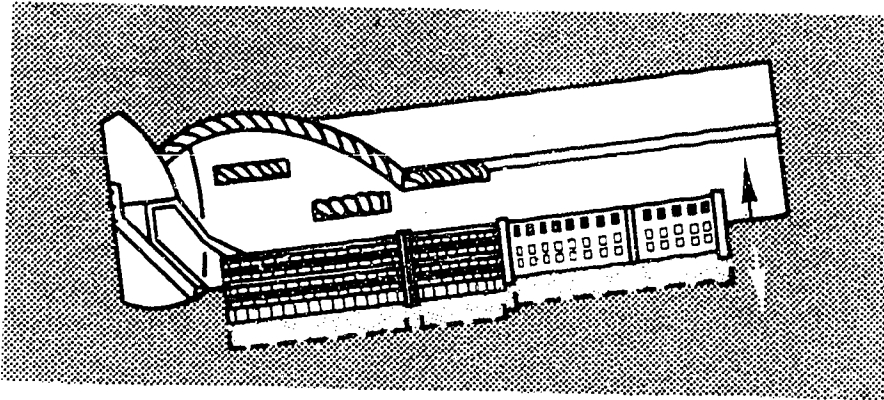

1. Concave type adjustment (Rotary combine)

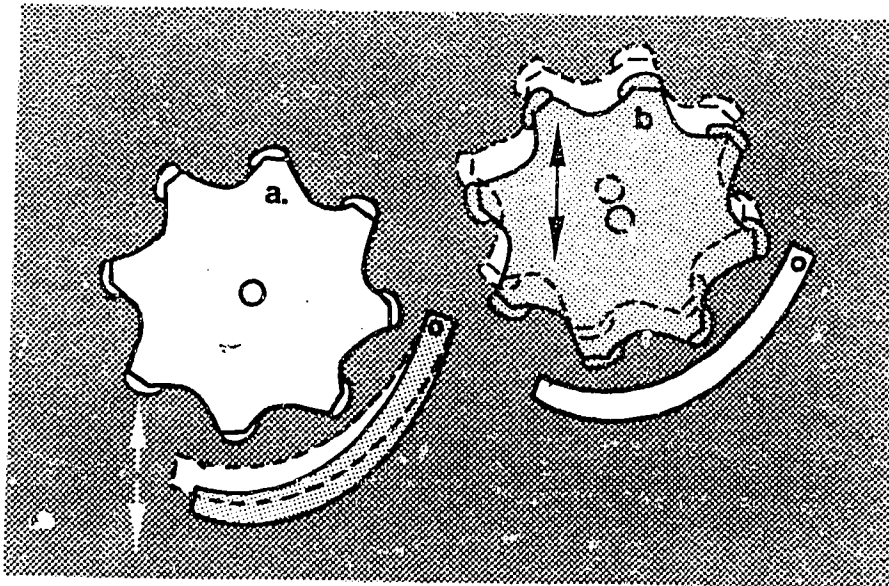

- 2.a. Concave type adjustment  
(Only concave moves up and down)
- b. Cylinder type adjustment  
(Only cylinder moves up and down)

# Fan and Shutter Adjustments

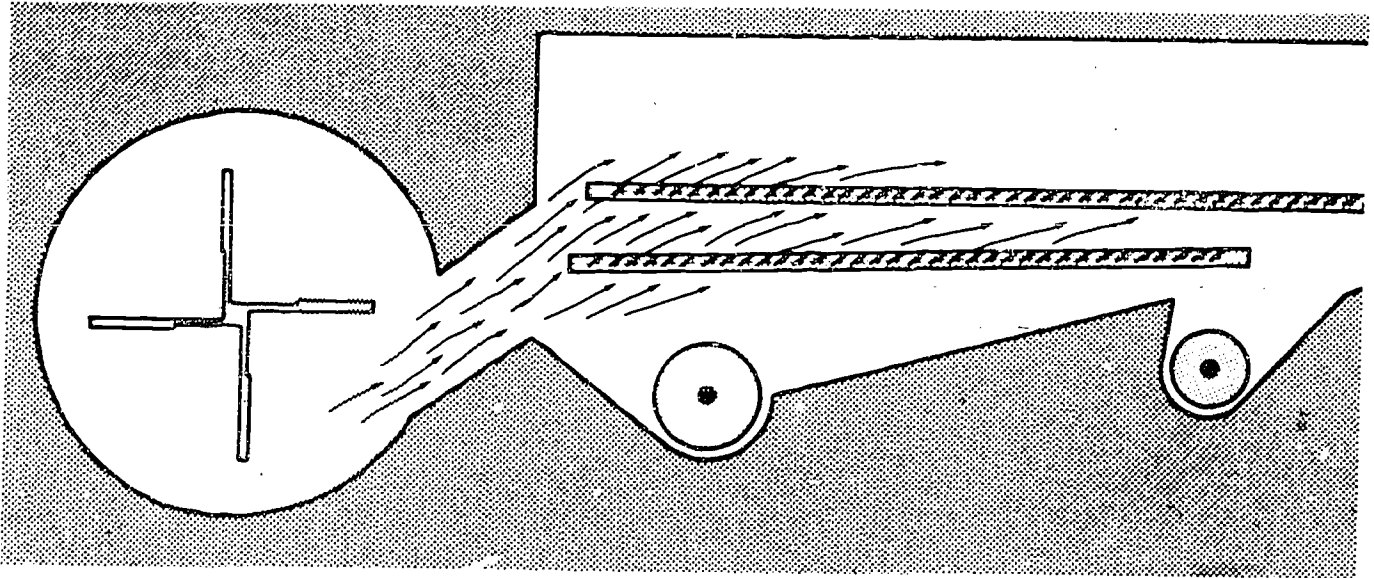

Fan Speed Control

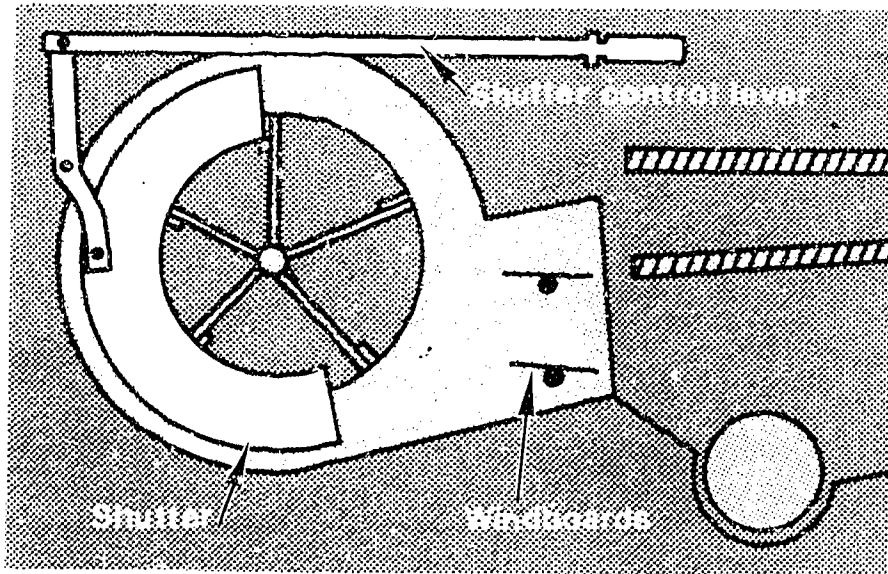

Shutters and Windboards

# Miscellaneous Adjustments

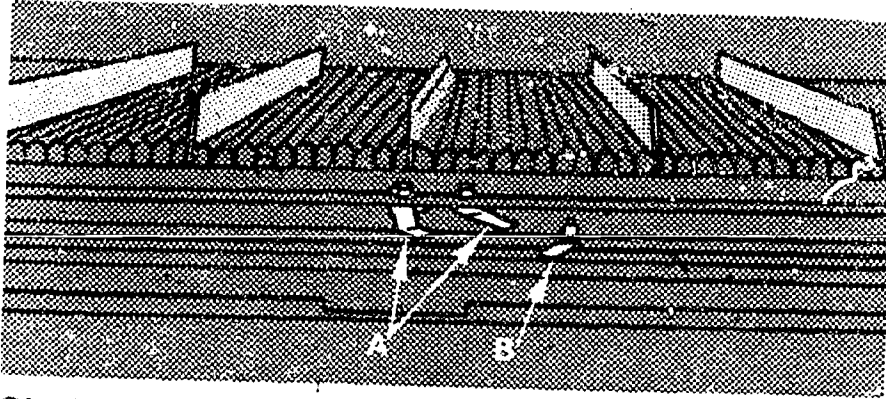

Chaffer and sieve controls

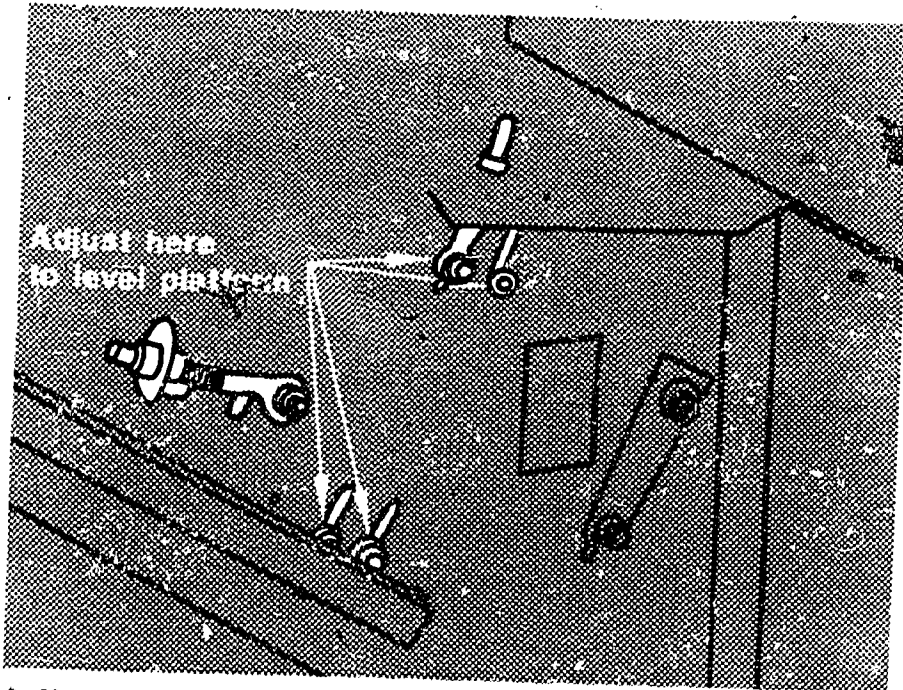

Adjusting bolts for leveling platform



# Miscellaneous Adjustments

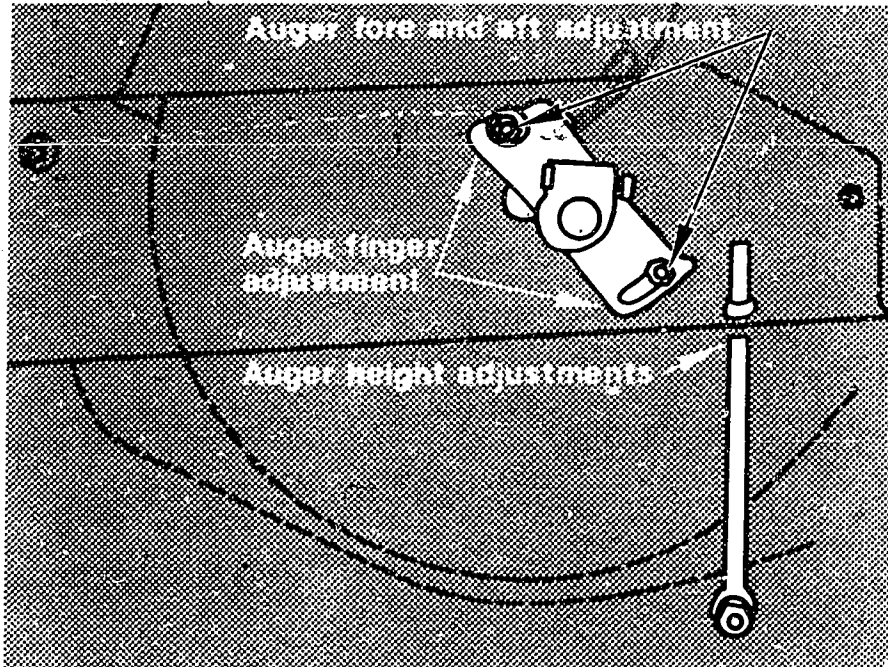

Typical auger adjustments

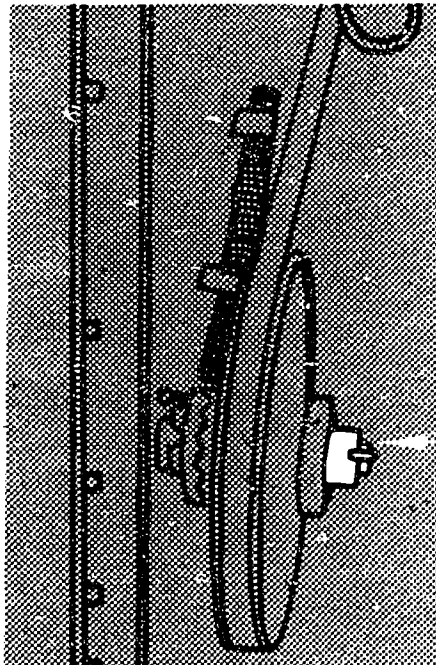

Slip clutch

Adjusting nut

TRANSPARENCY DISCUSSION GUIDE  
ADJUSTING AND MAINTAINING COMBINE HARVESTING EQUIPMENT

- I. Transparency -- PROPER MAINTENANCE
  - A. Discuss the importance of proper maintenance.
  - B. Ask students to identify what maintenance procedures they follow at home, and how they are recorded.
  - C. Emphasize that some activities must be performed daily, while others according to hours used.
  - D. Compile a list of maintenance activities, and how often they should be performed.
- II. Transparency -- GENERAL MAINTENANCE
  - A. Discuss each of the activities shown.
    1. Discuss why it is important to have proper tire inflation.
    2. Discuss the proper cleaning of grease fittings and the amount of grease to apply, and what can happen if too much grease is applied.
    3. Discuss the implications of dirt in the fuel lines, because the sediment bowl was not emptied.
    4. Discuss the distributor breaker point gap.
    5. Discuss how the battery should be tested and maintained.
  - B. Have students list other general maintenance activities and then discuss them.
- III. Transparency -- BELT AND CHAIN MAINTENANCE
  - A. Discuss how belts should be stored when not in use.
  - B. Discuss the do's and don'ts of belts and chains.
  - C. Discuss how most belts and chains are tightened.
- IV. Transparency -- OPERATION OF STONE DOORS
  - A. Discuss why it is important to have stone doors.
  - B. Explain how the manual and automatic stone doors operate.



V. Transparencies -- REEL ADJUSTMENTS

- A. Explain how proper reel adjustments save more crops.
- B. Discuss the different types of reel adjustments, and how each one is made.

VI. Transparency -- CONCAVE-CYLINDER ADJUSTMENTS

- A. Discuss the differences between cylinders and rotors.
- B. Describe how to make the adjustment.
- C. Discuss the recommended settings for various crops.

VII. Transparency -- FAN AND SHUTTER ADJUSTMENTS

- A. Discuss how varying the fan speed changes the cleanliness of the grain.
- B. Describe how to make the adjustment on the fan.
- C. Discuss the effects of changing the shutter.

VIII. Transparency -- MISCELLANEOUS ADJUSTMENTS

- A. Discuss what happens when the chaffer and sieve controls are changed.
- B. Discuss the function of a slip clutch, and how a slip clutch should be adjusted.
- C. Discuss all of the typical auger adjustments.
- D. Discuss why it is important that the platform is level, and how to level it.

TEACHER'S KEY

SAMPLE TEST QUESTIONS

ADJUSTING AND MAINTAINING COMBINE HARVESTING EQUIPMENT

I. True (+) - False (0)

- +   1. Excessive damage to shelled corn is caused by the cylinder/rotor speed being set too fast.
- 0   2. One way to prevent overloading or plugging is to speed up the combine and travel faster.
- 0   3. Increasing the fan speed will usually remedy excessive trash in the tailings.
- +   4. When replacing a belt, never pry it over the rim of a sheave.
- +   5. Use of belt dressings is not recommended, because they may deteriorate the belt.
- +   6. The oil filter and oil lines should be checked for any signs of leakage.
- 0   7. It is usually necessary to lubricate your machine once a week.
- +   8. Cutting is one of the basic harvesting functions.
- 0   9. Storing is one of the basic crop harvesting functions.
- +   10. Clean the combine thoroughly, inside and out.

II. Multiple Choice (Make appropriate choice of A, B, C, D.)

- B   1. The problem of crops falling in front of the cutter bar is caused by
- A. improper lubrication.
  - B. reel speed too slow.
  - C. cylinder speed too slow.
  - D. planting your crops too thin.
- D   2. To reduce cobs and foreign material in the grain tank, one should
- A. decrease cylinder speed.
  - B. increase reel speed.
  - C. shift to a higher gear.
  - D. increase fan speed.

- C 3. To remedy crop not feeding evenly to center of table, one should
- A. adjust auger.
  - B. reduce ground speed.
  - C. all the above
  - D. none of the above
- B 4. Which of the following is not a component of the cleaning unit?
- A. fan
  - B. beater
  - C. chaffer
  - D. sieve
- B 5. The mechanism which cuts or gathers the crop and feeds it to the combine separator is known as
- A. rotor.
  - B. header.
  - C. cylinder.
  - D. auger.
- A 6. To remedy grain loss over straw walkers, one should
- A. reduce ground travel speed.
  - B. install pickup reels.
  - C. open concave.
  - D. increase fan speed.
- C 7. To remedy grain not being threshed from the heads, one should
- A. increase cylinder/rotor speed.
  - B. decrease concave spacing.
  - C. all of the above
  - D. none of the above
- A 8. Combines should be inspected
- A. daily.
  - B. weekly.
  - C. monthly.
  - D. seasonally.

### III. Listing

1. List four practices that a good machine operator should follow.
  - a. Always keep the machine clean.
  - b. Make sure that nuts, cap screws, shields and sheet metal are tight.

- c. Inspect the combine before starting every day.
  - d. Keep maintenance records.
  - e. Don't abuse the machine.
2. List 10 recommended activities before putting combine away for winter storage.
- a.
  - b.
  - c.
  - d.
  - e.
  - f.
  - g.
  - h.
  - i.
  - j.

Essay:

Explain why, when lubricating a bearing, you should only add the recommended number of pumps, instead of watching for the grease to come out of the bearing.

## UNIT H: AGRICULTURAL MECHANICS

### PROBLEM AREA: DEVELOPING CONCRETE AND MASONRY SKILLS

#### SUGGESTIONS TO THE TEACHER:

This problem area is designed for use with junior or senior students in an agricultural mechanics program. The recommended time for teaching this problem area is during the spring when the class could be involved in a concrete project out-of-doors. If such a class project is planned, the teacher should schedule at least 2 or 3 weeks for this problem area.

Most of the materials and instructional activities included in this problem area are based on VAS Unit 3007a "Concrete Improvements for Farm and Home" and VAS Unit 3034 "Recommended Practices for Building with Concrete Masonry" available from Vocational Agriculture Service, University of Illinois. Teachers should order multiple copies of these units prior to instruction. Also, a concrete kit is available from Vocational Agriculture Service on a loan basis to use in conducting laboratory exercises.

#### CREDIT SOURCES:

These materials were developed through a funding agreement R-33-13-D-0362-466 with the Illinois State Board of Education, Department of Adult, Vocational and Technical Education, Research and Development Section, 100 N. First Street, Springfield, Illinois 62777. Opinions expressed in these materials do not reflect, nor should they be construed as policy or opinion of the Illinois State Board of Education or its staff.

The teacher's guide, student worksheets, laboratory exercises, information sheets, problems and part of the test questions were developed by Dave Trent, Vocational Agriculture Teacher, Reddick High School; John Abell, Vocational Agriculture Teacher, Teutopolis High School; and Paul Hemp, Department of Vocational and Technical Education, University of Illinois. The transparencies and the test questions for VAS Unit 3007a were prepared by Vocational Agriculture Service, University of Illinois. This problem area was reviewed by the following vocational agriculture teachers:

Glenn Sims - Windsor High School  
Dave Trent - Reddick High School  
John Abell - Teutopolis High School  
Richard Petrowich - New Athens High School

## TEACHER'S GUIDE

- I. Unit: Agricultural mechanics
- II. Problem area: Developing concrete and masonry skills
- III. Objectives: At the close of the problem area students will:
  1. Be able to mix and place concrete.
  2. Be able to construct concrete forms.
  3. Be able to cure concrete properly.
  4. Be able to identify, use, and care for concrete tools and equipment.
  5. Be able to recognize good concrete.
  6. Be able to recognize concrete failures.
  7. Be able to plan for masonry construction.
  8. Be able to lay concrete blocks properly.
  9. Understand how to calculate concrete problems and estimate materials.
- IV. Suggested interest approaches:
  1. Announce name of problem area and briefly describe it.
  2. Find out how many students have experience mixing concrete and/or laying blocks, and ask those students to describe their experience.
  3. Have students name uses of concrete and concrete masonry around the home and farm.
  4. Lay out a collection of concrete tools. See if students can identify them.
  5. Ask students if they can distinguish between concrete and cement.
  6. Give students a preview of laboratory and shop activities planned for the problem area.
  7. Ask class who has had experience in making and/or using concrete and masonry. Usually, students only have a vague knowledge of what concrete is and how it should properly be made and used. Impress upon them the importance of knowing the proper use of it.

8. Use examples of poor concrete and masonry work around school to show students and have them try to determine what went wrong.

V. Anticipated problems and concerns of students:

1. What is concrete?
2. What is masonry?
3. What are some advantages of using concrete and masonry?
4. What ingredients are used in making concrete?
5. How should we combine the ingredients of concrete?
6. How should we mix concrete?
7. What are the different concrete mixtures and when should each be used?
8. What tools are needed in concrete work?
9. How should forms for concrete be built?
10. How should we place concrete?
11. How should concrete be finished?
12. How can we reinforce concrete?
13. How do we estimate materials and cost of concrete?
14. What is "ready mix" concrete and how do we order it?
15. Is "ready mix" concrete economical?
16. How should footings be built?
17. How do I lay blocks?
18. How do I lay out a building?
19. What causes concrete failures?

VI. Suggested learning activities and experiences:

1. Conduct an interest approach to arouse student interest and develop a need for learning about concrete.

2. Have class develop a list of learning objectives for this problem area. Use the following lead questions:
  - a. "What should we be able to do at the close of this problem area?"
  - b. "Why is it important for us to learn about concrete and concrete masonry?"
3. Lead students in the identification of their problems and concerns.
4. Conduct supervised study so students can read the reference material and locate information needed to solve problems or use Student Worksheets 1-7 to guide students in their supervised study.
5. Use transparencies included with this problem area to present additional information needed to solve problems and concerns.
6. Conduct demonstrations outlined in VAS Unit 3007a.
7. Obtain concrete loan kit from VAS (kit is located in each section) and use it to perform lab exercises described on page 23 of VAS Unit 3007a.
8. Involve class in concrete project and block laying project. (Blocks can be layed on cardboard on shop floor and easily dismantled by mixing sugar in the mortar.)
9. Conduct a field trip to visit a ready mix plant, or to observe concrete being placed or blocks being layed.
10. Have class work out problem exercises or complete Student Worksheets 8 and 9 involving the following:
  - a. Amount of concrete needed for a specific job
  - b. Amount of ingredients needed for a specific job using the various water-to-cement-to-aggregate mixes.
  - c. Figure the cost for a specific job and compare to "ready mix."
11. Have students define the following terms:
 

a. Concrete	g. Curing	m. Three core block
b. Portland cement	h. Reinforcing	n. Corner block
c. Coarse aggregate	i. Cement	o. Jamb block
d. Fine aggregate	j. Striking off	p. Header block
e. Footing	k. Darbying	q. Bullnose block
f. Form	l. Mortar	r. Cubic yard
		s. Ready mixed



12. Use the HOBAR Fiberglass Hog Trough Mold to make hog troughs and/or if available, use the Lynn Concrete Company Hog Trough Mold. These troughs can be used with other classes of animals or for purposes other than feeding.

VII. Application procedures:

1. Involve the class in an actual concrete or block laying project.
2. Encourage students to build concrete improvement projects as a part of their S.O.E. program.

VIII. Evaluation:

1. Construct and administer a test using sample questions included with this problem area.
2. Grade students on laboratory work and projects.

IX. References and aids:

1. VAS Unit 3007a "Concrete Improvements for Farm and Home," available from Vocational Agriculture Service.
2. VAS Unit 3034, "Recommended Practices for Building with Concrete Masonry," available from Vocational Agriculture Service.
3. Phipps, Lloyd J., Mechanics in Agriculture, 3rd edition, Interstate Printers and Publishers, Inc. Danville, Illinois.
4. Cement Masons Guide, available from Portland Cement Association, 5420 Old Orchard Road, Skokie, Illinois 60077. 1980 edition available for \$3.50 per copy.
5. "Making Quality Concrete," Portland Cement Association.
6. "Ready Mix Concrete for the Farm," Portland Cement Association.

COMPETENCY INVENTORY  
DEVELOPING CONCRETE AND MASONRY SKILLS

1. Student has no knowledge of competency.
2. Student has read about competency.
3. Student has seen competency performed.
4. Student has performed competency.
5. Student has performed competency without supervision.
6. Student does possess skill.
7. Student does not possess skill.

Competency	Circle One				
Pour Concrete	1	2	3	4	5
Trowel Concrete	1	2	3	4	5
Protect concrete while curing	1	2	3	4	5
Reinforce concrete	1	2	3	4	5
Mix concrete	1	2	3	4	5
Build and treat forms	1	2	3	4	5
Embed bolts and other fastening devices in concrete	1	2	3	4	5
Edge concrete	1	2	3	4	5
Drill holes in concrete	1	2	3	4	5
Lay concrete blocks	1	2	3	4	5
Lay brick	1	2	3	4	5
Use concrete and masonry tools and equipment					6 7
Calculate cubic yards of concrete needed for selected jobs					6 7

These are competencies outlined in the National Ag Occupations Competency Study, 1978, for entry level positions in agricultural production.

Name \_\_\_\_\_ Date \_\_\_\_\_

INFORMATION SHEET  
ESTIMATING CONCRETE NEEDS

1. Formula for estimating volume of a rectangle:

$$\frac{\text{Length} \times \text{width} \times \text{thickness (all in feet)}}{27} = \text{cubic yards of concrete needed}$$

2. Estimating materials:

A "six gallon mix" means 6 gallons of water/bag of cement.

Proportion of cement to fine aggregate to coarse aggregate 1:2½:3

1 cu. yd. of concrete requires:    6½ bags of cement  
   14 cu. ft. of fine aggregate  
   19 cu. ft. of coarse aggregate  
   37.5 gallons of water

A "seven gallon mix" means 7 gallons of water/bag of cement.

Proportion of cement to fine aggregate to coarse aggregate 1:2-¾:4

1 cu. yd. of concrete requires:    5 bags of cement  
   14 cu. ft. of fine aggregate  
   20 cu. ft. of coarse aggregate  
   35 gallons of water

3. Conversion data:

Cement, pounds per bag - 94 pounds

Bag of cement - 1 cubic foot

Fine aggregate, pounds per cubic foot - 91 pounds

Coarse aggregate, pounds per cubic foot - 100 pounds

Water, pounds per gallon - 8 pounds

Concrete, pounds per cubic yard - 4000 pounds approximately

## INFORMATION SHEET

### CONCRETE TERMS

1. Portland Cement - Portland cement is a manufactured product made from limestone and clay or shale. It is ordinarily sold in paper bags each containing 1 cubic foot of cement.
2. Concrete - Concrete is an artificial stone composed of Portland cement, sand, gravel or broken stone and water which when properly mixed and "set," forms "home-made" stone.
3. Hydration - Hydration is a chemical process that takes place when cement and water are mixed.
4. Coarse Aggregate - Consists of gravel, crushed stone, or similar material larger than  $\frac{1}{4}$ " in particle size.
5. Fine Aggregate - Consists of sand and smaller gravel and crushed stone smaller than  $\frac{1}{4}$ " in particle size.
6. Ready-Mixed Concrete - Ready-mixed concrete is concrete mixed at a central location, blended during transit and delivered ready to pour at the job site.
7. Cubic Yard - A cubic yard of concrete is a volume equivalent to a cube which is 3 feet on each side.
8. Reinforcement - Material such as steel mesh or bars which is added to concrete to give it added tensile strength.
9. Forms - Forms are enclosures used to mold and hold new concrete in shape until it has been set.
10. Footing - A properly constructed, even surface to distribute the weight of a building.
11. Curing - Process of concrete hardening due to hydration.
12. Striking Off - Leveling operation that takes the humps and valleys out of the surface of concrete and gives it a true even surface.
13. Darbying - Process used immediately after striking off to help depress the coarser aggregates and bring the mortar to the surface.
14. Mortar - Mixture of masonry cement, sand, and water used to bond blocks together in masonry construction.

15. Three-Core Block - Concrete block with 3 cores. Three-core blocks are  $7 \frac{5}{8} \times 7 \frac{5}{8} \times 15 \frac{5}{8}$  and weigh 40 to 50 lbs. if they are a heavyweight unit and 25-35 lbs. if they are a lightweight unit.
16. Corner Block - Three-core block that is flat on one end for producing a straight edge or corner.
17. Jamb Block - Block designed with cut out edge for door or window jambs.
18. Header Block - Block designed with cut out edge for door or window header.
19. Bull Nose Block - Block designed with rounded corner for streamlined corner.

## INFORMATION SHEET

### SAMPLE DISCUSSION QUESTIONS

Assume that you have graduated from high school and have been employed with a local concrete company as a field representative. You encounter several problems which your customers expect you to solve. How would you respond to the following situations?

1. As you arrive at the office this morning you find a note on your desk from your secretary. It said that the rains last night had wet the sand pile and the workers were wondering if they should adjust their mixture. You go out and look at the sand, take a handful and squeeze it. It feels wet and forms a ball when squeezed and leaves a little moisture on your hands. They want to mix a water tight batch, and need to know how much water to use per sack of cement.
2. When you get back to your office there is a call from a home owner. She wants to mix a batch of concrete for a sidewalk. She wants to use the pond water in the mix and was wondering if it would be O.K. What advice could you give her?
3. Your first field assignment of the day was to go out to see Mr. and Mrs. H. C. Jones. They had poured a slab of concrete last year for a patio and it was already chipping off. When you arrive you notice a limestone driveway near the house with gravel in it. You inquire and the homeowners said they thought that rock was rock and it was handy to use rock from the driveway. What would you do or say to convince them that it was not the cement that was causing the patio to chip away?
4. On your way back to town your secretary called you on the two-way radio and said that the Smith family had started pouring a reinforcing wall in the landscape and was not going to be able to finish today because they were running out of sand. They want to know how to make the wall water-tight at the joint. What would you tell them?
5. When you get back to your office this afternoon your secretary said that a Mr. Avis called and you were to call him back. When you called he said that he was getting ready to pour a patio and he was wondering if there was any advice you could give him about the forms. What would you tell him?
6. On your way back from Mr. Avis's house you are to go by Allen Beck's residence. When you get there they had just finished pouring sidewalk and steps. They said that they wanted a "rough" finish on the steps and a smooth finish on the sidewalk, but had forgotten how to correctly finish them. They want you to outline the steps for them to follow.
7. Your last stop of the day is at Jim Scotts. He had just finished pouring a concrete floor and was wanting it to be as hard as possible. He thinks that concrete hardens if it dries fast. What advice could you give him on how to obtain the hardest possible concrete.

STUDENT WORKSHEET #1  
VAS UNIT 3007a

1. What are 10 advantages of concrete as a building material?  
A. F.  
B. G.  
C. H.  
D. i.  
E. J.
2. What are 3 disadvantages of using concrete as a building material?  
A.  
B.  
C.
3. What are the three ingredients of concrete?  
A.  
B.  
C.
4. What are the 3 properties of fresh concrete which will greatly influence the quality of hardened concrete?  
A.  
B.  
C.
5. What is Portland Cement?
6. When is water suitable to be used for concrete?
7. What is fine aggregate?
8. What is coarse aggregate?
9. What are two rules of thumb that determines the maximum state of aggregate that can be used?  
A.  
B.
10. What is mixed aggregate?

STUDENT WORKSHEET #2  
VAS UNIT 3007a

1. What is the principal factor that determines the strength, watertightness, and durability of concrete?
2. What is the ratio of cement to fine aggregate to coarse aggregate in a 6 gal. mix?
3. What is the ratio of cement to fine aggregate to coarse aggregate in a 7 gal. mix?
4. When should a 6 gallon mix be used?
5. When should a 7 gallon mix be used?
6. What does a 6 gallon mix mean?
7. How do you determine if sand is damp, wet, or very wet?
  - A. Damp
  - B. Wet
  - C. Very Wet
8. What happens when water is added to sand?
9. What is a "workable mix"?

325



STUDENT WORKSHEET #3  
VAS UNIT 3007a

1. Explain how to mix concrete using a  $\frac{1}{2}$  sack batch mixer.
  
  
  
  
  
  
  
  
  
  
2. What are the requirements for a correctly built form?
  - A.
  - B.
  - C.
  - D.
  - E.
  - F.
  
3. What are 3 types of joints commonly used when pouring floors or slabs?
  - A.
  - B.
  - C.
  
4. What should be done to prevent concrete from sticking to the forms?
  
  
  
  
  
5. Why should you water dirt or gravel bottoms before pouring concrete?
  
  
  
  
  
  
  
  
  
  
6. How should concrete be placed in the forms?
  
  
  
  
  
  
  
  
  
  
7. What happens if fresh concrete is overworked?
  
  
  
  
  
  
  
  
  
  
8. What is a good rule of thumb for placing concrete?

STUDENT WORKSHEET #4  
VAS UNIT 3007a

1. Why should reinforcement be used in concrete?
  - A.
  - B.
2. How far should reinforcing steel be overlapped?
  - A.
  - B.
3. What are some of the steps in finishing?
  - A.
  - B.
  - C.
  - D.
  - E.
  - F.
4. What are five methods of consolidation?
  - A.
  - B.
  - C.
  - D.
  - E.
5. What is a darby
6. What is a bull float?
7. Why should control joints be made?
8. When should floating begin?
9. What are six types of finishes?
  - A.
  - B.
  - C.
  - D.
  - E.
  - F.

STUDENT WORKSHEET #5  
VAS UNIT 3034

1. What are five reasons why concrete masonry is a popular type of building construction?
  - A.
  - B.
  - C.
  - D.
  - E.
2. What does a heavy weight unit weigh?
3. What are 6 common shapes of masonry units?
  - A.
  - B.
  - C.
  - D.
  - E.
  - F.
4. What are the dimensions of a 3 core block?
5. Explain how to lay out a building using the right triangle method.
6. Why is a footing needed for all types of foundation walls?
7. For buildings erected on soils of average load carrying capacity, how wide and how deep should the footing be?
  - A. Width
  - B. Depth
8. How far below ground should a footing be placed?

STUDENT WORKSHEET #6  
VAS UNIT 3034

1. What six factors affect the strength of the bond between mortar and block?  
A. D.  
B. E.  
C. F.
2. What determines whether mortar can be retempered because of water loss through evaporation or whether mortar should be discarded because of stiffening due to hydration?  
A.  
B.
3. What care should be given concrete blocks at the job site?  
A.  
B.  
C.
4. How do you determine whether the concrete block is right-side-up or upside down?
5. What is face shell mortar bedding?
6. What is a story or course pole?
7. What is a mason's line?
8. When should all adjustments to the final position of a block be made?
9. What is a closure block?

STUDENT WORKSHEET #7  
VAS UNIT 3034

1. Why should mortar joints be "tooled"?
  - A.
  - B.
2. When should mortar joints be tooled?
3. How can you remove mortar burrs after tooling?
  - A.
  - B.
4. Explain how to install anchor bolts in a block wall.
5. How should mortar droppings on a block wall be removed?
6. You will be building a concrete block wall 8 feet high and 56 feet long. How many blocks will be needed? (You are using three core blocks.)

## STUDENT WORKSHEET #8

### CONCRETE ESTIMATION

1. You are using a 6-gallon mix. Assume that water weighs 8 lbs./gallon and you are using fine and coarse aggregate. How much does 1 cubic yard of concrete weigh?
2. A patio is 20 feet wide and 30 feet long and 4" thick. How many cubic yards of concrete is needed? (Round your figure to the nearest  $\frac{1}{2}$  cubic yard).
3. If you are planning to use a 6-gallon mix for problem #2, how much cement will be needed? How much fine aggregate, how much coarse aggregate, and how much water will be needed?

335

STUDENT WORKSHEET #9

COMPARISON OF READY MIXED VS MIXING YOUR OWN

1. Obtain prices from local sources.
2. Use a 6-gallon mix (6½ bag mix).
3. Price of ready mix per cubic yard \_\_\_\_\_.
4. Cost of mixing your own concrete:

Price of cement per bag \_\_\_\_\_ x 6.25 = \_\_\_\_\_

Price of fine aggregate

per cubic foot \_\_\_\_\_ x 14 = \_\_\_\_\_

(or price of fine/100#) \_\_\_\_\_ x 12.74 = \_\_\_\_\_

Price of coarse aggregate

per cubic foot \_\_\_\_\_ x 19 = \_\_\_\_\_

(or price of coarse/100#) \_\_\_\_\_ x 19 = \_\_\_\_\_

Total mix-your-own price \_\_\_\_\_

## LABORATORY EXERCISE

### SILT TEST

- I. Materials:
  1. Quart jar with lid.
  2. Sand samples to fill jar 2 inches deep.
  3. Water.
- II. Purposes:
  1. To determine how "dirty" sand samples are.
  2. To decide whether or not a sand sample is suitable for making concrete.
- III. Procedures:
  1. Place 2 inches of sand in a glass fruit jar and fill it with water until it is about three-quarters full.
  2. Shake jar vigorously for a minute or two.
  3. Allow to settle for one hour.
  4. Measure silt layer which will settle out on top of the sand.

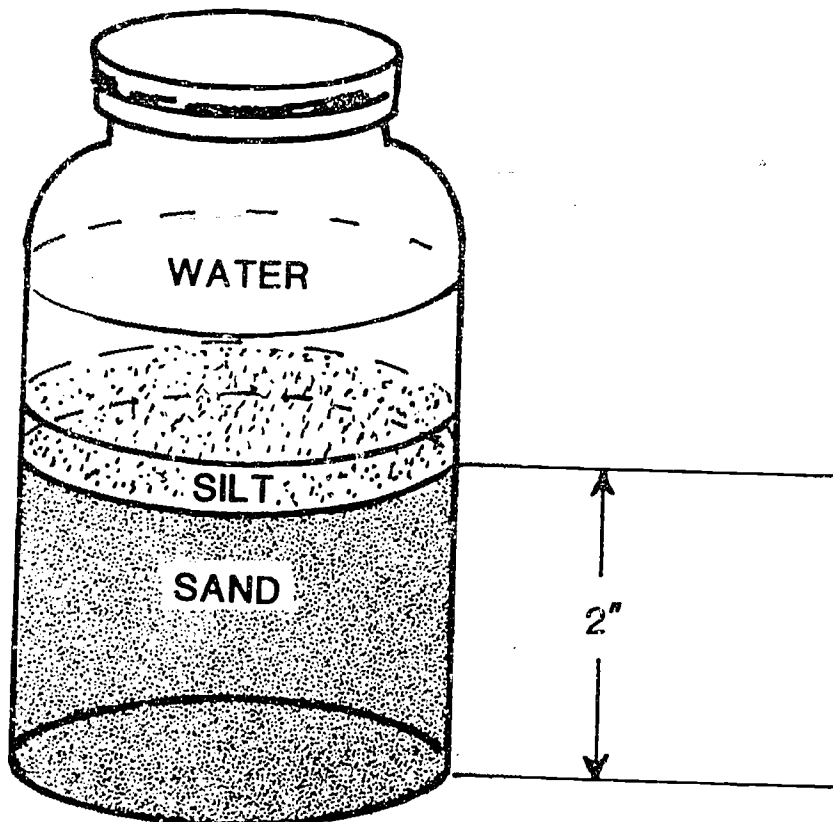



IV. Observations:

1. How thick is the silt layer?
2. Should this sand be used in a concrete mix?  
Note: If layer is more than 1/8 inch thick, sand is too dirty for concrete mixtures.
3. How could the sand be cleaned?

335

LABORATORY EXERCISE  
VAS CONCRETE KIT EXERCISE

(Reference: VAS Unit 3007a)

- I. Objective -- To determine the effect of certain factors on the strength of concrete:
- II. Materials Needed:
  1. Fine and coarse aggregates, portland cement, water.
  2. Mixing pan (about 18 x 24 x 3 inches, or 5 gallon capacity).
  3. Small trowel.
  4. Measuring cup.
  5. Four sets of test beam forms - one of 1-beam, one of 3-beam, and two of 4-beam size.
  6. Two pieces of No. 9 wire, each 12 inches long with 1 inch at each end bent at a right angle.
  7. Set of screens,  $\frac{1}{2}$ -inch mesh and  $\frac{1}{4}$ -inch mesh (may be homemade from hardware cloth).
  8. Breaking machine complete with scale.
- III. Form Arrangement -- Draw a sketch of the forms showing the type mix to be poured in each form.
- IV. Procedure -- Follow VAS 3007a, page 23 and 24, for the correct mixing of ingredients for the various mixtures.
  - A. Prepare sloppy mixture and place in: (8 Gallon Mix)
    1. Form 1
    2. Form 9
  - B. Prepare medium stiff mixture and place in: (7 Gallon Mix)
    1. Form 2
    2. Form 10
    3. Form 5
    4. Form 6
    5. Form 7 -- Place reinforcement rod near the top.
    6. Form 8 -- Place reinforcement rod near the bottom.

- C. Prepare stiff mixture and place in: (6 Gallon Mix)
1. Form 3
  2. Form 11
- D. Prepare sloppy mixture and place in: (8 Gallon Mix)
1. Form 4
  2. Form 12
- E. Cover the following forms with paper and keep moist for 1 day:  
1-2-3-4-6-7-8
- F. Place Form 5 in freezer within 1 hour.
- G. First day after making concrete beams:
1. Remove all forms except Number 5.
  2. Mark all forms with crayon.
  3. Mark top of forms 7 and 8.
  4. Place beams from forms 1, 2, 3, 4, 7, and 8 in water for 7 days.
  5. Let beams from forms 8, 10, 11, and 12 air cure for 7 days.
  6. Place beam from form 6 in freezer for 1 day.
  7. Remove form 5 from freezer and let stand for 1 day.
- H. Second day after making concrete beams:
1. Remove beam 6 from freezer and put in water for 7 days.
  2. Remove forms from Number 5 and put in water for 7 days.
- I. Eighth day after making concrete beams:
1. Remove beams 1, 2, 3, 4, 7, and 8 from water.
  2. Let beams dry for 1 day.
- J. Ninth day after making concrete:
1. Remove beam 5 and 6 from water and let dry for 1 day.
  2. Break beams 1, 2, 3, 4, 7, 8, 9, 10, 11, and 12 with concrete breaker and record results in table below.
- K. Tenth day after making concrete:
1. Break beams 5 and 6 with concrete breaker and record results in table below.
  2. Compare results of the strengths of all beams.

BEAM	WATER-CEMENT RATIO	CURING METHOD	STRENGTH
1	8:1	Moist for 7 days	
2	7:1	Moist for 7 days	
3	6:1	Moist for 7 days	
4	8:1	Moist for 7 days	
7	7:1 Reinforced	Moist for 7 days	
8	7:1 Reinforced	Moist for 7 days	
9	8:1	Air for 7 days	
10	7:1	Air for 7 days	
11	6:1	Air for 7 days	
12	8:1	Air for 7 days	
5	7:1	Freezing immediately, Moist for 7 days	
6	7:1	Moist 1 day, freezing 1 day, then moist for 7 days	

LABORATORY EXERCISE  
MAKING CONCRETE HOG TROUGHS\*

WITH A VIBRATING TABLE

1. Use this basic mix: Cement -- 13 lbs.  
Sand -- 42 lbs.  
Water -- 2 qts.
2. Make correction for moisture in sand.
3. Concrete may be mixed in mortar box, 5-gallon or larger mixer. Divide into two batches when using a 5-gallon mixer.
4. Bore one, 1/8-inch hole in bottom center of the mold and three in the rounded edge of the mold which represents the top edge of the trough. These holes permit air to enter and make mold removal easier.
5. Oil mold.
6. Place 3 inches of concrete in mold and vibrate.
7. Place wire ring in the mold, add concrete equal to one-half of the remaining space and vibrate.
8. Place another wire ring in the mold, add concrete equal to one-half of the remaining space and vibrate.
9. Cut a 10-inch diameter circle of 1-inch poultry netting or five or six lengths of wire and place in mold, add concrete level to top of mold and vibrate.
10. Complete filling mold with concrete and trowel surface smooth.
11. Place plywood platform on top of mold. Grasp plywood and edge of mold. Turn mold over.
12. Tap mold gently with rubber hammer and lift mold from trough. Drier mixes are easier to remove than wetter mixes. (Never allow trough to set up in mold.)
13. Trowel surfaces or fill void spaces by brushing on a grout mixture of cement and water.
14. Troughs should be placed in a water tank for curing after 24 hours. Leave submersed in water for 7 days or fill trough with water and cover with wet burlap.

\*Using a HOBAR Fiberglass Hog Trough Mold

WITHOUT A VIBRATING TABLE:

1. With dry sand, increase water content by  $\frac{1}{2}$  pint. Follow previous procedure.
2. Tamp in concrete with a rounded stick similar to a broom handle or tap gently on the floor in place of using vibrator.
3. Leave trough in the mold for 5 to 45 minutes depending on the moisture content. If the sides slump after removal of the mold, the trough should be left in the mold longer or the quantity of water decreased.

LABORATORY EXERCISE  
MAKING CONCRETE HOG TROUGHS\*

1. MIXING: 3-1 OR SEVEN TROUGHS FROM ONE SACK OF CEMENT.

Screen sand through  $\frac{1}{4}$  inch mesh screen.  
Dry mix 3 parts of sand and 1 part of cement thoroughly.  
Wet enough to make a dry mudball when pressed in the hand.  
Use sprinkler can to wet concrete.
2. MAKING: Pull fingers out.  
Fill mold with mixture and tamp thoroughly to bottom of fingers.  
Push fingers in and lock, using lock on top of fingers.  
Refill mold and tamp until the mold is tamped full.  
Wipe off top side of mold.  
Place the ring on top of mold and work back and forth until ring sets flat on outside of rim of mold.  
Turn ring right until bottom of trough is smooth.  
Remove ring, place board or palet on top of mold and fasten with clamps or bolt on each side of mold.  
Turn mold over with board side down.  
Turn catch on each side  $\frac{1}{2}$  turn.  
Turn top slightly and lift perpendicularly.  
Loosen wing nuts and turn clamp ends from under board.  
Lift mold perpendicularly off trough as soon as completed.
3. CURING Trough should remain on board or palet for 24 hours.  
After 24 hours lift trough off board and do not pile one on top of other the first day.  
Put water in within 24 hours.  
Keep water in trough for ten days or longer.  
Allow trough to cure for at least 21 days, 28 days        better.  
Take a paint-like solution of clear cement and water, and brush troughs on inside to seal pores. May be done on outside also.
4. DO NOT BRUSH BEFORE THE CURING PERIOD IS COMPLETED.
5. KEEP CURING TROUGHS FROM FREEZING.

\*Using mold from Lynn Concrete Company.

34

LABORATORY EXERCISE  
CASTING EXPOSED AGGREGATE CONCRETE ROUNDS

Purpose:

To gain practical experience working with concrete.

Materials:

1. Cement mixer or wheel barrow
2. Strikers
3. Square-nose shovel
4. Garden hoe
5. Floats
6. Cement trowels
7. Portland cement
8. Water
9. Torpedo sand
10. Gravel or aggregate
11.  $\frac{1}{2}$ " plywood rounds 1' to 4' in diameter
12. 16 gauge tin cut into  $2\frac{1}{2}$ " wide strips
13. Reinforcing mesh (6" x 6", 6 gauge) or chicken wire or coat hangers
14. Baling wire
15. Roofing nails

Procedures:

1. Cut the 16 gauge tin into  $2\frac{1}{2}$ " strips and the plywood into 1' to 4' diameter rounds.
2. Fasten the tin strips around the plywood rounds with baling wire and roofing nails. The tin strips may need to be shortened for the smaller rounds.
3. Cut portions of the reinforcing mesh to fit inside the forms. Prop the mesh up on stones so it will be in the center of the concrete. Coat hangers may be cut and lashed together to serve the same purpose.
4. Mix the concrete in a cement mixer or a wheel barrow. The recommended mixing ratio is 1 part sand, 2 parts aggregate, 1.5 parts cement and 6-7 gallons of water/SACK of cement. NOTE: The aggregate used for exposed aggregate does not provide optimum strength of the concrete. Therefore, more than the usual 1 part cement is added.
5. Pour the concrete mix into forms, screed (strike off) and float.
6. After the concrete has firmed up (usually between 1 and 4 hours depending on weather conditions) wash off the "butter" on the



concrete to expose the aggregate. Some light brushing may be necessary, but do not scrub the surface. Scrubbing will loosen the aggregate. Timing is critical for exposing aggregate, and some practice rounds should be made before mass production is attempted.

7. Remove the forms and the plywood.
8. Submerge the rounds in water for several days to cure the concrete.
9. Wash the rounds with muriatic acid.
10. To obtain a glossy finish, treat the rounds with hydroseal.

TEACHER'S KEY

STUDENT WORKSHEET #1  
VAS UNIT 3007a

1. What are 10 advantages of concrete as a building material?
  - A. Firesafe
  - B. Strong
  - C. Resists abrasion
  - D. Insect and rodent proof
  - E. Storm resistant
  - F. Permanent
  - G. Watertight
  - H. Sanitary
  - I. Economical
  - J. Moldable
2. What are 3 disadvantages of using concrete as a building material?
  - A. Forms required
  - B. Demanding
  - C. Labor
3. What are the 3 ingredients of concrete?
  - A. Water
  - B. Portland Cement
  - C. Aggregates
4. What are the 3 properties of fresh concrete which will greatly influence the quality of hardened concrete?
  - A. Consistency
  - B. Uniformity
  - C. Workability
5. What is Portland Cement?

Type of cement made by burning lime, silica, iron oxide, and alumina and grinding the clinker so that 90% will pass through a 200 mesh screen.
6. When is water suitable to be used for concrete?

When the water is suitable for drinking, free from dirt, oil, acid, and alkali.
7. What is fine aggregate?

Sand and gravel smaller than  $\frac{1}{4}$ " in particle size.
8. What is coarse aggregate?

Gravel, crushed and similar material larger than  $\frac{1}{4}$ " in particle size.
9. What are 2 rules of thumb that determines the maximum size of aggregate that can be used?
  - A. Largest particle should not be over  $\frac{1}{5}$  to  $\frac{1}{3}$  the thickness of the concrete being placed.
  - B. Largest particle should not be larger than  $\frac{3}{4}$  of the width of the narrowest opening through which concrete mixture is required to pass when being placed.
10. What is mixed aggregate?

Mixed aggregate is a mixture of fine aggregate and coarse aggregate in the proper proportions for use in mixing concrete.

TEACHER'S KEY

STUDENT WORKSHEET #2  
VAS UNIT 3007a

1. What is the principal factor that determines the strength, watertightness, and durability of concrete?

Water-cement ratio

2. What is the ratio of cement to fine aggregate to coarse aggregate in a 6 gal. mix?

1:2:3

3. What is the ratio of cement to fine aggregate to coarse aggregate in a 7 gal. mix?

1:2 3/4:4

4. When should a 6 gallon mix be used?

For watertight floors and foundations

5. When should a 7 gallon mix be used?

For ordinary foundation walls and footings

6. What does a 6 gallon mix mean?

The mix contains 6 gallons of water per bag of cement

7. How do you determine if sand is damp, wet, or very wet?

- A. Damp--Damp sand falls apart when squeezed.
- B. Wet--Wet sand forms a ball when squeezed.
- C. Very Wet--Very wet sand sparkles and wets your hand.

8. What happens when water is added to sand?

Films of water sticks to the sand and fills it up. This causes an increase in volume.

9. What is a "workable mix"?

One that is smooth and plastic and will space and finish well. It should not be so fluid that it runs or so stiff that it crumbles.

TEACHER'S KEY  
STUDENT WORKSHEET #3  
VAS UNIT 3007a

1. Explain how to mix concrete using a  $\frac{1}{2}$  sack batch mixer.

Explanation is on pages 8-9 of VAS unit 3007a.

2. What are the requirements for a correctly built form?

- A. Substantial enough to retain correct shape when filled
- B. Rigid to resist bending
- C. Strong to resist breaking
- D. Tight to prevent paste loss
- E. Easily filled
- F. Easily removed

3. What are three types of joints commonly used when pouring floors or slabs?

- A. Isolation joints
- B. Central joints
- C. Construction joints

4. What should be done to prevent concrete from sticking to the forms?

Oil with a light machine oil.

5. Why should you water dirt or gravel bottoms before pouring concrete?

To prevent water soaking out of the concrete and changing the cement-water ratio.

6. How should concrete be placed in the forms?

Place in level layers, consolidating it just enough to make it settle thoroughly and produce a dense mass.

7. What happens if fresh concrete is overworked?

Too much water and fine aggregate will be brought to the surface and this will lead to scaling and dusting of the surface.

8. What is a good rule of thumb for placing concrete?

A good rule of thumb for placing concrete is, "Good concrete is placed, not poured." Place the concrete where it is needed, do not flow it, push it, or drag it into place.

TEACHER'S KEY

STUDENT WORKSHEET #4  
VAS UNIT 3007a

1. Why should reinforcement be used in concrete?

- A. To allow concrete to withstand tension
- B. To increase tensile strength

2. How far should reinforcing steel be overlapped?

- A. The minimum lap should be 12 inches.
- B. In welded fabric, overlap 1 square plus 2 inches.

3. What are some of the steps in finishing?

- A. Consolidating
- B. Striking off
- C. Darbying
- D. Floating
- E. Jointing
- F. Finishing

4. What are five methods of consolidation?

- A. Strike off board
- B. Vibrator
- C. Tamper
- D. Roller screed
- E. Jitterbug

5. What is a darby?

A darby is a long flat rectangular piece of wood, aluminum, or magnesium with a handle on top.

6. What is a bull float?

A bull float is a large rectangular piece of wood, aluminum, or magnesium 8" x 36-60" long with a handle 4-12 feet long.

7. Why should control joints be made?

To control the location where it will crack.

8. When should floating begin?

After bull floating or darbying and after concrete starts to harden. Do not begin until water sheen has disappeared from the surface.

9. What are six types of finishes?

- A. Broom finish
- B. Belt finish
- C. Hand float finish
- D. Steel trowel finish
- E. Power trowel finish
- F. Exposed aggregate

## TEACHER'S KEY

### STUDENT WORKSHEET #5 VAS UNIT 3034

1. What are five reasons why concrete masonry is a popular type of building construction?

- |               |                   |
|---------------|-------------------|
| A. Adaptable  | D. Fire Resistant |
| B. Economical | E. Attractive     |
| C. Durable    |                   |

2. What does a heavy weight unit weigh?

40-50#

3. What are six common shapes of masonry units?

- |                    |                   |
|--------------------|-------------------|
| A. 3 core block    | D. Jamb block     |
| B. Corner block    | E. Bullnose block |
| C. Partition block | F. Header block   |

4. What are the dimensions of a 3 core block?

7 5/8" x 7 5/8" x 15 5/8"

5. Explain how to lay out a building using the right triangle method.

Explanation on page 2 of Unit 3034

6. Why is a footing needed for all types of foundation walls?

To provide an even surface on which to start the wall.

7. For buildings erected on soils of average load carrying capacity, how wide and how deep (thick) should be footing be?

- A. Width--Two times the thickness of the wall.  
B. Depth--Equal to the thickness of the wall.

8. How far below ground should a footing be placed?

In all areas subject to freezing, the bottom of the footing must be placed below the frost line.

## TEACHER'S KEY

### STUDENT WORKSHEET #6 VAS UNIT 3034

1. What six factors affect the strength of the bond between mortar and block?
  - A. Type and quantity of cementing material
  - B. Workability of mortar
  - C. Surface texture of mortar bedding areas
  - D. Rate of suction of mortar units
  - E. Water retentivity of mortar
  - F. Quality of workmanship
  
2. What determines whether mortar can be retempered because of water loss through evaporation or whether mortar should be discarded because of stiffening due to hydration?
  - A. Mortar should be used within 2½ hours after original mixing when air temperature is 80°F or higher.
  - B. Mortar should be used within 3½ hours after original mixing when air temperature is below 80°F.
  
3. What care should be given concrete blocks at the job site?
  - A. Stockpile off of the ground
  - B. Cover with canvas or polyethylene sheets
  - C. Never wet blocks before or during the process of laying them in the wall.
  
4. How do you determine whether the concrete block is right-side up or upside down?

Blocks should be layed with the thicker end of the face shell up as this provides a larger area on which to place the mortar bedding.
  
5. What is face shell mortar bedding?

Applying mortar only to the horizontal face shell of the block.
  
6. What is a story or course pole?

A board with markings 8" apart to provide an accurate method of finding the top of the masonry unit for each course.
  
7. What is a mason's line?

A line or string stretched from corner to corner to find the top of each unit in a course.
  
8. When should all adjustments to the final position of a block be made?

Make all adjustments while the mortar is soft and plastic. Any adjustments made after the mortar has stiffened will break the mortar bond.
  
9. What is a closure block?

A closure block is the final block layed in a course after working inward from both corners.

3352

TEACHER'S KEY

STUDENT WORKSHEET #7  
VAS UNIT 3034

1. Why should mortar joints be tooled?

- A. It compacts the mortar and forces it tightly against the masonry on each side of the joint.
- B. It produces joints of uniform appearance with sharp clean lines.

2. When should mortar joints be tooled?

When mortar has become thumb print hard after a section of wall has been laid.

3. How can you remove mortar burrs after tooling?

- A. With the edge of the trowel
- B. With burlap bag

4. Explain how to install anchor bolts in a block wall.

Place a piece of metal lath in the second horizontal mortar joint from the top and under the cores to be filled. Lay the next course and fill the cores with mortar in which the anchor bolts will be imbedded. Embed the anchor bolts with the threaded end up so that they will extend 3/4" above the wood plate to be anchored.

5. How should mortar droppings on a block wall be removed?

Don't remove while the mortar is wet or the mortar will smear into the block. Allow the mortar to dry and remove by rubbing with a small piece of block or by brushing with a wire brush.

You will be building a concrete block wall 8-feet high and 56 feet long. How many blocks will be needed? (You are using three core blocks)

Length 56' x 12"/ft. $\approx$ 672"	672"/16"/block $\approx$ 42	blocks/course
Height 8' x 12"/ft. $\approx$ 96"	96"/8"/block $\approx$ 12	courses high

42 x 12 = 504 blocks will be needed for the wall.



TEACHER'S KEY  
STUDENT WORKSHEET #8  
CONCRETE ESTIMATION

1. You are using a 6-gallon mix. Assume that water weighs 8 lbs./gallon and you are using fine and coarse aggregate. How much does 1 cubic yard of concrete weigh?

$$\begin{array}{r}
 6(\text{gallons of water}) \times 8(\text{lbs. per gallon}) = 300 \text{ lbs.} \\
 6\frac{1}{2}(\text{bags of cement}) \times 94(\text{lbs. per bag}) = 597.5 \text{ lbs.} \\
 14(\text{cu. ft. of fine aggregate}) \times 91(\text{lbs. per cu. ft.}) = 1274 \text{ lbs.} \\
 19(\text{cu. ft. of coarse aggregate}) \times 100(\text{lbs. per cu. ft.}) = 1900 \text{ lbs.} \\
 \text{Total} \qquad \qquad \qquad \qquad \qquad \qquad \qquad \qquad \qquad \underline{4071.5 \text{ lbs.}}
 \end{array}$$

2. A patio is 20 feet wide and 30 feet long and 4" thick. How many cubic yards of concrete is needed? (Round your figure to the nearest  $\frac{1}{2}$  cubic yard).

$$\frac{20 \times 30 \times .33}{27} = 7.33 \text{ cu. yd.} \\
 \text{Round to 7.5 cu. yds.}$$

3. If you are planning to use a 6-gallon mix for problem #2, how much cement will be needed? How much fine aggregate, how much coarse aggregate, and how much water will be needed?

$$\begin{array}{r}
 6.25(\text{bags of cement}) \times 7.5(\text{cu. yds.}) = 46.875 \text{ bags of cement} \\
 14(\text{cu. ft.}) \times 7.5(\text{cu. yds.}) = 105 \text{ cu. ft. of fine aggregate} \\
 19(\text{cu. ft.}) \times 7.5(\text{cu. yds.}) = 142.5 \text{ cu. ft. of coarse aggregate} \\
 46.875(\text{bags}) \times 6(\text{gal. per bag}) = 281.25 \text{ gal. of water}
 \end{array}$$

# TOOLS USED IN CONCRETE WORK

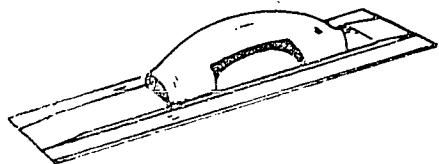

**Magnesium Float**

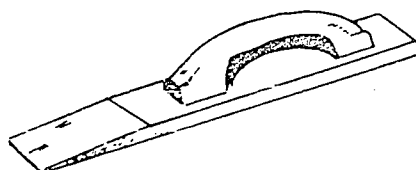

**Wood Float**

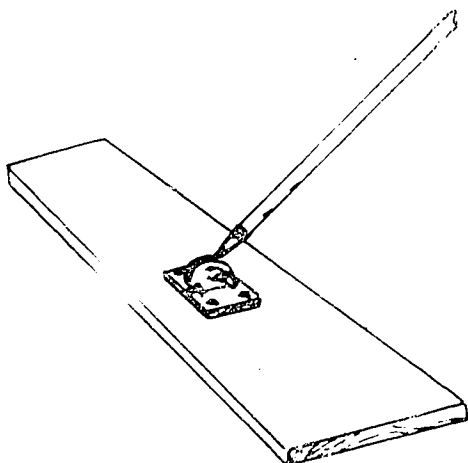

**Bullfloat**

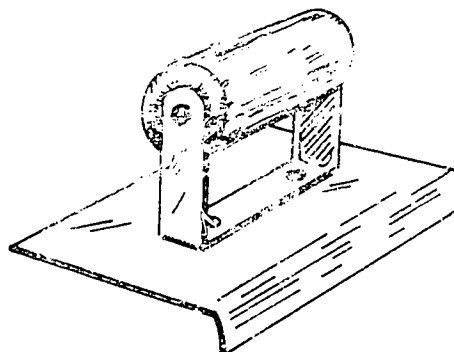

**Edger**

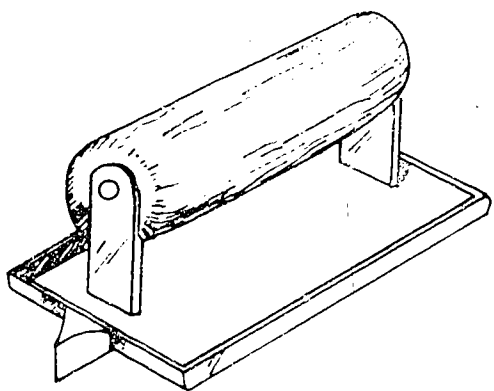

**Jointer or Groover**

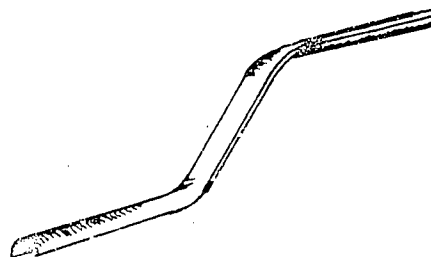

**Jointing Tool**

# TOOLS USED IN CONCRETE WORK

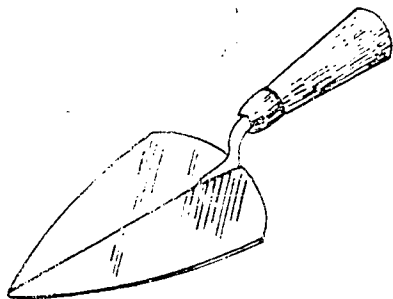

**Brick Trowel**

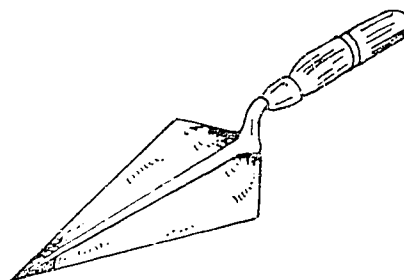

**Pointing Trowel**

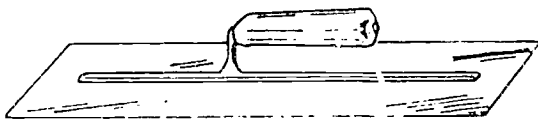

**Finishing Trowel**

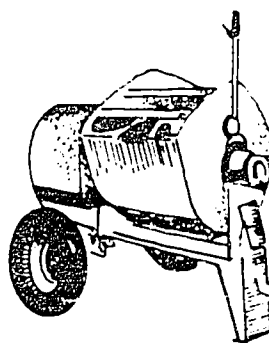

**Concrete Mixer**

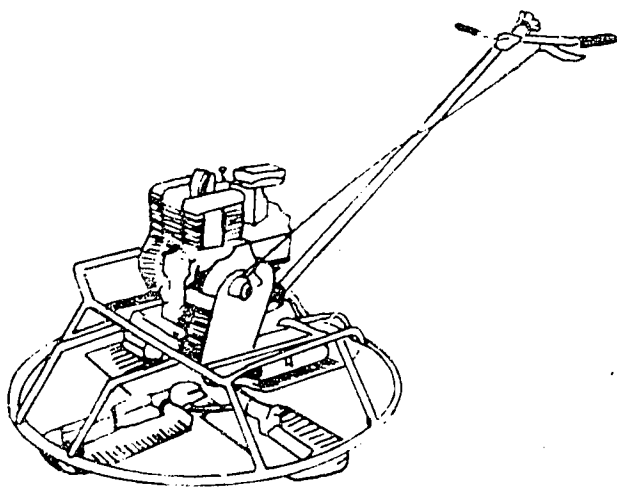

**Power Trowel**

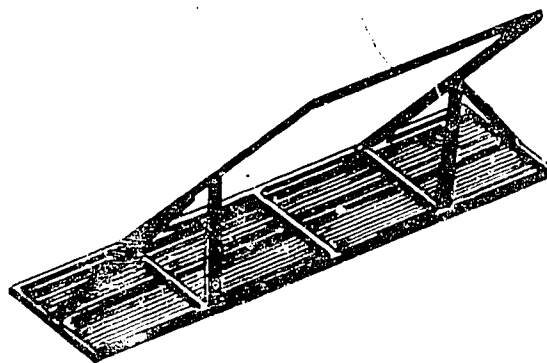

**Jitterbug**

# CONCRETE MIXING RATIO

## Foundation Footing and Walls

$$1 : 2\frac{3}{4} : 4 - 7$$



Parts  
(cu ft)  
of Cement



Parts  
(cu ft)  
of Sand

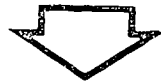

Parts  
(cu ft)  
of Aggregate



Gallons  
of Water

# CONCRETE MIXING RATIO

## Water-tight floors and Foundations

**1 : 2<sup>1</sup>/<sub>4</sub> : 3 - 6**



Parts  
(cu ft)  
of Cement



Parts  
(cu ft)  
of Sand

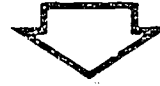

Parts  
(cu ft)  
of Aggregate



Gallons  
of Water

# Lay Out Buildings First

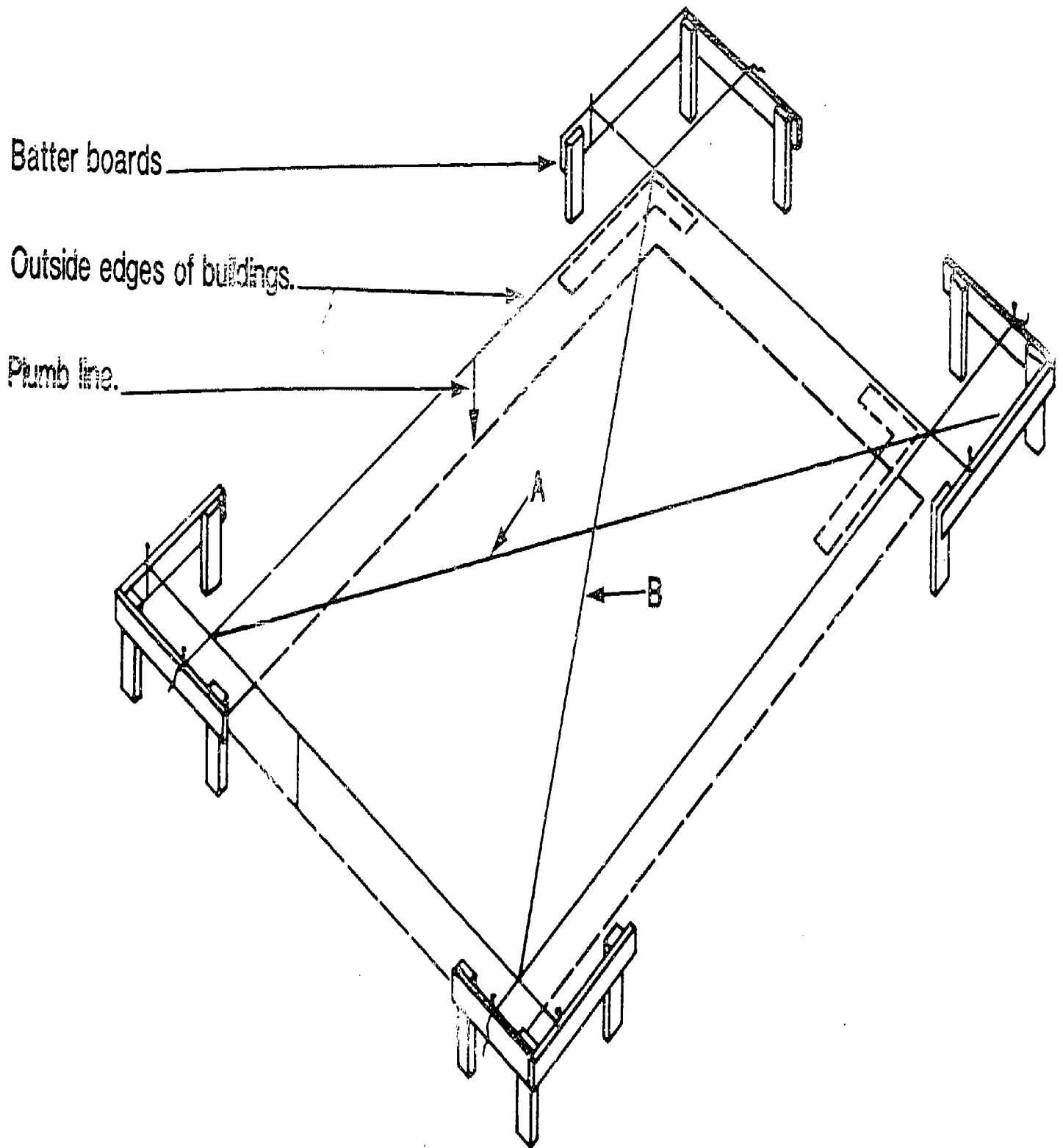

350

360

# CONCRETE FOOTING PLAN

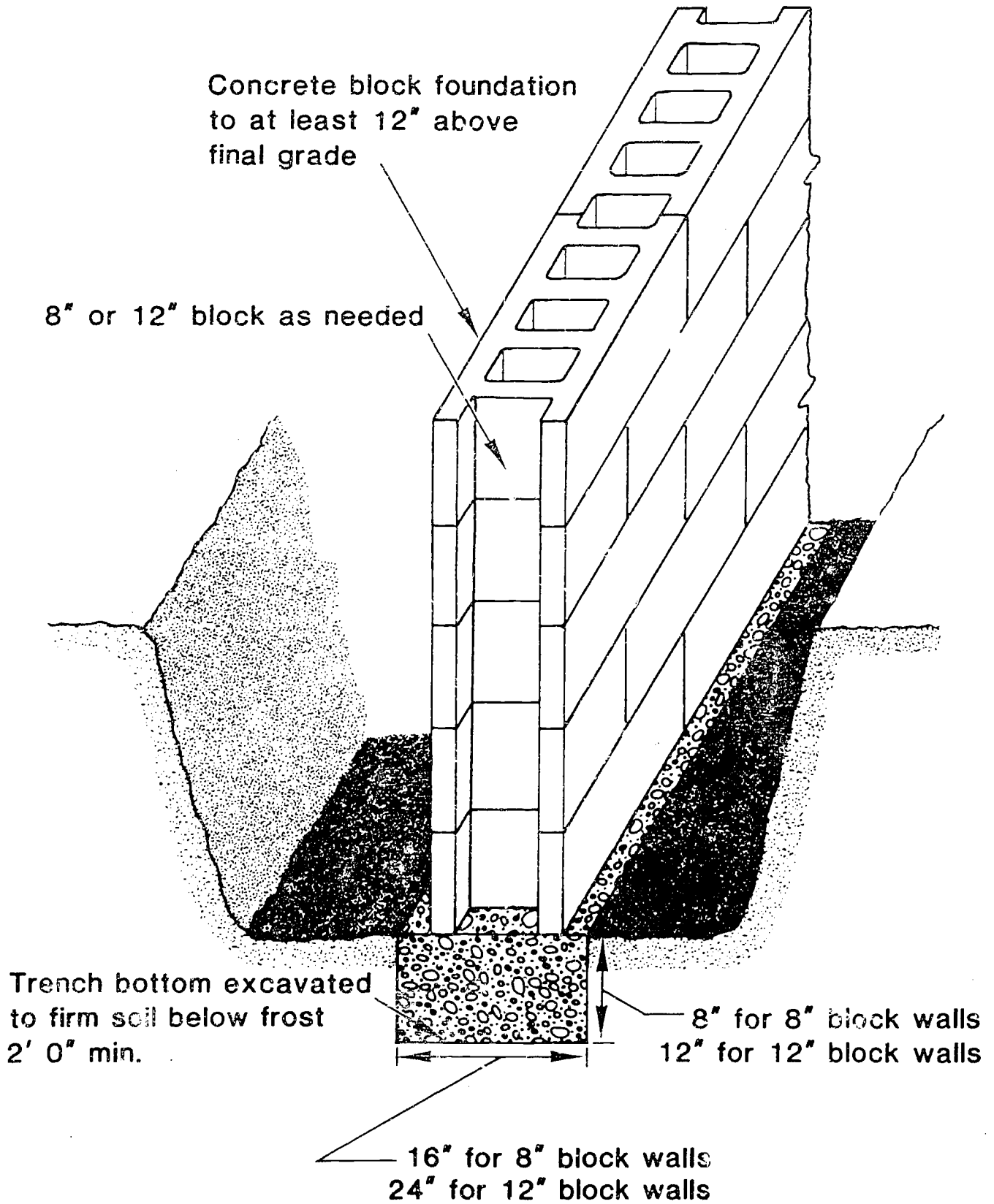

# Adequate Footings Essentials

1. Dig trench down to firm soil below frost.
2. Make bottom of trench flat and level.

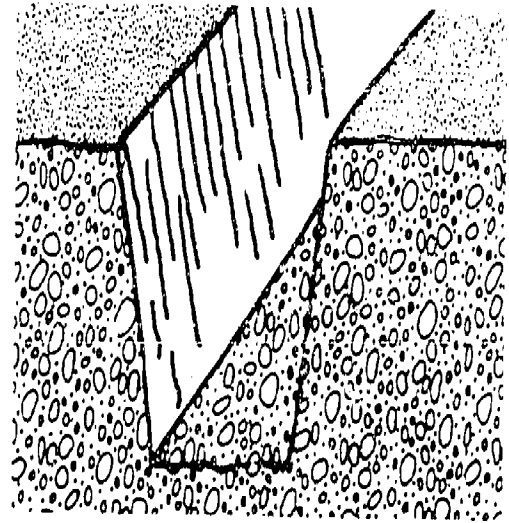

3. Forms to make footings proper size.

$W =$  Twice masonry wall thickness.

4. Fill with 1:2 3/4:4 concrete.

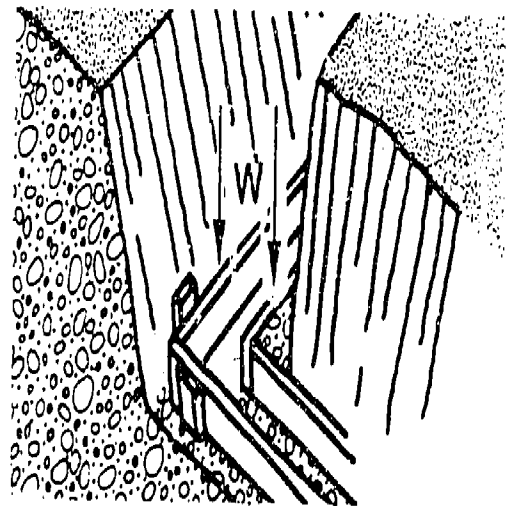

5. Remove form after concrete hardens.

6. Sweep off top of footing before laying concrete masonry.

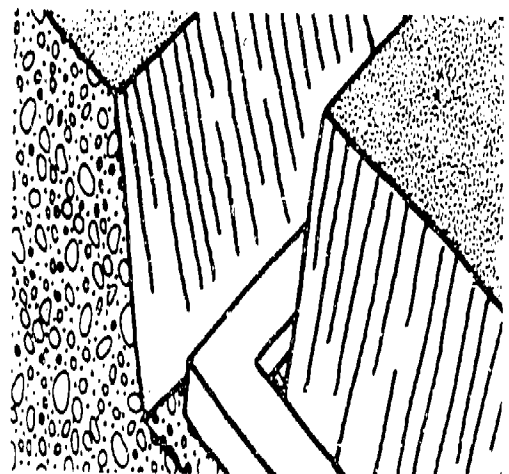



# Placing Block

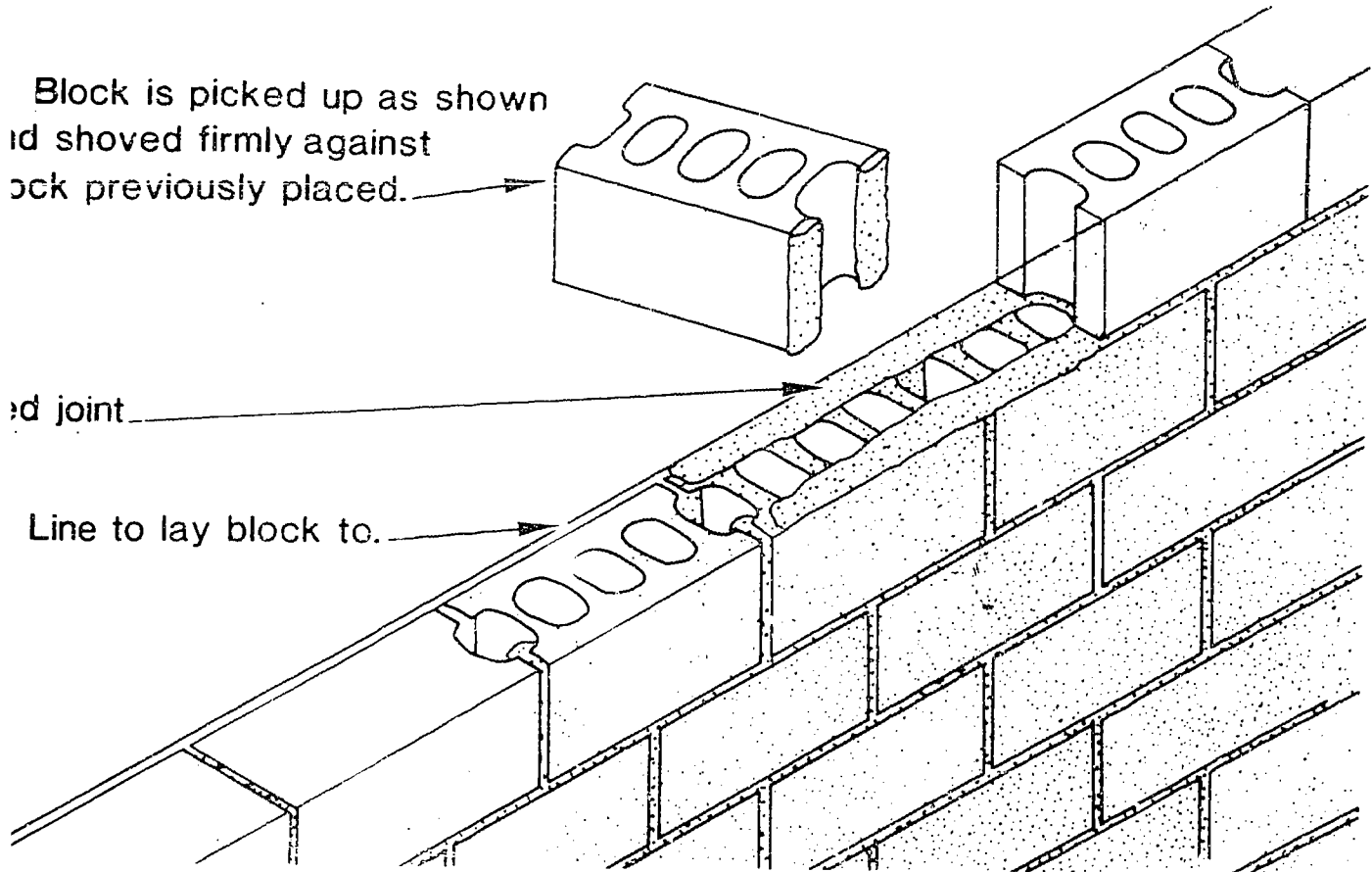

# Setting Block

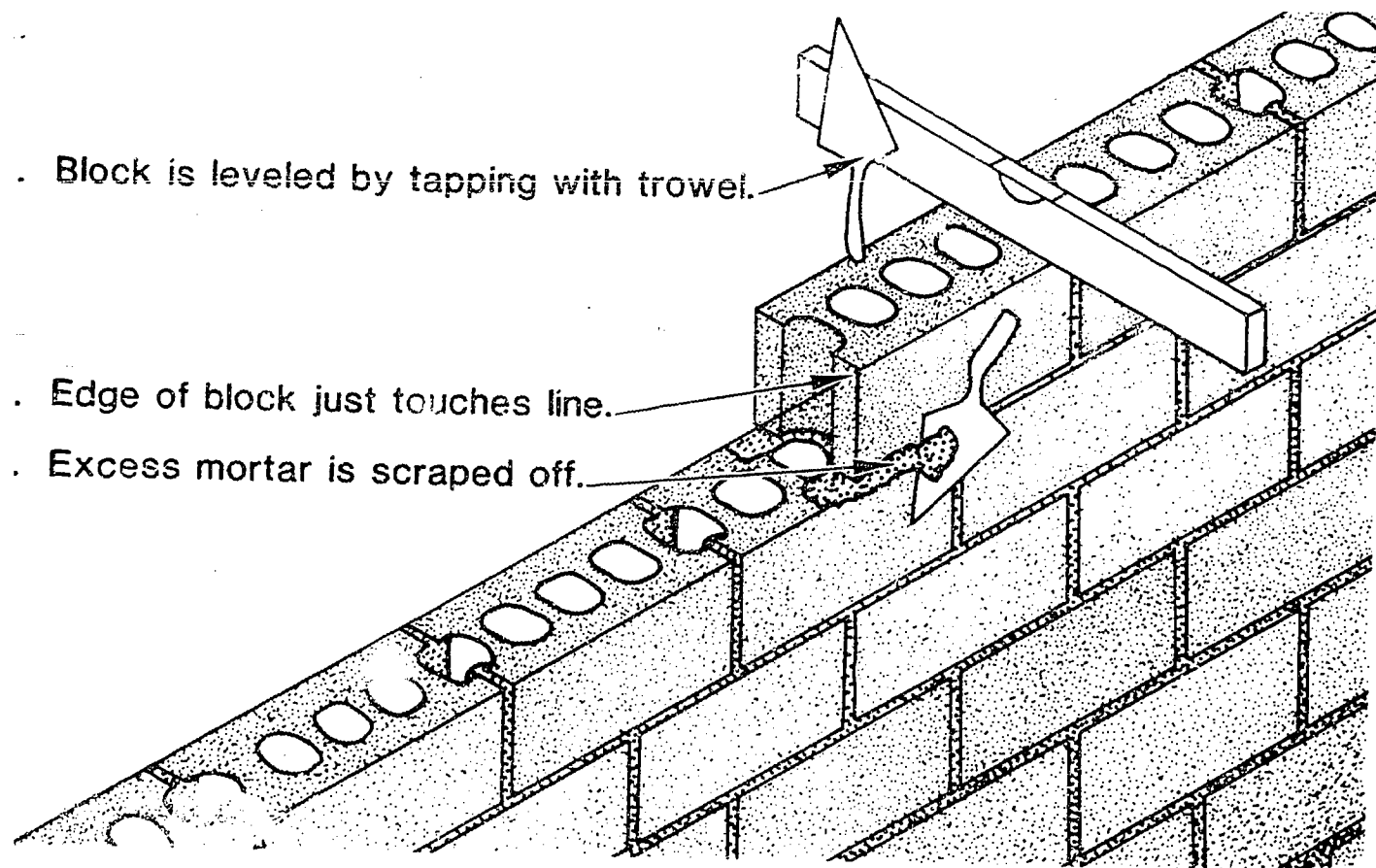

# Start Laying Block at Corners

1. Place mortar full width on footing.
2. Use corner block with one flat end at corners.
3. Mortar placed on face shells only for succeeding courses.
4. Make height of wall to fit concrete masonry unit.  
1 block and 1 horizontal joint equal 8".
5. Build corners up using mason's level to keep plumb and straight.

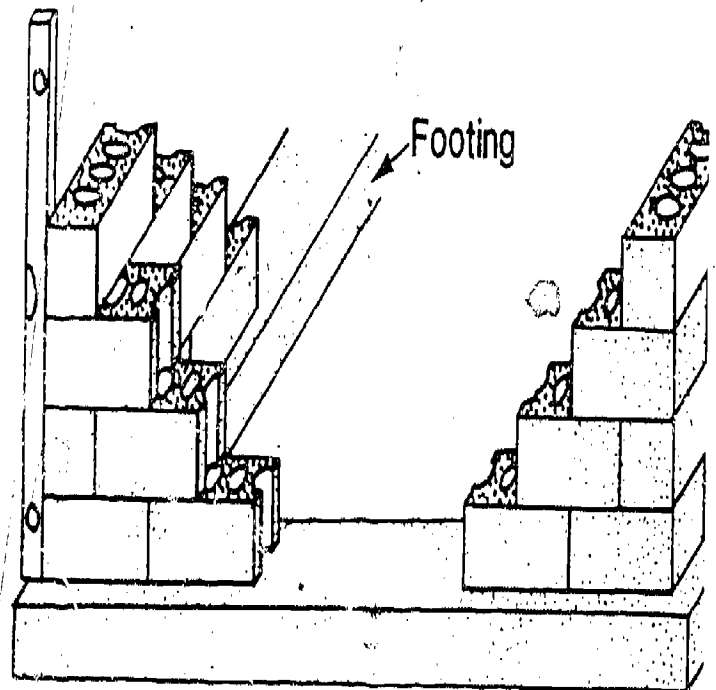
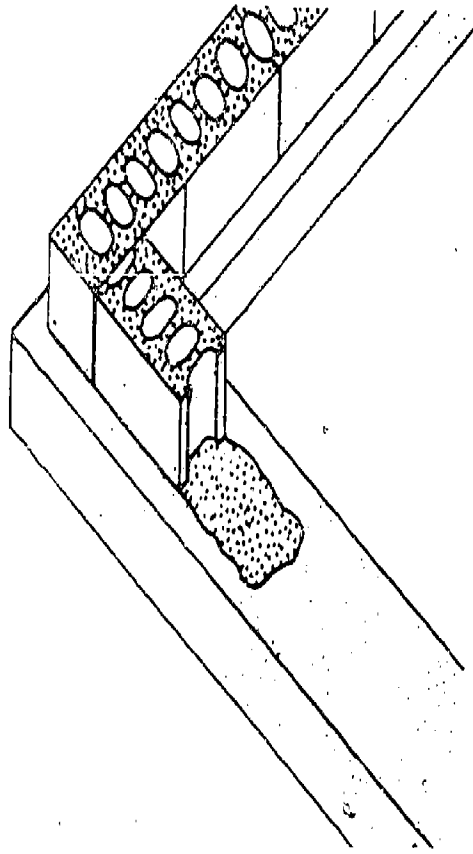

---

## Build Wall Between Corners

Stretch line between corners to lay block to.

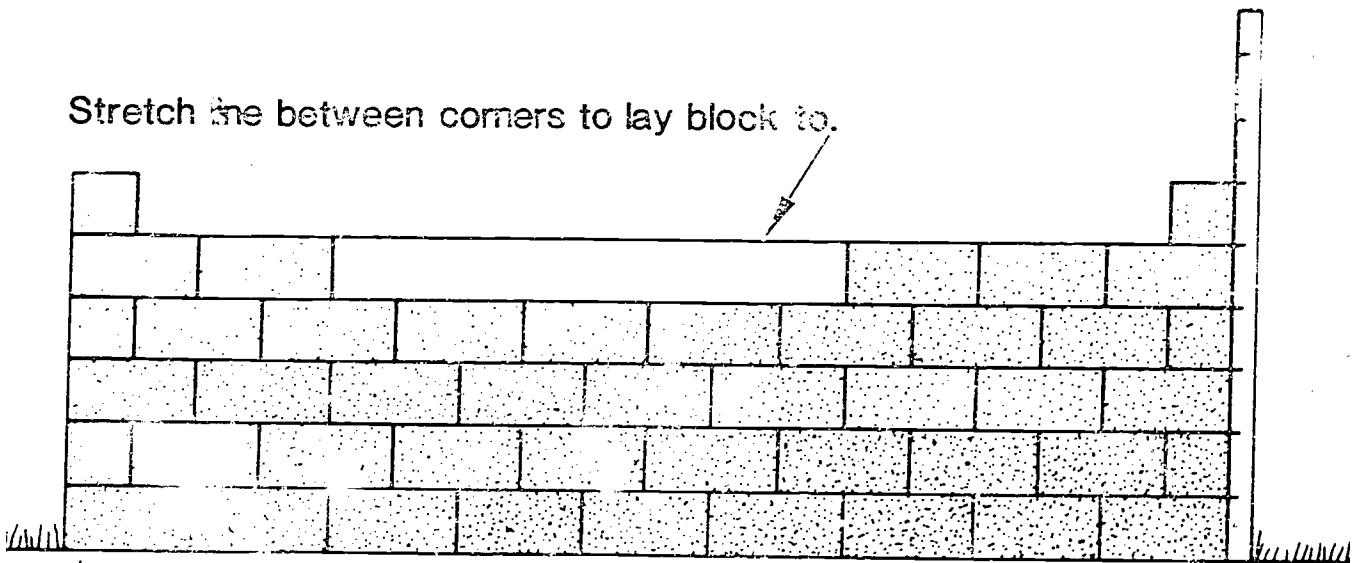

1" X 2" with saw marks 8" apart helps to space courses at corners.

Mortar joints are 3/8" thick.

Blocks should be dry when laid in wall.

# COMMON SHAPES AND SIZES OF CONCRETE BLOCKS

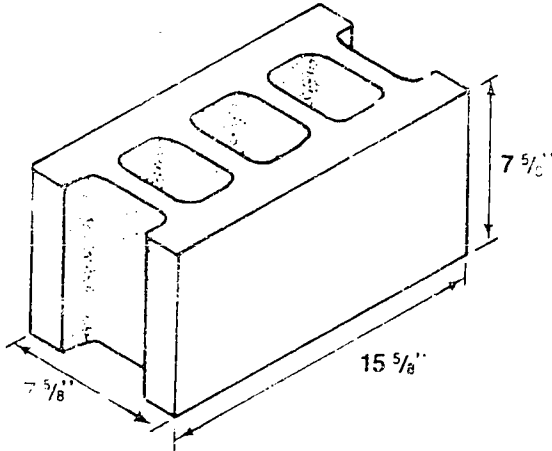

**Three Core Block**

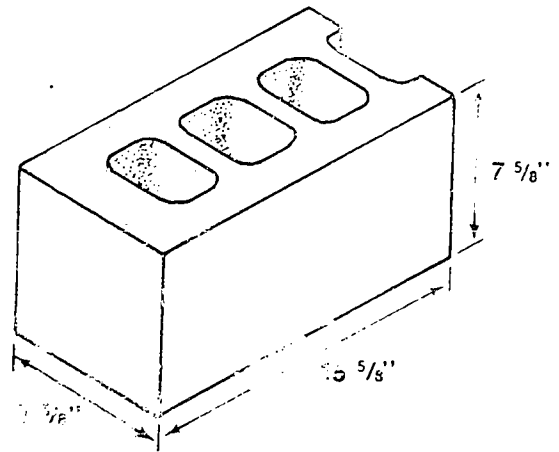

**Corner Block**

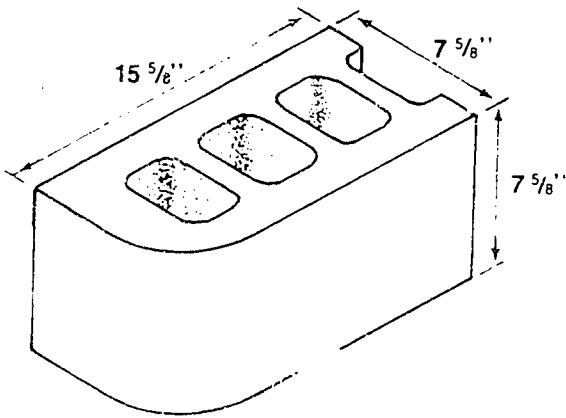

**Bullnose for Streamline Corners**

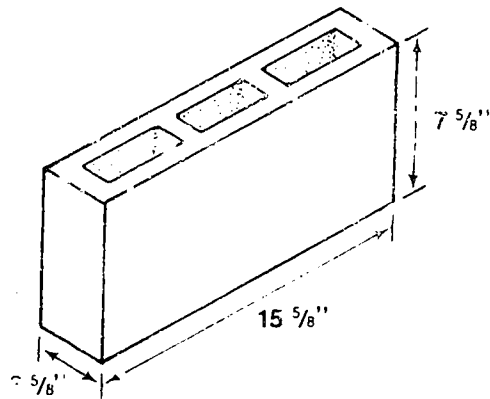

**Partition Block**

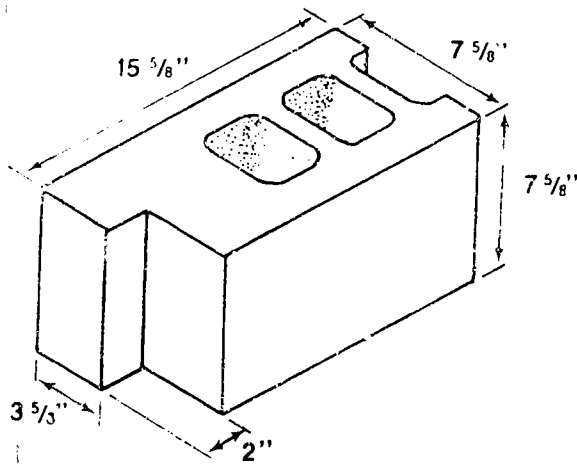

**Jamb Block**

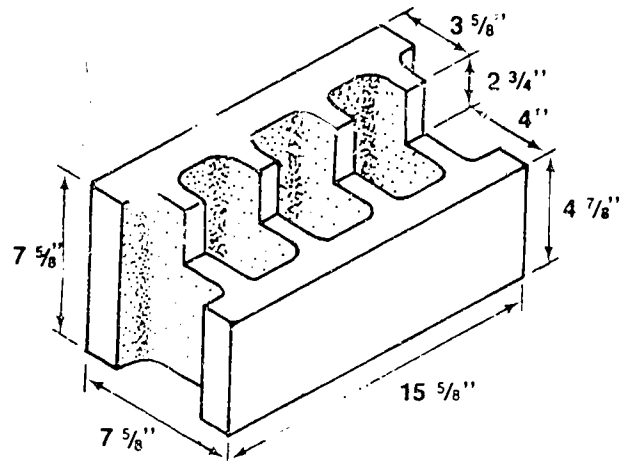

**Header Block**

# CONSTRUCTION OF A CONCRETE FORM

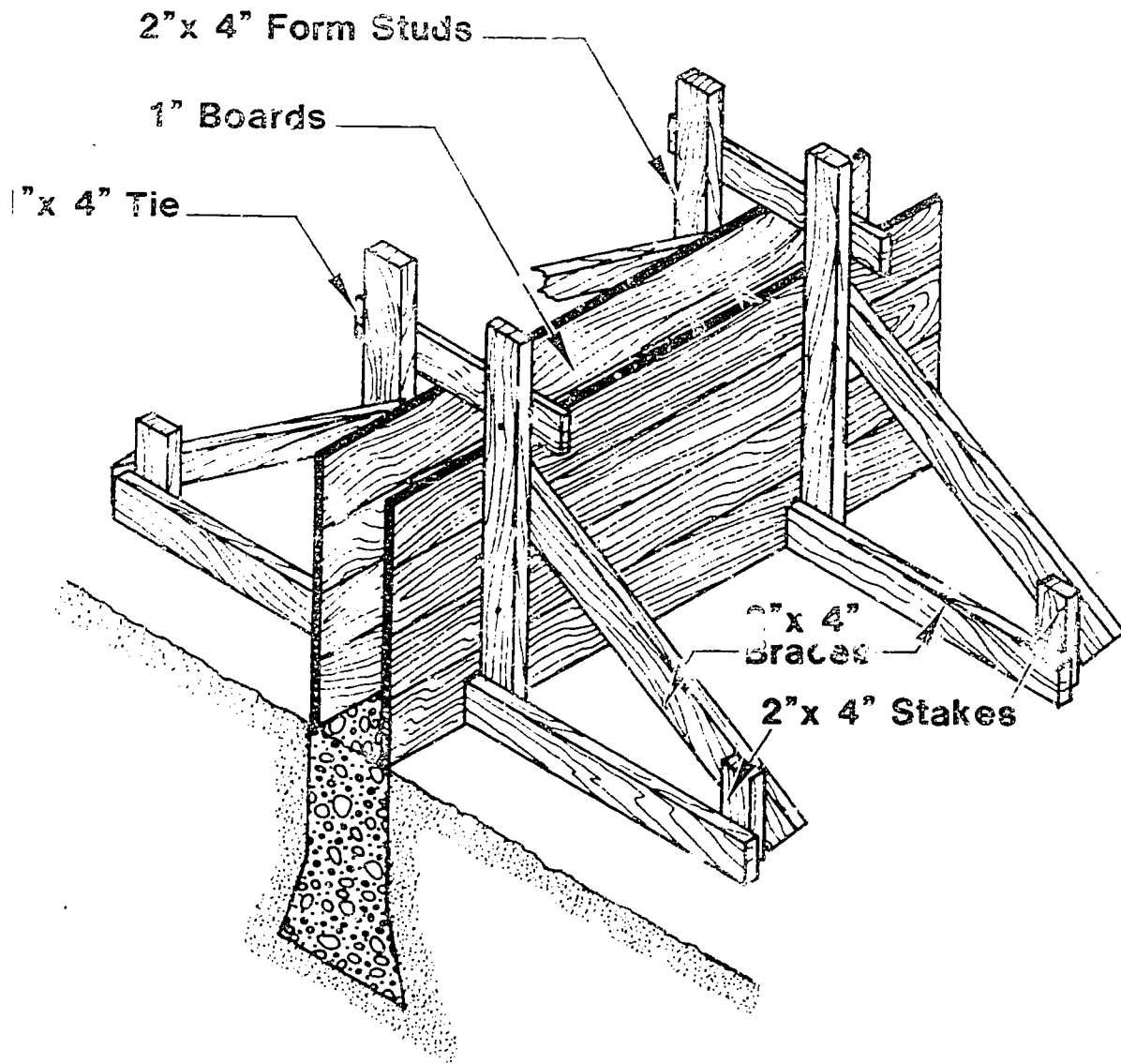

## TRANSPARENCY DISCUSSION GUIDE

### CONCRETE AND MASONRY WORK

#### I. Transparenciess--TOOLS USED IN CONCRETE WORK

- A. Use the transparenciess as a tool identification exercise. Cover up the names and see if students can identify each tool.
- B. Ask students to explain the purpose or use of each tool.
  1. Magnesium float--a tool used in the floating of fresh concrete. Floating is a process used with freshly placed concrete to produce a compacted surface free of voids and air pockets and to level concrete or bring it to proper grade.
  2. Wood float--same as above.
  3. Bullfloat--same as above.
  4. Edger--a tool used in the edging process before concrete hardens. Edging prevents chipping when removing forms and gives the edges a chip-free surface.
  5. Jointer--a tool used to make joints or grooves in a slab of concrete. This causes cracking to remain in the jointed groove instead of irregular cracking in other areas of the slab.
  6. Jointing tool--a tool used to smooth joints or to clean excess mortar from masonry construction.
  7. Brick trowel--a hand tool used to mix, apply, or smooth concrete or mortar.
  8. Pointing trowel--a hand tool used to mix, smooth, or apply concrete or mortar.
  9. Finishing trowel--a hand tool used to finish concrete where a smooth, dense surface is desired.
  10. Concrete mixer--a piece of equipment used to mix large quantities of concrete.
  11. Power trowel--a piece of equipment used to finish concrete after it is firm.
  12. Jitterbug--a hand tamper used to consolidate concrete that has a low slump (low setting rate).

II.      Transparenciess--CONCRETE MIXING RATIO

- A.    Read captions on transparencies and explain them to the class.
- B.    Ask class to define a cubic foot.
- C.    Ask class how they would measure a required amount of sand or aggregate.

III.     Transparency--LAY OUT BUILDING FIRST

- A.    The easiest, quickest and most accurate way to lay out the corners of a building is with surveying instruments.
- B.    An alternate way is the right-triangle method.
- C.    First, establish a base line and mark out one side or one end of the building.
- D.    Put up batter boards at corners.
- E.    Carpenter's square may be used in laying out approximate corners.
- F.    When length A equals length B the corners are square when opposite sides are equal.
- G.    Make length of wall to fit concrete masonry unit. One block and one vertical joint equal 16".

IV.     Transparency--CONCRETE FOOTING PLAN

- A.    Footing must be placed below frost line.
- B.    Soil at bottom of trench must be firm.
- C.    Point out to class how wide and thick footings should be for 8" and 12" blocks.

V.      Transparency--ADEQUATE FOOTINGS ESSENTIAL

- A.    It is a recommended practice to place concrete footings for all types of foundation walls. Such footings provide an even surface on which to start the wall.
- B.    Footings provide increased bearing area on the soil, thus insuring against settling. For buildings such as houses and one- and two-story buildings erected on soils of average load-carrying capacity, the concrete footing is generally made twice as wide as the thickness of the wall it supports. The depth of the footing is usually one-half its width or equal to the thickness of the wall. Thus, for a building with an 8-inch wall,



the footing is made 16 inches wide and 8 inches deep, and for a building with a 12-inch wall the footing is made 24 inches wide and 12 inches deep.

- C. In designing footings for heavy buildings, the weight of the building and its contents are computed, and the footings are made wide enough to carry the load. The carrying capacity of soils varies considerably and this is also taken into account in designing footings. Soft clay, for example, has a carrying capacity of 1 ton per square foot; hard dry clay will carry 4 tons per square foot; and gravel 6 tons per square foot.
- D. Footings are usually placed below grade (top of the soil) in order to be on firm soil. In areas where the ground freezes, the footings should be below frost penetration so that freezing will not heave the land and cause the walls to crack.
- E. The bottom of the footing should be flat, not rounded so the trench should be flat and level on the bottom. Forms for footings are usually made of lumber that is 2 inches thick and are held in place with stakes driven along the outside as shown in the center illustration. The stakes are placed close enough together so that the form will not bulge when filled with concrete.
- F. The recommended mixture for concrete footings is 5½ gallons of water to a sack of Portland cement when using average wet sand. If well-graded sand and gravel are available, about 2 ¾ cubic feet of sand and 4 cubic feet of gravel (graded from 1½ inches in size down) will make a satisfactory mix. The proportion of sand and gravel can be varied to make a workable mushy mix but the amount of water per sack of cement should not be changed. Forms are removed after the concrete hardens.

The top of the footing must be swept off to remove chips of concrete, dirt, loose rocks, etc., before laying concrete masonry.

#### VI. Transparency--PLACING BLOCK

- A. Point out the Mason's line and the mortar.
- B. Describe how block should be picked up and placed.

#### VII. Transparency--SETTING BLOCK

- A. Identify or have students identify tools shown on transparency.
- B. Mortar squeezed out of the joints is carefully scraped off with a trowel and applied on the other end of the block thrown back on the mortar board for later use.

- C. The blocks are laid to touch the line and are tapped with the trowel to get them straight and level. The joints should be  $\frac{3}{8}$  inch thick.

VIII. Transparency--START LAYING BLOCK AT CORNERS

- A. The customary practice is to lay up corners three or four courses high and use them as guides for laying walls.
- B. Place a full width of mortar on the footing. Build the first course out 2-3 blocks long each way from the corner. The second course is a half block shorter than the first course on each end and the third, a half block shorter than the second. The corners are stepped off until only one corner block is laid. Use a level frequently to be sure the blocks in the corners are level and plumb.

IX. Transparency--BUILD WALL BETWEEN CORNERS

- A. Stretch a heavy cord from corner to corner to serve as a guide for laying block between corners. Fasten the cord to nails or wedges in the mortar joints at the corners. Some masons use a "U" shaped plywood holder with the openings in the "U" just slightly larger than the width of the block so the tension of the string draws it tight.
- B. Stretch the cord so it just touches the upper, outer edges of the block laid in the corners.
- C. Lay the blocks in the wall so they touch the cord in the same manner. In this way the horizontal joints are obtained and these straight horizontal courses are one indication of good workmanship.

X. Transparency--COMMON SHAPES AND SIZES OF CONCRETE BLOCKS

- A. Show class one block at a time, covering others so they can focus their attention.
- B. Point out distinguishing characteristics of each block.
- C. Point out where each block would be used.

XI. Transparency--CONSTRUCTION OF A CONCRETE FORM

- A. Review importance of proper bracing.
- B. Refer to Question 16 in Sample Test Questions included with this problem area to review the six requirements of a good form.

TEACHER'S KEY

TEST QUESTIONS

VAS 300's - CONCRETE IMPROVEMENTS

TRUE (+) - FALSE (0)

- +   1. Water that is used for making concrete should be free from oil, acid, or harmful amounts of dirt.
- 0   2. The words concrete and cement have the same meaning.
- 0   3. A slight amount of oil should be added to the mix when placing concrete in reusable forms.
- +   4. Exterior plywood, which is made with waterproof glue, is used to make forms by many contractors.
- 0   5. A control joint is used to separate floors from points of abutment with walls or columns, whereas isolation joints are used to control cracking.
- +   6. To change the consistency of the concrete, vary the amounts of aggregate, not the water.
- +   7. A darby is used to float the surface of plastic concrete after it has been struck off.
- 0   8. A jointer is the same as an edger.
- +   9. If the relative humidity changes from 90% to 40%, the rate of water evaporation is increased nine times.
- 0   10. During cold weather it is advisable to use antifreeze to prevent concrete from freezing.

MULTIPLE CHOICE - CHOOSE BEST ANSWER

- C   1. Consistency of concrete is a measure of the \_\_\_\_\_ of the concrete when it is freshly mixed.
- A. mixture  
B. uniformity  
C. wetness or dryness
- C   2. 94 pounds of cement is equal to:
- A. 1 cubic meter in volume  
B. 1 cubic yard in volume  
C. 1 cubic foot in volume

- B 3. There is normally more \_\_\_\_\_ than \_\_\_\_\_ in a concrete mix.
- A. sand, gravel  
 B. gravel, sand  
 C. cement, sand
- A 4. A \_\_\_\_\_ is used where concreting stopped and later was started again.
- A. construction joint  
 B. isolation joint  
 C. control joint
- C 5. A deformed reinforcing bar is one that:
- A. has been warped due to expansion  
 B. has been curved for corner reinforcing  
 C. none of the above
- B 6. Reinforcing steel carries a \_\_\_\_\_.
- A. compressive load  
 B. tensile load  
 C. expansive load
- B 7. A vibrator should be:
- A. used to move concrete horizontally  
 B. used to consolidate  
 C. held against reinforcing steel
- A 8. A control joint is cut to a depth of \_\_\_\_\_ of the slab thickness.
- A. 1/5 to 1/3  
 B. 1/4 to 2/4  
 C. 3/4 or more
- D 9. The exact time it takes for the water sheen to disappear is indefinite because it depends upon:
- A. temperatures of concrete and air  
 B. wind  
 C. humidity  
 D. all of above
- A 10. A cubic yard is \_\_\_\_\_.
- A. 27 cu. ft.  
 B. 30 cu. ft.  
 C. the same as a cubic meter

## MATCHING

- |          |  |    |  |
|----------|--|----|--|
| <u>E</u> | 1. Concrete has many properties that make it a desirable building material and some of these are | A. | more workable, reduces bleeding                      |
| <u>J</u> | 2. The ingredients that make up concrete   | B. | tensile strength                                     |
| <u>A</u> | 3. Some of the advantages of using air-entrainment in concrete                                   | C. | control joint  |
| <u>H</u> | 4. Increase in volume of sand due to the addition of water                                       | D. | crazing  |
| <u>C</u> | 5. Predetermined location of a crack   | E. | moldable, storm resistant,                           |
| <u>G</u> | 6. A natural strength of concrete  | F. | curbing  |
| <u>B</u> | 7. Strength in concrete that is not natural but comes with the addition of reinforcement         | G. | compressive strength                                 |
| <u>K</u> | 8. Used to float the surface of concrete after it has been struck off                            | H. | bulking  |
| <u>D</u> | 9. Problem due to rapid drying of concrete   | I. | walk-behind float                                    |
| <u>F</u> | 10. Process that occurs best when concrete is kept cool and moist for at least a week            | J. | portland cement, coarse and fine aggregate and water |
|          |  | K. | bull float   |

## COMPLETION

1. Concrete is a mixture of inert materials that are combined with a paste of cement and water.
2. A 6" thick floor for a 30 foot by 40 foot building would require 22.2 cubic yards of concrete.
3. An edger is used to round off exposed edges to prevent them from cracking.
4. It is customary to oil the forms that come in contact with the concrete to prevent sticking.
5. A control joint is required to relieve tensile stress or undesirable cracks will develop.
6. The bubbles are so minute that there are billions of them in a cubic foot (Ft<sup>3</sup>) of air-entrained concrete.
7. Increasing the amount of water used in a concrete mixture will drastically reduce the strength of the concrete.
8. It is necessary to accurately measure the materials used when mixing concrete.
9. A form must be substantial enough to retain its correct shape when filled with concrete.

10. Floating is the finishing process started after the water sheen has disappeared from the surface of the concrete.

#### ESSAY QUESTIONS

1. List the principal factors that determine the strength and other qualities of concrete.

(answer, 3rd paragraph, p. 5 of VAS Unit 3007a)

2. How can you meet the special problems of concrete work in off-season?

(answer, 4th paragraph, right column, p. 18 of VAS Unit 3007a)

TEACHER'S KEY  
SAMPLE TEST QUESTIONS  
CONCRETE AND CONCRETE BLOCKS

1. What are the dimensions of an ordinary 3 core block?  
7 5/8" x 7 5/8" x 15 5/8"
2. What does a heavyweight unit weigh?  
40 - 50 lbs.
3. What does a lightweight unit weigh?  
25 - 35 lbs.
4. List 5 reasons why concrete masonry is a popular type of building construction.
  - A. Adaptable
  - B. Economical
  - C. Durable
  - D. Fire Resistant
  - E. Attractive
5. What is the primary function for a footing?  
To provide an even surface on which to start a wall.
6. If you are building an 8" wide block wall, how wide and deep should the footing be?
  - A. Width--16"
  - B. Depth--8"
7. List six factors that affect the strength of the bond.
  - A. Workability of mortar
  - B. Type and quantity of material
  - C. Surface texture of bedding area
  - D. Rate of suction of mortar joints
  - E. Water retentivity of mortar
  - F. Quality of workmanship
8. List two reasons why mortar joints should be tooled.
  - A. Compacts the mortar and pushes it to both sides of the joint.
  - B. Produces joints with uniform appearance.

9. Define the following terms:
- Workability of mortar--Plasticity of the mortar.
  - Water retentivity of mortar--Ability of mortar to retain moisture.
  - Mason's line--String attached from corner to corner to assist in laying blocks.
  - Retempering mortar--Adding water to mortar to bring it back to workability.
  - Story pole--Sticks with marks every 8" to assist in laying blocks.
10. What are the three components of concrete?
- Portland cement
  - Water
  - Aggregates
11. What are 10 advantages for concrete as a building material?
- |                            |               |
|----------------------------|---------------|
| A. Firesafe.               | F. Permanent. |
| B. Strong                  | G. Watertight |
| C. Resists abrasion        | H. Sanitary   |
| D. Insect and rodent proof | I. Economical |
| E. Storm resistant         | J. Moldable   |
12. What are the two rules of thumb that determine maximum size of aggregate that can be used?
- Aggregate can be no larger than 1/3 to 1/5 thickness of concrete to be poured.
  - Aggregate can be no larger than 3/4 the size of the smallest opening through which the concrete is to be placed.
13. What are the three properties of concrete which will greatly influence the quality of hardened concrete?
- Consistency
  - Uniformity
  - Workability



14. What is the principal factor that determines the strength, watertightness and durability of concrete?  
Water-cement ratio
15. What is the ratio of cement to fine aggregate to coarse aggregate in a 6-gallon mix?  
1:2½:3
16. What are the six requirements for a proper form?  
A. Substantial enough to retain proper shape  
B. Rigid  
C. Strong  
D. Tight  
E. Easily filled  
F. Easily removed
17. What are the three types of joints commonly used when pouring floors and slabs?  
A. Isolation joints  
B. Control joints  
C. Construction joints
18. What happens if fresh concrete is overworked?  
Water, cement paste, and fine aggregate will move to the surface leading to a dusting and scaling of the surface.
19. Why should reinforcing steel be used in concrete?  
A. To allow concrete to withstand tension  
B. To increase tensile strength
20. What are six of the steps in finishing?  
A. Consolidation  
B. Striking off  
C. Darbying  
D. Floating  
E. Jointing  
F. Finishing
21. What are six types of finishes?  
A. Broom finish  
B. Belt finish  
C. Hand float finish  
D. Steel trowel finish  
E. Power trowel finish  
F. Exposed aggregate finish

22. Define the following terms:

- A. Concrete--Concrete is an artificial stone composed of Portland cement, sand, gravel or broken stone and water.
- B. Portland Cement--Portland Cement is a manufactured product produced by burning lime, silica, iron oxide, and alumina. The resulting clinker is ground so that 90% will pass through a 200 mesh screen.
- C. Course Aggregate--Consists of gravel, crushed stone or similar material larger than  $\frac{1}{4}$ " inch particle size.
- D. Fine Aggregate--Consists of sand and smaller gravel and crushed stone smaller than  $\frac{1}{4}$ " inch particle size.
- E. Form--A mold or receptacle into which concrete mixture is placed so that it will have the desired shape when hardened.
- F. Curing--Process of concrete hardening to to hydration.

## UNIT I: AGRICULTURAL BUSINESS MANAGEMENT

### PROBLEM AREA: FOUR WAYS OF DOING BUSINESS IN AGRICULTURE

#### SUGGESTIONS TO THE TEACHER:

This problem area is designed to provide junior or senior students with a background in how business operates in a free enterprise system. All students need to know how American businesses are organized and operated. As you discuss this subject with your class, do not leave farms out of your discussion because they represent the largest and most important example of the sole proprietorship and partnership form of business in many communities.

Approximately one week of instructional time should be scheduled for this problem area. It can be taught at any time during the academic year and can be incorporated into a farm management or an agricultural business management course.

Teachers should order the necessary instructional materials from Vocational Agriculture Service and supplement them with other materials from local cooperatives or other sources. If the films are to be borrowed from the Grange Farm Film Foundation, they should be booked early in the school year.

#### CREDIT SOURCES:

These materials were developed through a funding agreement, R-33-13-D-0362-466, with the Illinois State Board of Education, Department of Adult, Vocational and Technical Education, Research and Development Section, 100 North First Street, Springfield, Illinois 62777. Opinions expressed in these materials do not reflect, nor should they be construed as policy or opinion of the State Board of Education or its staff.

The teacher's guide, student worksheet, and test questions were developed by Lee West, Vocational Agriculture Teacher. Mt. Pulaski High School, Mt. Pulaski, Illinois and Paul Hemp, Department of Vocational and Technical Education, University of Illinois. This problem area was reviewed by the following vocational agriculture teachers:

Lee West	-	Mt. Pulaski High School
Ron Welling	-	Pecatonica High School
Jim Guilinger	-	Sycamore High School

## TEACHER'S GUIDE

- I. Unit: Agricultural business management
- II. Problem area: Four ways of doing business in agriculture
- III. Objectives: At the close of this problem area, students will be able to:
  1. Identify types of agricultural business ownership.
  2. Explain different procedures of stock voting.
  3. Differentiate between partnerships and proprietorships.
  4. Differentiate between corporations and cooperative corporations.
  5. Identify local businesses as one of the four types of businesses.
  6. Identify advantages and disadvantages of the four ways of doing business.
- IV. Suggested interest approaches:
  1. Discussion: How are various local businesses owned?
    - a. What are some common corporations in agriculture.
    - b. What are some cooperatives in agriculture?
    - c. Does anyone have a partnership in their S.O.E.P.? If so, how is its ownership different than a sole proprietorship?
    - d. Can farms incorporate?
    - e. What co-op activities can FFA chapters conduct?
  2. Show the film "How People do Business in our Democracy" or "Cooperatives--The Farmers' Way" available on a free loan basis from the Grange Farm Film Foundation (See Section IX for address).
- V. Anticipated problems and concerns of students:
  1. What are the different ways of doing business?
  2. What is a partnership? a corporation? a cooperative?
  3. What are the distinguishing characteristics of each type of business organization?

4. What businesses in our community are corporations, co-ops, sole proprietorships, partnerships?
5. How is a corporation owned?
6. How do partnerships work?
7. How is stock voted in a corporation? In a co-op corporation?
8. Can a partnership be formed without one of the parties knowing it?
9. What resources are needed to operate any business?
10. What are the advantages and disadvantages of the following:
  - sole proprietorships
  - partnerships
  - corporations
  - cooperatives
11. How do these four types of businesses differ with respect to:
  - Method of finance.
  - How managed.
  - How voting is done.
  - How profits are used.
  - Owners' liability.
12. How does the federal and state governments control or regulate business activities?

VI. Suggested learning activities and experiences:

1. Conduct an interest approach to introduce this problem area and to motivate students' interest.
2. Develop instructional objectives with the class.
3. Have students identify a list of problems and concerns. Assume that the class members wish to start a business venture and are not sure which type of business to establish. Use lead question "What do we need to know about the four ways of doing business in order to make a wise decision?"
4. Conduct supervised study. Have students search out answers after reading VAS Unit 6014 and 6013.
5. Have students complete the student worksheets included with this problem area.

6. Use VAS Slidefilms 393, 394, & 395 to provide additional information for answering questions and to build a knowledge base for this problem area.
7. Invite in or visit an owner or manager representing one or more of the four ways of doing business to explain how these types of business organizations function.
8. Use the overhead projector to diagram a chart showing the differences in the four types of business organization. Use the transparency showing the organization chart of a corporation.
9. Have student draw an organization chart for the other types of businesses.
10. Hold mock corporate director and officer elections with varying amounts of stock.
11. Hold mock co-op director and officer elections with varying amounts of stock.

VIII. Application procedures:

1. Discuss with class the opportunities they have to use a partnership arrangement with their S.O.E. program.
2. Organize a cooperative or a corporation within the FFA chapter.
3. Organize co-op sales of garden seed, pencils, bulbs or other items suited to the local chapter interests.
4. Organize a chain gilt program or co-op sheep enterprise or chain beef heifer program.
5. Purchase feeder cattle or hogs cooperatively and disperse small lots to students to finish out and reassemble for marketing.

VIII. Evaluation:

1. Administer a pencil and paper test to test students' knowledge of this problem area.
2. Collect and evaluate student worksheets.

I X. References and aids:

1. VAS Unit 6014, "Common Ways of Organizing a Business."
2. VAS Unit 6013, "Business Under Capitalism and Other Systems."

3. VAS Slidefilm 393 and Cassette Tape, "American Private Enterprise System."
4. VAS Slidefilm 394 and Cassette Tape, "Cooperative-Distinctive Business Corporation."
5. VAS Slidefilm 395 "Farmer Cooperatives--U.S. and Illinois."
6. Free loan films available from the Grange Farm Film Foundation, 1616 H Street, N.W., Washington, D.C. 20006:

"How People Do Business in our Democracy"  
"Cooperatives--The Farmers' Way"

387

## STUDENT WORKSHEET

### COMMON WAYS OF ORGANIZING A BUSINESS

1. What are the four different types of business organizations?
2. What are the advantages and disadvantages of each type?
3. What are the characteristics of each type of business organization?
4. What is the meaning of the following terms?
  - legal person--
  - charter--
  - consumer cooperative--
  - corporation--
  - patron--
  - purchasing cooperative--
5. What are the four categories of resources needed to operate a business?
6. What are some major roles of government in business activities?



STUDENT WORKSHEET

COMPARISON OF FOUR TYPES OF BUSINESS

Compare the four common types of businesses by writing in the business-type for each feature or method listed. The business types are individual, partnership, corporation or cooperative.

1. Who uses the services?  
Non-owner customers \_\_\_\_\_  
Generally non-owner customers \_\_\_\_\_  
  
Chiefly the owner patrons \_\_\_\_\_
2. Who owns the business?  
An individual \_\_\_\_\_  
Stockholders \_\_\_\_\_  
Member-patrons \_\_\_\_\_  
Partners \_\_\_\_\_
3. Who votes?  
Common stockholders \_\_\_\_\_  
Partners \_\_\_\_\_  
Member-patrons \_\_\_\_\_  
None necessary \_\_\_\_\_
4. How is voting done?  
One member-one vote \_\_\_\_\_  
None necessary \_\_\_\_\_  
Shares of common stock \_\_\_\_\_  
Partner's share of capital \_\_\_\_\_
5. Who determines policies?  
The partners \_\_\_\_\_  
Stockholders and directors \_\_\_\_\_  
Member patrons and directors \_\_\_\_\_  
Owner \_\_\_\_\_
6. Are returns on ownership capital limited?  
No \_\_\_\_\_  
  
Yes \_\_\_\_\_
7. Who gets the operating proceeds?  
Stockholders \_\_\_\_\_  
Owners in proportion to \_\_\_\_\_  
interest in business \_\_\_\_\_  
Single owner \_\_\_\_\_  
Patrons on a patronage basis \_\_\_\_\_

STUDENT WORKSHEET

LOCAL SURVEY OF BUSINESS TYPES

Identify 20 businesses in the local community and classify them as individually owned, partnership, corporation or cooperative. Be sure to include at least three examples of each type. Do not overlook farms as a type of business but include other types of businesses of an agricultural nature.

	<u>Name of Business</u>	<u>Type</u>
1.	_____	_____
2.	_____	_____
3.	_____	_____
4.	_____	_____
5.	_____	_____
6.	_____	_____
7.	_____	_____
8.	_____	_____
9.	_____	_____
10.	_____	_____
11.	_____	_____
12.	_____	_____
13.	_____	_____
14.	_____	_____
15.	_____	_____
16.	_____	_____
17.	_____	_____
18.	_____	_____
19.	_____	_____
20.	_____	_____

TEACHER'S KEY  
STUDENT WORKSHEET  
COMMON WAYS OF ORGANIZING A BUSINESS

1. What are the four different types of business organizations?

Individual proprietorship, partnership, corporation, and cooperative

2. What are the advantages and disadvantages of each type?

Refer to VAS Unit 6014.

3. What are the characteristics of each type of business organization?

See page 5 in VAS Unit 6014

4. What is the meaning of the following terms?

legal person--a characteristic of a corporation which means it is treated as a person by the law

charter--document granted by the state which defines purposes and limits the activities of a corporation

consumer cooperative--a cooperative which purchases and distributes goods and supplies

corporation--an entity created by law for business purposes

patron--those who patronize a cooperative

purchasing cooperative--a cooperative used by member patrons to purchase supplies on a cooperative basis

5. What are the four categories of resources needed to operate a business?

Land (natural resources), labor, capital, and management

6. What are some major roles of government in business activities?

Provide laws and regulations

Provide protection

Provide services

Create a legal climate for business to operate

TEACHER'S KEY  
STUDENT WORKSHEET

COMPARISON OF FOUR TYPES OF BUSINESS

Compare the four common types of businesses by writing in the business-type for each feature or method listed. The business types are individual, partnership, corporation or cooperative.

- |    |   |   |
|----|---|---|
| 1. | Who uses the services?<br>Non-owner customers<br>Generally non-owner customers<br><br>Chiefly the owner patrons                                     | <u>Individual</u><br><u>Partnership</u><br><u>Corporation</u><br><u>Cooperative</u> |
| 2. | Who owns the business?<br>An individual<br>Stockholders<br>Member-patrons<br>Partners   | <u>Individual</u><br><u>Corporation</u><br><u>Cooperative</u><br><u>Partnership</u> |
| 3. | Who votes?<br>Common stockholders<br>Partners<br>Member-patrons<br>None necessary   | <u>Corporation</u><br><u>Partnership</u><br><u>Cooperative</u><br><u>Individual</u> |
| 4. | How is voting done?<br>One member-one vote<br>None necessary<br>Shares of common stock<br>Partner's share of capital                                | <u>Cooperative</u><br><u>Individual</u><br><u>Corporation</u><br><u>Partnership</u> |
| 5. | Who determines policies?<br>The partners<br>Stockholders and directors<br>Member patrons and directors<br>Owner                                     | <u>Partnership</u><br><u>Corporation</u><br><u>Cooperative</u><br><u>Individual</u> |
| 6. | Are returns on ownership capital limited?<br>No<br><br>Yes  | <u>Individual</u><br><u>Partnership</u><br><u>Corporation</u><br><u>Cooperative</u> |
| 7. | Who gets the operating proceeds?<br>Stockholders<br>Owners in proportion to<br>interest in business<br>Single owner<br>Patrons on a patronage basis | <u>Corporation</u><br><u>Partnership</u><br><u>Individual</u><br><u>Cooperative</u> |

---

# WHAT IS A COOPERATIVE BUSINESS?

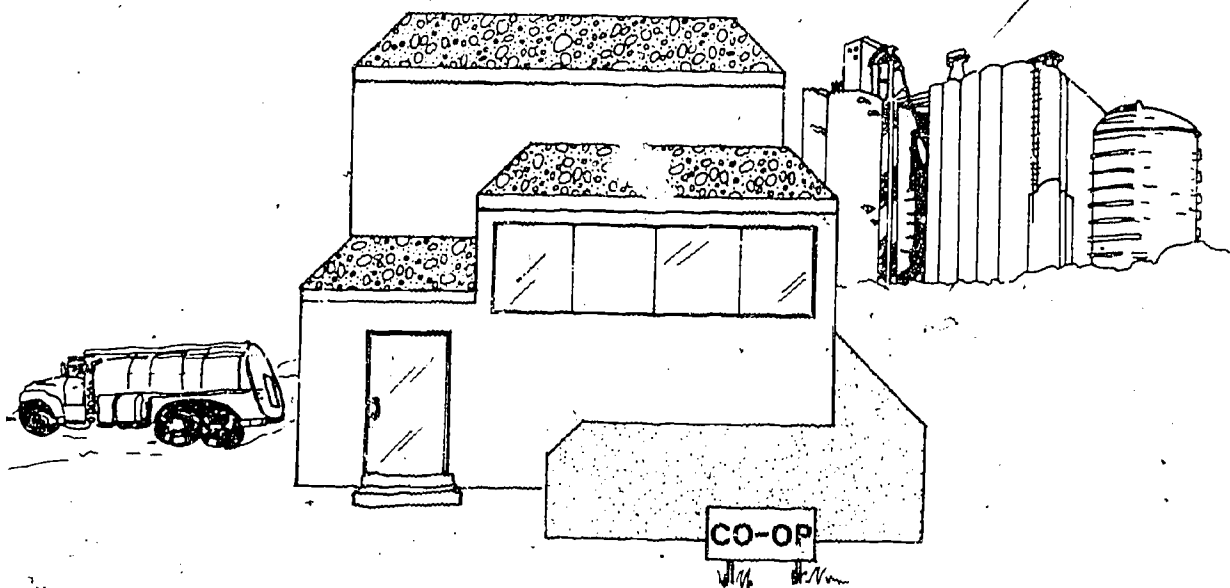

A cooperative business is a business voluntarily owned and controlled by its users and operated for them on a nonprofit basis.

---

# WHAT ARE THE DISADVANTAGES OF A COOPERATIVE?

- A. SOURCES OF FINANCING LIMITED
- B. NEED TO EDUCATE MEMBERS
- C. LIMIT IN SCOPE OF OPERATIONS

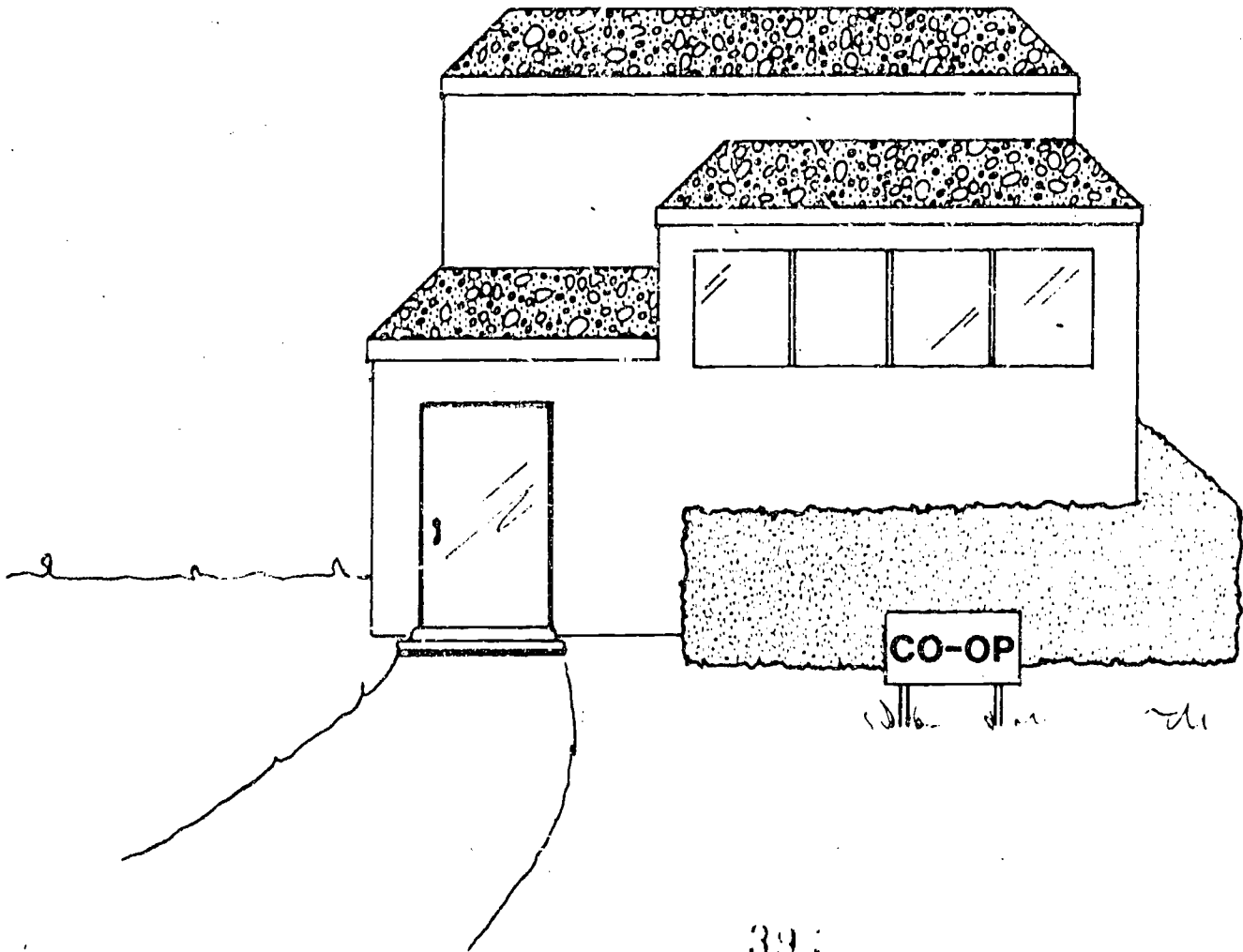

# TWO BASIC TYPES OF COOPERATION

## A. INFORMAL AND UNSTRUCTURED

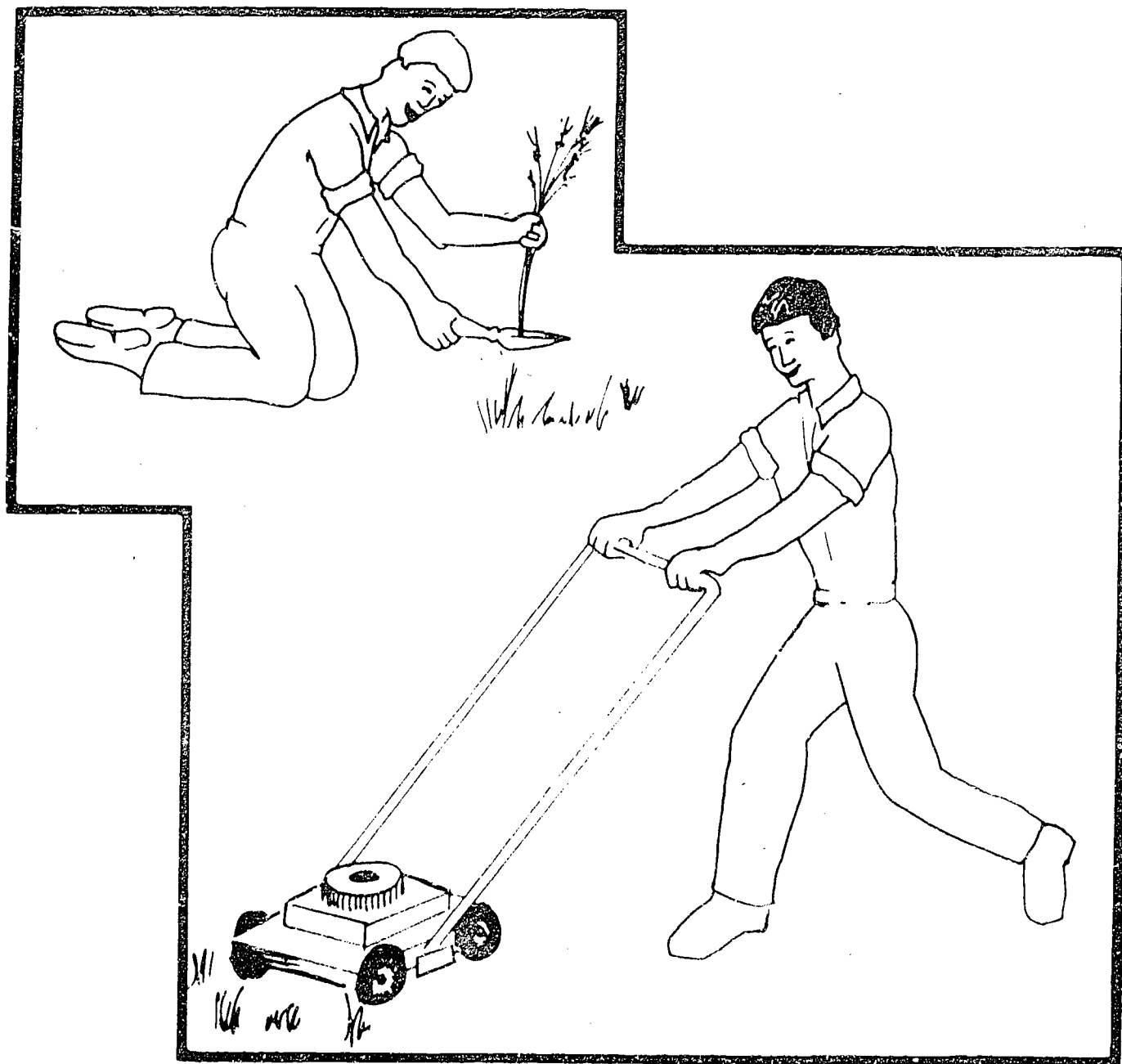

# TWO BASIC TYPES OF COOPERATION

## B. FORMALLY ORGANIZED

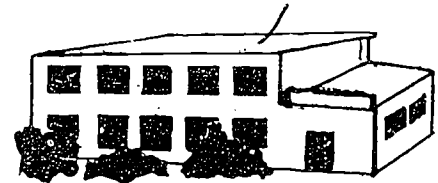
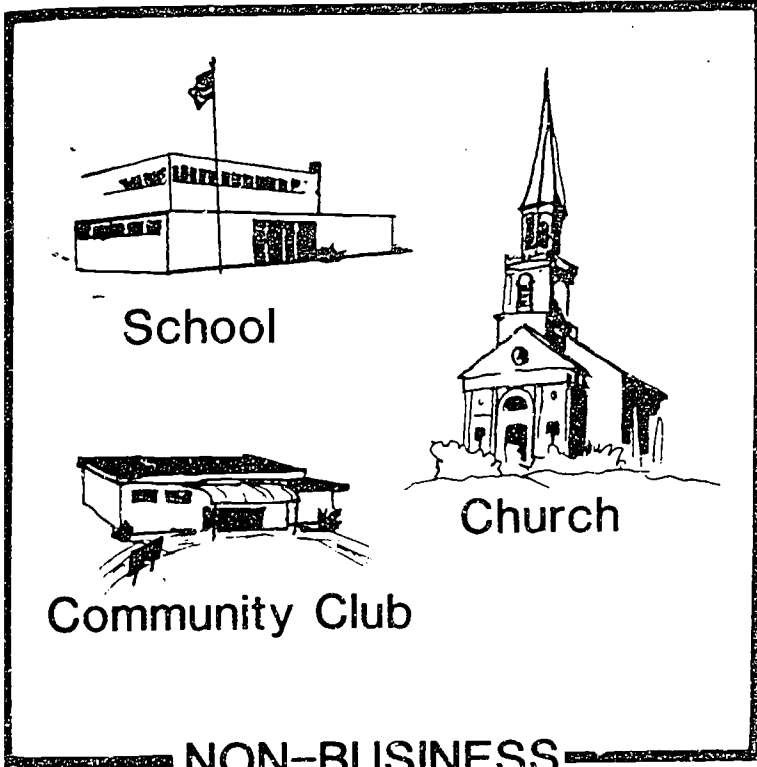

Credit Union

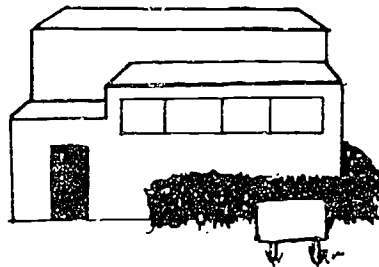

CO-OP

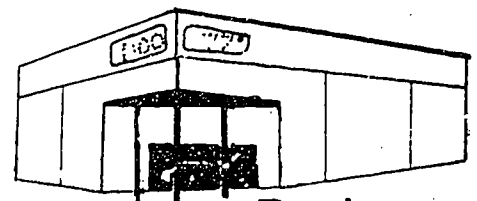

Bank

BUSINESS



# WHAT DOES A COOPERATIVE DO ?

PROVIDES ITS USER-OWNERS  
GOODS AND SERVICES AT COST

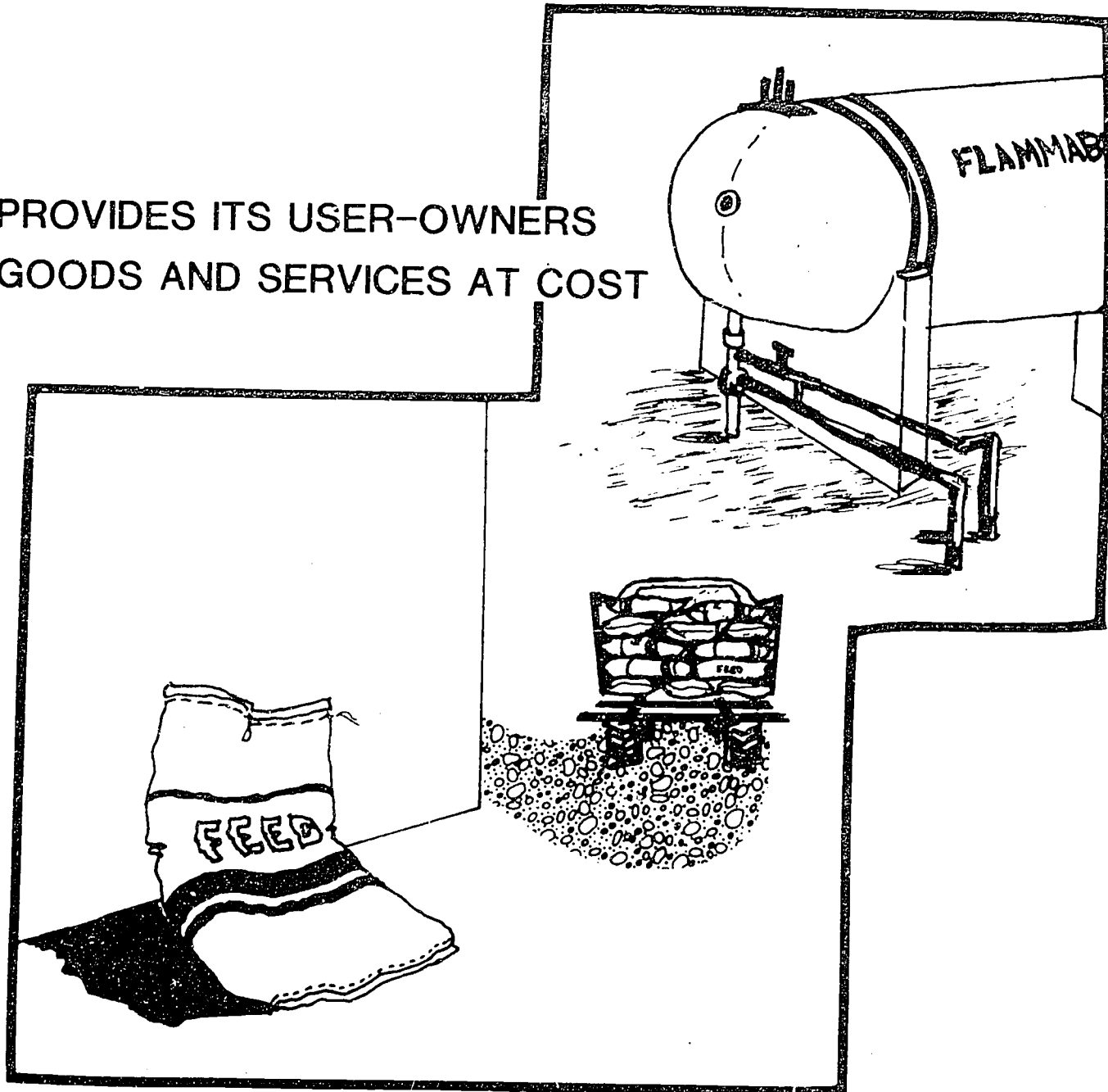

# WHAT TYPES OF COOPERATIVES ARE OPERATING?

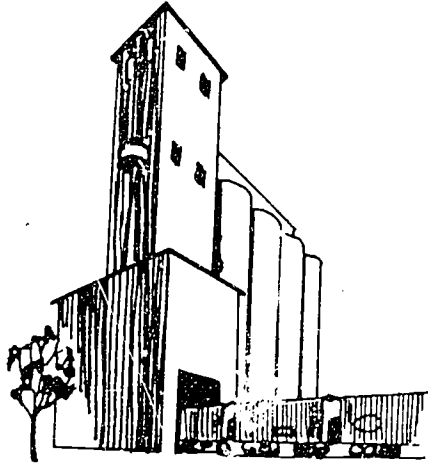

**PURCHASING**

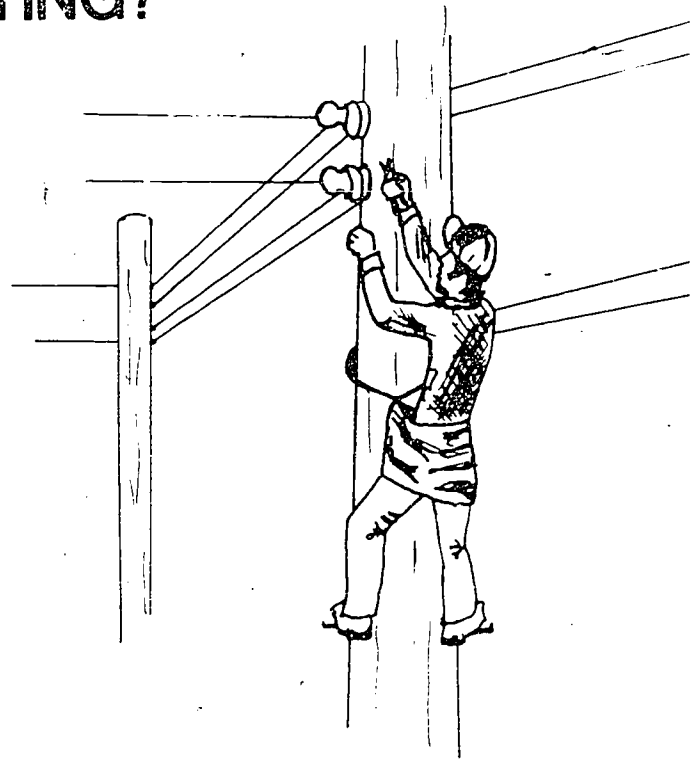

**SERVICE**

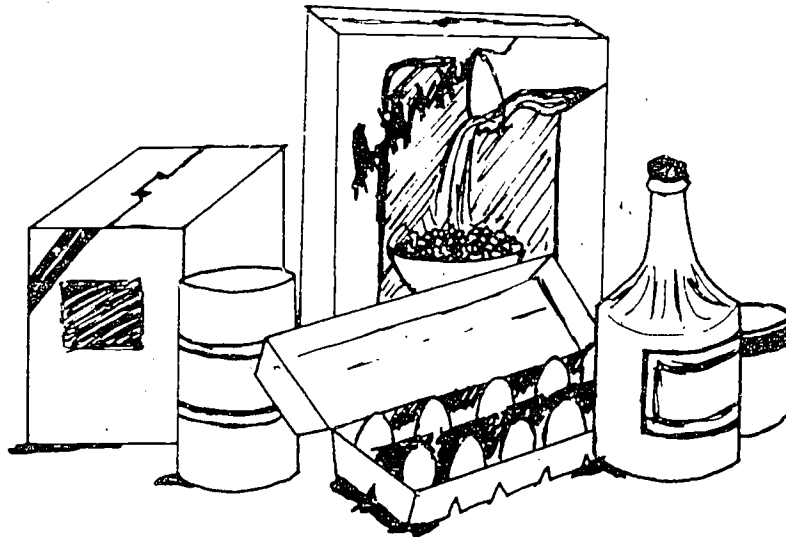

**MARKETING**

---

# HOW IS A COOPERATIVE DISTINCTIVE?

- A. DEMOCRATICALLY CONTROLLED
- B. SERVICE AT COST
- C. LIMITED RETURN ON INVESTMENT
- D. MEMBER OWNED AND FINANCED
- E. OPERATIONS ARE LIMITED

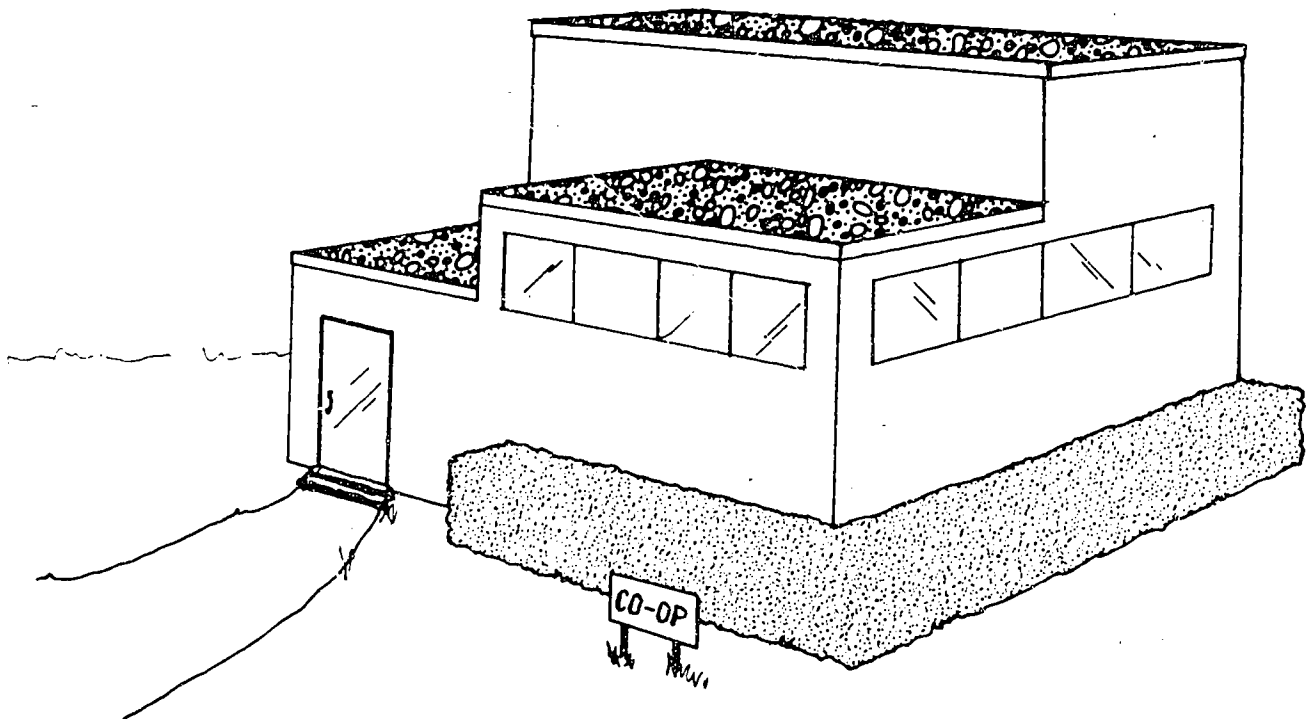

# SAMPLE ORGANIZATION CHART CORPORATION BUSINESS

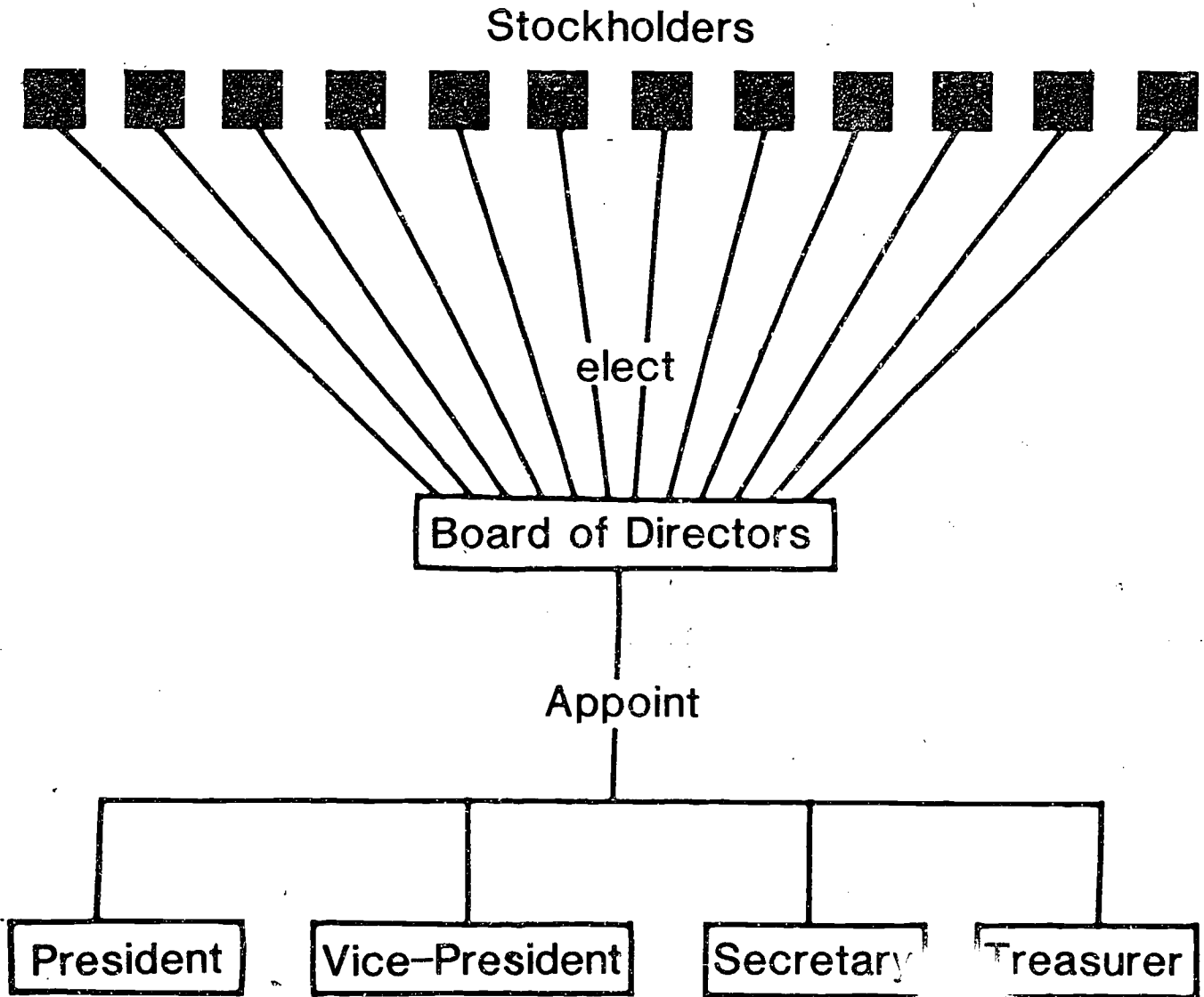

40J

III-I-1-20

TEACHER'S KEY

SAMPLE TEST QUESTIONS

FOUR WAYS OF DOING BUSINESS

1. Match the basic forms of business ownership with the definition on the right.

- |                                  |   |
|----------------------------------|---|
| <u>C</u> 1. Sole Proprietorship  | A. Business owned by two or more persons                                |
| <u>A</u> 2. Partnership          | B. Business authorized by law for benefit of stockholders               |
| <u>B</u> 3. Ordinary Corporation | C. Business owned and managed by one person                             |
| <u>D</u> 4. Co-op Corporation    | D. Business authorized by law for benefit of participating stockholders |

2. Distinguish between advantages (A) and disadvantages (D) of sole proprietorship by placing the correct letter in the blanks.

- |  |   |
|--|---|
| 1. <u>D</u> Difficult to raise capital     | 6. <u>A</u> Few government regulations                |
| 2. <u>A</u> Low taxes                      | 7. <u>D</u> Lack of assistance in business operations |
| 3. <u>D</u> Unlimited liability            | 8. <u>A</u> Freedom of action                         |
| 4. <u>A</u> Personal pride of ownership    | 9. <u>D</u> No sharing of profits                     |
| 5. <u>A</u> Easy to organize and terminate |   |

3. Distinguish between advantages (A) and disadvantages (D) of a partnership by placing the correct letter in the blank provided.

- A 1. Operating economics
- D 2. Sharing profits
- A 3. Increased sources of capital
- D 4. Unlimited liability
- D 5. Risk of liquidation
- D 6. Possibilities of disagreement
- A 7. Division of responsibilities

4. Distinguish between advantages (A) and disadvantages (D) of a corporation by placing the correct letter in the blank provided.
- A 1. Only designated officers can make contracts
  - D 2. Sharing of profits
  - A 3. Ownership easily transferred
  - A 4. Limited liability
  - D 5. No freedom of action
  - D 6. Complicated and costly to organize
  - A 7. Variety of skills, abilities and ideas
5. Distinguish between correct (C) and incorrect (I) statements concerning how a corporation is organized and operated. Place the correct letter in the blanks provided.
- C 1. Ownership is divided into parts of capital stock called shares.
  - 2. Officers in small corporations generally consist of president; vice-president and public relations officer.
  - I 3. Stockholders manage the business directly.
  - I 4. Officers may not employ additional persons to operate the business without expressed consent of the board of directors.
  - C 5. Stockholders own the business.
6. A basic cooperative principle is 1.
- 1. voting rights are limited;--usually one member, one vote.
  - 2. business shall be done for cash and credit.
  - 3. political and religious neutrality is not observed.
  - 4. volume of business of each member shall be limited.
7. The three most generally accepted cooperative "principles" are 3.
- 1. open membership, political and religious neutrality, and cash trading.
  - 2. democratic control, open membership, and limited returns to capital.
  - 3. limited membership, democratic control, and patronage refunds.

8. An example of a purchasing cooperative is a 4.
- |                       |  |
|-----------------------|--|
| 1. creamery.          | 3. dairy herd improvement association. |
| 2. insurance company. | 4. farm supply company.                |
9. In a cooperative, the benefits normally go to 1.
- |                                      |   |
|--------------------------------------|---|
| 1. patrons in proportion to use.     | 3. stockholders according to investment.  |
| 2. one vote for each share of stock. | 4. employees according to work performed. |
10. The right to incorporate is legally granted by 3.
- |                       |                             |
|-----------------------|-----------------------------|
| 1. Federal government | 3. State government         |
| 2. County government  | 4. Federal Trade Commission |
11. Voting rights in a corporation type business are granted to 3.
- |   |
|---|
| 1. One vote per shareholder                       |
| 2. One vote for each member of Board of Directors |
| 3. One vote per share of stock owned.             |
| 4. Patrons who do business with the corporation.  |
12. In a cooperative, control of the organization is vested in its members usually by 1.
- |                                      |                                       |
|--------------------------------------|---------------------------------------|
| 1. each member having one vote.      | 3. voting in proportion to patronage. |
| 2. one vote for each share of stock. | 4. voting in proportion to farm size. |
13. The largest number of businesses in the American private enterprise system are 1.
- |                            |                            |
|----------------------------|----------------------------|
| 1. individual businesses.  | 3. cooperative businesses. |
| 2. partnership businesses. | 4. corporation businesses. |
14. Incorporating a farm enables the business to 2.
- |                        |                         |
|------------------------|-------------------------|
| 1. sell cooperatively. | 3. improve production.  |
| 2. be more permanent.  | 4. reduce income taxes. |
15. In a partnership business 3.
- |  |
|--|
| 1. the number of partners is usually limited by law.                     |
| 2. the primary purpose is to provide more employment opportunities.      |
| 3. the partners share in the economic risks and in the economic rewards. |

16. In a business which is owned by one individual (single proprietorship) 3.

1. the primary purpose is to be of service to the public or the community.
2. the primary purpose is to provide employment for deserving persons.
3. the individual bears the business risks and reaps the profits (or losses).

40.



## UNIT I: AGRICULTURAL BUSINESS MANAGEMENT

### PROBLEM AREA: MARKETING AGRICULTURAL CROPS

#### SUGGESTIONS TO THE TEACHER:

This problem area is designed for use with eleventh grade or advanced students in vocational agriculture programs. The recommended time for teaching this problem area is during the winter months or following the harvesting season.

The estimated instructional time for this problem area is 3 to 7 days depending on the instructional objectives and the degree to which students are to develop their skills in marketing. If the students are to be involved in other marketing exercises, the instructional time will need to be increased.

The instructor is encouraged to conduct a local search to locate other supplementary materials for use with this problem area. The items in this problem area are for reference or modification as instructors adapt these materials to their local situation.

#### CREDIT SOURCES:

These materials were developed through a funding agreement, R-33-13-D-0362-466, with the Illinois State Board of Education, Department of Adult, Vocational and Technical Education, Research and Development Section, 100 North First Street, Springfield, Illinois 62777. Opinions expressed in these materials do not reflect, nor should they be construed as policy or opinion of the State Board of Education or its staff.

The teacher's guide and student worksheets were developed by Jerry Pepple, Department of Vocational and Technical Education, University of Illinois. Transparency masters were developed by L. F. Stice, Department of Agricultural Economics, and by Vocational Agriculture Service, University of Illinois. Part I of the sample test questions were adapted from a test included in a Vocational Agriculture Source Unit on Grain Marketing, University of Illinois. Suggestions and guidance in the development of these materials were provided by the Rural Core Curriculum Field Test Teachers. This problem area was reviewed by the following vocational agriculture teachers:

Garry Raymond--Hampshire High School  
David Erickson--ROVA High School  
Vince Mitchell--Mt. Vernon High School  
Larry Keyser--Clay City High School

## TEACHER'S GUIDE

- I. Unit: Agricultural business management
- II. Problem area: Marketing agricultural crops
- III. Objectives: At the close of this problem area, the student will be able to:
  1. Define common terms used in the grain marketing industry.
  2. Explain the methods of grain marketing used by farmers in the local area.
  3. Understand how export markets affect domestic grain prices.
  4. Explain the procedures used at the local grain terminals to determine grain standards, grading, and discounts of corn, soybeans, and wheat.
  5. Understand how futures markets work and how to use them.
  6. Demonstrate the process of marketing grain through the futures markets.
- IV. Suggested interest approaches:
  1. Obtain multiple copies of a recent edition of the local newspaper containing commodity market prices. Divide the class into small groups and have them locate and report various cash and futures prices. Ask them to identify various reasons for the differences in prices.
  2. Tape record a radio or TV market report and play it for the class. Promote class discussion and interest by asking them why the report includes certain items and what does this information mean to the local farmer and elevator operator.
  3. Promote class discussion on marketing grain by giving each student a selected quantity to market or use the grain from the school land laboratory for marketing. Ask the following lead questions?
    - a. Should we sell or store the grain?
    - b. Where should we sell it?
    - c. What information do we need to have before we can market our grain?
    - d. Where can we get this needed information?
- V. Anticipated problems and concerns of students:
  1. What are the local problems farmers have most often when marketing their grain?

2. Are the local grain handling facilities adequate so they can serve farmers efficiently?
3. How many local farmers make use of the futures market?
4. Can people other than farmers buy and sell on the futures market?
5. Why do we need an understanding of futures marketing?
6. How does the export market affect our local prices?
7. What are the local marketing channels from producer to consumer?
8. What are the major markets for Illinois grain?
9. How does a local elevator set the prices it quotes?
10. How does the local elevator determine the grade of grain?
11. How can producers reduce grain discounts?
12. What led to the development of futures markets?
13. How do you buy and sell futures?
14. What are the common terms used in marketing grain and what do they mean?
15. How does hedging differ from speculation?
16. How can we "fix" the price of a crop?
17. What are some approved practices to follow when using the futures markets?

VI. Suggested learning activities and experiences:

1. Develop and conduct an interest approach to initiate student concern about different grain marketing techniques.
2. Identify student objectives for this problem area.
3. List the problems and concerns which need to be solved to accomplish the objectives.
4. Have students develop a short survey form to identify local marketing techniques and problems within the local community. Have students report and summarize their results in class after they have conducted a community survey.
5. Distribute and examine the different types of marketing information available to producers to help them make their marketing decisions. Use the "Market Information Sheet" included with this problem area to identify possible sources of information.

6. Have students develop a bulletin board showing grain price trends over a period of days and weeks. Let them obtain and record the daily market prices. Discuss the reasons why the prices move up or down.
7. Distribute Worksheet 1, "Marketing Terms and Definitions." Divide the class into buzz groups and have them complete the worksheet. Give the group with the most correct answers a reward of some type. Explain any terms the class could not locate or identify.
8. Plan and conduct a field trip to a local elevator and have students complete Worksheet 2, "How a Local Elevator Operates." Discuss the findings of the field trip during the following class period.
9. Assign students a quantity of grain to market and have them sell their grain independently to determine which class members have the highest average price. Use Job Sheet on Hedging Soybeans as an alternative exercise.
10. Develop class discussion on how to calculate the cost of producing and storing corn. Ask students how they can determine if a certain price is above the cost of production of a crop.
11. Identify the students' problems and concerns relating to establishing a break-even price. Distribute VAS Unit 2044, "Calculating the Cost of Producing and Storing Corn," and conduct supervised study to let students answer the selected problems and concerns.
12. Demonstrate how to calculate a break-even price by using the sample worksheets included in VAS Unit 2044, Part 3.
13. Identify student problems and concerns relating to futures markets and hedging. Obtain materials from Chicago Board of Trade which relate to hedging and futures (See Section IX for address) and have students read through the information to locate answers to their questions. Use transparencies included with this problem area for additional information.
14. Organize a field trip to the Chicago Board of Trade so students can observe the actual trading of commodities.
15. Obtain copies of the Hedging Worksheets and Problems from Vocational Agriculture Service and assign selected exercises for students to solve.
16. Have students work through the VAS Microcomputer Program #16, Grain Marketing, Student Worksheet 3.
17. Have students develop a marketing strategy for selling their crops.

VII. Application procedures:

1. Discuss with the class how the various marketing techniques can be used to benefit their S.O.E. program and home farm.
2. Identify possible career opportunities associated with the grain marketing industry.

VIII. Evaluation:

1. Administer a pencil and paper test to measure the students' understanding of various marketing techniques.
2. Collect and grade student worksheets.
3. Evaluate students' participation on class field trips and during other group activities.

IX. References and aids:

1. VAS Unit 2044, Calculating the Cost of Producing and Storing Corn
2. VAS Worksheets on Hedging with Teacher's Key and Problems
3. VAS Microcomputer Program #16, Grain Marketing
4. Introduction to Hedging and Workbook, and other materials for high school students on grain marketing are available from:

Literature Services  
Chicago Board of Trade  
La Salle at Jackson  
Chicago, Illinois 60604  
Ph. # 312/435-3558

400

COMPETENCY INVENTORY  
MARKETING AGRICULTURAL CROPS

1. Student has no knowledge of competency.
2. Student has read about competency.
3. Student has seen competency performed.
4. Student has performed competency.
5. Student has performed competency without supervision.
6. Student does possess skill.
7. Student does not possess skill.

Competency	Circle One						
1. Describe the different methods of grain marketing.	1	2	3	4	5		
2. Explain grain marketing trends, factors influencing the trends, and how the trends affect farm business management decisions.	1	2	3	4	5		
3. Describe the factors that affect grain prices.	1	2	3	4	5		
4. Explain government influence on grain marketing.	1	2	3	4	5		
5. Identify the transportation problems involved with grain marketing.	1	2	3	4	5		
6. Describe the effects of exports and imports on local grain market prices.	1	2	3	4	5		
7. Analyze and compare cooperative, private, and corporate grain marketing operations.	1	2	3	4	5		
8. Explain the effects of grain storage on marketing.	1	2	3	4	5		
9. Interpret marketing news and marketing information on grain marketing.						6	7
10. Analyze the influence and importance of competition in U.S. grain marketing.						6	7

These competencies are outlined in the National Ag Occupations Competency Study, 1978, for entry level positions in agriculture.

Name \_\_\_\_\_ Date \_\_\_\_\_

## MARKET INFORMATION SHEET

<u>PUBLICATION</u>	<u>SOURCE</u>	<u>FREQUENCY OF PUBLICATION</u>
Illinois Farmers Outlook Letter	Cooperative Extension Service University of Illinois 123 Mumford Hall 1301 West Gregory Urbana, Illinois 61801	Weekly
Grain Market News	U.S. Department of Agriculture Consumer & Marketing Service Grain Division Ill. Dept. of Agriculture Agriculture Bldg., Fairground Springfield, Ill. 62706	Weekly
Illinois Crop Report	Illinois Dept. of Agriculture Division of Agricultural Statistics P.O. Box 429 Springfield, Ill. 62705	Weekly, monthly, quarterly, annual
Illinois Weekly Weather and Crop Bulletin	Illinois Dept. of Agriculture Division of Agricultural Statistics P.O. Box 429 Springfield, Ill. 62705	Weekly
Illinois Farm Bulletin	Illinois Dept. of Agriculture Division of Agricultural Statistics P.O. Box 429 Springfield, Ill. 62705	Semi-monthly
Grain Market News	U.S. Department of Agriculture Grain Division, Consumer and Marketing Service Independence, Mo. 64050	Weekly
Crop Production	U.S. Department of Agriculture Statistical Reporting Service Crop Reporting Board Washington, D.C. 20250	Monthly
Feed Situation Fats and Oils Situation Livestock and Meat Situation	U.S. Department of Agriculture Economic Research Service Economic and Statistical Analysis Division Washington, D.C. 20250	Quarterly
Foreign Agriculture	U.S. Department of Agriculture Foreign Agricultural Service Washington, D.C. 20250	Weekly

Commitments of Traders in  
Commodity Futures

U.S. Department of Agriculture    Monthly  
Commodity Exchange Authority  
141 West Jackson Blvd., Room 1200  
Chicago, Ill. 60604

The Commodity Future  
Trading Guide

Jewels, Harlow, Stone  
McGraw Hill

Book

---

Made available by L. F. Stice, Department of Agricultural Economics, University  
of Illinois

412

III-I-2-10



# STUDENT WORKSHEET 1

## MARKETING TERMS AND DEFINITIONS\*

Match the term in Column A with the definition in Column B

<u>Column A</u>	<u>Column B</u>
___ 1. Basis	A. In trading, the definite price stated by a customer to a broker restricting the execution of an order to buy for not more than or to sell for not less than the stated price.
___ 2. Bear Market	B. Where large supplies and/or poor demand cause a decline in price.
___ 3. Bid	C. Goods that can be bought and/or sold.
___ 4. Broker	D. The amount deposited by buyers and sellers of futures, to insure performance on contracts commitments; serves as a performance bond rather than a "down-payment."
___ 5. Bull Market	E. One who attempts to anticipate price changes and through market activities makes profits, and who is not trading.
___ 6. Buyer	F. The price at which a physical commodity is selling at a given time and place.
___ 7. Close	G. The price fixed by the Clearing House at which deliveries on futures are invoiced and also the price at which the futures contract is settled when deliveries are made.
___ 8. Commodity	H. Is the sale of futures when holding the physical commodity or its equivalent, as protection against a price decline; or the purchase of futures against forward sales or anticipated requirements of the physical commodity, as protection against a price advance.
___ 9. Cover	I. The spread or difference between the spot or "cash" price and the price of a specified futures delivery month price, or may also be used to designate price differentials between "cash" and more distant futures delivery months, as well as different locations as specified.
___ 10. Delivery Month	
___ 11. Delivery Notice	
___ 12. Delivery Points	
___ 13. Delivery Price	
___ 14. First Notice Day	
___ 15. Futures Contract	
___ 16. Hedging	
___ 17. Limit (up or down)	
___ 18. Limit Only	
___ 19. Long	
___ 20. Margin	
___ 21. Margin Call	
___ 22. Marketing	
___ 23. Marketing Channel	

- |  |   |
|--|---|
| <p>_____ 24. Marketing Margin</p> <p>_____ 25. Open Contracts</p> <p>_____ 26. Point</p> <p>_____ 27. Speculator</p> <p>_____ 28. Spot Price</p> | <p>J. The minimum price fluctuation in futures. It is equal to 1/100 of one cent in most futures traded in decimal units. In grains, it is 1/8 of one cent.</p> <p>K. The route that a commodity takes on its way from the producer to the ultimate consumer.</p> <p>L. Where small supplies and/or strong demand causes prices to rise.</p> <p>M. One who has bought grain: also one who is on the buying side of an open (unhedged) futures contract.</p> <p>N. The period at the end of the futures trading session during which all trades are officially declared as having been executed "at or on the close." The closing range is the range of prices on trades made during this designated period.</p> <p>O. A price offered subject, unless otherwise stated, to immediate acceptance for a specific amount of commodity.</p> <p>P. All of the processes and services involved in moving a commodity from the producer to the ultimate consumer. The activity involved in buying or selling product.</p> <p>Q. The notification of delivery of the actual commodity on the contract, issued by the seller of the futures to the Clearing House.</p> <p>R. A purchaser of a commodity offered for sale or exchange.</p> <p>S. An agent entrusted with the execution of an order. This person may be employed in the office of the commission house that carries the account or a floor broker or pit broker who actually executes the order on the trading floor.</p> <p>T. The maximum price advance or decline from the previous day's settlement price permitted in one trading session by the rules of the exchange.</p> |
|--|---|

- U. The first day on which notices of intentions to deliver actual commodities against futures market positions can be made or received. First notice day will vary with each commodity and exchange. It usually precedes the beginning of the delivery period.
- V. Those locations designated by commodity exchanges at which a commodity covered by a futures contract may be delivered in fulfillment of the contract.
- W. The purchase of futures to offset a previously established short position.
- X. The calendar month during which a futures contract matures.
- Y. The difference between the amount consumers pay for the final product and the amount producers receive.
- Z. A request to deposit either the original margin at the time of the transaction, or to restore the guarantee to "maintenance margin" levels required for the duration of the time the contract is held.
- AA. An agreement to buy and receive or to sell and deliver a commodity at a future date with certain specified characteristics.
- BB. Contracts which have been bought or sold without the transaction having been completed by subsequent sale or repurchase, or actual delivery or receipt of commodity.

\*Selected from National FFA Contests, Bulletin No. 4, 1982/1983/1984, pages 26-32, Kansas City, Missouri.

STUDENT WORKSHEET 2  
HOW A LOCAL ELEVATOR OPERATES

- I. Student's Name \_\_\_\_\_ Date \_\_\_\_\_
- II. Name of elevator \_\_\_\_\_
- III. Manager's Name \_\_\_\_\_
- IV. Date elevator opened for business \_\_\_\_\_
- V. Number of current employees \_\_\_\_\_
- VI. Type of business (private, coop, etc.) \_\_\_\_\_
- VII. Major services provided by elevator \_\_\_\_\_  
\_\_\_\_\_  
\_\_\_\_\_
- VIII. Volume (bu.) of grain sales (average) \_\_\_\_\_
- IX. Where and how do you ship your grain? \_\_\_\_\_  
\_\_\_\_\_
- X. What is the capacity for storage? \_\_\_\_\_  
\_\_\_\_\_
- XI. What marketing services are offered through the elevator? \_\_\_\_\_  
\_\_\_\_\_
- XII. What prices are you quoting on today's cash markets for corn, soybeans and wheat? \_\_\_\_\_  
\_\_\_\_\_
- XIII. What is done with the gain as it is brought in for sale or storage? \_\_\_\_\_  
\_\_\_\_\_  
\_\_\_\_\_
- XIV. What career opportunities are available in the local grain marketing industry? \_\_\_\_\_  
\_\_\_\_\_  
\_\_\_\_\_
- XV. What qualifications does an individual need to be employed at an elevator? \_\_\_\_\_  
\_\_\_\_\_  
\_\_\_\_\_

## STUDENT WORKSHEET 3

### GRAIN MARKETING

Program #16 - Microcomputer Project

Vocational Agriculture Service  
University of Illinois  
1401 S. Maryland Drive  
Urbana, IL 61801

#### I. Objectives

This program is designed to allow the user to compare the cost of producing and holding a crop to potential marketing opportunities.

#### II. References

A. Author: Andrew A. Anderson  
AAA Ag Services  
R.R. 1 Box 88A  
Leland, IL 60531

B. Others: Farm Management Manual, by R.A. Hinton, University of Illinois at Urbana (available from Vocational Agriculture Service)  
Weekly Outlook Letter, Department of Agricultural Economics, University of Illinois at Urbana

#### III. Scope of Program

The program carries through the calculations for a crop being stored for each month up to a 12-month period.

#### IV. Procedure

A. Inputs: You will need to obtain figures for the following:

- |                             |   |
|-----------------------------|---|
| 1. Interest rate            | 7. Land costs                                 |
| 2. Storage costs            | 8. Labor costs                                |
| 3. Number of months to view | 9. Supply costs (fertilizer, herbicide, etc.) |
| 4. Market values per month  | 10. Equipment costs                           |
| 5. Number of bushels        | 11. Drying costs                              |
| 6. Acres of crop            | 12. Hauling costs                             |

B. Outputs: The following are the results of the program:

1. Market value
2. Storage to date
3. Production cost
4. Interest to date
5. Invested total
6. Net profit/bu.

(Above figures are for each month of marketing being considered.)

V. Other Suggestions

Interest and storage costs should be expressed as decimals. It is helpful to have monthly price projections made ahead of time.

413

## STUDENT JOB SHEET

### MARKETING SOYBEANS BY HEDGING

- I. Situation: You are employed as a farm manager at a local banking institution. You have to market 10,000 bushels of soybeans. You have calculated a break-even price of \$6.30 per bushel. Complete the following T-account using current cash and future prices.

CASH	FUTURES	BASIS
current price for new crop soybeans \$ _____	(buy) (sell) two December soybean contracts \$ _____	(over) \$ _____ (under)December
harvest price for new crop soybeans \$ _____	(buy) (sell) two December soybean contracts \$ _____	(over) \$ _____ (under)December
outcome (+) (-) \$ _____	outcome (+) (-) \$ _____	change \$ _____
CASH SALE PRICE \$ _____ per bushel		
FUTURES (GAIN)(LOSS) \$ _____ per bushel		
FINAL SALE PRICE \$ _____ per bu.		

II. Questions:

1. Did you make or lose money on your hedging? \_\_\_\_\_ Why? \_\_\_\_\_  
 \_\_\_\_\_  
 \_\_\_\_\_
2. What factors influenced the market to move with you or against you?  
 \_\_\_\_\_  
 \_\_\_\_\_  
 \_\_\_\_\_
3. What sources of information did you utilize for marketing information?  
 \_\_\_\_\_  
 \_\_\_\_\_  
 \_\_\_\_\_

- III. Conclusions: What approved practices were developed which can be used to increase your S.O.E. profits?

TEACHER'S KEY  
STUDENT WORKSHEET 1

MARKETING TERMS AND DEFINITIONS\*

Match the term in Column A with the definition in Column B

<u>Column A</u>	<u>Column B</u>
<u>I</u> 1. Basis	A. In trading, the definite price stated by a customer to a broker restricting the execution of an order to buy for not more than or to sell for not less than the stated price.
<u>B</u> 2. Bear Market	B. Where large supplies and/or poor demand cause a decline in price.
<u>O</u> 3. Bid	C. Goods that can be bought and/or sold.
<u>S</u> 4. Broker	D. The amount deposited by buyers and sellers of futures, to insure performance on contracts commitments; serves as a performance bond rather than a "down-payment."
<u>L</u> 5. Bull Market	E. One who attempts to anticipate price changes and through market activities makes profits, and who is not hedging.
<u>R</u> 6. Buyer	F. The price at which a physical commodity is selling at a given time and place.
<u>N</u> 7. Close	G. The price fixed by the Clearing House at which deliveries on futures are invoiced and also the price at which the futures contract is settled when deliveries are made.
<u>C</u> 8. Commodity	H. Is the sale of futures when holding the physical commodity or its equivalent, as protection against a price decline; or the purchase of futures against forward sales or anticipated requirements of the physical commodity, as protection against a price advance.
<u>W</u> 9. Cover	I. The spread or difference between the spot or "cash" price and the price of a specified futures delivery month price, or may also be used to designate price differentials between "cash" and more distant futures delivery months, as well as different locations as specified.
<u>X</u> 10. Delivery Month	
<u>Q</u> 11. Delivery Notice	
<u>V</u> 12. Delivery Points	
<u>G</u> 13. Delivery Price	
<u>U</u> 14. First Notice Day	
<u>AA</u> 15. Futures Contract	
<u>H</u> 16. Hedging	
<u>T</u> 17. Limit (up or down)	
<u>A</u> 18. Limit Only	
<u>M</u> 19. Long	
<u>D</u> 20. Margin	
<u>Z</u> 21. Margin Call	
<u>P</u> 22. Marketing	
<u>K</u> 23. Marketing Channel	



- Y 24. Marketing Margin
- BB 25. Open Contracts
- J 26. Point
- E 27. Speculator
- F 28. Spot Price

- J. The minimum price fluctuation in futures. It is equal to 1/100 of one cent in most futures traded in decimal units. In grains, it is 1/8 of one cent.
- K. The route that a commodity takes on its way from the producer to the ultimate consumer.
- L. Where small supplies and/or strong demand causes prices to rise.
- M. One who has bought grain: also one who is on the buying side of an open (unhedged) futures contract.
- N. The period at the end of the futures trading session during which all trades are officially declared as having been executed "at or on the close." The closing range is the range of prices on trades made during this designated period.
- O. A price offered subject, unless otherwise stated, to immediate acceptance for a specific amount of commodity.
- P. All of the processes and services involved in moving a commodity from the producer to the ultimate consumer. The activity involved in buying or selling product.
- Q. The notification of delivery of the actual commodity on the contract, issued by the seller of the futures to the Clearing House.
- R. A purchaser of a commodity offered for sale or exchange.
- S. An agent entrusted with the execution of an order. This person may be employed in the office of the commission house that carries the account or a floor broker or pit broker who actually executes the order on the trading floor.
- T. The maximum price advance or decline from the previous day's settlement price permitted in one trading session by the rules of the exchange.

- U. The first day on which notices of intentions to deliver actual commodities against futures market positions can be made or received. First notice day will vary with each commodity and exchange. It usually precedes the beginning of the delivery period.
- V. Those locations designated by commodity exchanges at which a commodity covered by a futures contract may be delivered in fulfillment of the contract.
- W. The purchase of futures to offset a previously established short position.
- X. The calendar month during which a futures contract matures.
- Y. The difference between the amount consumers pay for the final product and the amount producers receive.
- Z. A request to deposit either the original margin at the time of the transaction, or to restore the guarantee to "maintenance margin" levels required for the duration of the time the contract is held.
- AA. An agreement to buy and receive or to sell and deliver a commodity at a future date with certain specified characteristics.
- BB. Contracts which have been bought or sold without the transaction having been completed by subsequent sale or repurchase, or actual delivery or receipt of commodity.

\*Selected from National FFA Contests, Bulletin No. 4, 1982/1983/1984, pages 26-32, Kansas City, Missouri.

---

# FARMERS CAN USE FUTURES MARKETS

- To price growing crops
- To price stored grains
- To price feed grains
- To speculate on price changes
- To gain market information
- To plan marketing programs

From materials developed by L. F. Stice, Department of Agricultural Economics.

---

# FUTURES CONTRACT

● a firm commitment to deliver or to receive specified quantities and grades of a commodity during a designated month with price being determined by public auction in the pit.

From materials developed by L. F. Stice, Department of Agricultural Economics.

---

# ESSENTIALS OF A FUTURES CONTRACT

- A firm commitment
- Agreement to deliver or to receive
- A specific quantity
- Specific grades
- Delivery month is designated
- Price determined by public auction in the pit

From materials developed by L. F. Stice, Department of Agricultural Economics.

---

# CASH MARKET

## FUNCTIONS PERFORMED

- Price is determined
- Ownership changes
- Physical transfer is made

From materials developed by L. F. Stice, Department of Agricultural Economics.

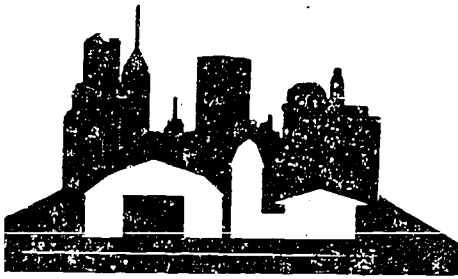

# BOARD OF TRADE OF THE CITY OF CHICAGO

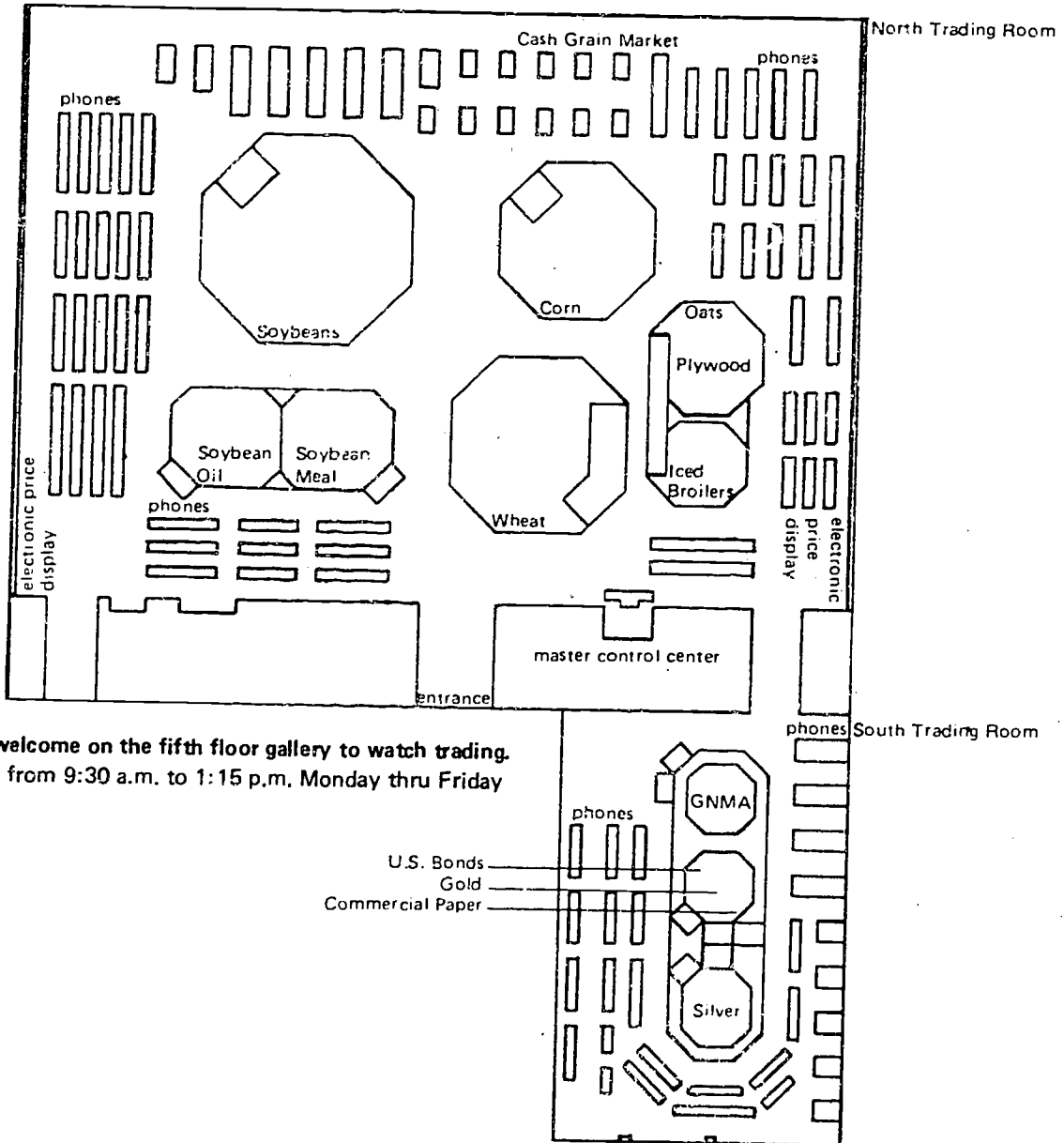

Visitors are welcome on the fifth floor gallery to watch trading.  
Sessions run from 9:30 a.m. to 1:15 p.m. Monday thru Friday

U.S. Bonds  
Gold  
Commercial Paper

From materials developed by L. F. Stice, Department of Agricultural Economics.

III-1-2-27

---

# HOW TRADING IS DONE

- In pits
- Hand signals
- Bids & offers cried out
- Prices reported
- Trades reported to Clearing House

From materials developed by L. F. Stice, Department of Agricultural Economics.

425

III-1-2-28



---

# **FUTURES MARKET JOBS PERFORMED**

- **Price discovered**
- **Risk shifted**
- **Market information**
- **Regulated trading**

From materials developed by L. F. Stice, Department of Agricultural Economics.

III-1-2-29

---

# THE BASIS: CASH-FUTURES RELATIONSHIP

The Basis — Spread between price of cash grain at a specific location and price of futures contract.

Cash Grains — Are priced in relation to, or "basis" the price of the nearby futures contract.

The Basis to a distant futures contract includes:

- A. The basis to the nearby future.
- B. The spread or "carrying charge" between the nearby and the distant contracts.

From materials developed by L. F. Stice, Department of Agricultural Economics.

---

# CASH AND FUTURES CONTRASTED

## FUTURES CONTRACT

1. To speculate or hedge against commodity changes.
2. Executed in the pit.
3. Trade in round lots.
4. Future month used for delivery.
5. Sellers option of day of delivery.
6. Sellers option of grade to be delivered (within specified limits).

## CASH CONTRACT

1. To market or merchandise the commodity, or to speculate.
2. Executed at exchange tables or privately.
3. Trade in irregular amounts.
4. Varying times for delivery.
5. May or may not have optional period of delivery.
6. Usually calls for specific grade or type of commodity.

From materials developed by L. F. Stice, Department of Agricultural Economics.

III-1-2-31

---

# FACTS ABOUT USE OF FUTURES

The advantages in using futures to price grains are:

- A. Pricing can be done separately from the transfer of ownership.
- B. Therefore, income can be earned from the storing of grains in declining prices.
- C. Growing crops can be priced with futures when there are no cash bids.
- D. The futures pricing transaction can be easily reversed, and therefore is flexible.

But there are risks in using futures to price grains.

When to price grains involves a price forecast — so only a part of it should be priced at one time.

Have a plan for getting out of the market if the market goes against you.

From materials developed by L. F. Stice, Department of Agricultural Economics.

---

# WHAT ARE FUTURES MARKETS?

A system of trading in contracts for the future delivery of actual commodities.

Membership Associations — of people whose business is related to the marketing of commodities.

Democratically Governed by Membership — committees and executive officers.

Functions of a Futures Exchange:

- A. Provide facilities for trading
- B. Write rules
- C. Supervise trading
- D. Distribute marketing information
- E. Act as trade association

Exchanges Regulated by Government:

- A. Commodity Futures Trading Commission
- B. State and Federal Warehouse Laws

From materials developed by L. F. Stice, Department of Agricultural Economics.

III-1-2-33

---

# CARRYING CHARGE

Carrying charge is spread in Futures Contracts

Size of carrying charge is influenced by:

Prevailing storage rates at the market

Supply of and demand for storage space at futures market

Supply of and demand for grain — for use and for inventory

Interest rates on money

Price of grains

Full carrying charge

Inverse carrying charge

From materials developed by L. F. Stice, Department of Agricultural Economics.

---

# FACTORS WHICH AFFECT BASIS

Flow of Grain

Transportation Charges

To other markets

To futures markets

Condition of Grain

Carrying Charges at Futures Markets

Supply of space

Demand for Space

Interest rates

Supply of and Demand for Space at Other Locations

Size of crop

Supply of usable Space

Marketing

From materials developed by L. F. Stice, Department of Agricultural Economics.

III-I-2-35

---

# BASIS PRINCIPLES—SUMMARY

Cash and futures price spreads are usually widest at harvest and converge as the storage season progresses.

The basis at a market point at the close of a storage season is fairly predictable.

The harvest basis is less predictable:

- A. Large crops, heavy harvest marketings, and poor quality grains tend to widen the basis—depress cash in relation to futures.
- B. Small crops, light harvest marketings and high quality storable grains tend to narrow the harvest basis.
- C. Strong market demands for use and/or for inventory tend to narrow the harvest basis and vice versa.

The narrowing of the basis during a storage season is the market's payment for the storage of hedged grains.

From materials developed by L. F. Stice, Department of Agricultural Economics.



## PRICING STORED SOYBEANS

### CASH MKT.

Oct. stored at \$5.90

June sell at \$6.50

### FUTURES MKT.

sell July at \$6.45

buy July at \$6.60

Loss .15



Sale price of soybeans \$6.50

Loss on future .15

Gross price \$6.35

From materials developed by L. F. Stice, Department of Agricultural Economics

---

# PRICING STORED CORN

## Cash mkt.

Oct. store at \$2.04

June sell at \$2.25

## Futures mkt.

sell July at \$2.54

buy July at \$2.40

gain .14



Sale price of corn \$2.25

Gain on future .14

Gross price for corn \$2.39

From materials developed by L. F. Stice, Department of Agricultural Economics.

# SELL CORN --- BUY FUTURE

## CASH MKT.

Oct. sell at \$2.04

June -----

## FUTURES MKT.

buy July at \$2.54

sell July at \$2.65

gain .11

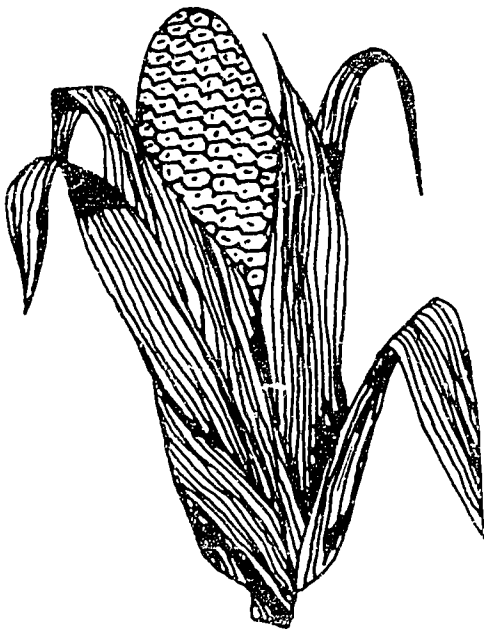

Sale price of corn \$2.04

Gain on future .11

Gross for corn \$2.15

From materials developed by L. F. Stice, Department of Agricultural Economics.

TEACHER'S KEY  
SAMPLE TEST QUESTIONS  
GRAIN MARKETING

I. True or False

- T   1. Futures markets are advanced and sophisticated systems of trading in contracts for future delivery, and a fairly high level of knowledge about them is necessary if they are to be used effectively.
- T   2. Farmers may use futures as a part of their farm business by fixing the price of a crop before harvest.
- T   3. Farmers may use futures as a part of their farm business to fix the price of grain in storage for later delivery.
- T   4. Farmers may use futures as a part of their farm business to fix the cost of feed without taking immediate delivery.
- T   5. Farmers may use futures as a part of their farm business to speculate in the price of a crop that has been produced but for which storage is not available.
- F   6. Farmers may speculate in the futures market in the same manner as a lawyer, doctor, teacher, housewife, or others. This, too, is a part of their farm business.
- T   7. Basis is the difference between cash and futures price.
- F   8. Typically, the cash price does not increase in relation to the futures as the storage season progresses.
- T   9. Narrowing of the basis is equal to the market price for storage.
- T   10. Futures markets are not used extensively for transfer of title.
- F   11. The Chicago Board of Trade is not the largest in the "futures" trading of grain.
- T   12. A futures contract is an agreement between two members of an exchange to buy and sell at a specified time future an agreed amount of a commodity at an agreed price.
- F   13. A futures contract is not a firm and binding contract.
- T   14. A unit of trading for major grains is 5,000 bushels.
- T   15. Units smaller than 5,000 bushels cannot be traded.
- T   16. A change in price of 1/8 of a cent amounts to \$6.25 on a 5,000-bushel contract.

III-1-2-41

- F 17. Trading on the Chicago Board of Trade is done in hexagonal pits.
- T 18. A market reporter is stationed in an elevated position above the pits to observe change of price and place it on the ticker system for transmission throughout the world.
- T 19. Scalpers, pit traders, position traders, and spreaders are speculators attempting to earn money from the change in price.
- T 20. Futures Commission Firms are the means by which non-members, that is, the general public, become principals in futures market trades.
- F 21. The chief function of the exchange (Chicago Board of Trade) is to trade in futures contracts.
- F 22. There are no government regulations directing the exchange.
- T 23. To trade in futures markets, nonmembers must become customers of commission futures merchants.
- F 24. Customers are not required to sign an agreement but are required to make a deposit of funds to guarantee performance on contracts.
- F 25. The commission futures merchant has only a limited number of kinds or types of orders that he/she will take.
- T 26. Orders placed miles from Chicago can be completed with great speed.
- T 27. A position in the Futures market can be either long or short.
- T 28. To be long is to have a contract to purchase, accept delivery, and pay for a commodity later.
- T 29. To be short is to have a contract to sell, deliver, and accept payment for a commodity later.
- T 30. Futures contracts usually serve purposes other than to transfer title.
- T 31. Contracts are offset by making opposite transactions.
- F 32. Futures contracts are not binding, enforceable contracts.
- T 33. Futures commission merchants are liable to the clearing house for the trades of their customers.
- T 34. Initial and maintenance margins are required by the commission merchant to guarantee performance by the customer.

- T 35. Factors affecting futures prices are the same as those affecting price of cash grain.
- T 36. The opening of the Illinois-Michigan Canal linking the Illinois River and Lake Michigan brought about a need for risk shifting.
- T 37. Five functions of futures trading are: (1) publicity and information, (2) regulatory, (3) financing, (4) risk shifting, and (5) pricing.
- T 38. Open interest is the amount of unoffset commitments in futures.
- F 39. The jobs of rationing supply and guiding production are not a function of price.
- T 40. There is one and only one average price that will make supply just clear the market.

Part II. Matching--(match the terms to the correct definition)

<u>Column 1</u>		<u>Column 2</u>
<u>2</u>	A. Goods that can be bought and/or sold.	1. Marketing margin
<u>4</u>	B. Is the sale of futures when holding the commodity or its equivalent as protection against price changes.	2. Commodity
<u>3</u>	C. The difference between the cash price and futures price.	3. Basis
<u>5</u>	D. The route that a commodity takes on its way from the producer to the consumer.	4. Hedging
<u>1</u>	E. The difference between the amount consumers pay for the final product and the amount producers receive.	5. Marketing channel

Part III--Calculate solutions to the following problem on marketing corn.

1. A farmer has estimated an average fixed and variable cost per acre at \$350. The return to management is set at 6% of the total cost of production per acre. The farmer has established a profit level at 8% of the total cost of production per acre. The farmer expects an average yield of 140 bushels of corn per acre. The total production will be about 10,000 bushels of corn.
  - a. Calculate the farmer's expected break-even price per bushel.

Answer:

$$\$350 \times .06 = \$21.00 \text{ per acre for return to management}$$

$$\$350 \times .08 = \$28.00 \text{ per acre for profit}$$

$$\$350.00 + \$21.00 + \$28.00 = \$399.00$$

$$\frac{\$399.00}{140 \text{ bu}} = \$2.85 \text{ break-even price per bushel}$$

- b. Check today's cash market and the futures market prices. Record your finds below.

Current cash price \_\_\_\_\_

Future prices for the months of:

December \_\_\_\_\_

March \_\_\_\_\_

May \_\_\_\_\_

July \_\_\_\_\_

September \_\_\_\_\_

- c. The farmer estimates his cost of hedging, brokerage fee, etc. at \$.35 per bushel. What would be your recommendation to the farmer for marketing his corn?

## UNIT I: AGRICULTURAL BUSINESS MANAGEMENT

### PROBLEM AREA: MARKETING LIVESTOCK AND LIVESTOCK PRODUCTS

#### SUGGESTIONS TO THE TEACHER:

This problem area is designed for use with eleventh grade or advanced students in vocational agriculture programs. The recommended time for teaching this problem area is during the winter months.

The estimated instructional time for this problem area is 5 to 7 days depending on the instructional objectives and the degree to which students are to develop the skills in marketing livestock and livestock products. If the students are to be involved in other marketing exercises, the instructional time will need to be increased.

The instructor is encouraged to conduct a local search to locate other supplementary materials for use with this problem area. The items in this problem area are for reference or modification as instructors adapt these materials to their local situation.

#### CREDIT SOURCES:

These materials were developed through a funding agreement, R-33-13-D-0362-466, with the Illinois State Board of Education, Department of Adult, Vocational and Technical Education, Research and Development Section, 100 North First Street, Springfield, Illinois 62777. Opinions expressed in these materials do not reflect, nor should they be construed as policy or opinion of the State Board of Education or its staff.

The teacher's guide and student worksheets were developed by Coleen Kaczor, Department of Vocational and Technical Education, University of Illinois. The following resources were used in the development of this problem area: Agricultural Economics Curriculum Workshop Packet, Iowa State University and Department of Public Instruction, Department of Agricultural Education, Ames, IA 50011. Transparency masters were prepared by the Vocational Agriculture Service, University of Illinois. Suggestions and guidance in the development of these materials were provided by the Rural Core Curriculum Field Test Teachers. This problem area was reviewed by the following agricultural teachers:

Garry Raymond - Hampshire High School  
Dave Erickson - R.O.V.A. High School  
Vince Mitchell - Mt. Vernon High School  
Larry Keyser - Clay City High School



## TEACHER'S GUIDE

- I. Unit: Agricultural Business Management
- II. Problem area: Marketing livestock and livestock products
- III. Objectives: At the close of this problem area the students will be able to:
  1. Identify terms associated with marketing livestock and livestock products.
  2. Describe the various types of livestock markets.
  3. Analyze the importance of market news, marketing information, trends and cycles.
  4. Identify the purposes of the futures market in relation to marketing livestock and livestock products.
  5. Describe transactions within the futures market.
  6. Solve futures problems on livestock and livestock products.
  7. Solve problems on selling prices of livestock.
- IV. Suggested interest approaches:
  1. Ask the following questions to stimulate interest:
    - a. "How much time and money does the average farmer spend on marketing today?"
    - b. "How many farmers market livestock and livestock products in the top 1/3 of the yearly price range?"
    - c. "Why should farmers have a marketing goal and know their cost of production?"
  2. Write the range of prices farmers have received for livestock and livestock products for the previous year on the chalkboard. Ask students to individually choose the current best price for the various livestock and livestock products.
  3. Have students complete word search on livestock and livestock products.
- V. Anticipated problems and concerns of students:
  1. What are the problems in marketing livestock and livestock products?
  2. What are the different types of livestock markets?

3. Where can marketing information be obtained?
4. What are the trends and cycles in livestock and livestock products marketing?
5. What affects livestock and livestock products prices?
6. What type of competition exists between the different livestock markets?
7. What is the futures market?
8. How does the futures market affect the livestock and livestock products market?
9. What are some terms used in the futures market?
10. What types of transactions occur in the futures market?
11. What information is needed to solve problems to the futures market?
12. What information is needed to determine an appropriate buying price for livestock?

VI. Suggested learning activities and experiences:

1. Conduct an interest approach using one or more of the suggestions in Section IV.
2. Have students identify problems and concerns and then record them on the chalkboard.
3. Have students read resource materials to find answers to their problems and concerns.
4. Have students complete word search worksheet on livestock and livestock products.
5. Have students complete worksheets using VAS Units 2016a, 2029a, 6011, 2023a, 6018 and 6019 during supervised study.
6. Discuss transparencies for problem area.
7. Have students develop a bulletin board of livestock and livestock products being marketed both nationally and internationally.
8. Organize a field trip to:
  - a. Chicago Mercantile Exchange
  - b. A livestock market
  - c. A livestock auction

9. Have students give a short presentation on factors affecting current livestock and livestock products market prices.
10. Have students complete bubble puzzle on livestock and livestock products marketing.
11. Have students identify marketing opportunities throughout Illinois.
12. Divide class into buzz groups and have each group obtain information about a different type of livestock market (Direct, Terminal, Buying Station, Auction and Marketing groups).
13. Have students complete the crossword puzzle on futures terms which are reviewed in Problem Area III-1-2-14.
14. Refer to Problem Area III-1-2 for more general information on futures and transparencies.
15. Have each student select a different livestock product and discuss the marketing techniques used for that particular product.
16. Have students complete livestock and livestock products marketing exercise "Spectacular Bid."
17. Invite a local broker or banker to class as a resource person.
18. Have students complete word problems worksheet on selling prices of livestock.
19. Have students complete futures problems worksheet on livestock and livestock products.
20. Have students complete the Competency Inventory to check their skills.

VII. Application procedures:

1. Students who become involved in marketing livestock and livestock products after high school can apply the knowledge learned from this problem area.
2. Students may use the marketing and futures knowledge in developing more profitable SOE projects.
3. Students may use knowledge learned from this problem area in the farm business management contest.

VIII. Evaluation:

1. Administer test using some or all of the sample questions in this problem area.
2. Evaluate student worksheets and class projects.

3. Evaluate students' livestock and livestock products marketing exercise.

IX. References and aids:

The following materials are available from Vocational Agriculture Service, University of Illinois:

1. VAS Unit 2016a "Marketing Agricultural Products."
2. VAS Unit 2029a "Types of Hog Markets in Illinois."
3. VAS Unit 6011 "Cost to Sell Hogs at Illinois Country Markets."
4. VAS Unit 2023a "Marketing Dairy Products."
5. VAS Unit 6018 "Establishing Prices for Meat Animals."
6. VAS Unit 6019 "Agricultural Markets - Not Necessarily Competitive."

Other materials may be obtained from:

1. 1982 Summary of Illinois Farm Business Records  
Circular 1179  
University of Illinois, College of Agriculture  
Cooperative Extension Services  
Urbana, Illinois 61801
2. Modern Marketing of Farm Products  
Interstate Printers and Publishers  
Danville, Illinois
3. Chicago Mercantile Exchange  
Agricultural Commodities Marketing Department  
444 West Jackson Boulevard  
Chicago, Illinois 60606
  - a. The Marketplace - Student Workbook
  - b. The Marketplace - Teacher's Guide
  - c. Commodity Paper Trading Exercise
  - d. Quizzes for the Marketplace Workbook

413

## COMPETENCY INVENTORY

### MARKETING LIVESTOCK AND LIVESTOCK PRODUCTS

1. Student has no knowledge of competency.
2. Student has read about competency.
3. Student has seen competency performed.
4. Student has performed competency.
5. Student has performed competency without supervision.
6. Student does possess skill.
7. Student does not possess skill.

Competency	Circle One				
1. Describe the difference between hedging and speculation.	1	2	3	4	5
2. Outline the procedures involved in buying and/or selling futures contracts.	1	2	3	4	5
3. Describe the types of livestock markets.	1	2	3	4	5
4. Identify livestock and livestock products marketing trends.	1	2	3	4	5
5. Identify the importance of competition among livestock markets.	1	2	3	4	5
6. List factors that affect livestock prices.	1	2	3	4	5
7. Identify terms associated with marketing livestock and livestock products.	1	2	3	4	5
8. Describe regulations that control the futures market.	1	2	3	4	5
9. Outline the development of the futures market.	1	2	3	4	5
10. Identify the purpose of the futures market.	1	2	3	4	5
11. Identify the possible uses of hedging by the farmer.	1	2	3	4	5
12. Outline the importance of exports and imports on livestock and livestock products.	1	2	3	4	5
13. Interpret what it meant by "margin money" and how this is determined.					6 7
14. Interpret governmental influence on livestock marketing.					6 7
15. Analyze the importance of market news and marketing information.					6 7
16. Analyze the role of the futures market and its effect upon livestock and livestock products prices on the farm.					6 7

These competencies were outlined in the National Ag Occupations Competency Study, for entry level positions in agriculture.

Name \_\_\_\_\_ Date \_\_\_\_\_

## STUDENT WORKSHEET 1

### SPECULATOR BID

#### Objectives:

1. Students are to interpret factors affecting price changes.
2. Students are to chart daily market changes.
3. Students are to understand the principle of risk in speculation.
4. Students are to become more motivated for studying the unit on livestock marketing.

#### Materials:

1. Graph paper.
2. Local daily paper with markets--or--
3. A recording of the evening/morning market report.

#### Time Period:

1. Begin charting three weeks prior to the unit on marketing.
2. Maintain chart for at least 6-7 weeks.

#### Procedures:

1. Each student is given contracts in:
  - feeder cattle--each contract is for 44,000 lbs.
  - hogs--live--each contract is for 30,000 lbs.
2. Students begin charting the daily prices for each contract month.
3. During the simulation the students are to buy and sell the contracts, just as a speculator would do.
4. The student making the most money at the end of the game receives extra credit points.
5. Open markets for only 5 minutes each class day, so as not to take too much time away from other topics.

## STUDENT WORKSHEET 2

### LIVESTOCK AND LIVESTOCK PRODUCTS WORD SEARCH

M S F S Q T I C E C R E A M C A S B M A L U  
S M A B R D Q J A V O S V R E B W H N O A Q L  
M U R R E D C K E Y O G S V R E A T P N C A C I  
U R E T M L U E A T H O G R E K A N C A E X P L  
R T A E L U H A R P R O S B I T G L A C E P H I  
T T I L C H A R P R O S B I T G L A C E P H I  
O N E R L O R A O S B I T G L A C E P H I  
X S Y A Q I P R O S B I T G L A C E P H I  
E T C M E L V A A P F H  
H C H E E A H G S T E V L E A M C A S B M A L  
U M D A I R Y P R O D U C T S L V F L K R

#### WORDS FOR SEARCH

CATTLE  
BEEF  
HOGS  
DAIRY PRODUCTS  
SHEEP  
LAMBS  
MUTTON  
FEEDERS  
MEAT PACKERS  
WHOLESALERS  
RETAILERS  
BOXED BEEF  
ICE CREAM  
YOGURT

CALVES  
FEEDLOT  
AUCTION  
MARKETS  
PORK  
VEAL  
SAUSAGE  
CANNED MEAT  
LARD  
HIDES  
MILK  
CHEESE  
BUTTER

# STUDENT WORKSHEET 3

## LIVESTOCK MARKETING CROSSWORD PUZZLE

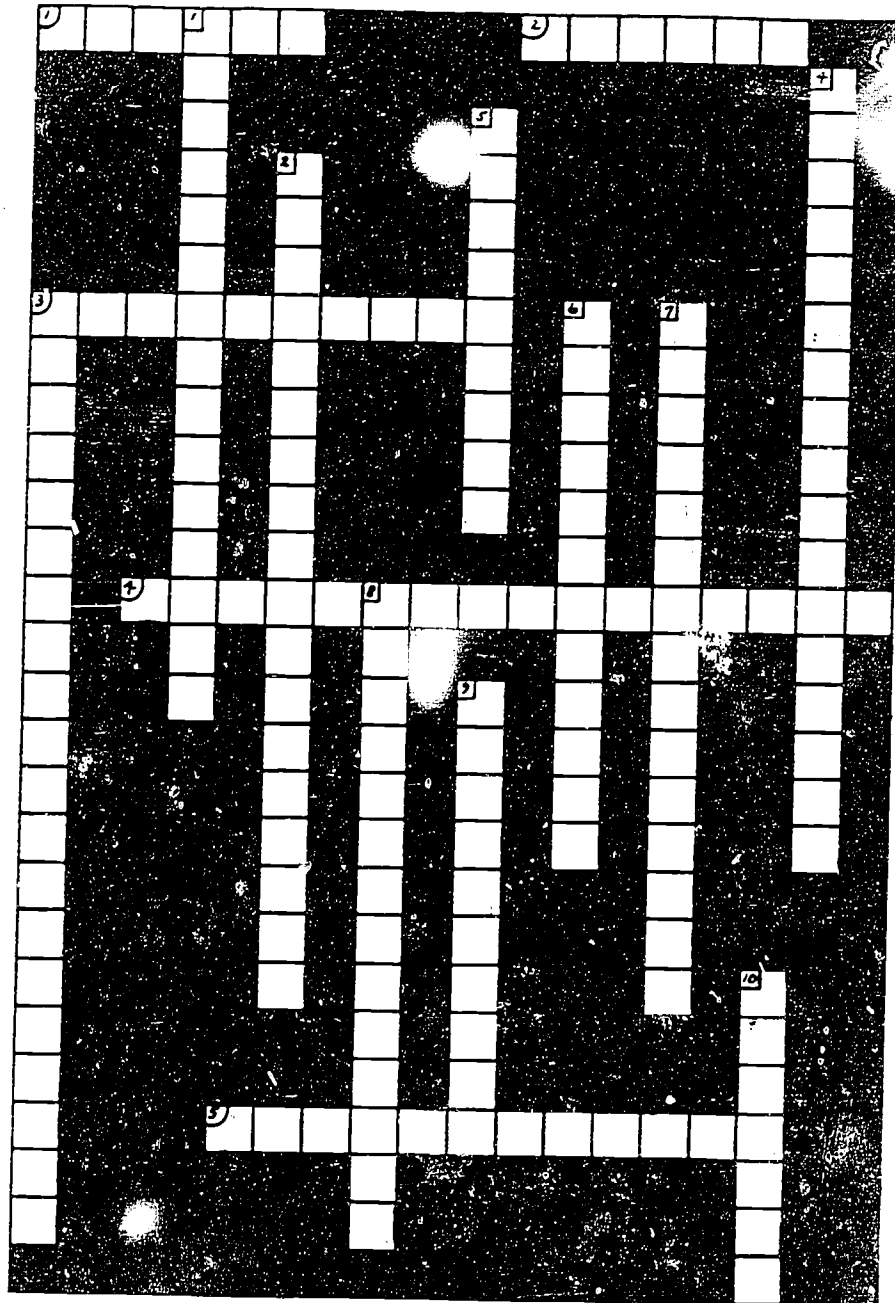



## STUDENT WORKSHEET 3

### LIVESTOCK MARKETING CROSSWORD PUZZLE (cont'd.)

#### ACROSS

1. An individual, not a market agency, engaged in the business of buying or selling livestock for his own account, usually on a speculative basis.
2. The quantity of a product that is placed on the market at any given time.
3. A fee or a charge paid by the seller to an agent for selling services; or a fee charge paid by the purchaser to an agent for the buying of cattle.
4. A trading center where livestock is assembled at regular intervals and sold by public bidding.
5. A facility operated privately and solely by a packer or slaughterer where livestock is purchased directly from the producer for slaughter.

#### DOWN

1. The transfer of ownership of livestock from the seller to the purchaser without the service of an agency.
2. The percentage yield of chilled carcass in relation to the weight of the animal on foot.
3. A method of selling livestock in which the service is performed by, or on behalf of, a voluntary association of livestock producers.
4. A market agency that receives livestock on consignment to be sold on an agency basis for an established fee.
5. The loss in weight of the animals caused by the movement of livestock from one place to another.
6. An agency engaged in the business of buying or selling livestock on a commission basis.
7. The agreement between an owner and a buyer on the price of livestock setting forth the provisions relating to the description, delivery date, weighing point, and delivery point prior to the delivery of the livestock.
8. A trading center where facilities are provided for receiving, caring for, and handling livestock; where several selling agencies are in operation; and where the privileges of buying and selling are available to all who wish to use them.
9. A term applied to an individual who purchases livestock for others.
10. A market on which livestock are displayed in a ring and offered for sale to all buyers to the highest bidder.

## STUDENT WORKSHEET 4

### ESTABLISHING PRICES FOR MEAT ANIMALS (For use with VAS Unit 2016a)

#### I. True/False:

- \_\_\_\_\_ 1. Prices are the result of interaction of supply and demand.
- \_\_\_\_\_ 2. Market supply is defined as the quantity of any commodity that will be bought in a given place at a particular time and at a given price.
- \_\_\_\_\_ 3. Assembling is a necessary part of the marketing process and adds value to the commodity produced.
- \_\_\_\_\_ 4. To sort a produce there must be difference of grade.
- \_\_\_\_\_ 5. Manufacturing includes all operations that change the form of a product.

#### ii. Short Answer:

1. What factors affect market supply?
  - a.
  - b.
  - c.
  - d.
  - e.
2. What factors affect market demand?
  - a.
  - b.
  - c.
  - d.
3. What are the two kinds of market information needed?
  - a.
  - b.
4. How can storage be useful to the farmer?
  - a.
  - b.
  - c.

5. Today's goods are transported by

- a.
- b.
- c.
- d.

455

STUDENT WORKSHEET 5

AGRICULTURAL MARKETS - NOT NECESSARILY COMPETITIVE  
(For use with VAS Unit 6019)

Fill in the blank:

1. Since \_\_\_\_\_ a "Laissez-faire" economic system has been advocated by many classical economists.
2. Adam Smith's " \_\_\_\_\_ " assumed no government intervention or interference.
3. The government has encouraged collective bargaining between \_\_\_\_\_ and \_\_\_\_\_.
4. Small individual farmers are " \_\_\_\_\_ " not " \_\_\_\_\_ ".
5. Theoretically, as supply increases, prices \_\_\_\_\_, as supply \_\_\_\_\_ prices rise, as demand increases prices \_\_\_\_\_, and as demand \_\_\_\_\_ prices fall.
6. The nerve center guiding various marketing aspects is the \_\_\_\_\_.
7. The livestock marketing structure has been in a constant state of \_\_\_\_\_.
8. Both \_\_\_\_\_ and \_\_\_\_\_ market systems reflect orders from the same basic packer buyers.
9. The limiting factor in today's market is \_\_\_\_\_ management \_\_\_\_\_.
10. The \_\_\_\_\_ is recognized as the turning point in agricultural philosophy which persisted since 1933.

STUDENT WORKSHEET 6

ESTABLISHING PRICES FOR MEAT ANIMALS  
(For use with VAS Unit 6018)

True/False:

- \_\_\_\_\_ 1. Mobility for the owner is the freedom to either sell his/her stock or take it home as he/she desires.
- \_\_\_\_\_ 2. Marketing costs (margins) represent payment for services rendered.
- \_\_\_\_\_ 3. Holidays do influence market demand.
- \_\_\_\_\_ 4. A "long" supply means lower prices.
- \_\_\_\_\_ 5. Overall demand for meat is determined by the accumulation of stocks in packing plant coolers.

Short answer:

6. List the formal sources of marketing information.
- a.
  - b.
  - c.
  - d.
  - e.
  - f.
  - g.
  - h.
7. List the informal sources of marketing information.
- a.
  - b.
  - c.
  - d.
  - e.
  - f.
  - g.
8. List the governmental source of marketing information.
- a.
9. List and define the three classifications used for truck load shipments.
- a.
  - b.
  - c.

## STUDENT WORKSHEET 7

### TYPES OF HOG MARKETS IN ILLINOIS (For use with VAS Unit 2029a)

Fill in the blanks:

1. To the livestock producer, the first buyer is the \_\_\_\_\_.
2. The livestock market is influenced by \_\_\_\_\_ in our economy.
3. In 1920, the flow of livestock moved to \_\_\_\_\_ and \_\_\_\_\_, Illinois because the nation's railroads converged there.
4. Presently \_\_\_\_\_ is the largest volume Illinois hog market.
5. All of the local country markets receive \_\_\_\_\_ buying instructions either from their \_\_\_\_\_ or directly from their \_\_\_\_\_.

True/False:

- \_\_\_\_\_ 6. In practice the pricing system of the livestock is simple to understand.
- \_\_\_\_\_ 7. The critical problem in the whole reorganization is the lack of market representation on the live animal supply side of the market.
- \_\_\_\_\_ 8. Price differences occur within the same weight classes of hogs sold in different areas of the state during all seasons of the year.
- \_\_\_\_\_ 9. In the functional approach you consider what organizations, middlemen, or facilitating agencies perform the marketing functions.
- \_\_\_\_\_ 10. The commodity approach would be a study of hogs and how they are moved from the producer to the consumer.

Short answer:

11. List the criteria for a good pricing system:
  - a.
  - b.
  - c.
  - d.

e.

f.

g.

12. What are the three different approaches used to study the Illinois hog market?

a.

b.

c.

## STUDENT WORKSHEET 8

### COST TO SELL HOGS AT ILLINOIS COUNTRY MARKETS (For use with VAS Unit 6011)

True/False:

- \_\_\_\_\_ 1. The high-cost country markets are the final step in the evolution of an integrated livestock-marketing system.
- \_\_\_\_\_ 2. The newer system of live-animal production, assembly, processing, and distribution operates closer to the areas of surplus feed production.
- \_\_\_\_\_ 3. Operational costs are covered by the packer.
- \_\_\_\_\_ 4. In the study of 48 hog markets, the major cost item was yard and barn expenses.
- \_\_\_\_\_ 5. Unit operational costs are inversely related to market throughput.
- \_\_\_\_\_ 6. Physical capacity was defined as that market volume at which the average cost was the lowest.
- \_\_\_\_\_ 7. Country-point marketing is not costly.
- \_\_\_\_\_ 8. If country markets hold hogs overnight for shipment this adds additional expenses to the cost of operation.
- \_\_\_\_\_ 9. Large scale commercial hog producing operations tend to utilize both the terminal and country hog markets.
- \_\_\_\_\_ 10. Commission and service fees do not cover country market operating costs.



STUDENT WORKSHEET 9

MARKETING DAIRY PRODUCTS  
(For use with VAS Unit 2023a)

Fill in the blanks:

1. The total volume of milk needed for commercial sales in the United States depends primarily on (1) \_\_\_\_\_, (2) \_\_\_\_\_, and (3) \_\_\_\_\_.
2. Along with fewer milk producers, there has been a sharp decrease in the number of \_\_\_\_\_.
3. In Illinois, all milk sold for fluid consumption has to be \_\_\_\_\_.
4. The \_\_\_\_\_ is derived by taking the total dollars received from the sale of milk each month and dividing these by the total volume of milk received.
5. The major opportunity for expanding markets for milk by an individual farmer or a group of farmers is through a \_\_\_\_\_ or through the initiative of the \_\_\_\_\_ to whom he/she sells his/her milk.

Short Answer:

6. List the principal purposes of federal-order regulation.
  - a.
  - b.
7. List the favorable factors affecting the dairy industry.
  - a.
  - b.
  - c.
  - d.
  - e.
  - f.

461

8. List the unfavorable factors affecting the dairy industry.

a.

b.

c.

d.

e.

f.

## STUDENT WORKSHEET 10

### CALCULATE SHRINKAGE AND SELLING PRICES

1. Suppose you sold 10 Angus steers direct to a feeder to be delivered at the local livestock auction for weighing. You agreed on \$38.50 hundred weight price and gave a 3% shrinkage. Upon weighing your calves, they averaged 575 lbs. What would be the total dollars received for your steers?
2. You sold 9 Hereford steers to the local livestock auction. The steers averaged 375 lbs. and brought \$40.00 per hundred weight. How much money did you receive for the steers?
3. You sold 5 Hereford heifers for \$38.00 per hundred weight, and they averaged 550 lbs. What was the amount of money you received?
4. Suppose you had the option to sell 125 head of steers either at the local livestock auction or at a terminal market which is 100 miles from your farm. According to the information at the terminal market, steers similar to yours are bringing \$38.00 per hundred weight. You estimated that the steers would weigh 575 lbs. on the average. Last week's local livestock auction was 75 cents lower than the terminal market. Using an estimated shrinkage of 4% on hauling to the terminal market and selling for \$38.00 per hundred weight, would it be more profitable to sell at the livestock auction or at the terminal market? Why?

43

STUDENT WORKSHEET 11

CALCULATE SELLING PRICE

1. You sold 5 market hogs which graded U.S. No. 1. The hogs averaged 200 lbs. live weight, and the carcasses averaged 150 lbs. What was the percent yield?

2. You sold two Angus steers at a price of 50 cents per pound. The steers average live weight was 950 lbs. What was the value of the steers?

3. You sold 10 Hereford steers which averaged 1150 lbs. live weight and hung up a 715 lb. carcass. What would be the percent yield of the steers?

Using a price of \$60.00 per hundred weight, what would the steers' value be?

# STUDENT WORKSHEET 12

## FUTURES BUBBLE PUZZLE

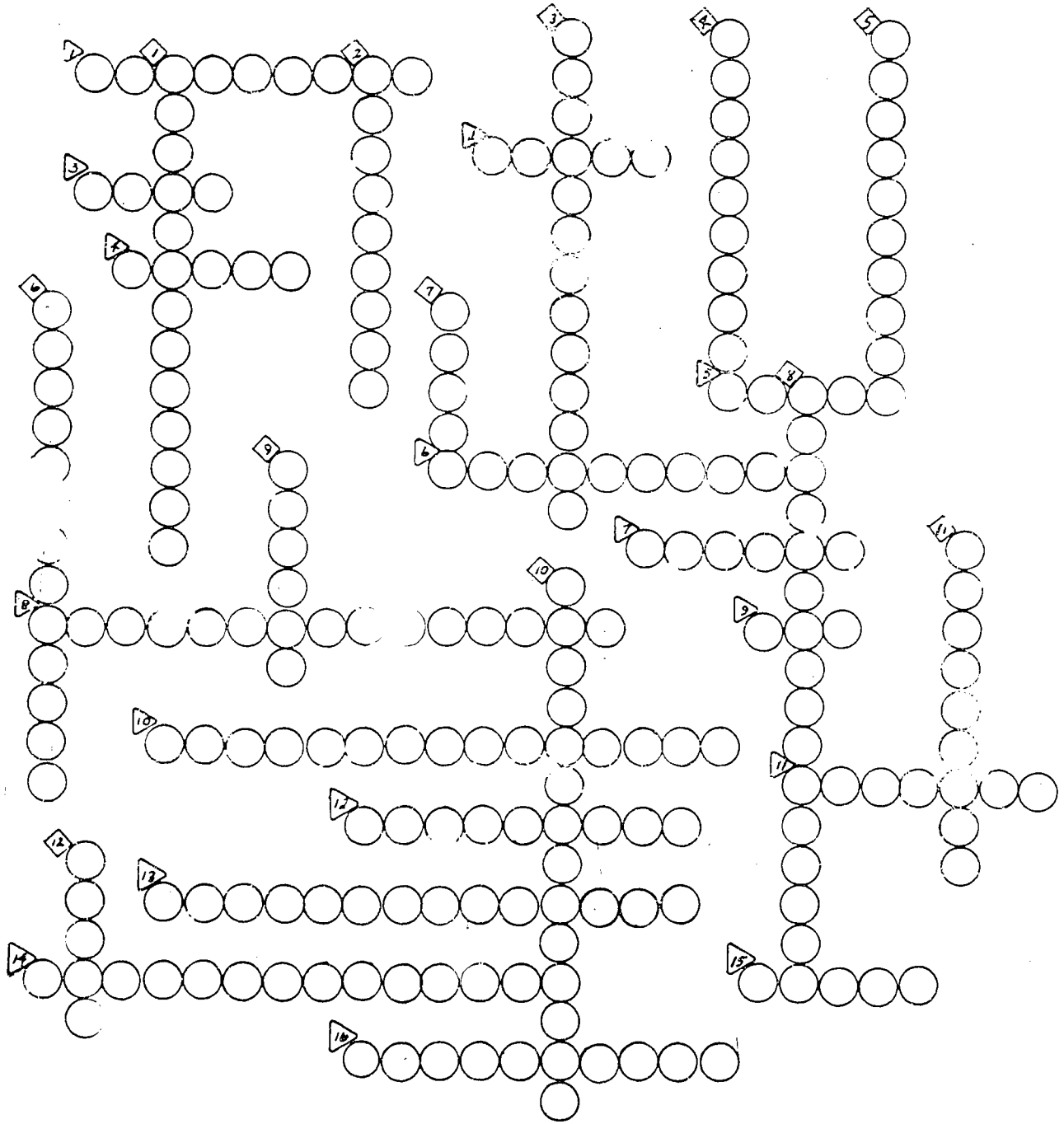

STUDENT WORKSHEET 12

FUTURES BUBBLE PUZZLE  
(cont'd.)

ACROSS

1. The price at which a physical commodity is selling at a given time and place.
2. The minimum price fluctuation in futures. It is equal to 1/100 of one cent in most futures traded in decimal units. In grains, it is 1/8 of one cent.
3. One who has bought grain: also one who is on the buying side of an open (unhedged) futures contract.
4. The purchase of futures to offset a previously established short position.
5. The maximum price advance or decline from the previous day's settlement price permitted in one trading session by the rules of the exchange.
6. One who attempts to anticipate price changes and through market activities makes profits, and who is not hedging.
7. An agent entrusted with the execution of an order. This person may be employed in the office of the commission house that carries the account or a floor broker or pit broker who actually executes the order on the trading floor.
8. The difference between the amount consumers pay for the final product and the amount producers receive.
9. A price offered subject, unless otherwise stated, to immediate acceptance for a specific amount of commodity.
10. An agreement to buy and receive or sell and deliver a commodity at a future date with certain specified characteristics.

DOWN

1. Contracts which have been brought or sold without the transaction having been completed by subsequent sale or repurchase, or actual delivery or receipt of commodity.
2. Goods that can be bought and/or sold.
3. The price fixed by the Clearing House at which deliveries on futures are invoiced and also the price at which the futures contract is settled when deliveries are made.
4. A request to deposit either the original margin at the time of the transaction, or to restore the guarantee to "maintenance margin" levels required for the duration of the time the contract is held.
5. One where large supplies and/or poor demand cause a decline in price.
6. The calendar month during which a futures contract matures.
7. The spread or difference between the spot or "cash" price and the price of a specified futures delivery month price, or may also be used to designate price differentials between "cash" and more distant futures delivery months, as well as different locations as specified.
8. The route that a commodity takes on its way from the producer to the ultimate consumer.

## ACROSS

11. Is the sale of futures when holding the physical commodity or its equivalent, as protection against a price decline; or the purchase of futures against forward sales or anticipated requirements of the physical commodity as protection against a price advance.
12. In trading, the definite price stated by a customer to a broker restricting the execution of an order to buy for not more than or to sell for not less than the stated price.
13. Those locations designated by commodity covered by a futures contract may be delivered in fulfillment of the contract.
14. The notification of delivery of the actual commodity on the contract, issued by the seller of the futures to the Clearing House.
15. The period at the end of the futures trading session during which all trades are officially declared as having been executed "at or on the close." The closing range is the range of prices on trades made during this designated period.
10. One where small supplies and/or strong demand causes prices to rise.

## DOWN

9. The amount deposited by buyers and sellers of futures, to insure performance on contracts commitments; serves as a performance bond rather than a "down-payment."
10. The first day on which notices of intentions to deliver actual commodities against futures contract positions can be made received. First notice day will vary with each commodity and exchange. It usually precedes the beginning of the delivery period.
11. All of the processes and services involved in moving a commodity from the producer to the ultimate consumer. The activity involved in buying or selling a product.
12. A purchaser of a commodity offered for sale or exchange.

\*Selected from National FFA Contests, Bulletin No. 4, 1982/1983/1984, pages 26-32, Kansas City, Missouri

STUDENT WORKSHEET #13

MARKET INFORMATION

Using the statements below, collect the livestock market information from a newspaper and/or a trip to the auction. When completed, answer the questions at the end of this worksheet.

I. TERMINAL MARKET DATA

Cattle and calves No. \_\_\_\_\_ head

Activity of the market \_\_\_\_\_

Price range

Slaughter steers \_\_\_\_\_

Weights \_\_\_\_\_

Weights \_\_\_\_\_

Slaughter heifers \_\_\_\_\_

Weights \_\_\_\_\_

Weights \_\_\_\_\_

Slaughter cows \_\_\_\_\_

Bulls \_\_\_\_\_

Slaughter calves \_\_\_\_\_

Feeder cattle \_\_\_\_\_

Feeder calves \_\_\_\_\_

Cow-calf pairs \_\_\_\_\_

Hogs No. \_\_\_\_\_ head

Activity of market \_\_\_\_\_

Price range

U.S.No.1 \_\_\_\_\_ Weight \_\_\_\_\_

U.S.No.2 \_\_\_\_\_ Weight \_\_\_\_\_

U.S.No.3 \_\_\_\_\_ Weight \_\_\_\_\_

U.S.No.4 \_\_\_\_\_ Weight \_\_\_\_\_

II. LOCAL AUCTION

Cattle and calves No. \_\_\_\_\_ head

Activity of the market \_\_\_\_\_

Price range

Slaughter steers \_\_\_\_\_

Weights \_\_\_\_\_

Weights \_\_\_\_\_

Slaughter heifers \_\_\_\_\_

Weights \_\_\_\_\_

Weights \_\_\_\_\_

Slaughter cows \_\_\_\_\_

Bulls \_\_\_\_\_

Slaughter calves \_\_\_\_\_

Feeder cattle \_\_\_\_\_

Feeder calves \_\_\_\_\_

Cow-calf pairs \_\_\_\_\_

Hogs No. \_\_\_\_\_ head

Activity of market \_\_\_\_\_

Price range

U.S.No.1 \_\_\_\_\_ Weight \_\_\_\_\_

U.S.No.2 \_\_\_\_\_ Weight \_\_\_\_\_

U.S.No.3 \_\_\_\_\_ Weight \_\_\_\_\_

U.S.No.4 \_\_\_\_\_ Weight \_\_\_\_\_



II. Questions: (Refer to data collected from the terminal market and local auction)

1. What is the difference in prices between the terminal market and the local auction? What might be the cause of these differences?

2. Would you sell your livestock at the terminal market or local auction? Why? (Be sure to include all factors affecting the price of marketing livestock.)

483

TEACHER'S KEY  
STUDENT WORKSHEET 2  
LIVESTOCK AND LIVESTOCK PRODUCTS  
WORD SEARCH

M S F S O T I C E C R E A M C A S B M B A S I B A Q M N A A I  
S M B R D R C K J V O S G S V R E B A W H N O A L I T L S P A H T F E E D E R S Y M T L E R  
U R E I M L U E E T E P R O W M A T O Y A T E S B O U I P N K B C U P E O L G  
R T T A C H A R A O U I P R T Y O H B E E  
T O N O X S T G M H S E D I H  
L E R I L E R S Y A M E L V A A P C H  
L G M L A Q I A M E W I F F H  
A R A O U I P R T Y O H B E E  
O W S C O K P O K O L E  
D K H M I A R I A C Y L K D H  
B O U I P N K B C U P E O L G  
M E X E T E A  
L Y E A D V E R S I O H L  
G L T O G L T M O R S I S E O L  
S B S E N M A I O R L N A  
A C E U X T U G S T H B D E P M P E M  
S T F E E D E R S Y M T L E R  
C O O A C E U X T U G S T H B D E P M P E M  
S I T L S Y E Y P T C T S S C O E E D E L E  
B O C P T R J W J U G O F T G K M A C O K  
M N U B O X E D B E E F M A B E E F E T I  
A Q U E B E O K V K X B I A E O P S E E A S O  
I A I R Y P R O D U C T S L V P L K R

WORDS FOR SEARCH

- |                |             |
|----------------|-------------|
| CATTLE         | CALVES      |
| BEEF           | FEEDLOT     |
| HOGS           | AUCTION     |
| DAIRY PRODUCTS | MARKETS     |
| SHEEP          | PORK        |
| LAMBS          | VEAL        |
| MUTTON         | SAUSAGE     |
| FEEDERS        | CANNED MEAT |
| MEAT PACKERS   | LARD        |
| WHOLESALEERS   | HIDE        |
| RETAILERS      | MILK        |
| BOXED BEEF     | CHEESE      |
| ICE CREAM      | BUTTER      |
| YOGURT         |             |



## TEACHER'S KEY

### STUDENT WORKSHEET 3

#### LIVESTOCK MARKETING CROSSWORD PUZZLE (cont'd.)

##### ACROSS

1. An individual, not a market agency, engaged in the business of buying or selling livestock for his own account, usually on a speculative basis.
2. The quantity of a product that is placed on the market at any given time.
3. A fee or a charge paid by the seller to an agent for selling services; or a fee charge paid by the purchaser to an agent for the buying of cattle.
4. A trading center where livestock is assembled at regular intervals and sold by public bidding.
5. A facility operated privately and solely by a packer or slaughterer where livestock is purchased directly from the producer for slaughter.

##### DOWN

1. The transfer of ownership of livestock from the seller to the purchaser without the service of an agency.
2. The percentage yield of chilled carcass in relation to the weight of the animal on foot.
3. A method of selling livestock in which the service is performed by, or on behalf of, a voluntary association of livestock producers.
4. A market agency that receives livestock on consignment to be sold on an agency basis for an established fee.
5. The loss in weight of the animals caused by the movement of livestock from one place to another.
6. An agency engaged in the business of buying or selling livestock on a commission basis.
7. The agreement between an owner and a buyer on the price of livestock setting forth the provisions relating to the description, delivery date, weighing point, and delivery point prior to the delivery of the livestock.
8. A trading center where facilities are provided for receiving, caring for, and handling livestock; where several selling agencies are in operation; and where the privileges of buying and selling are available to all who wish to use them.
9. A term applied to an individual who purchases livestock for others.
10. A market in which livestock are displayed in a ring and offered for sale to all buyers to the highest bidder.

TEACHER'S KEY

STUDENT WORKSHEET 4

ESTABLISHING PRICES FOR MEAT ANIMALS  
(For use with VAS Unit 2016a)

I. True/False:

- True 1. Prices are the result of interaction of supply and demand.
- False 2. Market supply is defined as the quantity of any commodity that will be bought in a given place at a particular time and at a given price.
- False 3. Assembling is a necessary part of the marketing process and adds value to the commodity produced.
- True 4. To sort a produce there must be difference of grade.
- False 5. Manufacturing includes all operations that change the form of a product.

II. Short Answer:

1. What factors affect market supply?
  - a. weather
  - b. pests
  - c. storage facilities
  - d. adequate transportation
  - e. desire of a producer to sell
2. What factors affect market demand?
  - a. consumer preference
  - b. price
  - c. per capita consumption
  - d. changes in population
3. What are the two kinds of market information needed?
  - a. the kind of market most profitable to use
  - b. long time price trends and changes in current prices
4. How can storage be useful to the farmer?
  - a. marketability all through the year,
  - b. prevents seasonal surpluses, and
  - c. encourages orderly marketing.

5. Today's goods are transported by

- a. railroad
- b. truck
- c. plane
- d. barge (water)

TEACHER'S KEY

STUDENT WORKSHEET 5

AGRICULTURAL MARKETS - NOT NECESSARILY COMPETITIVE  
(For use with VAS Unit 6019)

Fill in the blank:

1. Since Adam Smith a "Laissez-faire" economic system has been advocated by many classical economists.
2. Adam Smith's "free market" assumed no government intervention or interference.
3. The government has encouraged collective bargaining between labor and management.
4. Small individual farmers are "price takers" not "price makers".
5. Theoretically, as supply increases, prices fall, as supply decreases prices rise, as demand increases prices rise, and as demand decreases prices fall.
6. The nerve center guiding various marketing aspects is the market pricing system.
7. The livestock marketing structure has been in a constant state of transition.
8. Both terminal and country market systems reflect orders from the same basic packer buyers.
9. The limiting factor in today's market is management.
10. The Agricultural Act of 1973 is recognized as the turning point in agricultural philosophy which persisted since 1933.

TEACHER'S KEY

STUDENT WORKSHEET 6

ESTABLISHING PRICES FOR MEAT ANIMALS  
(For use with VAS Unit 6018)

True/False:

- True 1. Mobility for the owner is the freedom to either sell his/her stock or take it home as he/she desires.
- True 2. Marketing costs (margins) represent payment for services rendered.
- True 3. Holidays do influence market demand.
- True 4. A "long" supply means lower prices.
- False 5. Overall demand for meat is determined by the accumulation of stocks in packing plant coolers.

Short answer:

6. List the formal sources of marketing information.
- integrated marketing agencies
  - commercial feedlots
  - processors and distributors
  - wholesale and retail chains
  - federal and state market news reporting agency
  - trade papers
  - marketing magazines and journals
  - house organs
7. List the informal sources of marketing information.
- word of mouth
  - spot radio reports
  - telephone
  - truckers
  - fieldmen for marketing
  - promotional publicity of retail firms
  - organized meetings
8. List the governmental source of marketing information.
- United States Department of Agriculture
9. List and define the three classifications used for truck load shipments.
- Trade - shipped to sales units that sell locally. They go through district channels.
  - HRI - for hotel, restaurant, and institution trade.
  - FS - forward sales for chain store use.



## TEACHER'S KEY

### STUDENT WORKSHEET 7

#### TYPES OF HOG MARKETS IN ILLINOIS (For use with VAS Unit 2029a)

Fill in the blanks:

1. To the livestock producer, the first buyer is the market.
2. The livestock market is influenced by technical developments in our economy.
3. In 1920, the flow of livestock moved to St. Louis and Chicago, Illinois because the nation's railroads converged there.
4. Presently St. Louis is the largest volume Illinois hog market.
5. All of the local country markets receive daily buying instructions either from their parent organization or directly from their packer buyer.

True/False:

- False 6. In practice the pricing system of the livestock is simple to understand.
- True 7. The critical problem in the whole reorganization is the lack of market representation on the live animal supply side of the market.
- True 8. Price differences occur within the same weight classes of hogs sold in different areas of the state during all seasons of the year.
- False 9. In the functional approach you consider what organizations, middlemen, or facilitating agencies perform the marketing functions.
- True 10. The commodity approach would be a study of hogs and how they are moved from the producer to the consumer.

Short answer:

11. List the criteria for a good pricing system:
  - a. develop prices that reflect to producers the basic demands of consumers as to kind, quantity and quality of goods,
  - b. reflect prices that will move existing and forthcoming supplies through the channels of trade and/or into consumption of the highest possible net returns,
  - c. provide a price structure that maintains economically justified stocks both within and between marketing seasons;

- d. be impartial and treat all producers and consumers alike,
  - e. reflect the quality differences recognized by the trade and consumers,
  - f. not be subject to manipulation, and
  - g. do all of the above economically and efficiently.
12. What are the three different approaches used to study the Illinois hog market?
- a. commodity
  - b. functions or services performed in getting the hogs from the farm to the consumer
  - c. marketing agencies or institutions that handle the hogs as they perform the services and functions

TEACHER'S KEY.

STUDENT WORKSHEET 8

COST TO SELL HOGS AT ILLINOIS COUNTRY MARKETS  
(For use with VAS Unit 6011)

True/False:

- False 1. The high-cost country markets are the final step in the evolution of an integrated livestock-marketing system.
- True 2. The newer system of live-animal production, assembly, processing, and distribution operates closer to the areas of surplus feed production.
- True 3. Operational costs are covered by the packer.
- False 4. In the study of 48 hog markets, the major cost item was yard and barn expenses.
- True 5. Unit operational costs are inversely related to market throughput.
- True 6. Physical capacity was defined as that market volume at which the average cost was the lowest.
- False 7. Country-point marketing is not costly.
- True 8. If country markets hold hogs overnight for shipment this adds additional expenses to the cost of operation.
- False 9. Large scale commercial hog producing operations tend to utilize both the terminal and country hog markets.
- True 10. Commission and service fees do not cover country market operating costs.

470

TEACHER'S KEY  
STUDENT WORKSHEET 9  
MARKETING DAIRY PRODUCTS  
(For use with VAS Unit 2023a)

Fill in the blanks:

1. The total volume of milk needed for commercial sales in the United States depends primarily on (1) changes in population, (2) changes in purchasing power, and (3) changes in per capita consumption.
2. Along with fewer milk producers, there has been a sharp decrease in the number of milk cows.
3. In Illinois, all milk sold for fluid consumption has to be Grade A.
4. The blend price is derived by taking the total dollars received from the sale of milk each month and dividing these by the total volume of milk received.
5. The major opportunity for expanding markets for milk by an individual farmer or a group of farmers is through a farmers cooperative or through the initiative of the milk dealer to whom he/she sells his/her milk.

Short Answer:

6. List the principal purposes of federal-order regulation.
  - a. to insure consumers an adequate supply of high quality milk. Accomplished by setting up pricing mechanisms that insure equity to farmers and distributors.
  - b. substitute orderly marketing for the chaos and confusion existing before regulation.
7. List the favorable factors affecting the dairy industry.
  - a. steady increase in population,
  - b. steady increase in purchasing power of consumers,
  - c. increase in per capita consumption of frozen dairy products in nonfat dry milk solids,
  - d. development of new low-cost methods for distributing milk,
  - e. inventive group of scientists whose new products benefit consumers as well as the dairy industry,
  - f. continuation of increased efficiency in producing milk.

TEACHER'S KEY  
STUDENT WORKSHEET 10

CALCULATE SHRINKAGE AND SELLING PRICES

1. Suppose you sold 10 Angus steers direct to a feeder to be delivered at the local livestock auction for weighing. You agreed on \$38.50 hundred weight price and gave a 3% shrinkage. Upon weighing your calves, they averaged 575 lbs. What would be the total dollars received for your steers?

$$575 - 17 = 558 \times 38.50 = \$214.83 \text{ per steer or } \$2,148.30$$

2. You sold 9 Hereford steers to the local livestock auction. The steers averaged 375 lbs. and brought \$40.00 per hundred weight. How much money did you receive for the steers?

$$375 \times \$40.00 = 150.00 \text{ per steer or } \$1,350.00$$

3. You sold 5 Hereford heifers for \$38.00 per hundred weight, and they averaged 550 lbs. What was the amount of money you received?

$$550 \times 38.00 = \$209.00 \text{ per steer or } \$1045.00$$

4. Suppose you had the option to sell 125 head of steers either at the local livestock auction or at a terminal market which is 100 miles from your farm. According to the information at the terminal market, steers similar to yours are bringing \$38.00 per hundred weight. You estimated that the steers would weigh 575 lbs. on the average. Last week's local livestock auction was 75 cents lower than the terminal market. Using an estimated shrinkage of 4% on hauling to the terminal market and selling for \$38.00 per hundred weight, would it be more profitable to sell at the livestock auction or at the terminal market? Why?

Local livestock auction

You would be losing 23 lbs. per steer on shrinkage, plus what the truck would cost.

Terminal Market

$$575 \times 23 = 552 \times 38.00 = \$209.76 \text{ per steer or } \$26,220.00 \text{ for the } 125 \text{ head}$$

Local livestock auction

$$575 \times 37.25 = \$214.19 \text{ per steer or } \$26,773.75 \text{ for the } 125 \text{ head}$$

TEACHER'S KEY

STUDENT WORKSHEET 11

CALCULATE SELLING PRICE

1. You sold 5 market hogs which graded U.S. No. 1. The hogs averaged 200 lbs. live weight, and the carcasses averaged 150 lbs. What was the percent yield?

$$\frac{150 \text{ lbs.}}{200 \text{ lbs.}} \times 100 = 75 \text{ percent yield}$$

2. You sold two Angus steers at a price of 50 cents per pound. The steers average live weight was 950 lbs. What was the value of the steers?

$$950 \text{ lbs.} \times .50 \times 2 = \$950.00 \text{ for two steers.}$$

3. You sold 10 Hereford steers which averaged 1150 lbs. live weight and hung up a 715 lb. carcass. What would be the percent yield of the steers?

Using a price of \$60.00 per hundred weight, what would the steers' value be?

A.  $\frac{715 \text{ pounds}}{1150 \text{ pounds}} \times 100 = 62 \text{ percent yield}$

B.  $1150 \text{ lbs.} \times \$ .60 \times 10 \text{ head} = \$6,900.00$

TEACHER'S KEY  
 STUDENT WORKSHEET 12  
 FUTURES BUBBLE PUZZLE

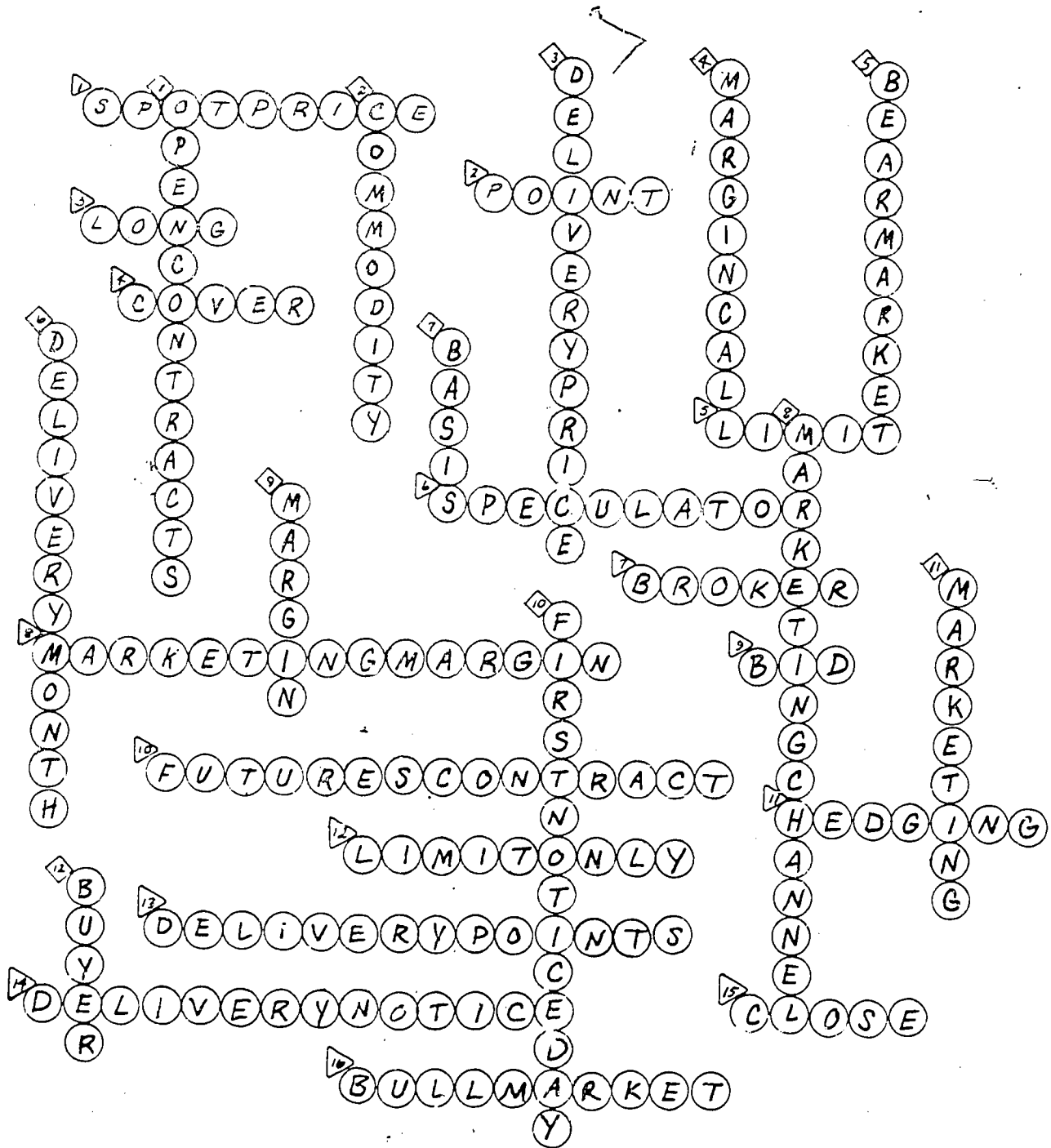

TEACHER'S KEY  
STUDENT WORKSHEET 12  
FUTURES BUBBLE PUZZLE  
(cont'd.)

ACROSS

1. The price at which a physical commodity is selling at a given time and place.
2. The minimum price fluctuation in futures. It is equal to 1/100 of one cent in most futures traded in decimal units. In grains, it is 1/8 of one cent.
3. One who has bought grain: also one who is on the buying side of an open (unhedged) futures contract.
4. The purchase of futures to offset a previously established short position.
5. The maximum price advance or decline from the previous day's settlement price permitted in one trading session by the rules of the exchange.
6. One who attempts to anticipate price changes and through market activities makes profits, and who is not hedging.
7. An agent entrusted with the execution of an order. This person may be employed in the office of the commission house that carries the account or a floor broker or pit broker who actually executes the order on the trading floor.
8. The difference between the amount consumers pay for the final product and the amount producers receive.
9. A price offered subject, unless otherwise stated, to immediate acceptance for a specific amount of commodity.
10. An agreement to buy and receive or sell and deliver a commodity at a future date with certain specified characteristics.

DOWN

1. Contracts which have been brought or sold without the transaction having been completed by subsequent sale or repurchase, or actual delivery or receipt of commodity.
2. Goods that can be bought and/or sold.
3. The price fixed by the Clearing House at which deliveries on futures are invoiced and also the price at which the futures contract is settled when deliveries are made.
4. A request to deposit either the original margin at the time of the transaction, or to restore the guarantee to "maintenance margin" levels required for the duration of the time the contract is held.
5. One where large supplies and/or poor demand cause a decline in price.
6. The calendar month during which a futures contract matures.
7. The spread or difference between the spot or "cash" price and the price of a specified futures delivery month price, or may also be used to designate price differentials between "cash" and more distant futures delivery months, as well as different locations as specified.
8. The route that a commodity takes on its way from the producer to the ultimate consumer.



## ACROSS

11. Is the sale of futures when holding the physical commodity or its equivalent, as protection against a price decline; or the purchase of futures against forward sales or anticipated requirements of the physical commodity, as protection against a price advance.
12. In trading, the definite price stated by a customer to a broker restricting the execution of an order to buy for not more than or to sell for not less than the stated price.
13. Those locations designated by commodity covered by a futures contract may be delivered in fulfillment of the contract.
14. The notification of delivery of the actual commodity on the contract, issued by the seller of the futures to the Clearing House.
15. The period at the end of the futures trading session during which all trades are officially declared as having been executed "at or on the close." The closing range is the range of prices on trades made during this designated period.
16. One where small supplies and/or strong demand causes prices to rise.

## DOWN

9. The amount deposited by buyers and sellers of futures, to insure performance on contracts commitments; serves as a performance bond rather than a "down-payment."
10. The first day on which notices of intentions to deliver actual commodities against futures market positions can be made or received. First notice day will vary with each commodity and exchange. It usually precedes the beginning of the delivery period.
11. All of the processes and services involved in moving a commodity from the producer to the ultimate consumer. The activity involved in buying or selling a product.
12. A purchaser of a commodity offered for sale or exchange.

\*Selected from National FFA Contests, Bulletin No. 4, 1982/1983/1984, pages 26-32, Kansas City, Missouri

---

# PRINCIPLE TYPES OF MARKETS

- Direct (Packing Plant)
- Terminal (Stockyards)
- Buying Station
- Auctions (Sale barn)
- Marketing Groups (NFO) (IPLA)

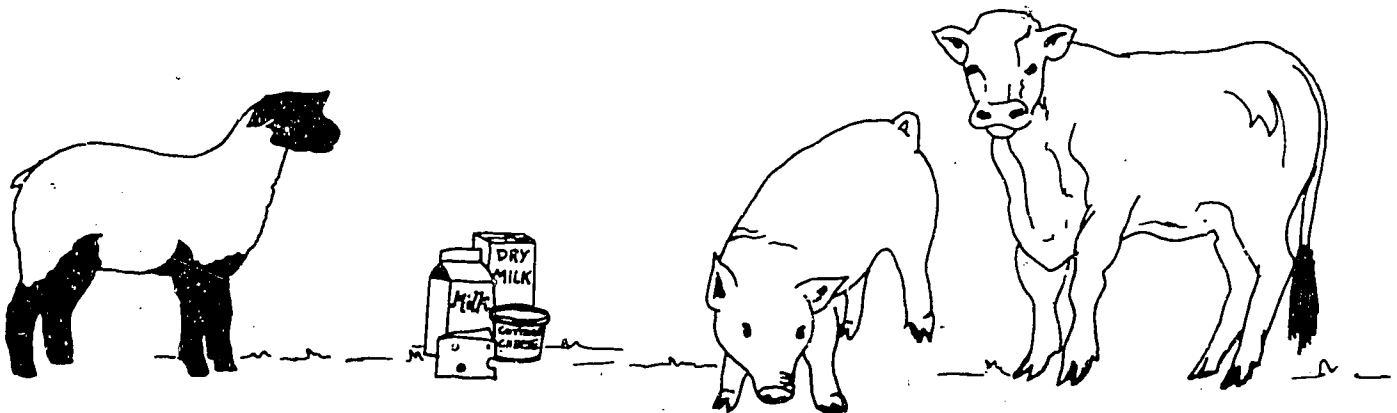

# MARKETING CHANNELS FOR LIVESTOCK

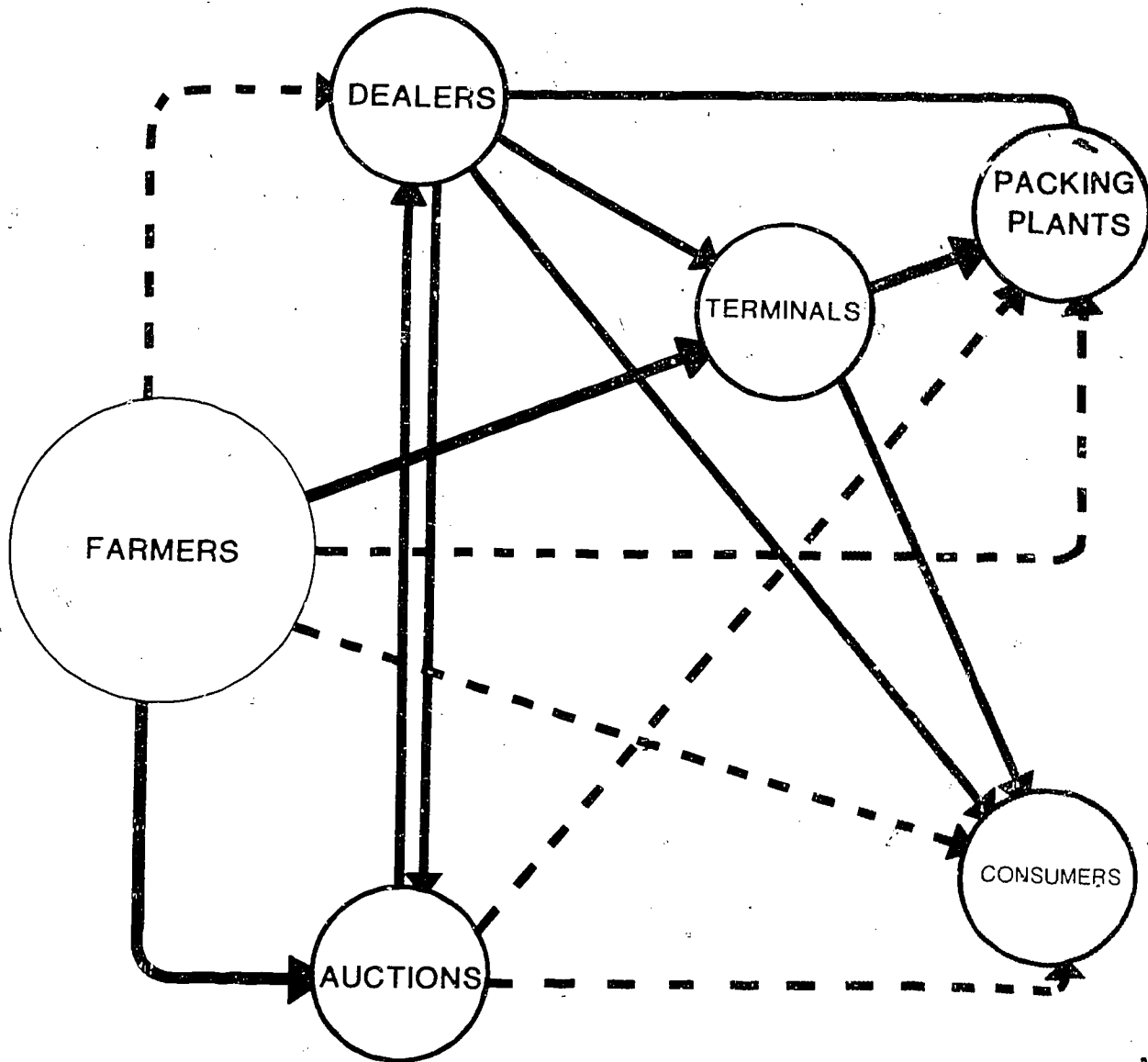

# RED MEAT DISTRIBUTION CHANNELS

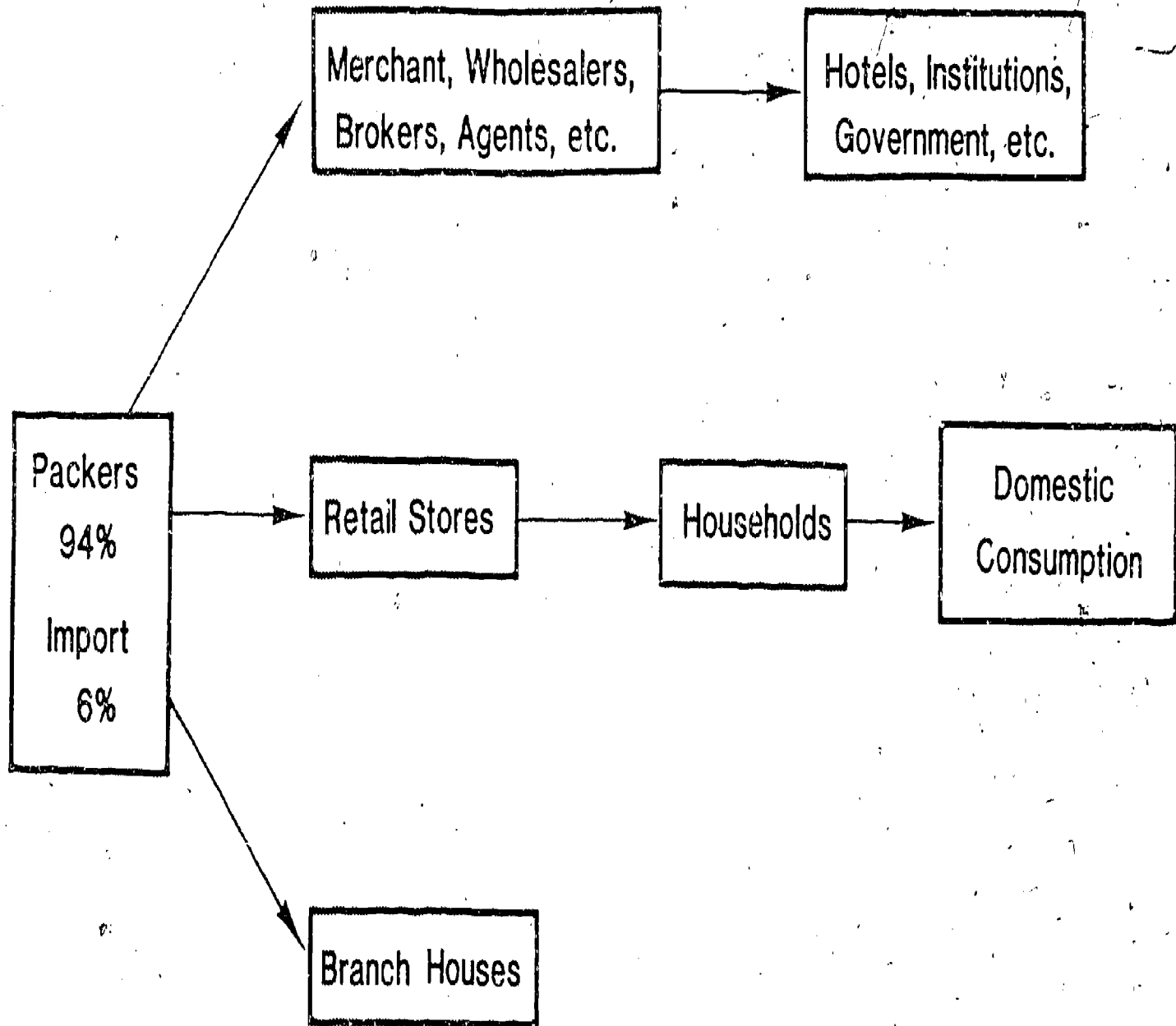

---

# HOW TO MINIMIZE SHRINKAGE WHEN MARKETING LIVESTOCK

## DO:

- THOROUGHLY PLAN THE SHIPMENT
- SELECT TRANSPORTATION BEST SUITED TO NEEDS AND CONDITIONS
- PLAN MOVEMENT DURING THE MOST DESIRABLE PART OF DAY
- CONDITION LIVESTOCK BEFORE SHIPPING (REDUCE THE AMOUNTS OF HIGH SHRINKAGE FEEDS AND INCREASE THE HAY OR ROUGHAGE)
- KEEP OFF OF FEED AND WATER FOR SEVERAL HOURS (NOT OVER 12 HOURS)
- BED VEHICLE PROPERLY
- PROTECT LIVESTOCK FROM WEATHER
- SORT HEIFERS AND STEERS (IF PRACTICAL)
- TAKE ADVANTAGE OF FEED, WATER AND REST STOPS DURING LONG JOURNEYS
- PROVIDE FOR FILLBACK AT MARKET IF CATTLE HAVE BEEN IN TRANSIT FOR MORE THAN 12 HOURS

---

# HOW TO MINIMIZE SHRINKAGE WHEN MARKETING LIVESTOCK

## DON'T:

- RUSH AND CROWD LIVESTOCK INTO CARS AND THROUGH GATES AND CHUTES
- USE CANES, CATTLE PRODS OR OTHER HARMFUL DEVICES WHILE LEADING CATTLE
- DELAY SHIPMENT AFTER CATTLE ARE READY FOR MOVEMENT
- OVERCROWD OR UNDERLOAD SHIPMENTS
- TRAIL CATTLE GREAT DISTANCES UNLESS THERE IS ADEQUATE FEED AND WATER AVAILABLE
- OVERFILL LIVESTOCK AT DESTINATION
- LEAVE LIVESTOCK IN AUCTIONS WITHOUT SPECIAL ATTENTION

---

# CAUSES OF CATTLE BRUISES

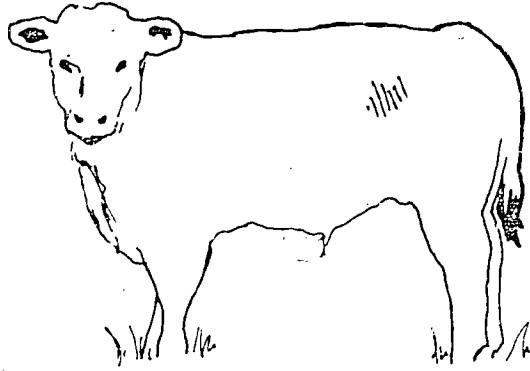

## CAUSES

## PERCENT

A. Crowding, Bumping, Rushing

66%

B. Trampling

C. Canes, Whips, Electrical cattle prods

D. Horned cattle

E. Other causes

34%

492

---

# CAUSES OF BRUISES ON HOGS

IMPACT INJURIES 62%

canes, whips, clubs,  
kicking, prodding

PUNCTURES & OTHER  
INJURIES 38%

nails, pitchforks, loose  
boards on fencing



---

# CHECK POINTS for SAFE TRUCKING

- Proper ventilation
- No broken boards
- Proper overhead clearance
- No protruding nails
- Wide doors
- Upper deck high enough for clearance
- Adequate partitions for different livestock or large herd transportation

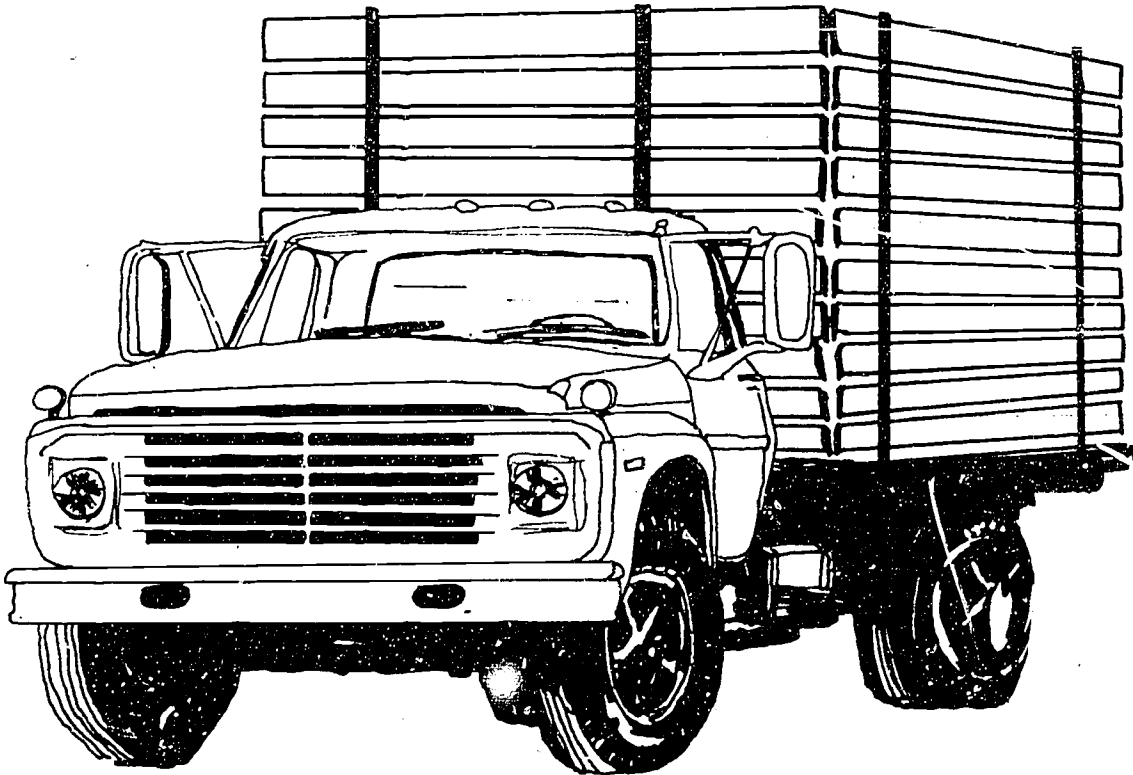

III-1-3-54

49-

TEACHER'S KEY

SAMPLE TEST QUESTIONS

MARKETING LIVESTOCK AND LIVESTOCK PRODUCTS

I. Matching

Directions: Match the terms in Column A to the definitions in Column B.

Column A

- F 1. spot price
- H 2. long
- C 3. speculator
- D 4. hedging
- E 5. futures contract
- G 6. margin
- J 7. open contract
- I 8. delivery points
- A 9. bull market
- B 10. margin call

Column B

- A. One where small supplies and/or strong demand causes prices to rise.
- B. A request to deposit either the original margin at the time of the transaction, or to restore the guarantee to "maintenance margin" levels required for the duration of the time the contract is held.
- C. One who attempts to anticipate price changes and through market activities makes profits, and who is not hedging.
- D. Is the sale of futures when holding the physical commodity or its equivalent, as protection against a price decline; or the purchase of futures against forward sales or anticipated requirements of the physical commodity, as protection against a price advance.
- E. An agreement to buy and receive or to sell and deliver a commodity at a future date with certain specified characteristics.
- F. The price at which a physical commodity is selling at a given time and place.
- G. The amount deposited by buyers and sellers of futures, to insure performance on contracts commitments; serves as a performance bond rather than a "down-payment."
- H. One who has bought grain: also one who is on the buying side of an open (unhedged) futures contract.
- I. Those locations designated by commodity exchanges at which a commodity covered by a futures contract may be delivered in fulfillment of the contract.

Column B

J. Contracts which have been brought or sold without the transaction having been completed by subsequent sale or repurchase, or actual delivery or receipt of commodity.

II. Matching

Column A

- C 11. dealer
- D 12. supply
- H 13. order buyer
- I 14. auction
- E 15. direct
- B 16. commission
- F 17. cooperative market
- H 18. order buyer
- A 19. packer market
- G 20. contract selling

Column B

- A. A facility operated privately and solely by a packer or slaughterer where livestock is purchased directly from the producer for slaughter.
- B. A fee or a charge paid by the seller to an agent for selling services; or a fee charge paid by the purchaser to an agent for the buying of cattle.
- C. An individual, not a market agency, engaged in the business of buying or selling livestock for his own account, usually on a speculative basis.
- D. The quantity of a product that is placed on the market at any given time.
- E. The transfer of ownership of livestock from the seller to the purchaser without the service of an agency.
- F. A method of selling livestock in which the service is performed by, or on behalf of, a voluntary association of livestock producers.
- G. The agreement between an owner and a buyer on the price of livestock setting forth the provisions relating to the description, delivery date, weighing point, and delivery point prior to the delivery of the livestock.
- H. A term applied to an individual who purchases livestock for others.
- I. A market on which livestock are displayed in a ring and offered for sale to all buyers to the highest bidder.

III. Short Answer:

21. Name five do's and don'ts for keeping shrinkage to a minimum.

Do:

- a. thoroughly plan the shipment
- b. select transportation best suited to needs and conditions
- c. plan movement during the most desirable part of day
- d. condition livestock before shipping (reduce the amounts of high shrinkage feeds and increase the hay or roughage)
- e. keep off of feed and water for several hours (not over 12 hours)
- f. bed vehicle properly
- g. protect livestock from weather
- h. sort heifers and steers (if practical)
- i. take advantage of feed, water and rest stops during long journeys
- j. provide for fillback at market if cattle have been in transit for more than 12 hours

Don't:

- a. rush and crowd livestock into cars and through gates and chutes
- b. use canes, cattle prods or other harmful devices while leading cattle
- c. delay shipment after cattle are ready for movement
- d. overcrowd or underload shipments
- e. trail cattle great distances unless there is adequate feed and water available
- f. overfill livestock at destination
- g. leave livestock in auctions without special attention

22. List four principle types of livestock and livestock products markets:

- a. direct (packing plants)
- b. terminal (stockyards)
- c. buying station
- d. auctions (sale barns)
- e. marketing groups (NFO, IPLA)

23. What are four of the seven checkpoints for safe trucking?

- a. proper ventilation
- b. no broken boards
- c. proper overhead clearance
- d. no protruding nails
- e. wide doors
- f. upperdeck high enough for clearance
- g. adequate partitions for different livestock or large herd transportation

24. Which of the following contributes to the number one cause of cattle bruises? Circle your answer.
- a. Horned cattle
  - b. Trampling
  - c. Other causes
  - d. Crowding, bumping, and rushing
25. Name two main factors that cause livestock prices to fluctuate.
- a. Supply
  - b. Demand

#### IV. Marketing Problems

Work the following problems and be sure to show your calculations.

26. You sold 5 steers which averaged 450 lbs. live weight. They brought \$37.50 per hundred weight, and you gave a 3% shrinkage. How much money did you receive for your steers?

$$(450) \times (.03) = 13.5\#$$

$$450 - 13.5 = 436.50\#$$

$$(436.50\#) \times (.3750) = (163.69) \times (5) = \$818.44$$

27. You sold 3 market barrows according to yield and grade. The barrows averaged 230 lbs. live weight, and the carcass averaged 165 lbs. What is the percent yield?

$$165 \div 230 = 72\%$$

28. You sold a 980 lb. Hereford steer which hung up a 560 lbs. carcass. What was the percent yield of the steer?

$$\frac{560}{980} \times 100 = 57 \text{ percent yield}$$

29. Ten steers sold for \$60.50 per hundred weight. They averaged 1100 lbs. at home and you agreed on a 2% pencil shrink. What was the amount of money you received?

$$1100 \times .02 = 22.00\#$$

$$1100 - 22 = 1078\#$$

$$(1078\#) \times (.6050) \times (10) = \$6521.90$$

30. You sold five Angus steers at a local sale barn. The steers average live weight was 975 pounds. Using a price of \$50.50 per hundred weight, what would the steers value be?

$$(5) \times (975) \times (.5050) = \$2461.88$$