

**KAORI**



KAORI Brazed Plate Heat Exchanger  
**Application for  
Refrigerated Air Dryer and Air Compressors**



ASME  
Certified



KHK  
Japan

KRAIA  
Korea

CRN  
Certified

[www.kaori-bphe.com](http://www.kaori-bphe.com)

High Quality from Taiwan





**Innovation · Quality · Responsibility · Honor**



# Index

Company Profile .....	2
KAORI History .....	3
High Efficiency 3-In-1 Heat Exchanger for Refrigerated Air Dryer (A Series) .....	4
The Working Principle of a 3-In-1 Heat Exchanger.....	5
Guides to Kaori's A Series Brazed Plate Heat Exchangers.....	6
Patents .....	7
A series Standard BPHE .....	8
A series High Pressure BPHE .....	9
A series Eco-Type BPHE.....	10
T Type-A Series Chilled Outlet Air BPHE .....	11
G Type-A Series High-Pressure Refrigerant BPHE .....	12
D Type-A Series Desiccant/Refrigerated Combination BPHE.....	13
R Type-A Series Refrigerant Heat Recovery BPHE .....	15
KAORI A series Compared with Other 3-In-1 Heat Exchangers.....	16
KAORI A Series Compared with Shell & Tube Heat Exchangers.....	17
KAORI A Series Compared with Other 2-In-1 Heat Exchangers .....	18
Air Compressor Heat Recovery System BPHE (K200).....	19
Air Compressor Double Heat Recovery System Selection Table (Air + Oil) .....	20
Oil Cooler/ After Cooler Application for Air Compressor .....	21
Appendix - Air Dryer Selection Table.....	22

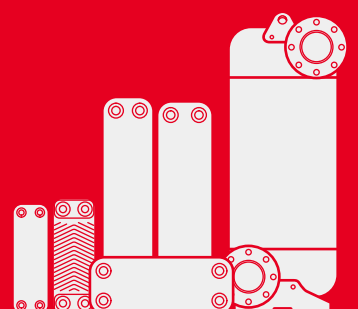

## Company Profile

KAORI was established in 1970, insisting on pursuing innovative technology and manufacturing world-class products as its main goal. Consistently improving, researching, and importing new technology, KAORI launched the brazed plate heat exchanger division in 1994, and the quality system was ISO9001 certified in 1995. Afterwards, KAORI brazed plate heat exchanger obtained numerous patents and certificates. In order to fulfill the increasing demand from the worldwide market, Kaohsiung plant and Ningbo plant were built in 2002 and 2005 to provide larger production capacity. KAORI brazed plate heat exchanger is the No.1 brand in Taiwan and has been exported to more than 50 countries.



Chungli Taiwan Plant



Kaohsiung Taiwan Plant



Ningbo China Plant

## Facility and Test Equipment



Vacuum Furnace



Continuous Pressing

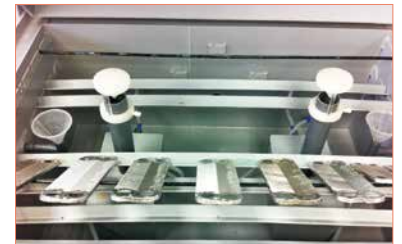

Salt Spray Test



CO<sub>2</sub> High Pressure Test



Helium Leakage Test



Thermal Shock Tester



Performance Test



Pressure Leakage Test



Burst Test

# KAORI History

- 1970** KAORI Heat Treatment Co., Ltd. was established in Taipei, Taiwan.
- 1994** KAORI founded the brazed plate heat exchanger department.
- 2001** KAORI's second brazed plate heat exchanger manufacturing plant was established in Kaohsiung, Taiwan.
- 2004** KAORI's third brazed plate heat exchanger manufacturing plant was established in Ningbo, China.
- 2006** KAORI became a share holding company in Taiwan's stock exchange.
- 2006** KAORI launched several new BPHE for refrigerated air dryer - A070,A210.
- 2011** KAORI Heat Exchange Japanese branch office was established.
- 2014** KAORI launched several new BPHE product- A030 in Chillventa Expo.
- 2015** KAORI launched the new product - Double wall D070 model.
- 2016** KAORI launched several new BPHE for refrigerated air dryer - A140.
- 2017** KAORI launched the high-pressure 3-in-1 refrigerated air dryer heat exchanger - A032, A072
- 2019** ISO14001 Certified
- 2020** KAORI launched the high-pressure 3-in-1 refrigerated air dryer heat exchanger - A033, A073

# KAORI Milestone

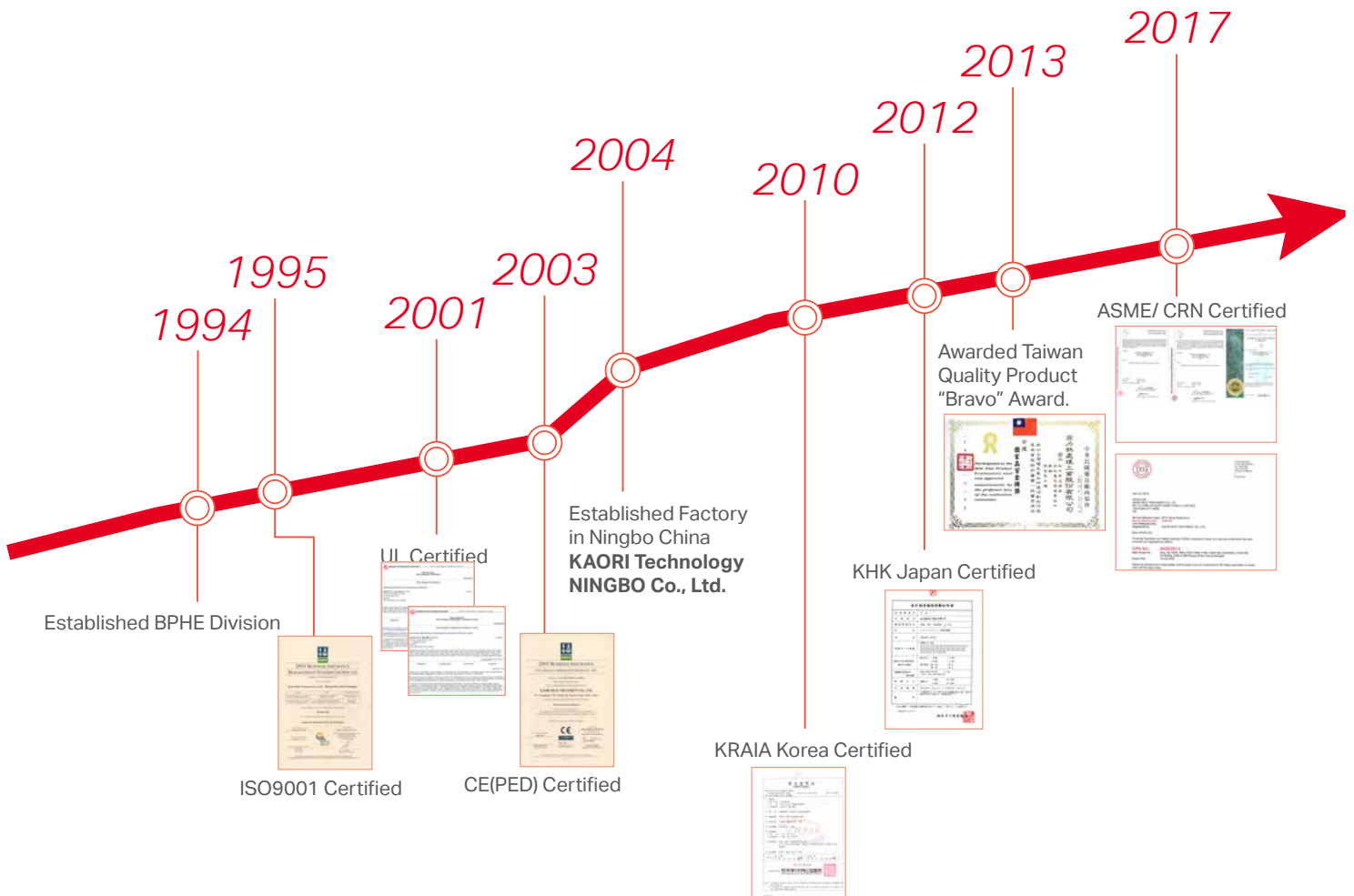

## High Efficiency 3-In-1 Heat Exchanger for Refrigerated Air Dryer (A Series)

**3**  
**Years**  
**Warranty**



**No Mesh,  
No Clogging  
Problems**

**Working  
Pressure  
Up to  
45bar**

**PATENTS**  
**Equipped  
With Patented  
Leakage Testing  
Connector**



### Size Reduced by 50%

With high heat transfer area design, heat exchanger size can be reduced by 50% compared to others.



### Most Complete Models Capacity Up to 200HP

Most complete models, KAORI's 3-in-1 heat exchanger has the capacity from 5 HP to 200 HP.



### Stainless Steel, Anti-corrosion

Patented plate design of evaporator, shorten the flow path of refrigerant by 30%, with the smooth surface of SUS 304, KAORI can prevent lubricant oil residual which happens frequently in aluminum plate fin heat exchangers.

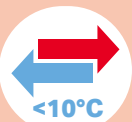

### Inlet/Outlet Temp. Difference < 10°C

With high efficiency heat recovery from the inlet and treated outlet air, capacity of refrigerant compressor can be smaller, and the treated outlet air could be used directly.

# The Working Principle of a 3-In-1 Heat Exchanger

## 3-in-1 heat exchanger - include evaporator, Separator, pre-cooler/heater

Air compressor compresses hot and moist air to the pre-cooler of a 3-in-1 heat exchanger, then the hot & moist air exchanges heat with treated cold air. This chilled moist air enters the evaporator, lower down temperature and condensate water out by evaporation. After, the air moves to the separator, with centrifugal force and gravity, the condensate water can be separated from air. Finally, the cool & dry air goes back to preheater to be heated to the working temperature.

- **Evaporator:**  $\Phi$ 
  - Condense out moisture from air through our high efficiency heat exchanger.
  - High efficiency, low dew point, and low pressure drop.
- **Separator:**
  - Centrifugal force and gravity separate moistures from air.
  - No mesh designed, clogging free, easy to maintain.
- **Pre-cooler/ heater:**
  - Save energy by exchanging heat from inlet and outlet air temperature.
  - Outlet air can be used directly. It is preheated to the working temperature.

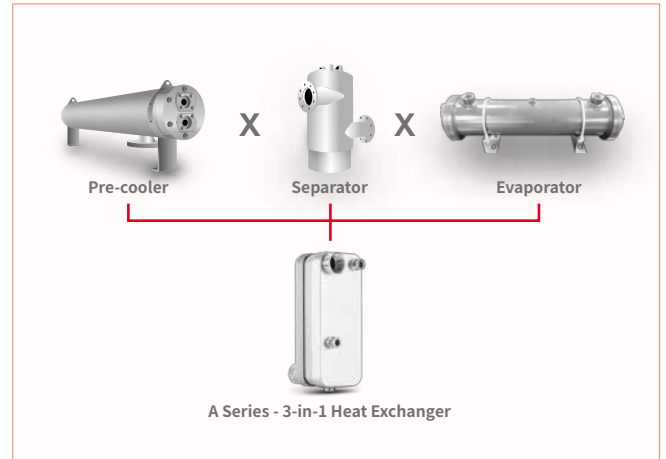

## System Diagram of 3-in-1 Heat Exchanger for Refrigerated Air Dryer

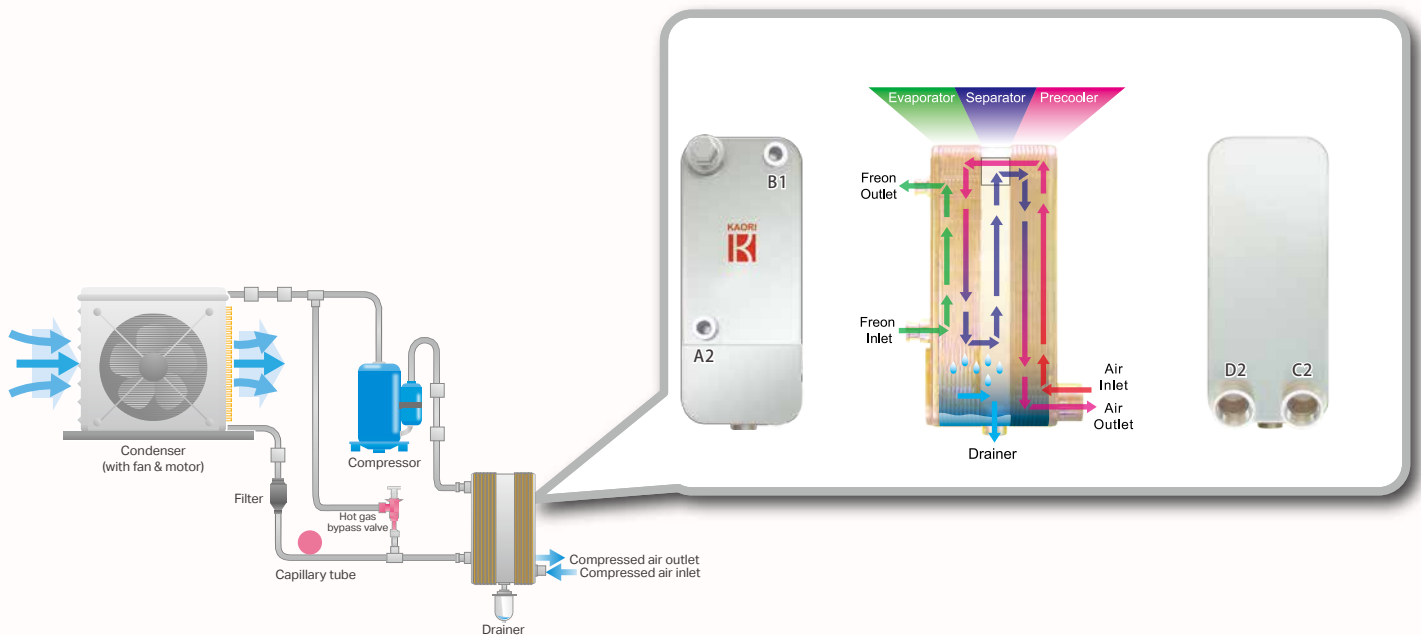



# Guides to Kaori's A Series Brazed Plate Heat Exchangers

## A Series Model and Product Code Illustrations

**A070-20-26A-G**

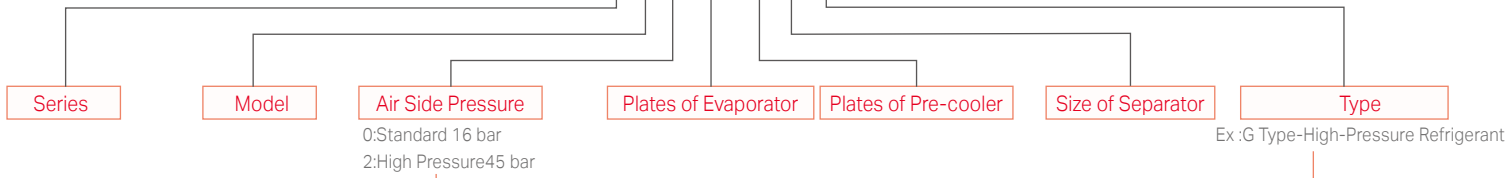

Types	Standard	High-Pressure Air Type	Eco Type	T Type Chilled Outlet Air	G Type High-Pressure Refrigerant	D Type Desiccant/Refrigerated Combination	R Type Refrigerant Heat Recovery
Characteristic	Standard 3-in-1 Heat Exchangers	Suitable for High-pressure Air up to 45 Bar	Suitable smaller air dryer applications up to 16 Bar	Chilled Dry Compressed Air 2-in-1 Heat Exchanger	Suitable for High-pressure Refrigerant up to 45 Bar	For Combined Dryers Systems Downsized by 50%	Heat-pump-integrated Refrigerated Air Dryers of Energy Conservations
Applications	Refrigerated Air Dryers	PET, Blowing Molding, Pharmaceutical Packaging, and Injection Molding Machines	Medical, Textile, Semiconductor and Electronics, Chemical, Machinery	Semiconductor Related Manufacturing, Food Processing, Coating, Air Bearing, and Injection Molding Machines	For Refrigerated Air Dryer Applications under High Ambient Temperature	Semiconductor and Precision Manufacturing Related Industries	Machines with Compact Compressed Air Temperature Control Equipments
Connectors	Stainless Steel SUS 304						
Plates, Separators	Stainless Steel SUS 304						
Welding materials	99.9% Copper						
A030	●	●	●	●	●	●	●
A070	●	●	●	●	●	●	●
A140	●			●	●		
A210	●				●	●	

## Standard A Series Connectors

Model	Thread Connectors PT/ NPT/ GB							Solder Connectors							Height (mm)	
	1/2"	3/4"	1"	1 1/4"	1 1/2"	2"	2 1/2"	3"	Φ9.73mm	Φ12.9mm	Φ16.15mm	Φ19.25mm	Φ22.36mm	Φ25.6mm		Φ28.8mm
A030	◎	◎							◎	○						15
A070		○	◎	◎					◎	◎	○	○				27
A140				◎	◎					◎	◎	◎	○	○	○	27
A210					○	◎	◎	◎		○	◎	◎	◎	○	○	27

◎ : Standard Connector ○ : Available Connector



UL

CE/PED



# Patents

**2006**

Acquired Patent of "**Heat Exchanger Having Air Drying Device**" – Patent 3-in-1 heat exchanger. Reducing size, increase efficiency.



China



Japan



Taiwan



Korea



USA

**2013**

Acquire "**Air Side Leak Test**" Patent – Industry leading. Ensure 100% high quality.



Japan



Germany

**2013**

Acquire "**Air Dryer Heat Exchanger Having Oil Return Device**" Patent- Designed oil return hole, compressors without losing oil.



Taiwan



Japan



Germany

**2017**

Acquire "**Combined Dryer Device**" Patent - the multi-functional 3-in-1 design that cascades desiccant and refrigerated dryer applications.



Taiwan



Germany

# A series Standard BPHE

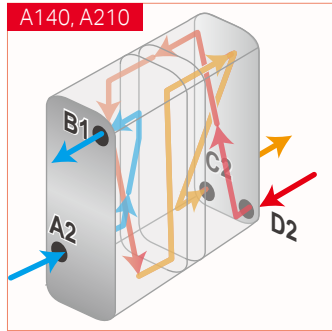
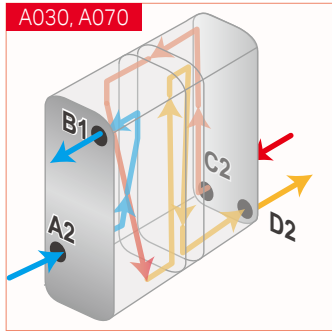
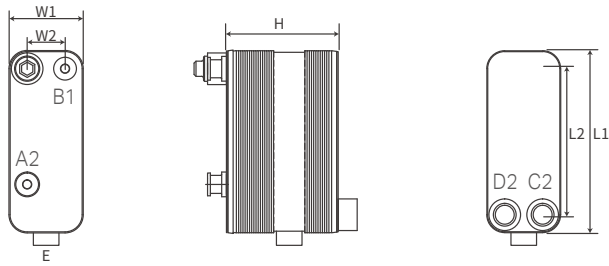

Specification					
Model	A030	A070	A140	A210	
MAX. Working Temperature	200°C				
L1 (mm)	192	304	441	527	
L2 (mm)	154	250	360	430	
W1 (mm)	78	124	206	245	
W2 (mm)	40	70	125	148	
Max Working Pressure (bar)	Air Side	16	16	16	10
	Ref. Side	30	30	30	30
Air Inlet	C2		D2		
Air Outlet	D2		C2		
Ref. In	A2				
Ref. Out	B1				
Drainer	E				

A series is KAORI's innovative patent design for refrigerated air dryer. Combining pre-cooler, evaporator and separator. A series provides compact size and high thermal transfer performance for your system. The patented design separator can perfectly dehumidify compressed air and eliminate the need for demister to avoid clogging problem

## A Series Standard BPHE Model Selection Chart

Air Compressor Power	Air Flow Rate @ 7barG			Model	Length	Width	Height	Weight	Separator Height	Ref. Side Connector	Air Side Connector	Drainer	Compressor Power	Pressure
	HP	Nm³/min	Nm³/hr											
5	0.58	35	21	<b>A030-14-8A</b>	192	78	99	2.8	44	S3	3/4	1/2	1/4	≅ 20
8	0.83	50	29	<b>A030-20-10A</b>	192	78	117	3.1	44	S3	3/4	1/2	1/4	
10	1.00	60	35	<b>A030-22-12A</b>	192	78	126	3.3	44	S3	3/4	1/2	1/4	
12	1.33	80	47	<b>A030-24-16A</b>	192	78	139	3.6	44	S3	3/4	1/2	1/2	
15	1.67	100	59	<b>A030-40-24A</b>	192	78	194	4.6	44	S3	3/4	1/2	1/2	
20	2.40	144	85	<b>A070-20-26A</b>	304	124	156	10.7	45	S4	1	1/2	1	
30	4.20	252	148	<b>A070-32-40B</b>	304	124	229	13.9	60	S4	1-1/4	1/2	1	
50	7.00	420	247	<b>A070-46-66C</b>	304	124	348	19.8	90	S4	1-1/2	1/2	1.5	
75	11.00	660	388	<b>A140-24-36A</b>	441	206	224	30.8	79	S5	2	1/2	2	
100	14.00	840	494	<b>A140-32-44B</b>	441	206	280	36.4	99	S5	2	1/2	3	
150	22.00	1320	777	<b>A210-40-50C</b>	527	245	394	78.2	166	S7	2-1/2	1/2	4	
200	28.00	1680	989	<b>A210-50-64D</b>	527	245	501	96.3	216	S9	3	1/2	5	

\* Connectors and stub bolts can be customized. Please contact KAORI for further information.

# A series High Pressure BPHE

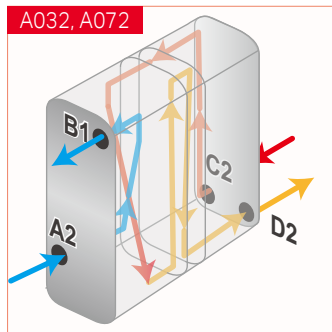
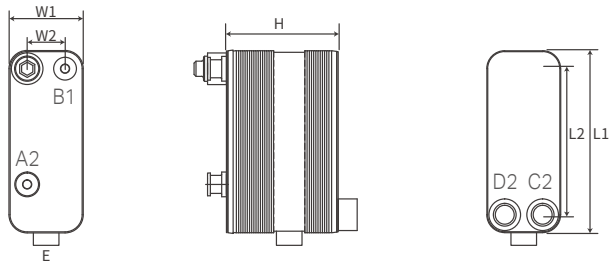

Specification			
Model	A032	A072	
MAX. Working Temperature	200°C		
L1 (mm)	192	304	
L2 (mm)	154	250	
W1 (mm)	78	124	
W2 (mm)	40	70	
Max Working Pressure (bar)	Air Side	45	45
	Ref. Side	30	30
Air Inlet	C2		
Air Outlet	D2		
Ref. In	A2		
Ref. Out	B1		
Drainer	E		

## KAORI's High Pressure Air Dryer Series are available in operating up to 45 bar (653 PSI).

The best component for high pressure refrigerated air dryer, it is combined with a pre-cooler/ heater, separator, and an evaporator, eliminating water vapor from high pressure compressed air with dew points from 3°C to 10°C.

With reliable stainless steel and optimized efficiency design, KAORI Air Dryer Series have the advantages of size reducing, clogging free, easy to maintain, and anti-corrosion, providing perfect solutions for refrigerated air dryers applying in PET blow molding, pharmaceutical packaging, injection molding and other applications that require high pressure heat exchangers.

## A Series High Pressure BPHE Model Selection Chart

Air Flow Rate @ 40barG			Model	Length	Width	Height	Weight	Separator Height	Ref. Side Connector	Air Side Connector	Drainer	Compressor Power	Pressure
Nm³/min	Nm³/hr	SCFM											
1.0	100	35	<b>A032-14-8A</b>	192	78	102	3.70	44	S3	3/4	1/2	1/4	≤ 20
2.0	150	71	<b>A032-22-12A</b>	192	78	128	4.20	44	S3	3/4	1/2	1/4	
3.0	250	106	<b>A032-26-18A</b>	192	78	150	4.65	44	S3	3/4	1/2	1/4	
6.0	500	212	<b>A072-28-30A</b>	304	124	182	13.58	45	S4	1-1/4	1/2	1/2	
10.0	800	353	<b>A072-40-46A</b>	304	124	245	16.50	45	S4	1-1/4	1/2	1/2	
15.0	900	530	<b>A072-50-64A</b>	304	124	307	19.42	45	S4	1-1/2	1/2	1	
20.0	1200	707	<b>A072-60-70A</b>	304	124	343	21.08	45	S4	1-1/2	1/2	1	

\* Connectors and stub bolts can be customized. Please contact KAORI for further information.

## A series Eco-Type BPHE

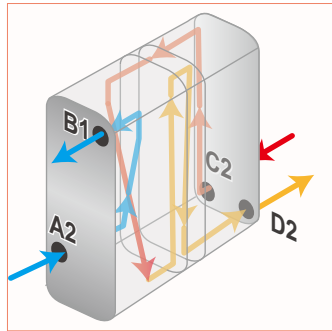
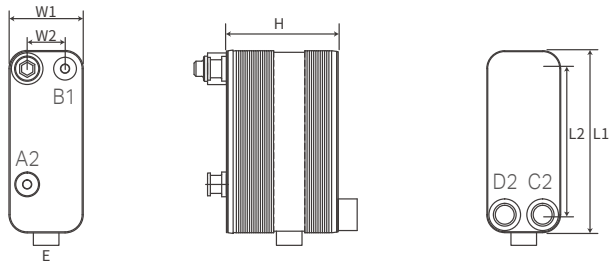

Specification			
Model	A033	A073	
MAX. Working Temperature	200°C		
L1 (mm)	194	308	
L2 (mm)	154	250	
W1 (mm)	80	128	
W2 (mm)	40	70	
Max Working Pressure (bar)	Air Side	16	16
	Ref. Side	30	30
Air Inlet	C2		
Air Outlet	D2		
Ref. In	A2		
Ref. Out	B1		
Drainer	E		

Kaori's Eco Type A Series is mainly designed for smaller air dryer applications under 7m<sup>3</sup>/min. It is made with SUS304 chevron plates and high purity copper foil. This allows the advantages of compactness, high heat transfer efficiency, and high corrosion resistance. Also integrated with patented structure design, combining air precooler, water separator and evaporator together in one. Reaching low pressure drop stable dew point, precooling and making it an ideal heat exchangers for air dryer applications.

### A Series Standard BPHE Model Selection Chart

Air Compressor Power	Air Flow Rate @ 7barG			Model	Length	Width	Height	Weight	Separator Height	Ref. Side Connector	Air Side Connector	Drainer	Compressor Power	Pressure
	HP	Nm <sup>3</sup> /min	Nm <sup>3</sup> /hr											
5	0.58	35	21	<b>A033-13-8A</b>	194	80	94	2.8	44	S3	3/4	1/2	1/4	≅ 20
10	1.00	60	35	<b>A033-23-14A</b>	194	80	126	3.4	44	S3	3/4	1/2	1/4	
15	1.67	100	59	<b>A033-39-24A</b>	194	80	194	4.5	44	S3	3/4	1/2	1/2	
20	2.40	144	85	<b>A073-19-24A</b>	308	128	147	10.6	45	S4	3/4	1/2	1	
25	2.83	170	100	<b>A073-21-28A</b>	308	128	160	11.1	45	S4	1	1/2	1	
30	4.20	252	148	<b>A073-31-40B</b>	308	128	224	14.1	60	S4	1	1/2	1	
40	5.66	340	200	<b>A073-37-54C</b>	308	128	299	17.7	90	S4	1-1/4	1/2	1	
50	7.00	420	247	<b>A073-45-66C</b>	308	128	343	19.8	90	S4	1-1/4	1/2	1.5	

\* Connectors and stub bolts can be customized. Please contact KAORI for further information.



## T Type-A Series Chilled Outlet Air BPHE

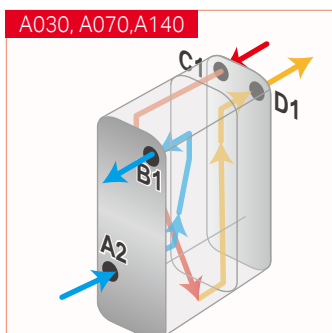
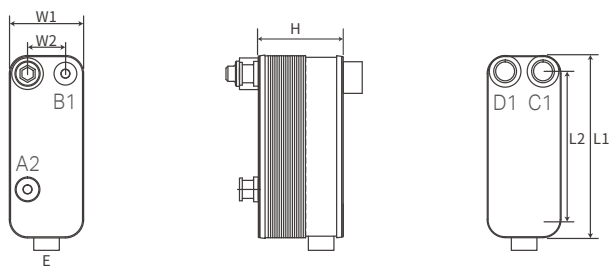

Specification				
Model	A030	A070	A140	
MAX. Working Temperature	200°C			
L1 (mm)	192	304	441	
L2 (mm)	154	250	360	
W1 (mm)	78	124	206	
W2 (mm)	40	70	125	
Max Working Pressure (bar)	Air Side	16	16	16
	Ref. Side	30	30	30
Air Inlet			C1	
Air Outlet			D1	
Ref. In			A2	
Ref. Out			B1	
Drainer			E	

Chilled outlet air dryers are designed for dry and chilled compressed air in certain manufacturing processes, and the outlet air temperature can be close to the dew point temperature. The chilled outlet air T type A series heat exchangers are designed for chilled and dry compressed air. A unique 2-in-1 design consisting of an evaporator and a gas-water separator allows adjustable dew point temperatures as low as 3 °C. Air flow ranges from 0.3 m<sup>3</sup>/min to 14 m<sup>3</sup>/min. The gas-water separator employs no internal filter, and is free of clogging.

### T Type-A Series Chilled Outlet Air BPHE Model Selection Chart

Air Compressor Power	Air Flow Rate @ 7barG			Model	Length	Width	Height	Weight	Separator Height	Ref. Side Connector	Air Side Connector	Drainer	Compressor Power	Pressure
	HP	Nm <sup>3</sup> /min	Nm <sup>3</sup> /hr											
5	0.58	35	21	<b>A030-28A-T</b>	192	78	112	3	44	S3	3/4	1/2	1/4	≅ 20
10	1.00	60	35	<b>A030-44A-T</b>	192	78	148	4	44	S3	3/4	1/2	1/4	
15	1.67	100	59	<b>A030-80A-T</b>	192	78	230	6	44	S3	3/4	1/2	1/2	
20	2.40	144	85	<b>A070-40A-T</b>	304	124	144	11	45	S4	1	1/2	1	
30	4.20	252	148	<b>A070-64B-T</b>	304	124	212	14	60	S4	1-1/4	1/2	1	
50	7.00	420	247	<b>A070-92C-T</b>	304	124	304	18	90	S4	1-1/2	1/2	1.5	
75	11.00	660	388	<b>A140-48A-T</b>	441	206	199	28	79	S5	2	1/2	2	
100	14.00	840	494	<b>A140-64B-T</b>	441	206	256	34	99	S5	2	1/2	3	

\* Connectors and stub bolts can be customized. Please contact KAORI for further information.

## G Type-A Series High-Pressure Refrigerant BPHE

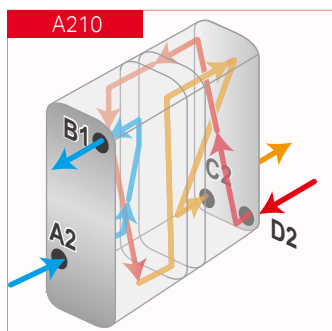
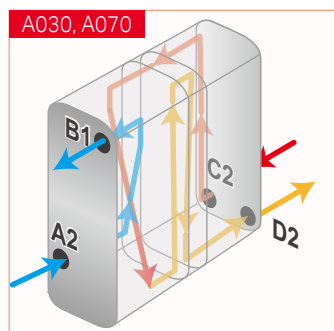
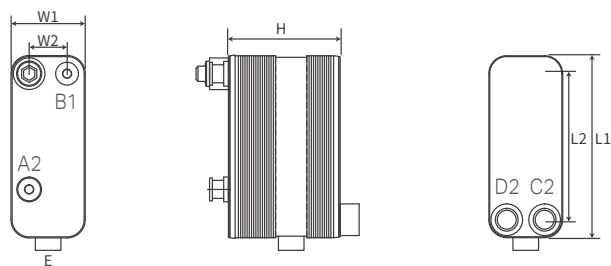

Specification				
Model	A030	A070	A210	
MAX. Working Temperature	200°C			
L1 (mm)	192	304	527	
L2 (mm)	154	250	430	
W1 (mm)	78	124	245	
W2 (mm)	40	70	148	
Max Working Pressure (bar)	Air Side	16	16	10
	Ref. Side	45	45	45
Air Inlet	C2		D2	
Air Outlet	D2		C2	
Ref. In	A2			
Ref. Out	B1			
Drainer	E			

The high-pressure refrigerant G type air dryer plate heat exchanger is specifically designed for systems with a pressure requirement of 45 bar for refrigerant. The refrigerant side allows a maximum working pressure up to 45bar, which is suitable for R410A, and high ambient temperature environments.

### G Type-A Series High-Pressure Refrigerant BPHE Model Selection Chart

Air Compressor Power HP	Air Flow Rate @ 7barG			Model	Length mm	Width mm	Height mm	Weight kg	Separator Height mm	Ref. Side Connector	Air Side Connector	Drainer	Compressor Power HP	Pressure kPa
	Nm³/min	Nm³/hr	SCFM											
5	0.58	35	21	<b>A030-14-8A-G</b>	192	78	99	2.8	44	S3	3/4	1/2	1/4	≅ 20
8	0.83	50	29	<b>A030-20-10A-G</b>	192	78	117	3.1	44	S3	3/4	1/2	1/4	
10	1.00	60	35	<b>A030-22-12A-G</b>	192	78	126	3.3	44	S3	3/4	1/2	1/4	
12	1.33	80	47	<b>A030-24-16A-G</b>	192	78	139	3.6	44	S3	3/4	1/2	1/2	
15	1.67	100	59	<b>A030-40-24A-G</b>	192	78	194	4.6	44	S3	3/4	1/2	1/2	
20	2.40	144	85	<b>A070-20-26A-G</b>	304	124	156	10.7	45	S4	1	1/2	1	
30	4.20	252	148	<b>A070-32-40B-G</b>	304	124	229	13.9	60	S4	1-1/4	1/2	1	
150	22.00	1320	777	<b>A210-40-50C-G</b>	527	245	394	78.2	166	S7	2-1/2	1/2	4	
200	28.00	1680	989	<b>A210-50-64D-G</b>	527	245	501	96.3	216	S9	3	1/2	5	

\* Connectors and stub bolts can be customized. Please contact KAORI for further information.

# D Type-A Series Desiccant/Refrigerated Combination BPHE

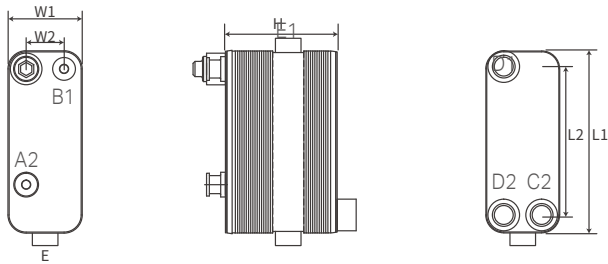

Specification				
Model	A070	A140	A210	
MAX. Working Temperature	200°C			
L1 (mm)	304	441	527	
L2 (mm)	250	360	430	
W1 (mm)	124	206	245	
W2 (mm)	70	125	148	
Max Working Pressure (bar)	Air Side	16	16	10
	Ref. Side	30	30	30
Air Inlet	C2	D2		
Before-desiccant Air Outlet	E1			
After-desiccant Air Inlet	D1			
Processed Air Outlet	D2	C2		
Ref. In	A2			
Ref. Out	B1			
Drainer	E			

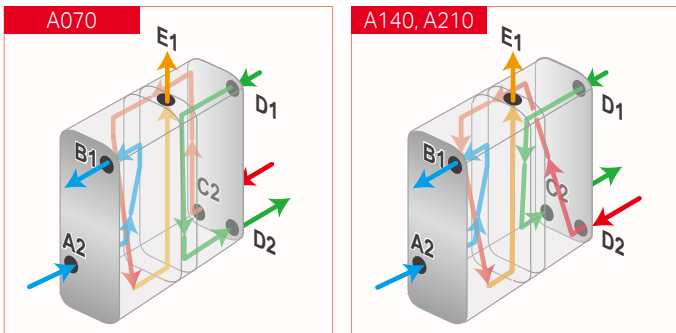

For the application using cascading refrigerated and desiccant dryers, Kaori's D Type adopts a new flow path design that directs the chilled dry air from the gas-water separator into the desiccant dryer for deep dehumidifications. After reaching the dew point temperature of  $-40\sim-70\text{ }^{\circ}\text{C}$ , the air then returns to the D Type for use after preheating.

## D Type-A Series Desiccant/Refrigerated Combination BPHE Model Selection Chart

Air Compressor Power	Air Flow Rate @ 7barG			Model	Length	Width	Height	Weight	Separator Height	Ref. Side Connector	Air Side Connector	Drainer	Compressor Power	Pressure
	HP	Nm <sup>3</sup> /min	Nm <sup>3</sup> /hr											
30	4.20	252	148	<b>A070-32-40B-D</b>	304	124	229	13.9	60	S4	1-1/4	1/2	1	≒ 20
50	7.00	420	247	<b>A070-46-66C-D</b>	304	124	348	19.8	90	S4	1-1/2	1/2	1.5	
75	11.00	660	388	<b>A140-24-36A-D</b>	441	206	224	30.8	79	S5	2	1/2	2	
100	14.00	840	494	<b>A140-32-44B-D</b>	441	206	280	36.4	99	S5	2	1/2	3	
150	22.00	1320	777	<b>A210-40-50C-D</b>	527	245	394	78.2	166	S7	2-1/2	1/2	4	
200	28.00	1680	989	<b>A210-50-64D-D</b>	527	245	501	96.3	216	S9	3	1/2	5	

\* Connectors and stub bolts can be customized. Please contact KAORI for further information.

## D Type-A Series Desiccant/ Refrigerated Combination BPHE

- Enhance the drying capacity of adsorption dryer, and extend the cycle time of adsorption.
- With KAORI A series advantage of low dew point, higher moisture removal capacity, controllable dew point(3~10°C), not only increase the capacity of desiccant air dryer but also reduce the cycle time of regeneration.
- The special design of KAORI A series can improve the performance of desiccant dryer, reduce the installation space, and high efficiency vapor removal can reduce the usage amount of adsorbent.
- Easy installation, save the cost of piping.
- Save cost on operation and maintenance.

**\*Could combine with additional KAORI heat recovery BPHE, the heat of high temperature refrigerant could be recovered by air, and the heated hot air could be used for the regeneration cycle of desiccant air dryer, by only consuming 3 to 5% of the purge air, which is more energy saving and environment friendly.**

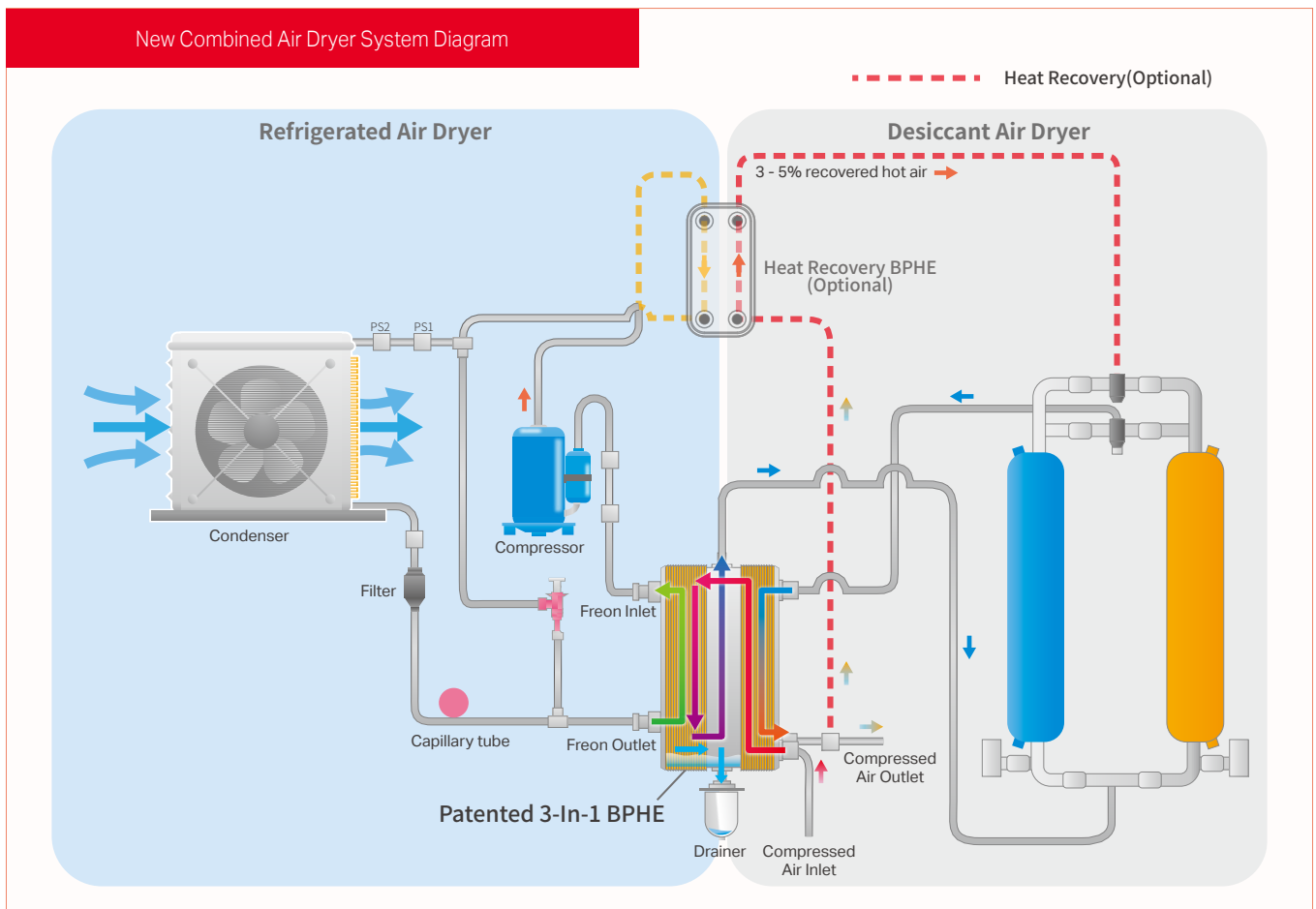



# R Type-A Series Refrigerant Heat Recovery BPHE

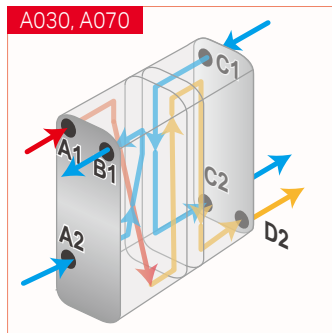
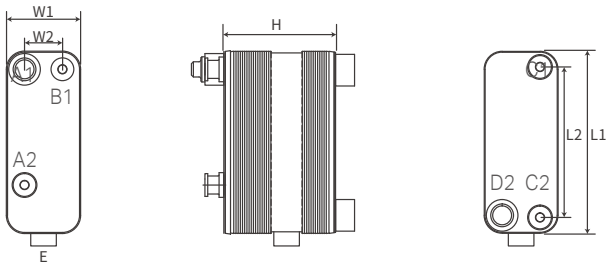

Specification		
Model	A030	A070
MAX. Working Temperature	200°C	
L1 (mm)	192	304
L2 (mm)	154	250
W1 (mm)	78	124
W2 (mm)	40	70
Max Working Pressure (bar)	Air Side	16
	Ref. Side	45
Air Inlet	A1	
Air Outlet	D2	
Condenser Ref. In	C1	
Condenser Ref. Out	C2	
Evaporator Ref. In	A2	
Evaporator Ref. Out	B1	
Drainer	E	

R Type is designed for equipments in specific industries that require precise control of dry compressed air temperatures. R Type is a three-in-one heat exchanger with a condenser, an evaporator, and a gas-water separator.

The compressed air that has reached the dew point temperature can be separated from the high-temperature refrigerant by the gas-water separation, and the heat of the refrigerant can be recovered to preheat. The R Type non-electric heating type utilizes principles of heat pumps, and the flow direction of the condenser can be adjusted to increase the stability of the system. It is suitable for cold-drying machines in precision processing equipments, semiconductor equipments, precision coating, 3D measurement and other equipments.

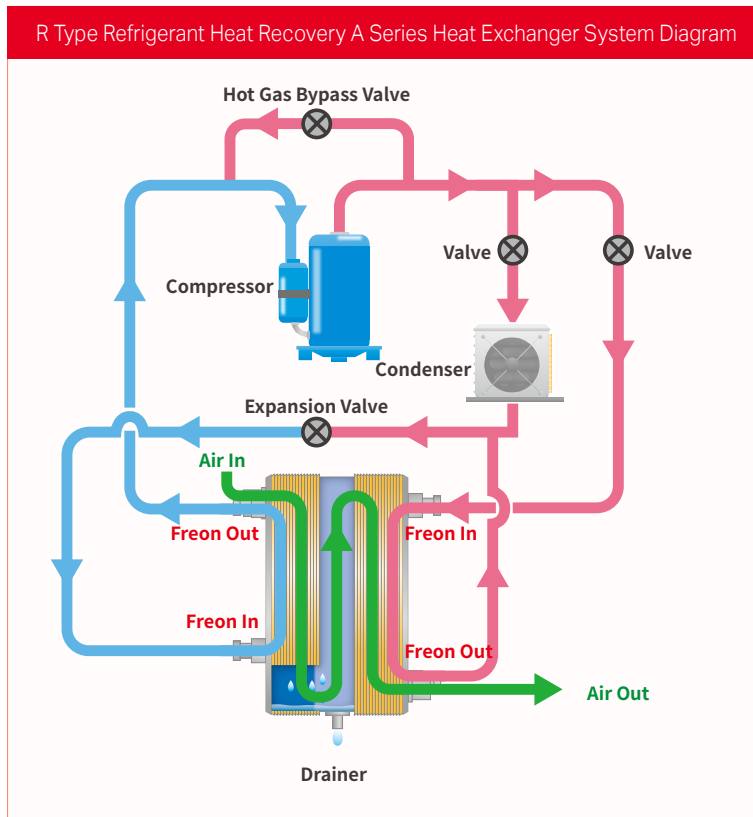

## KAORI A series Compared with Other 3-In-1 Heat Exchangers

	KAORI A series	Other brand 3-in-1	Aluminum Heat Exchanger
Size	<b>Small</b>	Small	Large
Material	<b>Stainless Steel</b>	Stainless Steel	Aluminum
Life	<b>Longer</b>	Shorter	Short
Pressure	<b>High</b>	High	Low
Air Inlet Temp.	<b>High</b>	High	Low
Air Compressor Power	<b>200HP</b>	50HP	Under 500HP (Complicated Structure)
Separating Methods	<b>Combined Separator, No Clogging</b>	With Mesh, Easy Clog	With Mesh, Easy Clog
Built-In Mesh	<b>None</b>	Yes	Yes
Clogging Potential	<b>None</b>	High	High
Internal Air Leakage Test	<b>Yes</b>	None	None

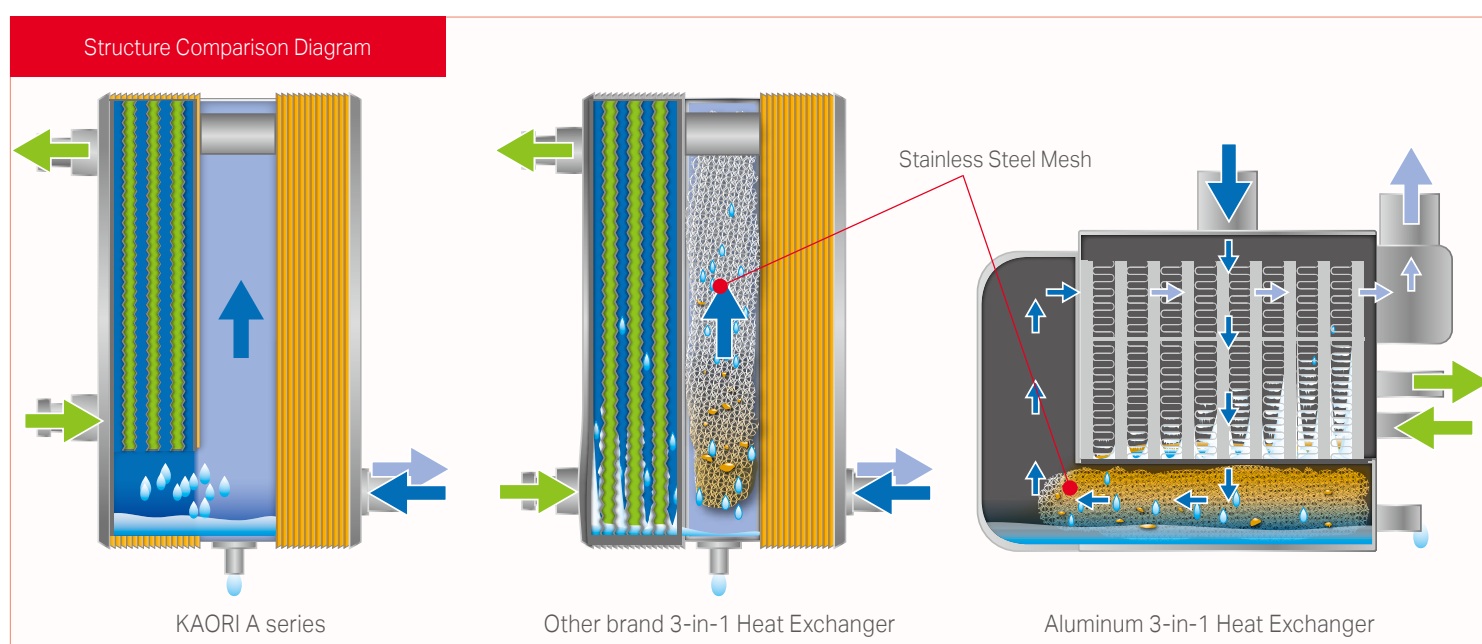

With KAORI exclusive designed separator, moisture and compressed air are effectively separated by gravity and centrifugal force, with exclusive non-mesh design could efficiently avoid the ice or oil clogging problems and extend the usage life.

Other brand 3-in-1 BPHE, and aluminum heat exchangers are built with a mesh to separate water vapor from compressed air. Although high density mesh could reduce the size of separator, but the built-in mesh have a high-potential clogging problems (oil or foreign objects), as a result, air drying capacity will decrease as the usage time increases.

- **Unique Design Separator**

KAORI's distinct non-mesh design separator has advantages of lower pressure drop, clogging free, maintenance free, and longer service life than other heat exchangers.

- **Oil Blockage Free**

Patented plate design of evaporator, shorten the flow path of refrigerant by 30%, with the smooth surface of SUS 304, KAORI can prevent lubricant oil residual which happens frequently in aluminum plate fin heat exchangers.

- **No Ice Blockage**

With KAORI patented plate design of evaporator, condensed water will not remain on the plates, but directly enters to a separation space of the evaporator, which effectively reduce the risk of ice blockage.

- **Equipped with Patented Leakage Testing Connector**

Leading and multinational patent technology, exclusively ensures excellent quality of KAORI 3-in-1 brazed plate heat exchanger.

# KAORI A Series Compared with Shell & Tube Heat Exchangers

	KAORI A series	Shell & Tube
Size	<b>Smaller</b>	2 Times Bigger Than A Series
Weight	<b>Light</b>	Heavy
Tubing	<b>Easy</b>	Complicated
Labor Cost	<b>Low</b>	High
Material	<b>Stainless Steel</b>	Iron / Stainless Steel
Life	<b>Long</b>	Short / Long
Working Pressure	<b>High</b>	High
Inlet Air Temp.	<b>High</b>	Low
Dew Point Temp.	<b>Low</b>	High
Internal Air Leakage Test	<b>Yes</b>	None

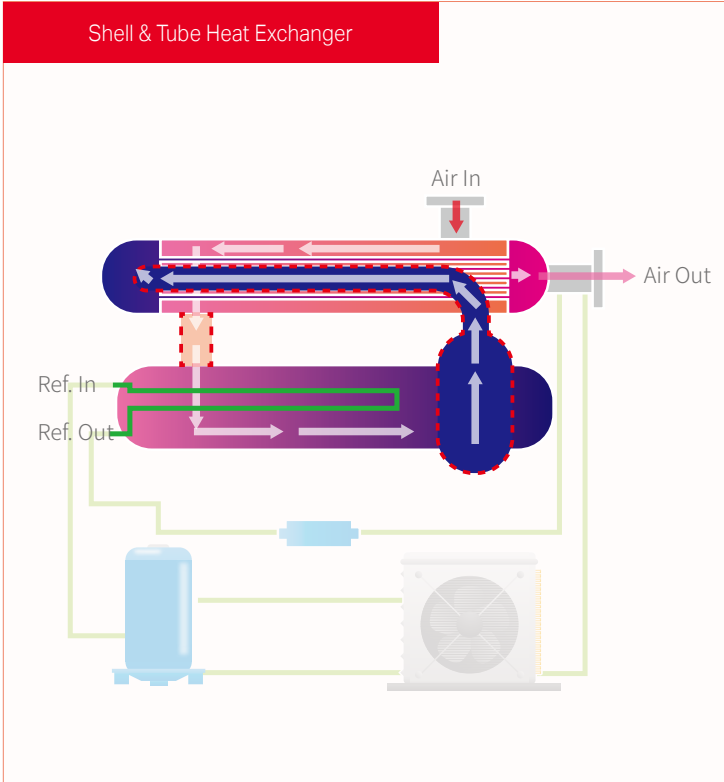
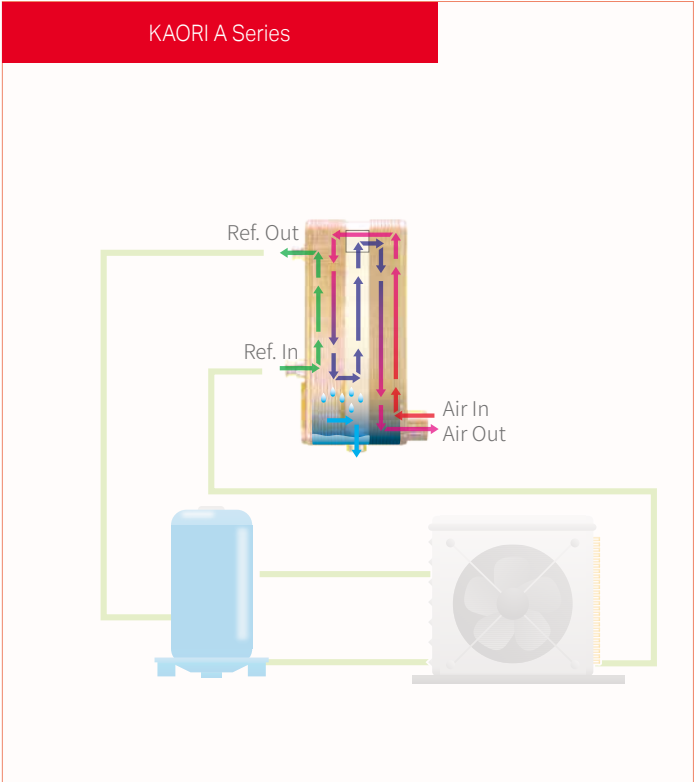

## KAORI A Series Compared with Other 2-In-1 Heat Exchangers

	KAORI A series	2-in-1 heat exchangers
Size	<b>Small</b>	Larger
Weight	<b>Light</b>	Light
Piping	<b>Easy</b>	Complicated
Labor Cost	<b>Low</b>	High
Material	<b>Stainless Steel</b>	Stainless Steel
Life	<b>Long</b>	Long
Pressure	<b>High</b>	High
Air Inlet Temp.	<b>High</b>	High
Pressure Drop	<b>Lower</b>	Higher
Dew Point Temp.	<b>Low</b>	Low
Air Compressor Horse Power	<b>200HP</b>	200HP
Separating Method	<b>Combined Separator No Clogging</b>	External Demand
Internal Air Leakage Test	<b>Yes</b>	None

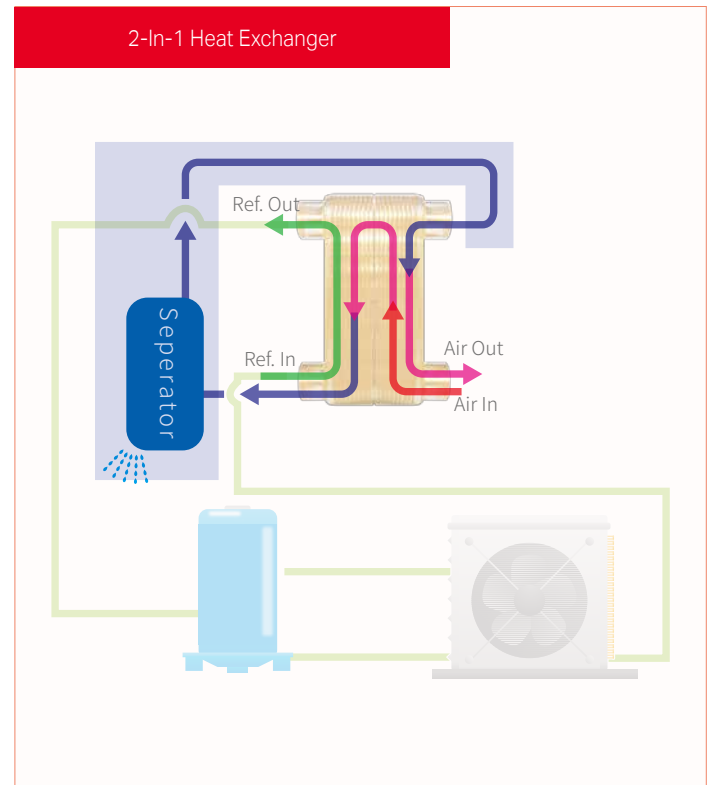
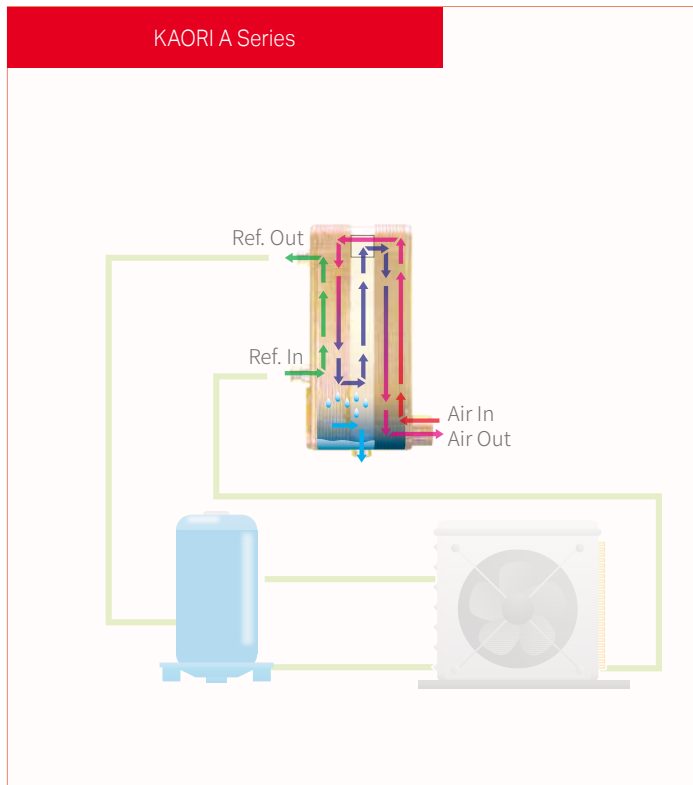

KAORI A series is an easy tubing heat exchanger which combined with a separator, as long as you connect the air inlet/outlet connectors, it's ready for use in your operation.

2-in-1 heat exchanger need to connect with an external separator, more complicated tubing, and expend more on labor cost.



# Air Compressor Heat Recovery System BPHE (K200)



**High Efficiency  
Heat Recovery**



**Recovery Hot Water  
Up to 65° C**



**Special Designed Loop  
Small Size, Easy Installation**



**Saving Air Compressor Life,  
Environmental Friendly**

During the compressing process of air compressor, it discharges high temperature air and high temperature lube oil. With the special loop of KAORI K200, hot air and lube oil can efficiently exchange temperature with water. As a result, the heat of compression can be recovered for hot water use in your application.

## Air Dryer's Heat Recovery System Drawing

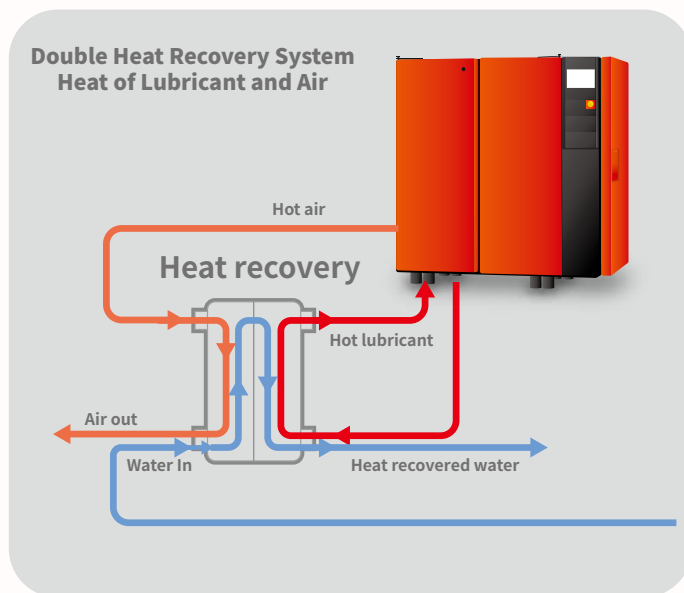
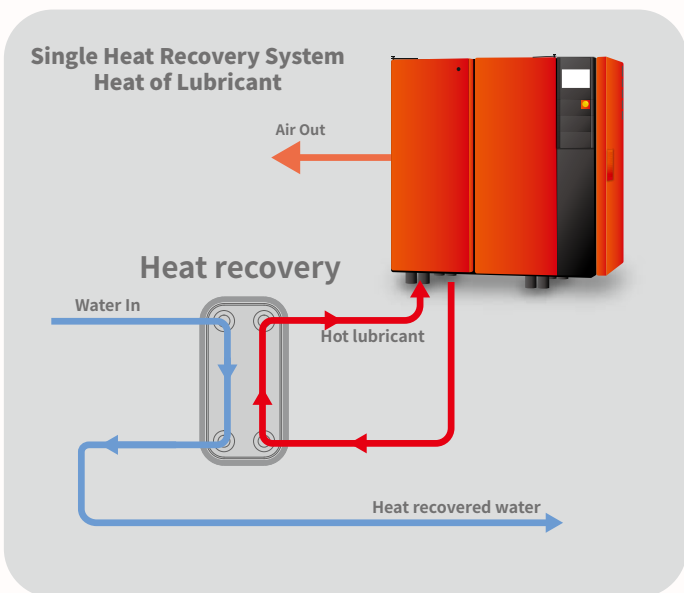

## Air Compressor Double Heat Recovery System Selection Table (Air + Oil)

During the compression process of an air compressor, the shaft power will be converted to thermal energy, then this heat energy will be taken away by circulating oil and compressed air. In general, the recyclable heat from air compressor is about 75%, while the remaining will be discharged into atmosphere.

In the oil-flooded compressor, the circulating oil accounts 80~90% of heat energy, and the compressed air accounts about 10~20%, in addition, the circulating oil can reach up to 100°C. By the advantage of KAORI multi-pass plate heat exchanger, the application water can be recovered to 65°C, it can be applied directly to your operations .

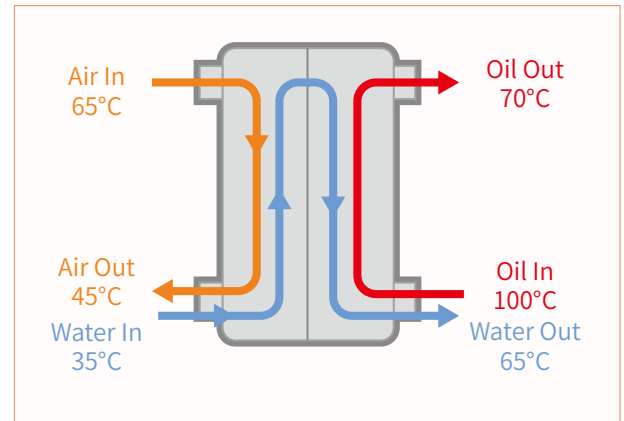

Specification	Unit	Capacity					
Air Compressor	HP	150	200	250	300	400	500
Power	kW	112.5	150	187.5	225	300	375
Heat Recovery	%	75	75	75	75	75	75
Efficacy	kW	84.4	112.5	140.6	168.8	225.0	281.3
<b>Model</b>		<b>K200-44-24</b>	<b>K200-60-32</b>	<b>K200-80-40</b>	<b>K200-110-50</b>	<b>K210-150*</b> <b>K200-64 *</b>	<b>K210-210*</b> <b>K200-80 *</b>
Water Inlet Temp.	°C	35	35	35	35	35	35
Water Outlet Temp.	°C	65	65	65	65	65	65
Flow Rate	LPM	40.2	53.6	67.0	80.4	107.1	133.9
<b>Air Cooler Plates</b>		<b>44</b>	<b>60</b>	<b>80</b>	<b>110</b>	<b>K210-150</b>	<b>K210-210</b>
Air Pressure	barG	7	7	7	7	7	7
Air Inlet Temp.	°C	65	65	65	65	65	65
Air Outlet Temp.	°C	45	45	45	45	45	45
Air Recovery Rate	kW	8.4	11.3	14.1	16.9	22.5	28.1
Air Side Pressure Drop	kPa	<25	<25	<25	<25	<25	<30
<b>Oil Condenser Plates</b>		<b>24</b>	<b>32</b>	<b>40</b>	<b>50</b>	<b>K200-64</b>	<b>K200-80</b>
Oil Type		VG68	VG68	VG68	VG68	VG68	VG68
Oil Inlet Temp	°C	100	100	100	100	100	100
Oil Outlet Temp	°C	70	70	70	70	70	70
Oil Recovery Rate	kW	75.9	101.3	126.6	151.9	202.5	253.1

\* Models above 400HP have different oil/ air condenser.

\* Single heat recovery heat exchanger model could be selected base on different working conditions.

# Oil Cooler/ After Cooler Application for Air Compressor

## Oil Injection Screw Compressor Cooling System

During the compressing process of oil injection screw compressor, it discharges hot air & hot lube oil to the oil separator, the hot air and hot lube oil separately enter into different inlet of plate heat exchanger to exchange heat with water, by recovering heat from the compression, water becomes hot, and ready for use.

## Oil Injection Screw Compressor Cooling System ( Include Drain Separator)

During the compressing process of oil injection screw compressor, it discharges hot air & hot lube oil to the oil separator, the hot air and hot lube oil separately enter into different inlet of plate heat exchanger to exchange heat with water. Next, while lube oil goes back to air compressor, the compressed air keeps moving to the separator to remove moisture from it. After all, you can cool down the circulating oil, the compressed air, and separate moistures from air with KAORI single 3-in-1 heat exchanger

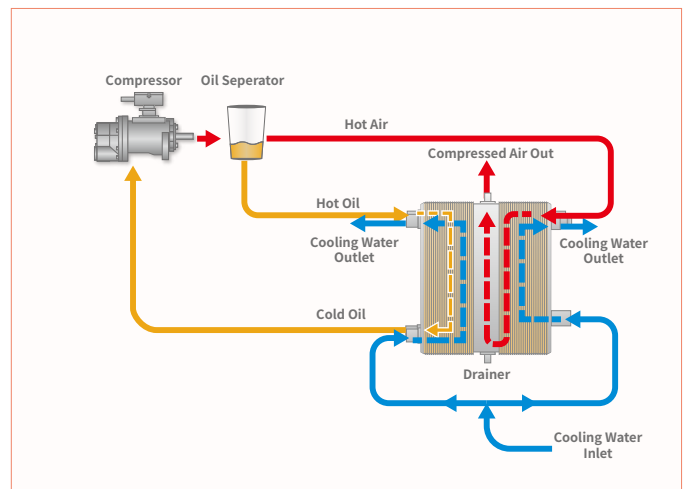
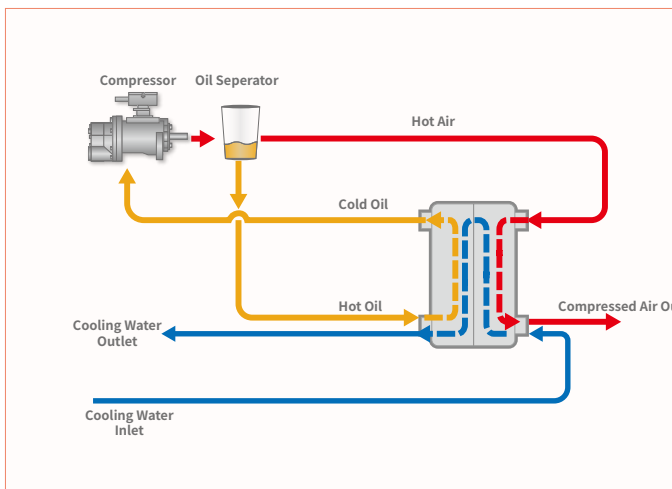

## Oil Free Screw Cooling System Intercooler Include Drain

To achieve higher capacity, oil free screw compressor uses two stages to compress air. After the first compressing stage, air enters plate heat exchanger to process the first cooling and moisture separation, then goes back to air compressor for the second stage. After the second compressing stage, it re-enters into plate heat exchanger to be cooled down to the applicable temperature.

## Water Lubricated Screw Compressor Cooling System

Water cycle oil less compressor transfers heat to its internal lubricate water during the compression. To prevent temperature of water goes too high, and to extend compressor's life, plate heat exchanger can cool the internal circulating water through external low temperature water with higher efficiency and we ensure that these won't mix with each other.

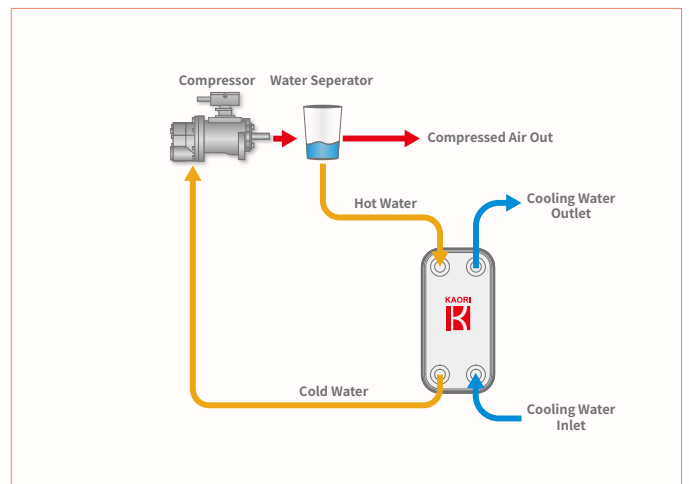
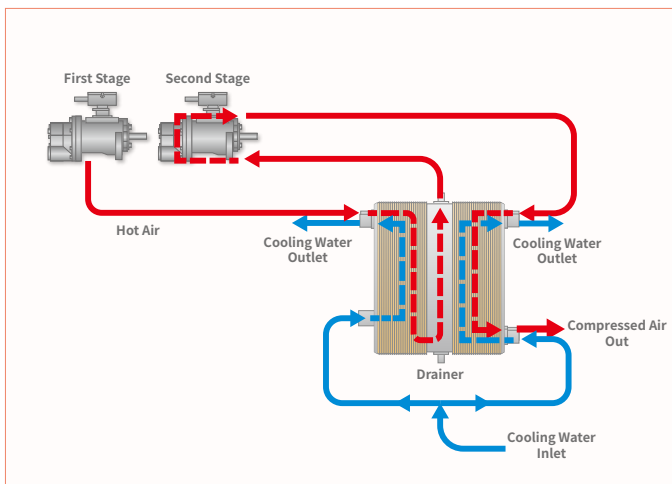

## Air Dryer Selection Table(Air Inlet Temp. :35°C)

### Air Inlet Temp. = 35°C , Dew Point = 3°C

Air Compressor Power	Air Flow Rate @ 7barG			Model	Length	Width	Height	Weight	Separator Height	Air Side Connector
	HP	Nm³/min	Nm³/hr							
5	0.58	35	21	<b>A030-14-8A</b>	192	78	99	2.8	44	3/4
8	0.83	50	29	<b>A030-20-10A</b>	192	78	117	3.1	44	3/4
10	1.00	60	35	<b>A030-22-12A</b>	192	78	126	3.3	44	3/4
12	1.33	80	47	<b>A030-24-16A</b>	192	78	139	3.6	44	3/4
15	1.67	100	59	<b>A030-40-24A</b>	192	78	194	4.6	44	3/4
20	2.40	144	85	<b>A070-20-26A</b>	304	124	156	10.7	45	3/4
30	4.20	252	148	<b>A070-32-40B</b>	304	124	229	13.9	60	1-1/4
50	7.00	420	247	<b>A070-46-66C</b>	304	124	348	19.8	90	1-1/2
75	11.00	660	388	<b>A140-24-36A</b>	441	206	224	30.8	79	2
100	14.00	840	494	<b>A140-32-44B</b>	441	206	280	36.4	99	2
150	22.00	1320	777	<b>A210-40-50C</b>	527	245	394	78.2	166	2-1/2
200	28.00	1680	989	<b>A210-50-64D</b>	527	245	501	96.3	216	3

### Air Inlet Temp. = 35°C , Dew Point = 7°C

Air Compressor Power	Air Flow Rate @ 7barG			Model	Length	Width	Height	Weight	Separator Height	Air Side Connector
	HP	Nm³/min	Nm³/hr							
5	0.58	35	21	<b>A030-12-6A</b>	192	78	90	2.6	44	3/4
8	0.83	50	29	<b>A030-18-8A</b>	192	78	108	2.9	44	3/4
10	1.00	60	35	<b>A030-18-10A</b>	192	78	112	3.0	44	3/4
12	1.33	80	47	<b>A030-22-12A</b>	192	78	126	3.3	44	3/4
15	1.67	100	59	<b>A030-24-16A</b>	192	78	139	3.6	44	3/4
20	2.40	144	85	<b>A030-42-28A</b>	192	78	207	4.8	44	3/4
30	4.20	252	148	<b>A070-26-32B</b>	304	124	198	12.4	60	1-1/4
50	7.00	420	247	<b>A070-40-52B</b>	304	124	303	17.7	60	1-1/2
75	11.00	660	388	<b>A140-20-28A</b>	441	206	196	28.1	79	2
100	14.00	840	494	<b>A140-24-34B</b>	441	206	239	32.2	99	2
150	22.00	1320	777	<b>A210-30-38C</b>	527	245	342	68.9	166	2-1/2
200	28.00	1680	989	<b>A210-38-48D</b>	527	245	435	84.4	216	3

### Air Inlet Temp. = 35°C , Dew Point = 10°C

Air Compressor Power	Air Flow Rate @ 7barG			Model	Length	Width	Height	Weight	Separator Height	Air Side Connector
	HP	Nm³/min	Nm³/hr							
5	0.58	35	21	<b>A030-10-6A</b>	192	78	85	2.5	44	3/4
8	0.83	50	29	<b>A030-14-8A</b>	192	78	99	2.8	44	3/4
10	1.00	60	35	<b>A030-18-8A</b>	192	78	108	2.9	44	3/4
12	1.33	80	47	<b>A030-22-10A</b>	192	78	121	3.2	44	3/4
15	1.67	100	59	<b>A030-24-14A</b>	192	78	135	3.5	44	3/4
20	2.40	144	85	<b>A030-40-24A</b>	192	78	194	4.6	44	1
30	4.20	252	148	<b>A070-22-28B</b>	304	124	180	11.7	60	1-1/4
50	7.00	420	247	<b>A070-36-46C</b>	304	124	281	16.3	90	1-1/2
75	11.00	660	388	<b>A140-18-24A</b>	441	206	183	26.7	79	2
100	14.00	840	494	<b>A140-22-30B</b>	441	206	226	30.8	99	2
150	22.00	1320	777	<b>A210-28-36C</b>	527	245	333	67.2	166	2-1/2
200	28.00	1680	989	<b>A210-34-44D</b>	527	245	416	81.0	216	3

## Air Dryer Selection Table(Air Inlet Temp. :40°C)

### Air Inlet Temp. = 40°C , Dew Point = 3°C

Air Compressor Power	Air Flow Rate @ 7barG			Model	Length	Width	Height	Weight	Separator Height	Air Side Connector
	HP	Nm³/min	Nm³/hr							
5	0.58	35	21	A030-10-6A	192	78	85	2.5	44	3/4
8	0.83	50	29	A030-14-8A	192	78	99	2.8	44	3/4
10	1.00	60	35	A030-18-8A	192	78	108	2.9	44	3/4
12	1.33	80	47	A030-22-10A	192	78	121	3.2	44	3/4
15	1.67	100	59	A030-24-14A	192	78	135	3.5	44	3/4
20	2.40	144	85	A030-40-24A	192	78	194	4.6	44	1
30	4.20	252	148	A070-22-28B	304	124	180	11.7	60	1-1/4
50	7.00	420	247	A070-36-46C	304	124	281	16.3	90	1-1/2
75	11.00	660	388	A140-18-24A	441	206	183	26.7	79	2
100	14.00	840	494	A140-36-54B	441	206	311	39.6	99	2
150	22.00	1320	777	A210-28-36C	527	245	333	67.2	166	2-1/2
200	28.00	1680	989	A210-34-44D	527	245	416	81.0	216	3

### Air Inlet Temp. = 40°C , Dew Point = 7°C

Air Compressor Power	Air Flow Rate @ 7barG			Model	Length	Width	Height	Weight	Separator Height	Air Side Connector
	HP	Nm³/min	Nm³/hr							
5	0.58	35	21	A030-14-8A	192	78	99	2.8	44	3/4
8	0.83	50	29	A030-18-10A	192	78	112	3.0	44	3/4
10	1.00	60	35	A030-22-10A	192	78	121	3.2	44	3/4
12	1.33	80	47	A030-24-14A	192	78	135	3.5	44	3/4
15	1.67	100	59	A030-36-22A	192	78	180	4.3	44	3/4
20	2.40	144	85	A070-18-24A	304	124	147	10.2	45	1
30	4.20	252	148	A070-30-36B	304	124	215	13.2	60	1-1/4
50	7.00	420	247	A070-44-58C	304	124	326	18.8	90	1-1/2
75	11.00	660	388	A140-24-32A	441	206	219	29.9	79	2
100	14.00	840	494	A140-28-40B	441	206	266	34.5	99	2
150	22.00	1320	777	A210-36-44C	527	245	371	73.9	166	2-1/2
200	28.00	1680	989	A210-46-56D	527	245	473	91.1	216	3

### Air Inlet Temp. = 40°C , Dew Point = 10°C

Air Compressor Power	Air Flow Rate @ 7barG			Model	Length	Width	Height	Weight	Separator Height	Air Side Connector
	HP	Nm³/min	Nm³/hr							
5	0.58	35	21	A030-12-8A	192	78	94	2.7	44	3/4
8	0.83	50	29	A030-18-8A	192	78	108	2.9	44	3/4
10	1.00	60	35	A030-20-10A	192	78	117	3.1	44	3/4
12	1.33	80	47	A030-24-12A	192	78	130	3.4	44	3/4
15	1.67	100	59	A030-24-16A	192	78	139	3.6	44	3/4
20	2.40	144	85	A070-16-20A	304	124	133	9.6	45	1
30	4.20	252	148	A070-26-32B	304	124	198	12.4	60	1-1/4
50	7.00	420	247	A070-40-52C	304	124	303	17.7	90	1-1/2
75	11.00	660	388	A140-20-30A	441	206	201	28.5	79	2
100	14.00	840	494	A140-26-38B	441	206	253	33.6	99	2
150	22.00	1320	777	A210-32-40C	527	245	352	70.6	166	2-1/2
200	28.00	1680	989	A210-40-52D	527	245	449	87.0	216	3



## Air Dryer Selection Table(Air Inlet Temp. :45°C)

### Air Inlet Temp. = 45°C , Dew Point = 3°C

Air Compressor Power	Air Flow Rate @ 7barG			Model	Length	Width	Height	Weight	Separator Height	Air Side Connector
	HP	Nm³/min	Nm³/hr							
5	0.58	35	21	A030-20-10A	192	78	117	3.1	44	3/4
8	0.83	50	29	A030-24-14A	192	78	135	3.5	44	3/4
10	1.00	60	35	A030-24-16A	192	78	139	3.6	44	3/4
12	1.33	80	47	A030-42-28A	192	78	207	4.8	44	3/4
15	1.67	100	59	A070-20-24A	304	124	151	10.4	45	3/4
20	2.40	144	85	A070-26-32A	304	124	183	11.8	45	1
30	4.20	252	148	A070-40-54B	304	124	278	16.5	60	1-1/4
50	7.00	420	247	A140-22-30A	441	206	206	29.0	79	1-1/2
75	11.00	660	388	A140-34-48A	441	206	273.3	35.9	79	2
100	14.00	840	494	A210-34-44B	527	245	296	66.5	96	2
150	22.00	1320	777	A210-54-68C	527	245	470	91.8	166	2-1/2
200	28.00	1680	989	--	--	--	--	--	--	--

### Air Inlet Temp. = 45°C , Dew Point = 7°C

Air Compressor Power	Air Flow Rate @ 7barG			Model	Length	Width	Height	Weight	Separator Height	Air Side Connector
	HP	Nm³/min	Nm³/hr							
5	0.58	35	21	A030-14-8A	192	78	99	2.8	44	3/4
8	0.83	50	29	A030-20-10A	192	78	117	3.1	44	3/4
10	1.00	60	35	A030-22-12A	192	78	126	3.3	44	3/4
12	1.33	80	47	A030-24-16A	192	78	139	3.6	44	3/4
15	1.67	100	59	A030-40-24A	192	78	194	4.6	44	3/4
20	2.40	144	85	A070-20-26A	304	124	156	10.7	45	1
30	4.20	252	148	A070-32-40B	304	124	229	13.9	60	1-1/4
50	7.00	420	247	A070-46-66C	304	124	348	19.8	90	1-1/2
75	11.00	660	388	A140-24-36A	441	206	224	30.8	79	2
100	14.00	840	494	A140-32-44B	441	206	280	36.4	99	2
150	22.00	1320	777	A210-40-50C	527	245	394	78.2	166	2-1/2
200	28.00	1680	989	A210-50-64D	527	245	501	96.3	216	3

### Air Inlet Temp. = 45°C , Dew Point = 10°C

Air Compressor Power	Air Flow Rate @ 7barG			Model	Length	Width	Height	Weight	Separator Height	Air Side Connector
	HP	Nm³/min	Nm³/hr							
5	0.58	35	21	A030-14-8A	192	78	99	2.8	44	3/4
8	0.83	50	29	A030-18-10A	192	78	112	3.0	44	3/4
10	1.00	60	35	A030-22-10A	192	78	121	3.2	44	3/4
12	1.33	80	47	A030-24-14A	192	78	135	3.5	44	3/4
15	1.67	100	59	A030-36-22A	192	78	180	4.3	44	3/4
20	2.40	144	85	A070-18-24A	304	124	147	10.2	45	1
30	4.20	252	148	A070-30-36B	304	124	215	13.2	60	1-1/4
50	7.00	420	247	A070-44-60C	304	124	330	19.0	90	1-1/2
75	11.00	660	388	A140-24-32A	441	206	215	29.9	79	2
100	14.00	840	494	A140-30-42B	441	206	271	35.5	99	2
150	22.00	1320	777	A210-36-44C	527	245	371	73.9	166	2-1/2
200	28.00	1680	989	A210-46-58D	527	245	477	92.0	216	3

## Air Dryer Selection Table(Air Inlet Temp. :50°C)

### Air Inlet Temp. = 50°C , Dew Point = 3°C

Air Compressor Power	Air Flow Rate @ 7barG			Model	Length	Width	Height	Weight	Separator Height	Air Side Connector
	HP	Nm³/min	Nm³/hr							
5	0.58	35	21	A030-22-12A	192	78	126	3.3	44	3/4
8	0.83	50	29	A030-32-20A	192	78	166	4.1	44	3/4
10	1.00	60	35	A030-40-24A	192	78	194	4.6	44	3/4
12	1.33	80	47	A070-20-24A	304	124	151	10.4	45	3/4
15	1.67	100	59	A070-22-28A	304	124	165	11.1	45	3/4
20	2.40	144	85	A070-32-38A	304	124	209	13.0	45	1
30	4.20	252	148	A070-46-66B	304	124	318	18.4	60	1-1/4
50	7.00	420	247	A140-28-38A	441	206	237	32.3	79	1-1/2
75	11.00	660	388	A210-34-42B	527	245	291	65.5	96	2
100	14.00	840	494	A210-42-54B	527	245	339	74.1	96	2
150	22.00	1320	777	--	--	--	--	--	--	--
200	28.00	1680	989	--	--	--	--	--	--	--

### Air Inlet Temp. = 50°C , Dew Point = 7°C

Air Compressor Power	Air Flow Rate @ 7barG			Model	Length	Width	Height	Weight	Separator Height	Air Side Connector
	HP	Nm³/min	Nm³/hr							
5	0.58	35	21	A030-18-10A	192	78	112	3.0	44	3/4
8	0.83	50	29	A030-24-12A	192	78	130	3.4	44	3/4
10	1.00	60	35	A030-24-16A	192	78	139	3.6	44	3/4
12	1.33	80	47	A030-40-24A	192	78	194	4.6	44	3/4
15	1.67	100	59	A070-18-24A	304	124	147	10.2	45	3/4
20	2.40	144	85	A070-24-30A	304	124	174	11.5	45	1
30	4.20	252	148	A070-40-52B	304	124	273	16.3	60	1-1/4
50	7.00	420	247	A140-20-30A	441	206	201	28.5	79	1-1/2
75	11.00	660	388	A140-32-44A	441	206	260	34.6	79	2
100	14.00	840	494	A210-32-40B	527	245	282	63.9	96	2
150	22.00	1320	777	A210-50-64C	527	245	451	88.4	166	2-1/2
200	28.00	1680	989	--	--	--	--	--	--	--

### Air Inlet Temp. = 50°C , Dew Point = 10°C

Air Compressor Power	Air Flow Rate @ 7barG			Model	Length	Width	Height	Weight	Separator Height	Air Side Connector
	HP	Nm³/min	Nm³/hr							
5	0.58	35	21	A030-18-8A	192	78	108	2.9	44	3/4
8	0.83	50	29	A030-22-12A	192	78	126	3.3	44	3/4
10	1.00	60	35	A030-24-14A	192	78	135	3.5	44	3/4
12	1.33	80	47	A030-36-22A	192	78	180	4.3	44	3/4
15	1.67	100	59	A030-42-28A	192	78	207	4.8	44	3/4
20	2.40	144	85	A070-22-28A	304	124	165	11.1	45	1
30	4.20	252	148	A070-36-46B	304	124	251	14.9	60	1-1/4
50	7.00	420	247	A140-20-26A	441	206	192	27.6	79	1-1/2
75	11.00	660	388	A140-28-40A	441	206	242	32.7	79	2
100	14.00	840	494	A140-36-52B	441	206	307	39.1	99	2
150	22.00	1320	777	A210-46-56C	527	245	423	83.3	166	2-1/2
200	28.00	1680	989	--	--	--	--	--	--	--

## Air Dryer Selection Table(Air Inlet Temp. :55°C)

### Air Inlet Temp. = 55°C , Dew Point = 3°C

Air Compressor Power	Air Flow Rate @ 7barG			Model	Length	Width	Height	Weight	Separator Height	Air Side Connector
	HP	Nm³/min	Nm³/hr							
5	0.58	35	21	<b>A030-24-14A</b>	192	78	135	3.5	44	3/4
8	0.83	50	29	<b>A030-40-26A</b>	192	78	198	4.7	44	3/4
10	1.00	60	35	<b>A070-18-24A</b>	304	124	147	10.2	45	3/4
12	1.33	80	47	<b>A070-22-28A</b>	304	124	165	11.1	45	3/4
15	1.67	100	59	<b>A070-28-34A</b>	304	124	191	12.2	45	3/4
20	2.40	144	85	<b>A070-38-48A</b>	304	124	245	14.7	45	1
30	4.20	252	148	<b>A140-20-30A</b>	441	206	201	28.5	79	1-1/4
50	7.00	420	247	<b>A140-32-46A</b>	441	206	264	35	79	1-1/2
75	11.00	660	388	<b>A210-40-52B</b>	527	245	329	72.4	96	2
100	14.00	840	494	<b>A210-52-66B</b>	527	245	390	83.4	96	2
150	22.00	1320	777	--	--	--	--	--	--	--
200	28.00	1680	989	--	--	--	--	--	--	--

### Air Inlet Temp. = 55°C , Dew Point = 7°C

Air Compressor Power	Air Flow Rate @ 7barG			Model	Length	Width	Height	Weight	Separator Height	Air Side Connector
	HP	Nm³/min	Nm³/hr							
5	0.58	35	21	<b>A030-22-10A</b>	192	78	121	3.2	44	3/4
8	0.83	50	29	<b>A030-24-16A</b>	192	78	139	3.6	44	3/4
10	1.00	60	35	<b>A030-38-22A</b>	192	78	185	4.4	44	3/4
12	1.33	80	47	<b>A070-18-24A</b>	304	124	147	10.2	45	3/4
15	1.67	100	59	<b>A070-22-26A</b>	304	124	160	10.9	45	3/4
20	2.40	144	85	<b>A070-28-36A</b>	304	124	196	12.4	45	1
30	4.20	252	148	<b>A070-44-60B</b>	304	124	300	17.5	60	1-1/4
50	7.00	420	247	<b>A140-24-36A</b>	441	206	224	30.8	79	1-1/2
75	11.00	660	388	<b>A210-30-38B</b>	527	245	272	62.2	96	2
100	14.00	840	494	<b>A210-40-50B</b>	527	245	324	71.5	96	2
150	22.00	1320	777	--	--	--	--	--	--	--
200	28.00	1680	989	--	--	--	--	--	--	--

### Air Inlet Temp. = 55°C , Dew Point = 10°C

Air Compressor Power	Air Flow Rate @ 7barG			Model	Length	Width	Height	Weight	Separator Height	Air Side Connector
	HP	Nm³/min	Nm³/hr							
5	0.58	35	21	<b>A030-20-10A</b>	192	78	117	3.1	44	3/4
8	0.83	50	29	<b>A030-24-14A</b>	192	78	135	3.5	44	3/4
10	1.00	60	35	<b>A030-32-20A</b>	192	78	166	4.1	44	3/4
12	1.33	80	47	<b>A030-42-28A</b>	192	78	207	4.8	44	3/4
15	1.67	100	59	<b>A070-20-26A</b>	304	124	156	10.7	45	3/4
20	2.40	144	85	<b>A070-26-32A</b>	304	124	183	11.8	45	1
30	4.20	252	148	<b>A070-42-54B</b>	304	124	282	16.7	60	1-1/4
50	7.00	420	247	<b>A140-24-32A</b>	441	206	215	29.9	79	1-1/2
75	11.00	660	388	<b>A140-34-50A</b>	441	206	278	36.4	79	2
100	14.00	840	494	<b>A210-36-44B</b>	527	245	301	67.2	96	2
150	22.00	1320	777	<b>A210-56-70C</b>	527	245	479	93.5	166	2-1/2
200	28.00	1680	989	--	--	--	--	--	--	--



**KAORI**



**KAORI HEAT TREATMENT CO., LTD.**

## **Professionals in Customized Heat Exchangers**



### **HEAD OFFICE**

5-2, Chilin North Road, Chung-Li Industrial Zone, Chung-Li District, Taoyuan City, Taiwan

TEL: +886-3-4626958      FAX: +886-3-4628021

E-Mail: [sales@kaori.com.tw](mailto:sales@kaori.com.tw)

KAORI reserves the right to make changes without prior notice.

2021.07/500

**[www.kaori-bphe.com](http://www.kaori-bphe.com)**