

STUDENT SUPPORT MATERIAL

Class X
Science



Session 2016-17

KENDRIYA VIDYALAYA SANGATHAN
NEW DELHI

STUDENT SUPPORT MATERIAL

ADVISORS

- Shri Santosh Kumar Mall, IAS, Commissioner, KVS (HQ), New Delhi
- Shri U.N. Khaware, Addl. Commissioner (Academics), KVS (HQ)

CO-ORDINATION TEAM AT KVS (HQ)

- Dr. V. Vijayalakshmi, Joint Commissioner (Acad), KVS (HQ)
- Mr. P.V. Sai Ranga Rao, Deputy Commissioner (Acad), KVS (HQ)
- Ms. Aprajita, AEO (Acad), KVS (HQ)

CONTENT TEAM

- Mr. P. Devakumar, Deputy Commissioner, KVS Bangalore Region
- Ms. Jolly R David, TGT (Science), KV RWF, Yelahanka Bangalore
- Ms. Neeta Wage, TGT (Science), KV Hebbal Bangalore
- Ms. Saraswathy Chandran, TGT (Science), KV No.1 Jalahalli Bangalore
- Ms. K Annapoorna Pai, TGT (Science), KV No.1 Jalahalli Bangalore
- Ms. Seema Saraswat, TGT (Science), KV 1 Jalahalli Bangalore

REVIEW TEAM

- MS. Alka Yadav, TGT (Science), KV NSG Manesar
- MS. Preeti Singh Shandilya, TGT (Science), KV Sec-2 RK Puram

INDEX

First Term Units		Page No	Marks
I.	Chemical Substances - Nature & Behaviour Chapter 1. Chemical Reaction and Equations	1	33
	Chapter 2. Acids ,Bases and Salts	5	
	Chapter 3. Metals and Non -metals	10	
II.	World of Living Chapter 6. Life processes	16	21
	Chapter 7. Control and co-ordination	26	
IV.	Effects of Current Chapter 12. Electricity	39	29
	Chapter 13. Magnetic Effects of Electric Current	37	
V.	Natural Resources Chapter 14. Sources of energy	43	7
	Total		90
Second Term Units			Marks
I.	Chemical Substances - Nature & Behaviour Chapter 4. Carbon and its Compounds	50	23
	Chapter 5. Periodic Classification of Elements	56	
II.	World of Living Chapter 8. How do organisms Reproduce?	62	30
	Chapter 9. Heredity and Evolution	70	
III.	Natural Phenomenon Chapter 10. Light- Reflection and Refraction	74	29
	Chapter 11. Human Eye and Colourful world	83	
V.	Natural Resources Chapter 15. Our Environment	89	8
	Chapter 16. Management of Natural Resources	98	
	Total		90
	SAMPLE QUESTION PAPERS	108	

PRACTICALS

First Term

1. To find the pH of the following samples by using pH paper/universal indicator:
 - a. Dilute Hydrochloric Acid
 - b. Dilute NaOH solution
 - c. Dilute Ethanoic Acid solution
 - d. Lemon juice
 - e. Water
 - f. Dilute Sodium Bicarbonate solution
2. To study the properties of acids and bases (HCl & NaOH) by their reaction with:
 - a. Litmus solution (Blue/Red)
 - b. Zinc metal
 - c. Solid sodium carbonate
3. To perform and observe the following reactions and classify them into:
 - i. Combination reaction
 - ii. Decomposition reaction
 - iii. Displacement reaction
 - iv. Double displacement reaction
 - 1) Action of water on quick lime
 - 2) Action of heat on ferrous sulphate crystals
 - 3) Iron nails kept in copper sulphate solution
 - 4) Reaction between sodium sulphate and barium chloride solutions
4. i) To observe the action of Zn, Fe, Cu and Al metals on the following salt solutions:
 - a. ZnSO_4 (aq)
 - b. FeSO_4 (aq)
 - c. CuSO_4 (aq)
 - d. $\text{Al}_2(\text{SO}_4)_3$ (aq)ii) Arrange Zn, Fe, Cu and Al (metals) in the decreasing order of reactivity based on the above result.
5. To study the dependence of potential difference (V) across a resistor on the current (I) passing through it and determine its resistance. Also plot a graph between V and I.
6. To determine the equivalent resistance of two resistors when connected in series.
- 7 To determine the equivalent resistance of two resistors when connected in parallel.
- 8 To prepare a temporary mount of a leaf peel to show stomata.
- 9 To show experimentally that light is necessary for photosynthesis.
- 10 To show experimentally that carbon dioxide is given out during respiration.

SECOND TERM

1. To study the following properties of acetic acid (ethanoic acid):

- i) odour
- ii) solubility in water
- iii) effect on litmus
- iv) reaction with sodium bicarbonate

2. To study saponification reaction for preparation of soap.

3. To study the comparative cleaning capacity of a sample of soap in soft and hard water.

4. To determine the focal length of:

- i. Concave mirror,
- ii. Convex lens,

by obtaining the image of a distant object.

5. To trace the path of a ray of light passing through a rectangular glass slab for different angles of incidence. Measure the angle of incidence, angle of refraction, angle of emergence and interpret the result.

6. To study (a) binary fission in Amoeba, and (b) budding in yeast with the help of prepared slides.

7. To trace the path of the rays of light through a glass prism.

8. To find the image distance for varying object distances in case of a convex lens and draw corresponding ray diagrams to show the nature of image formed.

9. To study homology and analogy with the help of models/charts of animals and models/ charts/ specimens of plants.

10. To identify the different parts of an embryo of a dicot seed (Pea, gram or red kidney bean).

TERM I

CHAPTER 1- CHEMICAL REACTIONS AND EQUATIONS

1. During chemical reactions, chemical composition of substances changes or new substances are formed.

2. Chemical reactions can be written in chemical equation form which should be always balanced.

3. Types of Chemical Reactions

S NO	Types of reactions	Examples
1	Combination reaction A single product is formed from two or more reactants.	$2\text{Mg} + \text{O}_2 \rightarrow 2\text{MgO}$
2	Decomposition reaction A single reactant breaks down to yield two or more products. i) Thermal decomposition	$2\text{Pb}(\text{NO}_3)_2 \rightarrow 2\text{PbO} + 4\text{NO}_2 + \text{O}_2$
	ii) Electrolysis	$2\text{H}_2\text{O} \rightarrow 2\text{H}_2 + \text{O}_2$
	iii) Photo chemical reaction	$2\text{AgBr} \rightarrow 2\text{Ag} + \text{Br}_2$
3	Displacement reaction One element is displaced by another element.	$\text{Zn} + \text{CuSO}_4 \rightarrow \text{ZnSO}_4 + \text{Cu}$
4	Double displacement reaction Exchange of ions between reactants.	$\text{AgNO}_3 + \text{NaCl} \rightarrow \text{AgCl} + \text{NaNO}_3$
5	Redox reaction Both oxidation and reduction take place simultaneously	$\text{CuO} + \text{H}_2 \rightarrow \text{Cu} + \text{H}_2\text{O}$

4. i) **Exothermic reaction:** A chemical reaction in which heat energy is evolved.



ii) **Endothermic reaction:** A chemical reaction in which heat energy is absorbed.

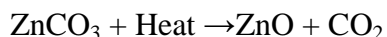

5. **Redox reaction:** Chemical reaction in which both oxidation and reduction take place simultaneously.

Oxidation: Reaction that involves the gain of oxygen or loss of hydrogen.

Reduction: Reaction that shows the loss of oxygen or gain of hydrogen

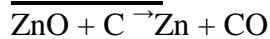

ZnO is reduced to Zn -reduction

C is oxidized to CO -----oxidation

6. Effectsof oxidation reactions in our daily life:

a) **Corrosion:** It is an undesirable change that occurs in metals, when they are attacked by moisture, air, acids and bases.

Corrosion (rusting) of iron: $\text{Fe}_2\text{O}_3 \cdot x\text{H}_2\text{O}$ (Hydrated iron oxide)

Corrosion of copper: $\text{CuCO}_3 \cdot \text{Cu}(\text{OH})_2$ (Basic copper carbonate)

Corrosion of silver: Ag_2S (Silver sulphide)

Corrosion of Aluminum: Al_2O_3 (Aluminum oxide)

b) **Rancidity:** Undesirable change that takes place in oil containing food items due to the oxidation of fatty acids.

Preventive methods

- (1) Adding antioxidants to the food materials.
- (2) Storing food in air tight container
- (3) Flushing out air with nitrogen gas.
- (4) Refrigeration

MIND MAP

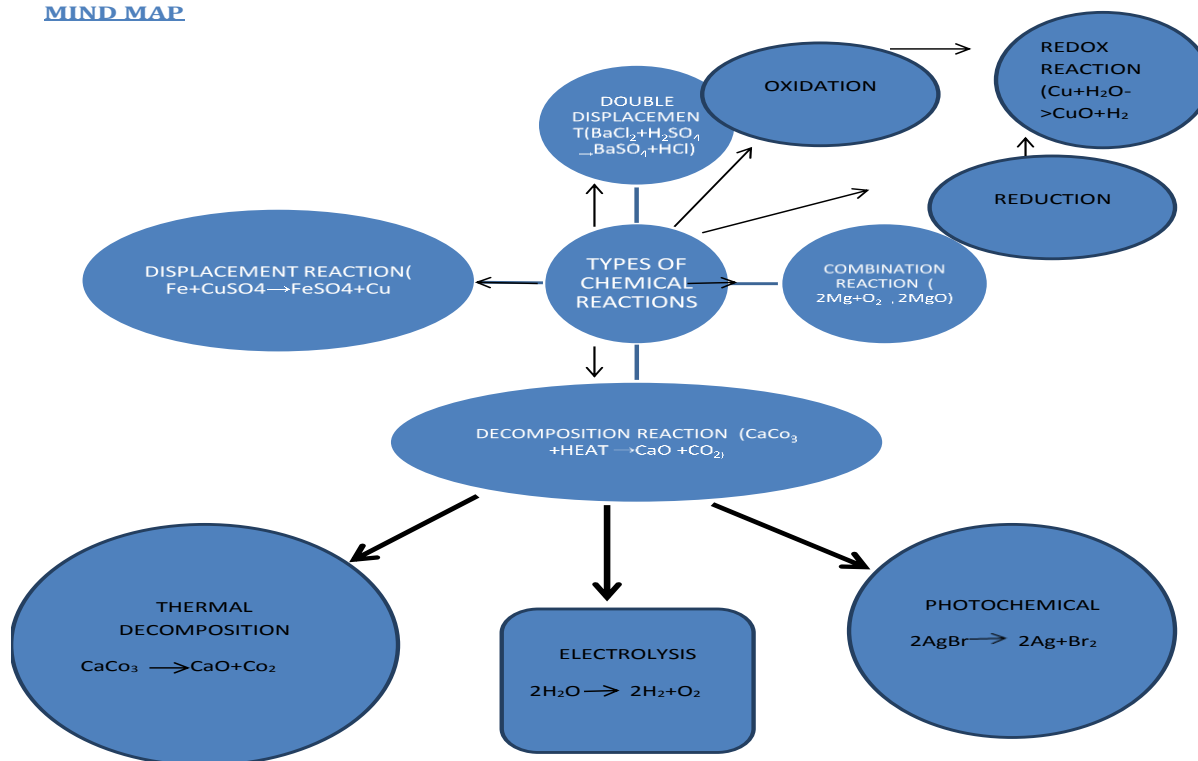

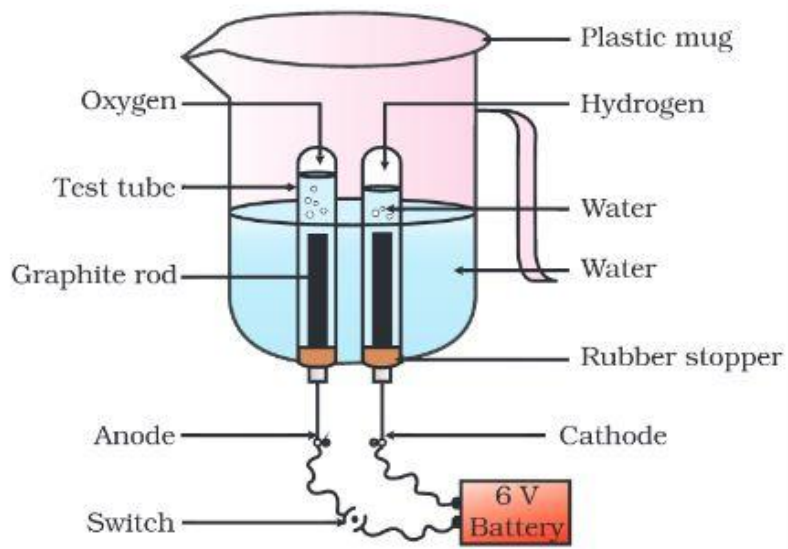

CROSSWORD

Complete the crossword belowput the correct word

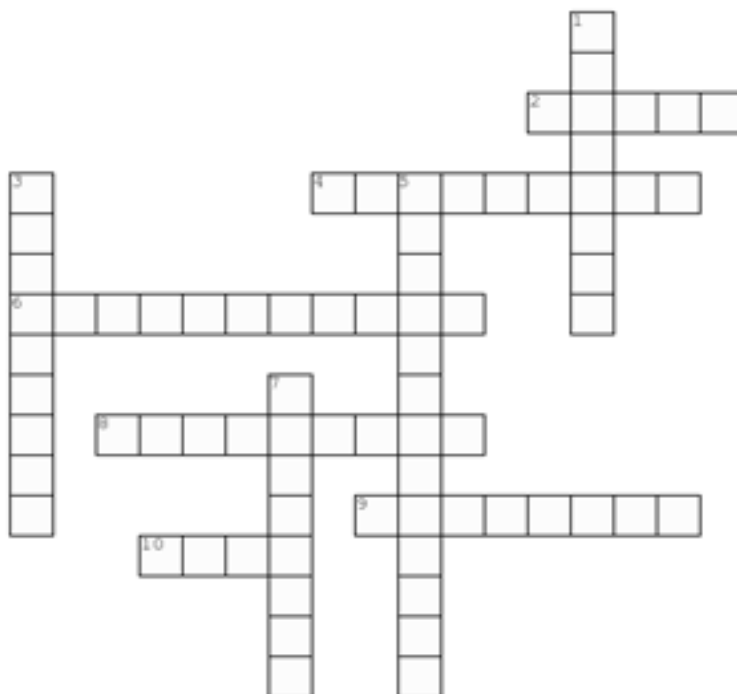

Created with TheTeachersCorner.net [Crossword Puzzle Generator](http://www.theteacherscorner.net)

Across

- 2. Both oxidation and reduction take place
- 4. Process of loss of oxygen
- 6. Reaction of two elements combined together to get a single product
- 8. Process of gain of oxygen
- 9. What does iron do when placed in copper sulphate solution
- 10. Metal extensively used in industries and infrastructure

Down

- 1. Change where new substances produced
- 3. when oil foods are kept for long time
- 5. Single compound broken down into two or more products
- 7. All chemical reactions should be ----

Very short answer questions. (1 mark)

1. Identify in the following reaction:

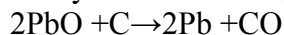

- a) the substance oxidised and
- b) the substance reduced.

2. A shiny brown coloured element “x” on heating in air becomes black in colour . Name the element “x” and the black coloured compound formed.

Ans:Element ‘x’is Copper and the black coloured compound is cupric oxide Cu_2O

Short answer type questions (2 mark)

1. Classify the following reaction as combination,decomposition,displacement and double displacement reaction:-

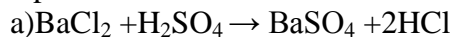

Ans: Double displacement reaction.

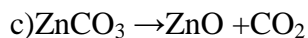
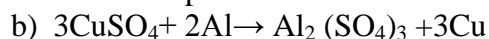

Ans: Decomposition reaction

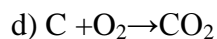

B

2) What is a precipitation reaction? Give an example.

Ans. Reaction in which an insoluble substance or precipitate is formed $\text{Na}_2 + \text{BaCl}_2 \rightarrow \text{BaSO}_4 + 2\text{NaCl}$

Short answer type questions (3 mark)

1. Give an example, each for thermal decomposition and photochemical decomposition reactions. Write balanced equation for the same.

Ans. Thermal decomposition - Heating of lime stone.

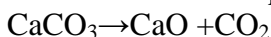

Photochemical decomposition - Action of light on silver bromide.

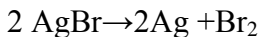

B

VALUE BASED QUESTION

Asmita visited her grandmother during summer holidays. Her grandmother prepared chips for her and stored it in airtight containers.

a) What value is shown by her grandmother?

b) Why did Asmita's grandmother store the snack in airtight container?

Ans: a) Scientific temperament / concern for health

b) To prevent the food items from rancidity.

Very long answer type questions (5 mark)

1. (i) Write chemical equations for the following and balance them.

a) Zinc carbonate(s) \rightarrow Zinc oxide + Carbon dioxide

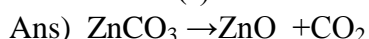

b) Potassium bromide(aq) + Barium iodide(aq) \rightarrow Potassium iodide + Barium bromide.



c) Nitrogen + Hydrogen \rightarrow Ammonia



ii) What happens when electricity is passed through acidified water ?

Decomposition of water takes place resulting in the formation of hydrogen and oxygen.

CHAPTER 2--ACIDS, BASES AND SALTS

Acids: Substances which turn blue litmus solution red are called acids. Acids are sour in taste

Bases: Substances which change red litmus solution blue are called bases. They are bitter in taste.

Mineral Acids: Acids which are obtained from minerals like sulphates, nitrates, chlorides etc. are called mineral acids, e.g., H_2SO_4 (Sulphuric acid), HNO_3 (Nitric acid) and HCl (Hydrochloric acid).

Organic Acids: Acids which are obtained from plants and animals are called organic acids. e.g. citric acid, ascorbic acid, tartaric acid, lactic acid, acetic acid.

Hydronium Ions: They are formed by reaction of H^+ (from acid) and H_2O . It is because H^+ is unstable.

Universal Indicator: A universal indicator is a mixture of indicators which shows a gradual but well-marked series of colour changes over a very wide range of change in concentration of H^+ ion.

Strong Acids: Acids which dissociate into ions completely are called strong acids. Eg. H_2SO_4 , HCl

Weak Acids: Acids which do not dissociate into ions completely are called weak acids Eg.. citric acid, acetic acid.

Chemical properties of acids

(i) Acids react with active metals to give salt and hydrogen gas.

(ii) Acids react with metal carbonate and metals hydrogen carbonate to give salt, water and carbon dioxide.

(iii) Acids react with bases to give salt and water. This reaction is called neutralization reaction.

(iv) Acids react with metals oxides to give salt and water.

Chemical properties of Bases

(i) Reaction with Metals – Certain metals such as Zinc, Aluminium and Tin react with alkali solutions on heating and hydrogen gas is evolved

(ii) Reaction with acids – Bases react with acids to form salt and water.

Indicators - Indicators are substances which indicate the acidic or basic nature of the solution by their colour change.

pH scale : A scale for measuring hydrogen ion concentration in a solution.

The pH of a solution is defined as the negative logarithm of hydrogen ion concentration in moles per litre.

$$\text{pH} = -\log [\text{H}^+]$$

$$\text{pH} = -\log [\text{H}_3\text{O}^+]$$

where $[\text{H}^+]$ or $[\text{H}_3\text{O}^+]$ represents concentrations of hydrogen ions in solution.

The pH of a neutral solution is 7

The pH of an acidic solution is < 7

The pH of a basic solution is > 7

Some Important Compounds and their uses

Common Name	Chemical name	Chemical formula	Uses
Washing soda	Sodium carbonate decahydrate	$\text{Na}_2\text{CO}_3 \cdot 10\text{H}_2\text{O}$	Manufacture of borax, caustic soda, softening of hard water
Baking soda	Sodium hydrogen carbonate	NaHCO_3	Used as antacid, ingredient of baking powder
Bleaching powder	Calcium oxychloride	CaOCl_2	Bleaching clothes, used as oxidizing agent, disinfecting water, manufacture of chloroform
Plaster of Paris	Calcium sulphate hemihydrate	$\text{CaSO}_4 \cdot 1/2\text{H}_2\text{O}$	Plastering fractured bones, making toys, decorative materials, statues

EQUATIONS OF ACIDS, BASES AND SALTS

Acid + Metal \rightarrow Salt + Hydrogen gas



Base + Metal \rightarrow Salt + Hydrogen gas



(Sodium zincate)

Base + Acid \rightarrow Salt + Water

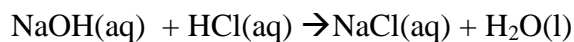

Acids give hydronium ions in water



Bases generate OH^- ions in water



Reactions Of Important chemical compounds

Preparation of Bleaching powder

By the action of chlorine on dry slaked lime

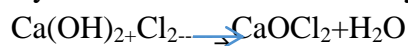

On heating, baking soda liberates CO_2



Washing soda(Sodium carbonatedecahydrate)

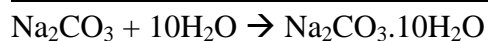

Plaster of Paris

Preparation of plaster of Paris



On mixing plaster of Paris with water, gypsum is obtained

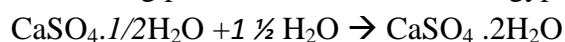

MIND MAP

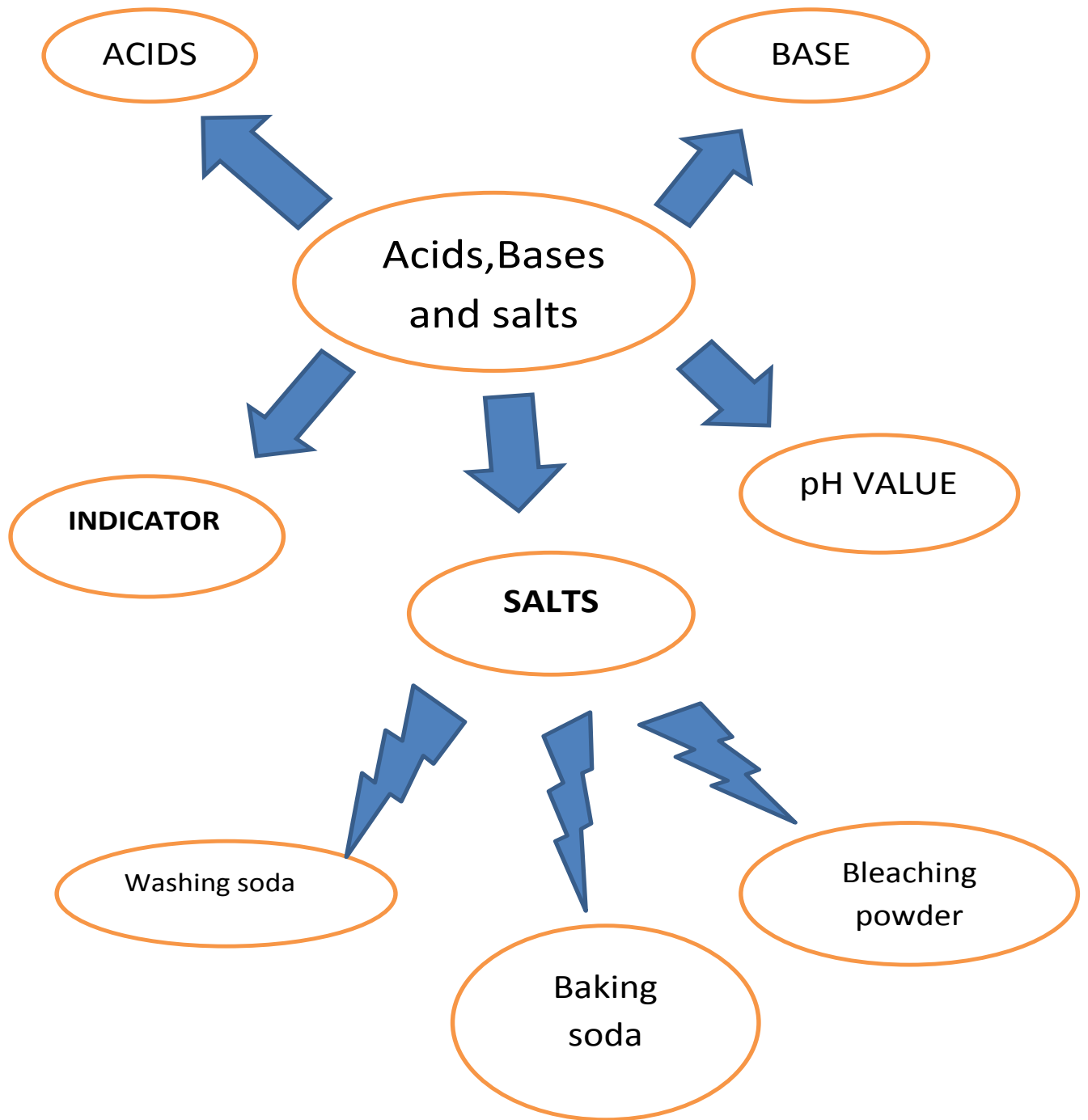

QUESTION BANK

Very Short Answer Type Questions(1mark)

1. Write the name of the products formed by heating gypsum at 373K. Write one use of it. Plaster of Paris and water. It is used for plastering fractured bone.
2. Write the chemical name and formula of the compound which is used as an antacid. Sodium bicarbonate, NaHCO_3

Short Answer Type Questions(2mark)

1. Given below are the pH values of different liquids. 7.0, 14.0, 4.0, and 2.0. Which of these could be that of a) lemon juice b) distilled water c) sodium hydroxide solution d) tomato juice.
2. What is baking powder? How does it make the cake soft and spongy? Baking powder is a mixture of sodium hydrogen carbonate and tartaric acid. On heating it liberates CO_2 which makes the cake soft and spongy

Short Answer Type Questions(3mark)

1. Write the chemical name of Plaster of Paris. Write a chemical equation to show the reaction between Plaster of Paris and water. Name the compound produced in this reaction.

Calcium Sulphate hemihydrate.

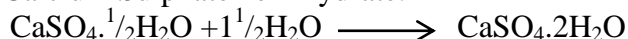

The compound produced is Gypsum.

2. A gas X reacts with lime water and forms a compound Y which is used as bleaching agent in the chemical industry. Identify X and Y. Give the chemical equation of the reaction involved.

X is chlorine Y is CaOCl_2 (calcium oxy chloride) used as bleaching agent.

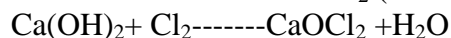

Long answer type questions (5 mark)

1. a) A milk man adds a very small amount of baking soda to fresh milk. Why does he shift the pH of the fresh milk from 6 to slightly alkaline?
b) Mention pH range within which our body works?
c) Explain how antacids give relief from acidity.
d) Mention the nature of tooth pastes. How do they prevent tooth decay?
 - a) It is done to prevent the formation of lactic acid which spoils the milk
 - b) pH range 7.0- 7.8
- c) Antacids neutralizes excess of acid in our body and gives relief.
 - d) Basic. Neutralize the acid formed in the mouth
2. a) Crystals of a substance changed their color on heating in a closed test tube but regained it after some time when they were allowed to cool down. Name the substance and write its formula. Explain the phenomenon.
 - b) How is sodium carbonate prepared? Give two uses of the compound
- a) Copper sulphate, $\text{CuSO}_4 \cdot 5\text{H}_2\text{O}$.
It is blue. It becomes white on heating due to loss of water molecule.
$$\text{CuSO}_4 \cdot 5\text{H}_2\text{O} \xrightarrow{\text{Heat}} \text{CuSO}_4 + 5\text{H}_2\text{O}$$

It regains its colour by absorbing water from atmosphere
$$\text{CuSO}_4 + 5\text{H}_2\text{O} \xrightarrow{\text{Heat}} \text{CuSO}_4 \cdot 5\text{H}_2\text{O}$$
 - b) Prepared by passing CO_2 through ammoniacal brine
Used for production of washing powder & manufacture of glass

CHAPTER 3 : METALS AND NON-METALS

MIND MAP

PHYSICAL PROPERTIES 📌		
	METAL	NON-METALS
LUSTRE	LUSTROUS	NON-LUSTROUS
HARDNESS	HARD	BRITTLE
MALLEABILITY	MALLEABLE	NON-MALLEABLE
DUCTILITY	DUCTILE	NON-DUCTILE
CONDUCTIVITY	GOOD CONDUCTOR OF HEAT AND ELECTRICITY	BAD CONDUCTOR OF HEAT AND ELECTRICITY
PHYSICAL STATE	GENERALLY SOLID	SOLID, LIQUID OR GAS
SONOROUS	MAKES SOUND WHEN STRUCK	DOES NOT MAKES SOUND WHEN STRUCK
MELTING AND BOILING POINT	HIGH MELTING POINT AND BOILING POINT	LOW MELTING POINT AND BOILING POINT

Exceptional properties
of metals and non-metals

1. Mercury (Metal) is liquid at room temperature
2. Iodine (Non-metal) is lustrous
3. Diamond (Carbon, non-metal) is the hardest substance
4. Graphite (Carbon, Non-metal) is a good conductor of electricity
5. Sodium and potassium (Metals) can be cut with a knife
6. Gallium and caesium (Metals) melt when kept on palm (Low M.P)

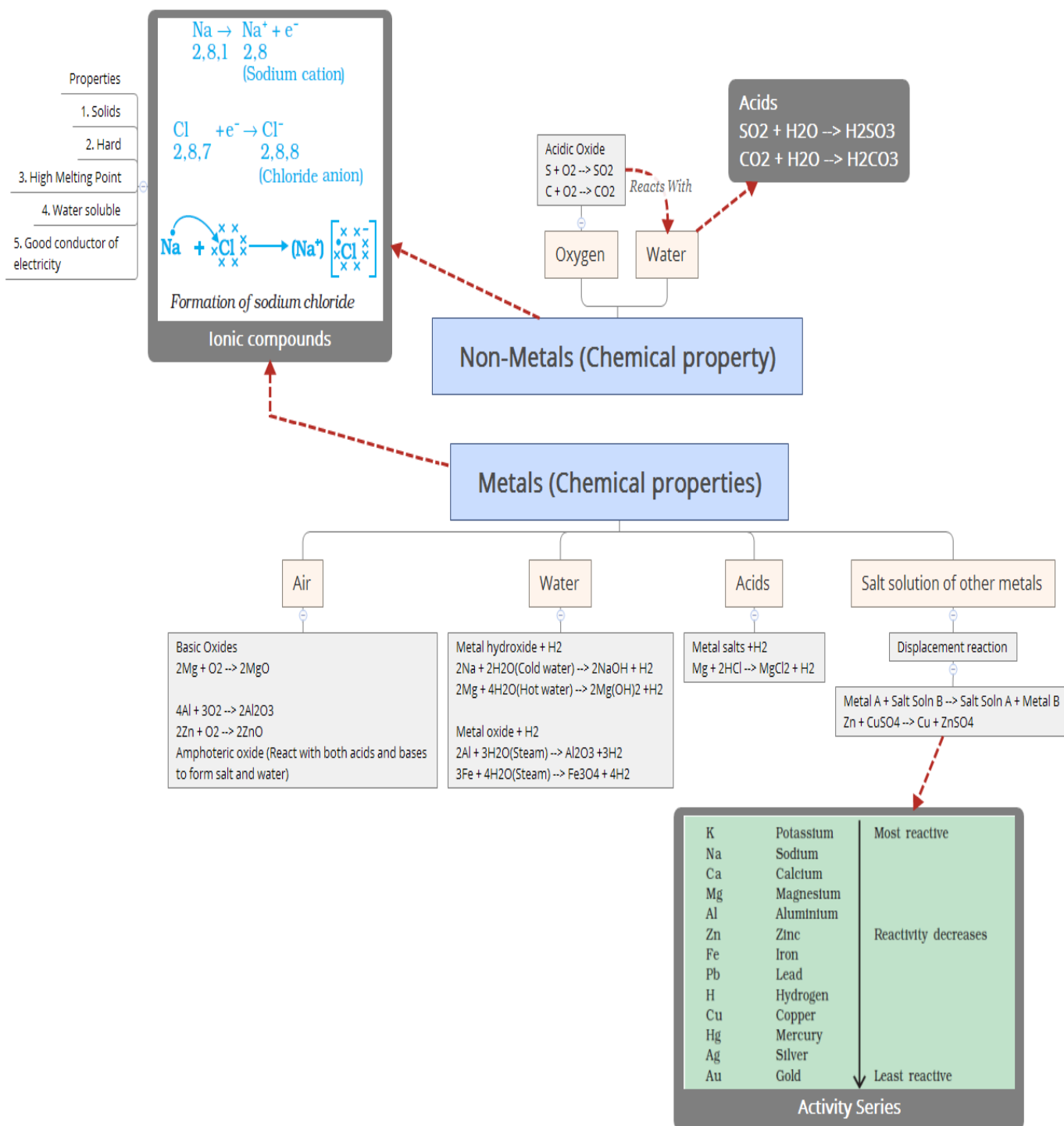

EXTRACTION OF METALS

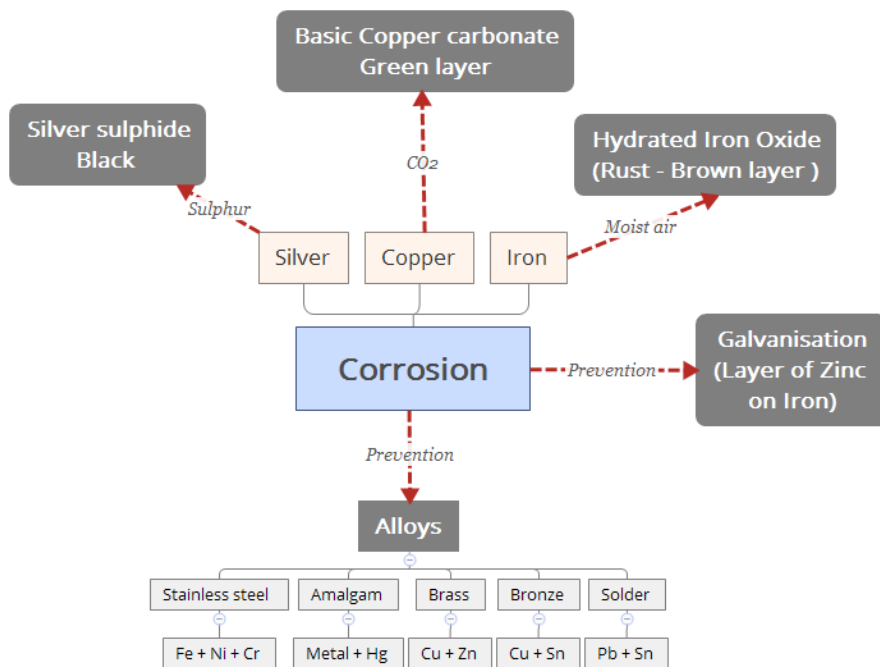
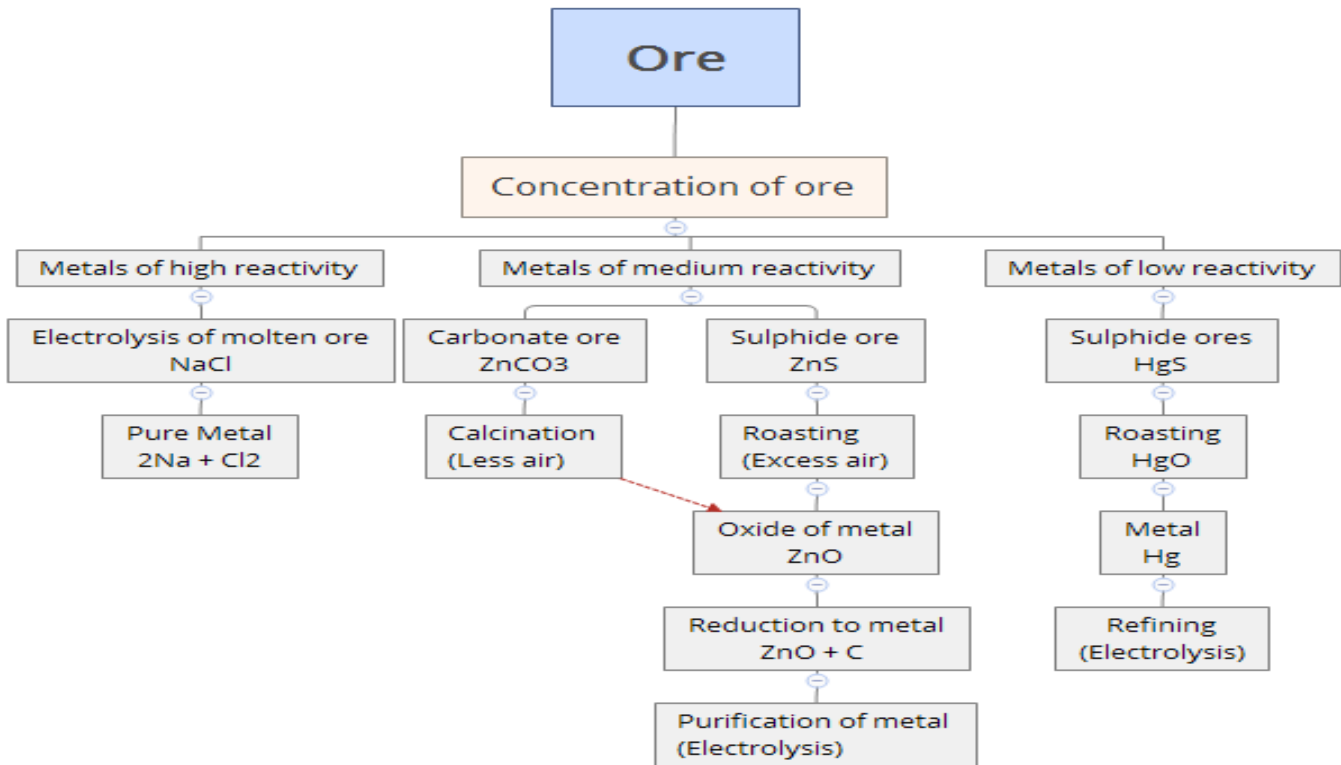

DIAGRAM

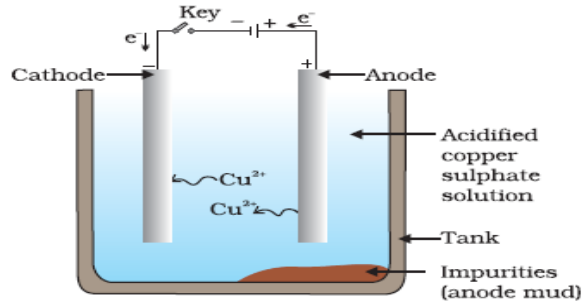
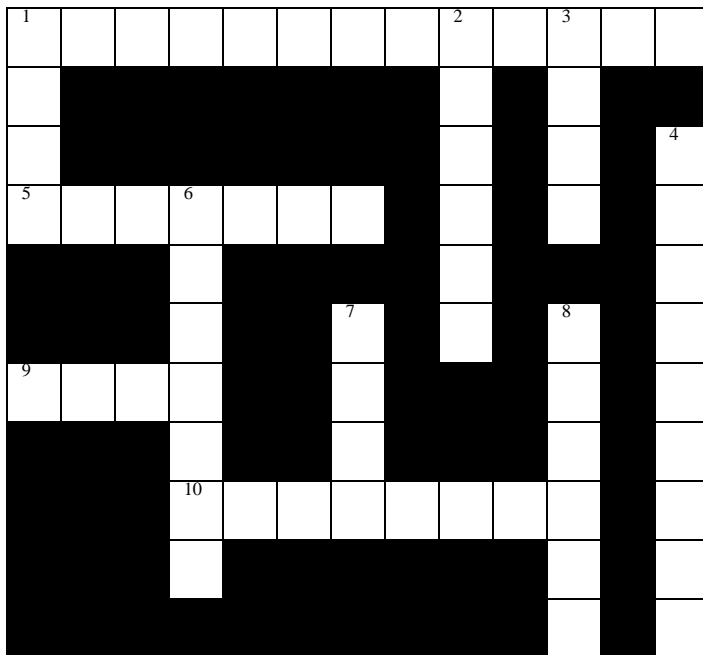

Figure 3.1
Electrolytic refining of copper. The electrolyte is a solution of acidified copper sulphate. The anode is impure copper, whereas, the cathode is a strip of pure copper. On passing electric current, pure copper is deposited on the cathode.

CROSSWORD



Across

- 1 Protecting Iron
- 5 Hardest Substance
- 9 Forms amphoteric oxide
- 10 Sulphide Ores

Down

- 1 Most ductile metal
- 2 Homogenous mixture of metals
- 3 A Metal which gets rusted
- 4 Burns with dazzling white flame
- 6 Liquid at room temperature
- 7 Minerals from which metal is extracted
- 8 Impurity in ore

QUESTION BANK

VERY SHORT ANSWER TYPE (1 MARK)

1. Differentiate between the oxides of magnesium and sulphur.
2. Name one metal which is a poor conductor of heat

SHORT ANSWER TYPE (2 MARK)

1. Give Reasons
 - a. Sodium and potassium are stored in kerosene
 - b. Ionic compounds have higher melting point
2. Differentiate between metals and non-metals based on
 - a. Malleability
 - b. Electrical conductivity

SHORT ANSWER TYPE (3 MARK)

1. Show the formation of magnesium chloride with the help of electron dot structure
2. What happens when
 - a. Zinc reacts with copper sulphate solution
 - b. Aluminium reacts with steam
 - c. Sodium reacts with water

Give balanced reactions for each.

VALUE BASED QUESTION

Anita bought silver jewellery along with her friend Rita. Anita advised Rita to make sure that the jewellery was kept in a sealed box and not exposed to air; but Rita forgot and left it open. After some months when Rita decided to wear it, she found the jewellery all black. Rita was very upset.

- a. Why did the jewellery become black when exposed to air?
- b. What is this process called?
- c. What were the values shown by Anita?

LONG ANSWER TYPE (5 MARK)

1. With the help of labelled diagram explain how copper metal is purified after extraction
2. Explain
 - a. How is zinc obtained from sulphide and carbonate ores? Differentiate between the two giving chemical reactions
 - b. What are the advantages of alloys? Name the constituents of bronze.

CHAPTER 6 : LIFE PROCESSES

MIND MAP

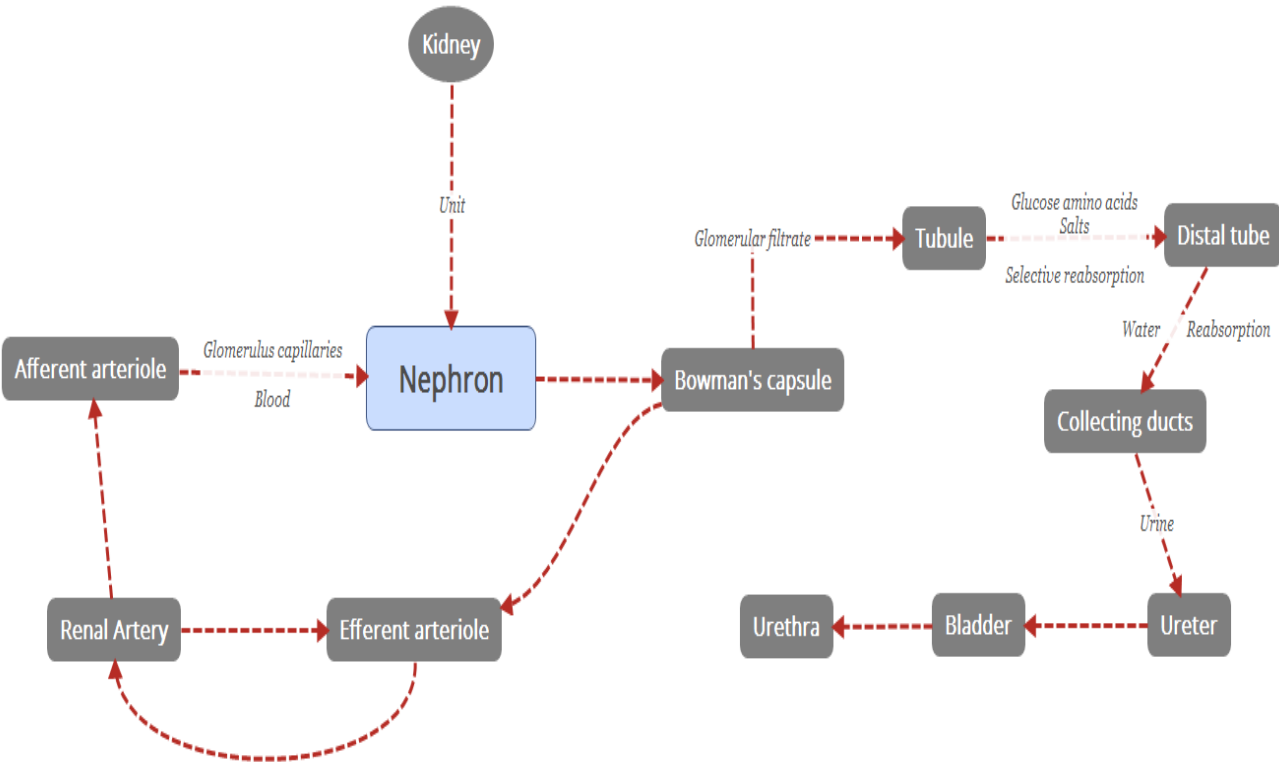
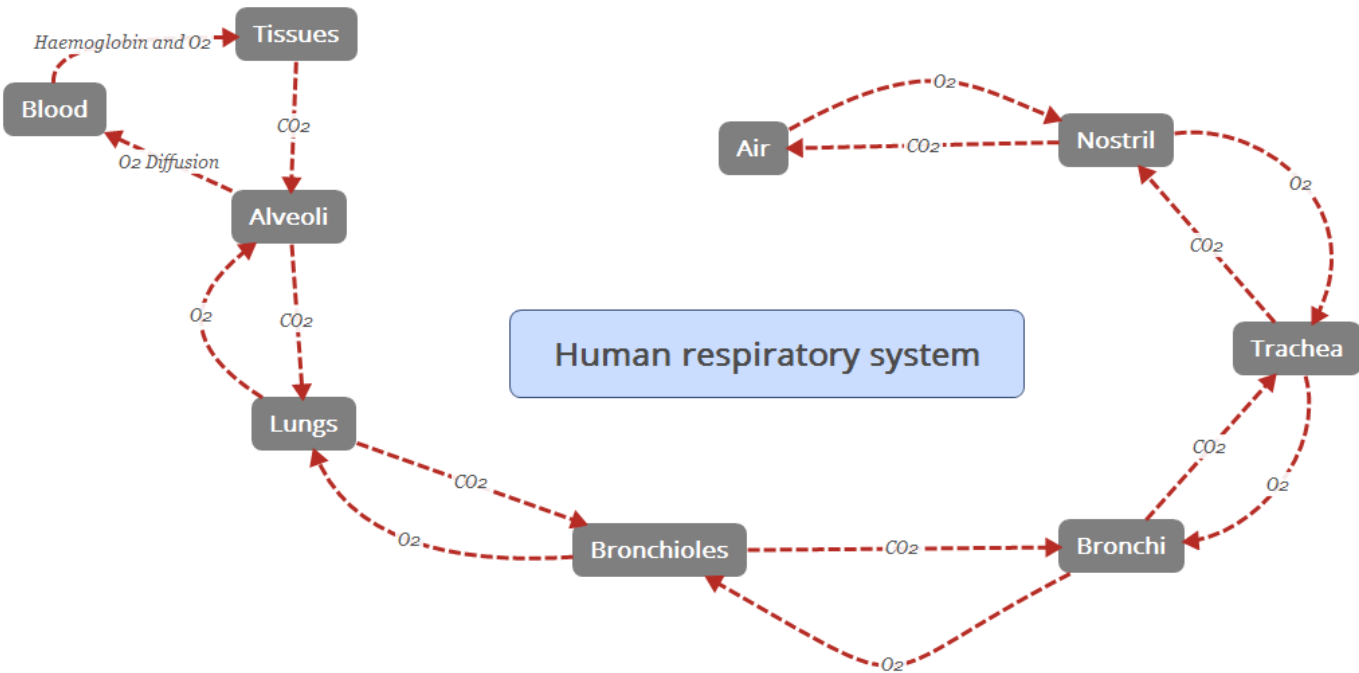

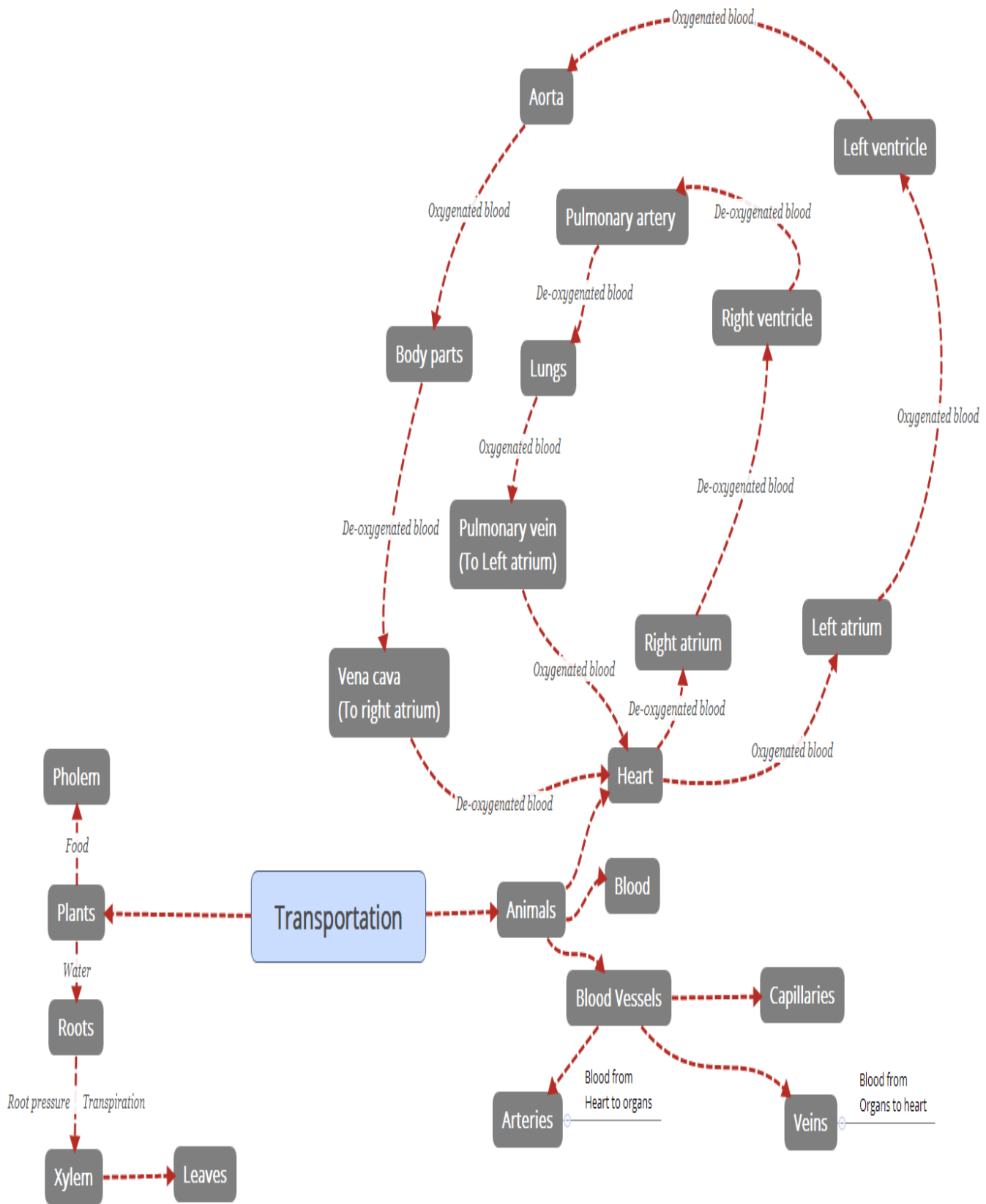

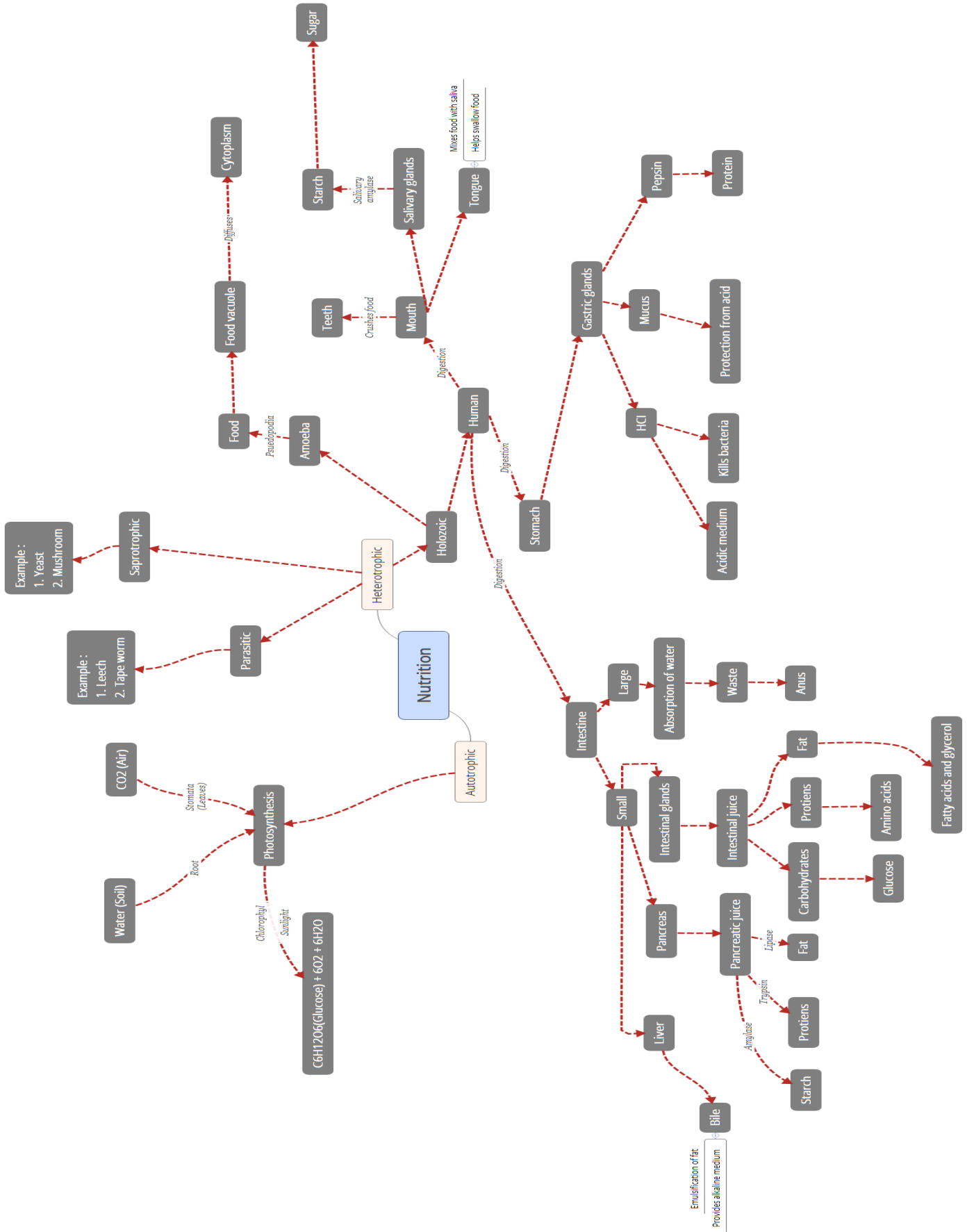

DIAGRAMS

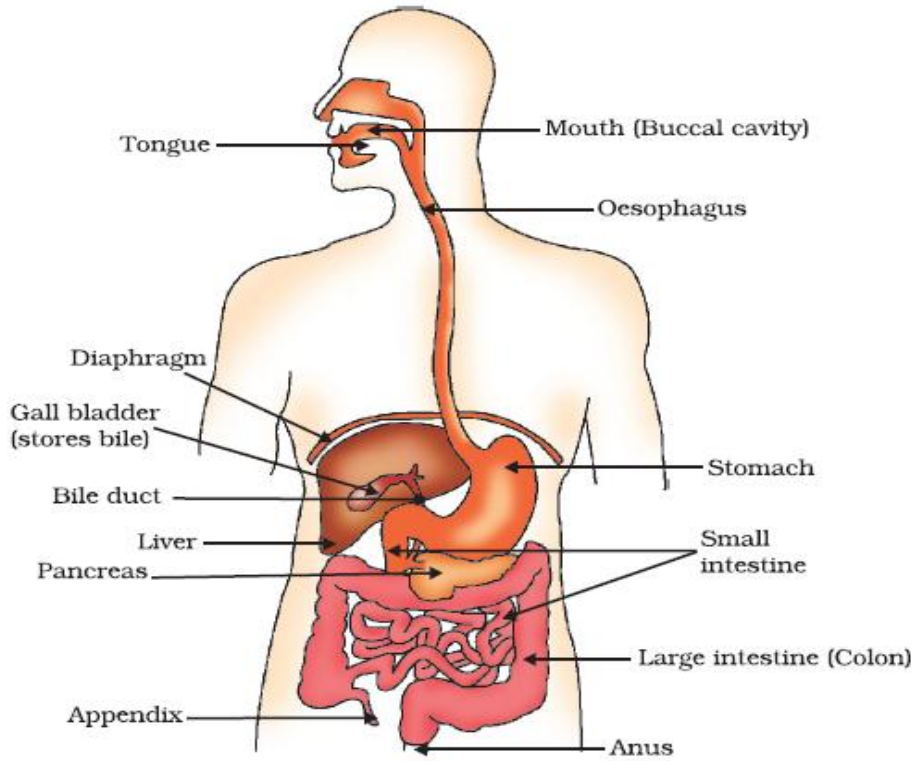

Figure 6.1 Human alimentary canal

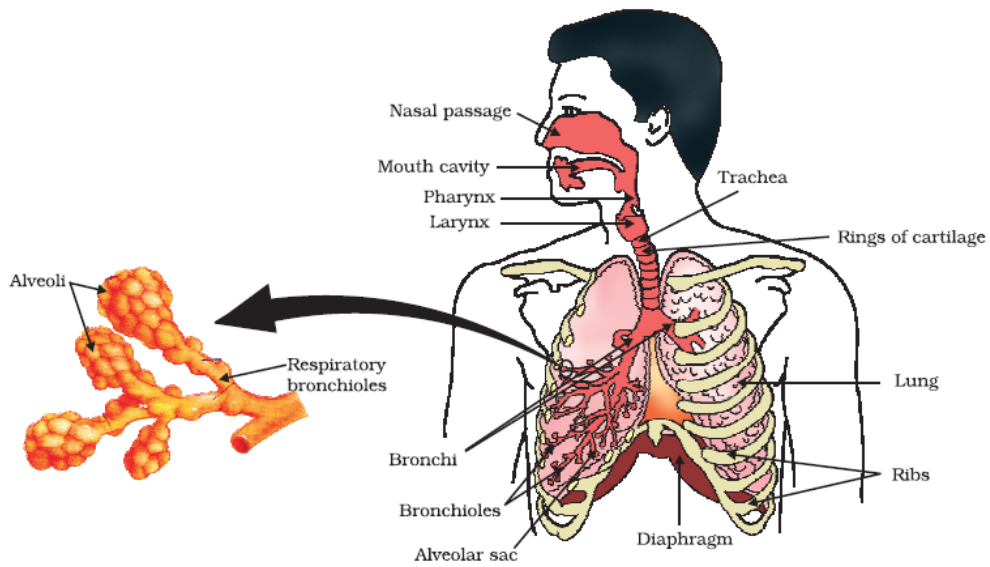

Figure 6.2 Human respiratory system

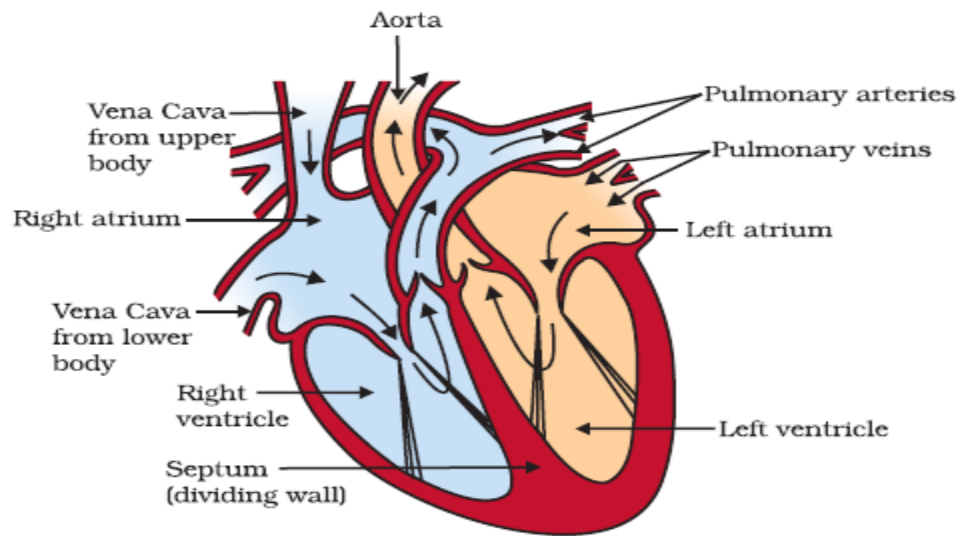

Figure 6.3
Sectional view of the human heart

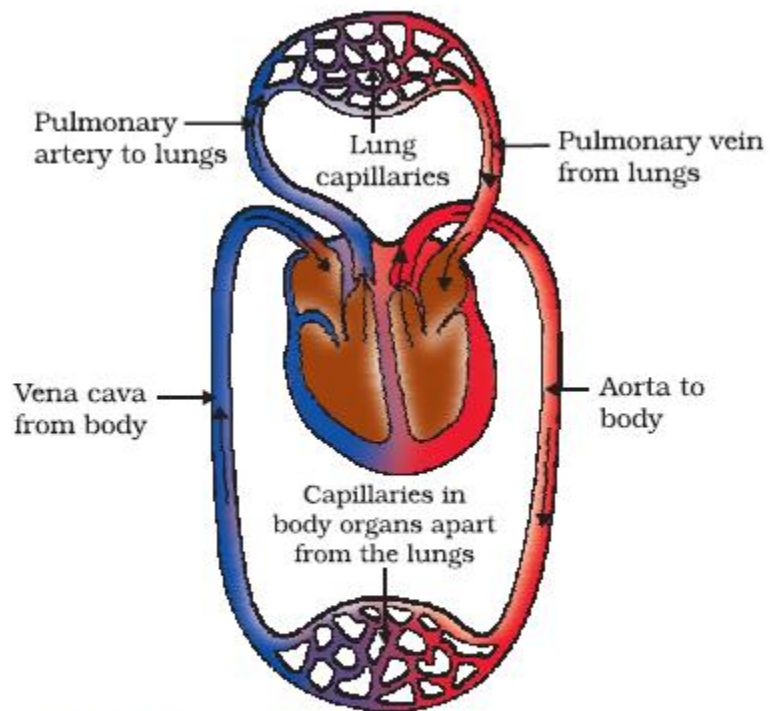

Figure 6.4
Schematic representation of transport and exchange of oxygen and carbon dioxide

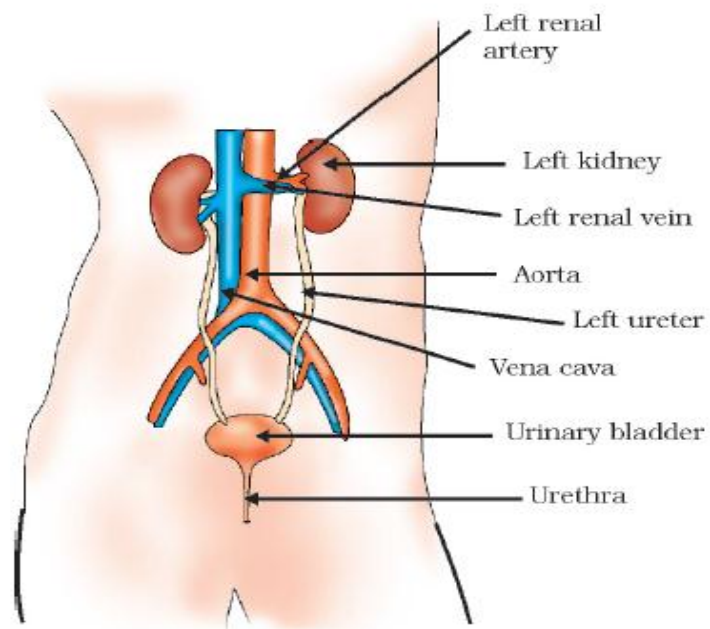

Figure 6.5
Excretory system in human beings

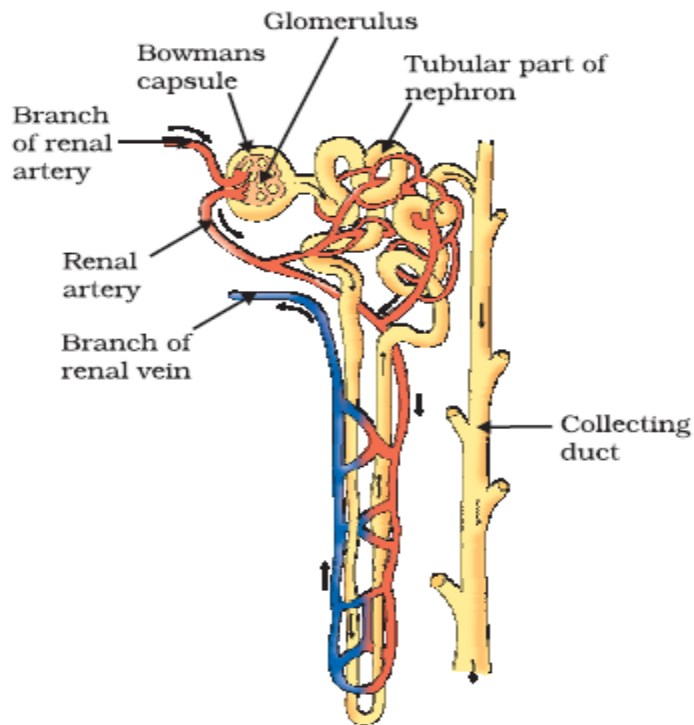
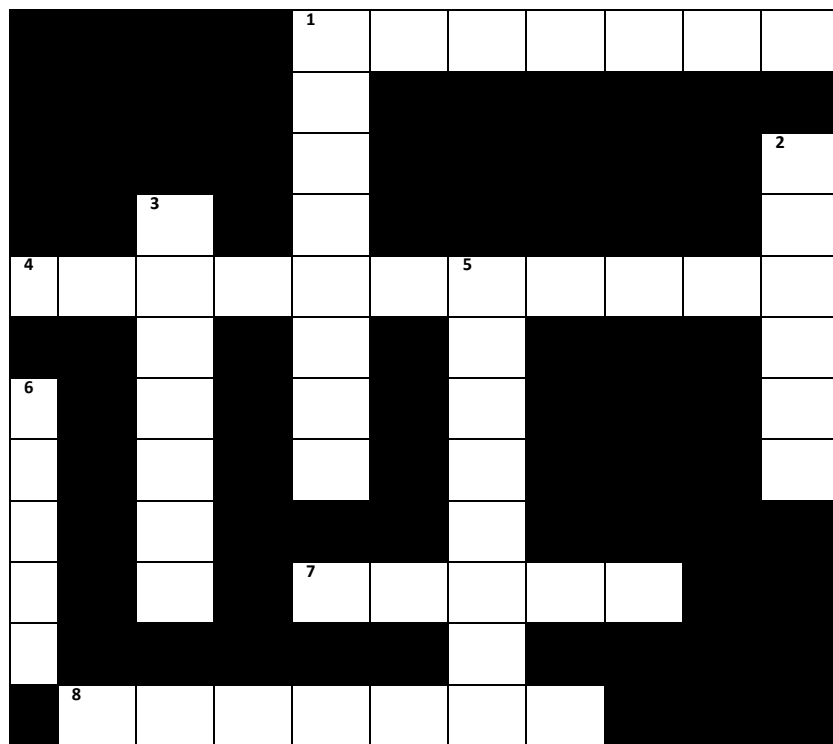

Figure 6.6
Structure of a nephron

CROSSWORD



ACROSS

1. Balloon like structures in the lungs
4. Green pigment in plants
7. Helps in absorption of food
8. Involved in exchange of gases in plants

DOWN

1. Carries oxygenated blood
2. Prevents backflow of blood
3. End product of carbohydrate digestion
5. Helps in clotting of blood
6. Pumps blood to all parts of the body

QUESTION BANK

VERY SHORT ANSWER TYPE (1 MARK)

1. Which tissue transports soluble products of photosynthesis?
Ans: Phloem
2. What is the role of saliva in digestion of food?
Ans: Digests starch

SHORT ANSWER TYPE (2 MARK)

1. Differentiate between blood and lymph
Hint: Colour, presence of RBC, direction of flow
2. What is the advantage of a four chambered heart in humans?
Separates oxygenated and deoxygenated blood

3. Give twopoints of difference between arteries and veins
Hint: Direction of flow, oxygenated/deoxygenated blood, thick/thin wall

SHORT ANSWER TYPE (3 MARK)

- d. Bile (*Emulsifies fat*)
- e. Hydrochloric acid (*Kills bacteria/acidic medium*)
- f. Villi (*absorption of food*)

2. Complete the following :

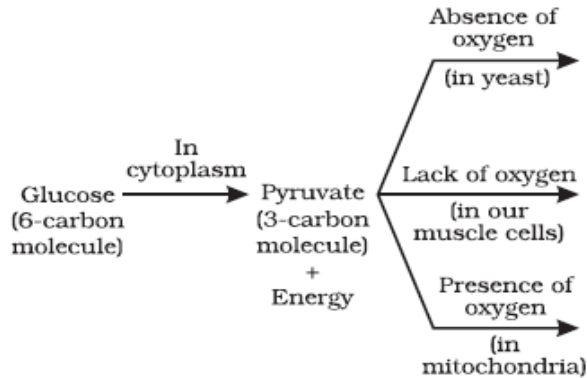

- a) *Ethanol and carbon dioxide*
- b) *Lactic acid*
- c) *Carbon dioxide and water*

3. Write the difference between aerobic and anaerobic respiration?

Aerobic respiration	Anaerobic respiration
1. Takes place in presence of Oxygen.	1. Takes place in absence of Oxygen.
2. End products- Carbon dioxide & Water	2. End products- Ethanol & Carbon dioxide
3. More energy is released. (38ATP)	3. Less energy is released. (2ATP)
4. Takes place in Cytoplasm & Mitochondria	4. Takes place only in Cytoplasm.
5. Complete oxidation of glucose takes place.	5. Incomplete oxidation of glucose takes place.

4.

5. VALUE BASED QUESTION

Anil was walking in the park when he saw the man next to him collapse suddenly. He rushed him to the hospital where the doctor checked him and told him that he collapsed due to low blood pressure.

- a) What is blood pressure and how is it measured?
Pressure exerted by blood on the arterial wall/sphygmomanometer
- b) What is normal systolic and diastolic pressure?
120/80 mm of Hg
- c) What values are shown by Anil?
Love, caring, presence of mind

LONG ANSWER TYPE (5 MARK)

- 1. What is double circulation? What is its advantage? Show with labelled diagram.
Hint: Blood flows through the heart in one cycle, separation of oxygenated/deoxygenated blood
- 2. How is urine produced? How is it regulated?
Hint: Filtration, selective reabsorption; Amount of water, with hormonal regulation

MULTIPLE CHOICE QUESTIONS

1. The photosynthetic pigments are located in-

- a) Chloroplasts
- b) leucoplast
- c) nucleus
- d) ribosomes

2. To show that light is necessary for photosynthesis a science teacher told Raman to cover a leaf with a thick black paper. The reason behind this can be

- a) To destarch the leaf
- b) to prevent the light from entering the leaf
- c) to decolourise the leaf
- d) to turn leaf blue black

3. It is essential to boil the destarched leaf in alcohol using a water bath because –

- a) Alcohol is highly volatile
- b) steam from the water bath helps in dissolving chlorophyll
- c) alcohol is inflammable
- d) steam from the water bath helps in softening the leaf

4. Stomata are more in number on the -

- a) Upper side of the leaf
- b) lower side of the leaf
- c) same on both the sides
- d) margins of the leaf

5. In the experiment to show that CO₂ is released during respiration the partial vacuum is created because –

- a) Germinating seeds release CO₂
- b) germinating seeds utilize CO₂

c) KOH absorbs CO_2 d) KOH absorbs O_2 . 6. While preparing a 6. temporary stained mount of a leaf epidermal peel the extra stain is removed by -

- a) Washing with water
- b) Washing with calcium chloride
- c) Soaking with filter paper
- d) Absorbing by cotton wool

CHAPTER 7-CONTROL AND COORDINATION

Stimulus:-The change in the environment to which an organism respond and react is called stimulus.

Control & co-ordination in animals takes place by :-a) Nervous system) Hormonal system (Endocrine glands)

Parts of Nervous system:-a) Brain b) Spinal cord c) Nerves

Neuron:-Is the structural and functional unit of Nervous system

Parts of Neuron:-a) Dendrites, b) cell body c) Axon

Synapse:-Junction between two adjacent nerves

Reflex action- spontaneous, involuntary and automatic response to a stimulus to protect us from harmful situations. E.g. On touching a hot objects unknowingly we instantly withdraw our hand.

Nervous system-(1) Central Nervous System (CNS)

(2) Peripheral Nervous System (PNS)

(i) Autonomic Nervous System (ii) Voluntary Nervous System

Brain (i) Centre of coordination of all activities (ii) Thinking is involved (iii) Complex process

Parts of Brain- Refer to figure 7.3 page no. 118 of N.C.E.R.T Textbook

Fore brain Cerebrum - (i) Main thinking and largest part of the brain.

(ii) It has 3 main areas-

- a. Sensory area- to receive impulses from sense organs via Receptors
- b. Motor area- control voluntary movements
- c. Association areas- Reasoning, learning & intelligence.

Thalamus- It relays sensory information to the cerebrum.

Hypothalamus- It forms the link between Nervous system & Endocrine system

Mid brain- It connects fore brain and hind brain

Hind Brain- connects the fore brain and hind brain

Cerebellum- controls & coordinates muscular movements, maintaining body posture and equilibrium.

Pons- acts as a bridge between brain and spinal cord

Medulla Oblongata- Controls involuntary actions like blood pressure, salivation, vomiting etc.

Spinal cord: - cylindrical or tubular structure is extending downwards from the medulla oblongata.

Protection of the brain & the spinal cord-

- (i) Bony outer covering: skull for the brain and vertebral column for the spinal cord.
- (ii) Cerebrospinal fluid present in between the three membranes.
- (iii) do not take part in the reaction & are destroyed immediately.

Important Endocrine glands, the hormone they secrete & their function

Refer to figure 7.7 page no. 124 of N.C.E.R.T text book

Coordination in plants- only chemical coordination is present in plants.

Tropic movements- the movements of plants in the direction of stimulus (positive) or away from it (negative) are called tropic movements. E.g. Phototropism, Geotropism, Chemotropism.

Refer to figure 7.4 & 7.5 page no. 121 of N.C.E.R.T text book

Plant hormones (Phytohormones)

Important Endocrine glands, the hormone they secrete & their function

Refer to figure 7.7 page no. 124 of N.C.E.R.T text book

No.	GLAND	HORMONES	FUNCTION	TARGET SITE
1.	Hypothalamus	i) Releaser hormones (RH) ii) Inhibiting hormones	-Regulates secretion of pituitary hormones.	Pituitary gland
2.	Pituitary Gland	i) Growth hormone (GH)	-Controls growth- dwarfism & gigantism.	-Most tissues
4.	Thyroid Gland	i) Thyroxin ii) Triiodothyronine iii) Thyrocalcitonin (TCT)	-Basal metabolic rate, RBC formation. -Regulates Ca level.	-Body tissues
7.	Adrenal Gland	i) Adrenaline ii) Noradrenalin iii) Corticoids	-Increase alertness, pupillary dilation, piloerection, sweating, and heart beat.	-Body tissues
8.	Pancreas	i) Insulin	-regulates glucose homeostasis, stimulates glycogenesis, controls carbohydrate mellitus	-Tissues
		ii) Glucagon	-maintains glucose levels, stimulates gluconeogenesis. -release of sugar from liver.	
9.	Testis	i) Testosterone ii) Androgens	-develops male reproductive organs & accessory sexual characters. -influence male sexual behavior.	-Male body tissues
10.	Ovary	i) Estrogen	- develops female reproductive organs, accessory sexual characters & female secondary behavior.	-Female body tissues
		ii) Progesterone	-supports pregnancy, stimulates milk secretion.	

MIND MAP

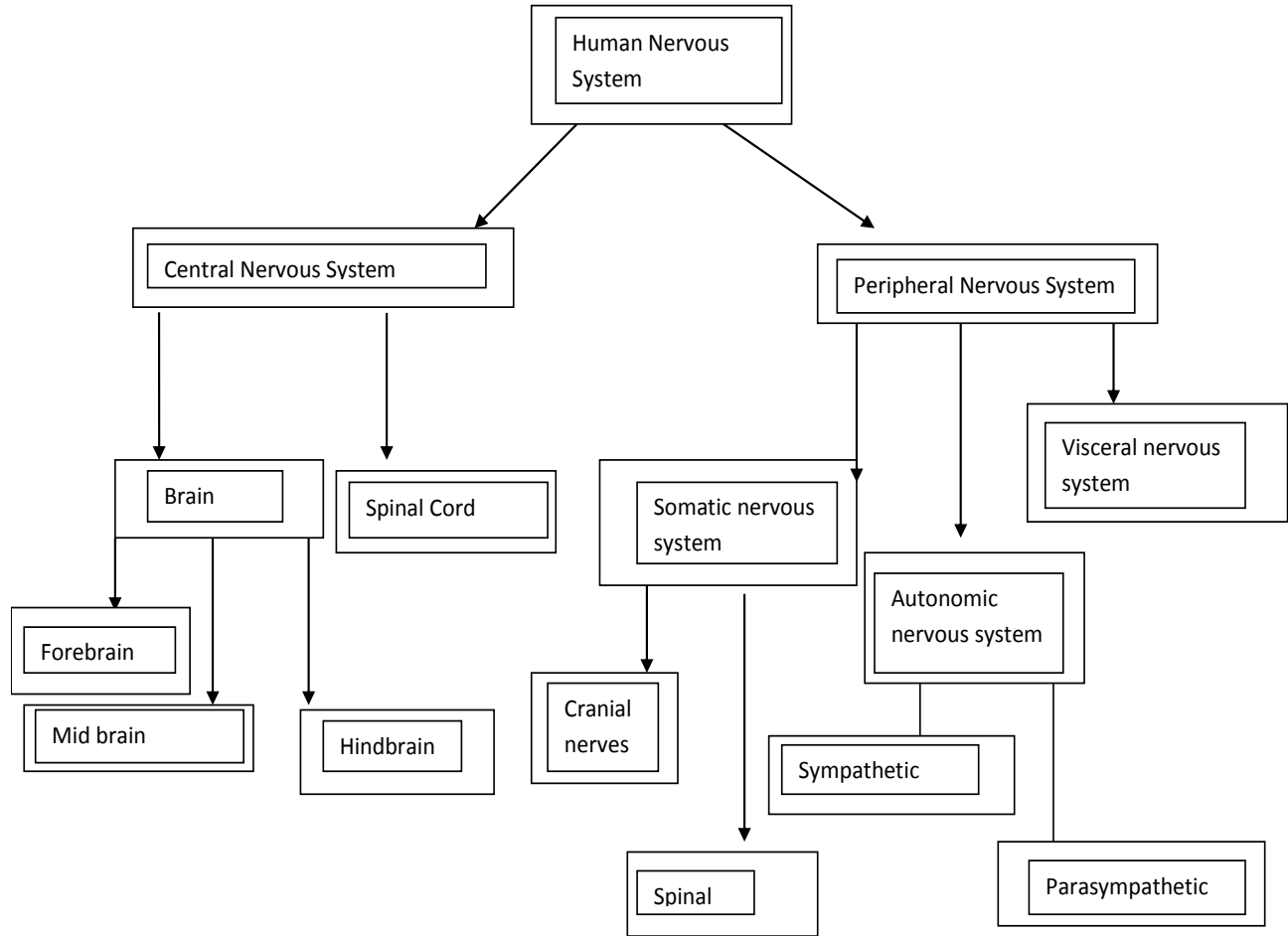

DIAGRAMS

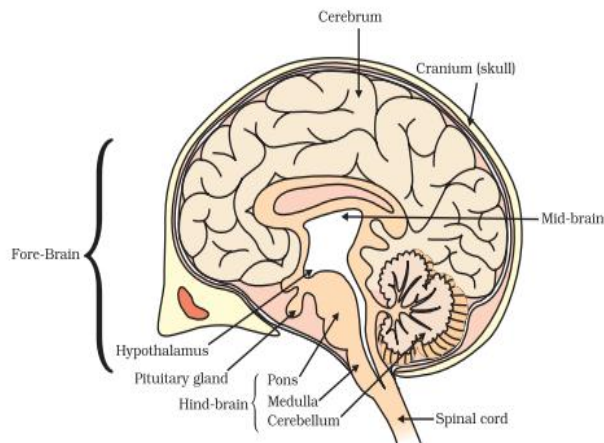
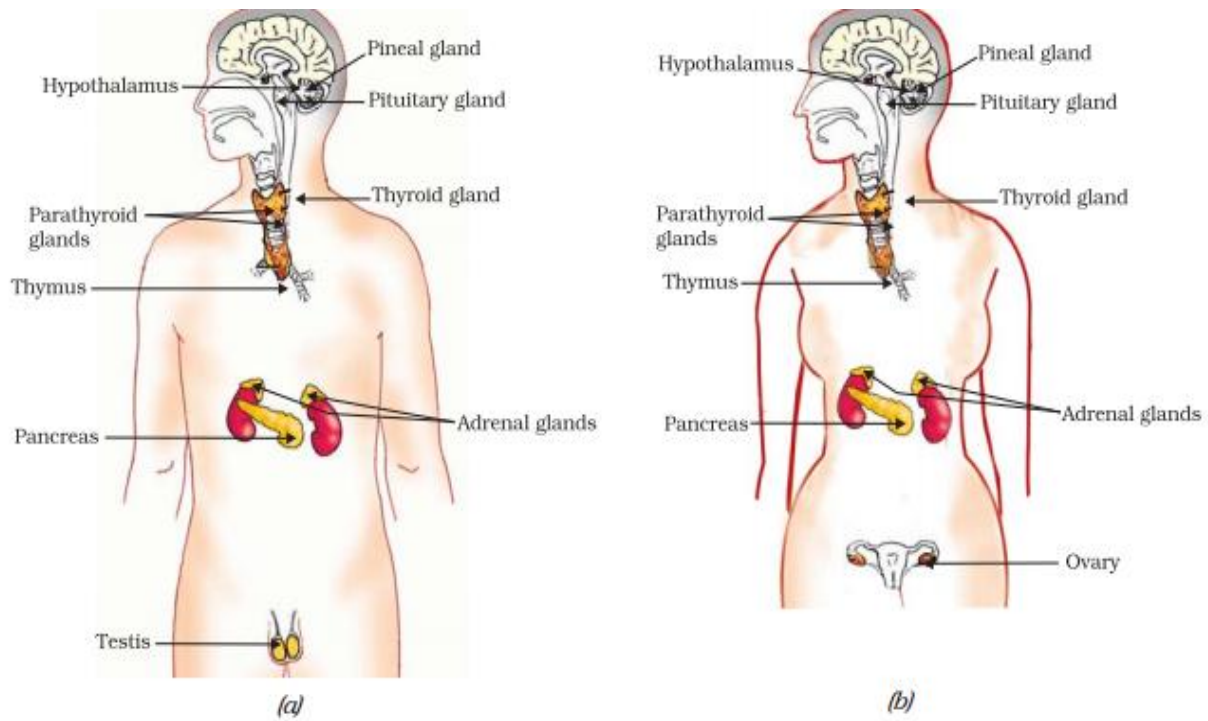
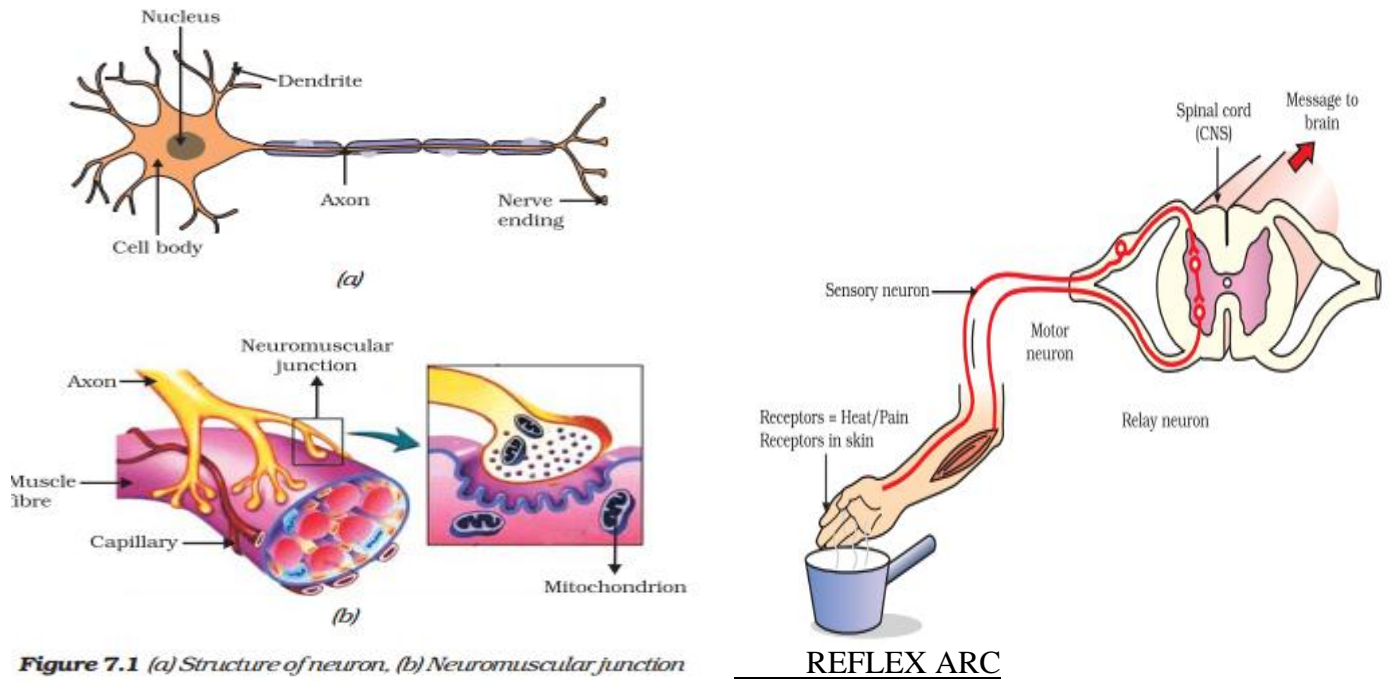

Figure 7.3 Human brain



QUESTION BANK

VERY SHORT ANSWER TYPE QUESTIONS

1. Name the hormone which helps in regulating sugar level in our blood? Name the gland which secretes this hormone?
2. State the main function of abscisic acid
3. Write name of three hormones secreted by the pituitary gland
4. Mention one example of chemotropism.

(SHORT ANSWER TYPE QUESTIONS) 2 MARK

1. Name the following:
 - a) Necessary for thyroid glands
 - b) Necessary to maintain sugar level of the body
- 2) Draw the diagram of a nerve cell and label the following on it: (a) Nucleus (b) Dendrites
- 3) How does our body maintain blood sugar level?

SHORT ANSWER QUESTIONS (3 MARK)

1. A compound of iodine is compulsorily added to common salt in small quantity.
 - (a) Why is it important for us to have iodised salt in our diet.
 - (b) Name the disease caused by its deficiency.
 - (c) Write the symptoms of the disease.
2. What is reflex action? Describe the steps involved in reflex action.
- 3) Name the following:

Response of plants to light, chemical and water.

VALUE BASED QUESTION

Ritesh is fond of eating pickles. As he hears the name of pickles, watering starts in his mouth. His friends used to make fun of him. When the same process or event was executed to the dog of Ritesh, the result was different. Now answer the following questions:

- (i) What is the biological term for the watering of Ritesh in his mouth?
- (ii) Why did the dog of Ritesh not water from mouth in the same events?
- (iii) What is the value shown by his friends?

LONG ANSWER QUESTIONS (5 Mark)

1. Name the plant growth hormone which is synthesized at the shoot tip. Explain briefly why a plant bends towards light during its growth.
2. Draw the diagram of human brain and label the parts. Write the function of cerebellum and pons
3. What is reflex action? Describe the steps involved in reflex action.
- 4) Name the following:

Response of plants to light, chemical and water.

CHAPTER12 : ELECTRICITY

MIND MAPS

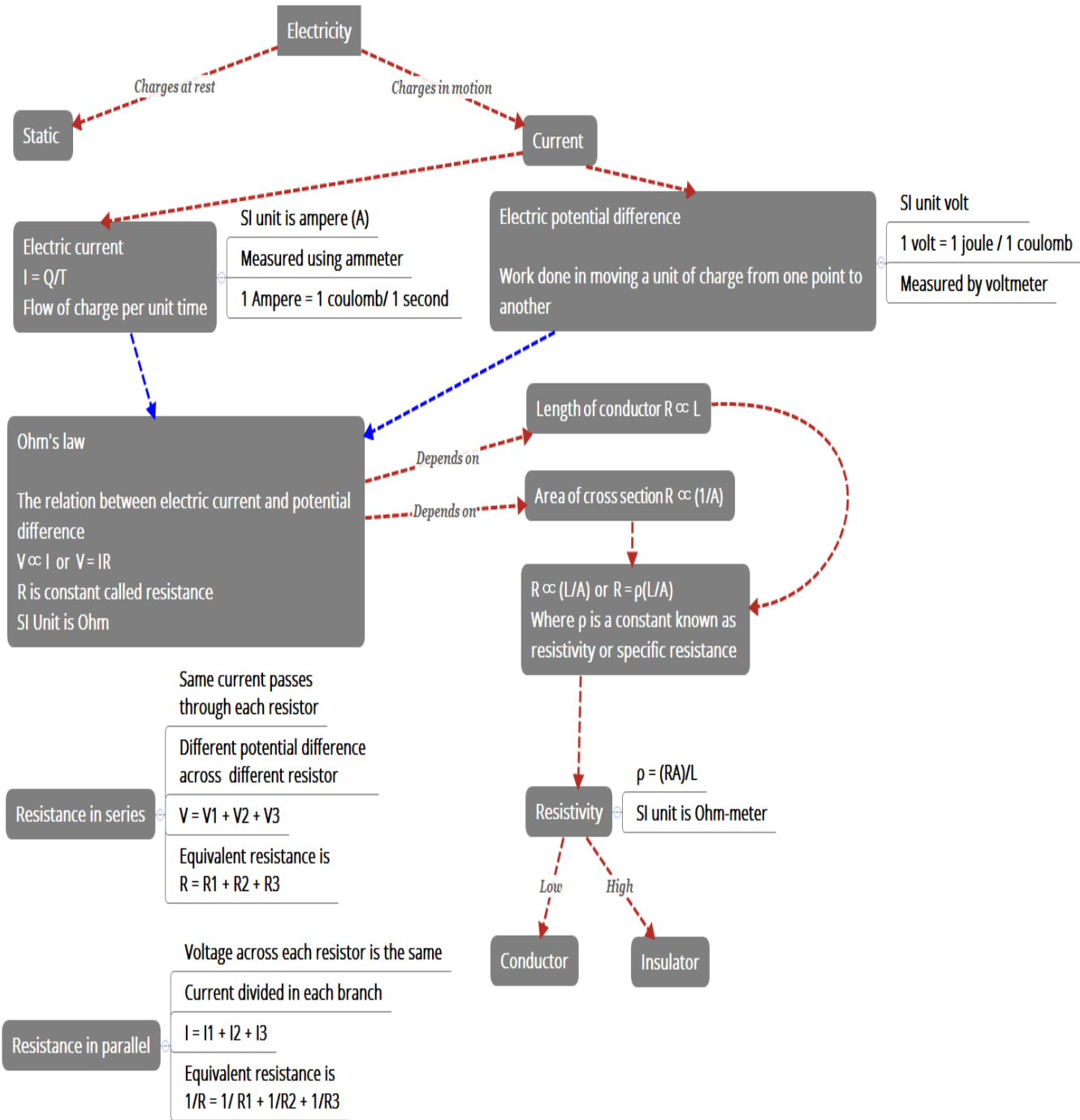

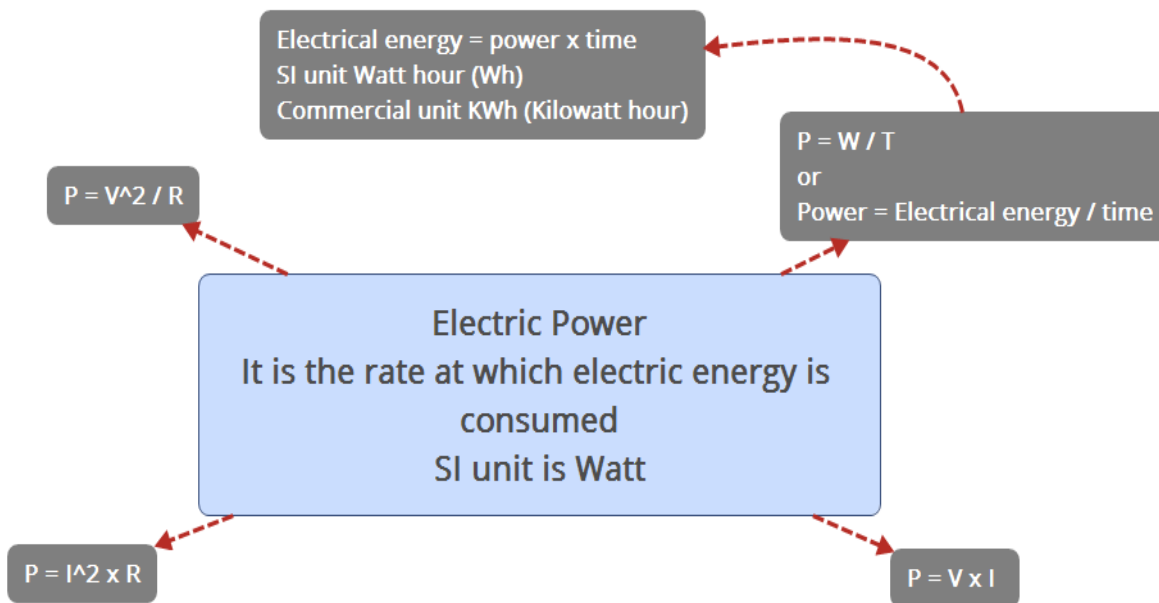

1KWh = 1 unit

1 KWh = 3.6×10^6 joule

HEATING EFFECT OF CURRENT

Joule's law of heating

$H = I^2RT$ (**I = Current, R = Resistance, T = Time**)

PRACTICAL APPLICATIONS OF HEATING EFFECT

1. Examples of devices which work on this effect
 - a. Toaster
 - b. Oven
 - c. Heating iron
 - d. Heater
2. Electric bulb produces light due to this effect by heating up tungsten (Tungsten is the filament in the bulb). It has a high melting point and is covered by a glass bulb. Inert atmosphere is provided by filling the bulb with nitrogen or argon (Inert gases)
3. Fuse (Used in electric circuits) works on this effect

FORMULAE

		<u>SI unit</u>
1.	$I = Q/T$ (Calculation of current)	Ampere
2.	$V = W/Q$ (Calculation of potential difference)	Volt
3.	$V = IR$ (Ohm's law, R is resistance)	Ohm
4.	$\rho = RA/L$ (Calculation of resistivity)	Ohm metre
5.	$R = R_1 + R_2 + R_3$ (Resistance in series)	Ohm
6.	$R = 1/R_1 + 1/R_2 + 1/R_3$ (Resistance in parallel)	Ohm
7.	$H = I^2RT$ (Joules law of heating)	Joule
8.	$P = VI = I^2R = V^2/R$ (Calculation of power)	Watt
9.	$E = P \times t$ (Electric energy)	Watt second (Joule)

DIAGRAMS

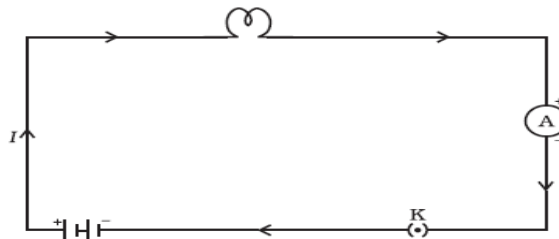

Figure 12.1
A schematic diagram of an electric circuit comprising - cell, electric bulb, ammeter and plug key

Table 12.2 Symbols of some commonly used components in circuit diagrams

Sl. No.	Components	Symbols
1	An electric cell	
2	A battery or a combination of cells	
3	Plug key or switch (open)	
4	Plug key or switch (closed)	
5	A wire joint	
6	Wires crossing without joining	
7	Electric bulb	
8	A resistor of resistance R	
9	Variable resistance or rheostat	
10	Ammeter	
11	Voltmeter	

ACROSS

- 1 .Rate of flow of charge
- 2 .Ratio of potential difference to the current
- 6 .Rate of consumption of electrical energy
- 7 .SI unit of power

DOWN

- 1 .Closed path for flow of electricity
- 3 .SI unit of electric current
- 4 .SI unit of charge
5. SI unit of potential difference

QUESTION BANK

VERY SHORT ANSWER TYPE (1 MARK)

1. Calculate the amount of charge flowing in a wire if it draws a current of 2A in 10 minutes.
*Ans: $2 \times 10 \times 60$
 $= 1200 \text{ C}$*
2. What happens to resistance of a conductor if area of cross-section is doubled?
Ans: It halves
3. Which device helps to maintain a potential difference across a conductor?
Ans: Cell or battery

SHORT ANSWER TYPE (2 MARK)

1. Draw a circuit diagram having the following components
 - a. Bulb
 - b. A two cell battery
 - c. Ammeter
 - d. A closed key*Ans: Refer diagram 12.1*
2. Why are heating elements made of alloys rather than metals?
Ans: High resistivity, does not oxidise at high temperatures
3. What do we mean when we say that potential difference between two points is 1 volt?
Ans: Definition

SHORT ANSWER TYPE (3 MARK)

1. If three resistors of 6Ω , 9Ω and 21Ω are connected in series to a 12V battery, find
 - a) The total resistance of the circuit.
 - b) The current flowing through the circuit.
 - c) The potential difference across the 21Ω resistor.*Ans. a) 36Ω b) 0.33A c) 6.93V*
2. What are the advantages of connecting electrical devices in parallel with the battery rather than in series?
Ans: (1) The current required by each device is different which is possible only in parallel.
(2) If one device fails others can still work.
(3) Total resistance in the circuit is decreased

VALUE BASED QUESTION

Rohan had gone to Sohan's house for studying. Sohan was worried about the high electricity bill and was wondering how to reduce it. Rohan suggested using LED bulbs instead of fluorescent bulbs as it consumes less electric energy and switch to solar power. After two months when they met again Sohan was very happy as the number of units consumed and the electric bill had reduced drastically.

1. What is electric power? What is its SI unit?
Rate of consumption of electric energy. SI unit is watt
2. What is the commercial unit used to measure electric energy?
KWh
3. What values were shown by Rohan?
Caring, awareness and conservation of energy

LONG ANSWER TYPE (5 MARK)

1.
 - a) What is the function of fuse in an electric circuit?
 - b) What would be the rating of the fuse for an electric kettle which is operated at 220V and consumes 500 W power?
 - c) How is the SI unit of electric energy related to its commercial unit?

*Ans. b) 2.2A flows through the circuit, fuse should be rated 3A.
c) 1 KWh = 3.6 X 10⁶ J*

2.
 - a) State Ohms law. Derive the relation and give graphical representation for it.
 - b) An electric oven rated at 500W is connected to a 220V line and used for 2 hours daily. Calculate the cost of electric energy per month at the rate of Rs.5 per KWh.

Ans. a) $V = IR$, linear equation hence straight line passing through origin

*b) Energy consumed per day = 1 KWh (P x t) cost for 30 days = 1 X 5 X 30 =
Rs.150.00*

CHAPTER 13- MAGNETIC EFFECTS OF ELECTRIC CURRENT

Magnet is an object that attracts objects made of iron, cobalt & nickel.

When a magnet suspended freely it will align in North-South direction. Like poles repel each other and unlike poles attract each other

Magnets are used: (i) In radio & stereo speakers, (ii) In refrigerator doors, (iii) in audio & video cassettes players, (iv) in hard discs & floppies of computers & (v) in children's toys.

Magnetic field: The area around a magnet where a magnetic force is experienced is called a magnetic field. It is a quantity that has both direction & magnitude.

Magnetic field lines: Magnetic field is represented by field lines. They are lines drawn in a Magnetic field along which a unit North magnetic pole moves. Magnetic field lines are called as Magnetic lines of force.

Refer to figure 13.3 & 13.4 page no. 225 of N.C.E.R.T Text book)

Properties of Magnetic field lines:

(i) They do not intersect each other. (ii) It is taken by convention that magnetic field lines emerge from North Pole and merge at the South Pole. Inside the magnet, their direction is from South Pole to North Pole. Therefore magnetic field lines are closed curves.

Magnetic field lines due to a current through a straight conductor (wire)- consist of series of concentric circles whose direction is given by the Right hand thumb rule.

Right hand thumb rule: If a current carrying straight conductor is held in your right hand such that the thumb points towards the direction of current, then the wrapped fingers show the direction of magnetic field lines.

(Refer to figure 13.7, page no. 228 of N.C.E.R.T Text book)

Magnetic field lines due to a current through a circular loop

(Refer to figure 13.8, page no. 228 of N.C.E.R.T Text book)

The strength of the magnetic field at the centre of the loop (coil) depends on:

(i) The radius of the coil- The strength of the magnetic field is inversely proportional to the radius of the coil. If the radius increases, the magnetic strength at the centre decreases. (ii) The number of turns in the coil: As the number of turns in the coil increase, the magnetic strength at the centre increases, because the current in each circular turn is having the same direction, thus the field due to each turn adds up.

(iii) The strength of the current flowing in the coil: as the strength of the current increases, the strength of the magnetic fields also increases.

Solenoid: (Refer to figure 13.10, page no. 229 of N.C.E.R.T Text book)

(i) A coil of many turns of insulated copper wire wrapped in the shape of a cylinder is called a Solenoid.

Magnetic field produced by a Solenoid is similar to a bar magnet.

The strength of magnetic field is proportional to the number of turns & magnitude of current.

Electromagnet: An electromagnet consists of a long coil of insulated copper wire wrapped on a soft iron core. (Refer to figure 13.11, page no. 229 of N.C.E.R.T Text book)

Fleming's Left hand rule: Stretch the thumb, forefinger and middle finger of left hand such that they are mutually perpendicular. Forefinger points in the direction of magnetic field and centre finger in the direction of current, then the thumb gives the direction of force acting on the conductor.

(Refer to figure 13.13, page no. 231 of N.C.E.R.T Text book)

Electric motor: A device that converts electric energy to mechanical energy.

(Refer to figure 13.15, page no. 232 of N.C.E.R.T Text book)

Principle of Electric motor: When a rectangular coil is placed in a magnetic field and a current is passed through it, force acts on the coil, which rotates it continuously. With the rotation of the coil, the shaft attached to it also rotates.

Electromagnetic induction: Electricity production as a result of magnetism (induced current) is called Electromagnetic induction.

Fleming's Right hand rule: gives the direction of induced current.

Stretch the thumb, forefinger and middle finger of right hand such that they are mutually perpendicular. Forefinger points in the direction of magnetic field and centre finger in the direction of induced current, then the thumb gives the direction of motion of the conductor.

Electric generator: A device that converts mechanical energy to electric energy. (Refer to figure 13.19, page no. 236 of N.C.E.R.T Text book)

Electric generator is of two types- (i) A.C generator (ii) D. C generator

Principle of Electric generator: Electromagnetic induction

Domestic electric circuits: (Refer to figure 13.20, page 238 of N.C.E.R.T Text book)

We receive electric supply through mains supported through the poles or cables. In our houses we receive AC electric power of 220V with a frequency of 50Hz.

The 3 wires are as follows- (i) Live wire- (Red insulated, Positive)

(ii) Neutral wire- (Black insulated, Negative) (iii) Earth wire- (Green insulated) for safety measure to ensure that any leakage of current to a metallic body does not give any serious shock to a user.

Short circuit: is caused by touching of live wires and neutral wire

Fuse: is a protective device used for protecting the circuits from short circuiting and over loading

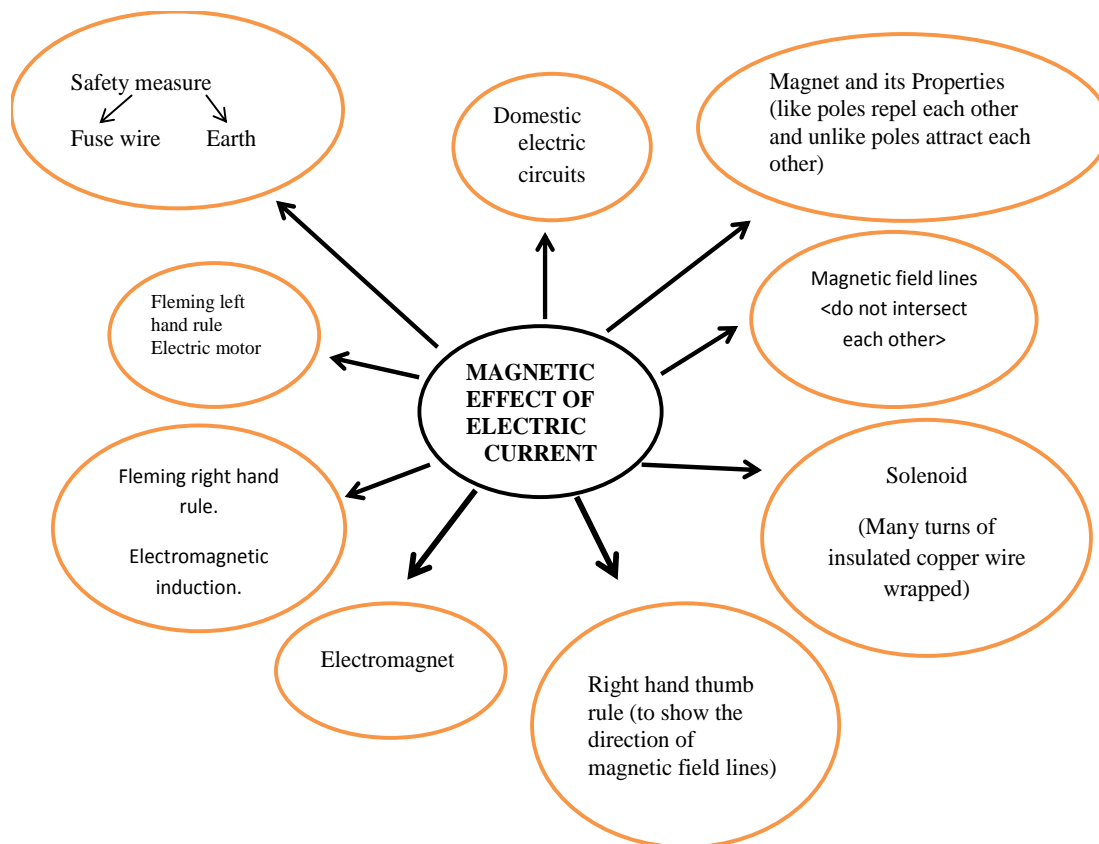

DIAGRAMS

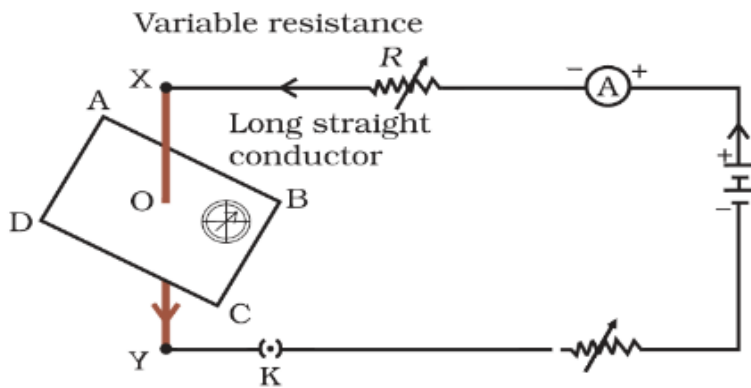

Figure 13.1
Compass needle is deflected on passing an electric current through a metallic conductor

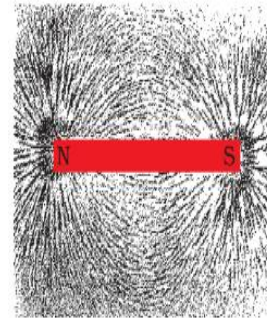

Figure 13.2
Iron filings near the bar magnet align themselves along the field lines.

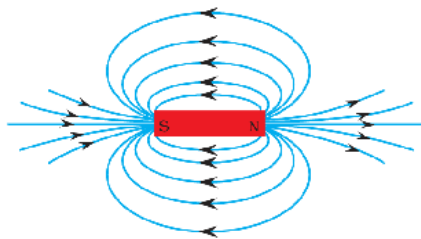

Figure 13.4
Field lines around a bar magnet

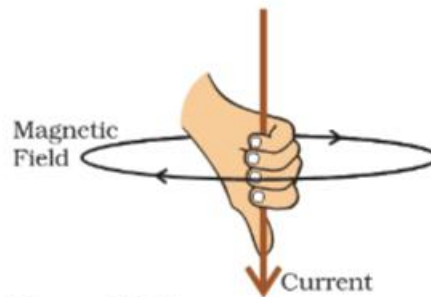

Figure 13.7
Right-hand thumb rule

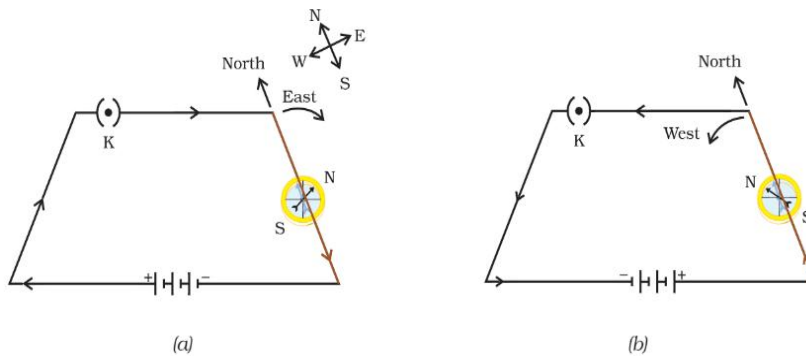

Figure 13.5 A simple electric circuit in which a straight copper wire is placed parallel to and over a compass needle. The deflection in the needle becomes opposite when the direction of the current is reversed.

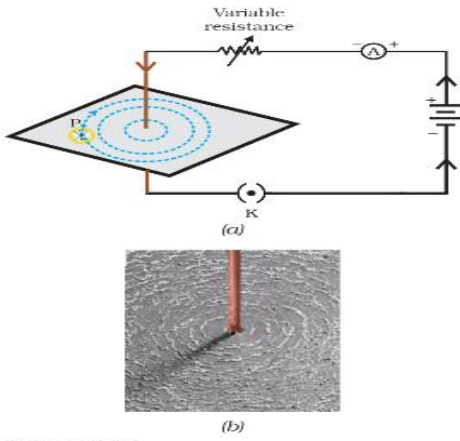

Figure 13.6
 (a) A pattern of concentric circles indicating the field lines of a magnetic field around a straight conducting wire. The arrows in the circles show the direction of the field lines. (b) A close up of the pattern obtained.

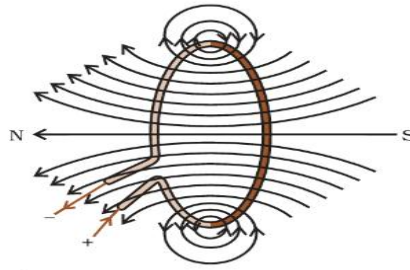

Figure 13.8
 Magnetic field lines of the field produced by a current-carrying circular loop

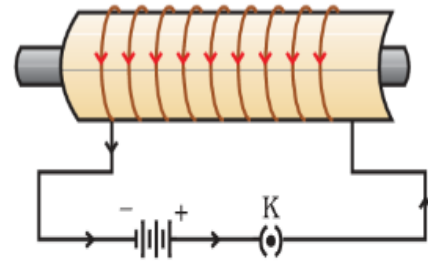

Figure 13.11
 A current-carrying solenoid coil is used to magnetise steel rod inside it - an electromagnet.

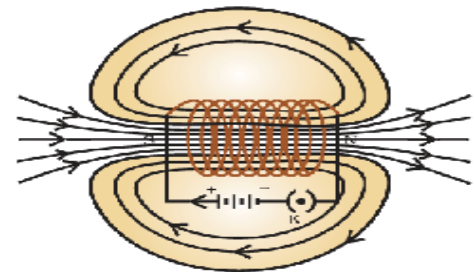

Figure 13.10
 Field lines of the magnetic field through and around a current carrying solenoid.

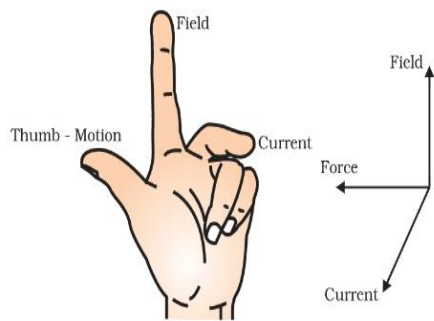

Figure 13.13
Fleming's left-hand rule

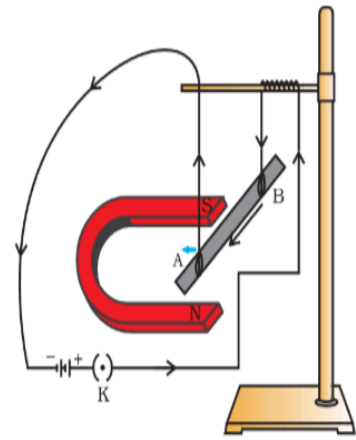

Figure 13.12
A current-carrying rod, AB, experiences a force perpendicular to its length and the magnetic field.

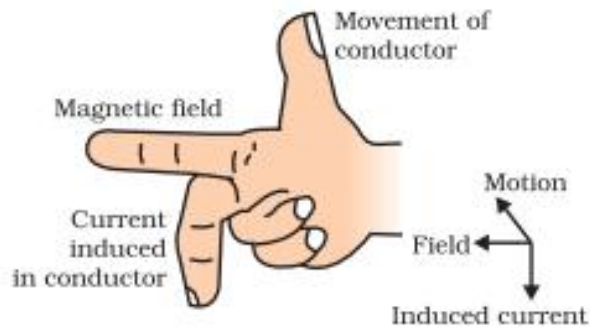

Figure 13.18
Fleming's right-hand rule

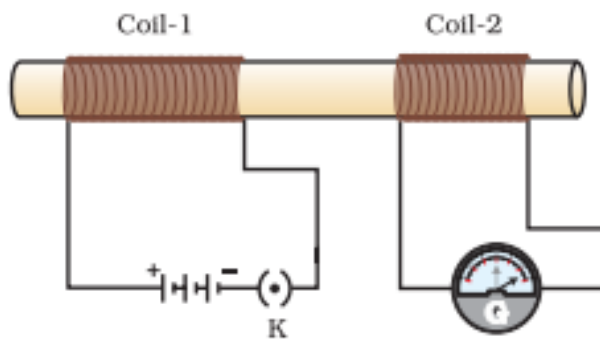

Figure 13.17
Current is induced in coil-2 when current in coil-1 is changed

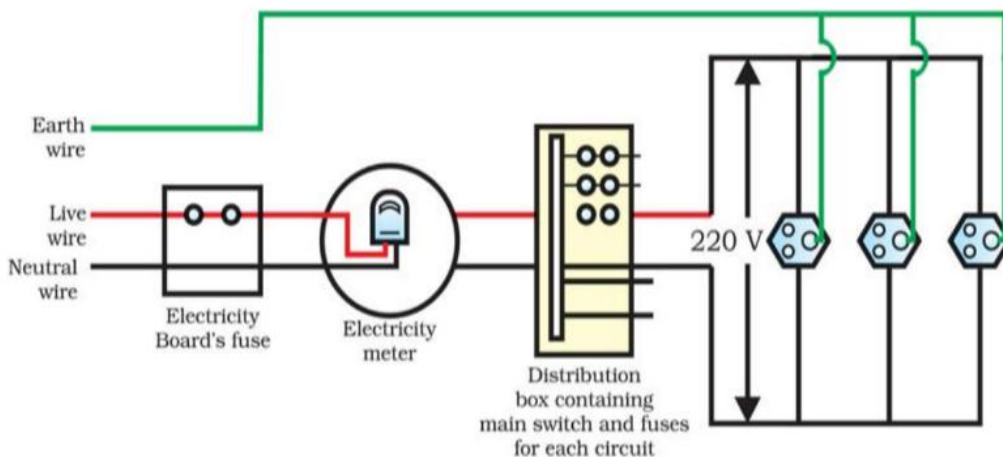

Figure 13.20 A schematic diagram of one of the common domestic circuits

Question Bank

Very Short Answer Type Questions (1mark)

- Q.1 What is a solenoid?
- Q.2 What is the direction of the magnetic field lines inside a bar magnet?
- Q.3 What is the direction of the magnetic field lines outside a bar magnet?

Short Answer Type Questions (2 mark)

- Q.1 What is an electromagnet?
- Q.2 What is the difference between a direct current and an alternating current? What is the frequency of AC in India?
- Q.3 State the rule to find the direction of magnetic field produced around a current-carrying conductor.

Short Answer Type Questions (3 mark)

- Q.1 What is the role of fuse, used in series with any electrical appliance? Why should a fuse with defined rating not be replaced by one with a larger rating?
- Q.2 Why does a magnetic compass needle deflect when a bar magnet or a current-carrying loop is brought near it.

Value Based Question

The students of class 10th were excited as they were shown a documentary on “power consumption” during a Science Fair. The documentary explained that we use Alternating Current in our home and factory which is dangerous if not handled properly. Short circuiting and overloading are the two main causes for electrical hazards. Short circuiting occurs when the live wire and the neutral wire

come into direct contact. In this situation, the resistance of the circuit becomes very small and a very large current flows through the circuit which produces large amount of heat. This heat raises the temperature of the circuit and sparking at the point of short circuiting. Overloading means flow of current in the circuit beyond a specified limit. Overloading occurs due to an accidental rise in the supply voltage. Sometimes overloading is caused by connecting too many appliances of high power rating to a single socket. At the end students were happy as they got lot of information on power use.

- 1) What causes short circuit?
- 2) What do you mean by the term 'Overloading'?
- 3) What values do the students learn from the Documentary?

- A.1) Short circuiting occurs when the live wire and the neutral wire come into direct contact.
 2) Overloading means flow of current in the circuit beyond a specified limit.
 3) Concern for safety /Scientific temperament

CHAPTER 14- SOURCES OF ENERGY

1. Our energy requirements increase with our standard of living.
2. Characteristics of good source of energy.

High efficiency/easy to use/easy to store and transport/ economical/easily accessible.

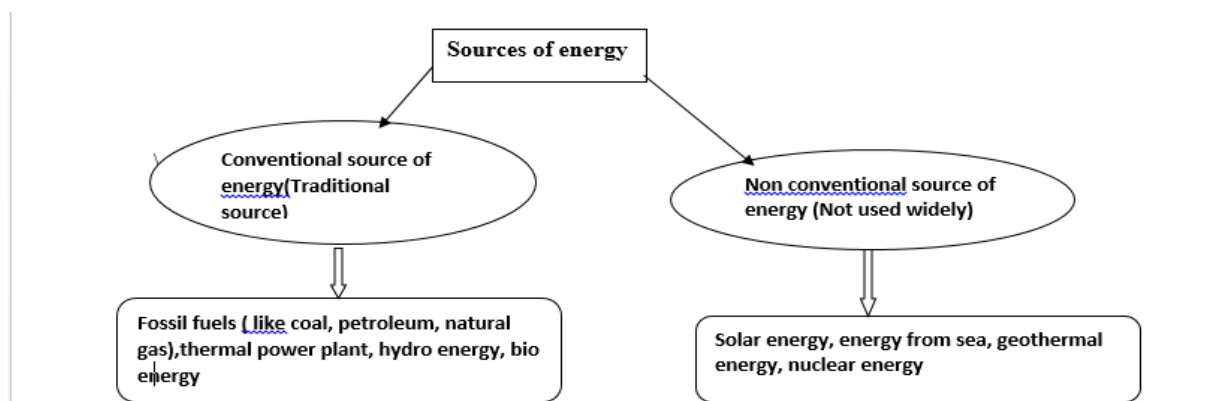

4. Fossil fuels are nonrenewable/exhaustible/causes air pollution, acid rain and global warming.
5. Biogas is formed by the decomposition of cow dung, agricultural and domestic wastes.

Composition of biogas

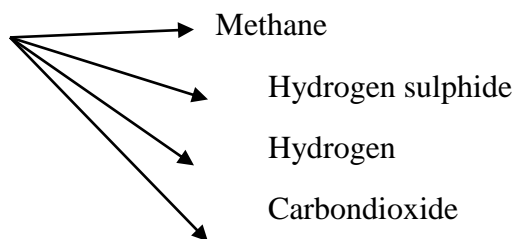

Advantages of bio gas : Pollution free/Wealth from wastes/No residue/high efficiency.

6. Wind energy : Kinetic energy of the wind is used to do the useful work .

Advantages: Renewable/inexhaustible/pollution free/no residue.

Disadvantages :-High cost of installation/minimum wind speed 15km/h/ maintenance cost high/requirement of large area of land.

7. Solar cells are devices which convert light energy into electric energy.

Advantages :-inexhaustible/pollution free/used in artificial satellites/can be used in remote areas/ low cost of maintenance.

Disadvantages:-Requirement of special grade of silicon/high cost of installation/moderate efficiency.

8. In nuclear power plants, nuclear energy is used for the production of electricity.

Advantage :-Very high efficiency

Disadvantage:-Radio active emissions/fear of nuclear power plant accidents/disposal of Radio active wastes.

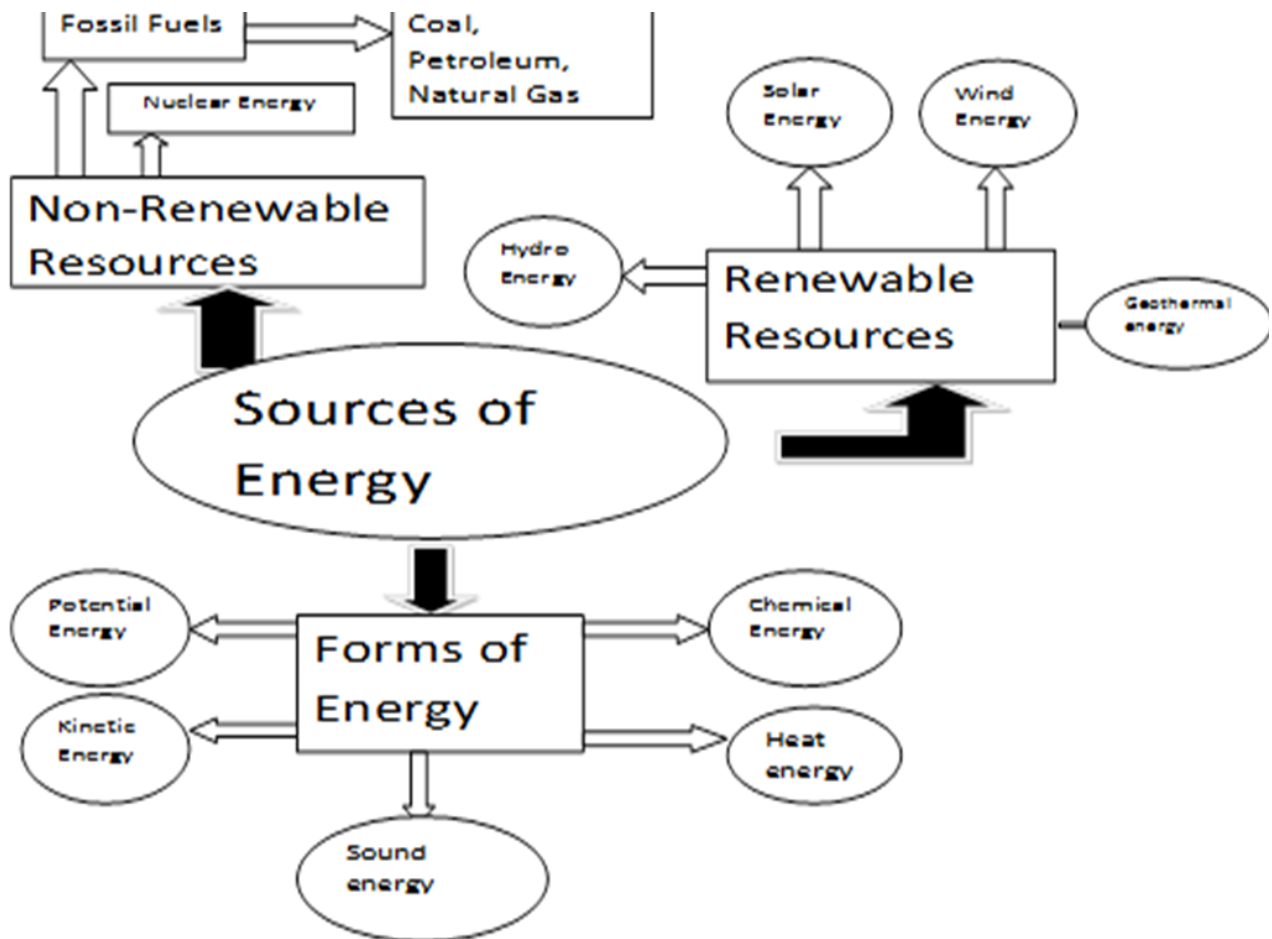

DIAGRAMS

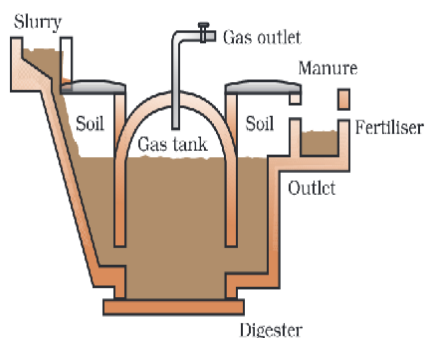

Figure 14.1
Schematic diagram of a bio-gas plant

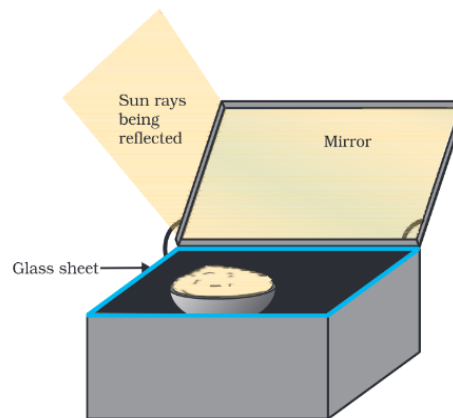

Figure 14.2 A solar cooker

CROSSWORD

Find the hidden words related with the chapter sources of energy.

(You can go across and down)

A	B	F	S	O	S	T	D	N	K	M	G
E	D	W	D	D	M	M	B	C	F	E	E
F	A	G	G	D	K	E	M	M	T	Y	O
Q	E	E	F	F	L	T	F	F	V	U	T
K	D	Q	A	R	I	H	Q	H	R	K	H
L	L	H	D	B	R	A	S	D	F	G	E
S	O	L	A	R	E	N	E	R	G	Y	R
O	Y	G	H	K	J	E	F	K	D	B	M
L	C	L	K	H	G	D	L	K	H	M	A
A	B	I	O	G	A	S	N	J	K	L	L
R	I	Y	T	G	K	H	M	J	K	L	E
C	O	T	E	F	I	S	S	I	O	N	N
E	M	V	C	V	B	M	T	B	V	K	E
L	A	R	T	I	U	K	Y	G	J	L	R
L	S	A	G	F	I	L	U	T	K	I	G
D	S	D	G	G	T	N	I	E	R	T	Y

QUESTION BANK

Very short answer type questions (1mark)

1. Expand OTEC.
- 2 Thermal power plants are set up near coal or oil fields. Give reason

Short answer type questions. (2 mark)

1. Hydrogen has been used as a rocket fuel. Would you consider it a cleaner fuel than CNG? Why or why not?
2. Fire wood is our conventional fuel. List any four reasons of replacing it with the alternate sources of energy.
3. List two advantages and disadvantages each for using wind as a source of energy.

Short answer type questions. (3mark)

1. What is solar cell panel? List two advantages and disadvantages each of using Solar cells for producing electricity.

VALUE BASED QUESTION

Rohan, a class 10 student was helping his mother in her cooking. His mother stressed the importance of using copper bottom vessels for cooking and switching off of gas cylinder regulator after the use.

- a) What value is shown by his mother?
- b) Why is Rohan's mother so particular of using copper bottom vessel for cooking?

Long answer type questions. (5 mark)

8 Describe the design and function of each part of a solar cooker with the help of a neat labelled diagram.

PRACTICAL BASED QUESTIONS

1. Four solutions of i, ii, iii, iv were given to test their acidic or basic nature by using paper. It was observed that the colour of pH paper turned to red, blue, green, and orange respectively when dipped in four solutions. The correct conclusion would be:-

- a) i, ii, and iii are acidic
- b) i, and iv are acidic
- c) ii, iii, and iv are acidic
- d) iii is acidic

2. When a student added zinc granules to dil.HCl, a colorless and odorless gas evolved. On testing with a burning matchstick it was observed that the matchstick:

- a) Continued to burn brilliantly
- b) Burnt slowly with a blue flame
- c) Extinguished
- d) Burnt with a pop sound

3. A small amount of quick lime is taken in a beaker. Water is added slowly to the beaker.

- a) Hissing sound and the solution becomes hot
- b) A hissing sound and the solution becomes cold
- c) Hissing sound and the solution becomes cold
- d) No sound and solution becomes hot

4). Reddish brown deposit observed on iron nails, when these are kept in aqueous solution of Copper sulphate is that of

- a) Copper oxide
- b) Copper
- c) Copper sulphide
- d) Iron sulphate

5. When a solution of barium chloride in water is added to an aqueous solution of sodium sulphate, the following happens:

- a) A white precipitate is formed.
- b) A red precipitate is formed
- c) The colour of the solution turns blue

d) A pungent smelling gas is evolved.

6. A strip of copper was placed in a beaker containing zinc sulphate solution. On observing the strip the next day, it was noticed that

- a) The copper strip remained as it was
- b) The copper strip became thinner
- c) The copper strip became thicker
- d) The colour of copper strip changed

7. A student puts one big iron nail in four test tubes containing solutions of zinc sulphate, aluminium sulphate, copper sulphate and iron sulphate. A reddish brown coating was observed only on the surface of iron nail which was put in the solution of

- a) Zinc sulphate
- b) Iron sulphate
- c) Copper sulphate
- d) Aluminum sulphate

8. The current flowing through a resistor connected in an electric circuit and the potential difference developed across its ends are shown in the given diagrams

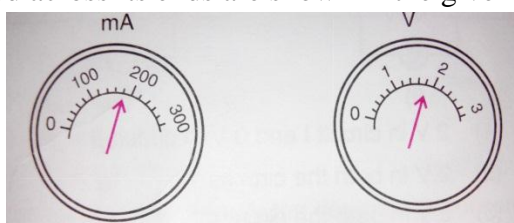

The value of resistance is

- a. 25
- b. 20
- c. 15
- d. 10

9. Function of the rheostat in the circuit arrangement to find V-I relationship for a conductor is

- a) To prevent the battery from short circuiting
- b) To adjust the value of the current passing in the circuit
- c) To adjust potential difference in the circuit
- d) To adjust the value of the resistance of the given conductor

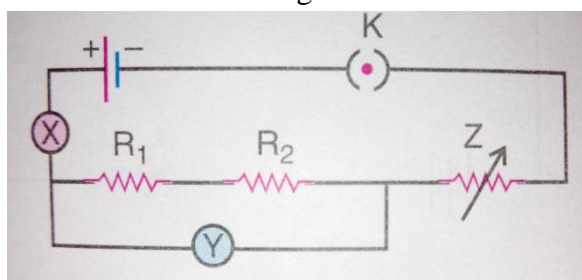

10. The component x, y, and z shown in the circuit respectively represents

- a) Rheostat, resistor, ammeter
- b) Ammeter, voltmeter, rheostat
- c) Voltmeter, ammeter, rheostat
- d) Rheostat, ammeter, voltmeter

10. To determine equivalent resistance of two resistors when connected in series, a student arranged the circuit as shown below.

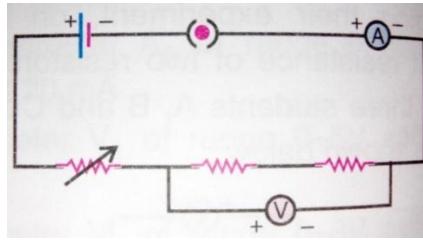

But he did not get the required result because

- a) Position of ammeter is not correct
- b) Position of voltmeter is not correct
- c) Terminals of voltmeter are wrongly connected
- d) Terminals of ammeter are wrongly connected

11. In the experiment for finding equivalent resistance of two resistors connected in parallel, three students connected the voltmeter in three ways X, Y, Z as shown below

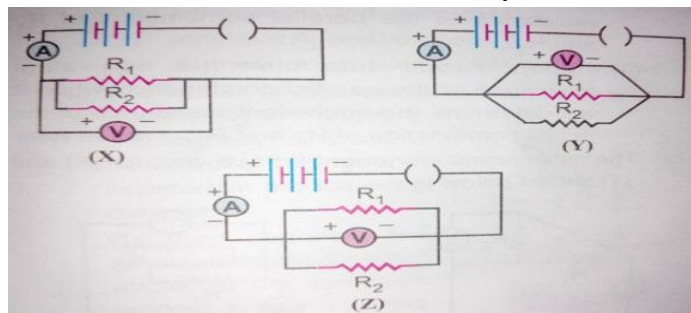

The voltmeter has been correctly connected in cases

- a) X and Y only
- b) Y and Z only
- c) X and Z only
- d) All the three

13. To determine the equivalent resistance of three resistors when connected in a parallel arrangement. Four students connected the resistors as follows

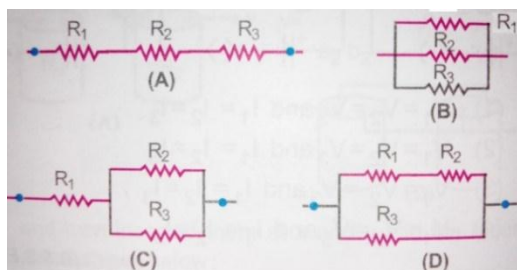

The correct setup is that of student

- a) A
- b) B
- b) C
- d) D

14. In the following diagram of the stomatal apparatus, which parts are incorrectly labelled?

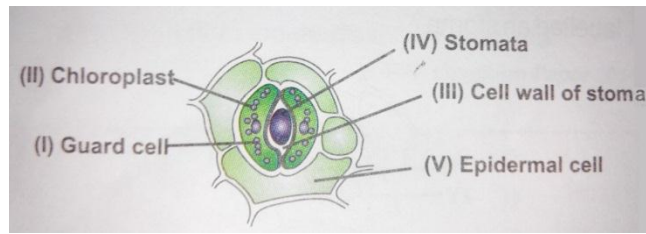

- a) I and IV
- b) II and III
- c) IV and V
- d) I and V

15. The steps involved in making a slide of epidermal peel of leaf are given as follows

- i. Pull out a thin peel from the lower surface of the leaf
- ii. Place a drop of glycerine on the slide
- iii. Place the peel in saffron
- iv. Place the stained peel on the glycerine
- v. Remove the extra stain by washing with water

vi. Place the cover slip over the peel

- a) i,ii,iii,iv,v,vi
- b) i,iii,v,ii,iv,vi
- c) i,iii,iv,ii,v,vi
- d) i,ii,iv,iii,v,vi

16. The teacher instructed a student to place a healthy potted plant in a dark room for 24 hours prior to an experiment on photosynthesis. The purpose of placing it in a dark room is

- a) To increase the intake of carbon dioxide
- b) To activate the chloroplast in the leaves
- c) To de-starch the leaves
- d) To denature the enzymes in the leaves

17. In an experiment to show that sunlight is necessary for photosynthesis, the leaf is boiled in alcohol for a few minutes using water bath. It is essential because

- a) Alcohol is highly volatile
- b) Steam from water bath heats the leaf
- c) Steam from water bath dissolves the chlorophyll
- d) Alcohol is inflammable

18. Potassium hydroxide is used during the respiration experiment because

- a) It releases oxygen
- b) It absorbs oxygen
- c) It absorbs carbon dioxide
- d) It releases carbon dioxide

20. A student sets up the apparatus for the experiment to show that carbon dioxide is released during respiration. After 2 hours, he observes that

- a) KOH turns milky
- b) Water level rises in the bent tube in the beaker
- c) Water level decreases in the bent tube in the beaker
- d) Water turns turbid in the beaker

6. Solution of CuSO_4 and FeSO_4 are placed in I and II test tubes respectively. Few pieces of Al are added to each solution. What will be the observations?

TERM 2

CHAPTER-4 CARBON AND ITS COMPOUNDS

IMPORTANT POINTS

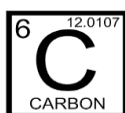

The chemical symbol of Carbon is C. Its atomic number is 6 and mass number is 12. It is a non-metallic element.

ALLOTROPES OF CARBON

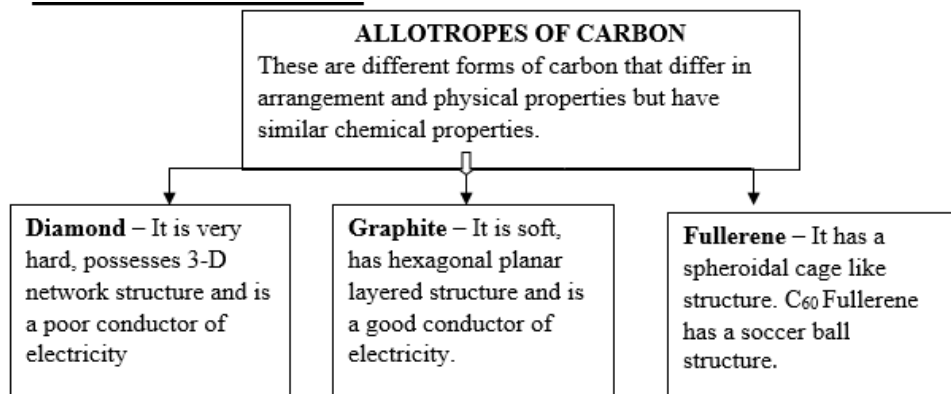

VERSATILE NATURE OF CARBON

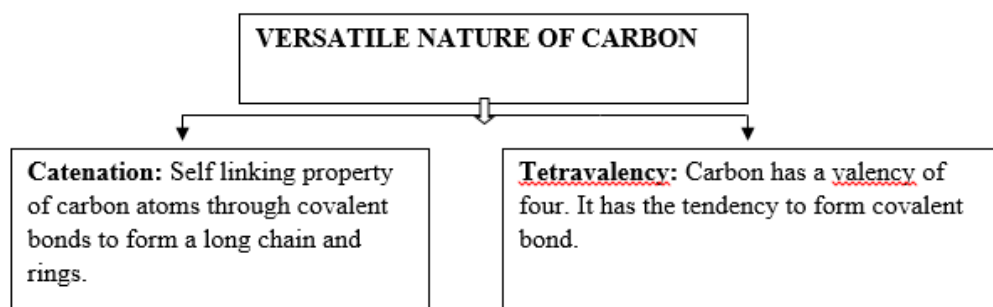

ISOMERISM - The phenomenon in which a compound has the same molecular formula but different structures is called isomerism.

ISOMERS -The compounds which have the same molecular formula but different structures and different properties are called isomers.

IUPAC – International Union of Pure and Applied Chemistry.

FUNCTIONAL GROUPS: Atoms or group of atoms responsible for the chemical properties of an organic compound.

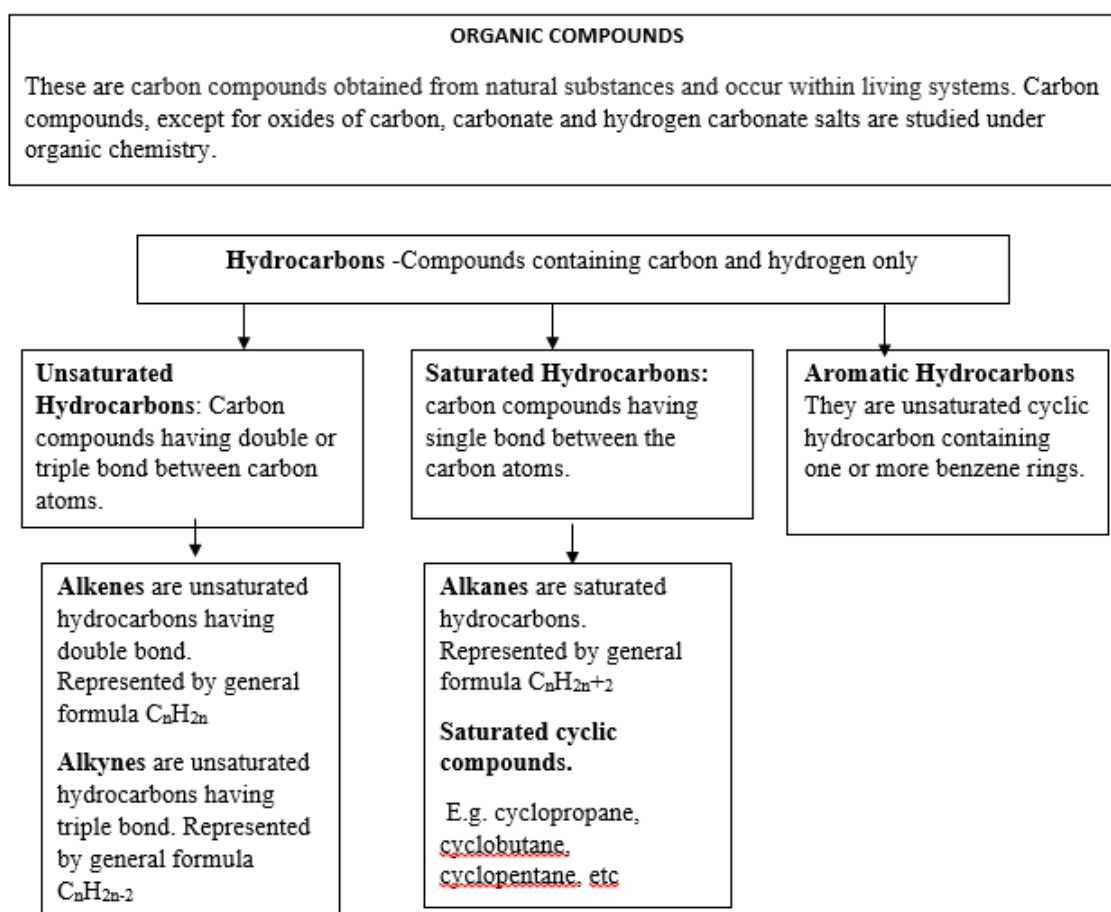

❖ In a hydrocarbon chain, one or more hydrogens can be replaced by some other element. In such compounds, the element replacing hydrogen is referred to as a **heteroatom**

Functional group	Symbol/formula	Prefix/suffix	Compound name
Halo	-Cl, -Br, -I	Halo (prefix)	<u>Haloalkane</u>
Alcohol	-OH	-ol	Alkanol
Aldehyde	-CHO	-al	<u>Alkanal</u>
Ketone	-CO-	-one	<u>Alkanone</u>
Carboxylic acid	-COOH	-oic acid	<u>Alkanoic acid</u>

HOMOLOGOUS SERIES –A series of compounds having same functional group and similar chemical properties but differ by--CH₂ unit between two successive members.

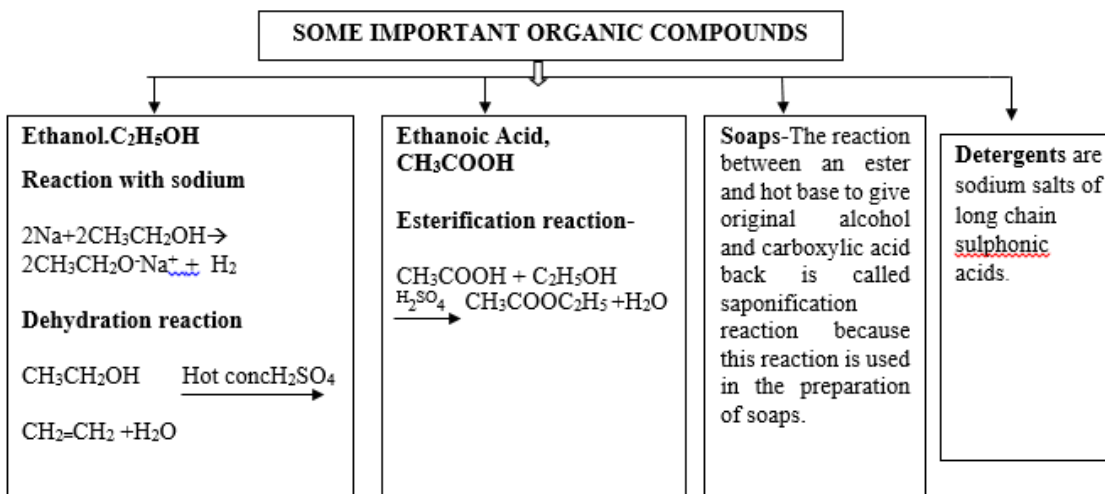

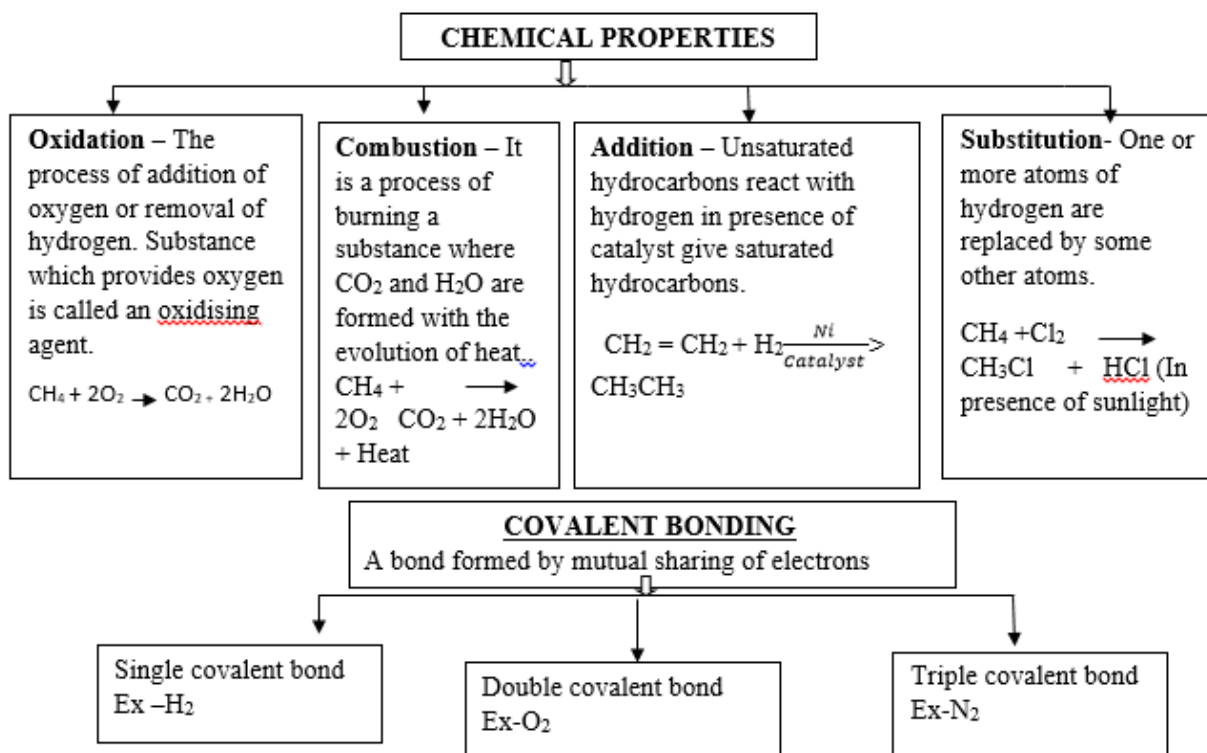

CROSSWORD

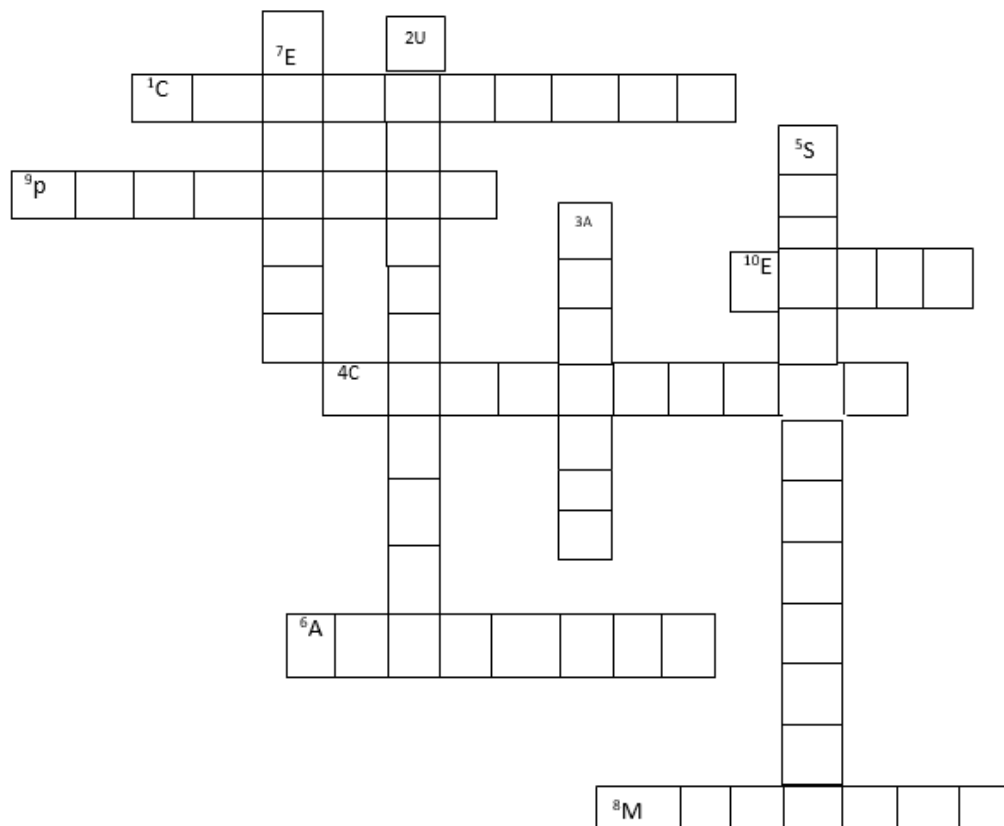

1. Self linking property of carbon
4. Acid having functional group -COOH
- 6 .Hydrogenation of vegetable oil is ---- reaction
8. Simplest hydrocarbon
- 9 IUPAC name of next higher homologous of ethanol
10. The substance used in making perfumes and flavoring agents

DOWN

2. Hydrocarbon burns in air with sooty flame.
3. The functional group present in methanol.
5. Chlorination of alkanes is ----- reaction
7. The active ingredient of all alcoholic drinks.

Question Bank

Answer the following questions.

Very short answer questions (1 mark)

1. Which of the following formulae represents a saturated hydrocarbon?
 C_nH_{2n} , $\text{C}_n\text{H}_{2n-2}$, $\text{C}_n\text{H}_{2n+2}$, $\text{C}_n\text{H}_{2n+1}$
2. Draw the electron dot structure of Ethene .

Short answer question (2mark)

1. Why is the conversion of ethanol to ethanoic acid an oxidation reaction?
2. What is meant by denatured alcohol? What is the need to denature alcohol?

Short answer question (3 mark)

1. An organic compound A of molecular formula C_2H_6O on heating with excess of conc. H_2SO_4 gives compound B of molecular formula C_2H_4 . Compound B on reduction gives compound C of molecular formula C_2H_6 .

- a) Name A, B and C.
- b) Write the chemical equation for the conversion of A to B
- c) What is the role of conc. H_2SO_4 in above equation? (HOTS)

VALUE BASED QUESTION

Meera and her mother were travelling in a CNG auto. The auto driver took the auto to the CNG filling station for filling the empty cylinder. Meera asked her mother about the gas used to fill the cylinder. Her mother replied that the gas used was CNG. CNG is used in place of petrol or diesel because it is cheaper, pollution free and eco-friendly.

Answer the following questions

- a) What is the long form of CNG?
- b) Name the main constituent of CNG.
- c) What value have you learnt after reading the text?

Long answer question (5 mark)

1. An organic compound with molecular formula $C_2H_4O_2$ produces brisk effervescence on addition of sodium carbonate /bicarbonate.

- a. Identify the organic compound.
 - b. Name the gas evolved.
 - c. How will you test the gas evolved ?
 - d. Write the chemical equation for the above reaction.
 - e. List two important uses of the above compound (HOTS)
- 2 .a. List two reasons for carbon forming a large number of compounds.

b. Name the type of bonding found in most of the carbon compounds. Why does carbon form compounds mainly by this kind of bonding?

c. Give reason.

- (i) Carbon compounds generally have low melting and boiling points.
- (ii) Carbon compounds do not conduct electricity .

Multiple choice questions

1. Vinegar is a solution of
- (a) 50% – 60% acetic acid in alcohol
 - (b) 5% – 8% acetic acid in alcohol

- (c) 5% – 8% acetic acid in water
 (d) 50% – 60% acetic acid in water
2. On adding NaHCO_3 to acetic acid, a gas is evolved which turns lime water milky due to formation of
- (a) Calcium bicarbonate
 (b) Calcium hydroxide
 (c) Calcium carbonate
 (d) Calcium acetate
3. Dilute acetic acid was added to the four test tubes containing the following chemical.
 i. KOH ii. NaHCO_3 iii. K_2CO_3 iv. NaCl
 Brisk effervescence was observed in test tubes
 a) i & ii b) ii & iii c) i & iv d) ii & iii
4. Few drops of ethanoic acid was added to solid sodium carbonate. The observation made was that
 a. A pungent smelling gas evolved. b. Brown fumes evolved. c. Brisk effervescence occurred. d. A hissing sound was evolved
5. 2 ml of acetic acid was added in drops to 5 ml of water it was noticed that:
 a. A pink and clear solution was formed.
 b. Water formed a separate layer on the top of the acid.
 c. A clear and homogeneous solution was formed.
 d. The acid formed a separate layer on the top of water

Practical based question (2 marks)

1. 1 ml of glacial acetic acid and 1 ml of ethanol are mixed together in a test tube. Few drops of concentrated sulphuric acid is added in the mixture and warmed in a water bath for 5 min.
- a. Name the resultant compound formed.
 b. Represent the above change by a chemical equation.
 c. What term is given to such a reaction?
 d. What are the special characteristics of the compound formed.
2. An organic compound with molecular formula $\text{C}_2\text{H}_4\text{O}_2$ produces brisk effervescence on addition of sodium carbonate / bicarbonate.
- a. Identify the organic compound.
 b. Name the gas evolved.

CHAPTER 5

PERIODIC CLASSIFICATION OF ELEMENTS

Dobereiner's Triads

Dobereiner observed that when elements were arranged into groups of three in the order of their increasing atomic masses, the atomic mass of the middle element was the arithmetic mean of rest of the two.

Limitation

Could be applied only to limited number of elements.

Newlands' Law of Octaves

Newlands found that every eighth element has chemical properties when they are arranged in increasing order of their atomic masses.

Limitations

- Could be valid up to calcium only
- Newlands assumed that only 56 elements existed in nature and no more elements would be discovered.

Mendeleev's Periodic Classification

Mendeleev's Periodic Law states that the properties of elements are the periodic function of their atomic masses.

Merits of Mendeleev's Periodic Table

- Mendeleev left some blank spaces for undiscovered elements.
- Mendeleev predicted the discovery of some elements and named them as eka-boron, eka-aluminium and eka-silicon.
- Noble gases discovered later could be placed without disturbing the existing order.

Limitations of Mendeleev's Periodic Table

- **Position of Hydrogen-** Could not assign a correct position to hydrogen as hydrogen resembles alkali metals as well as halogens
- **Position of Isotopes-** Isotopes are placed in same position though they have different atomic masses
- **Separation of chemically similar elements while dissimilar elements are placed in the same group.**

Modern Periodic Classification

Modern Periodic Law states that properties of elements are the periodic function of their atomic numbers.

Groups in Modern Periodic Table:

Group 1	Alkali metals
Group 2	Alkaline earth metals

Groups 3 to 12	Transition elements
Group 13	Boron family
Group 14	Carbon family
Group 15	Nitrogen family
Group 16	Oxygen family
Group 17	Halogens
Group 18	Noble gases

Periods in Modern Periodic Table

Period	No of elements
1 st period	2 (H,He)
2 nd and 3 rd period	8 (Li,Be,B ,C,N,O,F,Ne)
4 th and 5 th period	18
6 th period	32
7 th period	Incomplete period

Trends in Modern Periodic Table:

Property	Variation along the group	Variation along the period
Valency	Remains the same	Increases up to group 14 then decreases
Atomic radii	Increases	Decreases
Metallic character	Increases	Decreases
Electropositive character	Increases	Decreases
Electronegativity	Decreases	Increases

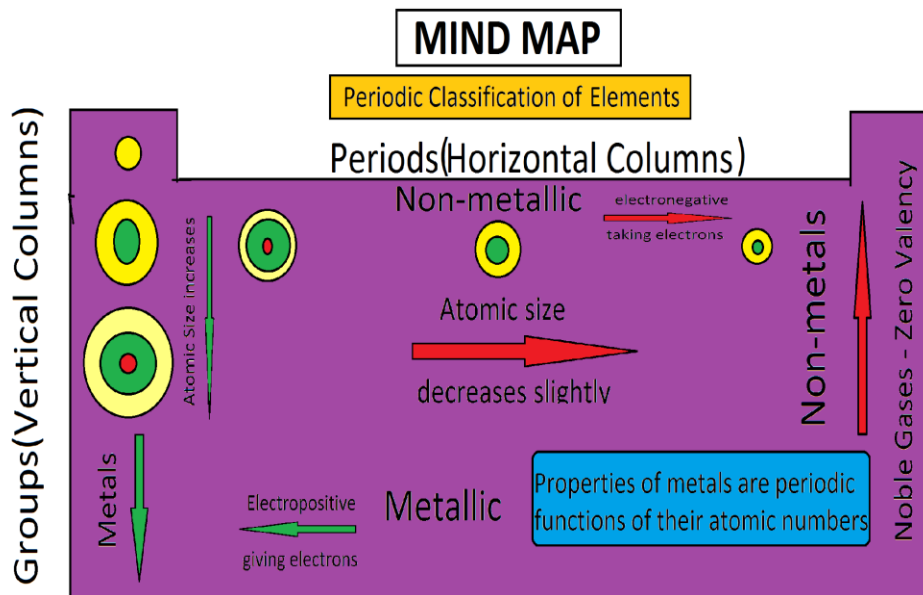

DIAGRAMS

Döbereiner's triads

Li	Ca	Cl
Na	Sr	Br
K	Ba	I

Notes of music:

sa (do)	re (re)	ga (mi)	ma (fa)	pa (so)	da (la)	ni (ti)
H	Li	Be	B	C	N	O
F	Na	Mg	Al	Si	P	S
Cl	K	Ca	Cr	Ti	Mn	Fe
Co and Ni	Cu	Zn	Y	In	As	Se
Br	Rb	Sr	Ce and La	Zr	—	—

NEWLAND'S OCTAVES

Table 5.6 Modern Periodic Table

The zigzag line separates the metals from the non-metals.



GROUP NUMBER	1	2	GROUP NUMBER										13	14	15	16	17	18			
P	1	2	3	4	5	6	7	8	9	10	11	12	13	14	15	16	17	18			
E	H Hydrogen 1.0	He Helium 4.0	Li Lithium 6.9	Be Beryllium 9.0	B Boron 10.8	C Carbon 12.0	N Nitrogen 14.0	O Oxygen 16.0	F Fluorine 19.0	Ne Neon 20.2	Na Sodium 22.9	Mg Magnesium 24.3	Al Aluminium 27.0	Si Silicon 28.1	P Phosphorus 31.0	S Sulphur 32.1	Cl Chlorine 35.5	Ar Argon 39.9			
R			19	20	21	22	23	24	25	26	27	28	29	30	31	32	33	34	35	36	
I			K Potassium 39.1	Ca Calcium 40.1	Sc Scandium 44.9	Ti Titanium 47.9	V Vanadium 50.9	Cr Chromium 52.0	Mn Manganese 54.9	Fe Iron 55.8	Co Cobalt 58.9	Ni Nickel 58.7	Cu Copper 63.5	Zn Zinc 65.4	Ga Gallium 69.7	Ge Germanium 72.6	As Arsenic 74.9	Se Selenium 78.9	Br Bromine 79.9	Kr Krypton 83.8	
O			37	38	39	40	41	42	43	44	45	46	47	48	49	50	51	52	53	54	
D			Rb Rubidium 85.5	Sr Strontium 87.6	Y Yttrium 88.9	Zr Zirconium 91.2	Nb Niobium 92.9	Mo Molybdenum 95.9	Tc Technetium 98.9	Ru Ruthenium 101.1	Rh Rhodium 102.9	Pd Palladium 106.4	Ag Silver 107.9	Cd Cadmium 112.4	In Indium 114.8	Sn Tin 118.7	Sb Antimony 121.8	Te Tellurium 127.6	I Iodine 126.9	Xe Xenon 131.3	
S			55	56	57	72	73	74	75	76	77	78	79	80	81	82	83	84	85	86	
			Cs Caesium 132.9	Ba Barium 137.3	La* Lanthanum 138.9	Hf Hafnium 178.5	Ta Tantalum 180.9	W Tungsten 183.8	Re Rhenium 186.2	Os Osmium 190.2	Ir Iridium 192.2	Pt Platinum 195.1	Au Gold 197.0	Hg Mercury 200.6	Tl Thallium 204.4	Pb Lead 207.2	Bi Bismuth 208.9	Po Polonium 209	At Astatine 210	Rn Radon 222	
			87	88	89	104	105	106	107	108	109	110	111	112	113	114	115	116	117	118	
			Fr Francium 223	Ra Radium 226	Ac** Actinium 227	Rf Rutherfordium 261	Db Dubnium 262	Sg Seaborgium 266	Bh Bohrium 264	Hs Hassium 277	Mt Meitnerium 268	Ds Darmstadtium 285	Rg Roentgenium 288	Uub Ununbium 289	Uuq Ununquadium 289	Uuh Ununhexium 289	Uuq Ununquadium 289	Uuh Ununhexium 289	Uuo Ununoctium 289	Uuq Ununquadium 289	Uuh Ununhexium 289

58	59	60	61	62	63	64	65	66	67	68	69	70	71
Ce Cerium 140.1	Pr Praseodymium 140.9	Nd Neodymium 144.2	Pm Promethium 145	Sm Samarium 150.4	Eu Europium 151.9	Gd Gadolinium 157.3	Tb Terbium 158.9	Dy Dysprosium 162.5	Ho Holmium 164.9	Er Erbium 167.3	Tm Thulium 168.9	Yb Ytterbium 173.0	Lu Lutetium 175.0
90	91	92	93	94	95	96	97	98	99	100	101	102	103
Th Thorium 232	Pa Protactinium 231	U Uranium 238.1	Np Neptunium 237	Pu Plutonium 244	Am Americium 243	Cm Curium 247	Bk Berkelium 247	Cf Californium 251	Es Einsteinium 252	Fm Fermium 253	Md Mendelevium 258	No Nobelium 259	Lr Lawrencium 260

* Lanthanoides

** Actinoides

CROSSWORD

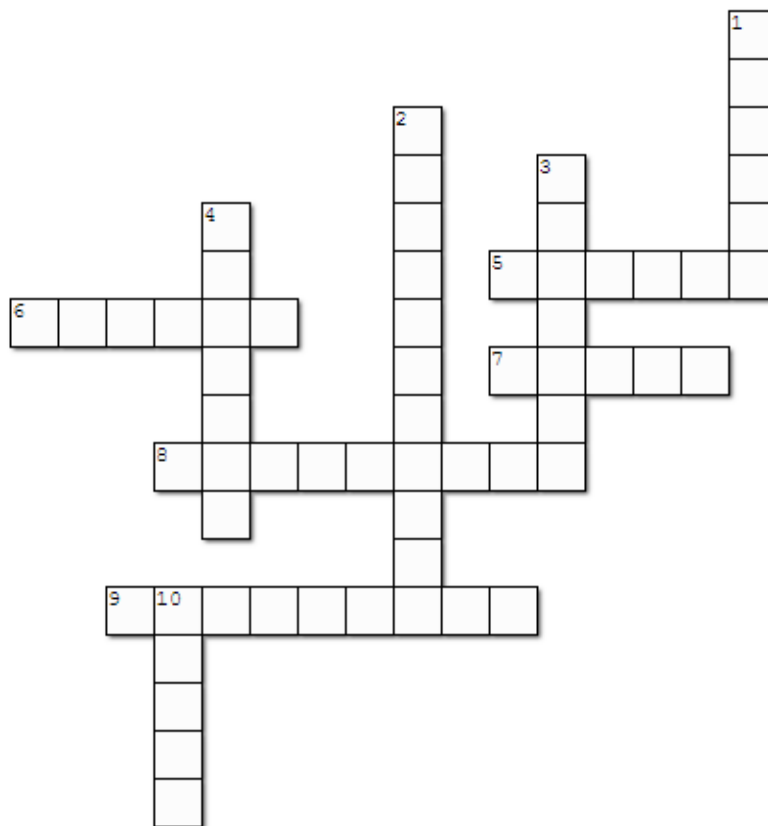

Created with TheTeachersCorner.net [Crossword Puzzle Generator](#)

Across

5. Vertical columns in the periodic table
6. Element with atomic number 6
7. Metalloid in Group 13
8. Variation of atomic size along the group
9. Variation of electronegativity along the group

Down

1. Elements that are electropositive in nature
2. Other name for inert gases
3. Horizontal rows in the periodic table
4. Non-metal that exists in liquid state at room temperature
10. Number of electrons in L shell

Question Bank: - Periodic Classification of Elements

Very Short Answer Type Questions(1 mark)

- Q1. Give an example of Dobereiner's triad.
- Q2. What is the basis of Mendeleev's periodic table?

Short Answer Type Questions(2 marks)

- Q1. State the modern periodic law for classification of elements. How many groups and periods are there in the modern periodic table?
- Q2. An element 'M' has atomic number 11.
 - (i) Write its electronic configuration.
 - (ii) State the group to which 'M' belongs.
 - (iii) Is 'M' a metal or a non-metal?
 - (iv) Write the formula of its chloride.
- Q3. Name two elements that show chemical properties similar to bromine. Give reason.
- Q4. An atom has electronic configuration 2, 8, 2.
 - (i) What is the atomic no. of this element?
 - (ii) Is it a metal or non-metal?

Short Answer Type Questions(3 marks)

Q1. The elements Li($Z = 3$), Na ($Z = 11$) and K ($Z = 19$) belong to group 1

- (i) Predict the periods they belong.
- (ii) Which one of them is least reactive?
- (iii) Which one of them has the largest atomic radius? Give reason to justify.

Q2. F, Cl and Br are the elements each having seven valence electrons.

Pick the element (i) with the largest atomic radius (ii) which is most reactive. Justify your answer.

Q3. Nitrogen($Z = 7$) and Phosphorus($Z = 15$) belong to same group-15 of the periodic table.

Write the electronic configuration of these two elements. Which of these two is more electronegative? Why?

Long Answer Type Questions (5marks)

Q1.(i) How does atomic size vary along the group? Give reason.

(ii) Why are metals electropositive in nature?

(iii) What are metalloids? Give an example.

Q2. Name-

- (i) Two elements that have a single electron in their outermost shells.
- (ii) Two elements that have two electrons in their outermost shells.
- (iii) Two elements with filled outermost shell.
- (iv) Two elements that belong to halogen family.
- (v) An element which is tetravalent and forms the basis of organic chemistry.

CHAPTER:8 HOW DO ORGANISMS REPRODUCE

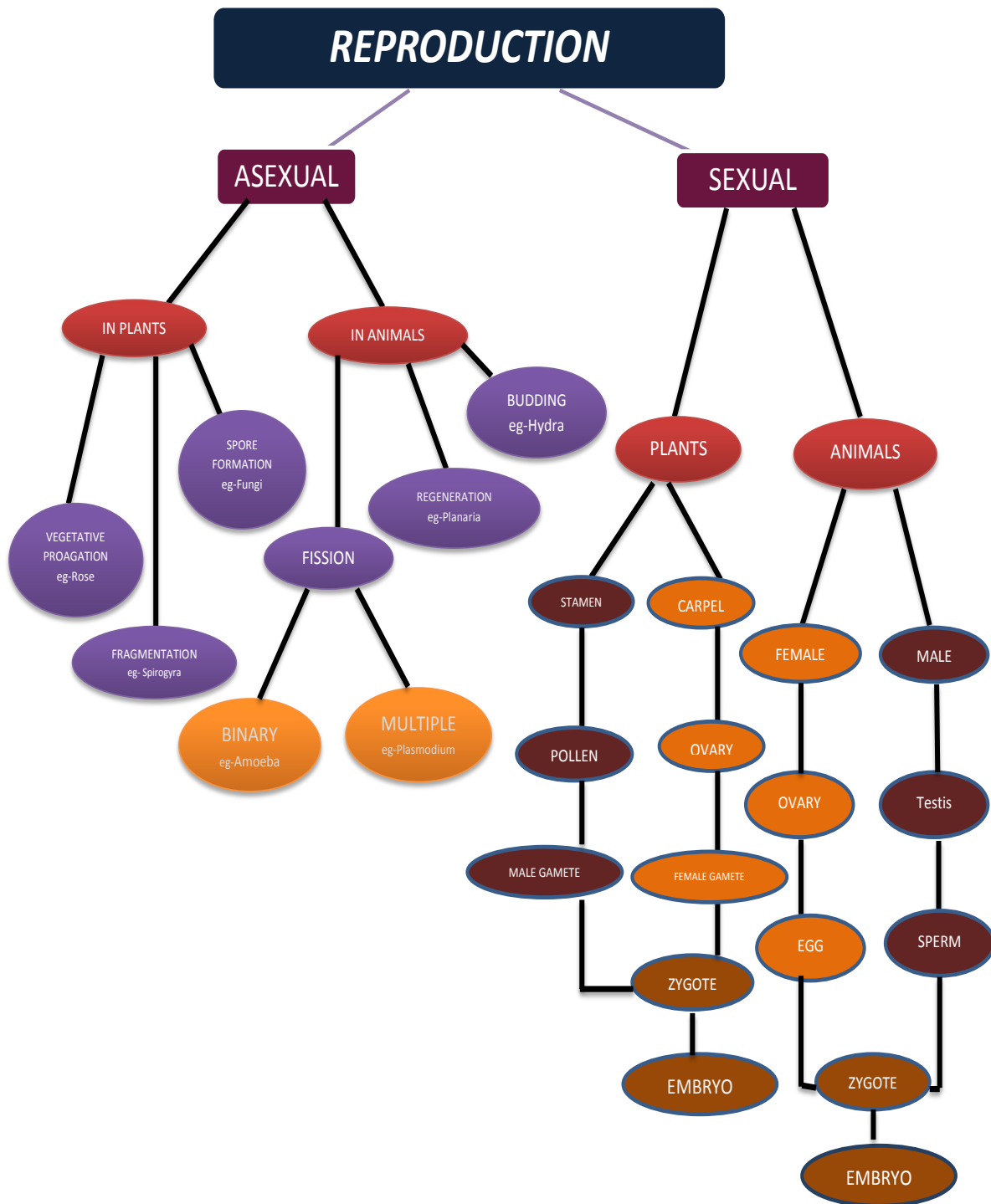

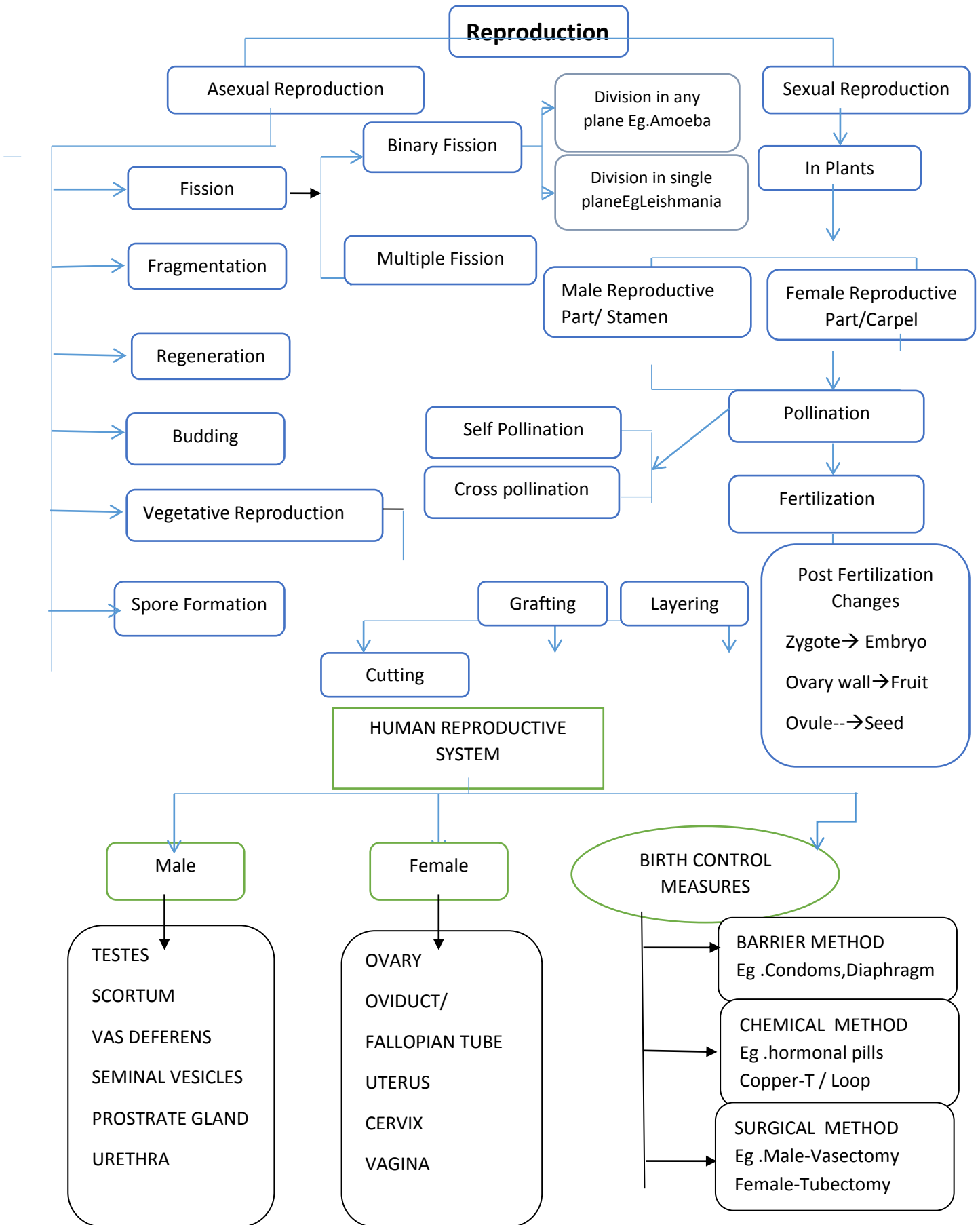

1. Advantages of Vegetative Propagation

It allows quicker and easy propagation/exact copy of the parent/ seedless plant propagation.

2 Disadvantages of Vegetative Propagation

Vegetative propagation doesn't favour much variation and evolution of new species.

3. Regeneration is the ability of an organism to regenerate the lost part. (eg: arm regeneration in star fishes). Sometimes, an organism can be made from its fragmented body parts. e.g. *Planaria*.

4 Flower is the reproductive part of the plant. A complete flower has four whorls- sepals, petals, stamens and carpels.

5 Unisexual flowers and bisexual flowers

Unisexual flowers	Bisexual flowers
Have either stamen or carpel e.g. Water melon, papaya	Have both stamen and carpel e.g. hibiscus, rose

6 Pollination: Transfer of pollen grains from anther lobe to the stigma of the flower.

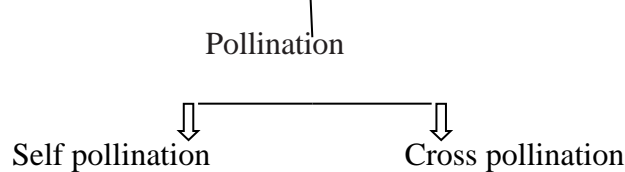

7 Post pollination changes in plants

Growth of pollen tube/motion of male gametes towards the ovule/ fertilisation

8. Fertilised ovule develops in to seed and ovary develops into fruit

9. Unisexual and bisexual organisms

Unisexual organisms	Bisexual organisms (Hermaphrodites)
Have only male or female reproductive organs e.g Human beings, cats, dogs	Have both male and female reproductive organs. e.g. Flatworms, earthworms, leeches.

10. The fusion of male and female gamete is called fertilisation.

11. Parts and functions

Male	Female
<u>Testis</u> :sperm production	<u>Ovary</u> : Egg production
<u>Vas deferens</u> :Sperm conducting path	<u>Fallopian tube</u> :Site of fertilisation
<u>Urethra</u> :Common passage for urine and sperms	<u>Uterus</u> :Site of implantation
<u>Seminal vesicle and prostate gland</u> : Nutrition and mobility	<u>Vagina</u> : Opening of birth canal

12. On reaching puberty, one egg is produced every month by one of the ovaries. The release of egg by the ovary is called ovulation, which takes place at 12-16th day of menstrual cycle. During that time, if sexual contact takes place, sperm fuses with the egg producing zygote which get implanted in the uterus at 32 cell stage.

13. It is through placenta glucose and oxygen are given to the developing embryo and waste materials are removed from embryo and given to the mother's blood.

14 Common birth control measures

- (a) Physical barrier methods like condoms and vaginal diaphragm/chemical methods like oral or vaginal pills/ surgical methods like tubectomy in females and vasectomy in males/IUCD e.g. Copper T

15 .STD are sexually transmitted diseases spread through sexual contact with the infected Person. Common bacterial STDs are syphilis and gonorrhoea. AIDS (Acquired ImmunoDeficiency Syndrome) and warts are examples of viral STDs.

IMPORTANT DIAGRAMS

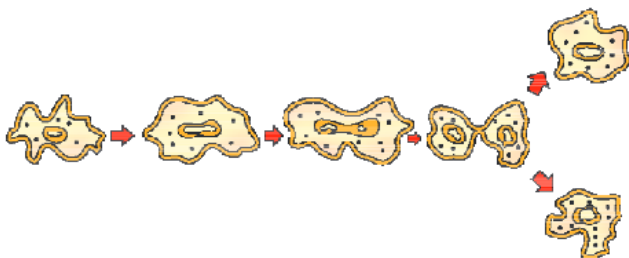

Figure 8.1 Binary fission in Amoeba

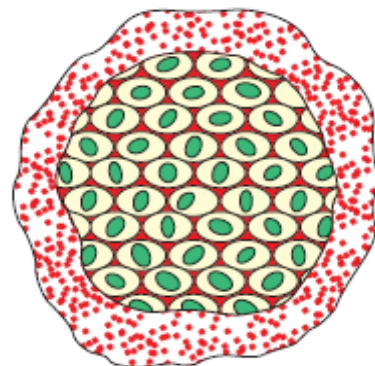

Figure 8.2
Multiple fission in Plasmodium

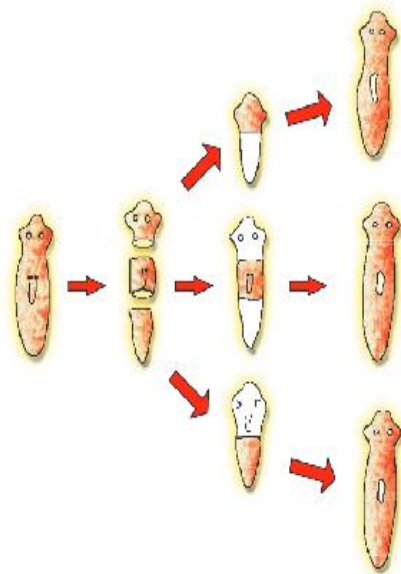

Figure 8.3 Regeneration in Planaria

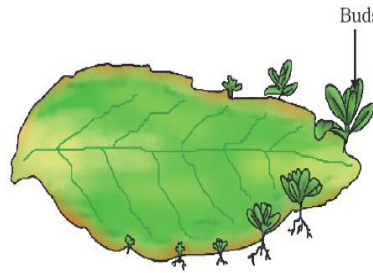

Figure 8.5
Leaf of Bryophyllum
with buds

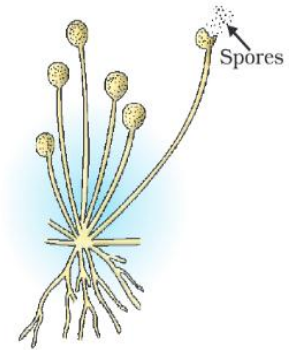

Figure 8.6
Spore formation in Rhizopus

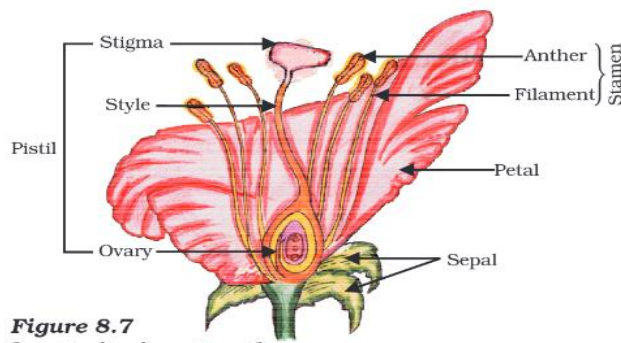

Figure 8.7
Longitudinal section of
flower

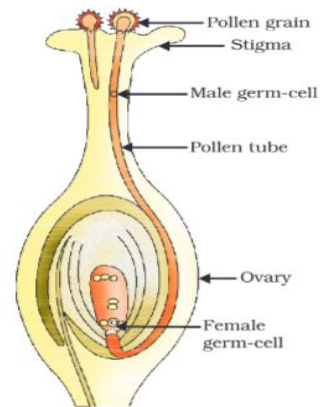

Figure 8.8
Germination of pollen on
stigma

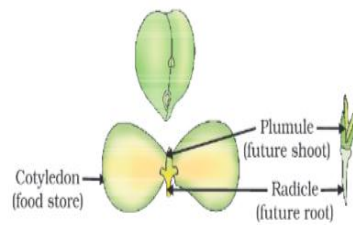

Figure 8.9
Germination

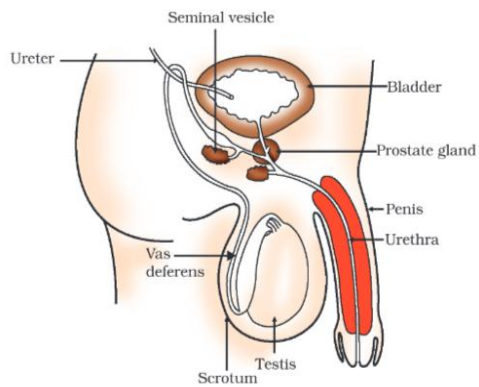

Figure 8.10 Human-male reproductive system

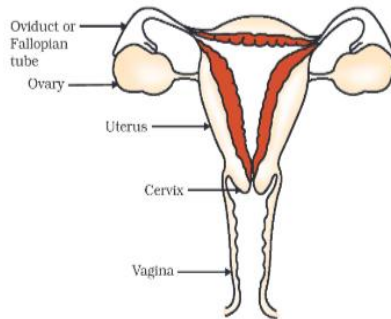

Figure 8.11 Human-female reproductive system

CROSSWORD



Across

1. Plasmodium reproduces by this method
4. Male reproductive part of a flower
5. Also called 'future shoot'
6. Female reproductive part of a flower
7. A contraceptive that creates a mechanical barrier
9. An organism that reproduces by budding and regeneration
11. The leaves of this plant produce buds for reproduction

Down

2. Embryo gets rid of waste through
3. A STD
8. The lower flask shaped part of the carpel.
10. I am the blue print of life.

QUESTION BANK

Very short answer questions(1 mark)

1. Name the plant in which vegetative propagation takes place by leaves.

Ans) Bryophyllum.

2. Write scientific term for the following:

a) Release of ovum from ovary.

Ans) Ovulation

b) Onset of menstrual cycle in a female.

Ans) Menarche.

3. Where does fertilization take place in human female?

Ans.) Oviduct (fallopian tube)

Short answer questions (2 mark)

1. What is the importance of DNA copying in reproduction?

Ans. DNA copying is essential for transferring genetic material from one generation to another.

2. How is pollination different from fertilization?

Ans. Pollination is the process of transfer of pollen grains from the anther lobe to the stigma of the flower, while fertilization is the process of fusion of male gamete and female gamete to form the zygote.

3. What is the role of seminal vesicles and the prostate gland?

Ans: Seminal vesicle and prostate gland help in nutrition and mobility of sperms.

Short answer questions(3 mark)

1. What are the advantages of vegetative propagation?

Ans: Quick/easy/economical method/can create exact copies of the parent/only method for the propagation of seedless plants.

2. How does the embryo get nourishment inside the mother's body?

Ans: the embryo gets nutrition, oxygen and gets rid of waste materials through Placenta.

3a) What is AIDS?

b) Name the causative organism?

c) List the important modes of transmission of the disease.

Ans. a) Acquired immunodeficiency syndrome.

b) HIV (human immunodeficiency virus)

- c)i) Sexual contact
- ii) Through infected blood transfusion
- iii) Contaminated syringes.
- iv) Infected mother to child.

4. What are the different methods of contraception?

Ans.a)Barrier method: condoms used by males /vaginal diaphragm used by females.

b)Chemical method: e.g oral pills /vaginal pills used by females

c)Surgical method: vasectomy in males /tubectomy in females

5.Sankalp is a student of class 10, who is very much neglected by his relatives. The reason for their behavior was death of his parents after suffering from a disease called AIDS. He is

Well taken care by his teachers and class mates.

(VBQ)

a) What values were shown by his teachers and classmates?

Ans. Caring/ knowledge of biology.

b) Will the disease called AIDS spread by sitting close to each other or by hand shaking with each other?

Ans) No, the disease wont spread by hand shake.

c) List two ways of transmission of the disease.

Ans))i) Sexual contact

ii) Infected blood

Long answer questions (5 mark)

1 . Explain the process of fertilization in plants with the help of neat labeled diagram

Ans. Hints : Formation of pollen tube ,movement of male gametes towards the ovule.

Fertilisation: Fusion of male and female gamete.

Neat labelled diagram : fig 8.8

10. Describe the different methods of asexual reproduction seen in animals with the help of neat labelled diagrams.

Ans.Description for the following:

1. Fission : binary and multiple fission
2. Regeneration
3. Bud formation

Fig :8.1,8.2,8.3,8.4

CHAPTER-9

HEREDITY AND EVOLUTION

FLOW CHART

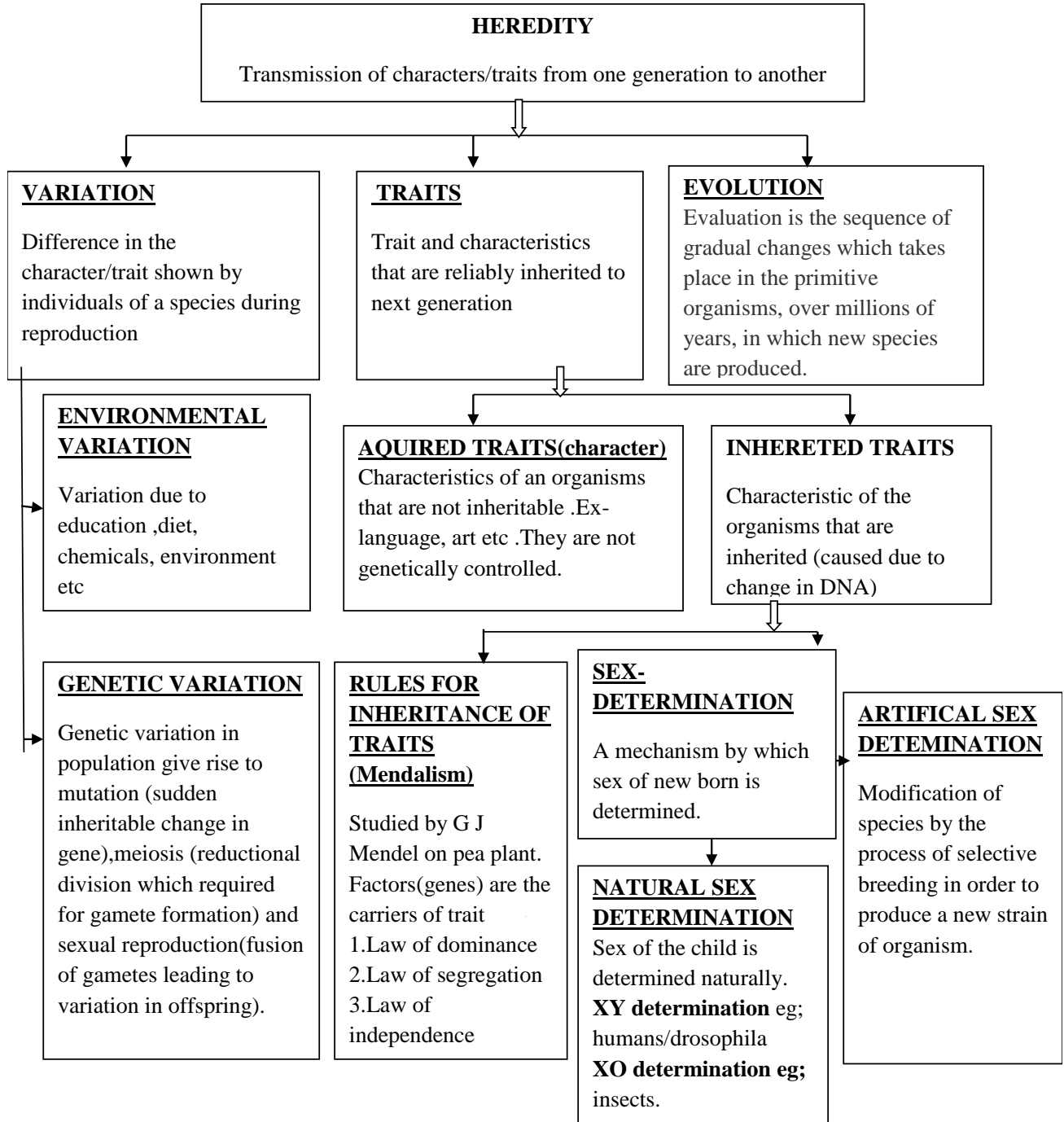

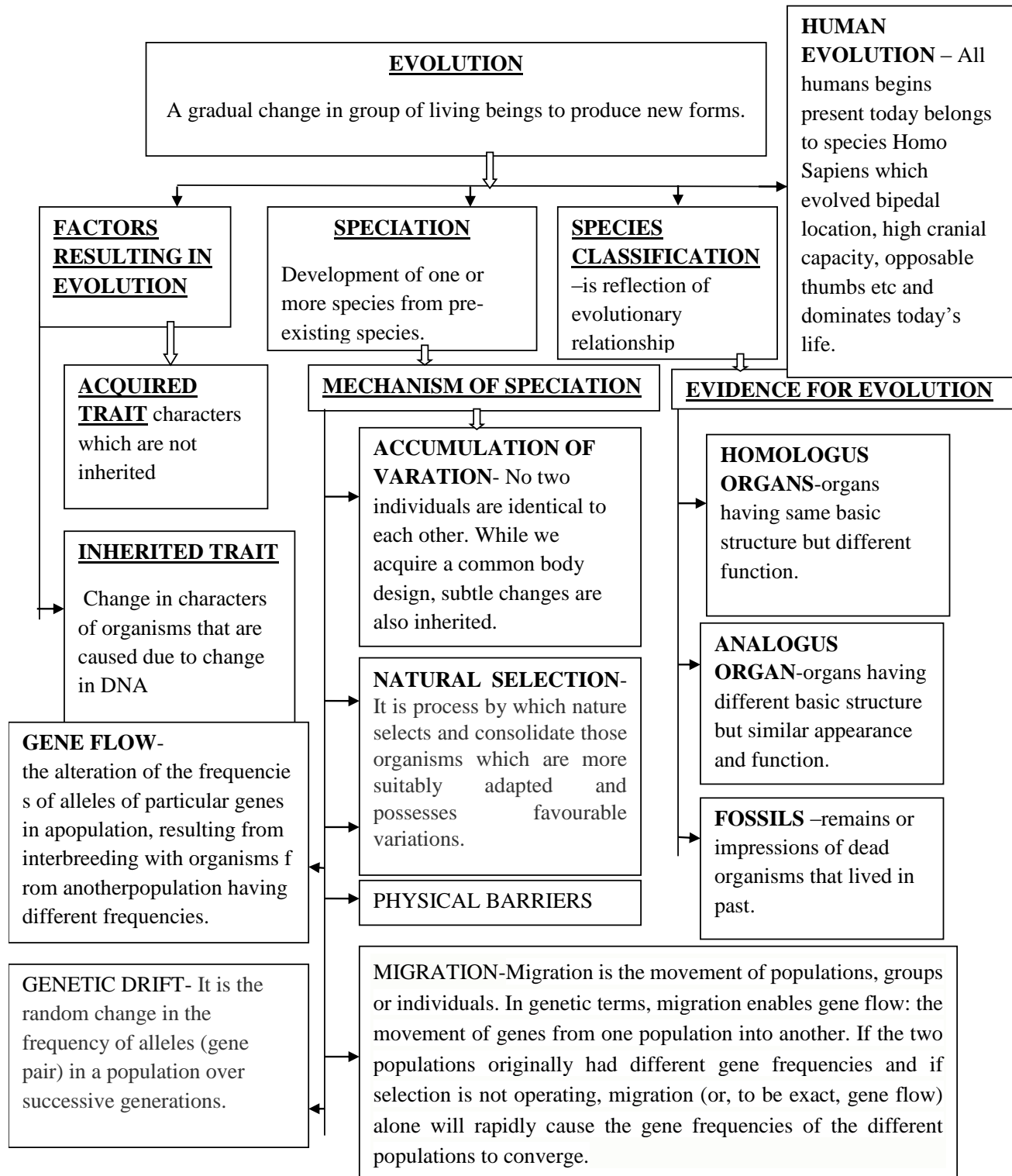

DEFINITIONS:- 1) GENE- Each character of an individual is determined by two factors.

2) GENOTYPE- Genes inherited from both the parents, may or may not be expressed are called genotype.

3)PHENOTYPE-Expressed structural and functional traits as a result of genes as well as environment

4)FOSSIL- Dead remain of plant and animal.

CROSSWORD

						1				
										4
5										
		3								
						2				
6										
				7						

DOWN

- 1. An individual having two different alleles for the same trait.
- 4. Reductional division which required for gamete formation.

ACROSS

- 2. A functional unit of trait.
- 5. Organs having different basic structure but similar appearance and function.
- 6. Sudden changes in the genetic form of organisms which are passed on to the next generation.
- 7. Remains or impressions of dead organisms that lived in past

UP

- 3. Theory of inheritance of acquired character is given by

Answer the following questions (1 mark)

1. Mention the ways by which variant genotypes are produced in an organism?
2. How are fossils helpful in developing evolutionary relationships?

Answer the following questions (2 mark)

1. How do Mendel's experiments show that traits may be dominant or recessive?
2. Does genetic combination of father play a significant role in determining the sex of the child?
Show with the help of a flow chart.

Answer the following questions (3 mark)

1) Sameer's father is a wrestler and has a well-built body. He was awarded as Mr. India when he was young. Sameer is his only son. As Sameer grew older, everyone expected him to have the same body built up as his father. But he is thin. His friends tease him and he feels depressed by it.

- a) Is it true that a wrestler's son should also have heavy muscles?
 - b) What type of character is it ; acquired or inherited?
 - c) What are the values shown by Sameer's friends? (VBQ)
- 3) When a tall plant is crossed with a dwarf plant .What will be the ratio of tall to dwarf plants in F1 generation? Show with a help of Mendal's cross.[HOTS]

Answer the following questions (5 marks)

1. How has the method of 'artificial selection' by humans helped in the evolution of different vegetables?
2. How do Mendel's experiments show that traits are inherited independently?

LIGHT - REFLECTION AND REFRACTION

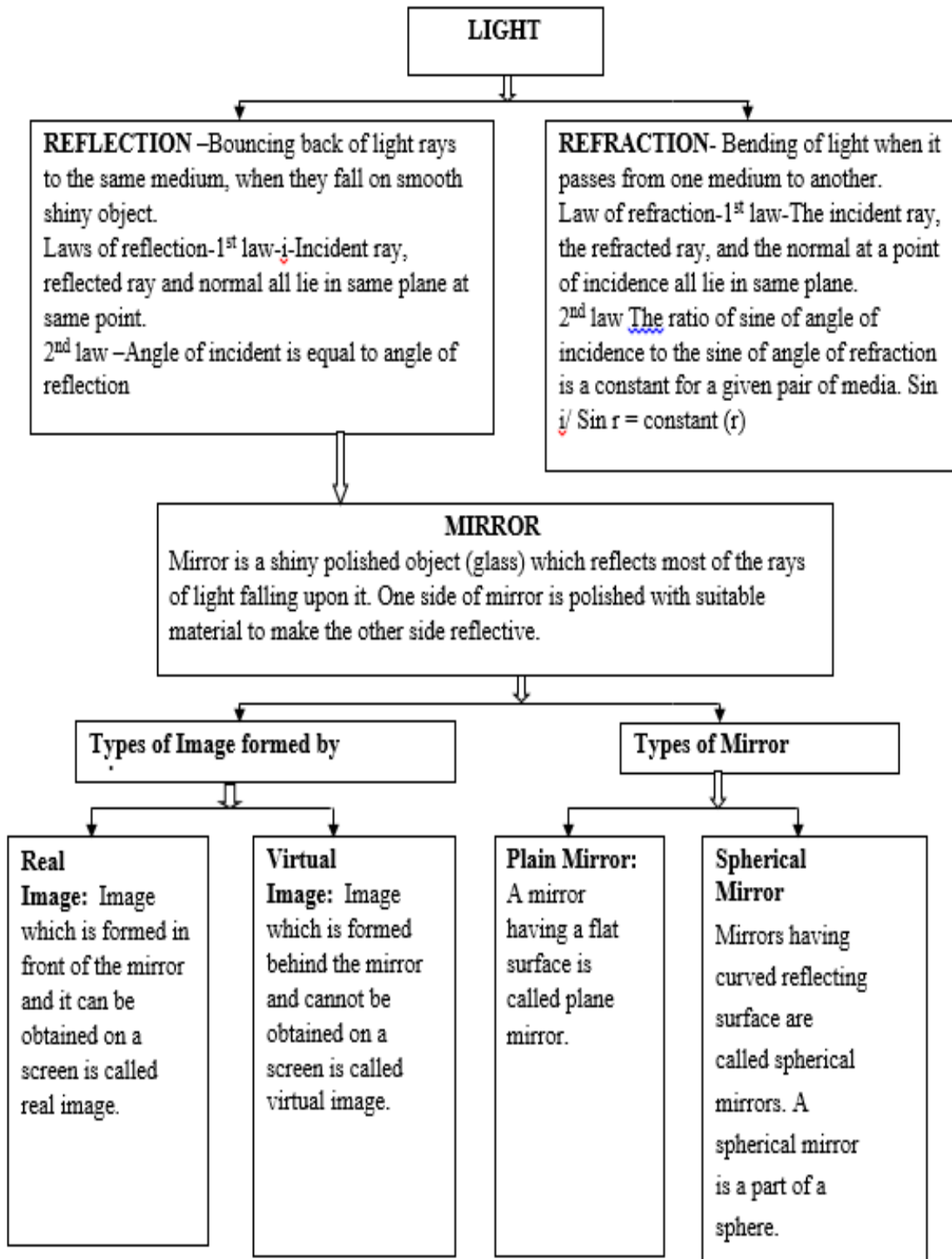

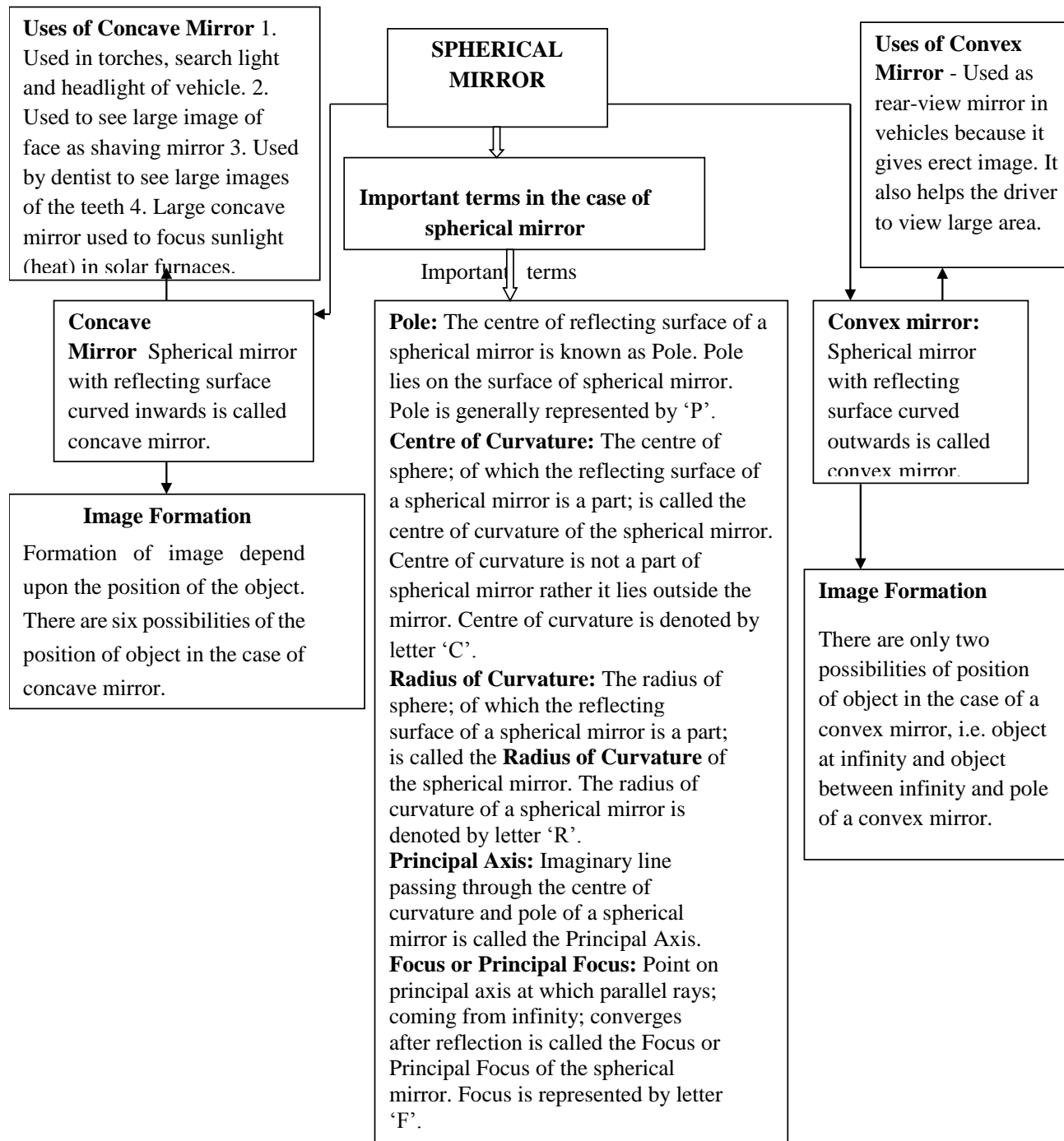

Sign Convention for Reflection by Spherical Mirror

1. The object is always placed to the left side of mirror.
2. All distance should be measured from pole (P); parallel to principal axis.
3. Take 'P' as origin. Distances measured Right of the origin (+ x - Axis) are taken positive and Left of the origin (- x-Axis) are taken negative
4. Perpendicular to and above principal axis (+y-Axis) are taken positive Perpendicular to and below principal axis (-y-Axis) are taken negative.

IMAGE FORMATION BY CONCAVE MIRROR FOR DIFFERENT POSITION

IMAGE FORMATION BY CONVEX MIRROR FOR DIFFERENT POSITION

SPHERICAL MIRROR

POSITION OF THE OBJECT	POSITION OF THE IMAGE	SIZE OF THE IMAGE	NATURE OF THE IMAGE
At infinity	At the focus F	Highly diminished, point-size	Real and inverted
Beyond C	Between F and C	Diminished	Real and inverted
At C	At C	Same size	Real and inverted
Between C and F	Beyond C	Enlarged	Real and inverted
At F	At infinity	Highly Enlarged	Real and inverted
Between P and F	Behind the mirror	Enlarged	Virtual and erect

See figure - 10.1

POSITION OF THE OBJECT	POSITION OF THE IMAGE	SIZE OF THE IMAGE	NATURE OF THE IMAGE
At infinity	At the focus F, behind the mirror	Highly diminished, point-size	Virtual and erect
Between infinity and pole P of the mirror	Between P and F, behind the mirror	Diminished	Virtual and erect

See figure - 10.2

Index of Refraction, n
 $n=c/v$
 c : the speed of light in a vacuum 3×10^8 m/sec
 v : speed of light in the medium.
 n : medium's index of refraction

Centre of curvature - A lens, either a convex lens or a concave lens has two spherical surfaces. Each of these surfaces form a part of sphere. The centre of these two spheres are called centre of curvature represented by C and C.

Principal axis - Imaginary straight line passing through the two centres of curvature

Optical Centre - The central point of lens is its optical centre (O). A ray of light, when passes through 'O' it remains undeviated i.e. it goes straight.

Aperture -The effective diameter of the circular outline of a spherical lens.

Focus of lens - Beam of light parallel is principal axis, after refraction from 1) Convex lens, converge to the point on principal axis, denoted by F, known as Principal focus 2) Concave lens, and appear to diverge from a point on the principal axis, known as principal focus.

CONVEX LENS- A lens may have two spherical surfaces, bulging outwards, is called double convex lens (or simply convex lens. It is also known as converging lens

REFRACTION

Spherical Lens a transparent material bound by two surface, of which one or both surfaces are spherical, forms a lens.

CONCAVE LENS -A lens bounded by two spherical surfaces, curved inwards is known as double concave lens (or simply concave lens) It is also known as diverging lens because it diverges the light.

POSITION OF THE OBJECT	POSITION OF THE IMAGE	SIZE OF THE IMAGE	NATURE OF THE IMAGE
At infinity	At the focus F2	Highly diminished, point-size	Real and inverted
Beyond 2F1	Between F2 and 2F2	Diminished	Real and inverted
At 2F1	At 2F2	Same size	Real and inverted
Between F1 and 2 F1	Beyond 2F2	Enlarged	Real and inverted
At F	At infinity	Highly Enlarged	Real and inverted
Between P and F	Behind the mirror	Enlarged	Virtual and erect

See figure – 10.3

Object position	Image position	Size of image	Nature of image
At infinity	At the focus F1	Highly diminished point size	Virtual and erect
Between infinity and optical centre of the lens	Between F1 and O	diminished	Virtual and erect

See figure – 10.4

The degree of convergence or divergence of light ray achieved by a lens is known as power of a lens. It is defined as the reciprocal of its focal length Represented by P i.e. $P=1/f$. SI unit – Dioptre (D).

IMPORTANT FORMULAE

- Relationship between focal length and radius of curvature of a mirror $f=R/2$
- Mirror formula $1/v + 1/u = 1/f$ [V-image distance , U-object distance, f-focal length]
- Magnification produced by mirror $- h'/h = - v/u$
- Snell's law $\frac{n_2}{n_1} = \frac{\sin i}{\sin r} = {}_1n_2$
- Absolute refractive index $n = c/v$
- Lens formula $1/v - 1/u = 1/f$
- Magnification produced by lens $h'/h = v/u$
- Power of lens $P = 1/f$ when focal length is in cm's $P=100/f$ D

RAY DIAGRAMS

Fig 10.1

NATURE, IMAGE AND ITS FORMATION (CONCAVE MIRROR)

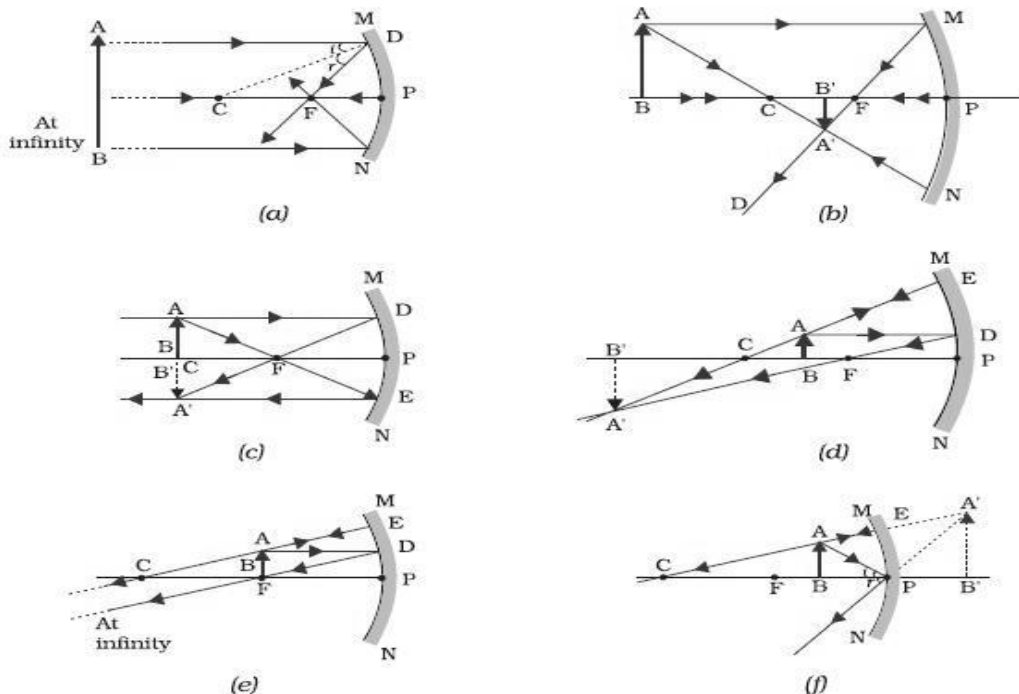

FIG – 10.2

NATURE, IMAGE AND ITS FORMATION (CONVEX MIRROR)

Object at infinity

Object between infinity and pole

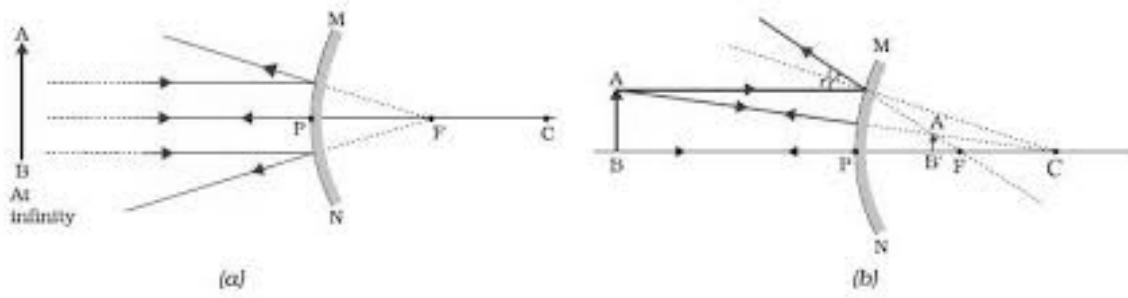

Fig- 10.3

NATURE, IMAGE AND ITS FORMATION (CONVEX LENS)

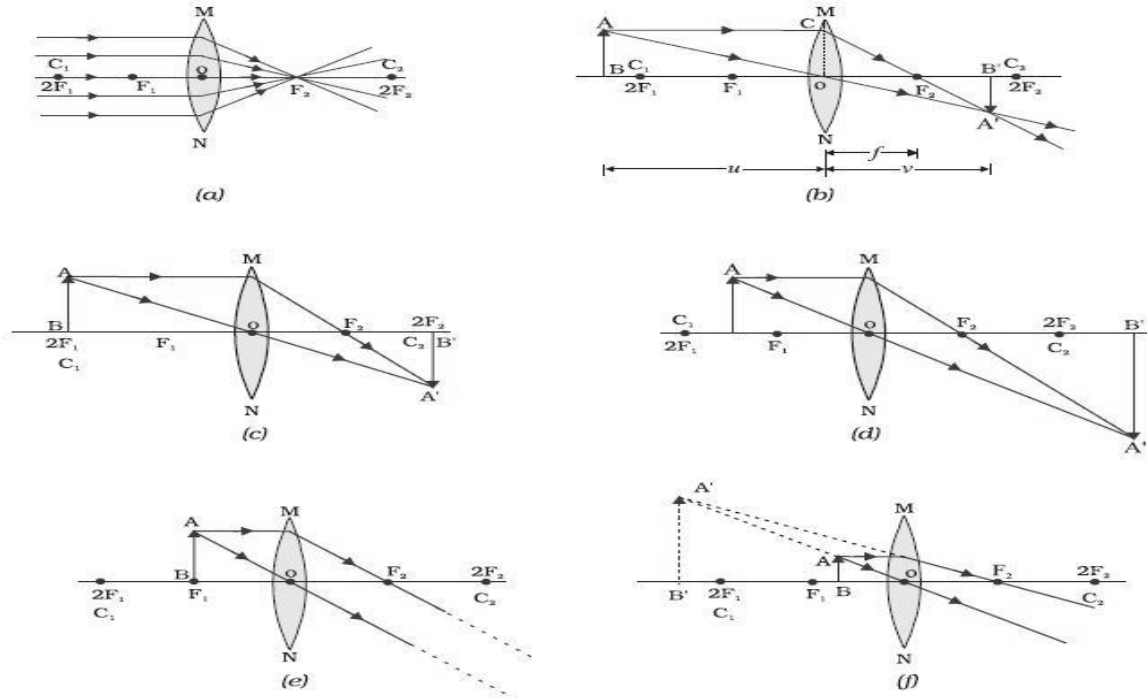
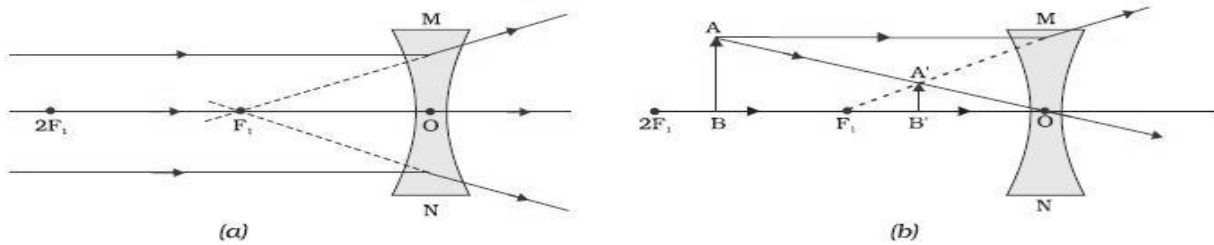

Fig-10.4

NATURE, IMAGE AND ITS FORMATION (CONCAVE LENS)



- a) Object at infinity
- b) Object (any point between infinity and O)

CROSSWORD

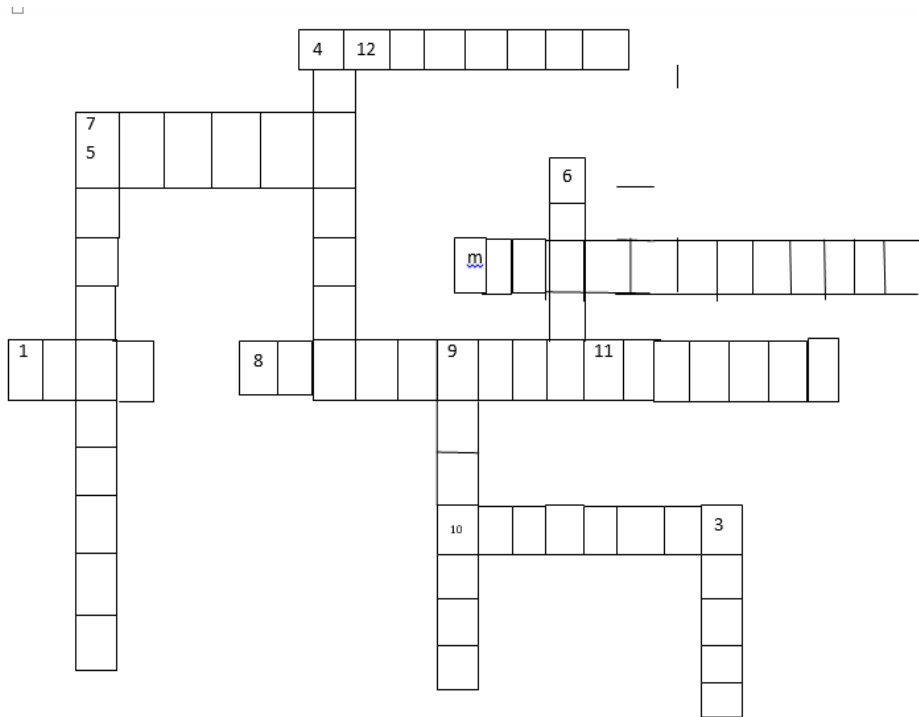

Across

- 1 A transparent medium bounded by the spherical surfaces.
- 2. Ratio of height of the image to the height of object
- 5. The medium where the speed of light is less.
- 8. An instrument which is used to see details of distant object.
- 10. The refractive index is equal to the reciprocal of sine of this angle.
- 11. Unit of power
- 12. The mirror used by dentist to see patient's teeth

Down

- 3. Form of energy that enables to see.
- 4. The nature of the image formed by the convex lens when the object is placed between optical centre and focus.
- 6. A converging lens.
- 7. The size of the image formed by the concave lens.
- 9. The lens having negative power

Answer the following questions (1 mark)

1. Refractive index of water is $\frac{4}{3}$ and that of the glass is $\frac{3}{2}$ with regard to air. What is the refractive index of glass with respect to the water? [Ans \blacktriangleright $\frac{9}{8}$]
2. What is the power of concave lens of focal length 200cm?
3. The radius of curvature of spherical mirror is 20cm. What is its focal length?
4. What is the angle of reflection when a ray of light fall normally on a plane mirror?
5. What is the magnification produced by the plane mirror.
6. What is the nature of image formed by concave mirror if magnification produce by mirror is +3.

Answer the following questions (2 mark)

1. An object 2cm high produce areal image 3 cm high , when placed at a distance of 15cm from concave mirror. Calculate the position of the image. (HOTS)
2. The power of a focal length is $-4D$. State the nature of lens and any two characteristics of the image formed by the lens.
3. State two examples based on phenomenon of refraction of light in everyday life situation.
4. Distinguish between real and virtual image.
5. Name the type of mirror used in the following situations:
 - a) Headlights of car
 - b) rear – view mirror of vehicles
6. An object is placed at a distance of 10 cm from convex mirror of focal length 15 cm. Find the position and nature of image.

Answer the following questions (3 mark)

1. The refractive indices of alcohol and turpentine oil with respect to air are 1.36 and 1.47 respectively. Find the refractive index of turpentine oil with respect to alcohol. In which of the two media the speed of light will be more.
2. a) Define power of a lens and give its unit.
 - b) A convex lens forms a real and inverted image of needle at a distance of 50cm from it. Where is the needle placed in front of this lens if the size of the image is equal to the size of the object? Also find power of the lens
3. Two thin lenses of focal lengths $+20$ cm and -15 cm are kept in contact. What is the focal length and power of the combination?
4. An object 2 cm high is placed at a distance of 16 cm from a concave mirror which produces a real image 3cm high.
 - a) Find the position of the image
 - b) What is the focal length of mirror?

VALUE BASED QUESTIONS

Four friends were on the way from Bangalore to Chennai .Nilesh was driving the car and saw from his mirror that the car which was behind their car had met an accident. He suddenly applies breaks His friends asked him to leave the situation as it is. But Nilesh did not agree and got down and asked his friend for help.

All of them took the injured person to the nearest hospital. After taking first aid from hospital the victim thanked them for saving his life.

Using above passage answer the following question

- a) Name the type of mirror from which Nilesh saw accident.
- b) Why this mirror is used as a side mirror in vehicles?
- c) What can you learn from Nilesh's character?

Answer the following questions (5 mark)

1. Draw a ray diagram in each of the following cases to show the formation of an image, when an object is placed

- a) Between optical centre and principal focus of a convex lens.
- b) Between F and 2F of concave lens
- c) At 2F of convex lens

Write the characteristic of image formed in each case.

2. A 1 cm tall object is placed perpendicular to the principal axis of a convex lens of focal length 20cm.The distance of the object from the lens is 15cm.Find the nature, position, size and magnification of the image. (HOTS)

3. Find the size, nature and position of image formed when an object of size 1 cm is placed at a distance of 15 cm from concave mirror of focal length 10 cm.

4. Draw the ray diagram for the different positions of the images formed by concave mirror.

CHAPTER 11-HUMAN EYE AND COLOURFUL WORLD

Power of accommodation:

- Ability of the eye lens to adjust its focal length.
- Relaxation of ciliary muscles → lens becomes thin → increase in focal length.
- Contraction of ciliary muscles → lens becomes thick → focal length decreases.

Near Point (N): The point at closest distance, at which an object can be seen clearly by the eye is called Near Point (N) of the eye. The distance of the near point of a normal eye is called the least distance of distinct vision. It is represented by d . For a normal eye, value of least distance of distinct vision is $d=25\text{cm}$.

Far Point (F): The most distant point at which an object can be seen clearly is called Far Point (F) of the eye. For a normal eye, far point lies at infinity.

Rods: Respond to the intensity of light and enable vision in dim light.

Myopia or Near-sightedness:

- Eye cannot see distant objects clearly.
- Image of distant object forms in front of retina.
- Reasons: (i) Excessive curvature of eye lens.
(ii) Elongation of eyeball

Correction: using concave lens

Hypermetropia or Far-sightedness:

- Eye cannot see nearby objects clearly.
- Image of object nearby forms behind retina.
- Reasons: (i) Focal length of eye lens is too long.
(ii) Eyeball becomes small

Correction using convex lens

Presbyopia:

- Eye suffers from myopia as well as from hypermetropia.
- Due to gradual weakening of ciliary muscles and diminishing flexibility of eye lens.
Correction using bifocal lens

Cataract: Milkiness of eye lens due to aging can be cured by surgery

Dispersion of Light:

Splitting of light into its component colours.

White light disperses into its seven-colour components in the order VIBGYOR (violet, Indigo, Blue, Green, Yellow, Orange, And Red).

Red light bends least, Violet the most.

Rainbow is formed due to refraction, dispersion and total internal reflection of sunlight by tiny droplets of water

Atmospheric Refraction: Refraction of light by the earth's atmosphere Twinkling of stars, Advanced sunrise, Delayed sunset, Flattening of disc of sun at sunrise and sunset are due to atmospheric refraction

Tyndall effect:

- When a beam of light strikes fine particles in air, path of the beam becomes visible.
- Very fine particles scatter mainly blue light while particles of larger size scatter light of longer wavelengths

DEFECTS OF VISION

S. No	Name of defect	Type of defect	Reason	Remedy
1.	Myopia	Nearsightedness	(i) Elongation of eye ball. (ii) excessive curvature of lens.	Use of concave lens.
2.	Hypermetropia	Farsightedness	(i) Longer focal length of eye lens. (ii) Shortening of eye ball.	Use of convex lens.
3.	Presbyopia	Decrease in power of accommodation	Ageing, leading to weak ciliary muscles and loss of flexibility of eye lens.	Use of eye glasses having bifocal lens.
4.	Cataract	Milkiensness of eye lens	Ageing, leading to partial or complete loss of eye sight.	Surgery.

SOME NATURAL PHENOMENON & CAUSES

S.No.	Phenomenon	Reason
1.	Multicolored light coming out of a triangular slab	Dispersion of light
2.	Rainbow	Refraction, dispersion of light and total internal reflection flight in rain drops
3.	Twinkling of stars, Advanced sunrise, Delayed sunset ,Flattening of disc of sun at sunrise and sunset	Atmospheric refraction of sunlight
4.	Blue colour of sky ,Reddening of sun at sun rise and sunset Tyndall effect	Scattering of light

Mind map

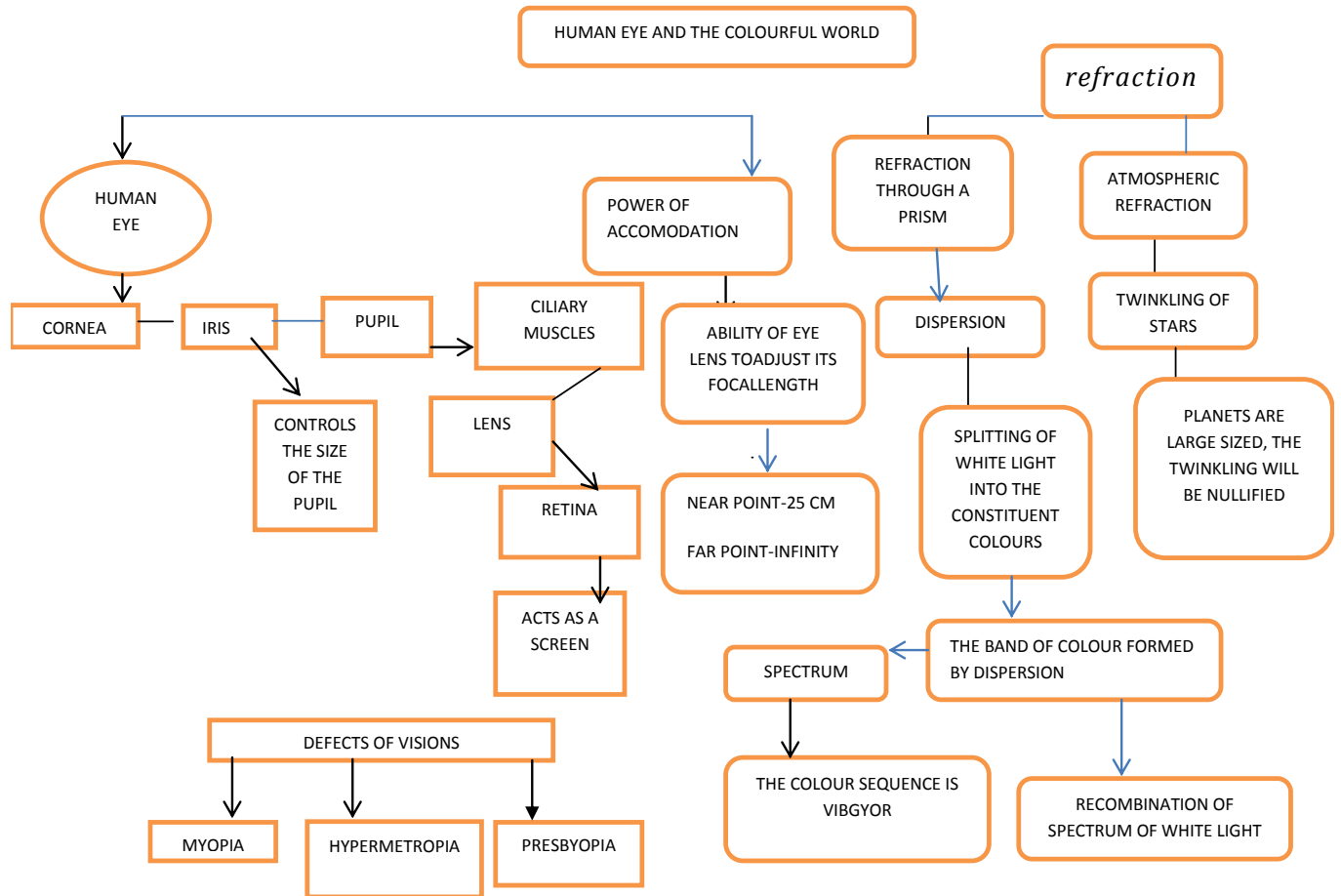

HUMAN EYE

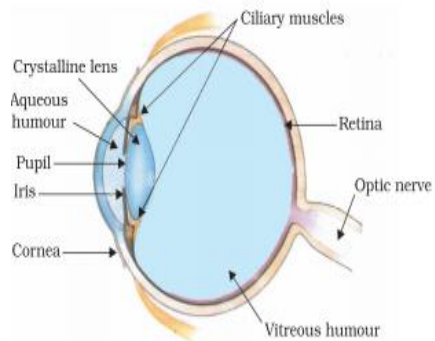

TWINKLING OF STARS

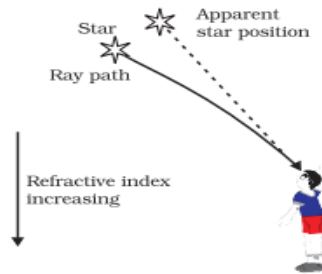
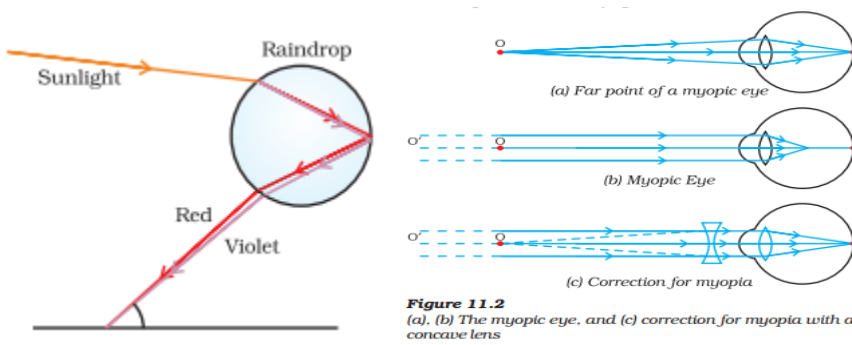
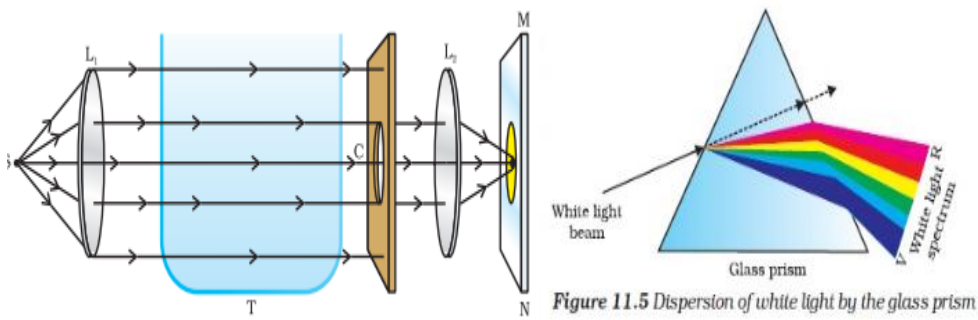

Figure 11.9
Apparent star position due to atmospheric refraction

FORMATION OF RAINBOW MYOPIA



SCATTERING OF LIGHT DISPERSION OF WHITE LIGHT



HYPERMETROPIA

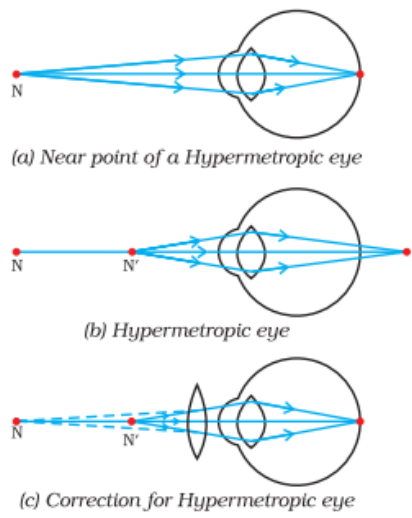

Figure 11.3
 (a), (b) The hypermetropic eye, and (c) correction for hypermetropia

RECOMBINATION

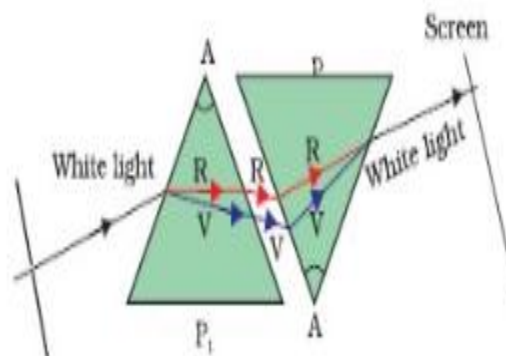

Figure 11.6 Recombination of the spectrum of white light

QUESTION BANK

1 mark questions (very short answer questions)

1. What is the far point and near point of the human eye with normal vision?
Answer: For normal vision, the near point is about 25cm and far point is infinity. Thus, a normal eye can see objects clearly that are between 25cm and infinity.
2. List the three phenomenon of light which is responsible for formation of rainbow in sky?
Answer: Refraction, dispersion and total internal reflection.

2markquestions

1. Why are 'danger' signal lights red in colour?
Answer: Danger signals are red in colour because the red coloured light having lower wavelength is scattered the least by fog or smoke. Therefore, it can be seen clearly from a distance.
2. Give reasons why the planets do not twinkle

Planets are much closer to the earth as compared to the stars they are bigger when we observe them from earth. Planets are made up of large number of point sources. Due to atmospheric refraction each point source will appear to twinkle, the total effect will be nullified.

Short Answer Type Questions (3marks)

1. A person needs a lens of power 4.5 D for correction of her vision.

- (a) What kind of defect in vision is she suffering from?
- (b) What is the focal length of the corrective lens?
- (c) What is the nature of the corrective lens?

Answer: (a) Hypermetropia. (b) $f = 1/4.5 = 0.22\text{m}$
(c) Convex lens

VALUE BASED QUESTION

Dolly and Ritu are two friends studying together in V grade. They prefer to sit together. Dolly is uncomfortable reading the blackboard when they are sitting on the last bench. Dolly is depressed fearing that she may turn blind one day. Ritu explains her that the problem may be due to some minor eye defect and there is no cause for worry. Dolly accompanied by Ritu visits the doctor who prescribes spectacles of suitable power for her. Dolly is now all smiles and thanks Ritu.

Read the above passage and answer the following questions:

- (i) What values are displayed by Ritu ?
- (ii) Name the defect of eye Dolly is suffering from.
- (iii) What could be the cause of this defect?

- (iv) The far point of Dolly is 50cm. What is the power of the lens she should use to read from the blackboard?

Answer: (i) Ritu has displayed concern for her friend. She is helpful

ii) Dolly is suffering from myopia or short sightedness.

(iii) Two possible causes of this effect are:

Increase in size of eye ball or decrease in focal length of eye lens.

(iv) Here, $x=50\text{cm}$ $f=-50\text{cm}$ $p=100/f=100/-50=-2\text{D}$

Long answer type questions (5mark)

1. Explain myopia and hypermetropia with the help of ray diagrams and show how these defects can be corrected?

Answer: (a) Explanation of Myopia and Hypermetropia

(b) Fig.11.2&11.3 NCERT TEXTBOOK

(c) The type of lens: Concave lens, convex lens

2. What is meant by dispersion and recombination? Explain with the help of a diagram? What is a spectrum? Name the various colours of spectrum of white light in proper sequence.

Answer: The splitting of white light into its component colours on passing through a prism is called dispersion. When an inverted prism is kept in the path of these seven colours, they combine to form white light. This is called recombination. The band of seven colours formed due to dispersion of white light is called 'spectrum'. Seven colours of spectrum are violet, indigo, blue, green, yellow, orange and red also known as 'VIBGYOR'

(Fig11.5&11.6 NCERT TEXT BOOK)

CHAPTER15- OUR ENVIRONMENT

GIST OF THE LESSON/FLOW CHART

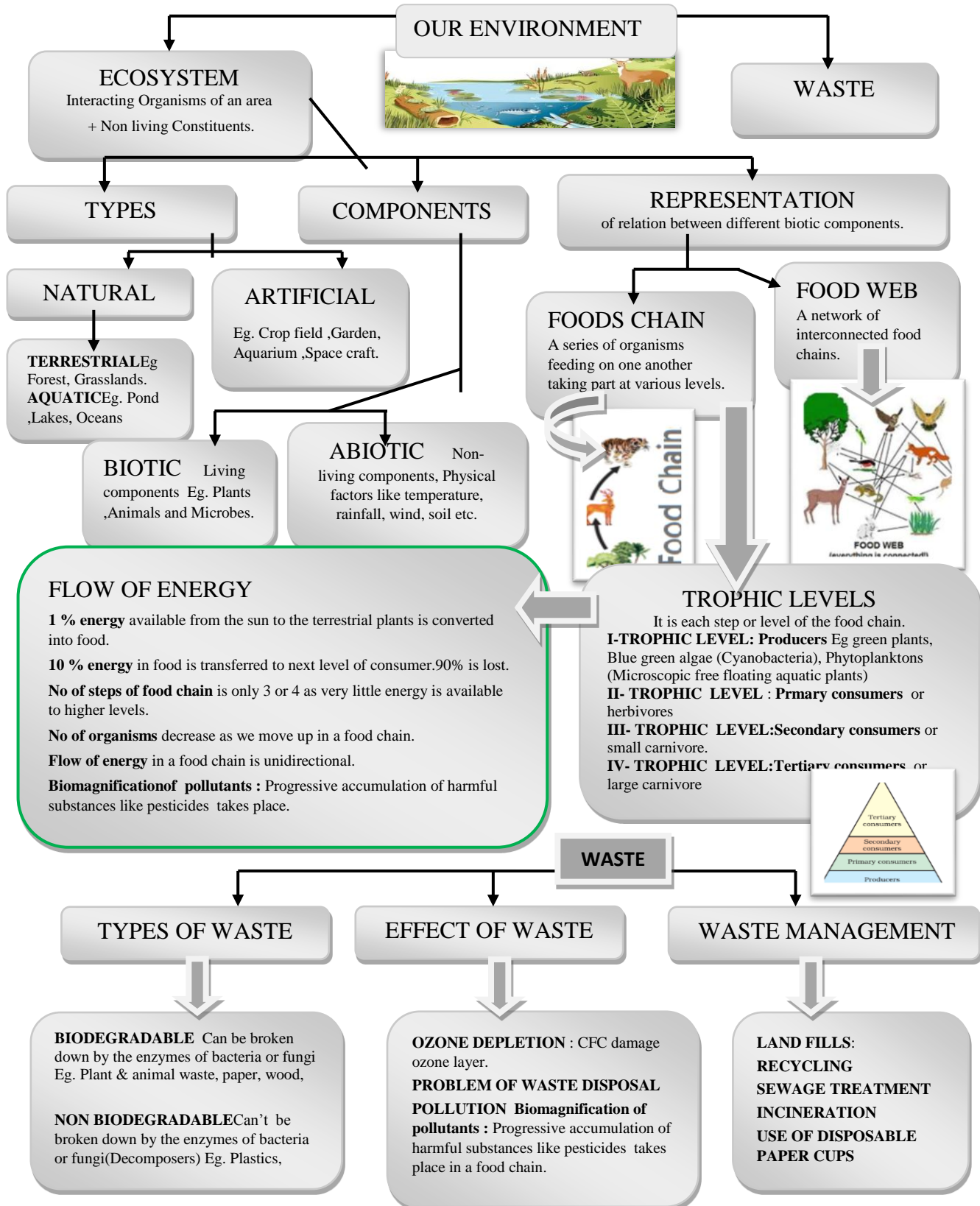

Environment: Our surrounding is called environment.

- Ecosystem and its components
- Biotic and abiotic components.
- Food chain and food web
- Energy transfer through trophic levels
- Ozone layer and its concerns.

Ecosystem: This is a system of interdependencies among various living beings and non-living things in a given habitat.

Components of Ecosystem: An ecosystem has two types of components, viz. biotic component and abiotic component.

Abiotic Component All the non-living things make the abiotic component of an ecosystem. Air, water and soil are the abiotic components.

Biotic Component All living beings make the biotic component of an ecosystem.

- Green plants play the role of producers; because they prepare the food by photosynthesis.
- Animals and other living beings play the role of consumers; because they take food (directly or indirectly) from plants.
- Bacteria and fungi play the role of decomposers; as they decompose dead remains of plants and animals so that raw materials of organisms can be channelized back to the environment.

Food Chain A food chain is a simple representation of transfer of energy from the sun to different biotic components of an ecosystem. Sun is the ultimate source of energy. Green plants convert solar energy into chemical energy during photosynthesis

Producer → Primary Consumer → Secondary Consumer

Food Web: In any ecosystem, there can be many food chains which are interlinked at various levels. Thus, many food chains form a network which is called food web.

Transfer of Energy through a food chain: Different levels in the food chain are called trophic level. Out of the energy consumed by an organism at a particular trophic level, 90% is utilised for its own need and rest 10% is left for the organism of the next trophic level.

Balance in the Ecosystem:

There is a delicate balance in an ecosystem; as far as number of organisms at a particular trophic level is concerned. An increase or decrease in population of any organism can disturb this balance. For example in the following food chain:



If all the deer are killed in a jungle, the lions would be left with no food. This would endanger the existence of lions. Once the lions and deer would be finished, it would result in population explosion of green plants. If all the lions die in a jungle, it would create another problem. Since no lion would be left to kill the deer, the population of deer would increase substantially. This will finish off all the green plants and finally even the deer would be left with no food for them.

Biodegradable Substances: Substances which can be decomposed by microorganisms are called biodegradable substances. All the organic substances are biodegradable.

Non-biodegradable: Substances which cannot be decomposed by microorganisms are non-biodegradable. All inorganic substances are non-biodegradable.

Ozone Layer Depletion:

Ozone layer is also known as stratosphere. When ultraviolet radiations act on oxygen, the oxygen gets converted into ozone.



Ozone layer works like a protective shield for living beings.

Effect of CFCs: Use of CFCs (Chlorofluorocarbon) has damaged the ozone layer. It is used in refrigerators and aerosol spray.

Problems of Waste Disposal Plastic waste is a serious concern because plastic is non-biodegradable. Proper segregation of wastes before disposal helps us to save our environment.

Mind Map — Our Environment

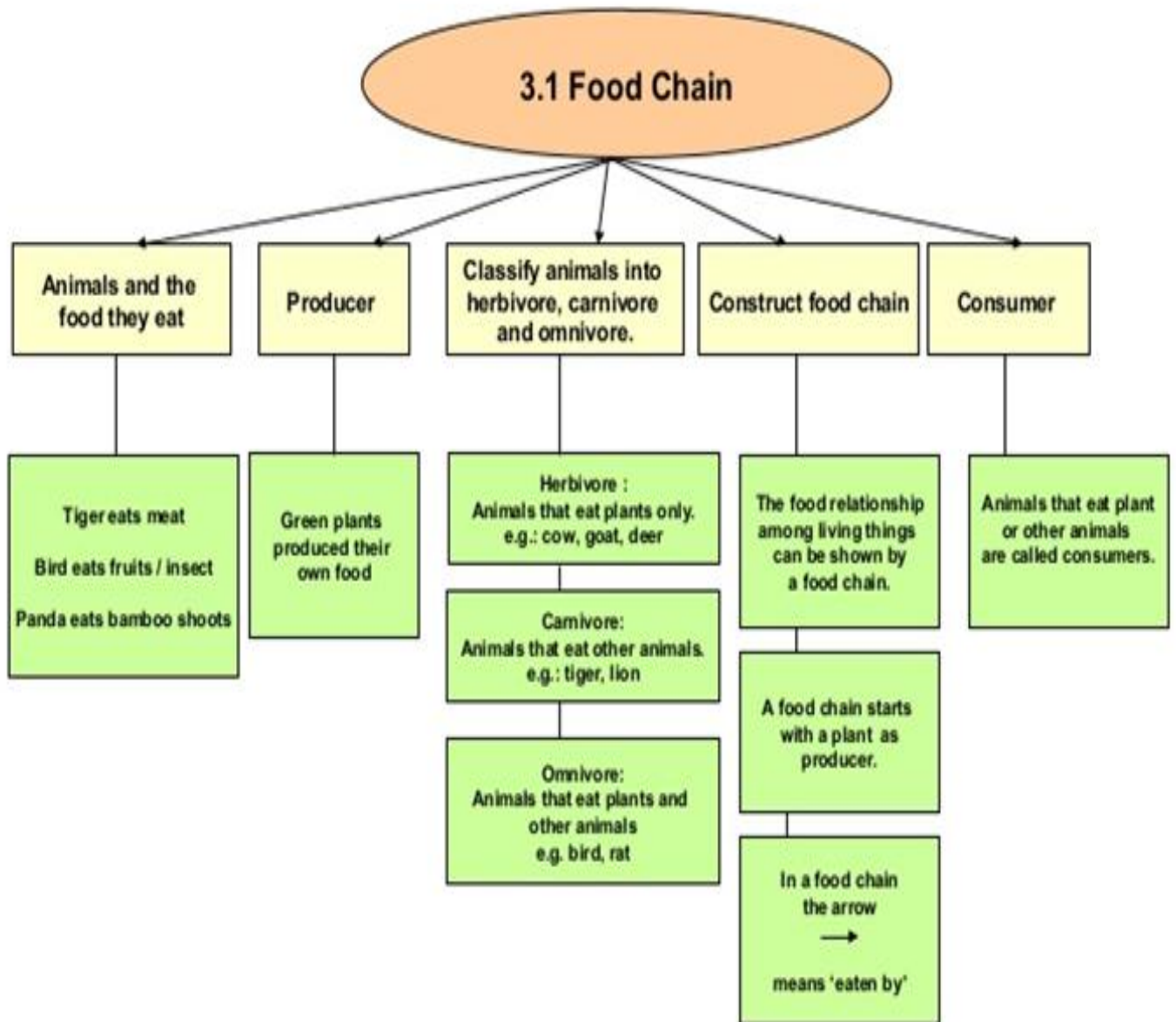

FLOW CHART

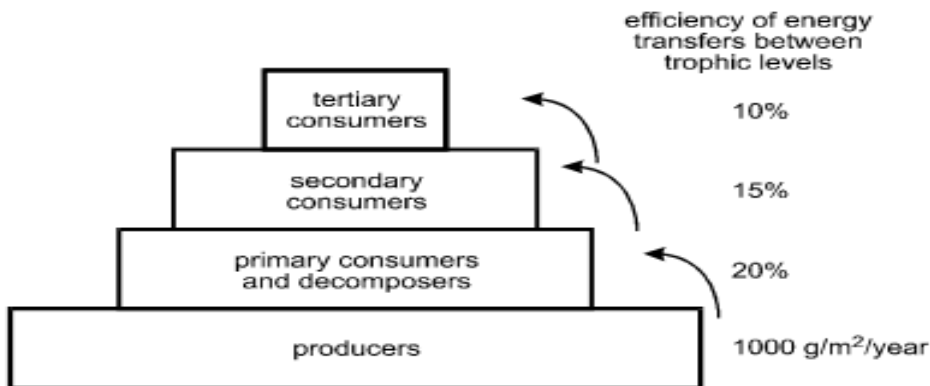
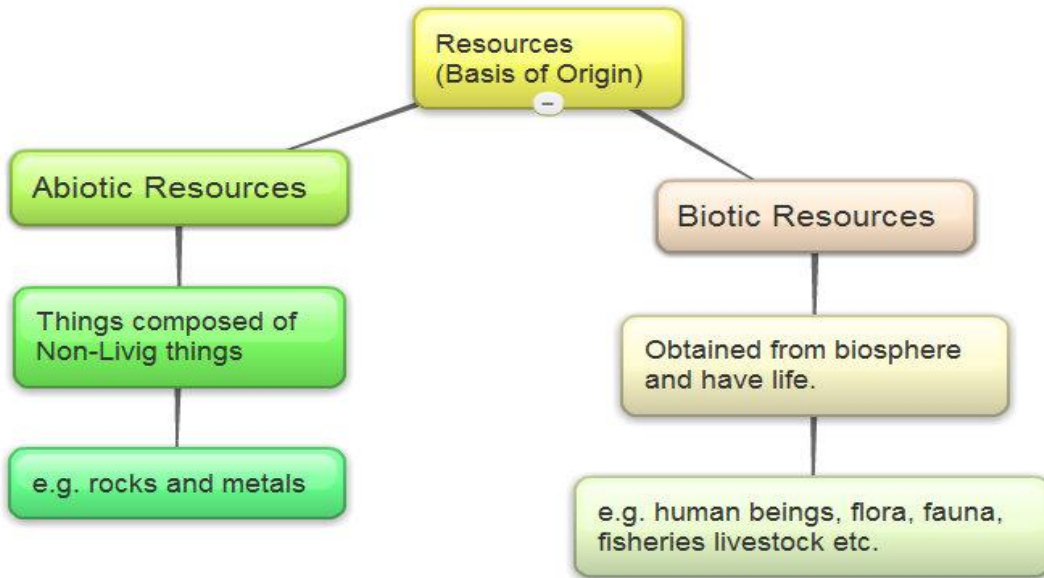
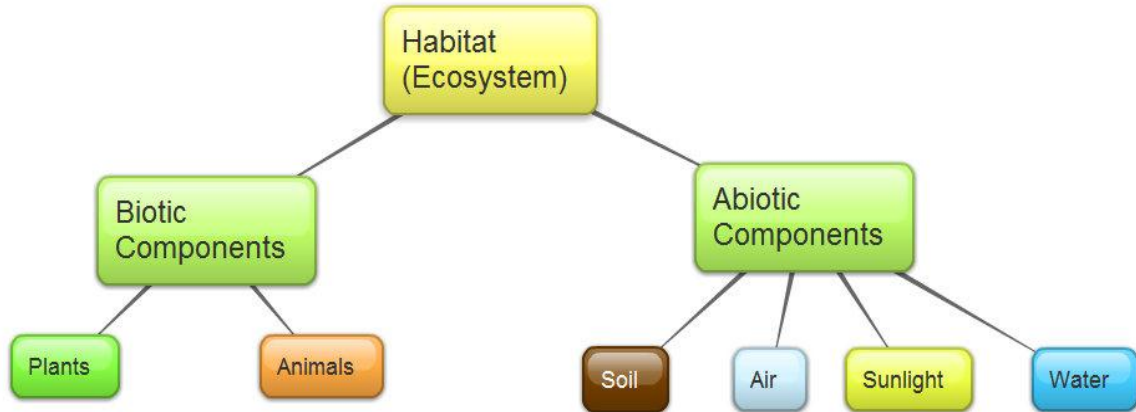

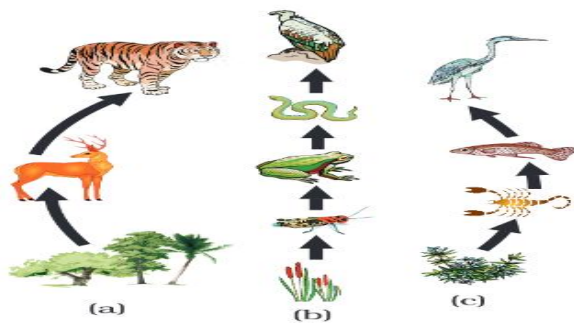

Figure 15.1
 Food chain in nature
 (a) in forest, (b) in
 grassland and (c) in a
 pond

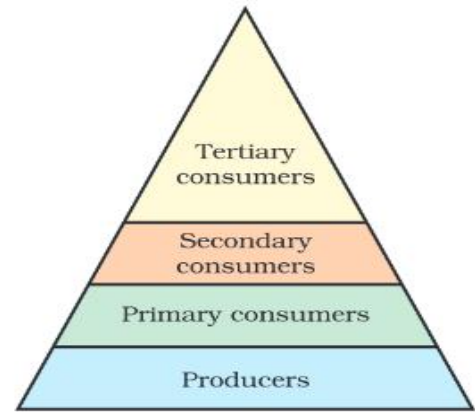

Figure 15.2
 Trophic levels

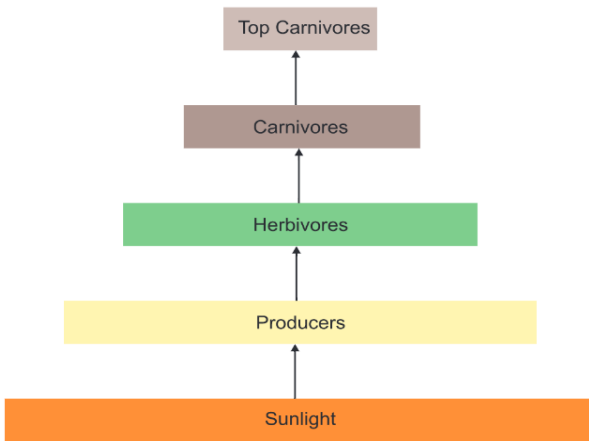
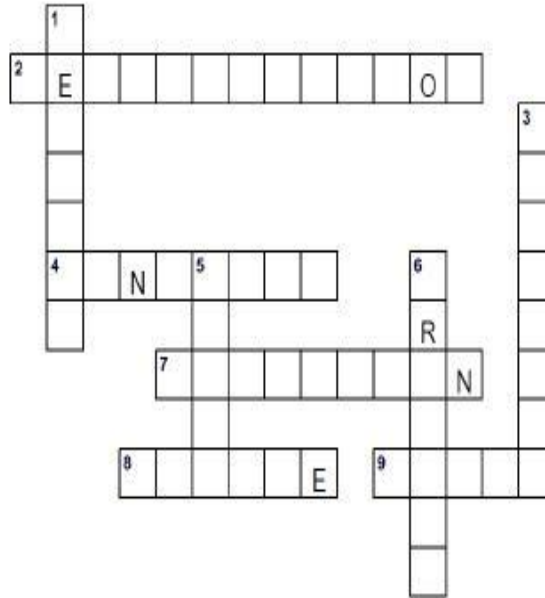

Figure 15.4 Diagram showing flow of energy in an ecosystem

ENVIRONMENT PUZZLE

Environment Puzzle

Using the Across and Down clues, write the correct words in the numbered grid below.



ACROSS

2. the act of cutting down or burning trees in a area
4. an area of land where large amounts of waste material are buried under the earth
7. something making land, water or sky dirty
8. to make less rubbish
9. to use something again

DOWN

1. to treat things that have already been used so they can be used again.
3. to keep safe from injury, harm, or destruction
5. a large number of water covering an area that is usually dry
6. to watch and help an animal or the environment

LANDFILL	RECYCLE	PROTECT	PRESERVE
POLLUTION	FLOOD	REDUCE	REUSE
DEFORESTATION			

ENVIRONMENT PUZZLE 2

Find the hidden words from the given grid. Words can go across or down.

M	S	C	W	R	I	L	T	C	B	O	O	S	N	M	S	U
S	T	H	R	S	E	O	P	A	E	C	O	M	P	O	S	T
V	E	S	E	H	O	F	O	A	A	E	N	X	T	U	R	T
T	R	P	Q	P	E	R	D	T	E	A	B	N	U	N	C	N
I	E	N	V	I	R	O	N	M	E	N	T	R	A	T	A	H
A	C	N	U	X	E	G	Y	O	G	T	R	B	Y	A	G	T
G	Y	K	I	J	C	S	Z	S	W	D	V	G	Y	I	O	K
O	C	Q	A	Z	L	B	V	P	A	S	C	I	E	N	C	E
L	L	Y	S	R	A	G	T	H	H	A	A	R	N	S	C	N
A	I	B	U	G	K	T	H	E	G	U	K	U	O	I	B	G
T	N	T	S	R	E	E	F	R	B	S	J	S	Y	O	I	B
A	G	G	F	T	S	E	G	E	A	R	T	H	R	S	Y	A
H	X	V	N	L	J	G	D	A	W	R	Y	I	P	L	I	J

Our Environment--- Question Bank

Q. 1 Using Kulhads as disposable cups to serve tea in trains, proved to be a bad idea. Why?

Ans. Making Kulhads on large scales leads to the loss of top soil.

Q. 2 Why is plastic not degraded by bacteria?

Ans. Plastic is not degraded by bacteria because they do not have enzymes to degrade plastic.

Q. 3 DDT has entered food chain. Which food habit is safer- vegetarian or nonvegetarian?

Ans. Vegetarian habit is safer. Being closer to producers, less DDT will accumulate in our body. Bio magnification leads to higher level of DDT in higher trophic levels.

Q. 4 Aquarium requires regular cleaning whereas lakes normally do not. Why?

Ans. Normally a lake has more diverse forms of life and hence a larger number of food chains. This leads to natural cleaning. Thus, the ecosystem is more stable. The aquarium has a very limited number of food chains and unable to sustain itself. But, sometimes there is excessive growth of algae in lake. Then it also needs to be cleaned.

Q. 5 How will accumulation of bio degradable waste effect our environment?

Ans. Accumulation of bio degradable waste will:

- (a) Not let minerals return to mineral pool.
- (b) Become site of pest breeding.

Q 6. Look at the following figures. Choose the correct one and give reason for your answer.

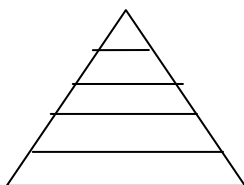

Fig "A"

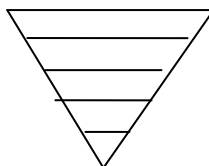

Fig 'B'

Ans :Fig. "A" is correct. • In an ecosystem, the number of individuals at producer level is maximum. This number reduces at each successive level. Therefore, the shape is a pyramid with broader base and tapering apex. • On an average 10% of the food changes into body mass and is available for the next level of consumers.

Q. 7 It is the responsibility of the government to arrange for the management and disposal of waste. As an individual you have no role to play. Do you agree? Support your answers with two reasons.

Ans. I do not agree. As an individual, I also have the responsibility and can contribute in the following ways:- (i) Cut down waste generation. (ii) Make compost pit for bio degradable waste. (iii) Recycle non biodegradable waste.

CHAPTER 16 : MANAGEMENT OF NATURAL RESOURCES

Natural resources include total natural environment that support human life and contribute to the production of necessities and comforts to mankind. So natural resources are the components of atmosphere, hydrosphere and lithosphere.

On the basis of abundance and availability, the natural resources are of two types:

- (a) Inexhaustible
- (b) Exhaustible.

We need to manage our natural resources because of the following reasons:

- 1. The resources of the earth are limited .*
- 2. The proper management of natural resources to prevent exploitation of natural resources*
- 3. The proper management can ensure equitable distribution of natural resources so that all the people can benefit from the development of these resources.*
- 4. The proper management will take into consideration the damage caused to the environment during the 'extraction' or 'use' of the natural resources and find ways and means to minimize this damage.*

Conservation of Wildlife

It is very important to conserve wild-life to maintain the ecological balance in nature and to preserve the gene pool.

- 1. Stringent laws to prevent poaching or capturing of animals.*
- 2. Preservation of habitat of wild animals preserved by establishing National Parks and sanctuaries*
- 3. Regular survey by Forest Department to learn about the population of all species of wild animals and plants*
- 4. Special attention should be paid to the conservation of endangered species of wild animals and birds to prevent their extinction altogether.*

Conservation of water:

Advantages of Dams:

- 1. Regular and round the year water supply to fields*
- 2. Continuous water supply to nearby human settlements*
- 3. Generation of electricity.*

Disadvantages of Dams:-

- 1. Social problems // 2. Environmental Problems// 3. Economic Problems*

Conservation of Forests:

1. Afforestation // 2. Reforestation// 3. Separation of Commercial Forestry//4. Grazing

Effects of Deforestation:- Removal, decrease or deterioration of the forest cover of an area is called deforestation. It is caused by excessive felling of trees, overgrazing, monoculture, fragmentation and clearing of forests.

Deforestation causes.

1. Soil Erosion.// 2. Desertification. //3. Floods/ /4. Destruction of wildlife//5. Climatic changes.

Chipko Movement:-

Chipko-Movement was born in Nineteen seventies in a small hilly village of the upper reaches of Himalayas. Tribal people of Tehri-Garhwal district of U.P realized the importance of the forests and decided against giving its products to the people of other areas. They stood against the ruthless butchery of nature and the axes of greedy contractors

Rainwater Harvesting:-

Water harvesting is capturing, collection and storage of rain water and surface run off for filling either small water bodies or recharging ground water so that water continues to be available in non-rainy seasons.

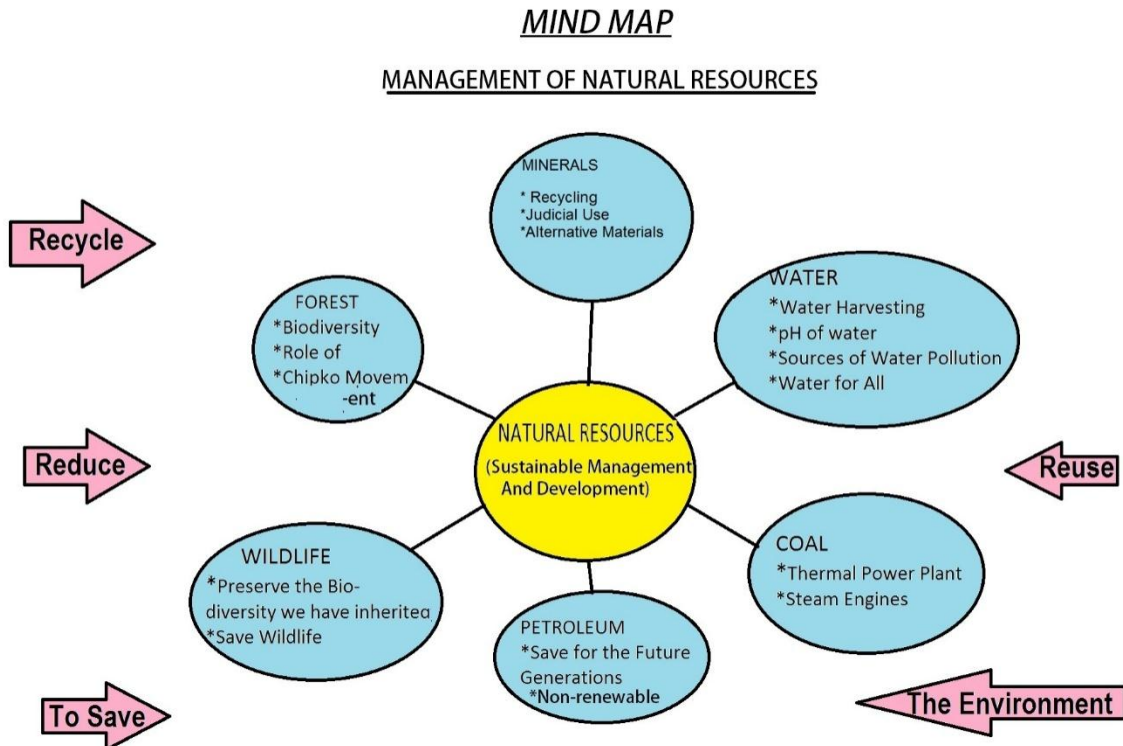

(see Fig. 16.1). Coliform is a group of bacteria, found in human intestines, whose presence in water indicates contamination by disease-causing microorganisms.

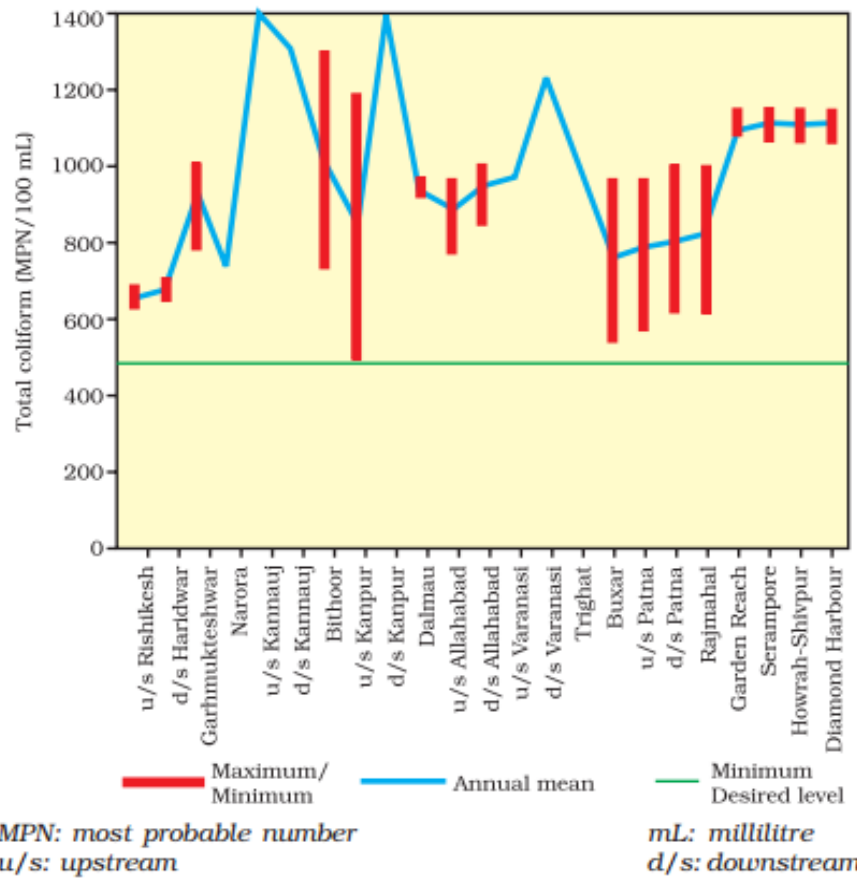

Figure 16.1 Total coliform count levels in the Ganga (1993-1994)

Source: Anon 1996, *Water Quality – Status and Statistics (1993 & 1994)*, Central Pollution Control Board, Delhi, p.11.

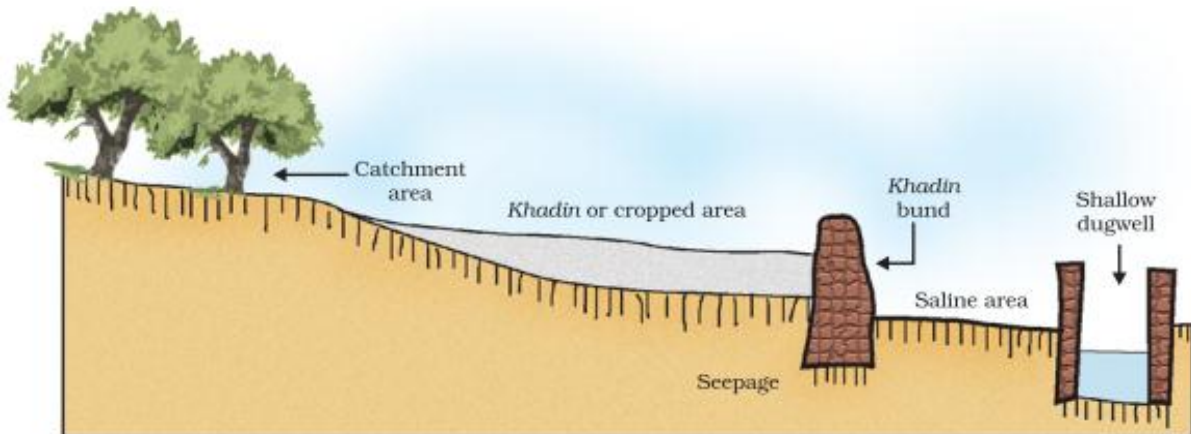

Figure 16.3 Traditional water harvesting system — an ideal setting of the khadin system

Very Short Answer Type Question(1 mark)

Q1.What is coliform?

Q2.What are the twokinds of natural resources?

Q3.What are the 3R's in sustainable development?

Short Answer Type Questions (2mark)

Q1.List any two common methods by which solid wastes of urban areas are disposed off?

Q2. State an instance where human intervention saved the forest from destruction.

Q3.Name the stakeholders who have their dependence on forests?

Short Answer Type Questions(3 Mark)

Q1.How is our holy river Ganga getting polluted? What are its ill effects? What is being done to prevent its pollution?

Q2.With the help of an example show that reuse strategy is better than recycling.

Q3.Why is sustainable management of natural resources necessary?

Q4.Everyone of us can do something to reduce our consumption of various natural resources. List 4 activities based on 3-R approach.

Value based question

There are certain NGOs which ask people to donate their used clothes, toys, school books, household items. These NGOs segregate the collected items and distribute them to needy people. What objectives do these NGOs fulfill by these initiatives?

PRACTICAL BASED QUESTIONS

1. In an experiment to study the properties of ethanoic acid, a student takes about 3 mL of ethanoic acid in a dry test tube. He adds an equal amount of distilled water to it and shakes the test tube well. After some time he is likely to observe that

- (a) A colloid is formed in the test tube.
- (b) The ethanoic acid dissolves readily in water.
- (c) The solution becomes light orange.
- (d) Water floats over the surface of ethanoic acid.

2. For preparation of soap in laboratory we require an oil and a base. Which of the following combinations of oil and a base would be best suited for the preparation of soap?

- (a) Castor oil and calcium hydroxide
- (b) Turpentine oil and sodium hydroxide
- (c) Castor oil and sodium hydroxide
- (d) Mustard oil and calcium hydroxide

4. A sample of water containing excess of calcium ion is called

- (a) Ionic water
- (b) Soft water
- (c) Hard water
- (d) Heavy water

3. A full length image of a distant tall building can be seen by using

- a) Concave mirror
- b) Convex mirror
- c) Plane mirror
- d) Both a and b

4. The magnifying power of convex lens

- a) Is always > 1
- b) Is always < 1
- c) Is always 1
- d) Can have any value

5. If the speed of light in a medium is 2×10^8 m/s, then its refractive index is:

- a) 1
- b) 10
- c) 1.5
- d) 0.5

6. You are given water, mustard oil, glycerine and kerosene. In which of these media a ray of light incident obliquely at same angle would bend the most?

- a) Kerosene

b) Glycerine

c) Water

d) Mustard oil

7. The law of reflection holds good for:

a) Plane mirror

b) Concave mirror only

c) All mirrors irrespective of their shape figure

d) Convex mirror only

8. A ray of light travelling in a rare medium meets the surface of another denser medium. While entering the second medium at the point of incidence, it

a) Goes straight into the second medium

b) Bends towards the normal

c) Bends away from the normal

d) Does not enter at all

9. In solar devices, the energy is concentrated into small area using

a) Plane mirror

b) Concave mirror

c) Parabolic mirror

d) Parabolic or concave mirror

10. Image formed in a photographic camera is

a) Virtual and diminished

b) Real and magnified

c) Sometimes real and sometimes virtual

d) Real and diminished

11. In the following diagram, the structure of embryo of a dicot seed is shown. In this the parts A and B are sequentially labelled.

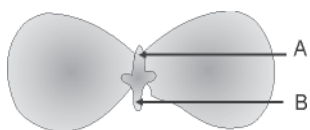

Choose the correct option:

- a) Plumule and radicle
- b) Cotyledon and seed coat
- c) Radicle and plumule
- d) None of these

12. What do the following diagram indicate:

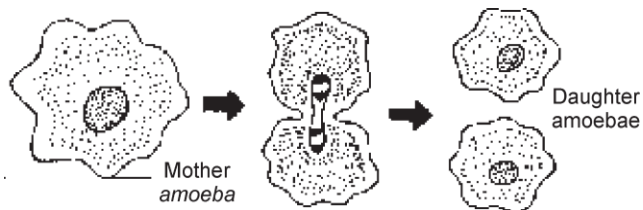

- a) Budding in yeast
- b) Binary fission in amoeba
- c) Multiple fission in plasmodium
- d) None of these

13. For tracing the path of a ray of light through a glass prism, the ideal distance between the two pins is:

- a) 2-3cm
- b) 3-5cm
- c) 6-8cm
- d) 10-15 cm

14. The basic cause of dispersion of white light on passing through a prism is:

- a) Same wavelength of different colours
- b) different wavelength of different colours
- c) Different colours travel through glass prism with same speed
- d) None of these

15. Wings of an insect and bird are example of

- a) Analogous organ
- b) Homologous organ
- c) Vestigial organ
- d) Analytic organ

16. Which of the following is/are example of vestigial organ/organs in humans?

- a) cornea
- b) Appendix
- c) Canine
- d) all of the above

SAMPLE QUESTION PAPER

BLUE PRINT FOR SA 1- (2015-2016)

S.NO	Chapter name	PBQ	VSA	SA1	SA2	LA	TOTAL
------	--------------	-----	-----	-----	-----	----	-------

1	Chemical reactions and equations	2 (1)	1(1)		2(3)		5(9)
2	Acids,bases and salts	2 (1)		2(2)		1(5)	5 (11)
3	Metals and non metals	1(2)*			2(3)	1(5)	4(13)
4	Life process	3 (1)		1(2)	1(3)	1(5)	6(13)
5	Control and coordination				1 (3)	1(5)	2(8)
6	Electricity	2 (1)2(2)*			2 (3)	1(5)	7 (17)
7	Magnetic effects of electric current		1(1)		2(3)	1(5)	4(12)
8	Sources of energy		1(1)		2(3)		3(7)
		12(15)	3(3)	3(6)	12(36)	6(30)	

*PBQ carrying two marks.

QUESTION PAPER
KENDRIYA VIDYALAYA SANGATHAN
BENGALURU REGION

SUMMATIVE ASSESSMENT -1 (2015-2016)

CLASS : X

SUBJECT: SCIENCE

Time : 3hours

Max.marks :90

General Instructions :

- 1 .The question paper comprises of two sections, A and B. You are to attempt both the sections.
2. All questions are compulsory.
3. All questions of section A and all questions of section B are to be attempted separately.
4. Question numbers 1 to 3 in section A are one mark questions. These are to be answered in one word or in one sentence.
5. Question numbers 4 to 6 in section A are two marks questions .These are to be answered in about 30 words each.
6. Question numbers 7 to 18 in section A are three marks questions .These are to be answered in about 50 words each.
7. Question numbers 19 to 24 in section A are five marks questions .These are to be answered in about 70 words each.
8. Questions 25 to 36 in section B are practical based questions. .
Question numbers 25 to 33 are MCQ carrying one mark each,.
.For all the multiple choice questions,you are to select, one most appropriate response out of the four provided to you. Questions 34 to 36 are short answer type questions carrying two marks each

SECTION : A

1. Identify in the following reaction :

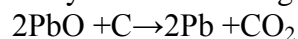

- d) the substance oxidised and
 - e) the substance reduced.
2. Name the rule which gives the direction of force experienced by a current carrying conductor when placed in a magnetic field.
 3. Thermal power plants are set up near coal or oil fields. Give reason
 4. Why is the rate of breathing in aquatic organisms much faster than in terrestrial organisms?

P.T.O

5. When zinc metal is treated with a dilute solution of a strong acid, a gas is evolved, which is utilised in the hydrogenation of oil. Name the gas evolved. Write the chemical equation of the reaction and also write a test to detect the gas formed.

- 6.. A compound which is prepared from gypsum has the property of hardening when mixed with proper quantity of water. Name the compound. How is it prepared? For what purpose is it used in hospitals ?
7. Illustrate the different pathways in the breakdown of a glucose molecule.
- 8.. Answer the following:-
- Which gland secretes digestive enzymes as well as hormones ?
 - Which endocrine gland is present in females , but absent in males ?
 - Name the hormone essential for carbohydrate, protein and fat metabolism
9. a) Oil and fat containing food items are flushed with nitrogen while packing them. Why?
b) Why do we apply paint on iron articles?
- 10.a) State two properties of gold which are extreme use to jewellers.
b) Name one metal and non-metal which exists in liquid state at room temperature.
c)Why do we use copper and aluminium wire for the transmission of electric current
- 11.Explain with electronic dot structure the formation of $MgCl_2$ by ionic bonding.
- 12.Write the balanced chemical for the following and identify the type of reaction in each case.
- Zinc carbonate(s) \longrightarrow Zinc oxide+ Carbon dioxide
 - Potassium bromide(aq) + Barium iodide(aq) \longrightarrow Potassium iodide+Barium bromide
13. What is solar cell panel ? List two advantages and disadvantages each of using solar cells for producing electricity .
- 14.What are the environmental consequences of the increasing demand for energy? What steps you suggest to reduce energy consumption?
- 15.a) What do you mean by magnetic effect of electric current?
b) State Right hand thumb rule.
16. What is solenoid? Draw magnetic field lines for a current carrying Solenoid.
17. One day Suresh connected many household power appliances having a current rating more than 6A to a multi-plug of 6A rating. When he was about to switch them on, his elder sister shouted and asked him to remove the appliances from a single socket.
- According to you, why she would not advice to connect multi-high power appliances on a single socket?
 - What would have happened, if he switched them on?
 - What was the value shown by his sister?
18. Two lamps, one rated 100W at 220V and other 60W at 220V are connected in parallel to the electric supply at 220V.
- Draw a circuit diagram to show the connections.
 - Calculate the total current drawn from the electric supply.

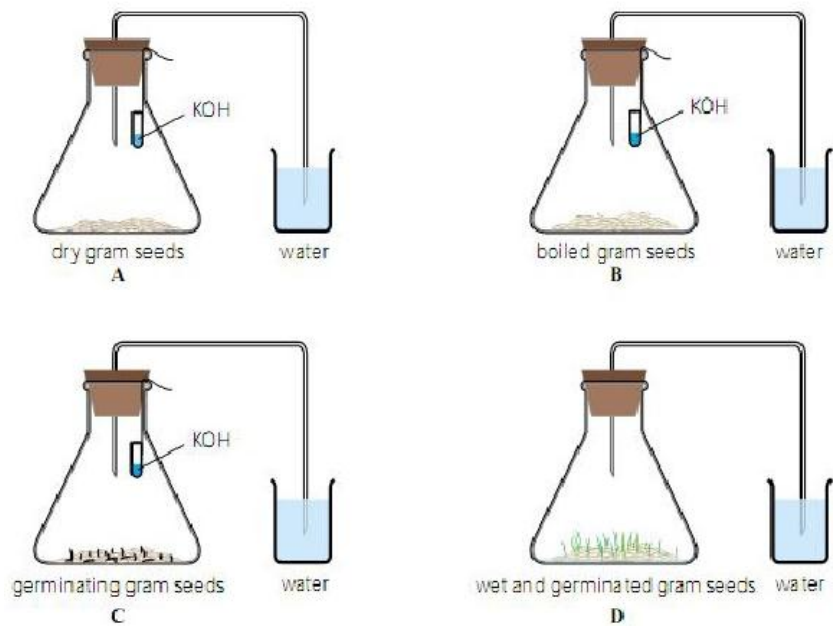

32) The following diagram shows the stomatal apparatus as observed in the mounted slide. Its parts have been labelled with numbers. Which number denotes chloroplast

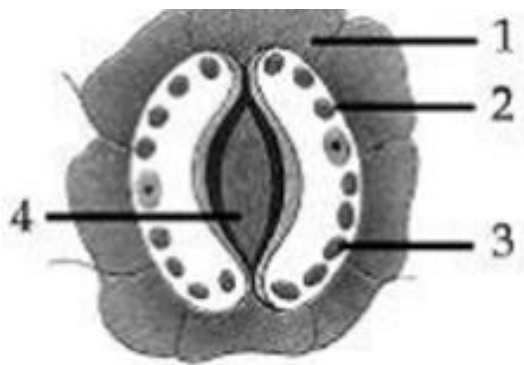

- a) 1 b) 2 c) 3 d) 4

33. For the circuits shown in figure-1 and figure-2 the ammeter reading would be :

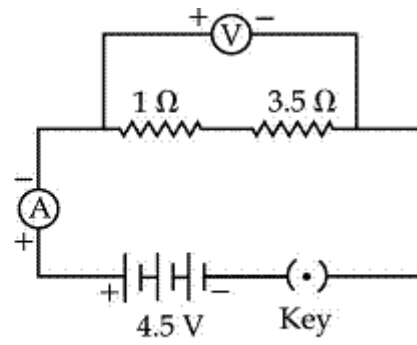
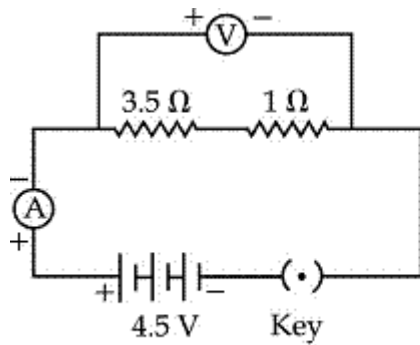

- a) 1.0A in figure 1 and 0.0A in figure 2
- b) 0.0A in both
- c) 1.0A in both
- d) 1.0A in figure 1 and 1.0A in figure 2

34. In the circuit I two resistors, each of $2\ \Omega$ are connected in series and in circuit II two resistors each of $2\ \Omega$ are connected in parallel. The potential difference across the two terminals of the battery in both the circuit are 4.5V. What will be the ammeter reading in circuit I and circuit II?

In the circuit I and II given below : The ammeter readings would be

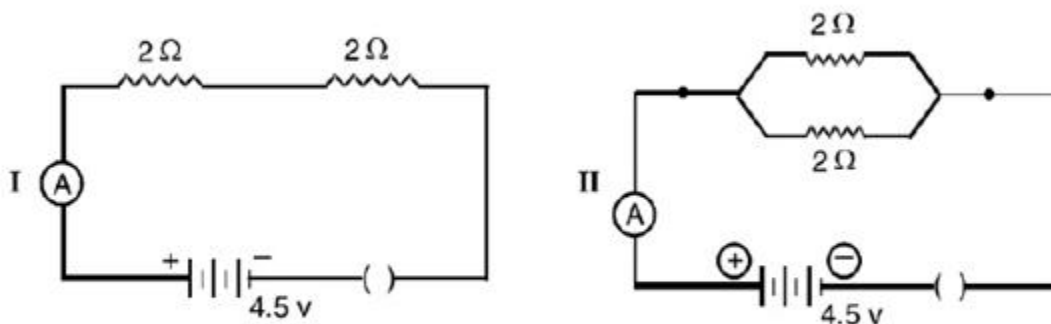

- (a) 0 A in circuit I and 4.5 A is in circuit II
- (b) 4.5 A in both the circuits

35. Name the physical quantity which is equal to the ratio of potential difference and current in the experiment to study the relationship between these two factors. State the law which is the outcome of this experiment.

36. Solution of CuSO_4 and FeSO_4 are placed in I and II test tubes respectively. Few pieces of Al are added to each solution. What will be the observations?

MARKING SCHEME FOR S A 1
CLASS: X
SUBJECT: SCIENCE

1.a) Carbon (1/2)

b) Lead oxide (1/2)

2. Fleming's left hand rule

3. To reduce the cost of transportation of coal from coal mines to thermal Power plants and thus to produce electricity with less cost. (1)

4. O_2 is less in water (1)

5. Hydrogen (1/2)

Any one correct equation



Bring burning splinter near the evolved gas, it burns with pop sound. (1/2)

6. Plaster of Paris. (1/2)

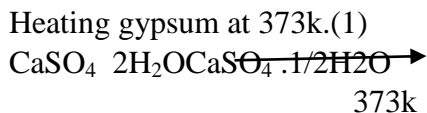

For immobilising fractured bones(1/2)

- 7) Three correct steps as given in the text book(1+1+1)
- 8) i) Pancreas (1)
 ii) Ovaries (1)
 iii)Thyroxine (1)
9. a)Oxidation of fatty acids leads to bad smell and taste due to rancidity. To prevent rancidity. Oil containing food items are flushed with nitrogen gas.(1+1/2)
 b) To prevent rusting.(1)
- 10.a) Malleability and ductility. (1)
 b) Metal –Mercury (1/2)
 Non-metal-bromine (1/2)
 c) Good conductors of electricity.(1)
11. Correct explanation with dot structure(3)
12. a) $\text{ZnCO}_3 \xrightarrow{\hspace{2cm}} \text{ZnO} + \text{CO}_2$ (DECOMPOSITION REACTION)(1+1/2)
 b) $2\text{KBr} + \text{BaI}_2 \xrightarrow{\hspace{2cm}} 2\text{KI} + \text{BaBr}_2$ (Double displacement reaction) (1+1/2)
13. Combined arrangement of number of solar cells (1)
 Two advantages: pollution free, inexhaustible source of energy, low Maintenance (1/2+1/2)
 Two disadvantages: High cost of installation, limited availability of special grade silicon, low efficiency(1/2+1/2)
14. Consequences
 1. Global warning(1/2)
 2. Pollution(1/2)
 3. Depletion of ozone umbrella (1/2)
- Stepstoreduce
 1. Judicious use of energy resources.(1/2)
 2. Use of alternative souce of energy should be encouraged (1/2)
 3. Increasing the efficiency of available source of energy with the help of Science and technology.(1/2)
15. When current passes through a wire it behaves like a magnet.(1)
 Right thumb rule definition (2)
16. Insulated copper wire wound in the form of a cylinder.(1)
 Neat labelled diagram (2)
- 17.a)Circuit will draw large amount of current leading to heating up of circuit
 Wires, which may lead to sparks and fire. (1)
 b) Overloading of circuit (1)
 c) Good knowledge of physics, scientific attitude and temper (any one)(1)
18. Correct circuit diagram (1)
 $P=VI$ (1/2)
 Current flowing through 100W $I_1 = P/V = 100/220$ (1/2)
 Current flowing through 60W $I_2 = P/V = 60/220$ (1/2)
 Current flowing through the circuit $I = I_1 + I_2 = 160/220 = 8/11$ A (1/2)

19. a) Process of purification of metals (1)
 b) Explanation for electrolytic refining of copper. (1+1/2)
 Correct diagram (1+1/2)
 c) Copper and tin (1/2+1/2)
20. a) i) A: most acidic C: most basic (1/2+1/2)
 ii) $C < B < D < A$ (1)
 iii) in C blue and in D green (1/2+1/2)
 b) Dry ammonia does not have OH^- ions. Solution of ammonia produces OH^- ions in water. OH^- ions are responsible for basic character. (2)
21. a) Definition Electric power (2)
 b) $1 \text{ kWh} = 3.6 \times 10^6 \text{ J}$ (1)
 c) Rs. 1732.5 (1)
22. a) Correct neat diagram (1+1/2)
 Labelling (1+1/2)
 b) Enzymes are secreted when food is taken in and they are secreted in Inactive form. Mucus layer present in the inner wall of the alimentary Canal protect it from the action of digestive enzymes. (any one point) (2)
23. Correct definition (1)
 Neat labelled diagram (2)
 Sensory nerves transmit electrical impulses from sense organs to central nervous system. (1)
 Motor nerves transmit impulses from CNS to effector organs. (1)
24. a) Device which convert mechanical energy to electrical energy. (1)
 b) Definition of electromagnetic induction (2)
 c) Importance of earthing (2)
25. a) Green
26. a) Hissing sound and solution becomes hot.
27. b) Copper
28. c) iii
29. b) A is sodium carbonate solution, B is acetic acid
30. b) 7.5V
31. c)
32. c) 3
33. c) 1A in both
34. a)
35. Resistance (1/2)
 Definition of ohms law (1+1/2)
36. Blue copper sulphate solution changes to colourless aluminium sulphate Solution. (1)
 Green iron sulphate solution changes to colorless aluminium sulphate Solution. (1)

Series JSR

SET-1

कोड नं. **31/1**
Code No.

रोल नं.

--	--	--	--	--	--	--

Roll No.

परीक्षार्थी कोड को उत्तर-पुस्तिका के मुख-पृष्ठ पर अवश्य लिखें।

Candidates must write the Code on the title page of the answer-book.

- कृपया जाँच कर लें कि इस प्रश्न-पत्र में मुद्रित पृष्ठ 16 हैं।
- प्रश्न-पत्र में दाहिने हाथ की ओर दिए गए कोड नम्बर को छात्र उत्तर-पुस्तिका के मुख-पृष्ठ पर लिखें।
- कृपया जाँच कर लें कि इस प्रश्न-पत्र में 36 प्रश्न हैं।
- कृपया प्रश्न का उत्तर लिखना शुरू करने से पहले, प्रश्न का क्रमांक अवश्य लिखें।
- इस प्रश्न-पत्र को पढ़ने के लिए 15 मिनट का समय दिया गया है। प्रश्न-पत्र का वितरण पूर्वाह्न में 10.15 बजे किया जाएगा। 10.15 बजे से 10.30 बजे तक छात्र केवल प्रश्न-पत्र को पढ़ेंगे और इस अवधि के दौरान वे उत्तर-पुस्तिका पर कोई उत्तर नहीं लिखेंगे।
- Please check that this question paper contains 16 printed pages.
- Code number given on the right hand side of the question paper should be written on the title page of the answer-book by the candidate.
- Please check that this question paper contains 36 questions.
- **Please write down the Serial Number of the question before attempting it.**
- 15 minute time has been allotted to read this question paper. The question paper will be distributed at 10.15 a.m. From 10.15 a.m. to 10.30 a.m., the students will read the question paper only and will not write any answer on the answer-book during this period.

संकलित परीक्षा - II
SUMMATIVE ASSESSMENT - II
विज्ञान
SCIENCE

निर्धारित समय : 3 घण्टे
Time allowed : 3 hours

अधिकतम अंक : 90
Maximum Marks : 90

सामान्य निर्देश :

- (i) इस प्रश्न पत्र को दो भागों, भाग अ और भाग ब, में बाँटा गया है। आपको दोनों भागों के प्रश्नों के उत्तर लिखने हैं।
- (ii) सभी प्रश्न अनिवार्य हैं।
- (iii) पूरे प्रश्न पत्र में किसी प्रश्न में कोई चयन प्राप्त नहीं है।
- (iv) आपको भाग अ और भाग ब के सभी प्रश्नों के उत्तर पृथक्-पृथक् भाग के आधार पर लिखने हैं।
- (v) भाग अ के प्रश्न संख्या 1 से 3 प्रश्न एक-एक अंक के हैं। इनके उत्तर एक शब्द अथवा एक वाक्य में दें।
- (vi) भाग अ के प्रश्न संख्या 4 से 6 के प्रश्न दो-दो अंकों के हैं। इनके उत्तर लगभग 30 शब्दों में देने हैं।
- (vii) भाग अ के प्रश्न संख्या 7 से 18 के प्रश्न तीन-तीन अंकों के हैं। इनके उत्तर लगभग 50 शब्दों में देने हैं।
- (viii) भाग अ के प्रश्न संख्या 19 से 24 के प्रश्न पाँच-पाँच अंकों के हैं। इनके उत्तर लगभग 70 शब्दों में देने हैं।
- (ix) भाग ब के प्रश्न संख्या 25 से 33 के प्रश्न प्रयोगात्मक कौशल पर आधारित बहुविकल्पी प्रश्न हैं। प्रत्येक प्रश्न एक अंक का है। दिए गए चार विकल्पों में से आपको केवल एक सबसे उपयुक्त विकल्प चुनना है।
- (x) भाग ब के प्रश्न संख्या 34 से 36 के प्रश्न प्रयोगात्मक कौशल पर आधारित दो-दो अंकों के प्रश्न हैं। इनके उत्तर संक्षिप्त में देने हैं।

General Instructions :

- (i) The question paper comprises **two** Sections, A and B. You are to attempt both the sections.
- (ii) All questions are **compulsory**.
- (iii) There is no choice in any of the questions.
- (iv) All questions of Section A and all questions of Section B are to be attempted separately.
- (v) Question numbers 1 to 3 in Section A are one-mark questions. These are to be answered in one word or in one sentence.
- (vi) Question numbers 4 to 6 in Section A are two-marks questions. These are to be answered in about 30 words each.
- (vii) Question numbers 7 to 18 Section A are three-marks questions. These are to be answered in about 50 words each.
- (viii) Question numbers 19 to 24 in Section A are five-marks questions. These are to be answered in about 70 words each.
- (ix) Question numbers 25 to 33 in Section B are multiple choice questions based on practical skills. Each question is a one-mark question. You are to select one most appropriate response out of the four provided to you.
- (x) Question numbers 34 to 36 in Section B are two-marks questions based on practical skills. These are to be answered in brief.

भाग - अ
SECTION - A

1. उस एल्कोहॉल का नाम और संरचना लिखिए जिसके अणु में तीन कार्बन परमाणु हैं। 1
Write the name and structure of an alcohol with three carbon atoms in its molecule.
2. क्या होता है जब कोई परिपक्व स्पाइरोगाइरा तन्तु काफी लम्बा हो जाता है? 1
What happens when a mature spirogyra filament attains considerable length ?
3. ओजोन परत की क्षति चिन्ता का विषय है। क्यों? 1
The depletion of ozone layer is a cause of concern. Why ?
4. सौर भट्टियों की अभिकल्पना में उपयोग होने वाले दर्पण का नाम लिखिए। इस युक्ति द्वारा उच्च ताप किस प्रकार प्राप्त किया जाता है, इसकी व्याख्या कीजिए। 2
Name the type of mirrors used in the design of solar furnaces. Explain how high temperature is achieved by this device.
5. "चिपको आन्दोलन" क्या था? इस आन्दोलन से अन्ततः स्थानीय लोगों और पर्यावरण को किस प्रकार लाभ हुआ? 2
"What was Chipko Andolan" ? How did this Andolan ultimately benefit the local people and the environment ?
6. "जीवाश्म ईंधन को जलाने से वैश्विक ऊष्मण होता है।" इस कथन की पुष्टि के लिए कारण दीजिए। 2
"Burning of fossil fuels results in global warming". Give reasons to justify this statement.

7. एथेनॉइक अम्ल की निम्नलिखित के साथ अभिक्रिया के रासायनिक समीकरण दीजिए : 3
 (a) सोडियम; (b) सोडियम हाइड्रॉक्साइड ; (c) एथेनॉल
 प्रत्येक अभिक्रिया में बने प्रमुख उत्पाद का नाम भी लिखिए।
 Write chemical equation of the reaction of ethanoic acid with the following :
 (a) Sodium; (b) Sodium hydroxide; (c) Ethanol.
 Write the name of one main product of each reaction.
8. किसी एल्डिहाइड और किसी कीटोन दोनों को समान अणु सूत्र, जैसे C_3H_6O द्वारा निरूपित 3
 किया जा सकता है। इनकी संरचनाएँ और नाम लिखिए। विज्ञान की भाषा में इन दोनों के बीच के संबंध का उल्लेख कीजिए।
 An aldehyde as well as a ketone can be represented by the same molecular formula, say C_3H_6O . Write their structures and name them. State the relation between the two in the language of science.
9. कोई तत्व 'X' आधुनिक आवर्त सारणी के तीसरे आवर्त और 16 वें समूह में स्थित है। 3
 (a) 'X' में संयोजकता इलेक्ट्रॉनों की संख्या तथा इसकी संयोजकता निर्धारित कीजिए।
 (b) 'X' की हाइड्रोजन के साथ अभिक्रिया द्वारा बने यौगिक का अणु सूत्र लिखिए तथा इसकी इलेक्ट्रॉन-बिन्दु संरचना खींचिए।
 (c) तत्व 'X' का नाम लिखिए तथा उल्लेख कीजिए कि यह तत्व धातु है अथवा अधातु है।
 An element 'X' belongs to 3rd period and group 16 of the Modern Periodic Table.
 (a) Determine the number of valence electrons and the valency of 'X'.
 (b) Molecular formula of the compound when 'X' reacts with hydrogen and write its electron dot structure.
 (c) Name the element 'X' and state whether it is metallic or non-metallic.
10. किसी तत्व 'X' की द्रव्यमान संख्या 35 तथा इसमें न्यूट्रॉनों की संख्या 18 है। 'X' की परमाणु 3
 संख्या और इसका इलेक्ट्रॉन-विन्यास लिखिए। 'X' की समूह संख्या, आवर्त संख्या और संयोजकता का उल्लेख भी कीजिए।
 An element 'X' has mass number 35 and number of neutrons 18. Write atomic number and electronic configuration of 'X'. Also write group number, period number and valency of 'X'.

11. जनन की परिभाषा लिखिए। स्पीशीज की समष्टि को स्थायित्व प्रदान करने में यह किस प्रकार सहायता करता है? 3

Define reproduction. How does it help in providing stability to the population of species?

12. जीवों के जनन के संदर्भ में उपयोग होने वाले पद “पुनरुद्भवन” (पुनर्जनन) की व्याख्या कीजिए। संक्षेप में वर्णन कीजिए कि हाइड्रा जैसे बहु कोशिक जीवों में ‘पुनरुद्भवन’ की प्रक्रिया किस प्रकार सम्पन्न होती है? 3

Explain the term “Regeneration” as used in relation to reproduction of organisms. Describe briefly how regeneration is carried out in multicellular organisms like Hydra.

13. (a) लैंगिक जनन द्वारा उत्पन्न संतति में विभिन्नता दृष्टिगोचर होने के दो कारणों की सूची बनाइए। 3

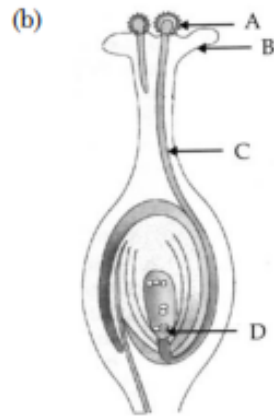

- (i) आरेख में अंकित भाग 'A' का नाम लिखिए।
(ii) 'A' भाग 'B' तक किस प्रकार पहुँचता है?
(iii) भाग 'C' का महत्व लिखिए।
(iv) 'D' द्वारा अंकित भाग का निषेचन के पश्चात क्या होता है?

- (a) List two reasons for the appearance of variations among the progeny formed by sexual reproduction.

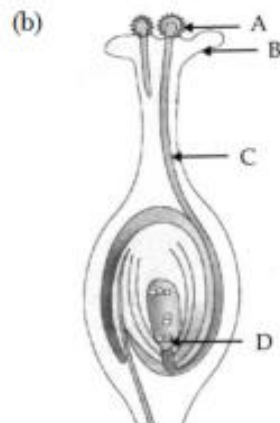

- (i) Name the part marked 'A' in the diagram.
 (ii) How does 'A' reaches part 'B' ?
 (iii) State the importance of the part 'C'.
 (iv) What happens to the part marked 'D' after fertilisation is over ?

14. मेंडल ने प्रयोगों द्वारा किस प्रकार दर्शाया कि लक्षण स्वतंत्र रूप से वंशानुगत होते हैं ? 3
 How do Mendel's experiment show that traits are inherited independently ?
15. "अध्ययन के दो क्षेत्र-'विकास' और 'वर्गीकरण' परस्पर जुड़े हैं।" इस कथन की पुष्टि कीजिए। 3
 "Two areas of study namely 'evolution' and 'classification' are interlinked". Justify this statement.
16. किसी दर्पण द्वारा बना प्रतिबिम्ब, वास्तविक, उल्टा और -1 आवर्धन का है। यदि प्रतिबिम्ब की दर्पण से दूरी 40 cm है, तो बिम्ब कहाँ स्थित है? यदि बिंब को दर्पण की ओर 20 cm स्थानान्तरित कर दिया जाए, तो प्रतिबिम्ब कहाँ बनेगा? अपने उत्तर की पुष्टि के लिए कारण दीजिए तथा बिम्ब की नई स्थिति के लिए किरण आरेख खींचिए। 3

The image of an object formed by a mirror is real, inverted and is of magnification -1 . If the image is at a distance of 40 cm from the mirror, where is the object placed? Where would the image be if the object is moved 20 cm towards the mirror? State reason and also draw ray diagram for the new position of the object to justify your answer.

17. यह दर्शाने के लिए किसी क्रियाकलाप का वर्णन कीजिए कि किस प्रकार एक प्रिज्म द्वारा विपाटित श्वेत प्रकाश को अन्य सर्वसम प्रिज्म द्वारा पुनर्योजित करके पुनः श्वेत प्रकाश प्राप्त किया जा सकता है। श्वेत प्रकाश के स्पेक्ट्रम के पुनर्योजन को दर्शाने के लिए किरण आरेख भी खींचिए। 3

Describe an activity to show that the colours of white light splitted by a glass prism can be recombined to get white light by another identical glass prism. Also draw ray diagram to show the recombination of the spectrum of white light.

18. मानव के क्रियाकलापों ने जीव मण्डल के जीव रूपों को बुरी तरह से प्रभावित किया है। मानव द्वारा प्रकृति के असीमित दोहन ने जीव-मण्डल के जैव एवं अजैव अवयवों के संवेदनशील संतुलन को अस्त-व्यस्त कर दिया है। मानव द्वारा स्वयं सृजित प्रतिकूल परिस्थितियों ने न केवल उसकी अपनी उत्तर जीविता को ललकारा है, बल्कि पृथ्वी के समस्त जीवों को भी ललकारा है। आपका एक सहपाठी जो आपके स्कूल के 'ईको क्लब' का सक्रिय सदस्य है स्कूल के छात्रों में पर्यावरण के प्रति जागरूकता उत्पन्न कर रहा है, तथा इसे समाज में भी फैला रहा है। वह पास-पड़ोस के पर्यावरण के निम्नीकरण को रोकने के लिए भी कठोर कार्य कर रहा है। 3

- (a) हमें अपने पर्यावरण का संरक्षण करना क्यों आवश्यक है?
- (b) घरेलू अपशिष्टों के निरापद निपटारे के लिए हरी और नीली कूड़ा-पेटियों का महत्व लिखिए।
- (c) आपके उस सहपाठी द्वारा प्रदर्शित दो मूल्यों की सूची बनाइए जो आपके विद्यालय के 'ईको क्लब' का सक्रिय सदस्य है।

The activities of man had adverse effects on all forms of living organisms in the biosphere. Unlimited exploitation of nature by man disturbed the delicate ecological balance between the living and non-living components of the biosphere. The unfavourable conditions created by man himself threatened the survival not only of himself but also of the entire living organisms on the mother earth. One of your classmates is an active member of 'Eco club' of your school which is creating environmental awareness amongst the school students, spreading the same in the society and also working hard for preventing environmental degradation of the surroundings.

- (a) Why is it necessary to conserve our environment ?
- (b) State the importance of green and blue dust-bins in the safe disposal of the household waste.
- (c) List two values exhibited by your classmate who is an active member of Eco-club of your school.

19. कोई कार्बन यौगिक 'P' आधिक्य सांद्र H_2SO_4 के साथ गर्म किए जाने पर कोई अन्य यौगिक 'Q' बनाता है जो निकेल उत्प्रेरक की उपस्थिति में हाइड्रोजन से संकलन करके कोई संतृप्त यौगिक 'R' बनाता है। 'R' का एक अणु, दहन होने पर, कार्बन डाइऑक्साइड के दो अणु तथा जल के तीन अणु बनाता है। P, Q और R को पहचानिए और सम्मिलित अभिक्रियाओं के रासायनिक समीकरण लिखिए। 5

A carbon compound 'P' on heating with excess conc. H_2SO_4 forms another carbon compound 'Q' which on addition of hydrogen in the presence of nickel catalyst forms a saturated carbon compound 'R'. One molecule of 'R' on combustion forms two molecules of carbon dioxide and three molecules of water. Identify P, Q and R and write chemical equations for the reactions involved.

20. प्लैसेन्टा क्या है? इसकी संरचना का वर्णन कीजिए। गर्भवती मानव मादा के प्रकरण में इसके कार्यों का उल्लेख कीजिए। 5

What is placenta ? Describe its structure. State its functions in case of a pregnant human female.

21. विकास की परिभाषा लिखिए। यह किस प्रकार होता है? वर्णन कीजिए कि जीवाश्म किस प्रकार विकास के समर्थन में प्रमाण प्रस्तुत करते हैं? 5
- Define evolution. How does it occur? Describe how fossils provide us evidences in support of evolution.
22. 12 cm फोकस दूरी के अवतल दर्पण द्वारा किसी बिम्ब का सीधा प्रतिबिम्ब बनाने के लिए कहा गया है। 5
- (i) दर्पण के सामने बिम्ब की दूरी का क्या परिसर होना चाहिए?
- (ii) बनने वाला प्रतिबिम्ब साइज में बिम्ब से छोटा होगा अथवा बड़ा? इस प्रकरण में प्रतिबिम्ब बनना दर्शाने के लिए किरण आरेख खींचिए।
- (iii) इस बिम्ब का प्रतिबिम्ब कहाँ बनेगा, यदि इसे दर्पण के सामने 24 cm दूरी पर रख दिया जाए? अपने उत्तर की पुष्टि के लिए इस स्थिति के लिए भी किरण आरेख खींचिए।
- उपरोक्त किरण आरेखों में ध्रुव, मुख्य फोकस और वक्रता केन्द्र की स्थितियों को भी दर्शाइए।
- It is desired to obtain an erect image of an object, using concave mirror of focal length of 12 cm.
- (i) What should be the range of distance of an object placed in front of the mirror?
- (ii) Will the image be smaller or larger than the object. Draw ray diagram to show the formation of image in this case.
- (iii) Where will the image of this object be, if it is placed 24 cm in front of the mirror? Draw ray diagram for this situation also to justify your answer.
- Show the positions of pole, principal focus and the centre of curvature in the above ray diagrams.
23. (a) गोलीय लेंस के प्रकाशिक केन्द्र की परिभाषा लिखिए। 5
- (b) किसी अपसारी लेंस की फोकस दूरी 20 cm है। 4 cm ऊँचाई के किसी बिम्ब को इस लेंस के प्रकाशिक केन्द्र से कितनी दूरी पर रखा जाना चाहिए कि इसका प्रतिबिम्ब लेंस से 10 cm दूरी पर बने। प्रतिबिम्ब का साइज भी परिकलित कीजिए।
- (c) उपरोक्त स्थिति के लिए प्रतिबिम्ब बनना दर्शाने के किरण आरेख खींचिए।

- (a) Define optical centre of a spherical lens.
- (b) A divergent lens has a focal length of 20 cm. At what distance should an object of height 4 cm from the optical centre of the lens be placed so that its image is formed 10 cm away from the lens. Find the size of the image also.
- (c) Draw a ray diagram to show the formation of image in above situation.

24. वायुमण्डलीय अपवर्तन क्या है? इस परिघटना का उपयोग करके नीचे दी गयी प्राकृतिक घटनाओं की व्याख्या कीजिए : 5

- (a) तारों का टिमटिमाना
 - (b) अग्रिम सूर्योदय और विलम्बित सूर्यास्त
- अपने उत्तरों के स्पष्टीकरण के लिए आरेख खींचिए।

What is atmospheric refraction ? Use this phenomenon to explain the following natural events.

- (a) Twinkling of stars
- (b) Advanced sun-rise and delayed sun-set.

Draw diagrams to illustrate your answers.

भाग - ब

SECTION - B

25. कोई छात्र साबुनीकरण अभिक्रिया के अभिक्रिया मिश्रण की एक बूंद पहले नीले लिटमस पत्र और फिर लाल लिटमस पत्र पर डालता है। वह यह प्रेक्षण करता है कि : 1

- (a) नीले लिटमस पत्र में कोई परिवर्तन नहीं होता और लाल लिटमस पत्र सफेद हो जाता है।
- (b) लाल लिटमस पत्र में कोई परिवर्तन नहीं होता और नीला लिटमस पत्र लाल हो जाता है।
- (c) नीले लिटमस पत्र में कोई परिवर्तन नहीं होता और लाल लिटमस पत्र नीला हो जाता है।
- (d) दोनों ही लिटमस पत्रों के रंग में कोई परिवर्तन नहीं होता।

A student puts a drop of reaction mixture of a saponification reaction first on a blue litmus paper and then on a red litmus paper. He may observe that :

- (a) There is no change in the blue litmus paper and the red litmus paper turns white.
- (b) There is no change in the red litmus paper and the blue litmus paper turns red.
- (c) There is no change in the blue litmus paper and the red litmus paper turns blue.
- (d) No change in colour is observed in both the litmus papers.

26. प्रयोगशाला में साबुन बनाने के लिए हमें कोई तेल और कोई क्षार चाहिए। साबुन बनाने के लिए तेल और क्षार का नीचे दिया गया कौन सा संयोजन सबसे उपयुक्त रहेगा ? 1

- (a) एरण्ड का तेल और कैल्सियम हाइड्रॉक्साइड
- (b) तारपीन का तेल और सोडियम हाइड्रॉक्साइड
- (c) एरण्ड का तेल और सोडियम हाइड्रॉक्साइड
- (d) सरसों का तेल और कैल्सियम हाइड्रॉक्साइड

For preparing soap in the laboratory we require an oil and a base. Which of the following combinations of an oil and a base would be best suited for the preparation of soap ?

- (a) Castor oil and calcium hydroxide
- (b) Turpentine oil and sodium hydroxide
- (c) Castor oil and sodium hydroxide
- (d) Mustard oil and calcium hydroxide

27. आपके विद्यालय के पास-पड़ोस में प्रयोग के लिए आवश्यक कठोर जल उपलब्ध नहीं है। आपके विद्यालय में उपलब्ध लवणों के नीचे दिए समूहों में से वह एक समूह चुनिए जिसके प्रत्येक सदस्य को आसुत जल में घोलने पर, वह उसे कठोर जल बना देगा : 1

- (a) सोडियम क्लोराइड, कैल्सियम क्लोराइड
- (b) पोटैशियम क्लोराइड, सोडियम क्लोराइड
- (c) सोडियम क्लोराइड, मैग्नीशियम क्लोराइड
- (d) कैल्सियम क्लोराइड, मैग्नीशियम क्लोराइड

In the neighbourhood of your school, hard water required for an experiment is not available. Select from the following groups of salts available in your school, a group each member of which, if dissolved in distilled water, will make it hard :

- (a) Sodium chloride, calcium chloride
- (b) Potassium chloride, sodium chloride
- (c) Sodium chloride, magnesium chloride
- (d) Calcium chloride, magnesium chloride

28. प्रयोगशाला में मटर के बीज के भ्रूण का प्रेक्षण करते समय किसी छात्र ने नीचे दिए अनुसार 1
भ्रूण के विभिन्न भागों की अपनी नोट बुक में सूची बनाई।

बीजावरण, अन्तःकवच, मूलांकुर, प्रांकुर, बीजाण्ड द्वार, बीजपत्र।

इस सूची का परीक्षण करने के पश्चात शिक्षक महोदय ने यह टिप्पणी की, कि इनमें से केवल तीन भाग ही सही हैं। उपरोक्त सूची में से तीन सही भाग छांटिए :

- (a) बीजावरण, मूलांकुर, बीजपत्र
- (b) अन्तःकवच, मूलांकुर, बीजाण्ड द्वार
- (c) बीजपत्र, प्रांकुर, बीजावरण
- (d) मूलांकुर, बीजपत्र, प्रांकुर

A student while observing an embryo of a pea seed in the laboratory listed various parts of the embryo as given below :

Testa, Tegmen, Radicle, Plumule, Micropyle, Cotyledon.

On examining the list the teacher remarked that only three parts are correct. Select three correct parts from the above list :

- (a) Testa, Radicle, Cotyledon
- (b) Tegmen, Radicle, Micropyle
- (c) Cotyledon, Plumule, Testa
- (d) Radicle, Cotyledon, Plumule

29. यदि आपसे नीचे दी गयी सब्जियों में उन दो सब्जियों के समूह को चुनने के लिए कहा जाए 1
जिनकी संरचनाएँ समजात हैं, तो आप इनमें से किसे चुनेंगे ?

- (a) गाजर और मूली
- (b) आलू और शकरकन्दी
- (c) आलू और टमाटर
- (d) भिण्डी और आलू

If you are asked to select a group of two vegetables, out of the following, having homologous structures which one would you select ?

- (a) Carrot and radish
- (b) Potato and sweet potato
- (c) Potato and tomato
- (d) Lady finger and potato

30. दिए गए अवतल दर्पण की सन्निकट फोकस दूरी ज्ञात करने के लिए आप दर्पण द्वारा किसी दूरस्थ बिम्ब का प्रतिबिम्ब किसी पर्दे पर फोकसित करते हैं। पर्दे पर प्राप्त प्रतिबिम्ब बिम्ब की तुलना में सदैव : 1

- (a) पार्श्व परिवर्तित और छोटा होता है।
- (b) उल्टा और छोटा होता है।
- (c) सीधा और छोटा होता है।
- (d) सीधा और अत्यधिक छोटा होता है।

To determine the approximate value of the focal length of a given concave mirror, you focus the image of a distant object formed by the mirror on a screen. The image obtained on the screen, as compared to the object is always :

- (a) Laterally inverted and diminished
- (b) Inverted and diminished
- (c) Erect and diminished
- (d) Erect and highly diminished

31. मान लीजिए आपने अपनी प्रयोगशाला की मेज के दूरस्थ सिरे पर रखी मोमबत्ती की ज्वाला का प्रतिबिम्ब उत्तल लेंस द्वारा पर्दे पर फोकसित कर लिया है। अब यदि आपके शिक्षक महोदय आपको सूर्य से आपकी मेज पर आती सूर्य की समान्तर किरणों को उसी पर्दे पर फोकसित करने का सुझाव दें, तो आपसे यह अपेक्षा की जाती है कि आप : 1

- (a) लेंस को थोड़ा सा पर्दे की ओर सरकाएंगे।
- (b) लेंस को थोड़ा सा पर्दे से दूर सरकाएंगे।
- (c) लेंस को थोड़ा सा सूर्य की दिशा में सरकाएंगे।
- (d) लेंस और पर्दे दोनों को सूर्य की ओर सरकाएंगे।

Suppose you have focused on a screen the image of candle flame placed at the farthest end of the laboratory table using a convex lens. If your teacher suggests you to focus the parallel rays of the sun, reaching your laboratory table, on the same screen, what you are expected to do is to move the :

- (a) lens slightly towards the screen
- (b) lens slightly away from the screen
- (c) lens slightly towards the sun
- (d) lens and screen both towards the sun

32. आप अपनी प्रयोगशाला में विभिन्न आपतन कोणों ($\angle i$) के लिए कांच के स्लैब से गुजरने वाली प्रकाश किरण का पथ आरेखित करते हैं, तथा प्रत्येक प्रकरण में तदनरूपी अपवर्तन कोण ($\angle r$) और निर्गत कोण ($\angle e$) भी मापते हैं। आपके प्रेक्षणों के आधार आपका सही निष्कर्ष यह है कि :

- (a) $\angle i$ बड़ा है $\angle r$ से, परन्तु $\angle e$ के लगभग बराबर है
- (b) $\angle i$ छोटा है $\angle r$ से, परन्तु $\angle e$ के लगभग बराबर है
- (c) $\angle i$ बड़ा है $\angle e$ से, परन्तु $\angle r$ के लगभग बराबर है
- (d) $\angle i$ छोटा है $\angle e$ से, परन्तु $\angle r$ के लगभग बराबर है

In your laboratory you trace the path of light rays through a glass slab for different values of angle of incidence ($\angle i$) and in each case measure the values of the corresponding angle of refraction ($\angle r$) and angle of emergence ($\angle e$). On the basis of your observations your correct conclusion is :

- (a) $\angle i$ is more than $\angle r$, but nearly equal to $\angle e$
- (b) $\angle i$ is less than $\angle r$, but nearly equal to $\angle e$
- (c) $\angle i$ is more than $\angle e$, but nearly equal to $\angle r$
- (d) $\angle i$ is less than $\angle e$, but nearly equal to $\angle r$

33. नीचे दिए गए आरेख में सही अंकित कोण कौन से हैं ?

1

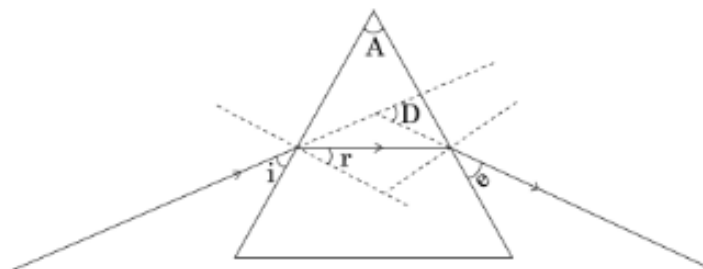

(a) $\angle i$ और $\angle e$

(b) $\angle A$ और $\angle D$

(c) $\angle i$, $\angle e$ और $\angle D$

(d) $\angle r$, $\angle A$ और $\angle D$

In the following ray diagram the correctly marked angle are :

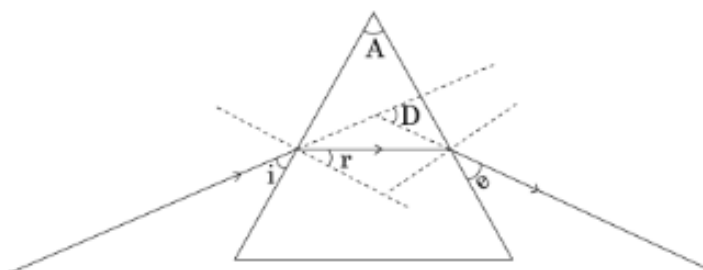

(a) $\angle i$ and $\angle e$

(b) $\angle A$ and $\angle D$

(c) $\angle i$, $\angle e$ and $\angle D$

(d) $\angle r$, $\angle A$ and $\angle D$

34. कोई छात्र एक चम्मच सोडियम हाइड्रोजन कार्बोनेट चूर्ण फ्लास्क में लिए गए एथेनॉइक अम्ल में मिलाता है। उन दो मुख्य प्रेक्षणों की सूची बनाइए, जिन्हें उसे फ्लास्क में होने वाली अभिक्रिया के विषय में अपनी नोट बुक में लिखना चाहिए। होने वाली रासायनिक अभिक्रिया का रासायनिक समीकरण भी लिखिए।

2

A student adds a spoon full of powdered sodium hydrogen carbonate to a flask containing ethanoic acid. List two main observations, he must note in his note book, about the reaction that takes place. Also write chemical equation for the reaction.

35. कोई छात्र यीस्ट में होने वाले अलैंगिक जनन के विभिन्न चरणों को क्रमवार दर्शाने वाली स्थायी स्लाइड का प्रेक्षण कर रहा है। इस प्रक्रिया का नाम लिखिए। जो कुछ वह प्रेक्षण करता है, उसे उचित क्रम में, आरेख खींचकर दर्शाइए। 2

A student is observing a permanent slide showing sequentially the different stages of asexual reproduction taking place in yeast. Name this process and draw diagrams, of what he observes, in a proper sequence.

36. 2.5 cm ऊँचाई का कोई विम्ब 10 cm फोकस दूरी के किसी उत्तल लेंस के प्रकाशिक केन्द्र 'O' से 15 cm दूरी पर स्थित है। बनने वाले प्रतिबिम्ब की स्थिति और साइज ज्ञात करने के लिए किरण आरेख खींचिए। इस आरेख में प्रकाशिक केन्द्र 'O', मुख्य फोकस F तथा प्रतिबिम्ब की ऊँचाई अंकित कीजिए। 2

An object of height 2.5 cm is placed at a distance of 15 cm from the optical centre 'O' of a convex lens of focal length 10 cm. Draw a ray diagram to find the position and size of the image formed. Mark optical centre 'O', principal focus F and height of the image on the diagram.

Strictly Confidential- (For Internal and Restricted Use Only) Secondary School Examination
SUMMATIVE ASSESSMENT - II
March 2016

Marking Scheme – Science (Outside Delhi) 31/1

1. The Marking Scheme provides general guidelines to reduce subjectivity in the marking. It carries only suggested value points for the answer. These are only guidelines and do not constitute the complete answer. Any other individual response with suitable justification should also be accepted even if there is no reference to the text.
2. Evaluation is to be done as per instructions provided in the Marking Scheme. It should not be done according to one's own interpretation or any other consideration. Marking Scheme should be strictly adhered to and religiously followed.
3. If a question has parts, please award marks in the right hand side for each part. Marks awarded for different parts of the question should then be totalled up and written in the left hand margin.
4. If a question does not have any parts, marks be awarded in the left hand side margin.
5. If a candidate has attempted an extra question, marks obtained in the question attempted first should be retained and the other answer should be scored out.
6. Wherever only two/three of a 'given' number of examples/factors/points are expected only the first two/three or expected number should be read. The rest are irrelevant and should not be examined.
7. There should be no effort at 'moderation' of the marks by the evaluating teachers. The actual total marks obtained by the candidate may be of no concern of the evaluators.
8. All the Head Examiners / Examiners are instructed that while evaluating the answer scripts, if the answer is found to be totally incorrect, the (X) should be marked on the incorrect answer and awarded '0' marks.
9. $\frac{1}{2}$ mark may be deducted if a candidate either does not write units or writes wrong units in the final answer of a numerical problem.
10. A full scale of mark 0 to 100 has to be used. Please do not hesitate to award full marks if the answer deserves it.
11. As per orders of the Hon'ble Supreme Court the candidates would now be permitted to obtain photocopy of the Answer Book on request on payment of the prescribed fee. All Examiners/Head Examiners are once again reminded that they must ensure that evaluation is carried out strictly as per value points given in the marking scheme.

**MARKING SCHEME
CLASS X – OUTSIDE DELHI**

Code No. 31/1

	Expected Answer/ Value point	Marks	Total
SECTION – A			
Q1.	Propanol, <div style="display: flex; align-items: center; justify-content: center; margin-top: 5px;"> <div style="border: 1px solid black; padding: 5px; margin-right: 10px;"> $\begin{array}{cccc} & \text{H} & \text{H} & \text{H} \\ & & & \\ \text{H} & - \text{C} & - \text{C} & - \text{C} - \text{OH} \\ & & & \\ & \text{H} & \text{H} & \text{H} \end{array}$ </div> <div>OR $\text{CH}_3\text{-CH}_2\text{-CH}_2\text{-OH}$</div> </div>	½, ½	1
Q2.	Its filament breaks up into smaller fragments or pieces, and each fragment grows into a new filament/individual.	½, ½	1
Q3.	Ultraviolet rays from the sun penetrate down the earth and cause health hazards/skin cancer in human beings	1	1
Q4.	<ul style="list-style-type: none"> • Concave Mirrors / Converging Mirrors • When a solar furnace is placed at the focus of a large concave mirror/ reflector, it focuses a parallel beam of light on the furnace, consequently a high temperature is achieved after some time. 	½ 3 x ½	 2
Q5.	<ul style="list-style-type: none"> • Chipko Andolan (Hug the Trees Movement) – Women of Reni village in Garhwal hugged the tree trunks preventing the contractors from felling the trees. • This Andolan quickly spread to other parts of the country and forced the government to rethink their priorities in the use of forest produce, consequently the local people benefitted. • The environment was saved from permanent damage/ affected the quality of soil and the sources of water. 	1 ½, ½	 2
Q6.	Burning of fossil fuels produces green house gases(CO , CO_2 , water vapour, oxides of nitrogen, sulphur). High concentration of CO_2 causes global warming.	1, 1	2
Q7.	$2\text{CH}_3\text{COOH} + 2\text{Na} \rightarrow 2\text{CH}_3\text{COONa} + \text{H}_2$		
a)	\rightarrow Sodium ethanoate/ Sodium acetate	½, ½	
b)	$\text{CH}_3\text{COOH} + \text{NaOH} \xrightarrow{\hspace{2cm}} \text{CH}_3\text{COONa} + \text{H}_2\text{O}$ Sodium ethanoate/ sodium acetate	½, ½	
c)	$\text{CH}_3\text{COOH} + \text{C}_2\text{H}_5\text{OH} \xrightarrow{\hspace{2cm}} \text{CH}_3\text{COOC}_2\text{H}_5 + \text{H}_2\text{O}$ Ethyl ethanoate/ ester	½, ½	3

Q8. • Propanal (aldehyde) ; ½, ½

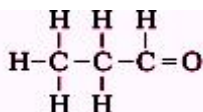

• Propanone(ketone); ½, ½

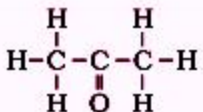

• Isomers(same molecular formula but different structural formula/different functional group) 1 3

Q9. • Electronic Configuration of X – 2,8,6
 Valence electrons – 6
 Valency = 8-6= 2 ½, ½
 • Formula with hydrogen- H₂X or H₂S

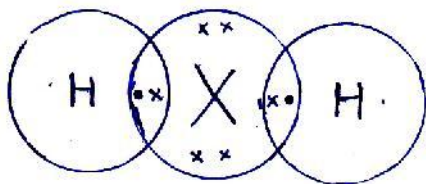

Sulphur ; NonMetal ½, ½ 3

Q10. Atomic number of X = Mass number of X – No of neutrons ½

$$= 35 - 18 = 17 \quad \text{½}$$

Therefore Electronic configuration of X = 2,8,7 ½

Group number =17 ½

Period no = 3

Valency = 8-7 = 1 ½, ½ 3

Q11. Reproduction – It is a (biological) process by which new individuals of the same species are produced by the existing organisms 1

• Populations of organisms live in well defined places called niches in the ecosystem using their ability to reproduce. ½

• Reproduction involves DNA copying which is the source of information for making proteins thereby controlling body design ½

• These body designs allow the organism to use a particular niche for the stability of the population of a species ½

• (Minor) variations may also lead to the stability of the species ½ 3

Q12. Regeneration- It is the ability of an organism to give rise to a new organism/ individual from their body parts 1

Regeneration in hydra-			
	• When the body of hydra by any means is cut into number of pieces	1/2	
	• Each piece contains specialized cells	1/2	
	• These cells proliferate and make large number of cells	1/2	
	• From this mass of cells different cells undergo changes to become various cell types and tissues finally developing into a new organism	1/2	3
Q13.	a) i) Involvement of two different individuals		
	ii) Creation of new combination of variants	1/2, 1/2	
	b) i) pollen/pollen grain		
	ii) by pollination/ agents of pollination		
	iii) It (pollen tube) helps male gamete to reach egg (ovule)		
	iv) Converts into embryo	4 x 1/2	3
Q14.	• When a cross was made between a tall pea plant with round seeds and a short pea plant with wrinkled seeds, the F1 progeny plants are all tall with round seeds: this indicates that tallness and round seeds are the dominant traits.	1	
	• When the F1 plants are self pollinated the F2 progeny consisted of some tall plants with round seeds and some short plants with wrinkled seeds which are the parental traits	1	
	• There were also some new combinations like tall plants with wrinkled seeds and short plants with round seeds	1/2	
	• Thus it may be concluded that tall and short traits and round and wrinkled seed traits have been inherited independently	1/2	3
	OR		
	A flow chart depicting the same		
	Note: Any other contrasting characters can also be taken		
Q15.	• Different forms of organisms/ life have evolved during the course of evolution, and classification deals with grouping of these organisms into groups and subgroups based on their similarities and differences.	1/2, 1/2	
	• The more characteristics any two species have in common more closely they are related/ will have a more recent ancestor(and vice versa)	1	
	• Thus classification helps tracing the evolutionary relationships between the two organisms hence classification and evolution are interlinked.	1	3
Q16.	Object position: At C (Centre of curvature)	1/2	
	Object distance = 40 cm	1/2	
	Position of the image - at infinity	1/2	
	Reason – Focal length of the mirror = 20 cm		
	If the object is moved 20 cm towards the mirror then its new position would be at the focus of the mirror.	1/2	

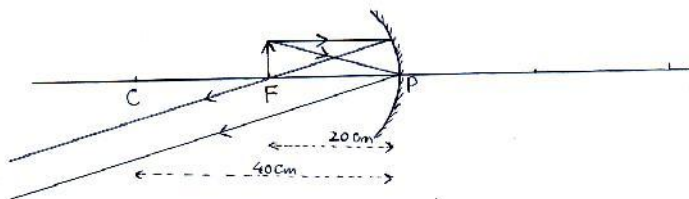

(deduct ½ mark if arrows are missing/ not marked) 1 3

Q17. Description of activity- When a glass prism is used to obtain a spectrum of sunlight, a second identical prism in an inverted position with respect to the first position will allow all the colours of spectrum to recombine .Thus a beam of white light will emerge from the other side of the second prism. 1 ½

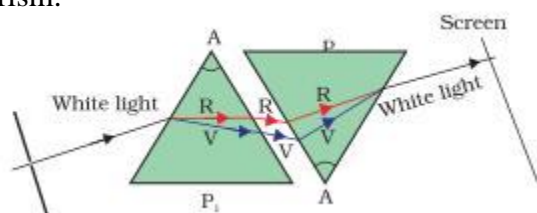

1 ½ 3

Q18 Two reasons for the conservation of the environment:

- (a) 1) To save air, water and soil from pollution
2) To maintain ecological balance in nature 2 x ½
- (b) Green dustbins- for biodegradable waste, and blue dustbins for non biodegradable waste for proper disposal of waste without wasting time and energy in segregating the biodegradable and non - biodegradable wastes 2 x ½
- (c) Values – cooperative spirit, concern about environment, civic sense
Or any other (Any two) 2 x ½ 3

Q19. P= Ethanol/C₂H₅OH Q= Ethene/CH₂=CH₂ R=Ethane/ C₂H₆ 3x ½

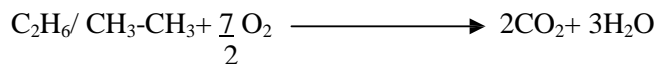
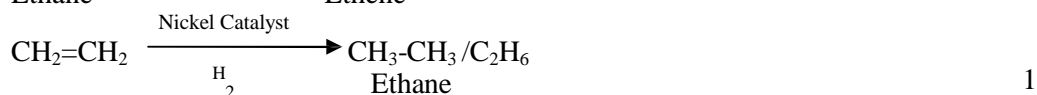
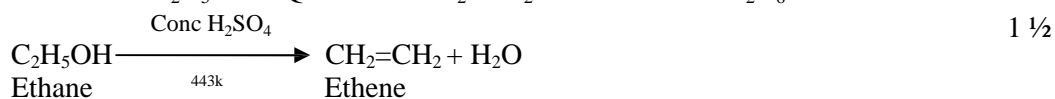

Note: Correct equation even without balancing be given full credit 1 5

Q20. Placenta- A special tissue that helps human embryo in obtaining nutrition from mother's blood 1
Structure- this is a disc which is embedded in the uterine wall which 1,1

contains villi on the embryo side of the tissue, and on the mother's side are blood spaces which surround the villi

Function- This provides a large surface area for glucose and oxygen to pass from the mother to the embryo, and the developing embryo will also generate waste substances which can be removed by transferring them into the mothers blood through the placenta

1, 1 5

- Q21. Evolution- The gradual unfolding of organisms from pre-existing organisms through change since the origin of life
It occurs because there is an inbuilt tendency to variation during reproduction due to errors in DNA copying and as a result of sexual reproduction.

1

1,1

It is observed that although fossils appeared different from the existing species they may show certain features similar to the existing species thus providing linkages between pre-existing and existing forms

1

Provide information about the extinct species which were different from the existing species.

1 5

- Q22. (i) Range of distance – between 0 cm - < 12 cm
ii) larger than the object

1

½

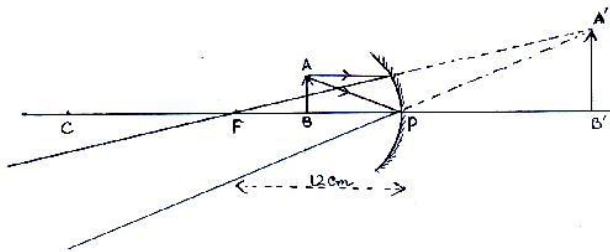

1 ½

- iii) Image also at 24 cm in front of the mirror

½

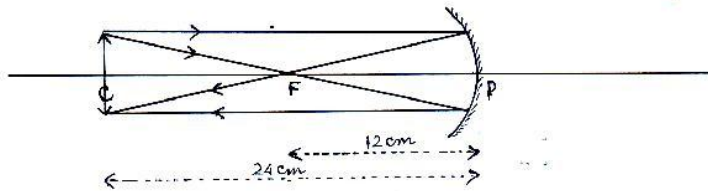

1 ½ 5

- Q23. a) Optical centre- the central point of a lens.

1

- b) $f = -20$ cm

½

$h_1 = 4$ cm $v = -10$ $u = ?$ $h_2 = ?$

$$\frac{1}{f} = \frac{1}{v} - \frac{1}{u}$$

½

$$= \frac{-1}{-10} - \frac{1}{-20} = \frac{-1}{10} + \frac{1}{20}$$

$$= \frac{-2+1}{20} = \frac{-1}{20}$$

$u = -20$ cm

1

$$h_i = \frac{v}{u} h_o$$

$$= \frac{-10 \text{ cm}}{-20 \text{ cm}} \times 4 = 2 \text{ cm}$$

1/2
1/2

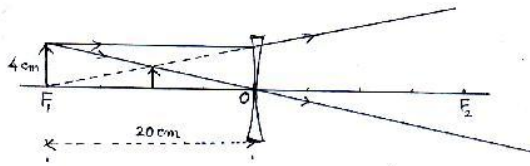

1 5

Q24 Atmospheric refraction- refraction of light caused by the earth's atmosphere due to change in the refractive indices of different layers
Twinkling of stars- stars are distant point sized source of light. The path of the rays of light coming from the star goes on varying due to atmospheric refraction slightly. Thus apparent position of the stars fluctuates and the amount of star light entering the eye flickers giving the twinkling effect

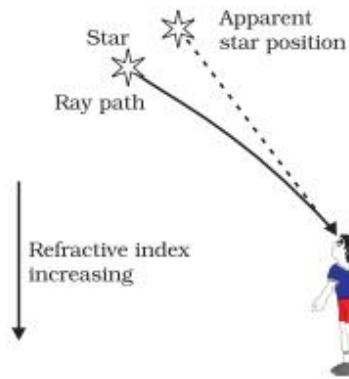

1

Advanced sunrise – when the sun is slightly below the horizon, light rays coming from the sun travel from the rarer to denser layers of air. Because of atmospheric refraction of light, light appears to come from a higher position above the horizon. Thus sun appears earlier than actual sunrise.
Delayed sunset- Same reason as similar refraction occurs at the sunset.

1

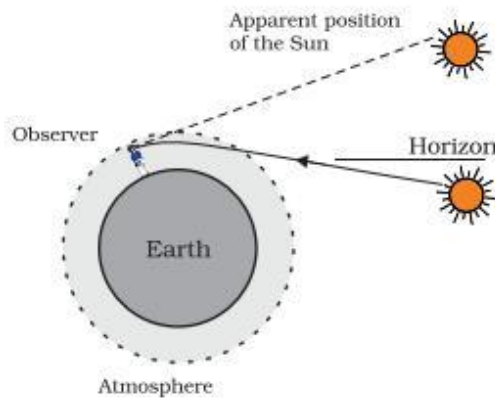

1 5

SECTION – B

- | | | |
|--------|--------|--------|
| 25 (c) | 26 (c) | 27 (d) |
| 28 (d) | 29 (a) | 30 (b) |
| 31 (a) | 32 (a) | 33 (d) |

1 x 9 9

Q34. Brisk effervescence

½

Evolution of colourless /odourless gas

½



1 2

Q35. • Budding

½

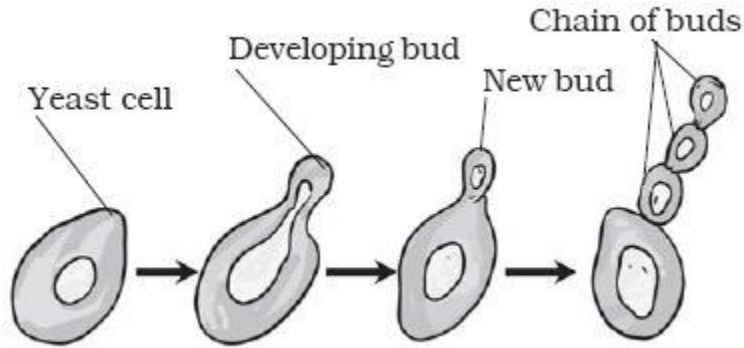

(Three/ four diagrams in proper sequence)

1 ½ 2

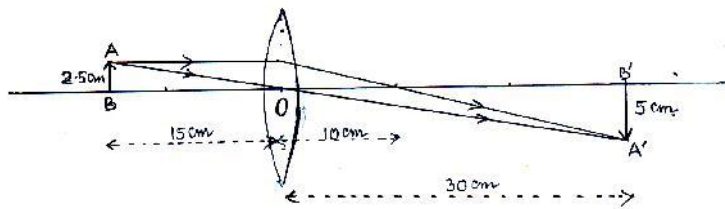

Q36. Marking of O, F and size of the image

1
1 2

HUMAN HEART

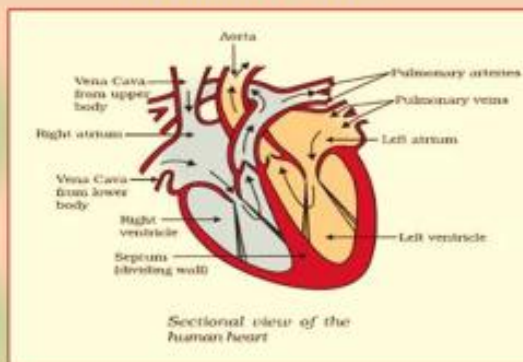

HUMAN EYE

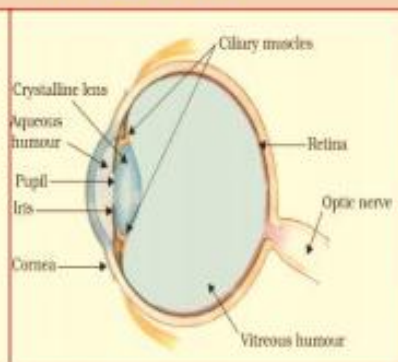

NATURE, IMAGE AND ITS FORMATION (CONVEX LENS)

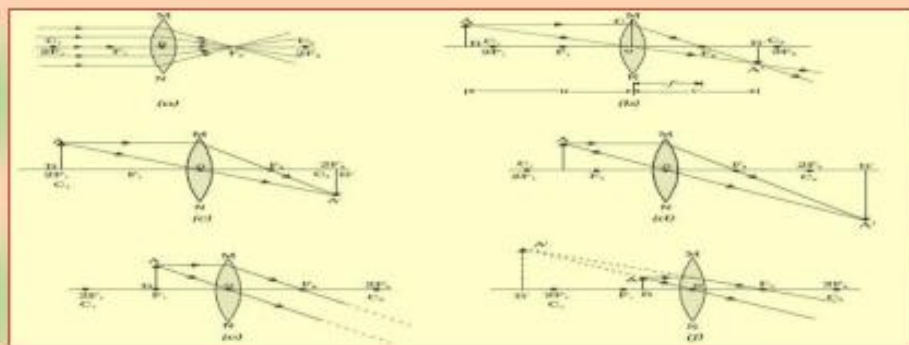

FORMATION OF NaCl

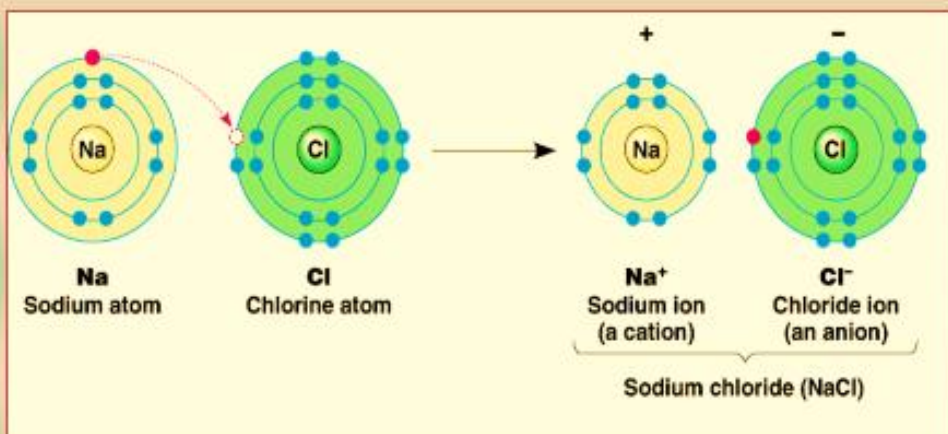

EXAMINATION TIPS

1. Set your goals. **WRITE YOUR TARGET FOR EACH SUBJECT**
2. Prepare a **study time table** of your own and **adhere to it strictly**.
3. If you are not performing up to your level in a particular subject, **do not postpone studying** for this subject at all.
4. Your plan has to **be realistic**. Do not stuff too many things in a day. Set aside some time in the day for relaxation like playing/ watching television/ listening to music.
5. **Avoid watching too much of television/ accessing internet/using mobiles during exams.**
6. **Practice by Writing**
Practice makes a man perfect. Hence practice writing in all the subjects to score better.
7. **Timing of Studying** - Choose your study timings.
8. **Drawing in Science**
Good drawings fetch you good marks. Practice drawings.
9. **Health is Wealth**
Take care of your health. Eat plenty of fruits and vegetables during your exams and drink plenty of water too.
10. **Revision – a Must**
Revising your lessons will clarify your doubts and boost your confidence.
11. **Prayer/Meditation**
Do devote at least 10 minutes for prayer/meditation as it helps in improving your confidence and concentration.
12. **Go for short Walks**
Take a short walk in the evenings to rejuvenate yourself.
13. **On the Exam Day**
 - * Do not cram till the last minute.
 - * Be ready to go to school well in advance.
 - * Check your compass box, pens, pencils, sharpeners, erasers, scales etc.
 - * 30 minutes prior to the commencement of the exam, close all your books and relax.
 - * While answering the questions, read the questions carefully and attempt the questions that you know first.
 - * Attempt all the questions.

PROMOTION POLICY FOR CLASS IX & X

It is mandatory for students to appear in both the Summative Assessments (SA1 and SA2) and score a minimum of 25% marks in the aggregate of these assessments along with 33% overall marks for qualifying to the next higher class

