

KF Valves

Series F/FE

Flanged Floating Ball Valves



KF Series F/FE Unibody & Two-Piece Floating Ball Valves

Features

- Anti-blowout stem design
- Weather seal (class 600 & higher)
- Actuator mounting pad (4 bolt machined)
- Secondary metal-to-metal sealing
- Full rated bi-directional dead end service
- Antistatic device
- Lockable handle
- O-Ring design (standard)
- Graphite or teflon® packing (optional for series F class 150 and 300 model G XXXX only)

KF flanged floating ball valves are a prime example of KF's reliability, performance, manufacturing and superior

engineering techniques at work- featuring a unibody or two-piece bolted design.



Contents

Valve Assembly Part Number Codes	3
Design Features	4
Applicable Standards	5
Series F Component Parts, Class 150 & 300, Model G XXXX	6
Series FE Component Parts, Class 150 & 300, Model E XXXX	7
Series F/FE Component Parts, Class 600, 900 & 1500, Model G XXXX & E XXXX	8
Series F Unibody Dimensional Data, Class 150 & 300, Model G XXXX	9
Series F Split Body Dimensional Data, Class 150 & 300, Model G XXXX	10-11
Series F/FE Split Body Dimensional Data, Class 600, 900 & 1500, Model G XXXX & E XXXX	12
Engineering Data	13
Series F Topworks & Stem Dimensions, Model G XXXX	14
Series FE Topworks & Stem Dimensions, Model E XXXX	15

KF Series F/FE Part Number Codes

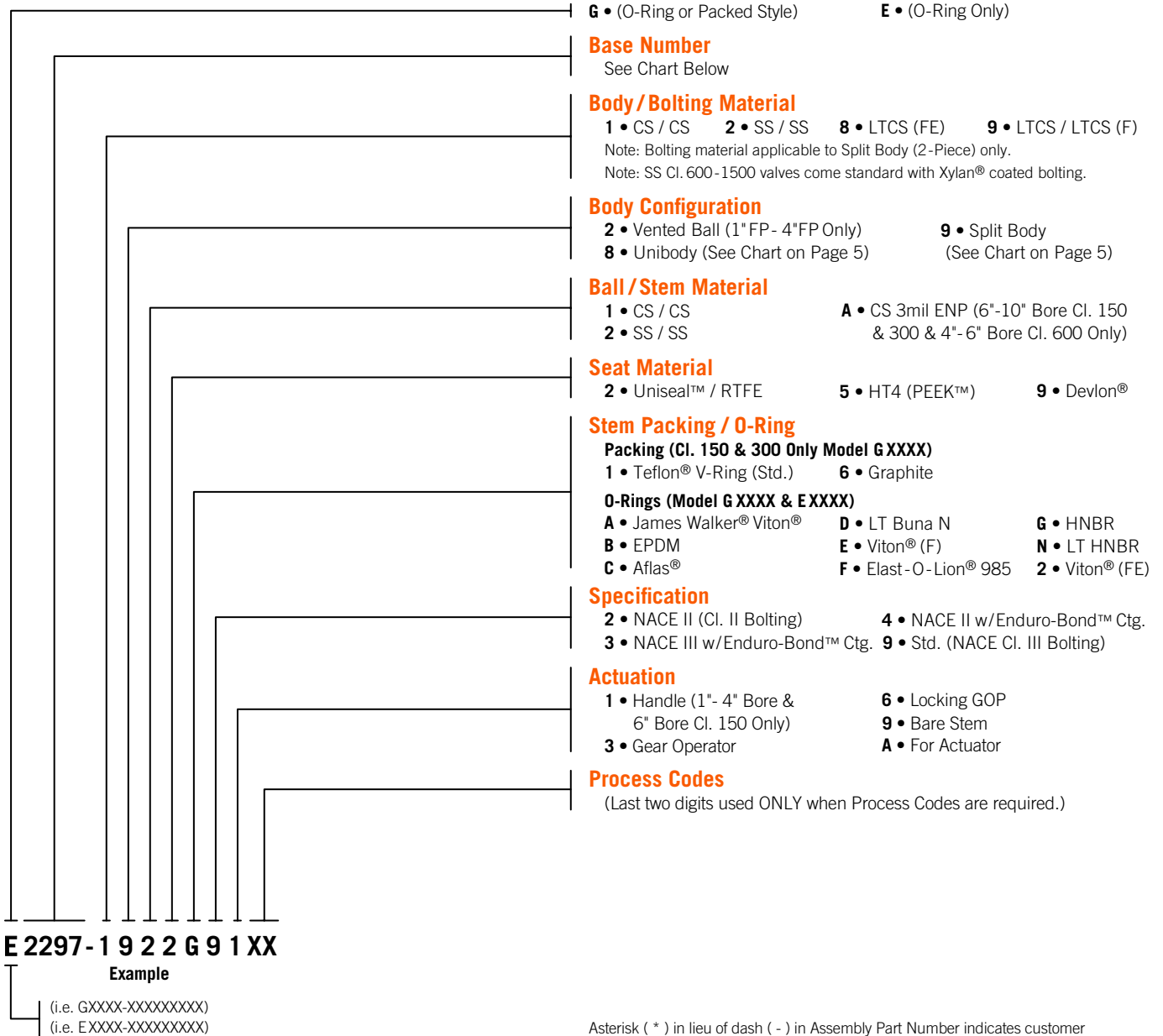

Asterisk (*) in lieu of dash (-) in Assembly Part Number indicates customer requires source inspection. (i.e. XXXXX * XXXXXXXXX)

Assembly Base Numbers, 1"FP- 8"FP

Class/End Connection	Size (in.)												
	1 FP	1 1/2 FP	2 RP	2 FP	2 1/2 RP	3 RP	3 FP	4 RP	4 FP	6 RP	6 FP	8 RP	8 FP
150 RF	2147	2149	2150	2151	2152	2153	2154	2155	2156	2157	1720	1721	1722
300 RF	2297	2299	2300	2301	2302	2303	2304	2305	2306	2307	1724	1725	1726
600 RF	2597	2599	2600	2601	2602	2603	2604	2605	2606	2618	—	—	—
600 RTJ	2607	2609	2610	2611	2612	2613	2614	2615	2616	2617	—	—	—
900 RF	3348*	—	2900*	2901*	—	—	—	—	—	—	—	—	—
900 RTJ	3349*	—	2910*	2911*	—	—	—	—	—	—	—	—	—
1500 RF	3348*	—	—	—	—	—	—	—	—	—	—	—	—
1500 RTJ	3349*	—	—	—	—	—	—	—	—	—	—	—	—

*Series F only

KF Series F/FE Design Features

1 Blowout Proof Stem

Internally inserted, “backseated” stem assures fire safety and blow-out prevention by retaining stem in the valve at all pressures.

2 Stem Journal Lubrication

All valves incorporate external stem lubrication. A vented weather seal allows safe pressure relief in event of excessive grease gun pressure.

3 Antistatic Device

A conductive spring and a graphite washer provide antistatic continuity throughout the valve.

4 Antistatic Device

1" - 4" Bore, cl. 600, 900 & 1500 use spring-loaded pins between the ball, stem and body to provide antistatic continuity throughout the valve.

5 Firesafe Seat Sealing

In event of fire and seat destruction, ball floats downstream to effectively provide metal-to-metal seat sealing.

6 Positive Low & High Pressure Sealing for Devlon® and HT4 Seats

A special integral seat lip provides positive low pressure “bubble-tight” sealing between the ball and seat with minimal operating torque. The KF seat lip defects slightly at higher pressures to ensure full seat contact with the ball. The seat’s “memory-action” provides “bubble-tight” sealing at both low and high pressures. This “self compensation for swell” feature results in low torque and long life operation.

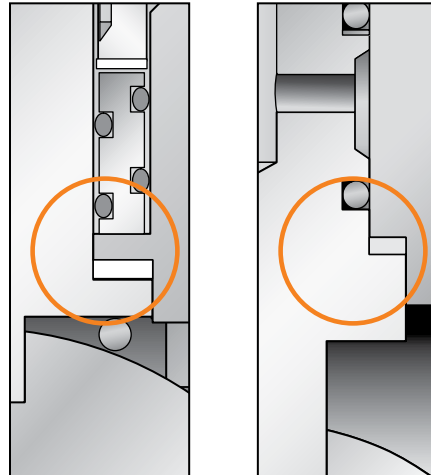

1 Cl. 150 & 300 (F)

Cl. 600 & Higher (F)
Cl. 150 & 300 (FE)

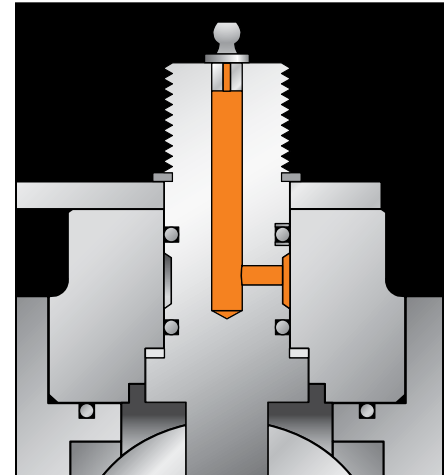

2 Cl. 600 & Higher (F & FE)

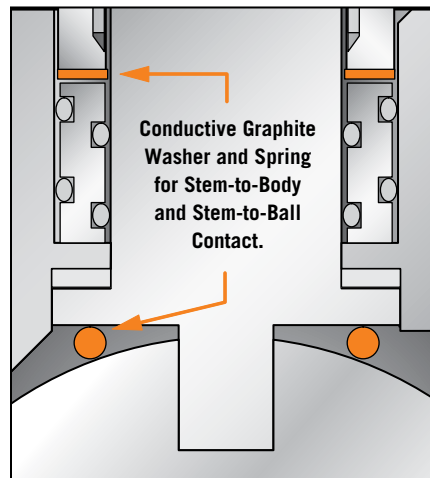

3 Cl. 150 & 300 O-Ring shown,
packing also available. (F)

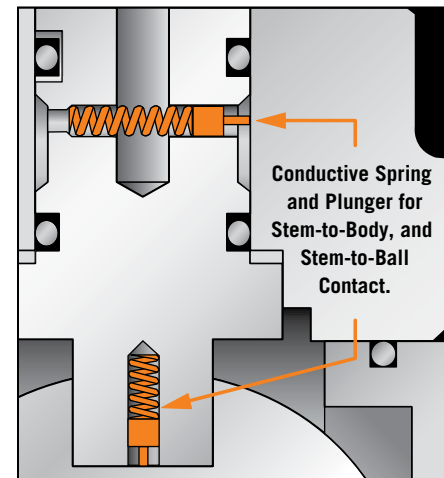

4 Cl. 600 & Higher (F & FE)

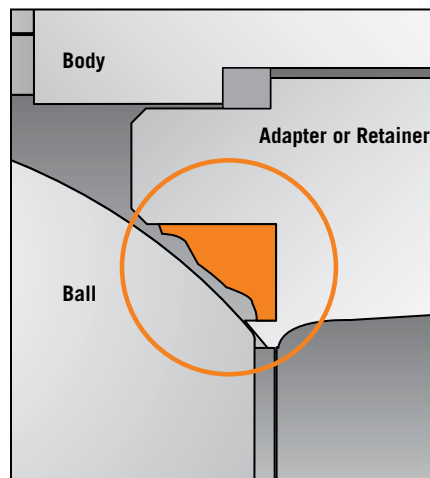

5

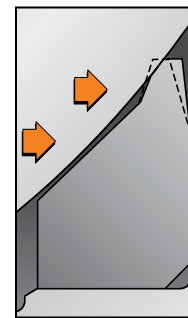

6 Low Pressure
Sealing

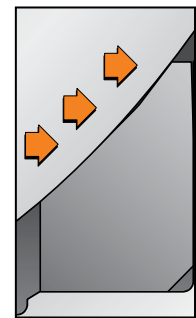

High Pressure
Sealing

KF Series F/FE Applicable Standards

The following list contains the most important applicable standards for ball valves. KF valves may be designed, manufactured and tested in accordance with other international standards on request.

API- American Petroleum Institute

Spec. 6D

Specification for pipeline valves.

Std. 598

Valve inspection and test.

Std. 607

Fire test for soft seated quarter-turn valves.

Std. Q1

Specification for quality management system requirements.

ASME/ANSI- American National Standard Institute

B 16.5

Steel pipe flanges and flanged fittings.

B 16.10

Face-to-face and end-to-end dimensions of ferrous valves.

B 16.34/ BPVC Sec. VIII

Steel valves- flanged end.

B 31.3

Chemical plant and petroleum refinery piping.

B 31.4

Liquid petroleum transportation piping systems.

B 31.8

Gas transmission and distribution piping systems.

EC- European Community

CE Marked

P.O.A. consult factory.

ISO-International Organization for Standardization

ISO 9001

Quality systems- Model for quality assurance in design/development, production, installation and servicing.

ISO 15156

Materials for use in H₂S containing environments in oil and gas production.

MSS- Manufacturers Standardization Society

SP 6

Standard finishes for contact faces of pipe flanges and connecting- end flanges of valves and fittings.

SP 25

Standard marking system for valves, fittings, flanges and unions.

SP 55

Quality standard for steel castings- visual method.

Hydrogen Sulfide (H₂S Environments)

NACE MR0175/ ISO 15156

General principles for cracking resistant materials in H₂S containing environments in oil & gas production.

CSA-

Canadian Standards Association

CSA Z245.15

Standard for steel valves for intended use in oil or gas pipeline systems.

CSA Z245.12

Standard for steel flanges intended to be used for transporting fluids.

CSA Z662

Oil and gas pipeline systems.



Size Range & Design Availability

Class	Size (in.)												
	1 FP	1 1/2 FP	2 RP	2 FP	2 1/2 RP	3 RP	3 FP	4 RP	4 FP	6 RP	6 FP	8 RP	8 FP
150	▲●	▲●	■●	▲●	▲●	■●	▲●	■●	▲●	■●	▲●	▲●	▲●
300	▲●	▲●	■●	▲●	▲●	■●	▲●	■●	▲●	■●	▲●	▲●	▲●
600	▲●	▲●	▲●	▲●	▲●	▲●	▲●	▲●	▲●	▲●	▲●	▲●	—
900	▲	—	▲	▲	—	—	—	—	—	—	—	—	—
1500	▲	—	—	—	—	—	—	—	—	—	—	—	—

■ Unibody ▲ Split Body ● FE Split Body

KF Series F Component Parts, Class 150 & 300 (Model GXXXX)

Unibody Configuration (Reduced Bore Only)

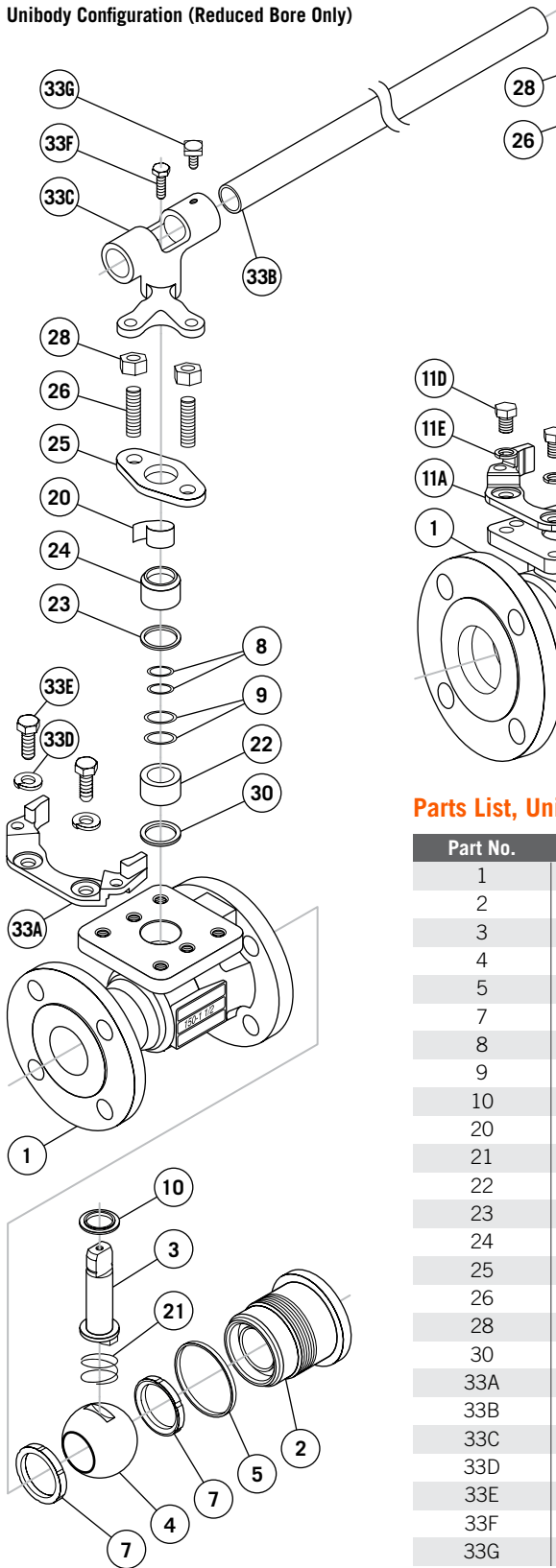

Split Body Configuration (Full Port Only)

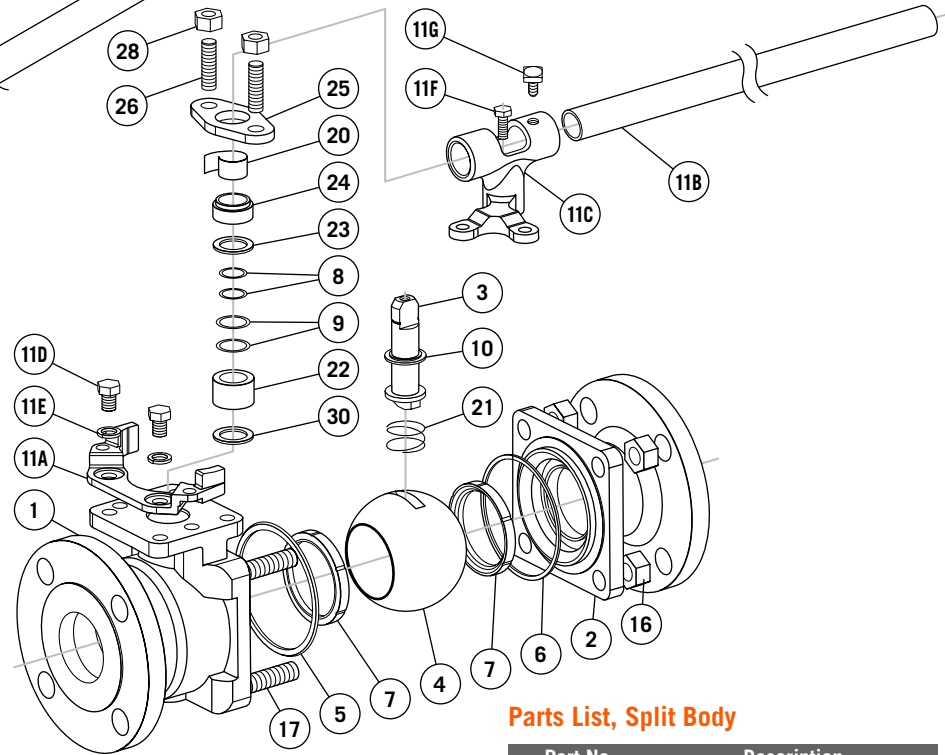

Parts List, Unibody

Part No.	Description
1	Body
2	Seat Retainer
3	Stem
4	Ball
5	Body Seal
7	Seat
8	Inner Stem O-Rings***
9	Outer Stem O-Rings***
10	Thrust Washer
20	Liner
21	Ground Spring
22	Stem Seal, Gland or Packing
23	Ground Washer*
24	Follower
25	Retainer
26	Follower Stud
28	Follower Nut
30	Stem Washer**
33A	Lock Plate
33B	T-Handle Tube
33C	T-Handle Hub
33D	Lock Washer
33E	Hex Screw
33F	Hex Screw
33G	Square Screw

Parts List, Split Body

Part No.	Description
1	Body
2	Adapter
3	Stem
4	Ball
5	Body Gasket
6	Body O-Ring***
7	Seat
8	Inner Stem O-Rings***
9	Outer Stem O-Rings***
10	Thrust Bearing
11A	Lock Plate
11B	T-Handle Tube
11C	T-Handle Hub
11D	Lock Plate Screw
11E	Lock Plate Lock Washer
11F	Handle Hub Screw
11G	Tube Lock Screw
16	Hex Nut
17	Stud
20	Follower Liner
21	Ground Spring
22	Stem Seal, Gland or Packing
23	Ground Washer*
24	Packing Follower
25	Packing Retainer
26	Packing Stud
28	Packing Nut
30	Stem Washer**

* Not required with Grafoil® packing in Firesafe valves.

** Required in 2" and larger packed valves only.

*** Not used in packed stem valves.

KF Series FE Component Parts, Class 150 & 300 (Model E XXXX)

1"FP thru 8"FP Class 150 & 300

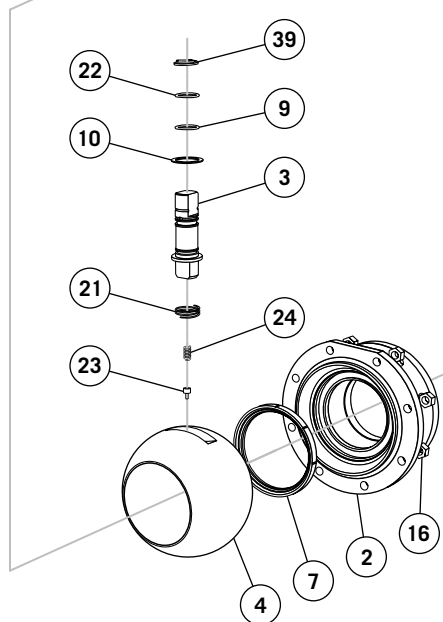
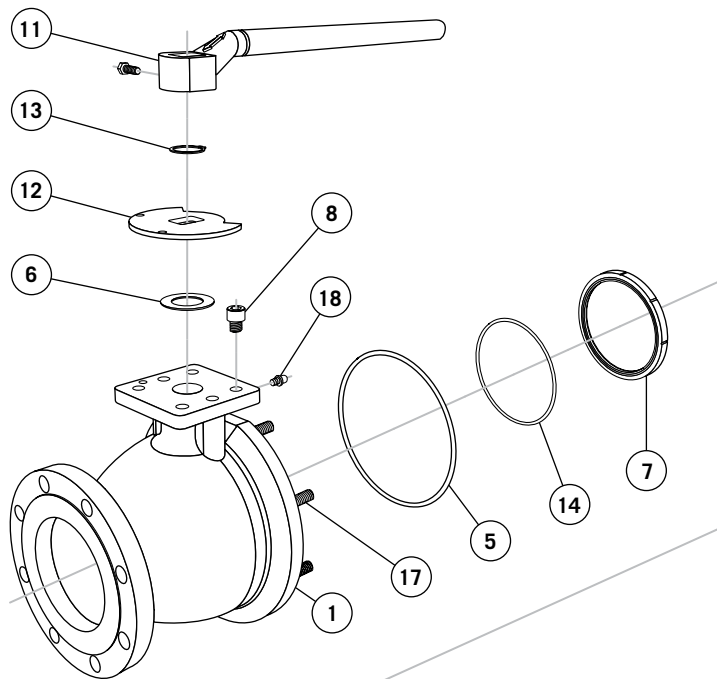

Parts List

Part No.	Description
1	Body
2	Adapter
3	Stem
4	Ball
5	Body Seal
6	Stem Bearing*
7	Seat
8	Stop Screw*
9	Stem Seal
10	Thrust Bearing
11	Handle Assembly*
12	Stop Plate*
13	Retainer*
14	Adapter Pilot Seal
16	Hex Nut
17	Stud
18	Lube Fitting
21	Ground Spring**
22	Firesafe Stem Packing
23	Ground Plunger*
24	Ground Spring*
39	Weather Seal

*4" Bore Only

**6" Bore Only

KF Series F/FE Component Parts, Class 600, 900 & 1500 (Model GXXXX/EXXXX)

1"FP thru 4"RP
Class 600, 900 & 1500

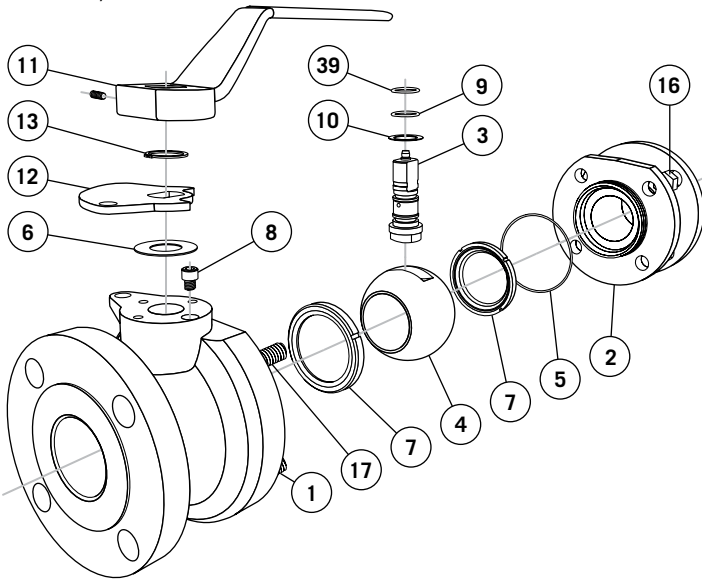

Parts List, Class 600, 900 & 1500

Part No.	Description
1	Body
2	Adapter
3	Stem
4	Ball
5	Body Seal
6	Stem Bearing
7	Seat
8	Stop Screw
9	Stem Seal
10	Thrust Bearing
11	Handle Assembly
12	Stop Plate
13	Retainer
16	Hex Nut
17	Stud
39	Weather Seal

4"FP thru 6"RP Class 600

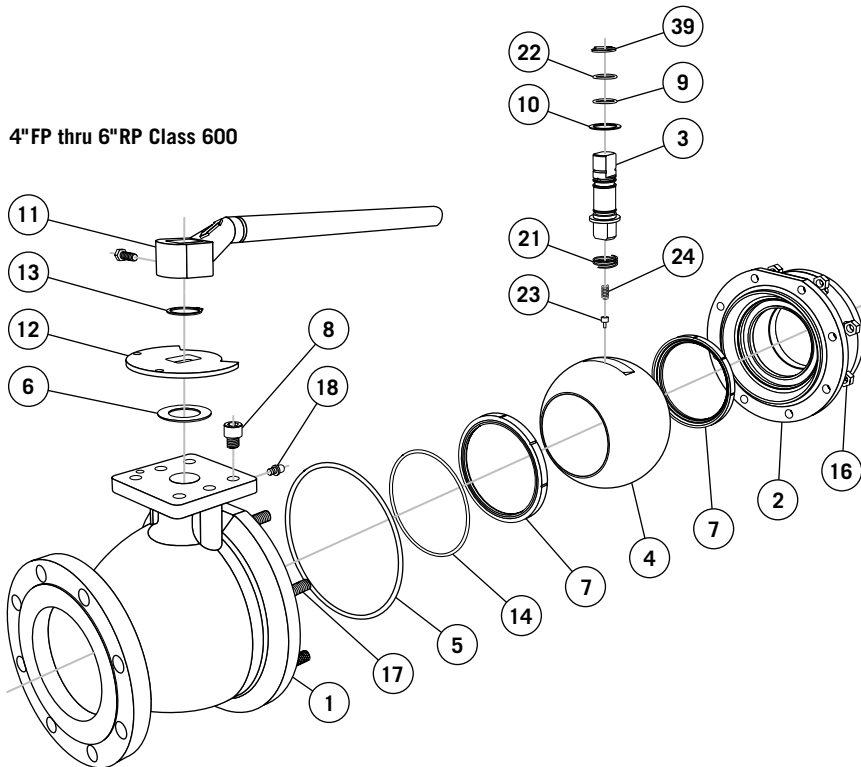

Parts List, Class 600

Part No.	Description
1	Body
2	Adapter
3	Stem
4	Ball
5	Body Seal
6	Stem Bearing*
7	Seat
8	Stop Screw*
9	Stem Seal
10	Thrust Bearing
11	Handle Assembly*
12	Stop Plate*
13	Retainer*
14	Adapter Pilot Seal
16	Hex Nut
17	Stud
18	Lube Fitting
21	Ground Spring**
22	Firesafe Stem Packing
23	Ground Plunger*
24	Ground Spring*
39	Weather Seal

*4" Bore Only

**6" Bore Only

KF Series F Unibody Dimensional Data (Model G XXXX)

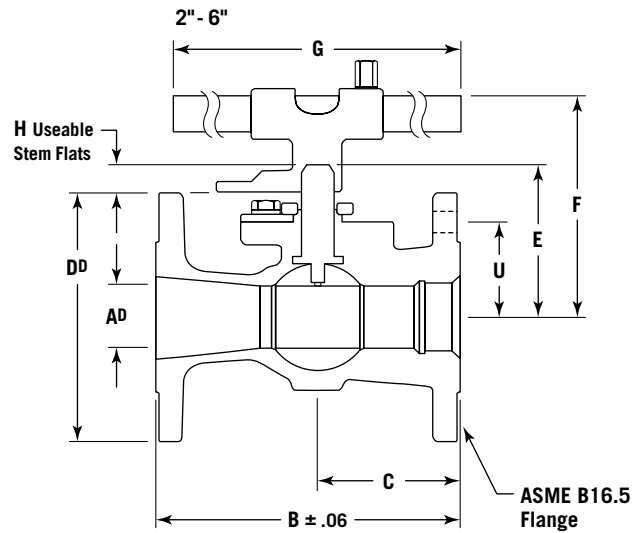

Dimensional Data (in., mm), 2"-6", Class 150, Reduced Port

Size (in.)	Dimension (in.)									Weight (lbs.)
	A	B	C	D	E	F	G	H	U	
2	1.50	7.00	3.27	6.00	3.69	5.36	17.00	.70	2.31	17.6
3	2.42	8.00	3.46	7.50	4.38	6.05	17.00	.70	3.06	31.5
4	3.00	9.00	4.10	9.00	6.75	8.83	22.00	1.38	4.43	54.2
6	4.50	10.50	5.25	11.00	8.56	10.55	22.00	1.44	6.02	137.0
	Dimension (mm)									(kg)
2	38.1	177.8	83.1	150.9	93.7	136.1	431.8	17.8	58.7	7.98
3	61.5	203.2	87.9	189.0	111.3	153.7	431.8	17.8	77.7	14.29
4	76.2	228.6	104.1	227.1	171.5	224.3	558.8	35.1	112.5	24.58
6	114.3	266.7	133.4	279.4	217.4	268.0	558.8	36.6	152.9	62.14

Dimensional Data (in., mm), 2"-6", Class 300, Reduced Port

Size (in.)	Dimension (in.)									Weight (lbs.)
	A	B	C	D	E	F	G	H	U	
2	1.50	8.50	3.27	6.50	3.69	5.36	17.00	.70	2.31	26.0
3	2.42	11.12	3.96	8.25	4.38	6.05	17.00	.70	3.06	46.0
4	3.00	12.00	4.10	10.00	6.75	8.83	22.00	1.38	4.43	70.0
6	4.50	15.88	5.25	12.50	8.56	10.55	22.00	1.44	6.02	157.0
	Dimension (mm)									(kg)
2	38.1	215.9	83.1	165.1	93.7	136.1	431.8	17.8	58.7	11.79
3	61.5	282.4	100.6	209.6	111.3	153.7	431.8	17.8	77.7	20.87
4	76.2	304.8	104.1	254	171.5	224.3	558.8	35.1	112.5	31.75
6	114.3	403.4	133.4	317.5	217.4	268.0	558.8	36.6	152.9	71.21

KF Series F Split Body Dimensional Data (Model G XXXX)

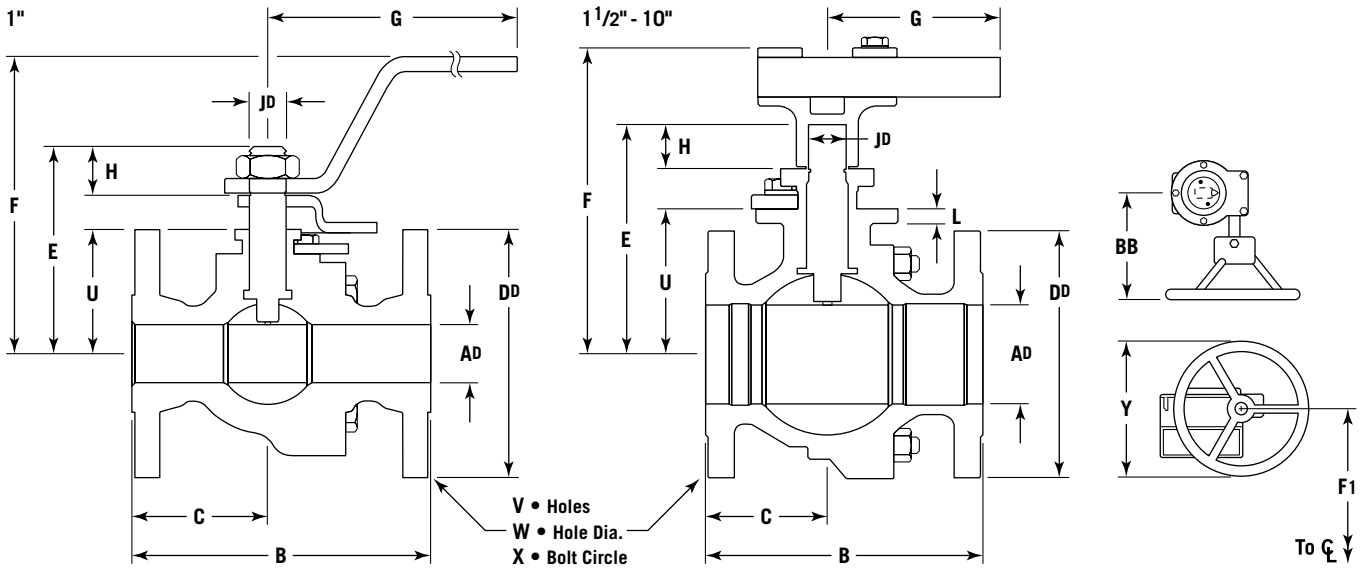

Dimensional Data (in.), 1"-8", Class 150

Size (in.)	Dimension (in.)																Wt. (lbs.)	
	A	B	C	D	E	F	F ₁	G	H	J	L	U	V	W	X	Y		BB
1 x 1	1.00	5.00	2.31	4.25	3.50	5.44	—	6.31	1.32	.586	—	1.69	4	.63	3.13	—	—	17.0
1 1/2 x 1 1/2	1.50	6.50	2.96	5.00	3.69	5.75	7.37	15.50	.640	.705	.38	2.31	4	.63	3.88	6.00	6.50	12.8
2 x 2	2.00	7.00	3.02	6.00	4.51	6.56	8.20	15.50	.640	.705	.44	3.14	4	.75	4.75	6.00	6.50	17.6
2 1/2 x 2*	2.00	7.50	2.94	7.00	4.38	6.06	—	8.50	1.00	.873/.871	—	3.06	4	.75	5.50	—	—	37.5
3 x 3	3.00	8.00	3.50	7.50	6.81	10.25	11.63	20.00	1.28	1.067/1.062	.44	4.43	4	.75	6.00	6.00	6.50	31.5
4 x 4	4.00	9.00	4.00	9.00	8.40	11.00	13.08	20.00	1.28	1.321/1.316	.62	5.88	8	.75	7.50	8.00	9.00	54.2
6 x 6	6.00	15.50	7.75	11.00	10.81	11.12	15.63	20.00	1.45	1.515/1.510	.75	8.00	8	.88	9.50	8.00	9.50	137
8 x 6	6.00	11.50	5.13	13.50	10.81	11.12	15.63	20.00	1.45	1.515/1.510	.75	8.00	8	.88	9.50	8.00	9.50	210
8 x 8	8.00	18.00	9.00	13.50	14.25	—	18.26	—	2.27	1.997/1.994	.62	9.64	8	.88	9.50	12.00	9.50	477

Dimensional Data (in.), 1"-8" Class, 300

Size (in.)	Dimension (in.)																Wt. (lbs.)	
	A	B	C	D	E	F	F ₁	G	H	J	L	U	V	W	X	Y		BB
1 x 1	1.00	6.50	3.50	4.88	3.50	5.44	—	6.31	1.32	.586	—	1.69	4	.75	3.50	—	—	22.0
1 1/2 x 1 1/2	1.50	7.50	3.53	6.13	3.69	5.75	7.37	15.50	.640	.705	.38	2.31	4	.88	4.50	6.00	6.50	20.0
2 x 2	2.00	8.50	4.25	6.50	4.51	6.56	8.20	15.50	.640	.705	.44	3.14	8	.75	5.00	6.00	6.50	26.0
2 1/2 x 2*	2.00	9.50	4.69	7.50	4.38	6.06	—	8.50	1.00	.873/.871	—	3.06	8	.88	5.88	—	—	43.7
3 x 3	3.00	11.13	5.82	8.25	6.81	10.25	11.63	20.00	1.28	1.067/1.062	.44	4.43	8	.88	6.63	6.00	6.50	46.0
4 x 4	4.00	12.00	6.00	10.00	8.40	11.00	13.08	20.00	1.28	1.321/1.316	.62	5.88	8	.88	7.88	8.00	9.00	70.0
6 x 6	6.00	15.88	7.94	12.50	12.75	—	15.63	—	2.27	1.950/1.945	.62	8.12	12	.88	10.63	12.00	9.50	157.0
8 x 6	6.00	16.50	6.63	15.00	12.75	—	15.63	—	2.27	1.950/1.945	.62	8.12	12	1.00	13.00	12.00	9.50	275
8 x 8	8.00	19.75	9.88	15.00	16.00	—	21.14	—	3.06	2.497/2.492	.62	10.52	12	1.00	13.00	16.00	11.50	624

KF Series F Split Body Dimensional Data (Model G XXXX)

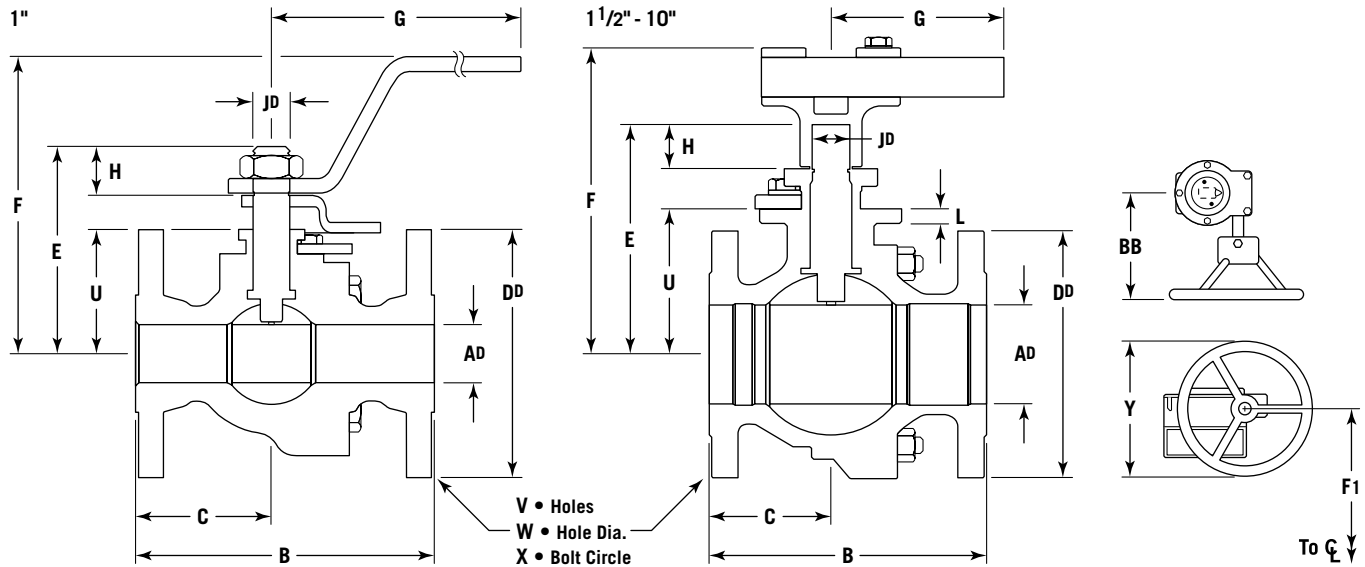

Dimensional Data (mm), 1"-8", Class 150

Size (in.)	Dimension (mm)																	Wt. (kg)
	A	B	C	D	E	F	F1	G	H	J	L	U	V	W	X	Y	BB	
1 x 1	25.4	127	58.7	108.0	88.9	138.2	—	160.3	33.5	14.0	—	42.9	4	16.0	79.5	—	—	—
1 1/2 x 1 1/2	38.1	165.1	75.2	127	93.7	146.1	—	215.9	16.3	17.9	9.7	58.7	4	16.0	98.6	—	—	—
2 x 2	50.8	177.8	76.7	152.4	115.0	166.6	—	215.9	16.3	17.9	11.2	79.8	4	19.1	120.7	—	—	—
2 1/2 x 2*	50.8	190.5	74.7	177.8	111.3	153.9	—	215.9	25.4	22.17/22.12	—	77.7	4	19.1	139.7	—	—	—
3 x 3	76.2	203.2	88.9	190.5	173.0	260.4	—	381	32.5	27.10/26.97	11.2	112.5	4	19.1	152.4	—	—	—
4 x 4	101.6	228.6	101.6	228.6	213.4	279.4	—	457.2	32.5	33.55/33.43	15.7	149.4	8	19.1	190.5	—	—	—
6 x 6	152.4	393.7	196.9	279.4	274.6	282.4	—	1015.9	36.8	38.48/38.35	19.1	203.2	8	22.4	241.3	—	—	—
8 x 6	152.4	457.2	229	342.9	274.6	282.4	397.0	1015.9	36.8	38.48/38.35	19.1	203.2	8	22.4	298.5	400	321	95.3
8 x 8	203.2	457.2	228.6	342.9	362.0	—	463.8	—	57.7	49.53/49.40	16.7	244.9	8	22.4	298.5	400	321	216.4

Dimensional Data (mm), 1"-8", Class 300

Size (in.)	Dimension (mm)																	Wt. (kg)
	A	B	C	D	E	F	F1	G	H	J	L	U	V	W	X	Y	BB	
1 x 1	25.4	165.1	88.9	124.0	88.9	138.2	—	160.3	33.5	14.0	—	42.9	4	19.1	88.9	—	—	—
1 1/2 x 1 1/2	38.1	190.5	89.7	155.7	93.7	146.1	—	215.9	16.3	17.9	9.7	58.7	4	22.4	114.3	—	—	—
2 x 2	50.8	215.9	108.0	165.1	115.0	166.6	—	215.9	16.3	17.9	11.2	79.8	8	19.1	127	—	—	—
2 1/2 x 2*	50.8	241.3	119.1	190.5	111.3	153.9	—	215.9	25.4	22.17/22.12	—	77.7	8	22.4	149.4	—	—	—
3 x 3	76.2	282.7	147.8	210.0	173.0	260.4	—	381	32.5	27.10/26.97	11.2	112.5	8	22.4	168.4	—	—	—
4 x 4	101.6	304.8	152.4	254	213.4	279.4	—	457.2	32.5	33.55/33.43	15.7	149.4	8	22.4	200.2	—	—	—
6 x 6	152.4	403.4	201.7	317.5	323.9	—	—	—	57.7	49.53/49.40	16.7	206.2	12	22.4	270.0	400	321	71.2
8 x 6	152.4	501.7	250.8	381	323.9	—	397.0	—	57.7	49.53/49.40	16.7	206.2	12	25.4	330.2	400	321	124.7
8 x 8	203.2	501.7	251.0	381	406.4	—	537.0	—	77.7	62.31/62.18	16.7	267.2	12	25.4	330.2	600	377	283.0

KF Series F/FE Split Body Dimensional Data (Model GXXXX/E XXXX)

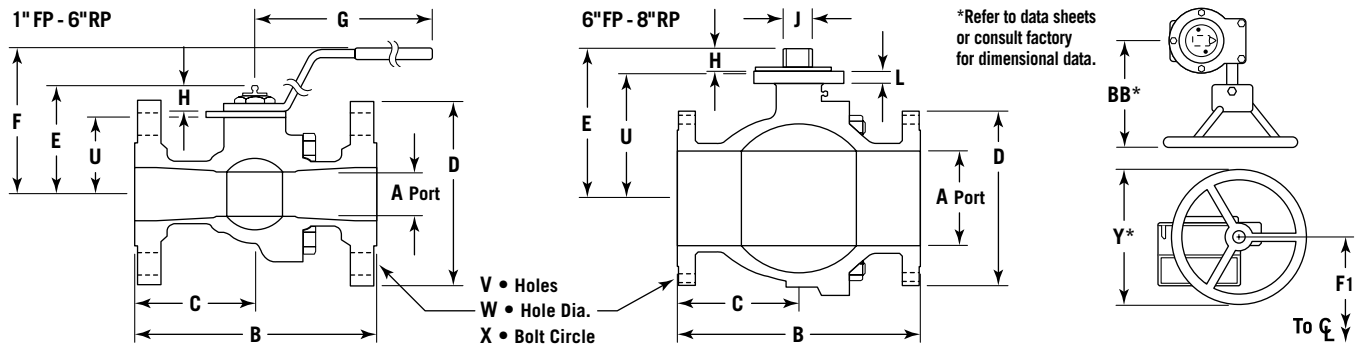

Dimensional Data (in., mm), 1"FP-6"RP, Class 600

Size (in.)	Dimension (in.)																Wt. (lbs.)	Ring Gr.
	A	B/RF	B/RTJ	C/RF	C/RTJ	D	E	F	G	H	J	L	U	V	W	X		
1FP	1.00	8.5	8.50	3.75	3.75	4.88	3.00	4.19	5.88	.81	.623/.621	—	1.69	4	.75	3.50	25.0	R-16
1 1/2 FP	1.50	9.5	9.50	3.88	3.88	6.13	3.94	5.63	8.50	1.00	.873/.871	—	2.63	4	.88	4.50	30.4	R-20
2RP	1.50	11.5	11.63	4.44	4.50	6.50	3.94	5.63	8.50	1.00	.873/.871	—	2.63	8	.75	5.00	35.0	R-23
2FP	2.00	11.5	11.63	4.44	4.50	6.50	4.38	6.06	8.50	1.00	.873/.871	—	3.06	8	.75	5.00	41.5	R-23
2 1/2 RP	2.00	13.0	13.13	4.94	5.00	7.50	4.38	6.06	8.50	1.00	.873/.871	—	3.06	8	.88	5.88	52.9	R-26
3RP	2.00	14.0	14.13	6.00	6.06	8.25	4.38	6.06	8.50	1.00	.873/.871	—	3.06	8	.88	6.63	61.6	R-31
3FP	3.00	14.0	14.13	5.75	5.81	8.25	5.66	7.25	15.00	1.25	1.248/1.246	—	4.00	8	.88	6.63	89.1	R-31
4RP	3.00	17.0	17.13	7.75	7.81	10.75	5.66	7.25	15.00	1.25	1.248/1.246	—	4.00	8	1.00	8.50	133.8	R-37
4FP	4.00	17.0	17.13	8.50	8.56	10.75	8.59	9.50	48.00	1.69	1.791/1.773	.50	6.50	8	1.00	8.50	167.0	R-37
6RP	4.00	22.0	22.13	11.00	11.06	14.00	8.59	9.50	48.00	1.69	1.791/1.773	.50	6.50	12	1.13	11.50	345.0	R-45

Size (in.)	Dimension (mm)																Wt. (kg)	Ring Gr.
	A	B/RF	B/RTJ	C/RF	C/RTJ	D	E	F	G	H	J	L	U	V	W	X		
1FP	25.4	215.9	215.9	95.3	95.3	123.8	76.2	106.4	151.4	20.6	15.62/15.50	—	42.9	4	19.1	88.9	11.3	R-16
1 1/2 FP	38.1	241.3	241.3	98.4	98.4	155.6	100.0	142.9	215.9	25.4	21.84/21.72	—	66.7	4	22.2	114.3	13.8	R-20
2RP	38.1	292.1	295.3	112.7	114.3	165.1	100.0	142.9	215.9	25.4	21.84/21.72	—	66.7	8	19.1	127.0	15.9	R-23
2FP	50.8	292.1	295.3	112.7	114.3	165.1	111.1	154.0	215.9	25.4	21.84/21.72	—	77.8	8	19.1	127.0	18.8	R-23
2 1/2 RP	50.8	330.2	333.4	125.4	127	190.5	111.1	154.0	215.9	25.4	21.84/21.72	—	77.8	8	22.2	149.2	24.0	R-26
3RP	50.8	355.6	358.8	152.4	154.0	209.6	111.1	154.0	215.9	25.4	21.84/21.72	—	77.8	8	22.2	168.3	27.9	R-31
3FP	76.2	355.6	358.8	146.1	147.6	209.6	143.7	184.2	381.0	31.8	31.37/31.24	—	101.6	8	22.2	168.3	40.4	R-31
4RP	76.2	431.8	435.0	196.9	198.4	273.1	143.7	184.2	381.0	31.8	31.37/31.24	—	101.6	8	25.4	215.9	60.7	R-37
4FP	101.6	431.8	435.0	215.9	217.5	273.1	218.3	241.3	1219.2	42.9	45.49/45.03	12.7	165.1	8	25.4	215.9	75.7	R-37
6RP	101.6	558.8	562.0	279.4	281.0	355.6	218.3	241.3	1219.2	42.9	45.49/45.03	12.7	165.1	12	28.6	292.1	156	R-45

Note: 1"FP-6"RP is weight w/handle.
6"FP-8"RP is weight w/gear operator.

Dimensional Data (in., mm), 1"FP, Class 900 & 1500 & 2"RP/FP, Class 900

Size (in.)	Dimension (in.)																Wt. (lbs.)	Ring Gr.
	A	B/RF	B/RTJ	C/RF	C/RTJ	D	E	F	G	H	J	L	U	V	W	X		
1FP	1.00	10.00	10.00	4.75	4.75	5.88	3.06	4.50	5.88	1.13	.623/.621	—	2.00	4	1	4.00	28.0	R-16
2RP	1.50	14.50	14.63	7.25	7.31	8.50	3.94	5.63	8.50	1.06	.873/.871	—	2.63	8	1	6.50	42.9	R-24
2FP	2.00	14.50	14.63	7.25	7.31	8.50	4.38	6.06	8.50	1.06	.873/.871	—	3.06	8	1	6.50	51.2	R-24

Size (in.)	Dimension (mm)																Wt. (kg)	Ring Gr.
	A	B/RF	B/RTJ	C/RF	C/RTJ	D	E	F	G	H	J	L	U	V	W	X		
1FP	25.4	254.0	254.0	120.7	120.7	151.4	77.8	114.3	149.2	28.6	15.62/15.49	—	50.8	4	25.4	101.6	12.7	R-16
2RP	38.1	368.3	371.5	184.2	185.7	215.9	100.0	142.9	215.9	27.0	22.17/22.12	—	66.7	8	25.4	165.1	19.5	R-24
2FP	50.8	368.3	371.5	184.2	185.7	215.9	111.1	154.0	215.9	27.0	22.17/22.12	—	77.8	8	25.4	165.1	23.2	R-24

Note: Weight is w/handle. 2"RP & 2"FP are Class 900 only.

KF Series F/FE Engineering Data

Pressure Temperature

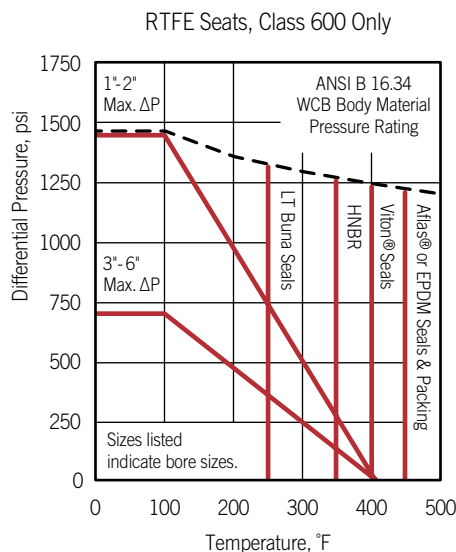
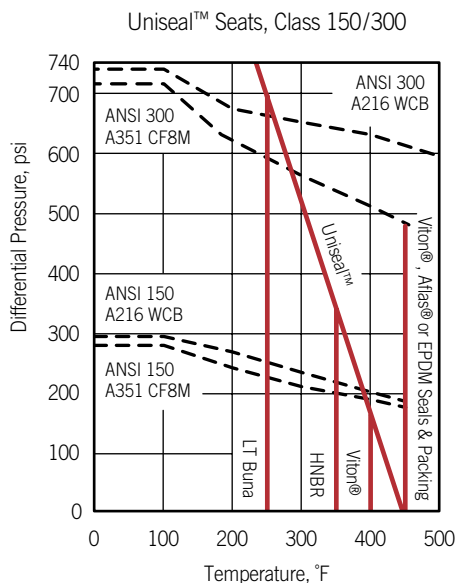
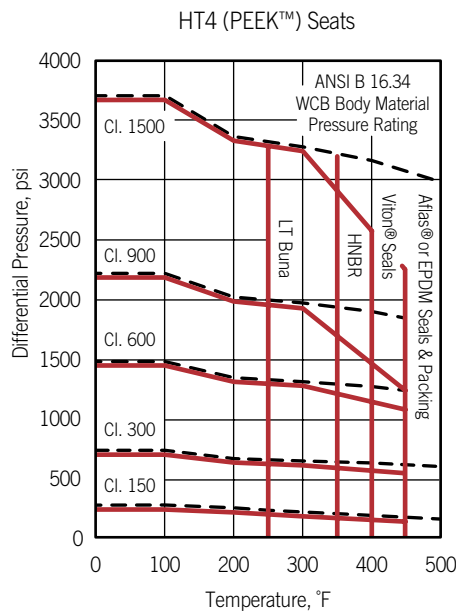
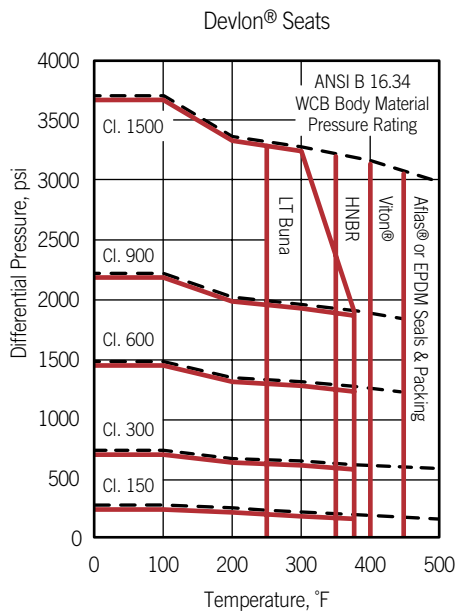

Low Temperature Limits

Body Material	°F	°C
LCC	-50	-45.6
WCB	-20	-28.9
CF8M	-50	-45.6

Seat Material	°F	°C
Devlon® V, Teflon®, HT4 (PEEK™)	-50	-45.6

Seal Material	°F	°C
TFE/GRF Packing	-50°	-45.6
Low Temp Buna N	-50°	-45.6
Viton®	-20°	-28.9
Elast-O-Lion® 985	-50°	-45.6
J. Walker® Viton®	+10°	-12.2
HNBR	-40°	-40
Aflas®	+32°	0
EPDM	-50°	-45.6

Flow Coefficient (C_v)

Size (in.)	Class			
	150	300	600	900/1500
1 FP	95	85	70	65
1 1/2 FP	240	220	195	—
2 RP	165	155	165	175*
2 FP	485	440	380	340*
2 1/2 RP	310	295	285	—
3 RP	190	195	190	—
3 FP	1340	1130	1015	—
4 RP	540	545	455	—
4 FP	2690	2330	1950	—
6 RP	705	780	665	—
6 FP	5640	5580	—	—
8 RP	2140	2160	—	—
8 FP	11,160	10,660	—	—

*Class 900 only

Method of Calculating Flow

The Flow Coefficient “C_v” of a valve is the flow rate of water (gallons/minute) through a fully opened valve, with a pressure drop of 1 psi across the valve. To find the flow of liquid through valve from the C_v, use the following formulas:

Liquid Flow

QL = Flow rate of liquid (gal./min.)
 ΔP = Differential pressure across the valve (psi)
 G = Specific gravity of liquid (for water, G=1)

$$Q_L = C_v \sqrt{\frac{\Delta P}{G}}$$

Gas Flow

Qg = Flow rate of gas (CFH at STP)
 P2 = Outlet pressure (psia)
 g = Specific gravity of gas (for air, g=1.000)

$$Q_g = 61 C_v \sqrt{\frac{P_2 \Delta P}{g}}$$

For non-critical flow

$$\left\{ \frac{\Delta P}{P_2} < 1.0 \right\}$$

KF Series F Topworks & Stem Dimensions (Model GXXXX)

Unibody • Cl. 150 & 300, 2"RP-6"RP
Split Body • Cl. 150 & 300, 1.5"FP-8"FP

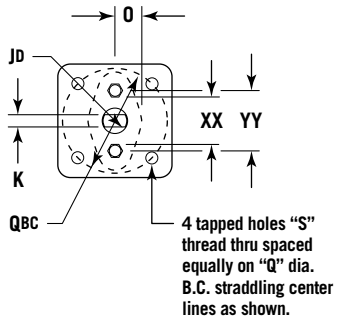

KF Unibody Ball Valves (in., mm), Class 150 & 300

Size (in.)	Class	Dimension (in.)							
		H	J	K	O	Q	S (UNC)	XX	YY
2-3RP	150/300	0.70	.700/.710	.376/.373	0.81	3.25	3/8-16	1.49	2.12
4RP	150/300	1.38	1.067/1.062	.674/.670	1.36	4.13	3/8-16	2.54	3.38
6RP	150/300	1.44	1.321/1.316	.865/.861	1.36	4.41	1/2-13	2.54	3.38
Dimension (mm)									
2-3RP	150/300	17.78	17.78/18.03	9.55/9.47	20.57	82.55	3/8-16	37.85	53.85
4RP	150/300	35.05	27.10/26.97	17.12/17.02	34.54	104.90	3/8-16	64.52	85.85
6RP	150/300	36.58	33.55/33.43	21.97/21.87	34.54	112.01	1/2-13	64.52	85.85

KF Split Body Ball Valves (in., mm), Class 150 & 300

Size (in.)	Class	Dimension (in.)								
		H	J	K	O	Q	S (UNC)	T	XX	YY
1FP	150/300	1.32	.581/.591	.371/.369	.56	—	1/4-20	—	.89	1.38
1.5FP	150/300	.64	.700/.710	.376/.373	.81	3.25	3/8-16	.380	1.49	2.12
2FP	150/300	.64	.700/.710	.376/.373	.81	3.25	3/8-16	.440	1.49	2.12
2.5RP	150/300	1.00	.860/.855	.559/.556	.81	1.75	1/4-20	.440	1.26	1.75
3FP	150/300	1.28	1.067/1.062	.674/.670	1.36	4.13	3/8-16	—	2.54	3.38
4FP	150/300	1.28	1.321/1.316	.865/.861	1.36	4.41	1/2-13	.440	2.54	3.38
6FP/	150	1.45	1.515/1.510	1.065/1.061	1.36	5.13	5/8-11	.760	2.97	4.02
8RP	300	2.27	1.950/1.945	1.249/1.245	1.58	5.13	5/8-11	.620	2.97	4.02
8FP	150	2.27	1.950/1.945	1.249/1.245	1.58	5.13	5/8-11	.620	2.97	4.02
	300	3.06	2.453/2.448	1.749/1.745	2.10	6.75	3/4-10	.620	3.81	5.00
Dimension (mm)										
1FP	150/300	33.53	14.76/15.01	9.42/9.37	14.22	—	1/4-20	—	22.60	35.05
1.5FP	150/300	16.26	17.78/18.03	9.55/9.47	20.57	82.55	3/8-16	9.65	37.85	53.85
2FP	150/300	16.26	17.78/18.03	9.55/9.47	20.57	82.55	3/8-16	11.18	37.85	53.85
2.5RP	150/300	25.40	21.84/21.72	14.20/14.12	20.57	44.45	1/4-20	11.18	32.00	44.45
3FP	150/300	32.51	27.10/26.99	17.12/17.02	34.54	104.90	3/8-16	—	64.52	85.85
4FP	150/300	32.51	33.55/33.43	21.97/21.87	34.54	112.01	1/2-13	11.18	64.52	85.85
6FP/	150	36.83	38.48/38.35	27.05/26.95	34.54	130.30	5/8-11	19.30	75.44	102.11
8RP	300	57.66	49.53/49.40	31.72/31.62	40.13	130.30	5/8-11	15.75	75.44	102.11
8FP	150	57.66	49.53/49.40	31.72/31.62	40.13	130.30	5/8-11	15.75	75.44	102.11
	300	77.72	62.31/62.18	44.42/44.32	53.34	171.45	3/4-10	15.75	96.77	127.00

Split Body • Cl. 150 & 300, 1"FP Only

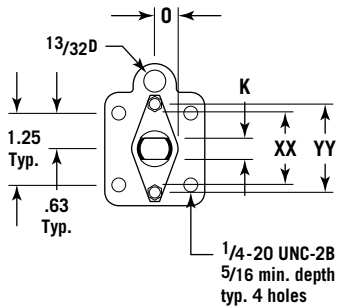

Unibody & Split Body
Cl. 150-1500, 1"FP-8"FP

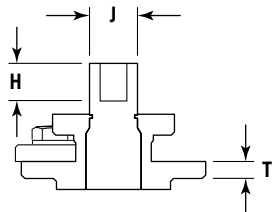

Split Body
Cl. 600, 1"FP-4"RP
Cl. 900, 1"FP-2"RP
Cl. 1500, 1"FP

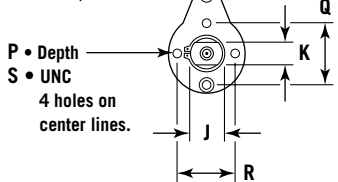

Split Body
Cl. 600, 4"FP-6"RP

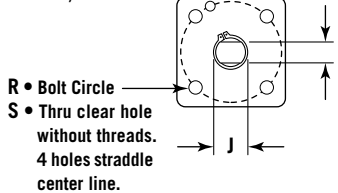

KF Split Body Ball Valves (in., mm), Class 600, 900 & 1500

Size (in.)	Class	Dimension (in.)							
		H	J	K	P	Q	R	S (UNC*)	T
1FP	600	.81	.615/.610	.371/.369	.31	1.25	1.25	1/4-20	—
	900/1500	1.13	.615/.610	.371/.369	.31	1.25	1.25	1/4-20	—
2, 2.5 & 3RP	600	1.00	.860/.855	.559/.556	.38	1.75	1.75	1/4-20	—
1.5-2FP									
2RP/2FP	900	1.06	.860/.855	.559/.556	.38	1.75	1.75	1/4-20	—
3FP/4RP	600	1.25	1.235/1.230	.621/.618	.63	3.13	2.25	5/16-18	—
4FP/6RP	600	1.69	1.750/1.740	1.248/1.246	—	—	4.25	7/16 thru	.495
Dimension (mm)									
1FP	600	20.57	15.62/15.49	9.42/9.37	7.87	31.75	31.75	1/4-20	—
	900/1500	28.70	15.62/15.49	9.42/9.37	7.87	31.75	31.75	1/4-20	—
2, 2.5 & 3RP	600	25.40	21.84/21.72	14.20/14.12	9.65	44.45	44.45	1/4-20	—
1.5-2FP									
2RP/2FP	900	26.92	21.84/21.72	14.20/14.12	9.65	44.45	44.45	1/4-20	—
3FP/4RP	600	31.75	31.37/31.24	15.77/15.70	16.00	79.50	57.15	5/16-18	—
4FP/6RP	600	42.93	44.45/43.18	31.70/31.65	—	—	107.95	7/16 thru	12.57

*4"FP-6"RP is a thru clear hole without threads.

KF Series FE Topworks & Stem Dimensions (Model EXXX)

KF Split Body Ball Valves (in., mm), Class 150, 300 & 600

Size (in.)	Class	Dimension (in.)							
		H	J	K	P	Q	R	S (UNC*)	T
1FP	150/300	1.00	.615/.610	.371/.369	—	—	—	1/4-20	—
	600	.81	.615/.610	.371/.369	.30	1.3	1.25	1/4-20	—
1.5FP	150/300	.99	.860/.855	.559/.556	—	3.3	—	3/8-16	.38
	600	1.00	.860/.855	.559/.556	.40	1.8	1.75	1/4-20	—
2RP	150/300	1.00	.860/.855	.559/.556	—	3.3	—	3/8-16	.38
2FP	150/300	1.02	.860/.855	.559/.556	—	3.3	—	3/8-16	.44
	600	1.00	.860/.855	.559/.556	.40	1.8	1.75	1/4-20	—
3RP	150/300	1.02	.860/.855	.559/.556	—	3.3	—	3/8-16	.44
3FP	150/300	1.22	1.235/1.230	.621/.618	—	4.1	—	3/8-16	.44
	600	1.25	1.235/1.230	.621/.618	.60	3.1	2.25	5/16-18	—
4RP	150/300	1.22	1.235/1.230	.621/.618	—	4.1	—	3/8-16	.44
4FP/	150/300	1.52	1.360/1.355	.746/.743	—	4.4	—	1/2-13	.62
6RP	600	1.69	1.750/1.740	1.248/1.246	—	—	4.25	7/16 thru	.50
6FP	150	1.26	1.557/1.552	1.065/1.061	—	5.1	—	5/8-11	.76
	300	2.38	1.997/1.992	1.249/1.245	—	5.1	—	5/8-11	.62
	600	2.88	2.497/2.492	1.749/1.745	—	—	6.75	3/4-10	.62
8RP	150	1.26	1.557/1.552	1.065/1.061	—	5.1	—	5/8-11	.62
	300	2.38	1.997/1.992	1.249/1.245	—	5.1	—	5/8-11	.62
8FP	150	2.24	1.997/1.992	1.249/1.245	—	5.1	—	5/8-11	.62
	300	2.61	2.497/2.492	1.749/1.745	—	6.8	—	3/4-10	.62
Dimension (mm)									
1FP	150/300	25.40	15.62/15.49	9.42/9.37	—	—	—	1/4-20	—
	600	20.57	15.62/15.49	9.42/9.37	7.62	33.02	31.75	1/4-20	—
1.5FP	150/300	25.15	21.84/21.72	14.20/14.12	—	83.82	—	3/8-16	9.65
	600	25.40	21.84/21.72	14.20/14.12	10.16	45.72	44.45	1/4-20	—
2RP	150/300	25.40	21.84/21.72	14.20/14.12	—	83.82	—	3/8-16	9.65
2FP	150/300	25.91	21.84/21.72	14.20/14.12	—	83.82	—	3/8-16	11.18
	600	25.40	21.84/21.72	14.20/14.12	10.16	45.72	44.45	1/4-20	—
3RP	150/300	25.91	21.84/21.72	14.20/14.12	—	83.82	—	3/8-16	11.18
3FP	150/300	30.99	31.37/31.24	15.77/15.70	—	104.14	—	3/8-16	11.18
	600	31.75	31.37/31.24	15.77/15.70	15.24	78.74	57.15	5/16-18	—
4RP	150/300	30.99	31.37/31.24	18.95/18.87	—	104.14	—	3/8-16	11.18
4FP/	150/300	38.61	34.54/34.41	31.70/31.65	—	111.76	—	1/2-13	15.75
6RP	600	42.93	44.45/44.20	27.05/26.95	—	—	107.95	7/16 thru	12.70
	150	32.00	39.55/39.42	31.72/31.62	—	129.54	—	5/8-11	19.30
6FP	300	60.45	50.72/50.60	44.42/44.32	—	129.54	—	5/8-11	15.75
	600	73.15	63.42/63.30	27.05/26.95	—	—	171.45	3/4-10	15.75
8RP	150	32.00	39.55/39.42	31.72/31.62	—	129.54	—	5/8-11	15.75
	300	60.45	50.72/50.60	31.72/31.62	—	129.54	—	5/8-11	15.75
8FP	150	56.90	50.72/50.60	44.42/44.32	—	129.54	—	5/8-11	15.75
	300	66.29	63.42/63.30	39.55/39.42	—	172.72	—	3/4-10	15.75

*4"FP-6"RP is a thru clear hole without threads.

Split Body • Cl. 150 & 300, 1"FP-8"FP

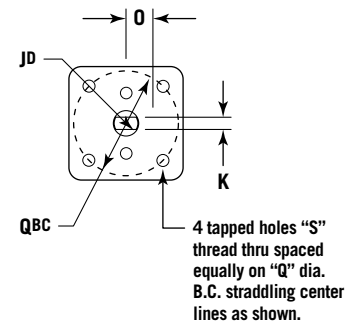

Split Body Cl. 600, 1"FP-4"RP

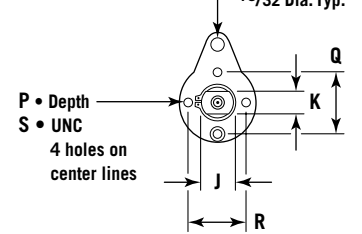

Split Body Cl. 600, 4"FP-6"RP

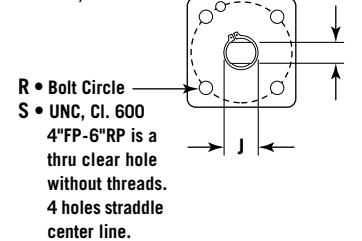

Split Body Cl. 150-600, 1"FP-8"FP

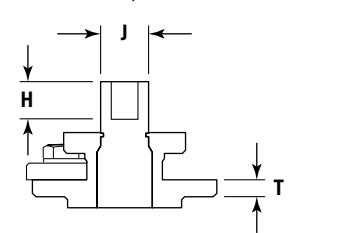

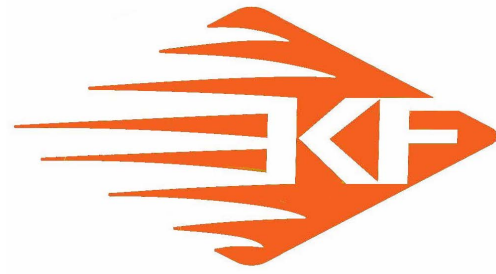

Quality Flow Control Products

Asia | Europe | MiddleEast | NorthAmerica | SouthAmerica

KF Valves LLC is a market-leading, global provider of integrated flow control solutions, specializing in the manufacture of highly engineered valves for critical applications in the oil and gas, power generation, and process industries.

KF Valves LLC

11327 Tanner Road Houston, Texas
77041 United States

www.KFValves.com

Call: 405 631-1533