

DEPARTMENT OF MECHANICAL ENGINEERING

**ME6401- KINEMATICS OF MACHINERY
QUESTION BANK**

Unit 1-BASICS OF MECHANISMS

Part-A

1. Define 'degrees of freedom'.
2. What is meant by spatial mechanism?
3. Classify the constrained motion.
4. What is meant by number synthesis?
5. What are the some important inversions of four chain mechanism?
6. What is toggle position?
7. What is pantograph?
8. What are the applications of single slider crank mechanism?
9. Give some examples for kinematics pairs.
10. Discuss Elliptical trammel
11. What is movability?
12. What is meant by transmission angle?
13. What is meant by Ackermann steering?
14. Write down the Grashof's Law for a four bar mechanism?
15. What is meant by motion adjustment mechanism?
16. Whether a cycle chain is kinematic chain or not?
17. Define instantaneous centre & instantaneous axis?
18. What is link? What are the different types of links?
19. What is meant by spatial mechanism?
20. What is the use of Oldham's coupling?

Part-B

1. a) Explain different types of Link. **(8)**
b) Classify and explain the Kinematic pair. **(8)**
2. a) Explain any two inversion of four bar chain. **(8)**
b) Explain the first inversion of Single Slider Crank Chain. **(8)**
3. Explain first inversion of Double Slider crank chain. **(8)**
4. Explain third inversion of double slider crank chain. **(8)**
5. a) Explain the offset slider crank mechanism. **(8)**
b) Explain Straight line mechanism with neat sketch **(8)**
6. With the help of a neat sketch explain the working of Oldham's coupling.
7. Explain steering gear mechanism with neat sketch
8. With the help of a neat sketch explain the working of Whitworth quick return mechanism.
9. With the help of a neat sketch explain the working of Single slider and double slider crank chain mechanism.

10. a) Design a four-bar crank rocker quick return mechanism to give a time ratio of 1.25 with rocker swing angle as 75° clockwise. Assume the output link (rocker) length as 50 mm and in the left extreme position it is vertical.
- b) Sketch a four-bar crank rocker mechanism in (1) Maximum transmission angle position and (2) toggle position where mechanical advantage is infinity.

Unit 2- KINEMATICS OF LINKAGE MECHANISMS

Part-A

1. What is kinematic analysis?
2. What is displacement?
3. What is vector?
4. Write down the different types of motion.
5. What is Rectilinear motion?
6. What is Curvilinear motion & Circular motion?
7. Define Kennedy's theorem.
8. What is the difference between velocity and speed/
9. What are the different methods are used for finding the velocity?
10. Write the different types of graphical method.
11. What is configuration diagram?
12. What is acceleration & deceleration?
13. What is centrode & space centrode?
14. What is meant by coincident points?
15. What is angular velocity ratio theorem?
16. What are properties of instantaneous centre?
17. What is Body centrode?
18. What is Instantaneous axis?
19. What is axode?
20. Write down the different types of Instantaneous centres.

Part-B

1. The Crank of a slider crank mechanisms rotates clockwise at a Constant speed of 600 r.p.m. The crank is 125 mm and connecting rod is 500 mm long. Determine 1. Linear velocity and acceleration of the mid Point of the connecting rod, and 2. Angular velocity and angular acceleration of the connecting rod, at a crank angle of 45° from inner dead centre position.
2. In a four link mechanism, the dimensions of the links are AB=200 mm, BC=400mm, CD=450 mm and AD=600mm. At the instant when $DAB=90^\circ$, the link AB has angular velocity of 36 rad/s in the clockwise direction. Determine (i) The velocity of point C, (ii) The velocity of point E on the link BC When BE =200 mm (iii) the angular velocities of links BC and CD, iv) acceleration of link of link BC.

3. The dimensions of the various links of a mechanism, as shown in fig. are as follows: $OA=300$ mm; $AB=1200$; $BC=450$ mm and $CD=450$ mm. if the crank OA rotates at 20 r.p.m. in the anticlockwise direction and gives motion to the sliding blocks B and D , find, for given configuration: (1) Velocity of sliding at B and D , (2) Angular velocity of CD (3) Linear acceleration of D and (4) angular acceleration of CD .

4 a) Derive the expressions for Velocity and acceleration of piston in reciprocating steam engine mechanism with neat sketch (8)

b). Derive the expression for Coriolis component of acceleration with neat sketch (8)

5. In a slider crank mechanism, the length of the crank and the connecting rod are 100 mm and 400 mm respectively. The crank [position is 45° from IDC, the crank shaft speed is 600 r.p.m. clockwise. Using analytical method Determine (1) Velocity and acceleration of the slider, and (2) Angular velocity and angular acceleration of the connecting rod.

6. Locate all instantaneous centers of the slider crank mechanism; the length of crank OB and Connecting rod AB are 125 mm and 500 mm respectively. The crank speed is 600 rpm clockwise. When the crank has turned 45° from the IDC. Determine (i) velocity of slider 'A' (ii) Angular Velocity of connecting rod 'AB'.

7. In the mechanism shown in figure, the crank OA rotates at 20 rpm anticlockwise and gives motion of sliding blocks B and D . The dimensions of various links are $OA = 300$ mm, $AB = 1200$ mm, $BC = 450$ mm and $CD = 450$ mm. For the given configuration determine i) velocities of sliding at B and D , ii) angular velocity of CD iii) Linear acceleration of D and iv) angular acceleration of

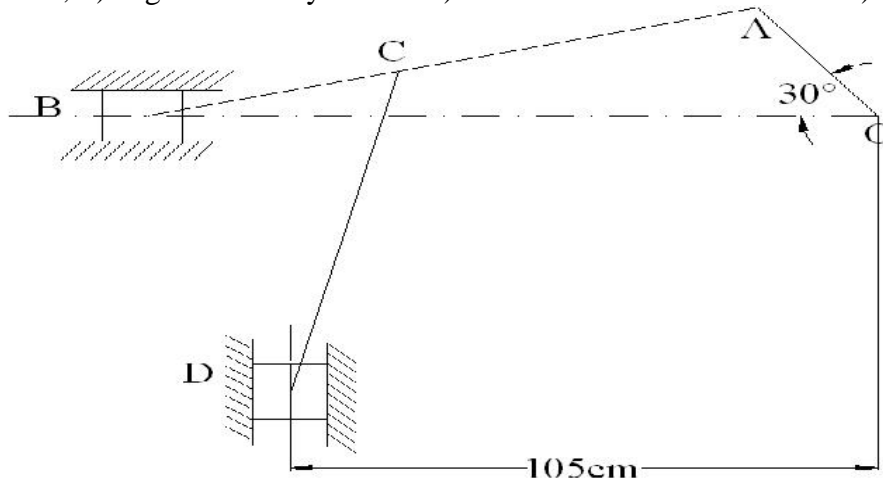

CD.

8. The crank and connecting rod of a theoretical steam engine are 0.5 m and 2m long respectively. The crank makes 180 rpm in the clockwise direction. When it has turned 45° from the inner dead centre position, determine : a) Velocity of piston b) Angular velocity of connecting rod. c) Velocity of point E on the connecting rod 1.5m from the gudgeon pin. d) velocity of rubbing at the pins of the crank shaft, crank and crank cross head when the diameters of their pins are 50mm and 60mm and 30mm respectively.

9. A four-bar mechanism has the following link length in mm. Input, $A_0A = 25$, $AB = 70$, output $BOB_0 = 45$ and frame $A_0B_0 = 60$. Coupler point A is above and B is below the horizontal frame link A_0B_0 , respectively. When the input link is in an angular position of 105° counter clockwise from

the frame link, draw the four bar mechanism and locate all the instantaneous centres. If the input link rotates with a constant angular velocity of 2.5 rad/sec clockwise, determine the linear velocity of B of the output link and the angular velocity of the output link.

10. In a steam engine mechanism shown in figure a) the crank AB rotates at 200 rpm. The dimensions of various links are AB = 12cm, BC = 48cm, CD = 18cm and DE = 36cm, EF = 12 cm and FP = 36cm. Find the velocities of C,D,E,F and P.

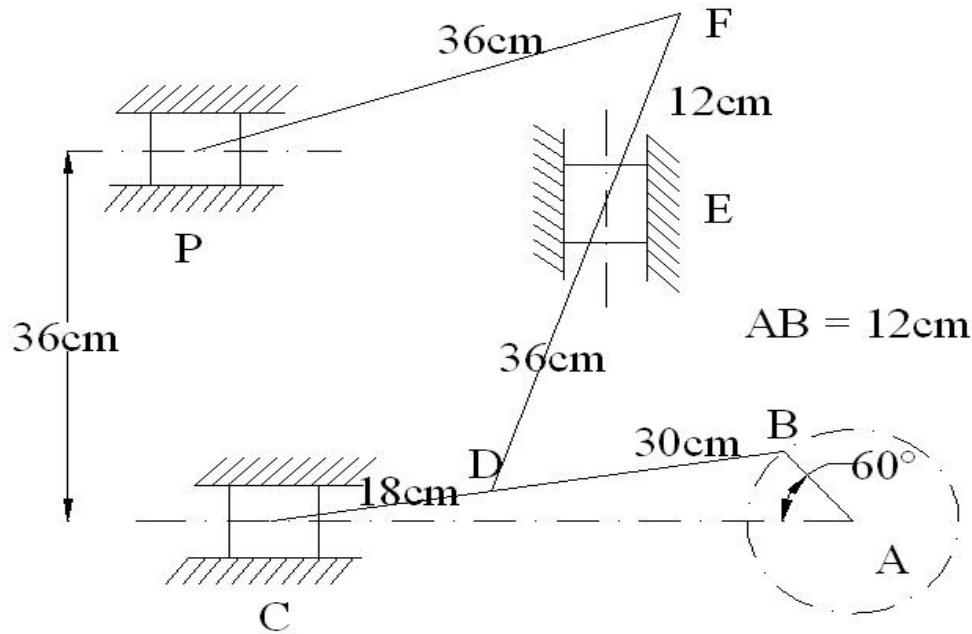

Unit 3- KINEMATICS OF CAM MECHANISMS

Part-A

1. What is a cam?
2. Give some examples of cam.
3. Define tangent cam.
4. What are the different motions of the follower?
5. How can high surface stress in flat faced follower be minimized?
6. Where are the roller follower extensively used?
7. Define dwell period, pitch circle, cam angle?
8. Explain offset follower.
9. Define trace point, prime circle, pressure angle, pitch point
10. Define pressure angle with respect to cams.
12. Define undercutting in cam. How it occurs?
13. What do you know about nomogram?
14. How can you prevent undercutting in cam?

15. What do you know about gravity cam?
16. Write the different types of follower.
17. What is cam profile?
18. What is base circle?
19. What is trace point?
20. What is pitch curve?

Part-B

1. A cam is to give the following motion to a knife edged follower:

- (a) Outstroke during 60° of cam rotation
- (b) Dwell for the next 45° of cam rotation
- (c) Return stroke during next 90° of cam rotation and
- (d) Dwell for the remaining of cam rotation

The stroke of the follower is 40 mm and the minimum radius of the cam is 50 mm. The follower moves with uniform velocity during both the outstroke and return strokes. Draw the profile of the cam when (a) the axis of the follower passes through the axis of the cam shaft, and (b) the axis of the follower is offset by 20 mm from the axis of the cam shaft.

2. Draw the profile of a cam operating a Knife-edged follower from the following data:

- (a) Follower to move outward through 40 mm during 60° of a cam rotation; (b) Follower to dwell for the next 45° (c) Follower to return its original position during next 90° (d) Follower to dwell for the rest of cam rotation. The displacement of the follower is to take place with simple harmonic motion during both the outward and return strokes. The least radius of the cam is 50mm. If the cam rotates at 300 r.p.m., determine the maximum velocity and acceleration of the follower during the outward stroke and return stroke. (16)

3. A cam, with a minimum radius of 50 mm, rotating clockwise at a uniform speed, is required to give a knife-edged follower the motion as described below: (a) To move outwards through 40 mm during 100° rotation of the cam; (b) to dwell for next 80° (c) To return to its starting position during next 90° and (d) To dwell for the rest period of revolution. Draw the profile of the cam (i) When the line of stroke of the follower passes through the centre of the cam shaft and (ii) When the line of stroke of the follower is to take place with Uniform acceleration and uniform retardation. Determine the maximum velocity and acceleration of the follower when the cam shaft rotates at 900 r.p.m. (16)

4. Draw the profile of a cam operating a roller reciprocating follower and with the following data:

Minimum radius of cam = 25 mm; lift = 30 mm; Roller diameter = 15 mm. The cam lifts the follower for 120° with SHM, followed by a dwell period of 30° . Then the follower lowers down during 150° of cam rotation with uniform acceleration and retardation followed by a dwell period. If the cam rotates at a uniform speed of 150 RPM. Calculate the maximum velocity and acceleration of follower during the descent period. (16)

5. It is required to set out the profile of a cam to give the following motion to the reciprocating follower with a flat mushroom contact surface: (i) Follower to have a stroke of 20 mm during 120° of cam rotation, (ii) Follower to dwell for 30° of cam rotation, (iii) Follower to return to its initial position during 120° of cam rotation, (iv) Follower to dwell for remaining 90° of cam rotation. The

minimum radius of the cam is 25 mm. The out stroke of the follower is performed with SHM and return stroke with equal uniform acceleration and retardation. (16)

6. A tangent cam to drive a roller follower through a total lift of 12.5 mm for a cam rotation of 75° . The cam speed is 600 rpm. The distance between cam centre and follower centre at full lift is 45 mm and the roller is 20 mm in diameter. Find the cam proportions and plot displacement, velocity and acceleration for one full cycle.

7. Construct a tangent cam and mention the important terminologies on it. Also derive the expression for displacement, velocity, acceleration of a reciprocating roller follower when the roller has contact with the nose.

8. Layout the profile of a cam operating a roller reciprocating follower for the following data. Lift of follower = 30mm; Angle during the follower rise period = 120; angle during the follower after rise = 30; angle during the follower return period = 150. Angle during which follower dwell after return = 60; minimum radius of cam = 25mm; Roller diameter = 10mm. The motion of follower is uniform acceleration and deceleration during the rise and return period.

9. Design a cam to raise a valve with simple harmonic motion through 15mm in $\frac{1}{3}$ rd of a revolution, keep it fully raised through $\frac{1}{12}$ th of a revolution and to lower it with SHM in $\frac{1}{6}$ th of a revolution. The valve remain closed during the rest of the revolution. The diameter of the roller is 20mm and the minimum radius of the cam is 25mm. The axis of the valve rod passes through the axis of the cam shaft. If the cam shaft rotates at uniform speed of 100 rpm; find the maximum velocity and acceleration of the valve during raising and lowering. Also draw the profile of the cam.

10.a) Classify with neat sketches the cam follower according to their shape, location and motion. State also their advantages, if any, with respect to other followers

b). Sketches neatly the displacement, velocity and acceleration curves of a cycloidal motion follower. Why is it superior over other motion curves?

Unit 4 – GEARS AND GEAR TRAINS

Part-A

1. What is an angle of obliquity in gear?
2. What is bevel gearing? Mention its types.
3. What is meant by arc of approach?
4. What is meant by arc of recess?
5. What is meant by Arc of contact?
6. State law of gearing & contact ratio
7. Define normal and axial pitch in helical gears.
8. What are the methods to avoid interference?
9. What is the advantage when arc of recess is equal to arc of approach in a meshing gears?
- 11 What are the externally applied torques used to keep the gear train in equilibrium?
12. Where will the interference occur in an involute pinion and gear are in mesh having same size of addendum?
13. Define interference & Backlash.
14. What you meant by non standard gear teeth?
15. Define cycloidal tooth profile and involute tooth profile.

16. What is the advantage of a compound gear train over a simple gear train?
17. Where the epicyclic gear trains are used?
18. What are the types of gear trains?
19. Write velocity ratio in compound train of wheels?
20. Define simple gear train, compound gear train & reverted gear train.

Part-B

1. a) Two mating spur gear with module pitch of 6.5 mm have 19 and 47 teeth of 20° pressure angle and 6.5 mm addendum. Determine the number of pair of teeth and angle turned through by the larger wheel for one pair of teeth in contact. Determine also the sliding velocity at the instant (i) engagement commences (ii) engagement terminates. When the pitch line velocity is 1.2 m/s. **(8)**

b) The number of teeth on each of the two spur gears in mesh is 40. The teeth have 20° involute profile and the module is 6mm. If the arc of contact is 1.75 times the circular pitch. Find the addendum. **(8)**

2. a) Two 20° involute spur gears have a module of 10 mm. The addendum is one module. The larger gear has 50 teeth and pinion 13 teeth. Does the interference occur? If it occurs, to what value should the pressure angle be changed to eliminate interference? **(8)**

b) Two mating involute spur gears 20° pressure angle have a gear ratio of 2. the number of teeth on the pinion is 20 and its speed is 250 rpm. The module pitch of the teeth is 12 mm. if the addendum on each wheel wheel recess on each side are half the maximum possible length each, find (1) the addendum for pinion and gear wheel (2) the length of arc of contact (3) the maximum velocity of sliding during approach and recess. Assume pinion to be driver. **(8)**

3.a) A pair of spur gear with involute teeth is to give a gear ratio of 4:1. The arc of approach is not be less than the circular pitch and the smaller wheel is the driver. The angle of pressure is 14.5° . What is the least number of teeth can be used on each wheel? What is the addendum of the wheel in terms of circular pitch? **(8)**

b). A pair 20° full depth involute spur gear having 30 and 50 teeth respectively module 4 mm arc in mesh, the smaller gear rotates at 1000 rpm. Determine (a) Sliding velocities at engagement and disengagement of a pair of teeth and (b) Contact ratio. **(8)**

3. In an epicyclic gear train the internal wheels A and B and compound wheels C and D rotate independently about axis O. The wheels E and F rotate on pins fixed to the arm G. E gears with A and C. Wheel F gear with B and D. All the wheels have the same module and the number of teeth are: $T_C=28$ $T_D=26$; $T_E = T_F=18$. (1) Sketch the arrangement, (2) Find the number of teeth on A and B, (3) If the arm G makes 100 rpm clockwise and A is fixed, find the speed of B, and (4) If the arm G makes 100 rpm clockwise and wheel A makes 10 rpm counter clockwise; Find the speed of wheel B.

4. Two gear wheels mesh externally and are to give a velocity ratio of 3 to 1. The teeth are of involute form; module=6mm, addendum=one module, pressure angle= 20° . The pinion rotates at 90 rpm. Determine (1) the number of teeth on the pinion to avoid interference on it and the corresponding number of teeth on the wheel, (2) The length of path and arc of contact, (3) the number of pairs of teeth in contact. **(16)**

5. The arm of an epicyclic gear train rotates at 100 rpm in the anticlockwise direction. The arm carries two wheels A and B having 36 and 45 teeth respectively. The wheel A is fixed and the arm rotates about the centre of wheel A. Find the speed of wheel B. What will be the speed of B, if the wheel A instead of being fixed, makes 200 rpm (clockwise).

6. In a reverted epicyclic train, the arm F carries two wheels A and D and a compound wheel B-C. Wheel A meshes with wheel B and Wheel D meshes with wheel C. The number of teeth on wheel A, D and C are 80, 48, and 72. Find the speed and direction of wheel D, when wheel A is fixed and arm F makes 200 rpm clockwise.

7. A compound epicyclic gear is shown in figure. The gears A, D and E are free to rotate on axis P. The compound gears B and C rotate together on the axis Q at the end of arm F. All the gears have equal pitch. The number of external teeth on gears, A B and C are 18, 45 and 21 respectively. The gears D and E are annulus gears. The gear A rotates at 100 rpm in anticlockwise direction and the gear D rotates at 450 rpm clockwise. Find the speed and direction of the arm and the gear E.

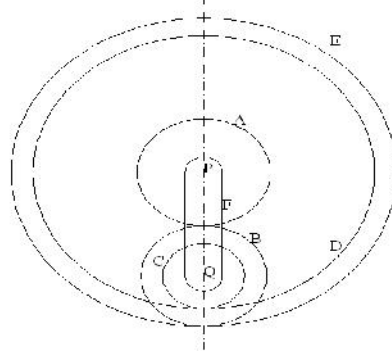

8. The sun planet gear of an epicyclic gear train, the annular D has 100 internal teeth, the sun gear A has 50 external teeth and planet gear B has 25 external teeth. The gear B meshes with gear D and gear A. The gear B is carried on arm E, which rotates about the centre of annular gear D. If the gear D is fixed and arm rotates at 20 rpm, then find the speeds of gear A and B.

9. An epicyclic gear train for an electric motor, is shown in figure. The wheel S has 15 teeth and is fixed to motor shaft rotating at 1450 rpm. The planet P has 45 teeth, gears with fixed annular A and rotates on a spindle carried by an arm which fixed to output shaft. The planet P also gears with the sun when S. Find the speed of output shaft. If motor is transmitting 2 KW find the torque required to fix the annular.

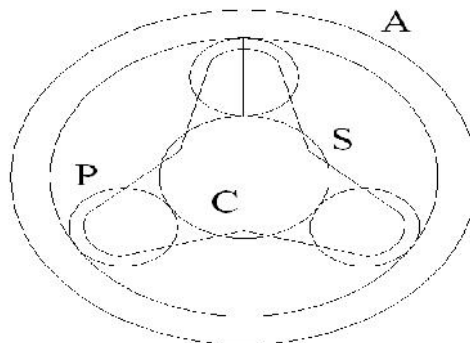

10. An epicyclic gear train as shown in figure is composed of a fixed annular wheel A having 150 teeth. The wheel A is meshing with wheel B which drives wheel D through an idle wheel C, D being concentric with A. The wheels B and C are carried on an arm which revolves clockwise at 100 rpm about the axis of A and D. If the wheels B and D have 25 and 40 teeth respectively, determine the number of teeth on C and speed and sense of rotation of wheel C.

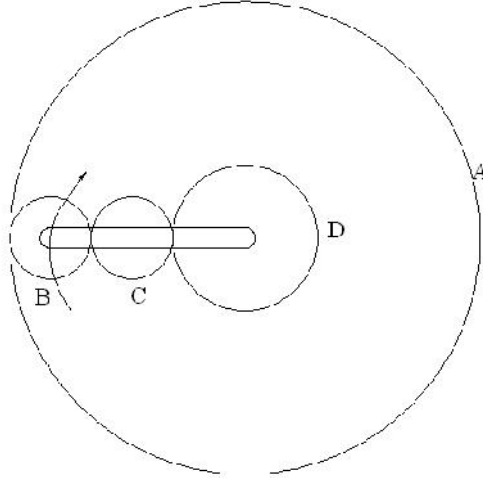

Unit 5- FRICTION IN MACHINE ELEMENTS

Part-A

1. What is dry friction?
2. What is greasy friction?
3. What is fluid friction?
4. State the laws of dry friction.
5. State the laws of fluid friction.
6. What is angle of repose?
7. What is limiting angle of friction?
8. Define Co-efficient of friction.
9. What is the efficiency of the inclined plane?
10. Why self locking screws have lesser efficiency?
11. What are the functions of clutches?
12. What is the difference between cone clutch and centrifugal clutch?
13. What do you mean by crowning in pulley?
14. What are the belt materials?
15. Explain velocity ratio.
16. State the law of belting.
17. What is slip & creep?
17. What is whipping?
18. Explain self energizing
19. What is centrifugal effect on belts?
20. What is the cross belt used instead of open belt?

Part-B

1. a) For a flat belt, prove that $T_1/T_2 = e^{\mu \theta}$ Where T_1 and T_2 = Tension in the tight and slack sides of the belt, θ = Angle of contact between the belt and the pulley, and μ = Coefficient of friction between the belt and the pulley. (8)

b) An open belt running over two pulley of 1.5 m and 1.0 m diameters connects two parallel shafts 4.8 m apart. The initial ten in the belt is 3000 N. The smaller pulley is rotating at 600 rpm. The mass of belt is 0.6703 kg/m length. The coefficient of friction between the belt and pulleys is 0.3. Find (1) the exact length of the belt required (2) the power transmitted taking c.f tension into account. (8)

2.a) A multiplate disc clutch transmits 55 KW of power at 1800 rpm. Coefficient of friction for the friction surfaces is 0.1. Axial intensity at pressure is not to exceed 160 KN/m². The internal radius is 80 mm and

is 0.7 times the external radius. Find the number of plates needed to transmit the required torque. (8)

b) A rope drive is required to transmit 230 KW from a pulley of 1m diameter running at 450 rpm. The safe pull in each rope is 800 N and the mass of the rope is 0.4 kg per meter length. The angle of lap and groove angle 1600 and 450 respectively. If coefficient of friction is 0.3, find the number of ropes required. (8)

3. The mean diameter of the screw jack having pitch of 10 mm is 50 mm. A load of 20 KN is lifted through a distance of 170 mm. Find the work done in lifting the load and efficiency of the screw jack when (i) the load rotates with the screw, and (ii) the load rests on the loose head which does not rotate with screw. The external and internal diameter of the bearing surface of the loose head is 60 mm and 10mm respectively. The coefficient of friction for the screw as well as the bearing surface may be taken as 0.08. (16)

4.a) A leather belt is required to transmit 7.5 kw from a pulley 1.2 m in diameter, running at 250 rpm. The angle entranced is 1650 and the coefficient of friction between the belt and the pulley is 0.3. If safe working stress for the leather belt is 1.5 MPa, density of leather is 1 kg/ m³ and thickness of belt is 10 mm. Determine the width of the belt taking C.F tension into account. (8)

b) Two pulley one 450 mm diameter and other 200mm dia are on parallel shaft 2.1 m apart and are connected by a cross belt. The larger pulley rotates at 225 rpm. The maximum permissible tension in the belt is 1 KN and the coefficient of friction between the belt and the pulley is 0.25. Find the length of the belt required and the power can be transmitted. (8)

5. Two shaft whose centers are 1m apart are connected by a V belt drive. The driving pulley is supplied with 100 KW and has an effective diameter of 300 mm. It runs at 375 rpm. The angle of groove on the pulley is 40° The permissible tension in 400 mm² cross sectional area of the belt is 2.1 MPa. The density of the belt is 1100 kg/ mm³ coefficient of friction is 0.28. Estimate number of belts required. (16)

6.a) Prove or disprove the following statement – “ Angle of friction is equal to angle of repose”

b) Briefly explain the following : 1) Slip of the belt 2) Creep of the belt.

7. A conical pivot bearing supports a vertical shaft of 200mm diameter. It is subjected to a load of 30KN. The angle of cone is 120° and the co-efficient of friction is 0.025. Find the power lost in friction when the speed is 140 rpm assuming i) Uniform pressure and ii) Uniform wear.
8. A single plate clutch is required to transmit 8 KW at 1000 rpm. The axis pressure is limited to 70 KN/m². The mean radius of the plate is 4.5 times the radial width of the friction surface. If both the sides of the plate are effective and the coefficient of friction is 0.25. find a) the inner and the outer radius of the plate and the mean radius, b) the width of the friction lining.
9. A shaft has a number of collars integral with it. The external diameter of the collars is 400mm and the shaft diameter is 250mm. If the uniform intensity of pressure is 0.35N/mm² and its coefficient of friction is 0.05, estimate i) power absorbed in overcoming friction when the shaft runs at 105 rpm and carries a load of 150KN and ii) number of collars required.
- 10.a) Derive an expression for braking torque on the drum of simple band brake.
b.) Deduce the expression for the friction moment of a collar thrust bearing, stating clearly the assumption made.