



KIP 7170 User Manual

Version A.0

Thank you for purchasing the Multi-Function Printer KIP 7170.

This Hardware Operation Guide contains functional and operational explanations for the KIP 7170. Please read this Hardware Operation Guide carefully before using the printer. Please keep this Hardware Operation Guide for future reference.

1. When this product is installed in North America.

This device complies with part 15 of the FCC Rules. Operation is subject to the following two conditions: (1) This device may not cause harmful interference, and (2) this device must accept any interference received, including interference that may cause undesired operation.

Contains FCC ID: VP8-13551

Contains IC: 7391A-13551

2. When this product is installed in Europe

This equipment complies with the requirements in Pub.22 of CISPR Rules for a Class B computing device.

Operation of this equipment in a residential area may cause unacceptable interference to radio and TV reception requiring the operator to take whatever steps are necessary to correct the interference.

Do not install Machine around other electronic equipment or other precision instruments. Other devices may be effected by electrical noise during operation.

If the Machine is installed near other electronic equipment, such as a TV or a radio, interference to said equipment, such as noise or flickering, may occur. Use a separate power line and install the PRINTER as far as possible from said equipment.

KIP 7170 is an ENERGY STAR qualified multifunction device.



The International ENERGY STAR® Office Equipment Program is an international program that promotes energy saving through the penetration of energy efficient computers and other office equipment. The program backs the development and dissemination of products with functions that effectively reduce energy consumption. It is an open system in which business proprietors can participate voluntarily. The targeted products are office equipment such as computers, monitors, printers, facsimiles, copiers, scanners, and multifunction devices. Their standards and logos are uniform among participating nations.

The symbol shown indicates that this product conforms to Directive 2002/96/EC of the European Parliament and the council of 27 January 2003 on waste electrical and electronic equipment (WEEE) and does not apply to countries outside of EU.



Only For EU Member States

The symbol shown indicates that this product conforms to SJ/T11364-2006 of People's Republic of China Electronic Industry Standard and does not apply to countries outside of People's Republic of China.



The symbol shown indicates that this product conforms to GB 18455-2001 11364-2006 of National Standard of the People's Republic of China and does not apply to countries outside of People's Republic of China.



The product shown with available options. May vary from the actual product.

Safety Warnings

The following warnings are very important in order to safely use this product. These notes are important in preventing danger to the operator or operation of the printer.

The following symbols are found throughout the USER'S Manual and have the following meaning:



WARNING

This WARNING mark means that there is a possibility of death or serious injury if you ignore or do not follow the said instruction.



CAUTION

This CAUTION mark means that there is a possibility of injury or physical damage if you ignore or do not follow the said instruction.

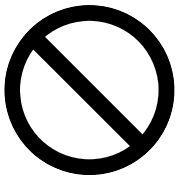

When marked with this symbol, "DO NOT ATTEMPT"



When marked with this symbol, "pay close attention to"



WARNING

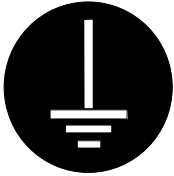

Ground the product with a correct ground source or you may be electrically shocked.



1. The Power source should be as follows:
In U.S.A. : 120V plus/minus10%, 50/60Hz, 15A or higher
In Europe : 220-240V plus6% or minus10%, 50/60Hz, 10A or higher
2. Use a circuit with a dedicated breaker.
3. Install the product as close to the wall outlet as possible.
4. If you wish to move the printer, please contact your service personnel.



1. Do not remove the screw and do not open the cover if not instructed to do so in this User's Manual. If you ignore this warning, you may be burnt or receive an electric shock due to a hot item or electrically charged part inside of the printer.
2. Do not disassemble or tamper with the printer.
It may result in a fire or an electrical shock.

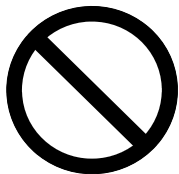

1. Do not plug in the printer into a multi-wire connector in which some other equipment is plugged into.
It may cause a fire due to outlet overheating.
2. Do not damage the Power Cord by stepping on or placing heavy items on it.
If the Power Cord is damaged, it may cause a fire or you may receive an electric shock. **REPLACE THE CORD IF DAMAGED!**

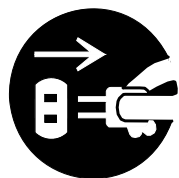

1. Do not put a flower vase, a flowerpot or any water-filled item on the product.
Spilt water could cause a fire or an electric shock.
2. If the product generates an abnormal smell or noise, turn it off and unplug it from the wall electrical outlet immediately.



Do not throw the toner into a fire or other sources of heat, as it can explode.



CAUTION

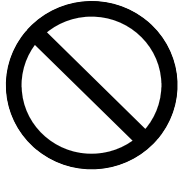

Do not install the printer in a humidified room or a dusty room. Also, do not install the printer on an unstable floor as injuries may occur.

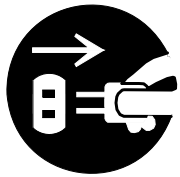

1. Unplug the printer before you move it.
The power cord may be damaged and it may result in a fire or electric shock.
2. If you do not use the printer for a long duration (holidays, company shutdown) turn off and unplug the printer from the outlet for safety.

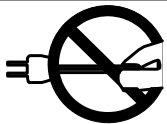

Do not pull the cord when you unplug the printer as you may damage the Power Cord.



There are hot items inside of the printer. Take great care not to touch these items when you remove mis-fed media.



Ventilate the room well if you print in a small area.

POWER CORD INSTRUCTION

The installation of (or exchange to) a power plug which fits in the wall outlet of the installation location shall be conducted in accordance with the following:



WARNING

Select a power plug which meets the following criteria;

- The plug has a voltage and current rating appropriate for the product's rating marked on its name plate.
- The plug meets regulatory requirements for the area.
- The plug is provided with a grounding pin or terminal.

If the appropriate plug does not fit the wall outlet in the installation, the customer shall install an appropriate outlet.

Connector Type:

Configuration	Standard	Rating	Usually found in
	IEC60320:C13	10A 250V (IEC) 15A 125V (UL)	

Plug Type: Model Rating 220-240V

Configuration	Standard	Rating	Usually found in
	CEE7/7	10A 250V	European countries
	KS C 8305	10A 250V	Korea
	AS/NZS 3112	10A 250V	Australia New Zealand
	GB1002 GB2099.1	10A 250V	China
	IRAM 2073	10A 250V	Argentina
	BS 1363	10A 250V	United Kingdom
	SASO 2203	10A 250V	Saudi Arabia
	BS 546A IS-1293 SABS-1293	15A 250V	United Kingdom India South Africa
	SEV 1011	10A 250V	Switzerland

Chapter 1

Before Use

	Page
1.1 Installation Requirements	1- 2
1.2 Originals Prohibited from Duplication	1- 3
1.3 Features	1- 4
1.4 Specifications	1- 5
1.4.1 General	1- 5
1.4.2 Printer part	1- 6
1.4.3 Scanner part	1- 8
1.5 Appearance	1- 9
1.5.1 Front view	1- 9
1.5.2 Rear view	1-10
1.6 Specifications for the Scan Original	1-11
1.7 Specifications for the Printing Paper	1-14
1.7.1 Papers not available to use	1-14
1.7.2 Keeping the paper in the custody	1-15
1.7.3 Treatment against environmental condition	1-16

1.1 Installation Requirements

The following conditions are required for installation of the equipment.



1. **POWER SOURCE** should be rated as follows.
In U.S.A. : 120V plus/minus 10%, 50/60Hz, 15A or higher
In Europe : 220-240V plus 6% or minus 10%, 50/60Hz, 10A or higher
2. The equipment must be on an exclusive circuit.
3. The outlet must be near the equipment and easily accessible.

I Norge: Kan kobles til IT strøm distribusjonssystemer.



1. Make sure to connect this equipment to a grounded outlet.
2. For **PLUGGABLE EQUIPMENT**, the socket-outlet shall be installed near the equipment and shall be easily accessible.

The site temperature range = 10 to 32 degrees Centigrade, with the humidity between 15% to 85% RH. (NON CONDENSING)

Keep the printer away from water sources, boilers, humidifiers, refrigerators or kerosene (oil) stove.



1. The installation site must not have open flames, dust or ammonia gases.
2. The equipment must not be exposed to the air vents from air conditioners. It may affect the image quality.
3. The equipment should not be exposed to the direct sunlight. Please draw curtains to block any sunlight. When you open the Movable Unit, do not expose the Photoconductive Drum to strong (intense) light as this will damage the Drum.



Ozone will be generated while this equipment is use, although the quantity generated is within safe levels. (see certifications)
Ventilate the room, if required.

Keep ample room around the equipment to ensure comfortable operation.
(Refer to the following figure.)

The equipment must be leveled and the floor strength must be ample to sustain the weight of the equipment.

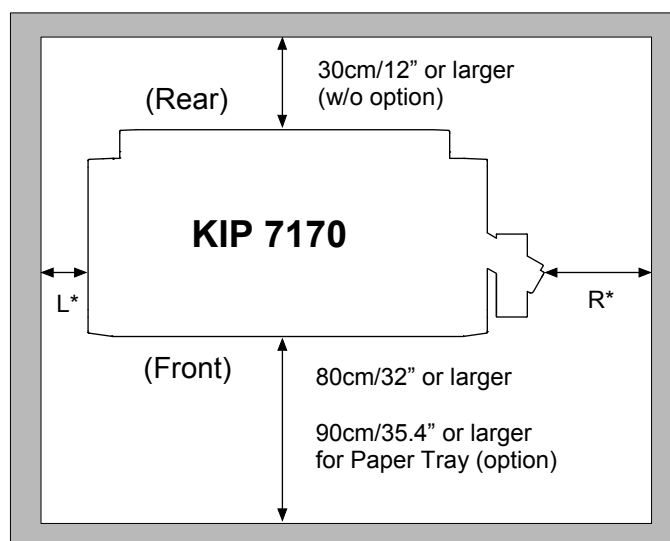

* $L + R = 35\text{cm}/14''$ or larger
(R must be larger than L)
(L = $5\text{cm}/2''$ or larger recommended)

1.2 Originals Prohibited from Duplication

It is not necessarily allowed to copy every kind of original.

You may be punished by the law if only you possess the copy of some kind of original.

We recommend you to consider enough before you copy such original.

[Originals prohibited from copying by the law]

1. It is not allowed to copy Currency (Bill, Money, Bank Note, etc.), Government issued Negotiable Instruments (National Bonds, Security, Local Debt Bonds, etc.).
2. It is not allowed to copy Foreign Currency or Foreign Negotiable Instruments.
3. It is not allowed to copy unused postal stamps or government postcards without permission to make replica from Government.
4. It is not allowed to copy Government issued revenue stamps, certificate stamps which are prescribed by Liquor Tax Act or the Commodity Tax Act.

[Special items to be cared]

1. It is warned by the government to copy private issued securities (stock certificate, draft, check, goods ticket, etc.), commutation ticket or book of tickets, excluding that some specific company copies such originals as many as it requires for its own business.
2. We recommend you not to copy freely such originals as government issued passport, public or private issued licenses, automobile inspection certification, IDs and tickets like pass or meal.

Reference Law	Prohibited items to copy
Regulations to control fake currency and Bond.	Currency (Bill, Money, Bank Note, etc.), Government issued Negotiable Instruments (National Bonds, Security, Local Debt Bonds, etc.)
Control Law against Forged & faked Foreign Currency, Bill, Bank Note and Bond	Foreign Currency or Foreign Negotiable Instruments
Forged postal stamps control law	Unused postal stamps or government postcards
Forged revenue stamps control law	Government issued revenue stamps, and certificate stamps prescribed by Liquor Tax Act or Commodity Tax Act
Currency similarity securities Control Law	Private issued securities (stock, draft, check, goods ticket, etc.), commutation or book tickets

[Originals protected by the copyright]

It is prohibited to copy such originals as book, music, paintings, printed copy, maps, drawings, movie and pictures which are protected by the copyright, except for personnel or family use or similar purpose.

1.3 Features

- (1) The KIP 7170 is a single footprint Multi-Function Printer which can copy, scan and print. Advanced drivers and comprehensive print utilities make the KIP 7170 an advanced, easy to use system. (some functions may be optional)
- (2) KIP HDP technology generates no waste toner.
- (3) The combination of the KIP HDP Plus imaging system with mono-component minute toner produces high definition lines, distinctive greyscale and consistent blacks.
- (4) The maximum paper width is 36" (914mm) wide, and the minimum is 11" (279mm). The maximum paper length is 6m (with 36" paper) or, and the minimum is 8.5" (210mm).
- (5) Up to 600dpi print resolutions with an enhanced scanning system produces the highest quality images controlled by an advanced KIP Image Process System.
- (6) Easy access to USB port allows users to provide efficient productivity by using "File to Print" / "Scan to USB" (option).
- (7) 2-way print delivery (front, up to 50 sheets of plain paper / rear) suits the preference of the user's print handling. (rear stacking requires a stacking device, option)
- (8) Various media source; roll media feeding (2 rolls), cut sheet manual feeding, Paper Tray multiple cut sheet feeder (option)
- (9) Contactless IC card reader for more efficient accounting management (option)
- (10) The KIP 7170 adopts 12.1 inch screen for the UI, wider than 10.4 for our old products. The capacitive multi-touch screen offers smooth, various and intuitive user operation that a pressure sensing device lacks.

1.4 Specifications

1.4.1 General

Subject	Specification
Model	KIP 7170
Configuration	Console
Power consumption (Maximum)	1,440W (US model) 1,680W (EU / Asia model) (scanner / controller included)
Power consumption (Low power mode)	8.2W or less
Acoustic noise	Idling Max. 50db Printing Max. 57db (impulse sound excluded) EN ISO 7779
Ozone	Max. 0.05ppm (Measurement method under UL Standard)
Dimensions	1346mm (Width) x 704mm (Depth) x 1105mm (Height) (UI, Tray excluded)
Weight	About 244kg (538lb)
Environmental condition for usage	(Temperature) 10 to 32 degrees Centigrade / 50 to 89.6 F (Humidity) 15 to 85% RH
Interface	Network Interface (10 BASE-T / 100 BASE-TX / 1000 BASE-T) USB2.0 (5VDC max)
Rating Input Power	In the US : 120V plus/minus 10%, 50/60Hz, 15A In Europe : 220-240V plus 6% or minus 10%, 50/60Hz, 10A

NOTE

The above specifications are subject to change without notice.

1. 4. 2 Printer part

Subject	Specification																																																																				
Printing method	LED Array Electro photography																																																																				
Photoreceptor	Organic Photoconductive Drum																																																																				
Print speed	80mm per second (Inch) 3.4ppm/E 5.8ppm/D Landscape (Metric) 3.3ppm/A0 5.6ppm/A1 Landscape																																																																				
Print head	LED Array																																																																				
Resolution of print head	600dpi x 2400dpi																																																																				
Print width	Maximum 914mm / 36" Minimum or 297mm / 11" (roll media) or 210mm / 8.5" (cut sheet)																																																																				
Print length	Maximum (Standard) 6,000mm / 19.7ft for 36" / A0 wide (plain paper / bond) or "5 x Standard length" (plain paper / bond) "2 x Standard length" (tracing paper / vellum) "1 x Standard length" (film) (Option) 200,000mm Minimum 210mm / 8.5" <div style="border: 1px solid black; padding: 5px; margin-top: 10px;"> <p>! NOTE</p> <p>If the print is longer than 6,000mm, its image quality or the reliability of paper feeding is not guaranteed.</p> </div>																																																																				
Print size (from Paper Tray, option)	ISO (mm) Length Width <table border="1" style="display: inline-table; margin-left: 20px;"> <tr> <td style="width: 20px;"></td> <td style="width: 20px;"></td> <td style="width: 40px;">594</td> <td style="width: 40px;">420</td> <td style="width: 40px;">297</td> <td style="width: 40px;">210</td> </tr> <tr> <td style="width: 20px;">420</td> <td style="width: 20px;">X</td> <td></td> <td></td> <td style="width: 20px;">X</td> <td></td> </tr> <tr> <td style="width: 20px;">297</td> <td></td> <td style="width: 20px;">X</td> <td></td> <td></td> <td style="width: 20px;">X</td> </tr> </table> ANSI (inch) Length Width <table border="1" style="display: inline-table; margin-left: 20px;"> <tr> <td style="width: 20px;"></td> <td style="width: 20px;"></td> <td style="width: 20px;">24</td> <td style="width: 20px;">22</td> <td style="width: 20px;">18</td> <td style="width: 20px;">17</td> <td style="width: 20px;">12</td> <td style="width: 20px;">11</td> <td style="width: 20px;">9</td> <td style="width: 20px;">8.5</td> </tr> <tr> <td style="width: 20px;">18</td> <td style="width: 20px;">X</td> <td></td> <td></td> <td></td> <td></td> <td style="width: 20px;">X</td> <td></td> <td></td> <td></td> </tr> <tr> <td style="width: 20px;">17</td> <td></td> <td style="width: 20px;">X</td> <td></td> <td></td> <td></td> <td></td> <td style="width: 20px;">X</td> <td></td> <td></td> </tr> <tr> <td style="width: 20px;">12</td> <td></td> <td></td> <td style="width: 20px;">X</td> <td></td> <td></td> <td></td> <td></td> <td style="width: 20px;">X</td> <td></td> </tr> <tr> <td style="width: 20px;">11</td> <td></td> <td></td> <td></td> <td style="width: 20px;">X</td> <td></td> <td></td> <td></td> <td></td> <td style="width: 20px;">X</td> </tr> </table>			594	420	297	210	420	X			X		297		X			X			24	22	18	17	12	11	9	8.5	18	X					X				17		X					X			12			X					X		11				X					X
		594	420	297	210																																																																
420	X			X																																																																	
297		X			X																																																																
		24	22	18	17	12	11	9	8.5																																																												
18	X					X																																																															
17		X					X																																																														
12			X					X																																																													
11				X					X																																																												
Warm up time	Shorter than 4 minutes 30 seconds (At 23°C, 60%RH, the rated voltage, and plain paper is used)																																																																				
First print time	21 seconds (D Landscape, Front Stacking) (At 23°C, 60%RH, the rated voltage, and plain paper is used)																																																																				
Fusing method	Heat and Pressure Rollers																																																																				
Development method	Dry type non-magnetic mono-component toner																																																																				

! NOTE

The above specifications are subject to change without notice.

Subject	Specification
Media source	2 Roll Decks Manual Feeder (single cut sheet) Paper Tray (multiple cut sheet, option)
Media	(Recommended Media) US model: Bond 64g/m ² to 80g/m ² , US Bond (PB-20) Vellum US Vellum (XV-20) Film 4MIL (PF-4DDME) Europe/Asia model: Plain Paper 64g/m ² to 80g/m ² , Oce Red Label (75g/m ²) Tracing Paper Oce Transparent Paper (80g/m ²) Film Oce 3.5MIL
Storage of consumables	(Toner cartridge) Store the cartridge within the temperature range from 0 to 35 degrees Centigrade and within the humidity range from 35 to 85% RH.

 **NOTE**

The above specifications are subject to change without notice.

1. 4. 3 Scanner part

Subject	Specification
Scanning method	Contact Image Sensor (CIS) (5 pieces of A4 sized CIS)
Light source	LED (R/G/B)
Setting of original	Face up
Starting point of scan	Center
Scan width	Max: 914.4mm / 36" Min : 210mm
Scan length	Max: 6,000mm / 19.7ft (Including the margin area) (If the print is longer than 6,000mm, its image quality or the reliability of paper feeding is not guaranteed.) Min : 210mm / 8.5" (Including the margin area)
Margin area	3mm from leading, trailing and both side edges
Optical resolution	600dpi
Digital resolution	200 / 300 / 400 / 600 dpi
Original transportation	Sheet through type
Transportable original thickness	Max: 1.60mm Min : 0.05mm <div style="border: 1px solid black; padding: 5px; margin: 10px 0;"> <p>! NOTE</p> <p>Image quality for an original with 0.25mm or thicker is guaranteed only in a standard size even the scanner physically accepts it.</p> </div>
Scanning speed (600 dpi, normal quality) (max)	Monochrome : 65mm/s Grayscale : 65mm/s Color : 22mm/s The actual speed may vary by the scan software.

! NOTE

The above specifications are subject to change without notice.

1.5 Appearance

1.5.1 Front view

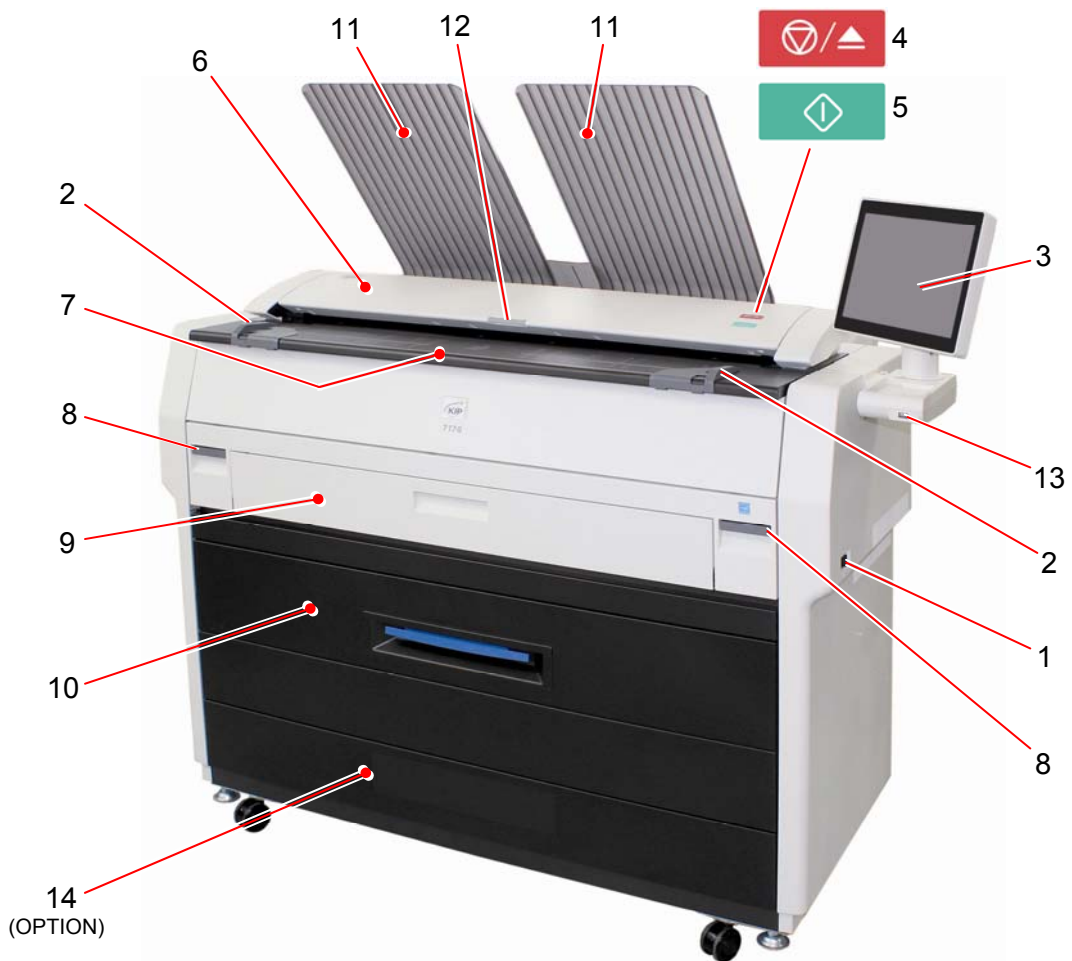

No.	Name	Function
1	Main Switch	You can turn on/off the KIP 7170.
2	Original Guides	Feed the original under the Scanner Unit along the Original Guides.
3	User Interface	This is a Touch Screen, and many kinds of user operation are available. PLEASE DO NOT push the LCD area too strong.
4	Scan Abort Button	While scanning: emergency stop At Standby position: eject
5	Start Button	Starts scanning if the controlling software requires user intervention.
6	Scanner Unit	Read the original with this unit when you make scan or copy.
7	Toner Hatch (Original Table)	Open the Toner Hatch when you replace the Toner Cartridge. Also put the original here and then feed it into the Scanner Unit when you make scan or copy.
8	Engine Unit Open Lever	Pull up these levers when you open the Engine Unit.
9	Bypass Feeder	Feed a cut sheet paper from the Bypass Feeder.
10	Roll Deck	Roll media can be loaded here.
11	Print Tray	These trays catch ejected prints.
12	LED Indicator	Indicates the status of Scanner Unit. green: Ready red: Error green to-and-fro: Scanning red flashing:Scanner Unit Open, Jam
13	USB Port	Your USB flash memory storage can be installed here. 5VDC max.
14	Paper Tray (OPTION)	Multiple cut sheets can be stored inside (up to 50)

1. 5. 2 Rear view



No.	Name	Function
1	Exit Cover	Open the Exit Cover when you remove the paper misfed inside the Fuser Unit.
2	COM Port (Optional)	For an optional device (D-Sub Connector 9 pins: 12VDC max.)
3	USB Port	For an optional device Service Use. 5VDC max.
4	LAN Port	Connect the LAN Cable to connect the KIP 7170 to the network. (Do not connect a telephone line)
5	Dehumidify Heater Switch (Optional in the US)	Turn on the Dehumidify Heater with this switch when you would like to dry the paper in the humid season.
6	Breaker	It is possible to shut off supplying the AC power.
7	Inlet Socket	Connect the Power Cord here.

1. 6 Specifications for the Scan Original

A scan original must satisfy the following specifications.

Thickness	0.05mm to 1.6mm *1
Width	210mm to 914.4mm
Length	210mm to 6000mm *2

*1. Image quality for an original with 0.25mm or thicker is guaranteed only in a standard size even the scanner physically accepts it.

*2. Image quality for an original over 6,000mm in length is not guaranteed.

Do not scan the following kinds of originals. The original or the scanner may damage.

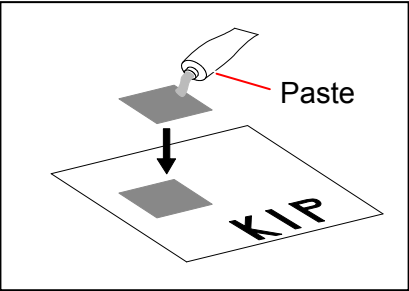
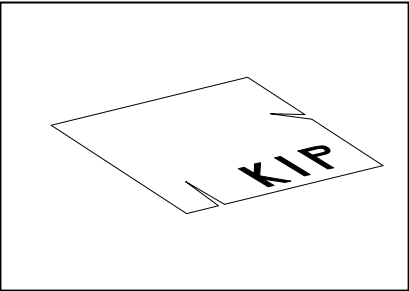
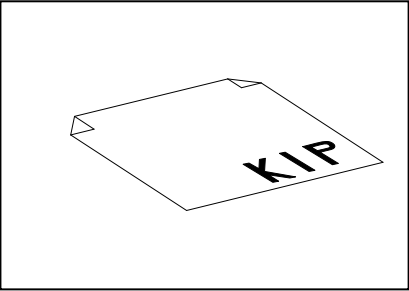
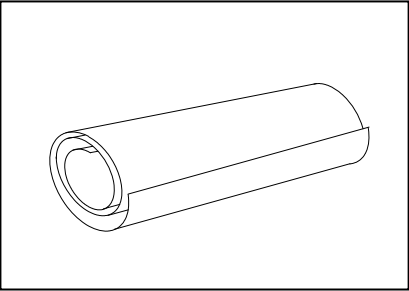
Sticked with paste	
Torn	
Folded (Leading edge)	
Excessively curled (a diameter of 80 mm or less)	

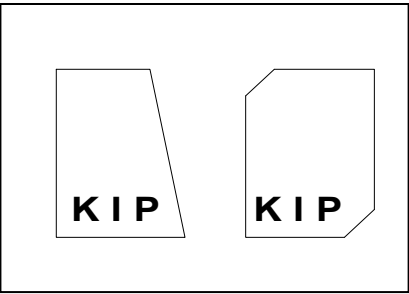
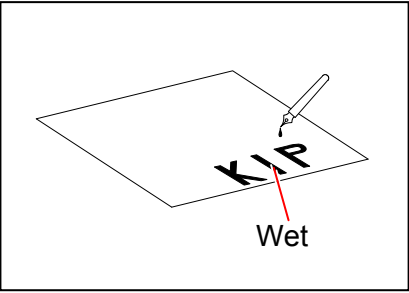
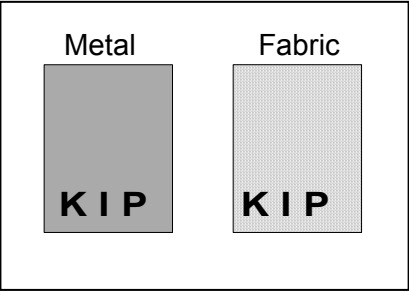
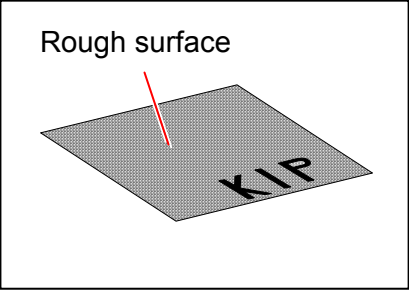
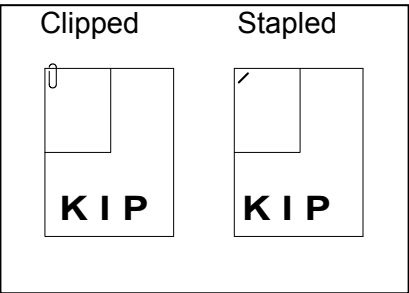
<p>Not square</p>	
<p>Wet</p>	
<p>Metal or fabric material</p>	
<p>Rough surface (Carbon paper for example)</p>	
<p>Clipped or stapled</p>	

The following kinds of originals can be read with using a carrier sheet.
Image quality or the reliability of paper feeding for them is not guaranteed.

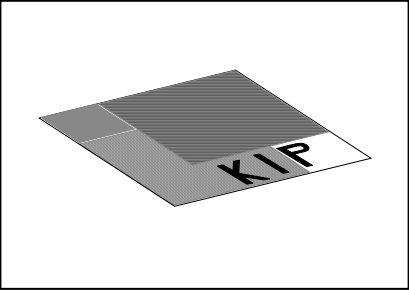
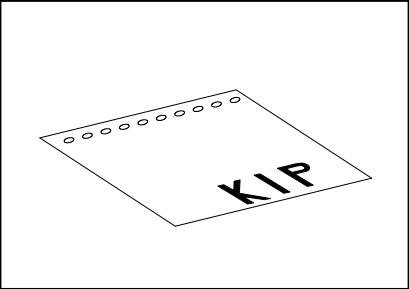
Patched	 An illustration of a document with a dark, textured patch covering the top-left portion. The letters 'KIP' are printed in the bottom-right corner of the document.
Punched	 An illustration of a document with a series of small circles along the top edge, representing punch holes. The letters 'KIP' are printed in the bottom-right corner of the document.

1.7 Specifications for the Printing Paper

1.7.1 Papers not available to use

Do not use the following kinds of printing paper. Doing so may damage the print engine.

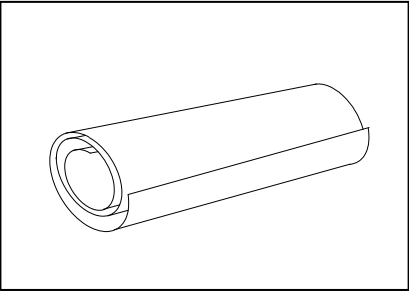
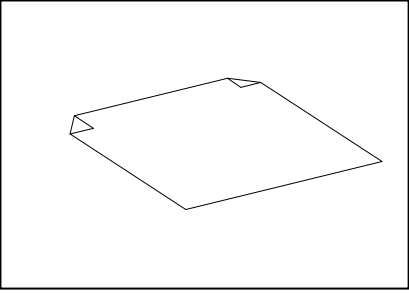
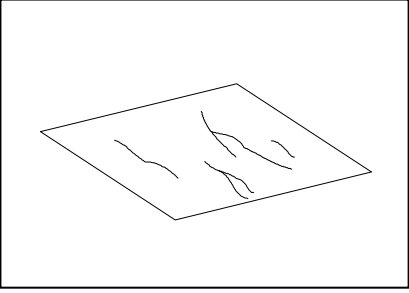
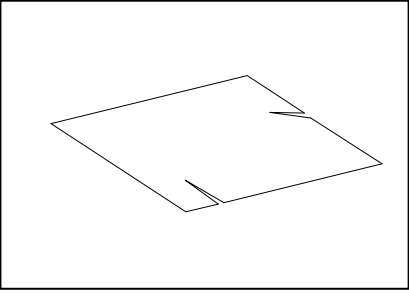
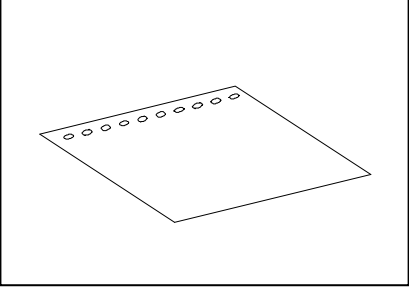
Excessively curled (a diameter of 50 mm or less)	
Folded	
Creased	
Torn	
Punched	

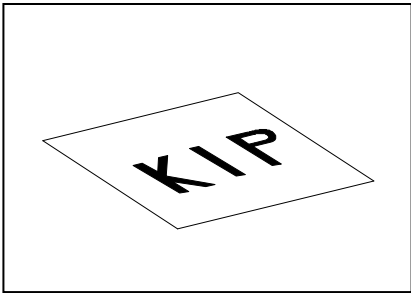
Pre-printed	
Extremely slippery	
Extremely sticky	
Extremely thin and soft	
OHP Film	

CAUTION

Do not use the paper with staple, or do not use such conductive paper as aluminium foil and carbon paper.

The above may result in a danger of fire

NOTE

- (1) Print image may become light if printed on a rough surface of the paper.
- (2) Print image may become defective if the print paper has an excess curl.
- (3) It will become a cause for paper mis-feed, defective print image or paper creasing if you use a paper that does not satisfy the specification.
- (4) Do not use a paper of which surface is very special, such as thermal paper, art paper, aluminium foil, carbon paper and conductive paper.
- (5) Do not use papers with unpacked (exposed in high / low temperature & humidity) in a long period. Such papers may result in mis-feed, defective image or paper creasing.
- (6) Tracing paper exposed to air over a long period tends to cause a defective printing. Removing one round on the surface of the tracing roll paper from the beginning is recommended.
Refer to [2.3 Replacing Roll Media].

1. 7. 2 Keeping the paper in the custody

Keep the paper in the custody taking care of the following matters.

1. Do not expose the paper to the direct sunlight.
2. Keep the paper away from high humidity. (It must be less than 70%)
3. Put the paper on a flat place
4. If you will keep the paper in the custody, which you have already unpacked, put it into the polyethylene bag to avoid the humidity.

1.7.3 Treatment against environmental condition

Take a necessary treatment according to the environmental condition as shown below.

Humidity(%)	Possible problem	Necessary treatment
Low ↑	“Void of image”, “crease of paper” and other problems occurs when you print with plain paper and tracing paper.	1. Install the humidifier in the room, and humidify the room air. 2. Remove the paper from the machine right after the completion of print, and keep it in a polyethylene bag.
40%	“Void of image” occurs when you print with tracing paper.	If you will not make print soon, remove the tracing paper from the machine and keep it in a polyethylene bag.
70%		Remove the paper from the machine after everyday use, and keep it in a polyethylene bag.
High ↓	“Void of image”, “crease of paper” and other problems occurs when you print with plain paper and tracing paper.	1. Turn on the Dehumidify Heater. (if installed) 2. Remove the paper from the machine right after the completion of print, and keep it in a polyethylene bag.

⚠ NOTE

- (1) KIP 7170 is equipped with the Dehumidify Heater (optional for the US). Using it in high humidity environment (75% or higher) is recommended. Refer to [2.9 Dehumidifying Roll Paper].
- (2) “Void of image” and “crease of paper” will occur in case of extremely high or low humidity.

Normal Print

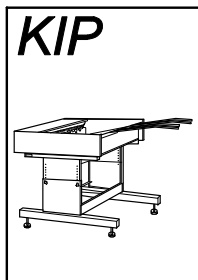

If the media is humidified;

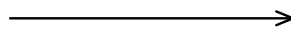

Crease of paper

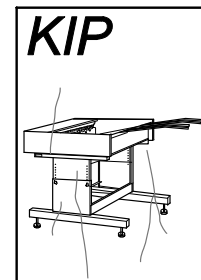

Normal Print



If the media is humidified;

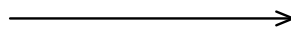

Loss of image

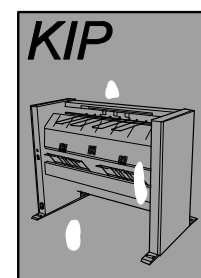

Chapter 2

Basic Operation

	Page
2.1 Turning on KIP 7170	2- 2
2.2 Turning off KIP 7170	2- 4
2.3 Replacing Roll Media	2- 5
2.4 Replacing Toner Cartridge	2-11
2.5 Cut Sheet Media	2-15
2.6 Copying	2-16
2.7 Emergency Stop of Scan or Copy	2-18
2.8 Canceling Sleep Mode	2-19
2.9 Dehumidifying Roll Media	2-20

2. 1 Turning on KIP 7170

1. Ensure that the KIP 7170 is plugged into a dedicated wall outlet.

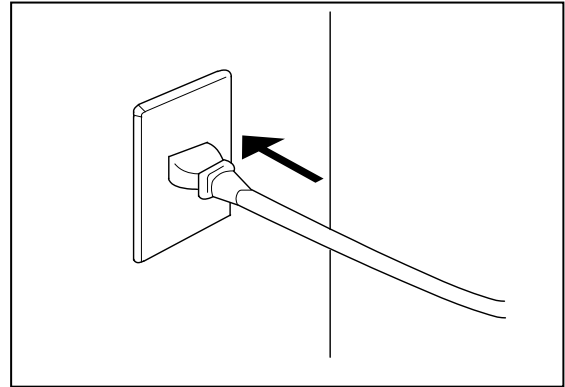

⚠ WARNING

- (1) Do not handle the Power Plug with wet hands, or you may receive an electrical shock.
- (2) Make sure to earth the machine for safety.
- (3) Do not plug the printer into a multi-wiring connector in which other devices are plugged. It may overheat the outlet and may result in a fire.
- (4) The **OUTLET** must satisfy the following conditions.
 - In the U.S.A. : 120V plus/minus 10%, 50/60Hz and 15A
 - In Europe : 220-240V plus 6% or minus 10%, 50/60Hz and 10A

2. Press “ | ” side the Power Switch on the right side of the printer to turn on the KIP 7170.



Power Switch

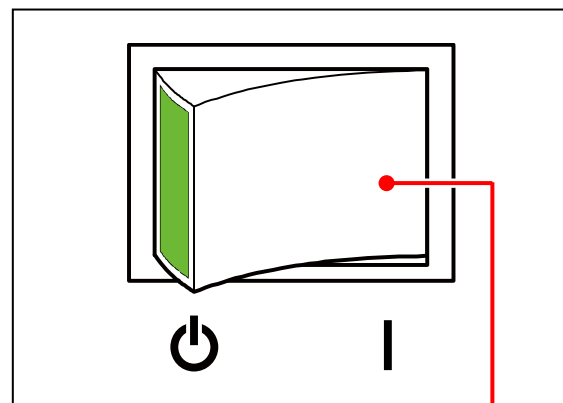

Press “ | ” side.

3. The User Interface (UI) starts operating, and displays the following Copy Mode Screen in one minute.

The Ready Indicator on Copy Mode Screen will flash during warming up.

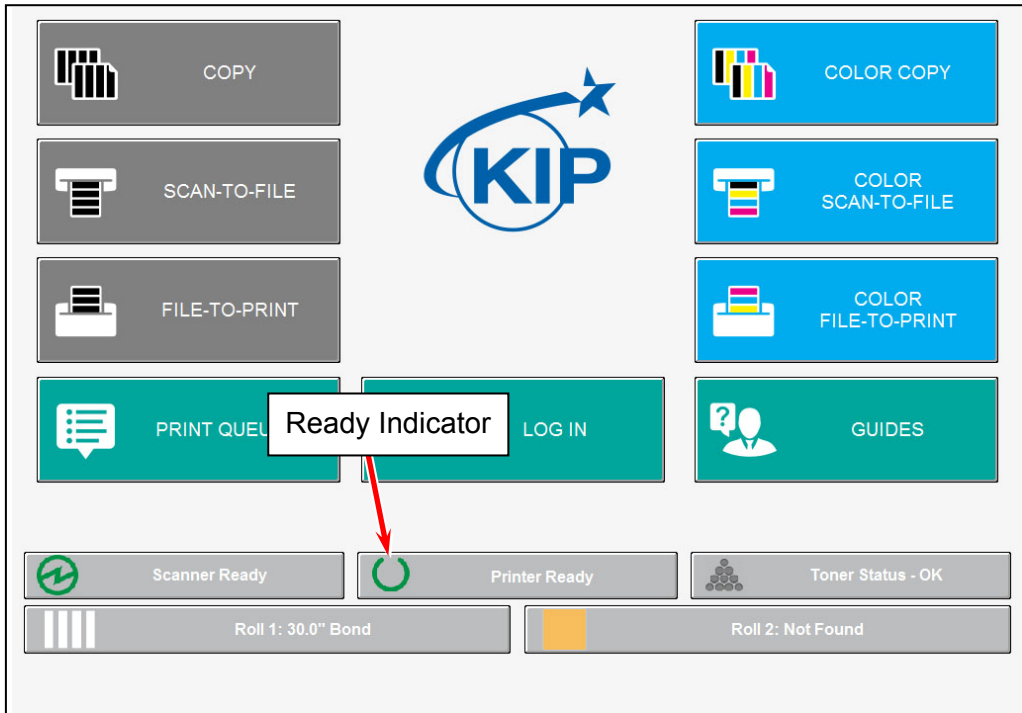

The UI screen may vary depending on your system configuration.
(Shown with available options)

4. When Ready Indicator stops flashing, the KIP 7170 is ready for operation.

NOTE

It is impossible to make any prints while Ready Indicator is flashing in orange. Please wait until it turns in green.



2. 2 Turning off KIP 7170

1. There is a Power Switch on the right side of KIP 7170.
Press its “⏻” side to turn off the KIP 7170.

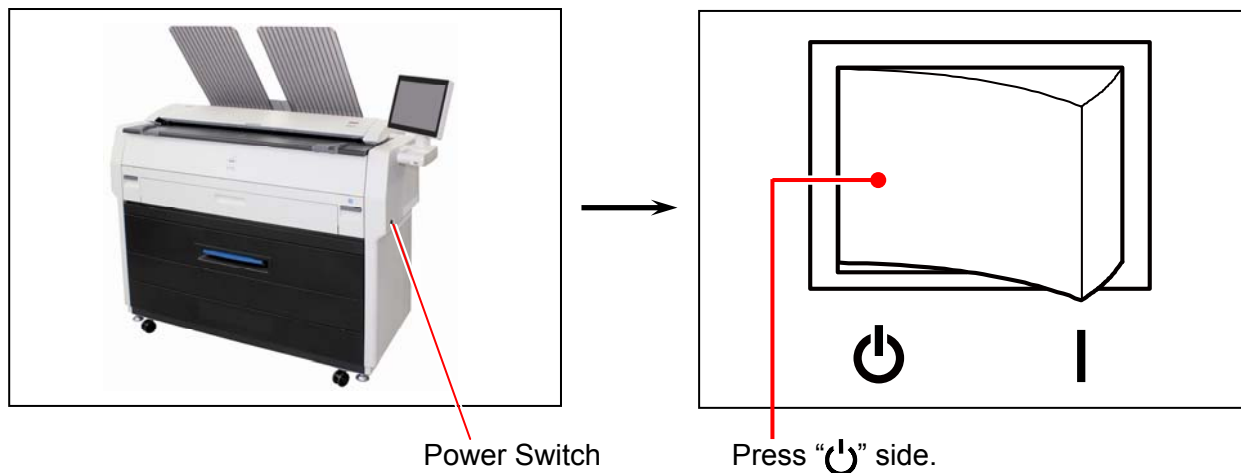

CAUTION

The KIP 7170 print engine and UI appear to be shut down when you turn off KIP 7170. However, the controller PC embedded inside the KIP 7170 is still operating and will shutdown in approximately two minutes after Power Switch operation.

Do not unplug the KIP 7170 before the controller PC completes its shutdown. Doing so may damage data or the device.

2.3 Replacing Roll Media

- (1) When the printer is running out of a roll media, the UI Screen will display “Roll Replacement” sign.
Follow the later procedure (or as noted in the UI’s User Guide) to load a roll media. Please refer to your KS8 Touch Screen Operator’s Guide for the UI screen.
- (2) This section describes how to install a roll media to Roll Deck 1.
The same procedure is applied to Roll Deck 2, unless otherwise noted.

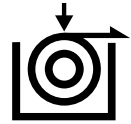

! NOTE

- (1) A paper mis-feed tends to occur just before out of a roll paper.
- (2) A tracing roll paper is recommended to be loaded to Roll Deck 1 (front).

1. Pull the blue lever (1) to unlock the Roll Deck. Draw out the Roll Deck.

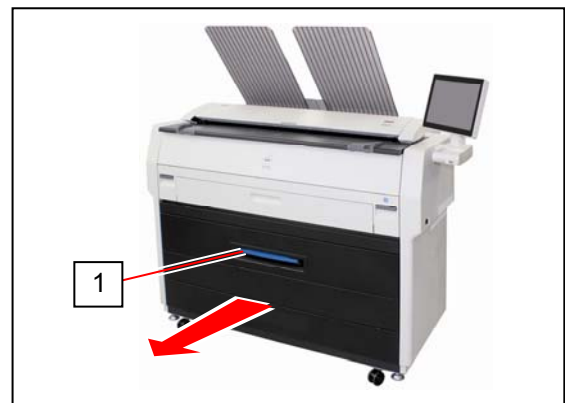

2. Holding both Flanges (2), lift and remove a roll media or an empty roll core (3).

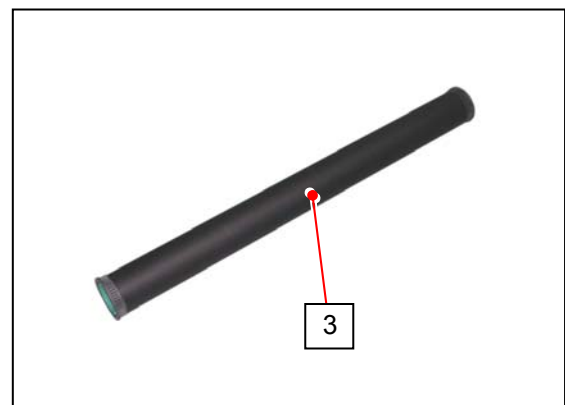
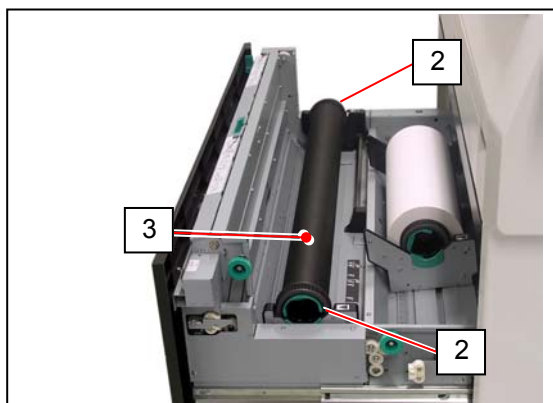

3. Raise the green lever (4) on Flange (2). Remove both Flanges (4) from the roll core (3).

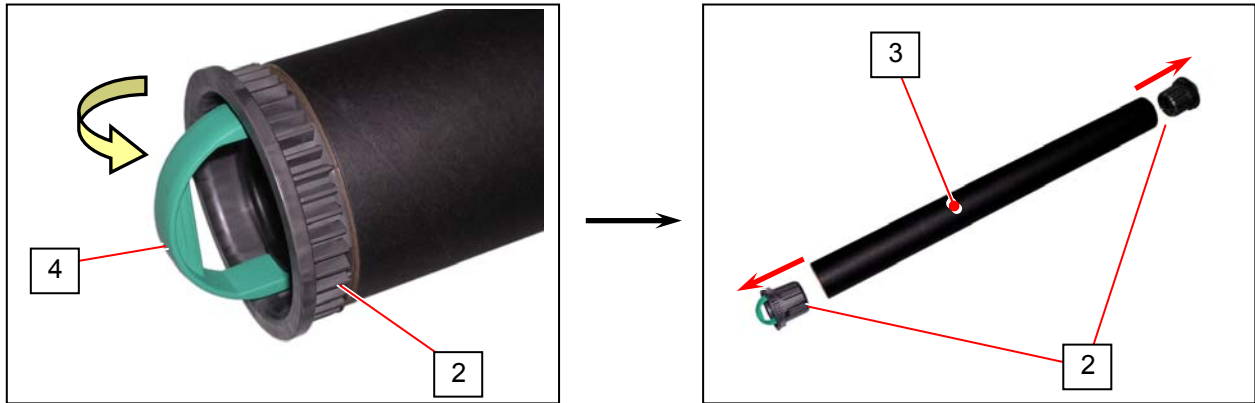

4. Move a right Slide Guide (5) to match your roll media's width. The right and left Side Guides will automatically move together.

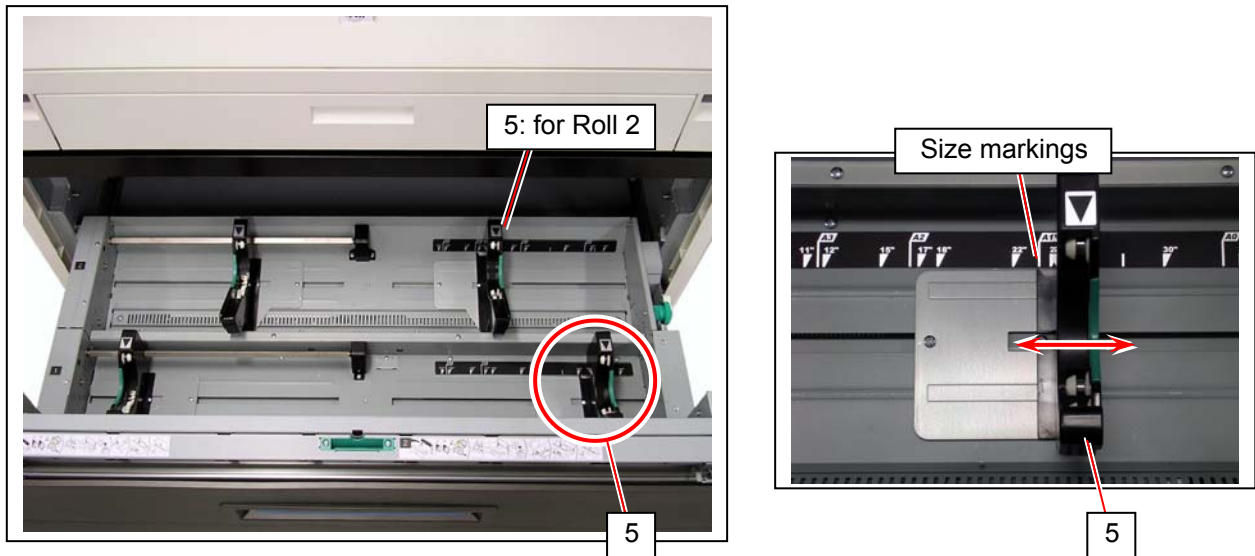

5. Insert each Flange (2) into both ends of the roll media core to be installed.

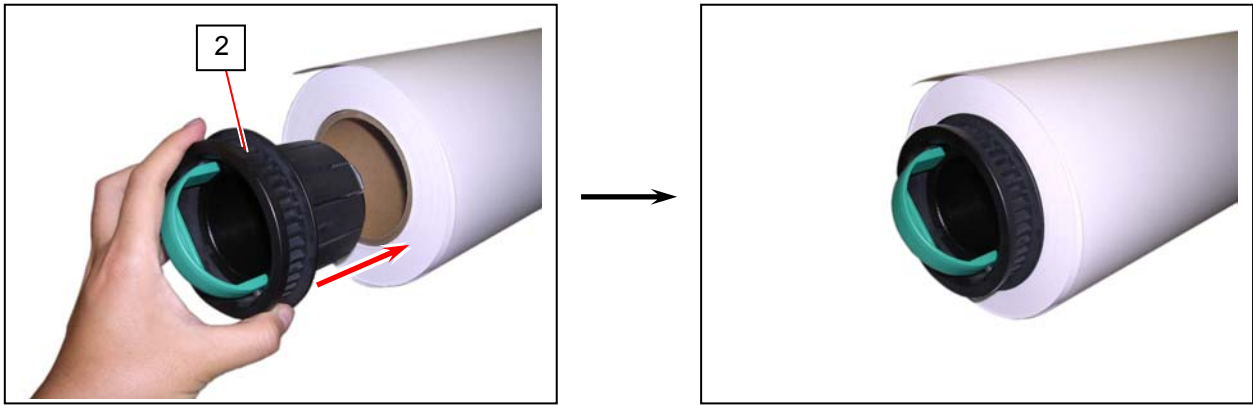

NOTE

(1) Fully insert Flange into the roll media core so that the inside rim of Flange evenly touches the side face of the roll media.



Correct: Fully inserted

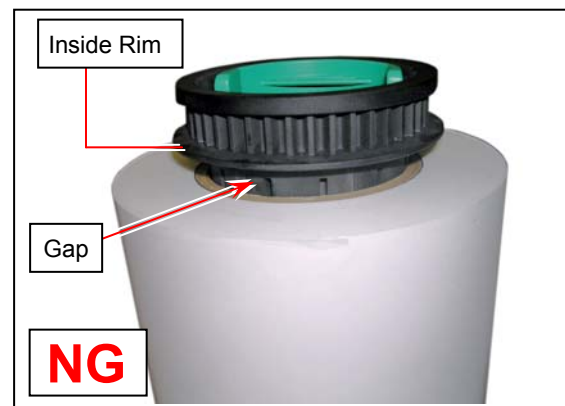

Wrong: not touching roll side

(2) Flange has Stoppers with sharp edge. Be sure not to touch them.

6. Push both the levers (4) down in either way. Position them flat against Flange to secure the roll media.

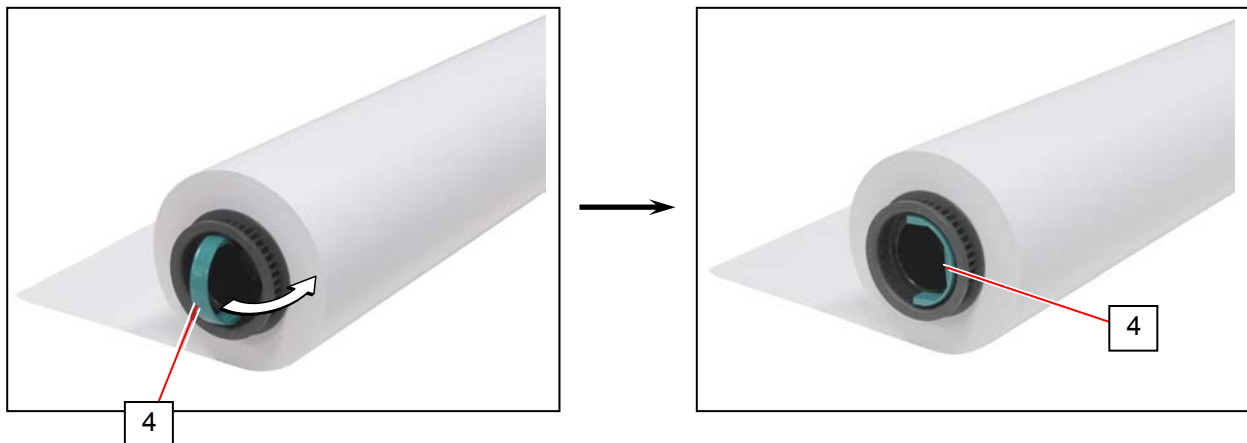

7. Lift the roll media by holding both Flanges. Lower Flanges onto Slide Guides (5) in Roll Deck.

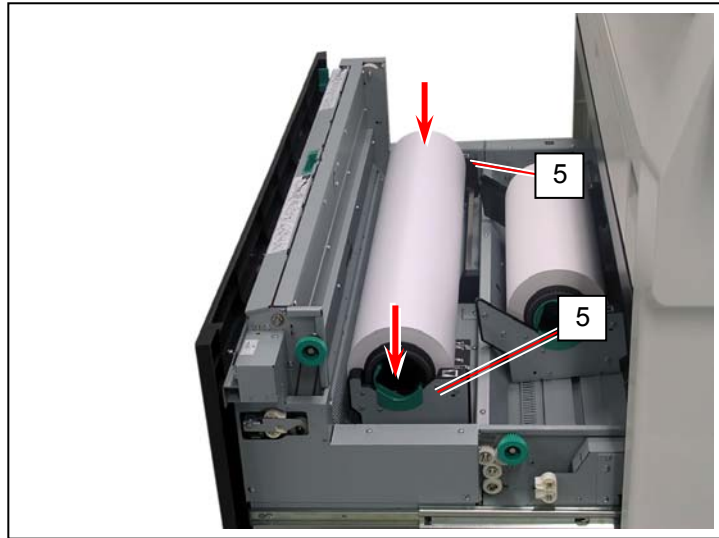

NOTE

(1) Be careful of the winding direction of the roll media.

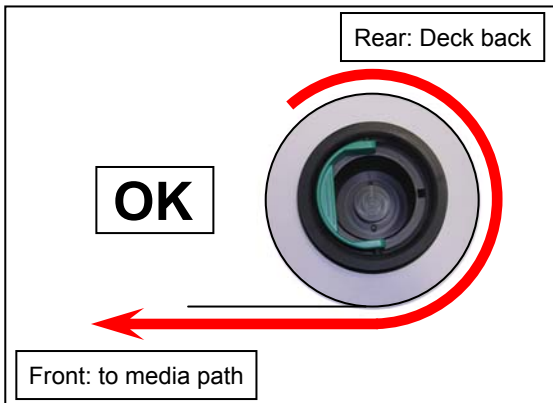

Correct: Edge comes from bottom

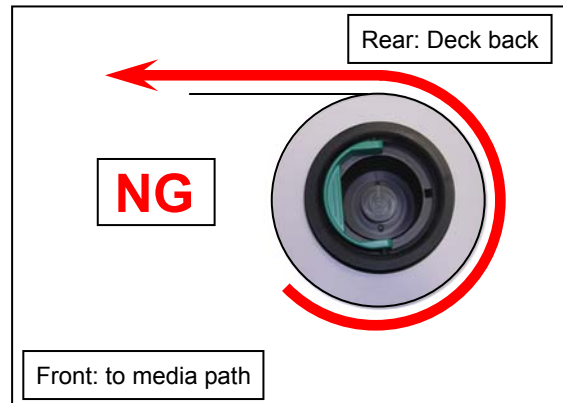

Wrong: Edge comes from top

(2) The outside rim (6) of Flange should meet the black triangle (7) marked on Slide Guide. Otherwise the roll media may fall in Roll Deck or result in an incorrect media feeding.

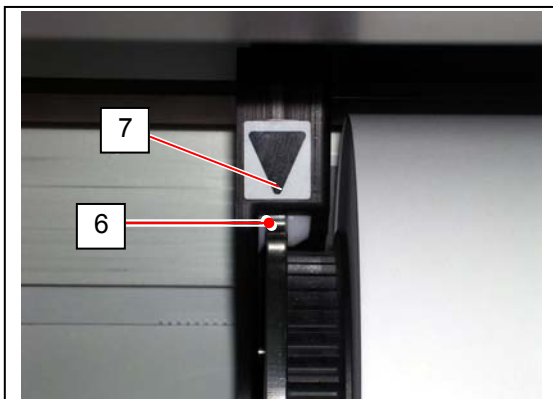

Correct

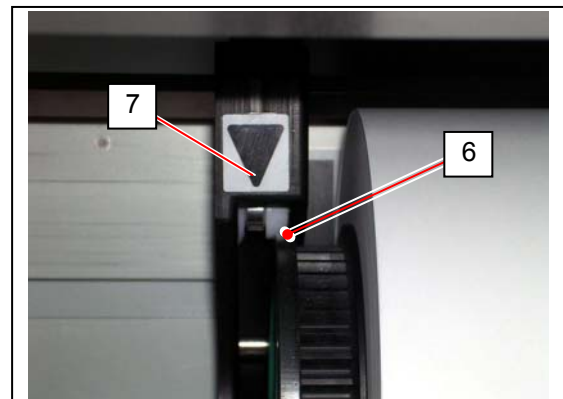

Wrong

8. Insert the leading edge of the roll media under Guide Plate (8) until it touches the feeding roller. Rotate Feed Knob (9) clockwise so that the feeding rollers catch the leading edge.

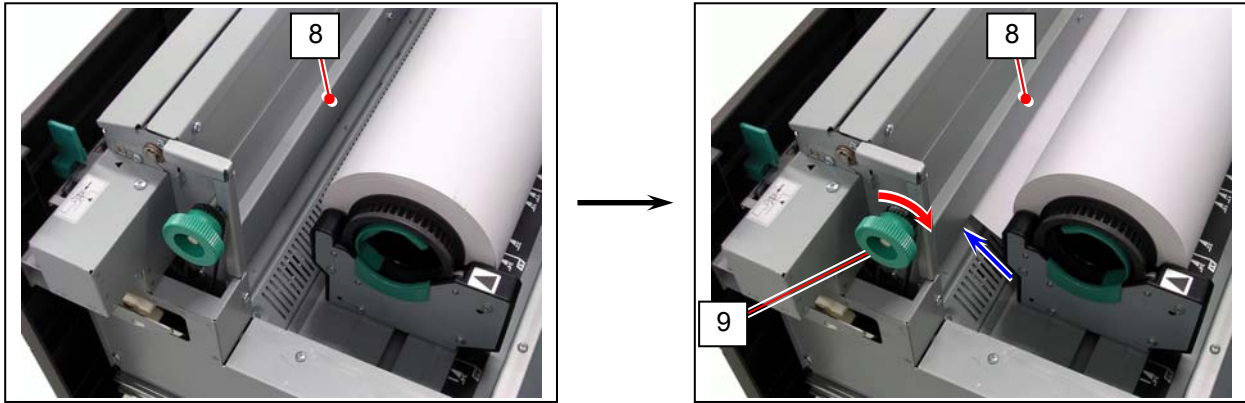

! NOTE

Use the rear Feed Knob (10) for Roll Deck 2.

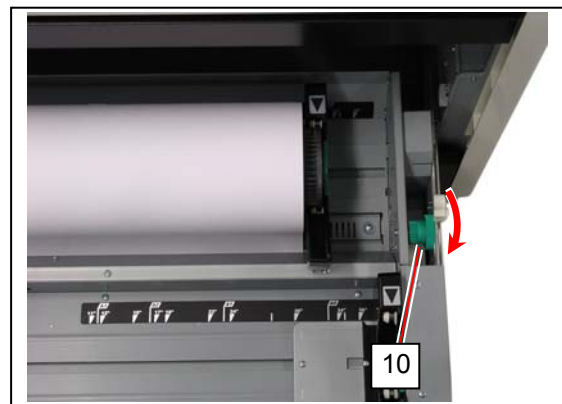

9. Hold the green grip (11: on the middle of Guide Plate) and turn Guide Plate outside. With holding, rotate Feed Knob (9) again so that the leading edge comes out in 100mm.

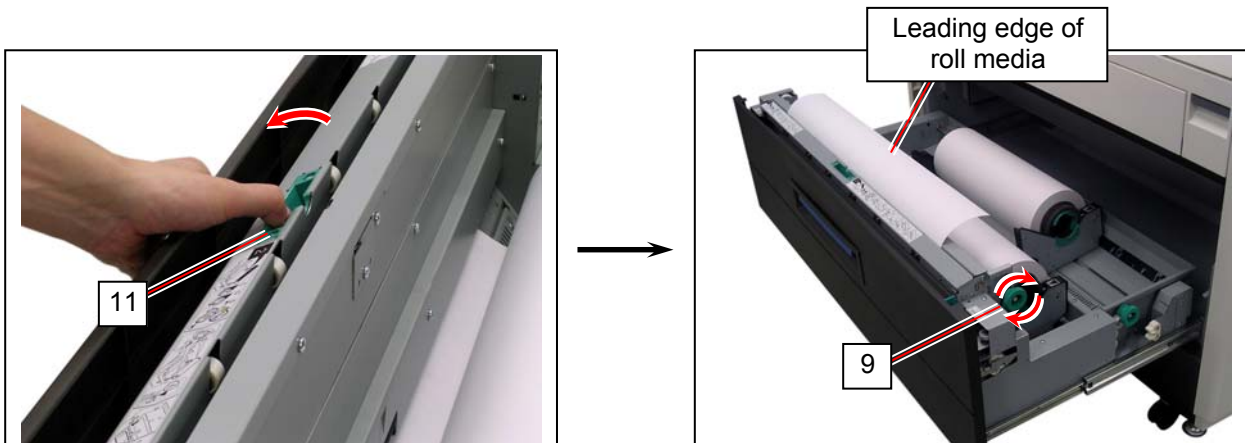

- Slide the green Cutter Knob (12) fully from one side to the other to make a new straight edge. Remove the cut portion.

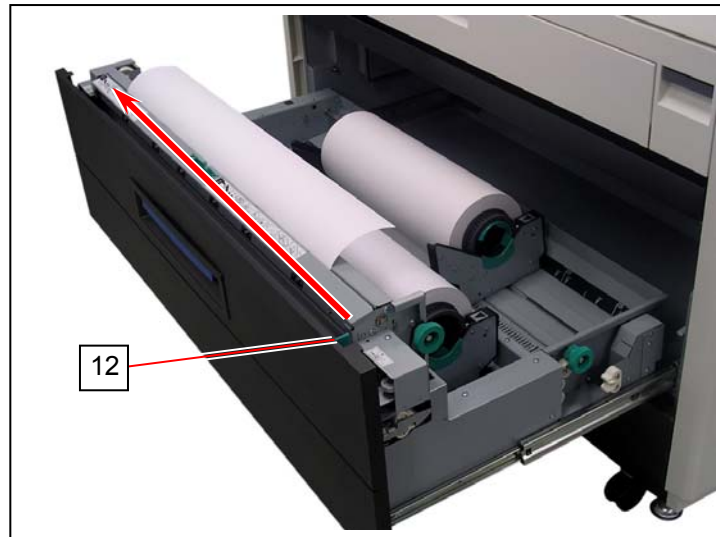

NOTE

Completely slide Cutter Knob (12) until it stops at either end. Not doing so may cause a paper jam.

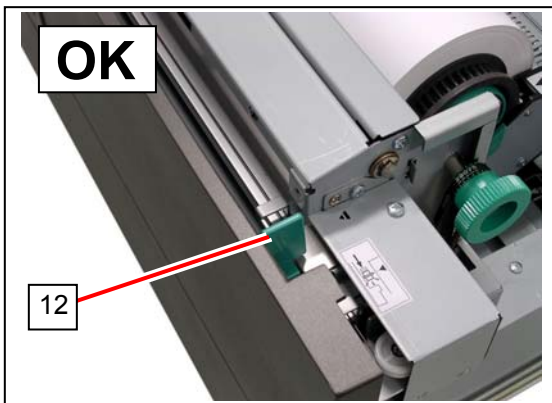

Correct

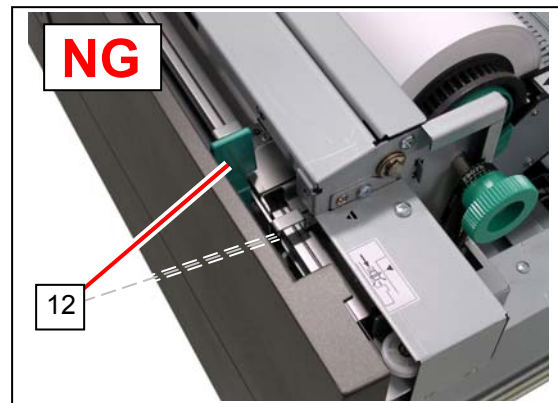

Wrong

- Gently close Roll Deck.

NOTE

Be sure to close the Roll Deck fully until it locks at the correct position. A paper jam may occur if it is not locked firmly.

2. 4 Replacing Toner Cartridge

⚠ WARNING

There is combustible powder in the toner cartridge.
Do not burn up the used toner cartridge.

Reference

When the toner is empty, the UI Screen will display Toner Empty sign.
Follow the later procedure (or as noted in the UI's User Guide) to
replace the Toner Cartridge with a new one (genuine).

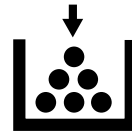

⚠ NOTE

- (1) The KIP 7170 will indicate Toner Empty sign if an incorrect toner cartridge or no toner cartridge is installed to the printer.
- (2) At the machine's installation, some amount of initial toner powders will be supplied to the machine. Thus Toner Empty sign might appear slightly earlier for the first installed toner cartridge than usual.

1. Open the Toner Hatch (1).

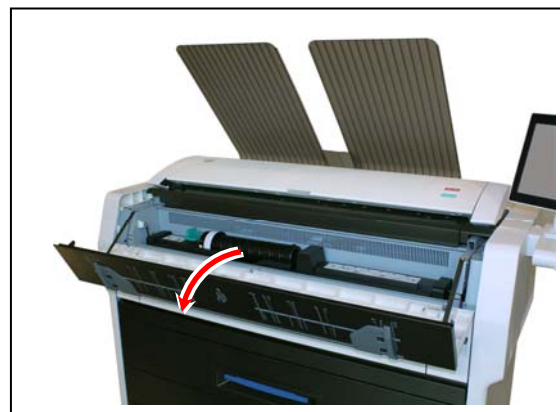
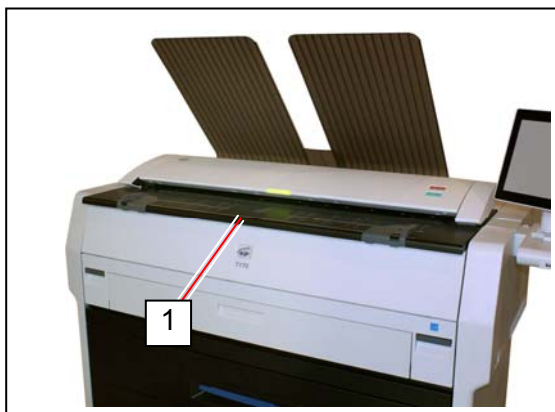

- Slide the green Lever (2) to the right to unlock the Toner Cartridge.
(Lever (2) is held automatically.)

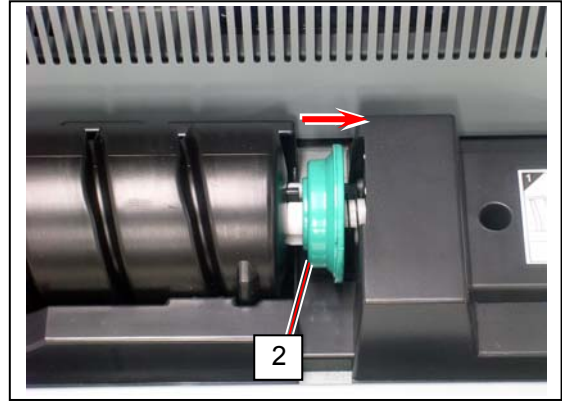
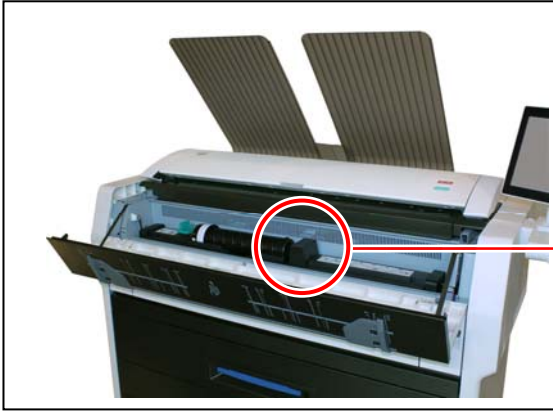

⚠ NOTE

Be sure to unlock the Toner Cartridge by releasing the green Lever (2).

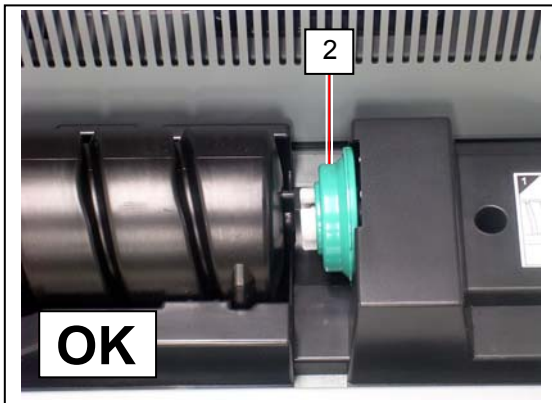

Correct: disengaged
(The green Lever (2) is shifted to the right.)

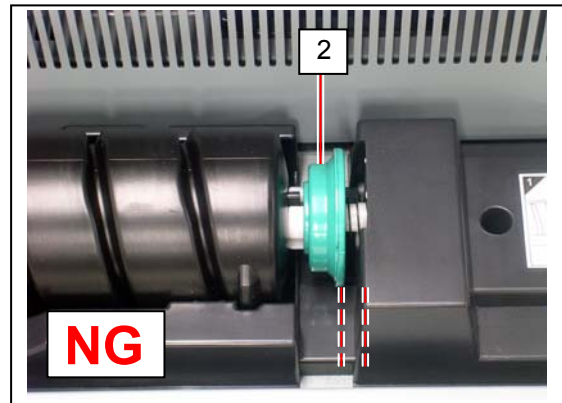

Wrong: not disengaged

3. Pressing down the Cartridge Lock Lever (3), turn the body (4) of cartridge to the arrow direction until it stops.
(You can close the toner supply hole of the cartridge firmly by this)

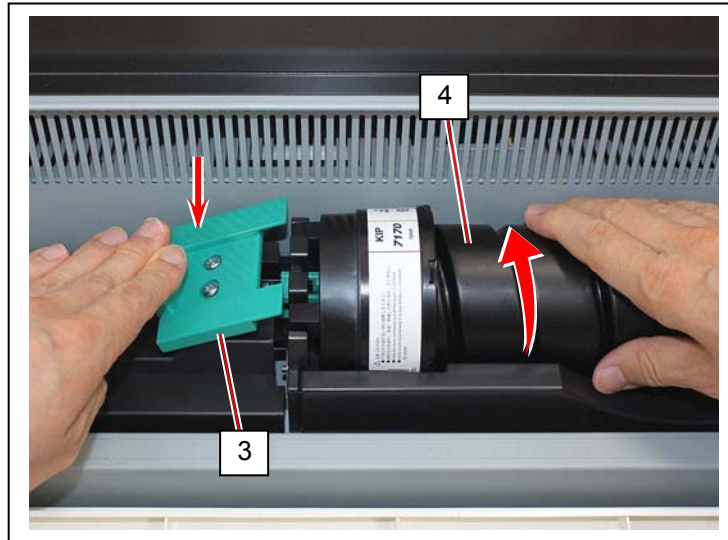

! NOTE

The toner may drop from the toner supply hole, and it may scattered into the machine or on the floor if you remove the Toner Cartridge without closing the toner supply hole (5).



4. Pressing down the Cartridge Lock Lever (3), bring up the left side of the Toner Cartridge first, and then remove the whole cartridge from the machine.

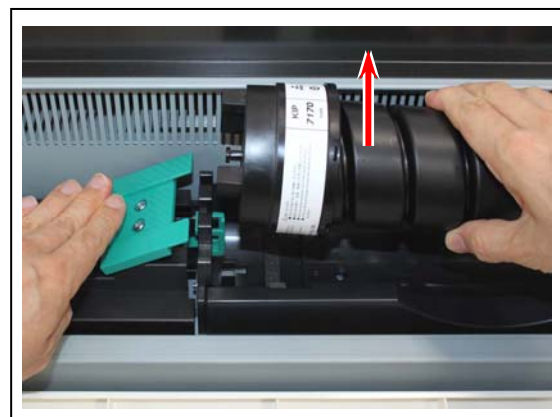
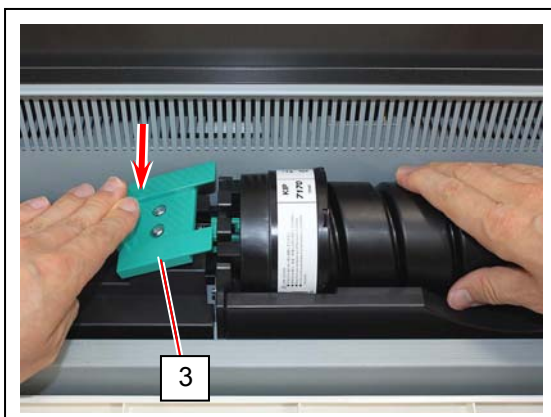

5. Shake the new Toner Cartridge left and right 5 times or more to make the toner smooth. After shaking, tilt the Toner Cartridge to the cap side.



6. Keep pressing down the Cartridge Lock Lever (3). Direct the toner supply hole to the floor, fit the pin (6) on the left side of the cartridge to the groove (7) on the machine side.

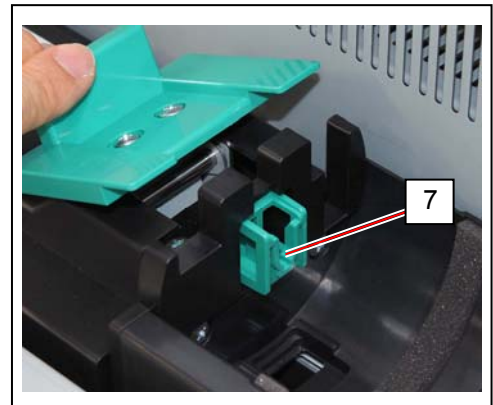
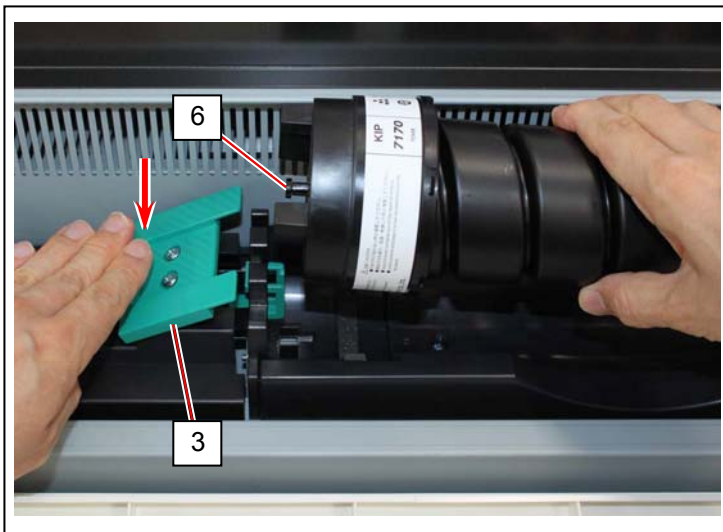

⚠ NOTE

Please confirm that the Cartridge Lock Lever (3) firmly locks the Toner Cartridge at the correct position. (It must be at a level position.)

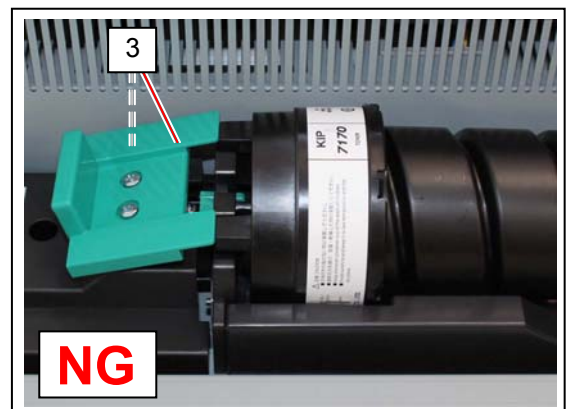
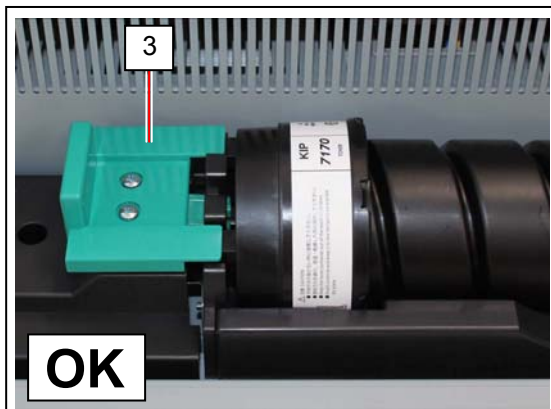

7. Turn the body (4) of the cartridge in one revolution to the arrow direction to open the toner supply hole. Confirm that the projection (8) is fitted into the notch (9).

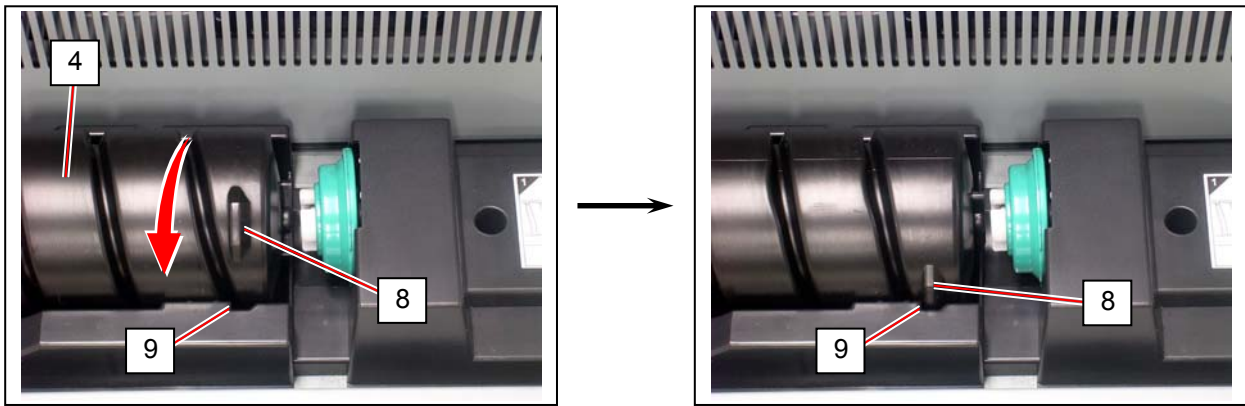

! NOTE

It is not necessary to lock the cartridge with the Lever (2). Lever (2) will engage on its own after closing the Toner Hatch.

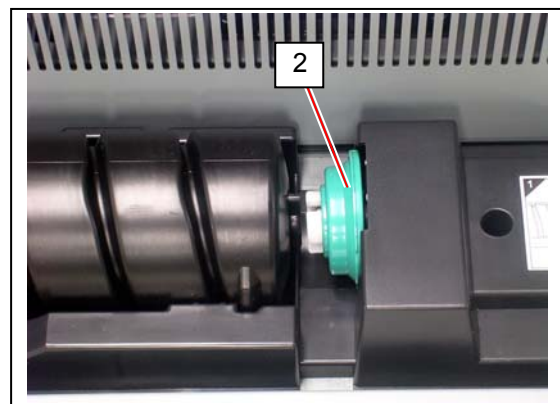

8. Close the Toner Hatch (1).

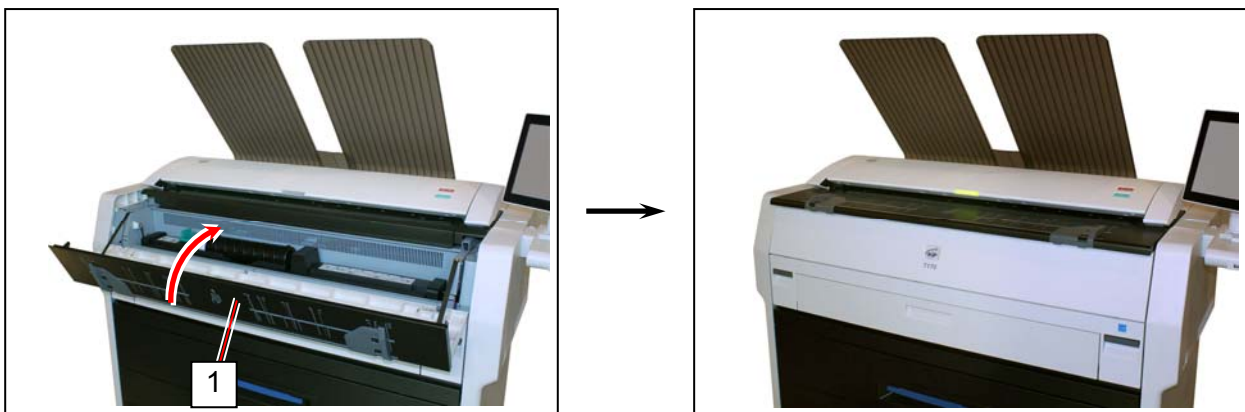

2.5 Cut Sheet Media

1. Open the Bypass Feeder (1).

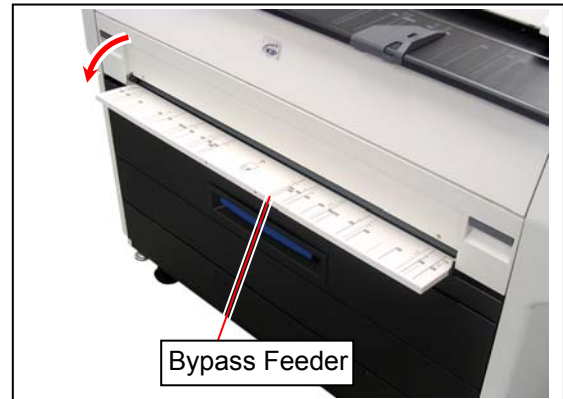

2. There are several size markings on the table of Bypass Feeder which indicate possible feed positions. Place the cut sheet paper on the table between its concerning size markings then insert it into the Bypass Feeder. When the leading edge touches the feeding roller, the machine automatically carries and sets the paper at the proper position.

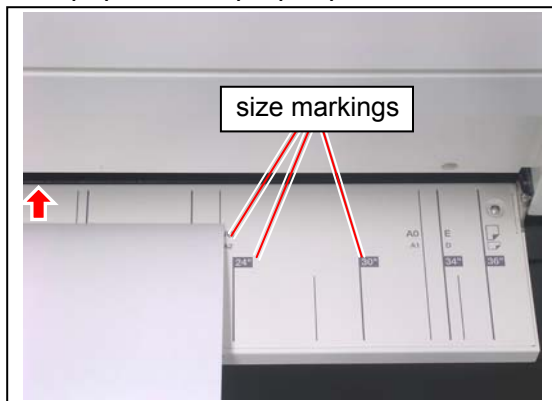

! NOTE

- (1) As a curly cut sheet will cause a mis-feed, straighten the sheet as far as possible before printing. And set the sheet in "curl down" direction as a mis-feed can be avoided. "Curl up" sheets tend to result in a mis-feed.



Correct (curl down)

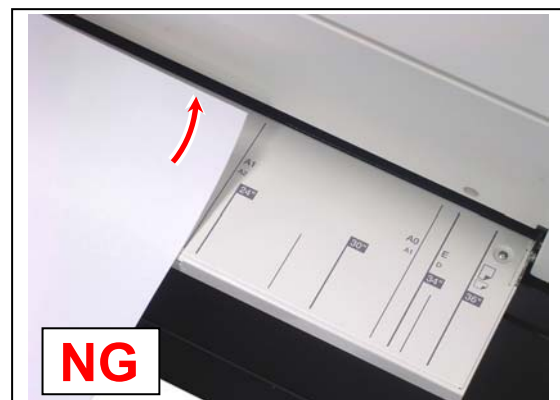

Incorrect (curl up)

- (2) Setting a cut sheet to the Bypass Feeder while the printer is processing a print job cause a paper jam.

2.6 Copying

1. There are several size markings on Original Table which indicate possible feed positions. Line up Original Guides with the proper markings according to the original width.

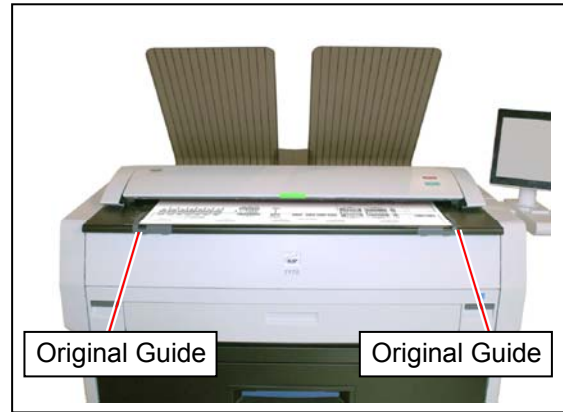

2. Place the original on the Original Table with face up. Then insert it under the Scanner Unit along with Original Guides. When the leading edge touches the original feeding roller, the machine automatically carries and sets the original at the proper position. When the original is at wait position, the LED Indicator will turn off.

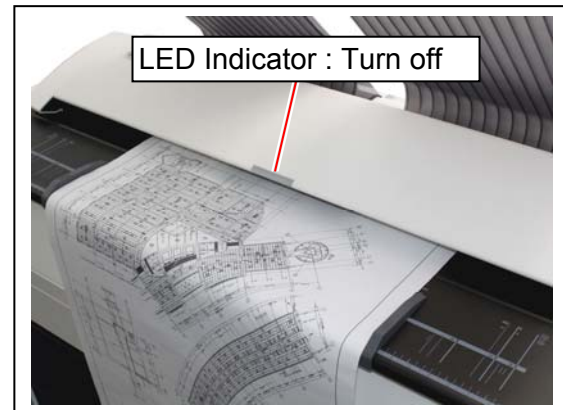
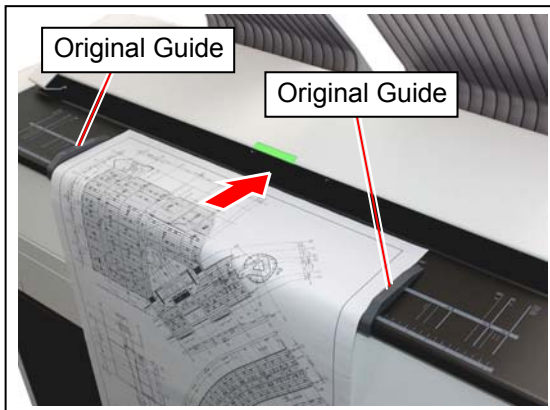

3. The KIP 7170 will start the copy process.

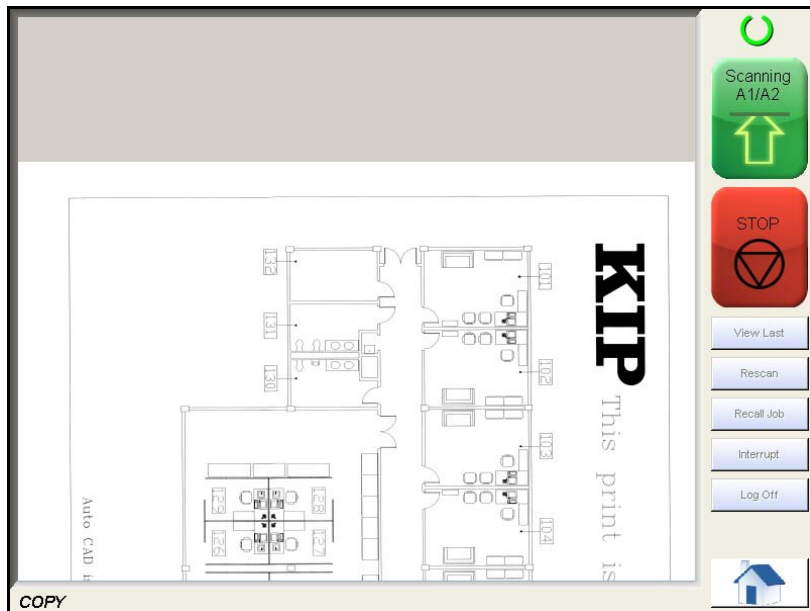

Reference

Pressing START button may be required to start the scan according to the scanner's controller software. For further details of "Auto Start", see the software's document.

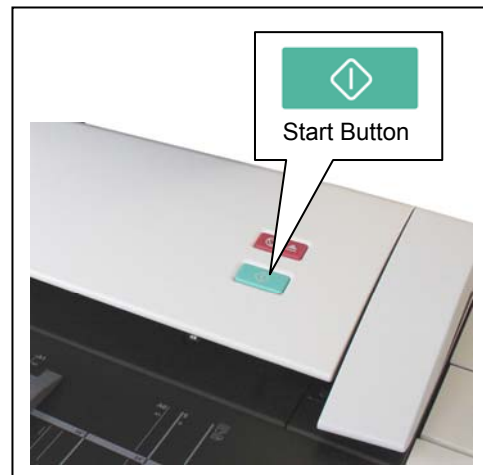

NOTE

The scanner unit does not accept originals automatically during Sleep Mode. Tap on the UI screen and then insert an original.

The KIP 7170 has 2 print delivery system, the print tray (front, standard) / rear stacking equipment (back, option).



NOTE

For the front stacking, gently lift up the prints on the print tray to the arrow direction to avoid rubbing the print surface. A large number of prints should be removed in several sheets.

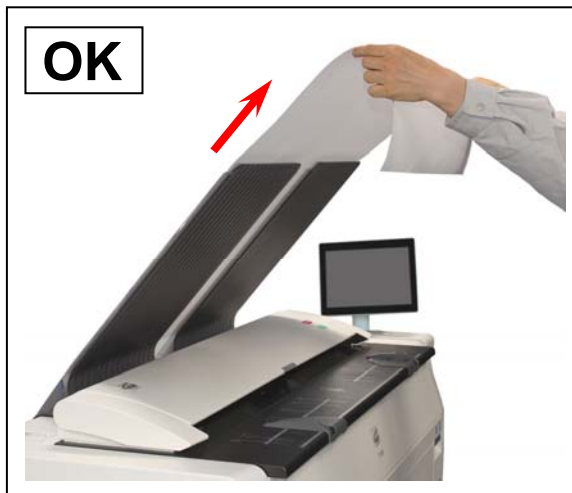

Correct: Gently lift up and remove



Wrong: Do not pull downward

For the front stacking, the printer will inform you of “Upper Bin Full” on exceeding capacity of stacking. If the UI screen shows “Upper Bin Full”, remove all the prints on the print tray.

For further information of switching front / back delivery, see KS8 Touch screen Operator’s Guide.

2. 7 Stop of Scan or Copy

1. If necessary, press the Scan Abort Button on the Scanner Unit to immediately stop the original while making a copy or scan. The LED Indicator flashes red.

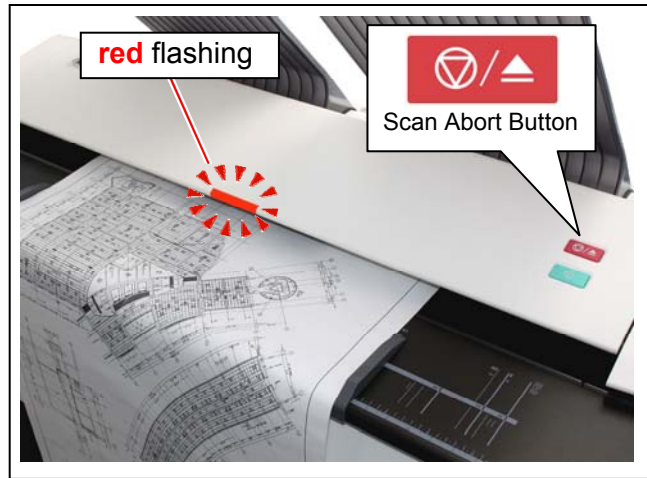

Pressing the button stops the current reading a document immediately. The current printing is stopped as well and is ejected.

NOTE

Do not pull back or hold down the original on Original Table as an attempt to stop feeding it through Scanner Unit.

2. 8 Canceling Sleep Mode

The KIP 7170 has two Sleep Modes to reduce the power consumption. The KIP 7170 will enter Sleep Mode after a certain period of inactivity.

In the default setting;

- Warm Sleep Mode will start after a 15 minute of inactivity in order to reduce the power supply for Fuser Unit.
- Cold Sleep Mode will start after a 60 minute of inactivity to stop the power supply for Fuser Unit and some other components.

Sleep Mode is canceled and the machine gets ready when;

- the machine receives a print job through the network.
- you tap on the UI screen then an original is inserted the scanner unit.



NOTE

(1) It may take time for the machine to get ready.

(2) Tapping on the UI screen can cancel the screensaver but the KIP 7170 needs to recover temperature on Fuser Unit.
It may need another waiting time to start warming up for printing.

(3) Recommended Default Delay Times: 60min

2.9 Dehumidifying Roll Media

If the roll paper is extremely humidified, it may cause several kinds of defective print. Defective prints you will experience most will be “crease of paper” and “loss of image”.

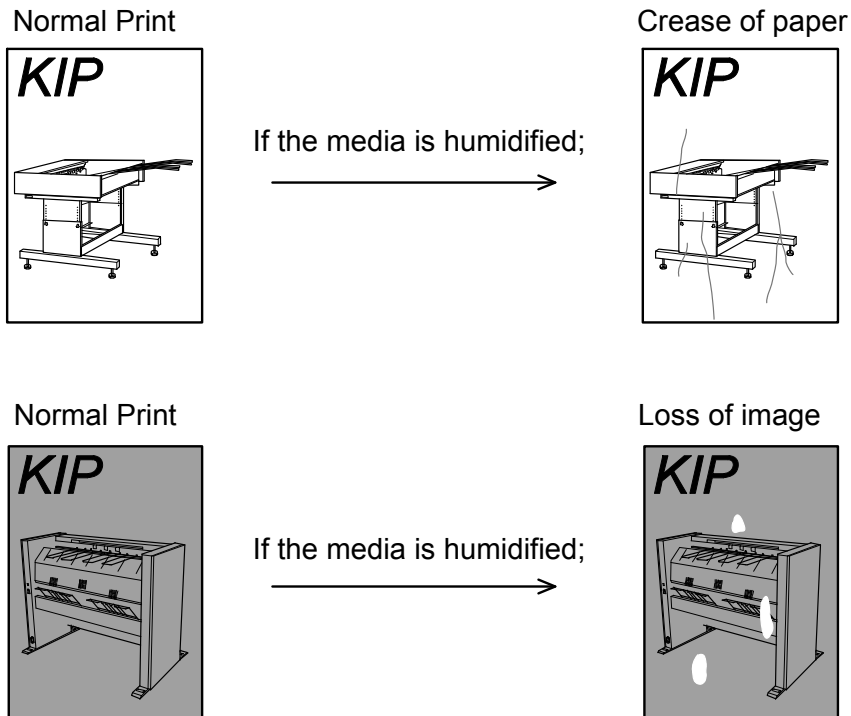

If the KIP 7170 is installed in such a condition, it is recommended to use the optional embedded “Dehumidify Heater”.

Turn on the Dehumidify Heater if the room air has too much humidity (75% or higher) to prevent the above kinds of print defect. Such problems above may be resolved.

NOTE

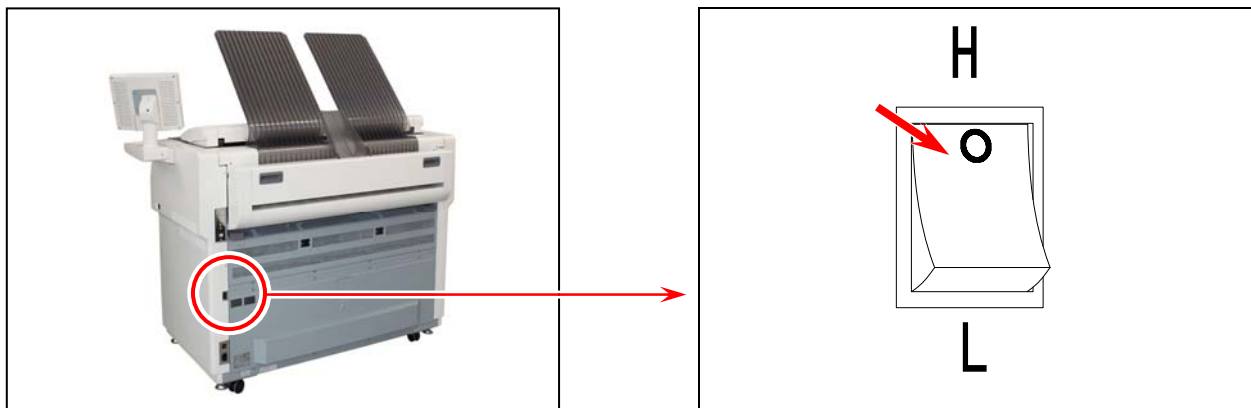

KIP 7170 is equipped with the Dehumidify Heater (optional for the US)
If needed, contact the service personnel for detail.

To turn on the Dehumidify Heater, press the H side of the Dehumidify Heater Switch on the rear.
(Press its L side to turn off.)



Chapter 3

Error Correction

3.1 Mis-feed Error	Page
3.1.1 Deck Jam / Feeding Jam	3- 2
3.1.2 Manual Jam	3- 5
3.1.3 Reg. Jam / Internal Jam	3- 6
3.1.4 Fuser Jam	3- 7
3.1.5 Stack Jam	3-10
3.1.6 Original Jam	3-11
3.1.7 Accessory Jam	3-11
3.2 Other Operator Call Error	3-12
3.2.1 Roll Replacement 	3-12
3.2.2 Toner Empty 	3-12
3.2.3 Cutter Set NG	3-12
3.2.4 Scanner Unit Open	3-12
3.2.5 Printer Not Available	3-12
3.3 Service Call Error	3-13

3. 1 Mis-feed Error

⚠ NOTE

- (1) Be careful not to get paper cuts on your hand.
- (2) It is recommended to take off your ring, bracelet or watch when removing a mis-feed media.
- (3) Gently remove a jammed paper. When it does not reach Fuser Unit, toner on it may spill off. If toner gets into eyes or your mouth, immediately rinse them with water and contact a doctor.
- (4) Gently remove a jammed paper. When it does not reach Fuser Unit, toner on it may spill off on your cloth. Dust off your cloth. Use cold water to wash in out. Using hot water may leave a stain.

3. 1. 1 Deck Jam / Feeding Jam

Either of “Deck is jam” or “Feeding Jam” will be indicated when the roll paper is mis-fed in the Roll Deck.

1. Pull the blue lever (1) to unlock the Roll Deck. Draw out the Roll Deck.

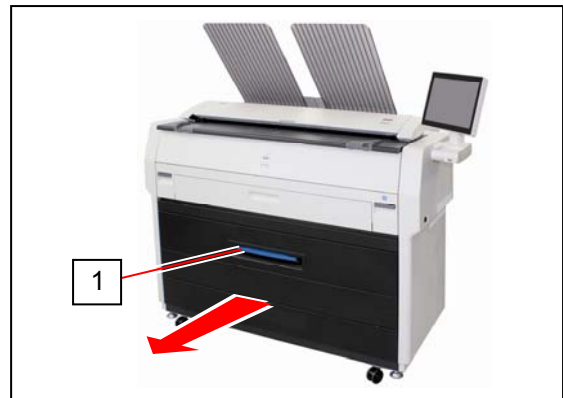

2. Rewind the roll media.

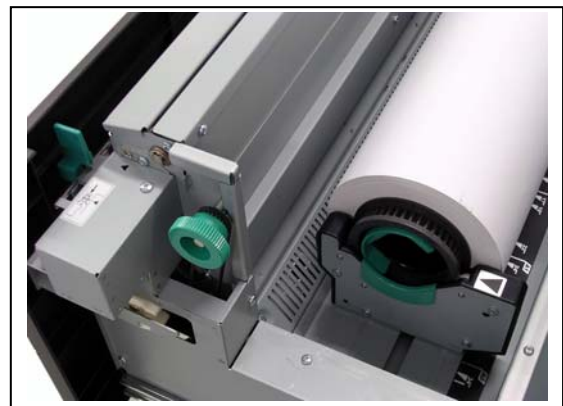
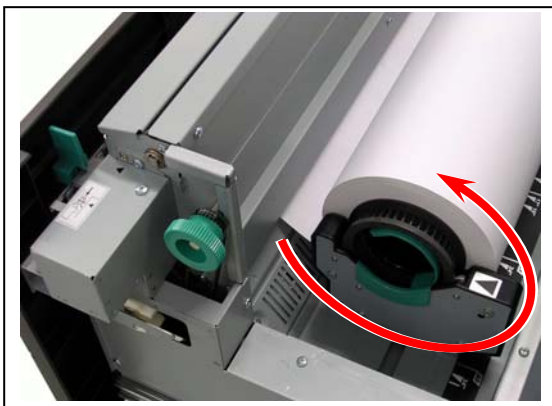

3. Insert the leading edge of the roll media under Guide Plate (2) until it touches the feeding roller. Rotate Feed Knob (3) clockwise so that the feeding rollers catch the leading edge.

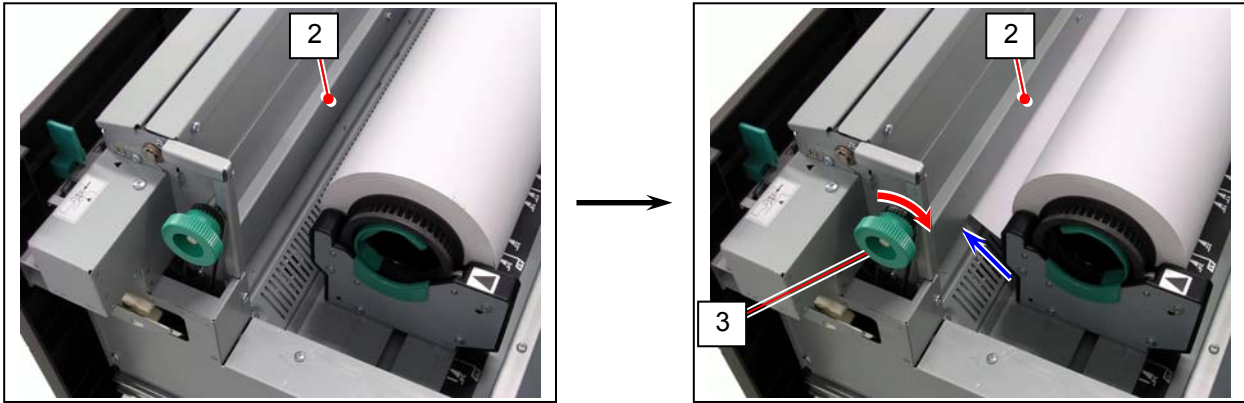

! NOTE

- (1) The leading edge should be trimmed with a cutter in case of an extreme crease.
- (2) Use the rear Feed Knob (4) for Roll Deck 2.

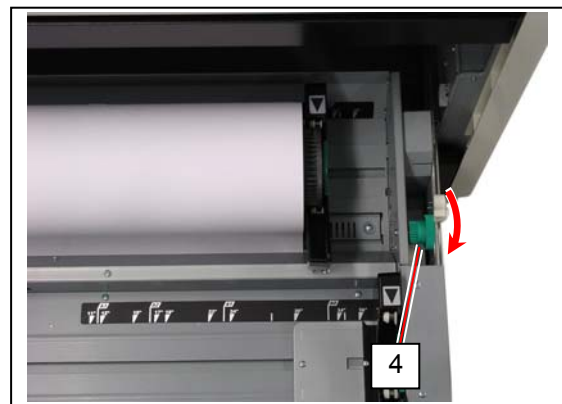

4. Hold the green grip (5: on the middle of Guide Plate) and turn Guide Plate outside. With holding, rotate Feed Knob (3) again so that the leading edge comes out in 100mm.

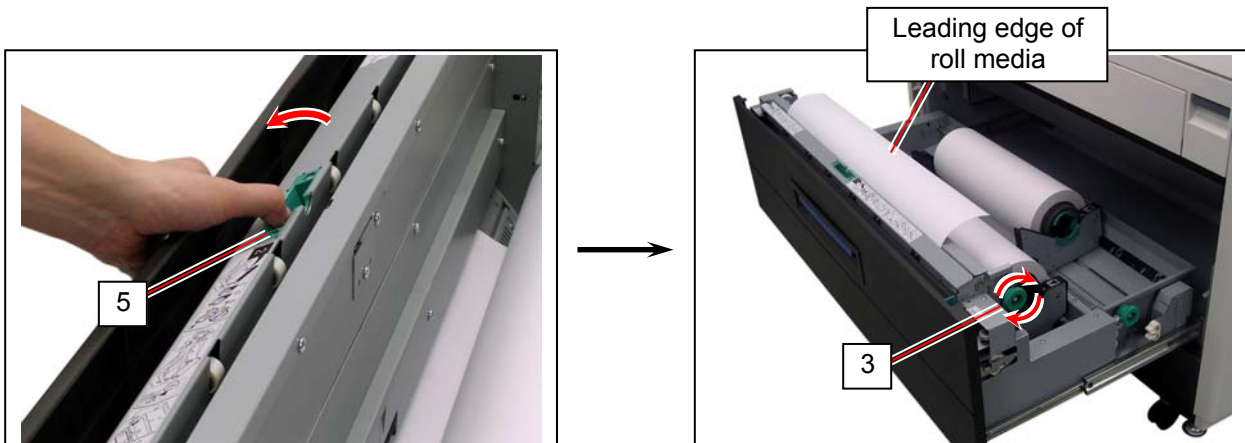

- Slide the green Cutter Knob (6) fully from one side to the other to make a new straight edge. Remove the cut portion.

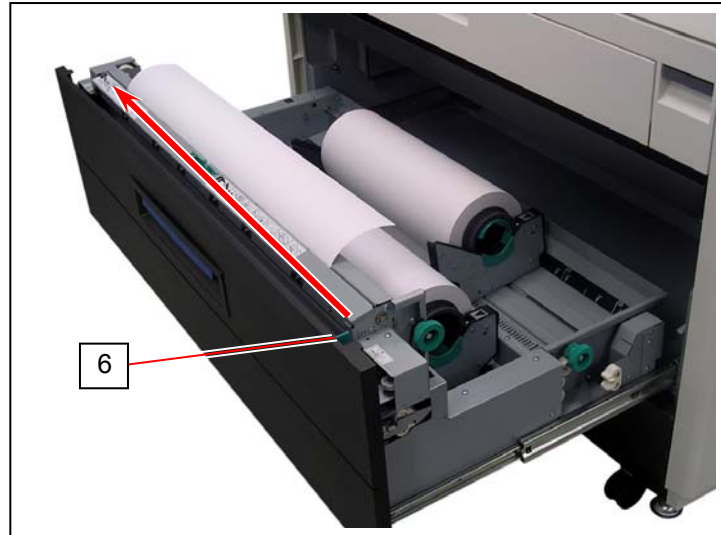

! NOTE

Completely slide Cutter Knob (6) until it stops at either end. Not doing so may cause a paper jam.

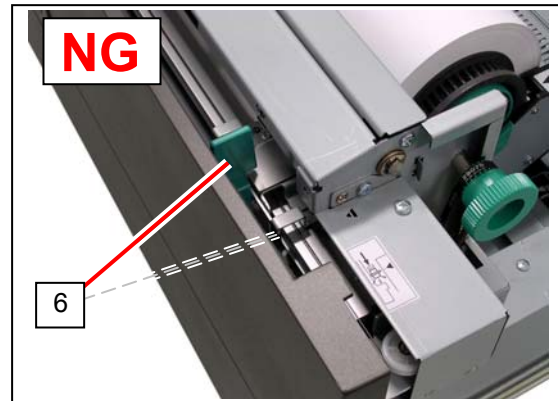
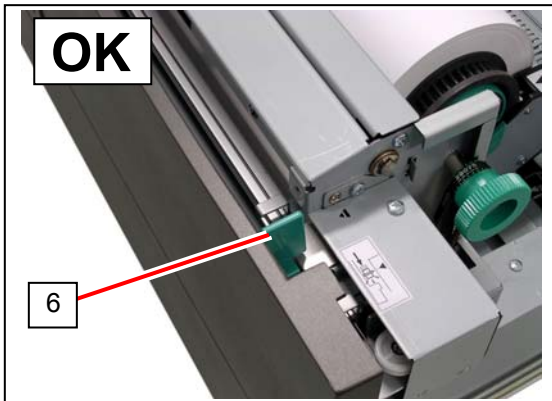

- Gently close Roll Deck.

! NOTE

Be sure to close the Roll Deck fully until it locks at the correct position. A paper jam may occur if it is not locked firmly.

3. 1. 2 Manual Jam

1. Remove all Print Trays (1).

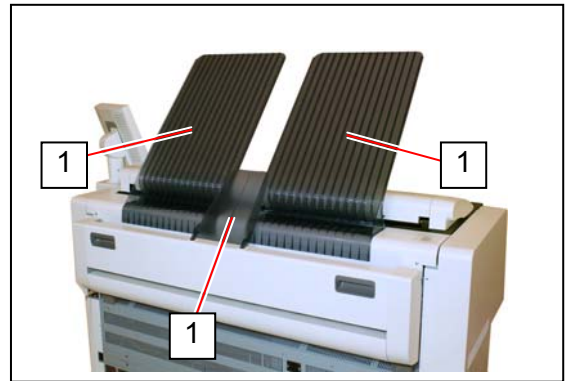

2. Pull up the Engine Unit Open Levers (2) to open the Engine Unit.



3. Remove the mis-fed paper pulling forward.



4. Gently close the Engine Unit.

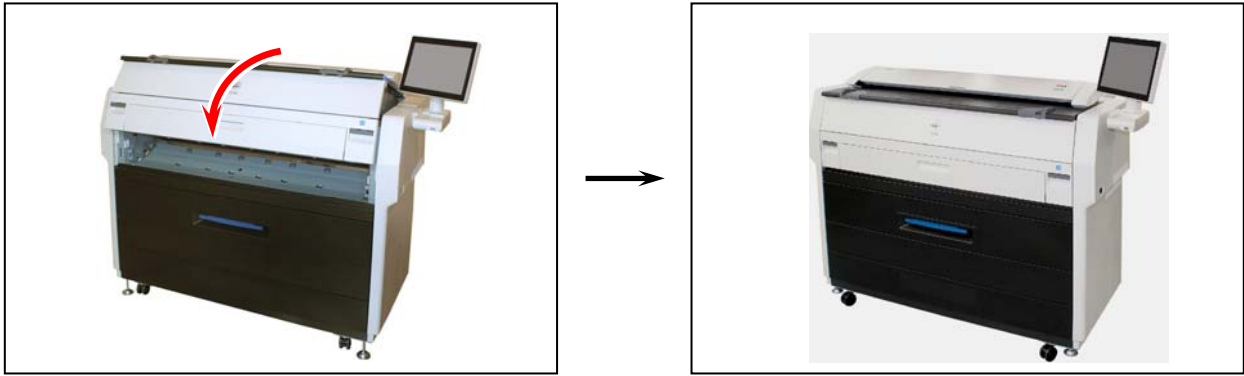

⚠ NOTE

- (1) Be sure to close the Engine Unit firmly until it locks at the correct position.
- (2) The mis-feed cut sheet should be replaced with a new one if its leading edge has a torn or fold. Or it should be used upside down to keep the damaged edge from been inserted. An extremely creased cut sheet may cause mis-feed again.

5. Replace Print Trays in the original position.

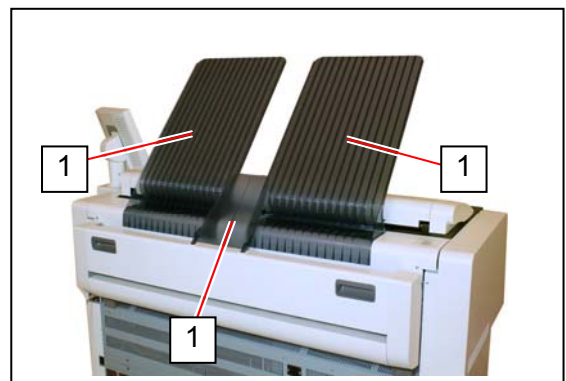

3. 1. 3 Reg. Jam / Internal Jam

1. Remove all Print Trays (1).

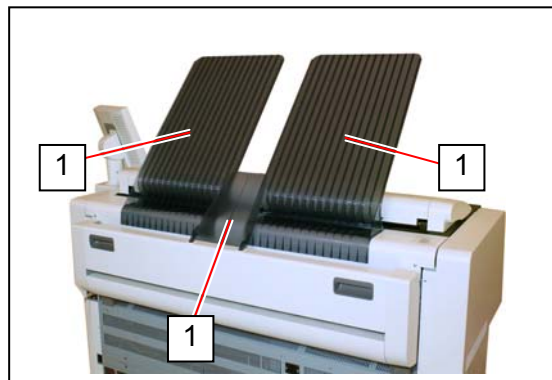

2. Pull up the Engine Unit Open Levers (2) to open the Engine Unit.

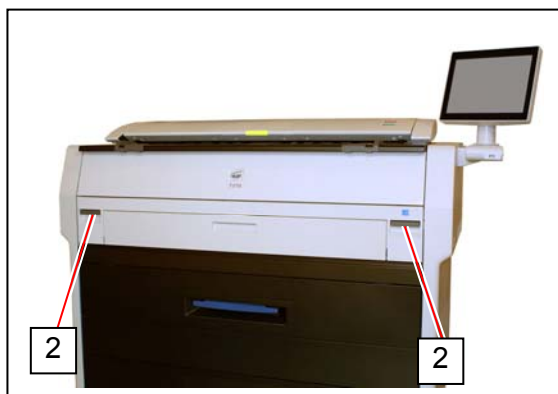

3. Remove the mis-fed paper.

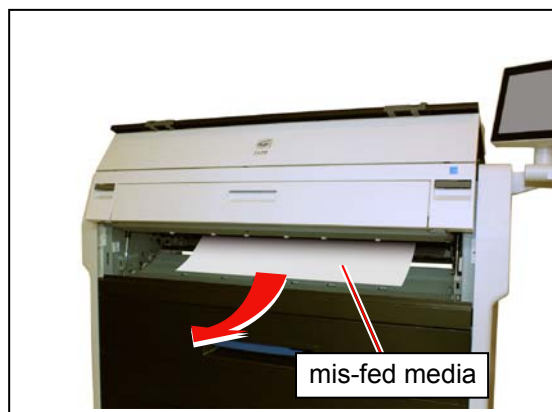

4. Gently close the Engine Unit.



! NOTE

Be sure to close the Engine Unit firmly until it locks at the correct position.

5. Replace Print Trays in the original position.

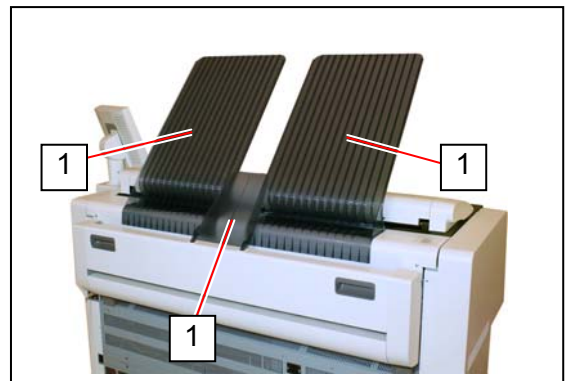

3. 1. 4 Fuser Jam

1. Remove all Print Trays (1).

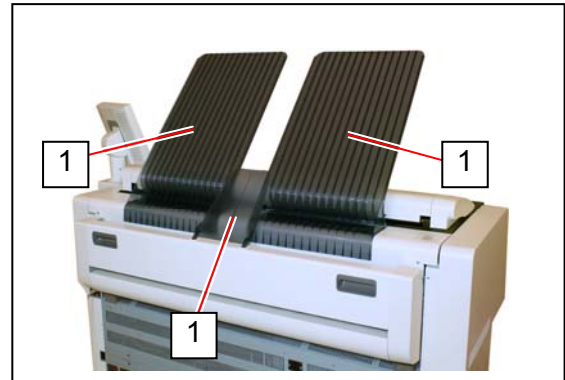

2. Pull up the Engine Unit Open Levers (2) to open the Engine Unit.

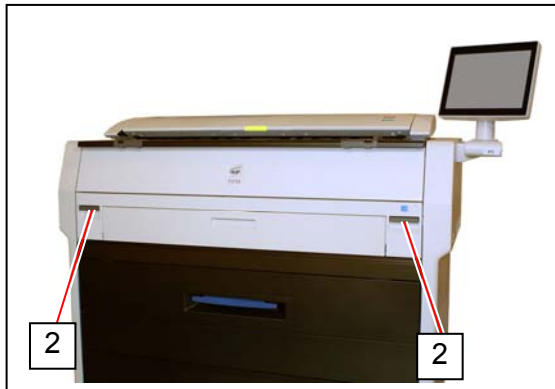

3. Remove the mis-fed paper.

If the mis-fed paper cannot be seen or removed, leave the media and go to the next step.

If the paper (including any torn part) can be removed, go to step 8.

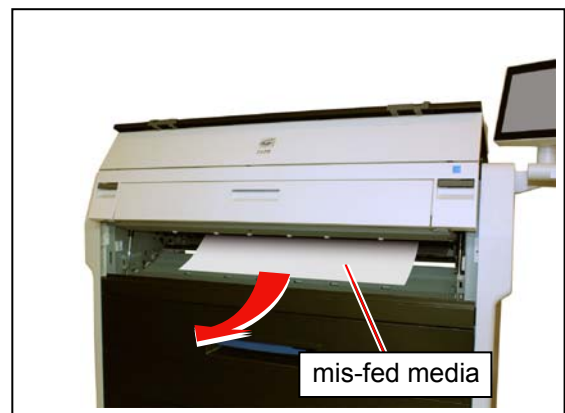

4. Hold the gray handles and open the Exit Cover (3).

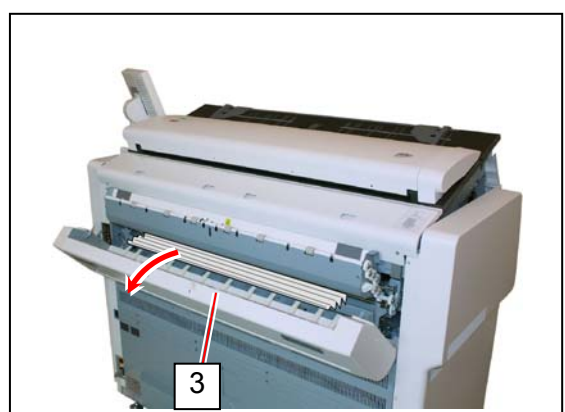
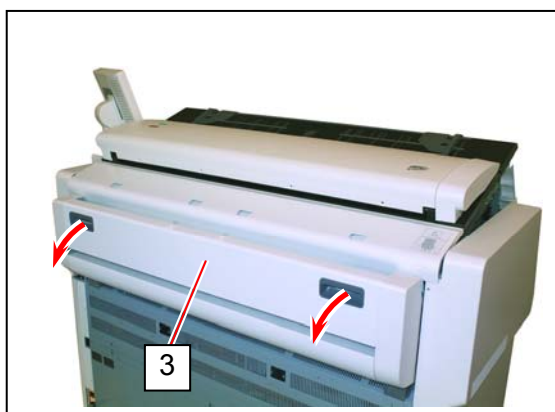

5. Pull and remove the jammed print to the rear.

If you remove the print at this time, just close the Exit Cover.
If the print cannot be removed, go to the next step.

If the print (including any torn part) can be removed, go to step 8.

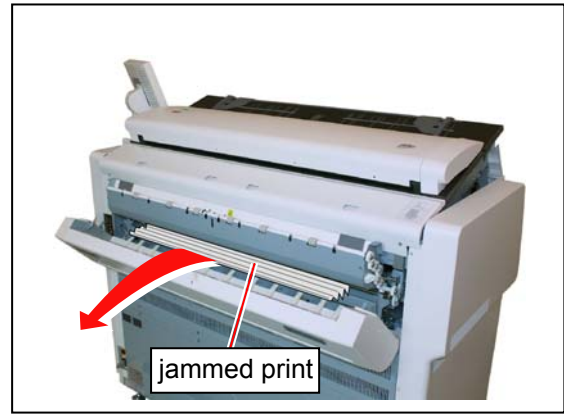

! NOTE

If removed a mis-fed paper inside the Exit Cover, scattered toner can be adhered to the next print.

6. Hold the gray areas (4) and release the Fuser Door (5).
Pull and remove the jammed print to the rear.

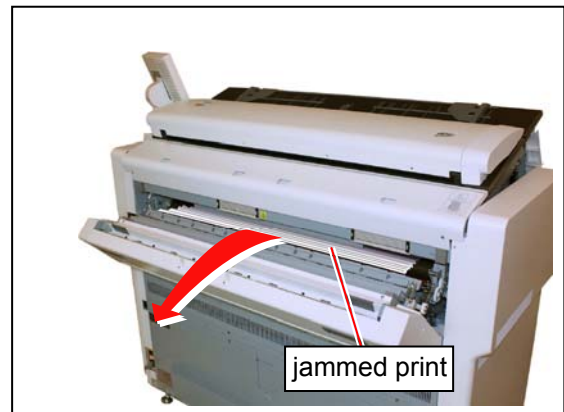
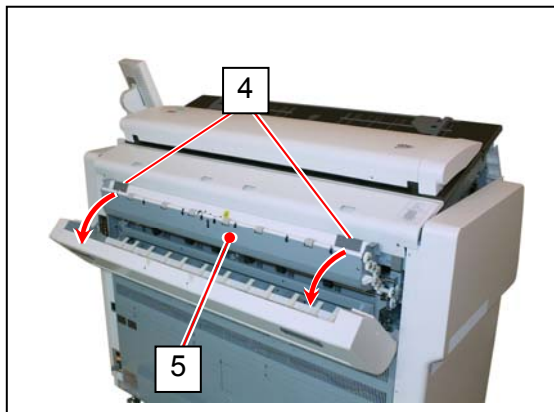

! WARNING

There are extremely hot parts inside the Fuser Door.
Do not touch any parts in the Heater Unit, or you will be burnt.
Also be careful not to get burnt when you touch the printing paper as it may be very hot.

! NOTE

If removed a mis-fed paper inside the Fuser Door, scattered toner can be adhered to the next print.

7. Close Fuser Door (5) and Exit Cover (3).

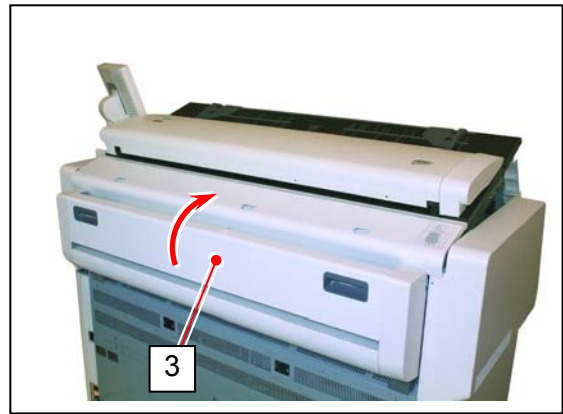
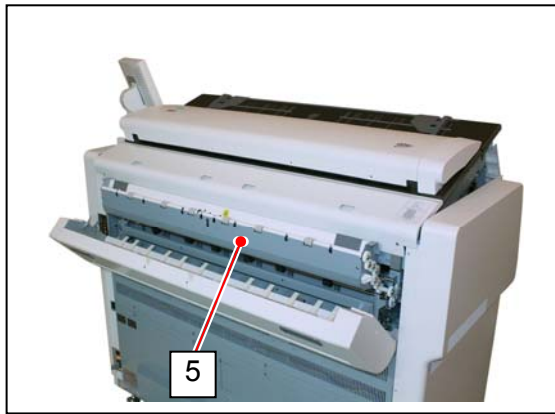

8. Gently close the Engine Unit.



! NOTE

Be sure to close the Engine Unit firmly until it locks at the correct position.

9. Replace Print Trays in the original position.

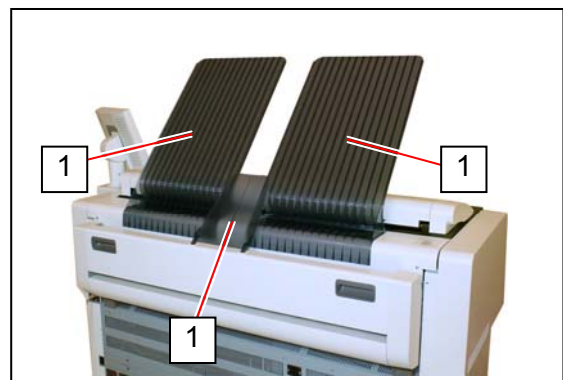

3. 1. 5 Stack Jam

1. Remove print(s) on Print Trays.



2. Remove all Print Trays (1).

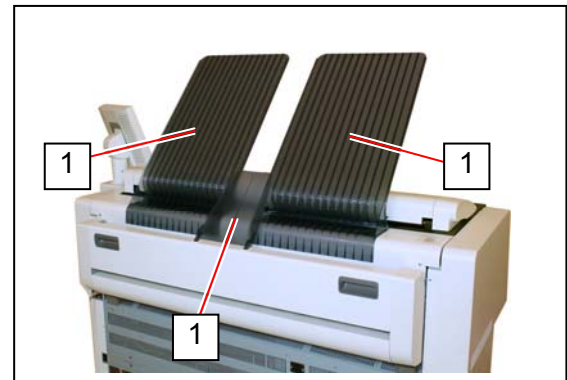

3. Pull up the Engine Unit Open Levers (2) to open the Engine Unit.

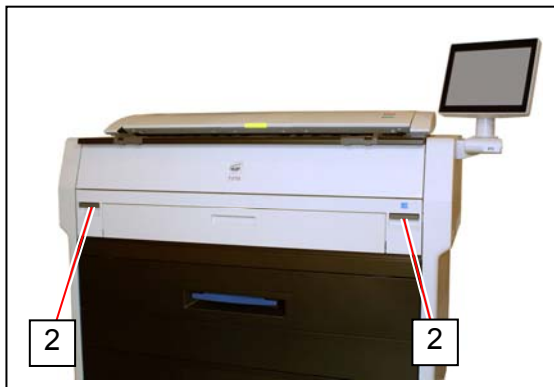

4. Pull and remove the jammed print to the top.

If the print cannot be removed, see [3.1.4 Fuser Jam] for the later procedure of clearing the jammed print.



5. Gently close the Engine Unit.



! NOTE

Be sure to close the Engine Unit firmly until it locks at the correct position.

6. Replace Print Trays in the original position.

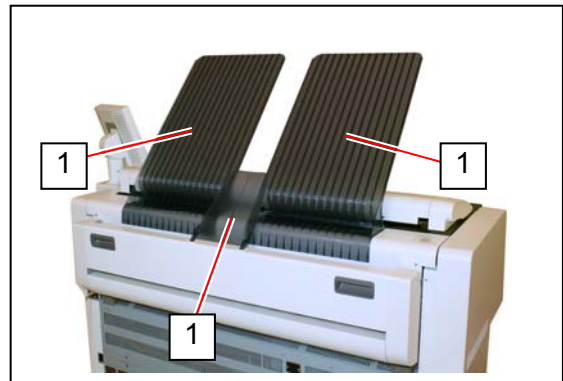

3. 1. 6 Original Jam

The scanner may stop feeding the original in the scanner if the original skews.
Pressing Scan Abort Button during scanning also stops the original in the scanner.
In both cases, LED Indicator flashes red.



1. Lift up both sides (1) of the Scanner Unit, and then remove the original.

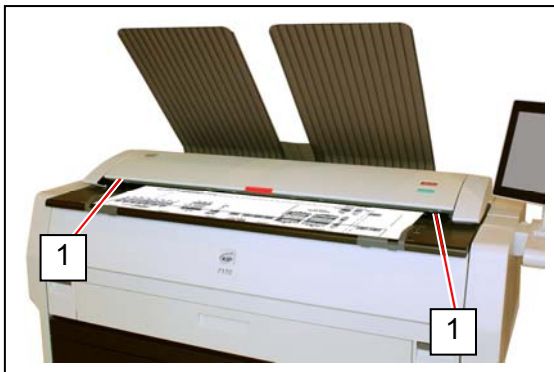

2. Gently press Scanner Unit down and firmly close it.

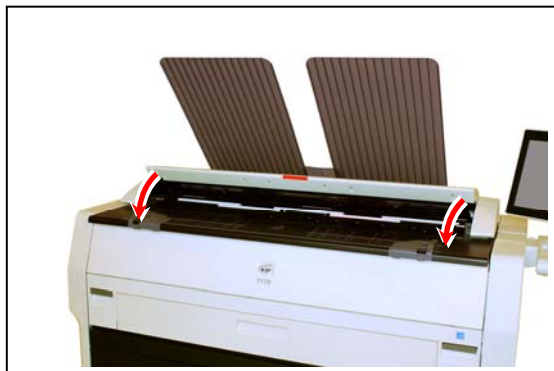

! NOTE

Press down Scanner Unit on both the sides to close it.
Do not close it by pressing only one side down.

3. 1. 7 Accessory Jam

The printing paper is mis-fed in the optional device such as Auto Stacker or Folder.
Remove the mis-fed paper making reference to the User's Manual of concerning device.

3. 2 Other Operator Call Error

3. 2. 1 Roll Replacement

When the printer is running out of an loaded roll media, the UI Screen will display “Roll Replacement” sign.

If there is no suitable roll media required for the current print job, the UI Screen will display “Roll Replacement” sign as well. Please load the required roll media to any Roll Deck.

For the roll replacement procedure, see [2.3 Replacing Roll Media].

3. 2. 2 Toner Empty

When the printer is running out of toner, the UI Screen will display “Toner Empty” sign.

For the toner supply procedure, see [2.4 Replacing Toner Cartridge].

3. 2. 3 Scanner Unit Open

The UI screen shows “Scanner Unit Open” if the Scanner Unit is open. (not closed properly)

For closing the Scanner Unit, see [3.1.6 Original Jam].

3. 2. 4 Printer Not Available

If the Exit Cover or the Engine Unit is open (not closed properly), the UI screen shows “Printer Not Available”.

Please check that either Exit Cover or Engine Unit is firmly closed. If it seems no problem, turn off and again on the machine’s power switch.

3. 2. 5 Accessory Error

If your finishing device (Auto Stacker, Folder) has an error, the UI screen of the printer would also show an error message.

For clearing errors on such devices, see the concerning device’s User’s Manual.

3.3 Service Call Errors

In case the following Error Codes for a serious failure appear in the UI screen;

PLEASE CALL YOUR TRAINED SERVICE PERSONNEL TO RESOLVE THE ERRORS.

No operation should be done by the customer.

Error Code
E - 000
E - 001
E - 002
E - 003
E - 010
E - 011
E - 012
E - 013
E - 031
E - 032
E - 033
E - 034
E - 040
E - 050
E - 070
E - 080
E - 081

If any of the above errors appear:

1. Turn off KIP 7170, and turn it on after an interval of 30 seconds or more.
2. If the same error code appears, turn off KIP 7170, and then unplug the printer from the wall outlet after an interval of two minutes for shutdown.
Call your service personnel.

Chapter 4

Maintenance

4.1	Scanner Unit	Page
4.1.1	Scan Glass, Feed Roller, Guide Plate	4-2
4.1.2	Sensor	4-5
4.2	Touch Screen	4-7

4. 1 Scanner Unit

4. 1. 1 Scan Glass, Feed Roller, Guide Plate

It is recommended to clean each Scan Glass, Feeding Rollers and Guide Plates as the scan/copy image may become defective if these parts are dirty.

NOTE

For ease of visual check, this document shows the Upper Unit fully open (not actual wide).

1. Turn off KIP 7170.
2. Lift up both sides (1) of the Scanner Unit.

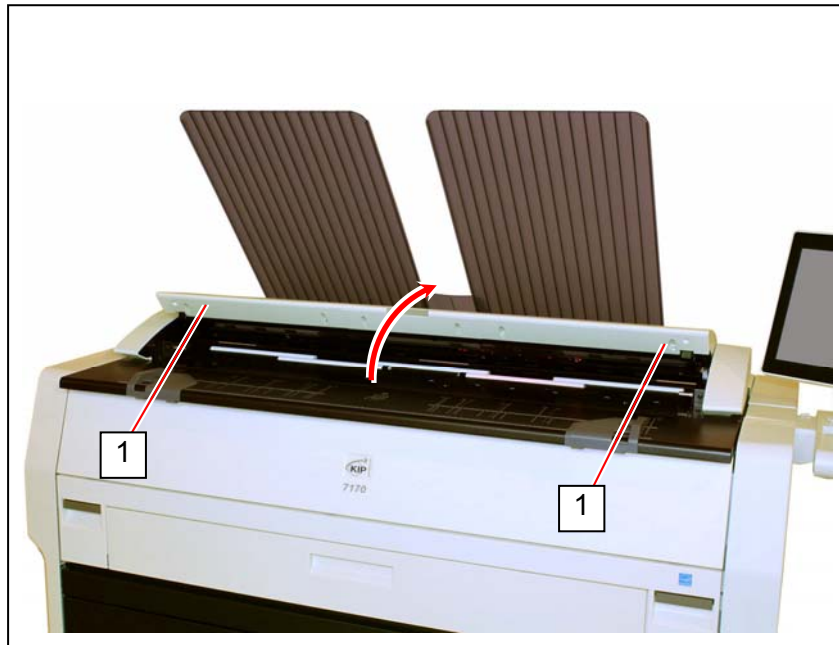

3. Gently wipe the Scan Glass (2) and Feed Rollers (white) (3) with a soft cloth. Equal mixture of water and neutral detergent can be used.

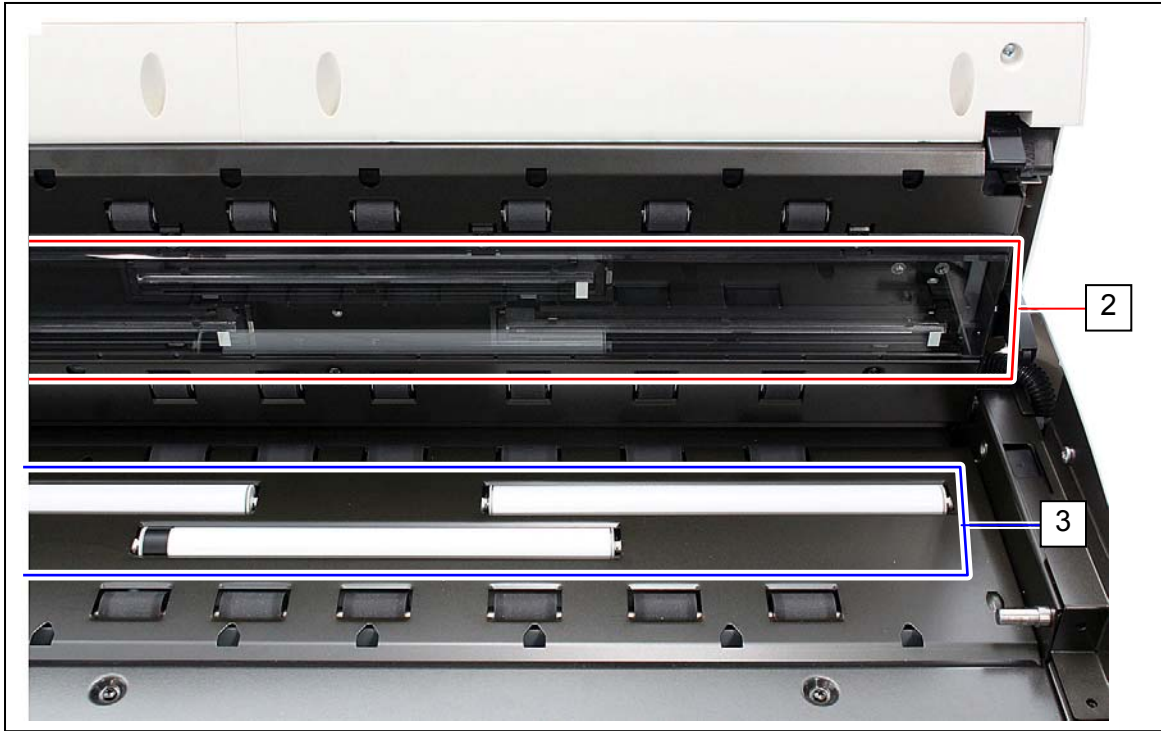

! NOTE

Do not use organic solvent, glass cleaner and anti-static spray for the cleaning.

4. Wipe the Feed Rollers (rubber) (4) with a dry cloth.

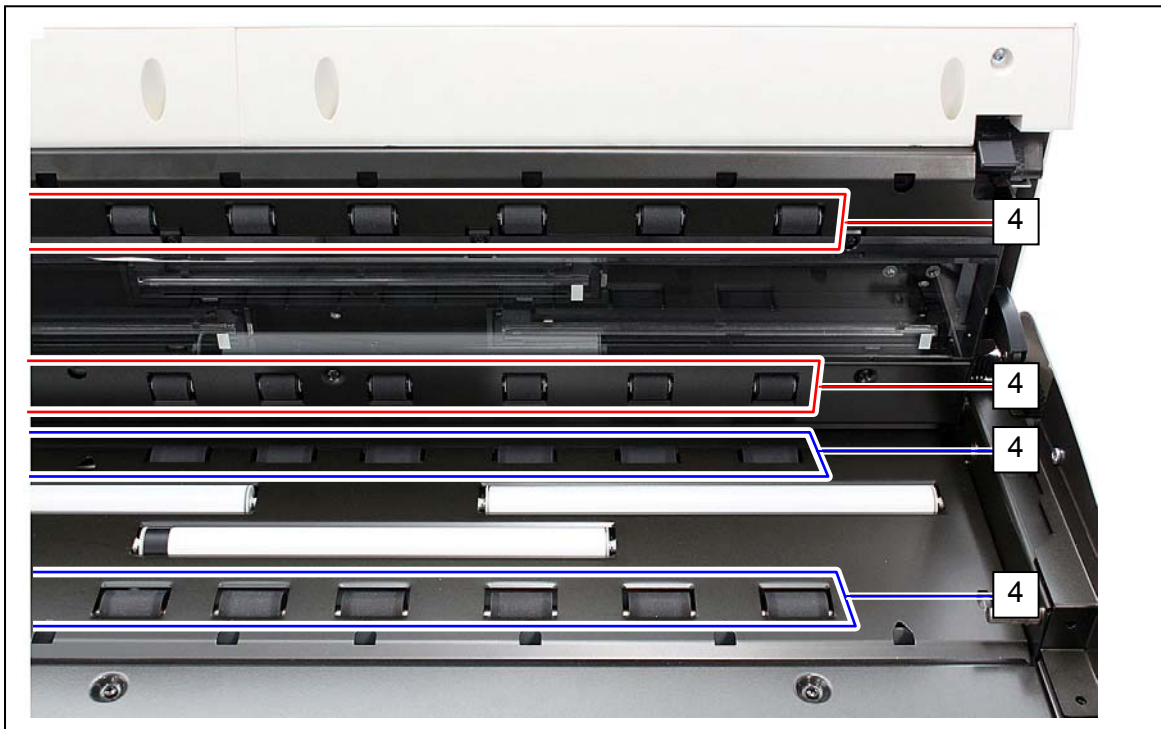

5. Wipe dry the Feeding Rollers.

6. Wipe the Upper Guide Plate (5) and the Lower Guide Plate (6) with a dry cloth.

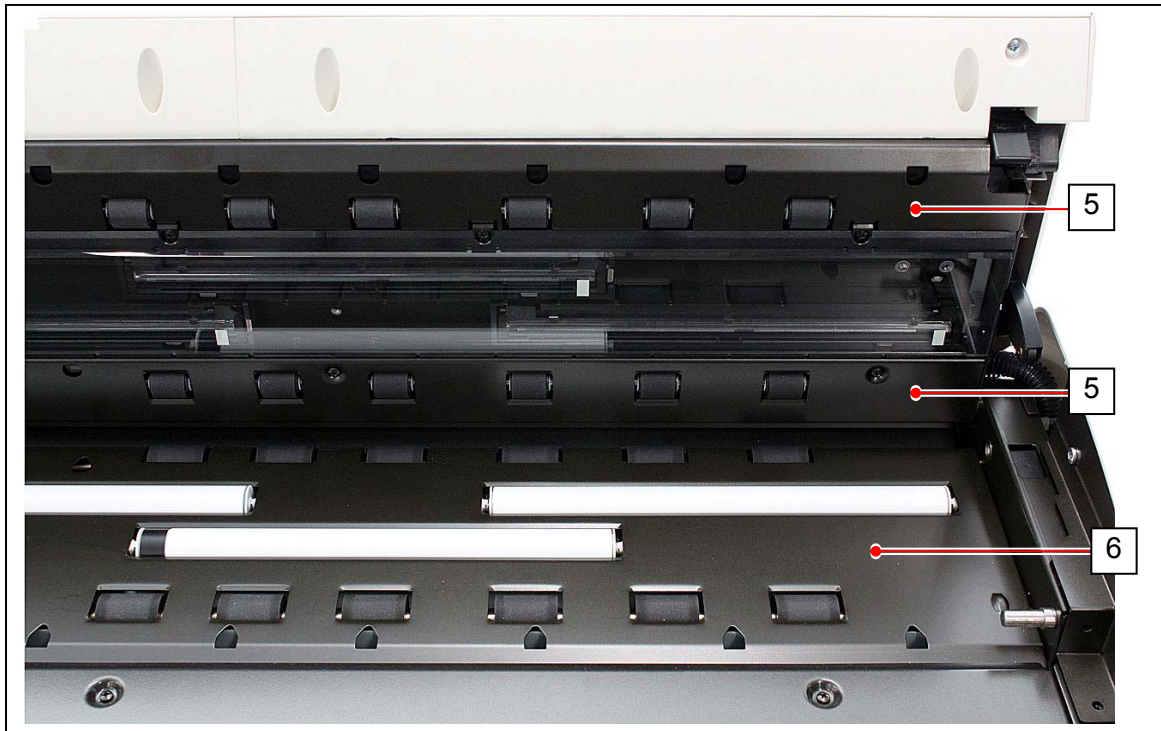

7. Gently press Scanner Unit down and firmly close it.

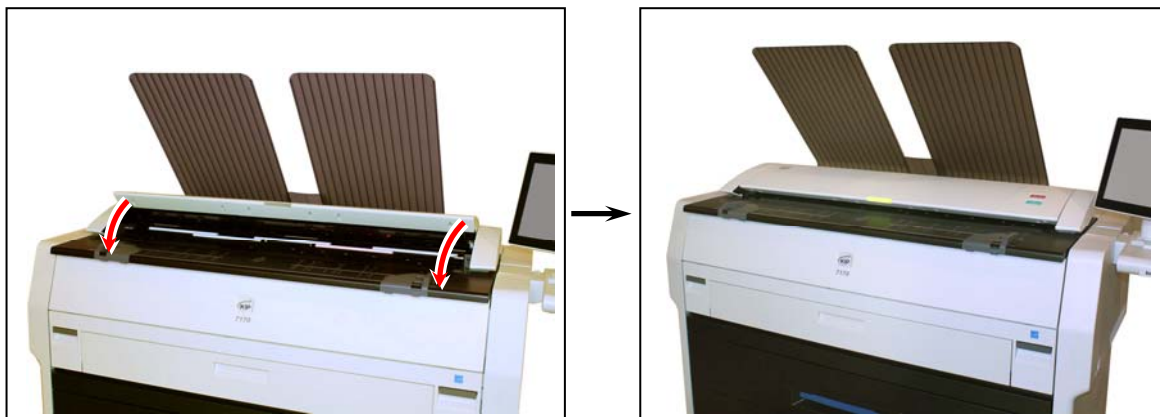

! NOTE

Press down Scanner Unit on both side to close it.
Do not close it by pressing only one side down.

4. 1. 2 Sensor

If Sensors are dirty, the original may be detected incorrectly.
Perform cleaning or as needed.

! NOTE

For ease of visual check, this document shows the Upper Unit fully open (not actual wide).

1. Turn off KIP 7170.
2. Lift up both sides (1) of the Scanner Unit.

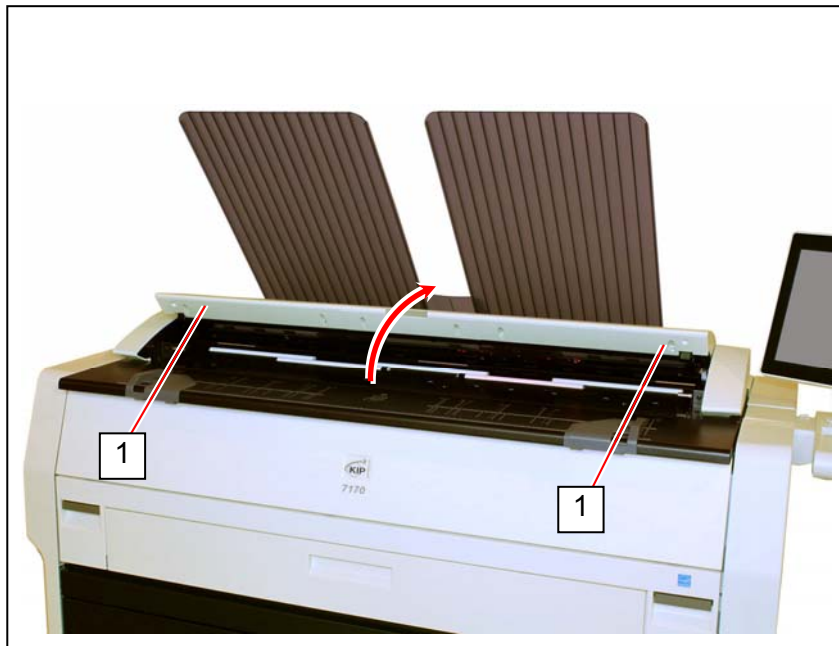

3. Gently wipe Sensors (2) with a dry cotton bud.

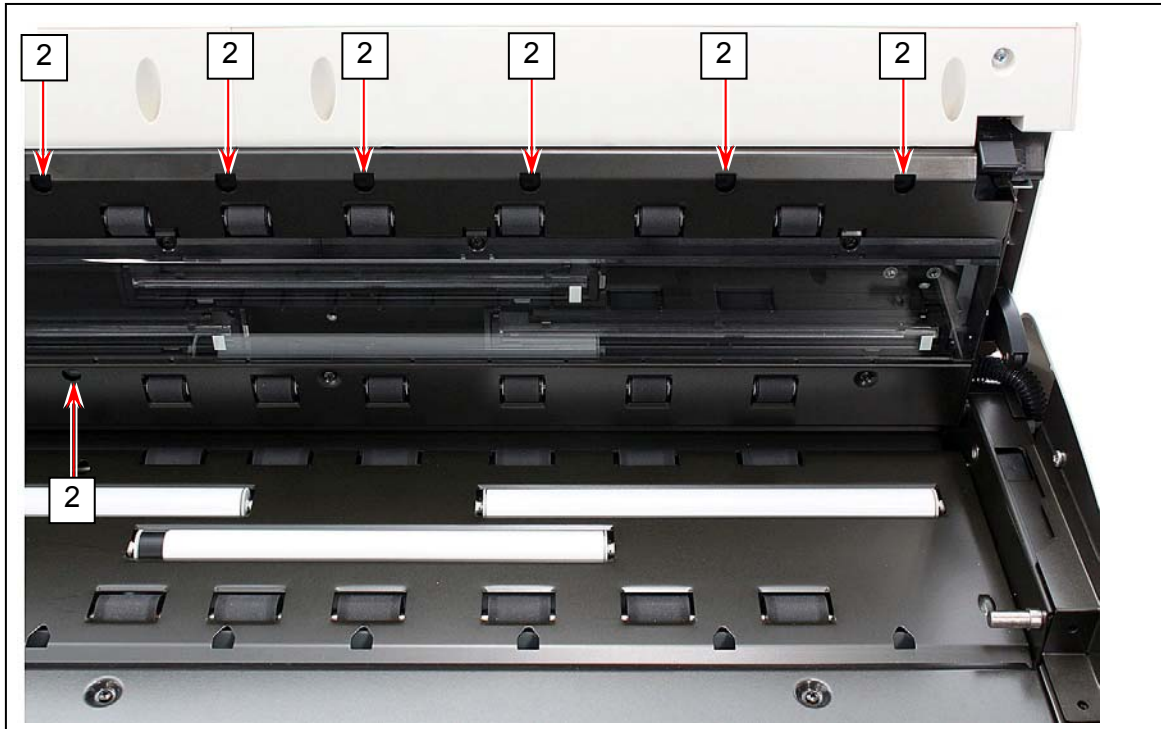

! NOTE

Do not use water, organic solvent, glass cleaner or antistatic spray for cleaning.

4. Gently press Scanner Unit down and firmly close it.

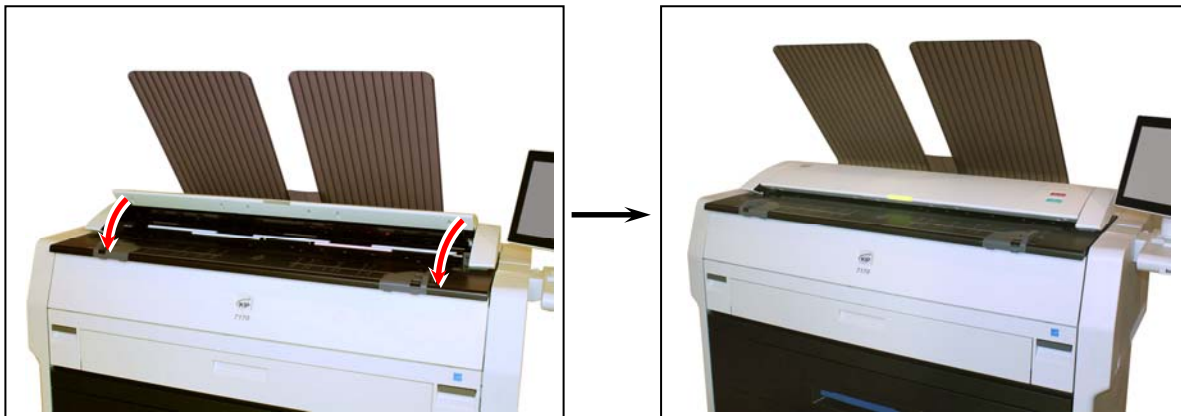

! NOTE

Press down Scanner Unit on both side to close it.
Do not close it by pressing only one side down.

4.2 Touch Screen

1. Wipe the Touch Screen with a dry cloth.



⚠ NOTE

Do not use water, alcohol, organic solvent and glass cleaner for the cleaning.