

Oster[®]
KITCHEN CENTER[®]
FOOD PREPARATION APPLIANCE BRAND

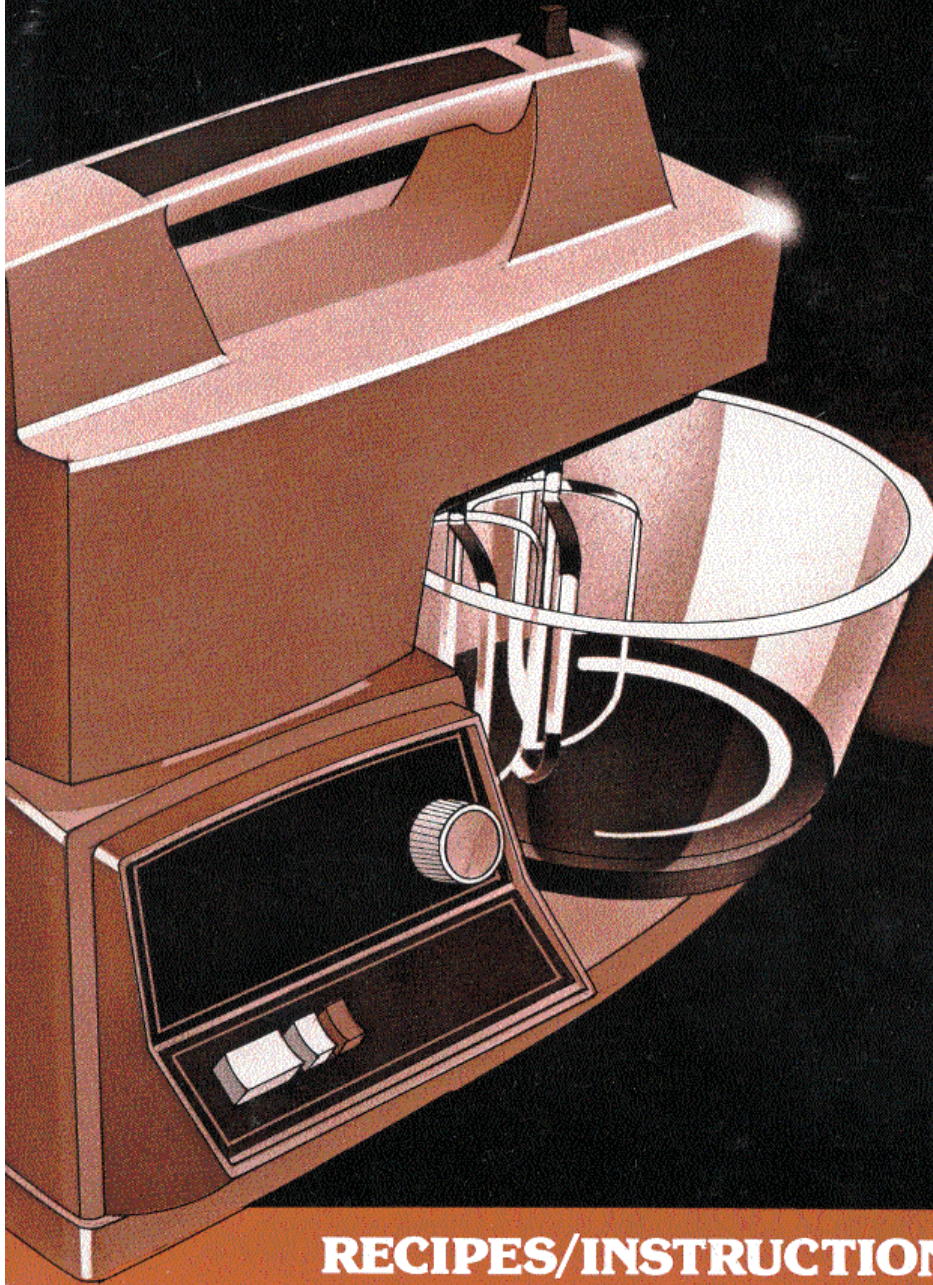

RECIPES/INSTRUCTIONS

GENERAL IMPORTANT SAFEGUARDS

MORE SPECIFIC "IMPORTANT SAFEGUARDS" ARE LOCATED BEFORE THE OPERATING INSTRUCTIONS OF EACH ATTACHMENT

When using electrical appliances, basic safety precautions should always be followed, including the following:

1. Read all instructions.
2. To protect against risk of electric shock, do not put motor base in water or other liquid.
3. Close supervision is necessary when any appliance is used by or near children.
4. Unplug from outlet when not in use, before putting on or taking off parts, and before cleaning. Do not attempt to remove or replace attachments with the motor operating.
5. Avoid contacting moving parts.
6. Do not operate any appliance with a damaged cord or plug, or after the appliance malfunctions or is dropped or is damaged in any manner. Return to the nearest authorized service facility for examination, repair, or electrical or mechanical adjustment.
7. The use of attachments not recommended or sold by the manufacturer may **cause fire, electric shock, or injury.**
8. Do not use more than one attachment at a time.
9. Do not use outdoors.
10. Do not let cord hang over edge of table or counter, or touch hot surfaces.
11. Never leave appliance unattended while it is operating.

SAVE THESE INSTRUCTIONS

"The maximum rating as marked on the Unit is based on the attachment that draws the greatest load. Other recommended attachments may draw significantly less power."

TABLE OF CONTENTS

	page		Page	Page
Important Safeguards		Tom and Jerry	36	Sour Cream Coffee Cake .. 53
General	1	Caribbean Whirl	36	Applesauce Cake .. 54
Blender	7	Italian Stallion	36	Harvey Wallbanger Cake .. 54
Mixer/Doughmaker	16	B r e a d s		
Salad Maker	.22	Sourdough Bread	37	C a k e F r o s t i n g
Introduction to Unit	4	Old-Fashioned Banana Bread	37	Harvey Wallbanger Cake Glaze 5 5
Motor Base-Care and Cleaning	5-6	Old-Fashioned White Bread	38	Chocolate Glaze 55
Optional Accessories	109-110	Onion Bread	38	Easy Fudge Frosting 55
How to Use Blender	8-15	Light Rye Bread	38	Lemon Cream Cheese Icing 55
How to Use Mixer/Doughmaker	17 - 21	Garlic Cheese Bread	38	Butter Frosting 56
How to Use Salad Maker	23-25	Raisin Cinnamon Bread	38	Vanilla Glaze 56
Food Processing		Cranberry-Orange Nut Bread	38	Bittersweet Chocolate Frosting .. 56
Charts	26-27	Refrigerator French Bread	39	Fluffy Frosting .. 56
Appetizers		English Muffins	40	C a n d i e s
Classic Swiss Fondue	28	Yummy Tomato Bread	40	Old Fashioned Fudge 5 7
Guacamole Dip	28	Crusty Honey Whole Wheat Bread	41	C o o k i e s
Zesty Salsa	29	Italian Bread Sticks	41	Peanut Butter Cookies 5 8
Shrimp Dip	29	Pumpkin Nut Bread	41	Oatmeal Chocolate Chip Cookies ... 5 8
Cottage Cheese "Sour Cream"	29	Old World Pizza	42	Salted Pecan Cookies ... 58
Salami Cheese Ball	30	Cheese and Sausage Filling	42	Spritz Cookies ... 59
Quick Liver Pate	30	Bran Muffins	42	Italian Snack Wafers ... 59
Baby Foods		Italian Herb Bread	43	Rum Balls ... 59
Basic Recipe - Meats and Vegetables	31	Herb Butter	43	Bittersweet Brownies ... 60
Canned or Fresh Fruits	31	Onion Pocket Bread	43	Meringue Kisses ... 60
Peach Pudding	31	Buttery Cheese Horns	44	Toffee Bars ... 60
Meat Combo Dish	31	Onion-Dill Bread	44	Desserts
Non-Alcoholic Beverages		Rich Biscuits	45	Chocolate Cheese Torte ... 61
Milk Shakes and Malts	32	Rye Onion Bread	45	Pots de Creme ... 61
Peach Cooler	32	Egg Bagels	46	Coconut a la Creme ... 61
Strawberry Milk Smoothee	32	Corn Fritters	46	Raspberry Macaroon Mousse ... 62
Tomato Juice Cocktail	32	Carrot Bread	47	Flan ... 62
Hawaiian Pineapple Crush	33	Lemon Glaze	47	Schaum Torte ... 62
Carrot-Pineapple Cocktail	33	Basic Quick Sweet Dough	47	Cold Orange Souffle ... 63
Pink Lassies	33	Sticky Pecan Rolls	48	Lemon Pudding ... 63
Strawberry Cooler	33	Orange-Date Crescents	48	Chocolate Dessert Fondue .. 63
Mexican Chocolate	33	Sugar Icing	48	Baked Alaska ... 64
Alcoholic Beverages		C a k e s		Quick Gelatin Mold ... 64
Daiquiri	34	Lemon Chiffon Cake	49	Chocolate Souffle ... 64
Bacardi	34	German Cheese Cake	49	Cherry Dream Torte ... 65
Brandy Alexander Frappe	34	Golden Carrot Cake	50	Mocha Bavarian ... 65
Grasshopper	34	Lemon-Orange Sauce	50	Glace Fruit ... 65
Golden Cadillac	34	Soft Gingerbread	50	S a u c e s
Pink Squirrel	34	Blender Cheese Cake	51	Orange Syrup ... 66
Koala Bear	34	Macaroon Pound Cake	51	Caramel Sauce ... 66
Cranberry Cooler	35	Yellow Cake	51	Easy Fudge Sauce ... 66
Orange Blossom	35	Jam Cake	52	Cherry Sauce ... 66
Frosty Sour	35	Graham Cracker Cake	52	Easy Vanilla Sauce ... 67
Pina Colada	35	Chocolate Fudge Cake	52	Lemon Sauce ... 67
Pink Lady	36	Election Cake	53	Quick Mocha Chocolate Sauce ... 67

TABLE OF CONTENTS

	Page		Page		Page
Strawberry Sauce	67	No-Crust Salmon-Zucchini		Strassburg Salad	95
Entrees		Q u i c h e	84	Vegetable Bean Salad	95
Mushroom Steaks	68	Sesame Zucchini Sticks	84	Salad of Gold	9
Mushroom Sauce	68	Sweet Sour Red Cabbage	84	Guacamole Salad	96
Spaghetti Sauce	69	Pancakes		Pineapple Daiquiri Salad	96
Confetti Rice Casserole	69	Pancake Mixes	85	Carrot Raisin Salad	97
Hot Chicken Salad	69	Mini-Choco Pancakes	85	Salad Dressings	
Chicken in Rice	70	Orange Cream Filling	85	Sour Cream Cucumbers	97
Sicilian Meat Loaf	70	Potato Pancakes	85	Sour Cream Roquefort	
Creamy Omelet	70	Sour Milk Pancakes	86	Dressing	97
30-Minute Chicken	71	Apple Pfannkuchen	86	Poppy Seed Dressing	97
Pork Chop Seasoned		Apple Filling	86	Mayonnaise	98
Coating	71	Shredded Potato Pancakes	86	Celery Seed Dressing	98
Sausage-Mushroom		Cheese Blintzes	87	Snappy French Dressing	98
Stuffing	71	Tostado Pancakes	87	Thousand Island	
Chicken with Parmesan		Chili Meat Sauce	87	Dressing	98
Cream Sauce	72	Basic Crepe Recipes	88	Louis Dressing	99
Blender Souffle	72	Parmesan Crepes	88	Creamy Italian Dressing	99
Pizza Omelet	73	Whole Wheat Crepes	88	Russian Salad Dressing	99
Spanish Rice	73	Dessert Crepes	88	Sandwich Spreads	
Ego Foo Yona	74	Chocolate Crepes	88	Peanut Butter	100
Soy Sauce	74	Herb Crepes	88	Egg Mustard Spread	100
Mile High Cheese Souffle	74	Cornmeal Crepes	88	Sauces	
Sole Elegante	75	Mushroom Filling		White Sauce	101
Lasagne Florentine		for Crepes	88	Cheese Sauce	101
Casserole	75	Pie Crust		Hollandaise	101
Lasagne	76	Standard Pastry	89	Fresh Horseradish	101
Pasta Primavera	76	Chocolate Cookie Crust	89	Bearnaise Sauce	102
Oriental Pot-Pourri Oriental	77	Bread Crumb Crust	89	Fresh Applesauce	102
Seasoning Sauce	77	Crumb Crust	89	Schloss Sauce	102
Pork Chop Suey	77	Buttery Nut Crust	89	Barbecue Sauce	103
Chili	78	No-Roll Pie Crust	90	Horseradish Sauce	103
Quick'n Easy Quiche	78	Pies		Tartar Sauce	103
Quiche Lorraine	78	Pumpkin Cheesecake	90	Sweet-Sour Basting	
Jams/Relishes/Preserves		Cherry Cream Cheese Pie	90	Sauce	103
Old-Fashioned Bread		Custard Pie	91	Soups	
and Butter Pickles	79	Pumpkin Pie	91	Canadian Cheese Soup	104
Cranberry Relish	79	Lemon Chiffon Pie	91	Cream of Broccoli Soup	104
Apple Butter	79	Vanilla Cream Pie	92	Gazpacho	104
Sauerkraut	80	Banana Cream Pie	92	Cream of Tomato Soup	105
Tomato Juice	80	Coconut Cream Pie	92	Vichyssoise	105
Zucchini Pickles	80	Lemon Meringue Pie	92	Minestrone Soup	105
Tangy Cole Slaw Relish	81	Lime Meringue Pie	92	Vegetables	
Peach Jam	81	Dutch Apple Pie	93	Corn Custard	106
Low Calorie		Crumb Topping	93	Almond Celery Oriental	106
Lo-Cal Applesauce	82	Choco-Mint Silk Pie	93	Stir Fry Fresh Carrots	106
Calorie Watchers		Salads		Cran-Orange Beets	107
Oressino	82	Cole Slaw Au Vin	94	Sour Cream Zucchini	
Creamy Celery Slimmer	82	Country Cole Slaw	94	Casserole	107
Breakfast in a Glass	82	Blender Cole Slaw	94	Au Gratin Potatoes	107
Herbed Tomato Soup	83	Refrigerated Slaw	94	Vegetables Polonaise	107
Green Goddess		Molded Mixed Vegetable		French Fries	108
Slim Dressing	83	Salad	95	Do-Ahead Fries	108
Lite Layered Salad	83	Molded Carrot Aloha	95	Freeze Your Own Fries	108
Dreamy Dressing	83	Salad	95	Oven-Baked French Fries	108

INTRODUCTION

Oster[®]

KITCHEN CENTER[®] BRAND

Food Preparation Appliance

It's a whole team in one compact appliance.

IT'S AN "OSTERIZER" BLENDER

Attach Blender Container to motor base and the exclusive "Controlled Power" feature lets you process food to the exact consistency you want. Controlled cycle blending adds extra versatility for superb creations.



IT'S A MIXER/DOUGHMAKER

Snap on mixer arm and attach beaters or dough hooks. The Electronic mixer easily handles all mixing jobs from the lightest meringues to the heaviest bread dough.



IT'S A SLICER/SHREDDER/ FRENCH FRY/SALAD MAKER

Attach Salad Maker to motor base and find the easiest way to slice and shred, even make French Fries! (NOTE: This unit not included with all models. Available as accessory for models without. See page 110 for other accessories available.)



**NOTE: THIS UNIT IS DESIGNED
FOR HOUSEHOLD USE ONLY**

MOTOR BASE PARTS

Everything you process begins with the motor base. The multi-speed motor base will maintain a desired speed, automatically compensating for the changing load of the various accessories. The drive shaft is permitted to move slightly from side to side to provide a "free floating" feature to reduce noise and wear. The motor is powerful, but it can be overloaded. To avoid this possibility, closely follow the instructions and use the quantities specified in the recipes in this book.

The motor base consists of three parts:

(A) CONTAINER HOLDER-For attaching the blender, mixer/doughmaker arm, salad maker, and optional accessories to the motor base.

(B) TURNTABLE BASE-For positioning the mixing bowls.

(C) SPEED CONTROL PANEL-For controlling the motor base. It consists of the following parts:

1. CONTROL DIAL-Located in the upper right-hand corner of the panel. Turn the knob to the right to increase speed and to the left to decrease speed.

2. OFF BUTTON-For turning the unit "OFF."

3. ON BUTTON - For continuous motor operation.

4. PULSE BUTTON-activates the motor when held in-used for controlled cycle blending. Use this only for blender operation. Also can be used to stop the motor momentarily by pressing and releasing the button.

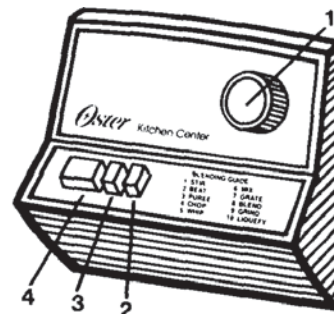
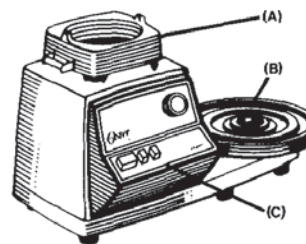

NOTE: Speed Selection

For Blender Operation- refer to the Blending Guide which is located on the Control Panel. Match the numbers to the words and dial the correct speed. Remember, the words are not descriptive of the blending action but only a reference for the speed used in the Oster recipes.

For Mixer Operation- refer to the Mixing Guide which is located on the Handle of the Mixer/Doughmaker Arm. Match the numbers to the words and dial the correct speed. The words in the Mixing Guide describe the mixing task you wish to perform.

ORDER OF OPERATION

1. SELECT SPEED-Turn Control Dial to the desired speed.
2. PULSE OR ON -Press either "PULSE" or "ON" buttons to begin processing. This will cause the unit's motor to run. The speed can be changed while the motor is running by turning the Control Dial. The PULSE button may be pushed and released to stop the motor momentarily.
3. TURN THE UNIT OFF- Push the "OFF" button when processing is complete. This will shut the unit off.

CLEANING

UNPLUG BEFORE CLEANING.

NEVER immerse Motor Base in water. Clean outside with a damp cloth.

MAINTENANCE

The Motor Base and other moving parts are permanently lubricated and never need oiling. Any service required should be performed by an authorized Oster service facility.

BLENDER IMPORTANT SAFEGUARDS

When using electrical appliances, the safety precautions in the General Important Safeguards section and the following safety precautions should always be followed.

1. Read all instructions.
2. Avoid contacting moving parts. Keep hands and utensils out of container while blending to reduce the risk of severe injury to persons and/or damage to the blender. If scraping, folding, etc. is necessary, turn the blender "OFF" and use a rubber spatula only.
3. The use of attachments, including canning or ordinary jars, agitators or processing assemblies, or sealing rings not recommended by the manufacturer, can result in malfunction and cause injury to the user and/or damage to the blender.
4. Blades are sharp. Handle carefully.
5. To reduce the risk of injury to persons, never place cutting blades on base without jar properly attached.
6. Screw on container bottom firmly. Injury can result if moving blades accidentally become exposed. If the container should turn when the motor is switched "ON," switch "OFF" immediately and tighten container in threaded container bottom. Always hold container while processing.
7. Always operate blender with cover in place.
8. When blending hot liquids, remove the feeder cap from the two-piece cover. Always begin processing hot liquids at the lowest speed setting to prevent spillage from the center opening and possibly causing burns.
9. Do not blend hot liquids in "Mini-Blend" containers.
10. Do not place blender jar or "Mini-Blend" containers in a conventional or microwave oven.

SAVE THESE INSTRUCTIONS

BLENDER PARTS

COVER

The Cover for your blender consists of two parts, the plastic Feeder Cap (1) and the vinyl Cover (2). The Cover is self-sealing, made of vinyl, and is resistant to absorption of odors and stains. The Feeder Cap is removable for use as a measuring cap and provides an opening for addition of other ingredients.

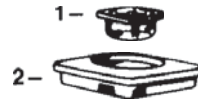

CONTAINER

The 5-cup (1.25liter) Container (3) for the blender is graduated for easy measurement and is molded of heat-and cold-resistant material. The convenient handle and pouring lip permit easy removal of liquid mixtures, while thicker mixtures are more easily removed through the bottom opening.

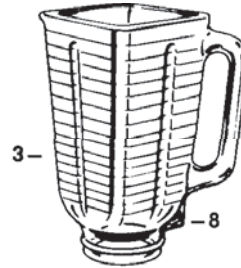

PROCESSING ASSEMBLY

The Processing Assembly consists of three parts: (4) a Sealing Ring used as a cushion between the Container and the Agitator; (5) an Agitator of high-grade stainless steel; (6) a threaded Container Bottom.

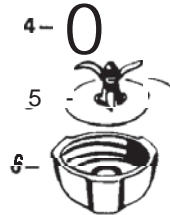

MOTOR BASE

The Stops (7) on Base Ring and Lug (8) on Container are used in the proper assembly of unit. (See Assembling Your Blender, page 9.)

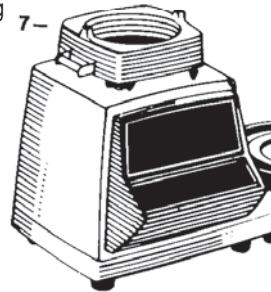

ASSEMBLING YOUR BLENDER

CAUTION: Follow these important steps to assemble, tighten, and mount blender Container quickly and correctly. INJURY MAY RESULT IF MOVING BLADES ARE ACCIDENTALLY EXPOSED.

ASSEMBLY OF CONTAINER



1. Turn container upside down so the small opening is at the top.
2. Place sealing ring on container opening.
3. Turn agitator blades upside down and place in mouth of container.
4. Thread container bottom to container. Engage threads properly. Screw on firmly.

TIGHTENING THE CONTAINER

1. To tighten container bottom, put assembled container securely into motor base ring with handle and lug in front of the right stop.
2. Using container handle, turn container to the left as far as possible. This insures that the container bottom is tightened properly. Remove container from motor base and mount.

Do not attempt to place the container on or remove it from the motor base while the motor is running.

MOUNTING THE CONTAINER

1. To operate blender, place assembled container in motor base ring with container lug against flat side of right motor base stop. If container lug does not rest against flat side of right stop, remove container assembly and place against flat side of left stop. Seat container firmly and operate.
2. To remove container, lift straight up. (If it is not easily removed, rock gently and lift up. Do not twist.) If container bottom cannot be loosened by hand, place assembled container into the motor base ring with handle in front of left side stop. Using container handle, turn container to the right until container bottom loosens.

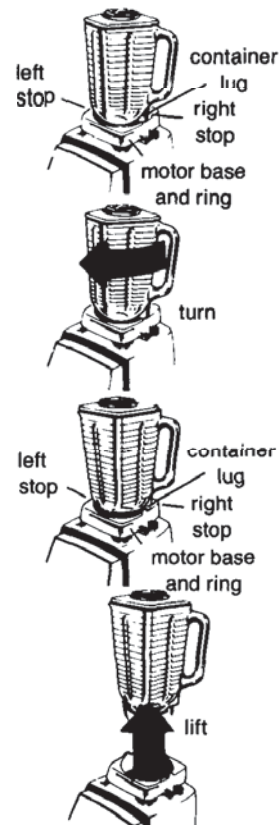

BLENDER OPERATING INSTRUCTIONS



10-SPEED CONTROLS



12-SPEED CONTROLS

USING "PULSE" BUTTON

The blender has 2 distinct methods of operation: CONTINUOUS run for blending, liquefying and fine chopping, and CONTROLLED CYCLE BLENDING for coarse chopping pieces of food, such as chopped vegetables, nuts or cheeses. Controlled cycle blending consists of turning the motor "on" and "off" intermittently, using the "PULSE" button. During the "on" portion of the cycle, food is chopped and tossed away from the blades. During the "off" portion of the cycle, the food is distributed around the blades to make processing more uniform. IN ALL THE RECIPES, GIVEN IN THIS BOOK, THE CONTROLLED CYCLE BLENDING FEATURE IS REFERRED TO AS A CYCLE. A cycle consists of operating the blender for about 2 seconds and then allowing the blades to coast to a stop.

NOTE: Use the Blending Guide for speed selection. The words refer to the speed selection used in the Oster recipes. The words are not descriptive of the blending action.

TO PROCESS FOODS

1. Assemble container (see page 9, Assembly of Container).
2. Put ingredients into blender container, cover firmly, and place container into ring on motor base (see page 9, Mounting the Container).
3. Select method of operation.

CONTROLLED CYCLE OPERATION

- a. Dial speed as given in recipe. Rest hand on container.
- b. Push "PULSE" button and hold in for 2 seconds. Release button and allow blades to come to a stop. Repeat as required by recipe.
- c. When processing is completed, push "OFF" button.

CONTINUOUS OPERATION

- a. Dial speed as given. Rest hand on container.
- b. Push "ON" button to start processing.
- c. If necessary to use rubber spatula, push "OFF" button. Repeat order of operation to continue processing.
- d. When processing is complete, push "OFF" button.

CAUTION: NEVER LEAVE BLENDER WHILE IT IS PROCESSING. If container should turn while motor is on, push "OFF" button immediately and tighten jar in container bottom. (See page 9, Tightening and Mounting the Container on motor base.)

CLEANING

Blender container parts are corrosion-resistant, sanitary and easily cleaned. Before first use and after every use, separate processing assembly and clean thoroughly in warm, soapy water. Rinse and dry well. **DO NOT WASH ANY PARTS IN AN AUTOMATIC DISHWASHER.** Reassemble container after cleaning so it will be ready for future use. Never store foods in your blender container.

MAINTENANCE

Periodically check all parts before reassembly.

Processing Blades-carefully turn blades in a counterclockwise direction. Blades should turn freely. Be careful of opposite edges of blades. The edges are sharp. If the processing blades are stuck or difficult to turn, **DO NOT USE BLENDER.**

Glass Container-if the container is chipped or cracked, **DO NOT USE BLENDER.** Further use could result in the blender container breaking during use.

USE OF DAMAGED OR NON-RECOMMENDED PARTS COULD RESULT IN A SEVERE PERSONAL INJURY AND/OR DAMAGE TO THE BLENDER.

The processing blades are permanently lubricated and never need oiling. **ANY SERVICE REQUIRED SHOULD BE PERFORMED BY AN AUTHORIZED OSTER SERVICE FACILITY**

“MINI-BLEND” CONTAINERS



“MINI-BLEND” Containers, **8-oz. (250mL)** and **30-oz. (625mL)**, are available as accessories and are not normally included with your unit. For proper assembly and tightening instructions, see page 9. The Containers allow for processing and storing foods in the same container. **DO NOT USE OTHER TYPES OF JARS FOR PROCESSING FOODS.** Ordinary jars may break or unscrew during processing. **DO NOT WASH ANY PARTS, INCLUDING CONTAINER, IN AN AUTOMATIC DISHWASHER.** **DO NOT** fill container above **MAXIMUM FILL LINE** to allow for expansion of foods while processing. **ALWAYS HOLD CONTAINER WITH ONE HAND WHILE PROCESSING.** Do not use in conventional or microwave oven.

HOW TO

BLENDER-CHOP (WATER METHOD)

(Chopping 2-4 cups (500mL-L) fruits and vegetables)

Cut vegetables into pieces about 1 inch (2.5cm) in size and place recommended quantity in blender container. COVER vegetables with cold water. Cover container and process for number of cycles indicated:

FOOD	QUANTITY	SPEED	CYCLES	FINISHED QUANTITY
Apples	3 cups (750mL)	MIX	2	2 cups grated (500mL)
Cabbage, red	3 cups (750mL)	GRIND	1	1½ cups (375mL)
Cabbage, white	3 cups (750mL)	GRIND	1	1½ cups (375mL)
Carrots	2 cups (500mL)	LIQUEFY	1	2 cups (500mL)
Green Pepper	3 cups (750 mL)	CHOP	1	1½ cups (375mL)
Onion	3 cups (750mL)	GRIND	1	1½ cups (375mL)
Potatoes	3 cups (750mL)	GRIND	1	2 cups (500mL)

When processing is finished, immediately pour through a strainer or colander and drain well.

The speeds and number of cycles listed above produce a medium-size chop. If a finer size is desired, process one additional cycle.

BLENDER-CHOP (DRY METHOD)

(Chopping 1 cup (250mL) or less)

Cut foods into pieces about 1-inch (2.5cm) in size and place recommended quantity in blender container or in "Mini-Blend" container (½ cup or 125mL only). Process for number of cycles indicated: DO NOT use "Mini-Blend" container to process cheese.

Apples	1 cup (250mL)	STIR	2	¾ cup (200mL)
Carrots	1 cup (250mL)	CHOP	2	1 cup (250mL)
Celery	1 cup (250mL)	CHOP	2-3	¾ cup (200mL)
Green Pepper	1 cup (250mL)	STIR	2	¾ cup (200mL)
Onion	1 cup (250mL)	PUREE	2	¾ cup (200mL)
Cheese, Cheddar	½ cup (125mL)	GRIND	3	½ cup (125mL)
Cheese, Swiss	1 cup (250 mL)	GRIND	4	1 cup (250mL)
Eggs, hard-cooked	2	STIR	2	¾ cup (200mL)

Nuts — ½ cup (125 mL) in "Mini-Blend" container or 1 cup (250mL) in large container

Peanuts	WHIP	3
Almonds	MIX	4
Pecans	WHIP	2
Walnuts	WHIP	2

BLENDER-CRUMB

Bread — Tear one slice of fresh, plain or buttered, bread into 8 pieces and put into blender container. Cover and process for number of cycles indicated:

Bread	QUANTITY	SPEED	CYCLES	FINISHED QUANTITY
Coarse	1 slice	STIR	1	½ cup (125mL)
Regular	1 slice	GRATE	2	½ cup (125mL)
Fine	1 slice	LIQUEFY	Continuous	½ cup (125mL)

Crackers, Cookies — Break crackers and cookies into blender container. Cover and process for number of cycles indicated:

Zwieback	6	GRIND	4	½ cup (125mL)
Graham Crackers	8	GRIND	3	½ cup (125mL)
Soda Crackers	16	GRIND	2	½ cup (125mL)
Chocolate Wafers	10	GRIND	3	½ cup (125mL)
Small Coconut Cookies	8	GRIND	3	½ cup (125mL)
Vanilla Wafers	16	GRATE	3	½ cup (125mL)

If finer size is desired, process one additional cycle.

HOW TO

BLENDER-GRIND

**Nuts
Oats**

**Rice
Wheat**

**Peppercorns
Whole spices**

Coffee Beans

Put ½ cup (125mL) in "Mini-Blend" container or 1 cup (250mL) in the blender container. Cover and process at GRIND until desired grind is obtained. Longer processing will give a finer grind. **NOTE:** Whole ginger root and nutmeg are extremely hard spices, and it is recommended that only two or three 1-inch (2.5cm) pieces of ginger or 3 nutmegs be processed at one time. Break nutmeg with a nut cracker before processing. Process only in glass blender container at LIQUEFY. Coffee beans are quickly and evenly ground. Put ½ cup (125 mL) at a time into "Mini-Blend" container and process at:

GRIND — 10 cycles for percolator

GRIND — 15 cycles for drip

BLENDER-GRATE

Semi-Hard, Hard Cheese (Refrigerator Cold)

Cover and turn blender to BLEND. With motor on, remove feeder cap and drop no more than 1 cup (250mL) of 1-inch (2.5cm) cheese cubes into container. Push "OFF" button. Remove cheese through bottom of blender container. Repeat if necessary.

RECONSTITUTE

Frozen Concentrated Juices and Soups — Always put water (liquid) into the blender container first. Put frozen concentrate in the liquid. Cover container and hold jar while processing at STIR only until well mixed.

Dry Milk — Put water and dry milk solids into the blender container. Cover and process at STIR only until well mixed.

LIQUEFY

Fruits, Vegetables and Other Solid Foods with Addition of a Liquid — The blender is not a juice extractor, but it will break down the fibrous parts of vegetable and fruit pieces so that all the flavor is released into a liquid. This liquid may be water or any prepared fruit or vegetable juice. Use the following table only as a guide — you may want a thicker or thinner juice.

AMOUNT OF FRUIT OR VEGETABLE AMOUNT OF LIQUID YIELD

1 medium apple, peeled, cored, cut in eighths	1 cup (250mL)	About 1½ cups (375 mL)
3 small carrots, cut in 1-inch (2.5cm) pieces	1 cup (250mL)	About 1½ cups (375mL)
2 large celery stalks, cut in 1-inch (2.5cm) pieces	1 cup (250mL)	About 1½ cups (375mL)

Place ingredients in blender container. Cover and process at LIQUEFY until pieces of food are no longer visible. Remove feeder cap and add 3 or 4 ice cubes, one at a time, to thoroughly chill liquid. Continue processing until cubes are dissolved. (If desired, this juice may be strained through a fine sieve to remove the small fibrous particles.)

Due to variations in size, consistency and age of food items, it may be necessary to increase or decrease the number of cycles indicated in this chart and in the recipes throughout the book to achieve desired results.

BLENDING TIPS

- **To blend ingredients of a heavy consistency**, such as cheese dips and sandwich spreads, it is necessary to use a rubber spatula to keep the mixture around the blades. To use spatula, turn motor off, unplug unit and remove the cover; move the spatula down along sides of the container and push the ingredients from the sides of the container to the center. Cover and start motor. Repeat procedure as necessary.
- **To correct curdled mayonnaise**, empty contents from container, blend another egg and $\frac{1}{4}$ cup (50mL) of the liquefied or curdled mayonnaise until mixed. Remove feeder cap and pour remaining mayonnaise instead of oil into center of container. Use rubber spatula to blend oil in mixture.
- **To smooth gravy or white sauce** which may be lumpy, pour into a measuring cup and then put about $\frac{1}{2}$ cup (125mL) into blender container. Cover and process at WHIP Remove feeder cap and, with motor running, gradually add remaining gravy or sauce. Continue to process until smooth.
- **To chop giblets for gravy**, cook the giblets in water or broth, then cool to room temperature. Cut giblets into 1" (2.5cm) pieces, put in blender container, and cover with cooled cooking liquid. Cover container and process 2 cycles at GRIND. (If giblets are not chopped finely enough, process for one or two additional cycles.)
- **To make butter** using sweet or sour heavy cream, pour into blender container, cover and process at WHIP until butter forms, Pour into strainer to drain off liquid, then put butter into small bowl and press with a spatula to remove as much liquid as possible. Add salt while kneading butter. Try adding 1 tablespoon (15mL) dried herbs (parsley, tarragon, savory or a garlic clove) per cup (250mL) of cream for delightful herb butter.
- **To grate lemon or orange peel**, freeze thin strips of orange and lemon peel, then process $\frac{1}{2}$ cup (125mL) at a time in "Mini-Blend" container at BLEND.
- **To grate cheese**-For best results when grating Cheddar or Swiss cheese, be sure it is refrigerator-cold. When blending cheese for dips and spreads, remove from refrigerator about 30 minutes before use.
- **To grind poppy seed** for filling, place $\frac{1}{2}$ cup (125mL) poppy seeds in "Mini-Blend" container and process at GRIND until seeds are crushed and moist. Stop blender once or twice to scrape down seeds from top of container.
- **To grate fresh coconut**, set speed at LIQUEFY, remove feeder cap, start motor and drop coconut pieces into revolving blades. After grating 1% cups (375mL) coconut, empty container and repeat until all coconut is grated.
- **To save Cheddar or Processed cheese** which has become hard and dry after long storage in refrigerator, cut into pieces and grate in blender container. Process at BLEND until finely grated, then use for casserole toppings, in sauces, etc. DO NOT use "Mini-Blend" containers when processing hard cheese.
- **To chop candied or dried fruit and dates**, put into blender container, cover with cold water. Cover and process 2-3 cycles at LIQUEFY or until desired consistency is reached. Drain off water through colander. Dry fruit on paper toweling. (If your recipe has enough liquid to cover fruit in blender container, use that liquid instead of water. Do not drain.) Dried or candied fruit and dates can also be chopped in the following manner. Put $\frac{1}{2}$ cup (125mL) of fruit and $\frac{1}{2}$ cup (125mL) flour in blender container. Cover and process 2-3 cycles at LIQUEFY until desired consistency is reached.

ALWAYS: Operate your unit on a hard, flat surface such as a counter top or table.

NEVER: Operate unit on a tablecloth, plastic, paper or other materials which might diminish or stop air-flow to the motor.

OPERATING DO'S AND **DON'TS**

DO:

1. Use only the line voltage and frequency as specified on bottom of Motor Base.
2. Always operate your unit on a clean, dry surface to prevent air from carrying foreign material or water into the motor.
3. **PUT LIQUID PORTIONS OF RECIPES INTO THE CONTAINER FIRST** unless the instructions in recipes specify otherwise.
4. Cut all firm fruits and vegetables, cooked meats, fish and seafoods into pieces no larger than $\frac{3}{4}$ to 1 inch (1.8 to **2.5cm**). Cut all kinds of cheeses into pieces no larger than 1 inch (**2.5cm**).
5. Use rubber spatula to push ingredients to be chopped into liquid portion of recipe **ONLY** when motor is OFF
6. Place cover firmly on the container before starting, and rest hand on the container cover when starting and running motor.
7. Remove heavy dips and spreads, nut butters, mayonnaise and products of similar consistency by removing the processing assembly and pushing the mixture out through the bottom opening into serving dishes or storage container.
6. Pour mixtures of liquid or semi-liquid consistency, such as pancake batters, from the container.
9. When processing hot ingredients, remove the feeder cap to allow steam to escape and prevent ingredients from erupting.
10. Increase speed if the motor seems to labor when processing to prevent overloading of the motor.
11. Use a "Mini-Blend" container or **5-cup (1.25L)** blender container to process citrus rind, coffee beans or cereal grains. **USE ONLY GLASS BLENDER CONTAINER** to process whole spices and hard cheeses.

DON'T:

1. **DON'T** process mixtures too long. Remember, the blender performs its tasks in seconds, not minutes. It is better to stop and check the consistency after a few seconds than to overblend and have a mushy or too finely ground product.
2. **DON'T** overload the motor with extra-heavy or extra-large loads. If the motor stalls turn off immediately, unplug cord from outlet, and remove a portion of the load before beginning again.
3. **DON'T** put ice cubes into the container without at least one cup (250mL) of liquid. Ice cubes will not process properly without liquid.
4. **DON'T** attempt to remove the container from the motor base or replace it until the motor has coasted to a complete stop. Blender parts can be damaged.
5. **DON'T** remove the container cover while processing, as food spillage can occur. Use the Feeder Cap opening to add ingredients.
6. **DON'T** place or store agitator blades or assembly on the blender base without first correctly assembling to the container. Severe injury can result if the blender is accidentally turned on.
7. **DON'T** use any utensils, including spatulas, in the container while the motor is running. They can catch in the moving blades, break the container and cause severe injury.
6. **DON'T** use ANY jar not recommended by manufacturer for processing foods. Jars other than manufacturer jars can break or loosen during processing and cause severe injury.
9. **DON'T** use "Mini-Blend" containers for processing whole spices or hard cheeses, as they can break the container and cause severe injury.

MIXER/DOUGHMAKER

IMPORTANT SAFEGUARDS

When using electrical appliances, the safety precautions in the General Important Safeguards section and the following safety precautions should always be followed.

1. Read all instructions.
2. Avoid contacting moving parts. Keep hands, hair, clothing, as well as spatulas and other utensils away from beaters and dough hooks during operation to reduce the risk of injury to persons and/or damage to the mixer.
3. Remove beaters or dough hooks from mixer before washing.
4. Never place fingers between the mixer arm and motor base when it is in the raised position. If mixer should drop, injury could result.
5. It is extremely important to insert beaters or dough hooks in the correct position. Incorrectly inserted beaters or dough hooks may cause beater damage or bowl breakage. See "Assembly" instructions page 18.
6. DO NOT attempt to prepare recipes containing more than 7 cups (1.75L) of flour. Larger amounts will overload motor and may cause motor failure.

SAVE THESE INSTRUCTIONS

USE AND CARE CAUTIONS FOR GLASS BOWLS:

Failure to follow these instructions can cause breakage.

DO NOT USE ON TOP OF STOVE.

DO NOT use in a toaster oven.

DO NOT add liquid to a hot bowl.

DO NOT handle hot bowl with a wet cloth or place on a wet or cold surface.

DO NOT use chipped or cracked bowls.

DO NOT use scouring pads or any object that will scratch the bowls.

DO NOT use in oven, under broiler or in a microwave oven.

PARTS

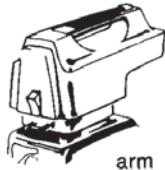

arm

MIXER/DOUGHMAKER

ARM: The Mixer/Doughmaker Arm has been designed to function as a mixer as well as a doughmaker. The Arm locks securely to Motor Base for mixing and doughmaking operation.



turntable

TURNTABLE: The Turntable has been designed to provide smooth, free rotation of the bowl in the preparation of heavy mixtures.



bowls

BOWLS: The 4-quart (4L) and 1 1/2-quart (1.5L) mixing bowls are designed for use with the mixer/doughmaker. The ridge on the bottom of the bowl fits into the corresponding groove on the turntable. Your model Kitchen Center appliance may come with either glass or stainless steel bowls, depending on which style was purchased.

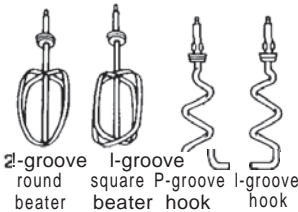

2-groove round beater, 1-groove square beater, P-groove hook, 1-groove hook

BEATERS AND HOOKS: The Collars, located on the shaft of the Beaters and Hooks, have identifying grooves for proper assembly. Note that the two Dough Hooks and Beaters have either 1 or 2 grooves and fit into the matching sockets in the underside of the Mixer Arm. **NOTE:** The round Beater has a nylon button on the tip, and the square Beater does not.



trigger

TRIGGER — hinge lock that secures Mixer/Doughmaker Arm into position on Motor Base.



latch

RELEASE LATCH — allows Arm to be raised or lowered. Cams will drop into position automatically to support Arm in raised position.



pivot pin

PIVOT PINS — located on each side of Motor Base ring. Trigger and Release Latch snap onto Pivot Pins so that Arm locks securely in place.



ejector

EJECTOR — small lever located on top of Mixer/Doughmaker Arm. Move Ejector Lever to side to eject Beaters or Dough Hooks.

ASSEMBLY

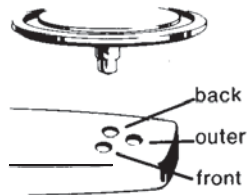

1. Position TURNTABLE into correct socket on Motor Base. The 2 inner sockets are for use with the small Bowl. The socket toward the back of Motor Base is used for small Bowl and Beaters. The socket toward the front on the Motor Base is for use with the Dough Hooks. SEE DIAGRAMS ON MOTOR BASE. The outer socket is designed for use with the large Bowl, using either the Beaters or the Dough Hooks. SEE DIAGRAMS ON MOTOR BASE.

2. On underside of Mixer Arm, locate four (4) sockets and identifying label as shown.

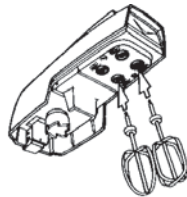
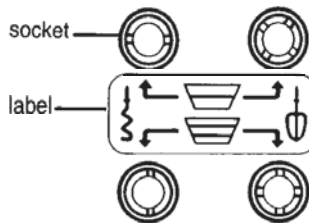

To Insert Beaters:

Locate sockets identified by the symbol . Put the Beater with one groove in the socket identified with one groove and snap into locked position. Put the Beater with two grooves in the socket identified by two grooves and snap into locked position.

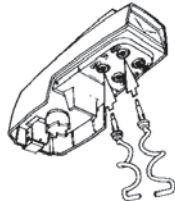

To Insert Dough Hooks: Same manner as Beaters except on side identified by the symbol . ALWAYS RECHECK THE PROPER ASSEMBLY OF DOUGH HOOKS BEFORE KNEADING BREAD. IF THE DOUGH HOOKS ARE NOT PROPERLY PLACED IN THE CORRECT SOCKETS, THE DOUGH WILL CLIMB THE DOUGH HOOKS.

NOTE: Do not insert Dough Hooks or Beaters into Mixer Arm at the same time.

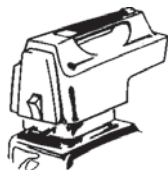

3. Mount Arm on Motor Base by pressing Trigger and Release Latch and lowering onto pivot pins. Release Trigger and Latch. Arm should be securely fastened. Trigger will snap out.



4. Press Release Latch on the underside of Mixer/Doughmaker Arm, then raise Arm. Releasing pressure on Latch will permit cams to automatically drop into position and lock to support Arm in raised position. CAUTION: Never place fingers between Arm and Motor Base. If Arm should drop, injury could result.

HOW TO OPERATE

1. Assemble mixer/doughmaker and mount on motor base (Fig. 1).
2. Always recheck the proper assembly of dough hooks before kneading bread. *If the dough hooks are not properly placed in the correct sockets, the dough will climb the dough hooks.*
3. Add ingredients to bowl as instructed by recipe.
4. Press release latch and lower arm and beaters or dough hooks gently into mixing bowl (Fig. 2).
5. Select proper speed by referring to MIXING GUIDE on top of mixer/doughmaker arm. Turn Control Dial to reach desired speed. Numbers on control panel correspond with mixing speeds in MIXING GUIDE. Due to varying consistencies of batters and doughs, it may be necessary to adjust speed.
6. Push "ON" button and process ingredients for time specified in each recipe. In normal use, unit should never stall. If motor stalls, turn unit "OFF" and check recipe.
7. While mixing or kneading, use rubber spatula to move dry ingredients from sides and bottom of bowl into mixture. Guide bowl gently, if necessary.
6. Push "OFF" button if the motor needs to be stopped for adding ingredients or scraping bowl. To start motor again, push "ON" button.
9. When mixing or doughmaking is completed, push "OFF" button.
10. Press release latch (Fig. 2) and lift arm to upright position. Release pressure on release latch. To release beaters or hooks, move ejector lever to side (Fig. 3).

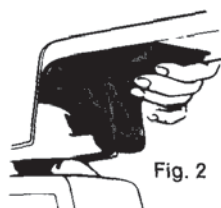
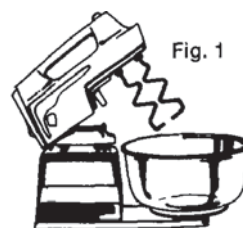

CLEANING

DO NOT IMMERSE ARM OR TURNTABLE IN WATER. Beaters, dough hooks and bowls are dishwasher safe. Dry beaters and dough hooks immediately after cleaning. Do not tap beaters or dough hooks on side of bowl to remove dough.

Wipe mixer/doughmaker arm and turntable with a soft, damp cloth to clean.

MAINTENANCE

The mixer/doughmaker arm and turntable are permanently lubricated and never need oiling. Damaged beaters, dough hooks and broken bowls should be replaced with genuine replacement parts. Other replacements may cause bowl breakage during use. (Stainless steel bowls are not breakable, but if replacement bowls are necessary, use only genuine replacement parts.)

ANY SERVICE REQUIRED SHOULD BE PERFORMED BY AN AUTHORIZED OSTER SERVICE FACILITY.

'BREAD MAKING TIPS'

BREADMAKING

The method of breadmaking used in this booklet is a new and fast method. You avoid the traditional time and energy-consuming aspect of breadmaking because the machine does the work. This method requires a **120-130°F (50-54°C)** temperature for the liquid ingredients added to the flour which speeds rising times considerably. The Doughmaker develops the bread structure fast, giving better support to your bread.

BREAD IS NUTRITIOUS

Bread and cereals are one of the four basic food groups required daily to maintain a properly balanced diet. Four or more servings daily of whole grain, enriched breads or cereals are recommended for children and adults alike. And, what better way to meet these requirements than with homemade bread, fresh from the oven.

INGREDIENTS

Yeast -Yeast is the leavening ingredient that makes breads rise. Yeast is a living organism that grows and survives on sugar, moisture and warmth. The gas that is produced as the yeast grows makes bread light, flavorful and delicious to smell.

There are two forms in which yeast is sold:

1. Active dry yeast comes in foil packages $\frac{1}{4}$ ounce (7g) each. It stays fresh when stored in a cool, dry place until it reaches its expiration date. When used in the Doughmaker method, active dry yeast requires a **120-130°F (50-54°C)** liquid, enabling doughs to rise quicker.
2. Compressed yeast is available in **0.6-ounce (17g)**, **1-ounce (28g)** and **2-ounce (57g)** cakes. It must be refrigerated and used before expiration date. It can be frozen for several months. Defrost at room temperature when ready to use. Compressed yeast and active dry yeast can be used interchangeably; one package active dry yeast equals one **0.6-ounce (17g)** cake.

Flour — Gluten is the protein in the flour which gives structure to your bread. When dough is stirred and kneaded, the gluten is developed. The more kneading, the better the structure or texture. Gluten content varies with the type of flour. All-purpose or wheat flour has a high gluten content. Whole wheat and rye flours have less gluten and must be used in combination with all-purpose or wheat flour. Rice and soy flour have no gluten. They must be used with other flours.

Liquid — Milk, water and potato water are common liquids used in breadmaking. Milk produces a soft crust; water makes bread crust crunchy. All liquids must be warmed to activate the yeast. A temperature of **105-115°F (40-46°C)** is used when dissolving compressed yeast before adding to flour mixture; **120-130°F (50-54°C)** temperature is used for the quick-rise method (dry yeast added to dry ingredients) which is used throughout this book.

Sugar — Yeast needs sugar to grow and produce gas to make the dough rise. Sugar also browns the crust and adds flavor. Molasses, brown sugar and honey can also be used in place of conventional granulated sugar.

Salt — Salt adds flavor and controls rising time in bread.

Fat — Margarine, butter, salad oils or lard adds flavor, makes the dough elastic and the finished product tender.

BREAD MAKING HINTS

THE PERFECT LOAF

Rising — An even temperature of **80-85°F (26-30°C)** is needed for proper development of the **yeast**. There are a few **exceptions**; consult individual recipes for exact procedure.

Shaping — For shaping into 9" x 5" x 3" (23 x 13 x 8cm) loaves, follow these directions:

1. Divide dough as stated in recipe. Roll each section into a 14" x 7" (35 x 18cm) rectangle on a lightly floured board. A rolling pin works well and forces out any air bubbles. (Fig. 1)
2. Beginning with the smaller side, roll up jelly-roll style, sealing well with pressure from the heel of the hand. (Fig. 2)
3. Pinch edges and ends to seal. (Fig. 3)
4. Place seam-side down in a well-greased 9" x 5" x 3" (23 x 13 x 8cm) loaf pan.

Test for "double in size" — Press the tips of two fingers lightly $\frac{1}{2}$ inch (1.25cm) into the dough. If the impressions remain, it has doubled. (Fig. 4)

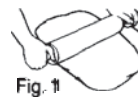

Fig. 1



Fig. 2



Fig. 3



Fig. 4

BAKING PAN MATERIALS

Use dull metal pans when possible. Shiny pans require longer baking time. When using glass baking pans, reduce temperature called for in recipe 25°F (15%).

Baking — Always preheat oven to desired temperature. Make sure there is a minimum of two inches (5cm) for heat circulation between pans and between pans and oven sides.

SECRETS TO SUCCESSFUL DOUGHMAKING

Select Highest Speed — When doughmaking, ALWAYS dial to highest speed as indicated on Mixing Guide.

Use 4-Quart Bowl — Use 4-quart (4L) Mixer Bowl when preparing 2-loaf yeast doughs. Also, use your Doughmaker for mixing meat loaves, quick breads such as muffins, corn bread, using either your 1 S-quart (1.5L) or 4-quart (4L) mixer bowl, depending on quantity.

Test for Doneness — Bread is done if the loaf sounds hollow when tapped lightly, is golden brown and well rounded. Remove from pan and immediately cool on wire rack.

High Altitudes — High altitudes make breads rise faster and higher. In altitudes of 5,000 feet (1,520 meters) or above, use 1 package active dry yeast when two are called for. In recipes calling for 1 package, test for double in size in second rising and bake even though it may not be quite doubled.

Use Tested Recipes or Family Favorites — The yeast bread recipes in this book have been especially developed for use with this unit. Adapt your own favorite recipes by following our method and making sure total flour capacity does not exceed 7 cups (1.75L).

As a general rule, to prepare a P-loaf recipe a total of 7 minutes is necessary to mix and thoroughly knead dough to a smooth and satiny consistency.

SALAD MAKER



IMPORTANT SAFEGUARDS

When using electrical appliances, the safety precautions in the General Important Safeguards section and the following safety precautions should always be followed.

1. Read all instructions.
2. Never feed food by hand. Always use food pusher.
3. Avoid contacting moving parts. Keep fingers and utensils out of food discharge area. If food becomes clogged, turn salad maker "OFF" and unplug from outlet before clearing obstructions.
4. Blades are sharp. Handle carefully.

SAVE THESE INSTRUCTIONS

NOTE: Salad Maker Not Included With All Models.

ASSEMBLING YOUR SALAD MAKER

After unpacking, disassemble unit before using first time. Refer to "How to Disassemble" for directions.

Wash all parts except adaptor and motor base in warm, soapy water. Rinse and dry immediately. **DO NOT PUT ANY PARTS IN AUTOMATIC DISHWASHER. DO NOT IMMERSER ADAPTOR OR MOTOR BASE IN WATER.**

ASSEMBLY

1. Position adaptor base on motor base by lining up "slots" on adaptor base with pivot pins on motor base. Seat firmly.
2. Place bowl on adaptor and turn counterclockwise until slots on bowl interlock with notches on adaptor base.
3. Place slinger into bowl, positioning center hole over driver.
4. Place desired cutting disc into position on driver.
5. Place cover on bowl, lining up notches. Push down and turn counterclockwise until cover interlocks on bowl. Cover and food discharge chute will meet.
6. Select proper pusher.
7. Unit is now assembled for proper operation.

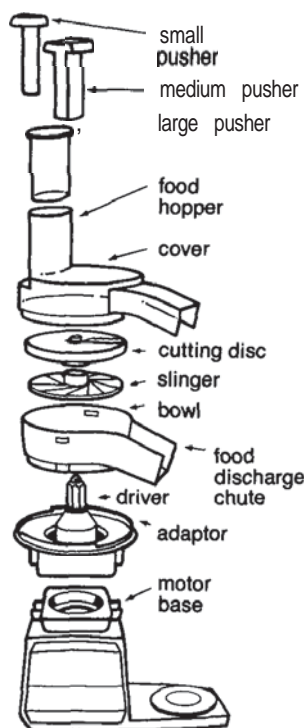

OPERATING THE SALAD MAKER

NOTE: This unit is designed with a safety interlock. Refer to "Maintenance Instructions" for proper operation of safety interlock.

1. Place large **4-quart (4-liter)** mixing bowl under food discharge chute.
2. Turn Control Dial to recommended speed as indicated on Food Processing Chart.
3. Place food into hopper.
4. Push "ON" button to start processing operation. Many foods will self-feed and need only to be guided by pusher. **DO NOT** use excessive pressure on food pusher. **DO NOT** put hands in food hopper or discharge chute at any time. If unit at any time seems to labor, push "OFF" button and clear of any obstructions.
5. To momentarily stop the salad maker, press "OFF" button. To start motor again, press "ON" button.
6. When processing is complete, push "OFF" button.

SALAD MAKER

HOW TO DISASSEMBLE

1. Remove pusher. Turn cover clockwise, lift and remove.
2. Lift cutting disc from driver.
3. Lift slinger and remove.
4. Turn bowl clockwise to unlock from adaptor base. Lift and remove.
5. Lift adaptor base from motor base.

CLEANING

DO NOT IMMERSE ADAPTOR IN WATER. Wash all other parts in warm, soapy water. Rinse and dry parts immediately. DO NOT PUT INTO AUTOMATIC DISHWASHER

REMOVE STAINS caused by processing large amounts of carrots or similar vegetables with baking soda or a liquid, mild abrasive cleaner. Rinse stained parts in water and sprinkle with baking soda; rub with a soft, damp cloth. Rinse.

MAINTENANCE

This unit is designed with a safety interlock. The interlock requires that the cover be in place before the cutting disc will rotate. (The interlock does not control operation of the motor.) To insure that the interlock is operating correctly, place only the adaptor on the motor base. Operate the motor base. The driver should not turn. If it does turn, DO NOT USE. Return the unit to an authorized Oster service facility for repair. DO NOT USE THE INTERLOCK FEATURE AS A SUBSTITUTE for turning unit "OFF" and unplugging the unit before disassembly and cleaning.

ANY OTHER SERVICING REQUIRED SHOULD BE PERFORMED BY AN AUTHORIZED OSTER SERVICE FACILITY.

PUSHER SELECTION

Use LARGE PUSHER when processing a full hopper of food. ALWAYS REMOVE SMALL AND MEDIUM PUSHERS WHEN USING LARGE PUSHER.

Use small and medium pushers together to process single quantities of food, such as a carrot, stalk of celery or a small cucumber. One of the pushers will act as a spacer to keep the single piece of food vertical within the remaining hopper space. ALWAYS PLACE THE SPACER PUSHER ON THE SIDE OF THE HOPPER WITH THE RIBBED TOP EDGE. Always place the food toward the clear side of the hopper. Use the remaining pusher to feed the food into the cutting disc.

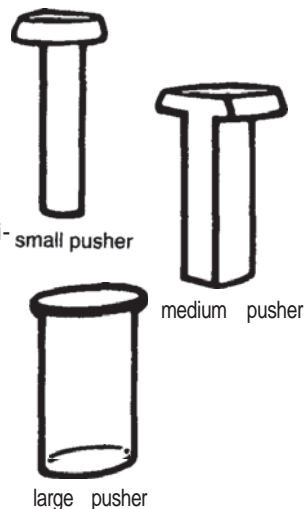

SALAD MAKING HINTS

CUTTING DISC USES

SHREDDER DISC

Bread crumbs for toppings, meat loaves, etc., cracker crumbs for pie crusts, shredded hard cheeses for pizza, Italian dishes, etc., chopped nuts for dessert topping, nut breads, cakes and cookies, hard-cooked egg garnishes and spreads, potatoes for hash browns and pancakes, vegetables for salads, cakes and breads. Model 937-84



shredder

SLICING DISC

Bread and butter pickles, vegetables for soup, stews and casseroles, fruits for pies and cobblers, fruit and vegetables for freezing and canning, vegetables for dips and dunks. Model 937-81

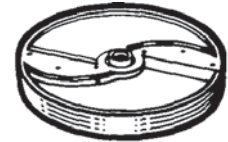

slicing

FRENCH FRY DISC

Raw potatoes for fries, fresh zucchini for salads and stir-fry, celery and onion for a diced texture for use in casseroles, salads and poultry stuffings, cooked beets, fresh or canned, for use in salads, hot or cold vegetable dishes. Model 937-85

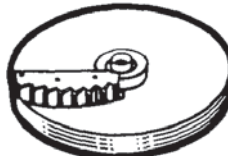

french fry

TIPS

1. To insure even, uniform slices, CUT LONG, NARROW vegetables in uniform lengths, approximately the length of the food pusher, for easy packing and slicing.
2. When using large pusher, PACK FOOD HOPPER firmly when slicing any long, narrow foods such as celery, carrots, small zucchini or small cucumbers.
3. SHRED ONLY refrigerator-cold Mozzarella or Swiss cheeses for best results.
4. PROCESS ONLY firm fruits and vegetables for best results.
5. Large pusher is also a measuring cup.
6. DO NOT PROCESS: Dates and Dried Fruits, Processed Cheese, Meats-raw or cooked, Tomatoes, Green Onions, Soft Cheddar Cheese, Citrus Fruits and Rind.



1 YEAR LIMITED WARRANTY

Sunbeam-Oster Household Products warrants that, for a period of one year from date of purchase, this product shall be free of mechanical and electrical defects in material and workmanship. Our obligation hereunder is limited to repair or replacement, at our option, of this product during the warranty period, provided the product is sent postage prepaid directly to our factory service center:

SUNBEAM-OSTER HOUSEHOLD PRODUCTS
APPLIANCE SERVICE STATION
117 Industrial Central Row
Purvis, MS 39475

DO NOT RETURN THIS PRODUCT TO THE PLACE OF PURCHASE; ACTING OTHERWISE MAY DELAY THE PROCESSING OF YOUR WARRANTY CLAIM. This warranty does not cover normal wear of parts, damage resulting from any of the following: negligent use or misuse of the product, use on improper voltage or current, use contrary to operating instructions, or disassembly, repair, or alteration by any person other than our factory service center. Product repair or replacement as provided under the above warranty is your exclusive remedy. Sunbeam Corporation (of which Sunbeam-Oster Household Products is a division), shall not be liable for any incidental or consequential damages for breach of any express or implied warranty on this product. Except to the extent prohibited by applicable law, any implied warranty of merchantability or fitness for a particular purpose on this product is limited in duration to the duration of the above warranty. Some states do not allow the exclusion or limitation of incidental or consequential damages, or allow limitations on how long an implied warranty lasts, so the above limitations or exclusion may not apply to you. This warranty gives you specific legal rights, and you may also have other rights which vary from state to state.

Sunbeam and Oster are registered trademarks of Sunbeam-Oster Company, Inc. or its affiliated companies.
© 1993 Sunbeam-Oster Company, Inc. or its affiliated companies. All rights reserved.

PRINTED IN USA

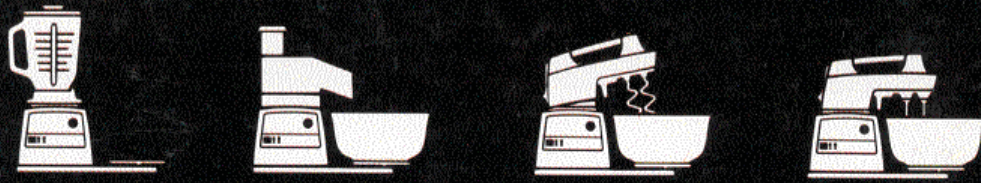

Oster[®]

1994 SUNBEAM-OSTER HOUSEHOLD PRODUCTS
SCHAUMBURG, IL 60173

© 1994 Sunbeam-Oster Company, Inc., or its affiliated companies. All rights reserved.
Sunbeam[®], Oster[®], Kitchen Center[®] and Osterizer[®] are registered trademarks of
Sunbeam-Oster Company, Inc., or its affiliated companies.

26322-10

LITHO IN U.S.A.

Foodcrafter[™], Controlled Power[™] and Quick-Freeze[™] are trademarks of
Sunbeam-Oster Company, Inc., or its affiliated companies.