



KMÜ 407

ANALYSIS AND TESTING OF POLYMERS

Outline

1. CHEMICAL ANALYSIS OF POLYMERS
2. SPECTROSCOPIC ANALYSIS OF POLYMERS
3. X-RAY DIFFRACTION ANALYSIS
4. MICROSCOPY
5. THERMAL ANALYSIS
6. PHYSICAL TESTING
7. PROJECT DESCRIPTION
8. OUR DEPARTMENT'S ANALYSIS LABORATORY EQUIPMENTS FOR POLYMER TESTING

1. CHEMICAL ANALYSIS OF POLYMERS

- Structural analysis and the study of degradation properties are important in order to understand and improve performance characteristics of synthetic polymers and copolymers in many industrial applications.
- The chemical analysis of polymers is not basically different from the analysis of low-molecular-weight organic compounds, provided that appropriate modification is made to ensure solubility or the availability of sites for reaction (e.g., insoluble specimens should be ground to expose a large surface area).
- Two powerful techniques for chemical analysis of polymers:
 - Mass Spectrometry
 - Gas Chromatography

Mass Spectrometry

- In the most common applications of mass spectrometry to polymer systems, the polymer is allowed to react to form low-molecular-weight fragments that are condensed at liquid-air temperature.
- They are then volatilized, ionized, and separated according to mass and charge by the action of electric and magnetic fields in a typical mass spectrometer analysis.
- From the abundance of the various ionic species found, the structures of the low-molecular-weight species can be inferred.

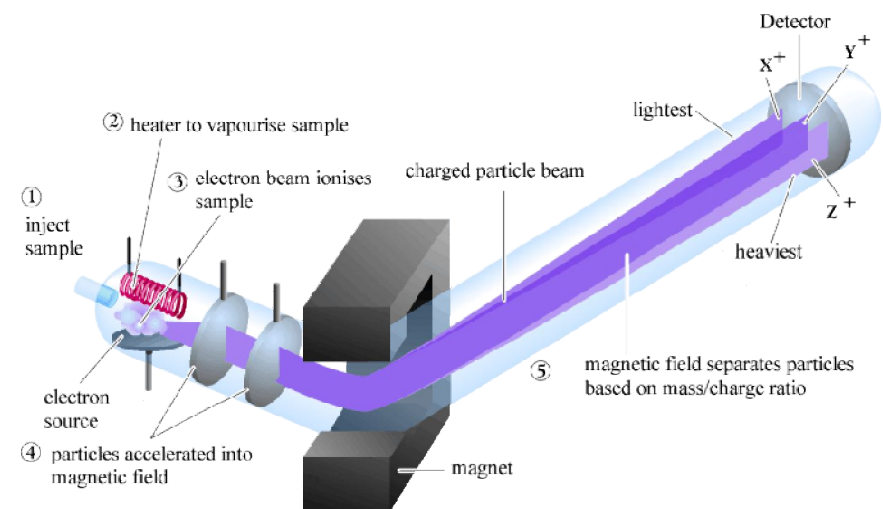

Mass Spectrometry

A mass spectrum will usually be presented as a vertical bar graph, in which each bar represents an ion having a specific mass-to-charge ratio (m/z) and the length of the bar indicates the relative abundance of the ion.

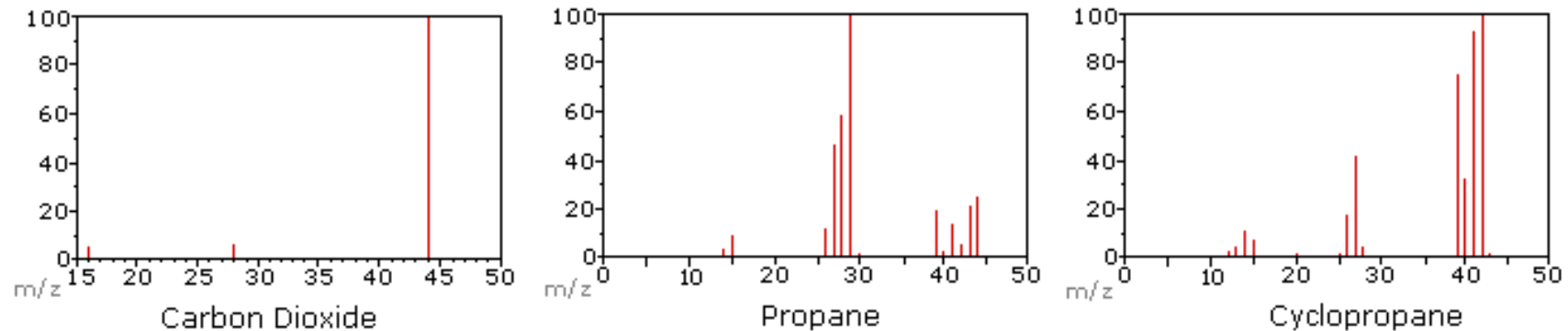

The measurement efficiency for a given polymeric species in a distribution depends on a number of factors, including:

- the efficiency of dissolving the sample in the matrix,
- sample vaporization,
- ionization,
- ion transmission and
- finally detection.

Developments in high resolution mass spectrometers have additionally led to impressive advances in our ability to characterize polymers.

- The entire molecular mass distribution of a polymer sample can be accurately measured.
- From the molecular mass, the molecular formulae and information regarding polymer composition and end-groups can be deduced.
- However, the difficulty in applying this technique to polymers has been volatilizing high molecular mass polymeric ions without fragmentation.
- Soft ionization mass spectrometry, in which only intact molecular ions are observed with minimal fragmentation, affords both the chain length distribution and the chemical composition at every chain length, which may be deduced from the mass.

Mass Spectrometry

- For polymers with molecular weights exceeding a million Da, polymers were ionized using matrix-assisted laser desorption/ionization (MALDI) and the ions were mass separated on a time-of-flight (TOF) analyzer.
- The most successful high molecular mass characterization in which 10^8 Da DNA strands were ionized using electrospray ionization (ESI).
- In addition to MALDI and ESI there are a variety of analytical mass spectrometric methods currently available which furnish intact molecular ions from polymeric materials up to about 5000 Da.

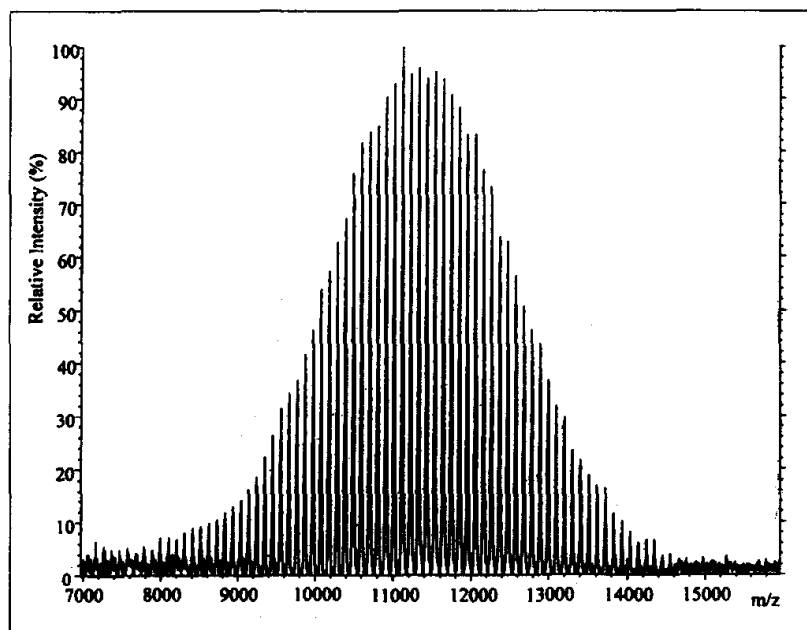

MALDI-TOF time-lag focusing spectrum of polystyrene sample showing baseline resolution of oligomers.

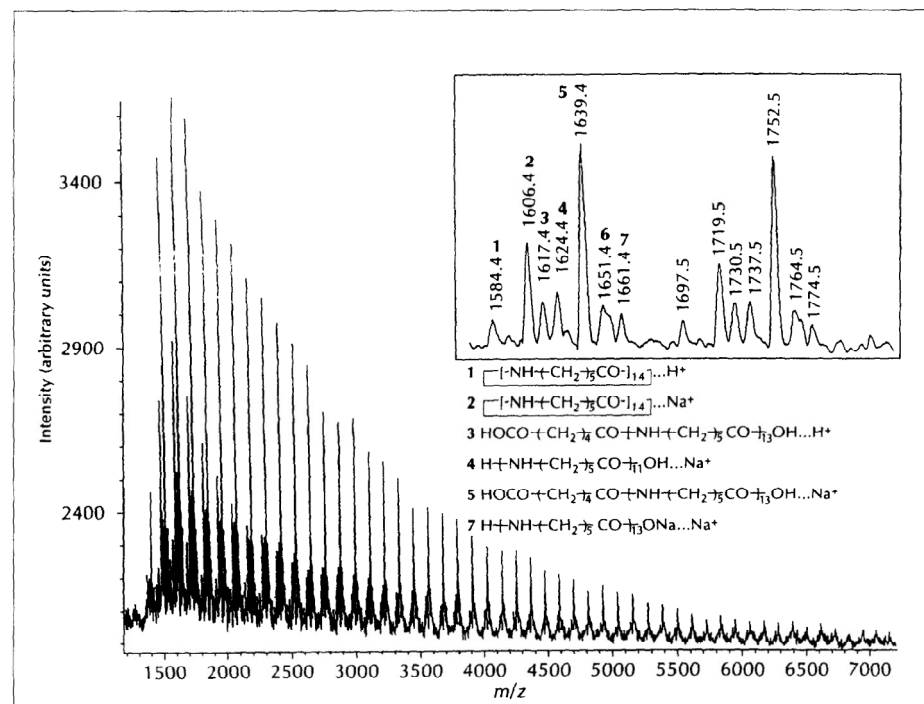

MALDI-TOF mass spectrum of nylon-6 reacted with adipic acid. The expanded spectrum in the inset shows the peaks corresponding to cyclic (peaks 1 and 2), dicarboxy-terminate (peaks 3 and 5) and amino- and carboxy-terminated (peaks 4 and 7) chains. Peak 6 was not identified.

Gas Chromatography

- Gas chromatography (GC) is a method of separation in which gaseous or vaporized components are distributed between a moving gas phase and a fixed liquid phase or solid adsorbent.
- By a continuous succession of adsorption or elution steps, taking place at a specific rate for each component, separation is achieved.
- The components are detected by one of several methods as they emerge successively from the chromatographic column.
- As polymers are non-volatile under the usual conditions used in GC, this technique is used for analyzing the volatile products of the degradation of high molecular weight compounds, rather than the polymers themselves.

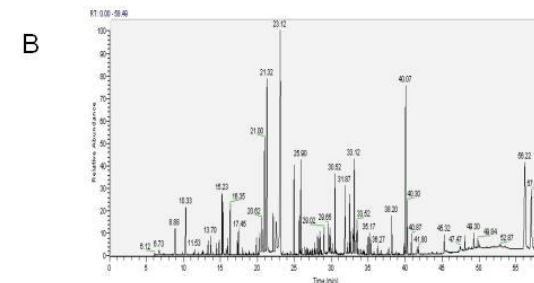
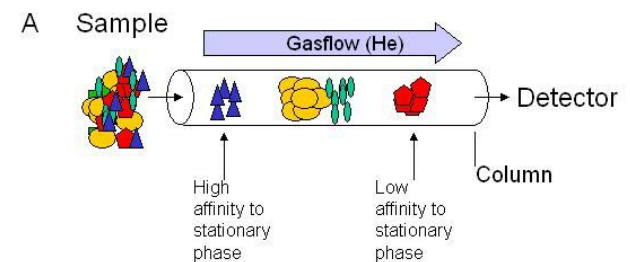

- Polymers/copolymers cannot be analyzed in their normal state by traditional (GC) because of high molecular weight and lack of volatility.
- In recent years, some work has shown that it is possible, in theory, to analyze polymers by GC with the use of high pressure carrier gas.

Reaction GC:

- For functional group analysis of polymers, chemical reactions are combined with GC.
- If polymer is insoluble, method can be applied to determine surface functional groups only.

GASOMETRIC DETERMINATION OF ORGANIC FUNCTIONAL GROUPS

Functional group	Principle of determination	Compound analyzed
Azo	Heating with phenylhydrazine	Nitrogen
Alkene	Catalytic hydrogenation and determination of absorbed hydrogen	Hydrogen
Alkyl nitrate	Reduction	Nitrogen oxides
Alkoxy	Formation of alkyl iodide, oxidation and reaction of iodic acid with hydrazine	Nitrogen
Amide and imide	Reaction with Grignard reagent	Methane
Amine	Nitrosation	Nitrogen
Hydrazine and hydrazide	Oxidation	Nitrogen
Hydroxyl	Reaction with lithium aluminium hydride	Hydrogen
Diazo	Heating in the presence of catalyst	Nitrogen
Carboxyl	Decarboxylation with Grignard reagent	Carbon monoxide Methane
Carbonyl	Reaction with Grignard reagent and decomposition of excess of reagent	Methane
	Reduction with sodium borohydride and determination of excess of reagent	Hydrogen
N-Nitro	Reaction with sulphuric acid and mercury	Nitrogen oxides
N-Nitroso	Reduction	Nitrogen
	Reaction with sulphuric acid and mercury	Nitric oxide
Semicarbazide	Oxidation	Nitrogen
Ester	Reaction with Grignard reagent and decomposition of excess of reagent	Methane
	Reduction with lithium aluminium hydride and decomposition of excess of reagent	Hydrogen
Sulphamide	Oxidation with nitric acid	Nitrogen dioxide

Pyrolysis GC:

- By heating polymers to temperatures above 500 °C, they are pyrolyzed into many individual fragmentation substances, which can be then separated chromatographically and identified by mass spectrometry.
- Pyrolysis methods eliminate the need for pre-treatment by performing analyses directly on the solid polymer/copolymer sample.
- A large molecule will break apart and rearrange in a characteristic way. If the energy transfer to the sample is controlled by temperature, heating-rate and time, the fragmentation pattern is reproducible and characteristic for the original polymer.

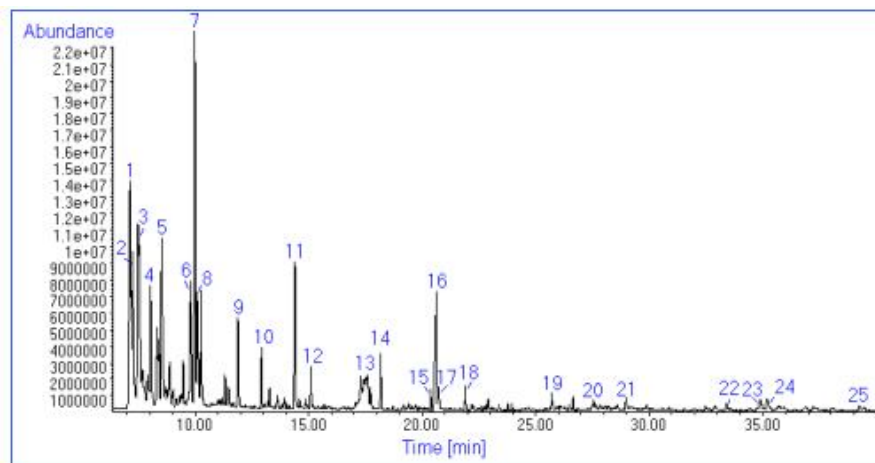

Pyrolysis–GC/MS chromatogram of a plastic sample pyrolyzed at 600 °C, identified as flexible poly(vinyl chloride) (PVC)

Peak	Retention time (RT) [min]	Pyrolysis products of polyvinyl chloride (PVC) with DEHP plasticizer at 600 °C
1	7.14	Hydrochloride/Propene
2	7.25	1-Butene
3	7.49	1,4-Pentadiene
4	8.05	2,4-Hexadiene
5	8.53	Benzene
6	9.81	Toluene
7	9.98	2-Ethyl-1-hexene
8	10.09	3-Methyl-3-heptene
9	11.89	Styrene
10	12.93	2-Ethylhexanal
11	14.40	2-Ethyl-1-hexanol
12	15.10	Indene
13	17.57	Benzoic acid
14	18.18	Naphthalene
15	20.38	2-Methylnaphthalene
16	20.63	Phthalic anhydride
17	20.73	1-Methylnaphthalene
18	21.91	Biphenyl
19	25.71	Fluorene
20	27.56	1,2-Diphenylethylene
21	28.97	Anthracene
22	33.45	Fluoranthene
23	34.89	Benzofluorene isomer
24	35.19	Benzofluorene isomer
25	39.35	Benz[a]anthracene



2. SPECTROSCOPIC ANALYSIS OF POLYMERS

- Infrared Spectroscopy
- Nuclear Magnetic Resonance Spectroscopy
- Electron Paramagnetic Resonance Spectroscopy

2. SPECTROSCOPIC ANALYSIS OF POLYMERS

Infrared Spectroscopy

The energy difference between two quantum states of a molecule is related to the frequency of the radiation emitted or absorbed.

$$\Delta E = h\nu$$

Infrared frequencies in the wavelength range 1-50 μm are associated with molecular vibration and vibration-rotation spectra.

A molecule containing N atoms has $3N$ normal vibration modes, including rotational and translational motions of the entire molecule. Even for the most low molecular-weight substances, N is too large for such analysis.

In polymers the infrared absorption spectrum is often surprisingly simple, if one considers the large number of atoms involved.

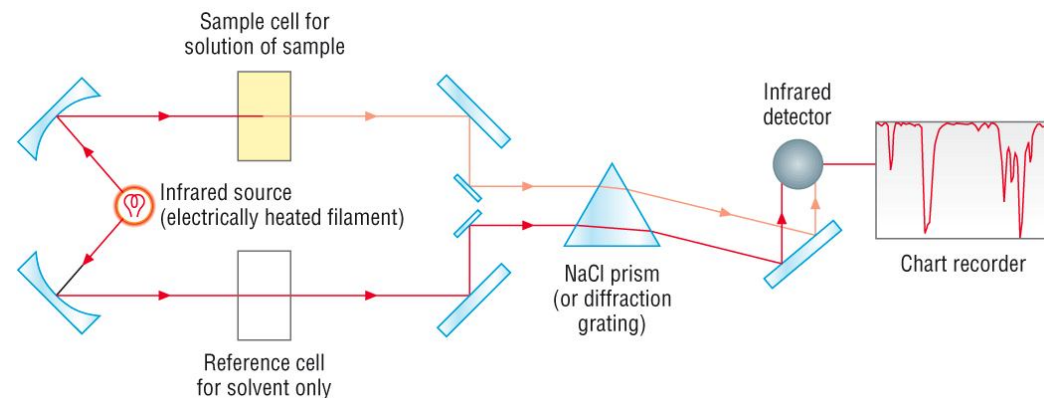
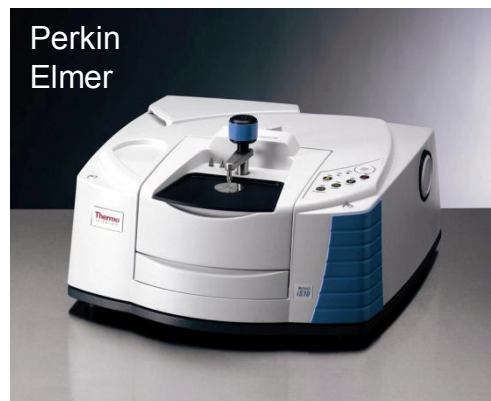

Infrared Spectroscopy

Infrared (IR) spectroscopy is ideally suited to qualitative analysis of polymer starting materials and finished products as well as to quantification of components in polymer mixtures and to analysis of in-process samples.

- Detection of chemical groups
 - Dichroism
 - Crystallinity
 - Geometric isomerism
- The IR spectrum derives from absorption of light exciting molecular vibrations.
 - The positions of absorption bands in the spectrum give information about the presence or absence of specific functional groups in a molecule.
 - As a whole the spectrum constitutes a “fingerprint” that can be used to determine the identity of the sample.

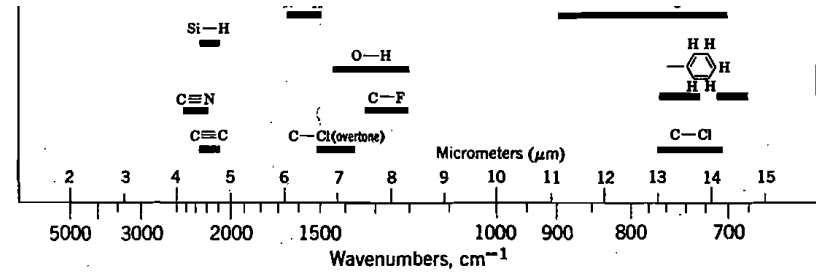

i. 9-1: Infrared absorption bands of interest in polymers arranged by approximate wavelength frequency.

ferent, information from Raman experiments in general supplements that nable from infrared absorption. Utilization of lasers as light sources has gre: reased experimental difficulties in this technique, and the method has r: ome one of the standard tools for polymer analysis (Hendra 1969, Koenig 197

chroism. For any molecular vibration leading to infrared absorption, ther: eriodic change in electric dipole moment. If the direction of this chang

Infrared absorption bands of interest in polymers arranged by approximate wavelength and frequency

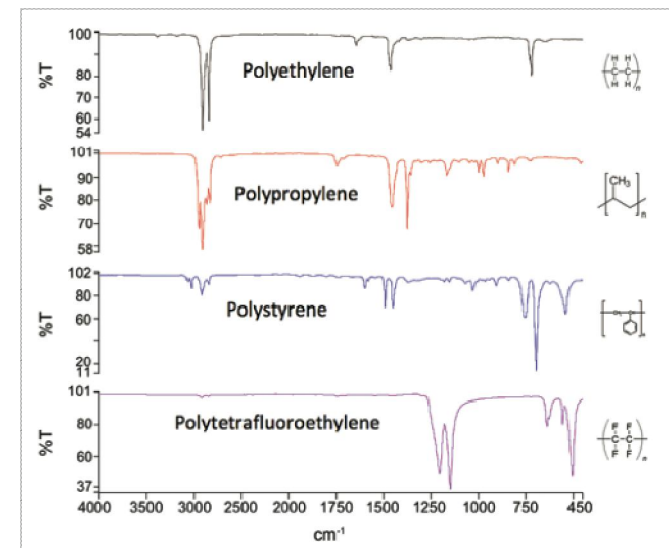

Mid-IR spectra of common polymers

Dichroism:

- Infrared linear dichroism has been a useful tool for studying the conformation and orientation of polymer molecules in deformed samples.
- When a polymer film is drawn, the macromolecular chains tend to align in a specific direction. The oriented film may then absorb, to different extents, incident infrared radiation polarized parallel and perpendicular to a reference direction usually defined as the draw direction.
- When a sample film absorbs more parallel than perpendicular light, the dichroic difference is positive and the dichroic ratio is greater than one.
- Dichroic ratios depend upon both the degree of orientation and the angle between the direction of the transition moment and the selected direction in the sample (for example, the axial direction in a fiber). They usually range between 0.1 and 1.0.
- The dichroic ratio has traditionally been used to aid in the assigning of infrared bands to specific vibrational modes and to help determine the molecular chain orientation.

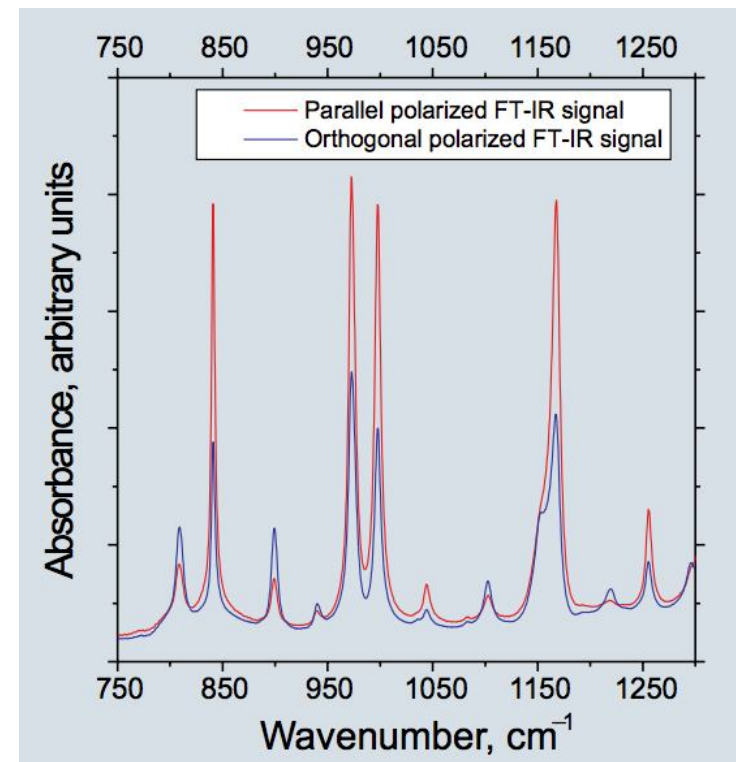

Polarized FT-IR spectra from an iPP sample

Crystallinity:

The infrared absorption spectra of the same polymer in the crystalline and amorphous states can differ for at least two reasons:

1. Specific intermolecular interactions may exist in the crystalline polymer that lead to sharpening or splitting of certain bands
2. Some specific conformations may exist in one but not the other phase, leading to bands characteristic exclusively of either crystalline or amorphous material.

Geometric isomerism:

The determination of the various types of geometric isomers associated with unsaturation in polymer chains is of great importance. However, it is more difficult to distinguish between the cis and trans configurations.

OPIC METHODS

but not the other phase, leading to bands characteristic of crystalline or amorphous material. An example of the latter effect is polyethylene terephthalate (PET), in which the $-\text{OCH}_2\text{CH}_2\text{O}-$ portion of each repeat unit can exist in two different conformations in the crystal, but can exist in part in the amorphous phase. Several bands characteristic of each conformation have been identified.

Sample Preparation:

One of the greatest experimental difficulties in work with substances that absorb heavily in the infrared, including many polymers, is obtaining sufficiently thin samples. Common methods of sample preparation include the following:

- Compression molding, by far the most widely used preparation technique,
- Dissolving the polymer in a solvent, such as carbon disulfide or tetrachloroethylene, whose spectrum is relatively free of intense absorption bands
- Casting a thin film from solution
- Preparing a thin film by microtoming or milling,
- Pressing a finely ground mixture of the sample with KBr to form a disc or wafer.
- Transmission measurements require a short path length,
- Attenuated total reflectance (ATR), in which the sample is pressed against a diamond, zinc selenide or germanium crystal and the absorption of the evanescent wave is measured. This technique requires little to no sample preparation and very reliably produces high quality spectra.
- Diffuse reflectance (DRIFT) is a useful technique where the sample is physically too large to measure with ATR and a sample can be taken by abrasion.

Table 1. Sampling techniques for FT-IR spectroscopy of polymers.

Sample Form	Suitable Techniques
Thin films (<25 μm)	Transmission
Fine powders (<2 μm)	Transmission (KBr), ATR, DRIFT
Large items	DRIFT (abrasive sampling)
Irregular shapes, pellets	ATR, DRIFT (abrasive sampling)
Polymers soluble in volatile solvents	Transmission (cast film)
Flat, reflective surfaces	Specular reflectance, ATR, DRIFT (abrasive sampling)
Single fibers	Diamond ATR or IR microscope

2. SPECTROSCOPIC ANALYSIS OF POLYMERS

Nuclear Magnetic Resonance Spectroscopy

Since about 1960 nuclear magnetic resonance (NMR) spectroscopy has become a major tool for the study of chain configuration, sequence distribution, and micro-structure in polymers.

Its use has evolved from early broad-line studies of the onset of molecular motion in solid polymers, through the widely practiced solution studies of proton NMR, to the application of the more difficult but more powerful carbon-13 NMR methods to both liquids and solids.

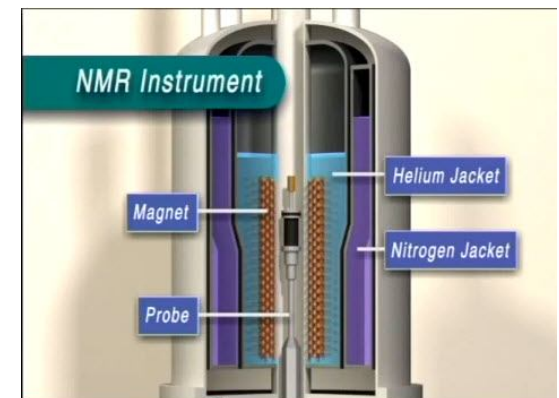
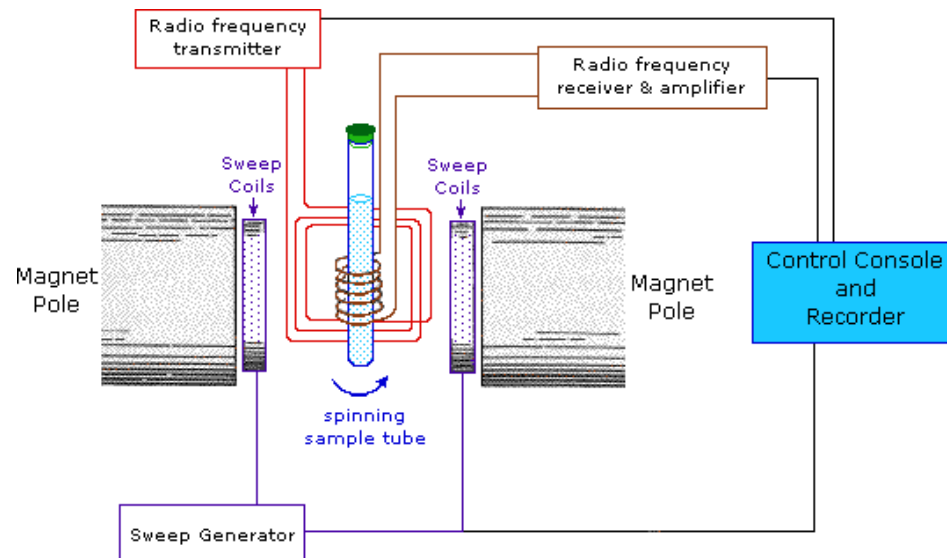

Nuclear Magnetic Resonance Spectroscopy

- The NMR technique utilizes the property of spin possessed by nuclei whose atomic number and mass number are not both even.
- Such nuclei include the isotopes of hydrogen and ^{13}C , ^{15}N , ^{17}O , and ^{19}P .
- Application of a strong magnetic field to material containing such nuclei splits the energy level into two, representing states with spin parallel and anti parallel to the field.
- The energy transfer takes place at a wavelength that corresponds to radio frequencies and when the spin returns to its base level, energy is emitted at the same frequency.
- The resonant frequency of the energy transition is dependent on
 - The effective magnetic field at the nucleus
 - The chemical environment (the more electronegative the nucleus is, the higher the resonant frequency)
- As a result, information about the nucleus' chemical environment can be derived from its resonant frequency (It is customary to adopt tetramethylsilane (TMS) as the proton reference frequency).
- The displacements in the resonances, called *chemical shifts*, are measured in ppm in frequency (or the equivalent field strength) on a scale labeled δ (Reference point: $\delta=0$).

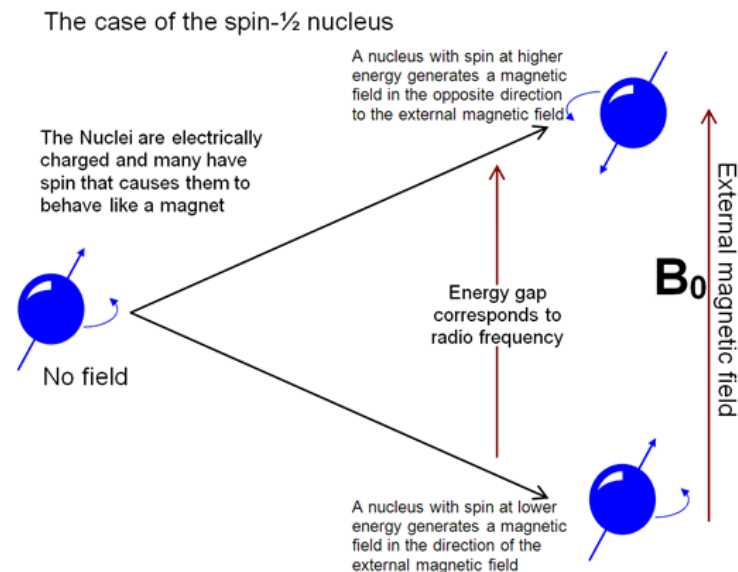

Stereochemical configuration:

On a high field NMR instrument, the chemical shift of the methyl groups on the polymer backbone is sensitive to the relative stereochemistry of its four nearest neighbors (two on each side).

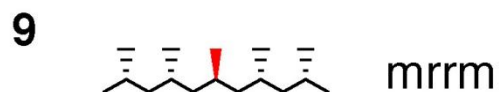
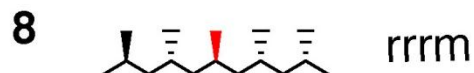
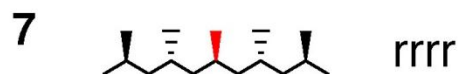
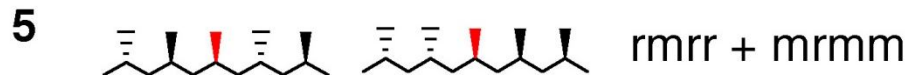
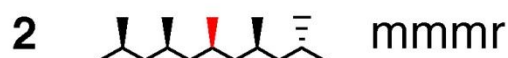
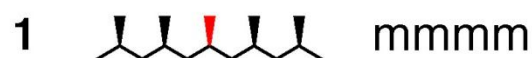

m = *meso* (*syn*) r = *racemo* (*anti*)

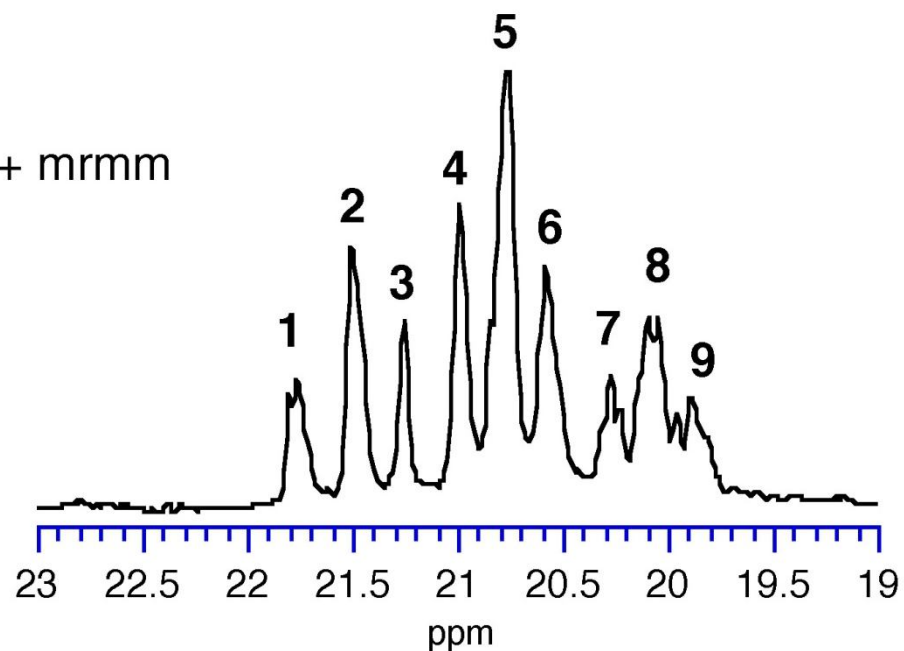

Nuclear Magnetic Resonance Spectroscopy

Geometric isomerism:

Both proton and ^{13}C NMR are very useful determining isomerism around the carbon-carbon bond in polymer chains.

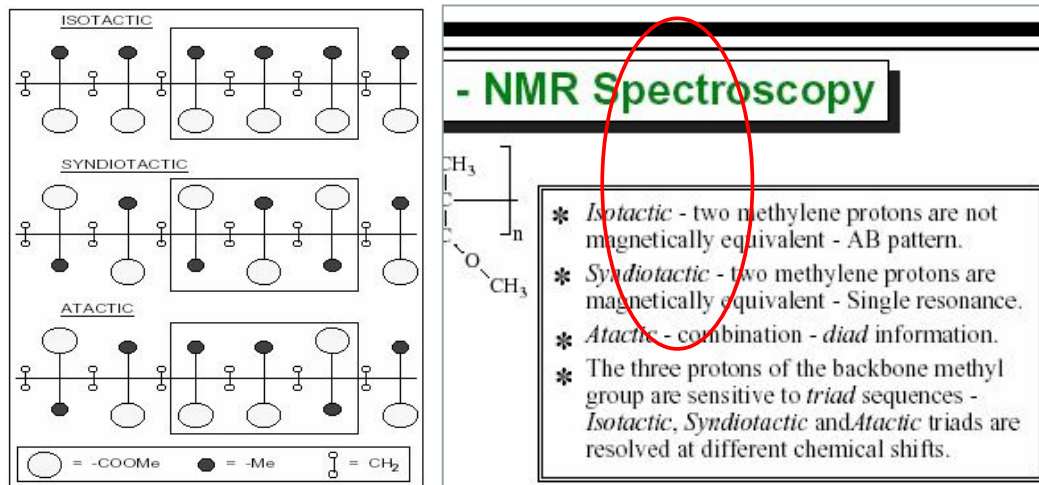

IR Spectroscopy

- * *Isotactic* - two methylene protons are not magnetically equivalent - AB pattern.
- * *Syndiotactic* - two methylene protons are magnetically equivalent - Single resonance.

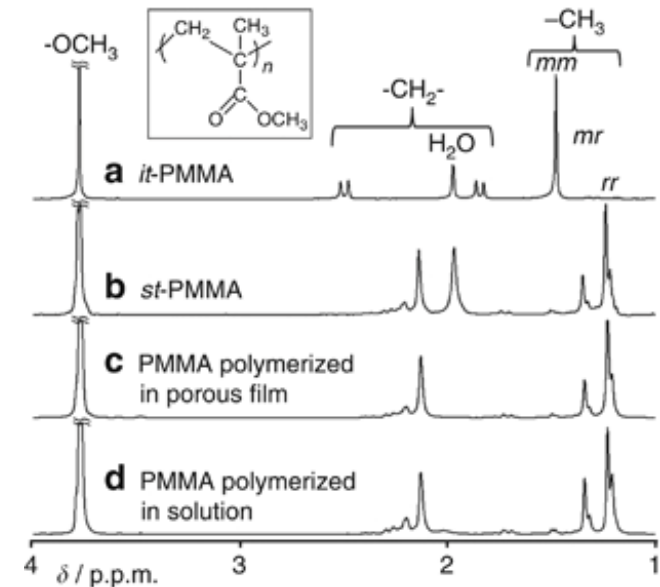

^1H NMR spectra of poly(methyl methacrylate). These samples were measured in nitrobenzene- d_5 at 110 °C (400 MHz).

Nuclear Magnetic Resonance Spectroscopy

Copolymer sequences:

The principles of analyzing short sequences of monomers in a copolymer are not different from those of determining stereochemical configuration.

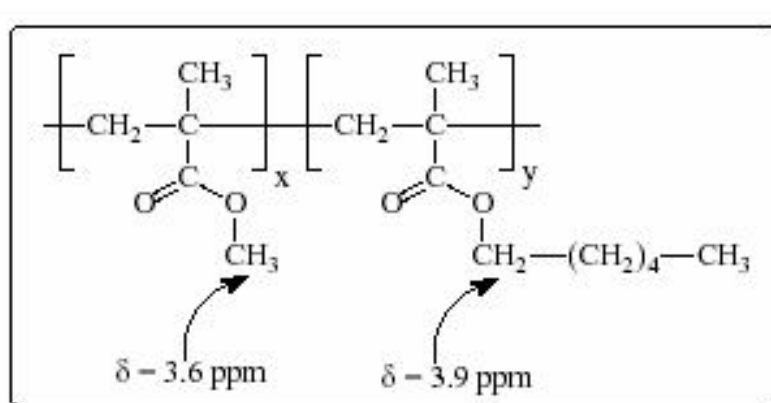

MMA-co-HMA

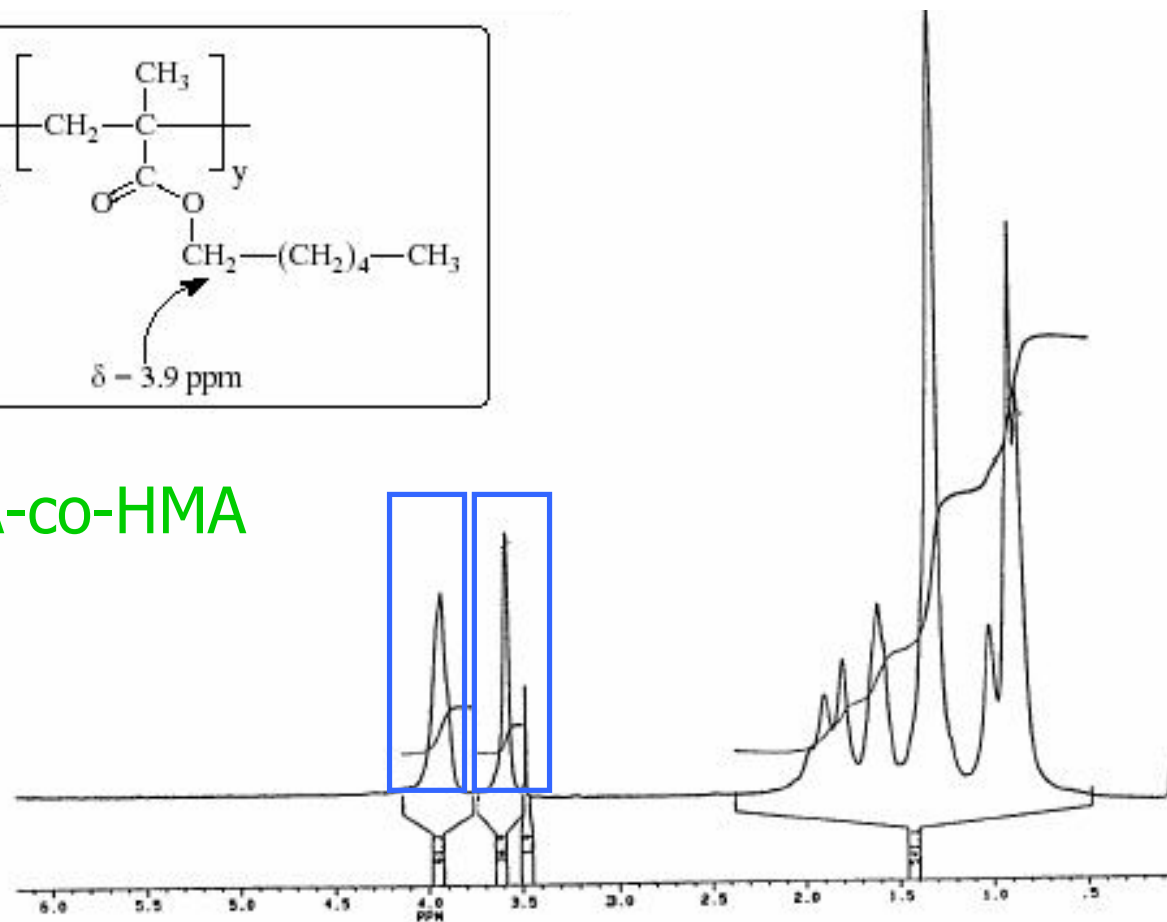

Proton NMR spectrum of a copolymer of methyl methacrylate and hexyl methacrylate

Molecular weight determination:

Once the ratio of protons on the end-groups to protons on the polymer chain is determined, using the NMR, simple math can be applied to generate the Mn value.

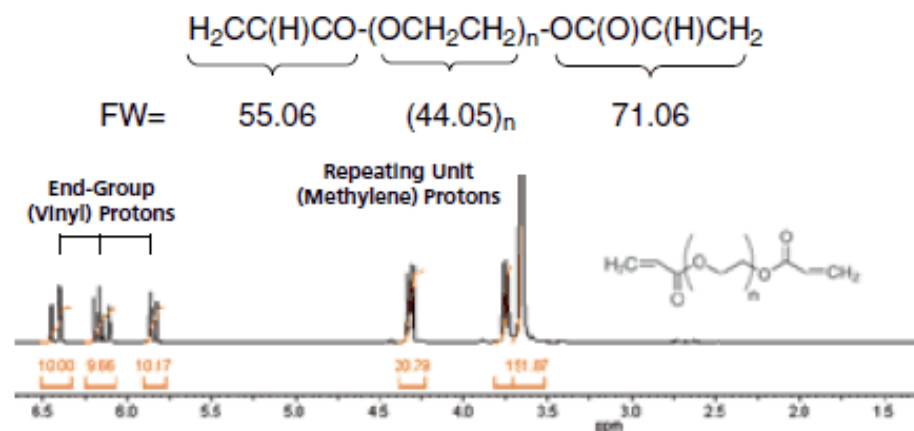

NMR spectra of poly (ethylene glycol) diacrylate

1) Calculation, integral per proton:

Locate the end-group proton signals (ca. 5.8, 6.2 & 6.4 ppm) integral per proton = sum of vinyl proton integrals/# of protons in the two vinyl end groups $(10.00 + 9.66 + 10.17)/6 = 4.97$ per proton

2) Calculation, number of repeating monomer units, n:

Locate the OCH₂CH₂ proton signals (ca. 3.6, 3.7 & 4.3 ppm)

$n = ((\text{sum of CH}_2 \text{ proton integrals})/\# \text{ of CH}_2 \text{ protons})/\{\text{integral per proton value}\}$
 $((20.79 + 151.87)/4)/4.97 = 8.69$ repeating units, n;

3) Calculation, Mn:

$M_n = (\text{FW end groups}) + (\text{FW repeating unit})(n)$
 $= (55.06 + 71.60) + (44.05)(8.69) = 509$;

Therefore, the Mn of this polymer is approx. 509

Nuclear Magnetic Resonance Spectroscopy

- In proton NMR, a coupling of the resonance lines, resulting in the splitting of their

- Experimental methods

- The use of high resolution compared to

- The use of constant frequency field collapsing method

- A great advantage is the wide range of chemical shifts. The intensity is proportional to chemical abundance

- The lower sensitivity of carbon nuclei in solution which a high-power pulse is used to excite carbon nuclei into the magnetic field

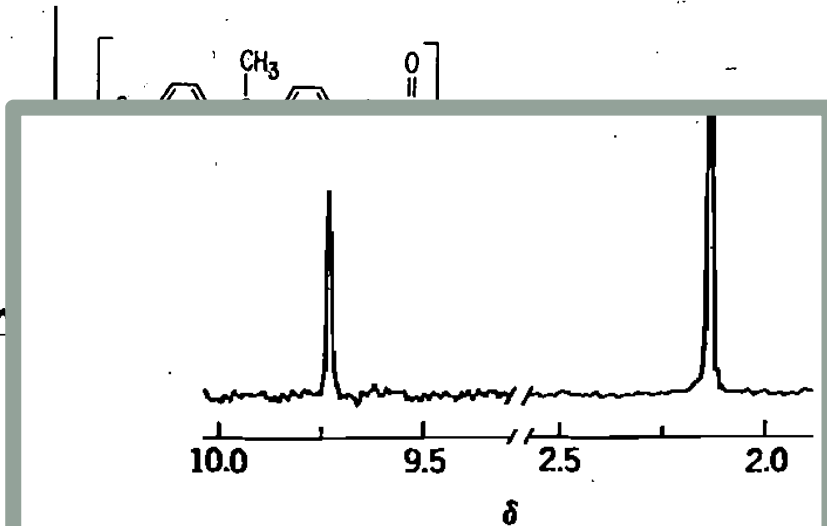

Spectra of propylene oxide in carbon tetrachloride solution: (top) double-resonance spectrum showing simplification resulting due to coupling (Bovey 1965).

summed by computer, which transforms the data. The signal-to-noise ratio has reached a satisfactory level. The study of molecular motion in solid polymers has been made possible by the theory of line broadening. It can be shown that the line width of like nuclei in a solid sample is given by an expression which is the chemical shift observed in solution plus a broadening term proportional to $\sin^2 \theta$, where θ is the angle between the

High-resolution NMR spectra of bisphenol-A polycarbonate in deuteriochloroform solution showing the effect of frequency on resolution (Sudol 1969).

on result from the same nucleus, resulting in the

100,000-220,000 gauss

is second radio frequency coupling and

greater range of chemical shifts due to the low

Fourier transform NMR, in which the energy sets all the nuclei and then sweep the frequency

Electron Paramagnetic Resonance Spectroscopy

- Although electron paramagnetic resonance (EPR) and NMR spectroscopy are similar in basic principles and in experimental techniques, they detect different phenomena and therefore yield different information.
- The major use of EPR spectroscopy lies in the detection of free radicals.
- These species are uniquely characterized by their magnetic moment, arising from the presence of an unpaired electron.
- Measurement of a magnetic property of a material containing free radicals, such as its magnetic susceptibility gives the concentration of free radicals, but the method lacks sensitivity and cannot reveal the structure of the radicals. Electron paramagnetic resonance spectroscopy is essentially free from these limitations.



Electron Paramagnetic Resonance Spectroscopy

- EPR detects the transitions of unpaired electrons in an applied magnetic field. Like a proton, the electron has “spin”, which gives it a magnetic property known as a magnetic moment.
- The magnetic moment makes the electron behave like a tiny bar magnet similar to one you might put on your refrigerator.
- When we supply an external magnetic field, the paramagnetic electrons can either orient in a direction parallel or antiparallel to the direction of the magnetic field. This creates two distinct energy levels for the unpaired electrons and allows us to measure them as they are driven between the two levels.

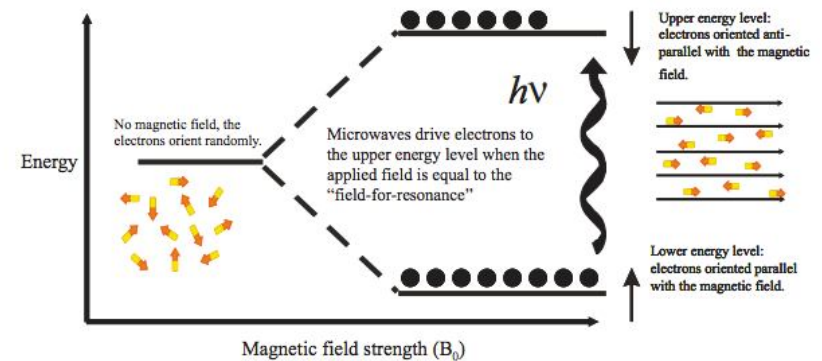

This technique is mainly used for the study of polymerization and degradation. In addition to these, EPR is used to characterize the charge transfers in conducting polymers.

Evidence from EPR spectrum of gamma-irradiated polystyrene gives support to the assumption that radicals in structure A are involved in the photolysis and photo-oxidation of polystyrene.

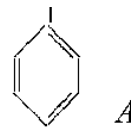

is and photo-oxidation of polystyrene *in vacuo* gives a three-line spectrum

N. GRASSIE
of detecting and identifying radicals in
reason of their low concentration, which
tivity. Concentrations can be increased
radicals and it is for this reason that a
e been carried out on radicals immobil
radicals are most readily formed in such a
ation and indeed we can discern the big
being closely associated with the intere
energy radiation which developed rapid
energy radiation became available ab
two strongly focused upon polymer

Electron spin resonance spectrum of polystyrene irradiated at 7 K and observed at 300 K

3. X-RAY DIFFRACTION ANALYSIS

The x-ray diffraction method is a powerful tool for investigating orderly arrangements of atoms or molecules through the interaction of electromagnetic radiation.

If the structures are arranged in an orderly array or lattice, the interferences are sharpened so that the radiation is scattered or diffracted only under specific experimental conditions.

The X-Ray Diffractometer (XRD) techniques had been used successfully from long time for the crystallographic study of polymers.

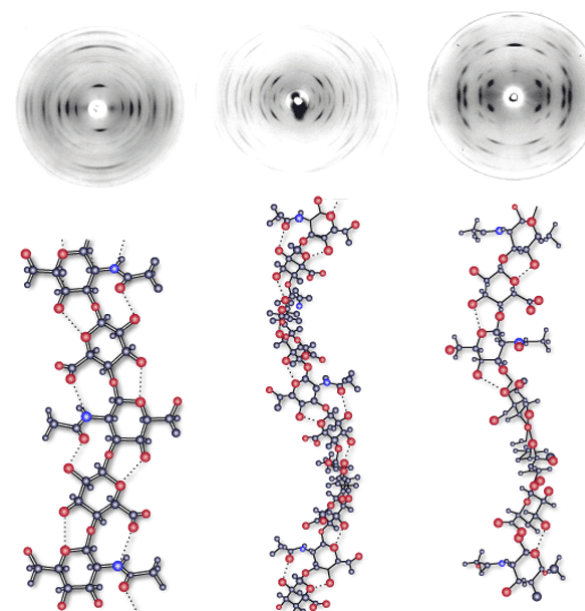
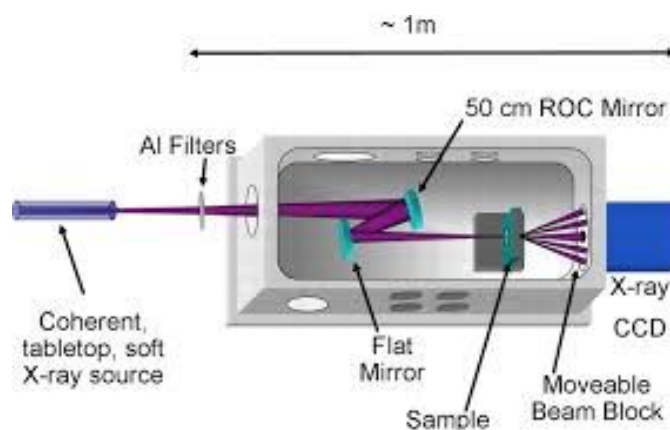

3. X-RAY DIFFRACTION ANALYSIS

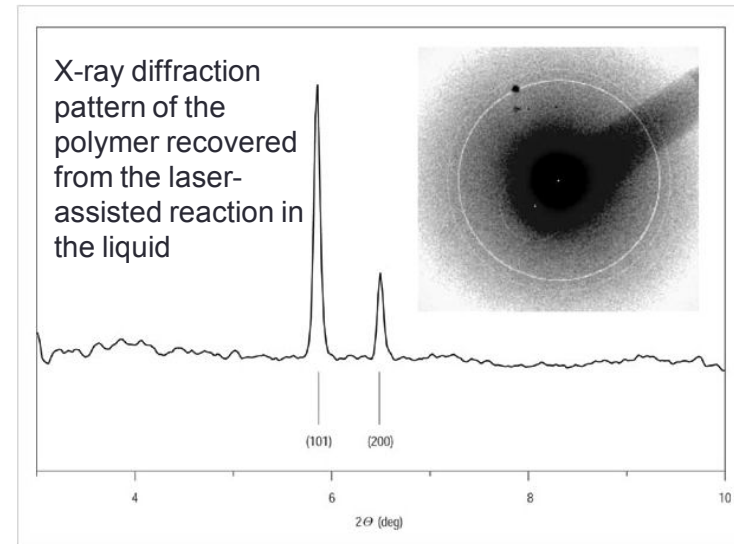
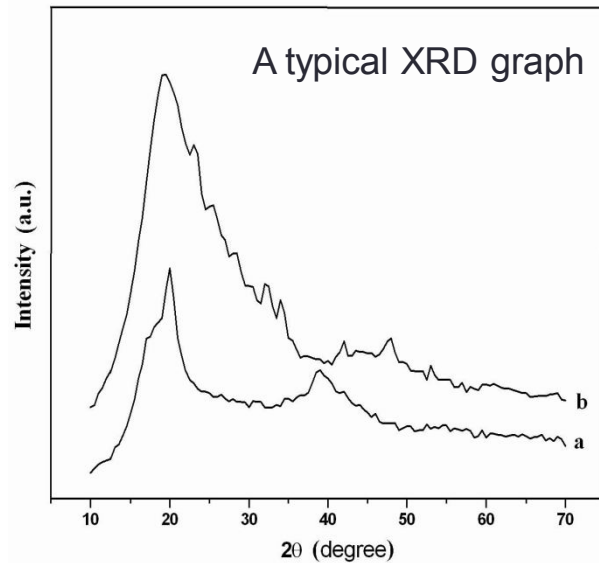

Chellazzi et al., Nature Materials 3, 470 - 475 (2004)

Polymers exhibit structural hierarchy at multiple length scales:

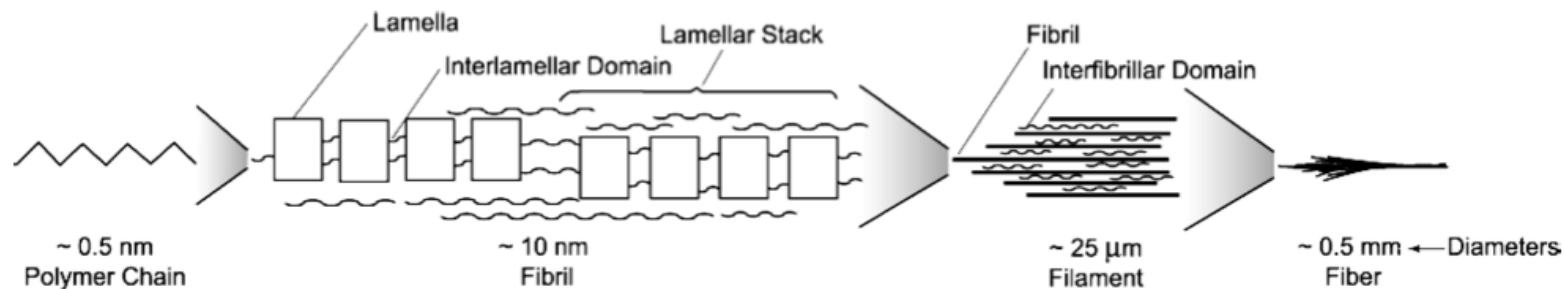

X-ray scattering can be used to obtain structural information at three length scales: 1, 10 and 100 nm using scattering at wide-, small- and ultra small-angles, respectively.

Crystallinity can be determined from a wide-angle X-ray diffraction (WAXD) scan by comparing the area under the crystalline peaks to the total scattered intensity.

3. X-RAY DIFFRACTION ANALYSIS

- Chain Conformations
- Disorder in the Crystal Structure
- Chain Packing
- Orientation

Determination of structural gradients:

The higher orientation of the crystalline parts in the skin layer of polymer

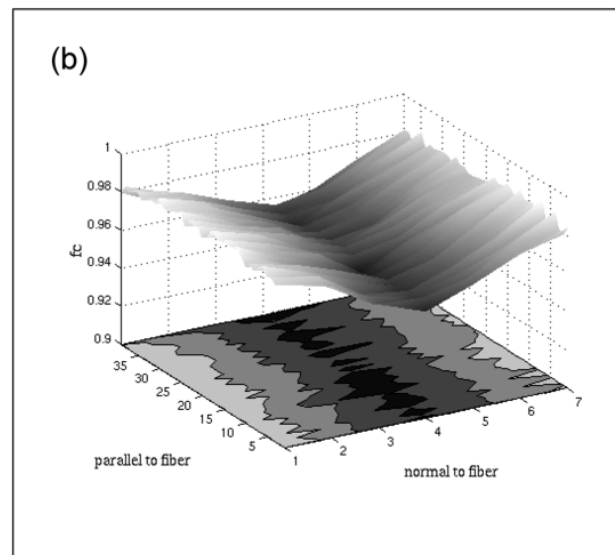
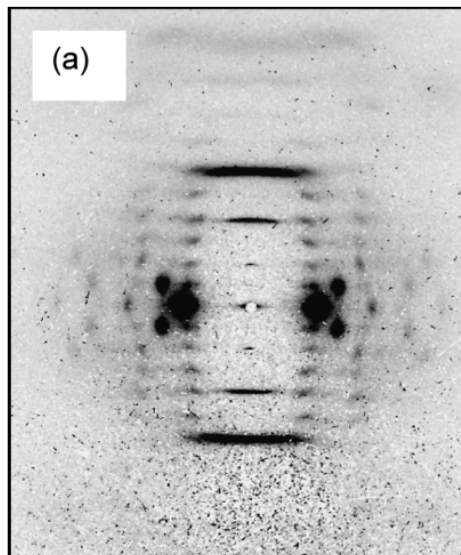

a) Wide-angle X-ray diffraction data from a Kevlar fiber using 3 μm diameter beam
(b) Plot of the Herman's orientation function (f_c).

4. MICROSCOPY

- Light Microscopy
- Transmission Electron Microscopy
- Scanning Electron Microscopy

4. MICROSCOPY

Light Microscopy

Reflected-light microscopy is valuable for examining the texture of solid opaque polymers. Resolution is around 200 nm.

Two common techniques are used:

- 1) Polarized-light microscopy
- 2) Phase-contrast microscopy

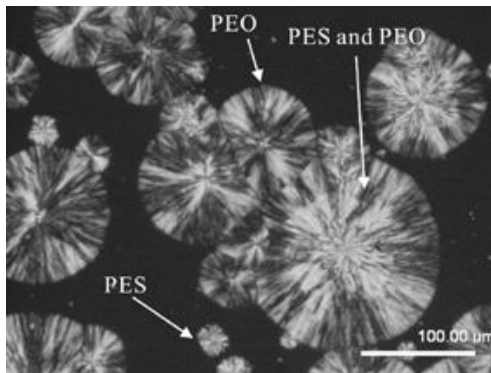

Polarized-light microscopy image of PES and PEO spherulites.

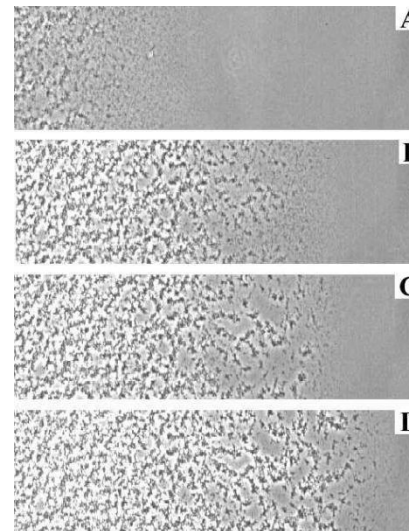

Phase contrast microscopy images of various stages of polymerization of a 2 wt% BAB in toluene after A) 8, B) 26, C) 28, and D) 46 s of UV irradiation.

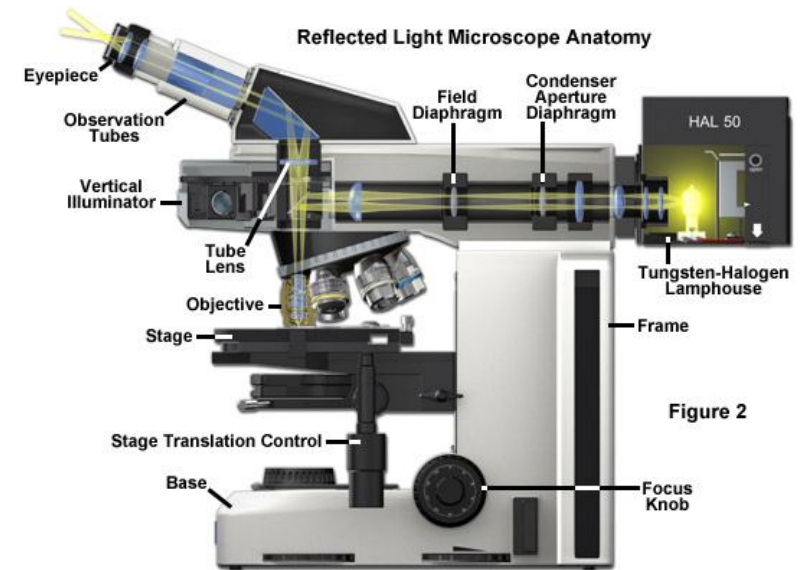
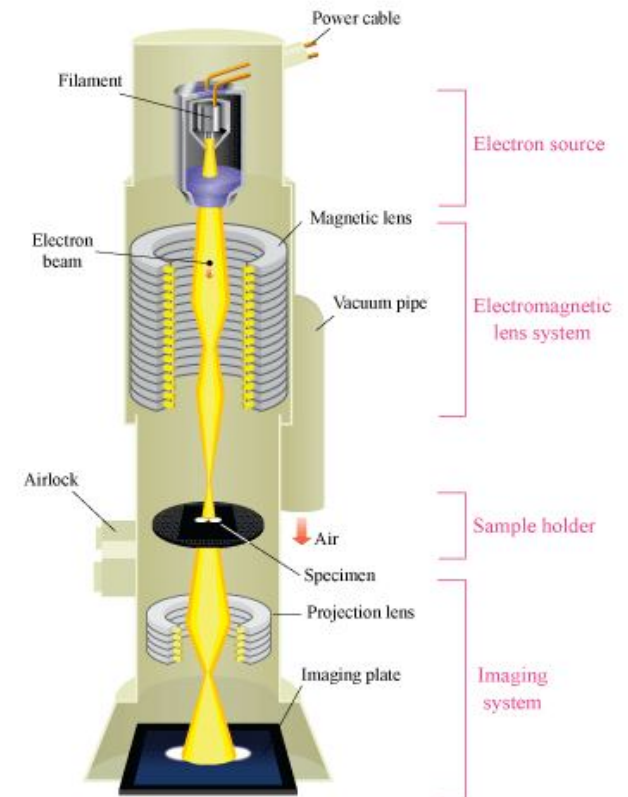

Figure 2

- Interference microscopy, allowing measurement of thicknesses as low as a few angstrom units, has proved valuable in the study of polymer single crystals.

Transmission Electron Microscopy

- TEM has been a powerful tool in the study of the morphology of crystalline polymers since the practical limit of resolution is a few angstrom units.
- In TEM, a beam of electrons pass through the specimen. The electrons that pass through the specimen are detected on a fluorescent screen on which the image is displayed.
- Thin sections of specimen are needed for transmission electron microscopy as the electrons have to pass through the specimen for the image to be produced.
- A severe problem, however, is damage of the specimen by the electron beam. Typically, polymer single crystals are severely damaged in times of a few seconds to a minute.



Transmission Electron Microscopy

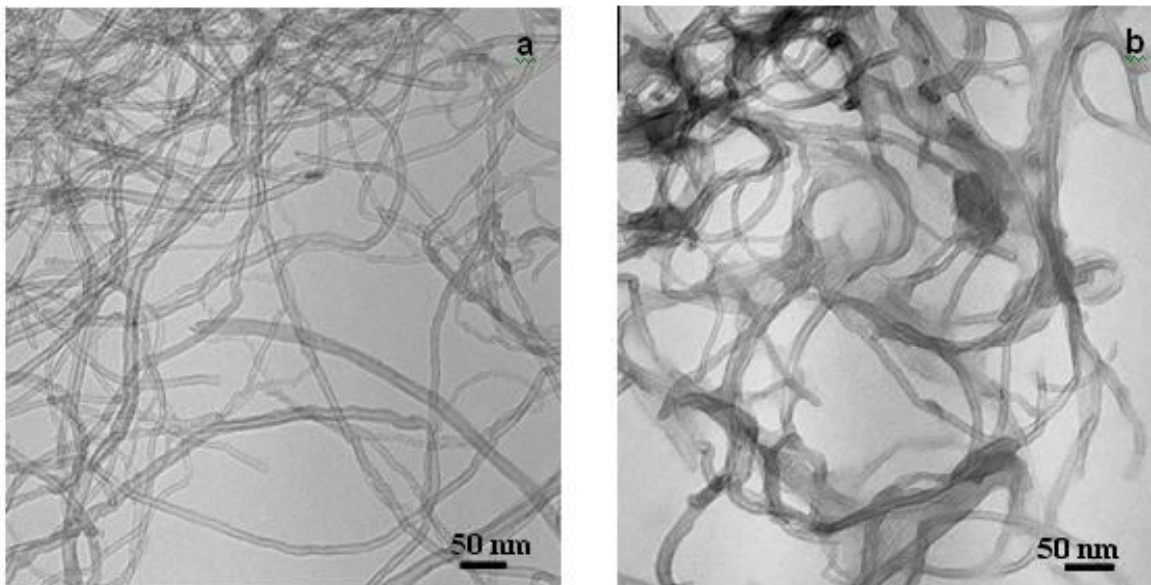

TEM images of
a) carbon nanotubes and
b) SPEEK-coated carbon
nanotubes

M.-R. Babaa et al. J. Nanosci. Nanotechnol. 7, (2007)

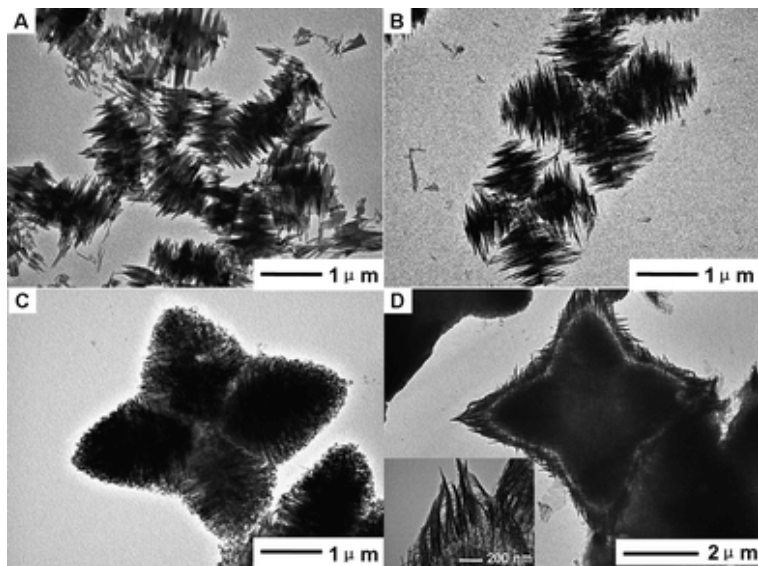

Typical TEM images of polyaniline
doped with aspartic acid at different
concentrations.

Jin et al. J. Mater. Chem., 2010,20, 3079-3083

Scanning Electron Microscopy

- SEM scans a fine beam of electron onto a specimen and collects the electrons scattered by the surface.
- The need for sputter coating step: the opaque specimen is coated with a light conducting film (heavy metals).
- This has poorer resolution than TEM (around 5 nm), but gives excellent 3-dimensional images of surfaces.

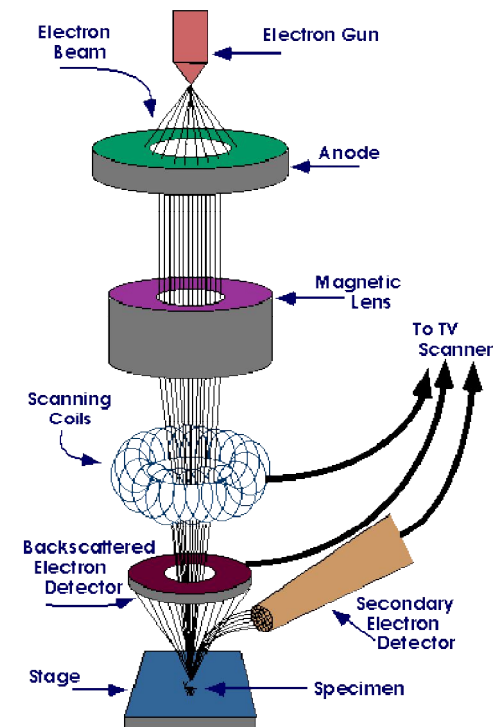

Scanning Electron Microscopy

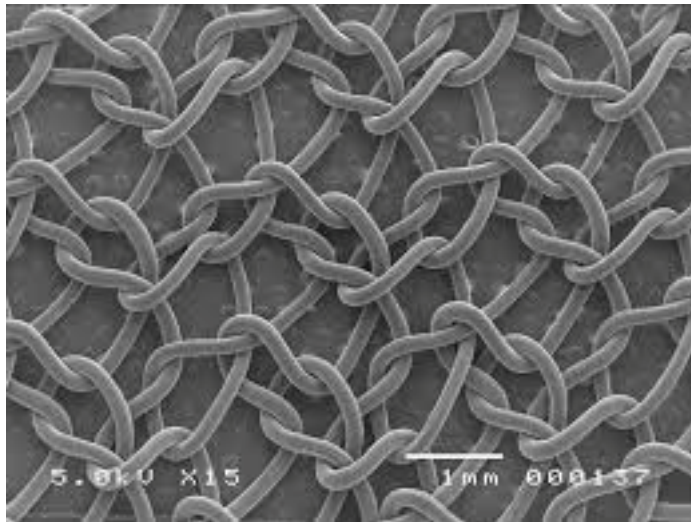

TephaFLEX Surgical Mesh

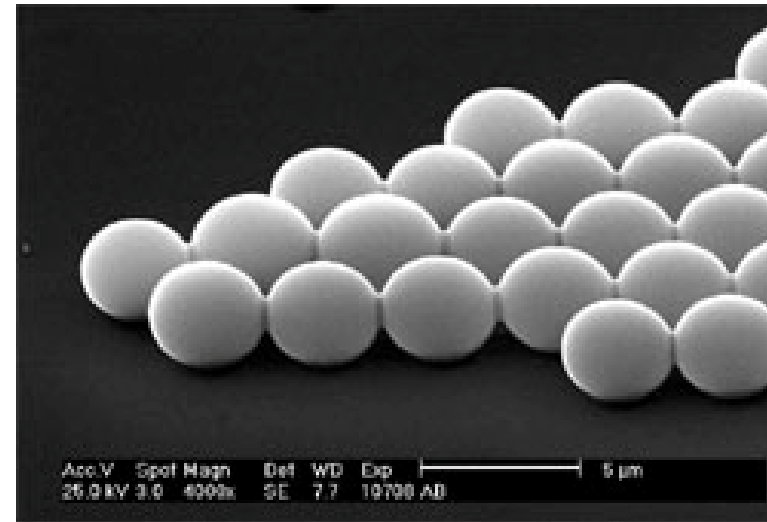

Polystyrene beads

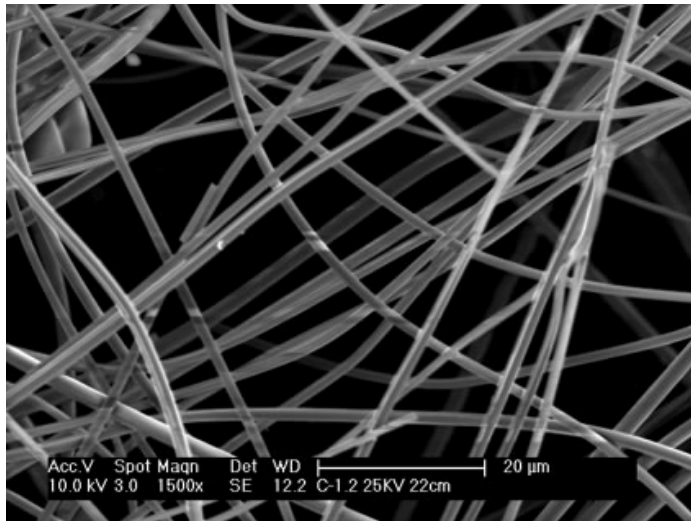

PCS fiber

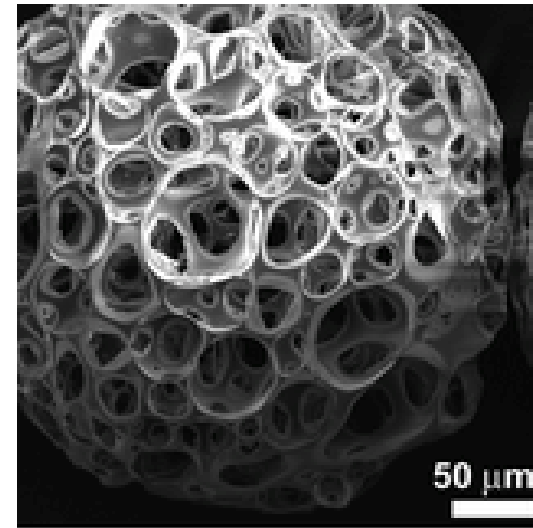

PLGA porous beads

5. THERMAL ANALYSIS

The field of the thermal analysis of polymers has expanded greatly since the introduction of simple, inexpensive instruments (compared to classical instrumentation) for several types of thermal measurements just over 20 years ago.

In addition to the traditional calorimetric and differential thermal analysis, the field now includes equipment for thermo-gravimetric analysis, thermo-mechanical analysis, electrical thermal analysis, and effluent gas analysis.

Not only can one study the enthalpy changes associated with heating, annealing, crystallizing, or otherwise thermally treating polymers, but one can now study a wide variety of responses of the system to temperature, including polymerization, degradation, or other chemical changes.

5. THERMAL ANALYSIS

Differential Scanning Calorimetry

- Differential Scanning Calorimetry, or DSC, is a thermal analysis technique that looks at how a material's heat capacity (C_p) is changed by temperature (controlled temperature program).
- A sample of known mass is heated or cooled and the changes in its heat capacity are tracked as changes in the heat flow.
- This allows the detection of transitions like melts, glass transitions, phase changes, and curing.



Polymers	T_g	Indicator of material properties, QC, effect of additives
	T_m	Polymer processing, heat history
	Exotherm	Reactions rate, curing of materials, residual cure
	C_p	Energy needed to process
	T_c	Recrystallization times, kinetics

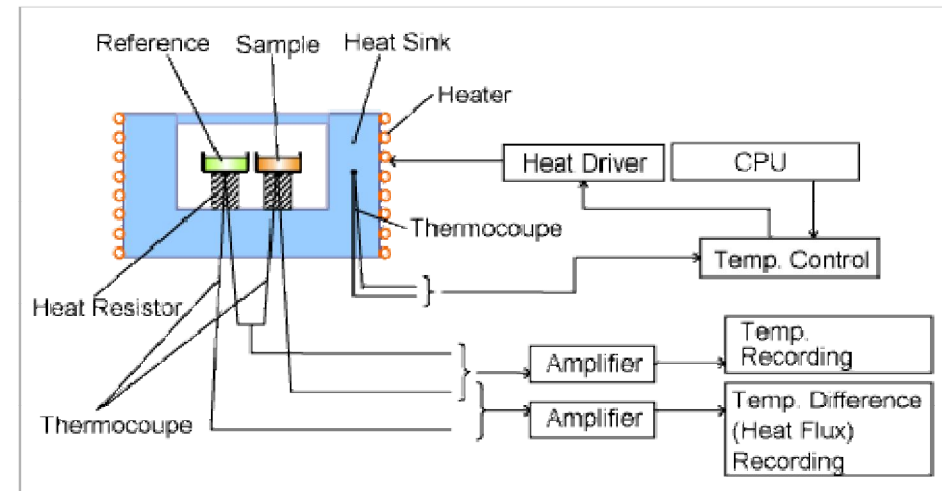

- Although the DSC is less accurate than a good adiabatic calorimeter (which is expensive) (1-2% versus 0.1 %), its accuracy is adequate.

Differential Scanning Calorimetry

DSC enables easy and quick measurement of important characteristics of a polymer:

- Enthalpy of Melting
- Extent of cross-linking
- Glass Transition Temperature (T_g)
- Initial Crystallinity
- Melting Temperatures (Onset, Endset)
- Thermal Stability

Possible Transitions in a DSC Curve

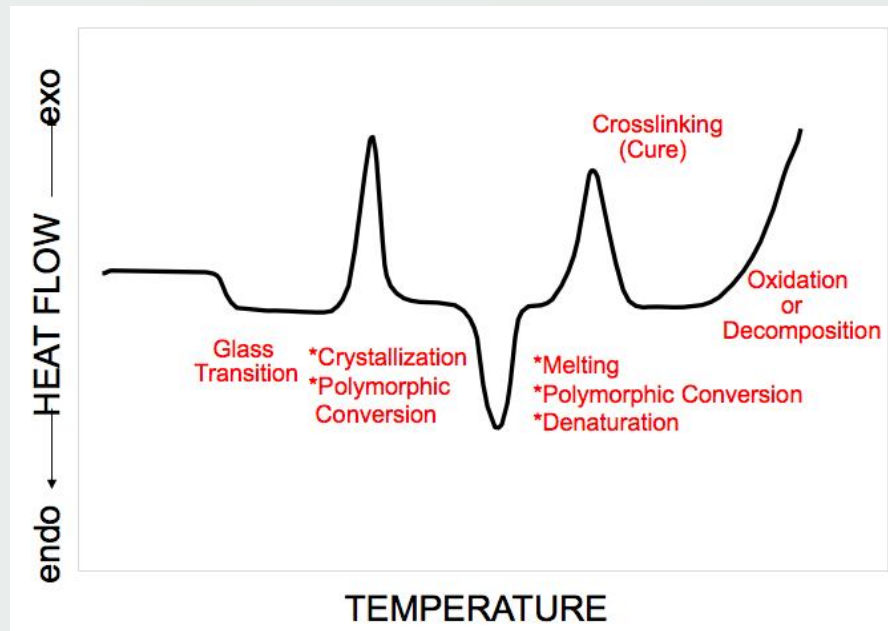

Melting process

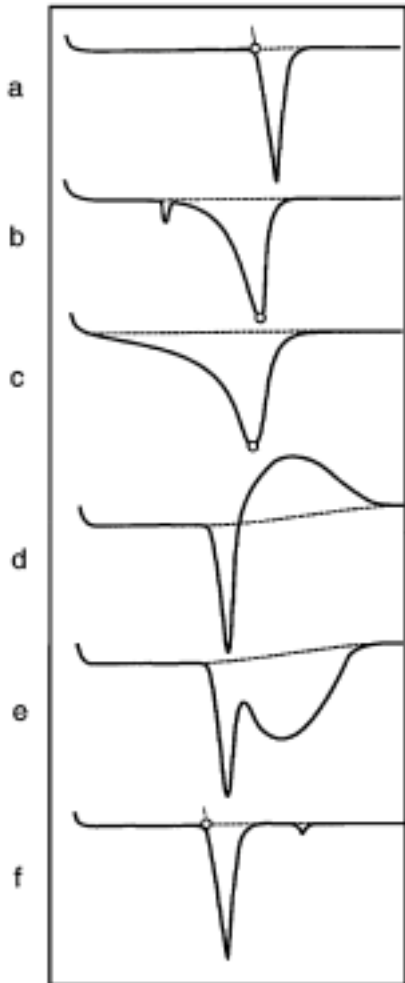

- a) Nonpolymeric pure substance
- b) A sample with eutectic impurity
- c) A partially crystalline polymer
- d) Melting with decomposition
- e) Melting with decomposition
- f) A liquid crystal

Crystallization process

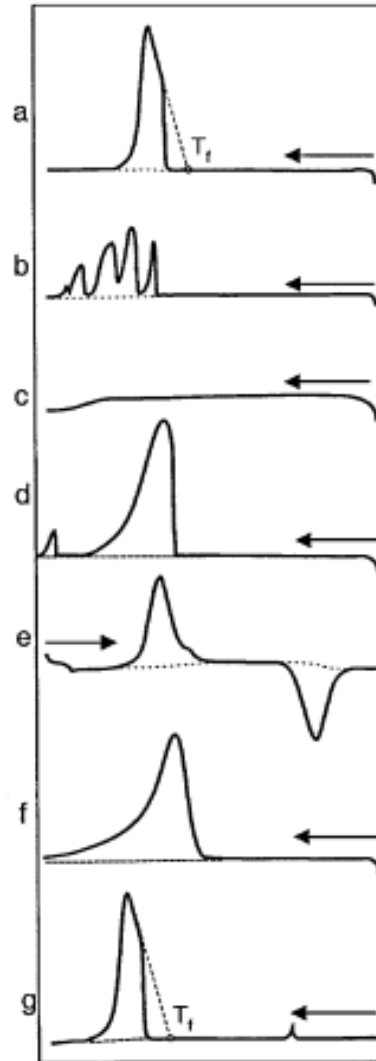

- a) A pure substance
- b) Separate droplets solidify with individual degrees of super cooling
- c) A melt that solidifies amorphously
- d) A sample with eutectic impurity
- e) Cold crystallization
- f) A partially crystalline polymer
- g) A liquid crystal

Step transitions

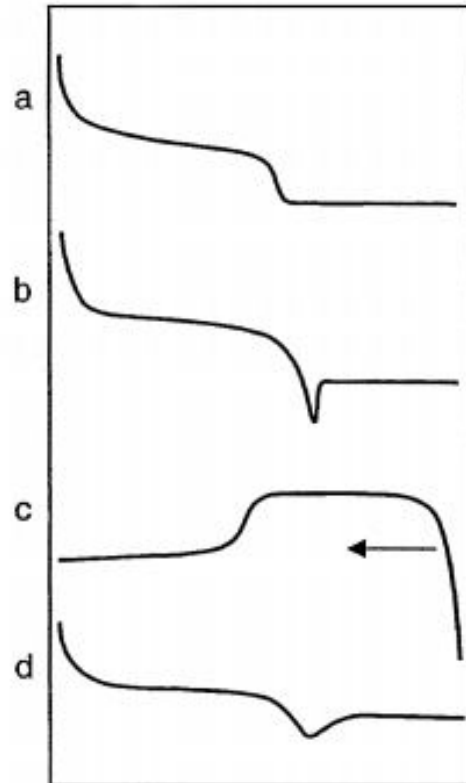

- a) A glass transition
- b) Glass transition with enthalpy relaxation
- c) The reverse transition
- d) A Curie transition

The effect of some parameters on glass transition

Summary		
Crystallinity	Effect on the glass transition: Increasing crystallinity → smaller step height; The glass transition is larger and broader.	Special comments: For low molecular substances, the crystallinity can be determined from Δc_p ; for polymers the proportion of the T_g rigid amorphous phase
Crosslinking, curing, polymerization, molar mass	T_g shifts to higher temperature with increasing molar mass or crosslinking.	T_g bei M_n ab ca. 10^4 g/mol is constant
Orientation and storage below T_g	Internal stresses and storage shift T_g and increase the size of the enthalpy relaxation peak.	Possible crystallization in the glass transition region; Often, the first measurement cannot be used; Possibly use the evaluation, according to Richardson. The relaxation peaks contain information about the sample history.
Plasticizers	Plasticizers shift T_g to lower temperatures.	Solvent residues and moisture often behave as plasticizers (T_g is higher in the 2nd measurement if weight loss occurs)
Mixtures	Incompatible mixtures give two transitions, compatible mixtures only one.	The content can be determined from T_g as a function of the composition or the step height;
Copolymers	Block and graft copolymers of compatible monomers and statistical copolymers show one transition; otherwise two transitions.	T_g and the width of the transitions depend on the interactions of the phases.
Chemical modification	T_g step height and the width of the transition can change; several transitions can occur.	By specific chemical modification or chemical aging such as oxidation or degradation of polymers
Fillers	The step height decreases with increasing filler content.	Hardly any effect on T_g

5. THERMAL ANALYSIS

Thermogravimetric Analysis

In thermogravimetric analysis (TGA) a sensitive balance is used to follow the weight change of the sample as a function of temperature.

Typical applications include the assessment of:

- Thermal stability
- Decomposition temperature
- The extent of cure in condensation polymers
- Composition and some information on sequence distribution in copolymers
- Composition of filled polymers

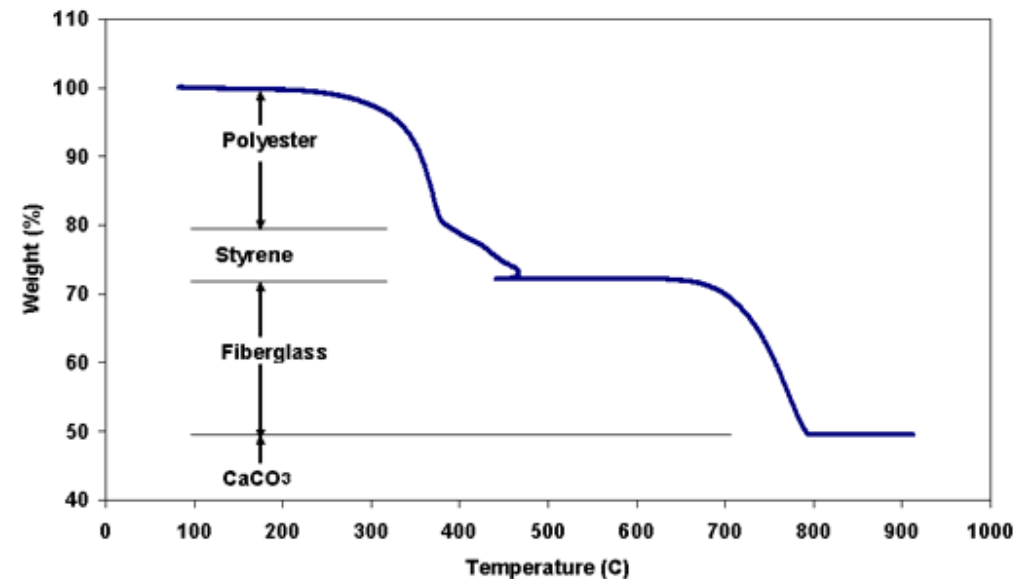
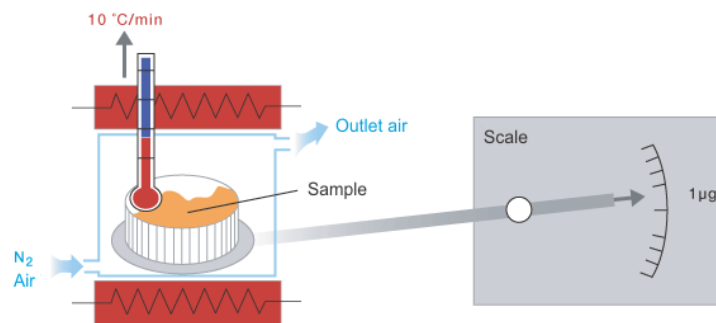

Thermogravimetric Analysis

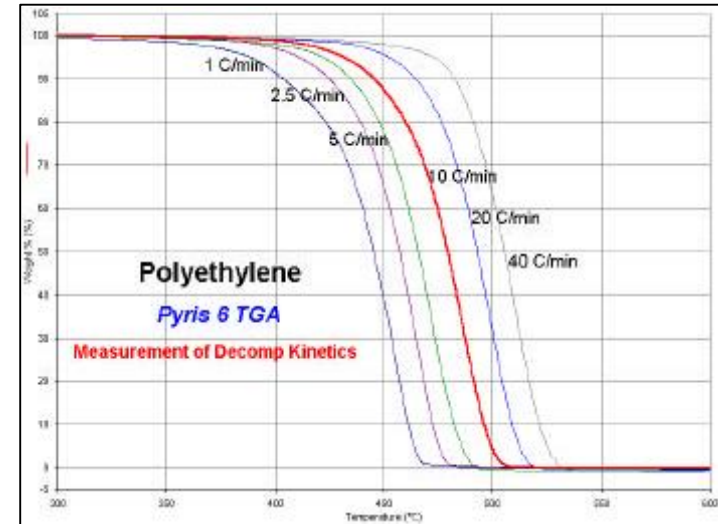
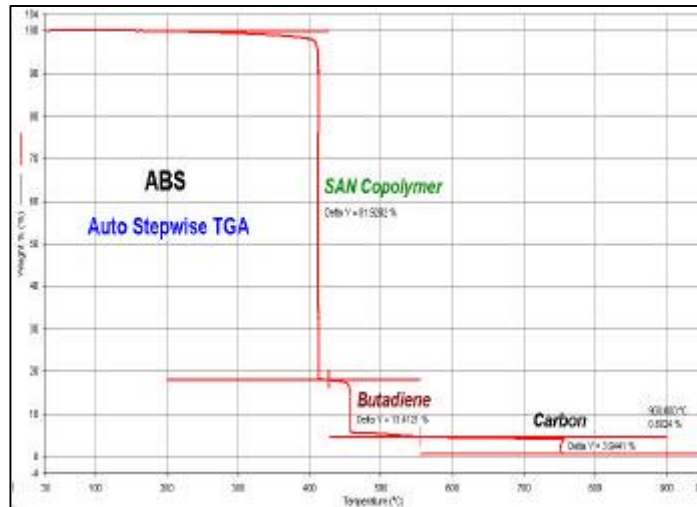
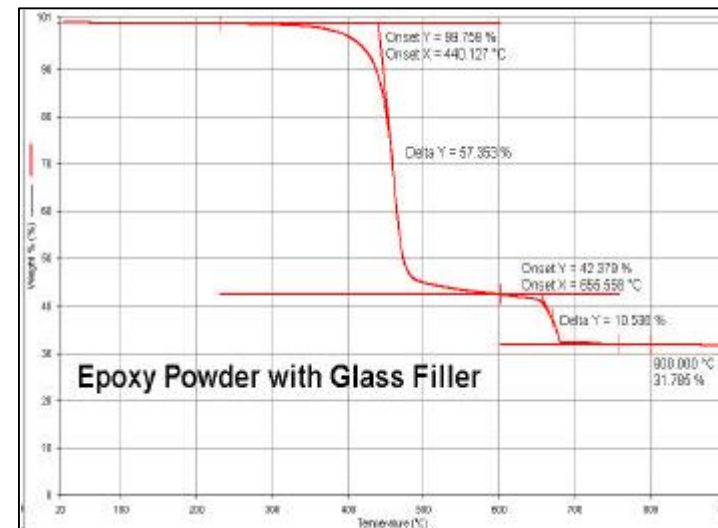
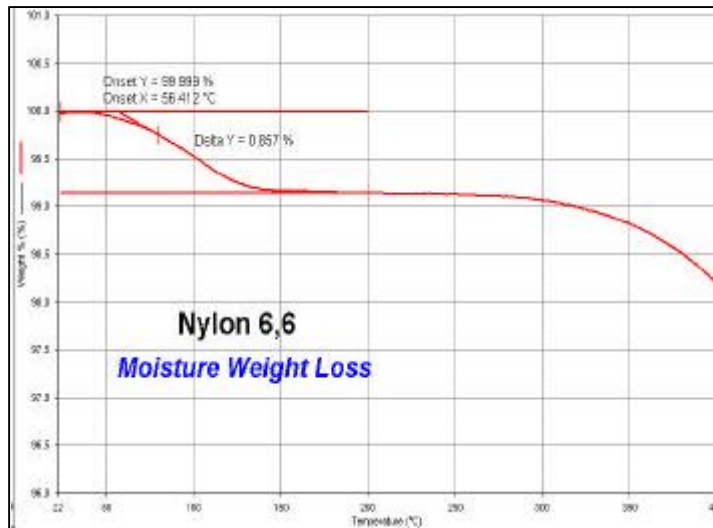

Differential Thermal Analysis

In differential thermal analysis (DTA) the sample and an inert reference substance (undergoing no thermal transition in the temperature range of interest) are heated at the same rate (controlled heating program)

The temperature difference between sample and reference is measured and plotted as a function of sample temperature.

DTA curve provides data on the transformations that have occurred, such as glass transitions, crystallization, melting and sublimation.

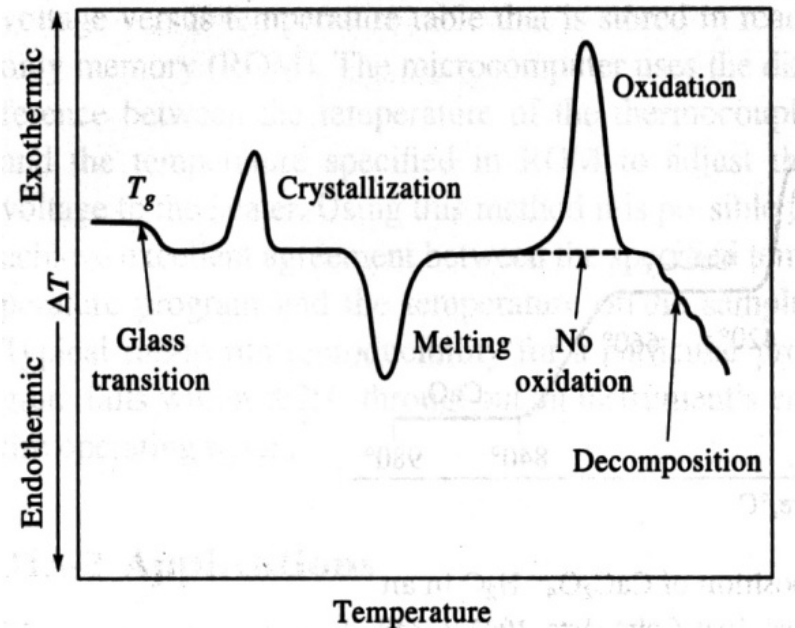

Differential Thermal Analysis

Determination of latent heat of fusion

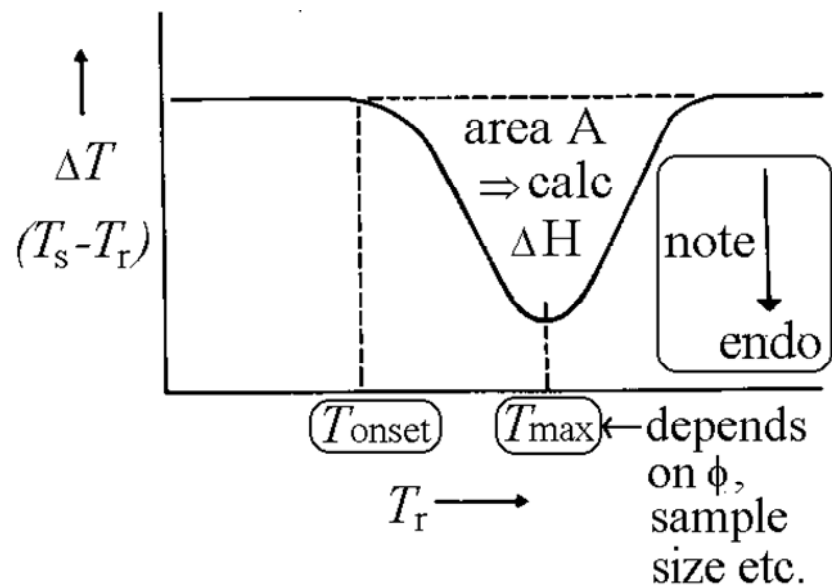

Analysis of polymer mixtures

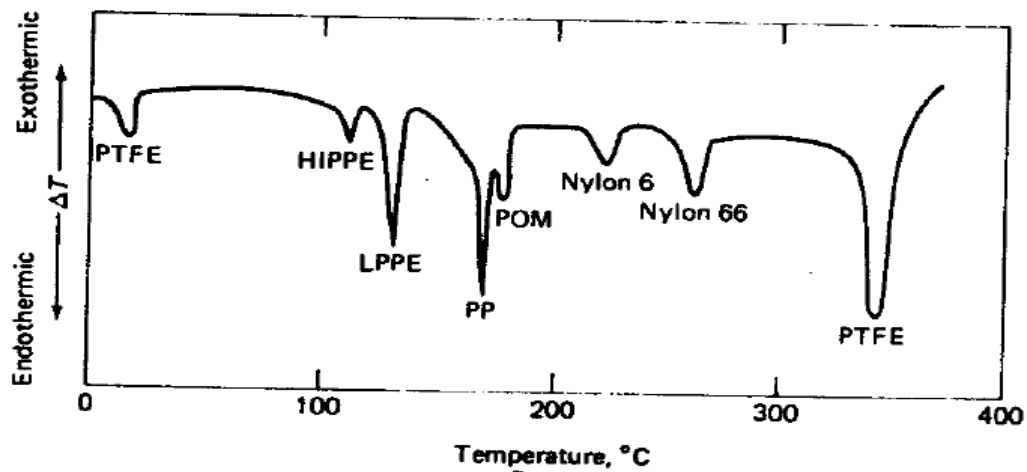

Characterization of polymers

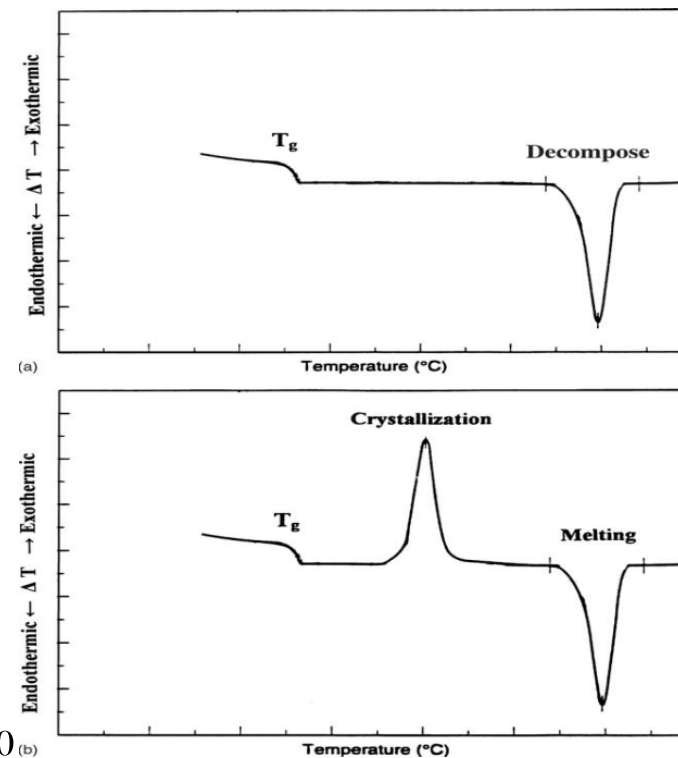

6. PHYSICAL TESTING

- Mechanical Properties
- Thermal Properties
- Optical Properties
- Electrical Properties
- Chemical Properties

Mechanical Properties

Stress-Strain Properties in Tension:

One of the most informative mechanical experiments for any material is the determination of its *stress-strain curve in tension*. This is usually done by measuring continuously the force developed as the sample is elongated at constant rate of extension.

The generalized stress-strain curve for plastics

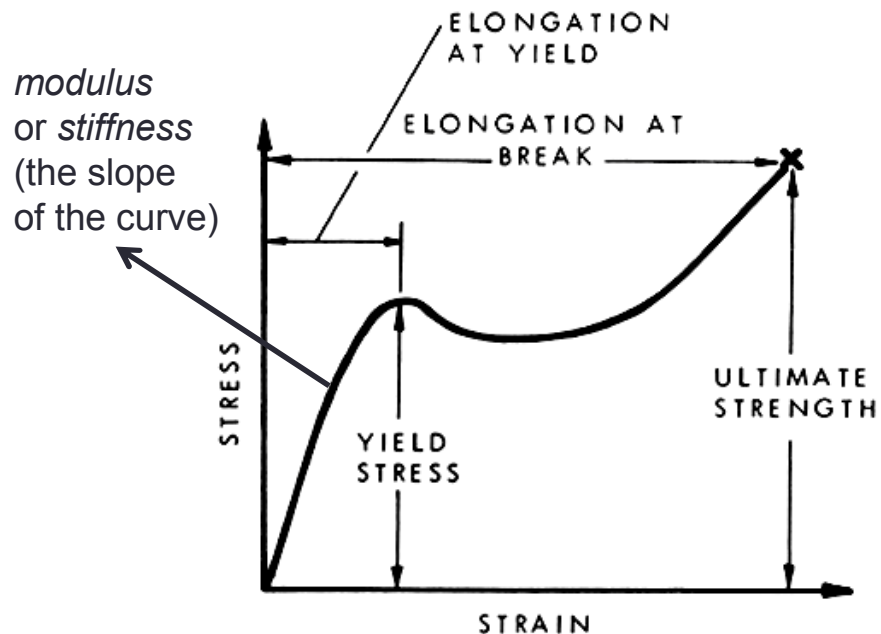

Elongation experiment of a polymeric membrane

Tensile stress-strain curves for several types of polymeric materials

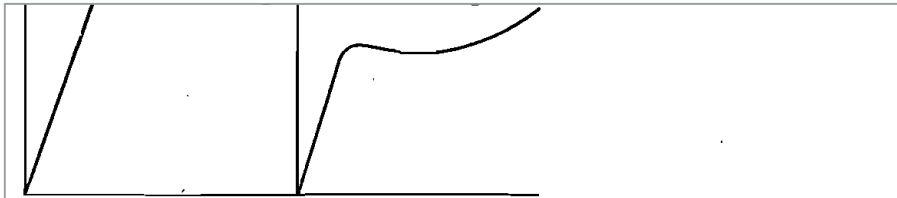
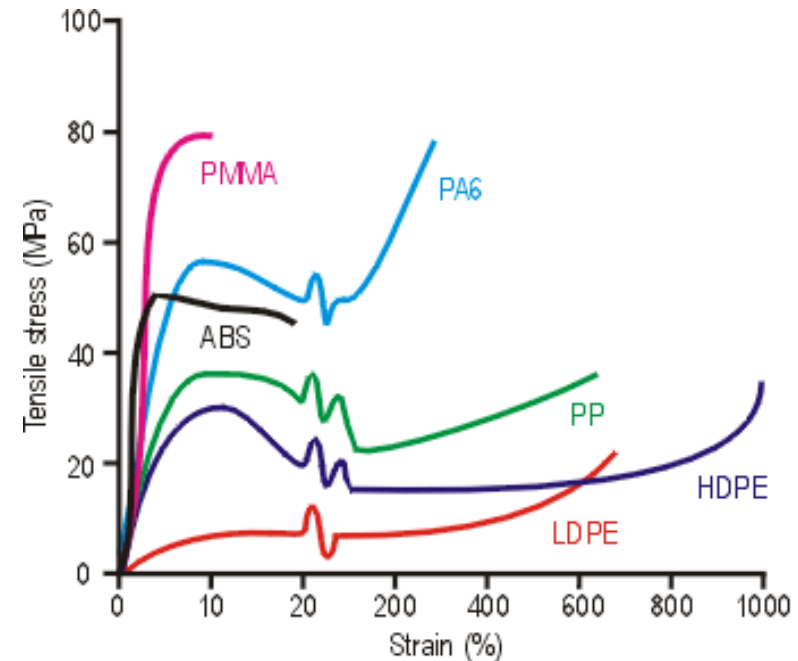

FIG. 9-8. Tensile stress-strain curves for several types of polymeric materials (Winding 1961).

ed. These may include (for stiffer materials) measurement of *flexural modulus* (for less stiff materials) *flexural or folding endurance tests* (see next paragraph)

fatigue Tests. When subjected to cyclic mechanical stresses, most materials fail at a stress considerably lower than that required to cause rupture in a single stress cycle. This phenomenon is called *fatigue*. Various modes of fatigue testing in common use include alternating tensile and compressive stress and cyclic flexure stress. Results are reported as plots of stress versus number of cycles to fail. Many materials show a fatigue endurance limit, or a maximum stress below which fatigue



PHYSICAL TESTING

247

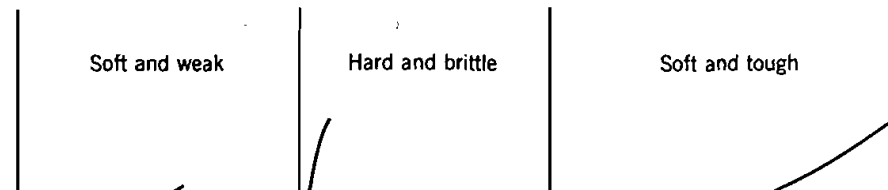

In addition to tensile measurements, tests may also be performed in **shear, flexure, compression or torsion.**

Fatigue Tests:

When subjected to cyclic mechanical stresses, most materials fail at a stress considerably lower than that required to cause rupture in a single stress cycle.

This phenomenon is called fatigue which may arise from the absorption of energy in a material that is not perfectly elastic.

Various modes of fatigue testing in common use include alternating tensile and compressive stress and cyclic flexural stress.

Important aspects:

- Fatigue endurance limit
- Maximum stress below which fatigue failure never takes place

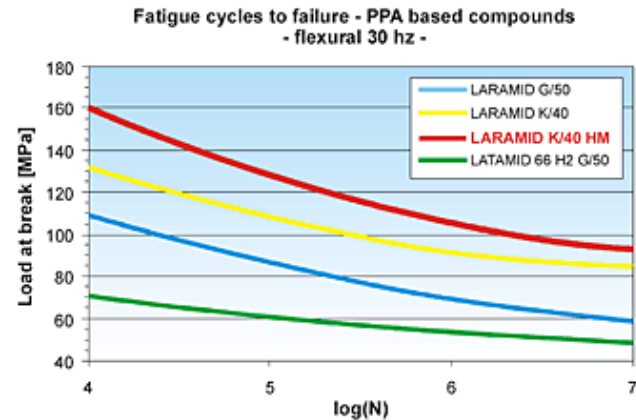

Tear resistance:

When plastics are used as films, particularly in packaging applications, their resistance to tearing is an important property.

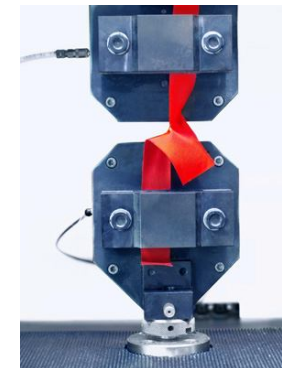

Impact Tests:

Brittle failure is characterized by lack of distortion of the broken parts



In ductile rupture the specimen is permanently distorted near the point of failure.



Important aspects:

- The brittle point, or temperature at the onset of brittleness (the temperature at which half the specimens fail by brittle rupture)
- Impact strength (a pendulum with a massive striking edge is allowed to hit the specimen)

Hardness:

Hardness is a composite property combining concepts of resistance to *penetration, scratching, marring* and so on.

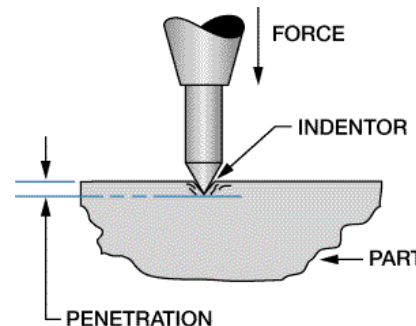

Abrasion Resistance:

Abrasion resistance in plastics usually takes the form of a scratch test, in which the material is subjected to many scratches, usually from contact with an abrasive wheel or a stream of falling abrasive material.

The degree of abrasion can be determined by loss of weight for severe damage, usually measured by evidence of surface marring, such as loss of gloss or development of haze in transparent specimens.

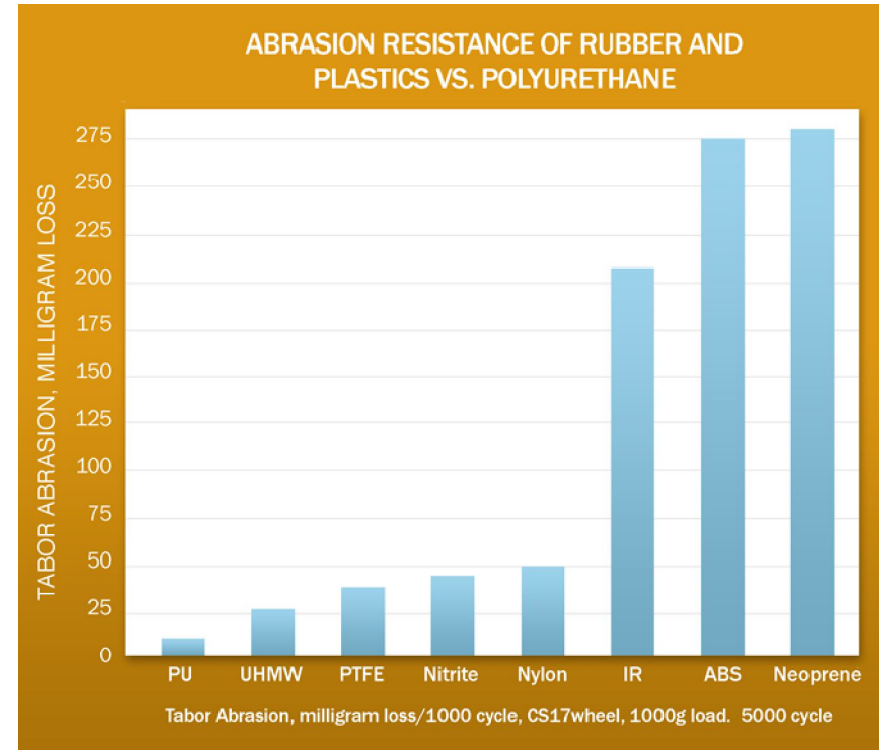

Thermal Properties

Softening Temperature:

a) Vicat test:



b) Deflection temperature or heat distortion test:

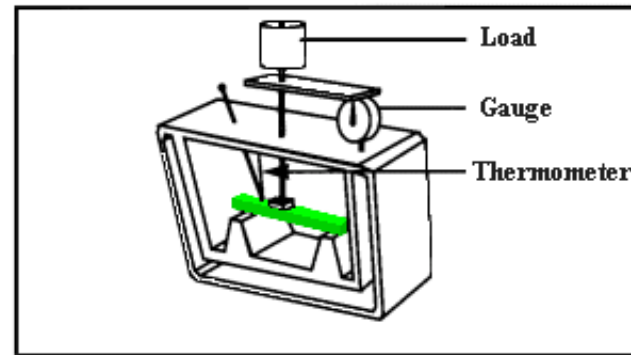

c) Zero-strength temperature test:



d) Polymer melt or stick temperature test



Flammability:

The flammability of plastics is usually tested as the burning rate of a specified sample. The self-extinguishing tendency is also important.



6. PHYSICAL TESTING

Optical Properties:

Transmittance and reflectance, color, gloss, haze, transparency

Electrical Properties:

Dielectric constant and resistivity are important properties of polymers as insulating materials. Dielectric strength, arc resistance, electronic properties are also very important.

Chemical Properties:

Resistance to solvents (*solubility, swelling, environmental stress cracking, crazing*), vapor permeability (solubility and diffusion coefficient of the gas or vapor), weathering

7. PROJECT DESCRIPTION

IDENTIFICATION OF AN UNKNOWN POLYMER SAMPLE

In this project, students are going to determine the chemical structure of an unknown polymer sample by making necessary analyses. There will be 5 groups in the class and each group will be responsible for the identification of a different sample.

Methods:

- Fourier Transform Infrared Spectrophotometer (FTIR)
- Differential Scanning Calorimeter (DSC)
- Thermal Gravimetry Analyzer (TGA)

Groups should schedule analysis dates for FTIR Spectroscopy, TGA and DSC analyses with Ms. Belgin Arslan from General Analysis Laboratory.

8. OUR DEPARTMENT'S ANALYSIS LABORATORY EQUIPMENTS FOR POLYMER TESTING

- Fourier Transform Infrared Spectrophotometer (FTIR)
- Differential Scanning Calorimeter (DSC)
- Thermal Gravimetry Analyzer (TGA) and Differential Thermal Analyzer (DTA)



Fourier Transform Infrared Spectrophotometer (FTIR)

- **Nicolet™ iS™ 10 FT-IR Spectrometer (Thermo-Scientific, ABD)**
- Wavenumber range: 400 – 7500 cm^{-1}
- KBr method: For a 13 mm diameter pellet, approximately 0.1 to 1.0 % sample is well mixed into 200 to 250 mg KBr and finely pulverized. A force of 8 tons is to form transparent pellets.
- ATR method is able to measure powder samples directly.



Transmission



Attenuated Total Reflectance (ATR)

Fourier Transform Infrared Spectrophotometer (FTIR)

FULL SPECIFICATIONS	
Height (Metric)	250 mm
Weight (Metric)	33 kg
Accepts	SMART Accessories, TGA-IR, Continuum Microscope, Photoacoustic, Most Standard Accessories
Applications	Biodiesel Blending Analysis; Gemstone Analysis; KI
Humidity	Tightly sealed to resist ambient humidity.
Width (Metric)	570 mm
Interface	PC USB 2.0
Beam Splitter	KBr/Ge mid-infrared optimized (standard); XT-KBr/G
Laser	HeNe
Performance Verification	ASTM E1421 to meet customer ISO/GLP requirements,
Components	Mid-infrared Ever-Glo and Tungsten/halogen (both are user replaceable from sample compartment)
Power Supply	100-240 V 50/60 Hz
Depth (Metric)	550 mm
Source Type	Mid-infrared Ever-Glo and Tungsten/halogen (both a
Spectral Range	400-7,500 wavenumber or 400-9,000 wavenumber (XTKB
Description	The Nicolet IS10 FT-IR spectrometer is a complete infrared spectroscopy system for routine analytical needs. The Nicolet IS10 delivers the highest confidence in the verification and identification of materials.
Spectral Resolution	Better than 0.4 wavenumber
Detector Type	Fast recovery deuterated triglycine sulfate (DTGS) (standard); Liquid-nitrogen-cooled mercury cadmium telluride (MCT) (optional)
Item Description	Nicolet IS10 FT-IR Spectrometer

Differential Scanning Calorimeter (DSC)

- **Diamond DSC (Perkin-Elmer, ABD)**
- Temperature range: (-170°C) – (+730°C)
- Heating/Cooling scanning rate: 0.01 to 500 °C/min
- Calorimetry dynamic range: 0.2 μ W – 800 mW
- Purge gas: Nitrogen



- A nominal weight of 5 mg is a good amount for DSC analysis
- 20 °C/min heating rate can be selected to detect transitions

Differential Scanning Calorimeter (DSC)

DSC Type	Power-compensation temperature null principle. Measures temperature and energy directly, rather than differential temperature (DT).	
DSC Cell	Independent dual furnaces constructed of platinum-iridium alloy with independent platinum resistance heaters and temperature sensors with furnace mass less than 1g.	
Temperature Sensors	Distributed, Platinum Resistance Thermometers for best linearity.	
Atmosphere	Static or dynamic, including nitrogen, argon, helium, carbon dioxide, air, oxygen or other inert or active gases, over full temperature range. Oxygen can be used up to 730 °C which allows easy cleaning.	
Temperature	Range	-170 °C to 730 °C
	Accuracy / Precision	±0.1 °C / ±0.01 °C
Calorimetry	Accuracy / Precision	< ±1% / < ±0.1%
	Sensitivity	0.2 µW
	Dynamic Range	0.2 µW to 800 mW
Signal Response	(1 mg Indium, 10 °C/min, nitrogen purge)	
	Peak Height	7.44 mW ± 0.15 mW
	Width at half height	0.42 ± 0.10 °C
	H/W Ratio	17.6 mW/°C ± 1 mW/°C
Isothermal Drift (10 min)	-150 °C / 100 °C	< 15 µW / < 10 µW
Scanning Rates	Heating/Cooling	0.01 °C to 500 °C/min
Temperature Overshoot	100 °C/min	< 0.1 °C
Controlled Cooling	Ambient Coolant - nitrogen purge 10 °C/min to 50 °C 20 °C/min to 65 °C 50 °C/min to 100 °C 100 °C/min to 170 °C Liquid N ₂ Coolant - helium purge 10 °C/min to -170 °C 50 °C/min to -165 °C 100 °C/min to -135 °C 200 °C/min to -85 °C 300 °C/min to -80 °C 400 °C/min to -10 °C	
Cooling Times	Ambient Coolant	725 °C to 100 °C (under 4 minutes)
	Liquid N ₂ Coolant	200 °C to -150 °C (under 2 minutes)
Cooling Options	Ice Water	25 °C to 730 °C
	Circulating Liquid	-10 °C to 730 °C
	Refrigerator (Intracooler)	-70 °C to 730 °C
	Automatic Liquid N ₂ (CryoFill)	-170 °C to 300 °C
Autosampler	The Diamond DSC Autosampler can run up to 44 sample positions unattended. It has the ability to be customized through Pyris Player to meet your analysis needs and increase productivity.	
High Pressure Cell	Extends the capabilities of the power-compensation Diamond DSC design to elevated pressure measurements. Pressure range is up to 42 bar (600 psi).	
Quality Assurance	Developed under ISO 9001	
Dimensions (HxWxD)	34 x 40 x 67 cm (14 x 16 x 27 in)	
Weight	20 kg (44 lbs)	
Power Requirements	100-240 Volt, 50/60 Hz	

8. ANALYSIS LABORATORY EQUIPMENTS

Thermal Gravimetry Analyzer (TGA) and Differential Thermal Analyzer (DTA)

- **TG/DTA 6300 SII EXSTAR 6000 (Seiko Instruments Inc., ABD)**

- Temperature Range: Laboratory Temperature – 1100 °C
- Temperature Gradient: 0.01–200.00 °C/min
- Temperature Program: up to six steps (heating, constant temperature, cooling)
- TG Measurement Range (Resolution): ± 200.0 mg (0.2 μ g)
- DTA Measurement Range (Resolution): ± 1000.0 μ V (0.06 μ V)
- Atmosphere:
 - oxidative (compressed air)
 - inert (nitrogen)
- Gas Flow: max. 1000 mL/min
- Platinum (0.04 or 0.095 mL) or ceramic (0.04 mL) crucibles

