

# KM26

Magnetic Level Gauge, MagWave Dual Chamber Level System & External Chamber



For the latest version of this manual, visit [ktekcorp.com](http://ktekcorp.com).

## TABLE OF CONTENTS

1. INTRODUCTION .....	3
1.1 General Description .....	3
1.2 Detailed Description .....	3
1.3 Temperature Considerations .....	4
2. STORAGE & HANDLING INFORMATION .....	4
3. INSTALLATION .....	4
3.1 Float Information .....	4
3.2 Leveling .....	5
3.3 Limit Switches .....	5
3.3.1 Limit Switch Use .....	7
3.3.2 General Installation Guidelines .....	8
3.4 Magnetostrictive Transmitter Installation .....	9
3.5 Isolation Valves .....	10
3.6 Pressure Testing .....	11
3.7 Insulation .....	11
3.8 Scale Zero .....	11
3.9 Replacing Indicator Tube .....	11
3.10 Insulation Instructions .....	11
3.10.1 Insulation Pads .....	12
3.10.2 Tied-On Blanket .....	13
3.10.3 Pipe Wrap Blanket .....	14
3.10.4 Cryogenic Insulation .....	14
4. TROUBLESHOOTING .....	15
4.1 Indicator Decoupling .....	15
4.2 Float Sinks or Sticks .....	15
4.3 Switch Does Not Work .....	15
5. PARTS ORDERING .....	16
6. CUSTOMER SPECIFIC PRODUCT INFORMATION .....	16
7. APPENDIX A .....	17
7.1 KM26S Parts Breakdown Drawing .....	17
7.2 KM26T Parts Breakdown Drawing .....	18
8. APPENDIX B .....	19
8.1 Unpacking .....	19
8.2 Pre-Installation Checklist .....	19
8.3 Equipment & Tools .....	19
8.4 Placing an MLG in Service (Startup) .....	19
8.5 Removing an MLG from Service .....	20
8.6 Maintenance .....	20
8.7 MLG Replacement / Spare Parts .....	20
8.8 Replacement Glass Installation Procedure (Retrofit or Replacement) .....	21
8.8.1 KM26 Shuttle Replacement Glass Installation Procedure (refer to Figures 8-1 and 8-2) .....	21
8.8.2 KM26 Magnetic Bargraph Glass Installation Procedure (refer to Figures 8-3 and 8-4) .....	21
8.9 KM26 Shuttle Replacement Glass Installation Procedure .....	22
8.10 KM26 Bargraph Replacement Glass Installation Procedure .....	24
9. APPENDIX C .....	26
9.1 Warranty Statement .....	26
9.2 RMA Form .....	27

## 1.0 Introduction

### Important Note!

The MagWave (MW) Dual Chamber Level System is comprised of a magnetic level gauge and an independent chamber. The independent chamber typically houses a Guided Wave Radar (MT5000-0200-1) or a Magnetostrictive Level Transmitter (AT200-0200-1). This manual should be used in conjunction with the transmitter manuals for proper installation guidance.

### 1.1 General Description

Features:

- Rugged construction
- Safe for flammable, corrosive, and toxic liquids
- Suitable for pressures from full vacuum to maximum specified pressure
- Special types for high and low temperature operations
- Positive zero indication
- Available with integral limit switches & transmitters

The K-TEK Model KM26S and KM26T Liquid Level Indication system is designed for use in applications where a simple gauge glass cannot be used. Due to its design, the KM26S and KM26T can safely be used with flammable, corrosive or toxic liquids; or where operating conditions exceed safety limits of glass. The rugged construction of the KM26S and KM26T make them ideally suited for use in operating environments where extreme temperature and/or pressure may be encountered.

The basic KM26S and KM26T systems consist of a float, float chamber and an indicator assembly. The float chamber is connected directly to the process vessel. The float chamber contains a magnet assembly and is designed and weighted to float in the process liquid submerged approximately 70 to 80%. The indicator assembly consists of a hermetically sealed glass or polycarbonate tube containing the shuttle or magnetic bar graph indicator and a graduated scale corresponding to the desired operating range. The indicator assembly is mounted in close proximity to the float chamber. Magnetic coupling exists between the float and the indicator. As the float follows changing liquid level, the indicator changes position to reflect that level due to the coupling action.

### 1.2 Detailed Description

The float chamber of the standard KM26 is mounted as a communicating chamber to the process vessel. It is usually vertically flange mounted, but different mounting options are available upon request. Within the float chamber is a float that is designed and manufactured to float with approximately 70 to 80% of its mass submerged in the process fluid. The float magnet assembly is located such that the magnetic actuation point of the magnet assembly is at the liquid level when the fluid is at the specific gravity specified. The position of the float will vary directly with the level of the process fluid.

The indicator assembly, consisting of a glass or polycarbonate tube, an indicator (shuttle or magnetic bar graph), and a graduated scale, is installed parallel and in close proximity to the float chamber. This is necessary to allow for maximum magnetic coupling between the float and the indicator. The indicator and tube are mounted in a stainless steel channel which has a graduated scale attached. The graduations on this scale correspond to the desired operating range. The glass indicator tube is hermetically sealed to prevent the ingress and accumulation of dust and moisture. The indicators are painted with high visibility paint so readings can be obtained from long distances.

Around the middle of the shuttle is a black reference line that directly corresponds to a value on the graduated scale to obtain the process liquid level. The shuttle tube must be in the proper orientation for it to operate correctly and this is determined by the rubber bumper in the glass tube. This bumper, when the tube is correctly oriented, will be below the shuttle at the bottom of the tube. The optional magnetic bar graph indicator is available in yellow/black or red/white for use in locations where temperature is not excessive. The flippers on the bar graph rotate to change color at the fluid level. Consult the factory for applicable temperature limits.

The indicator tube is positioned such that the normal downward travel of the float is stopped at a position that corresponds to the scale zero by a spring mounted on the bottom flange for the KM26S and a float stop tube for the KM26T. Therefore, as long as the float and the shuttle are magnetically coupled, the shuttle will be visible. Both the KM26S and the KM26T are equipped with a float stop spring at the top of the chamber. These springs absorb the stopping force on the float that occurs when fluid levels change rapidly in the chamber.

### 1.3 Temperature Considerations

The KM26 is capable of operation in extreme environments. Special consideration must be given to the components attached to the KM26 when used at these extremes.

At high temperatures, scales, switches, and transmitters must be protected from the adverse effects of these temperatures on their internal components. High temperature insulation is frequently used to raise the limits at which these devices may operate. This insulation should not be removed without adequate replacement. These devices rely on proximity with the chamber to operate, therefore any replacement insulation should not increase the separation of the device from the float. Any additional insulation installed should not trap unwanted heat in these devices.

At low temperatures, condensation, frosting, and freezing are a concern. Insulation for these conditions is provided as an option and in some cases, it is highly recommended. Special indicator tubes are made to reduce the effects of cryogenic chambers on the indicator. These indicator tubes require insulation that can be provided as an option. Recommendations for this insulation are included at the end of this manual. Low temperatures also cause embrittlement of some metals. Chambers and flange bolting must meet the temperature specifications. K-TEK does not recommend customer application of cryogenic insulation.

## 2.0 Storage and Handling Information

To prevent damage to the shipping tubes and/or crates that the level gauges are transported in, these items should not be over-exposed to inclement weather. The KM26 Magnetic Level Gauge should be stored in such a manner that would not allow the indicator tube to be immersed or submerged in any liquid. Sufficient precautions should be taken so that the glass or polycarbonate indicator tubes are not broken or damaged. There are no special storage requirements for the EC chamber themselves, but if there is a transmitter and/or switch, the storage requirements of the transmitter and/or switch must be met. See data sheets for specific requirements.

## 3.0 Installation

### 3.1 Float Information

The KM26S float is shipped inside the chamber unless specified for separate shipment. Most floats are labeled to indicate the top of the float, the specific gravity of the fluid, and the serial number of the chamber for which they are designed. If the float is coated, labeling is not performed and the float should stay with the chamber. The top of the float can be found by locating the magnet placement and direction with respect to the indicator in the scale. The indicator should be attracted to the float, not repelled, when inserted correctly.

The KM26T float is wrapped separately in bubble wrap. The magnet assembly at the end of the float rod is inserted into the top of the guide chamber unless the float rod is too long, in which case it will be shipped outside of the guide chamber. The stop tube and disk are installed over the rod end and into the chamber. Then, the snap ring is inserted into the internal groove to hold the assembly in place. Finally, the float is threaded onto the rod and locked in place with the nut provided.

Floats and indicators are designed so that the magnetic actuation point of the magnets coincide with the fluid level at the reference specific gravity. If specific gravity decreases, the float will have more of its length below the fluid level and give a visual indication that is lower than actually exists. If the fluid specific gravity has significantly changed after the unit has been placed in service, it may be necessary to replace the float in order to allow for accurate level indication. This can change the length and magnet position of the float. The stop springs must be adjusted accordingly. On the KM26S this is accomplished by either stretching or compressing (or cutting) the bottom and top springs. The scale may also have to be adjusted to coincide with the floats' new zero position. To adjust the zero for the KM26T, the float stop tube can be elongated or reduced. Dimensions are provided when the replacement float is designed in Applications Engineering.



Pressure equalized floats require special provisions when being brought into and out of service. Gradual increases/decreases of pressure in the chamber, in increments not to exceed the pressure limits of the float, must be performed. A one-minute wait period between increments is necessary to ensure that the float does not collapse or burst. Contact the applications engineering department at the factory for assistance.

### 3.2 Leveling

The chamber must be vertically level to insure proper operation of the float and its follower. A unit that is not leveled properly may decouple unexpectedly due to friction with the sides or because the float travels too far away from the indicator.

### 3.3 Limit Switches

To signal specific liquid levels, the KM26 can be equipped with over 10 different types of K-TEK limit switches. Magnetically actuated limit switches are the most commonly used devices. They can be clamped to the measuring chamber and are adjustable over the entire measuring range. They are actuated by a magnet incorporated into the float. The process operating conditions will define what limit switch type may be used (Table 3-1).

Available magnetically actuated switches (Table 3-1):

Reed Type: MS30 & MS30EX

Cam Action Type: MS40, MS40EX, & MS41

Pneumatic Type: PS35 & PS45







K-TEK also provides limit switches such as vibrating forks and thermal dispersion switches that provide a trip point and are activated by sensing actual level and are "independent" of float travel (magnet position).

Alternate limit switch technologies:

Liquid Vibrating Forks: RS80 and RS85

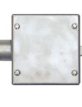
Thermal Dispersion Switches: TX, TQ, and TS

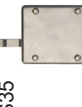
**Table 3-1**

Model #	Agency Approvals	Enclosure		Electrical Connection			Switching Mechanism				Application		
		Type	Rating	Rating	Type	Type	Rating	Min Process Temp	Max Process Temp	Dead-band	Contacts	High Temp	Vibration
MS30 	FM, CSA	Hermetically Sealed	NEMA 4x	1/2" MNPT	Reed	AC/DC 1 amp	-40°F (-40°C) 300°F (149°C); 600°F (316°C)	1/8"	SPDT	•			
MS30/EX 	FM, CSA	Hermetically Sealed, Explosion Proof	NEMA 4x	1/2" FNPT	Reed	AC/DC 1 amp	-40°F (-40°C) 300°F (149°C); 600°F (316°C)	1/8"	SPDT	•			
MS40 	FM, CSA	Stainless Steel	NEMA 4x	1/2" FNPT	Cam Driven, Snap Action	AC: 10 amp DC: 2.6 amp	-60°F (-51°C) 300°F (149°C); 600°F (316°C)	7/8"	DPDT	•	•	•	•
MS40/EX 	FM, CSA	Stainless Steel, Explosion Proof	NEMA 4x	3/4" FNPT	Cam Driven, Snap Action	AC: 10amp DC: 1/2 amp	-60°F (-51°C) 300°F (149°C); 600°F (316°C)	13/16"	DPDT	•	•	•	•
MS41 	FM, CSA, ATEX	Stainless Steel, Dual Compartment, Hermetically Sealed, Explosion Proof	NEMA 4x	1/2" FNPT	Cam Driven, Snap Action	AC: 10amp DC: 2.6 amp	-320°F (-195°C) with option 300°F (149°C); 1000°F (538°C)	15/16"	DPDT	•	•	•	•
PS35 	Non-electric	Stainless Steel	NEMA 4x	1/8" MNPT port	Pneumatic	15 to 100 psig	0°F (-18°C) 180°F (82°C); 450°F (232°C)	1"	Pneumatic Signal				•
PS45 	Non-electric	Stainless Steel	NEMA 4x	1/8" MNPT port	Pneumatic	1 to 100 psig	0°F (-18°C) 180°F (82°C); 450°F (232°C)	15/16"	Pneumatic Signal				•

\*Requires use of insulation pad or insulation jacket / rod mount assembly. Consult specific product data sheet for detailed guidance.

### 3.3 Limit Switches (continued)

All limit switches are delivered as factory assembled to the KM26 in most cases (Figure 3-1). Please consult the applicable limit switch product data sheets for specifications, dimensions, ratings, and approvals.

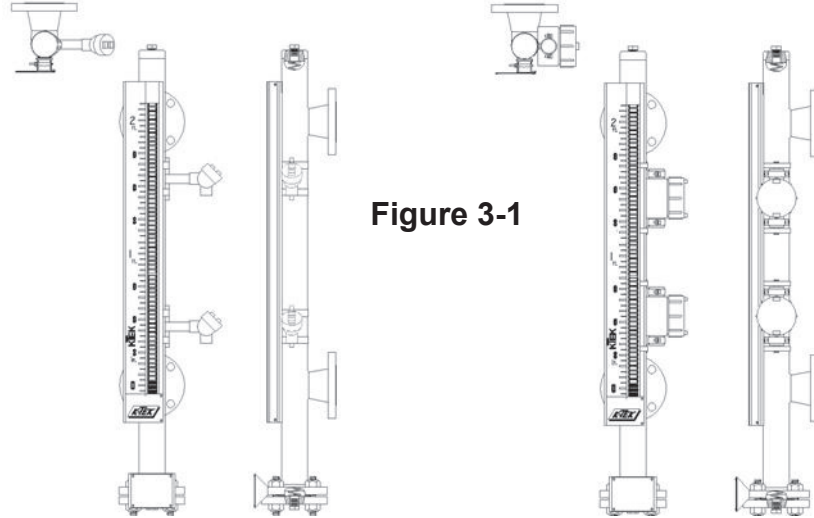

Figure 3-1

#### 3.3.1 Limit Switch Use

A magnetically actuated limit switch is usually mounted using two stainless steel clamps that are fastened through mounting slots (not all models), then attached to the switch housing and strapped around the KM26 chamber. The switch can be easily positioned by loosening the clamp with a 5/16" nut driver and sliding the switch to the correct position on the chamber (Figure 3-2). For high temperature applications using insulation jackets and alternate mounting approach is used (Figure 3-3). In addition, alternative switch technologies, such as vibrating forks and thermal dispersion switches require an independent process connection (chamber penetration). (Figure 3-4).

For limit switches not factory assembled to the KM26 chamber, the following informational guidelines have been provided for limit switch installation. Please refer to the specific application switch manual for complete steps and procedure for proper installation.

Figure 3-2

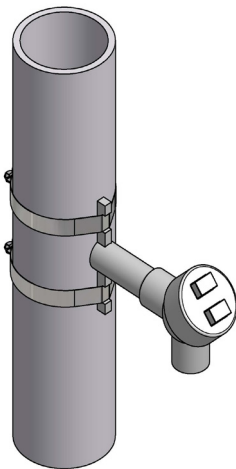

Figure 3-3

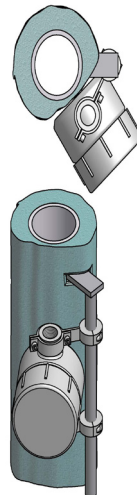
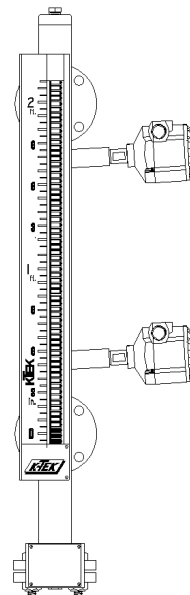

Figure 3-4



For limit switches not factory assembled to the KM26 chamber, the following informational guidelines have been provided for limit switch installation. Please refer to the specific application switch manual for complete steps and procedure for proper installation.

### 3.3.2 General Installation Guidelines

**WARNING:** Ensure the circuit is dead while installing the switch.

1. Mount the switch to the chamber at the desired trip point. Connect or terminate wiring to the switch according to the application. Refer to the switch manual wiring diagram.
2. The KM26 float must be cycled past the switch in both directions to ensure the switch will operate properly when put in service.
3. All field wiring that is connected to a K-TEK limit switch must comply with the National Electric Code.
4. Reference the insulation section of this manual for installing and dismantling insulation jackets.
5. KM26 chambers can be supplied with factory installed insulation jackets or insulation pads. Magnetically actuated switches can be mounted in two different configurations.
  - a. If an insulation jacket is used, rod mount brackets are required.
  - b. If insulation pads are used, stainless steel gear clamps are required.
6. These adjustable brackets and clamps allow re-positioning this switch at any point along the measuring range of the level gauge. Note: Insulation jacket pads are intended to wrap only the KM26 chamber, not the limit switches themselves. (Figure 3-5 and Table 3-1)

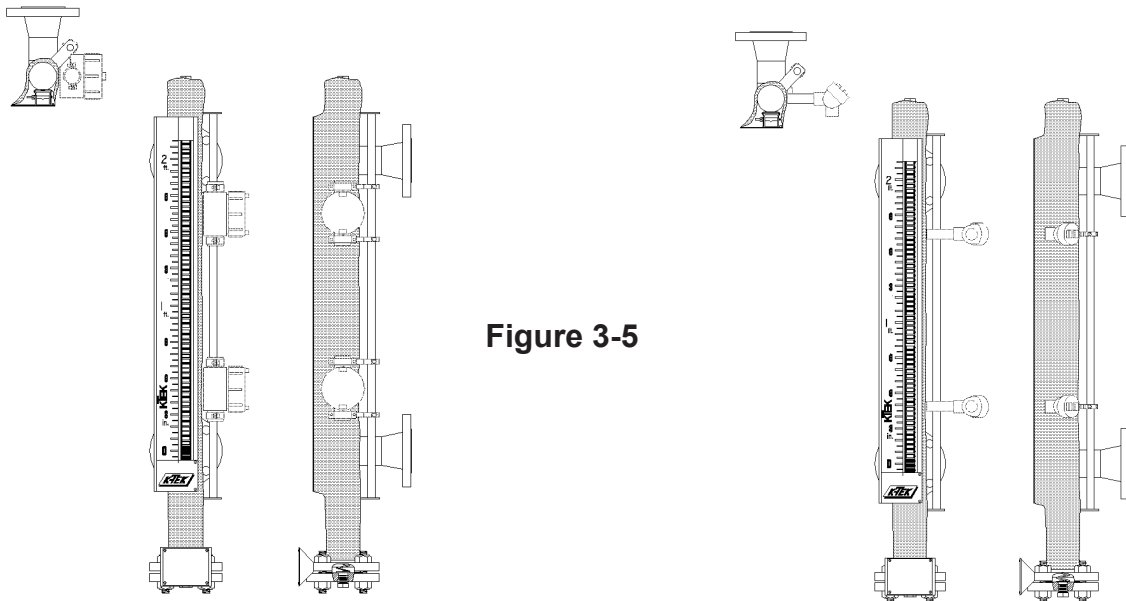

**Figure 3-5**

7. Any conduit or fittings connected to a K-TEK magnetically actuated limit switch should be constructed of aluminum or other non-ferrous material. This is necessary to avoid interference with the operation of the KM26 float or the associated switches.
8. Multiple switch models can be used on a single KM26.
9. Two magnetically actuated limited switches can be mounted so that they may trip at the same point or at two different points separated by less than the length of the switch.
10. Limit switches can not be within 1" of the upper and lower process connections because the float must travel past the switch. Process connections, gussets, support brackets, etc. may interfere with installation at desired locations. Cam actuated switches must be mounted in the correct orientation.

**WARNING:** If there is a need to take the switch out of service or disconnect it for any reason, ensure the circuit is dead or that the area is known to be non-hazardous.



### 3.4 Magnetostrictive Transmitter Installation

Use the following steps to successfully install a Magnetostrictive Level Transmitter (MLT) on an existing Magnetic Level Gauge (MLG). Read all directions carefully before performing any operation. The common mounting location of the transmitter will be on the left hand side of the gauge (when facing the scale) at 90° from the scale.

#### A. If the MLG does not include an insulation blanket or the transmitter does not include an insulation pad:

1. Identify the name tag of the transmitter and based upon the model number determine the proper orientation of the electronics housing.
  - A. AT200
    1. The model number will appear as AT200/B/... or /BW/... to identify electronics housing mounted on the bottom of the probe.
    2. The model number will appear as AT200/T/... or /TW/... to identify electronics housing mounted on the top of the probe.
  - B. AT600
    1. The model number will appear as AT600/B/... to identify electronics housing mounted on the bottom of the probe.
    2. The model number will appear as AT600/T/... to identify electronics housing mounted on the top of the probe.
2. Compare the measuring length of the transmitter (the last numbers in the model number) with the measuring length of the MLG and the center to center dimension of the MLG to determine if the transmitter should match the scale measurement or the center to center of the process connections.
3. Identify the "Factory Zero Mark" sticker on the sensor tube of the transmitter.
4. Block the MLG from the process.
5. Drain the MLG following plant procedures for pressure relief and disposal of process fluids.
6. Align the magnetostrictive transmitter with the MLG.
  - A. If the transmitter measuring length matches the measuring length of the gauge, align the zero mark with the zero of the scale.
  - B. If the transmitter measuring length matches the center to center of the gauge, align the zero mark with the center of the bottom process connection.
7. Mark the MLG chamber where the mounting tabs of the transmitter match up to the chamber. Also, place a mark on the MLG chamber that corresponds to the mounting tabs of any support bracket included with the transmitter.
8. Set the transmitter down.
9. Slightly loosen all but the uppermost worm gear clamps which attach the scale assembly to the MLG.
10. Open the worm gear clamps included with the magnetostrictive transmitter and slide one clamp beneath the scale assembly at each marked location on the MLG. Tighten the clamps slightly to hold them in place.

*Note: For transmitters with a measuring length longer than 7 feet (2.1 meters), use a tape measure to determine the location of mounting tabs on the transmitter and mark the MLG accordingly.*
11. Realign the zero mark of the transmitter with the corresponding zero on the MLG.
12. Starting with the highest transmitter mounting clamp, loosen each transmitter clamp, slide the clamp over or through the mounting tab of the transmitter, and tighten the clamp.
13. Repeat step 12 until all transmitter mounting clamps are tightened.
14. Tighten all scale mounting clamps being sure to align the scale vertically on the MLG.
15. To confirm the zero of the transmitter, apply power to the terminal strip of the magnetostrictive transmitter. If the transmitter reads higher than "zero", raise the transmitter. If the transmitter reads lower than "zero", lower the transmitter.
16. Attach proper field wiring to the transmitter according to the instruction manual, included with the transmitter.
17. Open the process to the MLG using the procedure included in Section 3.6.

## 3.4 Magnetostrictive Transmitter Installation (continued)

### B. If the MLG has an insulation blanket:

**Warning:** Do not mount the transmitter sensor tube beneath the insulation blanket.

Follow steps 1-6 in section A above and use the following alternate steps:

7. Mark the outside of the insulation blanket where the mounting tabs of the transmitter match up to the chamber. Also, place a mark on the insulation blanket that corresponds to the mounting tabs of any support bracket included with the transmitter.
8. Set the transmitter down.
9. Using a razor, cut slots in the insulation blanket 3/4" wide and 1" long (19mm x 25mm) at each mark.
10. Loosen the insulation blanket from the scale assembly opposite the location of the transmitter and slightly loosen all but the uppermost worm gear clamps which attach the scale assembly to the MLG.
11. Open the worm gear clamps included with the magnetostrictive transmitter and slide one clamp beneath the scale assembly at each marked location on the MLG insulation blanket. Tighten the clamps slightly to hold them in place.
 

*Note: For transmitters with a measuring length longer than 7 feet (2.1 meters), use a tape measure to determine the location of mounting tabs on the transmitter and mark the MLG insulation blanket accordingly.*
12. Realign the zero mark of the transmitter with the corresponding zero on the MLG.
13. Starting with the highest transmitter mounting clamp, loosen each transmitter clamp, slide the clamp over or through the mounting tab of the transmitter, and tighten the clamp.
14. Repeat step 13 until all transmitter mounting clamps are tightened.
15. Tighten all scale mounting clamps being sure to align the scale vertically on the MLG and reattach the insulation blanket to the scale assembly.
16. To confirm the zero of the transmitter, apply power to the terminal strip of the magnetostrictive transmitter. If the transmitter reads higher than "zero", raise the transmitter. If the transmitter reads lower than "zero", lower the transmitter.
17. Attach proper field wiring to the transmitter according to the instruction manual, included with the transmitter.
18. Open the process to the MLG using the procedure included in Section 3.6.

### If the transmitter includes an insulation pad:

Follow steps 1-17 in section A. Before mounting the transmitter:

1. Align one end of the insulation pad with the end of the transmitter sensor tube.
2. Mark the insulation pad at the location of each transmitter mounting tab.
3. Using a razor, cut slots in the insulation pad 3/4" wide and 1" long (19mm x 25mm) which correspond to the marks from the mounting tabs.
4. Mount the insulation pad between the transmitter sensor tube and the MLG.
5. The transmitter mounting tabs will hold the insulation pad in place.

## 3.5 Isolation Valves

Valves should be installed between the tank and the KM26 for maintenance purposes and are available as an option.

**CAUTION**



Care must be used when opening the valves to prevent a surge of fluid or gases through the chamber. A surge can cause the float to be propelled against the far stop causing damage to the float shell and/or the indicator glass. Failure to comply may result in damage to the float and expense to the customer. Gradually open the upper isolation valve prior to the lower one to equalize the pressure in the level gauge chamber with the pressure in the vessel. After the pressure has equalized, gradually open the lower isolation valve.

At this point, the level indicator may show a liquid level if enough liquid is present.

### 3.6 Pressure Testing



The level indicator chamber should be blocked off or the float should be removed when the vessel is hydrostatically tested. This precaution is necessary because most vessels are tested at pressures much higher than the maximum operating pressures and, even though the float chamber is capable of the high pressures, the float may not be capable

of handling such pressures. **All units are clearly marked as to this danger and should be given special consideration.** Failure to comply may result in damage to the float and expense to the customer.

### 3.7 Insulation

Chamber, switch, transmitter, and flange insulations are available as an option or, to meet the temperature requirements specified. These coverings protect the process, personnel, and/or equipment from temperature extremes. The customer may elect to install their own insulation. When this is done, care must be exercised to insure that associated equipment (i.e. scales, switches, transmitter, etc) remains in proximity to the float magnets and that the insulation does not adversely affect the devices in terms of temperature retention.

### 3.8 Scale Zero

Scale zero (lowest measure point on the ruler) for the KM26S is typically at the centerline of the lower side process connection or 10" from the face of the bottom flange. This varies with specific gravity requirements or custom designs. The KM26T zero point is typically 6" to 10" from the face of the process connection unless some special requirement calls for a change. In any case, the scale zero point coincides with the float at the lowest point in the chamber. The scale is installed so that the indicator just begins to move when the float is against the bottom stop.

### 3.9 Replacing Indicator Tube

1. Remove the machine screw in the upper tube holder. Remove the upper tube holder by sliding it out of the end of the channel (do not pull forward). For units 60" or longer remove all of the stainless steel wires that retain the tube in the channel. Slide the tube to be replaced out of the end of the channel.
2. Before installing replacement tube, check for proper orientation. The bottom of the shuttle tube will have an orange "PAC-MAN" shaped silicon bumper inside the tube. The bottom of the magnetic bar graph glass tube will have an indentation to align with the bottom tube holder. Insert the replacement tube into the bottom holder. Install the top holder using the machine screw to hold in place. Replace any stainless steel wires necessary to retain the tube in the channel.
3. Cryogenic Indicator tubes are sealed into the scale assembly and should be replaced as a unit. These scale assemblies are strapped in place using gear clamps.

### 3.10 Insulation Instructions



EDGES OF THE SCALE ASSEMBLY CAN BE SHARP. GLOVES AND PROPER CARE ARE REQUIRED WHILE WORKING!

The installation of insulation on KM26 units is dependent upon the process temperatures and type of indicator used. All temperatures referenced in insulation instructions refer to process temperatures. For design temperature under 200°F, no insulation is required. If ordered, the insulation will be a Tied-on Blanket (Standard Insulation attached to the scale assembly). For 300°F to 450°F, an Insulation Pad is required for magnetic bargraph (MBG) indication. If chamber insulation is ordered in lieu of insulation pad, then the insulation will be a Pipe Wrap Blanket. For 450°F to 500°F, Pipe Wrap Blankets are mandatory for MBG indication. Before installing any blanket or pad, note the location of all chamber accessories to ensure a return to the proper working location. Some units are built with limited accessory locations and the accessories may not function if moved to new location.

### 3.10.1 Insulation Pads

To install insulation pads, simply remove the accessory from the unit. Set the accessory on the pad. Using a razor, cut a hole through the pad wherever a bracket or clamp exists. Push the brackets or clamps through the hole and re-attach the accessory to the previous location. Verify proper operation and location.

The insulation thickness of a blanket is determined by the process temperature. In all locations where scale indications, switches, and transmitters are located, the insulation thickness is thinned to 1/2" to facilitate magnetic coupling. For all other locations the insulation thickness is governed by the following:

- 0 – 250°F (0 – 121°C) 1/2" thickness ceramic fiber filler with inner and outer silicone impregnated cloth covering
- 251 – 500°F (122 – 260°C) 1" thickness ceramic fiber filler with inner and outer silicone impregnated cloth covering
- 501 – 850°F (261 – 454°C) 1" thickness ceramic fiber filler with outer silicone impregnated cloth covering and 4-ply high temp liner including TempKoat™ insulation
- 851 – 1000°F (455 – 538°C) 2" thickness ceramic fiber filler with outer silicone impregnated cloth covering and 4-ply high temp liner including TempKoat™ insulation

For insulated units, it is critical to know the location of all components attached to the unit when ordering the insulation. Typically, the scale is located opposite to the process connections and the insulation will be thinned down to 1/2" on that side (or have no insulation at all if a Tied-on Blanket). If the scale has been moved from the position that it is shipped in, then the thinned insulation will not be in the correct location. When ordering, K-TEK refers to location by a clock system with the process connections at 12 o'clock when looking down on the unit from above. The scale is typically at 6 o'clock. Openings for the connections are made on the basis of the orientation specified by the customer. Thinning of insulation is needed for switches and transmitters as well and their positions must also be known.

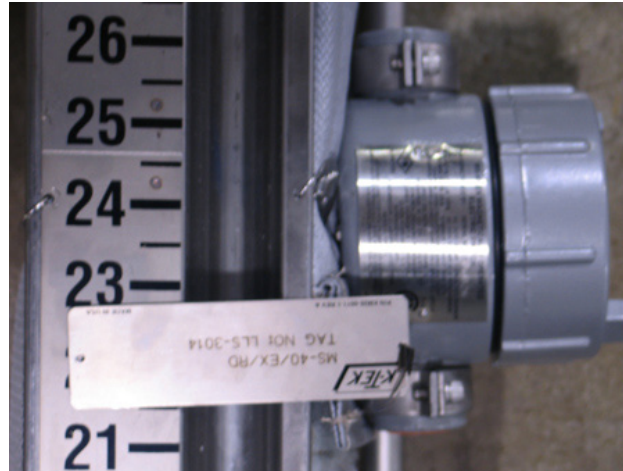

**Switch Location**

### 3.10.2 Tied-On Blanket

For a Tied-on blanket, installation requires that the channel for the scale be drilled to accommodate the wire lacing needed to hold the blanket in place. If not already done for prior insulation, then each side is to be drilled. This is best done with the scale removed from the unit and the indicator removed from the scale channel. Drill 1/8" diameter holes in the upper and lower corners of the channel (this will require drilling through the ruler and logo). Starting from the top of the scale channel and work to the bottom drilling holes at 6" centers. For spacing between bottom corners and last hole, split the difference or omit if unnecessary. Re-install the scale and indicator assembly on the original location. Place the blanket around the process connections and strap any velcro straps into place above and below the scale. If a switch mount rod has been installed, cut-outs with velcro closures should have been provided at standard locations. If not, mark the locations of the brackets where they hit the insulation. Sew around the area needing to be cut for the brackets and then cut the insulation at that point to allow the brackets to be cleared. If a transmitter is installed, note its location and undo the front of the brackets (not the gear clamps) and remove the transmitter. Hold the insulation against the pipe so that it is in its installed position and feel for the brackets beneath the blanket. Mark the location of the brackets with a marker. Sew a 1" square through the blanket around the marks. Using a razor, cut an X from corner to corner of the square making sure not to break the new seam. Push the brackets through the new holes. Lacing anchors and washers should have been provided with the blanket. Pull the blanket to the scale where it will rest when installed. Locate the holes on the scale and press the lacing anchor wire through the insulation about 1" from the insulation edge aligned with the holes



(\*\*USE CAUTION WHEN PERFORMING THIS SO AS NOT TO INJURE YOURSELF WITH THE WIRE\*\*).

Place a washer over the wire, compress the insulation, and bend the wire to secure the anchor in place. Plain wire pieces should have also been provided. Bend them in half and place into the hole on the scale. Lay each half of the bent wire on opposite sides of the anchor hook. Using pliers (end cutting wire nippers are recommended), grab both halves of the wire and twist the wire capturing the hook in the formed loop of wire. Repeat this process until all holes are used to anchor the insulation. Go back to each wire and tighten each wire into tight spirals under the hook. Cut off any part of the twist exposed to protect personnel from scratch injury. Repeat this process for the opposite side of the scale.

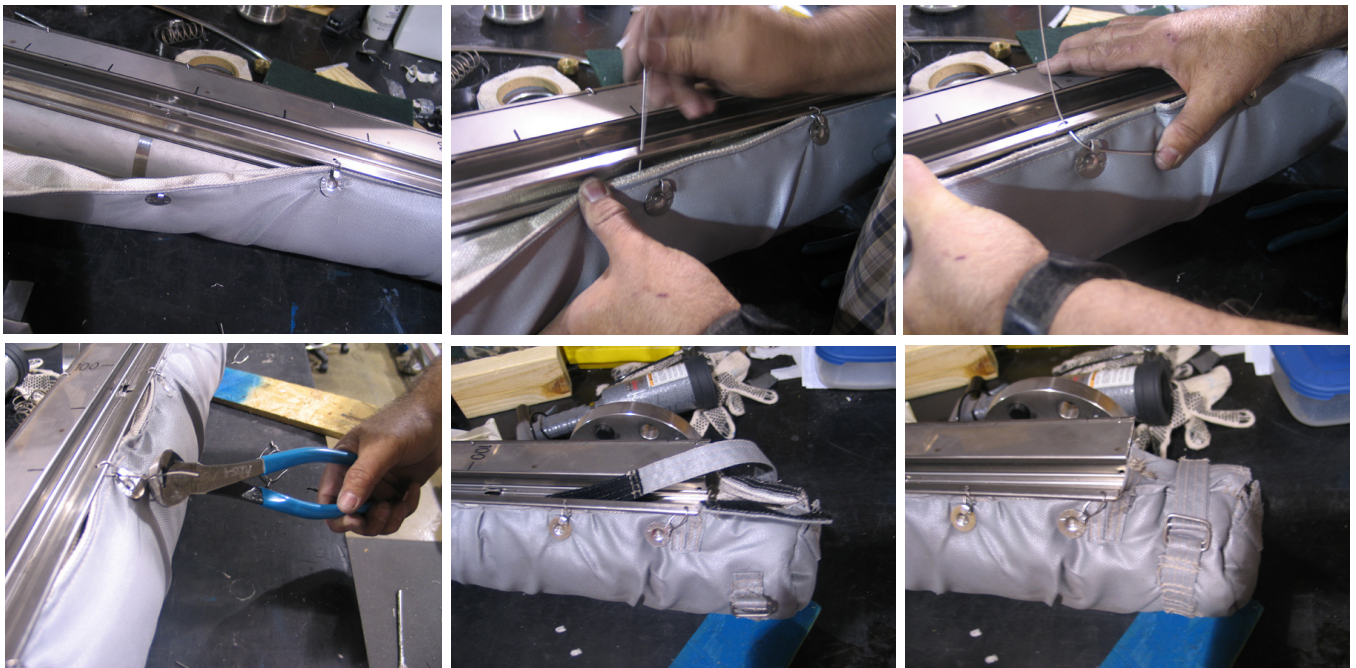

### 3.10.3 Pipe Wrap Blanket

For Pipe Wrap Blankets, installation requires the removal of scale assembly and transmitter (if installed). If a transmitter is installed, note its location and undo the front of the brackets (not the gear clamps) and remove the transmitter. Switches on switch mount rods will have to be rotated away from the chamber. Wrap the insulation blanket around the unit and fasten it with the Velcro straps. If a transmitter was installed, feel for the brackets under the insulation and mark their location with a marker. Sew a 1" square through the blanket around the marks. Using a razor, cut an X from corner to corner of the square making sure not to break the new seam. Push the brackets through the new holes. Set the scale assembly against the insulation at proper mounting location. Draw a mark on each side of each gear clamp next to the scale channel. This location on the insulation should have sewn seams down the length of the blanket to prevent fraying. It is recommend that the marks for each clamp be sewn around to reduce fraying. Using a razor, cut through the insulation to allow the gear clamp to pass through the hole. Once a hole is made for each clamp, remove the blanket from the unit. Feed the gear clamps of the scale assembly through the holes so that each end of the clamp goes through. Set the scale assembly and insulation blanket against the unit and use the gear clamps to fasten the parts to the unit. Make sure that the screw for the clamp does not interfere with the transmitter or switch locations. If applicable, feed the brackets for the transmitter through their holes in the blanket. Attach the Velcro closures on the back of the blanket. Rotate any switches back into position. Re-attach the transmitter at the proper location. Verify the operation of all devices. An inoperative switch may need to be pressed tighter to the unit. Transmitters should be checked for the correct zero point and slid up or down to set to proper level.

Side View of Pipe Wrap



Front View of Pipe Wrap

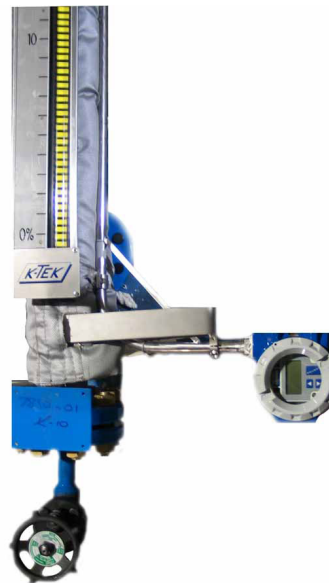

### 3.10.4 Cryogenic Insulation

K-TEK does not recommend **customer installation** of cryogenic insulation. Pictured at right is a K-TEK constructed cryogenic insulation chamber.



CONSULT THE FACTORY!

## 4.0 Troubleshooting

### 4.1 Indicator Decoupling

#### Causes:

- Float is upside down. Remove, check field strength of magnets, and install correctly. Proximity to opposing field may weaken magnetic field.
- Scale assembly is not flat against the chamber due to missing straps. Magnetic field strength drops exponentially with distance. Add gear clamps to eliminate channel separation from chamber. Add stainless steel retaining wires to eliminate indicator tube separation from channel.
- Float stop springs have been bent or broken. Adjust or replace springs as needed to prevent float travel outside the range of the indicator tube.
- Scale has been moved allowing float travel outside of range or causing too much separation from the float. Reposition the scale.
- Float or indicator de-magnetizing by proximity to other magnetic material, high temperature, or repulsive fields. Consult factory for re-magnetization of float or replace the float and/or indicator and remove the source of demagnetization. Sources include floats and switches installed upside down, close ferrous materials, nearby magnetic fields, magnetic particles from process piping, etc.
- Indicator tube is no longer sealed and contains moisture or dirt. This increases friction inside the tube. Replace the tube.
- Chamber is not vertically level causing increased friction between the shuttle and glass and increased distance between the float and the scale assembly. Adjust the position of the chamber.
- Indicator tube incorrectly installed. See directions for installation.
- Magnetic particles from the process fluid stuck to float. This distorts the magnetic field and changes the float buoyancy. Remove and clean float and install magnetic traps in the process connections.
- If for some reason, magnetic coupling is lost, it can be restored by following three simple steps.
  1. Using a permanent magnet, locate the float inside the chamber.
  2. Take the permanent magnet and raise the follower to the same level as the float.
  3. Remove the magnet to the side as quickly as possible to set the follower in a spinning motion.

### 4.2 Float Sinks or Sticks

- Process specific gravity is lower than was specified at the time of order. Identify true minimum specific gravity requirements considering temperature and pressure variations and order new float providing minimum and operating specific gravity.
- Magnetic particles in the process fluid have become attached to the float changing its buoyancy. Install magnet traps in the process connection lines, then clean and reinstall float.
- Solidification of process fluids on the surface of the float have changed its buoyancy. Consider replacing with a Teflon "S" coated float, heat tracing the chamber to decrease solidification, or reduce the amount of solidifying particles in the chamber.
- Solidification of process fluid on the interior of the chamber has decreased the clearance for the float. Consider replacing with a coated chamber, heat tracing the chamber to decrease solidification, or reduce the amount of solidifying particles in the chamber.

### 4.3 Switch Does Not Work

- Switch installed upside down. Remove and install correctly.
- Float does not travel past the switch during operation. Float may encounter float stop prior to activating switch. Switch point should be a minimum of 1" inside the upper and lower stop points for the float.
- Contacts damaged due to excessive load, inductive load, or dead short in the circuit. Replace the switch.
- Magnet has been demagnetized by proximity to magnetic source or ferrous materials. Replace the switch and remove the interference. (continued on next page)

- Distance between the switch and float is too large. Strap may be loose, insulation may be too thick, attachment to a switch mount rod may have moved or the switch has been moved away from the location of a guided float.
- Float has become demagnetized and indicator also decouples readily. Have the float re-magnetized at the factory and remove the source of demagnetizing.

## 5.0 Parts Ordering

K-TEK can provide custom fit insulation for most installations. Contact the factory for details. Each KM26 is built to the customer's specifications, which makes parts for these units unique. Each unit is given a serial number to provide K-TEK a means to track exactly how the unit was constructed. To order parts, specify the KM26's serial number and the part number suffix shown on the drawings that follow.

**\*\*NOTE\*\*** Refer to parts drawing on page 17-18 for the part number.

Example: To order a scale for the KM26 show:  
(Part number = Serial # - 1C)  
Part # 0510-9999-01-1C

**Important Note!** Floats are subject to change with customer requirements and only the last float provided is the float of record (previous versions are voided). Changes to float requirements when ordered then become the float of record. These changes in float design may also require the customer to adjust the float stop springs to account for changes in float length and magnet position. Estimates of the necessary changes can be provided at quotation and final dimensions will be provided once the final float design is confirmed by Applications Engineering.

## 6.0 Customer Specific Product Information

Use this area to record pertinent information about your purchased unit.

Serial Number \_\_\_\_\_

Process Fluid \_\_\_\_\_

Process Temperature \_\_\_\_\_

Process Pressure \_\_\_\_\_

Fluid Specific Gravity (SG) \_\_\_\_\_

Tag # \_\_\_\_\_



## 7.0 Appendix A

### 7.1 KM26S Parts Breakdown Drawing

ITEM	DESCRIPTION	PART NO.
1	SCALE ASSEMBLY (INCLUDES 1-ABC)	Ser. No. - 1
1A	TUBE WITH FOLLOWER	Ser. No. - 1A
1B	TUBE HOLDER	Ser. No. - 1B
1C	SCALE	Ser. No. - 1C
2	KM-26S CHAMBER	Ser. No. - 2KS
3	VENT PLUG	Ser. No. - 3KS
4	GASKET	Ser. No. - 4KS
5	FLOAT CHAMBER CLOSURE	Ser. No. - 5KS
	FLANGE WITH SPRING	
6	KM-26S FLOAT	Ser. No. - 6KS
	SPECIFY TOTAL OR INTERFACE(I) IF BOTH EXIST	
	Ex. Ser No. - 6KS(T OR I)	
7	DRAIN PLUG	Ser. No. - 7KS

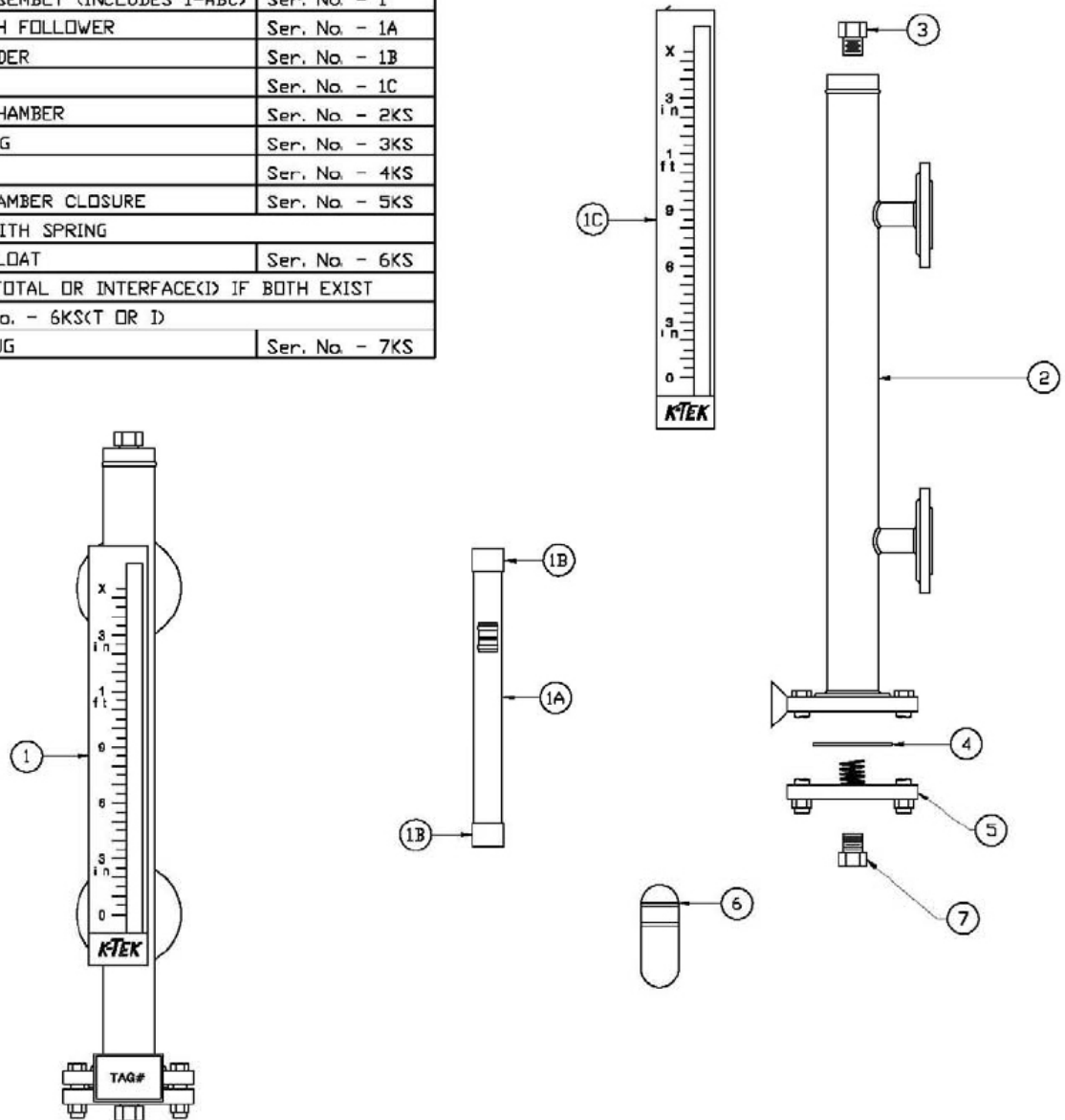

## 7.0 Appendix A

### 7.2 KM26T Parts Breakdown Drawing

ITEM	DESCRIPTION	PART NO.
1	SCALE ASSEMBLY (INCLUDES 1-ABC)	Ser. No. - 1
1A	TUBE WITH FOLLOWER	Ser. No. - 1A
1B	TUBE HOLDER	Ser. No. - 1B
1C	SCALE	Ser. No. - 1C
2	KM-26T CHAMBER	Ser. No. - 2KT
3	FLOAT STOP TUBE	Ser. No. - 3KT
4	FLOAT STOP PLATE	Ser. No. - 4KT
5	SNAP RING	Ser. No. - 5KT
6	KM26T FLOAT	Ser. No. - 6KT
7	GUIDE ROD & MAGNET ASSEMBLY	Ser. No. - 7KT
8	STILLING WELL	Ser. No. - 8KT

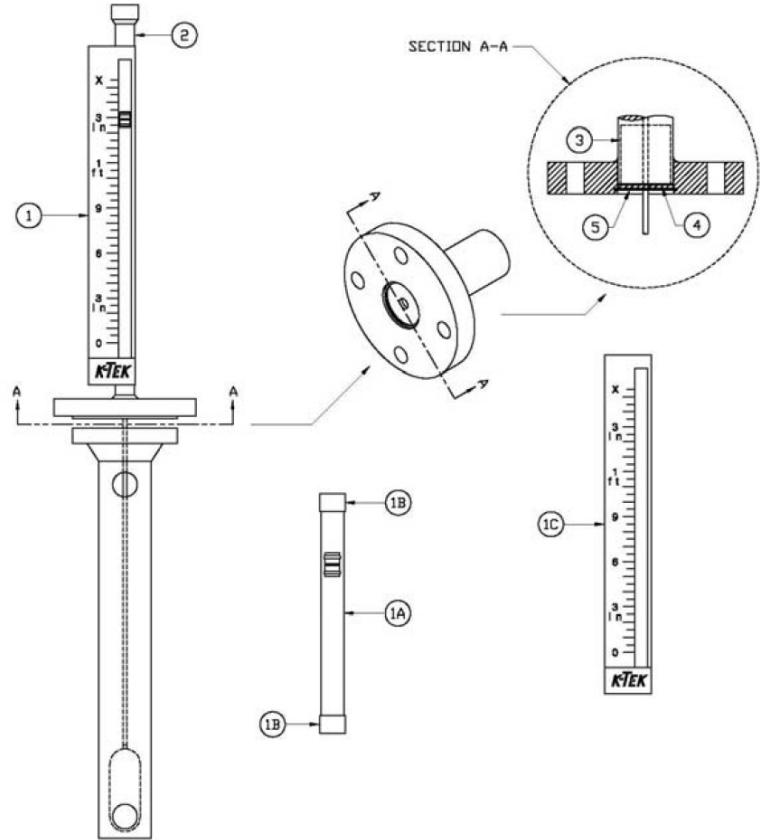
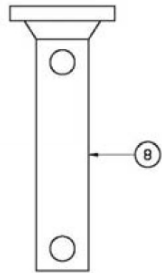
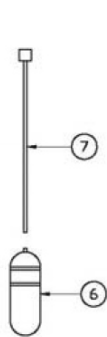
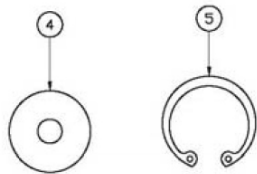

## 8.0 APPENDIX B

### 8.1 Unpacking

Unpack the instrument carefully. Inspect all units for damage. Report any concealed damage to carrier within 24 hours. Check the contents of the packing slip and purchase order. Check and record the serial number. This can be used to reference when ordering spare or replacement parts for the MLG and/or related accessories.

Note: Do not discard the shipping container until all parts/components are verified and checked.

### 8.2 Pre-Installation Checklist

**CAUTION**  If equipment is used in a manner not specified by K-TEK, protection provided by equipment may be impaired.

- Manually move the float from 0% to 100% and back to 0% prior to startup/check out in order to reinitialize any switch accessories (only required if magnetically actuated switches are supplied). Switches may inadvertently change state during any rough handling during transport.
- Remove float prior to pressurizing tank/vessel.

**CAUTION**  Float damage may occur if not removed prior to any pressure testing.

- Verify the MLGs center-to-center dimension equals that of the tank/vessel.

### 8.3 Equipment & Tools

- Open-end wrenches or an adjustable wrench to fit the process studs/nuts. A torque wrench is also recommended.
- Flat-blade screwdriver or 5/16" nut driver
- Digital multimeter or digital volt/ammeter if transmitters or switches are attached
- Level
- Gasket for mating flanges
- Teflon tape & "never seize" for threaded units
- Pipe wrench for threaded units
- Alan Wrench (5/32")

### 8.4 Placing an MLG in Service (Startup)

Ensure that the operating conditions (temperature, pressure, and specific gravity, etc) are within the maximum ratings of the MLG. At the bottom area of each MLG is a nameplate that indicates all of the relevant process specifications, serial number, and tag number.

Install the MLG float (this should have been accomplished in pre-installation steps). The float is marked ">>>> UP >>>>" to insure proper orientation when placing float inside chamber. For a KM26T MLG (a top mount style), remove the float and guide rod. For a KM26S MLG (a side mount style), the MLGs are supplied with float start and stop springs. Verify these are installed at top and bottom locations.

The float chamber should be closed with no openings to the atmosphere. Check to see that all drain and vent plugs are securely in place and all vent and drain valves are closed.

**CAUTION**  The following procedural sequence is critical in pressurized applications.

When the MLG is mounted and ready to be applied to the liquid service, the TOP process connection valve should be opened FIRST and should be opened very slowly to allow pressure to equalize. This allows process fluid or vapor to enter the MLG at a slow and controlled rate that is reasonable and ultimately allows the MLG to reach operating pressure and temperature in a safe fashion.

## 8.0 Appendix B

When the MLG has reached process pressure, then the BOTTOM process connection can be opened slowly. Once this is accomplished, the startup procedure has been completed.



Vent or Drain valves should not be used during startup for pressure relief from the process under any circumstances. This has the potential to permanently damage the instrument and is a hazard to personnel.

### 8.5 Removing an MLG from Service

1. Close the BOTTOM process isolation valve to prevent further filling of the MLG. Then close the TOP process connection isolation valve to completely isolate the MLG from the process pressure.
2. Attach proper vapor collection equipment to the MLG vent if required. Open the top vent to relieve pressure in the MLG and allow air to flow when the bottom drain is opened.
3. Attach proper liquid collection equipment to the bottom drain and remove liquid. After all process fluid is completely drained, the MLG is ready to be removed from service.

### 8.6 Maintenance

1. Most KM26 MLGs are supplied with ½” vent and drain plugs (and associated valves) in the top and bottom of the float chamber to allow cleaning and removal of the process fluid as required. MLGs should be cleaned and inspected based on the severity of the service.

To perform cleaning procedure:

- A. Block in the float and chamber with the process connection isolation valves or ensure the associated vessel/tank is empty or out of service. Follow steps outlined in “Removing an MLG from Service”.
  - B. Following a complete fluid drain from the MLG, remove the drain flange and allow the float to slide out of the chamber bottom. Be sure to examine the float for any excessive wear and clean as needed.
  - C. Clean the chamber inside wall with a bottle brush or scrubbing tool. Some processes may require a solvent of some type for cleaning.
  - D. If the MLG is located where the bottom drain is near the floor or other equipment where it is difficult to reach, it is possible to configure an instrument with the top flange in place of a standard weld cap/ vent plug. This allows the MLG to be cleaned and serviced through the chamber top end.
2. After cleaning the MLG chamber, replace the float and drain flange. A new flange gasket may be required.
  3. Note: Use gaskets compatible with process fluid.
  4. Verify that the stainless steel pipe/gear clamps are tight and ensure that the scale assembly has the “positive zero” in the correct location relative to the chamber and float.
  5. Use a permanent magnet or KTEK magnet tool to attract the “shuttle” until it is again coupled to float inside the chamber. (This step is not required if a magnetic bargraph type indicator is utilized.)
  6. Magnetic Traps are available to reduce magnetic particulate travel from the tank/vessel to the chamber. Consult the K-TEK factory for ordering information and configuration details.

### 8.7 MLG Replacement/Spare Parts

When ordering replacement or spare parts for a KM26 MLG, the following information is a minimum requirement:

Serial Number

Item Description

#### 8.7.1 Typical Float Chamber Parts (reference Appendix A for complete parts list)

- Vent and Drain Plug
- Drain Flange & Spring
- Float
- Vent Flange and Spring

#### 8.7.2 Typical Indicator Assembly Parts (reference Appendix A from complete parts list)

- Scale/Channel Assembly
- Indicator Tube (glass or polycarbonate)
- Stainless Steel Gear Clamps
- Name Plate
- Indicator Tube Holders (top & bottom)

## 8.8 Replacement Glass Installation Procedure (Retrofit or Replacement)

### 8.8.1 KM26 Shuttle Replacement Glass Installation Procedure (refer to Figures 8-1 and 8-2)

1. Remove old glass tube and tube holders from scale.
2. Assemble new bottom tube holder to scale using a #6-32 machine screw. Note the orientation of grooves in tube holder that interface with matching feature on scale channel.
3. Insert tall rubber bumper into bottom tube holder. The flat face on tall rubber bumper should rest flat in holder cavity.
4. Carefully align replacement glass with shuttle indicator into scale channel and lower into bottom tube holder. Ensure the glass tube rests flat on rubber bumper and is firmly seated. The nipple on bottom end of glass tube should protrude through the slot in the rubber bumper.
5. Place rubber bumper on top of glass tube.
6. Align top tube holder with scale channel and slide down until top surface of the holder is flush with top of scale channel. The screw hole should align with the hole in the holder.
7. Use a #6-32 machine screw to lock top tube holder in place.
8. Tighten nut and install a second nut to lock tube holders in place.

### 8.8.2 KM26 Magnetic Bargraph Glass Installation Procedure (refer to Figures 8-3 and 8-4)

1. Remove old glass tube and tube holders from scale.
2. Assemble new bottom tube holder to scale using a #6-32 machine screw. Note the orientation of grooves in tube holder that interface with the matching feature on the scale channel.
3. Insert one (1) rubber bumper into the bottom tube holder. The rubber bumper should rest flat in the holder cavity.
4. Carefully align new glass with bargraph indicator into scale channel and lower into the bottom tube holder. The flat faces on the glass tube should register with the corresponding flat faces in the cavity of the bottom tube holder. Ensure that the glass tube rests flat on the rubber bumper and is firmly seated. The nipple on the bottom end of the glass tube should protrude through the slot in the rubber bumper.
5. Place one (1) rubber bumper on the top of the glass tube.
6. Align the top tube holder with scale channel and slide down until the top surface of the holder is flush with the top of the scale channel. The screw hold should align with the hold in the holder.
7. Use a #6-32 machine screw to lock the top tube holder in place.
8. Tighten nut and install a second nut to lock tube holders in place.

## 8.9 KM26 Shuttle Replacement Glass Installation Procedure

Figure 8-1

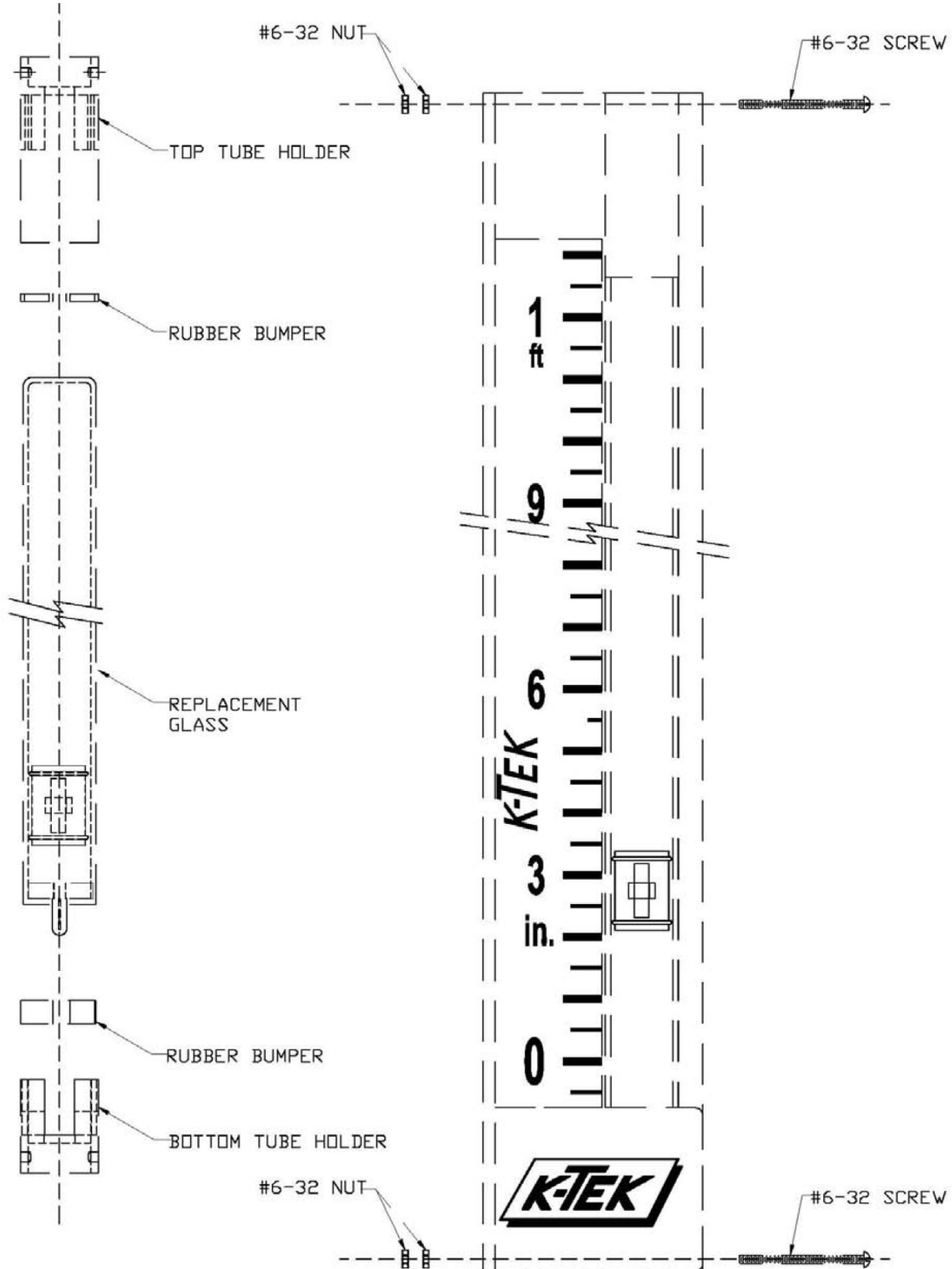

## 8.9 KM26 Shuttle Replacement Glass Installation Procedure

Figure 8-2

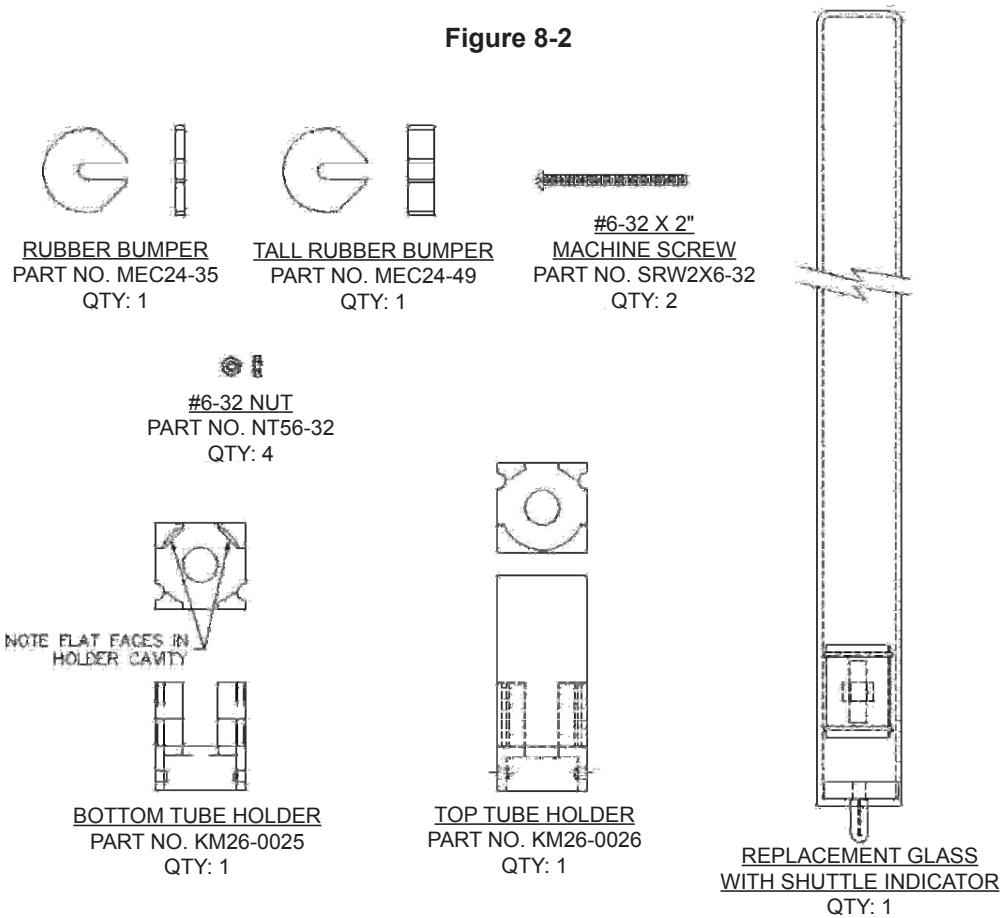

## 8.10 KM26 Bargraph Replacement Glass Installation Procedure

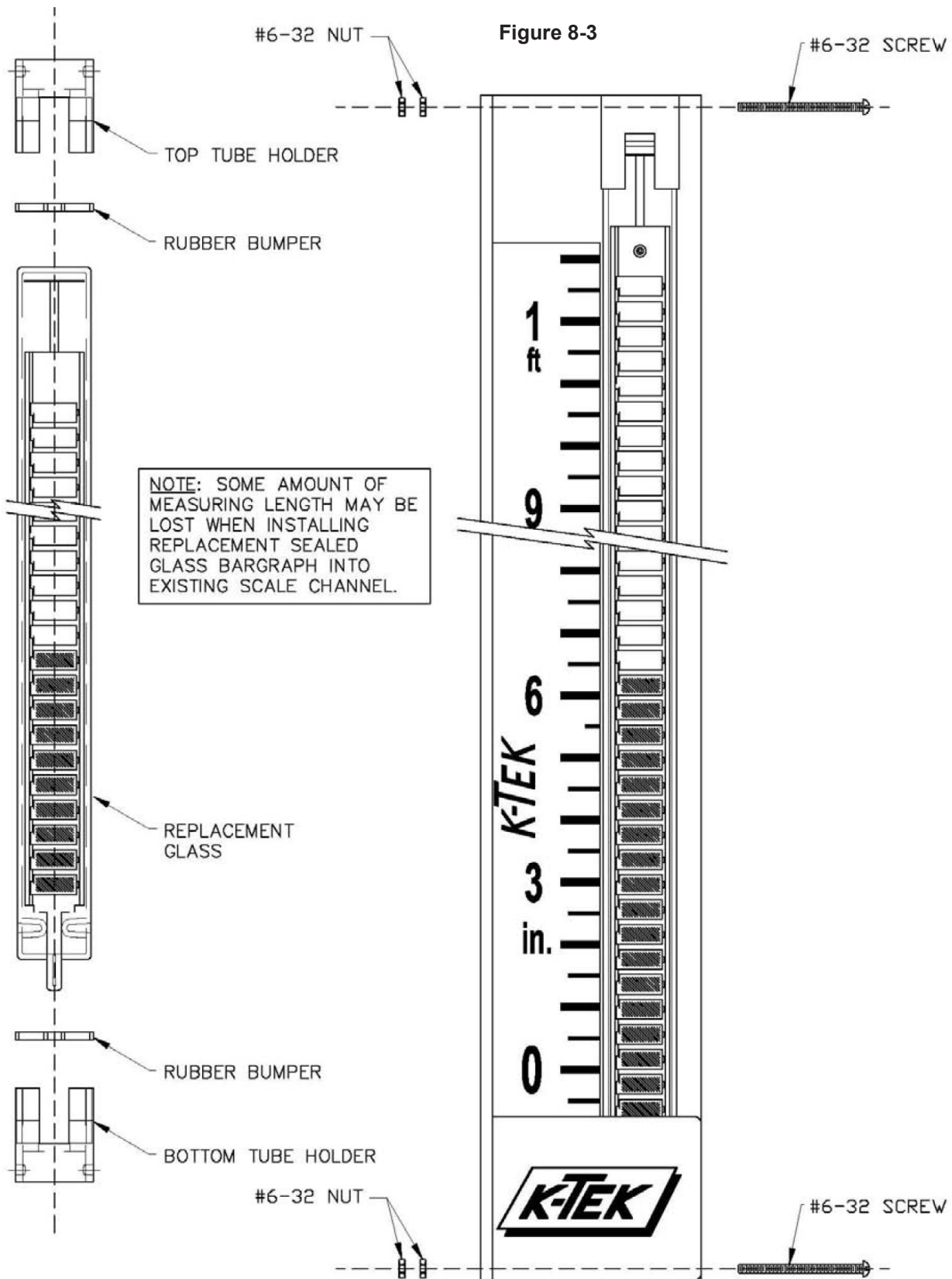



## 8.10 KM26 Bargraph Replacement Glass Installation Procedure

Figure 8-4

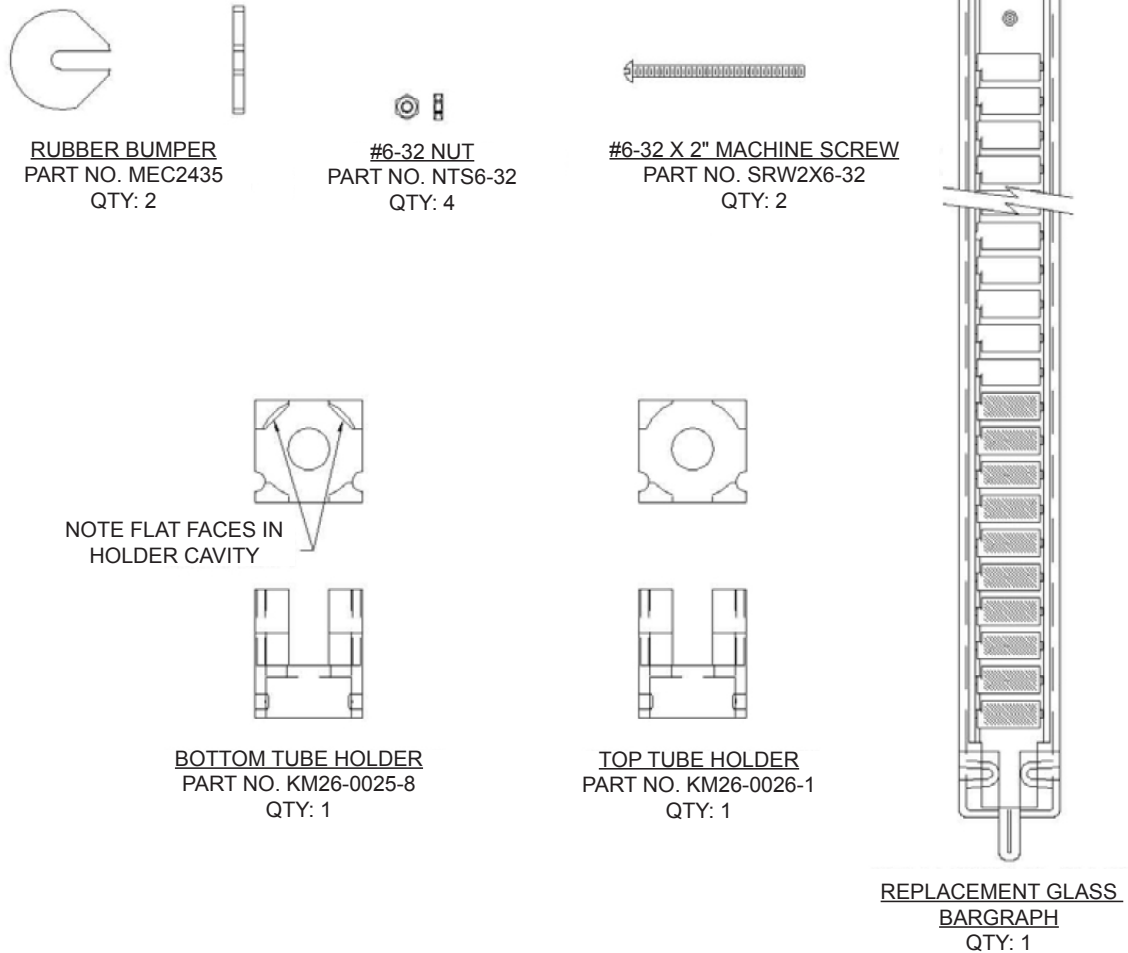

## 9.0 Appendix C

### 9.1 Warranty Statement

#### 5 YEAR WARRANTY FOR:

KM26 Magnetic Liquid Level Gauges; MagWave Dual Chamber System; LS Series Mechanical Level Switches (LS500, LS550, LS600, LS700, LS800 & LS900) (does NOT include switching mechanisms, ie. MS30, MS40, MS41, PS35 & PS45); EC External Chambers, STW Stilling Wells and ST95 Seal Pots.

#### 3 YEAR WARRANTY FOR:

KCAP300 & KCAP400 capacitance switches. BETA Pressure and Temperature Switches have a limited factory guarantee, excluding wetted parts & consumables.

#### 2 YEAR WARRANTY FOR:

AT100, AT100S and AT200 series transmitters; RS80 and RS85 liquid vibrating fork switches; RLT100 and RLT200 reed switch level transmitters; TX, TS, TQ, IX and IM thermal dispersion switches; IR10 and PP10 External Relays; MT2000, MT5000, MT5100 and MT5200 radar level transmitters; RI100 Repeat Indicators; KP paddle switches; A02, A75 & A77 RF capacitance level switches and A38 RF capacitance level transmitters; Buoyancy Level Switches (MS50, MS10, MS8D & MS8F); Magnetic Level Switches (MS30, MS40, MS41, PS35 & PS45).

#### 1 YEAR WARRANTY FOR:

KM50 gauging device; AT500 and AT600 series transmitters; LaserMeter and SureShot series laser transmitters; LPM200 digital indicator; DPM100 digital indicators; APM100 analog indicators; KVIEW series digital indicators and controllers; GRANUPOINT and SLUDGEPOINT vibrating fork switches, SOLITRAK Electro-Mechanical Continuous Measuring Devices, KSONIK ultrasonic level switches, transmitters & transducers, ChuteMaster Microwave Transmitter / Receiver and TiltMaster Switches.

#### SPECIAL WARRANTY CONSIDERATIONS:

K-TEK does not honor OEM warranties for items not manufactured by K-TEK (i.e. Palm Pilots). These claims should be handled directly with the OEM.

K-TEK will repair or replace, at K-TEK's election, defective items which are returned to K-TEK by the original purchaser within the period specified above from the **shipment date** of the item and which is found, upon examination by K-TEK, to its satisfaction, to contain defects in materials or workmanship which arose only under normal use and service and which were not the result of either alterations, misuse, abuse, improper or inadequate adjustments, applications or servicing of the product. K-TEK's warranty does not cover the repair or replacement of units that fail from the effects of excessive vibration unless the units are originally designed for vibration application. In addition, **K-TEK's warranty does not include on-site repair or services**. Field service rates can be supplied on request.

If a product is believed to be defective, the original purchaser shall notify K-TEK and request a Returned Material Authorization before returning the material to K-TEK, with transportation **prepaid** by the purchaser. (To expedite all returns/repairs from outside of the United States, consult K-TEK's customer service team (service@ktekcorp.com) to determine an optimal solution for shipping method and turnaround time.) The product, with repaired or replaced parts, shall be returned to the purchaser at any point in the world with transportation prepaid by K-TEK for best-way transportation only. K-TEK is not responsible for expedited shipping charges. If the product is shipped to K-TEK freight collect, then it will be returned to the customer freight collect.

If inspection by K-TEK does not disclose any defects in material or workmanship, K-TEK's normal charges for repair and shipment shall apply (minimum 250.00 USD). The materials of construction for all K-TEK products are clearly specified and it is the responsibility of the purchaser to determine the compatibility of the materials for the application.

THE FOREGOING WARRANTY IS K-TEK'S SOLE WARRANTY AND ALL OTHER WARRANTIES EXPRESSED, IMPLIED, OR STATUTORY, INCLUDING ANY IMPLIED WARRANTY OF MERCHANTABILITY OF FITNESS FOR A PARTICULAR PURPOSE, ARE EXCLUDED AND NEGATED TO THE MAXIMUM EXTENT PERMITTED BY LAW. NO PERSON OR REPRESENTATIVE IS AUTHORIZED TO EXTEND ANY OTHER WARRANTY OR CREATE FOR K-TEK ANY OTHER LIABILITY IN CONNECTION WITH THE SALE OF K-TEK'S PRODUCTS. THE REMEDIES SET FORTH IN THIS WARRANTY ARE EXCLUSIVE OF ALL OTHER REMEDIES AGAINST K-TEK. K-TEK SHALL NOT BE LIABLE FOR ANY CONSEQUENTIAL, INCIDENTAL, OR SPECIAL DAMAGES OF ANY KIND. K-TEK'S SOLE OBLIGATION SHALL BE TO REPAIR OR REPLACE PARTS (FOUND TO BE DEFECTIVE IN MATERIALS OR WORKMANSHIP) WHICH ARE RETURNED BY THE PURCHASER TO K-TEK.

## 9.2 RMA Form



K-TEK  
 18321 Swamp Road  
 Prairieville, LA 70769  
 Phone: +1 (225) 673-6100  
 Fax: +1 (225) 673-2525  
 Email: service@ktekcorp.com  
 Toll Free: (800) 735-5835

**\*\*\* IMPORTANT CUSTOMER NOTICE: PLEASE READ PRIOR TO RETURNING PRODUCTS TO K-TEK\*\*\***

Be sure to include the Return Authorization (RA) number on the shipping label or package to the attention: Customer Service. A copy of this document should also be included with the packing list. K-TEK wants to maintain a safe work environment for its employees. In the event, the returned product or material has been in contact with a potentially hazardous chemical, per federal regulations, the customer must provide evidence of decontamination and the related chemical composition and characteristics. In order to expedite your return, please include the applicable Material Safety Data Sheets (MSDS) and decontamination tags by affixing these documents in close proximity to the shipment label for identification purposes. (January 18, 2006)

### Return Authorization Form

Customer:	Date:
Contact Name:	Product:
Contact Email:	Serial No:
Contact Phone:	Job No:
Contact Fax:	Service Rep:

### Completed by Customer

Reason:

---

Problem Found: None

Action            None

Requested:

Is expedited return shipping requested?  Yes

*If yes, please provide a purchase order or your shipper's account number (ex FedEx or UPS).  
 K-TEK pays return transport via standard ground shipments only.*

Account #:

**If purchase order is issued, a copy of purchase order must be included with return authorization documentation.**

Is K-TEK authorized to repair items determined to be non-warranty?  Yes

*If yes, a copy of purchase order must be included with return authorization documentation.*

Customer PO#:	Date:
---------------	-------

Has product been in contact with any potentially hazardous chemical?  Yes

*If yes, documentation product and forward MSDS to K-TEK. "ATTN: Customer Service"*

### Return Repaired Product to Address

Shipping Address:	Billing Address:
Ship Via: <input style="width: 100px;" type="text"/>	



For the latest version of this manual, visit [ktekcorp.com](http://ktekcorp.com).

**K-TEK**  
18321 Swamp Road  
Prairieville, LA 70769 USA  
Tel: +(1) 225.673.6100  
Fax: +(1) 225.673.2525  
Email: [service@ktekcorp.com](mailto:service@ktekcorp.com)  
Website: [ktekcorp.com](http://ktekcorp.com)