

GE Healthcare

ÄKTAexplorer

System Manual



Contents

1	Introduction	
1.1	About this manual	9
1.2	General	10
1.3	Safety	14
1.4	Optional configurations	17
2	Operation	
2.1	Columns and tubing	20
2.1.1	ÄKTAexplorer 10 tubing	20
2.1.2	ÄKTAexplorer 100 tubing	20
2.1.3	Recommended tubing and columns – ÄKTAexplorer 10	21
2.1.4	Recommended tubing and columns – ÄKTAexplorer 100	29
2.1.5	Extra system pressure measurement	37
2.2	Sample application overview	38
2.3	Manual filling of sample loops	40
2.3.1	Preparation	40
2.3.2	Partial filling	41
2.3.3	Complete filling	42
2.3.4	Emptying the sample loop	42
2.4	Automated filling of sample loops using Pump P-960	43
2.4.1	General preparation	43
2.4.2	Filling the loop	45
2.4.3	Emptying the sample loop	46
2.5	Mixing gradients	46
2.5.1	Gradients	46
2.5.2	Mixer	46
2.6	BufferPrep	47
2.6.1	What is BufferPrep?	47
2.6.2	Strategy for using BufferPrep	49
2.6.3	Creating a method for pH scouting	49
2.6.4	Preparing the system for a BufferPrep run	50
2.6.5	Fine tuning	51
2.6.6	Creating your own recipes	52
2.7	Collecting fractions	52
2.7.1	Flowthrough fractionation	52
2.7.2	Fixed volume and/or peak fractionation	52
2.7.3	Outlet valve	53
2.8	Before a run	53
2.8.1	Selecting a method	53
2.8.2	Calibrations	54
2.8.3	General preparation	54
2.9	During a run	55

2.9.1	Viewing progress.....	55
2.9.2	Changing parameters.....	56
2.10	Completion of a run and storage	57
2.10.1	Storage.....	57
2.11	Cold room operation	58
2.11.1	Preparation	58
2.11.2	Running.....	58
2.11.3	Removal from cold room.....	59
2.12	Feedback tuning	59
2.12.1	Feedback tuning of the system pump.....	59
2.12.2	Feedback tuning of the sample pump.....	62
3	Maintenance	
3.1	Periodic maintenance	65
3.2	Recycling	65
3.3	Cleaning the system	71
3.3.1	At the end of the day.....	71
3.3.2	Leaving for a few days.....	71
3.3.3	Additional wash of outlet valve and sample valve inlet tubing.....	72
3.3.4	Monthly cleaning.....	72
3.3.5	Cleaning-in-place.....	72
3.4	Moving the system	73
4	Troubleshooting	
4.1	Faults and actions	75
4.2	Recycling	75
4.3	UV curve	76
4.4	Conductivity curve	78
4.5	pH curve	79
4.6	Pressure curve	82
4.7	Monitor UV-900	82
4.8	Monitor pH/C-900	83
4.9	Pump P-900	83
4.10	Mixer M-925	86
4.11	Pump P-960	87
4.12	Valve SV-903	87
4.13	Valve IV-908, PV-908, INV-907	88
4.14	BufferPrep	89
5	Reference information	
5.1	System description	91
5.1.1	The System.....	91
5.1.2	Component locations.....	92

5.1.3	Electrical connections.....	93
5.1.4	Fluid Handling Path – ÄKTAexplorer 10.....	95
5.1.5	Fluid Handling Path – ÄKTAexplorer 100.....	99
5.1.6	Changing tubing kits –ÄKTAexplorer 10.....	101
5.1.7	Changing tubing kits – ÄKTAexplorer 100.....	104
5.2	Components description	107
5.2.1	Pump P-900.....	107
5.2.2	Valve SV-903.....	108
5.2.3	Monitor pH/C-900.....	108
5.2.4	Monitor UV-900.....	108
5.2.5	UV flow cells.....	109
5.2.6	Pump P-960.....	109
5.2.7	Mixer M-925.....	110
5.2.8	Valve INV-907.....	110
5.2.9	Valves IV-908 and PV-908.....	111
5.2.10	Flow restrictors FR-904 and FR-902.....	112
5.2.11	On-line filter.....	112
5.2.12	Fraction collector (optional).....	112
5.3	BufferPrep details	113
5.3.1	Creating your own recipes	113
5.3.2	Defining a new buffer substance.....	114
5.3.3	Defining a new salt.....	114
5.3.4	Correction factors.....	115
5.3.5	Examples and tips.....	115
5.3.6	Recipe overview.....	118
5.4	Technical specifications	120
5.4.1	Operating data.....	120
5.4.2	Physical data.....	123
5.4.3	Hardware requirements.....	123
5.4.4	Software requirements.....	123
5.4.5	Network requirements.....	123
5.4.6	ÄKTAexplorer component materials.....	124
5.5	Chemical resistance guide and chemical compatibility	125
5.6	Accessories, spare parts and consumables	128
	Index.....	137

Important user information

All users must read this entire manual to fully understand the safe use of ÄKTAexplorer.

Important!

ÄKTAexplorer is intended for research use only, and should not be used in any clinical or in vitro procedures for diagnostic purposes.

ÄKTAexplorer should not be used in any clinical or in vitro procedures for diagnostic purposes.

Safety notices

This manual contains warnings and cautions concerning the safe use of the product. See definitions below.



WARNING! The WARNING symbol and notice highlight instructions that must be followed to avoid personal injury. Do not proceed until all stated conditions are clearly understood and met.

CAUTION! The CAUTION notice highlights instructions that must be followed to avoid damage to the product or other equipment. Do not proceed until all stated conditions are met and clearly understood.

Notes

Note: A Note is used to indicate information that is important for trouble-free and optimal use of the product.

Recycling



This symbol indicates that the waste of electrical and electronic equipment must not be disposed as unsorted municipal waste and must be collected separately. Please contact an authorized representative of the manufacturer for information concerning the decommissioning of equipment.



WARNING! This is a Class A product. In a domestic environment, it might cause radio interference, in which case the user might be required to take appropriate measures.



WARNING! All repairs should be done by personnel authorized by GE Healthcare. Do not open any covers or replace parts unless specifically stated in the instructions.

CE-certification

This product complies with the European directives listed below, by fulfilling corresponding standards. A copy of the Declaration of Conformity is available on request.

- 73/23/EEC, Low Voltage Directive
- 89/336/EEC, EMC Directive

The CE logo and corresponding declaration of conformity, is valid for the instrument when it is:

- used as a stand-alone unit, or
- connected to other CE-marked GE Healthcare instruments, or
- connected to other products recommended or described in this manual, and
- used in the same state as it was delivered from GE Healthcare except for alterations described in this manual.

Note: The Declaration of conformity is valid only for systems that are marked with the CE logo:



1 Introduction

1.1 *About this manual*

This manual describes the operation of ÄKTAexplorer™.

System description, system maintenance and trouble-shooting are also found in this manual.

The installation of the chromatography system is described in a separate Installation Guide.

The basic information on how to operate the chromatography system is not provided in this manual. The user must first read the “Making your first runs” booklet to take full advantage of this manual.

Depending on the application, different optional configurations might be required. Information about these options can be found in ÄKTAexplorer Optional Configurations User Manual which describes the extended functions of the ÄKTAdesign systems.

1.2 General

ÄKTAexplorer is a fully automated liquid chromatography system designed for method development and research applications. The system simplifies the transition from laboratory to full scale production. Scale-up to production is predictable and trouble-free.

ÄKTAexplorer features:

- Flow rates and pressures up to:
 - 100 ml/min and 10 MPa in ÄKTAexplorer 100 (P-901)
 - 10 ml/min and 25 MPa in ÄKTAexplorer 10 (P-903)
- BufferPrep for fast pH optimization.
- One working platform for all liquid chromatography techniques suitable for protein purification, from micro-gram to gram scale.



ÅKTAexplorer consists of a compact separation unit and a personal computer running UNICORN™ control system version 4.12 or higher. Fraction collectors are available as accessories.

The systems are described in detail in Section 5.1 of *Reference information* in this manual and brief descriptions of the individual components are given in Section 5.2 of *Reference information*. Detailed information on the components can be found in their respective User Manuals and Instructions. UNICORN control system is described in the separate UNICORN User Manuals. UNICORN is supplied with a Method Wizard for creating methods. The ÅKTAexplorer Making your first runs describes how to create a method using the wizard.

The location of the modules and components included in the standard configuration of the separation unit is shown in the following illustration.

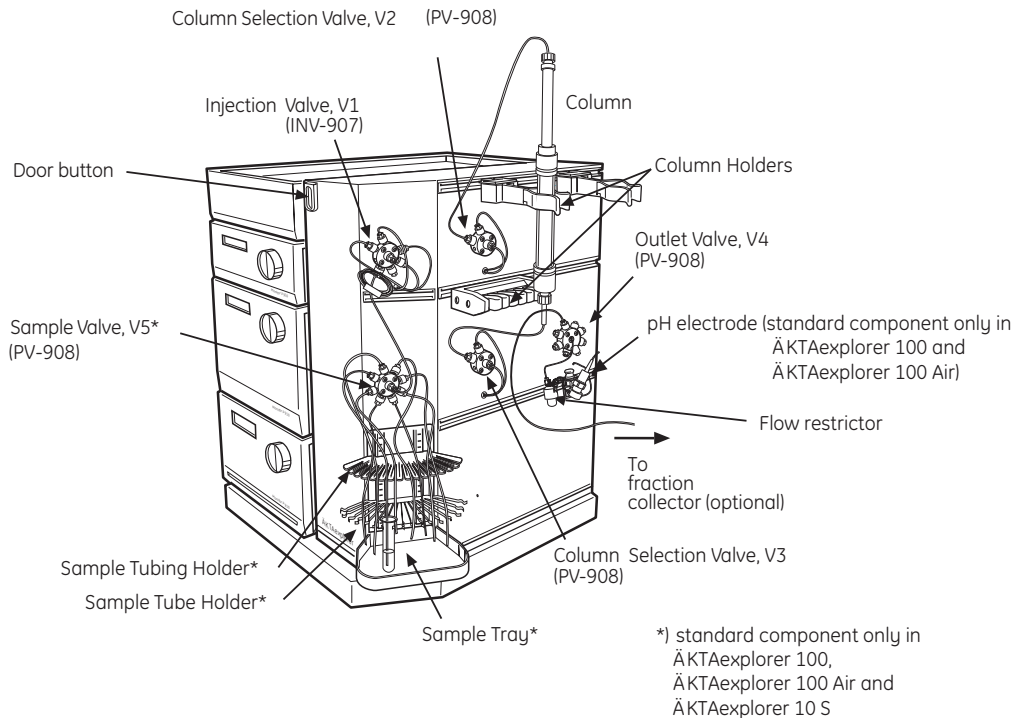

1 Introduction
 1.2 General

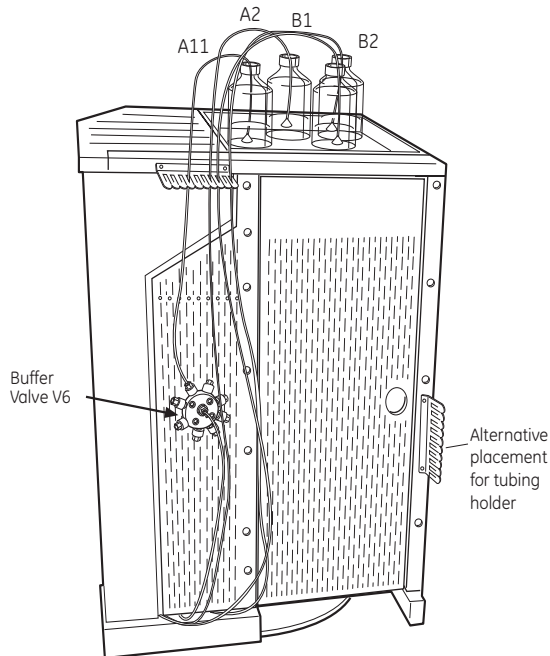
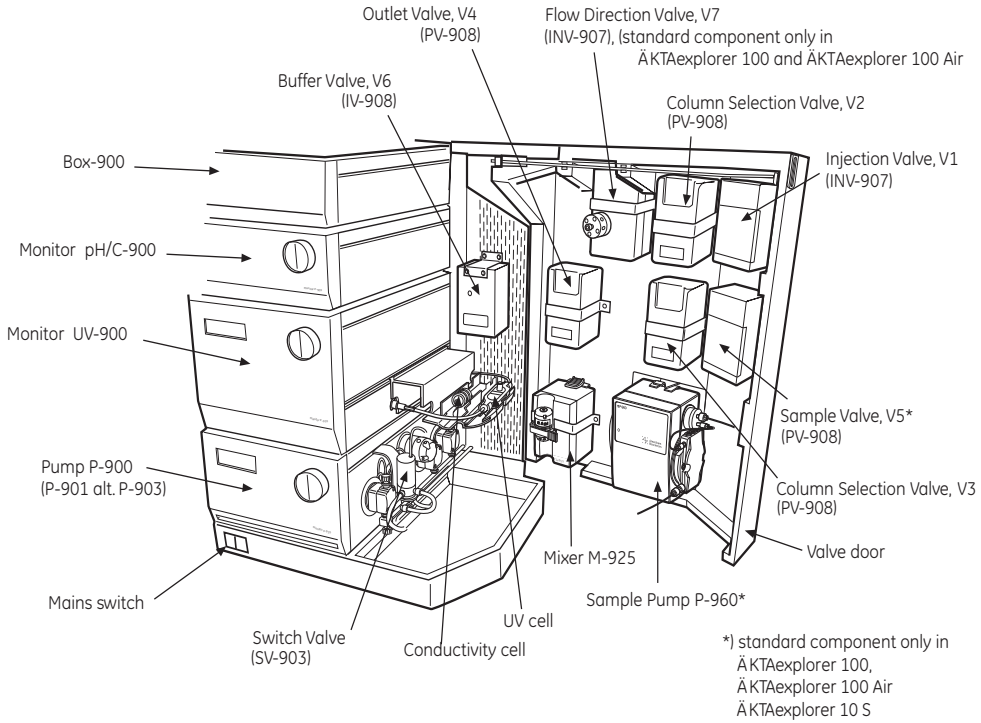

The figure below shows the purging parts for the Pump P-900.

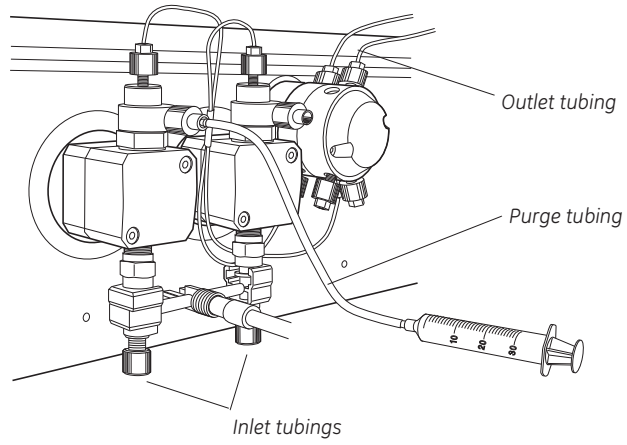

1.3 Safety

- The system is designed for indoor use only.
- Do not use in a dusty atmosphere or close to spraying water.

IMPORTANT! ÄKTAexplorer is intended for laboratory use only, not for clinical or in vitro use, or for diagnostic purposes.



WARNING! When using hazardous chemicals, all suitable protective measures, such as protective glasses and gloves resistant to the chemicals used. Follow local regulations and instructions for safe operation and maintenance of the system.



WARNING! The instruments must not be opened by the user. They contain high voltage circuits which can give a lethal electric shock.



WARNING! Monitor UV-900 uses high intensity ultra-violet light. Do not disconnect the optical fibres while the lamp is ON.



WARNING! In ÄKTAexplorer 100, never use i.d. 0.5 or 0.75 mm tubing with columns that can only withstand a low maximum pressure and that allow high flow rates, as the columns might rupture, resulting in injury.



WARNING! In ÄKTAexplorer 10, never use i.d. 0.25 mm tubing with columns that can only withstand a low maximum pressure and that allow high flow rates, as the columns might rupture, resulting in injury.



WARNING! The system must be connected to a grounded mains socket.



WARNING! There must always be a sample loop or Superloop connected to ports 2 and 6 of the injection valve. This is to prevent liquid spraying out of the ports when switching the valve. This is especially dangerous if hazardous chemicals are being used. If using a sample pump for sample application directly onto the column, a tubing must be connected between ports 3 and 6.



WARNING! Only spare parts that are approved or supplied by GE Healthcare may be used for maintaining or servicing the system.



WARNING! Always disconnect the power supply before attempting to replace any item on the system during maintenance.



WARNING! If the door is quickly pulled open to its full extent, the internal capillary tubing may be pulled from their connections causing leakage.



WARNING! Use ONLY tubings supplied by GE Healthcare to ensure that the pressure specifications of the tubings are fulfilled.



WARNING! When using hazardous chemicals, make sure that the entire system has been flushed thoroughly with distilled water before service and maintenance.



WARNING! For continued protection against risk of fire, replace only with a fuse of the specified type and rating. Refer to Technical Specifications for fuse data.



WARNING! If the system is turned or the fraction collector moved, the external capillaries and other tubing may become entangled in nearby objects and be pulled from their connections causing leakage.



WARNING! If heavier instrument components such as the pump are removed from the rack and the door is then opened fully, the shift in the centre of gravity of the system may cause it to tip over.

1 Introduction

1.3 Safety



WARNING! Never place buffer containers on the top of the valve door. If this is done, the containers might fall down when opening the valve door. Place the buffer containers on the buffer tray, above Box-900.



WARNING! Never block the ports on the outlet valve with stop plugs, since this will create over-pressure and may result in injury.



WARNING! Never place waste containers on the top of the system. If they become full and overflow, liquid may penetrate the system causing a short-circuit.



WARNING! The maximum allowed pressure for the tubing in the Tubing kit 1.0 is 3.4 MPa (34 bar, 493 psi). Set a pressure limit in UNICORN that is less than this value. If higher pressures are used, the tubing may break, releasing a jet of liquid.



WARNING! Incorrectly fitted tubing may loosen, causing a jet of liquid to spray out. This is especially dangerous if hazardous chemicals are in use. Connect the tubing by first inserting the tubing fully, then tightening the connector fingertight. PEEK tubing should be tightened a further 1/4 turn using the key supplied. Do not tighten Teflon tubing further as this damages the end of the tubing.

1.4 Optional configurations

The ÄKTAexplorer standard system configuration can easily be changed to optional configurations. This built-in flexibility in the standard ÄKTAexplorer system allows the user to enhance already used purification methods and also to develop new, more complex methods.

Optional configurations are selected, installed and implemented by the user. An optional configuration consists of both hardware components and software instructions.

To support the process of implementing optional configurations, general guidelines regarding installation and operation are given in the separate manual *ÄKTAexplorer Optional Configurations User Manual* included in the ÄKTAexplorer Manual Box.

Optional configurations are monitored and controlled via methods run by the UNICORN control system in the same way as the ÄKTAexplorer standard configuration.

Optional configurations supported by ÄKTAexplorer are:

- Connection of up to 9 motorized multi-port valves. These valves can be used to accomplish the following functions:
 - Buffer selection.
 - Sample selection¹
 - Optional functions.
- On-line pH measurement².
- Connection of a dedicated sample pump¹.
- Sample application using a SuperloopTM.
- Connection of a fraction collector.
- Connection of an autosampler.
- Connection of up to four air sensors³.
- Connection of external equipment using digital input/output signals through the system pump P-901/903 REMOTE connector.
- Connection of the AD-converter AD-900.

¹ Included in the standard configuration of ÄKTAexplorer 10 S, 100 and 100 Air.

² Included in the standard configuration of ÄKTAexplorer 100 and 100 Air.

³ Two sensors are included in the standard configuration of ÄKTAexplorer 100 Air.

- 1 Introduction
- 1.4 Optional configurations

2 Operation

This chapter describes how to optimize and operate ÄKTAexplorer for different applications. The options available are discussed in the following sections:

- Columns and tubing (Section 2.1)
- Sample application techniques (Sections 2.2–2.4)
- Gradient forming techniques (Section 2.5)
- BufferPrep (Section 2.6)
- Collecting fractions (Section 2.7)

The chapter also discusses how methods are selected and system handling while preparing a run (Section 2.8), during runs (Section 2.9), after runs (Section 2.10), cold room operation (Section 2.11), and feedback tuning (Section 2.12).

Please note that there are two flow restrictors available in the system:

- FR-904
Mounted at factory, and pre-adjusted to give a back-pressure of 0.4 MPa over the nominal flow range.
- FR-902
Supplied separately with the system, and pre-adjusted to give a back-pressure of 0.2 MPa over the nominal flow range. This flow restrictor is used when using the pH-electrode.

2.1 Columns and tubing

A wide range of pre-packed columns for ion exchange, size exclusion, hydrophobic interaction, reversed phase and affinity chromatography are suitable for use with ÄKTAexplorer. A comprehensive list of the recommended pre-packed columns is given overleaf together with information on the recommended tubing kit for each column.

It is very important to use the correct tubing kit taking into consideration the maximum allowed pressure for the column and the size of the column.

2.1.1 ÄKTAexplorer 10 tubing

On delivery, the system is equipped with i.d. 0.50 mm tubing (marked G, PEEK tubing, orange) from the pump to the injection valve and i.d. 0.25 mm tubing (marked G, PEEK tubing, blue) from the injection valve to the fraction collector (optional).

There is also a Tubing kit 0.50, to be used from the injection valve, available. It should be used with columns that have a low maximum pressure and allow high flow rates. If tubing with smaller inner diameter is used, the back-pressure will be too high and the columns may rupture.

Note: Use only maximum 80% acetonitrile eluent at pressures above 10 MPa. Otherwise, the lifetime of the tubing will deteriorate.



WARNING! Never use i.d. 0.25 mm tubing with columns that only can withstand a low maximum pressure and that allow high flow rates, as the column might rupture, resulting in injury.

2.1.2 ÄKTAexplorer 100 tubing

On delivery, the system is equipped with i.d. 0.75 mm tubing (marked G, PEEK tubing, green) from the pump to the fraction collector (optional). Tubing kit 0.5 (i.d. 0.5 mm, marked L, PEEK tubing, orange) and Tubing kit 1.0 (i.d. 1.0 mm, marked H, PEEK tubing, grey) are also available.



WARNING! Never use i.d. 0.5 or 0.75 mm tubing with columns that only can withstand a low pressure and that allow high flow rates, as the column might rupture, resulting in injury.

- To decrease peak band broadening and increase resolution, Tubing kit 0.5 should be used for columns giving peak volumes less than 1 ml.
- Tubing kit 1.0 should be used with columns that have a low maximum pressure and allow high flow rates. If tubing with smaller inner diameter is used, the back-pressure will be too high and the columns might rupture.

2.1.3 Recommended tubing and columns – ÄKTAexplorer 10

The tables below shows which tubing kit should be used for each column. It is important that the recommendations in these tables are followed. The tubing to be changed is described in Reference Information, Section 5.1.6.

Note: *In order to use low pressure columns, such as HiTrap and HiLoad, an extra system pressure measurement must be performed. This is described later in this section.*

X = recommended tubing kit

P = recommended for purity checks only

RF = can be used with indicated tubing if the optimal recommended flow rate in the column list is reduced in order not to exceed the column maximum pressure

2 Operation

2.1 Columns and tubing

Ion Exchange Columns

Code no	Column name	0.25	0.50
17-5177-01	Mini Q™ 4.6/50 PE	X, P	
17-5166-01	Mono Q™ 5/50 GL	X	
17-5167-01	Mono Q 10/100 GL	RF	X
17-0506-01	Mono Q HR 16/10	RF	X
17-5178-01	Mini S™ 4.6/50 PE	X, P	
17-5168-01	Mono S™ 5/50 GL	X	
17-5169-01	Mono S 10/100 GL	RF	X
17-0507-01	Mono S HR 16/10	RF	X
17-5181-01	SOURCE™ 15Q 4.6/100 PE	RF	X
17-5182-01	SOURCE 15S 4.6/100 PE	RF	X
17-1177-01	RESOURCE™ Q, 1 m		X
17-1179-01	RESOURCE Q, 6 ml		X
17-1178-01	RESOURCE S, 1 ml		X
17-1180-01	RESOURCE S, 6 ml		X
28-9165-37	HiTrap Capto™ DEAE, 1 ml		X
28-9165-40	HiTrap Capto DEAE, 5 ml		RF
17-5541-22	HiTrap Capto S, 1 ml		X
17-5441-23	HiTrap Capto S, 5 ml		RF
11-0013-02	HiTrap Capto Q, 1 ml		X
11-0013-03	HiTrap Capto Q, 5 ml		RF
28-4058-44	HiTrap Capto adhere, 1 ml		X
28-4058-46	HiTrap Capto adhere, 5ml		RF
11-0032-73	HiTrap Capto MMC, 1 ml		X
11-0032-75	HiTrap Capto MMC, 5 ml		RF
17-1153-01	HiTrap™ Q HP, 1 ml		X
17-1154-01	HiTrap Q HP, 5 ml		RF

Code no	Column name	0.25	0.50
17-1151-01	HiTrap SP HP, 1 ml		X
17-1152-01	HiTrap SP HP, 5 ml		RF
17-6002-33	HiTrap IEX Selection Kit (7 x 1 ml)		X
17-5053-01	HiTrap Q FF, 1 ml		X
17-5156-01	HiTrap Q FF, 5 ml		RF
17-5054-01	HiTrap SP FF, 1 ml		X
17-5157-01	HiTrap SP FF, 5 ml		RF
17-5055-01	HiTrap DEAE FF, 1 ml		X
17-5154-01	HiTrap DEAE FF, 5 ml		RF
17-5056-01	HiTrap CM FF, 1 ml		X
17-5155-01	HiTrap CM FF, 5 ml		RF
17-5162-01	HiTrap ANX FF (high sub), 1 ml		X
17-5163-01	HiTrap ANX FF (high sub), 5 ml		RF
17-5158-01	HiTrap Q XL, 1 ml		X
17-5159-01	HiTrap Q XL, 5 ml		RF
17-5160-01	HiTrap SP XL, 1 ml		X
17-5161-01	HiTrap SP XL, 5 ml		RF
17-5092-01	HiPrep 16/10 Q XL		RF
17-5093-01	HiPrep 16/10 SP XL		RF
17-5090-01	HiPrep 16/10 DEAE FF		RF
17-5091-01	HiPrep 16/10 CM FF		RF
17-5190-01	HiPrep 16/10 Q FF		RF
17-5192-01	HiPrep 16/10 SP FF		RF
17-5191-01	HiPrep 16/10 ANX FF (high sub)		RF
17-1064-01	HiLoad™ 16/10 Q Sepharose HP		X
17-1066-01	HiLoad 26/10 Q Sepharose HP		X
17-1137-01	HiLoad 16/10 SP Sepharose HP		X

2 Operation

2.1 Columns and tubing

Code no	Column name	0.25	0.50
17-1138-01	HiLoad 26/10 SP Sepharose HP		X

Size Exclusion Columns

Code no	Column name	0.25	0.50
17-1458-01	Superdex Peptide PC 3.2/30	X, P	
17-5176-01	Superdex Peptide 10/300 GL	X	
17-0771-01	Superdex 75 PC 3.2/30	X, P	
28-9205-04	Superdex 75 5/50 GL	X, P	
17-5174-01	Superdex 75 10/300 GL	X	
17-1089-01	Superdex 200 PC 3.2/30	X, P	
17-5175-01	Superdex 200 10/300 GL	X	
28-9065-61	Superdex 200 5/150 GL	X	
17-5172-01	Superose™ 6 10/300 GL	X	
17-0673-01	Superose 6 PC 3.2/30	X, P	
17-5173-01	Superose 12 10/300 GL	X	
17-0674-01	Superose 12 PC 3.2/30	X, P	
17-1408-01	HiTrap Desalting 5 ml		RF
17-5087-01	HiPrep 26/10 Desalting		RF
17-1139-01	HiLoad 16/60 Superdex 30 prep grade		X
17-1140-01	HiLoad 26/60 Superdex 30 prep grade		X
17-1068-01	HiLoad 16/60 Superdex 75 prep grade		X
17-1070-01	HiLoad 26/60 Superdex 75 prep grade		X
17-1069-01	HiLoad 16/60 Superdex 200 prep grade		X
17-1071-01	HiLoad 26/60 Superdex 200 prep grade		X
17-1165-01	HiPrep 16/60 Sephacryl S-100 HR		RF
17-1194-01	HiPrep 26/60 Sephacryl S-100 HR		RF
17-1166-01	HiPrep 16/60 Sephacryl S-200 HR		RF
17-1195-01	HiPrep 26/60 Sephacryl S-200 HR		RF
17-1167-01	HiPrep 16/60 Sephacryl S-300 HR		RF
17-1196-01	HiPrep 26/60 Sephacryl S-300 HR		RF

2 Operation

2.1 Columns and tubing

Hydrophobic Interaction Columns

Code no	Column name	0.25	0.50
17-5186-01	SOURCE 15PHE 4.6/100 PE		X
17-1184-01	RESOURCE ETH 1 ml		X
17-1185-01	RESOURCE ISO 1 ml		X
17-1186-01	RESOURCE PHE 1 ml		X
28-4110-07	HiTrap HIC Selection Kit (7 x 1 ml)		X
17-1355-01	HiTrap Phenyl FF (high sub), 1 ml		X
17-5193-01	HiTrap Phenyl FF (high sub), 5 ml		RF
17-1353-01	HiTrap Phenyl FF (low sub), 1 ml		X
17-5194-01	HiTrap Phenyl FF (low sub), 5 ml		RF
17-1351-01	HiTrap Phenyl HP, 1 ml		X
17-5195-01	HiTrap Phenyl HP, 5 ml		RF
17-1359-01	HiTrap Octyl FF, 1 ml		X
17-5196-01	HiTrap Octyl FF, 5 ml		RF
28-4110-01	HiTrap Butyl HP, 1 ml		X
28-4110-05	HiTrap Butyl HP, 5 ml		RF
17-1357-01	HiTrap Butyl FF, 1 ml		X
17-5197-01	HiTrap Butyl FF, 5 ml		RF
17-0978-13	HiTrap Butyl-S FF, 1 ml		X
17-0978-14	HiTrap Butyl-S FF, 5 ml		RF
17-1085-01	HiLoad 16/10 Phenyl Sepharose HP		X
17-1086-01	HiLoad 26/10 Phenyl Sepharose HP		X
17-5095-01	HiPrep 16/10 Phenyl FF (high sub)		RF
17-5094-01	HiPrep 16/10 Phenyl FF (low sub)		RF
17-5096-01	HiPrep 16/10 Butyl FF		RF
17-5097-01	HiPrep 16/10 Octyl FF		RF

Reversed Phase Columns

Code no	Column name	0.25	0.50
17-5116-01	SOURCE 5RPC ST 4.6/150	X	
17-5068-01	SOURCE 15RPC ST 4.6/100	X	
17-1181-01	RESOURCE RPC 1 ml	RF	X
17-1182-01	RESOURCE RPC 3 ml	RF	X
17-0704-01	μRPC C2/C18 SC 2.1/10	X, P	
17-5057-01	μRPC C2/C18 SC 4.6/100	X, P	

Affinity Columns

Code no	Column name	0.25	0.50
17-5247-01	HisTrap TM HP, 1 ml		X
17-5248-01	HisTrap HP, 5 ml		RF
17-5319-01	HisTrap FF, 1 ml		X
17-5255-01	HisTrap FF, 5 ml		RF
17-5256-01	HisPrep TM FF, 16/10		RF
11-0004-58	HisTrap FF crude, 1 ml		X
17-5286-01	HisTrap FF crude, 5 ml		RF
17-0920-03	HiTrap IMAC HP, 1 ml		X
17-0920-05	HiTrap IMAC HP, 5 ml		RF
17-0921-02	HiTrap IMAC FF, 1 ml		X
17-0921-04	HiTrap IMAC FF, 5 ml		RF
17-0921-06	HiPrep IMAC FF 16/10		RF
17-0408-01	HiTrap Chelating HP, 1 ml		X
17-0409-01	HiTrap Chelating HP, 5 ml		RF
17-0716-01	HiTrap NHS-activated HP, 1 ml		X
17-0717-01	HiTrap NHS-activated HP, 5 ml		RF
17-5281-01	GSTrap HP, 1 ml		X
17-5282-01	GSTrap HP, 5 ml		RF

2 Operation

2.1 Columns and tubing

Code no	Column name	0.25	0.50
17-5130-01	GSTrap™ FF, 1 ml		X
17-5131-01	GSTrap FF, 5 ml		RF
17-5234-01	GSTPrep™ FF 16/10		RF
28-4017-45	GSTrap 4B, 1 ml		X
28-4017-46	GSTrap 4B, 5 ml		RF
28-9187-78	MBPTrap™ HP, 1 ml		X
28-9187-79	MBPTrap HP, 5 ml		RF
28-9075-46	StrepTrap™ HP, 1 ml		X
28-9075-47	StrepTrap HP, 5 ml		RF
11-0034-93	HiTrap MabSelect SuRe™, 1 ml		X
11-0034-94	HiTrap MabSelect SuRe, 5 ml		RF
28-4082-58	HiTrap MabSelect Xtra™, 1 ml		X
28-4082-60	HiTrap MabSelect Xtra, 5 ml		RF
28-4082-53	HiTrap MabSelect™, 1 ml		X
28-4082-55	HiTrap MabSelect, 5 ml		RF
17-5079-01	HiTrap rProtein A FF, 1 ml		X
17-5080-01	HiTrap rProtein A FF, 5 ml		RF
17-0402-01	HiTrap Protein A HP, 1 ml		X
17-0403-01	HiTrap Protein A HP, 5 ml		RF
17-0404-01	HiTrap Protein G HP, 1 ml		X
17-0405-01	HiTrap Protein G HP, 5 ml		RF
17-0406-01	HiTrap Heparin HP, 1 ml		X
17-0407-03	HiTrap Heparin HP, 5 ml		RF
17-5189-01	HiPrep 16/10 Heparin FF		RF
17-0412-01	HiTrap Blue HP, 1 ml		X
17-0413-01	HiTrap Blue HP, 5 ml		RF
17-5110-01	HiTrap IgM Purification HP, 1 ml		X

Code no	Column name	0.25	0.50
17-5111-01	HiTrap IgY Purification HP, 5 ml		RF
17-5112-01	HiTrap Streptavidin HP, 1 ml		X
17-5143-01	HiTrap Benzamidine FF (high sub), 1 ml		X
17-5144-01	HiTrap Benzamidine FF (high sub), 5 ml		RF

Chromatofocusing Columns

Code no	Column name	0.25	0.50
17-5171-01	Mono P TM 5/200 GL	X	
17-5170-01	Mono P 5/50 GL	X	

2.1.4 Recommended tubing and columns – ÄKTAexplorer 100

The tables below shows which tubing kit should be used for each column. It is important that the recommendations in the table is followed. The tubing to be changed is described in *Reference Information*, Section 5.1.7.

Note: *When using low pressure columns, such as HiTrap and HiLoad, change to the Flow restrictor FR-902. If the pressure exceeds the pressure limit value given for these columns, an extra system pressure measurement must be performed. This is described later in this section.*

X = recommended tubing kit

(+) = may improve resolution

(x) = can be used if flow < 5 ml/min

(o) = should be used if flow > 30 ml/min

Ion Exchange Columns

Code no	Column name	0.50	0.75	1.0
17-5166-01	Mono Q TM 5/50 GL	(+)	X	
17-5167-01	Mono Q 10/100 GL		X	
17-5168-01	Mono S TM 5/50 GL	(+)	X	
17-5169-01	Mono S 10/100 GL	X		
17-1177-01	RESOURCE TM Q, 1 ml	(+)	X	
17-1179-01	RESOURCE Q, 6 ml		X	(o)

2 Operation

2.1 Columns and tubing

Code no	Column name	0.50	0.75	1.0
17-1178-01	RESOURCE S, 1 ml	(+)	X	
17-1180-01	RESOURCE S, 6 ml		X	(o)
11-0013-02	HiTrap Capto Q, 1 ml	(+)	X	
11-0013-03	HiTrap Capto Q, 5 ml		X	
11-0032-73	HiTrap Capto MMC, 1 ml	(+)	X	
11-0032-75	HiTrap Capto MMC, 5 ml		X	
17-1153-01	HiTrap TM Q HP, 1 ml	(+)	X	
17-1154-01	HiTrap Q HP, 5 ml		X	
28-9165-37	HiTrap Capto DEAE, 1ml	(+)	X	
28-9165-40	HiTrap Capto DEAE, 5ml		X	
17-5441-22	HiTrap Capto S, 1 ml	(+)	X	
17-5441-23	HiTrap Capto S, 5 ml		X	
17-1151-01	HiTrap SP HP, 1 ml	(+)	X	
17-1152-01	HiTrap SP HP, 5 ml		X	
28-4058-48	HiTrap Capto adhere, 1 ml	(+)	X	
28-4058-48	HiTrap Capto adhere, 5 ml		X	
17-6002-33	HiTrap IEX Selection Kit (7 x 1 ml)	(+)	X	
17-5053-01	HiTrap Q FF, 1 ml	(+)	X	
17-5156-01	HiTrap Q FF, 5 ml		X	
17-5054-01	HiTrap SP FF, 1 ml	(+)	X	
17-5157-01	HiTrap SP FF, 5 ml		X	
17-5055-01	HiTrap DEAE FF, 1 ml	(+)	X	
17-5154-01	HiTrap DEAE FF, 5 ml		X	
17-5056-01	HiTrap CM FF, 1 ml	(+)		X
17-5155-01	HiTrap CM FF, 5 ml		X	
17-5162-01	HiTrap ANX FF (high sub), 1 ml	(+)		X
17-5163-01	HiTrap ANX FF (high sub), 5 ml		X	

Code no	Column name	0.50	0.75	1.0
17-5158-01	HiTrap Q XL, 1 ml	(+)		X
17-5159-01	HiTrap Q XL, 5 ml		X	
17-5160-01	HiTrap SP XL, 1 ml	(+)		X
17-5161-01	HiTrap SP XL, 5 ml		X	
17-5092-01	HiPrep 16/10 Q XL		X	
17-5093-01	HiPrep 16/10 SP XL		X	
17-5090-01	HiPrep 16/10 DEAE FF		X	
17-5091-01	HiPrep 16/10 CM FF		X	
17-5190-01	HiPrep 16/10 Q FF		X	
17-5192-01	HiPrep 16/10 SP FF		X	
17-5191-01	HiPrep 16/10 ANX FF (high sub)		X	
17-5181-01	SOURCE™ 15Q 4.6/100 PE		X	
17-5182-01	SOURCE 15S 4.6/100 PE		X	
17-1064-01	HiLoad™ 16/10 Q Sepharose HP		X	
17-1066-01	HiLoad 26/10 Q Sepharose HP		X	
17-1137-01	HiLoad 16/10 SP Sepharose HP		X	
17-1138-01	HiLoad 26/10 SP Sepharose HP		X	

2 Operation

2.1 Columns and tubing

Size Exclusion Columns

Code no	Column name	0.50	0.75	1.0
17-5176-01	Superdex Peptide 10/300 GL	(+)	X	
17-5174-01	Superdex 75 10/300 GL	(+)	X	
17-5175-01	Superdex 200 10/300 GL	(+)	X	
17-5172-01	Superose 6 10/300 GL	(+)	X	
17-5173-01	Superose 12 10/300 GL	(+)	X	
17-1408-01	HiTrap Desalting 5 ml		X	
17-5087-01	HiPrep 26/10 Desalting		X	
17-1139-01	HiLoad 16/60 Superdex 30 prep grade		X	
17-1140-01	HiLoad 26/60 Superdex 30 prep grade		X	
17-1068-01	HiLoad 16/60 Superdex 75 prep grade		X	
17-1070-01	HiLoad 26/60 Superdex 75 prep grade		X	
17-1069-01	HiLoad 16/60 Superdex 200 prep grade		X	
17-1071-01	HiLoad 26/60 Superdex 200 prep grade		X	
17-1165-01	HiPrep 16/60 Sephacryl S-100 HR		X	
17-1194-01	HiPrep 26/60 Sephacryl S-100 HR		X	
17-1166-01	HiPrep 16/60 Sephacryl S-200 HR		X	
17-1195-01	HiPrep 26/60 Sephacryl S-200 HR		X	
17-1167-01	HiPrep 16/60 Sephacryl S-300 HR		X	
17-1196-01	HiPrep 26/60 Sephacryl S-300 HR		X	

Hydrophobic Interaction Columns

Code no	Column name	0.50	0.75	1.0
17-1184-01	RESOURCE ETH 1 ml		X	
17-1185-01	RESOURCE ISO 1 ml		X	
17-1186-01	RESOURCE PHE 1 ml		X	
17-1187-01	RESOURCE HIC Test Kit, 3 x 1 ml	(+)	X	
28-4110-07	HiTrap HIC Selection Kit, 7 x 1 ml	(+)		X
17-1355-01	HiTrap Phenyl FF (high sub), 1 ml	(+)		X
17-5193-01	HiTrap Phenyl FF (high sub), 5 ml		X	
17-1353-01	HiTrap Phenyl FF (low sub), 1 ml	(+)		X
17-5194-01	HiTrap Phenyl FF (low sub), 5 ml		X	
17-1351-01	HiTrap Phenyl HP, 1 ml	(+)		X
17-5195-01	HiTrap Phenyl HP, 5 ml		X	
17-1359-01	HiTrap Octyl FF, 1 ml	(+)		X
17-5196-01	HiTrap Octyl FF, 5 ml		X	
28-4110-01	HiTrap Butyl HP, 1 ml	(+)		X
28-4110-05	HiTrap Butyl HP, 5 ml		X	
17-1357-01	HiTrap Butyl FF, 1 ml	(+)		X
17-5197-01	HiTrap Butyl FF, 5 ml		X	
17-0978-13	HiTrap Butyl-S FF, 1 ml	(+)		X
17-1085-01	HiLoad 16/10 Phenyl Sepharose HP		(x)	X
17-1086-01	HiLoad 26/10 Phenyl Sepharose HP		(x)	X
17-5095-01	HiPrep 16/10 Phenyl FF (high sub)		X	
17-5094-01	HiPrep 16/10 Phenyl FF (low sub)		X	
17-5096-01	HiPrep 16/10 Butyl FF		X	
17-5097-01	HiPrep 16/10 Octyl FF		X	

2 Operation

2.1 Columns and tubing

Reversed Phase Columns

Code no	Column name	0.50	0.75	1.0
17-5116-01	SOURCE 5RPC ST 4.6/150	X		
17-5068-01	SOURCE 15RPC ST 4.6/100		X	
17-1181-01	RESOURCE RPC 1 ml	(+)	X	
17-1182-01	RESOURCE RPC 3 ml		X	
17-0704-01	μRPC C2/C18 SC 2.1/10	X, P		
17-5057-01	μRPC C2/C18 SC 4.6/100	X, P		

Affinity Columns

Code no	Column name	0.50	0.75	1.0
17-5247-01	HisTrap HP, 1 ml	(+)		X
17-5248-01	HisTrap HP, 5 ml		X	
17-5319-01	HisTrap FF, 1 ml	(+)		X
17-5255-01	HisTrap FF, 5 ml		X	
17-5256-01	HisPrep FF, 16/10		RF	
11-0004-58	HisTrap FF crude, 1 ml	(+)		X
17-5286-01	HisTrap FF crude, 5 ml		X	
17-0920-03	HiTrap IMAC HP, 1 ml	(+)		X
17-0920-05	HiTrap IMAC HP, 5 ml		X	
17-0921-02	HiTrap IMAC FF, 1 ml	(+)		X
17-0921-04	HiTrap IMAC FF, 5 ml	(+)		X
17-0921-06	HiPrep IMAC FF 16/10		RF	
17-0408-01	HiTrap Chelating HP, 1 ml	(+)		X
17-0409-01	HiTrap Chelating HP, 5 ml		X	
17-0716-01	HiTrap NHS-activated HP, 1 ml	(+)		X
17-0717-01	HiTrap NHS-activated HP, 5 ml		X	
17-5281-01	GSTrap HP, 1 ml	(+)		X
17-5282-01	GSTrap HP, 5 ml		X	

Code no	Column name	0.50	0.75	1.0
17-5130-01	GSTrap FF, 1 ml	(+)		X
17-5131-01	GSTrap FF, 5 ml		X	
17-5234-01	GSTPrep FF 16/10		RF	
28-4017-45	GSTrap 4B, 1 ml	(+)		X
28-4082-53	GSTrap 4B, 5 ml		X	
28-9187-78	MBPTrap HP, 1 ml	(+)		X
28-9187-79	MBPTrap HP, 5 ml		X	
28-9075-46	StrepTrap, 1 ml	(+)		X
28-9075-47	StrepTrap, 5 ml		X	
11-0034-93	HiTrap MabSelect SuRe, 1 ml	(+)		X
11-0034-94	HiTrap MabSelect SuRe, 5 ml		X	
28-4082-58	HiTrap MabSelect Xtra, 1 ml	(+)		X
28-4082-60	HiTrap MabSelect Xtra, 5 ml		X	
28-4082-53	HiTrap MabSelect, 1 ml			
28-4082-55	HiTrap MabSelect, 5 ml			
17-5079-01	HiTrap rProtein A FF, 1 ml	(+)		X
17-5080-01	HiTrap rProtein A FF, 5 ml		X	
17-0402-01	HiTrap Protein A HP, 1 ml	(+)		X
17-0403-01	HiTrap Protein A HP, 5 ml		X	
17-0404-01	HiTrap Protein G HP, 1 ml	(+)		X
17-0405-01	HiTrap Protein G HP, 5 ml		X	
17-0406-01	HiTrap Heparin HP, 1 ml	(+)		X
17-0407-01	HiTrap Heparin HP, 5 ml		X	
17-5189-01	HiPrep 16/10 Heparin FF		RF	
17-0412-01	HiTrap Blue HP, 1 ml	(+)		X
17-0413-01	HiTrap Blue HP, 5 ml		X	
17-5110-01	HiTrap IgM Purification HP, 1 ml	(+)		X

2 Operation

2.1 Columns and tubing

Code no	Column name	0.50	0.75	1.0
17-5111-01	HiTrap IgY Purification HP, 5 ml		RF	
17-5112-01	HiTrap Streptavidin HP, 1 ml		X	
17-5143-01	HiTrap Benzamidine FF (high sub), 1 ml		X	
17-5144-01	HiTrap Benzamidine FF (high sub), 5 ml		RF	

Chromatofocusing Columns

Code no	Column name	0.50	0.75	1.0
17-5171-01	Mono P 5/200 GL	(+)	X	
17-5170-01	Mono P 5/50 GL	(+)	X	

Selecting tubing kit for other columns – ÄKTAexplorer 100

For other columns, select the tubing kit as described below.

Note: Before starting to perform the described method below, make sure that the on-line filter does not generate too high a backpressure. Also, make sure that the column itself is clean and does not generate too high a backpressure.

- 1 Note the maximum specified back-pressure for the column at the variable Pressure limit on the Variables page in a method.

Note: The maximum allowed back-pressure on a self-packed column should never exceed 75% of the back-pressure used during the packing procedure.

- 2 Install the column and test to run at the flow rate and with the eluents to be used, with the i.d. 0.75 mm tubing kit.
 - a) If the generated back-pressure at the flow to be used is within the set column pressure limit, use the tubing kit already installed.
 - b) If the generated back-pressure at the flow rate to be used is well beyond the column pressure limit it is preferable to change to a narrower tubing kit, i.d. 0.5 mm. If the demands on low bandbroadening are less critical, use the tubing kit already installed.
 - c) If the generated back-pressure (after checking the on-line filter) at the flow rate to be used exceeds the set column pressure limit, change to a wider tubing kit, i.d. 1.0 mm. If the set column pressure limit is still exceeded with the i.d. 1.0 mm tubing kit installed, change to Flow restrictor FR-902, and check the generated backpressure according to the description below.

Note: The back-pressure might increase during e.g. sample injection and gradient formation due to viscosity variations. Make sure that these variations have been taken into consideration when selecting tubing kit.

2.1.5 Extra system pressure measurement

Sometimes an extra system pressure measurement must be performed, in order to use low pressure columns such as HiTrap and HiLoad. This is to compensate for the pre-column pressure so that the complete pressure range up to 0.5 MPa can be utilized across the column. Use Flow restrictor FR-902 for these columns.

It is necessary to account for the pre-column pressure by measuring the pressure in the absence of the column. This is achieved as follows:

- 1 Set the injection valve (INV-907) in position Waste.

2 Operation

2.2 Sample application overview

- 2 Run the pump at the mandatory or intended flow rate.
- 3 Make a note of the back-pressure on the pump display or in the Run Data pane in UNICORN.
- 4 Add this value to the pressure limit value for the column (e.g. 0.5 MPa for HiLoad or HiTrap).

The new total unit pressure value (measured pressure + max. column pressure) has to be introduced into the UNICORN column list and be defined as a personal column:

- 1 In the Method Editor, select Edit:Column list to open the Column List dialog window. Clicking a column in the list will display its parameters in the field to the right of the box.
- 2 Click Edit to display the Edit Column dialog. In the Parameter column, enter in the field for Max pressure the new unit pressure limit, 0.5 MPa + the measured value. Click Replace after the new value has been entered.
- 3 Click Save as and enter a new name of your column. You can choose to save the column globally, i.e. available to all users, by checking the Save as global box. However, we recommend to clear the Save as global box in this situation. Click OK.

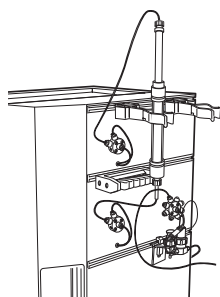

For further information, refer to *UNICORN User Manuals*.

If any of the above mentioned actions do not succeed, decrease the flow rate.

Connecting the column

The column is connected between the two column valves. Connect the columns to the valve positions set in the method, for example, between positions 2–2.

Position 1 is for bypass and no column should be connected to this position.

2.2 Sample application overview

With ÄKTAexplorer, the sample can be applied in a number of different ways to suit the application, sample volume and the degree of automation required.

The sample can be applied as follows:

- Using a sample loop, filled manually with a syringe or automatically with Pump P-960.
- Directly onto the column using Pump P-960 or the system pump.
- Using Superloop™, filled manually with a syringe, or filled automatically with Pump P-960.
- Using an autosampler, A-900 or A-905.

Autosampler A-900 and A-905 are available as optional components. They are described in the *ÅKTAexplorer Optional Configurations User Manual* and in their respective User Manual.

The sample injection technique is selected in the **Sample Injection** dialog in the Method Wizard. For a description of the injection methods and their contents, please refer to the method notes in UNICORN.

The following table shows which technique is recommended for different sample volumes.

Sample application technique	Volume to inject
Sample loop	
manual filling	0–2 ¹ ml
automated filling	0.1–2 ¹ ml
Directly onto the column using Pump P-960 ² or the system pump	> 1 ml
Superloop ³	1 ml–150 ml
Autosampler ⁴	1–500 µl

¹ For partial filling of the sample loop the recommended volume is up to 1 ml.

² How to apply the sample directly onto the column using the sample pump is described in the *ÅKTAexplorer Optional Configurations User Manual*.

³ How to use a Superloop is described in the *ÅKTAexplorer Optional Configurations User Manual*.

⁴ Depending on autosampler model and tubing selection. Refer to the *A-900 or A-905 User Manual*.

If the sample volume is to be varied automatically in a series of scouting runs, one of the following techniques can be used:

- Automated partial filling of the sample loop using Pump P-960 (0.1–2 ml).
- Applying the sample directly onto the column with the Pump P-960 (> 1 ml).
- Using a Superloop (1–150 ml).
- Using an Autosampler.

Section 2.3 describes manual filling of sample loops and Section 2.4 automated filling of sample loops. The other sample application techniques are described in the *ÅKTAexplorer Optional Configurations User Manual*.

2 Operation

2.3 Manual filling of sample loops

2.3 Manual filling of sample loops

Manual sample injection is selected in the **Sample Injection** dialog in UNICORN's Method Wizard.

2.3.1 Preparation

Prepare the injection valve as follows:

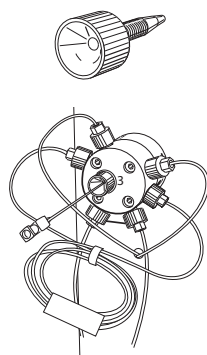

- 1 Loosely thread the supplied injection fill port screw into valve port 3.
- 2 Insert the supplied injection needle (o.d. 0.7 mm) into the injection fill port.
- 3 Tighten the fill port until the nozzle has formed a seal around the needle's tip, i.e. when it feels as if you are penetrating a septum at the end of the injection fill port. The seal should allow easy insertion and removal of the needle.
- 4 Mount the syringe holder on the fill port.
- 5 Make sure that waste tubing is connected to port 4 of the injection valve.
- 6 Mount the sample loop between ports 2 and 6 of the injection valve.

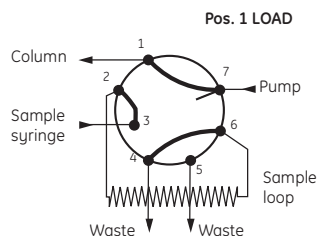

Note: If the syringe is removed before the sample is injected onto the column, self-drainage can occur and the loop will be emptied.

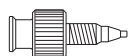

A Union Luer female/1/16" male connector is supplied with ÄKTAexplorer and is an alternative to the injection fill port. If used, the Union Luer connector replaces the injection fill port in port 3 of the injection valve.

Four sizes of sample loop are available:

Sample loop	Catalogue no.
Loop 100 µl, 25 MPa	18-1113-98
Loop 500 µl, 10 MPa	18-1113-99
Loop 1 ml, 10 MPa	18-1114-01
Loop 2 ml, 10 MPa	18-1114-02

When filling the loop with a sample volume equal to the loop volume, about 15% to 25% of the sample will be lost to waste because the fluid velocity in the sample loop tubing varies from a maximum at the tube axis to almost zero at the tubing wall. The exact amount of sample lost depends on the delivery flow rate.

Two techniques can be used for filling the sample loop; partial or complete filling.

Type of filling	Volume to load
Partial filling	Max. 50% of the sample loop volume
Complete filling	2–5 times the sample loop volume

2.3.2 Partial filling

Partial filling is used when high recovery is required. The sample volume loaded should be, at maximum, 50% of the loop volume. The volumetric accuracy and precision is that of the syringe. Partial filling allows the injected volume to be changed without changing the loop and does not waste sample. The sample loop must be completely filled with buffer before the sample can be loaded.

Partial filling is achieved as follows:

- 1 Set the injection valve to position INJECT.
- 2 Set the column valve to BYPASS.
- 3 Run the pump with buffer at low speed.
- 4 Load the syringe with the required volume of sample.

Note: *No more than half (50%) a loop volume of sample should be loaded into the loop.*

- 5 Insert the syringe into the injection fill port on the injection valve. Set the injection valve to position LOAD.

Note: *Do not load the sample before the valve is in position LOAD.*

- 6 Gently load the syringe contents into the sample loop.
- 7 Leave the syringe in position. The sample will be injected onto the column when the valve is switched to INJECT in the method.

2 Operation

2.3 Manual filling of sample loops

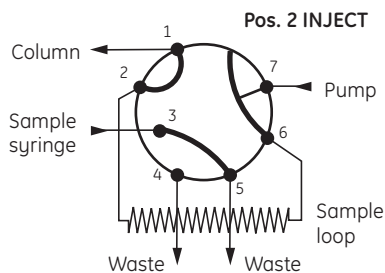

Note: If the syringe is taken out when the injection valve is in position **LOAD**, self drainage will occur and air will enter the sample loop.

2.3.3 Complete filling

With complete filling an excess of sample is used to ensure that the sample loop is filled completely. For analytical reproducibility, a sample volume 5 times the volume of the sample loop should be used. About 2 to 3 loop volumes of sample are required to achieve 95% of maximum loop volume. Five loop volumes ensure better precision.

With complete filling, the sample volume can only be changed by changing the loop size.

Complete filling is achieved as follows:

- 1 Set the injection valve to position **LOAD**.
- 2 Load the syringe with sample (2–5 times the loop volume).
- 3 Gently load the syringe contents into the loop.
- 4 Leave the syringe in position. The sample will be injected onto the column when the valve is switched to **INJECT** in the method.

Note: If the syringe is taken out before the sample is injected onto the column, self-drainage will occur and the loop will be emptied.

2.3.4 Emptying the sample loop

When emptying the sample loop, a buffer volume of at least 5 times the sample loop volume should be used to flush the loop and ensure that all sample is injected onto the column.

The volume for emptying the sample loop is set in the **Sample Injection** dialog in the Method Wizard.

2.4 Automated filling of sample loops using Pump P-960

Pump P-960 is a standard component in ÄKTAexplorer 10 S, 100 and 100 Air. It is also available as an accessory to other ÄKTAexplorer systems.

The sample loop can be filled automatically, which can be useful in, for example, scouting runs where samples must be applied repeatedly. Using sample loops supplied by GE Healthcare, volumes between 0.1–2.0 ml can be applied. The sample is drawn into the sample loop via tubing connected to the sample valve with the aid of a sample pump, Pump P-960.

Using the sample pump for filling the sample loop is selected in the Method Wizard.

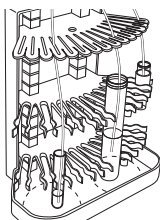

2.4.1 General preparation

Select appropriate instruction below (for using the same sample repeatedly or for using different samples) and prepare the system.

Prepare repeatedly sample application

- 1 Connect the sample pump inlet tubing to port 3 on the injection valve.
- 2 Make sure that the tubing from the central port of the sample valve is connected to port 4 on the injection valve.
- 3 Connect the sample loop between ports 2 and 6 on the injection valve.

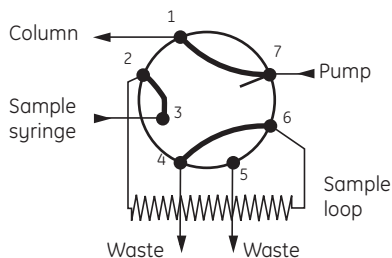

- 4 Make sure that the sample pump has been calibrated recently (see *Pump P-960 User Manual* for details).

Note: *Pump P-960 must be calibrated whenever the running conditions are changed, e.g. viscosity of sample or buffer, temperature, back-pressure etc. If the sample pump is not used frequently it should be calibrated before use.*

- 5 Place the inlet tubing from port 8 of the sample valve into a small bottle of starting buffer, buffer A. This solution should be used to rinse the tubing between the sample valve and the injection valve to increase precision.

2 Operation

2.4 Automated filling of sample loops using Pump P-960

- 6 Place the inlet tubings from the sample valve into test tubes containing the samples.
- 7 Set the injection valve to position LOAD, position 1.
- 8 Set the sample valve in the position corresponding to the first sample, position S1 (sample tube one).
- 9 Start the sample pump manually from UNICORN. To avoid cavitation, set the flow rate to max. 0.5 ml/min and let the pump run for approximately 40 seconds (= 0.35 ml) to completely fill the inlet tubing to the sample valve with sample.
- 10 Stop the sample pump.

Prepare application of different samples

- 1 Connect the sample pump inlet tubing to port 3 on the injection valve.
- 2 Make sure that the tubing from the central port of the sample valve is connected to port 4 on the injection valve.
- 3 Connect the sample loop between ports 2 and 6 on the injection valve.
- 4 Make sure that the sample pump has been calibrated recently (see *Pump P-960 User Manual* for details).

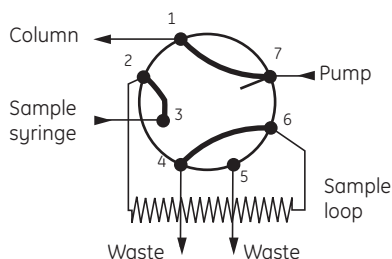

Note: Pump P-960 must be calibrated whenever the running conditions are changed, e.g. viscosity of sample or buffer, temperature, back-pressure etc. If the sample pump is not used frequently it should be calibrated before use.

- 5 Place the inlet tubing from port 8 of the sample valve into a small bottle of starting buffer, buffer A. This solution should be used to rinse the tubing between the sample valve and the injection valve to minimize carry-over when changing from one sample to another.
- 6 Place the inlet tubings from the sample valve into test tubes containing the samples.
- 7 Set the injection valve to position LOAD, position 1.

- 8 Set the sample valve in the position corresponding to the first sample, position S1 (sample tube one).
- 9 Start the sample pump manually from UNICORN. Set the flow rate to 0.5 ml/min and let the pump run for approximately 40 seconds (= 0.35 ml) to completely fill the inlet tubing to the sample valve with sample.
- 10 Stop the sample pump.
- 11 Set the sample valve in the position for the next sample.
- 12 Repeat step 9–11 until all inlet tubing to the sample valve have been filled with samples.
- 13 Set the sample valve manually from UNICORN in position S8. Start the sample pump from UNICORN. Set the flow rate to 0.5 ml/min and let the pump run for approximately 4 minutes (= 2 ml) to completely fill the tubing from the test tube with starting buffer to the injection valve with starting buffer.
- 14 Stop the sample pump.
- 15 Set the injection valve to position INJECT, pos. 2.
- 16 Flush the sample loop by starting Pump P-960. Let a volume of 5 times the volume of the sample loop pass through.
- 17 Stop Pump P-960 and set the injection valve to LOAD, pos.1, by clicking **End**. The system is now ready to start a run.

2.4.2 Filling the loop

Prepare the system as described above and proceed as described below.

- 1 Select **Sample Pump Loop Filling P-960** in the **Sample Injection** dialog in the Method Wizard.
- 2 Enter the sample volume in the variable **Fill_Loop_with**. To compensate for the volume between the sample valve and the injection valve, 85 µl should be added to the sample volume entered in the variable in UNICORN. For complete filling an overflow of 2–5 times the loop volume is needed for maximal reproducibility between the runs.

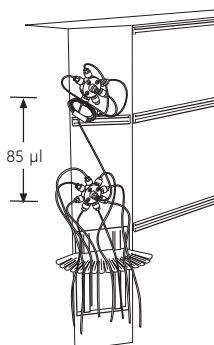

Note: When only one sample is used, it is only necessary to compensate for the volume between the sample valve and the injection valve the first time the sample is applied.

- 3 Enter 5 times the volume of the sample loop for the variable **Sample_Inlet_S8-Rinse_Sample_Flowpath_with**. This will rinse the tubing between the sample valve and the injection valve as well as the sample loop before the sample is loaded into the sample loop.

2 Operation

2.5 Mixing gradients

Note: When the same sample is used for repeatedly application, the tubing between the sample valve and the injection valve as well as the sample loop does not need to be rinsed with buffer between runs. Enter zero for the variable **Sample_Inlet_S8-Rinse_Sample_Flowpath_with**.

- 4 Selection of the different samples is specified in the Sample_Inlet variable. The samples will be applied automatically. In scouting runs you can enter different sample volumes with the variable **Fill_Loop_with**.

2.4.3 Emptying the sample loop

When emptying the sample loop, a buffer volume of approximately 5 times the sample loop volume should be used to flush the loop to make sure that all sample is injected onto the column.

The volume for emptying the sample loop is set in the variable **Empty_Loop_with** in the **Sample Injection** dialog in the Method Wizard.

2.5 Mixing gradients

2.5.1 Gradients

There are two different techniques available for mixing gradients. The standard technique using two separate buffers, one to each pump module, and the BufferPrep technique using four solutions, two to each pump module, generating the buffer on-line with a switch valve before each pump module. The minimum flow rate for BufferPrep is 1.0 ml/min. The outputs of the pump modules are routed to a mixer. The BufferPrep method is described in Section 2.6 BufferPrep.

2.5.2 Mixer



WARNING! When using hazardous chemicals, flush the mixer chamber thoroughly with distilled water before removing it.

ÄKTAexplorer 10

The mixer is delivered with two different mixer chambers, 0.6 and 2 ml. At delivery the 0.6 ml mixer chamber is installed and can be used at gradient volumes up to 5 ml (binary gradients).

ÄKTAexplorer 100

The mixer is delivered with a 2 ml chamber installed. Two separate chambers, 5 and 12 ml, are also supplied.

The recommended minimum gradient volume for each mixing chamber is specified in the table below.

Mixing chamber volume	Recommended minimum gradient volume	
	Binary gradient	BufferPrep gradient
0.6 ml	5 ml	-
2 ml	16 ml	60 ml
5 ml	38 ml	80 ml
12 ml	90 ml	113 ml

When using eluents that are more difficult to mix such as isopropanol and water, a larger mixer volume can be used to get optimum mixing.

Note: *If the pH and conductivity curves indicate uneven mixing of your buffers (unstable curves), use a larger mixer chamber. If this does not work, refer to the Troubleshooting chapter, Sections 4.4 and 4.5.*

Note: *Always place the buffer bottles lower than the mixer when changing chambers, to prevent draining.*

2.6 BufferPrep

2.6.1 What is BufferPrep?

BufferPrep eliminates the time-consuming manual buffer preparation and titration usually needed for every pH change in chromatography. For any pH and salt concentration entered, BufferPrep automatically calculates and prepares the composition of the buffer on-line, from four stock solutions. Linear and step salt gradients can be run and pH can be used as a variable scouting parameter.

Note: *To get optimum result, it is recommended to calibrate the pH electrode once a day.*

BufferPrep is optimized for use in ion exchange chromatography method development, but can also be used for size exclusion chromatography and affinity chromatography.

The four stock solutions consist of:

- 1 A mix of buffering components. Up to five different buffering components with up to three pK_as each enabling a broad pH range to be covered.
- 2 An acid (HCl) or base (NaOH) for on-line titration of pH.

2 Operation

2.6 BufferPrep

- 3 Distilled water.
- 4 An inert salt (e.g. NaCl or KCl) for elution gradient formation.

BufferPrep compensates for the pKa drift with changed ionic strength and temperature. A number of pre-defined recipes are available. New recipes can also be created, see *Reference Information*, Section 5.3.

The pH is generated from pump module A and the salt concentration from pump module B. The stock solutions containing the buffering component mix and the HCl or NaOH are connected to pump module A. The stock solutions containing salt and water are connected to pump module B. A switch valve on each pump module, together with the BufferPrep algorithms, generates the correct mixing ratios for the set pH. Each pump module delivers 50% of the set flow.

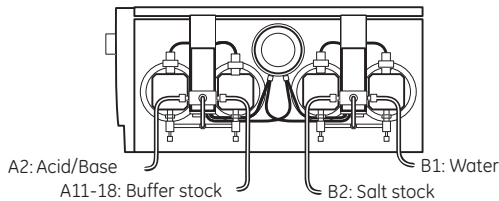

Pump module A

To achieve a set pH, the buffering stock solution and the acid/base stock solution are mixed via the switch valve in a ratio that depends on the buffering substance characteristics at the set pH. An example of the mixing ratios between the two stock solutions is shown below.

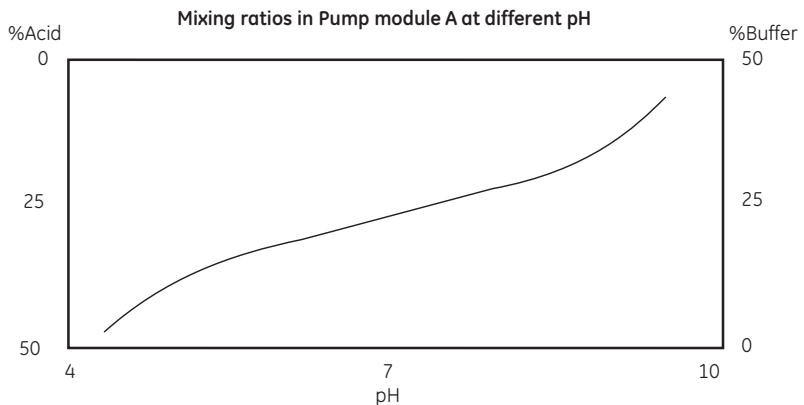

Note that the shape of the mixing ratio curve will differ for different buffering substances.

Pump module B

To achieve the set eluent, the eluent stock solution and water are mixed via the switch valve in a ratio that depends on the programmed eluent concentration variation during elution.

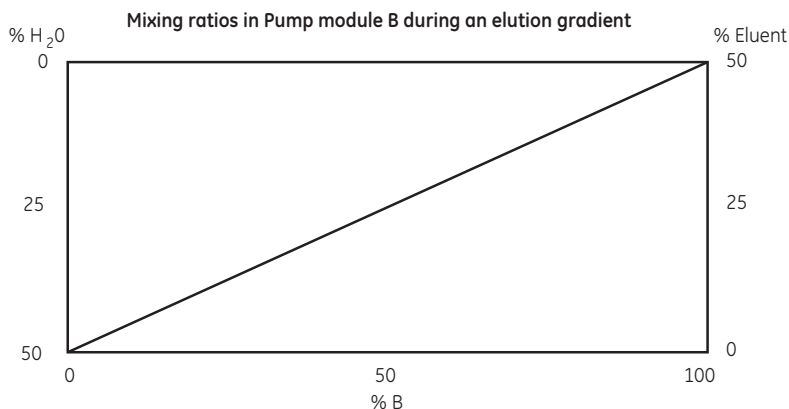

2.6.2 Strategy for using BufferPrep

BufferPrep should be used to quickly find the optimal pH for your protein purification procedure. Use it as follows:

- 1 Start with a recipe covering a broad pH range and scout for pH in steps of, for example, 0.5–1 pH units.
- 2 Select the pH that gives the best result.
- 3 Either continue with the broad pH range recipe or change to a single buffer recipe within the pH range that gave the best result.

2.6.3 Creating a method for pH scouting

- 1 Do one of the following:
 - a) Create a new method with the Method Wizard selecting **BufferPrep**, or
 - b) Insert the **BufferPrep_pH** instruction at the top of an existing method. Open the **BufferPrep** page in Run setup of the Method Editor and select the **BufferPrep ON** button.
- 2 Select the recipe that corresponds to the technique and pH range required (available as selections in the wizard). The broad pH range recipes are:
 - CIEX: (for cation exchange chromatography) pH 3 to 7.5.
 - ALEX: (for anion exchange chromatography) pH 5 to 9.5.

- ALEX: (for anion exchange chromatography) pH 6 to 9.0.

A number of single buffer recipes, each covering narrower pH ranges, are also available (see Section 5.3.6).

- 3 Prepare the required solutions. Details about preparation can be found in the **Note** field in the **BufferPrep** page. The required solutions and the inlets to which they should be connected, are displayed to the right in the **BufferPrep** page. Accuracy of preparation is essential. Use ampoules of exact concentrations for HCl and NaOH if available. If not available, the correction factors may need to be adjusted each time a new stock solution is prepared.

Inlet A11–A18: Buffer mix

Inlet A2: HCl or NaOH

Inlet B1: H₂O

Inlet B2: Eluent

- 4 Open the **Scouting** page. Select **BufferPrep_pH** from the list displayed and click **OK**. Enter the required pH for each run.

Note: *To keep the equilibration volumes to a minimum between runs during pH scouting, start with the lowest pH and increase the pH for each run when titrating with an acid (as in the ALEX and CIEX recipes). When titrating with a base start with the highest pH.*

- 5 Click the **Variables** page.

To obtain a stable pH, make sure that the equilibration volume is at least:

In ÄKTAexplorer 10: 9 ml with 0.6 ml mixer, or 14 ml with 2 ml mixer.

In ÄKTAexplorer 100: 30 ml with 2 ml mixer, 50 ml with 5 ml mixer, or 100 ml with 12 ml mixer.

Up to 20 column volumes of equilibration may be required to obtain a stable pH.

- 6 Save the method.

2.6.4 Preparing the system for a BufferPrep run

- 1 Calibrate the pH monitor. Refer to Monitor pH/C-900 User Manual. For high accuracy measurements, calibration should be performed with the pH electrode fitted in the flow cell at the flow rate to be used in the scouting run.

- 2 Manually fill the inlet tubing with the stock solution by using the **PumpWashExplorer** instruction in UNICORN.
- 3 If equilibration is not programmed into the method, equilibrate the system manually without a column with the set pH before starting the run. In **System Control** select **Manual:Other** and click **BufferPrep_Recipe**. Select the same recipe as you have in your method. Click **Execute**.
- 4 To switch to the **Pump Instructions**, select **Pump**. Select **BufferPrep_pH** and enter the same pH as set in the method. Click **Execute**.
- 5 Select **Flow** and set a flow rate. Click **Execute**.
Use the following equilibration volumes (at minimum) to obtain a steady pH reading:
In ÄKTAexplorer 10: 9 ml with 0.6 ml mixer, or 14 ml with 2 ml mixer.
In ÄKTAexplorer 100: 30 ml with 2 ml mixer, 50 ml with 5 ml mixer, or 100 ml with 12 ml mixer.
- 6 When running pH scouting, the sample should, if possible, have a pH close to the highest pH in the scouting run for AIEX and close to the lowest pH for CIEX. The conductivity of the sample should be below 5 mS/cm.
- 7 Start the run.

2.6.5 Fine tuning

To obtain higher pH accuracy, the recipe can be fine tuned around a specific pH. When scouting over a broad pH range fine tuning is less beneficial. Run BufferPrep manually at 0 and 100% B as follows:

- 1 In the **System Control** module select **Manual:Other**. Select **BufferPrep Recipe** and select recipe in the **Recipe Names** list.
- 2 To switch to the **Pump Instructions**, select **Pump**. Select **BufferPrep_pH** and enter the pH value. Select **Flow** and set a flow rate.
- 3 Start a run manually at 0% B. Make sure the buffer valve is set correctly to the required inlet (A11–A18).
- 4 Check the pH reading when stable.
- 5 Change to 100% B by setting the **Gradient** instruction in **Manual:Pump** to 100% B for **Target** and 0 for **Length**. Click **Execute**.
- 6 Check the pH reading when stable at 100% B.
- 7 If the reading is acceptable at both 0 and 100% B, the run can be started.
- 8 If the pH reading is not acceptable it is possible to correct the factors for the recipe. Select **Edit:BufferPrep Recipes** in the Method Editor. Click **New**. In the

2 Operation

2.7 Collecting fractions

New Recipe dialog click **Correction factors**. Enter the pH deviation at 0 and 100% B. (For example, if the pH set is 7.0 and the actual pH is 7.1 enter 0.1, or if the actual pH is 6.9, enter -0.1).

9 Save the method.

Note: *The new correction factors will only apply while this method is used. When a new method is created and a recipe is selected, default correction factors will apply. To change default correction factors for a recipe see Section 5.3.4.*

2.6.6 Creating your own recipes

Refer to Section 5.3.1 for details on how to create recipes or edit existing recipes.

2.7 Collecting fractions

Fractions can be collected with a fraction collector (optional). The software makes it possible to fractionate in different ways:

- Flowthrough fractionation.
- Fixed volume fractionation and/or peak fractionation.

Fractionation is selected and specified in the fractionation dialogs in the Method Wizard. Fraction collection is described in detail in *ÅKTAexplorer Optional Configurations User Manual*.

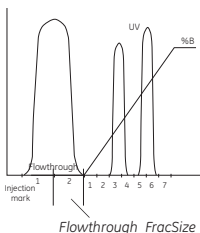

2.7.1 Flowthrough fractionation

Flowthrough fractionation means that fixed volumes are collected before elution fractionation starts. This fractionation method is available in all methods, except gel filtration methods. The fractionation volume is set in the **Flowthrough_Fractionation** dialog in the Method Wizard.

2.7.2 Fixed volume and/or peak fractionation

Fixed volume fractionation allows you to collect fixed volumes during elution. The Fraction Volume is set in the Elution_Fractionation dialog in the Method Wizard. You will choose elution technique and set interval for the fractionation, for example, interval of %B or Cond, in the Elution dialog.

Fixed volume fractionation can be combined with peak fractionation, which means collecting peaks during elution. There are two ways to collect peaks:

- Peaks are collected in one fraction each. The peak size is set to a volume which is larger than the actual peak volumes.
- Peaks are collected in several fractions. The peak size is set to a volume which is smaller than the actual peak volume.

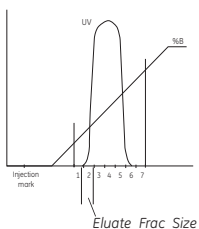

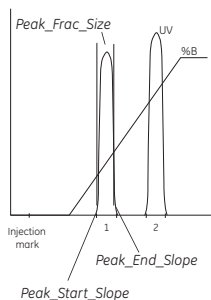

The properties for the peak slopes and levels are set in the **Peak_Fractionation** dialog in the Method Wizard. That include variables:

- for control of the start and end points of the peak fractions to be collected,
- for control of the minimum peak width to be collected, and/or
- that set the peak volume sizes during the fractionation slope/level interval.

Refer to *UNICORN User manuals* for further description of the peak slopes and levels properties.

2.7.3 Outlet valve

An outlet valve is included for directing the liquid flow to either waste or to fractionation. To perform outlet fractionation, select **Outlet Valve** in the **Elution Fractionation** dialog in the Method Wizard.

- Port 1 (valve default position) should always be connected to a waste flask of suitable size (W3).
- A fraction collector can be connected to the outlet valve with tubing G11/H11 in ÄKTAexplorer 10 and with tubing G15/H15/L6 in ÄKTAexplorer 100. If using the Method Wizard to create a method, and using the fraction collector Frac-920, the port 2 of the outlet valve will be selected by default.
- The outlet valve can also be used for fractionation of larger fractions.

2.8 Before a run

2.8.1 Selecting a method

Use the Method Wizard in UNICORN for creating methods.

The basic steps required to create a method are:

- 1 In the **Method Editor**, select **File:Method Wizard**. Select system if required.
- 2 Select the appropriate parameter values in the subsequent pages. Click **Next** to go to the next page.
- 3 Click **Finish** in the last page.
- 4 Check and fine-tune the values for the method variables, e.g. for the flow, in the **Variables** page.
- 5 Save the method.

Note: Before starting the run, check that the system is in End mode, and that the valves are in their initial positions.

2.8.2 Calibrations

The table below lists the type and frequency of calibrations that can be done on ÄKTAexplorer. Refer to *UNICORN User Manual* and to the individual component User Manuals and Instructions for descriptions of how to perform these calibrations. The calibrations are performed from UNICORN by selecting **System:Calibrate** in **System Control**.

Component	How often
pH monitor	Every day.
Pump P-960 (if applicable)	Whenever the running conditions are changed, e.g. viscosity of sample or buffer, temperature, backpressure etc. If the sample pump is not used frequently it should be calibrated before use.
Pressure reading	Once a year or when required.
Conductivity flow cell Cell constant	Only necessary if specific conductivity with high accuracy is measured (Cond_Calib).
Temperature	Must be done when changing the conductivity flow cell (Temp).
Entering a new cell constant	Must be done when changing the conductivity flow cell (Cond_Cell).

Using the pH electrode

When using the pH electrode (if applicable), the flow restrictor FR-904, which is mounted from factory, must be replaced with the supplied flow restrictor FR-902. (The flow restrictor is placed after the pH electrode.) Otherwise, the long term stability and lifetime of the pH electrode will deteriorate.

2.8.3 General preparation

Before starting any method, we recommend you make certain checks to ensure that problems are not encountered once the run has been started.

- 1 Check that the inlet tubings are immersed in the correct bottles for the method selected.
- 2 Check that there is sufficient eluent available.
- 3 Check that the waste bottle is not full and will accept the volume diverted to it during the run.
- 4 Check that the pump has been purged (i.e. no air in the inlet tubing). If not, purge the pump as described in the *P-900 User Manual*.

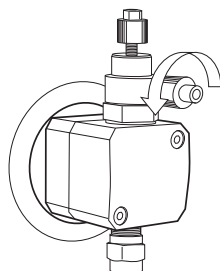

- 5 Calibrate the pH electrode¹ if required. Refer to *Monitor pH/C-900 User Manual*. Remember to change the flow restrictor FR-904 to flow restrictor FR-902 when the pH electrode is mounted in the pH flow cell.
- 6 Calibrate the sample pump P-960² if it has not been used recently or if the running conditions have changed, e.g. sample viscosity, back pressure etc.
- 7 Check that the correct column has been fitted and equilibrated (if not included in the method).
- 8 Check that the correct mixer chamber and tubing are installed for the method selected.
- 9 Use the **SystemWash** instruction to wash the system in bypass mode with the start buffer.

2.9 During a run

2.9.1 Viewing progress

The progress of the method being used can be viewed in detail on UNICORN and the status of certain parameters of the modules can be viewed directly on their front panel displays.

The **System Control** window in UNICORN displays the current status of ÄKTAexplorer and can display up to four panes for monitoring different aspects of the run. Click on the **Customize panes** toolbar button or choose **View:Panels** from the menu to select which panes to display.

Run Data

The run data pane displays the current values for selected run parameters. Right-click in the **Run Data** pane and select **Properties**. Select the run data items to be displayed and click **OK**.

Curves

The curves pane displays the monitor signal values graphically. Right click in the **Curves** pane and select **Properties** to select the curves to display. All curves are always stored in the result file.

Flow scheme

The flow scheme is a graphical representation of the flow path in the chromatography system. During a run, the flow scheme shows open flow paths and monitor signals with numerical displays.

¹ Optional component in ÄKTAexplorer 10 and 10 S.

² Optional component in ÄKTAexplorer 10.

2 Operation

2.9 During a run

Logbook

All actions and unexpected conditions such as warnings are logged for every run, with date, time and current user name. The logbook provides a complete history of any given run. The log is saved in the result file.

Front panel displays

The front panel displays of Monitor UV-900, Monitor pH/C-900 and Pump P-900 can be set to show their current status. In each case, the main operating menu display shows the most important parameters.

Run	13.40ml/min
2.00MPa	45.5%B

The main operating menu of Pump P-900 shows the current flow rate together with a mode indication, pressure and %B, if used. The available modes are:

- Run** The pump is running with the set flow rate.
- End** The system is not running.
- Pause** The pump is stopped but the set flow rate and the gradient values are retained.
- Hold** The gradient is held at the value displayed and the pump continues to run.

λ 1 [215]	1.123 AU
λ 1 [254]	0.02345 AU

λ 1 [280]	0.1234 AU
-------------------	-----------

The main operating menu of the Monitor UV-900 shows the absorbance values with 4 digits for up to 3 active wavelengths. The display for the third wavelength is reached by turning the dial clockwise. It is also possible to view all three wavelengths simultaneously by turning the dial one step further (only three digits).

Cond	Temp	pH
25.4%	22.9°C	11.5

The main operating menu of the pH/C-900 Monitor shows the conductivity as a percentage of full scale together with the current temperature in the flow cell, and the pH value.

4.000mS/cm	22.9°C
---	25.4%

By turning the dial one click, an alternative display of the conductivity is shown. This display shows the temperature, and the actual conductivity value in mS/cm or μ S/cm together with the percentage value and as a horizontal bar graph.

└─ Bar graph

2.9.2 Changing parameters

From UNICORN

ÅKTAexplorer can be controlled with manual instructions issued from the **Manual** menu in **System Control** in UNICORN. These instructions can be used during a run to alter system conditions in response to the results observed.

The **Manual** menu in **System Control** opens a dialog box similar to the text instruction box in the **Method Editor**. Manual instructions are entered as follows:

- 1 Highlight the instructions list by clicking on a button on the left of the instruction panel and select the required instruction(s) from the list displayed.
- 2 Fill in the parameters and click Execute.

Some instructions, for example, gradient or fraction instructions, may take time to complete. To print all instructions with explanations, click on **Print** in the **Method Editor:File** menu. This opens a window containing instructions that are printable. Make sure that the **Instruction Set** box is checked and clear any unwanted items. Click **Print** to print the instructions.

From the modules

Manual changes can also be performed on the pump, UV and pH/Cond monitors using the selection dial.

Manual changes in UNICORN or on the modules are equivalent. Manual changes are normally recorded in the log book. The selection dial on the modules can be set in one of three different access modes:

- **Open** – the dial on the module can be used for manual changes.
- **KeyLocked** – the dial on the module can be used to select different menus, but cannot be used to change any parameters.
- **KeyAndDialLocked** – Neither menu selection nor parameter changes can be performed.

To select access mode, select **System:Settings** in **System Control** then **Specials:Keyboard**. Select **Open**, **KeyLocked** or **KeyAndDialLocked**.

2.10 Completion of a run and storage

All valves return to default positions (i.e. position 1) after a run.

2.10.1 Storage

Overnight

Let the system run isocratically at a low flow rate (approximately 10% of the used flow rate)

2 Operation

2.11 Cold room operation

Weekend and long term storage

Flush the system with water and then fill it with 20% ethanol (not the pH electrode, see separate instructions below).

CAUTION! Never leave the pH electrode in the flow cell for any period of time when the system is not used, since this might cause the glass membrane of the electrode to dry out. Dismount the pH electrode from the flow cell and fit the end cover filled with a 1:1 mixture of pH 4 buffer and 2 M KNO₃. Do NOT store in water only.

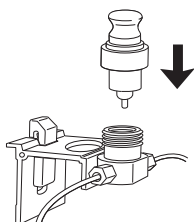

pH electrode

The pH electrode¹ should always be stored in a 1:1 mixture of pH 4 buffer and 2 M KNO₃ when not in use. When the pH electrode is removed from the flow cell, the dummy electrode (supplied) shall be inserted in the flow path. Remember to change from the flow restrictor FR-902 to flow restrictor FR-904 when the pH electrode is no longer to be used in the flowpath.

2.11 Cold room operation

Cold room operation is sometimes necessary to keep the biomolecule(s) of interest stable.

2.11.1 Preparation

- 1 Place the separation unit in the cold room.
- 2 Place the computer outside the cold room. A 15 m UniNet cable is available as an accessory and should be used to connect the computer to the separation unit.
- 3 Allow the separation unit to stabilize at the new temperature for at least 12 hours.
- 4 Tighten all connections and pump water through the system to check for leaks.
- 5 Tighten any leaking connector.

2.11.2 Running

Before starting a run, check the following:

- 1 Make sure that the temperature of the buffers has reached the ambient temperature.

¹ Optional component in ÄKTAexplorer 10 and 10 S.

- 2 Calibrate the pH electrode.
- 3 Check the pH of the buffers.

Note: *The measured temperature of the system is the temperature in the conductivity flow cell, which can differ from the ambient temperature.*

2.11.3 Removal from cold room

- 1 Loosen all connections to prevent them sticking when the system returns to room temperature.
- 2 Allow the separation unit to stabilize at room temperature for at least 12 hours.
- 3 Tighten all connections and pump water through the system to check for leaks.
- 4 Tighten any leaking connector.

2.12 Feedback tuning

Feedback tuning of the sample pump and the system pump is used for:

- Maintaining the requested pump flow rate.
- Making sure that the maximum pressure limit is not exceeded.

Feedback tuning is useful in applications where high back-pressure can be expected, or when the back-pressure fluctuates, for example, when using samples with high viscosity.

The feedback tuning is set in the Method Wizard and it is activated only during sample application and wash-out of unbound sample.

Feedback tuning is set up and used in slightly different ways when applied to the system pump and the sample pump, which is described in the following sections.

2.12.1 Feedback tuning of the system pump

Tuning principle

There are two regulators involved in tuning the system pump. The first one is active as long as the pressure is below the set point. This regulator tunes the actual pump flow rate to the set flow rate. If the pressure exceeds the set point, a second regulator decreases the flow rate in order to reduce the pressure. When the pressure falls below the set point, the first regulator takes control again and tunes the actual flow rate to the set flow rate, and so on.

The regulators use so-called PID feedback tuning, where P, I and D are parameters that determine the tuning characteristics. The default PID values in UNICORN provide a robust feedback tuning that suits most purposes. However, the parameters can be further optimized to suit a specific application (see section Optimizing the PID parameters).

Feedback tuning of the system pump in a method

- 1 To include feedback tuning in the Method Wizard, select Flow Regulation of the System Pump.
- 2 Type the pressure control set point (slightly below the column pressure limit) and the minimum allowed flow.

The PID parameter values can later be changed separately in System:Settings in the System Control module.

Note: *If the flow rate falls below the MinFlow value, an Alarm is raised and the system will be set to Pause. Therefore, we recommend using a Watch instruction (WatchPar_Flow) for the flow that is activated above this value. A suitable action is to continue to the next block.*

To prevent pressure peaks when continuing, use a lower flow rate in the block after the Watch instruction than used when the Watch instruction was activated.

Feedback tuning can also be added manually to a method in the **Method Editor** module.

Feedback tuning instructions

Feedback tuning can also be used when running the system pump manually. The instructions are found in the System Control module by selecting **Manual:Pump** and are explained in Table 2-1.

Table 2-1. Feedback tuning instructions

Instruction	Parameter description
SystemPumpControlMode	To activate feedback tuning, select PressFlowControl . PressLevel is the pressure control set point MinFlow is the minimum allowed flow rate

Instruction	Parameter description
SystemPIDParameters	<p>Flow_P, Flow_I and Flow_D are the parameters for tuning the actual flow rate to the set flow rate. Active below the PressLevel value.</p> <p>Press_P, Press_I and Press_D are the parameters for reducing the flow rate and thereby decreasing the pressure to below the pressure set point. Active above the PressLevel value.</p>

Optimizing the PID parameters

The two regulators for the system pump have separate PID parameters. The default PID parameters in UNICORN provide a robust feedback tuning that is suitable for most purposes. However, the parameters can be further optimized to suit a specific application.

The table below describes the three PID parameters.

Table 2-2. PID parameters

Parameter	Description
P	The P parameter reduces the effect of an error but does not completely eliminate it. A simple P-regulator results in a stable stationary error between actual and requested flow.
I	The I parameter eliminates the stationary error, but results in a slight instability leading to oscillations in the actual flow. The I parameter can have values between 0 and infinity. Smaller values have a greater effect and a value of infinity has no effect. Note: <i>The value infinity is set as 9999 in UNICORN.</i>
D	In certain cases, the D parameter can reduce the oscillations introduced by a PI-regulator. D can have values between 0 and infinity, where larger values have a greater effect and a value of 0 has no effect. Note: <i>Most often, a simple PI-regulator is preferable for control of flow rate and ÅKTAexplorer is therefore configured by default with the D parameter set to zero.</i>

Rules of thumb for optimizing the PID parameters:

- Use the default parameter values as a start. To set the default values, select **System:Settings** in the **System Control** module. The parameters are found in **Specials**.
- Keep the D parameter set to zero, i.e. use a simple PI-regulator.

- Start the pump before activating the regulator.
- Increasing P makes the regulator faster.
- Increasing I reduces oscillations.

See also the *UNICORN Administration and Technical Manual* for more information about feedback tuning.

2.12.2 Feedback tuning of the sample pump

Tuning principle

The feedback tuning of the sample pump is simpler than the feedback tuning of the system pump. When the pressure reaches the maximum allowed pressure, the flow is decreased. After a short while, the flow slowly increases towards the set flow rate, and so on.

The tuning regulator is rather simple and does not use PID-parameters. The parameters that control the tuning characteristics can not be changed.

Feedback tuning of the sample pump in a method

- 1 To include feedback tuning in the **Method Wizard**, select **Sample Pump Direct Loading** in the **Sample Injection** dialog.
- 2 Select **Pressure Control** for **Sample pump**.
The default value for the maximum allowed pressure is 2.0 MPa and for the minimum allowed flow 0.1 ml/min.
- 3 Click **Finish** in the last dialog.

Note: *If the flow rate falls below the MinFlow value, an Alarm is raised and the system set to Pause. Therefore, we recommend using a Watch instruction (WatchPar_SampleFlow_960) for the flow that is activated above this value. A suitable action is to continue to the next block.
To prevent pressure peaks when continuing, use a lower flow rate in the block after the Watch instruction than used when the Watch instruction was activated.*

Feedback tuning can also be applied in an existing method made with the Method Wizard in the **Method Editor** module.

To change the maximum allowed pressure:

Alternative 1

- 1 Select **View:Run Setup**. Select the **Variables** page.
- 2 Select **Show details**.
- 3 Change the variable under block **Alarm_Sample_PressureLimit**.

Alternative 2

- 1 Select **View:Text Instructions**.
- 2 Expand Block **Alarm_Sample_PressureLimit**.
- 3 Select the **Alarm_SamplePressure_960 instruction**.
- 4 Type the desired **HighAlarm** value (maximum allowed pressure) in the **Parameters** field.

To change the minimum allowed flow:

Alternative 1

- 1 Select **View:Run Setup**. Select the **Variables** page.
- 2 Select **Show details**.
- 3 Change the variable under block **PressureReg_Sample_Pump**.

Alternative 2

- 1 Select **View:Text Instructions**.
- 2 Expand **Block Direct_Sample>Loading**.
- 3 Expand **Block PressureReg_Sample_Pump**.
- 4 Select the **SamplePumpControlMode_960 instruction**.
- 5 Type the desired **MinFlow** value (minimum allowed flow) in the **Parameters** field.

Feedback tuning with manual instructions

To use feedback tuning when running the sample pump manually:

- 1 In **System Control** select **Manual:Alarms&Mon**.
- 2 Select **Alarm_SamplePressure_960**.
- 3 Select **Enabled** and set the **HighAlarm** value (maximum allowed pressure). Click **Insert**.
- 4 Select **Pump** to switch to the **Pump Instructions** dialog. Select **SamplePumpControlMode_960**.
- 5 Select **PressFlowControl** and set the **MinFlow** value. Click **Execute** to start feedback tuning.

Note: Start the system pump with a low flow rate after running the sample pump with feedback tuning.

2 Operation
2.12 Feedback tuning

3 Maintenance

3.1 Periodic maintenance

Regular maintenance will help to keep your ÄKTAexplorer running smoothly. Follow the recommendations in this chapter to keep the system in good working order.

Do not allow spilled liquid to dry on the instrument. Wipe the surface regularly with a damp cloth. Let the system dry completely before using it.

For details on how to perform the various actions, please refer to the individual User Manuals and Instructions.

3.2 Recycling



This symbol indicates that the waste of electrical and electronic equipment must not be disposed as unsorted municipal waste and must be collected separately. Please contact an authorized representative of the manufacturer for information concerning the decommissioning of equipment.



WARNING! Remove liquid or dirt from the system surface using a cloth and, if necessary, a mild cleaning reagent.



WARNING! Always disconnect the power supply before attempting to replace any item on the system during maintenance.



WARNING! If there is a risk that large volumes of spilled liquid may penetrate the casing of the instruments and come into contact with the electrical components, immediately switch off the system and contact an authorized service technician.



WARNING! When using hazardous chemicals, make sure that the entire system has been flushed thoroughly with bacteriostatic solution, e.g. NaOH, and distilled water before service and maintenance.

3 Maintenance

3.2 Recycling



WARNING! When using hazardous chemicals, take all suitable protective measures, such as wearing protective glasses and gloves resistant to the chemicals used. Follow local regulations and instructions for safe operation and maintenance of the system.



WARNING! NaOH is injurious to health. Avoid spillage.



WARNING! Only spare parts that are approved or supplied by GE Healthcare may be used for maintaining or servicing the system.



WARNING! Use ONLY tubings supplied by GE Healthcare to ensure that the pressure specifications of the tubings are fulfilled.



WARNING! If the system is turned or the fraction collector removed, the external capillaries and other tubing may become entangled in nearby objects and be pulled from their connections causing leakage.

The following table lists the maintenance operations that should be performed by the user at regular intervals.

Interval	Action
Every day	
System	<ul style="list-style-type: none"> Inspect the complete system for eluent leakage. The system can be left filled with buffer overnight. If you are not using the separation unit for a few days, wash the flow path with distilled water. Remove the column and the pH electrode (if applicable). Replace the column by a bypass capillary and fit the pH dummy electrode. Then wash the system with 20% ethanol and store it in 20% ethanol. Make sure that all tubing and all flow paths used are rinsed.
pH electrode	<ul style="list-style-type: none"> Calibrate the pH electrode (if applicable) according to chapter 3 in the <i>Monitor pH/C-900 User Manual</i>.
Pump P-900	<ul style="list-style-type: none"> Check for leakage. If there is a sign of liquid leaking between the pump head and the housing side panel or increased or decreased volume of rinsing solution, replace the piston seals, refer to chapter 4 in <i>Pump P-900 User Manual</i>. When changing eluent, it is important to remove trapped air. Purge the pump according to chapter 2 in the <i>Pump P-900 User Manual</i>. If there is still air in the inlet tubing, stop and remove the air bubbles according to chapter 5 in the <i>Pump P-900 User Manual</i>. <p>Note: <i>If air is allowed to enter the columns, their performance can be heavily altered or destroyed.</i></p>
Every week	
Inlet filters	<ul style="list-style-type: none"> Check the inlet filters visually and replace them if necessary.
On-line filter	<ul style="list-style-type: none"> Replace the on-line filter.

Interval	Action
Pump rinsing solution	<ul style="list-style-type: none"><li data-bbox="592 282 1127 354">• Change rinsing solution. Always use 20% ethanol as rinsing solution. <p data-bbox="637 364 1127 527">If the volume of rinsing solution in the storage bottle has increased, it can be an indication of internal pump leakage. Replace the piston seals according to chapter 4 in <i>Pump P-900 User Manual</i>.</p> <p data-bbox="637 536 1127 673">If the volume of rinsing solution in the storage bottle has decreased significantly, check if the rinsing system connectors are mounted properly.</p> <p data-bbox="637 682 1127 840">If the rinsing system connectors are not leaking, the rinsing membranes or piston seals may be leaking. Replace the membranes and piston seals according to chapter 4 in <i>Pump P-900 User Manual</i>.</p>

Interval	Action
Every month	
Flow restrictor	<ul style="list-style-type: none"> • Check that flow restrictor generates the following back-pressure: <ul style="list-style-type: none"> FR-904: 0.4 ±0.05 MPa FR-902: 0.2 ±0.05 MPa <p>Check the back-pressure as follows:</p> <ol style="list-style-type: none"> 1 Disconnect the flow restrictor. 2 Connect a capillary (approx. 1 m, i.d. 1 mm) to a free port in valve V2. Set the valve manually to this port. Put the open end in a waste container. 3 Run the pump at 10 ml/min with water. Note the back-pressure (Bp1) on the pump display, or in the Run Data window. 4 Connect the flow restrictor to the open end of the capillary (observe the IN marking). Put the flow restrictor in the waste container. 5 Run the pump at 10 ml/min with water. Note the back-pressure (Bp2) on the pump display, or in the Run Data window. 6 Calculate the back-pressure generated by the flow restrictor. Replace it if it is not within limit.
Every 3 months	
Monitor UV-900	<ul style="list-style-type: none"> • Check the instrument according to chapter 4 in Monitor UV-900 User Manual.
Every 6 months	
Monitor UV-900	<ul style="list-style-type: none"> • Clean the cell and optical fibre connectors according to chapter 4 in <i>Monitor UV-900 User Manual</i>.

Interval	Action
Monitor pH/C-900	<ul style="list-style-type: none"> • Clean the UV flow cells according to chapter 4 in <i>Monitor pH/C-900 User Manual</i>. Cleaning the flow cells might be required more often if crude samples are regularly used. • Check the pH electrode according to chapter 3 in <i>Monitor pH/C-900 User Manual</i>. Replace the pH electrode if necessary.
Mixer M-925	<ul style="list-style-type: none"> • Check that the mixer chamber is clean and without damage. Check the tubing connectors. Replace if required.
Yearly	
Valve INV-907, IV-908 and PV-908	<ul style="list-style-type: none"> • Check for external or internal leakage. Replace channel plate and distribution plate yearly or when required. Refer to chapter 4 of the relevant valve instruction sheet
Every 2 years	
Mixer M-925	<ul style="list-style-type: none"> • Replace the complete mixing chamber on a regular basis.
When required	
Pump P-900	<ul style="list-style-type: none"> • Replace piston seals. Refer to chapter 4 in <i>Pump P-900 User Manual</i>. • Replace piston. Refer to chapter 4 in <i>Pump P-900 User Manual</i>. • Clean or replace the inlet and outlet check valves. Refer to chapter 4 in <i>Pump P-900 User Manual</i>.
Monitor pH/C-900	<ul style="list-style-type: none"> • Clean the conductivity flow cell according to chapter 4 in <i>Monitor pH/C-900 User Manual</i>. • Clean the pH electrode flow cell (if applicable) according to chapter 4 in <i>Monitor pH/C-900 User Manual</i>.
Pump P-960	<ul style="list-style-type: none"> • The pressure offset of Pump P-960 must be calibrated whenever the running conditions are changed, e.g. viscosity of sample or buffer, temperature, back-pressure etc.

3.3 Cleaning the system

The protocols described below are for system cleaning.



WARNING! When using hazardous chemicals, make sure that the entire system has been flushed thoroughly with bacteriostatic solution, e.g. NaOH and distilled water before service and maintenance.

The column selection valves should be set to column bypass position. If the column is to be left in the flow path, please observe the rated maximum flow and pressure for the column.

For column cleaning procedures and column storage instructions, please refer to the Instruction supplied with the column.

3.3.1 At the end of the day

If the system will be used with the same buffers next day, let the system run isocratic at a low flow rate (10% of the used flow rate).

If the system will be used with other buffers next day, rinse the pump and the system with distilled water using the **PumpWashExplorer** instruction as follows:

- 1 Submerge the inlet tubings in distilled water.
- 2 Run the PumpWashExplorer instruction. Refer to the UNICORN User Manuals for detailed instructions.

It is also possible to perform a **SystemWash**. During the **SystemWash** the system is set to Pause, the column position to Position 1 Bypass, and the flow is diverted to Waste via the outlet valve. The valves and the flow rate will return to their previous settings after the wash:

Note: *The pumps must be purged prior to SystemWash.*

- 1 Choose an Inlet A1 prior to SystemWash.
- 2 Run the **SystemWash** instruction. Refer to the *UNICORN User Manuals* for detailed instructions.

3.3.2 Leaving for a few days

Perform a **PumpWashExplorer** with distilled water. Repeat with a bacteriostatic solution, 20% ethanol (not the pH electrode, see separate instruction below).

Alternatively perform a **SystemWash**, see instructions above.

pH electrode (if applicable): The pH electrode should always be stored in a 1:1 mixture of pH 4 buffer and 2 M KNO₃ when not in use. When the pH electrode is

3 Maintenance

3.3 Cleaning the system

removed from the flow cell, the dummy electrode (supplied) can be inserted in the flowpath.

CAUTION! Never leave the pH electrode in the electrode holder for any period of time when the system is not used, since this might cause the glass membrane of the electrode to dry out. Remove the pH electrode from the flow cell and fit the end cover filled with a 1:1 mixture of pH 4 buffer and 2 M KNO₃. Do NOT store in water only.

3.3.3 Additional wash of outlet valve and sample valve inlet tubing.

A **SystemWash** does not include wash of the outlet and sample valves¹. Wash the valves as follows:

Outlet valve: In system control, start the system flow rate. Rinse the valve by switching between the ports manually from system control.

Sample valve: Place all the sample inlet tubing in the washing solution. Start the sample pump and rinse the valve by switching between the ports manually from system control.

3.3.4 Monthly cleaning

Clean the system every month or when problems such as ghost peaks occur.

Wash with 1M NaOH using the **SystemWash** instruction. Immediately wash the system with distilled water to rinse the system from NaOH.

3.3.5 Cleaning-in-place

After repeated separation cycles, contaminating material might progressively build up in the system and on the column. This material may not have been removed by the cleaning step described above. The nature and degree of contamination depends on the sample and the chromatographic conditions employed. These should be considered when designing a cleaning protocol.

A method for cleaning-in-place, **CIP**, is available in the UNICORN Method Wizard. It gives many possibilities to design a powerful cleaning protocol for individual problems, with up to 9 cleaning segments.

¹ The sample valve is optional in ÄKTAexplorer 10.

3.4 *Moving the system*

Two persons are required to lift the system.



CAUTION! Never lift the system by the valves or the valve door.

WARNING! When using hazardous chemicals, make sure that the entire system has been flushed thoroughly with bacteriostatic solution, e.g. NaOH, and distilled water before service and maintenance.

Before moving the system, disconnect all cables and tubing connected to peripheral components and liquid containers. Remove all items from the top of the system. Close the valve door completely. Grasp the system firmly by placing the fingers in the gap between the swivel platform and the base of the main unit and lift.

3 Maintenance
3.4 Moving the system

4 Troubleshooting

4.1 *Faults and actions*

This section lists faults observed from specific monitor curves and specific modules. The faults and actions are listed as follows:

Monitor curve/Component	Page
UV curve	76
Conductivity curve	78
pH curve	79
Pressure curve	82
Monitor UV-900	82
Monitor pH/C-900	83
Pump P-900	83
Mixer M-925	85
Pump P-960	86
Valve SV-903	86
Valve IV-908, PV-908, INV-907	87
BufferPrep	88

If the suggested actions do not correct the fault, call GE Healthcare.

4.2 *Recycling*



This symbol indicates that the waste of electrical and electronic equipment must not be disposed as unsorted municipal waste and must be collected separately. Please contact an authorized representative of the manufacturer for information concerning the decommissioning of equipment.

4.3 UV curve

Error symptom	Possible cause/Action
<i>Ghost peaks</i>	<ul style="list-style-type: none">• Check that there is no air in the eluents. Degas if necessary.• Clean the system in accordance with Section 3.3.• Clean the column in accordance with the column instructions.• Check that the mixer is functioning correctly and that the correct chamber volume is being used. The mixer function is checked by placing a stirrer bar on top of the mixer housing. The stirrer bar should rotate when the system is in Run mode. The mixer function can also be checked by running the installation test.

Error symptom	Possible cause/Action
Noisy UV-signal, signal drift or instability	1 The buffer may be impure. Check if the signal is still noisy with water.
	2 There may be air in the flow cell. Check that flow restrictor generates the following back-pressure:
	FR-904: 0.4 ±0.05 MPa
	FR-902: 0.2 ±0.05 MPa
	Check the back-pressure as follows:
	a) Disconnect the flow restrictor. b) Connect a capillary (approx. 1 m, i.d. 1 mm) to a free port in valve V2. Set the valve manually to this port. Put the open end in a waste container. c) Run the pump at 10 ml/min with water. Note the back-pressure (Bp1) on the pump display, or in the Run Data window. d) Connect the flow restrictor to the open end of the capillary (observe the IN marking). Put the flow restrictor in the waste container. e) Run the pump at 10 ml/min with water. Note the back-pressure (Bp2) on the pump display, or in the Run Data window. f) Calculate the back-pressure generated by the flow restrictor. Replace it, if it is not within limit.
3 Degas the buffer before use.	
4 Check the connections of the UV-cell optical fibres.	
5 Clean the UV-cell, see chapter 4 of <i>Monitor UV-900 User Manual</i> .	
6 Air might be trapped in the pump. Purge the pump according to <i>Pump P-900 User Manual</i> .	

4.4 Conductivity curve

Error symptom	Possible cause/Action
Baseline drift or noisy signal	<ol style="list-style-type: none"> 1 There may be air in the flow cell. Be sure to use a flow restrictor after the flow cell. 2 Check for leaking tubing connections. 3 Check that the column is equilibrated. If necessary clean the column. 4 Check the operation of the mixer and the pump. The mixer function is checked by placing a stirrer bar on top of the mixer housing. The stirrer bar should rotate when the system is in Run mode. The mixer function can also be checked by running the installation test. 5 Clean the flow cell according to procedure in chapter 4 of <i>Monitor pH/C-900 User Manual</i>.
Conductivity measurement with the same buffer appears to decrease over time	<ol style="list-style-type: none"> 1 Clean the flow cell according to procedure in chapter 4 of <i>Monitor pH/C-900 User Manual</i>. 2 The ambient temperature may have decreased. Use a temperature compensation factor, see Reference information in <i>Monitor pH/C User Manual</i>.
Waves on the gradient	<ol style="list-style-type: none"> 1 Check that the pump is operating and is programmed correctly. 2 Check that the mixing chamber is free from dirt or particles. 3 Change to a larger mixing chamber volume if necessary. 4 Check the motor operation. Place a hand on the mixer and start it by starting the pump at a low flow rate. You should both hear and feel the mixer motor and stirrer when they are spinning.
Ghost peaks appear in the gradient profile	<ol style="list-style-type: none"> 1 A charged sample has been detected (e.g. protein). 2 Air bubbles are passing through the flow cell. Check for loose tubing connections. Use the flow restrictor.

Error symptom	Possible cause/Action
<i>Unlinear gradients or slow response to %B changes</i>	<ol style="list-style-type: none"> 1 Check that the tubing has been washed properly and that the pump is operating. 2 Change to smaller mixer volume.
<i>Incorrect or unstable reading</i>	<ol style="list-style-type: none"> 1 Check that the conductivity flow cell cable is connected properly to the rear of the instrument. 2 Check that the pump and valves operate correctly. 3 If temperature compensation is being used, check that the temperature sensor is calibrated, and that the correct temperature compensation factor is in use. 4 Check that the column is equilibrated. If necessary clean the column. 5 Check the operation of the mixer. The mixer function is checked by placing a stirrer bar on top of the mixer housing. The stirrer bar should rotate when the system is in Run mode. The mixer function can also be checked by running the installation test.

4.5 pH curve

Error symptom	Possible cause/Action
<i>No response to pH changes</i>	<ol style="list-style-type: none"> 1 Check that the electrode cable is connected properly to the rear of the instrument. 2 The electrode glass membrane may be cracked. Replace the electrode.
<i>Small response to pH changes</i>	<ol style="list-style-type: none"> 1 Clean the pH electrode as detailed in chapter 4 of the <i>Monitor pH/C-900 User Manual</i>. 2 If the problem remains, replace the pH electrode.

Error symptom	Possible cause/Action
<i>Slow pH response or Calibration impossible</i>	<ol style="list-style-type: none"> 1 Check the electrode glass membrane. If it is contaminated, clean the electrode following the instructions in chapter 4 of the <i>Monitor pH/C-900 User Manual</i>. 2 If the membrane has dried out, the electrode may be restored by soaking it in buffer overnight.
<i>Incorrect or unstable pH reading</i>	<ol style="list-style-type: none"> 1 Check that the electrode cable is connected properly to the rear of the instrument 2 Check that the pump and valves operates correctly. 3 Check that the electrode is correctly inserted in the flow cell and, if necessary, hand-tighten the nut. 4 If air in the flow cell is suspected, tap the flow cell carefully or tilt it to remove the air. Alternatively, flush the cell with buffer at 20 ml/min (E 100 system) or 10 ml/min (E 10 system) for 1/2 min. Use the flow restrictor FR-902 after the pH electrode. 5 Check that the pH electrode is not broken. 6 Calibrate the pH electrode. 7 Check the slope (see chapter 3 of the <i>MonitorpH/C-900 User Manual</i>). If it is outside the range 80–105% or the asymmetry potential deviates more than 60 mV from 0 mV, clean the pH electrode. Recalibrate and if the problem persists, replace the pH electrode. 8 Clean the pH electrode if required, see chapter 4 of the <i>Monitor pH/C-900 User Manual</i>. 9 Compare the response of the pH electrode with that of another pH electrode. If the response differ greatly, the electrode may require cleaning or replacement.

Error symptom	Possible cause/Action
<i>Incorrect unstable pH reading</i>	<p>10 Compare the response of the pH electrode with that of another pH electrode. If the response differ greatly, the electrode may require cleaning or replacement.</p> <p>11 There may be interference from static fields. Connect the pH flow cell and the rear panel of the monitor using a standard laboratory 4 mm "banana plug" cable.</p> <p>12 Check that the pH electrode has been calibrated at the correct temperature.</p> <p>13 In organic solvents such as ethanol, methanol and acetonitrile, stable pH measurements are not possible since dehydration of the membrane will occur. It is recommended that the pH electrode is not used in applications using organic solvents. Mount the dummy electrode instead.</p> <p>14 Clogged liquid junction. Refer to chapter 4 of the <i>Monitor pH/C-900 User Manual</i>.</p>
<i>pH values vary with varied back pressure</i>	Replace the pH electrode.

4.6 Pressure curve

Error symptom	Possible cause/Action
<i>Erratic flow, noisy baseline signal, irregular pressure trace</i>	<p>Air bubbles passing through or trapped in the pump:</p> <ol style="list-style-type: none"> 1 Check all connections for leaks. 2 Check that there is sufficient eluent present in the reservoirs. 3 Use degassed solutions. 4 Purge the pump. 5 Follow the instructions in chapter 5 of <i>Pump P-900 User Manual</i>. <p>Inlet or outlet check valves not functioning correctly:</p> <ul style="list-style-type: none"> • Clean the valves in according to chapter 4 of <i>Pump P-900 User Manual</i>. <p>Piston seal leaking:</p> <ul style="list-style-type: none"> • Replace the piston seal according to the instructions in chapter 4 of <i>Pump P-900 User Manual</i>. <p>Blockage or part blockage of flowpath:</p> <ul style="list-style-type: none"> • Flush through to clear blockage. • If necessary, replace tubing. • Check inlet tubing filter. It can become clogged if unfiltered buffers or samples are applied. See instructions for flushing through at the end of the run in chapter 3 of <i>Pump P-900 User Manual</i>.

4.7 Monitor UV-900

Error symptom	Possible cause/Action
<i>No text on the front display</i>	<ol style="list-style-type: none"> 1 Check that the mains cable is connected and the power switch is in ON-position 1.
<i>Unstable baseline</i>	<ol style="list-style-type: none"> 1 Try using a larger mixer chamber instead of the standard mixer chamber.

4.8 Monitor pH/C-900

Error symptom	Possible cause/Action
No text on the front display	1 Check that the mains cable is connected and the power switch is in ON-position 1.
Absolute conductivity value wrong	1 Turn the flow cell so that the end with the screws is facing the pH flow cell. 2 Bad calibration. Recalibrate the conductivity cell. 3 Calibration solution, 1.00 M NaCl, not correctly prepared. Prepare a new calibration solution and recalibrate the conductivity cell. 4 If temperature compensation is being used, check that the temperature sensor is calibrated, and that the correct temperature compensation factor is in use. 5 Check that the temperature sensor is working correctly.
Unstable conductivity curve	1 Try using a larger mixer chamber instead of the standard mixer chamber.

4.9 Pump P-900

Error symptom	Possible cause/Action
No text on the front display	1 Check that the mains cable is connected and the power switch is in ON-position 1.
Liquid leaking between the pump head and the side panel	Piston seal or rinsing membrane incorrectly fitted or worn. 1 Replace or re-install the seal or the membrane. 2 Run-in carefully, see chapter 4 of <i>Pump P- 900 User Manual</i> .

Error symptom	Possible cause/Action
<i>Leaking connection and/or crystallized material around a connector</i>	<ol style="list-style-type: none">1 Unscrew the connector and check if it is worn or incorrectly fitted. If so replace the connector.2 Gently tighten the connector with your fingers.3 Restart the system and the pump.
<i>Low eluent flow and noise</i>	<ol style="list-style-type: none">1 Disassemble the pump head and examine the piston spring as the pistons move according to chapter 4 of <i>Pump P-900 User Manual</i>. Replace if necessary.2 If the spring is corroded, check piston seal and rinse membrane. Make sure that piston rinsing system is always used when working with aqueous buffers with high salt concentration.3 Check the piston for damage. If damaged, replace the piston according to chapter 4 of <i>Pump P-900 User Manual</i>.4 Remember to replace the piston seal and rinse membrane with new items.

Error symptom	Possible cause/Action
<i>Erratic pump pressure</i>	<p>To check the pump function, a recording of the pressure can be made, or by checking the pressure in UNICORN. By observing the piston stroke indicator in the Check menu together with the pressure trace, the pump head which is functioning abnormally can be identified (see Reference information in the <i>Pump P-900 System Manual</i>).</p> <p>There can be several causes of an abnormal pressure recording, for example:</p> <ul style="list-style-type: none"> • air trapped in the pump heads • partially blocked solvent filters • leaking connections • piston seal leakage • check valve malfunction • piston damaged <p>Some examples of normal and abnormal pressure traces together with comments are shown in chapter 5 of <i>Pump P-900 User Manual</i>.</p>

4.10 Mixer M-925

Error symptom	Possible cause/Action
<i>Leakage</i>	<ol style="list-style-type: none"> 1 Check the tubing connections. Retighten or replace if necessary. 2 Check the mixer chamber. Replace if liquid has penetrated the mixer chamber walls and sealings.

4.11 Pump P-960

Error symptom	Possible cause/Action
<i>Leakage</i>	<ol style="list-style-type: none"> 1 Check all tubing connections for leakage. Replace connectors or connection block if necessary. 2 Check if there is damage to the inlet or outlet tubing. Replace if necessary.
<i>Erratic flow or pressure pulsation</i>	<ol style="list-style-type: none"> 1 Check the tubing connectors. 2 Check the solvent filter. 3 Air bubbles may be trapped in the pump. Purge the pump according to the <i>Pump P-960 User Manual</i>.
<i>Not running</i>	<ol style="list-style-type: none"> 1 Check that the system power is on. 2 Check the UniNet-2 connection (the indicator on the sample pump should have steady light). 3 Restart the system and the pump.

4.12 Valve SV-903

Error symptom	Possible cause/Action
<i>The valve is not switching</i>	<ol style="list-style-type: none"> 1 Check the connections 2 Check that the pump is operating and is programmed correctly.
<i>External leakage</i>	<ol style="list-style-type: none"> 1 Check the tubing connections. Tighten or replace if necessary.
<i>Internal leakage</i>	<ol style="list-style-type: none"> 1 Replace the valve.

4.13 Valve IV-908, PV-908, INV-907

Error symptom	Possible cause/Action
<i>The valve is not switching</i>	<ol style="list-style-type: none"> 1 Check the connections to the pump. The valve should be connected to the UniNet 2 socket, not the UniNet-1 socket. 2 Check the ID-switch on the valve. The ID number should correspond to the number set in UNICORN. 3 Check the UniNet cable and replace if required.
<i>The valve is switching to the wrong position</i>	<p>The valve parts may have been incorrectly assembled after replacement.</p> <ol style="list-style-type: none"> 1 Check that the distribution plate marking i/o or 3 is horizontal. Refer to chapter 4 of the relevant valve instruction sheet.
<i>External leakage</i>	<ol style="list-style-type: none"> 1 Check the tubing connections. Tighten or replace if necessary.
<i>Internal leakage</i>	<p>Internal leakage can be detected at the small hole on the underside of the valve body.</p> <ol style="list-style-type: none"> 1 Internal valve parts may be worn. Change channel plate and distribution plate according to chapter 4 of the relevant valve instruction sheet.
<i>High back-pressure</i>	<ol style="list-style-type: none"> 1 Do cleaning-in-place according to the instructions in Section 4 of the relevant valve instruction sheet. 2 Change channel plate and distribution plate according to Chapter 4 of the relevant valve instruction sheet.

4.14 BufferPrep

Error symptom	Possible cause/Action
<i>Incorrect pH</i>	<ol style="list-style-type: none">1 Collect some eluent. Check the pH electrode calibration by measuring the pH of the collected eluent on a separate pH monitor.2 When using standard recipes, use the following mixture to measure the pH separately. Mix, using a 25 ml pipette, 25 ml of the buffer stock solution, 25 ml of the acid and 50 ml of water. Check the pH with a known good quality pH electrode. The reading should be close to: 5.0–9.5 pH AIEX pH 6.5 6.0–9.0 pH AIEX pH 6.1 3.0–7.5 pH CIEX pH 3.7 If not, prepare new buffers.3 If mixture pH is correct: Check for a dirty or broken pH electrode. Check that the valves are operating correctly.4 If a non-standard recipe is used: Check that the pH is not set too far from the pKa of the buffer components. Check if there is too low concentration of buffer components causing low buffering capacity. Check that the correct pKa values are used and that all pKa values have been entered.
<i>Drifting pH</i>	<ol style="list-style-type: none">1 Set the injection valve to position WASTE. Pump through at least 30 ml of buffer at the set pH to stabilize the pH. Switch the valve back to position LOAD. Equilibrate the column.

Error symptom	Possible cause/Action
<i>Unstable pH</i>	<ol style="list-style-type: none"> <li data-bbox="803 287 1199 378">1 Check the system by running the method without a column or sample. <li data-bbox="803 402 1199 778">2 If still unstable: Check that the correct mixer volume is used. Check that the pump is operating correctly. Check for a dirty or broken pH electrode. Check that the valves are operating correctly. Check that the pH is not set too far from the pKa of the buffer components. <li data-bbox="803 802 1199 1022">3 If the pH is stable when running without column or sample: Check if there is too low concentration of buffer components causing low buffering capacity. See also Section 5.3.5. Check the pH of the sample.

4 Troubleshooting

4.14 BufferPrep

5 Reference information

5.1 System description

5.1.1 The System

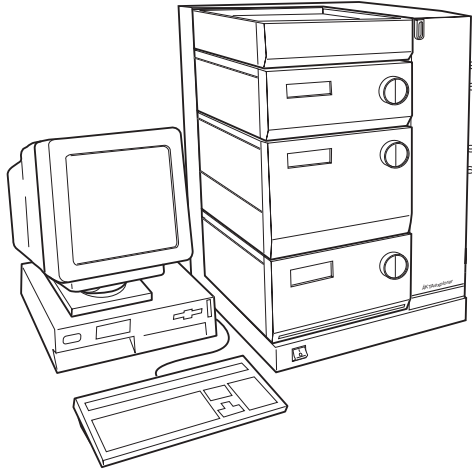

ÄKTAexplorer consists of a compact separation unit including modules and components, and a personal computer running UNICORN software version 4.12, or higher to control the separation unit. Fraction collectors are available as an accessory.

ÄKTAexplorer is described in detail in Section 5.1 of this manual and brief descriptions of the individual modules and components are given in Section 5.2. Detailed information on the modules and components can be found in their respective User Manuals and Instructions. UNICORN software is described in the separate *UNICORN User Manuals*.

Communication between the computer and the various modules and components of ÄKTAexplorer is achieved via high speed data network (UniNet-1 and UniNet-2).

Most of the fluid handling equipment of ÄKTAexplorer is mounted on the valve door, a fully opening section of the separation unit. This allows easy access to all components, tubing and other fluid items located on the modules.

5 Reference information
 5.1 System description

5.1.2 Component locations

The following illustrations show the locations of the standard components of the separation unit.

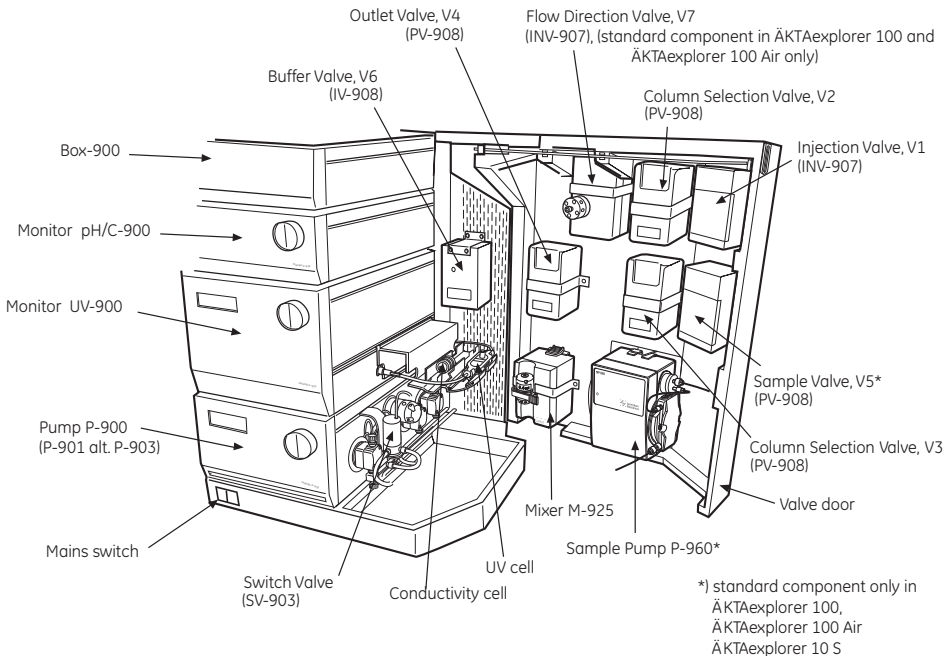
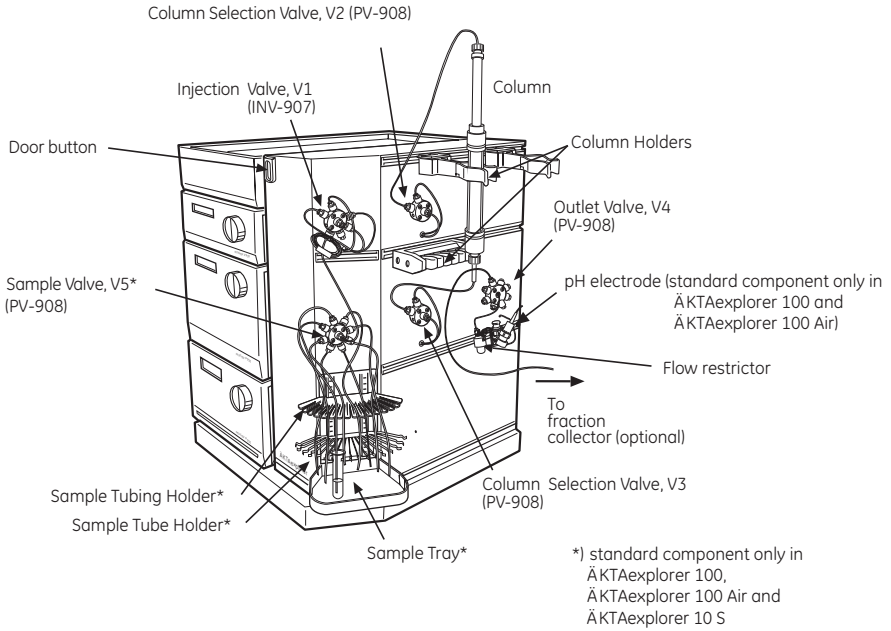

5.1.3 Electrical connections

All electrical connections for ÄKTAexplorer are located at the rear of the system. The system is mounted on a swivel platform allowing easy access to the fluid handling components and the electrical connections.



WARNING! Only use mains cables delivered and approved by GE Healthcare

Mains cables

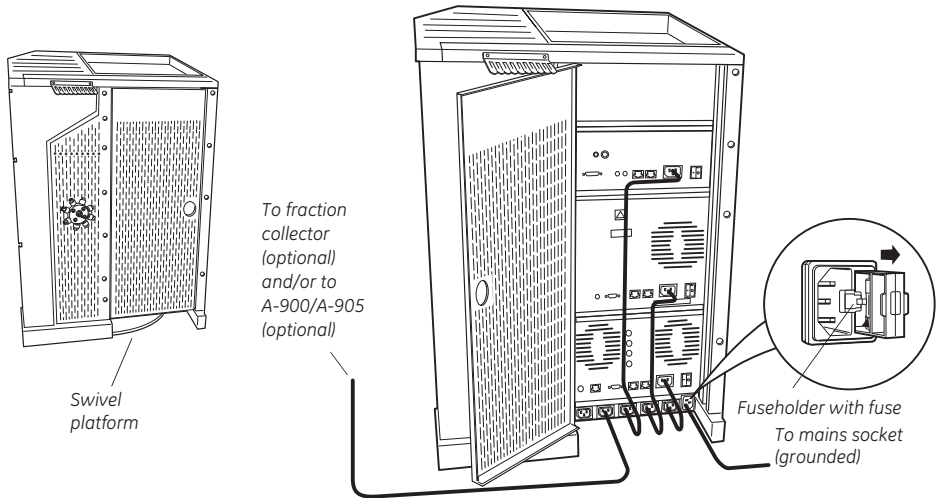

WARNING! Never attempt to remove the mains fuse while mains voltage is applied to the system. For continued protection against risk of fire, replace only with fuse of the specified type and rating. Please, refer to the Technical specifications for fuse data.

Only one mains input is required for the complete system. The supply voltage for the components in the system and the fraction collector (optional) is distributed from the base of the system. The mains input fuse is located to the right of the mains input. To open the fuse holder, after first removing the power to the system, use a small bladed screwdriver to lever the holder outwards.

UniNet-1 chain

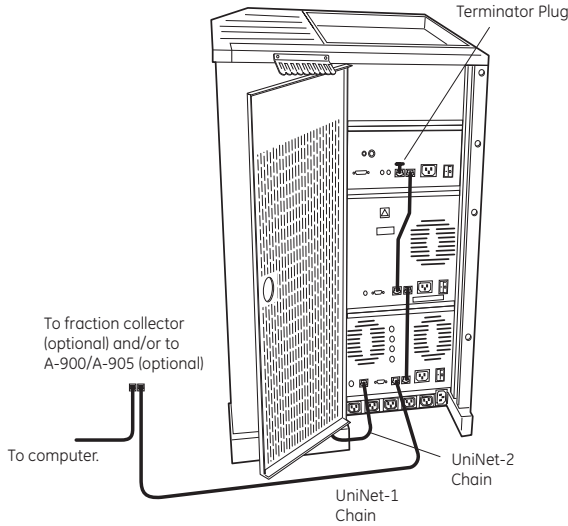

The UniNet-1 data communication chain comes from the computer via the fraction collector (optional) or to the rear of Pump P-900. The chain is terminated at Monitor pH/C-900 with a termination plug.

UniNet-2 chain in ÄKTAexplorer 10 and 10 S

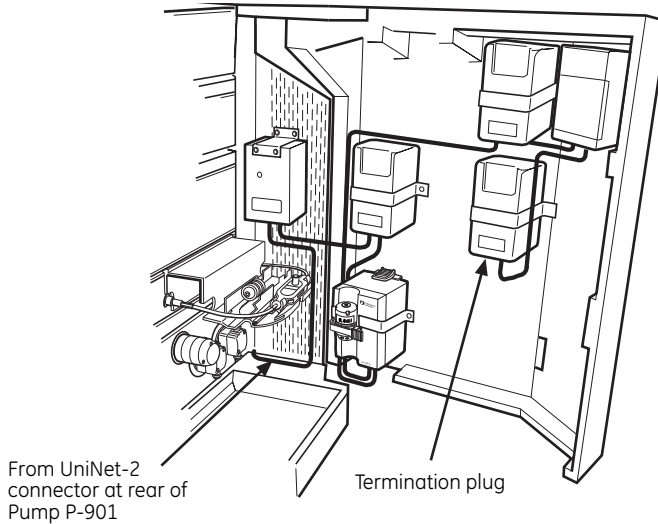

UniNet-2 chain in ÄKTAexplorer 100 and 100 Air

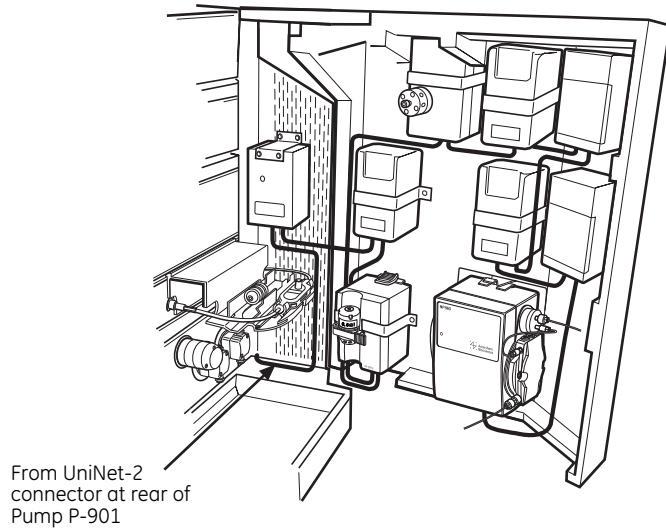

The UniNet-2 data communication chain, which controls the valves, the mixer and the sample pump (if applicable) in the system comes from the rear of Pump P-900 and links components inside the system. The chain is terminated at the column selection valve, V3, with a termination plug.

Sample pump P-960 is the last component in the UniNet-2 chain. P-960 has an internal termination.

5.1.4 Fluid Handling Path – ÄKTAexplorer 10

The following illustrations of the system show the positions of the components and tubing in ÄKTAexplorer 10. Refer to the flow diagram for their locations in the fluid handling path.

ÄKTAexplorer 10 S includes a sample pump and is therefore illustrated in the next section, *ÄKTAexplorer 100*.

5 Reference information

5.1 System description

Column Selection Valve, V2 (PV-908)

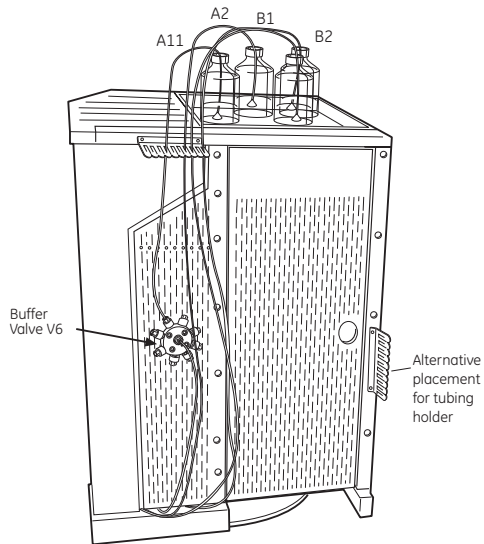
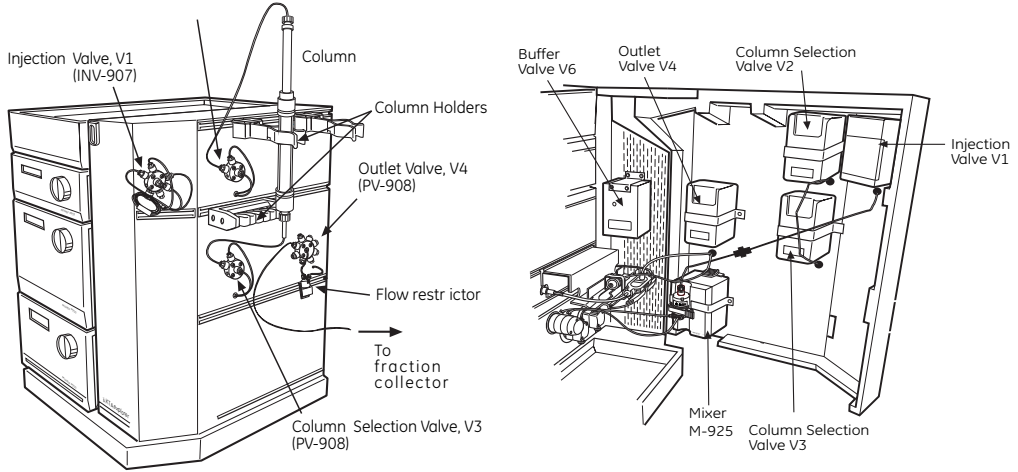

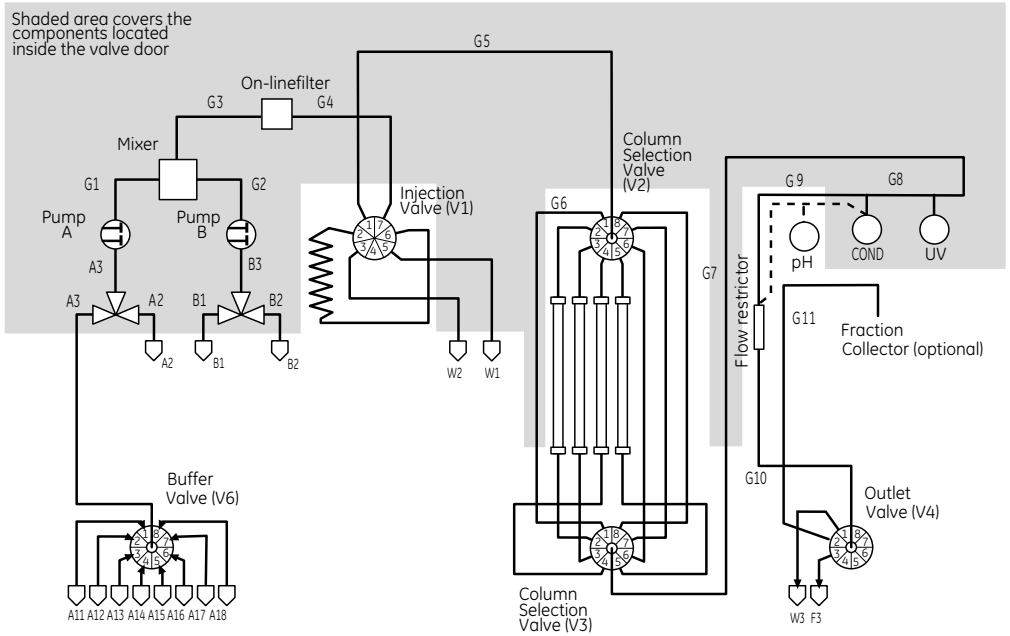

The table shows the tubing available for ÄKTAexplorer 10, and where they are located in the system. At delivery i.d. 0.5 mm PEEK tubing is installed from the pump to the injection valve, and i.d. 0.25 mm PEEK tubing from the outlet of the injection valve to the fraction collector (if applicable). The column is installed either by using the tubing supplied with the column or by using a piece of PEEK tubing cut by the user to suitable length (i.d. 0.25 mm and 0.50 mm PEEK tubing is supplied with the ÄKTAexplorer system).

5 Reference information

5.1 System description

Tubing i.d.	Tubing o.d.	Material	Color	Max. pressure	Volume of 10 cm	Connected from/to
0.25 mm	1/16"	PEEK	Blue	25 MPa	4.9 µl	From injection valve to fraction collector G5 + G7–G11). (Tubing kit 0.25, installed at delivery)
0.50 mm	1/16"	PEEK	Orange	25 MPa	19.6 µl	From Pump P-900 to injection valve (G1–G4 + G6). G6 is installed from factory, and is connected between V2 and V3 to bypass the column.
0.50 mm	1/16"	PEEK	Orange	25 MPa	19.6 µl	From injection valve to fraction collector (Tubing kit 0.50). F3=flowthrough (H5 + H7–H12, F3)
0.75 mm	1/16"	Tefzel	Clear	7 MPa	44.2 µl	Waste tubing (W1–W3)
1.6 mm	1/8"	Teflon	Clear	3.4 MPa	201.1 µl	Inlet tubing (A1–A3, B1–B3, A11–A18)

5.1.5 Fluid Handling Path – ÄKTAexplorer 100

The following illustrations of the system show the positions of the components and tubing in ÄKTAexplorer 100. Refer to the flow diagram for their location in the fluid handling path.

Note that the illustrations also apply to ÄKTAexplorer 10 S (components related to the sample pump are included).

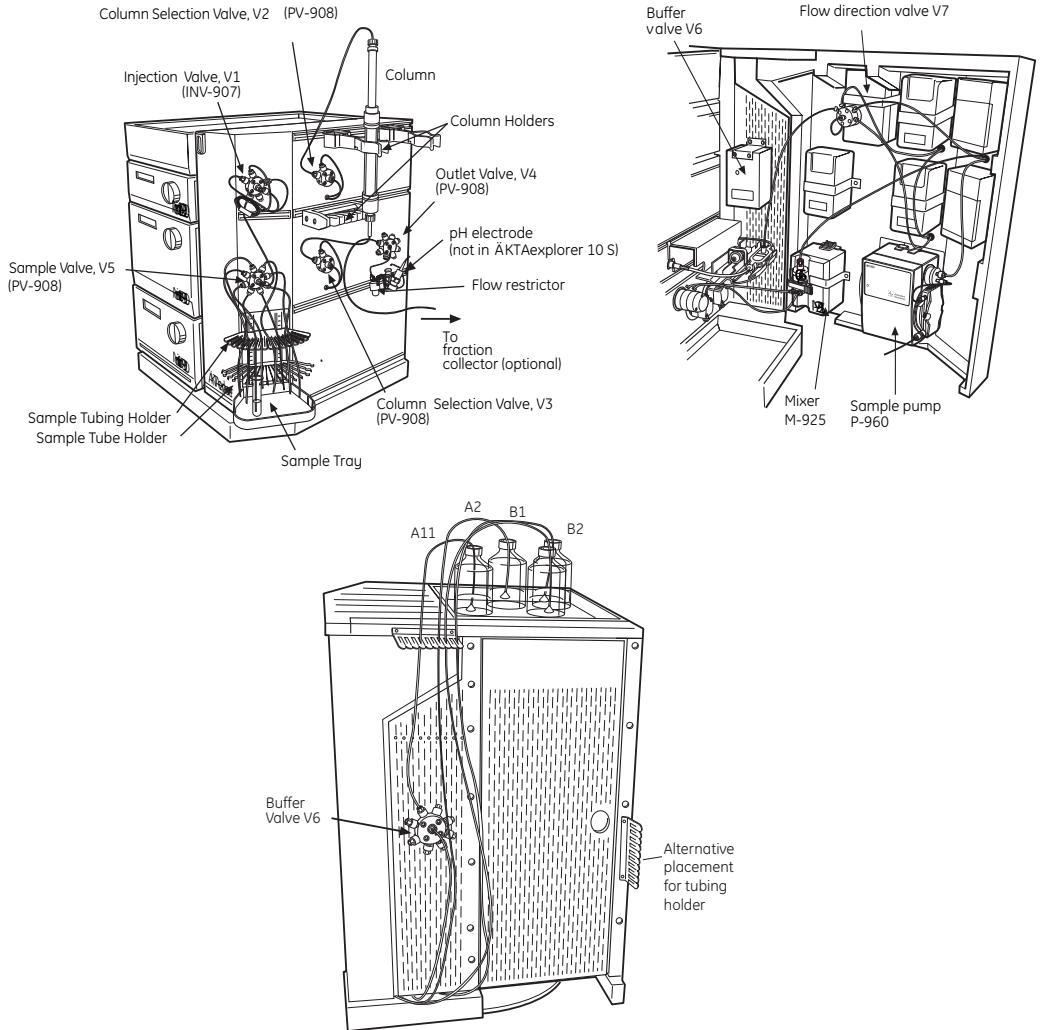

5 Reference information
 5.1 System description

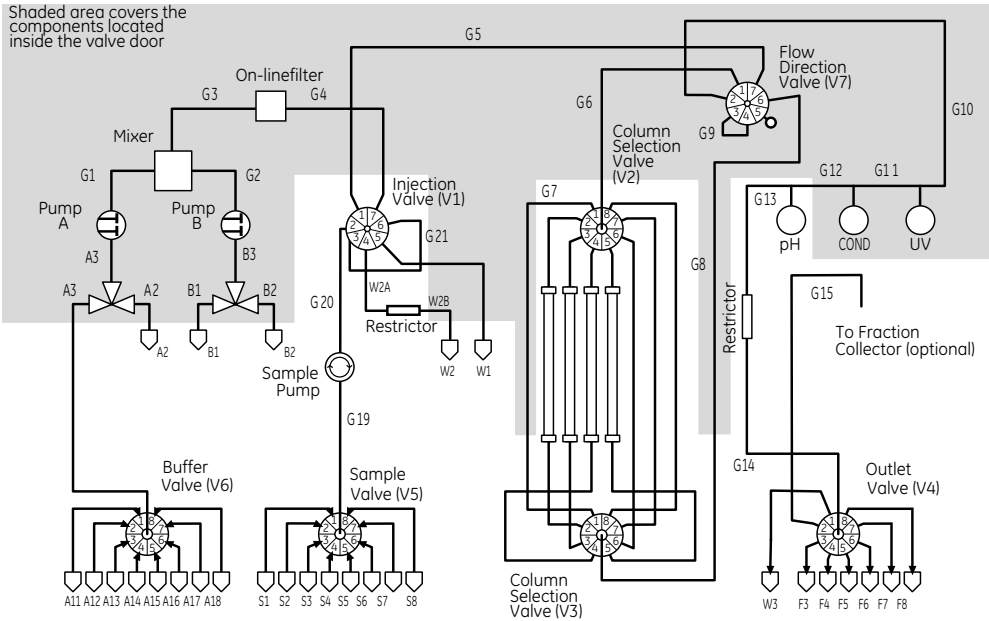

The table shows the tubing available for ÄKTAexplorer 100, and the location in the system. The tubing used depends on which tubing kit is installed. At delivery i.d. 0.75 mm tubing is installed.

Tubing i.d.	Tubing o.d.	Material	Color	Max. pressure	Volume of 10 cm	Connected from/to
0.5 mm	1/16"	PEEK	Orange	25 MPa	19.6 µl	From injection valve to UV flow cell (Tubing kit 0.5)
0.5 mm	1/16"	Tefzel	Clear	7 MPa	19.6 µl	From UV flow cell to fraction collector (Tubing kit 0.5)
0.75 mm	1/16"	PEEK	Green	10 MPa	44.2 µl	From Pump P-900 to UV flow cell. G21 (Installed at delivery)
0.75 mm	1/16"	Tefzel	Clear	7 MPa	44.2 µl	From UV flow cell to fraction collector (Installed at delivery)

Tubing i.d.	Tubing o.d.	Material	Color	Max. pressure	Volume of 10 cm	Connected from/to
1.0 mm	1/16"	PEEK	Grey	3.4 MPa	78.5 µl	From Pump P-900 to fraction collector (Tubing kit 1.0)
1.0 mm	1/16"	Tefzel	Clear	5 MPa	78.5 µl	From all inlets to Pump P-960 (Sample Valve kit 1.0). G19, G20, W2A, W2B, W1 (Installed at delivery).
2.9 mm	3/16"	Teflon	Clear	3.4 MPa	660 µl	From all inlets to Pump P-900 (Installed at delivery)

5.1.6 Changing tubing kits –ÄKTAexplorer 10

Two different tubing kits, with different internal diameters, are available for use from the injection valve to the outlet valve (or the fraction collector if applicable) in ÄKTAexplorer 10:

- Tubing kit 0.25 (G5, G7–G11). PEEK tubing, blue, marked G. Installed from factory at delivery. Used for most columns.
- Tubing kit 0.50 (H5, H7–H12). PEEK tubing, orange, marked H. For low-pressure columns, at high flow rates, and/or when the pH electrode is used.

The system is delivered with Tubing kit 0.25 installed. Tubing kit 0.50 should be fitted when columns with a low max pressure are used at high flow rates, or when the pH flow cell is installed to house the pH electrode.



WARNING! Incorrectly fitted tubing may loosen, causing a jet of liquid to spray out. This is especially dangerous if hazardous chemicals are in use. Connect the tubing by first inserting the tubing fully, then tightening the connector fingertight. PEEK tubing should be tightened a further 1/4 turn using the key supplied. Do not tighten Teflon tubing further as this will damage the end of the tubing.



WARNING! The bend radius of PEEK tubing must never be less than 10 cm (with the exception of heat treated, preformed tubing). A smaller radius decreases the allowed maximum pressure and the tubing might break.

5 Reference information
 5.1 System description



WARNING! Use ONLY tubings supplied by GE Healthcare to ensure that the pressure specifications of the tubings are fulfilled.

When changing from/to Tubing kit 0.25 to/from Tubing kit 0.50, change the tubings designated G5, G7–G11 with H5, H7–H12. Refer to the flow diagram in Section 5.1.4 for their location in the fluid handling path.

Note: *Tubing kit 0.50 contains one more capillary (H12) than Tubing kit 0.25. This is because the pH flow cell is not mounted from the factory.*

Tubing ¹	Length (mm)	i.d. (mm)	Location
Standard tubing			
G1	300	0.50	Pump P-900A (inner) to mixer (left)
G2	300	0.50	Pump P-900B (outer) to mixer (right)
G3	150	0.50	Mixer to on-line filter
G4	460	0.50	On-line filter to injection valve pos. 7
G6	620	0.50	Column valve V2 (port 1) to column valve V3 (port 1)
A3	150	1.6	SV-903A (IN) to Pump P-900A
B3	150	1.6	SV-903B (IN) to Pump P-900B
A11–A18	1250	1.6	Buffer vessels A11–A18 to buffer valve V6 (port 1–8)
A1	750	1.6	Buffer valve V6 (Center port) to SV-903A (NO)
A2	2000	1,6	Buffer vessels A2 to SV-903A (NC)
B1	1800	1,6	Buffer vessels B1 to SV-903B (NO)
B2	1800	1,6	Buffer vessels B2 to SV-903B (NC)
W1	1300	0.75	Injection valve (port 4) to waste
W2	1300	0.75	Injection valve (port 5) to waste
W3	1000	0.75	Outlet valve (port 1) to waste
F3	1000	0.50	Outlet valve (port 3, flowthrough)

Tubing ¹	Length (mm)	i.d. (mm)	Location
<i>Tubing kit 0.25 mm</i>			
G5	270	0.25	Injection valve pos. 1 to column valve V2 (center port)
G7	550	0.25	Column valve V3 (center port) to top of UV cell
G8	160	0.25	UV cell to conductivity cell
G9	450	0.25	Conductivity cell to flow restrictor
G10	120	0.25	Flow restrictor to outlet valve (center port)
G11	500	0.25	Outlet valve (port 2) to fraction collector
<i>Tubing kit 0.50 mm</i>			
H5	270	0.50	Injection valve pos. 1 to column valve V2 (center port)
H7	550	0.50	Column valve V3 (center port) to top of UV cell
H8	160	0.50	UV cell to conductivity cell
H9	450	0.50	Conductivity cell to flow restrictor
H10	120	0.50	Flow restrictor to outlet valve (center port)
H11	500	0.50	Outlet valve (port 2) to fraction collector
H12	110	0.50	pH flow cell to flow restrictor

¹ G = General tubing
H = High flow tubing
W = Waste tubing
A = Inlet tubing A
B = Inlet tubing B
F = Fraction tubing

5.1.7 Changing tubing kits – ÄKTAexplorer 100

There are three different tubing kits available in ÄKTAexplorer 100:

- Tubing kit 0.75 (G1–G15, W3). Installed from factory at delivery.
- Tubing kit 1.0 (H1–H15, W4). Should be fitted when using low pressure columns at high flow rates.
- Tubing kit 0.5 (L1–L6). Should be fitted when using columns that give peak volumes less than 1 ml. When Tubing kit 0.5 is used, the flow direction valve V7 is bypassed, i.e. reversed flow is not possible, and also the pH flow cell is bypassed.



WARNING! Incorrectly fitted tubing may loosen, causing a jet of liquid to spray out. This is especially dangerous if hazardous chemicals are in use. Connect the tubing by first inserting the tubing fully, then tightening the connector fingertight. PEEK tubing should be tightened a further 1/4 turn using the key supplied. Do not tighten Teflon tubing further as this will damage the end of the tubing.



WARNING! The bend radius of PEEK tubing must never be less than 10 cm (with the exception of heat treated, preformed tubing). A smaller radius decreases the allowed maximum pressure and the tubing may break.



WARNING! The maximum allowed pressure for the tubing in the Tubing kit 1.0 is 3.4 MPa (34 bar, 493 psi). Set a pressure limit in UNICORN that is less than this value. If higher pressures are used, the tubing may break, releasing a jet of liquid.



WARNING! Use ONLY tubings supplied by GE Healthcare to ensure that the pressure specifications of the tubings are fulfilled.

When changing from Tubing kit 0.75 to Tubing kit 1.0 or vice versa, change the following tubing (the Tubing kit 1.0 references are shown in parentheses, H1–H15, W4). Refer to the flow diagram in Section 5.1.4 for their locations in the fluid handling path:

Tubing	Length (mm)	Location
G1 (H1)	330	Pump P-900A (inner) to mixer (left)
G2 (H2)	330	Pump P-900B (outer) to mixer (right)
G3 (H3)	150	Mixer to on-line filter
G4 (H4)	460	On-line filter to valve 1 pos. 7
G5 (H5)	470	Valve 1 pos. 1 to valve 7 pos. 7
G6 (H6)	410	Valve 7 pos. 1 to valve 2 center
G7 (H7)	620	Bypass, valve 2 pos. 1 to valve 3 pos. 1
G8 (H8)	470	Valve 3 center to valve 7 pos. 6
G9 (H9)	180	Valve 7 pos. 3 to valve 7 pos. 4
G10 (H10)	370	Valve 7 pos. 2 to UV cell
G11 (H11)	160	UV cell to conductivity cell
G12 (H12)	450	Conductivity cell to pH cell
G13 (H13)	110	pH cell to restrictor
G14 (H14)	120	Restrictor to valve 4 center port
G15 (H15)	500	Valve 4 pos. 2 to fraction collector
W3 (W4)	-	Valve 4 pos. 1 to waste

Note: Capillaries with other designations than shown in the table above may be included in the tubing kits (e.g. G16/H16/L7). Simply ignore these capillaries and throw away if you like.

Note: In applications where pH measurement is not relevant, for example RPC, the pH flow cell can be replaced with the Union 1/16"female /1/16" female supplied.

The following table lists the tubing to connect when changing from Tubing kit 0.75 to Tubing kit 0.5. Refer to the flow diagram below for their location in the fluid handling path:

5 Reference information
 5.1 System description

Tubing	Length (mm)	Location
L1	270	Valve V1 pos. 1 to valve V2 center
L2	550	Valve V3 center to UV cell
L3	160	UV cell to conductivity cell
L4	450	Conductivity cell to restrictor
L5	120	Restrictor to valve 4 center
L6	500	Valve 4 pos. 2 to fraction collector

Note: Capillaries with other designations than shown in the table above may be included in the tubing kits (e.g. G16/H16/L7). Simply ignore these capillaries and throw away if you like.

Note: Neither the pH flow cell nor the flow direction valve are in the fluid handling path.

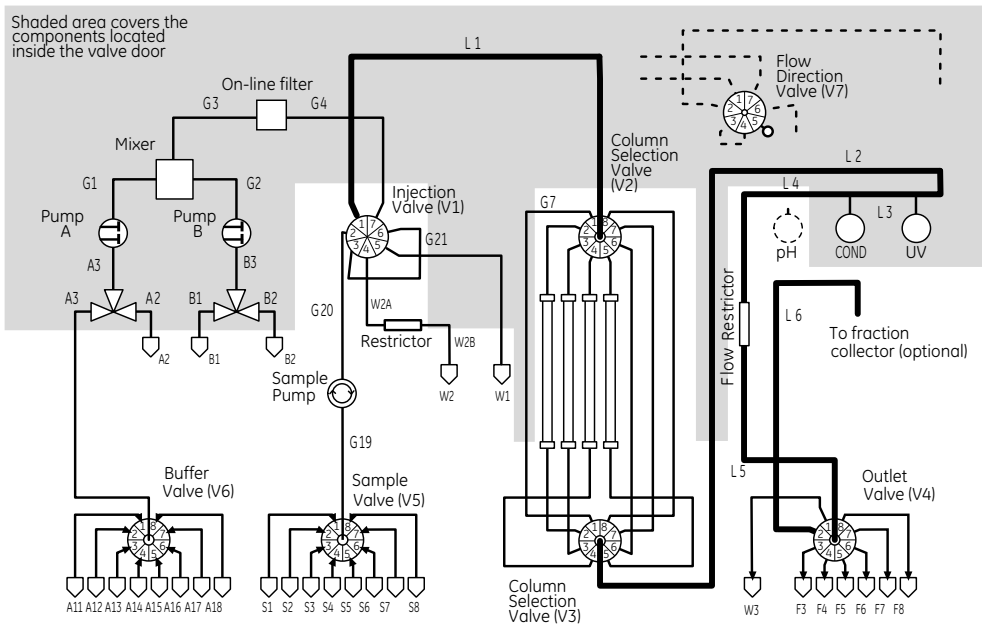

When changing back to Tubing kit 0.75 from Tubing kit 0.5, connect the following tubing. Refer to the flow diagram in Section 5.1.4 for the location in the fluid handling path:

Tubing	Length (mm)	Location
G5	470	Valve 1 pos. 1 to valve 7 pos. 7
G6	410	Valve 7 pos. 1 to valve 2 centre
G8	470	Valve 3 center to valve 7 pos. 6
G9	180	Valve 7 pos. 3 to valve 7 pos. 4
G10	370	Valve 7 pos. 2 to UV cell
G11	160	UV cell to conductivity cell
G12	450	Conductivity cell to pH cell
G13	110	pH cell to restrictor
G14	120	Restrictor to valve 4 center port
G15	500	Valve 4 pos. 2 to fraction collector

5.2 Components description

A complete description of each component can be found in their respective manuals and instructions.

5.2.1 Pump P-900

Pump P-900 is the collective name for a pump family. It is a high performance laboratory pump for use where accurately controlled liquid flow is required. It is a low pulsation pump equipped with 2 pump modules; A and B. This allows for binary gradients with high pressure mixing. A pressure sensor is connected to pump module A (left hand pair of pump heads).

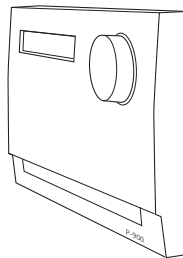

5 Reference information

5.2 Components description

The model installed in ÄKTAexplorer 10 has 10 ml pump heads and is referred to as Pump P-903. P-903 has an operating flow rate range of 0.001–10 ml/min in isocratic mode and in gradient mode, and a pressure range of 0–25 MPa (250 bar, 3625 psi).

The model installed in ÄKTAexplorer 100 has 100 ml pump heads and is referred to as Pump P-901. P-901 has an operating flow rate range of 0.01–100 ml/min in isocratic mode and in gradient mode, and a pressure range of 0–10 MPa (100 bar, 1450 psi).

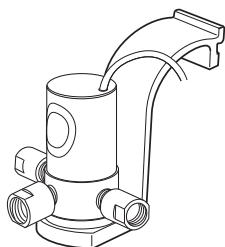

5.2.2 Valve SV-903

Valve SV-903 (Pump switching valve) is a 2-way 3-port valve. It is used with Pump P-900 and is powered and controlled from the pump. The valve may be used as a switching valve for gradient formation and BufferPrep or as a sample application valve for switching between sample and buffer solutions.

5.2.3 Monitor pH/C-900

Monitor pH/C-900 is a combined monitor for accurate, on-line monitoring of pH, conductivity and temperature in a wide range of liquid chromatography applications. Its accurate response coupled with high precision over a wide measuring range makes it ideal for use in all chromatography techniques, from reversed phase with very low conductivity eluents to hydrophobic interaction chromatography in high salt solutions.

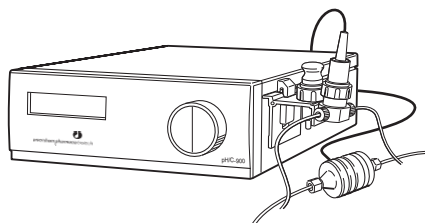

Monitor pH/C-900 consists of a control unit, a flow cell for conductivity and temperature, a flow cell with a holder for the pH electrode and the pH electrode.

5.2.4 Monitor UV-900

Monitor UV-900 is a multi-wavelength UV-Vis monitor that uses advanced fiber optic technology to monitor with high sensitivity at up to three wavelengths simultaneously in the wavelength range 190-700 nm. The use of fiber optics together with a unique flow cell design ensures a high signal-to-noise ratio with a minimal drift and refractive index effects.

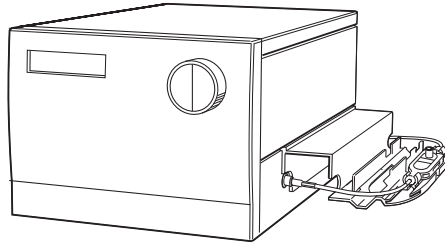

Monitor UV-900 consists of a main unit, optical fibers and a choice of two flow cells.

5.2.5 UV flow cells

The type of flow cell used depends on the sample amount applied and the size of the column.

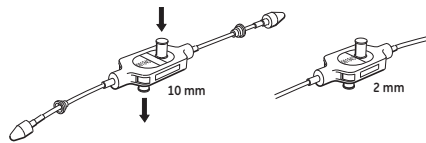

ÄKTAexplorer 10 is delivered with the 10 mm cell fitted. A 2 mm cell (optical path length 2 mm, internal volume 2 μ l) is available as an accessory. If a lower detection sensitivity is desired, due to output signal limitation, the 2 mm flow cell should be used.

ÄKTAexplorer 100 is delivered with the 2 mm cell fitted. A 10 mm cell (optical path length 10 mm, internal volume 8 μ l) is available as an accessory. For higher detection sensitivity, the 10 mm flow cell should be used.

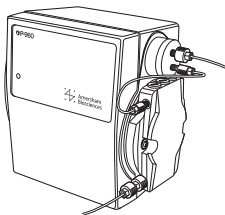

5.2.6 Pump P-960

Pump P-960 is a single-channel laboratory pump for use as a laboratory pump to fill sample loops and Super loops and to inject the sample directly onto the column. The pump is a standard component in all ÄKTAexplorer systems except in ÄKTAexplorer 10 and 10 XT.

The sample is drawn into the pump by three plunger pumps. The flow paths in the pump are equipped with non-return check valves.

A stepper motor assembly performs the pumping action of the chambers. This assembly acts on the chambers in a sequential order, which gives a smooth flow from the pump. The pump produces flow rates up to 50 ml/min and has an operating pressure up to 2.0 MPa.

5 Reference information

5.2 Components description

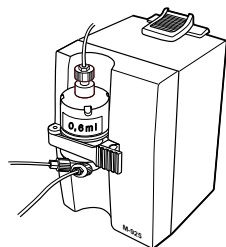

5.2.7 Mixer M-925

Mixer M-925 is a dynamic, dual chamber mixer powered and controlled from Pump P-900. All eluents commonly used in ion exchange, hydrophobic interaction, affinity and reversed phase chromatography can be mixed with a high degree of accuracy and reproducibility. The mixer is positioned directly after Pump P-900 in ÄKTAexplorer.

Mixer M-925 has four interchangeable mixing chambers (0.6, 2, 5, and 12 ml) for optimal mixing in the entire flow rate range of ÄKTAexplorer 10 and ÄKTAexplorer 100.

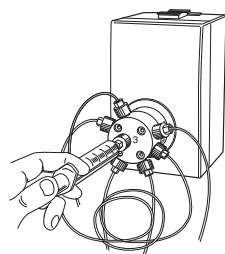

5.2.8 Valve INV-907

Valve INV-907 is a seven port motorized valve. In ÄKTAexplorer 100, there are two of them; one used as a sample injection valve and the other for reversed flow through the column. In ÄKTAexplorer 10, the valve is only used for sample injection.

When used as a sample injection valve, three operating positions make it possible to:

- Load a sample loop without disturbing column equilibration.
- Inject the sample onto the column.
- Wash the sample loop while the column is in operation.
- Wash the pump for quick eluent exchange without disturbing the column.

Sample volumes up to 150 ml can be applied via loops connected to the sample injection valve.

- Using a range of fixed volume loops for applying samples from 100 μ l to 2 ml with accuracy and precision. Partially filling a loop allows sample application of volumes smaller than 100 μ l.
- Using Superloop 10 ml, Superloop 50 ml, and Superloop 150 ml for applying samples in the range 1–10 ml, 1–50 ml, and 1–150 ml respectively. All three are loaded by a syringe.

Larger volumes are applied via the sample pump, Pump P-960, which allows the application of several liters of sample.

The second seven port valve in ÄKTAexplorer 100 is for reversed flow through the column, and is used for column cleaning as well as when reversed elution is preferred.

Reversed flow configurations

DOWN-FLOW, position 1

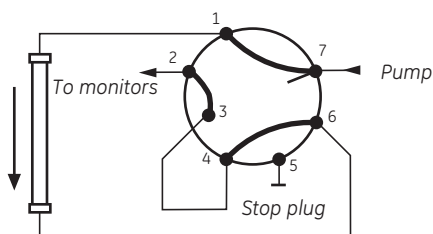

UPWARD-FLOW, position 2

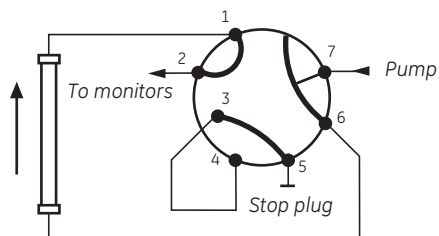

5.2.9 Valves IV-908 and PV-908

For eluent switching, one IV-908 is used in ÄKTAexplorer. It is connected before Pump P-900 and allows switching between 8 different buffers or samples.

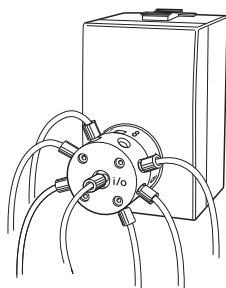

ÄKTAexplorer 10 contains three PV-908 valves. Two of them are used for automatic column switching, which facilitates media scouting. The third is utilized as an outlet valve, connecting the outlet to waste, a fraction collector (optional), collecting up to seven large fractions, or flowthrough.

ÄKTAexplorer 100 contains four PV-908 valves, of which two are used for automatic column switching. One PV-908 can be used for automatic sample application of up to 8 samples. The last one is utilized for collecting up to seven large fractions.

Valve PV-908, with a pressure limit of 25 MPa, and IV-908, with a pressure limit of 2 MPa, are motorized 8-way valves. Compared with PV-908, IV-908 allows higher flow rates at lower back-pressures since it has larger diameter channels and is hence used on the inlet side of the system.



5.2.10 Flow restrictors FR-904 and FR-902

The flow restrictor generates a steady back-pressure to prevent air bubbles being formed after the column in the flow cells. There are two flow restrictors delivered with the system.

FR-904 is set from factory to 0.4 MPa and is mounted in the system at delivery.

FR-902 is set from factory to 0.2 MPa and is used when the pH electrode is mounted in the pH flow cell.



5.2.11 On-line filter

The on-line filter is fitted between the output of Mixer M-925 and position 7 of the injection valve. Arrows on the on-line filter indicates the flow direction. It generates a back-pressure of 0.5 MPa maximum.

The filter is a depth type filter and has a pore size of 2 μm . The filter used in ÄKTAexplorer 10 systems is made of titanium. In ÄKTAexplorer 100 systems, it is made of polypropene.

The filter should be replaced every week. When changing the filter, use a tool if necessary, to unscrew the filter body. When assembling the online filter, tighten the filter body by hand only. Never use a tool.

5.2.12 Fraction collector (optional)

A fraction collector can be used for both small scale and preparative scale purifications with ÄKTAexplorer. A number of racks for different tubes sizes are supplied with the fraction collector.

In ÄKTAexplorer, the fraction collector allows fixed volume fractionation or automatic peak fractionation. The latter function is based on UV peak detection using slope or level sensing, or external trigger (if using AD-900).

Fraction marks and fraction numbers make it easy to identify fractions and peaks.

Fast tube change minimizes spills between tubes. Drop synchronization eliminates sample loss during tube change.

5.3 BufferPrep details

5.3.1 Creating your own recipes

- 1 Select **Edit:BufferPrep Recipes** in the **Method Editor**.
- 2 Click **New** to open the **New Recipe** box.
- 3 Select a buffer substance from the list. If the required buffer substance is not listed, a new buffer substance can be defined, see Section 5.3.2 below. Up to 5 buffering components can be added.
- 4 Set the stock concentration of the buffer.

Buffer concentrations of 2–4 times higher compared to normal preparation should be used. When BufferPrep is used the buffer will be diluted between 2–10 times, dependent on the amount of acid/base that has to be used to reach the desired pH.

It is recommended that the total concentration for all buffer substances selected for the recipe should be between 0.03 M and 0.2 M (typically 0.1 M for ion exchange chromatography).

- 5 Select either **Acid** or **Base** (HCl or NaOH) from the pull-down list and set the inlet concentration (typically 0.1 M).
- 6 Select a salt from the pull-down list. If the required salt is not listed, a new salt can be defined, see Section 5.3.3 below.
- 7 Set the maximum outlet concentration of the salt to 100% B (usually 1.0 M). The maximum outlet salt concentration is half the concentration of the inlet salt stock solution.
- 8 Set the pH range required for the buffer.

Note: To set a useful pH range, the pKa must be known. Click the Buffer substance button and select the buffer component. The pKa values are shown in the list. Typically, a pH range ± 0.5 units around the pKa is useful. For exact ranges, check the buffer tables.

- 9 To add notes about the recipe, click **Notes** and enter the required text in the box displayed. Click **OK** to close the **Recipe Notes** dialog.
- 10 When you have created your recipe, click **Save As**. Give the recipe a name. The recipe is checked and if the pH range selected is not feasible, a warning is displayed giving the error condition and making suggestions for its correction. Correct the recipe and click **Save As** again.

Note: The check does not include whether the buffering capacity is large enough over the entire pH range.

- 11 Click **Close** to close the **BufferPrep Recipes** dialog.

5.3.2 Defining a new buffer substance

Before defining a new buffer substance, make sure that all pKa values for the substance are available. The pKa values entered should be true pKa (i.e. the pKa value at indefinite dilution) as opposed to apparent pKa (i.e. measured at a non-zero concentration). Refer to Section 5.3.5 for information on true and apparent pKa. The pKa values should be given at 25 °C.

- 1 Click **New** in the **BufferPrep Recipes** dialog to open the **New Recipe** dialog. Click the **Buffer substance** button and click **New** in the **Define Buffer Substance** dialog that opens.
- 2 In the **New Component** dialog, enter the name of the new buffer substance. Click **OK**.
- 3 In the **Define Buffer Substance** table, enter the pKa **Value**. Up to 3 values (**pKa1– pKa3**) can be entered for each buffering component. The pKa values must be entered in order of increasing value, starting with the lowest pKa value. When the buffering component has less than three pKa, the other pKa values should be set to zero.
- 4 Enter the dpKa/dT **Value** (the change of pKa dependent on temperature) for each pKa (**dpKa1/dT– dpKa3/dT**). Zero means that the pKa does not change with temperature.
- 5 Enter the **Number of acidic protons** for the buffer substance in the form that is actually weighed in. (Example: For NaH₂PO₄ enter 2, for Na₂HPO₄ enter 1, for Tris enter 0).
- 6 Enter the **Charge of** the completely **deprotonated ion**. This will be a negative value for an acid, 0 for a base. (Example: For NaH₂PO₄ enter -3, for Tris enter 0).
- 7 Click **OK** to add the new buffer substance to the list of available buffers.

5.3.3 Defining a new salt

When defining a new salt make sure that the new salt is inert i.e. a salt with no buffering properties.

- 1 In the **New Recipe** dialog, click **Salt** and click **New** in the **Define Salt** dialog.
- 2 In the **New Component** dialog, enter the name of the new salt. Click **OK**.
- 3 Enter the **Charge of the Anion** (Example: for Cl⁻ enter -1, for SO₄²⁻ enter -2).
- 4 Enter the **Charge of the Cation** (Example: For Na⁺ enter 1, for Mg²⁺ enter 2).
- 5 Click **OK** to add the new salt to the list of available salts.

5.3.4 Correction factors

To obtain higher pH accuracy, the recipe can be fine tuned around a specific pH at the flow rate to be used. When scouting over a broad pH range, fine tuning is less beneficial. Run BufferPrep manually at 0 and 100% B as follows:

- 1 From the **System Control:Manual** menu select **Other**. In the **Other instructions** dialog select **BufferPrep Recipe**. Select the recipe in the **Recipe Name** list. Click **Execute**. Select **Pump** to switch to the **Pump instructions** dialog. Select **Flow**. Select **FlowRate**. Click **Execute**.
- 2 Start a run manually at 0% B. Make sure the buffer valve is set correctly to the required inlet (A11–A18).
- 3 Check the pH reading when stable.
- 4 Change to 100% B by setting the **Gradient** instruction in **Manual:Pump** to 100% B for **Target** and 0 for **Length**. Click **Execute**.
- 5 Check the pH reading when stable at 100%.
- 6 If the reading is acceptable at both 0 and 100% B, the correction factors do not need to be changed.
- 7 If the pH reading is not acceptable it is possible to correct the factors for the recipe. Select **Edit:BufferPrep Recipes** in the Method Editor. Click **New**. In the **New Recipe** dialog click **Correction factors**. Enter the pH deviation at 0 and 100% B. (For example, if the pH set is 7.0 and the actual pH is 7.1 enter 0.1, or if the actual pH is 6.9, enter -0.1).

Note: *Some of the pre-programmed recipes have default correction factors. Add your deviation to these to obtain the correct value. Example: If your pre-set correction factor is -0.2 and your reading at pH 7 is 7.1, enter $-0.2+0.1 = -0.1$.*

- 8 Click **Save As** to save the recipe.

5.3.5 Examples and tips

Buffering capacity

If the buffer capacity of the broad range BufferPrep recipes are too low, there are two alternatives.

- Switch to a recipe with one buffer component with a pKa close to the required pH,
- or
- increase the concentration of all buffers in the broad range recipe. Increase the acid concentration by the same factor as the buffer

concentration. Note that a new recipe has to be created. The ionic strength of the start eluent will also be increased.

Ionic strength

Buffer components with several pKa values will give a higher ionic strength at the start when the pH is set above the second pKa and even higher above the third pKa for acidic buffer components. This may cause problems if you have peaks that elute early in the gradient. To reduce this, use low concentrations or if possible change to buffer components that only have one pKa.

Example

A recipe with 0.1 M Citrate (pKa 3.13, 4.76, and 6.40) will have an ionic strength of approximately 0.22 at pH 6, but only 0.05 M at pH 4. Use instead a 0.03 M solution or use 0.1 M MES at pH 6.

Choice of eluent

To avoid local disturbances in pH caused by buffering ions participating in the ion exchange process, select an eluent with buffering ions of the same charge as the substituent groups on the ion exchanger.

Choose the start buffer pH so that substances to be bound to the ion exchanger are charged, e.g. at least 1 pH unit below the isoelectric point for cation exchangers.

Example

A recipe with Na₂HPO₄ (pKa 2.15, 7.20 and 12.33) will not give accurate pH above approximately pH 7.6 (when titrated with HCl).

Conversion of apparent pKa's to thermodynamic pKa's

Only pKa values at thermodynamic conditions (pKa at infinite dilution) must be entered into BufferPrep. When entering a new buffer substance with only apparent pKa known, a conversion to thermodynamic pKa has to be performed.

The apparent pKa is measured at a non-zero concentration. Find the thermodynamic pKa by taking the apparent pKa and add the value, found in the table below, for the buffer concentration at which the apparent pKa has been measured.

Conc [M]	Base pKa1	Base pKa2	Acid pKa1	Acid pKa2
0.02	-0.05	-0.26	+0.05	+0.26
0.05	-0.07	-0.37	+0.07	+0.37
0.1	-0.09	-0.47	+0.09	+0.47
0.2	-0.12	-0.60	+0.12	+0.60

Example

Bis-Tris has a listed pKa of 6.46 at a concentration of 0.1 M. This is a base with only one pKa. Using the table above we find that 6.37 should give more accurate results ($6.46 - 0.09 = 6.37$).

Zwitter ions

Using zwitter ions in a BufferPrep recipe can be difficult. All zwitter ions have at least two pKa values. Since BufferPrep has to know all pKa values for the buffer component, do not use a zwitter ionic buffer component if the pKa values are not known. The second important issue is to know in which form the component is, i.e. if the molecule contains acidic protons.

Example

These examples can be used as a template for zwitter ions:

Bicine	pKa1 = 1.84 pKa2 = 8.33	dpKa1/dT = value unknown, insert 0 dpKa2/dT = -0.017
--------	----------------------------	---------------------------------------------------------

number of acidic protons = 1
charge of deprotonated ion = -1

HEPES	pKa1 ~ 3 pKa2 = 7.39	dpKa1/dT = value unknown, insert 0 dpKa2/dT = -0.014
-------	-------------------------	---------------------------------------------------------

number of acidic protons = 1
charge of deprotonated ion = -1

Cold room

If the dpKa/dT values are correct, there is no problem using BufferPrep in a cold room. To fine tune the AIEX and CIEX recipes, use the following correction factors:

AIEX at 5 °C	0% B = +0.10	100% B = 0.00
IEX at 5 °C	0% B = 0.00	100% B = -0.40

5 Reference information
 5.3 BufferPrep details

5.3.6 Recipe overview

Data for pre-programmed ALEX recipes

Gradient 0.0–1.0 M NaCl

Buffer	Titrant with	~ pH range	Default correction at		Start conductivity low – high pH
			0%B	100%B	
5.0-9.5 pH ALEX mixture 0.05 M 1-methyl-piperazine 0.05 M Bis-Tris 0.025 M Tris	0.1 M HCl	5.0 – 9.5	0.0	0.0	3.2 – 0.8 mS/cm
6.0-9.0 pH ALEX mixture 0.07 M Bis-Tris 0.05 M Tris	0.1 M HCl	6.0 – 9.0	0.0	0.0	2.5 – 0.4 mS/cm
0.1 M Bis-Tris	0.1 M HCl	6.0 – 7.7	+0.2	0.0	2.2 – 0.4 mS/cm
0.1 M 1-methyl-piperazine	0.1 M HC	5.0 – 5.5 8.6 – 10.3	0.0 -0.1	-0.1 -0.2	2.4 – 0.6 mS/cm 3.3 – 2.8 mS/cm
0.1 M Piperazine	0.1 M HCl	6.0 – 6.7 9.4 – 10.5	-0.1 -0.2	-0.3 -0.4	2.4 – 1.1 mS/cm 3.4 – 2.9 mS/cm
0.1 M Tris	0.1 M HCl	7.5 – 8.5	0.0	-0.2	2.4 – 1.3 mS/cm

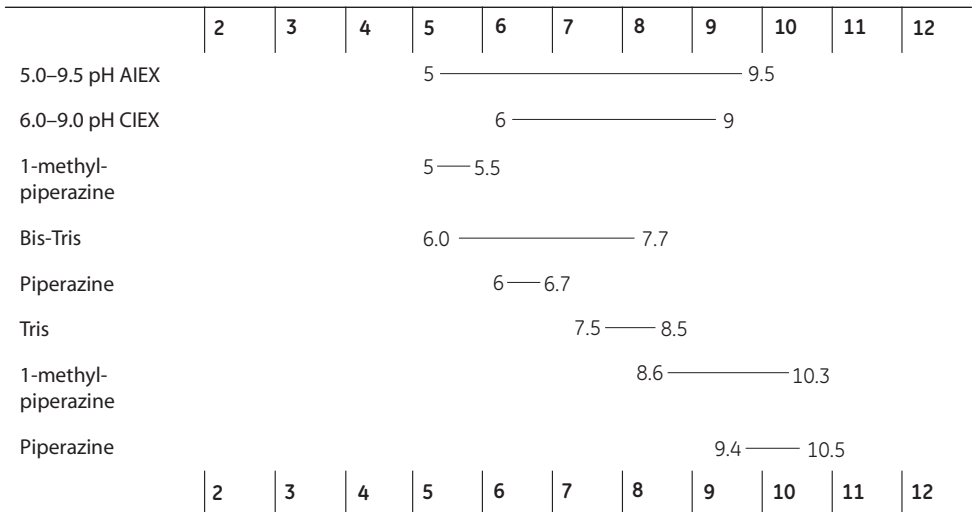

Data for pre-programmed CIEX recipes**Gradient 0.0–1.0 M NaCl**

Buffer	Titrate with	~ pH range	Default correction at		Start conductivity low – high pH
			0%B	100% B	
3.0–7.5 pH CIEX 0.03 M Phosphate Na_2HPO_4 0.03 M Formate Na 0.06 M Acetate Na	0.1 M HCl	3.0 – 7.5	0.0	–0.2	4.2 – 5.7 mS/cm
0.1 M Acetate Na	0.1 M HCl	4.0 – 5.7	0.0	–0.1	3.2 – 3.8 mS/cm
0.1 M Bicine	0.1 M NaOH	7.0 – 9.0	+0.1	0.0	0.4 – 1.7 mS/cm
0.03 M Citrate Na_3	0.1 M HCl	2.5 – 6.2	0.0	–0.2	4.2 – 3.0 mS/cm
0.1 M Formate Na	0.1 M HCl	2.5 – 4.5	0.0	–0.2	4.4 – 3.5 mS/cm
0.1 M HEPES	0.1 M NaOH	6.8 – 8.0	+0.2	+0.3	0.6 – 1.6 mS/cm
0.1 M MES	0.1 M NaOH	5.5 – 6.7	+0.1	+0.1	0.7 – 1.6 mS/cm
0.03 M Phosphate Na_2HPO_4	0.1 M HCl	2.2 – 3.0 6.4 – 7.4	0.0 0.0	–0.3 –0.3	2.4 – 2.6 mS/cm 5.0 – 2.6 mS/cm

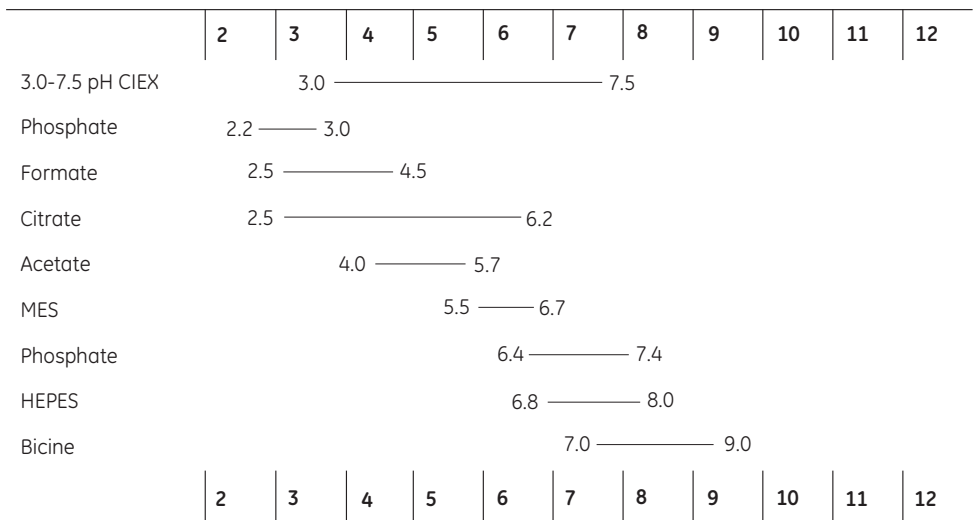

5.4 Technical specifications

For the complete specifications for each component refer to the individual User Manuals and Instructions.

Listed below are the relevant system specifications.

5.4.1 Operating data

Pump P901

Flow rate range	
isocratic mode	0.01–100 ml/min in steps of 10 µl/min
gradient mode	0.01–100 ml/min in steps of 10 µl/min
Pressure range	0–10 MPa (100 bar, 1450 psi)
pH stability range	1–13, 1–14 (< 1 day exposure)
Viscosity	Max. 5 cP
Flow rate accuracy	
0.2–10.0 MPa	±2% or 20 µl/min whichever is greater
Flow rate reproducibility	rsd < 0.5%
> 0.5 ml/min	
Gradient composition accuracy	< ±1% at 0.5–100 ml/min
reproducibility	rsd < 0.25% at 0.5–100 ml/min
Internal volume	< 1800 µl/pump module

Pump P-903

Flow rate range	
isocratic mode	0.001–10 ml/min in steps of 10 µl/min
gradient mode	0.001–10 ml/min in steps of 10 µl/min
double mode	0.001–20 ml/min in steps of 10 µl/min
Pressure range	0–25 MPa (250 bar, 3625 psi)
pH stability range	1–13, 1–14 (< 1 day exposure)
Viscosity	Max. 5 cP

Pump P-903

Flow rate accuracy 0.2–25.0 MPa	±2% or 20 µl/min whichever is greater, with compression compensation activated
Flow rate reproducibility > 0.05 ml/min	rsd < 0.5%
Gradient composition accuracy reproducibility	< ±1% at 0.05–10 ml/min rsd < 0.25% at 0.05–10 ml/min
Internal volume	< 600 µl/pump module

Monitor UV-900

Wavelength range	190–700 nm in step of 1 nm, 3 wavelengths simultaneously
Bandwidth	4 nm
Wavelength accuracy	± 2 nm
Wavelength reproducibility	± 0.01 nm
Wavelength switch time	< 500 ms (one cycle from 214 nm to 254 nm and back to 214)
Linearity ¹	< 2% deviation up to 2 AU at 260 nm with Uracil at pH 2
Noise ^{1,2}	< 6×10 ⁻⁵ AU, with 10 mm cell, H ₂ O at 1 ml/min
Drift ² (at 254 nm)	< 2×10 ⁻⁴ AU/h
Flow cell	
Max. flow rate	100 ml/min
Max. pressure	2 MPa (20 bar, 290 psi)

¹ Specified for 10 mm flow cells² Typical values at room temperature after warm-up

Conductivity Unit

Conductivity range	1 $\mu\text{S}/\text{cm}$ –999.9 mS/cm
Deviation from theoretical conductivity	Max. $\pm 2\%$ of full scale calibration range or $\pm 10 \mu\text{S}/\text{cm}$ whichever is greater in the range 1 $\mu\text{S}/\text{cm}$ –300 mS/cm
Reproducibility	Max. $\pm 1\%$ maximum or $\pm 5 \mu\text{S}/\text{cm}$ whichever is greater in the range 1 $\mu\text{S}/\text{cm}$ –300 mS/cm
Noise	Max. $\pm 0.5\%$ of full scale calibrated range
Flow cell	
Max. flow rate	100 ml/min
Max. pressure	5 MPa (50 bar, 725 psi)

pH unit (if applicable)

pH range	0 to 14 (spec. valid between 2 and 12)
Accuracy	± 0.1 pH unit, temperature compensated within +4 to +40 °C
Long term drift	Max 0.1 pH units deviation/10 h
Flow cell	
Max. flow rate	100 ml/min
Max. pressure	0.5 MPa (5 bar, 72 psi)

Sample Pump P-960

Flow rate range	0.1–50 ml/min in steps of 0.001 ml/min
Pressure range	2.0 MPa (20 bar, 290 psi)

5.4.2 Physical data

Degree of protection	IP 20
Power requirement	100–120/220–240 V ~, 50–60 Hz
Power consumption	600 VA
Fuse specification	T 6.3 AL 250 V
Dimensions, H x W x D	450 x 480 x 610 mm
Weight	66.8 kg
Environment	+4 to +40 °C, 10–95% relative humidity (noncondensing), 84–106 kPa (840–1060 mbar atmospheric pressure).

5.4.3 Hardware requirements

Refer to *UNICORN Administration and Technical Manual*.

5.4.4 Software requirements

Refer to *UNICORN Administration and Technical Manual*.

5.4.5 Network requirements

Refer to *UNICORN Administration and Technical Manual*.

5.4.6 ÄKTAexplorer component materials

The wetted materials of ÄKTAexplorer are listed below:

Simriz									X											
UHMWPE									X											
Ruby/ sapphire	X								X											
Stainl. st.	X								X											
Alum. oxide	X								X											
Gold									X		X									
Quartz		X	X						X											
Titanium alloy	X	X	X						X										X	
PE	X																			
PVDF	X																			
PP											X								X	
Kalrez	X																			
CTFE			X																	
ETFE									X		X									X
FEP																X				
PTFE	X	X	X	X					X		X									
PEEK	X	X		X	X	X	X	X	X	X	X	X	X	X						X
FFKM			X	X																
	Pump P-900	Monitor UV-900	Monitor pH/C-900	Mixer M-925	INV-907	IV/PV-908	SV/FV-903	Pump P-960	On-line filter	Flow restrictor	Tubing	Inlet filters	Unions/ Connectors							

FFKM = perfluororubber
 PEEK = polyetheretherketone
 PTFE = polytetrafluoroethylene
 FEP = perfluoroethylenepropylene copolymer
 ETFE = ethylenetetrafluoroethylene
 CTFE = chlorotrifluoroethylene
 PP = polypropylene
 PVDF = polyvinylidene fluoride
 PE = polyethylene
 UHMWPE = ultra-high molecular weight polyethylene

5.5 Chemical resistance guide and chemical compatibility

The chemical resistance of ÄKTAexplorer to some of the most commonly used chemicals in liquid chromatography is indicated in the table below.

The ratings are based on the following assumptions:

- 1 The synergistic effects of the chemical mixtures have not been taken into account.
- 2 Room temperature and limited over-pressure is assumed.

Note: *Chemical influences are time and pressure dependent. Unless otherwise stated, all concentrations are 100%.*

Chemical	Exposure < 1 day	Exposure up to 2 months	Comments
Acetaldehyde	OK	OK	
Acetic acid, < 5%	OK	OK	
Acetic acid, 70%	OK	OK	
Acetonitrile	OK	OK	FFKM, PP and PE swell
Acetone, 10%	OK	Avoid	PVDF is affected by long term use
Ammonia, 30%	OK	OK	Silicone is affected by long-term use
Ammonium chloride	OK	OK	
Ammonium bicarbonate	OK	OK	
Ammonium nitrate	OK	OK	
Ammonium sulphate	OK	OK	
1-Butanol	OK	OK	
2-Butanol	OK	OK	
Citric acid	OK	OK	
Chloroform	OK	Avoid	Kalrez, CTFE, PP and PE are affected by long term use
Cyclohexane	OK	OK	
Detergents	OK	OK	

5 Reference information

5.5 Chemical resistance guide and chemical compatibility

Chemical	Exposure < 1 day	Exposure up to 2 months	Comments
Dimethyl sulphoxide	Avoid	Avoid	PVDF is affected by long term use
1, 4-Dioxane	Avoid	Avoid	ETFE, PP, PE and PVDF are affected by long term use
Ethanol	OK	OK	
Ethyl acetate	OK	Avoid	Silicone not resistant. Pressure limit for PEEK decreases.
Chemical	Exposure	Exposure	Comments < 1 day up to 2 months
Ethylene glycol	OK	OK	
Formic acid	OK	OK	Silicone not resistant
Glycerol	OK	OK	
Guanidinium hydrochloride	OK	OK	
Hexane	OK	Avoid	Silicone not resistant. Pressure limit for PEEK decreases.
Hydrochloric acid, 0.1 M	OK	OK	Silicone not resistant
Hydrochloric acid, > 0.1 M	OK	Avoid	Silicone not resistant. Titanium is affected by long term use
Isopropanol	OK	OK	
Methanol	OK	OK	
Nitric acid, diluted	OK	Avoid	Silicone not resistant
Nitric acid, 30%	Avoid	Avoid	Elgiloy is affected by long term use
Phosphoric acid, 10%	OK	Avoid	Titanium, aluminium oxide and glass are affected by long term use
Potassium carbonate	OK	OK	

Chemical	Exposure < 1 day	Exposure up to 2 months	Comments
Potassium chloride	OK	OK	
Pyridine	Avoid	Avoid	ETFE, PP and PE not resistant
Sodium acetate	OK	OK	
Sodium bicarbonate	OK	OK	
Sodium bisulphate	OK	OK	
Sodium borate	OK	OK	
Sodium carbonate	OK	OK	
Sodium chloride	OK	OK	
Sodium hydroxide, 1-2 M	OK	Avoid	PVDF and borosilicate glass are affected by long term use
Sodium sulphate	OK	OK	
Sulphuric acid, diluted	OK	Avoid	PEEK and titanium are affected by long term use
Sulphuric acid, medium concentration	Avoid	Avoid	
Tetrachloroethylene	Avoid	Avoid	Silicone, PP and PE are not resistant
Tetrahydrofuran	Avoid	Avoid	ETFE, CTFE, PP and PE are not resistant
Toluene	OK	Avoid	Pressure limit for PEEK decreases
Trichloroacetic acid, 1%	OK	OK	
Trifluoroacetic acid, 1%	OK	OK	
Urea	OK	OK	
o-Xylene p-Xylene	OK	Avoid	PP and PE are affected by long term use

5 Reference information

5.6 Accessories, spare parts and consumables

5.6 Accessories, spare parts and consumables

Pump P-901	Quantity per Pack	Code No.
Pump P-901	1	18-1108-56
Seal kit, 100 ml, including 4 piston seals 4 rinse membranes	1	18-1113-12
Piston kit, 100 ml	1	18-1112-13
Inlet tubing kit, 100 ml	1	18-1114-40
Pump head capillaries, 100 ml (capillaries (2) for one pump module)	1	18-1117-52
Rinsing/draining housing	1	18-1112-03
Pump head, 100 ml complete	1	18-1128-48
Pump P-903	Quantity per Pack	Code No.
Pump P-903	1	18-3100-00
Seal kit, 10 ml, including 2 piston seals 2 rinse membranes	1	18-1120-77
Piston kit, 10 ml	1	18-1120-75
Inlet tubing kit, 10 ml	1	18-1119-26
Pump head capillaries, 10 ml	1	18-1120-81
Rinsing/draining housing, 10 ml	1	18-1120-76
Pump head, 10 ml complete	1	18-1128-47
Pumps P-901 and P-903	Quantity per Pack	Code No.
Tubing kit for rinsing system	1	18-1113-32
Purge kit	2	18-1124-53
Purge valve	1	18-1128-87

Pumps P-901 and P-903	Quantity per Pack	Code No.
O-ring for purge valve	10	19-0036-01
Check valve kit including: 1 Inlet check valve 1 Outlet check valve	1	18-1128-66
Monitor pH/C-900	Quantity per Pack	Code No.
Monitor pH/C-900 complete but without pH electrode	1	18-1107-76
pH electrode, round tip, including flow cell and holder	1	18-1134-84
pH electrode, round tip	1	18-1111-26
pH flow cell, round tip, including dummy electrode	1	18-1112-92
Dummy electrode, round tip	1	18-1111-03
Conductivity flow cell	1	18-1111-05
Monitor UV-900	Quantity per Pack	Code No.
Monitor UV-900 complete but without flow cells	1	18-1108-35
Flow cell UV-900, 2 mm	1	18-1111-10
Flow cell UV-900, 10 mm	1	18-1111-11
Flow detachment tool	1	18-1111-16

5 Reference information











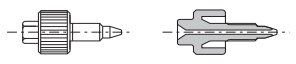
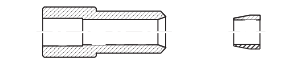

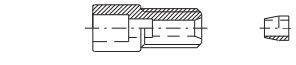

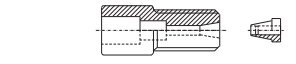
5.6 Accessories, spare parts and consumables

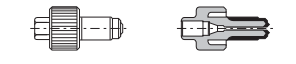
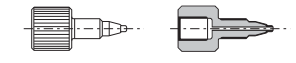
Mixer M-925	Quantity per Pack	Code No.
Mixer M-925 including one UniNet cable	1	18-1118-89
Mixing chambers:		
0.6 ml	1	18-1118-90
2 ml	1	18-1118-91
5 ml	1	18-1118-92
12 ml	1	18-1118-93
Pump P-960		
Pump P-960	1	18-6727-00
Valves IV-908, PV-908		
Valve IV-908 including one UniNet cable	1	18-1108-42
Valve PV-908 including one UniNet cable	1	18-1108-41
Valve kit, including channel plate and distribution plate		
IV-908	1	18-1109-07
PV-908	1	18-1109-06
Number plates 0–9	1	18-1109-09
Mounting bracket	1	18-1109-11
Valve INV-907		
Valve INV-907 including one UniNet cable (fill port, needle and syringe holder are not included)	1	18-1108-40
Injection kit INV-907 including fill port, needle and syringe holder	1	18-1110-89
Valve kit INV-907 including channel plate and distribution plate	1	18-1109-05
Sample loops		
100 µl	1	18-1113-98
500 µl	1	18-1113-99
1 ml	1	18-1114-01
2 ml	1	18-1114-02

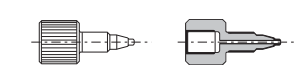
Mixer M-925	Quantity per Pack	Code No.
Mounting bracket	1	18-1109-11
Valve SV-903		
Valve SV-903, including mounting bracket	1	18-1114-49
Cables		
UniNet, 0.18 m	1	18-1109-72
UniNet, 0.3 m	1	18-1109-73
UniNet, 0.7 m	1	18-1109-74
UniNet, 1.5 m	1	18-1117-75
UniNet, 3.0 m	1	18-1109-75
UniNet, 15.0 m	1	18-1117-74
Mains cable, 120 V	1	19-2447-01
Mains cable, 240 V	1	19-2448-01
Signal cable, 6 pin mini DIN-open	1	18-1110-64

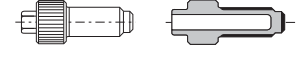
5 Reference information

5.6 Accessories, spare parts and consumables

	Item:Connectors and unions	Quantity per Pack	Code No.
	Fingertight connector, 1/16" for 1/16" o.d. tubing, PEEK	10	18-1112-55
	Tubing connector for 3/16" o.d. tubing, PEEK	10	18-1112-49
	Ferrules for 3/16" o.d.tubing, PEEK	10	18-1112-48
	Tubing connector for 1/8" o.d. tubing, PEEK	10	18-1121-17
	Ferrules for 1/8" o.d.tubing, PEEK	10	18-1121-18
	Tubing connector for 1/16" o.d. tubing, PEEK	10	18-1127-07
	Ferrules for 1/16" o.d.tubing, PEEK	10	18-1127-06
	Union 1/16" female/M6 male, PEEK	6	18-1112-57
	Union M6 female/1/16" male, PEEK	8	18-1112-58
	Union Luer female/1/16" male, PEEK	2	18-1112-51
	Union 5/16"-32 female/HPLC male, PEEK	8	18-1142-08
	Stop plug, 1/16", PEEK	5	18-1112-52
	Stop plug, 5/16", PEEK	5	18-1112-50
	Union, 1/16" female/1/16" female, titanium	1	18-3855-01
	Union Luer male/M6 female	1	18-1027-12
	Tubing connector/M6 male	1	18-1017-98

Inlet filter	Quantity per Pack	Code No.
Inlet filter set	5	11-0004-14
Filter holder kit	1	11-0004-07
Screw lid GL45 kit	1	11-0004-10
Inlet filter kit, 1 filter, 1 net, 1 lid (GL45)	1	18-1113-15

5 Reference information

5.6 Accessories, spare parts and consumables

Tubing	Quantity per Pack	Code No.
PEEK tubing, i.d. 0.25 mm, o.d. 1/16"	2 m	18-1120-95
PEEK tubing, i.d. 0.50 mm, o.d. 1/16"	2 m	18-1113-68
PEEK tubing, i.d. 0.75 mm, o.d. 1/16"	2 m	18-1112-53
PEEK tubing, i.d. 1.0 mm, o.d. 1/16"	2 m	18-1115-83
Tefzel tubing, i.d. 0.75 mm, o.d. 1/16"	2 m	18-1119-74
Tefzel tubing, i.d. 1.0 mm, o.d. 1/16"	3 m	18-1142-38
Teflon tubing, i.d. 1.6 mm, o.d. 1/8"	3 m	18-1121-16
Teflon tubing, i.d. 2.9 mm, o.d. 3/16"	3 m	18-1112-47
Tubing Kit ¹ , i.d. 0.25 mm, PEEK	1	18-1122-12
Tubing Kit ¹ , i.d. 0.50 mm, PEEK	1	18-1123-21
Tubing Kit ² , i.d. 0.5 mm, o.d. 1/16"	1	18-1121-64
Tubing Kit ² , i.d. 0.75 mm, o.d. 1/16"	1	18-1122-14
Tubing Kit ² , i.d. 1.0 mm, o.d. 1/16"	1	18-1121-65
Tubing kit, complete with inlet tubing ÄKTAexplorer 10S	1	18-1126-29
Tubing kit, complete with inlet tubing ÄKTAexplorer 100	1	18-1126-30
Sample Tubing Kit. 1.0 mm. including (2),i.d. 1.0 mm length 1250 mm and two connectors and two ferrules	1	18-1115-77

¹Contains tubing as listed in table in section 5.1.6 Changing tubing kits – ÄKTAexplorer 10.

²Contains tubing as listed in table in section 5.1.7 Changing tubing kits – ÄKTAexplorer 100.

Accessories	Quantity per Pack	Code No.
On-line filter, (10 ml systems)	1	18-1118-01
On-line filter kit, (10 ml systems) 2 filters	2	18-1120-94
On-line filter, (100 ml systems)	1	18-1112-44
On-line filter kit, (100 ml systems) 10 filters and 2 nets	10	18-1027-11
On-line filters, (100 ml systems) 25 filters	25	18-1130-23
Short column holder	1	18-1113-17
Long column holder	1	18-1126-32
Small column clamp	1	18-1149-98
Tubing cutter	1	18-1112-46
Flow restrictor, FR-904, 0.4 MPa	1	18-1119-63
Flow restrictor, FR-902, 0.2 MPa	1	18-1121-35
Lab rod holder	1	18-1113-19
Sample holder, SH-900, including 1 Sample tray, 2 Sample tube holders, 1 Sample tubing holder, and 1 Mounting plate	1	18-1110-78
User Manuals		Code No.
ÄKTAexplorer User Manuals and Instructions (Box containing User Manuals/Instructions for all components in ÄKTAexplorer)		18-1141-01
ÄKTAexplorer Optional Configurations User manual		18-1174-43
ÄKTAexplorer Installation Guide		18-1139-59
Making your first runs		18-1140-78
UNICORN 5.10 Manual Kit		28-4010-25

5 Reference information

5.6 Accessories, spare parts and consumables

User Manuals	Code No.
ÄKTAexplorer System Manual	18-1140-45
ÄKTAexplorer Method Handbook	18-1124-23
Pump P-900 User Manual	18-1120-04
Monitor UV-900 User Manual	18-1120-05
Monitor pH/C-900 User Manual	18-1120-06
Short Instruction Pump P-900	18-1120-08
Short Instruction Monitor UV-900	18-1120-09
Short Instruction Monitor pH/C-900	18-1120-10

Index

A

accessories 128
automated filling of sample loops 43

B

before a run 53
buffer stock 48
buffer valve 13, 96, 111, 130
BufferPrep 19
 creating your own recipes 113
 details 113
 examples and tips 115
 fine tuning 51
 in cold room 117
 mixing gradients 46
 pH scouting 49
 preparing the system for 50
 recipe overview 118
 recipes 113
 strategy for using 49
 troubleshooting 75, 89
 what is BufferPrep? 47

C

cables
 mains 93
calibration 54
changing tubing kit
 ÄKTAexplorer 10 101
 ÄKTAexplorer 100 104
chemical resistance guide 125
cleaning the system 71
cold room
 operation 58
 preparation 58
 run 58
collecting fractions 52
 fixed volume fractionation 52
 peak fractionation 52
 with outlet valve 53
column 96
column holder 11, 92, 96
column selection valve 11, 13, 92, 96
columns and tubing 19, 20
complete filling of sample loops 42
completion of run 57
component
 locations 92
 materials 124
components 107

 description 107
 FR-904 and FR-902 112
 fraction collector 112
 front panel displays 56
 location 11
 mixer M-925 110
 monitor pH/C-900 108
 monitor UV-900 108
 on-line filter 112
 Pump P-900 107
 pump P-960 109
 UV flow cells 109
 valve INV-907 110
 Valve SV-903 108
 Valves IV-908 and PV-908 110
 valves IV-908 and PV-908 111
conductivity 108
 cell 13, 108, 121, 129
 curve 78
connections
 electrical 93
 mains 93
consumables 128

D

data
 operation 120
 physical 123
defining a new salt 114
description of system 91
displays 55

E

electrical connections 93
emptying the sample loop 46
end of a run 57

F

faults and actions 75
feedback tuning 59
filling sample partially 41
filter on-line 112
fixed peak fractionation 52
fixed volume fractionation 52
flow direction valve 13
flow path 55
 ÄKTAexplorer 10 95
 ÄKTAexplorer 100 99
flow rate range 120
flow restrictor 11, 96

- flow restrictors
 - description 112
 - reference information 135
- flow schematics
 - ÄKTAexplorer 10 97
 - ÄKTAexplorer 100 100
- flowthrough fractionation 52
- fluid handling path 95
 - ÄKTAexplorer 10 95
 - ÄKTAexplorer 100 99
- fraction collection 52
 - with outlet valve 53
- fraction collector 112
- fuse 93, 123

G

- gradients 46

H

- hardware requirements 123

I

- injection valve 11, 13, 96
 - kit 130
 - preparation 40
 - valve INV-907 110
- inlet tubing 13

L

- lifting the system 73
- location of modules and components 11
- locking the selection dials 57

M

- mains connection 93
- mains switch 13
- maintenance 65
 - periodic 65
 - system cleaning 71
- manual changes 57
- manual filling of sample loops 40
- materials
 - ÄKTAexplorer components 124
 - wetted 124
- mixer 13, 96
 - M-925 110
 - maintenance 70
 - troubleshooting 86
- mixing
 - chamber volume 47
 - gradients 46
- monitor 13
 - pH/C-900 108
 - pH/C-900 troubleshooting 83
 - UV-900 108

- UV-900 troubleshooting 82
- moving the system 73

N

- network requirements 123

O

- on-line filter 112
- operating data 120
- outlet tubing 13
- outlet valve 11, 13, 96
 - fractionation 53
 - wash 72

P

- partial filling 41
- peak fractionation 52
- periodic maintenance 65
- pH curve
 - troubleshooting 79
- pH electrode 11
 - calibration 55
 - holder 108
 - maintenance 67
 - storage 58
 - usage 54
- pH scouting 49
- pH unit 122
- physical data 123
- pKa

- display value 113
- true or apparent 114

power

- consumption 123
- requirements 123

preparation

- automated filling 43
- before starting method 54
- cold room operation 58
- injection valve 40
- sample application 43

pressure curve

- troubleshooting 82

pump P-900

- troubleshooting 83

pump P-960 109

- troubleshooting 87

purge pump 54

- purge tubing 13

R

- recipes
 - BufferPrep 113
 - creating 52

- fine tuning 51
- requirements
 - hardware 123
 - network 123
 - power 123
 - software 123
- run
 - cold room 58
 - completion 57

S

- safety information 14
- salt defining 114
- salt stock 48
- sample application
 - overview 38
 - techniques 39
- sample loops
 - automated filling 43
 - emptying 42, 46
 - manual filling 40
 - reference information 130
 - sizes and numbers 40
 - volume 39
- sample pump 13, 122
- sample tray 11, 135
- sample tube holder 11
- sample tubing holder 11
- sample valve 13
- sample volume 41
- software requirements 123
- spare parts 128
- specifications 120
- standard tubing 102
- superloop 110
- switch valve 13
- system description 91

T

- technical specifications 120
- troubleshooting 75
 - BufferPrep 89
 - conductivity curve 78
 - mixer 86
 - monitor pH/C-900 83
 - pH curve 79
 - pressure curve 82
 - pump P-900 83
 - pump P-960 87
 - UV curve 76
 - UV-900 82
 - valve IV-908, PV-908, INV-907 88
 - valve SV-903 87
- tubing holder 96

- tubing kit
 - 0.25 mm 103
 - 0.50 mm 103
 - changing ÄKTAexplorer 10 101
 - changing ÄKTAexplorer 100 104
 - overview ÄKTAexplorer 10 102
 - overview ÄKTAexplorer 100 100
 - recommendation ÄKTAexplorer 10 21
 - recommendation ÄKTAexplorer 100 29
- tuning feedback 59

U

- UniNet-1 94
- Uninet-1 93
- UniNet-2 95
- Uninet-2 94
- UV cell 13
- UV curve
 - troubleshooting 76
- UV flow cells 109

V

- valve INV-907 110
 - troubleshooting 88
- valve IV-908
 - troubleshooting 88
- valve PB-908
 - troubleshooting 88
- valve SV-903
 - troubleshooting 87
- valves
 - IV-908 111
 - PV-908 111
- view run progress 55
- volume fractionation 52
- volume of mixing chamber 47

W

- wetted materials 124

For contact information for your local office,
please visit
www.gelifesciences.com/contact

GE Healthcare Bio-Sciences AB
Björkgatan 30
751 84 Uppsala
Sweden

www.gelifesciences.com

GE, imagination at work and GE monogram are trademarks of General Electric Company.

Drop Design, ÄKTA, ÄKTAexplorer, UNICORN, Superloop, Mini Q, Mini S, Mono S, Mono, GSTPrep, GSTrap, HiTrap, HiPrep, HiLoad, RESOURCE, SOURCE, Sephacryl, Superdex, and Sepharose are trademarks of GE Healthcare companies.

UNICORN: Any use of this software is subject to GE Healthcare Standard Software End-User License Agreement for Life Sciences Software Products.

All third party trademarks are the property of their respective owners.

© 2000-2008 General Electric Company—All rights reserved.
First published Dec. 2000

All goods and services are sold subject to the terms and conditions of sale of the company within GE Healthcare which supplies them. A copy of these terms and conditions is available on request. Contact your local GE Healthcare representative for the most current information.

GE Healthcare UK Ltd
Amersham Place,
Little Chalfont,
Buckinghamshire, HP7 9NA,
UK

GE Healthcare Bio-Sciences Corp
800 Centennial Avenue,
P.O. Box 1327, Piscataway,
NJ 08855-1327,
USA

GE Healthcare Europe GmbH
Munzinger Strasse 5,
D-79111 Freiburg,
Germany

GE Healthcare Bio-Sciences KK
Sanken Bldg. 3-25-1,
Hyakunincho, Shinjuku-ku,
Tokyo 169-0073,
Japan



imagination at work