

**JAWAHARLAL NEHRU TECHNOLOGICAL UNIVERSITY  
HYDERABAD**

**I Year B.Tech.**

**L T/P/D C**

**2 1/-/ 4**

**ENGINEERING PHYSICS**

**UNIT-I**

**1. Bonding in Solids:** Ionic Bond, Covalent Bond, Metallic Bond, Hydrogen Bond, Vander-Waal's Bond, Calculation of Cohesive Energy.

**2. Crystallography and Crystal Structures:** Space Lattice, Unit Cell, Lattice Parameters, Crystal Systems, Bravais Lattices, Miller Indices, Crystal Planes and Directions, Inter Planar Spacing of Orthogonal Crystal Systems, Atomic Radius, Coordination Number and Packing Factor of SC, BCC, FCC, Diamond and hcp Structures, Structures of NaCl, ZnS, CsCl.

**UNIT-II**

**3. X-ray Diffraction:** Basic Principles, Bragg's Law, Laue Method, Powder Method, Applications of X-ray Diffraction.

**4. Defects in Crystals:** Point Defects: Vacancies, Substitutional, Interstitial, Frenkel and Schottky Defects; Qualitative treatment of line (Edge and Screw Dislocations) Defects, Burger's Vector, Surface Defects and Volume Defects.

**UNIT-III**

**5. Elements of Statistical Mechanics:** Maxwell-Boltzman, Bose-Einstein and Fermi-Dirac Statistics (Qualitative Treatment), Photon gas, Wein's Law, Rayleigh-Jeans law, Planck's Law of Black Body Radiation, Concept of Electron Gas, Fermi Energy, Density of States.

**6. Principles of Quantum Mechanics:** Waves and Particles, de Broglie Hypothesis, Matter Waves, Davisson and Germer's Experiment, G. P. Thomson Experiment, Heisenberg's Uncertainty Principle, Schrödinger's Time Independent Wave Equation - Physical Significance of the Wave Function - Particle in One Dimensional Potential Box.

**UNIT-IV**

**7. Band Theory of Solids:** Electron in a periodic Potential, Bloch Theorem, Kronig-Penny Model (Qualitative Treatment), Origin of Energy Band Formation in Solids, Classification of Materials into Conductors, Semi Conductors & Insulators, Concept of Effective Mass of an Electron and Hole.

**UNIT-V**

**8. Semiconductor Physics:** Fermi Level in Intrinsic and Extrinsic Semiconductors, Intrinsic Semiconductors and Carrier Concentration, Extrinsic Semiconductors and Carrier Concentration, Equation of Continuity, Direct & Indirect Band Gap Semiconductors, Hall Effect.

**9. Physics of Semiconductor Devices:** Formation of PN Junction, Open Circuit PN Junction, Energy Diagram of PN Diode, I-V Characteristics of PN Junction, PN Diode as a Rectifier (Forward and Reverse Bias), Diode Equation, LED, LCD and Photo Diodes.

**UNIT-VI**

**10. Dielectric Properties:** Electric Dipole, Dipole Moment, Dielectric Constant, Polarizability, Electric Susceptibility, Displacement Vector, Electronic, Ionic and Orientation Polarizations and Calculation of Polarizabilities - Internal Fields in Solids, Clausius - Mossotti Equation, Piezo-electricity, Pyro-electricity and Ferro- electricity.

**11. Magnetic Properties:** Permeability, Field Intensity, Magnetic Field Induction, Magnetization, Magnetic Susceptibility, Origin of Magnetic Moment, Bohr Magneton, Classification of Dia, Para and Ferro Magnetic Materials on the basis of Magnetic Moment, Domain Theory of Ferro Magnetism on the basis of Hysteresis Curve, Soft and Hard Magnetic Materials, Properties of Anti-Ferro and Ferri Magnetic Materials, Ferrites and their Applications, Concept of Perfect Diamagnetism, Meissner Effect, Magnetic Levitation, Applications of Superconductors.

**UNIT-VII**

**12. Lasers:** Characteristics of Lasers, Spontaneous and Stimulated Emission of Radiation, Meta-stable State, Population Inversion, Lasing Action, Einstein's Coefficients and Relation between them, Ruby Laser, Helium-Neon Laser, Carbon Dioxide Laser, Semiconductor Diode Laser, Applications of Lasers.

**13. Fiber Optics:** Principle of Optical Fiber, Acceptance Angle and Acceptance Cone, Numerical Aperture, Types of Optical Fibers and Refractive Index Profiles, Attenuation in Optical Fibers, Application of Optical Fibers.

**UNIT-VIII**

**14. Acoustics of Buildings & Acoustic Quieting:** Basic Requirement of Acoustically Good Hall, Reverberation and Time of Reverberation, Sabine's Formula for Reverberation Time (Qualitative Treatment), Measurement of Absorption Coefficient of a Material, Factors Affecting The Architectural Acoustics and their Remedies. Acoustic Quieting: Aspects of Acoustic Quieting, Methods of Quieting, Quieting for Specific Observers, Mufflers, Sound-proofing.

**15. Nanotechnology:** Origin of Nanotechnology, Nano Scale, Surface to Volume Ratio, Quantum Confinement, Bottom-up Fabrication: Sol-gel, Precipitation, Combustion Methods; Top-down Fabrication: Chemical Vapour Deposition, Physical Vapour Deposition, Pulsed Laser Vapour Deposition Methods, Characterization (XRD & TEM) and Applications.

**TEXT BOOKS:**

1. Applied Physics – P.K.Palanisamy (SciTech Publications (India) Pvt. Ltd., Fifth Print 2008).
2. Applied Physics – S.O. Pillai & Sivakami (New Age International (P) Ltd., Second Edition 2008).
3. Applied Physics – T. Bhima Shankaram & G. Prasad (B.S. Publications, Third Edition 2008).

**REFERENCES:**

1. Solid State Physics – M. Armugam (Anuradha Publications).
2. Modern Physics – R. Murugesan & K. Siva Prasath – S. Chand & Co. (for Statistical Mechanics).
3. A Text Book of Engg Physics – M. N. Avadhanulu & P. G. Khsirsagar– S. Chand & Co. (for acoustics).
4. Modern Physics by K. Vijaya Kumar, S. Chandralingam: S. Chand & Co.Ltd
5. Nanotechnology – M.Ratner & D. Ratner (Pearson Ed.).
6. Introduction to Solid State Physics – C. Kittel (Wiley Eastern).
7. Solid State Physics – A.J. Dekker (Macmillan).
8. Applied Physics – Mani Naidu Pearson Education

# PHYSICS

## LIST OF CONTENTS

S. No	Name of the Topic	Page No.
1	BONDING IN SOLIDS	
2	CRYSTALLOGRAPHY AND CRYSTAL STRUCTURES	
3	X – RAY DIFFRACTION	
4	DEFECTS IN CRYSTALS	
5	ELEMENTS OF STATISTICAL MECHANICS	
6	PRINCIPLES OF QUANTUM MECHANICS	
7	BAND THEORY OF SOLIDS	
8	SEMICONDUCTOR PHYSICS	
9	PHYSICS OF SEMICONDUCTOR DEVICES	
10	DIELECTRIC PROPERTIES	
11	MAGNETIC PROPERTIES	
12	LASERS	
13	FIBER OPTICS	
14	ACOUSTICS OF BUILDINGS & ACOUSTIC QUIETING	
15	NANOTECHNOLOGY	

# APPLIED PHYSICS

## UNIT-I

### 1. BONDING IN SOLIDS

#### INTRODUCTION

In the gaseous state of matter, individual atoms or molecules can move freely in space with a velocity determined by the temperature. But in solid state, the constituent atoms or molecules that build the solid are confined to a localized region. The principle region between the two states is bonding. In gases, the atoms or molecules are free whereas in solids they are bound in a particular form because of which, they possess certain physical properties such as elasticity, electrical and optical properties.

#### BONDING

Bonding is the physical state of existence of two or more atoms together in a bound form. The supply of external energy is required to get back the bonded atoms to the Free State as energy is needed to break the bonds. This energy is called dissociation (binding) or cohesive energy.

Bonding occurs between similar or dissimilar atoms, when an electrostatic interaction between them produces a resultant state whose energy is lesser than the sum of the energies possessed by individual atoms when they are free.

#### TYPES OF BONDING IN SOLIDS

Bonds in solids are classified basically into two groups namely primary and secondary bonds. Primary bonds are inter atomic bonds i.e. bonding between the atoms and secondary bonds are intermolecular bonds i.e. between the molecules.

##### ***Primary bonds***

The primary bonds are interatomic bonds. In this bonding interaction occurs only through the electrons in the outermost orbit, i.e. the valence electrons. These are further classified into three types

- Ionic bonding
- Covalent bonding
- Metallic bonding

### 1. Ionic Bonding :

Ionic bonding results due to transfer of one or more electrons from an electropositive element to an electronegative element. The two types of atoms involved in the bonding are of dissimilar type.

#### Example:

In NaCl crystal, Na atom has only one electron in outer most shell and a Cl atom needs one more electron to attain inert gas configuration. During the formation of NaCl molecule, one electron from the Na atom is transferred to the Cl atom resulting which, both Na and Cl ions attain filled- shell configuration.

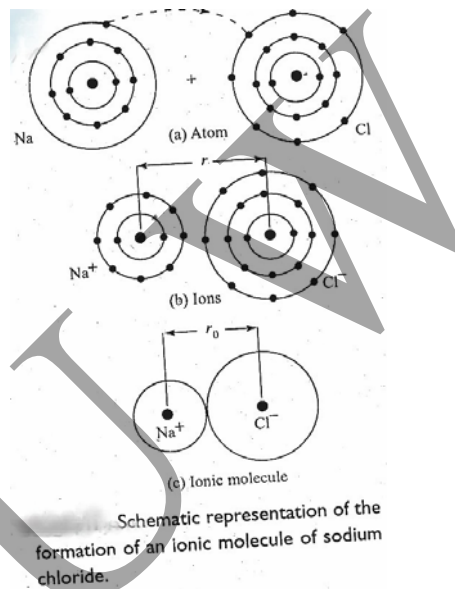
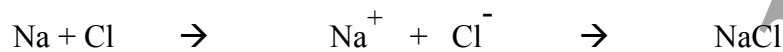

A strong electrostatic attraction is set up that bond the  $\text{Na}^+$  cation and the  $\text{Cl}^-$  anion into a very stable molecule NaCl at the equilibrium spacing.

Since Cl exist as molecules, the chemical reaction must be written as

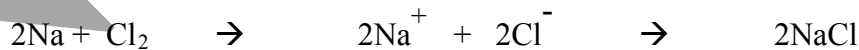

Other examples of ionic crystals are

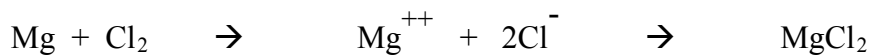
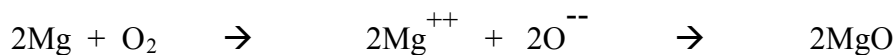

#### Properties:

1. As the ionic bonds are strong, the materials are hard and possess high melting and boiling points.
2. They are good ionic conductors, but poor conductors of both heat and electricity
3. They are transparent over wide range of electromagnetic spectrum
4. They are brittle. They possess neither ductility (ability to be made into sheets) nor malleability (ability to be made into wires).
5. They are soluble in polar liquids such as water but not in non-polar liquids such as ether.

## 2. Covalent Bonding

Covalent bond is formed by sharing of electrons between two atoms to form molecule.

Example: Covalent bonding is found in the  $H_2$  molecule. Here the outer shell of each atom possesses 1 electron. Each H atom would like to gain an electron, and thus form a stable configuration. This can be done by sharing 2 electrons between pairs of H atoms, thereby producing stable diatomic molecules.

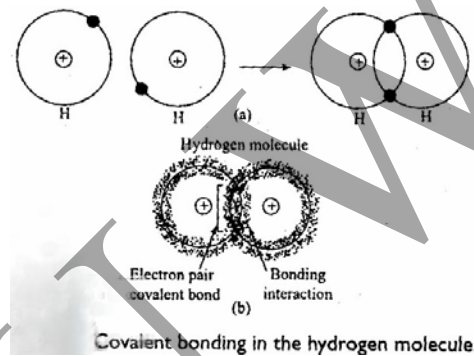

Thus covalent bonding is also known as shared electron pair bonding.

### Properties:

1. Covalent crystals are very hard since the bond is strong. The best example is diamond which is the hardest naturally occurring material and possess high melting and boiling points, but generally lower than that for ionic crystals.
  2. Their conductivity falls in the range between insulators and semiconductors. For example, Si and Ge are semiconductors, whereas diamond as an insulator.
  3. They are transparent to electromagnetic waves in infrared region, but opaque at shorter wavelengths.
- They are brittle and hard.  
They are not soluble in polar liquids, but they dissolve in non-polar liquids such as ether, acetone, benzene etc.  
The bonding is highly directional.

## 3. Metallic Bonding:

The valence electrons from all the atoms belonging to the crystal are free to move throughout the crystal. The crystal may be considered as an array of positive metal ions embedded in a cloud of free electrons. This type of bonding is called metallic bonding.

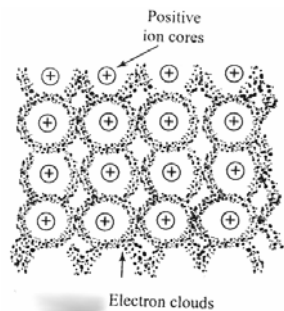

**Fig.** Atomic arrangement in metal crystal.

In a solid even a tiny portion of it comprises of billions of atoms. Thus in a metallic body, the no. of electrons that move freely will be so large that it is considered as though there is an electron gas contained within the metal. The atoms lay embedded in this gas but having lost the valence electrons, they become positive ions. The electrostatic interaction between these positive ions and the electron gas as a whole, is responsible for the metallic bonding.

### **Properties:**

1. Compared to ionic and covalent bonds, the metallic bonds are weaker. Their melting and boiling points are also lower.
2. Because of the easy movement possible to them, the electrons can transport energy efficiently. Hence all metals are excellent conductors of heat and electricity.
3. They are good reflectors and are opaque to E.M radiation.
4. They are ductile and malleable.

### **Secondary Bonds**

There are two types of secondary bonds. They are Vander Waal's bonds and Hydrogen bonds.

1. **Vander Waal's bonding:** Vander Waal's bonding is due to Vander Waal's forces. These forces exist over a very short range. The force decreases as the 4<sup>th</sup> power of the distance of separation between the constituent atoms or molecules when the ambient temperature is low enough. These forces lead to condensation of gaseous to liquid state and even from liquid to solid state though no other bonding mechanism exists. (except He)

### **Properties:**

1. The bonding is weak because of which they have low melting points.
  2. They are insulators and transparent for visible and UV light.
  3. They are brittle.
  4. They are non-directional
2. **Hydrogen bonding:** Covalently bonded atoms often produce an electric dipole configuration. With hydrogen atom as the positive end of the dipole if bonds arise as a result of electrostatic attraction between atoms, it is known as hydrogen bonding.



FIG.....

**Properties:**

1. The bonding is weak because of which they have low melting points.
2. They are insulators and transparent for visible and UV light.
3. They are brittle.
4. The hydrogen bonds are directional.

**Forces between atoms:**

In solid materials, the forces between the atoms are of two kinds. 1) Attractive force 2) Repulsive force

To keep the atoms together in solids, these forces play an important role. When the atoms are infinitely far apart they do not interact with each other to form a solid and the potential energy will be zero. From this, it can be understood that the potential energy between two atoms is inversely proportional to some power of the distance of separation. In all atoms, moving electric charges will be present, hence either attractive interaction or repulsive interaction takes place as they approach each other.

The attractive forces between the atoms bring them close together until a strong repulsive force arises due to overlap of electron shell. The atoms attract each other when they come close to each other due to inter-atomic attractive force which is responsible for bond formation. Suppose two atoms A and B experiences attractive and repulsive forces on each other, then the interatomic or bonding force 'f(r)' between them may be represented as

$$F(r) = A / r^M - B / r^N \quad (N > M) \text{-----(1)}$$

Where 'r' is the interatomic distance

A, B, M, N are constants.

In eqn-1, the first term represents attractive force and the second the repulsive force.

At larger separation, the attractive force predominates. The two atoms approach until they reach equilibrium spacing. If they continue to approach further, the repulsive force predominates, tending to push them back to their equilibrium spacing.

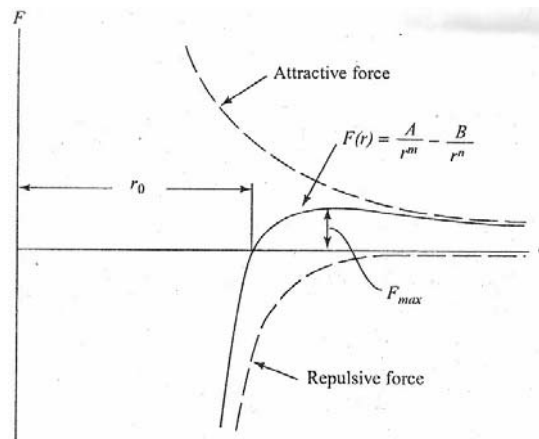

Fig. Variation of interatomic force with interatomic spacing

To calculate equilibrium spacing  $r_0$  :

The general expression for bonding force between two atoms is

$$F(r) = A / r^M - B / r^N$$

At equilibrium spacing  $r = r_0$ ,  $F = 0$

$$\text{Hence} \quad A / r_0^M = B / r_0^N$$

$$\text{i.e.} \quad (r_0)^{N-M} = B / A$$

$$\text{or} \quad r_0 = (B / A)^{1 / (N-M)}$$

Cohesive energy:

The energy corresponding to the equilibrium position  $r = r_0$  is called the bonding energy or the energy of cohesion of the molecule. Since this is the energy required to dissociate the atoms, this is also called the energy of dissociation.

The potential energy or stored internal energy of a material is the sum of the individual energies of the atoms plus their interaction energies. Consider the atoms are in the ground state and are infinitely far apart. Hence they do not interact with each other to form a solid. The potential energy, which is inversely proportional to some power of the distance of separation, is nearly zero. The potential energy varies greatly with inter-atomic separation. It is obtained by integrating the eqn –(1)

$$\begin{aligned} U(r) &= \int F(r) dr \\ &= \int [ A/r^M - B/r^N ] dr \\ &= [ (A/1-M) r^{1-M} - (B/1-N) r^{1-N} ] + c \\ &= [ -(A/M-1) r^{-(M-1)} + (B/N-1) r^{-(N-1)} ] + c \end{aligned}$$

$$= -a / r^m + b / r^n + c \quad \text{where } a = A/M-1, b = B/N-1, m = M-1, n = N-1$$

At  $r = \alpha$ ,  $U(r) = 0$ , then  $c = 0$

Therefore  $U(r) = -a / r^m + b / r^n$

The condition under which the particles form a stable lattice is that the function  $U(r)$  exhibits min. for a finite value of  $r$  i.e.  $r = r_0$  this spacing  $r_0$  is known as equilibrium spacing of the system. This min. energy  $U_{\min}$  at  $r = r_0$  is negative and hence the energy needed to dissociate the molecule then equals the positive quantity of  $(-U_{\min})$ .  $U_{\min}$  occurs only if  $m$  and  $n$  satisfy the condition  $n > m$

When the system in equilibrium then  $r = r_0$  and  $U(r) = U_{\min}$

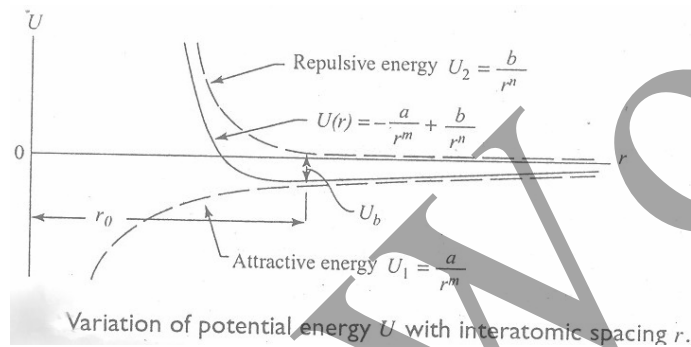

$$[dU / dr]_{r=r_0} = 0$$

$$= d / dr [-a / r_0^m + b / r_0^n] = 0$$

$$\text{or } 0 = [a m r_0^{-m-1}] - [b n r_0^{-n-1}]$$

$$\text{or } 0 = [a m / r_0^{m+1}] - [b n / r_0^{n+1}] \quad \text{-----} \rightarrow (2)$$

Solving for  $r_0$

$$r_0 = [(b / a) (n / m)]^{1/n-m}$$

$$\text{or } r_0^n = r_0^m [(b / a) (n / m)]$$

at the same time,  $n > m$  to prove this,

$$[d^2U / dr^2]_{r=r_0} = -[a m(m+1) / r_0^{m+2}] + [b n(n+1) / r_0^{n+2}] > 0$$

$$[r_0^{m+2} b n(n+1)] - [r_0^{n+2} a m(m+1)] > 0$$

$$r_0^m b n(n+1) > r_0^n a m(m+1)$$

$$b n(n+1) > a m(m+1) r_0^{n-m}$$

$$b n(n+1) > a m(m+1) (b / a) (n / m)$$

i.e.  $n > m$

### Calculation of cohesive energy:

The energy corresponding to the equilibrium position  $r = r_0$ , denoted by  $U(r_0)$  is called bonding energy or cohesive energy of the molecule.

Substituting ' $r_0^n$ ' in expression for  $U_{\min}$ ,

We get

$$\begin{aligned} U_{(\min)} &= -a/r_0^m + b/r_0^n \\ &= -a/r_0^m + b(a/b)(m/n)1/r_0^m \\ &= -a/r_0^m + (m/n)(a/r_0^m) \\ &= -a/r_0^m[1-m/n] \\ U_{\min} &= -a/r_0^m[1-m/n] \end{aligned}$$

Thus the min. value of energy of  $U_{\min}$  is negative. The positive quantity  $|U_{\min}|$  is the dissociation energy of the molecule, i.e. the energy required to separate the two atoms.

### Calculation of cohesive energy of NaCl Crystal

Let Na and Cl atoms be free at infinite distance of separation. The energy required to remove the outer electron from Na atom (ionization energy of Na atom), leaving it a  $\text{Na}^+$  ion is 5.1eV.



The electron affinity of Cl is 3.6eV. Thus when the removed electron from Na atom is added to Cl atom, 3.6eV of energy is released and the Cl atom becomes negatively charged.



Net energy =  $5.1 - 3.6 = 1.5$  eV is spent in creating  $\text{Na}^+$  and  $\text{Cl}^-$  ions at infinity.

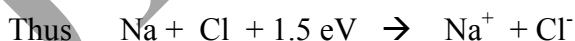

At equilibrium spacing  $r_0 = 0.24\text{nm}$ , the potential energy will be min. and the energy released in the formation of NaCl molecule is called bond energy of the molecule and is obtained as follows:

$$\begin{aligned} V &= e^2 / 4\pi\epsilon_0 r_0 \\ &= - [(1.602 \times 10^{-19})^2 / 4\pi(8.85 \times 10^{-12})(2.4 \times 10^{-10})] \text{ joules} \end{aligned}$$

$$= - [ (1.602 \times 10^{-19})^2 / 4\pi(8.85 \times 10^{-22} \times 2.4)(1.602 \times 10^{-19}) ] \text{ eV}$$

$$= -6 \text{ eV}$$

Thus the energy released in the formation of NaCl molecule is  $(5.1 - 3.6 - 6) = -4.5 \text{ eV}$

To dissociate NaCl molecule into  $\text{Na}^+$  and  $\text{Cl}^-$  ions, it requires energy of 4.5 eV.

### **Madelung Constant**

Let  $r$  be the distance of separation between the two ions,  $z_1$  and  $z_2$  be the atomic numbers of the respective nuclei.

The coulomb's force of attraction  $F$  between the positive and negative ions is,

$$F = (z_1 z_2) e^2 / 4\pi\epsilon_0 r^2$$

The work done while they move under the attractive force towards each other through a distance  $dr$ ,

$$W = Fdr = [ (z_1 z_2) e^2 / 4\pi\epsilon_0 r^2 ] dr$$

Therefore the work done while they move from infinite distance of separation to a distance  $r$ ,

$$= \int_{\infty}^r fdr = [ (z_1 z_2) e^2 / 4\pi\epsilon_0 ] \int_{\infty}^r dr / r^2$$

$$= - (z_1 z_2) e^2 / 4\pi\epsilon_0 r$$

Work done by them becomes the attractive potential energy  $U_a$

$$\text{Therefore } U = - (z_1 z_2) e^2 / 4\pi\epsilon_0 r$$

$$= -\alpha [ e^2 / 4\pi\epsilon_0 r ]$$

Where  $\alpha$  is constant called Madelung constant which has different values for different crystals.

## 2. CRYSTALLOGRAPHY AND CRYSTAL STRUCTURES

### CRYSTALLOGRAPHY

The branch of science which deals with the study of geometric form and other physical properties of the crystalline solids by using X-rays, electron beam, and neutron beams etc is called crystallography or crystal physics.

The solids are classified into two types crystalline and amorphous. A substance is said to be crystalline, when the arrangement of atoms, molecules or ions inside it is regular and periodic. Ex. NaCl, Quartz crystal. Though two crystals of same substance may look different in external appearance, the angles between the corresponding faces are always the same. In amorphous solids, there is no particular order in the arrangement of their constituent particles. Ex. Glass.

#### CRYSTALLINE SOLIDS

1. Crystalline solids have regular periodic Arrangement of particles (atoms, ions, Or molecules).
2. They are un-isotropic i.e., they differ in Properties with direction.
3. They have well defined melting and Freezing points. Melting and freezing points occurs at different temperatures at different locations in the solids.
4. Crystalline solids may be made up of materials are metallic crystals or non-metallic crystals. Some of the metallic crystals are Copper, silver, aluminum, tungsten, and manganese. Non-metallic crystals are crystalline carbon, crystallized polymers or plastics.
5. Metallic crystals have wide use in engineering because of their favorable Properties of strength, ductility, conductivity and reflection.

#### AMORPHOUS SOLIDS

1. Amorphous solids have no regularity in the arrangement Of particles.
2. They are usually isotropic i.e., They possess same properties in different directions.
3. They do not possess well defined melting and freezing points.
4. Most important amorphous glasses, plastics and rubber.
5. An amorphous structure does not generally possess elasticity but only plasticity.

**Lattice points:** They are the imaginary points in space about which the atoms are located.

**Lattice:** The regular repetition of atomic, ionic or molecular units in 2-dimensional, 3-dimensional space is called lattice.

**Space lattice or Crystal lattice:** The totality of all the lattice point in space is called space lattice, the environment about any two points is same or An array of points in space such that the environment about each point is the same.

Consider the case of a 2-dimensional array of points.

Let O be any arbitrary point as origin,  $r_1, r_2$  are position vectors of any two lattice points joining to O.

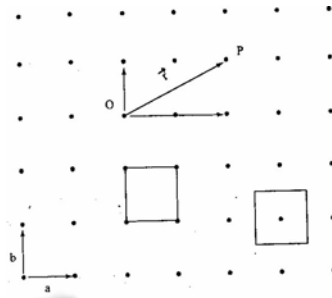

Fig. A two-dimensional square array of points.

If  $T$  (translational vector) is the difference of two vectors  $r_1, r_2$  and if it satisfies the condition

$$T = n_1 a + n_2 b \quad \text{where } n_1, n_2 \text{ are integers}$$

Then  $T$  represent 2-dimensional lattice.

For 3- dimensional lattice,

$$T = n_1 a + n_2 b + n_3 c$$

Note: crystal lattice is the geometry of set of points in space where as the structure of the crystal is the actual ordering of the constituent ions, atoms, molecules in space

### Basis and Crystal structure:

Basis or pattern is a group of atoms, molecule or ions identical in composition, arrangement and orientation. When the basis is repeated with correct periodicity in all directions, it gives the actual crystal structure.

$$\text{Crystal structure} = \text{Lattice} + \text{Basis}$$

FIG.....

The crystal structure is real while the lattice is imaginary.

In crystalline solids like Cu and Na, the basis is a single atom

In NaCl and CsCl- basis is diatomic

In  $\text{CaF}_2$  – basis is triatomic

### Unit cell and Lattice parameters:

Unit cell is the smallest portion of the space lattice which can generate the complete crystal by repeating its own dimensions in varies directions. In describing the

crystal structure, it is convenient to subdivide the structure into small repetitive entities called unit cells. Unit cell is the parallelepiped or cubes having 3 sets of parallel faces. It is the basic structural unit or the building block of the crystal.

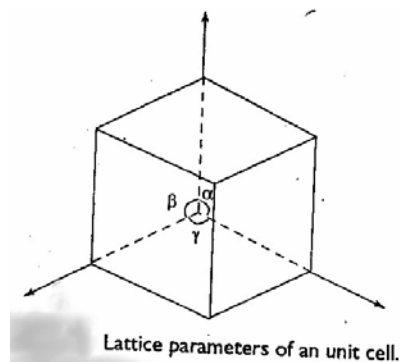

A unit cell can be described by 3 vectors or intercepts **a**, **b**, **c**, the lengths of the vectors and the interfacial angles  $\alpha$ ,  $\beta$ ,  $\gamma$  between them. If the values of these intercepts and interfacial angles are known, then the form and actual size of the unit cell can be determined. They may or may not be equal. Based on these conditions, there are 7 different crystal systems.

**Primitive Cell:** A unit cell having only one lattice point at the corners is called the primitive cell. The unit cell differs from the primitive cell in that it is not restricted to being the equivalent of one lattice point. In some cases, the two coincide. Thus, unit cells may be primitive cells, but all the primitive cells need not be unit cells.

### CRYSTAL SYSTEMS AND BRAVAIS LATTICES:

There are 7 basic crystal systems which are distinguished based on three vectors or the intercepts and the 3 interfacial angles between the 3 axes of the crystal. They are

1. Cubic
2. Tetragonal
3. Orthorhombic
4. Monoclinic
5. Triclinic
6. Trigonal ( Rhombohedral )
7. Hexagonal

More space lattices can be constructed by atoms at the body centres of unit cells or at the centres of the faces. Based on this property, Bravais classified the space lattices into 14.

#### 1. Cubic crystal system

$$a = b = c, \alpha = \beta = \gamma = 90^\circ$$

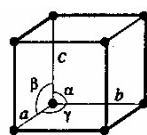

Simple

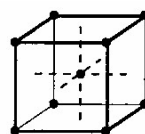

Body-centered  
(bcc)

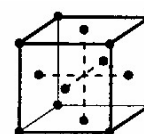

Face-centered  
(fcc)

$$a = b = c, \alpha = \beta = \gamma = 90^\circ$$



The crystal axes are perpendicular to one another, and the repetitive interval in the same along all the three axes. Cubic lattices may be simple, body centered or face-centered.

## 2. Tetragonal crystal system

$$a = b \neq c, \alpha = \beta = \gamma = 90^\circ$$

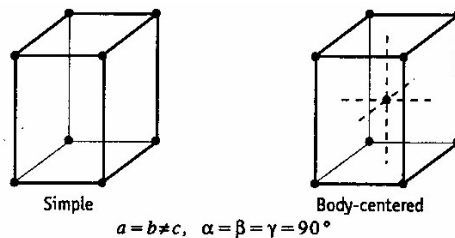

$$a = b \neq c, \alpha = \beta = \gamma = 90^\circ$$

TETRAGONAL SYSTEM

The crystal axes are perpendicular to one another. The repetitive intervals along the two axes are the same, but the interval along the third axis is different. Tetragonal lattices may be simple or body-centered.

## 3. Orthorhombic crystal system.

$$a \neq b \neq c, \alpha = \beta = \gamma = 90^\circ$$

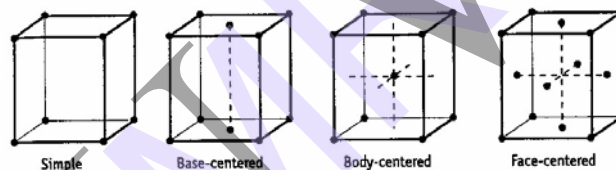

$$a \neq b \neq c; \text{ and } \alpha = \beta = \gamma = 90^\circ$$

ORTHORHOMBIC SYSTEM

The crystal axes are perpendicular to one another but the repetitive intervals are different along the three axes. Orthorhombic lattices may be simple, base centered, body centered or face centered.

## 4. Monoclinic crystal system

$$a \neq b \neq c, \alpha = \beta = 90^\circ \neq \gamma$$

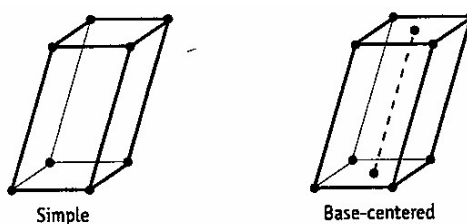

$$a \neq b \neq c, \alpha = \gamma = 90^\circ \neq \beta$$

MONOCLINIC SYSTEM

Two of the crystal axes are perpendicular to each other, but the third is obliquely inclined. The repetitive intervals are different along all the three axes. Monoclinic lattices may be simple or base centered.

### 5. Triclinic crystal system

$$a \neq b \neq c, \alpha \neq \beta \neq \gamma \neq 90^\circ$$

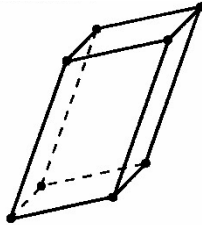

$$a \neq b \neq c \\ \alpha \neq \beta \neq \gamma \neq 90^\circ \\ \text{TRICLINIC SYSTEM}$$

None of the crystal axes is perpendicular to any of the others, and the repetitive intervals are different along the three axes.

### 6. Trigonal(rhombohedral) crystal system

$$a = b = c, \alpha = \beta = \gamma \neq 90^\circ$$



$$a = b = c \\ \alpha = \beta = \gamma \neq 90^\circ \\ \text{RHOBOHEDRAL (TRIGONAL) SYSTEM}$$

The three axes are equal in length and are equally inclined to each other at an angle other than  $90^\circ$

### 7. Hexagonal crystal system.

$$a = b \neq c, \alpha = \beta = \gamma = 90^\circ, \gamma = 120^\circ$$

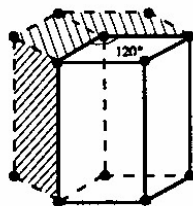

$$a = b \neq c \\ \alpha = \beta = 90^\circ, \gamma = 120^\circ \\ \text{HEXAGONAL SYSTEM}$$

Two of the crystal axes are  $60^\circ$  apart while the third is perpendicular to both of them. The repetitive intervals are the same along the axes that are  $60^\circ$  apart, but the interval along the third axis is different.

### Basic Crystal Structures:

The important fundamental quantities which are used to study the different arrangements of atoms to form different structure are

1. **Nearest neighbouring distance** ( $2r$ ) : the distance between the centres of two nearest neighbouring atoms is called nearest neighbouring distance. If  $r$  is the radius of the atom, nearest neighbouring distance =  $2r$ .
2. **Atomic radius** ( $r$ ) : It is defined as of the distance between the nearest neighbouring atoms in a crystals.
3. **Coordination number** ( $N$ ): It is defined as the number of equidistant nearest neighbours that an atom as in a given structure. More closely packed structure as greater coordination number.
4. **Atomic packing factor or fraction**: It is the ratio of the volume occupied by the atoms in unit cell( $v$ ) to the total volume of the unit cell ( $V$ ).

$$\text{P.F.} = v / V$$

### Simple cubic (SC) structure:

In the simple cubic lattice, there is one lattice point at each of the 8 corners of the unit cell. The atoms touch along cubic edges.

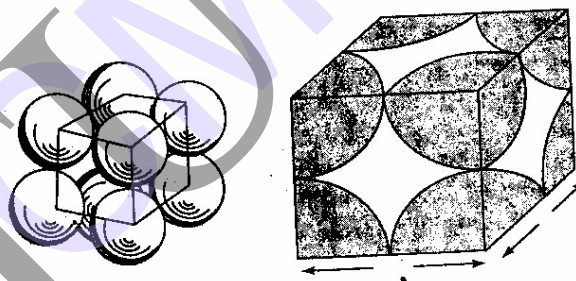

Fig. Simple Cubic Structure

Nearest neighbouring distance =  $2r = a$

Atomic radius =  $r = a / 2$

Lattice constant =  $a = 2r$

Coordination number = 6 ( since each corner atom is surrounded by 6 equidistant nearest neighbours )

Effective number of atoms belonging to the unit cell or no. of atoms per unit cell =  $(\frac{1}{8}) \times 8 = 1$  atom per unit cell.

Atomic packing factor =  $v / V_{-} = \frac{\text{volume of the all atoms in the unit cell}}{\text{volume of the unit cell.}}$

$$= 1 \times (4 / 3) \pi r^3 / a^3 = 4\pi r^3 / 3(2r)^3$$

$$= \pi / 6 = 0.52 = 52\%$$

This structure is loosely packed. Polonium is the only element which exhibits the simple cubic structure.

### Body centered cube structure (BCC):

BCC structure has one atom at the centre of the cube and one atom at each corner. The centre atom touches all the 8 corner atoms.

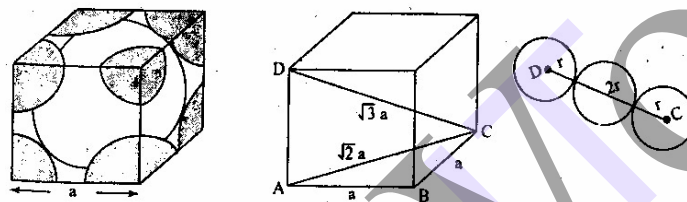

Fig. Body Centered Cubic Structure

Diagonal length =  $4r$

Body diagonal =  $(\sqrt{3})a$

i.e.  $4r = (\sqrt{3})a$

Nearest neighbouring distance =  $2r = (\sqrt{3})a / 2$

Atomic radius =  $r = (\sqrt{3})a / 4$

Lattice constant =  $a = 4r / \sqrt{3}$

Coordination number = 8 (since the central atom touches all the corner 8 atoms)

Effective number of atoms belonging to the unit cell or no. of atoms per unit cell =  $(\frac{1}{8}) \times 8 + 1 = 2$  atom per unit cell.

i.e. each corner atom contributes  $\frac{1}{8}$ th to the unit cell. In addition to it, there is a centre atom.

Atomic packing factor =  $v / V_{-} = \frac{\text{volume of the all atoms in the unit cell}}{\text{volume of the unit cell.}}$

$$= 2 \times (4/3) \pi r^3 / a^3 = 8\pi r^3 / 3(4r/\sqrt{3})^3$$

$$= \sqrt{3} \pi / 8 = 0.68 = 68\%$$

Tungsten, Na, Fe and Cr exhibits this type of structure.

### Face centered cubic (FCC) structure:

In FCC structure, there is one lattice point at each of the 8 corners of the unit cell and 1 centre atom on each of the 6 faces of the cube.

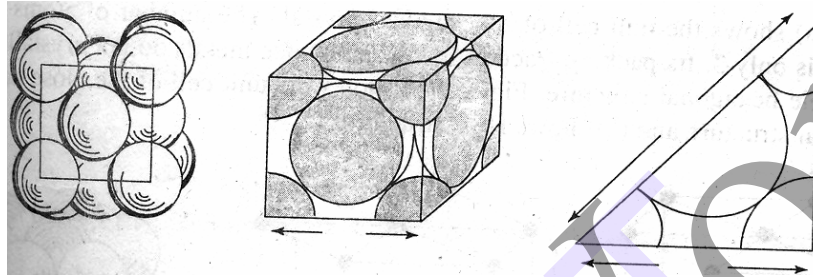

Fig. Face Centered Cubic Structure

$$\text{Face diagonal length} = 4r = (\sqrt{2}) a$$

$$\text{Nearest neighbouring distance} = 2r = (\sqrt{2})a / 2 = a / \sqrt{2}$$

$$\text{Atomic radius} = r = a / 2\sqrt{2}$$

$$\text{Lattice constant} = a = 2\sqrt{2} r$$

Coordination number = 12 ( the centre of each face has one atom. This centre atom touches 4 corner atoms in its plane, 4 face centered atoms in each of the 2 planes on either side of its plane)

Effective number of atoms belonging to the unit cell or no. of atoms per unit cell =  $(1/8) \times 8 + (1/2) \times 6 = 1 + 3 = 4$  atom per unit cell.

i.e. each corner atom contributes  $1/8$ th to the unit cell. In addition to it, there is a centre atom on each face of the cube.

$$\text{Atomic packing factor} = v / V = \frac{\text{volume of the all atoms in the unit cell}}{\text{Volume of the unit cell.}}$$

$$= 4 * (4/3) \pi r^3 / a^3 = 16\pi r^3 / 3(2\sqrt{2} r)^3$$

$$= \pi / 3\sqrt{2} = 0.74 = 74\%$$

Cu, Al, Pb and Ag have this structure. FCC has highest packing factor.

## UNIT - II

### 3. X-RAY DIFFRACTION

#### Directions & Planes in Crystals:

While dealing with the crystals, it is necessary to refer to crystal planes, and directions of straight lines joining the lattice points in a space lattice. For this purpose, an indexing system devised by Miller known as Miller indices is widely used.

#### Directions in A Crystal:

Consider a cubic lattice in which a straight line is passing through the lattice points A, B, C etc and 1 lattice point on the line such as point A is chosen as the origin.

Then the vector R which joins A to any other point on the line such as B (position vector) can be represented by the vector eqn.

$$R = n_1 a + n_2 b + n_3 c \text{----- (1) where } a, b, c \text{ are basic vectors}$$

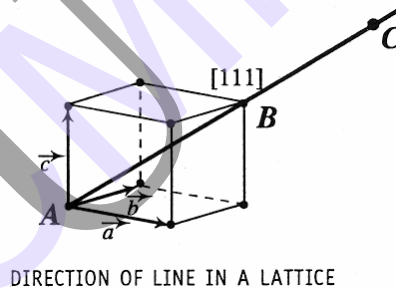

The direction of the vector R depends on the integers  $n_1, n_2, n_3$  since  $a, b, c$  are constants.

The common multiple is removed and  $n_1, n_2, n_3$  are re-expressed as the smallest integers bearing the same relative ratio. The direction is then specified as  $[n_1 n_2 n_3]$ .

$$R = a + b + c, \text{ which provides the value of 1 for each of } n_1, n_2, n_3$$

Thus the direction is denoted as  $[1 1 1]$ .

All lines in the space lattice which are parallel to the line AB possess either same set of values for  $n_1, n_2, n_3$  as that of AB, or its common multiples.

**Ex:** 1. The direction that connects the origin and  $(1/3, 1/3, 2/3)$  point is  $[1 1 2]$ .

$$\text{i.e., } (1/3, 1/3, 2/3)$$

$$\text{L.C.M} = 3.$$

$$(1/3 \times 3 \quad 1/3 \times 3 \quad 2/3 \times 3) = [1 \ 1 \ 2].$$

2.  $[2 \ 1 \ 1]$  is the direction that connects the origin  $(0, 0, 0)$  and point  $(1, 1/2, 1/2)$

Largest Number = 2

$$(2/2, 1/2, 1/2) = (1, 1/2, 1/2)$$

### Planes in Crystals ( *Miller Indices* ):

It is possible for defining a system of parallel and equidistant planes which can be imagined to pass through the atoms in a space lattice, such that they include all the atoms in the crystal. Such a system of planes is called crystal planes. Many different systems of planes could be identified for a given space lattice.

The position of a crystal plane can be specified in terms of three integers called Miller indices.

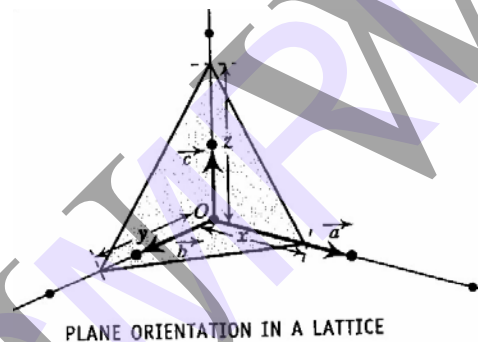

Consider a crystal plane intersecting the crystal axes.

Procedure for finding Miller indices

1. Find the intercepts of the desired plane on the three coordinate axes.  
Let these be  $(pa, qb, rc)$ .
2. Express the intercepts as multiples of unit cell dimensions or lattice parameters i.e.  $(p, q, r)$
3. Take the reciprocals of these numbers i.e.  $1/p: 1/q: 1/r$
4. Convert these reciprocals into whole numbers by multiplying each with their LCM to get the smallest whole number.

This gives the Miller indices  $(h \ k \ l)$  of the plane.

Ex:  $(3a, 4b, \alpha c)$

$(3, 4, \alpha)$

$$1/3 \quad 1/4 \quad 1/a$$

$$(4 \ 3 \ 0) = (h, k, l)$$

Def: Miller indices is a set of 3 lowest possible integers whose ratio taken in order is the same as that of the reciprocals of the intercepts of the planes on the corresponding axes in the same order.

### Important features of Miller indices:

1. When a plane is parallel to any axis, the intercept of the plane on that axis is infinity. Hence its Miller index for that axis is zero.
2. When the intercept of a plane on any axis is negative, a bar is put on the corresponding Miller index.
3. All equally spaced parallel planes have the same index number (h k l)

Ex : The planes ( 1 1 2) and (2 2 4) are parallel to each other.

### Separation Between successive (h k l) Planes:

Let (h k l) be the Miller indices of the plane ABC.

Let  $OP=d_{hkl}$  be the normal to the plane ABC passing through the origin O.

Let OP make angles  $\alpha, \beta, \gamma$  with X, Y & Z axes respectively.

Then  $\cos \alpha = d / OA = d / x = d / (a / h)$

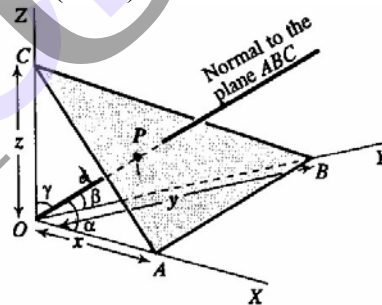

Fig. Interplanar Spacing.

$$\cos \beta = d / OB = d / y = d / (b / k)$$

$$\cos \gamma = d / OC = d / z = d / (c / l)$$

(Since convention in designing Miller indices  $x=a/h, y=b/k, z=c/l$ )

$$\text{Now } \cos^2 \alpha + \cos^2 \beta + \cos^2 \gamma = 1$$

$$\text{Hence } d^2 / (a / h)^2 + d^2 / (b / k)^2 + d^2 / (c / l)^2 = 1$$



$$\rightarrow (d h / a)^2 + (d k / b)^2 + (d l / c)^2 = 1$$

$$\rightarrow d_{(hkl)} = OP = 1 / \sqrt{(h^2/a^2 + k^2/b^2 + l^2/c^2)}.$$

Therefore for cubic structure,  $a=b=c$ ,

$$d_{(hkl)} = a / \sqrt{(h^2 + k^2 + l^2)}$$

Let the next plane be parallel to ABC be at a distance OQ from the origin. Then its intercepts are  $2a / h, 2a / k, 2a / l$ .

$$\text{Therefore } OQ = 2d = 2a / \sqrt{(h^2 + k^2 + l^2)}$$

Hence the spacing between adjacent planes = OQ - OP = PQ.

$$\text{i.e. } d = a / \sqrt{(h^2 + k^2 + l^2)}$$

### **Expression for Space Lattice Constant 'a' For a Cubic Lattice:**

Density  $\rho = (\text{total mass of molecules belonging to unit cell}) / (\text{volume of unit cell})$

Total mass of molecule belonging to unit cell =  $nM / N_A$

Where n-number of molecules belonging to unit cell

M-Molecular weight

$N_A$  -Avagadro Number

Volume of cube =  $a^3$

Therefore  $\rho = nM / a^3 N_A$

Or  $a^3 = nM / \rho N_A$

Lattice Constant for Cubic Lattice  $a = (nM / \rho N_A)^{1/3}$ .

### **Diffraction of X- Rays by Crystal Planes:**

X-Rays are electromagnetic waves like ordinary light, therefore, they should exhibit interference and diffraction. Diffraction occurs when waves pass across an object whose dimensions are of the order of their own wavelengths. The wavelength of X-rays is of the order of 0.1nm or  $10^{-8}$  cm so that ordinary devices such as ruled diffraction gratings do not produce observable effects with X-rays. Laue suggested that a crystal which consisted of a 3-dimensional array of regularly spaced atoms could serve the purpose of a grating. The crystal differs from ordinary grating in the sense that the diffracting centers in the crystal are not in one plane. Hence the crystal acts as a space grating rather than a plane grating. There are 3 main X-ray diffraction methods by which the crystal structure can be analysed.

- (1) Laue Method – for single crystal
- (2) Powder Method- for finely divided crystalline or polycrystalline powder
- (3) Rotating crystal Method - for single crystal

### **Bragg's Law:**

It states that the X-rays reflected from different parallel planes of a crystal interfere constructively when the path difference is integral multiple of wavelength of X-rays.

Consider a crystal made up of equidistant parallel planes of atoms with the interplanar spacing  $d$ .

Let wave front of a monochromatic X-ray beam of wavelength  $\lambda$  fall at an angle  $\theta$  on these atomic planes. Each atom scatters the X-rays in all directions.

In certain directions these scattered radiations are in phase i.e. they interfere constructively while in all other directions, there is destructive interference.

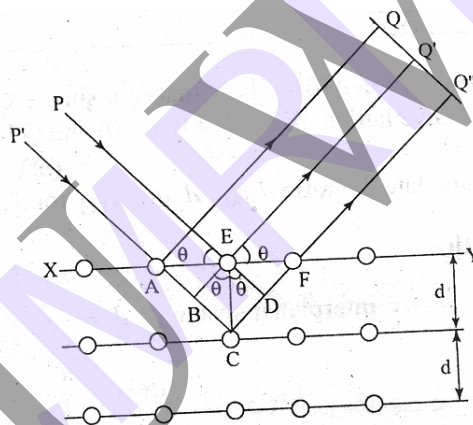

**Figure 1 X-Ray Scattering by Crystal.**

Consider the X-rays PE and P'A are inclined at an angle  $\theta$  with the top of the crystal plane XY. They are scattered along AQ and EQ' at an angle  $\theta$  w.r.t plane XY. Consider another incoming beam P'C is scattered along CQ''

Let normal EB & ED be drawn to AC & CF. If EB & ED are parallel incident and reflected wave fronts then the path difference between the incident and reflected waves is given by

$$\Delta = BC + CD \text{ -----(1)}$$

In  $\Delta ABC$ ,  $\sin \theta = BC / EC = BC / d$

$$\text{i.e. } BC = d \sin \theta$$

Similarly, in  $\Delta DEC$ ,  $CD = d \sin \theta$

Hence path difference  $\Delta = 2d \sin \theta$

If the 2 consecutive planes scatter waves in phase with each other, then the path difference must be an integral multiple of wavelength.

$$\text{i.e. } \Delta = n\lambda \quad \text{where } n = 0, 1, 2, 3, \dots \text{ is the order of reflection}$$

Thus the condition for in phase scattering by the planes in a crystal is given by

$$2d \sin \theta = n\lambda \quad \dots \dots \dots (2)$$

This condition is known as Bragg's Law.

The maximum possible value for  $\theta$  is  $90^\circ$ .

$$n\lambda / 2d \leq 1$$

the wavelength  $\lambda$  should not exceed twice the inter planar spacing for diffraction to occur.

**Laue Method:**  $S_1$  &  $S_2$  are 2 lead screens in which 2 pin holes act as slits. X-ray beam from an X-ray tube is allowed to pass through these 2 slits  $S_1$  &  $S_2$ . The beam transmitted through  $S_2$  will be a narrow pencil of X-rays. The beam proceeds further to fall on a single crystal such that Zinc blende (ZnS) which is mounted suitably on a support. The single crystal acts as a 3-dimensional diffraction grating to the incident beam. Thus, the beam undergoes diffraction in the crystal and then falls on the photographic film. The diffracted waves undergo constructive interference in certain directions, and fall on the photographic film with reinforced intensity. In all other directions, the interference will be destructive and the photographic film remains unaffected.

The resultant interference pattern due to diffraction through the crystal as a whole will be recorded on the photographic film (which requires many hours of exposure to the incident beam). When the film is developed, it reveals a pattern of fine spots, known as Laue spots.

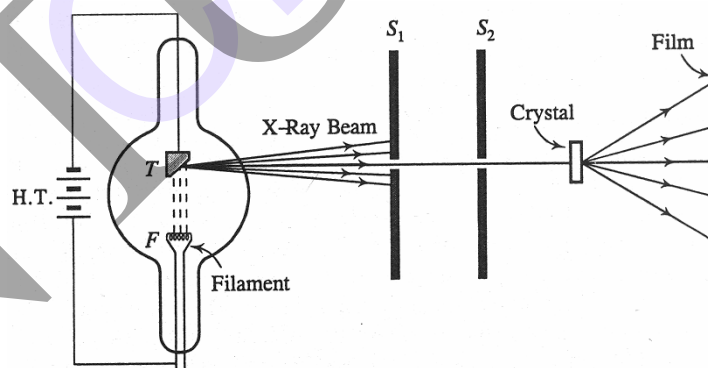

X-RAY DIFFRACTION (LAUE'S METHOD)

The distribution spots follow a particular way of arrangement that is the characteristic of the specimen used in the form of crystal to diffract the beam. The Laue spot photograph obtained by diffracting the beam at several orientations of the crystal to the incident beam are used for determining the symmetry and orientations of the internal arrangement of atoms, molecules in the crystal lattice. It is also used to study the imperfections in the crystal.

## POWDER METHOD ( Debye – Scherrer Method ):

This method is widely used for experimental determination of crystal structures. A monochromatic X- ray beam is incident on randomly oriented crystals in powder form. In this we used a camera called Debye – Scherrer camera. It consists of a cylindrical cassette, with a strip of photographic film positioned around the circular periphery of cassette. The powder specimen is placed at the centre, either pasted on a thin fibre of glass or filled in a capillary glass tube. The X- ray beam enters through a small hole in the camera and falls on the powder specimen. Some part of the beam is diffracted by the powder while the remaining passes out through the exit port.

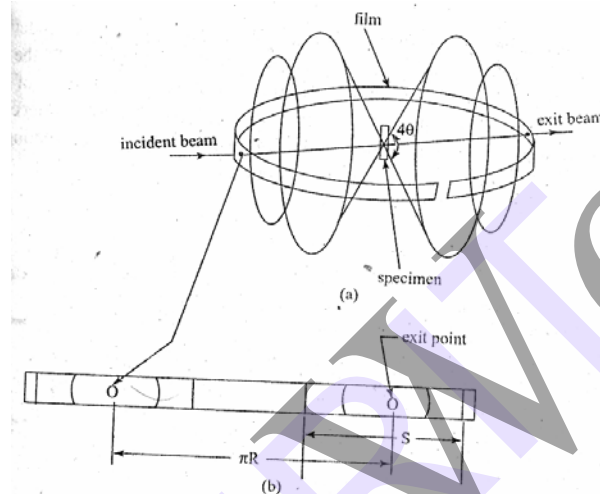

Since large no. of crystals is randomly oriented in the powder, set of planes which make an angle  $\theta$  with the incident beam can have a no. of possible orientations. Hence reflected radiation lies on the surface of a cone whose apex is at the point of contact of the radiation with the specimen. If all the crystal planes of interplanar spacing  $d$  reflect at the same bragg angle  $\theta$ , all reflections from a family lie on the same cone.

After taking  $n=1$  in the Bragg's law

$$2d\sin\theta = \lambda$$

There are still a no of combinations of  $d$  and  $\theta$ , which satisfies Bragg's law. Hence many cones of reflection are emitted by the powder specimen. In the powder camera a part of each cone is recorded by the film strip.

The full opening angle of the diffracted cone  $4\theta$  is determined by measuring the distance  $S$  between two corresponding arcs on the photographic film about the exit point direction beam. The distance  $S$  on the film between two diffraction lines corresponding to a particular plane is related to bragg's angle by the equation

$$4\theta = (S / R) \text{ radians} \quad (\text{or})$$

$$4\theta = (S / R) \times (180 / \Pi) \text{ degrees} \quad \text{where } R\text{- radius of the camera}$$

A list of  $\theta$  values can be thus be obtained from measured values of  $S$ . Since the wavelength ' $\lambda$ ' is known, substitution of  $\lambda$  gives a list of spacing ' $d$ '.

Each spacing is the distance between neighbouring plane (h k l). From the ratio of interplanar spacing, the type of lattice can be identified.

## Questions

1. Explain the various types of bonding in crystals. Illustrate with examples.
2. Distinguish between ionic and covalent bonding in solids.
3. Obtain a relation between potential energy and inter atomic spacing of a molecule.
4. Derive an expression for cohesive energy of a solid.
5. Obtain an equation for total binding energy of sodium chloride crystal.
6. Differentiate between crystalline and amorphous solids.
7. Explain the terms i) Basis ii) Space lattice iii) Unit cell
8. Explain with neat diagram the following crystal structures.
  - i) simple cubic structure(SC)
  - ii) body centered cubic structure(BCC)
  - iii) face centered cubic structure (FCC)
9. What do you understand by packing density? Show that packing density for simple lattice, body centered lattice and face centered lattice is  $\frac{\pi}{6}$  ,  $\frac{\sqrt{3}\pi}{8}$  ,  $\frac{\sqrt{2}\pi}{6}$  respectively
10. Show that FCC is the most closely packed of the three cubic structures.
11. a) For a crystal having  $a \neq b \neq c$  and  $\alpha = \beta = \gamma = 90^\circ$ , what is the crystal system?  
 b) For a crystal having  $a \neq b \neq c$  and  $\alpha \neq \beta \neq \gamma \neq 90^\circ$ , what is the crystal system?  
 c) Can you specify the Bravais lattices for parts (a) and (b) explain.
12. Explain the special features of the three types of lattices of cubic crystals?
13. What are ionic crystals? Explain the formation of an ionic crystal and obtain an expression for its cohesive energy?
14. What is a Bravais lattice? What are the different space lattices in the cubic system?
15. What are the miller indices? How they obtained?
16. Derive the expression for the interplanar spacing between two adjacent planes of miller indices (h k l) in a cubic lattice of edge length 'a'.
17. Derive bragg's law
18. Describe Laue's method of determination of crystal structure.
19. Explain the powder method of crystal structure analysis.

## 4.DEFECTS IN CRYSTALS

**Introduction:** In actual crystals, imperfections or defects are always present and their nature and effects are important in understanding the properties of crystals.

The properties of materials which are not affected by the presence of defects in crystals are termed as the structure-insensitive properties. Ex: stiffness, density and electrical conductivity.

The properties of materials which are affected by the presence of defects in crystals are termed as the structure-sensitive properties. Ex: mechanical strength, crystal growth, magnetic hysteresis, dielectric strength, conduction in semiconductors, e.t.c.

The structural imperfections can be classified on the basis of their geometry as point, line, surface and the volume imperfections. The common types of point defects in solid materials can be divided into 3 classes:

- (1) lattice site defects such as vacancies and interstitial defects
- (2) compositional defects and
- (3) electronic defects

Line defects may be classified as

- (1) edge dislocation and
- (2) screw dislocation

Surface defects may be classified as

- (1) external surface defect represented by the discontinuity at the surface and
- (2) internal surface defect like grain boundaries, tilt boundaries, twin boundaries and stacking fault etc.

Volume defects occur due to the presence of air bubbles, internal cracks and empty spaces in crystals.

**Thermal Vibrations:** Mathematically, atoms in a perfect lattice should occupy exactly the sites to which they are attached. No crystal is perfectly rigid, since it can be deformed by finite forces. It is possible to displace the atoms from their ideal sites with a finite expenditure of energy due to thermal vibrations. The frequency of vibration is almost independent of temperature, but the amplitude increases with increasing temperature. When the vibrations become strong enough the atoms may break the bonds between them. Since the atoms interact with one another they tend to vibrate in synchronism. The thermal vibration of atoms of a solid, does not seriously disturb the perfect structure of the crystal.

**Point Defects:** point imperfections are lattice errors at isolated lattice points. They are imperfect point-like regions in the crystal and, therefore, they may be referred to as zero-dimensional imperfections. A point imperfection arises because of the absence of a matrix atom( an atom that would be present in a perfect crystal), the presence of an impurity atom or a matrix atom in the wrong place.

**Vacancy Defect:** It is the simplest point defect in a crystal. This refers to a missing atom or vacant atomic site. Such defects may arise either from imperfect packing during the original crystallization or from thermal vibration of the atoms at high temperatures. When thermal energy due to vibration is increased there is an increased probability that individual atoms will jump out of their positions of lowest energy. Vacancies may be single or two.

**Interstitialcies:** In a closely packed structure, if the atomic packing factor is low, an extra atom may be lodged or introduced within the crystal structure. This is known as interstitial. An atom can enter the interstitial void or space between the regularly positioned atoms only when it is substantially smaller than the parent atoms, otherwise it will produce atomic distortions. Interstitials may be single, di and tri interstitials.

**Schottky Defect and Frenkel Defect:** In non-metallic crystals, the formation of a vacancy involves a local readjustment of charge in the surrounding crystal such that charge neutrality is maintained in the crystal. If in an ionic crystal there is a vacancy in a positive-ion site, charge neutrality may be achieved by creating vacancy in a neighbouring negative-ion site. Such a pair of vacant sites is called schottky defect.

On the other hand, if the charge neutrality is maintained by having a positive ion in an interstitial position, the pair constitutes a Frenkel defect.

Close-packed structures have fewer interstitials and Frenkel defects than vacancies and Schottky defects, as additional energy is required to force the atoms in their new positions.

As a result of thermal fluctuations, vacancies are produced and destroyed constantly in crystal. As a result the disorder increases resulting in an increase in the entropy. In thermal equilibrium, a certain number of lattice vacancies are always present which can be estimated as follows:

Let  $E_v$  be the energy required to take an atom from the lattice site.

$n E_v$  – increase in energy associated with the generation of  $n$  isolated vacant sites.

Total number of ways in which  $n$ -atoms can be picked up from the crystal consisting of  $N$  atoms is given by

$$P = \frac{N!}{(N-n)! n!} \quad \text{-----(1)}$$

Since disorder increases due to the creation of  $n$  vacancies the increase in entropy is given by

$$\begin{aligned} S &= K_B \log P \\ &= K_B \log \left[ \frac{N!}{(N-n)! n!} \right] \quad \text{-----(2)} \end{aligned}$$

Increase in entropy further produces a change in free energy  $F$ .

$$\begin{aligned} F &= U - T S \\ &= n E_v - K_B T \log \left[ \frac{N!}{(N-n)! n!} \right] \quad \text{-----(3)} \end{aligned}$$



According to Sterling's approximation,

$$\text{Log } x! = x \log x - x \text{ -----(4)}$$

Using eq (4) in eq (3), we get

$$\begin{aligned} F &= n E_v - K_B T [ N \log N - N - \{ (N - n) \log (N - n) - (N - n) \} - \{ n \log n - n \} ] \\ &= n E_v - K_B T [ N \log N - N - (N - n) \log (N - n) + N - n - n \log n + n ] \\ &= n E_v - K_B T [ N \log N - (N - n) \log (N - n) - n \log n ] \end{aligned}$$

Free energy in thermal equilibrium at constant volume must be minimum w.r.to change in n,

$$\begin{aligned} [\partial F / \partial n]_T = 0 &= E_v + K_B T [ - (N - n) \{ 1 / (N - n) \} - \log (N - n) + n (1/n) + \log n ] \\ &= E_v + K_B T [ - 1 - \log (N - n) + 1 + \log n ] \\ &= E_v - K_B T [ \log (N - n) - \log n ] \\ &= E_v - K_B T \log [ (N - n) / n ] \end{aligned}$$

$$\therefore E_v = K_B T \log [ (N - n) / n ]$$

$$E_v / K_B T = \log [ (N - n) / n ]$$

$$(N - n) / n = e^{E_v / K_B T}$$

$$n = (N - n) / e^{E_v / K_B T} = (N - n) e^{-(E_v / K_B T)}$$

If  $n \ll N$ , we can neglect n in  $(N - n)$ , so that

$$n \cong N e^{-(E_v / K_B T)} \text{ -----(5)}$$

Therefore n represents the number of vacancies created in the crystal.

If  $n E_v = 1 \text{ eV}$  and  $T = 1000\text{K}$ , then  $n/N = e^{-11.6} = 9.1 \times 10^{-6} \cong 10^{-5}$

The equilibrium concentration of vacancies decreases as the temperature decreases.

**Equilibrium Concentration Of Schottky defect:** In ionic crystals, the formation of paired vacancies is most favoured i.e., an equal number of positive and negative ion vacancies are produced. The formation of pairs makes it possible to keep the surface of the crystal electrostatically neutral.

The different ways in which n separated pairs can be formed are

$$P = [ N! / (N - n)! n! ]^2 \text{ -----(1)}$$



Increase in entropy is given by

$$S = K_B \log P$$

$$= K_B \log [N! / (N-n)! n!]^2 \text{ -----(2)}$$

Increase in entropy further produces a change in free energy F.

$$F = U - T S$$

$$= n E_P - K_B T \log [N! / (N-n)! n!]^2 \text{ -----(3)}$$

where  $E_P$  is the energy of formation of a pair

According to Sterling's approximation,

$$\log x! = x \log x - x \text{ -----(4)}$$

Using eq (4) in eq (3), we get

$$F = n E_P - 2 K_B T [ N \log N - N - \{ (N-n) \log (N-n) - (N-n) \} - \{ n \log n - n \}]$$

$$= n E_P - 2 K_B T [ N \log N - N - (N-n) \log (N-n) + N - n - n \log n + n ]$$

$$= n E_P - 2 K_B T [ N \log N - (N-n) \log (N-n) - n \log n ]$$

Free energy in thermal equilibrium at constant volume must be minimum w.r.to change in n,

$$[\partial F / \partial n]_T = 0 = E_P + 2K_B T [(N-n) \{-1 / (N-n)\} - \log (N-n) + n (1/n) + \log n]$$

$$= E_P + 2 K_B T [ -1 - \log (N-n) + 1 + \log n ]$$

$$= E_P - 2K_B T [ \log (N-n) - \log n ]$$

$$= E_P - 2K_B T \log [ (N-n) / n ]$$

$$\therefore E_P = 2 K_B T \log [ (N-n) / n ]$$

$$E_P / 2K_B T = \log [ (N-n) / n ]$$

$$(N-n) / n = e^{E_P / 2K_B T}$$

$$n = (N-n) / e^{E_P / 2K_B T} = (N-n) e^{-(E_P / 2K_B T)}$$

If  $n \ll N$ , we can neglect n in  $(N-n)$ , so that

$$n \cong N e^{-(E_P / 2K_B T)} \text{ -----(5)}$$

**Equilibrium Concentration Of Frenkel defects:**

Let in a perfect crystal,

$E_i$  be the energy required to displace an atom from a regular lattice site to an interstitial position

$N_i$  be the number of interstitial atoms

$N$  be the number of atoms

The total number of ways in which  $n$  Frenkel defects can be formed can be given by

$$P = [N! / (N-n)! n!] \times [N_i! / (N_i-n)! n!] \quad \text{-----(1)}$$

Since disorder increases due to the creation of Frenkel defects, the increase in entropy is given by

$$\begin{aligned} S &= K_B \log P \\ &= K_B \log \left[ \left\{ \frac{N!}{(N-n)! n!} \right\} \times \left\{ \frac{N_i!}{(N_i-n)! n!} \right\} \right] \quad \text{-----(2)} \end{aligned}$$

Increase in entropy further produces a change in free energy  $F$ .

$$\begin{aligned} F &= U - TS \\ &= E_i - K_B T \log \left[ \left\{ \frac{N!}{(N-n)! n!} \right\} \times \left\{ \frac{N_i!}{(N_i-n)! n!} \right\} \right] \quad \text{-----(3)} \end{aligned}$$

According to Sterling's approximation,

$$\log x! = x \log x - x \quad \text{-----(4)}$$

Using eq (4) in eq (3), we get

$$\begin{aligned} F &= E_i - K_B T \left[ N \log N - N - \{ (N-n) \log (N-n) - (N-n) \} - \{ n \log n - n \} + N_i \log N_i - N_i - \{ (N_i-n) \log (N_i-n) - (N_i-n) \} - \{ n \log n - n \} \right] \\ &= E_i - K_B T \left[ N \log N - N - (N-n) \log (N-n) - N + n - n \log n + n + N_i \log N_i - N_i - (N_i-n) \log (N_i-n) + N_i - n - n \log n + n \right] \\ &= E_i - K_B T \left[ N \log N - (N-n) \log (N-n) + N_i \log N_i - (N_i-n) \log (N_i-n) - 2n \log n \right] \end{aligned}$$

Free energy in thermal equilibrium at constant volume must be minimum w.r.to change in  $n$ ,

$$\left[ \frac{\partial F}{\partial n} \right]_T = 0 = E_i - K_B T \log \left[ \frac{(N-n)(N_i-n)}{n^2} \right]$$

$$= E_i - K_B T \log \left[ \frac{(N-n)(N_i-n)}{n^2} \right]$$

$$\therefore E_i = K_B T \log [ (N - n) (N_i - n) / n^2 ]$$

$$E_i / K_B T = \log [ (N - n) (N_i - n) / n^2 ]$$

If  $n \ll N$  and  $n \ll N_i$ ,

$$\text{then } E_i \cong K_B T \log (N N_i / n^2)$$

$$\text{Thus } E_i \cong K_B T [ \log (N N_i) - 2 \log n ]$$

$$\log n = \frac{1}{2} \log (N N_i) - E_i / 2K_B T$$

$$n = (N N_i)^{1/2} \exp ( - E_i / 2K_B T )$$

Therefore  $n$  should be proportional to  $(N N_i)^{1/2}$ .

**Line Imperfections:** If a plane of atoms lies only partway through a crystal, the edge of such a plane is a defect in the form of a line, and is known as dislocation. There are two types of dislocation ( 1 ) Edge dislocation and ( 2 ) Screw dislocation.

In a perfect crystal, atoms are arranged in both vertical and horizontal planes parallel to the side faces full length, but ends in between, within the crystal then it is called edge dislocation. Because of dislocation, just above the discontinuity, atoms are squeezed and are in a state of tension. The distorted configuration extends all along the edge into the crystal. Thus as the region of maximum distortion is centered around the edge of the incomplete plane, this distortion represents a line imperfection called an edge dislocation.

If the extra plane of atoms is from top of the crystal, this dislocation is called as positive dislocation and is represented by '  $\perp$  '. If the extra plane of atoms is from bottom of the crystal, this dislocation is called as negative dislocation and is represented by '  $\top$  '.

**Burgers Vector:** The magnitude and the direction of the displacement are defined by the vector called the Burgers vector. To determine the Burger vector, Burger circuit has to be constructed.

FIG.

Let us consider one perfect crystal and another crystal with edge dislocation. In the perfect crystal, starting from the point P, we go up by 6 steps, then move towards right by 5 steps, and move down by 6 steps and finally move towards left by 5 steps to reach the starting point P, the Burger circuit gets closed. When the same operation is performed on the dislocated crystal, we end up at Q instead of the starting point P. In order to close the Burger's circuit an

extra step **QP** has to be made. The magnitude and the direction of the step defines the Burgers vector. The Burgers vector is perpendicular to the edge dislocation line.

**Screw Dislocation:** Screw dislocation results from a displacement of the atoms in one part of a crystal relative to the rest of the crystal, forming a spiral ramp around the dislocation line.

FIG.

In screw dislocation, the Burger vector **b** is parallel to the dislocation line.

## UNIT – III

### 5.Elements Of Statistical Mechanics

**Introduction:** Statistical mechanics provides the mathematical language for understanding the nature of materials and applies to microstates and ultimately to arrive at the bulk property estimation. Statistical mechanics mainly deals with the distribution of identical, distinguishable and indistinguishable particles of a system in different states of the system.

**Phase space or hyper space or  $\mu$  - space:** Consider a system consisting of a large number of particles. The state of the particle at an instant can be represented with 3 position and 3 momentum coordinates. To specify the position and momentum of a particle in a system, a 6-dimensional space called phase space or hyper space or  $\mu$  - space is used. Any point in this space can be represented with 3 position coordinates  $x, y, z$  and the 3 momentum coordinates  $P_x, P_y, P_z$ . The space points in this space are called phase points or representative points. The space can be divided into large number of small elements called cells or groups. The volume of each element is  $dx, dy, dz, dp_x, dp_y, dp_z$  and is equal to  $h^3$ .

**Maxwell – Boltzman Distribution (Classical Statistics):** This distribution is applied to a macroscopic system consisting of a large number of identical but distinguishable particles such as gas molecules in a container. This distribution tells us the way of distribution of total energy  $E$  of the system among the various identical particles.

The main assumptions of Maxwell – Boltzman statistics are:

1. The particles are identical and distinguishable.
2. Any number of particles can occupy a single cell in phase space i.e., there is no limit on the number of particles which can occupy a phase space cell or an energy level .
3. The particles have any value of the spin i.e., any spin is possible.
4. Energy levels are continuous.

Consider a system consisting of  $n_1$  particles in  $E_1$  level,  $n_2$  particles in  $E_2$  level, .... ,  $n_i$  particles in  $E_i$  level ,etc.

The total number of particles in the system is constant

$$\text{ie.}, \sum n_i = N \quad \dots\dots\dots (1)$$

The total energy ( $E$ ) of the system is constant .

$$\text{ie.}, \sum n_i E_i = E \quad \dots\dots\dots (2)$$

Let  $g_1, g_2, g_3, \dots, g_i$  be the number of electron states called degeneracy parameter .

The probability of distribution of particles in different energy levels is given by

$$W = (N! g_i^{n_i}) / (n_1! n_2! \dots n_i!) \quad \dots\dots\dots (3)$$

Applying logarithm on both sides we get,

$$\log W = \log N! - (\log n_1! + \log n_2! + \dots + \log n_i!) + (n_1 \log g_1 + n_2 \log g_2 + \dots + n_i \log g_i)$$

Using Sterling's approximation ,  $\log x! = x \log x - x$

$$\log W = (N \log N - N) - \{(n_1 \log n_1 - n_1 + n_2 \log n_2 - n_2 + \dots + n_i \log n_i - n_i)\} + (n_1 \log g_1 + n_2 \log g_2 + \dots + n_i \log g_i)$$

Differentiating on both sides w.r.t  $n$  and  $N$  and  $g$  are constants

$$0 = - \{n_1 \frac{dn_1}{n_1} + \log n_1 \frac{dn_1}{n_1} + \dots + n_i \frac{dn_i}{n_i} + \log n_i \frac{dn_i}{n_i}\} + \{\log g_1 \frac{dn_1}{n_1} + \dots + \log g_i \frac{dn_i}{n_i}\}$$

$$0 = dn_1 (1 + \log n_1 - \log g_1) + dn_2 (1 + \log n_2 - \log g_2) + \dots + dn_i (1 + \log n_i - \log g_i) \dots \dots \dots (4)$$

We know that

$$n_1 + n_2 + \dots + n_i = N \dots \dots \dots (5)$$

$$dn_1 + dn_2 + \dots + dn_i = 0 \dots \dots \dots (6)$$

and also  $n_1 E_1 + n_2 E_2 + \dots + n_i E_i = E \dots \dots \dots (7)$

$$E_1 dn_1 + E_2 dn_2 + \dots + E_i dn_i = 0 \dots \dots \dots (8)$$

To solve equation (4) multiply equation (6) by  $\alpha$  and equation (8) by  $\beta$  and add to (4) where  $\alpha$  and  $\beta$  are constants known as Lagrangean multipliers.

**Bose Einstein Distribution:** The Bose Einstein Distribution deals with the distribution of identical indistinguishable particles like photons or phonons called Bosons. They do not obey Pauli's Principle.

The assumptions of Bose Einstein statistics are :

1. Particles are identical and indistinguishable.
2. There is no limit to the number of particles per state.
3. They have integral multiples of  $h/2\pi$ .
4. Energy states are discrete.

Consider a system consisting of  $N$  identical indistinguishable particles. Let  $n_1$  number of particles have each of energy  $E_1$  which has  $g_1$  states and  $n_2$  number of particles have each of energy  $E_2$  which has  $g_2$  states and so on. The  $g_i$  states will have  $(g_i - 1)$  partitions.

**Fermi-Dirac Distribution:** The Fermi-Dirac Distribution deals with the indistinguishable particles like electrons called Fermions. They obey Pauli's Principle (no two electrons in an atom have the same quantum state).

The assumptions of Bose Einstein statistics are :

1. Particles are identical and indistinguishable.
2. There is no limit to the number of particles per state.
3. They have integral multiples of  $h/2\pi$
4. Energy states are discrete.

**Black Body Radiation** : A body that completely absorbs all wavelengths of radiation incident on it at low temperatures or emits different wavelengths of radiation at higher temperatures is known as a black body.

A graph has been plotted between intensity versus wavelength of radiation from a black body. The temperature of the body is raised to different values and distribution curves are plotted for different temperatures.

From graph,

1. The intensity of radiation increases for each wavelength as the temperature of the body increases.
2. At any given temperature, the intensity of radiation from the body is maximum for a particular wavelength represented as  $\lambda_{1m}, \lambda_{2m}, \lambda_{3m}, \dots$ . This wavelength shifts towards shorter wavelength region with increase of temperature.
3. The area under the curve is proportional to the total radiation energy emitted by the body in unit time.

(a) Wien's Law: Wien showed that the maximum energy,  $E_m$  of the emitted radiation from black body is proportional to fifth power of absolute temperature ( $T^5$ ).

$$\text{i.e., } E_m \propto T^5 \quad \text{or} \quad E_m = \text{constant} \times T^5$$

Wien deduced the relation between the wavelength of emission and the temperature of the body as

$$U_\lambda d\lambda = (c_1 / \lambda^5) e^{-(c_2 / \lambda T)} d\lambda$$

$$= (8 \pi c h / \lambda^5) \{ 1 / [e^{(hc / \lambda K_B T)} - 1] \} d\lambda$$

Where  $U_\lambda d\lambda$  is the energy per unit volume in the wavelength range  $\lambda$  and  $\lambda+d\lambda$ . Here  $c_1$  and  $c_2$  are constants. Wien's law is valid at lower wavelength region, whereas it deviates from experimental values at higher wavelength regions.

(b) Rayleigh-Jeans Law: Rayleigh deduced an equation for the black body radiation based on the principle of equipartition of energy, each mode of vibration has assigned an average energy of  $K_B T$ . The number of vibrations per unit volume in the wavelength range  $\lambda$  and  $\lambda+d\lambda$  is given by  $8 \pi \lambda^{-4} d\lambda$ .

The vibration energy per unit volume in the range of  $\lambda$  and  $\lambda+d\lambda$  is

$$U_\lambda d\lambda = 8 \pi K_B T \lambda^{-4} d\lambda$$

This is Rayleigh-Jeans equation. This law correctly predicts the fall of intensity in the longer wavelength side. However, it fails to explain the lower wavelength side of the spectrum.

(c) Planck's Law: Planck assumed that the walls of the black body consists of a large number of electrical oscillators, vibrating with their own natural frequencies. An

oscillator possesses an energy equal to  $h\nu$  where  $h$  is Planck's constant and  $\nu$  is the frequency of the oscillator.

An oscillator may lose or gain energy by emitting or by absorbing photons respectively. Planck derived an equation for the energy per unit volume of black body in the entire spectrum of black body radiation and is given by

$$U_{\lambda} d\lambda = 8\pi hc / \lambda^5 \left\{ \left[ 1 / e^{(h\nu / K_B T)} \right] - 1 \right\} d\lambda$$

### Concept of Electron gas and Fermi Energy:

(a) Electron gas: A metal consists of immobile positive ions and free electrons. These free electrons are very large in metals. They move in random directions inside a metal like the gas molecules in a container. They are referred as free electron gas or electron gas.

When an electric field is applied on metals, the free electrons drift in a direction opposite to the applied field. They obey gas laws.

(b) Fermi Energy: The electron gas obey Fermi-Dirac distribution. Let  $g(E)$  be the density of electron states i.e., the number of available electron states per unit volume of metal in unit range of energies  $E$ .

Let the number of electron filled states be  $N(E)$  in  $g(E)$ .

Then the Fermi-Dirac distribution function  $F(E)$  is

$$F(E) = N(E) / g(E) = 1 / [ 1 + \exp ( E - E_F / K_B T ) ]$$

The distribution function  $F(E)$  is defined as the probability that an energy level  $E$  is occupied by an electron.

Suppose, if the level is empty then  $F(E) = 0$  or if the level is filled, then  $F(E) = 1$ .

In general the value of  $F(E)$  lies in between 0 and 1.

$$\begin{aligned} \text{At } 0K, F(E) &= 1 \quad \text{for } E < E_F \\ &= 0 \quad \text{for } E > E_F \end{aligned} \quad ] \dots\dots\dots(2)$$

This shows that all states below  $E_F$  are completely filled and all states above  $E_F$  are completely empty. As temperature increases, then  $F(E)$  decreases below  $E_F$ . At higher temperatures the curve passes through a point at which the probability of the electron being in the conduction or valence band is 0.5. The energy at which the probability of occupation is 0.5 at all temperatures is called Fermi energy. Alternatively, the highest energy possessed by an electron at absolute zero of temperature (0K) in a metal is called Fermi energy.



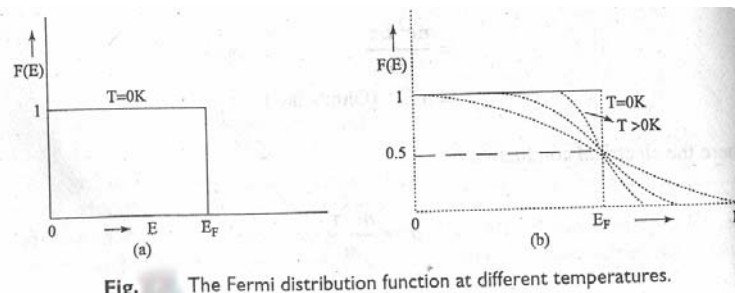

Fig. The Fermi distribution function at different temperatures.

**Density of States:** To calculate the carrier concentration i.e., the number of electrons per unit volume in a given energy range :

Let us consider the product of the density of states  $Z(E)$  and occupancy probability  $F(E)$

$$\text{i.e., } n_c = \int Z(E) F(E) dE \quad \dots\dots\dots(1)$$

The number of energy states with a particular value of  $E$  depends on how many combinations of quantum numbers result in the same value of  $n$  (degeneracy).

To calculate the number of energy states with all possible energies, with  $n$  as radius (where  $n^2 = n_1^2 + n_2^2 + n_3^2$ ) a sphere is constructed in 3-dimensional space and every point  $(n_1, n_2, n_3)$  within this space represents an energy state.

And also as every integer represents one energy state, unit volume of this space contains exactly one state. Hence the number of states in any volume is equal to the volume expressed in units of cubes of lattice parameters.

$\therefore$  The number of energy states within a sphere of radius  $n = (4/3) \pi n^3$

Since  $n_1, n_2, n_3$  can have only positive integer values, we have to consider only one octant of the sphere.

Hence available energy states =  $(1/8) (4 \pi n^3 / 3)$

In order to calculate the number of states within a small energy interval  $E$  and  $E+dE$ , we have to construct two spheres with radii  $n$  and  $(n+dn)$  and calculate the space occupied within these two spheres.

Thus the number of energy states having energy values between  $E$  and  $E+dE$  is given by

$$Z(E) dE = (1/8) (4 \pi / 3) (n+dn)^3 - (1/8) (4 \pi n^3 / 3)$$

$$= (\pi n^2 / 2) dn \quad \dots\dots\dots(2) \quad (\text{neglecting higher powers of } dn \text{ as it is very small})$$

The expression for the energy of electron is given by

$$E = n^2 h^2 / 8 m L^2$$

$$n^2 = 8 m L^2 E / h^2$$

$$n = [8 m L^2 E / h^2]^{1/2} \dots\dots\dots(3)$$

Differentiating  $n^2$ , we get

$$2n dn = 8 m L^2 dE / h^2 \dots\dots\dots(4)$$

$$dn = 8 m L^2 dE / 2n h^2$$

$$= (8 m L^2 / h^2) (1/2) (h^2 / 8 m L^2)^{1/2} (dE / E^{1/2})$$

$$= (1/2) (8 m L^2 / h^2)^{1/2} (dE / E^{1/2})$$

.....(5)

Substituting the values of  $n^2$  and  $dn$  in eq (2), we get

$$Z(E) dE = (\pi / 2) (8 m L^2 E / h^2) (1/2) [8 m L^2 / h^2]^{1/2} (dE / E^{1/2})$$

$$= (\pi / 4) (8 m L^2 / h^2)^{3/2} E^{1/2} dE$$

According to Pauli's exclusion principle two electrons of opposite spin can occupy each state and hence the number of energy states available for electron occupancy is given by

$$Z(E) dE = 2 \times (\pi / 4) (8 m L^2 / h^2)^{3/2} E^{1/2} dE$$

$$= (4 \pi / h^3) (2 m)^{3/2} L^3 E^{1/2} dE \dots\dots\dots(6)$$

Density of energy states is given by number of energy states per unit volume

$$\text{i.e, density of states} = Z(E) dE = (4 \pi / h^3) (2 m)^{3/2} E^{1/2} dE$$

.....(7)

Free electron density in metals:

Substituting the values  $F(E)$  and  $Z(E)$  in eq(1) for calculation of electron density,

$$n_c = \int Z(E) F(E) dE$$

$$= (4 \pi / h^3) (2 m)^{3/2} \int E^{1/2} \{1 / [1 + \exp (E - E_F / K_B T)]\}$$

$dE$  .....(8)

This is the expression for free carriers ie, electron density at any temperature. This can be used to calculate the free electron density in metals and carrier concentration in semiconductors.

## 6. PRINCIPLES OF QUANTUM MECHANICS

**Introduction:** Quantum mechanics is a new branch of study in physics which is indispensable in understanding the mechanics of particles in the atomic and sub-atomic scale.

The motion of macro particles can be observed either directly or through microscope. Classical mechanics can be applied to explain their motion. But classical mechanics failed to explain the motion of micro particles like electrons, protons etc...

Max Plank proposed the Quantum theory to explain Blackbody radiation. Einstein applied it to explain the Photo Electric Effect. In the mean time, Einstein's mass – energy relationship ( $E = mc^2$ ) had been verified in which the radiation and mass were mutually convertible. Louis deBroglie extended the idea of dual nature of radiation to matter, when he proposed that matter possesses wave as well as particle characteristics.

The classical mechanics and the quantum mechanics have fundamentally different approaches to solve problems. In the case of classical mechanics it is unconditionally accepted that position, mass, velocity, acceleration etc of a particle can be measured accurately, which, of course, true in day to day observations. In contrast, the structure of quantum mechanics is built upon the foundation of principles which are purely probabilistic in nature. As per the fundamental assumption of quantum mechanics, it is impossible to measure simultaneously the position and momentum of a particle, whereas in the case of classical mechanics, there is nothing which contradicts the measurements of both of them accurately.

### Plank's Quantum Theory:

Max Plank, a German physicist derived an equation which successfully accounted for the spectrum of the blackbody radiation. He incorporated a new idea in his deduction of Plank eqn. that the probability of emission of radiation decreases as its frequency increases so that, the curve slopes down in the high frequency region. The oscillators in the blackbody can have only a discrete set of energy values. Such an assumption was radically different from the basic principles of physics.

The assumption in the derivation of Plank's law is that the wall of the experimental blackbody consists of a very large number of electrical oscillators, with each oscillator vibrating with a frequency of its own. Plank brought two special conditions in his theory. They are

- (1) Only an integral multiple of energies  $h \nu$  where 'h' is Plank's constant and ' $\nu$ ' is frequency of vibration i.e, the allowed energy values are  $E = n h \nu$  where  $n = 0, 1, 2, \dots$
- (2) An oscillator may lose or gain energy by emitting or absorbing radiation of frequency  $\nu = (\Delta E / h)$ , where  $\Delta E$  is the difference in the values of energies of the oscillator before and the emission or absorption had taken place.

Based on the above ideas, he derived the law governing the entire spectrum of the Blackbody radiation, given by

$$U_{\lambda} d\lambda = (8\pi hc / \lambda^5) [1 / (e^{h\nu/kT} - 1)] d\lambda \quad (\text{since } \nu = c / \lambda)$$

This is called Plank's radiation law.

**Waves and Particles:** deBroglie suggested that the radiation has dual nature i.e both particle as well as wave nature. The concept of particle is easy to grasp. It has mass, velocity, momentum and energy. The concept of wave is a bit more difficult than that of a particle. A wave is spread out over a relatively large region of space, it cannot be said to be located just here and there, and it is hard to think of mass being associated with a wave. A wave is specified by its frequency, wavelength, phase, amplitude, intensity.

Considering the above facts, it appears difficult to accept the conflicting ideas that radiation has dual nature. However this acceptance is essential because radiation sometimes behaves as a wave and at other times as a particle.

- (1) Radiations behaves as waves in experiments based on interference, diffraction, polarization etc. this is due to the fact that these phenomena require the presence of two waves at the same position and at the same time. Thus we conclude that radiation behaves like wave.
- (2) Plank's quantum theory was successful in explaining blackbody radiation, photoelectric effect, Compton Effect and had established that the radiant energy, in its interaction with the matter, behaves as though it consists of corpuscles. Here radiation interacts with matter in the form of photons or quanta. Thus radiation behaves like particle.

Hence radiation cannot exhibit both particle and wave nature simultaneously.

**deBroglie hypothesis :** The dual nature of light possessing both wave and particle properties was explained by combining Plank's expression for the energy of a photon  $E = h\nu$  with Einstein's mass energy relation  $E = mc^2$  (where  $c$  is velocity of light,  $h$  is Plank's constant,  $m$  is mass of particle)

$$\Rightarrow h\nu = mc^2$$

Introducing  $\nu = c / \lambda$ , we get  $hc / \lambda = mc^2$

$$\Rightarrow \lambda = h / mc = h / p \quad \text{where } p \text{ is momentum of particle}$$

$\lambda$  is deBroglie wavelength associated with a photon.

deBroglie proposed the concept of matter waves, according to which a material particle of mass ' $m$ ' moving with velocity ' $v$ ' should be associated with deBroglie wavelength ' $\lambda$ ' given by

$$\lambda = h / mv = h / p$$

The above eqn. represents deBroglie wave eqn.

### Characteristics of Matter waves:

$$\text{Since } \lambda = h / m v$$

1. Lighter the particle, greater is the wavelength associated with it.
2. Lesser the velocity of the particle, longer the wavelength associated with it.
3. For  $v = 0$ ,  $\lambda = \infty$ . This means that only with moving particle, matter waves is associated.
4. Whether the particle is changed or not, matter waves is associated with it.
5. It can be proved that matter waves travel faster than light.

$$\text{We know that } E = h v \text{ and } E = m c^2$$

$$\Rightarrow h v = m c^2 \text{ or } v = m c^2 / h$$

Wave velocity ( $\omega$ ) is given by

$$\omega = v \lambda = m c^2 \lambda / h = (m c^2 / h) (h / m v)$$

$$\Rightarrow \omega = c^2 / v$$

As the particle velocity 'v' cannot exceed velocity of light,  $\omega$  is greater than the velocity of light.

6. No single phenomena exhibit both particle nature and wave nature simultaneously.
7. The wave nature of matter introduces an uncertainty in the location of the particle & the momentum of the particle exists when both are determined simultaneously.

### Davisson and Germer's experiment:

C. J. Davisson and L. H. Germer were studying scattering of electrons by a metal target and measuring the intensity of electrons scattered in different directions.

#### Experimental Arrangement:

An electron gun, which comprises of a tungsten filament is heated by a low tension battery B1, produces electrons. These electrons are accelerated to desired velocity by applying suitable potential from a high tension source B2. The accelerated electrons are collimated into a fine beam by allowing them to pass through a system of pin holes provided in the cylinder. The whole instrument is kept in an evacuated chamber.

The past moving beam of electrons is made to strike the Nickel target capable of rotating about an axis perpendicular to the plane. The electrons are now scattered in all directions by the atomic planes of crystals. The intensity of the electron beam scattered in a direction can be measured by the electron collector which can be rotated about the same axis

as the target. The collector is connected to a galvanometer whose deflection is proportional to the intensity of the electron beam entering the collector.

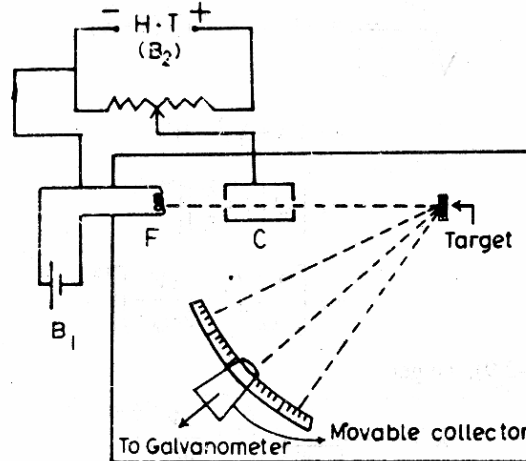

Fig. Davisson and Germer's Apparatus

The electron beam is accelerated by 54 V is made to strike the Nickel crystal and a sharp maximum is occurred at angle of  $50^\circ$  with the incident beam. The incident beam and the diffracted beam in this experiment make an angle of  $65^\circ$  with the family of Bragg's planes.

$$d = 0.091 \text{ nm} \quad (\text{for Ni crystals})$$

According to Bragg's law for maxima in diffracted pattern,

$$2d \sin \theta = n \lambda$$

$$\text{For } n = 1, \quad \lambda = 2d \sin \theta$$

$$= 2 \times 0.091 \times 10^{-10} \times \sin 65^\circ$$

$$= 0.165 \text{ nm}$$

For a 54 V electron, the deBroglie wavelength associated with the electron is given by

$$= 12.25 / \sqrt{V} = (12.25 / \sqrt{54}) \text{ \AA}$$

$$= 0.166 \text{ nm.}$$

This value is in agreement with the experimental value. This experiment provides a direct verification of deBroglie hypothesis of wave nature of moving particles.

### G.P. Thomson's Experiment:

G.P. Thomson investigated high speed electrons produced by applying the high voltage ranges from 10 to 50 kV. The principle is similar too that of that of powdered crystal method of X-ray diffraction.

In this experiment, an extremely thin ( $10^{-8} \text{ m}$ ) metallic film F of gold, aluminium etc., is used as a transmission grating to a narrow beam of high speed electrons emitted by a cathode

C and accelerated by anode A. A fluorescent screen S or a suitable photographic plate P is used to observe the scattered electron beam. The whole arrangement is enclosed in a vacuum chamber.

The electron beam transmitted through the metal foil gets scattered producing diffraction pattern consisting of concentric circular rings around a central spot. The experimental results and its analysis are similar to those of powdered crystal experiment of X-ray diffraction.

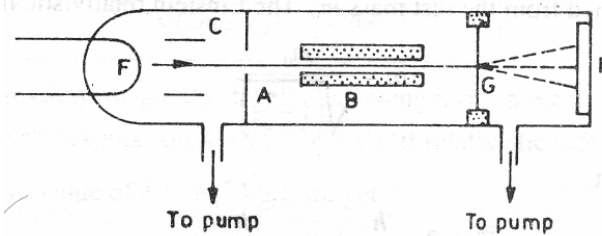
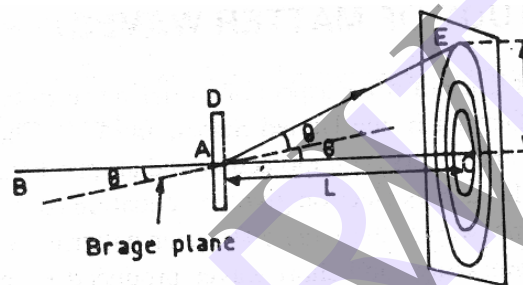

Fig. Thomson Apparatus



L: distance between the foil and screen  
 R(r): radius of the diffraction ring  
 $\theta$ : glancing angle

The method of interpretation of the experimental results is same as that of the Davisson and Germer experiment. Here also we use Bragg's law and deBroglie wavelength.

We have  $2d \sin \theta = n \lambda$

$$\theta = n \lambda / 2d \quad \rightarrow \text{I} \quad \text{since } \theta \text{ is small } \sin \theta = \theta$$

From fig.

$$R/L = \tan 2\theta \approx 2\theta$$

$$R = L 2\theta \rightarrow \text{II}$$

From eqn I, II

$$R = L 2 n \lambda / 2d = L n \lambda / d$$

Since L and d are fixed in the experiment



$$R \propto n\lambda \text{ or } D \propto n\lambda \quad D \text{ is diameter of the ring}$$

Combining with the deBroglie expression

$$\lambda = \sqrt{150 / V (1+r)}$$

Where (1+r) is the relativistic correction we notice that  $D\sqrt{V(1+r)}$  must be constant for a given order the experiment repeated with different voltages. The data shows that  $D\sqrt{V(1+r)}$  is constant, thus supporting the deBroglie concept of matter waves.

### Heisenberg Uncertainty Principle:

According to classical mechanics, a moving particle at any instant has a fixed position in space and a definite momentum which can be determined simultaneously with any desired accuracy. The classical point of view represents an approximation which is adequate for the objects of appreciable size, but not for the particles of atomic dimensions.

Since a moving particle has to be regarded as a deBroglie group, there is a limit to the accuracy with which we can measure the particle properties. The particle may be found anywhere within the wave group, moving with the group velocity. If the group is narrow, it is easy to locate its position but the uncertainty in calculating its velocity or momentum increases. On the other hand, if the group is wide, its momentum can be estimated satisfactorily, but the uncertainty in finding the location of the particle is great. Heisenberg stated that the simultaneous determination of exact position and momentum of a moving particle is impossible.

If  $\Delta x$  is Error in the measurement of position of the particle along X-axis

$\Delta p$  is Error in the measurement of momentum

Then  $\Delta x \cdot \Delta p = h$  ----- (1) where h is Plank's constant

The above relation represents the uncertainty involved in measurement of both the position and momentum of the particle.

To optimize the above error, lower limit is applied to the eqn. (1)

$$\text{Then } (\Delta x) \cdot (\Delta p) \geq \hbar / 2 \text{ where } \hbar = h / 2 \Pi$$

A particle can be exactly located ( $\Delta x \rightarrow 0$ ) only at the expense of an infinite momentum ( $\Delta p \rightarrow \infty$ ).

There are uncertainty relations between position and momentum, energy and time, and angular momentum and angle.

If the time during which a system occupies a certain state is not greater than  $\Delta t$ , then the energy of the state cannot be known within  $\Delta E$ ,

$$\text{i e } (\Delta E) (\Delta t) \geq \hbar / 2 .$$



## Schrödinger's Time Independent Wave Equation:

Schrödinger, in 1926, developed wave equation for the moving particles. One of its forms can be derived by simply incorporating the deBroglie wavelength expression into the classical wave eqn.

If a particle of mass 'm' moving with velocity 'v' is associated with a group of waves.

Let  $\psi$  be the wave function of the particle. Also let us consider a simple form of progressing wave like the one represented by the following equation,

$$\Psi = \Psi_0 \sin (\omega t - k x) \text{ ----- (1)}$$

Where  $\Psi = \Psi (x, t)$  and  $\Psi_0$  is the amplitude.

Differentiating  $\Psi$  partially w.r.to x,

$$\begin{aligned} \partial \Psi / \partial x &= \Psi_0 \cos (\omega t - k x) (-k) \\ &= -k \Psi_0 \cos (\omega t - k x) \end{aligned}$$

Once again differentiate w.r.to x

$$\begin{aligned} \partial^2 \psi / \partial x^2 &= (-k) \Psi_0 (-\sin (\omega t - k x)) (-k) \\ &= -k^2 \Psi_0 \sin (\omega t - k x) \end{aligned}$$

$$\partial^2 \psi / \partial x^2 = -k^2 \psi \text{ (from eqn (1))}$$

$$\partial^2 \psi / \partial x^2 + k^2 \psi = 0 \text{ ----- (2)}$$

$$\partial^2 \psi / \partial x^2 + (4 \Pi^2 / \lambda^2) \psi = 0 \text{ ----- (3) (since } k = 2 \Pi / \lambda)$$

From eqn. (2) or eqn. (3) is the differential form of the classical wave eqn. now we incorporate deBroglie wavelength expression  $\lambda = h / m v$ .

Thus we obtain

$$\partial^2 \psi / \partial x^2 + (4 \Pi^2 / (h / m v)^2) \psi = 0$$

$$\partial^2 \psi / \partial x^2 + 4 \Pi^2 m^2 v^2 \psi / h^2 = 0 \text{ ----- (4)}$$

The total energy E of the particle is the sum of its kinetic energy K and potential energy V

$$\text{i e } E = K + V \text{ ----- (5)}$$

$$\text{And } K = mv^2/2 \text{ ----- (6)}$$

$$\text{Therefore } m^2 v^2 = 2 m (E - V) \text{ ----- (7)}$$

From (4) and (7)

$$\Rightarrow \partial^2 \psi / \partial x^2 + [8\pi^2 m (E-V) / h^2] \psi = 0 \text{ ----- (8)}$$

In quantum mechanics, the value  $h / 2 \pi$  occurs more frequently. Hence we denote,

$$\hbar = h / 2 \pi$$

Using this notation, we have

$$\partial^2 \psi / \partial x^2 + [2 m (E - V) / \hbar^2] \psi = 0 \text{ ----- (9)}$$

For simplicity, we considered only one – dimensional wave. Extending eqn. (9) for a three – dimensional, we have

$$\partial^2 \psi / \partial x^2 + \partial^2 \psi / \partial y^2 + \partial^2 \psi / \partial z^2 + [2 m (E - V) / \hbar^2] \psi = 0 \text{ ----- (10)}$$

$$\text{Where } \Psi = \Psi (x, y, z).$$

Here, we have considered only stationary states of  $\psi$  after separating the time dependence of  $\Psi$ .

Using the Laplacian operator,

$$\nabla^2 = \partial^2 / \partial x^2 + \partial^2 / \partial y^2 + \partial^2 / \partial z^2 \text{ ----- (11)}$$

Eqn. (10) can be written as

$$\nabla^2 \Psi + [2 m (E - V) / \hbar^2] \Psi = 0 \text{ ----- (12)}$$

This is the Schrödinger Time Independent Wave Equation.

### Physical Significance of Wave Function:

Max Born in 1926 gave a satisfactory interpretation of the wave function  $\psi$  associated with a moving particle. He postulated that the square of the magnitude of the wave function  $|\psi|^2$  (or  $\psi \psi^*$  if  $\psi$  is complex), evaluated at a particular point represents the probability of finding the particle at the point.  $|\psi|^2$  is called the probability density and  $\psi$  is the probability amplitude. Thus the probability of the particle within an element volume  $d\tau$  is  $|\psi|^2 d\tau$ . Since the particle is certainly somewhere, the integral of  $|\psi|^2 d\tau$  over all space must be unity i.e.

$$\int_{-\infty}^{\infty} |\psi|^2 d\tau = 1 \text{ ----- (28)}$$

A wave function that obeys the above equations is said to be normalized. Energy acceptable wave function must be normalizable besides being normalizable; an acceptable wave function should fulfill the following requirements (limitations)

1. It must be finite everywhere.
2. It must be single valued.
3. It must be continuous and have a continuous first derivative everywhere.

### Normalization Of a wave function:

Since  $|\psi(x, y, z)|^2 \cdot dv$  is the probability that the particle will be found in a volume element  $dv$ . Surrounding the point at position  $(x, y, z)$ , the total probability that the particle will be somewhere in space must be equal to 1. Thus, we have

$$\int_{-\infty}^{\infty} |\psi(x, y, z)|^2 \cdot dv = 1$$

Where  $\psi$  is a function of the space coordinates  $(x, y, z)$  from this 'normalization condition' we can find the value of the constant and its sign. A wave function which satisfies the above condition is said to be normalized (to unity).

The normalizing condition for the wave function for the motion of a particle in one dimension is

$$\int_{-\infty}^{\infty} |\psi(x)|^2 \cdot dx = 1$$

From these equations, we see that for one – dimensional case, the dimension of  $\psi(x)$  is  $L^{-1/2}$  and for the three – dimensional case the dimension of  $\psi(x, y, z)$  is  $L^{-3/2}$ .

### Particle in One Dimensional Potential Box:

Consider a particle of mass 'm' placed inside a one-dimensional box of infinite height and width L.

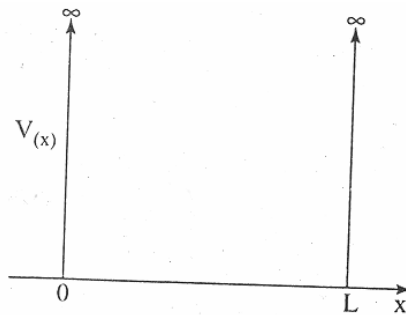

Fig. Particle in a potential well of infinite height.

Assume that the particle is freely moving inside the box. The motion of the particle is restricted by the walls of the box. The particle is bouncing back and forth between the walls of the box at  $x = 0$  and  $x = a$ . For a freely moving particle at the bottom of the potential well, the potential energy is very low. Since the potential energy is very low, moving particle energy is assumed to be zero between  $x = 0$  and  $x = a$ .

The potential energy of the particle outside the walls is infinite due to the infinite P.E outside the potential well.

The particle cannot escape from the box

$$\text{i.e. } V = 0 \text{ for } 0 < x < a$$

$$V = \infty \text{ for } 0 \geq x \geq a$$

Since the particle cannot be present outside the box, its wave function is zero

$$\text{i.e. } |\psi|^2 = 0 \text{ for } 0 > x > a$$

$$|\psi|^2 = 0 \text{ for } x = a \text{ \& } x = 0$$

The Schrödinger one – dimensional time independent eqn. is

$$\nabla^2 \Psi + [2m(E - V) / \hbar^2] \Psi = 0 \text{ -----(1)}$$

For freely moving particle  $V = 0$

$$\nabla^2 \Psi + [2mE / \hbar^2] \Psi = 0 \text{ -----(2)}$$

$$\text{Taking } 2mE / \hbar^2 = K^2 \text{ ----- (3)}$$

$$\text{Eqn.(1) becomes } \partial^2 \psi / \partial x^2 + k^2 \Psi = 0 \text{ -----(4)}$$

Eqn. (1) is similar to eq. of harmonic motion and the solution of above eqn. is written as

$\Psi = A \sin kx + B \cos kx$  ----- (5) where A, B and k are unknown quantities and to calculate them it is necessary to construct boundary conditions.

Hence boundary conditions are

$$\text{When } x = 0, \Psi = 0 \Rightarrow \text{from (5) } 0 = 0 + B \Rightarrow B = 0 \text{ ----- (6)}$$

$$\text{When } x = a, \Psi = 0 \Rightarrow \text{from (5) } 0 = A \sin ka + B \cos ka \text{ ----- (7)}$$

But from (6)  $B = 0$  therefore eqn. (7) may turn as

$$A \sin ka = 0$$

Since the electron is present in the box  $a \neq 0$

$$\sin ka = 0$$

$$ka = n\pi$$

$$k = n\pi / a \quad \text{----- (8)}$$

Substituting the value of  $k$  in eqn. (3)

$$2mE / \hbar^2 = (n\pi / a)^2$$

$$E = (n\pi / a)^2 (\hbar^2 / 2m) = (n\pi / a)^2 (h^2 / 8m\pi^2)$$

$$E = n^2 h^2 / 8ma^2$$

In general  $E_n = n^2 h^2 / 8ma^2$  -----(9)

The wave eqn. can be written as

$$\Psi = A \sin(n\pi x / a) \quad \text{----- (10)}$$

Let us find the value of  $A$ , if an electron is definitely present inside the box, then

$$\Rightarrow \int_{-\infty}^{\infty} |\psi|^2 dx = 1$$

$$\Rightarrow \int_0^a A^2 \sin^2(n\pi x / a) dx = 1$$

$$\Rightarrow \int_0^a \sin^2(n\pi x / a) dx = 1 / A^2$$

$$\Rightarrow \int_0^a [1 - \cos(2\pi n(x/a)) / 2] dx = 1 / A^2$$

$$A = \sqrt{2} / a \quad \text{----- (11)}$$

From eqn's. (10) & (11)

$$\Psi_n = \sqrt{2} / a \sin(n\pi x / a) \quad \text{----- (12)}$$

Eqn. (9) represents an energy level for each value of  $n$ . the wave function this energy level is given in eqn. (12). Therefore the particle in the box can have discrete values of energies. These values are quantized. Not that the particle cannot have zero energy. The normalized wave functions  $\Psi_1, \Psi_2, \Psi_3$  given by eqn (12) is plotted. the values corresponding to each  $E_n$  value is known as Eigen value and the corresponding wave function is known as Eigen function.

The wave function  $\Psi_1$ , has two nodes at  $x = 0$  &  $x = a$

The wave function  $\Psi_2$ , has three nodes at  $x = 0, x = a/2$  &  $x = a$

The wave function  $\Psi_3$ , has three nodes at  $x = 0, x = a/3, x = 2a/3$  & at  $x = a$

The wave function  $\Psi_n$ , has  $(n + 1)$  nodes

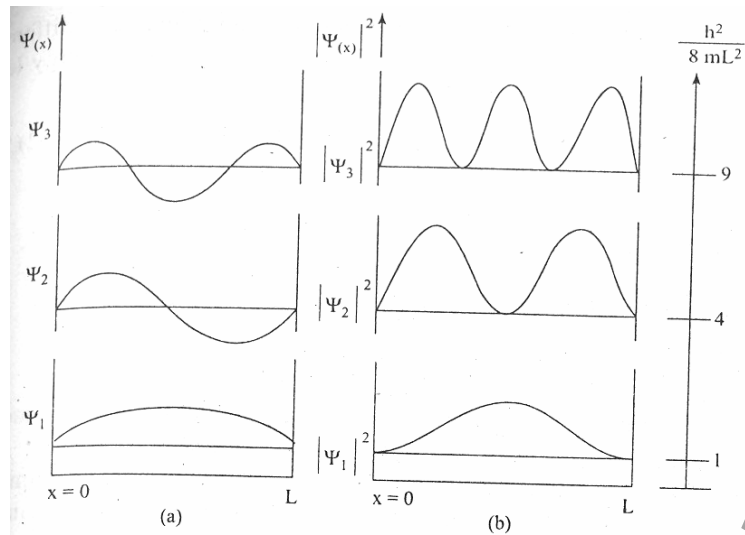

Substituting the value of E in (3), we get

$$(2m / \hbar^2) (p^2 / 2m) = k^2$$

$$\Rightarrow p^2 / \hbar^2 = k^2$$

$$k = p / \hbar = p / (h / 2\pi) = 2\pi p / h$$

$$k = 2\pi / \lambda \quad \text{where } k \text{ is known as wave vector.}$$

### Questions:

1. What are the matter waves? Explain their properties.
2. Explain de Broglie hypothesis.
3. Explain the duality of matter waves
4. Describe Davisson and Germer's experiment and explain how it enabled the verification of the de Broglie equation.
5. Explain G.P. Thompson's experiment in support of de Broglie hypothesis
6. Explain Heisenberg's uncertainty principle. Give its physical significance.
7. Derive time independent one dimensional Schrödinger's equation.
8. Explain the physical significance of wave function.
9. Write down Schrödinger's wave equation for a particle in one dimensional potential box.

## UNIT – IV

### 7. BAND THEORY OF SOLIDS

**Bloch Theorem:** A crystalline solid consists of a lattice which is composed of a large number of ionic cores at regular intervals, and, the conduction electrons can move freely throughout the lattice.

Let the lattice is in only one-dimension ie only an array of ionic cores along x-axis is considered. If we plot the potential energy  $V$  of a conduction electron as a function of its position in the lattice, the variation of potential energy.

Since the potential energy of any body bound in a field of attraction is negative, and since the conduction electron is bound to the solid, its potential energy  $V$  is negative.

Further, as it approaches the site of an ionic core  $V \rightarrow -\infty$ . Since this occurs symmetrically on either side of the core, it is referred to as potential well. The width of the potential well  $b$  is not uniform, but has a tapering shape.

If  $V_0$  is the potential at a given depth of the well, then the variation is such that

$$b \rightarrow 0, \quad \text{as } V_0 \rightarrow \infty, \quad \text{and,} \\ \text{The product } b V_0 \text{ is a constant.}$$

Now, since the lattice is a repetitive structure of the ion arrangement in a crystal, the type of variation of  $V$  also repeats itself. If  $a$  is the interionic distance, then, as we move in  $x$ -direction, the value of  $V$  will be same at all points which are separated by a distance equal to  $a$ .

$$\text{ie } V(x) = V(x + a) \quad \text{where, } x \text{ is distance of the electron from the core.}$$

Such a potential is said to be a periodic potential.

The Bloch's theorem states that, for a particle moving in a periodic potential, the Eigen functions for a conduction electron are of the form,

$$\chi(x) = U(x) \cos kx$$

$$\text{Where } U(x) = U(x + a)$$

The Eigen functions are the plane waves modulated by the function  $U(x)$ . The function  $U(x)$  has the same periodicity as the potential energy of the electron, and is called the modulating function.

In order to understand the physical properties of the system, it is required to solve the Schrödinger's equation. However, it is extremely difficult to solve the Schrödinger's equation with periodic potential described above. Hence the Kronig – Penney Model is adopted for simplification.

#### THE KRONIG -PENNEY MODEL:

It is assumed in quantum free electron theory of metals that the free electrons in a metal express a constant potential and is free to move in the metal. This theory explains successfully most of the phenomena of solids. But it could not explain why some solids are good conductors and some other are insulators and semi conductors. It can be understood successfully using the band theory of solids.

According to this theory, the electrons move in a periodic potential produced by the positive ion cores. The potential of electron varies periodically with periodicity of ion core and potential energy of the electrons is zero near nucleus of the positive ion core. It is maximum when it is lying between the adjacent nuclei which are separated by interatomic spacing. The variation of potential of electrons while it is moving through ion core is shown fig.

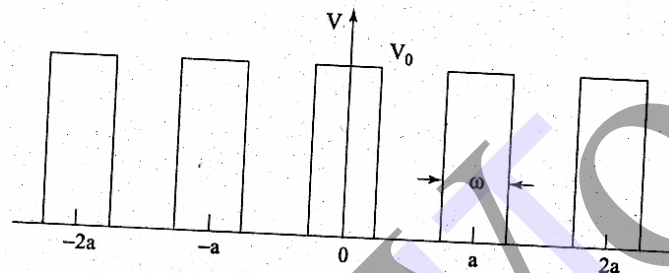

Fig. One dimensional periodic potential

$$V(x) = \begin{cases} 0, & \text{for the region } 0 < x < a \\ V_0 & \text{for the region } -b < x < a \end{cases} \text{-----(1)}$$

Applying the time independent Schrödinger's wave equation for above two regions

$$d^2\Psi / dx^2 + 2mE\Psi / \hbar^2 = 0 \quad \text{for region } 0 < x < a \quad \text{-----(2)}$$

$$\text{and } d^2\Psi / dx^2 + 2m(E - V)\Psi / \hbar^2 = 0 \quad \text{for region } -b < x < a \quad \text{-----(3)}$$

$$\text{Substituting } \alpha^2 = 2mE / \hbar^2 \quad \text{-----(4)}$$

$$\beta^2 = 2m(E - V) / \hbar^2 \quad \text{-----(5)}$$

$$d^2\Psi / dx^2 + \alpha^2 \Psi = 0 \quad \text{for region } 0 < x < a \quad \text{-----(6)}$$

$$d^2\Psi / dx^2 + \beta^2 \Psi = 0 \quad \text{for region } -b < x < a \quad \text{-----(7)}$$

The solution for the eqn.s (6) and (7) can be written as

$$\Psi(x) = U_k(x) e^{ikx} \quad \text{-----(8)}$$

The above solution consists of a plane wave  $e^{ikx}$  modulated by the periodic function.

$U_k(x)$ , where this  $U_k(x)$  has the periodicity of the ion such that

$$U_k(x) = U_k(x+a) \quad \text{-----(9)}$$



and where  $k$  is propagating vector along  $x$ -direction and is given by  $k = 2\pi/\lambda$ . This  $k$  is also known as wave vector.

Differentiating equation (8) twice with respect to  $x$ , and substituting in equation (6) and (7), two independent second order linear differential equations can be obtained for the regions  $0 < x < a$  and  $-b < x < 0$ .

Applying the boundary conditions to the solution of above equations, for linear equations in terms of  $A, B, C$  and  $D$  it can be obtained (where  $A, B, C, D$  are constants) the solution for these equations can be determined only if the determinant of the coefficients of  $A, B, C$ , and  $D$  vanishes, on solving the determinant.

$$(\beta^2 - \alpha^2 / 2 \alpha \beta) \sin \hbar \beta b \sin \alpha a + \cos \hbar \beta b \cos \alpha a = \cos k (a + b) \text{ ----- (10)}$$

The above equation is complicated and Kronig and Penney could conclude with the equation. Hence they tried to modify this equation as follows

Let  $V_0$  is tending to infinite and  $b$  is approaching to zero. Such that  $V_0 b$  remains finite. Therefore  $\sin \hbar \beta b \rightarrow \beta b$  and  $\cos \hbar \beta b \rightarrow 1$

$$\begin{aligned} \beta^2 - \alpha^2 &= (2m/\hbar^2)(V_0 - E) - (2mE/\hbar^2) \\ &= (2m/\hbar^2)(V_0 - E - E) = (2m/\hbar^2)(V_0 - 2E) \\ &= 2mV_0/\hbar^2 \quad (\text{since } V_0 \gg E) \end{aligned}$$

Substituting all these values in equation (10) it verifies as

$$\begin{aligned} (2mV_0/2\hbar^2\alpha\beta)\beta b \cdot \sin \alpha a + \cos \alpha a &= \cos ka \\ (mV_0ba/\hbar^2)(\sin \alpha a/\alpha a) + \cos \alpha a &= \cos ka \\ (P/\alpha a) \sin \alpha a + \cos \alpha a &= \cos ka \text{ ----- (11)} \end{aligned}$$

$$\text{Where } P = [mV_0ba/\hbar^2] \text{ ----- (12)}$$

and is a measure of potential barrier strength.

The left hand side of the equation (11) is plotted as a function of  $\alpha$  for the value of  $P = 3\pi/2$  which is shown in fig, the right hand side one takes values between  $-1$  to  $+1$  as indicated by the horizontal lines in fig. Therefore the equation (11) is satisfied only for those values of  $ka$  for which left hand side between  $\pm 1$ .

From fig, the following conclusions are drawn.

- 1) The energy spectrum of the electron consists of a number of allowed and forbidden energy bands.
- 2) The width of the allowed energy band increases with increase of energy values i.e. increasing the values of  $\alpha a$ . This is because the first term of equation (11) decreases with increase of  $\alpha a$ .

$$(P/\alpha a) \sin \alpha a + \cos \alpha a = 3\pi/2$$

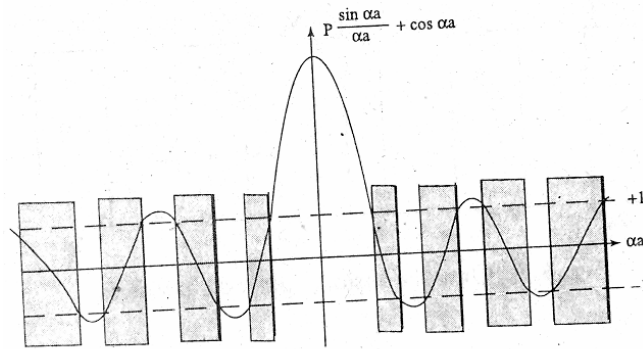

Fig Plot of  $P \frac{\sin \alpha a}{\alpha a} + \cos \alpha a$  versus  $\alpha a$ .

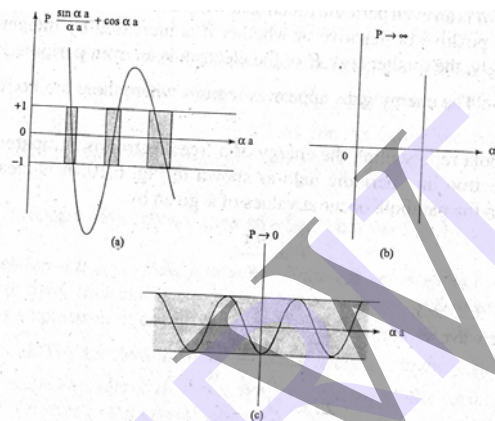

Fig. a)  $P=6\pi$  b)  $P \rightarrow \infty$  c)  $P \rightarrow 0$

- 3) With increasing  $P$ , ie with increasing potential barrier, the width of an allowed band decreases. As  $P \rightarrow \infty$ , the allowed energy becomes infinitely narrow and the energy spectrum is a line spectrum as shown in fig.

If  $P \rightarrow \infty$ , then the equation (11) has solution ie

$$\sin \alpha a = 0$$

$$\alpha a = \pm n \Pi$$

$$\alpha = \pm n \Pi / a$$

$$\alpha^2 = n^2 \Pi^2 / a^2$$

But  $\alpha^2 = 2 m E / \hbar^2$

Therefore  $2 m E / \hbar^2 = n^2 \Pi^2 / a^2$

$$E = [\hbar^2 \Pi^2 / 2 m a^2] n^2$$

$$E = n^2 \hbar^2 / 8 m a^2 \quad (\text{since } \hbar = h / 2 \Pi)$$

This expression shows that the energy spectrum of the electron contains discrete energy levels separated by forbidden regions.

4) When  $P \rightarrow 0$  then

$$\cos \alpha a = \cos ka$$

$$\alpha = k, \quad \alpha^2 = k^2$$

$$\text{but } \alpha^2 = 2mE/\hbar^2$$

$$\text{therefore } k^2 = (\hbar^2/2m)(1/\lambda^2) = (\hbar^2/2m)(P^2/\hbar^2)$$

$$E = P^2/2m$$

$$E = 1/2mv^2 \text{ -----(14)}$$

The equation (11) shows all the electrons are completely free to move in the crystal without any constraints. Hence, no energy level exists i.e. all the energies are allowed to the electrons and shown in fig(5). This case supports the classical free electrons theory.

$$[(P/\alpha a) \sin \alpha a + \cos \alpha a], P \rightarrow 0$$

### Velocity of the electron in periodic potential.:

According to quantum theory, an electron moving with a velocity can be treated as a wave packet moving with the group velocity  $v_g$

$$v = v_g = d\omega/dk \text{ -----(1)}$$

where  $\omega$  is the angular frequency of deBroglie wave and  $k = 2\pi/\lambda$  is the wave vector.

The energy of an electron can be expressed as

$$E = \hbar \omega \text{ -----(2)}$$

Differentiating the equation (2) with respect to  $k$

$$dE/dk = \hbar d\omega/dk \text{ -----(3)}$$

from (1) & (3)

$$v_g = 1/\hbar (dE/dk) \text{ -----(4)}$$

According to band theory of solids, the variations of  $E$  with  $k$  as shown in fig(1). Using this graph and equation (4), the velocity of electron can be calculated. The variation of velocity with  $k$  is shown in fig(2). From this fig, it is clear that the velocity of electron is zero at the bottom of the energy band. As the value of  $k$  increases, the velocity of electron increases and reaches to maximum at  $K=k$ . Further, the increases of  $k$ , the velocity of electron decreases and reaches to zero at  $K= \Pi / a$  at the top of energy band.

### Origin Of Energy Bands In Solids:

Solids are usually moderately strong, slightly elastic structures. The individual atoms are held together in solids by interatomic forces or bonds. In addition to these attractive forces, repulsive forces also act and hence solids are not easily compressed.

The attractive forces between the atoms are basically electrostatic in origin. The bonding is strongly dependent on the electronic structure of the atoms. The attraction between the atoms brings them closer until the individual electron clouds begin to overlap. A strong repulsive force arises to comply with Pauli's exclusion principle. When the attractive force and the repulsive force between any two atoms occupy a stable position with a minimum potential energy. The spacing between the atoms under this condition is called equilibrium spacing.

In an isolated atom, the electrons are tightly bound and have discrete, sharp energy levels. When two identical atoms are brought closer, the outermost orbits of these atoms overlap and interact. When the wave functions of the electrons on different atoms begin to overlap considerably, the energy levels corresponding to those wave functions split. If more atoms are brought together more levels are formed and for a solid of  $N$  atoms, each of the energy levels of an atom splits into  $N$  levels of energy. The levels are so close together that they form an almost continuous band. The width of this band depends on the degree of overlap of electrons of adjacent atoms and is largest for the outermost atomic electrons. In a solid many atoms are brought together so that the split energy levels form a set of bands of very closely spaced levels with forbidden energy gaps between them.

### Classification Of Materials:

The electrons first occupy the lower energy bands and are of no importance in determining many of the electrical properties of solids. Instead, the electrons in the higher energy bands of solids are important in determining many of the physical properties of solids. Hence the two allowed energy bands called valence and conduction bands are required. The gap between these two allowed bands is called forbidden energy gap or band gap since electrons can't have any energy values in the forbidden energy gap. The valence band is occupied by valence electrons since they are responsible for electrical, thermal and optical properties of solids. Above the valence band we have the conduction band which is vacant at 0K. According to the gap between the bands and band occupation by electrons, all solids can be classified broadly into two groups.

In the first group of solids called metals there is a partially filled band immediately above the uppermost filled band. This is possible when the valence band is partially filled or a completely filled valence band overlaps with the partially filled conduction band.

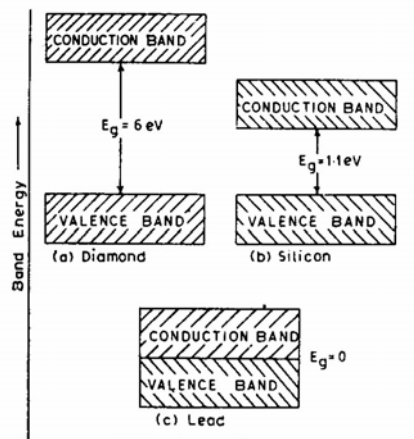

In the second group of solids, there is a gap called band gap between the completely filled valence band and completely empty conduction band. Depending on the magnitude of the gap we can classify insulators and semiconductors.

Insulators have relatively wide forbidden band gaps. For typical insulators the band gap  $E_g > 3 \text{ eV}$ . On the other hand, semiconductors have relatively narrow forbidden bands. For typical semiconductors  $E_g \leq 1 \text{ eV}$ .

**Effective mass of the electron:** When an electron in a periodic potential is accelerated by an electric field (or) magnetic field, then the mass of the electron is called effective mass ( $m^*$ ).

Let an electron of charge 'e' and mass 'm' moving inside a crystal lattice of electric field E.

Acceleration  $a = eE / m$  is not a constant in the periodic lattice of the crystal. It can be considered that its variation is caused by the variation of electron's mass when it moves in the crystal lattice.

Therefore Acceleration  $a = eE / m^*$

$$\text{Electrical force on the electron } F = m^* a \text{ -----(1)}$$

Considering the free electron as a wave packet, the group velocity  $v_g$  corresponding to the particle's velocity can be written as

$$v_g = dw / dk = 2 \Pi dv / dk = (2 \Pi / h) dE / dk \text{ -----(2)}$$

where the energy  $E = h v$  and  $\hbar = h / 2 \Pi$ .

$$\text{Acceleration } a = dv_g / dt = (1 / \hbar) d^2E / dk dt = (1 / \hbar) (d^2E / dk^2) dk / dt$$

$$\text{Since } \hbar k = p \text{ and } dp / dt = F,$$

$$dk / dt = F / \hbar$$

$$\text{Therefore } a = (1 / \hbar^2) (d^2E / dk^2) F$$

$$\text{Or } F = \left( \hbar^2 / \left( d^2E / dk^2 \right) \right) a \text{ -----(3)}$$

Comparing eqns . (1) and (3) we get

$$m^* = \hbar^2 / \left( d^2E / dk^2 \right) \text{ -----(4)}$$

This eqn indicates that the effective mass is determined by  $d^2E / dk^2$  .

### Questions:

1. Explain classical free- electron theory of metals.
2. Define electrical resistance
3. Give the basic assumptions of the classical free electron theory.
4. Explain the following: Drift velocity, mobility, relaxation time and mean free path.
5. Based on free electron theory derive an expression for electrical conductivity of metals.
6. Explain the failures of classical free theory.
7. Explain the salient features of quantum free electron theory.
8. Explain the Fermi- Dirac distribution for free electrons in a metal. Discuss its variation with temperature.
9. Explain the following i) Effective mass, ii) Bloch theorem.
10. Discuss the band theory of solids based on Kronig –Penney model. Explain the important features of this model.
11. Explain the origin of energy bands in solids.
12. Distinguish between metals, semiconductors and insulators.

## UNIT- V

### 8. SEMICONDUCTOR PHYSICS

#### INTRODUCTION:

Semiconductors are materials whose electronic properties are intermediate between those of conductors and insulators. These electrical properties of a solid depend on its band structure. A semiconductor has two bands of importance (neglecting bound electrons as they play no part in the conduction process) the valence and the conduction bands. They are separated by a forbidden energy gap. At OK the valence band is full and the conduction band is empty, the semiconductor behaves as an insulator. Semiconductor has both positive (hole) and negative (electron) carriers of electricity whose densities can be controlled by doping the pure semiconductor with chemical impurities during crystal growth.

At higher temperatures, electrons are transferred across the gap into the conduction band leaving vacant levels in the valence band. It is this property that makes the semiconductor a material with special properties of electrical conduction.

Generally there are two types of semiconductors. Those in which electrons and holes are produced by thermal activation in pure Ge and Si are called intrinsic semiconductors. In other type the current carriers, holes or free electrons are produced by the addition of small quantities of elements of group III or V of the periodic table, and are known as extrinsic semiconductors. The elements added are called the impurities or dopants.

#### Intrinsic semiconductors:

A pure semiconductor which is not doped is termed as intrinsic semiconductor. In Si crystal, the four valence electrons of each Si atom are shared by the four surrounding Si atoms. An electron which may break away from the bond leaves deficiency of one electron in the bond. The vacancy created in a bond due to the departure of an electron is called a hole. The vacancy may get filled by an electron from the neighboring bond, but the hole then shifts to the neighboring bond which in turn may get filled by electron from another bond to whose place the hole shifts, and so on thus in effect the hole also undergoes displacement inside a crystal. Since the hole is associated with deficiency of one electron, it is equivalent for a positive charge of unit magnitude. Hence in a semiconductor, both the electron and the hole act as charge carriers.

In an intrinsic semiconductor, for every electron freed from the bond, there will be one hole created. It means that, the no of conduction electrons is equal to the no of holes at any given temperature. Therefore there is no predominance of one over the other to be particularly designated as charge carriers.

## Carriers Concentration in intrinsic semiconductors:

A broken covalent bond creates an electron that is raised in energy, so as to occupy the conduction band, leaving a hole in the valence band. Both electrons and holes contribute to overall conduction process.

In an intrinsic semiconductor, electrons and holes are equal in numbers. Thus

$$n = p = n_i$$

Where  $n$  is the number of electrons in the conduction band in a unit volume of the material (concentration),  $p$  is the number of holes in the valence band in a unit volume of the material. And  $n_i$ , the number density of charge carriers in an intrinsic semiconductor. It is called intrinsic density.

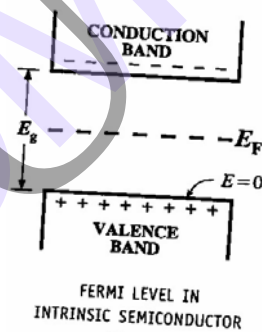

For convenience, the top of the valence band is taken as a zero energy reference level arbitrarily.

The number of electrons in the conduction band is

$$n = N P(E_g)$$



Where  $P(E_g)$  is the probability of an electron having energy  $E_g$ . It is given by Fermi Dirac function eqn., and  $N$  is the total number of electrons in both bands.

Thus,

$$n = \frac{N}{1 + \exp [(E_g - E_F)/KT]}$$

Where  $E_F$  is the Fermi Level

The probability of an electron being in the valence bond is given by putting  $E_g = 0$  in eqn. Hence, the number of electrons in the valence bond is given by

$$n_v = \frac{N}{1 + \exp(-E_F/KT)}$$

The total number of electrons in the semiconductor,  $N$  is the sum of those in the conduction band  $n$  and those in the valence bond  $n_v$ . Thus,

$$N = \frac{N}{1 + \exp [(E_g - E_F) / KT]} + \frac{N}{1 + \exp(-E_F/KT)}$$

For semiconductors at ordinary temperature,  $E_g \gg KT$  as such in equation one may be neglected when compared with  $\exp\left(\frac{E_g - E_F}{RT}\right)$  Then

$$1 = \frac{1}{\exp\left(\frac{E_g - E_F}{RT}\right)} + \frac{1}{1 + \exp\left(-\frac{E_F}{RT}\right)}$$

Rearranging the terms, we get

$$\exp \frac{-E_g + E_F}{RT} = \frac{\exp(-E_F/RT)}{1 + \exp(-E_F/RT)}$$

$$\approx \exp \left( \frac{-E_F}{RT} \right)$$

or  $\exp \left( \frac{2E_F - E_g}{RT} \right) = 1$

This leads to

$$E_F = E_g/2$$

Thus in an intrinsic semiconductor, the Fermi level lies mid way between the conduction and the valence bands. The number of conduction electrons at any temperature T is given by

$$n = \frac{N}{1 + \exp(E_g/2KT)} \quad (\because E_F = E_g/2)$$

In eqn may be approximated as

$$n \approx N \exp(-E_g / 2RT)$$

From the above discussion, the following conclusions may be drawn.

- a) The number of conduction electrons and hence the number of holes in an intrinsic semiconductor, decreases exponentially with increasing gap energy  $E_g$  this accounts for lack of charge carries in insulator of large forbidden energy gap.
- b) The number of available charge carries increases exponentially with increasing temperature.

The above treatment is only approximate as we have assumed that all states in a bond have the same energy. Really it is not so. A more rigorous analysis must include additions terms in eqn.

The no of conduction bond, in fact is given by

$$n = \int S(E) P(E) dE$$

Where  $S(E)$  is the density of available states in the energy range between  $E$  and  $E + dE$ , and  $P(E)$  is the probability, that an electron can occupy a state of energy  $E$ .

$$S(E) = \frac{8\sqrt{2} \pi m^{3/2}}{n^3} E^{1/2}$$

Inclusion of  $S(E)$  and integration over the conduction bond leads to

$$n = N_c \exp [(-E_g - E_F)/RT]$$

In a similar way, we arrive at

$$p = N_v \exp [-E_F/RT]$$

If we multiply eq: we get

$$np = n_i^2 = N_c N_v \exp(-E_g/RT)$$

For the intrinsic material

$$n_i = \frac{2 (2\pi RT)^{3/2}}{h^2} (m_e^* m_n^*)^{3/4} \exp(-E_g/2RT)$$

Notice that this expression agrees with the less rigorous one derived earlier since the temperature dependence is largely controlled by the rapidly varying exponential term.

### EXTRINSIC SEMICONDUCTORS:

Intrinsic Semiconductors are rarely used in semiconductor devices as their conductivity is not sufficiently high. The electrical conductivity is extremely sensitive to certain types of impurity. It is the ability to modify electrical characteristics of the material by adding chosen impurities that make extrinsic semiconductors important and interesting.

Addition of appropriate quantities of chosen impurities is called doping, usually, only minute quantities of dopants (1 part in  $10^3$  to  $10^{10}$ ) are required. Extrinsic or doped semiconductors are classified into main two main types according to the type of charge carriers that predominate. They are the n-type and the p-type.

### N-TYPE SEMICONDUCTORS:

Doping with a pentavalent impurity like phosphorous, arsenic or antimony the semiconductor becomes rich in conduction electrons. It is called n-type the bond structure of an n-type semiconductor is shown in Fig below.

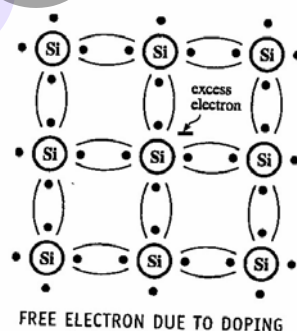

Even at room temperature, nearly all impurity atoms lose an electron into the conduction band by thermal ionization. The additional electrons contribute to the conductivity in the same way as those excited thermally from the valence band. The essential difference being

the two mechanisms is that ionized impurities remain fixed and no holes are produced. Since penta valent impurities denote extra carries elections, they are called donors.

### P-TYPE SEMICONDUCTORS:-

p-type semiconductors have holes as majority charge carries. They are produced by doping an intrinsic semiconductor with trivalent impurities.(e.g. boron, aluminium, gallium, or indium). These dopants have three valence electrons in their outer shell. Each impurity is short of one electron bar covalent bonding. The vacancy thus created is bound to the atom at OK. It is not a hole. But at some higher temperature an electron from a neighbouring atom can fill the vacancy leaving a hole in the valence bond for conduction. It behaves as a positively charge particle of effective mass  $m_h^*$ . The bond structure of a p-type semiconductor is shown in Fig below.

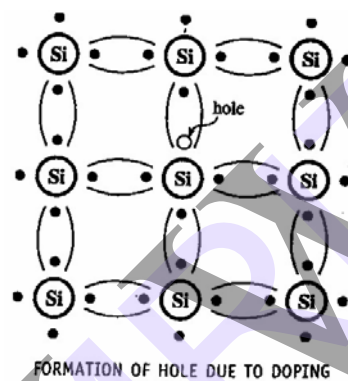

Dopants of the trivalent type are called acceptors, since they accept electrons to create holes above the top of the valence band. The acceptor energy level is small compared with thermal energy of an electron at room temperature. As such nearly all acceptor levels are occupied and each acceptor atom creates a hole in the valence band. In extrinsic semiconductors, there are two types of charge carries. In n-type, electrons are more than holes. Hence electrons are majority carriers and holes are minority carries. Holes are majority carries in p-type semiconductors; electrons are minority carries.

### CARRIER CONCENTRATION IN EXTRINSIC SEMICONDUCTORS:

Equation gives the relation been electron and hole concentrations in a semiconductor. Existence of charge neutrality in a crystal also relates  $n$  and  $p$ . The charge neutrality may be stated as

$$N_D + p = N_A + n$$

Since donors atoms are all ionized,  $N_D$  positive charge per cubic meter are contributed by  $N_D$  donor ions. Hence the total positive charge density =  $N_D + p$ . Similarly if  $N_A$  is the concentration of the acceptor ions, they contribute  $N_A$  negative charge per cubic meter. The total negative charges density =  $N_A + n$ . Since the

semiconductor is electrically neutral the magnitude of the positive charge density must be equal to the magnitude of the total negative charge density.

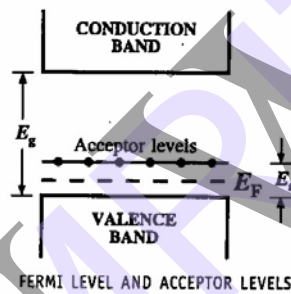
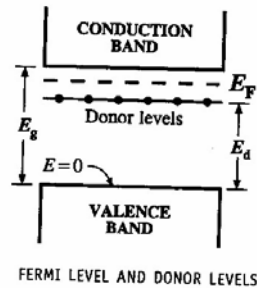

n-type material :  $N_A = 0$  Since  $n \gg p$ , eqn reduces to  $n \approx N_D$  i.e., in an n-type material the where subscript n indicates n-type material. The concentration  $p_n$  of holes in the n-type semiconductor is obtained from eqn i.e.,

$$n_n p_n = n_i^2$$

Thus 
$$p_n \approx \frac{n_i^2}{N_D}$$

Similarly, for a p-type semiconductor  $p_p \approx N_A$  and  $n_p \approx \frac{n_i^2}{N_A}$

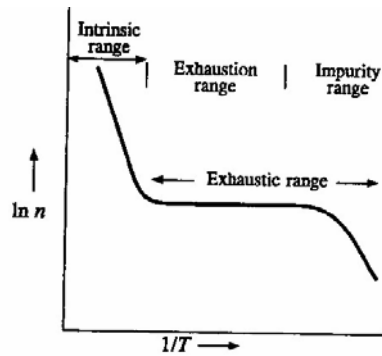

DEPENDENCE OF ELECTRON CONCENTRATION ON TEMPERATURE

### Expression for electrical conductivity:

There are two types of carries in a Semiconductor electrons and holes. Both these carries contribute to conduction. The general expression for conductivity can be written down as

$$\sigma = e(n\mu_e + p\mu_h)$$

Where  $\mu_e$  and  $\mu_h$  are motilities of electrons and holes respectively.

A. Intrinsic Semiconductor; For an intrinsic Semiconductor

$$n = p = n_i$$

eqn becomes

$$\sigma_i = en_i(\mu_n + \mu_p)$$

If the scattering is predominantly due to lattice vibrations.

$$\mu_e = AT^{3/2}$$

$$\mu_h = BT^{3/2}$$

We may put  $\mu_e + \mu_h = (A + B)T^{3/2} = CT^{3/2}$

$$\sigma_i = n_i CT^{3/2}$$

Substituting for  $n_i$  from eq we get

$$\sigma_i = 2 \left( \frac{2\mu RT}{h^2} \right)^{3/2} CT^{3/2} (m_e^* m_h^*)^{3/4} \exp\left( \frac{-E_g}{2RT} \right)$$

$$\log \sigma_i = \log x - \frac{E_g}{2RT}$$

A graph of  $\log \sigma_i$  Vs  $1/T$  gives a straight line shown in fig below:

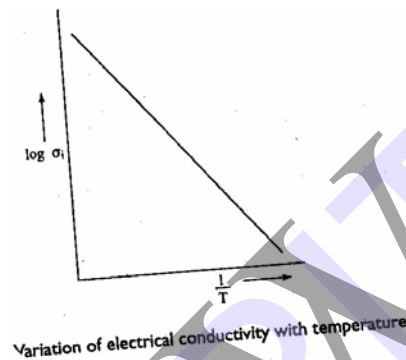

### LIFE TIME OF MINORITY CARRIER:

In Semiconductor devices electron and hole concentrations are very often disturbed from their equilibrium values. This may happen due to thermal agitation or incidence of optical radiation. Even in a pure Semiconductor there will be a dynamic equilibrium. In a pure Semiconductor the number of holes is equal to the number of free electrons. Thermal agitation continuously produces of new EHP per unit volume per second while other EHP disappear due to recombination. On the average a hole exists for a time period of  $T_p$  while an electron exists for a time period  $T_n$  before recombination take place. This time is called the mean life time. If we are dealing with holes in an n-type Semiconductor,  $T_p$  is called the minority carrier life time. These parameters are important in Semiconductor devices as they indicate the time required for electron and hole concentration to return to their equilibrium values after they are disturbed.

Let the equilibrium concentration of electrons and holes in an n-type Semiconductor be  $n_0$  and  $p_0$  respectively. If the specimen is illuminated at  $t = t_i$ , additional EHPs are generated throughout the specimen. The existing equilibrium is disturbed and the new equilibrium concentrations are  $p$  and  $n$ . The excess concentration of holes =  $p - p_0$  - Excess concentration of electrons =  $n - n_0$  Since the radiation creates EHPs.

— — — —



$$p - p_0 = n - n_0$$

Due to incident radiation equal no of holes and electrons are created. However, the percentage increase of minority carriers is much more than the percentage of majority carriers. In fact, the majority charge carrier change is negligibly small. Hence it is the minority charge carrier density that is important. Hence, we shall discuss the behaviour of minority carriers.

As indicated in radiation is removed at  $t = 0$ . Let us investigate how the minority carrier density returns to its original equilibrium value.

The hole concentration decreases as a result of recombination. Decrease in hole concentration per second due to recombination =  $p/T_p$ . But the increase in hole concentration per second due to thermal generation =  $g$ . Since charge can neither be created nor destroyed

$$\frac{dp}{dt} = g - \frac{p}{T_p}$$

When the radiation is withdrawn, the hole concentration  $p$  reaches equilibrium value  $p_0$ . Hence  $g = p_0/T_p$ . Then eqn may be rewritten as

$$\frac{dp}{dt} = \frac{p_0 - p}{T_p}$$

We define excess carrier concentration. Since  $p$  is a function of time.

$$p' = p - p_0 = p'(t)$$

$$\text{from we may write } \frac{dp}{dt} = \frac{-p'}{T_p}$$

The solution to the above differential equation is given by

$$p'(t) = p(0) e^{-t/T_p}$$

The excess concentration decreases exponentially to zero with a time constant  $T_p$ .

### **DRIFT CURRENT:**

In an electric field  $E$ , the drift velocity  $V_d$  of carriers superposes on the thermal velocity  $V_{th}$ . But the flow of charge carriers results in an electric current, known as the drift current. Let a field  $E$  be applied, in the positive direction creating drift currents  $J_{nd}$  and  $J_{pd}$  of electrons and holes respectively.

Without  $E$ , the carriers move randomly with rms velocity  $V_{th}$ . Their mean velocity is zero. The current density will be zero. But the field  $E$  applied, the electrons have the velocity  $V_{de}$  and the holes  $V_{dh}$ .

Consider free electrons in a Semiconductor moving with uniform velocity  $V_{de}$  in the negative  $x$  direction due to an electric field  $E$ . Consider a smaller rectangular block of length  $V_{de}$  inside the Semiconductor. Let the area of the side faces each be unity. The total charge  $Q$  in the elements  $AB$  is

$$Q = \text{Volume of the element} \times \text{density of partially change on each particle} \\ = (V_{de} \times 1 \times 1) \times n \times -q$$

$$\text{Thus } Q = -qnV_{de}$$

Where  $n$  is the number density of electrons. The entire charge of the block will cross the face  $B$ , in unit time. Thus the drift current density  $J_{nd}$  due to free electrons at the face  $B$  will be.

$$J_{nd} = -q nV_{de}$$

$$\text{Similarly for holes } J_{pd} = q nV_{dh}$$

**but**  $V_{de} = -\mu_n E$   
 and  $V_{dh} = \mu_p E$   
 hence  $J_{nd} = n q \mu_n E$   
 and  $J_{pd} = p q \mu_p E$

The total drift current due to both electrons and holes  $J_d$  is

$$J_d = J_{nd} + J_{pd} = (nq\mu_n + pq\mu_p)E$$

Even though electrons and holes move in opposite direction the effective direction of current flow, is the same for both and hence they get added up. Ohm's Law can be written in terms of electrical conductivity, as

$$J_d = \sigma E$$

Equating the RHS of eq we have

$$\sigma = nq\mu_n + pq\mu_p = \sigma_n + \sigma_p$$

For an intrinsic Semiconductor  $n = p = n_i$

$$\sigma_i = n_i q(\mu_n + \mu_p)$$

### DIFFUSION CURRENTS:

1. Diffusion Current: Electric current is Setup by the directed movement of charge carriers. The movements of charge carriers could be due to either drift or diffusion. Non-uniform concentration of carriers gives rise to diffusion. The first law of diffusion by Fick States that the flux  $F$ , i.e., the particle current is proportional and is directed to opposite to the concentration gradient of particles. It can be written mathematically, in terms of concentration  $N$ , as

$$F = -D \nabla N$$

Where  $D$  stands for diffusion constant.

In one dimension it is written as

$$F = -D \frac{\partial N}{\partial x}$$

In terms of  $J_e$  and  $J_p$  the flux densities of electrons holes and their densities  $n$  and  $p$  respectively.

$$\text{We get } J_e = -D_n \frac{\partial n}{\partial x}$$

$$\text{and } J_p = -D_p \frac{\partial p}{\partial x}$$

Where  $D_n$  and  $D_p$  are the electron and hole diffusion constant constants respectively. Then the diffusion current densities become

$$J_{n \text{ diff}} = q D_n \frac{\partial n}{\partial x}$$

$$J_{p \text{ diff}} = -q D_p \frac{\partial p}{\partial x}$$

### THE EINSTEIN RELATIONS:

When both the drift and the diffusion currents are present total electron and hole current densities can be summed up as

$$J_n = J_{nd} + J_{n \text{ diff}}$$

$$J_n = nq\mu_n E + qD_n \frac{\partial n}{\partial x}$$

$$J_p = pq\mu_p E - qD_p \frac{\partial p}{\partial x}$$

Now, let us consider a non uniformly doped n-type slab of the Semiconductor fig shown below (9) under thermal equilibrium. Let the slab be intrinsic at  $x = 0$  while the donor concentration, increases gradually upto  $x = 1$ , beyond which it becomes a constant. Assume that the Semiconductor is non-degenerate and that all the donors are ionized. Due to the concentration gradient, electrons tend to diffuse to the left to  $x = 1$ . This diffusion leaves behind a positive charge of ionized donors beyond  $x = 1$  and accumulates electron near  $x = 0$

plane. This charge imbalance. Sets up an electric field in which the electrons experience force towards  $x = 1$ .

Fig shows illustrates the equilibrium potential  $\phi(x)$  fig shown refers to the band diagram of the Semiconductor.

Both  $E_c$  and  $E_f$  coincide till  $x = 0$  when  $n_0 = n_i$  that  $E_f$  continues to be the same throughout the slab. But since the band structure is not changed due to doping, the band edges bend with equal separation all along. However, the level  $E_i$  continues to lie midway between  $E_c$  and  $E_v$ .

In thermal equilibrium, the electrons tend to diffuse down the concentration tending to setup a current from the right to left. The presence of electric field tends to set up drift current of electrons in the opposite direction. Both the currents add up to zero. Thus we obtain

$$J_n = qD_n \frac{\partial n}{\partial x} + nq\mu_n E = 0$$

$$\text{i.e., } D_n \frac{\partial n}{\partial x} + n\mu_n E = 0$$

For a non degenerate Semiconductor.

$$n(x) = n_i \exp \left[ \frac{E_f - E_i(x)}{RT} \right]$$

Thus relation is valid at all points in the Semiconductor further. The electronic concentration is not influenced by the small imbalance of charge. Energy is defined in terms of  $\phi(x)$  the potential.

$$E(x) = -q\phi(x)$$

$$\text{Then } E_f - E_i(x) = E_i(0) - E_i(x) = -q[\phi(0) - \phi(x)]$$

$$\text{Assuming } \phi(0) = 0 \text{ we get } n(x) = n_i \exp \left[ \frac{q\phi(x)}{RT} \right]$$

$$\frac{dn}{n} = \frac{q}{RT} d\phi$$

Substituting  $\frac{d\phi}{dx}$  from eqn along with  $E = -\frac{d\phi}{dx}$  we get

$$D_n \frac{nq}{RT} \frac{d\phi}{dx} = \mu_n n \frac{d\phi}{dx}$$

Simplifying we obtain,  $D_n = \frac{RT}{q} \mu_n$

Simplifying for holes  $D_p = \frac{RT}{q} \mu_p$

These are known as Einstein relations and the factor  $(RT/q)$  as thermal voltage. The above relations hold good only for non degenerate Semiconductors. For the degenerate case the Einstein's relations are complex.

It is clear from the Einstein's relation that  $D_p, \mu_p$  and  $D_n, \mu_n$  are related and they are functions of temperature also. The relation of diffusion constant  $D$  and the mobility  $\mu$  confirms the fact, that both the diffusion and drift processes arise due to thermal motion and scattering of free electrons, even though they appear to be different.

### EQUATION OF CONTINUITY:

If the equilibrium concentrations of carriers in a Semiconductor are disturbed, the concentrations of electrons and holes vary with time. However the carrier concentration in a Semiconductor is a function of both time and position.

The fundamental law governing the flow of charge is called the continuity equation. It is arrived at by assuming law to conservation of charge provided drift diffusion and recombination processes are taken into account.

Consider a small length  $\Delta x$  of a Semiconductor sample with area  $A$  in the  $Z$  plane fig shown above. The hole current density leaving the volume  $(\Delta x \Delta)$  under consideration is  $J_p(x + \Delta x)$  and the current density entering the volume is  $J_p(x)$ .  $J_p(x + \Delta x)$  may be smaller or

larger than  $J_p(x)$  depending upon the generation and recombination of carriers in the element. The resulting change in hole concentration per unit time.

$\frac{\partial p}{\partial t}$  = hole flux entering per unit time – hole flux leaving per unit

$$\frac{\partial p}{\partial t} = J_p(x) - \frac{J_p(x+\Delta x)}{q \Delta x} - \frac{\delta p}{T_p}$$

Where  $T_p$  is the recombination life time. According to eqn, the rate of hole build up is equal to the rate of increase of hole concentration minus the recombination rate. As  $\Delta x$  approaches zero, we may write

$$\frac{\partial p}{\partial t}(x,t) = \frac{\partial \delta p}{\partial t} = \frac{-1}{q} \frac{\partial J_p}{\partial x} - \frac{\delta p}{T_p}$$

The above is called the continuity equation for holes for electrons

$$\frac{\partial \delta n}{\partial t} = \frac{1}{q} \frac{\partial J_n}{\partial x} - \frac{\delta n}{T_n}$$

If there is no drift we may write

$$J_n(\text{diff}) = qD_n \frac{\partial \delta n}{\partial x}$$

Substituting the above eqn we get the following diffusion eqn for electrons.

$$\frac{\partial \delta n}{\partial t} = D_n \frac{\partial^2 \delta n}{\partial x^2} - \frac{\delta n}{T_n}$$

For holes we may write

$$\frac{\partial \delta p}{\partial t} = D_p \frac{\partial^2 \delta p}{\partial x^2} - \frac{\delta p}{T_p}$$

## HALL EFFECT:

When a material carrying current is subjected to a magnetic field in a direction perpendicular to the direction of current, an electric field is developed across the material in a direction perpendicular to both the direction of the magnetic field and the current direction. This phenomenon is called Hall Effect.

Hall Effect finds important application in studying the electron properties of semiconductor, such as determination of carrier concentration and carrier mobility. It also used to determine whether a semiconductor is n-type, or p-type.

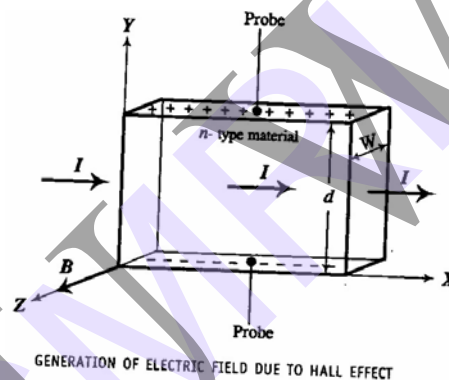

## THEORY:

Consider a rectangular slab of an n-type Semiconductor carrying current in the positive x-direction. The magnetic field  $B$  is acting in the positive direction as indicated in fig above. Under the influence of the magnetic field, electrons experience a force  $F_L$  given by

$$F_L = - Bev \text{ ----- (1)}$$

Where

$e$  = magnitude of the charge of the electron

$v$  = drift velocity

Applying the Fleming's Left Hand Rule, it indicates a force  $F_H$  acting on the electrons in the negative y-direction and electron are deflected down wards. As a consequence the lower face of the specimen gets negatively charged (due to increases of electrons) and the upper face

positively charged (due to loss of electrons). Hence a potential  $V_H$ , called the Hall voltage appears between the top and bottom faces of the specimen, which establishes an electric field  $E_H$ , called the Hall field across the conductor in negative y-direction. The field  $E_H$  exerts an upward force  $F_H$  on the electrons. It is given by

$$F_H = -eE_H \quad \text{-----(2)}$$

$F_H$  acts on electrons in the upward direction. The two opposing forces  $F_L$  and  $F_H$  establish an equilibrium under which

$$|F_L = F_H$$

using eqns 1 and 2

$$-Bev = -eE_H$$

$$E_H = Bv \quad \text{-----(3)}$$

If 'd' is the thickness of the Specimen

$$E_H = \frac{V_H}{d}$$

$$V_H = E_H d = Bvd \quad \text{from eqn (3)----- 4}$$

If  $\omega$  is the width of the specimen in z- direction.

The current density

$$J = \frac{I}{\omega d}$$

$$\text{But } J = nev = \rho v \quad \text{----- 5}$$

Where  $n$  = electron concentration

And  $\rho$  = charge density

$$\therefore \rho v = \frac{I}{\omega d}$$



$$I = \rho \omega d$$

or  $\rho = \frac{I}{\omega d}$  ----- 6

Substituting for  $\rho$ , from eqns 6 and 4

$$V_H = \frac{BI}{\rho \omega}$$

$$\rho = \frac{BI}{V_H \omega}$$

Thus, by measuring  $V_H$ ,  $I$ , and  $\omega$  and by knowing  $B$ , the charge density  $\rho$  can be determined.

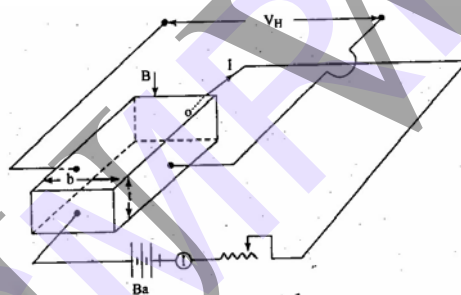

Fig. Experimental set up for the measurement of Hall voltage.

### Hall Coefficient:

The Hall field  $E_H$ , for a given material depends on the current density  $J$ , and the applied field  $B$

i.e.,  $E_H \propto JB$

$$E_H = R_H JB$$

Where  $R_H$  is called the Hall Coefficient

Since  $V_H = \frac{BI}{\rho \omega}$

$$E_H = \frac{V_H}{J\omega d}$$

$$J = \frac{I}{\omega d}$$

$$\frac{BI}{J\omega d} = R_H \frac{I}{\omega d} B$$

This leads to  $R_H = \frac{I}{\rho}$

### Mobility of charge carriers:

The mobility  $\mu$  is given by  $\mu = \frac{v}{E}$

But  $J = \sigma E = nev = \rho v$

$$\therefore \sigma E = \rho v$$

$$\text{or } E = \frac{\rho v}{\sigma}$$

$$\Rightarrow \mu = \frac{\rho v}{\rho} = \sigma R_H \quad (\because 1/\rho = R_H)$$

$\sigma$  is the conductivity of the semi conductor.

### (C) Applications

**(a) Determination of the type of Semiconductor:** The Hall Coefficient  $R_H$  is negative for an n-type Semiconductor and positive for a p-type material. Thus, the sign of the Hall coefficient can be utilized to determine whether a given Semiconductor is n or p type.

**(b) Determination of Carrier Concentration:** Equation relates the Hall Coefficient  $R_H$  and charge density is

$$R_H = \frac{1}{p} = -\frac{1}{ne} \quad (\text{for n-type})$$

$$= \frac{1}{pe} \quad (\text{for p-type})$$

$$\text{Thus } n = \frac{1}{eR_H}$$

$$\text{and } p = \frac{1}{eR_H}$$

**(c) Determination of mobility:** According to equation the mobility of charge carriers is given by

$$\mu = \sigma |R_H|$$

Determination of  $\sigma$  and  $R_H$  leads to a value of mobility of charge carriers.

**(d) Measurement of Magnetic Induction (B):-** The Hall Voltage is proportional to the flux density B. As such measurement of  $V_H$  can be used to estimate B.

## 9. PHYSICS OF SEMICONDUCTOR DEVICES

To describe the basic structure and general properties of semiconductor devices. We will not be showing such devices in working circuits in this set of pages; other pages already under development will serve that purpose. However, I have received a number of inquiries on the order of "What is a MOSFET?" and "What's inside a transistor?" This set of pages is intended to answer such questions. In some cases we'll be dealing with some rather technical terms, and we will sometimes have to deal with some essential concepts involved in physics. More general explanations and definitions will also be given, so if you don't need the technical definitions, don't worry about them. The terms are present in case you actually need them. These pages will begin with basic semiconductor structure and what happens when impurities are added to a pure silicon crystal through a process known as "doping." We'll look at what happens when two or three different regions are created within a single silicon crystal. Then we'll start to look at variations: field-effect devices, devices with four and even five different regions, and finally the kinds of effects we can get when we change the amount of impurities within the crystal.

**Semiconductor diodes are normally one of the following types:**

1. Grown junction diode
2. Alloy type or fused junction diode
3. Diffused junction diode
4. Epitaxial grown or planar diffused diode
5. Point contact diode

### Semiconductor diode fabrication types

#### Fabrication techniques of a P-N junction diode

1. **Grown Junction Diode:** Diodes of this type are formed during the *crystal pulling* process. P and N-type impurities can be alternately added to the molten semiconductor material in the crucible, which results in a P-N junction, as shown when crystal is pulled. After slicing, the larger area device can then be cut into a large number (say in thousands) of smaller-area semiconductor diodes. Though such diodes, because of larger area, are capable of handling large currents but larger area also introduces more capacitive effects, which are undesirable. Such diodes are used for low frequencies.
2. **Alloy Type or Fused Junction Diode:** Such a diode is formed by first placing a P- type impurity (a tiny pellet of aluminium or some other P- type impurity) into the surface of an N- type crystal and heating the two until liquefaction occurs where the two materials meet. An alloy will result that on cooling will give a P-N junction at the boundary of the alloy substrate. Similarly, an N-type impurity may be placed into the surface of a P- type crystal and the two are heated until liquefaction occurs. Alloy type diodes have a high current rating and large PIV (peak inverse voltage) rating. The junction capacitance is also large, due to the large junction area.
3. **Diffused Junction Diode:** Diffusion is a process by which a heavy concentration of particles diffuse into a surrounding region of lower concentration. The main difference between the diffusion and alloy process is the fact that liquefaction is not reached in the diffusion process. In the diffusion process heat is applied only to increase the activity of elements involved. For formation of such diodes, either solid or gaseous diffusion process can be employed. The process of solid diffusion starts with formation of layer of an acceptor impurity on an N- type substrate and heating the two until the impurity diffuses into the substrate to form the P-type layer, as illustrated in figure. A large P-N junction is divided into parts by cutting process. Metallic contacts are made for connecting anode and cathode leads.

In the process of gaseous diffusion instead of layer formation of an acceptor impurity, an N-type substrate is placed in a gaseous atmosphere of acceptor impurities and then heated. The impurity diffuses into the substrate to form P-type layer on the N-type substrate. Though, the diffusion process requires more time than the alloy process but it is relatively inexpensive, and can be very accurately controlled. The diffusion technique leads itself to the simultaneous fabrication of many hundreds of diodes on one small disc of semiconductor material and is most commonly used in the manufacture of semiconductor diodes. This technique is also used in the production of transistors and ICs (integrated circuits).

**4. Epitaxial Growth or Planar Diffused Diode.** The term “epitaxial” is derived from the Latin terms *epi* meaning ‘upon’ and *taxis* meaning “arrangement”. To construct an epitaxially grown diode, a very thin (single crystal) high impurity layer of semiconductor material (silicon or germanium) is grown on a heavily doped substrate (base) of the same material. This complete structure then forms the N-region on which P-region is diffused.  $\text{SiO}_2$  layer is thermally grown on the top surface, photo-etched and then aluminium contact is made to the P-region. A metallic layer at the bottom of the substrate forms the cathode to which lead is attached. This process is usually employed in the fabrication of IC chips.

**5. Point Contact Diode.** It consists of an N-type germanium or silicon wafer about 12.5 mm square by 0.5 mm thick, one face of which is soldered to a metal base by radio-frequency heating and the other face has a phosphor bronze or tungsten spring pressed against it. A barrier layer is formed round the point contact by a pulsating current forming process. This causes a P-region to be formed round the wire and since pure germanium is N-type, a very small P-N junction in the shape of a hemisphere is formed round the point contact. The forming process cannot be controlled with precision. Because of small area of the junction, point contact diode can be used to rectify only very small currents (of the order of mA). On the other hand, the shunting capacitance of point contact diodes are very valuable in equipment operating at super high frequencies (as high as 25,000 MHz).

## The PN Junction

We've seen that it is possible to turn a crystal of pure silicon into a moderately good electrical conductor by adding an impurity such as arsenic or phosphorus (for an N-type semiconductor) or aluminum or gallium (for a P-type semiconductor). By itself, however, a single type of semiconductor material isn't very useful. Useful applications start to happen only when a single semiconductor crystal contains both P-type and N-type regions. Here we will examine the properties of a single silicon crystal which is half N-type and half P-type.

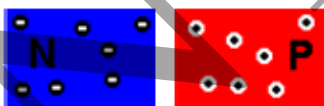

Consider the silicon crystal represented to the right. Half is N-type while the other half is P-type. We've shown the two types separated slightly, as if they were two separate crystals. The free electrons in the N-type crystal are represented by small black circles with a "-" sign inside to indicate their polarity. The holes in the P-type crystal are shown as small white circles with a "+" inside.

In the real world, it isn't possible to join two such crystals together usefully. Therefore, a practical PN junction can only be created by inserting different impurities into different parts of a single crystal. So let's see what happens when we join the N- and P-type crystals together, so that the result is one crystal with a sharp boundary between the two types.



You might think that, left to itself, it would just sit there. However, this is not the case. Instead, an interesting interaction occurs at the junction. The extra electrons in the N region will seek to lose energy by filling the holes in the P region. This leaves an empty zone, or *depletion region* as it is called, around the junction as shown to the right. This action also leaves a small electrical imbalance inside the crystal. The N region is missing some electrons so it has a positive charge. Those electrons have migrated to fill holes in the P region, which therefore has a negative charge. This electrical imbalance amounts to about 0.3 volt in a germanium crystal, and about 0.65 to 0.7 volt in a silicon crystal. This will vary somewhat depending on the concentration of the impurities on either side of the junction. Unfortunately, it is not possible to exploit this electrical imbalance as a power source; it doesn't work that way. However, we can apply an external voltage to the crystal and see what happens in response. Let's take a look at the possibilities.



Suppose we apply a voltage to the outside ends of our PN crystal. We have two choices. In this case, the positive voltage is applied to the N-type material. In response, we see that the positive voltage applied to the N-type material attracts any free electrons towards the end of the crystal and away from the junction, while the negative voltage applied to the P-type end attracts holes away from the junction on this end. The result is that all available current carriers are attracted away from the junction, and the depletion region grows correspondingly larger. There is no current flow through the crystal because all available current carriers are attracted away from the junction, and cannot cross. (We are here considering an ideal crystal -- in real life, the crystal can't be perfect, and some leakage current does flow.) This is known as *reverse bias* applied to the semiconductor crystal.



Here the applied voltage polarities have been reversed. Now, the negative voltage applied to the N-type end pushes electrons towards the junction, while the positive voltage at the P-type end pushes holes towards the junction. This has the effect of shrinking the depletion region. As the applied voltage exceeds the internal electrical imbalance, current carriers of both types can cross the junction into the opposite ends of the crystal. Now, electrons in the P-type end are attracted to the positive applied voltage, while holes in the N-type end are attracted to the negative applied voltage. This is the condition of *forward bias*.

Because of this behavior, an electrical current can flow through the junction in the forward direction, but not in the reverse direction. This is the basic nature of an ordinary semiconductor diode.

It is important to realize that holes exist only within the crystal. A hole reaching the negative terminal of the crystal is filled by an electron from the power source and simply disappears.

At the positive terminal, the power supply attracts an electron out of the crystal, leaving a hole behind to move through the crystal toward the junction again.

In some literature, you might see the N-type connection designated the *cathode* of the diode, while the P-type connection is called the *anode*. These designations come from the days of vacuum tubes, but are still in use. Electrons always move from cathode to anode inside the diode.

One point that needs to be recognized is that there is a limit to the magnitude of the reverse voltage that can be applied to any PN junction. As the applied reverse voltage increases, the depletion region continues to expand. If either end of the depletion region approaches its electrical contact too closely, the applied voltage has become high enough to generate an electrical arc straight through the crystal. This will destroy the diode.

It is also possible to allow too much current to flow through the diode in the forward direction. The crystal is not a perfect conductor, remember; it does exhibit some resistance. Heavy current flow will generate some heat within that resistance. If the resulting temperature gets too high, the semiconductor crystal will actually melt, again destroying its usefulness.

### Drift-Diffusion Current Equations

The popular drift-diffusion model can be derived directly from Boltzmann's transport equation by the method of moments [104] or from the basic principles of irreversible thermodynamics [105]. In this model the electron current density is expressed as a sum of two components: The drift component which is driven by the electric field and the diffusion component caused by the gradient of the electron concentration

$$\mathbf{J} = q \cdot (n \cdot \mu \cdot \mathbf{E} + D_n \cdot \text{grad } n) \quad (3.13)$$

where  $\mu$  and  $D_n$  are the mobility and the diffusivity of the electron gas, respectively. It is

clear from the above reasoning that for anisotropic materials  $\mu$  and  $D_n$  are all tensors of second rank and have the same form as the representative tensor  $\sigma$  in (3.2). They are related by the Einstein relation

$$D_n = \mu \cdot \frac{k_B \cdot T_n}{q} \quad (3.14)$$

where  $k_B$  is the Boltzmann constant and  $T_n = T_L$  the lattice temperature which is constant as the electron gas at drift diffusion is assumed to be in thermal equilibrium.

The current relation (3.13) is inserted into the continuity (3.11) and (3.12) to give a second order parabolic differential equation which is then solved together with POISSON's equation (3.10). More generally, according to the phenomenological equations of drift-

diffusion the electron and hole current densities  $\mathbf{J}_n$  and  $\mathbf{J}_p$  can be expressed as

$$\mathbf{J}_n = q \cdot \mu_n \cdot n \cdot \left( \text{grad} \left( \frac{E_c}{q} - \psi \right) + \frac{k_B \cdot T_L}{q} \cdot \frac{N_{C,0}}{n} \cdot \text{grad} \left( \frac{n}{N_{C,0}} \right) \right) \quad (3.15)$$

$$\mathbf{J}_p = q \cdot \mu_p \cdot p \cdot \left( \text{grad} \left( \frac{E_v}{q} - \psi \right) - \frac{k_B \cdot T_L}{q} \cdot \frac{N_{V,0}}{p} \cdot \text{grad} \left( \frac{p}{N_{V,0}} \right) \right) \quad (3.16)$$

These current relations account for position-dependent band edge energies,  $E_c$  and  $E_v$ , and position-dependent effective masses, which are included in the effective density of states,

$N_{C,0}$  and  $N_{V,0}$ . The index 0 indicates that  $N_{C,0}$  and  $N_{V,0}$  are evaluated at some (arbitrary)

reference temperature,  $T_0$ , which is constant in real space regardless of what the local values of the lattice and carrier temperatures are.



### Current–voltage characteristic

A semiconductor diode's behavior in a circuit is given by its current–voltage characteristic, or I–V graph (see graph at right). The shape of the curve is determined by the transport of charge carriers through the so-called depletion layer or depletion region that exists at the p–n junction between differing semiconductors. When a p–n junction is first created, conduction band (mobile) electrons from the N-doped region diffuse into the P-doped region where there is a large population of holes (places for electrons in which no electron is present) with which the electrons “recombine”. When a mobile electron recombines with a hole, both hole and electron vanish, leaving behind an immobile positively charged donor (the dopant) on the N-side and negatively charged acceptor (the dopant) on the P-side. The region around the p–n junction becomes depleted of charge carriers and thus behaves as an insulator. However, the width of the depletion region (called the depletion width) cannot grow without limit. For each electron-hole pair that recombines, a positively-charged dopant ion is left behind in the N-doped region, and a negatively charged dopant ion is left behind in the P-doped region. As recombination proceeds and more ions are created, an increasing electric field develops through the depletion zone which acts to slow and then finally stop recombination. At this point, there is a “built-in” potential across the depletion zone. If an external voltage is placed across the diode with the same polarity as the built-in potential, the depletion zone continues to act as an insulator, preventing any significant electric current flow (unless electron/hole pairs are actively being created in the junction by, for instance, light. see photodiode). This is the reverse bias phenomenon. However, if the polarity of the external voltage opposes the built-in potential, recombination can once again proceed, resulting in substantial electric current through the p–n junction (i.e. substantial numbers of electrons and holes recombine at the junction).. For silicon diodes, the built-in potential is approximately 0.6 V. Thus, if an external current is passed through the diode, about 0.6 V will be developed across the diode such that the P-doped region is positive with respect to the N-doped region and the diode is said to be “turned on” as it has a forward bias.

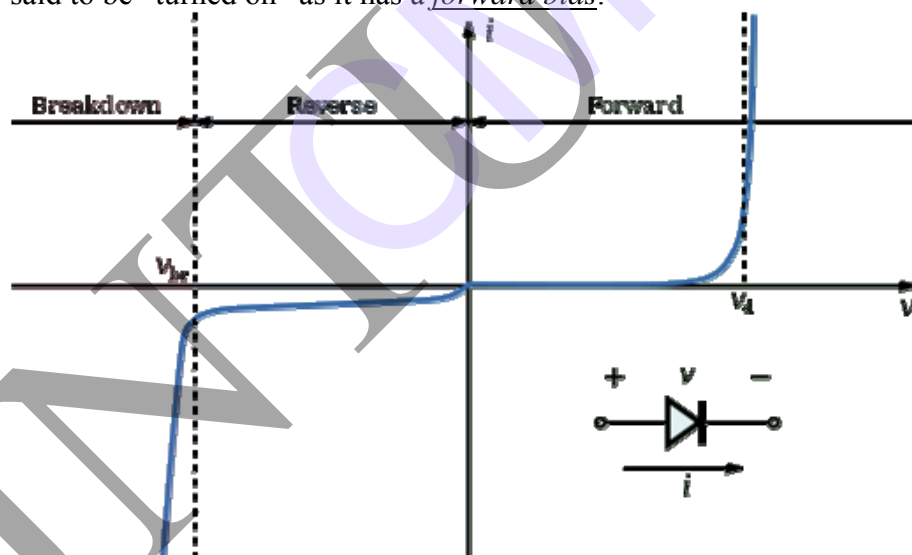

Figure 5: I–V characteristics of a P–N junction diode

A diode's I–V characteristic can be approximated by four regions of operation (see the figure at right).

At very large reverse bias, beyond the peak inverse voltage or PIV, a process called reverse breakdown occurs which causes a large increase in current (i.e. a large number of electrons and holes are created at, and move away from the pn junction) that usually damages the device permanently. The avalanche diode is deliberately designed for use in the avalanche region. In the zener diode, the concept of PIV is not applicable. A zener diode contains a heavily doped p–n junction allowing electrons to tunnel from the valence band of the p-type



material to the conduction band of the n-type material, such that the reverse voltage is “clamped” to a known value (called the *zener voltage*), and avalanche does not occur. Both devices, however, do have a limit to the maximum current and power in the clamped reverse voltage region. Also, following the end of forward conduction in any diode, there is reverse current for a short time. The device does not attain its full blocking capability until the reverse current ceases. The second region, at reverse biases more positive than the PIV, has only a very small reverse saturation current. In the reverse bias region for a normal P-N rectifier diode, the current through the device is very low (in the  $\mu\text{A}$  range). However, this is temperature dependent, and at sufficiently high temperatures, a substantial amount of reverse current can be observed (mA or more).

The third region is forward but small bias, where only a small forward current is conducted. As the potential difference is increased above an arbitrarily defined “cut-in voltage” or “on-voltage” or “diode forward voltage drop ( $V_d$ )”, the diode current becomes appreciable (the level of current considered “appreciable” and the value of cut-in voltage depends on the application), and the diode presents a very low resistance. The current-voltage curve is exponential. In a normal silicon diode at rated currents, the arbitrary “cut-in” voltage is defined as 0.6 to 0.7 volts.

The junction is biased with a voltage  $V_a$  as shown in Figure 4.2.1. We will call the junction forward-biased if a positive voltage is applied to the *p*-doped region and reversed-biased if a negative voltage is applied to the *p*-doped region. The contact to the *p*-type region is also called the anode, while the contact to the *n*-type region is called the cathode, in reference to the *anions* or positive carriers and *cations* or negative carriers in each of these regions.

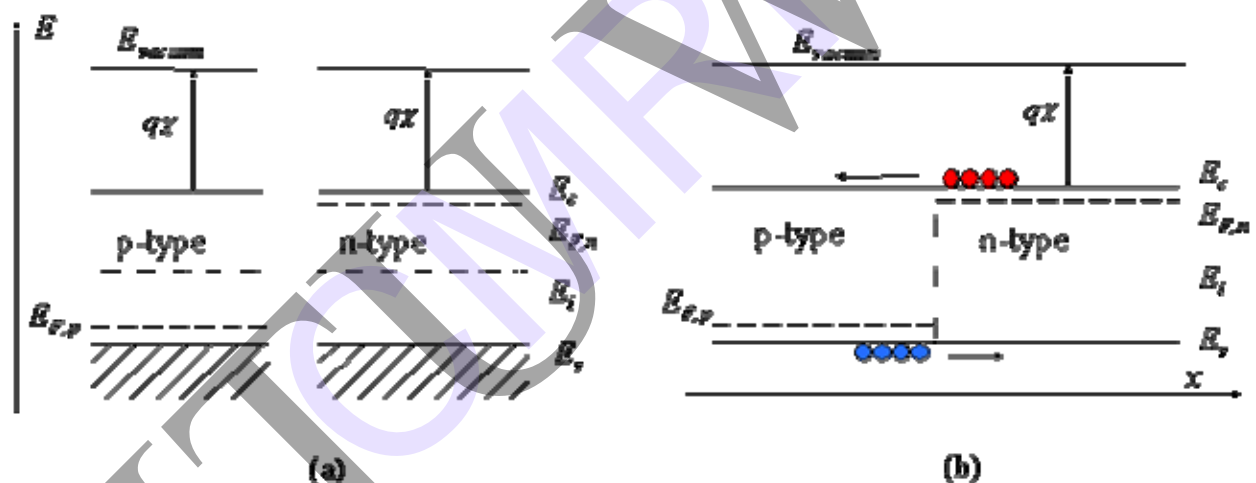

**Figure 4.2.2 :** Energy band diagram of a p-n junction (a) before and (b) after merging the n-type and p-type regions

Note that this does not automatically align the Fermi energies,  $E_{F,n}$  and  $E_{F,p}$ . Also, note that this flatband diagram is not an equilibrium diagram since both electrons and holes can lower their energy by crossing the junction. A motion of electrons and holes is therefore expected before thermal equilibrium is obtained. The diagram shown in Figure 4.2.2 (b) is called a flatband diagram. This name refers to the horizontal band edges. It also implies that there is no field and no net charge in the semiconductor.

#### 4.2.2. Thermal equilibrium

To reach thermal equilibrium, electrons/holes close to the metallurgical junction diffuse across the junction into the *p*-type/*n*-type region where hardly any electrons/holes are present. This process leaves the ionized donors (acceptors) behind, creating a region around the junction, which is depleted of mobile carriers. We call this region the depletion region, extending from  $x = -x_p$  to  $x = x_n$ . The charge due to the ionized donors and acceptors causes an electric field, which in turn causes a drift of carriers in the opposite direction. The diffusion of carriers continues until the drift current balances the diffusion current, thereby reaching thermal equilibrium as indicated by a

constant Fermi energy. This situation is shown in Figure 4.2.3:

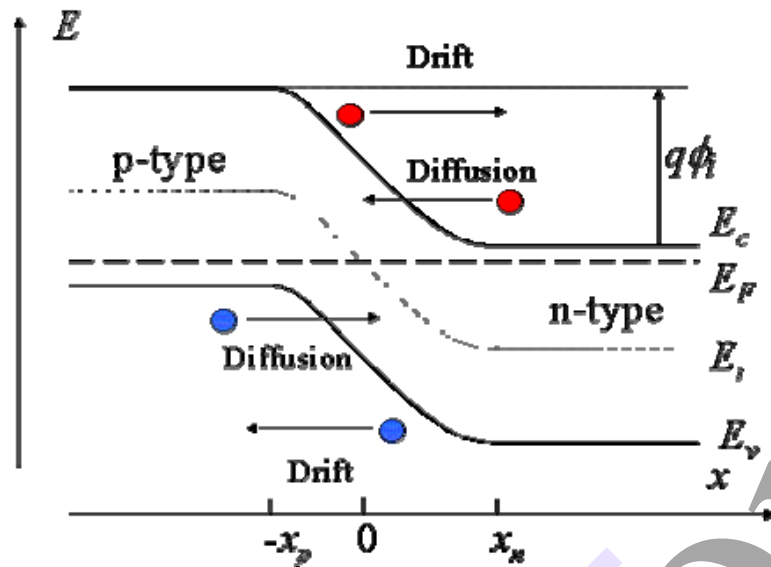

**Figure 4.2.3 :** Energy band diagram of a p-n junction in thermal equilibrium

While in thermal equilibrium no external voltage is applied between the *n*-type and *p*-type material, there is an internal potential,  $\phi_i$ , which is caused by the workfunction difference between the *n*-type and *p*-type semiconductors. This potential equals the *built-in* potential, which will be further discussed in the next section.

#### 4.2.3. The built-in potential

The built-in potential in a semiconductor equals the potential across the depletion region in thermal equilibrium. Since thermal equilibrium implies that the Fermi energy is constant throughout the p-n diode, the built-in potential equals the difference between the Fermi energies,  $E_{Fn}$  and  $E_{Fp}$ , divided by the electronic charge. It also equals the sum of the bulk potentials of each region,  $\phi_n$  and  $\phi_p$ , since the bulk potential quantifies the distance between the Fermi energy and the intrinsic energy. This yields the following expression for the built-in potential.

$$V = V_t \ln \frac{N_d N_a}{n_i^2} \quad (4.2.1)$$

Example 4.1	<p>An abrupt silicon p-n junction consists of a <i>p</i>-type region containing <math>2 \times 10^{16} \text{ cm}^{-3}</math> acceptors and an <i>n</i>-type region containing also <math>10^{16} \text{ cm}^{-3}</math> acceptors in addition to <math>10^{17} \text{ cm}^{-3}</math> donors.</p> <ol style="list-style-type: none"> <li>Calculate the thermal equilibrium density of electrons and holes in the <i>p</i>-type region as well as both densities in the <i>n</i>-type region.</li> <li>Calculate the built-in potential of the p-n junction</li> <li>Calculate the built-in potential of the p-n junction at 400 K.</li> </ol>
Solution	<ol style="list-style-type: none"> <li>The thermal equilibrium densities are: In the <i>p</i>-type region:           <math display="block">p = N_a = 2 \times 10^{16} \text{ cm}^{-3}</math> <math display="block">n = n_i^2/p = 10^{20}/2 \times 10^{16} = 5 \times 10^3 \text{ cm}^{-3}</math>  In the <i>n</i>-type region           <math display="block">n = N_d - N_a = 9 \times 10^{16} \text{ cm}^{-3}</math> </li> </ol>

$$p = n_i^2/n = 10^{20}/(1 \times 10^{16}) = 1.11 \times 10^3 \text{ cm}^{-3}$$

b. The built-in potential is obtained from:

$$\phi = V_T \ln \frac{p_x n_p}{n_i^2} = 0.0259 \ln \frac{2 \times 10^{16} \times 9 \times 10^{16}}{10^{20}} = 0.79 \text{ V}$$

c. Similarly, the built-in potential at 400 K equals:

$$\phi = V_T \ln \frac{p_x n_p}{n_i^2} = 0.0345 \ln \frac{2 \times 10^{16} \times 9 \times 10^{16}}{(4.52 \times 10^{12})^2} = 0.63 \text{ V}$$

where the intrinsic carrier density at 400 K was obtained from example 2.4.b

#### 4.2.4. Forward and reverse bias

We now consider a p-n diode with an applied bias voltage,  $V_a$ . A forward bias corresponds to applying a positive voltage to the anode (the p-type region) relative to the cathode (the n-type region). A reverse bias corresponds to a negative voltage applied to the cathode. Both bias modes are illustrated with Figure 4.2.4. The applied voltage is proportional to the difference between the Fermi energy in the n-type and p-type quasi-neutral regions.

As a negative voltage is applied, the potential across the semiconductor increases and so does the depletion layer width. As a positive voltage is applied, the potential across the semiconductor decreases and with it the depletion layer width. The total potential across the semiconductor equals the built-in potential minus the applied voltage, or:

$$\phi = \phi - V_a \quad (4.2.1)$$

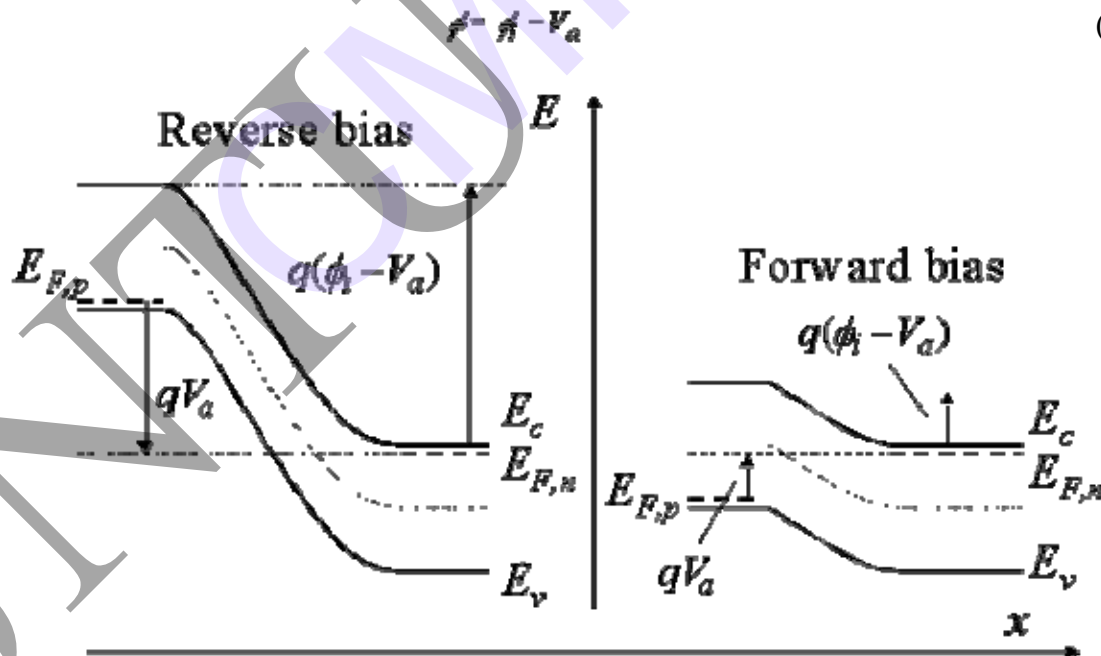

Figure 4.2.4: Energy band diagram of a p-n junction under reverse and forward bias

## Introduction to Light Emitting Diodes

The past few decades have brought a continuing and rapidly evolving sequence of technological revolutions, particularly in the digital arena, which has dramatically changed many aspects of our daily lives. The developing race among manufacturers of light emitting diodes (LEDs) promises to produce, literally, the most visible and far-reaching transition to date. Recent advances in the design and manufacture of these miniature semiconductor devices may result in the obsolescence of the common light bulb, perhaps the most ubiquitous device utilized by modern society.

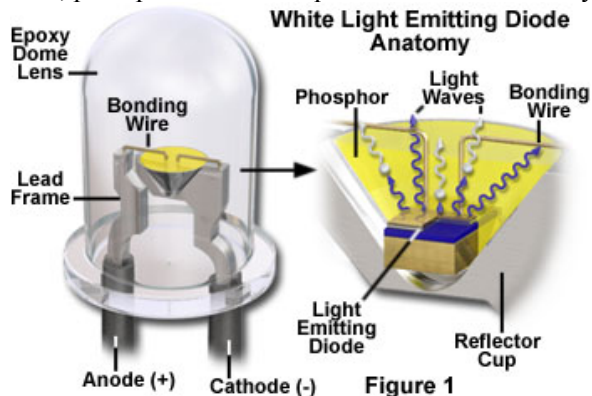
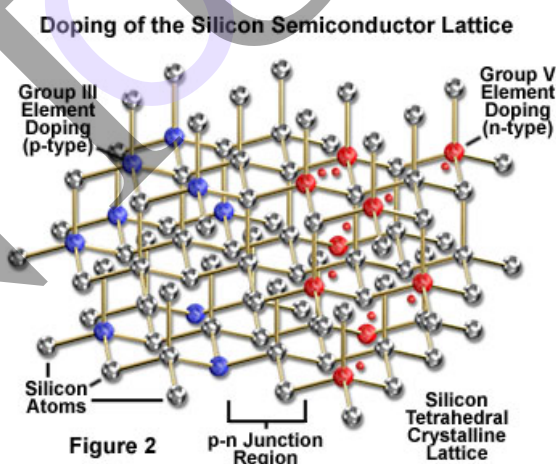

Figure 1

The incandescent lamp is the best known of Thomas Edison's major inventions, and the only one to have persisted in use (and in nearly its original form) to the present day, now more than a century after its introduction. The phonograph, tickertape, and mimeograph machines have been replaced by digital technologies in the last few decades, and recently, full-spectrum light emitting diode devices are becoming widespread, and could force incandescent and fluorescent lamps into extinction. While some applications of LED technology may be as straightforward as replacing one light bulb with another, far more visionary changes may involve dramatic new mechanisms for utilizing light. As a result of the predicted evolution, walls, ceilings, or even entire buildings could become the targets for specialized lighting scenarios, and interior design changes might be accomplished through illumination effects rather than by repainting or refurbishing. At the very least, a widespread change from incandescent to LED illumination would result in enormous energy savings. Although light emitting diodes are in operation all around us in videocassette recorders, clock radios, and microwave ovens, for example, their use has been limited mainly to display functions on electronic appliances. The tiny red and green indicator lights on computers and other devices are so familiar, the fact that the first LEDs were limited to a dim red output is probably not widely recognized. In fact, even the availability of green-emitting diodes represented a significant developmental step in the technology. In the past 15 years or so, LEDs have become much more powerful, and available in a wide spectrum of colors. A breakthrough that enabled fabrication of the first blue LED in the early 1990s, emitting light at the opposite end of the visible light spectrum from red, opened up the possibility to create virtually any color of light. More important, the discovery made it technically feasible to produce white light from the tiny semiconductor devices. An inexpensive, mass-market version of white LED is the most sought-after goal of researchers and manufacturers, and is the device most likely to end a hundred-year reliance on inefficient incandescent lamps. The widespread utilization of diode devices for general lighting is still some years away, but LEDs are beginning to replace incandescent lamps in many applications. There are a number of reasons for replacing conventional incandescent light sources with modern semiconductor alternatives. Light emitting diodes are far more efficient than incandescent bulbs at converting electricity into visible light, they are rugged and compact, and can often last 100,000 hours in use, or about 100 times longer than incandescent bulbs. LEDs are fundamentally monochromatic emitters, and applications requiring high-brightness, single-color lamps are experiencing the greatest number of applications within the current generation of improved devices. The use of LEDs is increasing for automotive taillights, turn signals, and side marker lights. As one of the first automotive applications, the high-mount brake light on cars and trucks is a particularly

appealing location for incorporating LEDs. Long LED lifespans allow manufacturers more freedom to integrate the brake light into the vehicle design without the necessity of providing for frequent (and easy) replacement, as is required when incandescent bulbs are used. Approximately 10 percent of the red traffic lights in the United States have now been replaced with LED-based lamps. The higher initial cost of the LEDs can be recovered in as little as one year, due to their higher efficiency in producing red light, which is accomplished without the need for filtering. The LEDs in a red traffic light consume about 10 to 25 watts, compared with 50 to 150 for a red-filtered incandescent light of similar brightness. The longevity of the LEDs is an obvious advantage in reducing expensive maintenance of the signals. Single-color LEDs are also being utilized as runway lights at airports and as warning lights on radio and television transmission towers. As improvements have been made in manufacturing efficiency and toward the ability to produce light emitting diodes with virtually any output color, the primary focus of researchers and industry has become the white light diode. Two primary mechanisms are being employed to produce white light from devices that are fundamentally monochromatic, and both techniques will most likely continue to be utilized for different applications. One method involves mixing different colors of light from multiple LEDs, or from different materials in a single LED, in proportions that result in light that appears white. The second technique relies on using LED emission (commonly non-visible ultraviolet) to provide energy for excitation of another substance, such as a phosphor, which in turn produces white light. Each method has both advantages and disadvantages that are likely to be in constant flux as further developments occur in LED technology.

**Fundamentals of Semiconductor Diodes** Details of the fundamental processes underlying the function of light emitting diodes, and the materials utilized in their construction, are presented in the ensuing discussion. The basic mechanism by which LEDs produce light can be summarized, however, by a simple conceptual description. The familiar light bulb relies upon temperature to emit visible light (and significantly more invisible radiation in the form of heat) through a process known as incandescence. In contrast, the light emitting diode employs a form of electroluminescence, which results from the electronic excitation of a semiconductor material. The basic LED consists of a junction between two different semiconductor materials (illustrated in Figure 2), in which an applied voltage produces a current flow, accompanied by the emission of light when charge carriers injected across the junction are recombined.



The fundamental element of the LED is a semiconductor chip (similar to an integrated circuit), which is mounted in a reflector cup supported by a lead frame connected to two electrical wires, and then embedded in a solid epoxy lens (see Figure 1). One of the two semiconductor regions that comprise the junction in the chip is dominated by negative charges (n-type region; Figure 2)), and the other is dominated by positive charges (p-type region). When a sufficient voltage is applied to the electrical leads, current flows and electrons move across the junction from the n region into the p region where the negatively charged electrons combine with positive charges. Each combination of charges is associated with an energy level reduction that may release a



quantum of electromagnetic energy in the form of a light photon. The frequency, and perceived color, of emitted photons is characteristic of the semiconductor material, and consequently, different colors are achieved by making changes in the semiconductor composition of the chip. The functional details of the light emitting diode are based on properties common to semiconductor materials, such as silicon, which have variable conduction characteristics. In order for a solid to conduct electricity, its resistance must be low enough for electrons to move more or less freely throughout the bulk of the material. Semiconductors exhibit electrical resistance values intermediate between those of conductors and insulators, and their behavior can be modeled in terms of the band theory for solids. In a crystalline solid, electrons of the constituent atoms occupy a large number of energy levels that may differ very little either in energy or in quantum number. The wide spectrum of energy levels tend to group together into nearly continuous energy bands, the width and spacing of which differ considerably for different materials and conditions. At progressively higher energy levels, proceeding outward from the nucleus, two distinct energy bands can be defined, which are termed the valence band and the conduction band (Figure 3). The valence band consists of electrons at a higher energy level than the inner electrons, and these have some freedom to interact in pairs to form a type of localized bond among atoms of the solid. At still-higher energy levels, electrons of the conduction band behave similarly to electrons in individual atoms or molecules that have been excited above ground state, with a high degree of freedom to move about within the solid. The difference in energy between the valence and conduction bands is defined as the band gap for a particular material. In conductors, the valence and conduction bands partially overlap in energy (see Figure 3), so that a portion of the valence electrons always resides in the conduction band. The band gap is essentially zero for these materials, and with part of the valence electrons moving freely into the conduction band, vacancies or holes occur in the valence band. Electrons move, with very little energy input, into holes in bands of adjacent atoms, and the holes migrate freely in the opposite direction. In contrast to these materials, insulators have fully occupied valence bands and larger band gaps, and the only mechanism by which electrons can move from atom to atom is for a valence electron to be displaced into the conduction band, requiring a large energy expenditure.

Semiconductors have band gaps that are small but finite, and at normal temperatures, thermal agitation is sufficient to move some electrons into the conduction band where they can contribute to electrical conduction. Resistance can be reduced by increasing the temperature, but many semiconductor devices are designed in such a manner that the application of a voltage produces the required changes in electron distribution between the valence and conduction bands to enable current flow. Although the band arrangement is similar for all semiconductors, there are large differences in the band gap (and in the distribution of electrons among the bands) at specific temperature conditions.

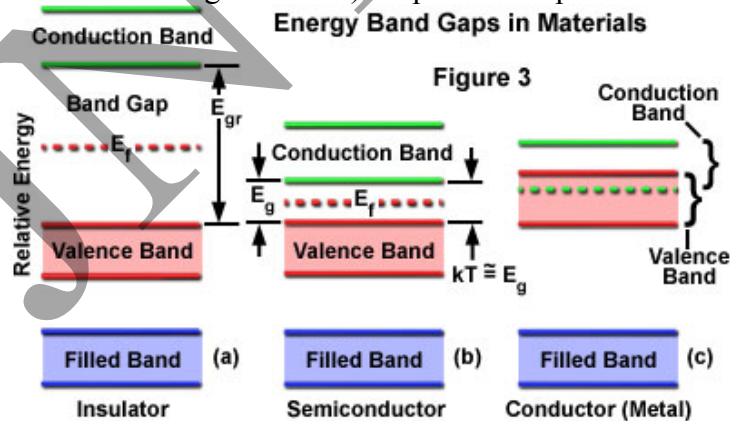

The element silicon is the simplest intrinsic semiconductor, and is often used as a model for describing the behavior of these materials. In its pure form, silicon does not have sufficient charge carriers, or appropriate band gap structure, to be useful in light emitting diode construction, but is widely used to fabricate other semiconductor devices. The conduction

characteristics of silicon (and other semiconductors) can be improved through the introduction of impurities in small quantities to the crystal, which serve to provide either additional electrons or vacancies (holes) in the structure. Through this process, referred to as doping, producers of integrated circuits have developed considerable ability to tailor the properties of semiconductors to suit specific applications. The process of doping to modify the electronic properties of semiconductors is most easily understood by considering the relatively simple silicon crystal structure. Silicon is a Group IV member of the periodic table, having four electrons that may participate in bonding with neighboring atoms in a solid. In pure form, each silicon atom shares electrons with four neighbors, with no deficit or excess of electrons beyond those required in the crystal structure. If a small amount of a Group III element (those having three electrons in their outermost energy level) is added to the silicon structure, an insufficient number of electrons exist to satisfy the bonding requirements. The electron deficiency creates a vacancy, or hole, in the structure, and the resulting positive electrical character classifies the material as p-type. Boron is one of the elements that is commonly utilized to dope pure silicon to achieve p-type characteristics.

Doping in order to produce the opposite type of material, having a negative overall charge character (n-type), is accomplished through the addition of Group V elements, such as phosphorus, which have an "extra" electron in their outermost energy level. The resulting semiconductor structure has an excess of available electrons over the number required for covalent silicon bonding, which bestows the ability to act as an electron donor (characteristic of n-type material). Although silicon and germanium are commonly employed in semiconductor fabrication, neither material is suitable for light emitting diode construction because junctions employing these elements produce a significant amount of heat, but only a small quantity of infrared or visible light emission. Photon-emitting diode p-n junctions are typically based on a mixture of Group III and Group V elements, such as gallium arsenide, gallium arsenide phosphide, and gallium phosphide. Careful control of the relative proportions of these compounds, and others incorporating aluminum and indium, as well as the addition of dopants such as tellurium and magnesium, enables manufacturers and researchers to produce diodes that emit red, orange, yellow, or green light. Recently the use of silicon carbide and gallium nitride has permitted blue-emitting diodes to be introduced, and combining several colors in various combinations provides a mechanism to produce white light. The nature of materials comprising p-type and n-type sides of the device junction, and the resulting energy band structure, determines the energy levels that are available during charge recombination in the junction region, and therefore, the magnitude of the energy quanta released as photons. As a consequence, the color of light emitted by a particular diode depends upon the structure and composition of the p-n junction. The fundamental key to manipulating properties of solid-state electronic devices is the nature of the p-n junction. When dissimilar doped materials are placed in contact with each other, the flow of current in the region of the junction is different than it is in either of the two materials alone. Current will readily flow in one direction across the junction, but not in the other, constituting the basic diode configuration. This behavior can be understood in terms of the movement of electrons and holes in the two material types and across the junction. The extra free electrons in the n-type material tend to move from the negatively charged area to a positively charged area, or toward the p-type material. In the p-type region, which has vacant electron sites (holes), lattice electrons can jump from hole to hole, and will tend to move away from the negatively charged area. The result of this migration is that the holes appear to move in the opposite direction, or away from the positively charged region and toward the negatively charged area (Figure 4). Electrons from the n-type region and holes from the p-type region recombine in the vicinity of the junction to form a depletion zone (or layer), in which no charge carriers remain. In the depletion zone, a static charge is established that inhibits any additional electron transfer, and no appreciable charge can flow across the junction unless assisted by an external bias voltage.

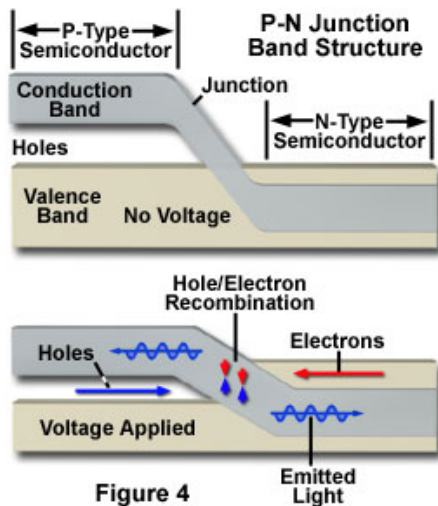

Figure 4

In a diode configuration, electrodes on opposite ends of the device enable a voltage to be applied in a manner that can overcome the effect of the depletion region. Connecting the n-type region of the diode to the negative side of an electrical circuit, and the p-type region to the positive side will cause electrons to move from the n-type material toward the p-type, and holes to move in the opposite direction. With application of a sufficiently high voltage, the electrons in the depletion region are elevated in energy to dissociate with the holes, and to begin moving freely again. Operated with this circuit polarity, referred to as forward biasing of the p-n junction, the depletion zone disappears and charge can move across the diode. Holes are driven to the junction from the p-type material and electrons are driven to the junction from the n-type material. The combination of holes and electrons at the junction allows a continuous current to be maintained across the diode.

If the circuit polarity is reversed with respect to the p-type and n-type regions, electrons and holes will be pulled in opposite directions, with an accompanying widening of the depletion region at the junction. No continuous current flow occurs in a reverse-biased p-n junction, although initially a transient current will flow as the electrons and holes are pulled away from the junction. Current flow will cease as soon as the growing depletion zone creates a potential that is equal to the applied voltage.

#### Light Emitting Diode Construction

Manipulation of the interaction between electrons and holes at the p-n junction is fundamental in the design of all semiconductor devices, and for light emitting diodes, the primary design goal is the efficient generation of light. Injection of carriers across the p-n junction is accompanied by a drop in electron energy levels from the conduction band to lower orbitals. This process takes place in any diode, but only produces visible light photons in those having specific material compositions. In a standard silicon diode, the energy level difference is relatively small, and only low frequency emission occurs, predominately in the infrared region of the spectrum. Infrared diodes are useful in many devices, including remote controls, but the design of visible-light emitting diodes requires fabrication with materials exhibiting a wider gap between the conduction band and orbitals of the valence band. All semiconductor diodes release some form of light, but most of the energy is absorbed into the diode material itself unless the device is specifically designed to release the photons externally. In addition, to be useful as a light source, diodes must concentrate light emission in a specific direction. Both the composition and construction of the semiconductor chip, and the design of the LED housing, contribute to the nature and efficiency of energy emission from the device. The basic structure of a light emitting diode consists of the semiconductor material (commonly referred to as a die), a lead frame on which the die is placed, and the encapsulation epoxy surrounding the assembly (see Figure 1). The LED semiconductor chip is supported in a reflector cup coined into the end of one electrode (the cathode), and, in the typical configuration, the top face of the chip is connected with a gold bonding wire to a second electrode (anode). Several junction structure designs require two bonding wires, one



to each electrode. In addition to the obvious variation in the radiation wavelength of different LEDs, there are variations in shape, size, and radiation pattern. The typical LED semiconductor chip measures approximately 0.25 millimeter-square, and the epoxy body ranges from 2 to about 10 millimeters in diameter. Most commonly, the body of the LED is round, but they may be rectangular, square, or triangular.

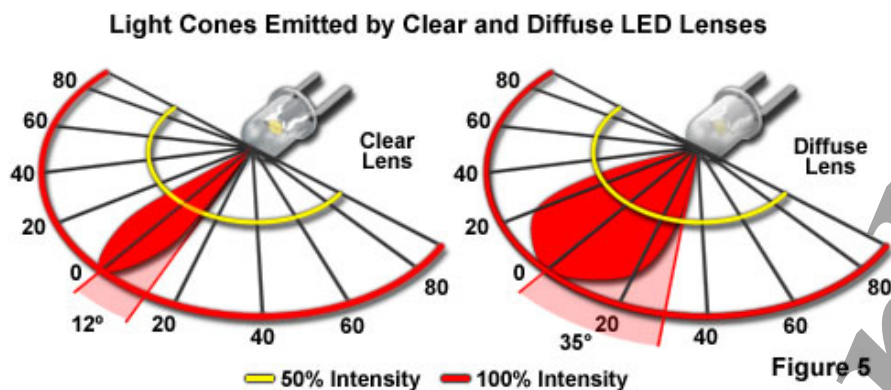

Although the color of light emitted from a semiconductor die is determined by the combination of chip materials, and the manner in which they are assembled, certain optical characteristics of the LED can be controlled by other variables in the chip packaging. The beam angle can be narrow or wide (see Figure 5), and is determined by the shape of the reflector cup, the size of the LED chip, the distance from chip to the top of the epoxy housing or lens, and the geometry of the epoxy lens. The tint of the epoxy lens does not determine the emission color of the LED, but is often used as a convenient indicator of the lamp's color when it is inactive. LEDs intended for applications that require high intensity, and no color in the off-state, have clear lenses with no tint or diffusion. This type produces the greatest light output, and may be designed to have the narrowest beam, or viewing angle. Non-diffused lenses typically exhibit viewing angles of plus or minus 10 to 12 degrees (Figure 5). Their intensity allows them to be utilized for backlighting applications, such as the illumination of display panels on electronic devices. For creation of diffused LED lenses, minute glass particles are embedded in the encapsulating epoxy. The diffusion created by inclusion of the glass spreads light emitted by the diode, producing a viewing angle of approximately 35 degrees on either side of the central axis. This lens style is commonly employed in applications in which the LED is viewed directly, such as for indicator lamps on equipment panels. The choice of material systems and fabrication techniques in LED construction is guided by two primary goals—maximization of light generation in the chip material, and the efficient extraction of the generated light. In the forward-biased p-n junction, holes are injected across the junction from the p region into the n region, and electrons are injected from the n region into the p region. The equilibrium charge carrier distribution in the material is altered by this injection process, which is referred to as minority-carrier injection. Recombination of minority carriers with majority carriers takes place to reestablish thermal equilibrium, and continued current flow maintains the minority-carrier injection. When the recombination rate is equal to the injection rate, a steady-state carrier distribution is established. Minority-carrier recombination can take place in a radiative fashion, with the emission of a photon, but for this to occur the proper conditions must be established for energy and momentum conservation. Meeting these conditions is not an instantaneous process, and a time delay results before radiative recombination of the injected minority carrier can take place. This delay, the minority carrier lifetime, is one of the primary variables that must be considered in LED material design. Although the radiative recombination process is desirable in LED design, it is not the only recombination mechanism that is possible in semiconductors. Semiconductor materials cannot be produced without some impurities, structural dislocations, and other crystalline defects, and these can all trap injected minority carriers. Recombinations of this type may or may not produce light photons. Recombinations that do not produce radiation are slowed by the diffusion of the carriers to

suitable sites, and are characterized by a nonradiative process lifetime, which can be compared to the radiative process lifetime. An obvious goal in LED design, given the factors just described, is to maximize the radiative recombination of charge carriers relative to the nonradiative. The relative efficiency of these two processes determines the fraction of injected charge carriers that combine radiatively compared to the total number injected, which can be stated as the internal quantum efficiency of the material system. The choice of materials for LED fabrication relies upon an understanding of semiconductor band structure and the means by which the energy levels can be chosen or manipulated to produce favorable quantum efficiency values. Interestingly, certain groups of III-V compounds have internal quantum efficiencies of nearly 100 percent, while other compounds utilized in semiconductors may have internal quantum efficiencies as low as 1 percent. The radiative lifetime for a particular semiconductor largely determines whether radiative recombinations occur before nonradiative. Most semiconductors have similar simple valence band structure with an energy peak situated around a particular crystallographic direction, but with much more variation in the structure of the conduction band. Energy valleys exist in the conduction band, and electrons occupying the lowest-energy valleys are positioned to more easily participate in recombination with minority carriers in the valence band. Semiconductors can be classified as direct or indirect depending upon the relative positioning of the conduction band energy valleys and the energy apex of the valence band in energy/momentum space. Direct semiconductors have holes and electrons positioned directly adjacent at the same momentum coordinates, so that electrons and holes can recombine relatively easily while maintaining momentum conservation. In an indirect semiconductor, the match between conduction band energy valleys and holes that would allow momentum conservation is not favorable, most of the transitions are forbidden, and the resulting radiative lifetime is long.

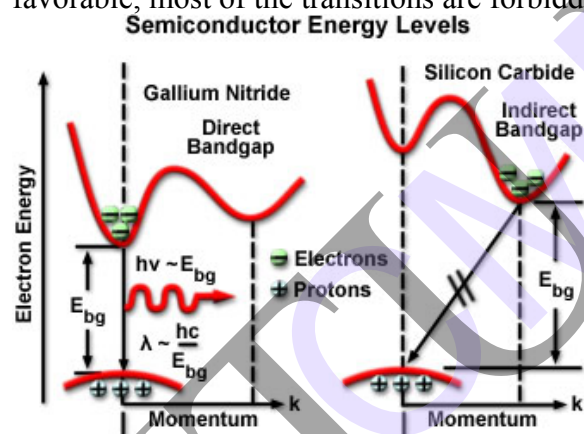
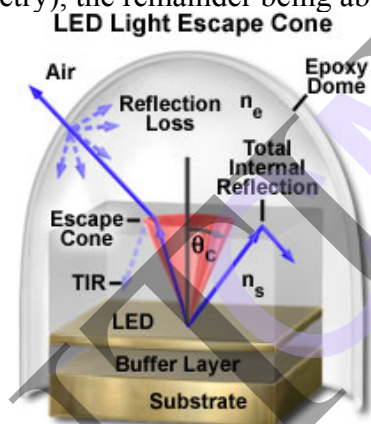

Figure 6

Silicon and germanium are examples of indirect semiconductors, in which radiative recombination of injected carriers is extremely unlikely. The radiative lifetime in such materials occurs in the range of seconds, and nearly all injected carriers combine nonradiatively through defects in the crystal. Direct semiconductors, such as gallium nitride or gallium arsenide, have short radiative lifetimes (approximately 1 to 100 nanoseconds), and materials can be produced with sufficiently low defect density that radiative processes are as likely as nonradiative. For a recombination event to occur in indirect gap materials, an electron must change its momentum before combining with a hole, resulting in a significantly lower recombination probability for the occurrence of a band-to-band transition. The quantum efficiencies exhibited by LEDs constructed of the two types of semiconductor material clearly reflect this fact. Gallium nitride LEDs have quantum efficiencies as high as 12 percent, compared to the 0.02 percent typical of silicon carbide LEDs. Figure 6 presents an energy band diagram for direct band gap GaN and indirect band gap SiC that illustrates the nature of the band-to-band energy transition for the two types of material. The wavelength (and color) of light emitted in a radiative recombination of carriers injected across a p-n junction is determined by the difference in energy between the recombining electron-hole pair of the valence and conduction bands. The approximate energies of the carriers correspond to the upper energy level of the valence band and the

lowest energy of the conduction band, due to the tendency of the electrons and holes to equilibrate at these levels. Consequently, the wavelength ( $\lambda$ ) of an emitted photon is approximated by the following expression:

$\lambda = hc/E_{bg}$  where  $h$  represents Planck's constant,  $c$  is the velocity of light, and  $E_{bg}$  is the band gap energy. In order to change the wavelength of emitted radiation, the band gap of the semiconducting material utilized to fabricate the LED must be changed. Gallium arsenide is a common diode material, and may be used as an example illustrating the manner in which a semiconductor's band structure can be altered to vary the emission wavelength of the device. Gallium arsenide has a band gap of approximately 1.4 electron-volts, and emits in the infrared at a wavelength of 900 nanometers. In order to increase the frequency of emission into the visible red region (about 650 nanometers), the band gap must be increased to approximately 1.9 electron-volts. This can be achieved by mixing gallium arsenide with a compatible material having a larger band gap. Gallium phosphide, having a band gap of 2.3 electron-volts, is the most likely candidate for this mixture. LEDs produced with the compound GaAsP (gallium arsenide phosphide) can be customized to produce band gaps of any value between 1.4 and 2.3 electron-volts, through adjustment of the content of arsenic to phosphorus. As previously discussed, maximization of light generation in the diode semiconductor material is a primary design goal in LED fabrication. Another requirement is the efficient extraction of the light from the chip. Because of total internal reflection, only a fraction of the light that is generated isotropically within the semiconductor chip can escape to the outside. According to Snell's law, light can travel from a medium of higher refractive index into a medium of lower refractive index only if it intersects the interface between the two media at an angle less than the critical angle for the two media. In a typical light-emitting semiconductor having cubic shape, only about 1 to 2 percent of the generated light escapes through the top surface of the LED (depending upon the specific chip and p-n junction geometry), the remainder being absorbed within the semiconductor materials.



**Figure 7** Figure 7 illustrates the escape of light from a layered semiconductor chip of refractive index  $n(s)$  into epoxy of lower index ( $n(e)$ ). The angle subtended by the escape cone is defined by the critical angle,  $\theta(c)$ , for the two materials. Light rays emerging from the LED at angles less than  $\theta(c)$  escape into the epoxy with minimal reflection loss (dashed ray lines), while those rays propagating at angles greater than  $\theta(c)$  undergo total internal reflection at the boundary, and do not escape the chip directly. Because of the curvature of the epoxy dome, most light rays leaving the semiconductor material meet the epoxy/air interface at nearly right angles, and emerge from the housing with little reflection loss.

The proportion of light emitted from an LED chip into the surroundings is dependent upon the number of surfaces through which light can be emitted, and how effectively this occurs at each surface. Nearly all LED structures rely on some form of layered arrangement in which epitaxial growth processes are utilized to deposit several lattice-matched materials on top of one another to tailor the properties of the chip. A wide variety of structures is employed, with each material system requiring different layer architecture in order to optimize performance properties.

Most of the LED structural arrangements rely on a secondary growth step to deposit a single-crystal layer on top of a single-crystal bulk-grown substrate material. Such a multilayering approach enables designers to satisfy seemingly contradictory or inconsistent requirements. A common feature of all of the structural types is that the p-n junction, where the light emission occurs, is almost never located in the bulk-grown substrate crystal. One reason for this is that bulk-grown material generally has a high defect density, which lowers the light generation efficiency. In addition, the most common bulk-grown materials, including gallium arsenide, gallium phosphide, and indium phosphide, do not have the appropriate band gap for the desired emission wavelengths. Another requirement in many LED applications is for a low series resistance that can be met by appropriate substrate choice, even in cases in which the low doping required in the p-n junction region would not provide adequate conduction. The techniques of epitaxial crystal growth involve deposition of one material on another, which is closely matched in atomic lattice constants and thermal expansion coefficient to reduce defects in the layered material. A number of techniques are in use to produce epitaxial layers. These include Liquid Phase Epitaxy (LPE), Vapor Phase Epitaxy (VPE), Metal-Organic Epitaxial Chemical Vapor Deposition (MOCVD), and Molecular Beam Epitaxy (MBE). Each of the growth techniques has advantages in particular materials systems or production environments, and these factors are extensively discussed in the literature. The details of the various epitaxial structures employed in LED fabrication are not presented here, but are discussed in a number of publications. Generally, however, the most common categories of such structures are grown and diffused homojunctions, and single confinement or double confinement heterojunctions. The strategies behind the application of the various layer arrangements are numerous. These include structuring of p and n regions and reflective layers to increase the internal quantum efficiency of the system, graded-composition buffer layers to overcome lattice mismatch between layers, locally varying energy band gap to accomplish carrier confinement, and lateral constraint of carrier injection to control light emission area or to collimate the emission. Even though it does not typically contain the p-n junction region, the LED substrate material becomes an integral part of the function, and is chosen to be appropriate for deposition of the desired epitaxial layers, as well as for its light transmission and other properties. As previously stated, the fraction of generated light that is actually emitted from an LED chip is a function of the number of surfaces that effectively transmit light. Most LED chips are categorized as absorbing substrate (AS) devices, where the substrate material has a narrow band gap and absorbs all emission having energy greater than the band gap. Therefore, light traveling toward the sides or downward is absorbed, and such chips can only emit light through their top surfaces. The transparent substrate (TS) chip is designed to increase light extraction by incorporating a substrate that is transparent to the wavelength of emitted light. In some systems, transparency in the upper epitaxial layers will allow light transmitted toward the side surfaces, within certain angles, to be extracted as well. Hybrid designs, having substrate properties intermediate between AS and TS devices, are also utilized, and significant increases in extraction efficiency can be achieved by employment of a graded change in refractive index from the LED chip to air. There remain numerous other absorption mechanisms in the LED structure that reduce emission and are difficult to overcome, such as the front and back contacts on the chip, and crystal defects. However, chips made on transparent, as opposed to absorbing, substrates can exhibit a nearly-fivefold improvement in extraction efficiency.

Dyes are another suitable type of wavelength converter for white diode applications, and can be incorporated into the epoxy encapsulant or in transparent polymers. The commercially available dyes are generally organic compounds, which are chosen for a specific LED design by consideration of their absorption and emission spectra. The light generated by the diode must match the absorption profile of the converting dye, which in turn emits light at the desired longer wavelength. The quantum efficiencies of dyes can be near 100 percent, as in phosphor conversion, but they have the disadvantage of poorer long-term operational stability than phosphors. This is a serious drawback, as the molecular instability of the dyes causes them to



lose optical activity after a finite number of absorptive transitions, and the resulting change in light emitting diode color will limit its lifetime. White light LEDs based on semiconductor wavelength converters have been demonstrated that are similar in principle to the phosphor conversion types, but which employ a second semiconductor material that emits a different wavelength in response to the emission from the primary source wafer. These devices have been referred to as photon recycling semiconductors (or PRS-LEDs), and incorporate a blue-emitting LED die bonded to another die that responds to the blue light by emitting light of a complementary wavelength. The two wavelengths then combine to produce white. One possible structure for this type of device utilizes a GaInN diode as a current-injected active region coupled to an AlGaInP optically-excited active region. The blue light emitted by the primary source is partially absorbed by the secondary active region, and "recycled" as reemitted photons of lower energy. The structure of a photon recycling semiconductor is illustrated schematically in Figure 11. In order for the combined emission to produce white light, the intensity ratio of the two sources must have a specific value that can be calculated for the particular dichromatic components. The choice of materials and the thickness of the various layers in the structure can be modified to vary the color of the device output.

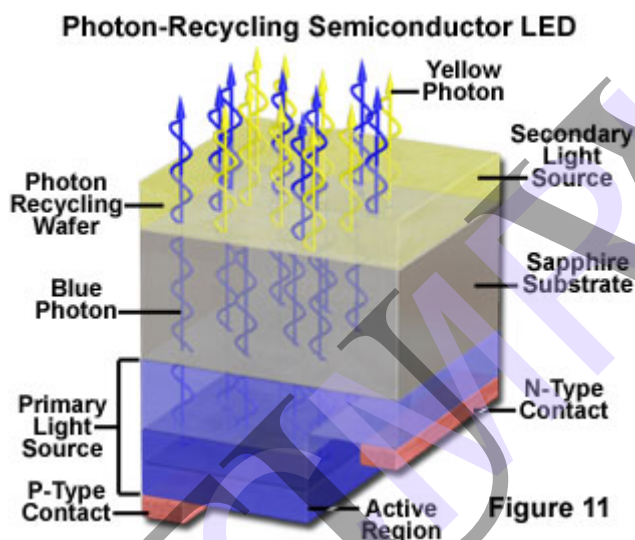

Because white light can be created by several different mechanisms, utilizing white LEDs in a particular application requires consideration of the suitability of the method employed to generate the light. Although the perceived color of light emitted by various techniques may be similar, its effect on color rendering, or the result of filtration of the light, for example, may be entirely different. White light created through broadband emission, through mixing of two complementary colors in a dichromatic source, or by mixing of three colors in a trichromatic source, can be located at different coordinates on the chromaticity diagram and have different color temperatures with respect to illuminants designated as standards by the CIE.

### Photodiode

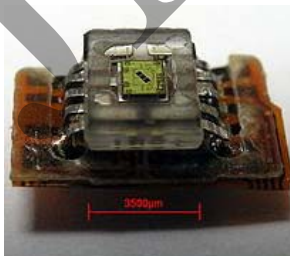

Photodetector from a CD-ROM Drive. 3 photodiodes are visible.

A **photodiode** is a type of photodetector capable of converting light into either current or voltage, depending upon the mode of operation.

Photodiodes are similar to regular semiconductor diodes except that they may be either exposed (to detect vacuum UV or X-rays) or packaged with a window or optical fiber connection to allow light to reach the sensitive part of the device. Many diodes designed for use specifically as a photodiode will also use a PIN junction rather than the typical PN junction.

### Polarity



Photodiode schematic symbol

Some photodiodes will look like the picture to the right, that is, similar to a light emitting diode. They will have two leads, or wires, coming from the bottom. The shorter end of the two is the cathode, while the longer end is the anode. See below for a schematic drawing of the anode and cathode side. Under forward bias, conventional current will pass from the anode to the cathode, following the arrow in the symbol. Photocurrent flows in the opposite direction.

### Principle of operation

A photodiode is a PN junction or PIN structure. When a photon of sufficient energy strikes the diode, it excites an electron, thereby creating a mobile electron and a positively charged electron hole. If the absorption occurs in the junction's depletion region, or one diffusion length away from it, these carriers are swept from the junction by the built-in field of the depletion region. Thus holes move toward the anode, and electrons toward the cathode, and a photocurrent is produced.

**Photovoltaic mode** When used in zero bias or photovoltaic mode, the flow of photocurrent out of the device is restricted and a voltage builds up. The diode becomes forward biased and "dark current" begins to flow across the junction in the direction opposite to the photocurrent. This mode is responsible for the photovoltaic effect, which is the basis for solar cells—in fact, a solar cell is just a large area photodiode.

#### Photoconductive mode

In this mode the diode is often reverse biased, dramatically reducing the response time at the expense of increased noise. This increases the width of the depletion layer, which decreases the junction's capacitance resulting in faster response times. The reverse bias induces only a small amount of current (known as saturation or back current) along its direction while the photocurrent remains virtually the same. The photocurrent is linearly proportional to the illuminance. Although this mode is faster, the photoconductive mode tends to exhibit more electronic noise. The leakage current of a good PIN diode is so low ( $< 1\text{nA}$ ) that the Johnson–Nyquist noise of the load resistance in a typical circuit often dominates.

### Applications

P-N photodiodes are used in similar applications to other photodetectors, such as photoconductors, charge-coupled devices, and photomultiplier tubes.

Photodiodes are used in consumer electronics devices such as compact disc players, smoke detectors, and the receivers for remote controls in VCRs and televisions.

In other consumer items such as camera light meters, clock radios (the ones that dim the display when it's dark) and street lights, photoconductors are often used rather than photodiodes, although in principle either could be used. Photodiodes are often used for accurate measurement of light intensity in science and industry. They generally have a better, more linear response than photoconductors. They are also widely used in various medical applications, such as detectors for computed tomography (coupled with scintillators) or instruments to analyze samples (immunoassay). They are also used in pulse oximeters.

PIN diodes are much faster and more sensitive than ordinary p-n junction diodes, and hence are often used for optical communications and in lighting regulation. P-N photodiodes are not used to measure extremely low light intensities. Instead, if high sensitivity is needed,

avalanche photodiodes, intensified charge-coupled devices or photomultiplier tubes are used for applications such as astronomy, spectroscopy, night vision equipment and laser rangefinding.

### Comparison with photomultipliers Advantages compared to photomultipliers:

Excellent linearity of output current as a function of incident light  
Spectral response from 190 nm to 1100 nm (silicon), longer wavelengths with other semiconductor materials  
Low noise Ruggedized to mechanical stress Low cost  
Compact and light weight Long lifetime High quantum efficiency, typically 80%  
No high voltage required

### Disadvantages compared to photomultipliers:

Small area No internal gain (except avalanche photodiodes, but their gain is typically  $10^2$ – $10^3$  compared to up to  $10^8$  for the photomultiplier) Much lower overall sensitivity  
Photon counting only possible with specially designed, usually cooled photodiodes, with special electronic circuits Response time for many designs is slower

### P-N vs. P-I-N photodiodes

Due to the intrinsic layer, a PIN photodiode must be reverse biased ( $V_r$ ). The  $V_r$  increases the depletion region allowing a larger volume for electron-hole pair production, and reduces the capacitance thereby increasing the bandwidth. The  $V_r$  also introduces noise current, which reduces the S/N ratio. Therefore, a reverse bias is recommended for higher bandwidth applications and/or applications where a wide dynamic range is required. A PN photodiode is more suitable for lower light applications because it allows for unbiased operation.

### A simple model of a photodiode

The PD can be connected directly to an ammeter, permitting the most sensitive measurement of the light power.

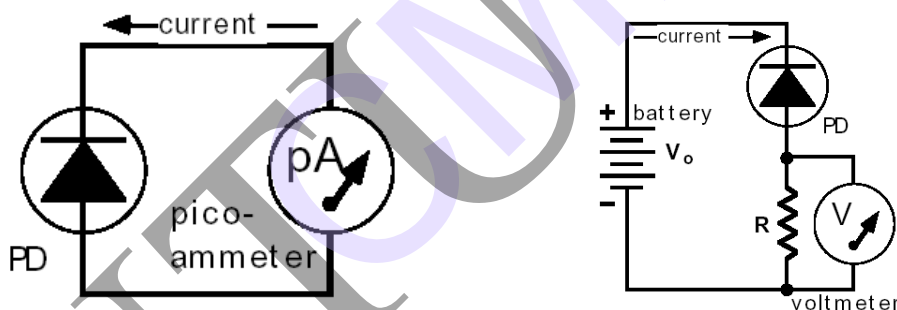

The diode can also be reverse biased to measure higher powers at faster speeds.

In either mode of operation, the photocurrent  $I$  is proportional to the power  $P$  of the light illuminating the photodiode.  $I = K_{PD} P$ , where  $K_{PD}$  is the responsivity of the photodiode.  $K_{PD}$  depends on the diode construction, the wavelength of the light, and on the temperature. The photodiode is a quantum device. Almost every incident photon generates an electron-hole charge pair. We therefore have  $I = e N Q$  where  $Q$  is the quantum efficiency and  $e$  is the magnitude of the electron's charge.  $Q$  is less than or equal to 100 %. The optical power is equal to the number of photons per second,  $N$ , times the energy per photon,  $E = hc/\lambda$ .  $P = N E = Nhc/\lambda$  The PD responsivity therefore is given by  $K_{PD} = Qe\lambda/(hc)$ .

### Introduction to Liquid Crystal Displays



The most common application of liquid crystal technology is in liquid crystal displays (LCDs). From the ubiquitous wrist watch and pocket calculator to an advanced VGA computer screen, this type of display has evolved into an important and versatile interface. A liquid crystal display consists of an array of tiny segments (called pixels) that can be manipulated to present information. This basic idea is common to all displays, ranging from simple calculators to a full color LCD television. Why are liquid crystal displays important? The first factor is size. As will be shown in the following sections, an LCD consists primarily of two glass plates with some liquid crystal material between them. There is no bulky picture tube. This makes LCDs practical for applications where size (as well as weight) are important. In general, LCDs use much less power than their cathode-ray tube (CRT) counterparts. Many LCDs are reflective, meaning that they use only ambient light to illuminate the display. Even displays that do require an external light source (i.e. computer displays) consume much less power than CRT devices. Liquid crystal displays do have drawbacks, and these are the subject of intense research. Problems with viewing angle, contrast ratio, and response time still need to be solved before the LCD replaces the cathode-ray tube. However with the rate of technological innovation, this day may not be too far into the future.

We will restrict this discussion to traditional nematic LCDs since the major technological advances have been developed for this group of devices. Other LC applications, such as those employing polymer stabilization of LC structure, are discussed in the appropriate section covering those materials.

### ***Liquid Crystal***

Ordinary fluids are isotropic in nature: they appear optically, magnetically, electrically, etc. to be the same from any perspective. Although the molecules which comprise the fluid are generally anisometric in shape, this anisometry *generally* plays little role in anisotropic macroscopic behavior (aside from viscosity). Nevertheless, there exists a large class of *highly* anisometric molecules which gives rise to unusual, fascinating, and potentially technologically relevant behavior. There are many interesting candidates for study, including polymers, micelles, microemulsions, and materials of biological significance, such as DNA and membranes. Although at times we have investigated all of these materials, our primary effort centers on liquid crystals. Liquid crystals are composed of moderate size organic molecules which tend to be elongated and shaped like a cigar, although we have studied, and the literature is full of variety of other, highly exotic shapes as well. Because of their elongated shape, under appropriate conditions the molecules can exhibit orientational order, such that all the axes line up in a particular direction. In consequence, the bulk order has profound influences on the way light and electricity behave in the material. For example, if the direction of the orientation varies in space, the orientation of the light (i.e., the polarization) can follow this variation. A well-known application of this phenomenon is the ubiquitous liquid crystal display, now comprising a \$15b annual industry world-wide. Under other conditions the molecules may form a stack of layers along one direction, but remain liquid like (in terms of the absence of translational order) within the layers. As the system changes from one of these phases to another, a variety of physical parameters such as susceptibility and heat capacity, will exhibit "pretransitional behavior." Based solely on symmetry, this behavior may be related to other physical systems, such as superconductivity, magnetism, or superfluidity; this is the so-called "universality" of these phase transitions.



Using a battery of optical techniques, in addition to dielectric and certain surface probes, our research centers on the role of symmetry on liquid crystalline phases and phase transitions, how these systems behave in the presence of intense magnetic and electric fields, and the effects of confining these materials in spaces not much larger than the molecules themselves. By observing this behavior, we learn not only about the particular material under consideration, but about the global properties of anisotropic fluids and their relationships to other physical systems. Finally, we should point out that although our research is primarily fundamental in nature, determining critical exponents, surface potentials, induced polarizations, etc., a small but important component of our effort involves technology. For example, we have developed a new liquid crystal display architecture which is being developed for commercialization by American industry. This is a symbiotic approach to research, and has been an intellectual stimulation to our effort.

## Liquid crystal display

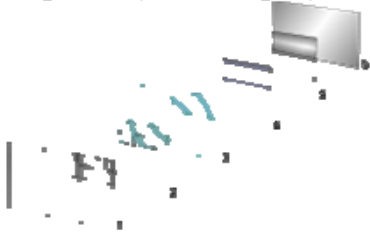

Reflective twisted nematic liquid crystal display.

Polarizing filter film with a vertical axis to polarize light as it enters.

Glass substrate with ITO electrodes. The shapes of these electrodes will determine the shapes that will appear when the LCD is turned ON. Vertical ridges etched on the surface are smooth.

Twisted nematic liquid crystal. Glass substrate with common electrode film (ITO) with horizontal ridges to line up with the horizontal filter. Polarizing filter film with a horizontal axis to block/pass light. Reflective surface to send light back to viewer. (In a backlit LCD, this layer is replaced with a light source.)

A **liquid crystal display (LCD)** is a thin, flat panel used for electronically displaying information such as text, images, and moving pictures. Its uses include monitors for computers, televisions, instrument panels, and other devices ranging from aircraft cockpit displays, to every-day consumer devices such as video players, gaming devices, clocks, watches, calculators, and telephones. Among its major features are its lightweight construction, its portability, and its ability to be produced in much larger screen sizes than are practical for the construction of cathode ray tube (CRT) display technology. Its low electrical power consumption enables it to be used in battery-powered electronic equipment. It is an electronically-modulated optical device made up of any number of pixels filled with liquid crystals and arrayed in front of a light source (backlight) or reflector to produce images in color or monochrome. The earliest discovery leading to the development of LCD technology, the discovery of liquid crystals, dates from 1888. By 2008, worldwide sales of televisions with LCD screens had surpassed the sale of CRT units.



LCD alarm clock

Each pixel of an LCD typically consists of a layer of molecules aligned between two transparent electrodes, and two polarizing filters, the axes of transmission of which are (in most of the cases) perpendicular to each other. With no actual liquid crystal between the polarizing filters, light passing through the first filter would be blocked by the second

(crossed) polarizer. The surface of the electrodes that are in contact with the liquid crystal material are treated so as to align the liquid crystal molecules in a particular direction. This treatment typically consists of a thin polymer layer that is unidirectionally rubbed using, for example, a cloth. The direction of the liquid crystal alignment is then defined by the direction of rubbing. Electrodes are made of a transparent conductor called Indium Tin Oxide (ITO). Before applying an electric field, the orientation of the liquid crystal molecules is determined by the alignment at the surfaces of electrodes. In a twisted nematic device (still the most common liquid crystal device), the surface alignment directions at the two electrodes are perpendicular to each other, and so the molecules arrange themselves in a helical structure, or twist. This reduces the rotation of the polarization of the incident light, and the device appears grey. If the applied voltage is large enough, the liquid crystal molecules in the center of the layer are almost completely untwisted and the polarization of the incident light is not rotated as it passes through the liquid crystal layer. This light will then be mainly polarized perpendicular to the second filter, and thus be blocked and the pixel will appear black. By controlling the voltage applied across the liquid crystal layer in each pixel, light can be allowed to pass through in varying amounts thus constituting different levels of gray.



### **Energy efficiency**

Among newer TV models, LCDs require less energy on average than their plasma counterparts. A 42-inch LCD consumes 203 watts on average compared to 271 watts consumed by a 42-inch plasma display. *(This information is outdated - current plasma tv's such as the panasonic TH-42 X10 consume between 80-200W. When measuring the average powerconsumption, it is usually between 120W and 150W.)* Energy use per inch is another metric for comparing different display technologies. CRT technology is more efficient per square inch of display area, using 0.23 watts/square inch, while LCDs require 0.27 watts/square inch. Plasma displays are on the high end at 0.36 watts/square inch and DLP/rear projection TVs represent the low end at 0.14 watts/square inch.

Bistable displays do not consume any power when displaying a fixed image, but require a notable amount of power for changing displayed image.

## UNIT - VI

### 10. DIELECTRIC PROPERTIES

**Introduction:** Dielectrics are insulating materials. In dielectrics, all the electrons are bound to their parent molecules and there are no free charges. Even with normal voltage or thermal energy, electrons are not released.

**Electric Dipole:** A system consisting of two equal and opposite charges separated by a distance is called electric dipole.

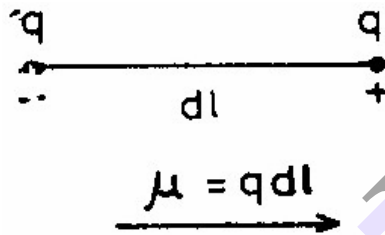

**Dipole moment:** The product of charge and distance between two charges is called dipole moment.

$$\text{i.e., } \mu = q \times dl$$

**Permittivity:** It is a quantity, which represents the dielectric property of a medium. Permittivity of a medium indicates the easily Polarisable nature of the material.

Units: Faraday / Meter or Coulomb / Newton-meter .

**Dielectric constant:** The dielectric characteristics are determined by the dielectric constant. The dielectric constant or relative permittivity of a medium is defined as the ratio between the permittivity of the medium to the permittivity of the free space.

$$\epsilon_r = \epsilon / \epsilon_0 = C / C_0 \quad \text{where}$$

$\epsilon$  is permittivity of the medium

$\epsilon_0$  is permittivity of the free space

$C$  is the capacitance of the capacitor with dielectric

$C_0$  is the capacitance of the capacitor without dielectric

Units: No Units.

**Capacitance:** The property of a conductor or system of conductor that describes its ability to store electric charge.

$$C = q / V = A \epsilon / d \quad \text{where}$$

$C$  is capacitance of capacitor

$q$  is charge on the capacitor plate

V is potential difference between plates  
 A is area of capacitor plate  
 $\epsilon$  is permittivity of medium  
 d is distance between capacitor plates

Units: Farad .

**Polarizability ( $\alpha$ )** : When the strength of the electric field E is increased the strength of the induced dipole  $\mu$  also increases . Thus the induced dipole moment is proportional to the intensity of the electric field.

$\mu = \alpha E$  where  $\alpha$  the constant of proportionality is called polarizability  
 .It can be defined as induced dipole moment per unit electric field.

$$\alpha = \mu / E$$

Units: Farad – meter<sup>2</sup>

**Polarization Vector ( P )** : The dipole moment per unit volume of the dielectric material is called polarization vector **P** .if  $\mu$  is the average dipole moment per molecule and N is the number of molecules per unit volume then polarization vector

$$\mathbf{P} = N \mu$$

The dipole moment per unit volume of the solid is the sum of all the individual dipole moments within that volume and is called the polarization of the solid.

**Electric Flux Density or Electric Displacement (D)**: The Electric Flux Density or Electric Displacement at a point in the material is given by

$$D = \epsilon_r \epsilon_0 E \text{ -----(1) where}$$

E is electric field strength

$\epsilon_r$  is relative permittivity of material

$\epsilon_0$  is permittivity of free space

As polarization measures additional flux density arising from the presence of the material as compared to free space, it has same units as D.

$$\text{Hence } D = \epsilon_0 E + \mathbf{P} \text{ -----(2)}$$

$$\text{Since } D = \epsilon_0 \epsilon_r E$$

$$\epsilon_0 \epsilon_r E = \epsilon_0 E + \mathbf{P}$$

$$\mathbf{P} = \epsilon_0 \epsilon_r E - \epsilon_0 E$$

$$\mathbf{P} = \epsilon_0 (\epsilon_r - 1) E.$$

**Electric Susceptibility ( $\chi_e$ ):** The polarization  $\mathbf{P}$  is proportional to the total electric flux density  $\mathbf{E}$  and is in the same direction of  $\mathbf{E}$ . Therefore, the polarization vector can be written as

$$\mathbf{P} = \epsilon_0 \chi_e \mathbf{E}$$

$$\text{Therefore } \chi_e = \mathbf{P} / \epsilon_0 \mathbf{E} = \epsilon_0 (\epsilon_r - 1) \mathbf{E} / \epsilon_0 \mathbf{E}$$

$$\chi_e = (\epsilon_r - 1)$$

**Dielectric Strength:** It can be defined as the minimum voltage required for producing dielectric breakdown. Dielectric strength decreases with raising the temperature, humidity and age of the material.

**Various polarization Process:** polarization occurs due to several atomic mechanisms. When a specimen is placed in a d.c. electric field, polarization is due to four types of processes. They are

- (1) electronic polarization
- (2) ionic polarization
- (3) orientation polarization and
- (4) space charge polarization

**Electronic Polarization:** the process of producing electric dipoles which are oriented along the field direction is called polarization in dielectrics

Consider an atom placed inside an electric field. The centre of positive charge is displaced along the applied field direction while the centre of negative charge is displaced in the opposite direction. thus a dipole is produced.

The displacement of the positively charged nucleus and the negative electrons of an atom in opposite directions, on application of an electric field, result in electronic polarization.

Induced dipole moment

$$\boldsymbol{\mu} = \alpha_e \mathbf{E} \quad \text{or} \quad \boldsymbol{\mu} = \alpha_e \mathbf{E} \quad \text{where } \alpha_e \text{ is electronic polarizability}$$

Electronic polarizability is independent of temperature.

*Derivation:* Consider the nucleus of charge  $+Ze$  is surrounded by an electron cloud of charge  $-Ze$  distributed in a sphere of radius  $R$ .

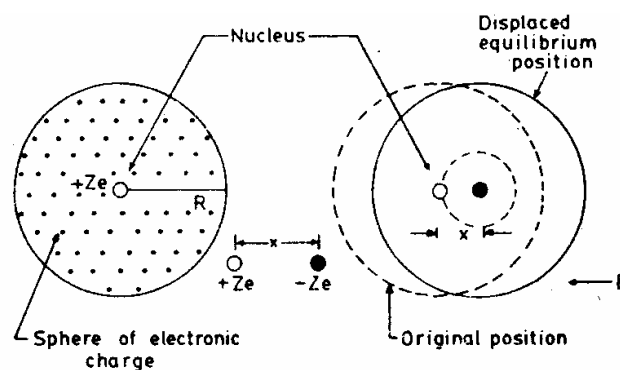

Charge density  $\rho$  is given by

$$\rho = -Ze / (4/3 \pi R^3) = -(3/4) (Ze / \pi R^3) \text{ -----(1)}$$

When an external field of intensity  $E$  is applied, the nucleus and electrons experiences Lorentz forces in opposite direction. Hence the nucleus and electron cloud are pulled apart.

Then Coulomb force develops between them, which tends to oppose the displacement. When Lorentz and coulomb forces are equal and opposite, equilibrium is reached.

Let  $x$  be the displacement

$$\text{Lorentz force} = -Ze E \text{ (since = charge } \times \text{ applied field)}$$

$$\text{Coulomb force} = Ze x \text{ [ charge enclosed in sphere of radius 'x' / } 4 \pi \epsilon_0 x^2 \text{ ]}$$

$$\text{Charge enclosed} = (4/3) \pi x^3 \rho$$

$$= (4/3) \pi x^3 [(-3/4) (Ze / \pi R^3)]$$

$$= -Ze x^3 / R^3$$

$$\text{Therefore Coulomb force} = (Ze)(-Ze x^3 / R^3) / 4 \pi \epsilon_0 x^2 = -Z^2 e^2 x / 4 \pi \epsilon_0 R^3$$

At equilibrium, Lorentz force = Coulomb force

$$\Rightarrow -Ze E = -Z^2 e^2 x / 4 \pi \epsilon_0 R^3$$

$$\Rightarrow E = -Ze x / 4 \pi \epsilon_0 R^3$$

$$\Rightarrow \text{or } x = 4 \pi \epsilon_0 R^3 E / Ze$$

Thus displacement of electron cloud is proportional to applied field.

The two charges  $+Ze$  and  $-Ze$  are separated by a distance ' $x$ ' under applied field constituting induced electric dipoles .

$$\text{Induced dipole moment } \mu_e = Ze x$$

$$\text{Therefore } \mu_e = Ze (4 \pi \epsilon_0 R^3 E / Ze) = 4 \pi \epsilon_0 R^3 E$$

Therefore  $\mu_e \propto E$ ,  $\mu_e = \alpha_e E$  where  $\alpha_e = 4 \pi \epsilon_0 R^3$  is electronic polarizability

The dipole moment per unit volume is called electronic polarization. It is independent of temperature.

$$\mathbf{P} = N \mu_e = N \alpha_e E \text{ where}$$

$$N \text{ is Number of atoms / m}^3$$

$$\mathbf{P}_e = N (4 \pi \epsilon_0 R^3 E) = 4 \pi \epsilon_0 R^3 N E \text{ where}$$

$R$  is radius of atom

Electric Susceptibility  $\chi = \mathbf{P} / \epsilon_0 E$

Therefore  $\mathbf{P} = \epsilon_0 E \chi$

$$\mathbf{P} = (4 \Pi R^3 N) \epsilon_0 E \quad \text{where } \chi = 4 \Pi R^3 N$$

Also  $\mathbf{P}_e = \epsilon_0 E (\epsilon_r - 1) = N \alpha_e E$

$$\text{Or } \epsilon_r - 1 = N \alpha_e / \epsilon_0$$

Hence  $\alpha_e = \epsilon_0 (\epsilon_r - 1) / N$ .

**Ionic Polarization:** It is due to the displacement of cat ions and anions in opposite directions and occurs in an ionic solid .

Consider a NaCl molecule. Suppose an electric field is applied in the positive direction . The positive ion moves by  $x_1$  and the negative ion moves by  $x_2$

Let M is mass of positive ion

M is mass of negative ion

$x_1$  is displacement of positive ion

$x_2$  is displacement of negative ion

$$\text{Total displacement } x = x_1 + x_2 \text{ -----(1)}$$

$$\text{Lorentz force on positive ion } = + e E \text{ -----(2)}$$

$$\text{Lorentz force on negative ion } = - e E \text{ -----(3)}$$

$$\text{Restoring force on positive ion } = -k_1 x_1 \text{ -----(2 a)}$$

$$\text{Restoring force on negative ion } = +k_2 x_2 \text{ -----(3 a) where } k_1, k_2 \text{ Restoring force constants}$$

At equilibrium, Lorentz force and restoring force are equal and opposite

$$\text{For positive ion, } e E = k_1 x_1$$

$$\text{For negative ion, } e E = k_2 x_2 \quad ] \text{ ----- (4)}$$

Where  $k_1 = M \omega_0^2$  &  $k_2 = m \omega_0^2$  where  $\omega_0$  is angular velocity of ions

$$\text{Therefore } x = x_1 + x_2 = (e E / \omega_0^2) [ 1/M + 1/m ] \text{ -----(5)}$$

From definition of dipole moment

$\mu = \text{charge} \times \text{distance of separation}$

$$\mu = e x = (e^2 E / \omega_0^2) [ 1/M + 1/m ] \text{ -----(6)}$$



But  $\mu \propto E$  or  $\mu = \alpha_i E$

Therefore  $\alpha_i = (e^2 / \omega_0^2) [1/M + 1/m]$

This is ionic polarizability.

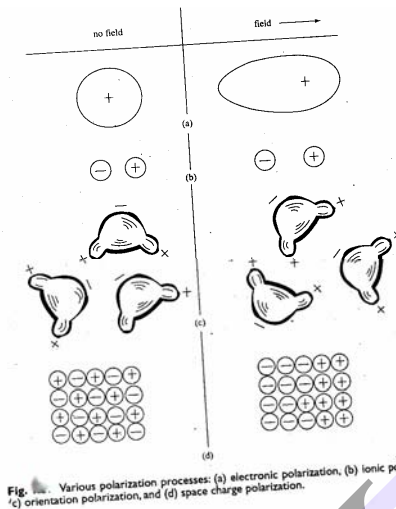

Fig. 1.1. Various polarization processes: (a) electronic polarization, (b) ionic polarization, (c) orientation polarization, and (d) space charge polarization.

### Orientational Polarization:

In methane molecule, the centre of negative and positive charges coincides, so that there is no permanent dipole moment. On the other hand, in certain molecules such as  $\text{CH}_3\text{Cl}$ , the positive and negative charges do not coincide. Even in the absence of an electric field, this molecule carries a dipole moment, they tend to align themselves in the direction of applied field. The polarization due to such alignment is called orientation polarization. It is dependent on temperature. With increase of temperature the thermal energy tends to randomize the alignment.

$$\begin{aligned} \text{Orientational polarization } P_o &= N\mu = N\mu_0 E / 3kT \\ &= N \alpha_0 E \end{aligned}$$

Therefore Orientational polarizability  $\alpha_0 = P_o / NE = \mu_0^2 / 3kT$

Thus orientational polarizability  $\alpha_0$  is inversely proportional to absolute temperature of material.

**Internal field or Local field or Lorentz field:** Internal field is the total electric field at atomic site.

$$\text{Internal field } A = E_1 + E_2 + E_3 + E_4 \quad \text{----- (I) where}$$

$E_1$  is field intensity due to charge density on plates

$E_2$  is charge density induced on two sides of dielectric

$E_3$  is field intensity due to other atoms in cavity and

$E_4$  is field intensity due to polarization charges on surface of cavity



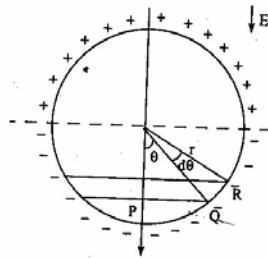
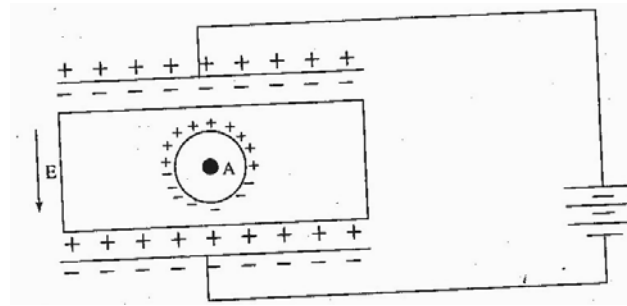

Field  $E_1$  :  $E_1$  is field intensity due to charge density on plates

From the field theory

$$E_1 = D / \epsilon_0$$

$$D = P + \epsilon_0 E$$

$$\text{Therefore } E_1 = P + \epsilon_0 E / \epsilon_0 = E + P / \epsilon_0 \text{ -----(1)}$$

Field  $E_2$  :  $E_2$  is the field intensity at A due to charge density induced on two sides of dielectric

$$\text{Therefore } E_2 = - P / \epsilon_0 \text{ -----(2)}$$

Field  $E_3$  :  $E_3$  is field intensity at A due to other atoms contained in the cavity and for a cubic structure,

$$E_3 = 0 \text{ because of symmetry. ----- (3)}$$

Field  $E_4$ :  $E_4$  is field intensity due to polarization charges on surface of cavity and was calculated by Lorentz in the following way:

If  $dA$  is the surface area of the sphere of radius  $r$  lying between  $\theta$  and  $\theta + d\theta$ , where  $\theta$  is the direction with reference to the direction of applied force.

$$\text{Then } dA = 2 \Pi (PQ) (QR)$$

$$\text{But } \sin \theta = PQ / r \Rightarrow PQ = r \sin \theta$$

$$\text{And } d\theta = QR / r \Rightarrow QR = r d\theta$$

$$\text{Hence } dA = 2 \Pi (r \sin \theta) (r d\theta) = 2 \Pi r^2 \sin \theta d\theta$$

Charge on surface  $dA$  is  $dq = P \cos \theta dA$  ( $\cos \theta$  is normal component)

$$dq = P \cos \theta (2 \Pi r^2 \sin \theta d\theta) = P (2 \Pi r^2 \sin \theta \cos \theta d\theta)$$

The field due to the charge  $dq$  at  $A$ , is denoted by  $dE_4$  in direction  $\theta = 0$

$$dE_4 = dq \cos \theta / 4 \Pi \epsilon_0 r^2 = P (2 \Pi r^2 \sin \theta \cos \theta d\theta) \cos \theta$$

$$dE_4 = P \sin \theta \cos^2 \theta d\theta / 2 \epsilon_0$$

$$\int dE_4 = P / 2 \epsilon_0 \int_0^\Pi \sin \theta \cos^2 \theta d\theta = P / 2 \epsilon_0 \int_0^\Pi \cos^2 \theta d(-\cos \theta)$$

Let  $\cos \theta = x$

$$\int dE_4 = -P / 2 \epsilon_0 \int_0^\Pi x^2 dx$$

$$\text{Therefore } E_4 = -P / 2 \epsilon_0 [x^3 / 3]_0^\Pi$$

$$= -P / 2 \epsilon_0 [\cos^3 \theta / 3]_0^\Pi = -P / 6 \epsilon_0 [-1 - 1] = P / 3 \epsilon_0 \text{ ----- (4)}$$

Local field  $E_i = E_1 + E_2 + E_3 + E_4$

$$= E + P / \epsilon_0 - P / \epsilon_0 + 0 + P / 3 \epsilon_0$$

$$= E + P / 3 \epsilon_0$$

### Clausius – Mosotti Relation:

Let us consider the elemental dielectric having cubic structure. Since there are no ions and permanent dipoles in these materials, their ionic polarizability  $\alpha_i$  and orientational polarizability  $\alpha_0$  are zero.

$$\text{i.e. } \alpha_i = \alpha_0 = 0$$

$$\text{Hence polarization } P = N \alpha_e E_i$$

$$= N \alpha_e (E + P / 3 \epsilon_0)$$

$$\text{i.e. } P [1 - N \alpha_e / 3 \epsilon_0] = N \alpha_e E$$

$$P = N \alpha_e E / [1 - N \alpha_e / 3 \epsilon_0] \text{ -----} \rightarrow 1$$

$$D = P + \epsilon_0 E$$

$$P = D - \epsilon_0 E$$

Dividing on both sides by E

$$P / E = D / E - \epsilon_0 = \epsilon - \epsilon_0 = \epsilon_0 \epsilon_r - \epsilon_0$$

$$P = E \epsilon_0 (\epsilon_r - 1) \text{ -----} \rightarrow 2$$

From eqn 1 and 2 , we get

$$P = E \epsilon_0 (\epsilon_r - 1) = N \alpha_e E / [ 1 - N \alpha_e / 3 \epsilon_0 ]$$

$$[ 1 - N \alpha_e / 3 \epsilon_0 ] = N \alpha_e / \epsilon_0 (\epsilon_r - 1)$$

$$1 = N \alpha_e / 3 \epsilon_0 + N \alpha_e / \epsilon_0 (\epsilon_r - 1)$$

$$1 = (N \alpha_e / 3 \epsilon_0) ( 1 + 3 / (\epsilon_r - 1) )$$

$$1 = (N \alpha_e / 3 \epsilon_0) [ (\epsilon_r - 1 + 3) / (\epsilon_r - 1) ]$$

$$1 = (N \alpha_e / 3 \epsilon_0) [ (\epsilon_r + 2) / (\epsilon_r - 1) ]$$

$$(\epsilon_r + 2) / (\epsilon_r - 1) = N \alpha_e / 3 \epsilon_0 \quad \text{Where } N \text{ - no of molecules per unit volume}$$

This is Clausius – Mosotti Relation.

**Dielectric Breakdown :** The dielectric breakdown is the sudden change in state of a dielectric material subjected to a very high electric field , under the influence of which , the electrons are lifted into the conduction band causing a surge of current , and the ability of the material to resist the current flow suffers a breakdown .

Or

When a dielectric material loses its resistivity and permits very large current to flow through it, then the phenomenon is called dielectric breakdown.

There are many factors for dielectric breakdown which are (1) Intrinsic breakdown (2) Thermal breakdown (3) Discharge breakdown (4) Electro Chemical breakdown (5) Defect breakdown.

(1) **Intrinsic breakdown:** The dielectric strength is defined as the breakdown voltage per unit thickness of the material. When the applied electric field is large, some of the electrons in the valence band cross over to the conduction band across the large forbidden energy gap giving rise to large conduction currents. The liberation or movement of electrons from valence band is called field emission of electrons and the breakdown is called the intrinsic breakdown or zener breakdown.

The number of covalent bonds broken and the number of charge carriers released increases enormously with time and finally dielectric breakdown occurs. This type of breakdown is called Avalanche breakdown.

- (2) **Thermal breakdown:** It occurs in a dielectric when the rate of heat generation is greater than the rate of dissipation. Energy due to the dielectric loss appears as heat. If the rate of generation of heat is larger than the heat dissipated to the surrounding, the temperature of the dielectric increases which eventually results in local melting. Once melting starts, that particular region becomes highly conductive, enormous current flows through the material and dielectric breakdown occurs.

Thus thermal breakdown occurs at very high temperatures. Since the dielectric loss is directly proportional to the frequency, for a.c fields, breakdown occurs at relatively lower field strengths.

- (3) **Discharge breakdown:** Discharge breakdown is classified as external or internal. External breakdown is generally caused by a glow or corona discharge. Such discharges are normally observed at sharp edges of electrodes. It causes deterioration of the adjacent dielectric medium. It is accompanied by the formation of carbon so that the damaged areas become conducting leading to power arc and complete failure of the dielectric. Dust or moisture on the surface of the dielectric may also cause external discharge breakdown. Internal breakdown occurs when the insulator contains blocked gas bubbles. If large number of gas bubbles is present, this can occur even at low voltages.
- (4) **Electro Chemical breakdown:** Chemical and electro chemical breakdown are related to thermal breakdown. When temperature rises, mobility of ions increases and hence electrochemical reaction takes place. When ionic mobility increases leakage current also increases and this may lead to dielectric breakdown. Field induced chemical reaction gradually decreases the insulation resistance and finally results in breakdown.
- (5) **Defect breakdown:** if the surface of the dielectric material has defects such as cracks and porosity, then impurities such as dust or moisture collect at these discontinuities leading to breakdown. Also if it has defect in the form of strain in the material, that region will also break on application of electric field.

### Frequency dependence of polarizability:

On application of an electric field, polarization process occurs as a function of time. The polarization  $P(t)$  as a function of time. The polarization  $P(t)$  as a function of time  $t$  is given by

$$P(t) = P[1 - \exp(-t/t_r)]$$

Where  $P$  – max. Polarization attained on prolonged application of static field.

$t_r$  - relaxation time for particular polarization process

The relaxation time  $t_r$  is a measure of the time scale of polarization process. It is the time taken for a polarization process to reach 0.63 of the max. value.

Electronic polarization is extremely rapid. Even when the frequency of the applied voltage is very high in the optical range ( $\approx 10^{15}$  Hz), electronic polarization occurs during every cycle of the applied voltage.

Ionic polarization is due to displacement of ions over a small distance due to the applied field. Since ions are heavier than electron cloud, the time taken for displacement is larger. The frequency with which ions are displaced is of the same order as the lattice vibration frequency ( $\approx 10^{13}$  Hz). Hence, at optical frequencies, there is no ionic polarization. If the frequency of the applied voltage is less than  $10^{13}$  Hz, the ions respond.

Orientation polarization is even slower than ionic polarization. The relaxation time for orientation polarization in a liquid is less than that in a solid. Orientation polarization occurs, when the frequency of applied voltage is in audio range ( $10^{10}$  Hz).

Space charge polarization is the slowest process, as it involves the diffusion of ions over several interatomic distances. The relaxation time for this process is related to frequency of ions under the influence of applied field. Space charge polarization occurs at power frequencies (50-60 Hz).

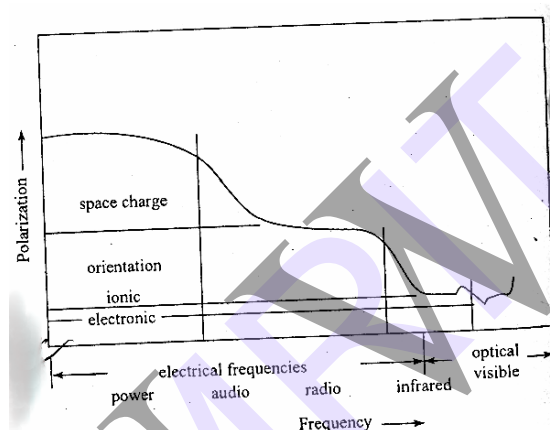

**Piezo – Electricity:** These materials have the property of becoming electrically polarized when mechanical stress is applied. This property is known as Piezo – electric effect has an inverse .According to inverse piezo electric effect, when an electric stress or voltage is applied, the material becomes strained. The strain is directly proportional to the applied field E.

When piezo electric crystals are subjected to compression or tension, opposite kinds of charges are developed at the opposite faces perpendicular to the direction of applied force. The charges produced are proportional to the applied force.

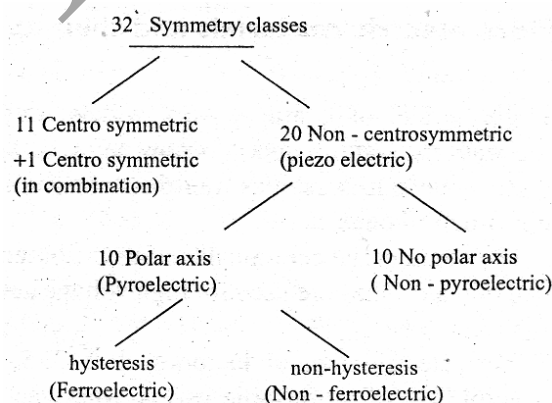

**Piezo – Electric Materials and Their Applications:** Single crystal of quartz is used for filter, resonator and delay line applications. Natural quartz is now being replaced by synthetic material.

Rochelle salt is used as transducer in gramophone pickups, ear phones, hearing aids, microphones etc. the commercial ceramic materials are based on barium titanate, lead zirconate and lead titanate. They are used for high voltage generation (gas lighters), accelerometers, transducers etc.

Piezo electric semiconductors such as GaS, ZnO & CdS are used as amplifiers of ultrasonic waves.

**Ferro electricity:** Ferro electric materials are an important group not only because of intrinsic Ferro electric property, but because many possess useful piezo electric, birefringent and electro optical properties.

The intrinsic Ferro electric property is the possibility of reversal or change of orientation of the polarization direction by an electric field. This leads to hysteresis in the polarization P, electric field E relation, similar to magnetic hysteresis. Above a critical temperature, the Curie point  $T_c$ , the spontaneous polarization is destroyed by thermal disorder. The permittivity shows a characteristic peak at  $T_c$ .

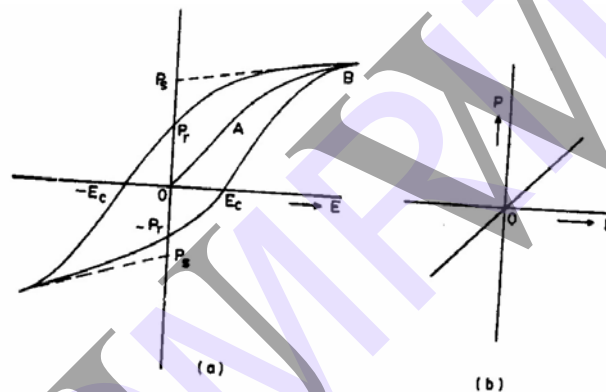

**Pyroelectricity:** It is the change in spontaneous polarization when the temperature of specimen is changed.

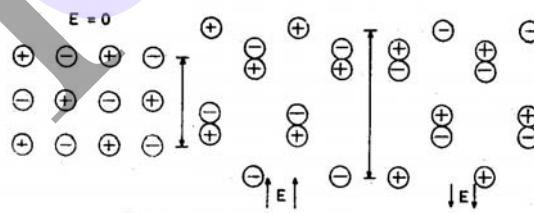

Fig. Displacements of the ions under an electric field

Pyroelectric coefficient ' $\lambda$ ' is defined as the change in polarization per unit temperature change of specimen.

$$\lambda = dP / dT$$

change in polarization results in change in external field and also changes the surface.

**Required Qualities of Good Insulating Materials:** The required qualities can be classified as under electrical, mechanical, thermal and chemical applications.

- i) Electrical: 1. electrically the insulating material should have high electrical resistivity and high dielectric strength to withstand high voltage.  
2. The dielectric losses must be minimum.  
3. Liquid and gaseous insulators are used as coolants. For example transformer oil, hydrogen and helium are used both as insulators and coolant.
- ii) Mechanical: 1. insulating materials should have certain mechanical properties depending on the use to which they are put.  
2. When used for electric machine insulation, the insulator should have sufficient mechanical strength to withstand vibration.
- iii) Thermal: Good heat conducting property is also desirable in such cases. The insulators should have small thermal expansion and it should be non-ignitable.
- iv) Chemical: 1. chemically, the insulators should be resistant to oils, liquids, gas fumes, acids and alkali's.  
2. The insulators should be water proof since water lowers the insulation resistance and the dielectric strength.



## 11. MAGNETIC PROPERTIES

**Introduction :** The basic aim in the study of the subject of magnetic materials is to understand the effect of an external magnetic field on a bulk material, and also to account for its specific behavior. A dipole is an object that a magnetic pole is on one end and an equal and opposite second magnetic dipole is on the other end.

A bar magnet can be considered as a dipole with a north pole at one end and South Pole at the other. If a magnet is cut into two, two magnets or dipoles are created out of one. This sectioning and creation of dipoles can continue to the atomic level. Therefore, the source of magnetism lies in the basic building block of all matter i.e. the atom.

Consider electric current flowing through a conductor. When the electrons are flowing through the conductor, a magnetic field is formed around the conductor. A magnetic field is produced whenever an electric charge is in motion. The strength of the field is called the **magnetic moment**.

Magnetic materials are those which can be easily magnetized as they have permanent magnetic moment in the presence of an applied magnetic field. Magnetism arises from the magnetic dipole moments. It is responsible for producing magnetic influence of attraction or repulsion.

**Magnetic dipole :** it is a system consisting of two equal and opposite magnetic poles separated by a small distance of '2l' metre.

**Magnetic Moment ( $\mu_m$ ) :** It is defined as the product of the pole strength (m) and the distance between the two poles (2l) of the magnet.

$$\text{i.e.} \dots \mu_m = (2l) m$$

Units: Ampere – metre<sup>2</sup>

**Magnetic Flux Density or Magnetic Induction (B):** It is defined as the number of magnetic lines of force passing perpendicularly through unit area.

$$\text{i.e.} \dots \mathbf{B} = \text{magnetic flux} / \text{area} = \Phi / A$$

Units: Weber / metre<sup>2</sup> or Tesla.

### **Permeability:**

**Magnetic Field Intensity (H):** The magnetic field intensity at any point in the magnetic field is the force experienced by a unit north pole placed at that point.

Units: Ampere / meter

The magnetic induction B due to magnetic field intensity H applied in vacuum is related by

$$\mathbf{B} = \mu_0 \mathbf{H} \quad \text{where } \mu_0 \text{ is permeability of free space} = 4 \pi \times 10^{-7} \text{ H / m}$$

If the field is applied in a medium, the magnetic induction in the solid is given by

$$\mathbf{B} = \mu \mathbf{H} \quad \text{where } \mu \text{ is permeability of the material in the medium}$$

$$\mu = B / H$$

Hence magnetic Permeability  $\mu$  of any material is the ratio of the magnetic induction to the applied magnetic field intensity. The ratio of  $\mu / \mu_0$  is called the relative permeability ( $\mu_r$ ).

$$\mu_r = \mu / \mu_0$$

Therefore 
$$\mathbf{B} = \mu_0 \mu_r \mathbf{H}$$

**Magnetization:** It is the process of converting a non – magnetic material into a magnetic material. The intensity of magnetization (M) of a material is the magnetic moment per unit volume. The intensity of magnetization is directly related to the applied field H through the susceptibility of the medium ( $\chi$ ) by

$$\chi = M / H \quad \text{-----(1)}$$

The magnetic susceptibility of a material is the ratio of the intensity of magnetization produced to the magnetic field intensity which produces the magnetization. It has no units.

We know

$$\mathbf{B} = \mu \mathbf{H}$$

$$= \mu_0 \mu_r \mathbf{H}$$

i.e 
$$\mathbf{B} = \mu_0 \mu_r \mathbf{H} + \mu_0 \mathbf{H} - \mu_0 \mathbf{H}$$

$$= \mu_0 \mathbf{H} + \mu_0 \mathbf{H} (\mu_r - 1)$$

$$= \mu_0 \mathbf{H} + \mu_0 \mathbf{M} \quad \text{where M is magnetization} = \mathbf{H} (\mu_r - 1)$$

i.e 
$$\mathbf{B} = \mu_0 (\mathbf{H} + \mathbf{M}) \quad \text{-----(2)}$$

The first term on the right side of eqn (2) is due to external field. The second term is due to the magnetization.

Hence 
$$\mu_0 = \mathbf{B} / \mathbf{H} + \mathbf{M}$$

Relative Permeability ,

$$\mu_r = \mu / \mu_0 = (\mathbf{B} / \mathbf{H}) / (\mathbf{B} / \mathbf{H} + \mathbf{M}) = \mathbf{H} + \mathbf{M} / \mathbf{H} = 1 + \mathbf{M} / \mathbf{H}$$

$$\mu_r = 1 + \chi \quad \text{-----(3)}$$

The magnetic properties of all substances are associated with the orbital and spin motions of the electrons in their atoms. Due to this motion, the electrons become elementary magnets of the substance. In few materials these elementary magnets are able to strengthen the applied magnetic field, while in few others, they orient themselves such that the applied magnetic field is weakened.

**Origin of Magnetic Moment :** In atoms, the permanent magnetic moments can arise due to the following :

1. the orbital magnetic moment of the electrons
2. the spin magnetic moment of the electrons
3. the spin magnetic moment of the nucleus.

**Orbital magnetic moment of the electrons:** In an atom, electrons revolve round the nucleus in different circular orbits.

Let  $m$  be the mass of the electron and  $r$  be the radius of the orbit in which it moves with angular velocity  $\omega$ .

The electric current due to the moving electron  $I = -$  ( number of electrons flowing per second  $\times$  charge of an electron )

Therefore  $I = - e \omega / 2 \Pi$  -----(1)

The current flowing through a circular coil produces a magnetic field in a direction perpendicular to the area of coil and it is identical to the magnetic dipole. the magnitude of the magnetic moment produced by such a dipole is

$$\begin{aligned} \mu_m &= I \cdot A \\ &= ( - e \omega / 2 \Pi ) ( \Pi r^2 ) \\ &= - e \omega r^2 / 2 = ( - e / 2 m ) ( m \omega r^2 ) = - ( e / 2 m ) L \text{ -----(2)} \end{aligned}$$

where  $L = m \omega r^2$  is the orbital angular momentum of electron. The minus sign indicates that the magnetic moment is anti – parallel to the angular momentum  $L$ . A substance therefore possesses permanent magnetic dipoles if the electrons of its constituent atom have a net non-vanishing angular momentum. The ratio of the magnetic dipole moment of the electron due to its orbital motion and the angular momentum of the orbital motion is called orbital gyro magnetic ratio, represented by  $\gamma$ .

Therefore  $\gamma = \text{magnetic moment} / \text{angular momentum} = e / 2m$

The angular momentum of an electron is determined by the orbital quantum number 'l' given by  $l = 0, 1, 2, \dots, (n - 1)$  where  $n$  is principal quantum number  $n = 1, 2, 3, 4, \dots$  corresponding to K, L, M, N,.....shells.

The angular momentum of the electrons associated with a particular value of  $l$  is given by  $l ( h / 2 \Pi )$

The strength of the permanent magnetic dipole is given by

$$\mu_{el} = - ( e / 2 m ) ( l h / 2 \Pi )$$

$$\text{i.e } \mu_{el} = - (e h l / 4 \Pi m) = - \mu_B l \text{ -----(3)}$$

The quantity  $\mu_B = e h / 4 \Pi m$  is an atomic unit called Bohr Magnetron and has a value  $9.27 \times 10^{-24}$  ampere metre<sup>2</sup>

In an atom having many electrons, the total orbital magnetic moment is determined by taking the algebraic sum of the magnetic moments of individual electrons. The moment of a completely filled shell is zero. An atom with partially filled shells will have non zero orbital magnetic moment.

**Magnetic Moment Due to Electron Spin :** The magnetic moment associated with spinning of the electron is called spin magnetic moment  $\mu_{es}$ . Magnetic moment due to the rotation of the electronic charge about one of the diameters of the electron is similar to the earth's spinning motion around its north – south axis.

An electronic charge being spread over a spherical volume, the electron spin would cause different charge elements of this sphere to form closed currents, resulting in a net spin magnetic moment. This net magnetic moment would depend upon the structure of the electron and its charge distribution.

$$\mu_{es} = \gamma (e / 2 m) S \text{ -----(1) where } S = h / 4 \Pi \text{ is spin angular momentum}$$

$$\text{therefore } \mu_{es} \approx 9.4 \times 10^{-24} \text{ ampere metre}^2$$

Thus, the magnetic moments due to the spin and the orbital motions of an electron are of the same order of magnitude. The spin and electron spin magnetic moment are intrinsic properties of an electron and exist even for a stationary electron. Since the magnitude of spin magnetic moment is always same, the external field can only influence its direction. If the electron spin moments are free to orient themselves in the direction of the applied field B. In a varying field, it experiences a force in the direction of the increasing magnetic field due to spin magnetic moments of its various electrons.

**Magnetic Moment due to Nuclear Spin :** Another contribution may arise from the nuclear magnetic moment. By analogy with Bohr Magnetron, the nuclear magneton arises due to spin of the nucleus. It is given by

$$\mu_{ps} = e h / 4 \Pi M_p$$

$$\mu_{ps} = 5.05 \times 10^{-27} \text{ ampere metre}^2 \text{ where } M_p \text{ is mass of proton.}$$

The nuclear magnetic moments are smaller than those associated with electrons.

**Classification Of Magnetic Materials :** All matter respond in one way or the other when subjected to the influence of a magnetic field. The response could be strong or weak, but there is none with zero response i.e, there is no matter which is non magnetic in the absolute sense. Depending upon the magnitude and sign of response to the applied field, and also on the basis of effect of temperature on the magnetic properties, all materials are classified broadly under 3 categories.

1. Diamagnetic materials
2. Paramagnetic materials,
3. Ferromagnetic materials

two more classes of materials have structure very close to ferromagnetic materials but possess quite different magnetic effects. They are i. Anti ferromagnetic materials and ii. Ferri magnetic materials

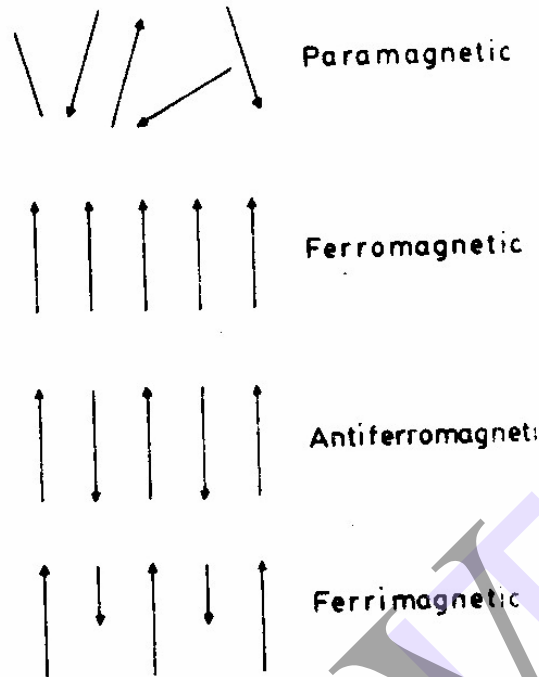

1. **Diamagnetic materials:** Diamagnetic materials are those which experience a repelling force when brought near the pole of a strong magnet. In a non uniform magnetic field they are repelled away from stronger parts of the field.

In the absence of an external magnetic field, the net magnetic dipole moment over each atom or molecule of a diamagnetic material is zero.

Ex: Cu, Bi, Pb, Zn and rare gases.

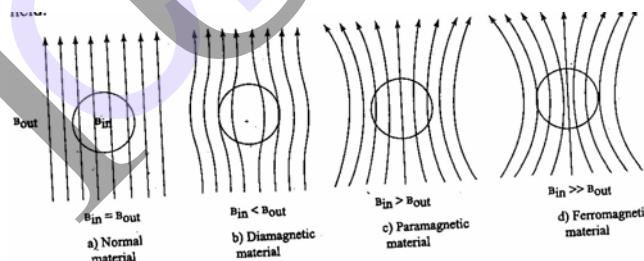

Fig. The behaviour of magnetic materials in the presence of magnetic field.

**Paramagnetic materials:** Paramagnetic materials are those which experience a feeble attractive force when brought near the pole of a magnet. They are attracted towards the stronger parts of magnetic field. Due to the spin and orbital motion of the electrons, the atoms of paramagnetic material possess a net intrinsic permanent moment.

Susceptibility  $\chi$  is positive and small for these materials. The susceptibility is inversely proportional to the temperature  $T$ .

$$\chi \propto 1/T$$

$$\chi = C/T \quad \text{where } C \text{ is Curie's temperature.}$$

Below superconducting transition temperatures, these materials exhibit the Para magnetism.

Examples: Al, Mn, Pt,  $\text{CuCl}_2$ .

**Ferromagnetic Materials:** Ferromagnetic materials are those which experience a very strong attractive force when brought near the pole of a magnet. These materials, apart from getting magnetized parallel to the direction of the applied field, will continue to retain the magnetic property even after the magnetizing field removed. The atoms of ferromagnetic materials also have a net intrinsic magnetic dipole moment which is due to the spin of the electrons.

Susceptibility is always positive and large and it depends upon temperature.

$$\chi = C / (T - \theta) \quad (\text{only in paramagnetic region i.e., } T > \theta)$$

$\theta$  is Curie's temperature.

When the temperature of the material is greater than its Curie temperature then it converts into paramagnetic material.

Examples: Fe, Ni, Co, MnO.

**Antiferromagnetic materials :** These are the ferromagnetic materials in which equal no of opposite spins with same magnitude such that the orientation of neighbouring spins is in antiparallel manner are present.

Susceptibility is small and positive and it is inversely proportional to the temperature.

$$\chi = C / (T + \theta)$$

the temperature at which anti ferromagnetic material converts into paramagnetic material is known as Neel's temperature.

Examples: FeO,  $\text{Cr}_2\text{O}_3$ .

**Ferrimagnetic materials:** These are the ferromagnetic materials in which equal no of opposite spins with different magnitudes such that the orientation of neighbouring spins is in antiparallel manner are present.

Susceptibility positive and large, it is inversely proportional to temperature

$$\chi = C / (T \pm \theta) \quad T > T_N \quad (\text{Neel's temperature})$$

Examples :  $\text{ZnFe}_2\text{O}_4$ ,  $\text{CuFe}_2\text{O}_4$

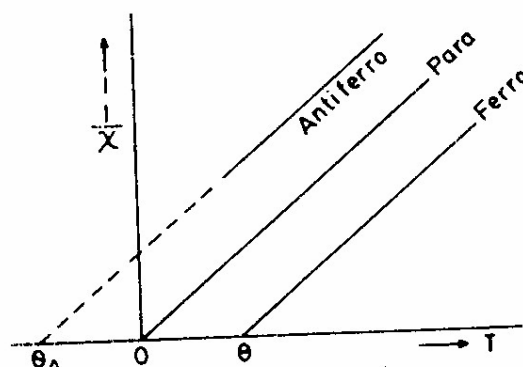

**Domain theory of ferromagnetism:** According to Weiss, a virgin specimen of ferromagnetic material consists of a no of regions or domains ( $\approx 10^{-6}$  m or larger) which are spontaneously magnetized. In each domain spontaneous magnetization is due to parallel alignment of all magnetic dipoles. The direction of spontaneous magnetization varies from domain to domain. The resultant magnetization may hence be zero or nearly zero. When an external field is applied there are two possible ways of alignment fo a random domain.

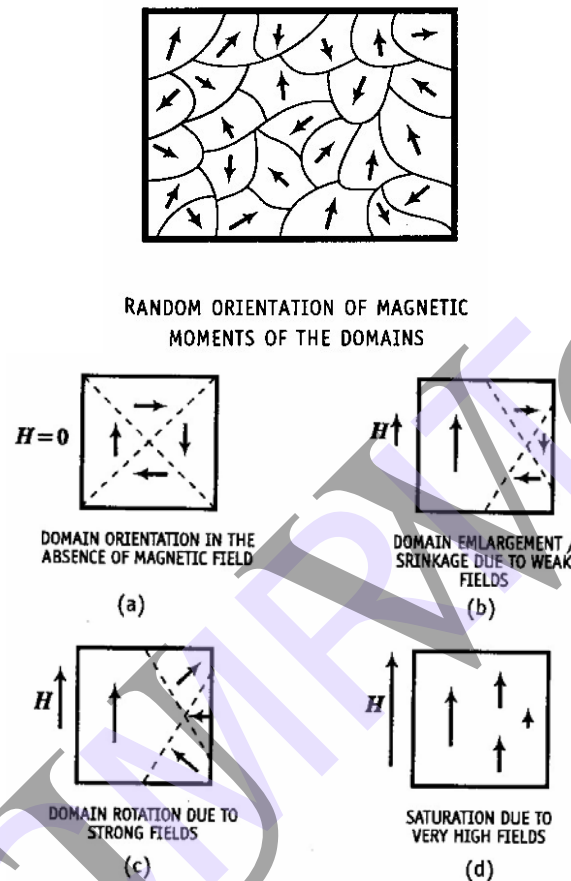

- i). **By motion of domain walls:** The volume of the domains that are favourably oriented with respect to the magnetizing field increases at the cost of those that are unfavourably oriented
- ii) **By rotation of domains:** When the applied magnetic field is strong, rotation of the direction of magnetization occurs in the direction of the field.

**Hysteresis curve (study of B-H curve):** The hysteresis of ferromagnetic materials refers to the lag of magnetization behind the magnetization field. when the temperature of the ferromagnetic substance is less than the ferromagnetic Curie temperature ,the substance exhibits hysteresis. The domain concept is well suited to explain the phenomenon of hysteresis. The increase in the value of the resultant magnetic moment of the specimen by the application of the applied field , it attributes to the 1. motion of the domain walls and 2. rotation of domains.



When a weak magnetic field is applied, the domains that are aligned parallel to the field and in the easy direction of magnetization, grow in size at the expense of less favorably oriented ones. This results in Bloch wall movement and when the weak field is removed, the domains reverse back to their original state. This reverse wall displacement is indicated by OA of the magnetization curve. When the field becomes stronger, the Bloch wall movement continues and it is mostly irreversible movement. This is indicated by the path AB of the graph. The phenomenon of hysteresis is due to this irreversibility.

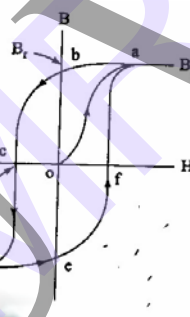
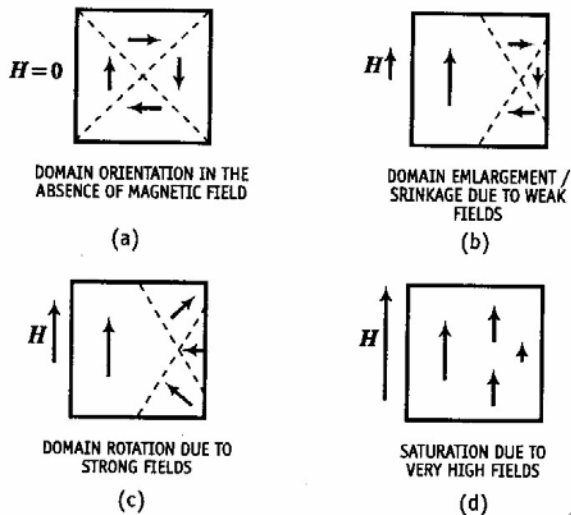

Fig. Schematic representation of the hysteresis loop for a ferromagnetic material.

At the point B all domains have got magnetized along their easy directions. Application of still higher fields rotates the domains into the field direction which may be away from the easy direction. Once the domain rotation is complete the specimen is saturated denoted by C. on removal of the field the specimen tends to attain the original configuration by the movement of Bloch walls. But this movement is hampered by the impurities, lattice imperfections etc, and so more energy must be supplied to overcome the opposing forces. This means that a coercive field is required to reduce the magnetization of the specimen to zero. The amount of energy spent in this regard is a loss. Hysteresis loss is the loss of energy in taking a ferromagnetic body through a complete cycle of magnetization and this loss is represented by the area enclosed by the hysteresis loop.

A hysteresis curve shows the relationship between the magnetic flux density B and applied magnetic field H. It is also referred to as the B-H curve(loop).

### Hard and Soft Magnetic Materials:

Hysteresis loop of the ferromagnetic materials vary in size and shape. This variation in hysteresis loops leads to a broad classification of all the magnetic materials into hard type and soft type.

### Hard Magnetic Materials:

Hard magnetic materials are those which are characterized by large hysteresis loop because of which they retain a considerable amount of their magnetic energy after the external magnetic field is switched off. These materials are subjected to a magnetic field of increasing intensity, the domain walls movements are impeded due to certain factors. The cause for such a nature is attributed to the presence of impurities or non-magnetic materials, or the lattice imperfections. Such defects attract the domain walls thereby reducing the wall energy. It results in a stable state for the domain walls and gives mechanical hardness to the material which increases the electrical resistivity. The increase in electrical resistivity brings down the eddy current loss if used in a.c conditions. The hard magnetic materials can neither be easily magnetized nor easily demagnetized.

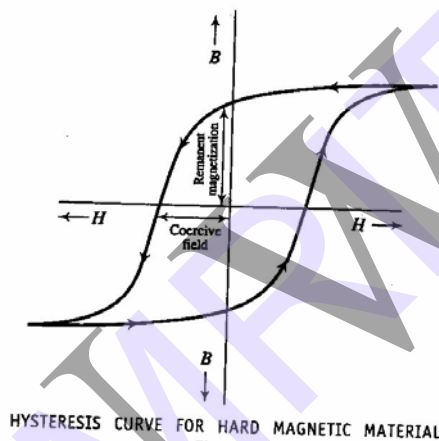

### Properties:

1. High remanent magnetization
2. High coercivity
3. High saturation flux density
4. Low initial permeability
5. High hysteresis energy loss
6. High permeability
7. The eddy current loss is low for ceramic type and large for metallic type.

Examples of hard magnetic materials are, i) Iron- nickel- aluminum alloys with certain amount of cobalt called Alnico alloy. ii) Copper nickel iron alloys. iii) Platinum cobalt alloy.

Applications of hard magnetic materials: For production of permanent magnets, used in magnetic detectors, microphones, flux meters, voltage regulators, damping devices and magnetic separators.

### Soft Magnetic Materials:

Soft magnetic materials are those for which the hysteresis loops enclose very small area. They are the magnetic materials which cannot be permanently magnetized. In these materials, the domain walls motion occurs easily. Consequently, the coercive force assumes a small value and makes the hysteresis loop a narrow one because of which, the hysteresis loss

becomes very small. For the same reasons, the materials can be easily magnetized and demagnetized.

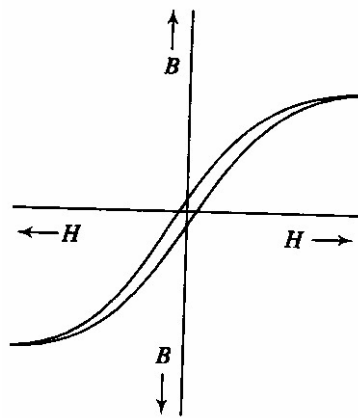

HYSTERESIS CURVE FOR SOFT  
MAGNETIC MATERIAL

**Properties:**

1. Low remanent magnetization
2. Low coercivity
3. Low hysteresis energy loss
4. Low eddy current loss
5. High permeability
6. High susceptibility

Examples of soft magnetic materials are

- i) Permalloys ( alloys of Fe and Ni)
- ii) Si – Fe alloy
- iii) Amorphous ferrous alloys ( alloys of Fe, Si, and B)
- iv) Pure Iron (BCC structure)

Applications of soft magnetic materials: Mainly used in electro- magnetic machinery and transformer cores. They are also used in switching circuits, microwave isolators and matrix storage of computers.

## ***SUPERCONDUCTIVITY***

**Introduction :** Certain metals and alloys exhibit almost zero resistivity( i.e. infinite conductivity ) when they are cooled to sufficiently low temperatures. This phenomenon is called superconductivity. This phenomenon was first observed by H.K. Onnes in 1911. He found that when pure mercury was cooled down to below 4K, the resistivity suddenly dropped to zero. Since then hundreds of superconductors have been discovered and studied. Superconductivity is strictly a low temperature phenomenon. Few new oxides exhibited superconductivity just below 125K itself. This interesting phenomena has many important applications in many emerging fields.

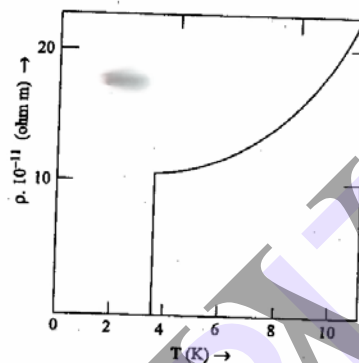

**Fig.** The electrical resistivity  $\rho$  of tin, as a function of temperature near 0K.

**General Properties:** The temperature at which the transition from normal state to superconducting state takes place on cooling in the absence of magnetic field is called the critical temperature ( $T_c$ ) or the transition temperature.

The following are the general properties of the superconductors:

1. The transition temperature is different to different substances.
2. For a chemically pure and structurally perfect specimen, the superconducting transition is very sharp.
3. Superconductivity is found to occur in metallic elements in which the number of valence electrons lies between 2 and 8.
4. Transition metals having odd number of valence electrons are favourable to exhibit superconductivity while metals having even number of valence electrons are unfavourable.
5. Materials having high normal resistivities exhibit superconductivity.
6. Materials for which  $Z\rho > 106$  (where  $Z$  is the no. of valence electrons and  $\rho$  is the resistivity) show superconductivity.
7. Ferromagnetic and antiferromagnetic materials are not superconductors.
8. The current in a superconducting ring persists for a very long time .

**Effect of Magnetic Field:** Superconducting state of metal depends on temperature and strength of the magnetic field in which the metal is placed. Superconducting disappears if the temperature of the specimen is raised above  $T_c$  or a strong enough magnetic field applied. At temperatures below  $T_c$ , in the absence of any magnetic field, the material is in superconducting state. When the strength of the magnetic field applied reaches a critical value  $H_c$  the superconductivity disappears.

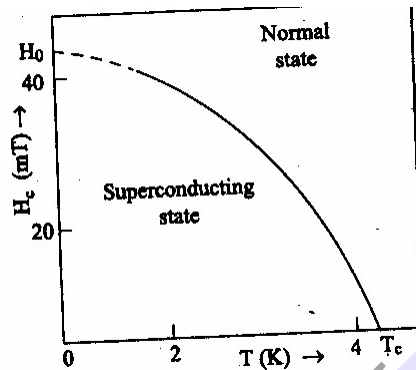

At  $T = T_c$ ,  $H_c = 0$ . At temperatures below  $T_c$ ,  $H_c$  increases. The dependence of the critical field upon the temperature is given by

$$H_c(T) = H_c(0) [1 - (T/T_c)^2] \text{-----(1)}$$

Where  $H_c(0)$  is the critical field at 0K.  $H_c(0)$  and  $T_c$  are constants of the characteristics of the material.

**Meissner effect:** When a weak magnetic field applied to super conducting specimen at a temperature below transition temperature  $T_c$ , the magnetic flux lines are expelled. This specimen acts as on ideal diamagnet. This effect is called meissner effect. This effect is reversible, i.e. when the temperature is raised from below  $T_c$ , at  $T = T_c$  the flux lines suddenly start penetrating and the specimen returns back to the normal state. Under this condition, the magnetic induction inside the specimen is given by

$$B = \mu_0(H + M) \text{-----(2)}$$

Where  $H$  is the external applied magnetic field and  $M$  is the magnetization produced inside the specimen.

When the specimen is super conducting, according to meissner effect inside the bulk semiconductor  $B=0$ .

Hence  $\mu_0(H + M) = 0$

Or  $M = -H \text{-----(3)}$

Thus the material is perfectly diamagnetic.

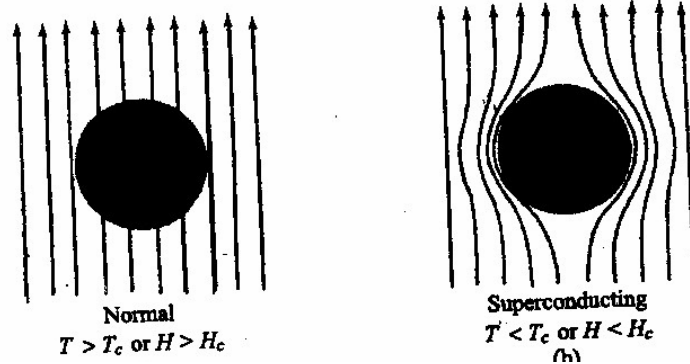

Magnetic susceptibility can be expressed as

$$\chi = M/H = -1 \text{-----(4)}$$

Consider a superconducting material under normal state. Let  $J$  be the current passing through the material of resistivity  $\rho$ . From ohm's law we know that the electric field

$$E = J\rho$$

On cooling the material to its transition temperature,  $\rho$  tends to zero. If  $J$  is held finite.

$E$  must be zero. From Maxwell's eqn, we know

$$\nabla \times E = -dB/dt \text{-----(5)}$$

Under superconducting condition since  $E = 0$ ,  $dB/dt = 0$ , or  $B = \text{constant}$ .

This means that the magnetic flux passing through the specimen should not change on cooling to the transition temperature. The Meissner effect contradicts this result.

According to Meissner effect perfect diamagnetism is an essential property of defining the superconducting state. Thus

From zero resistivity  $E = 0$ ,

From Meissner effect  $B = 0$ .

**Type- I , Type- II superconductors:** Based on diamagnetic response Superconductors are divided into two types, i.e type-I and type-II.

Superconductors exhibiting a complete Meissner effect are called type-1, also called Soft Superconductors. When the magnetic field strength is gradually increased from its initial value  $H < H_C$ , at  $H_C$  the diamagnetism abruptly disappears and the transition from superconducting state to normal state is sharp. Example Zn, Hg, pure specimens of Al and Sn.

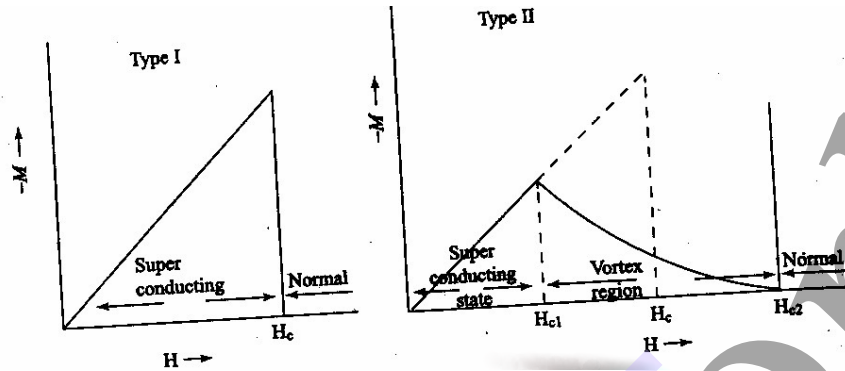

In type-2 Superconductors, transition to the normal state takes place gradually. For fields below  $H_{C1}$ , the material is diamagnetic i.e., the field is completely excluded.  $H_{C1}$  is called the lower critical field. At  $H_{C1}$  the field begins to penetrate the specimen. Penetration increases until  $H_{C2}$  is reached. At  $H_{C2}$ , the magnetization vanishes i.e., the material becomes normal state.  $H_{C2}$  is the upper critical field. Between  $H_{C1}$  and  $H_{C2}$  the state of the material is called the mixed or vortex state. They are also known as hard superconductors. They have high current densities. Example Zr, Nb etc.

**Penetration Depth :** The penetration depth  $\lambda$  can be defined as the depth from the surface at which the magnetic flux density falls to  $1/e$  of its initial value at the surface. Since it decreases exponentially the flux inside the bulk of superconductor is zero and hence is in agreement with the Meissner effect. The penetration depth is found to depend on temperature. its dependence is given by the relation

$$\lambda(T) = \lambda(0) \left(1 - T^4 / T_c^4\right)^{-1/2} \text{ -----(1)}$$

where  $\lambda(0)$  is the penetration depth at  $T = 0K$ .

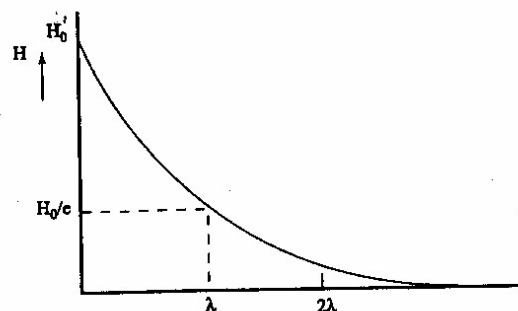

**Fig.** Exponential decrease of the magnetic field inside a superconductor.



According to eqn.(1),  $\lambda$  increases with the increase of  $T$  and at  $T = T_c$ , it becomes infinite. At  $T = T_c$ , the substance changes from superconducting state to normal state and hence the field can penetrate to the whole specimen, i.e., the specimen has an infinite depth of penetration.

**BCS Theory** : BCS theory of superconductivity was put forward by Bardeen, Cooper and Schrieffer in 1957. This theory could explain many observed effects such as zero resistivity, Meissner effect, isotope effect etc. The BCS theory is based on advanced quantum concept.

1. *Electron – electron interaction via lattice deformation*: Consider an electron is passing through the lattice of positive ions. The electron is attracted by the neighbouring positive ion, forming a positive ion core and gets screened by them. The screening greatly reduces the effective charge of this electron. Due to the attraction between the electron and the positive ion core, the lattice gets deformed on local scale. Now if another electron passes by its side of the assembly of the electron and the ion core, it gets attracted towards it. The second electron interacts with the first electron via lattice deformation. The interaction is said to be due to the exchange of a virtual phonon,  $q$ , between the two electrons. The interaction process can be written in terms of wave vector  $k$ , as

$$K_1 - q = K_1' \quad \text{and} \quad K_2 + q = K_2' \quad \text{-----(1)}$$

This gives  $K_1 - K_2 = K_1' + K_2'$ , i.e., the net wave vector of the pair is conserved. The momentum is transferred between the electrons. These two electrons together form a Cooper pair and is known as Cooper electron.

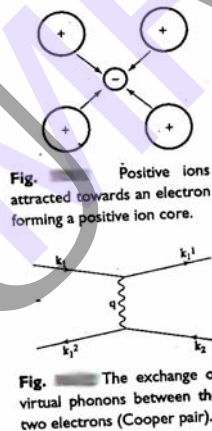

2. *Cooper Pair*: To understand the mechanism of Cooper pair formation, consider the distribution of electrons in metals as given by Fermi – Dirac distribution function.

$$F(E) = 1 / [ \exp(E - E_F / KT) + 1 ]$$

At  $T = 0K$ , all the energy states below Fermi level  $E_F$  are completely filled and all the states above are completely empty.

Let us see what happens when two electrons are added to a metal at absolute zero. Since all the quantum states with energies  $E \leq E_F$  are filled, they are forced to occupy states having energies  $E > E_F$ . Cooper showed that if there is an attraction between the two electrons, they are able to form a bound state so that their total energy is less than  $2 E_F$ .

These electrons are paired to form a single system. These two electrons together form a Cooper pair and is known as Cooper electron. Their motions are correlated. The binding is strongest when the electrons forming the pair have opposite momenta and opposite spins. All electron pairs with attraction among them and lying in the neighbourhood of the Fermi surface form Cooper pairs. These are super electrons responsible for the superconductivity.

In normal metals, the excited states lie just above the Fermi surface. To excite an electron from the Fermi surface even an arbitrarily small excitation energy is sufficient. In superconducting material, when a pair of electrons lying just below the Fermi surface is taken just above it, they form a Cooper pair and their total energy is reduced. This continues until the system can gain no additional energy by pair formation. Thus the total energy of the system is further reduced.

At absolute zero in normal metals there is an abrupt discontinuity in the distribution of electrons across the Fermi surface whereas such discontinuity is not observed in superconductors. As super electrons are always occupied in pairs and their spins are always in opposite directions.

**Isotope Effect :** in superconducting materials, the transition temperature varies with the average isotopic mass,  $M$ , of their constituents. The variation is found to follow the general form

$$T_c \propto M^{-\alpha} \quad \text{----- (1)}$$

$$\text{Or } M^{\alpha} T_c = \text{constant}$$

Where  $\alpha$  is called the isotope effect coefficient.

### Flux Quantization:

Consider a superconductor in the form of a ring. Let it be at temperature above its  $T_c$  because of which it will be in the normal state. When it is subjected to the influence of a magnetic field, the flux lines pass through the body and also exist outside and inside ring also.

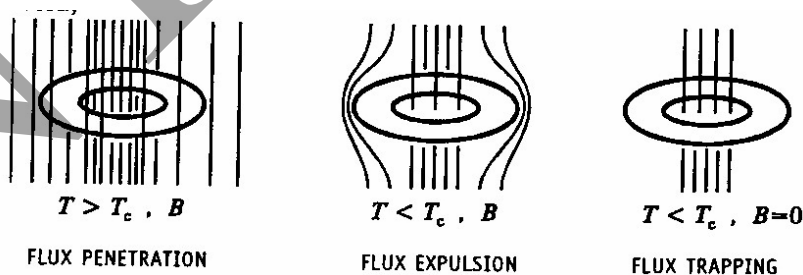

If the body is cooled to a temperature below its  $T_c$ , then as per Meissner effect, the flux lines are expelled from the body i.e. the flux exists both outside the ring and in the hole region but not in the body of the ring. But when the external field is switched off, the magnetic flux lines continue to exist within the hole region, through the rest that surrounded the ring from the exterior would vanish. This is known as flux trapping. It is due to the large currents that are induced as per Faraday's law during the flux decay when the field switched off. Because of the zero resistance property that the superconductor enjoys, these induced currents continue to circulate in the ring practically externally. Thus the flux stand trapped in the loop forever.

It was F.London who gave the idea that the trapped magnetic flux is quantized, as super conductivity is governed by the quantum phenomenon. At first he suggested the quantization of  $\Phi$  as

$$\Phi = nh / e \quad n = 1,2,3,\dots\dots\dots$$

But experiments carried out carefully on very small superconducting hollow cylinders by Deaver and Fairbank , that gave half the values of flux quanta given by London. Thus the governing equation for flux quantization was changed to,

$$\Phi = nh / 2e$$

It happened so because, London's theory was based on supercurrents constituted by electrons as individual entities. This demonstrates conclusively that superconducting current carriers are pairs of electrons and not single ones.

Then the above equation is written as

$$\Phi = n \Phi_0$$

Where  $\Phi_0 = (h/2e)$  is the quantum of flux and is called fluxoid.

**Josephson Effect :** Consider a thin insulating layer sandwiched between two metals. This insulating layer acts as a potential barrier for flow of electrons from one metal to another. Since the barrier is so thin ,mechanically electrons can tunnel through from a metal of higher chemical potential to the other having a lower chemical potential. This continues until the chemical potential of electrons in both the metals become equal.

Consider application of a potential difference across the potential barrier. Now more electrons tunnel through the insulating layer from higher potential side to lower potential side. The current – voltage relation across the tunneling junction obeys the ohm's law at low voltages.

Now consider another case that one of the metals is a superconductor. On applying the potential, it can be observed that no current flows across the junction until the potential reaches a threshold value. It has been found that the threshold potential is nothing but half the energy gap in the superconducting state. Hence the measurement of threshold potential under this condition helps one to calculate the energy gap of superconductor. As the temperature is increased towards  $T_c$  ,more thermally excited electrons are generated. Since they require less energy to tunnel , the threshold voltage decreases. This results in decrease of energy gap itself.

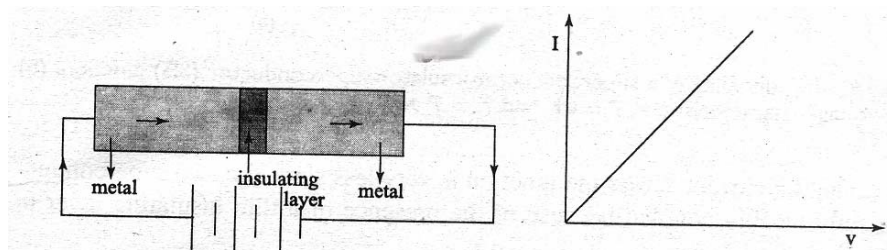

Consider a thin insulating layer sandwiched between two superconductors. In addition to normal tunneling of single electrons, the super electrons also tunnel through the insulating layer from one superconductor to another without dissociation, even at zero potential difference across the junction. Their wave functions on both sides are highly correlated. This is known as Josephson effect.

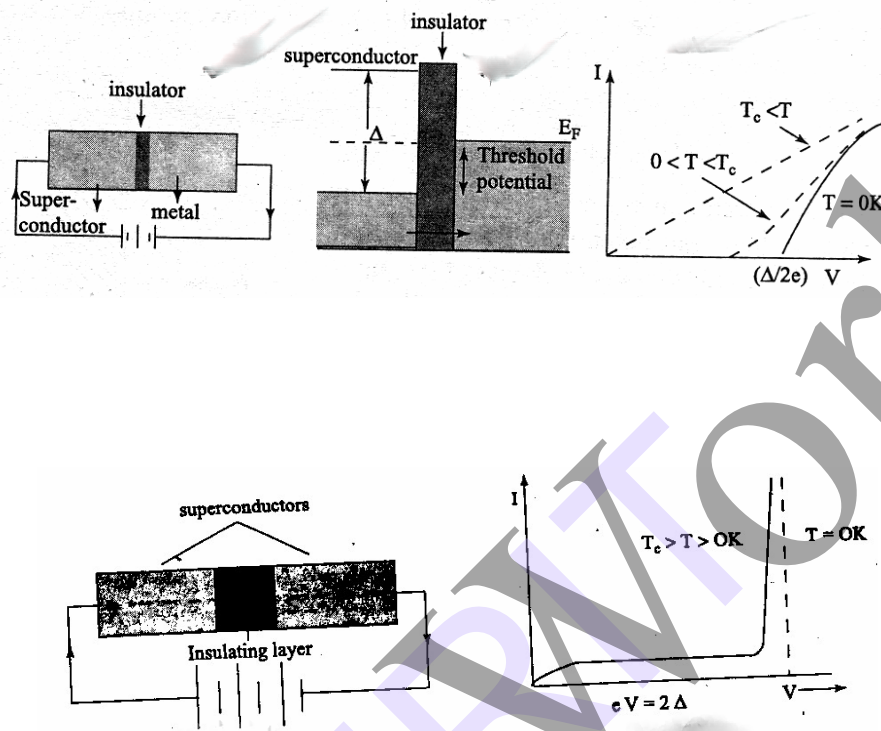

The tunneling current across the junction is very less since the two superconductors are only weakly coupled because of the presence of a thin insulating layer in between.

**D.C. Josephson Effect :** According to Josephson, when tunneling occurs through the insulator it introduces a phase difference  $\Delta\Phi$  between the two parts of the wave function on the opposite sides of the junction.

The tunneling current is given by

$$I = I_0 \sin(\Phi_0) \text{-----(1)}$$

Where  $I_0$  is the maximum current that flows through the junction without any potential difference across the junction.  $I_0$  depends on the thickness of the junction and the temperature.

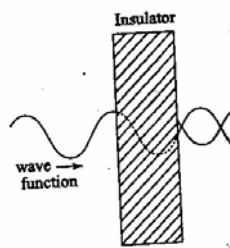

When there is no applied voltage, a d.c. current flows across the junction. The magnitude of the current varies between  $I_0$  and  $-I_0$  according to the value of phase difference  $\Phi_0 = (\Phi_2 - \Phi_1)$ . This is called d.c Josephson effect.

**A.C. Josephson Effect :** let a static potential  $V_0$  is applied across the junction. This results in additional phase difference introduced by cooper pair during tunneling across the junction. This additional phase difference  $\Delta\Phi$  at any time  $t$  can be calculated using quantum mechanics

$$\Delta\Phi = E t / \hbar \text{ -----(1)}$$

Where  $E$  is the total energy of the system.

In the present case  $E = (2 e ) V_0$  . since a cooper pair contains 2 electrons , the factor 2 appears in the above eqn.

Hence  $\Delta\Phi = 2 e V_0 t / \hbar$  .

The tunneling current can be written as

$$I = I_0 \sin ( \Phi_0 + \Delta\Phi ) = I_0 \sin ( \Phi_0 + 2 e V_0 t / \hbar ) \text{ -----(1)}$$

This is of the form

$$I = I_0 \sin ( \Phi_0 + \omega t ) \text{ -----(2)}$$

Where  $\omega = 2 e V_0 / \hbar$  .

This represents an alternating current with angular frequency  $\omega$ . This is the a.c. Josephson effect. when an electron pair crosses the junction a photon of energy  $\hbar\omega = 2eV_0$  is emitted or absorbed.

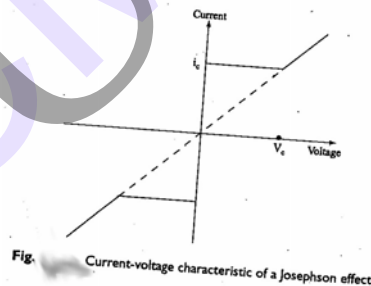

Current – voltage characteristics of a Josephson junction are :

1. When  $V_0 = 0$  , there is a constant flow of d.c current  $i_c$  through the junction. This current is called superconducting current and the effect is the d.c. Josephson effect.
2. So long  $V_0 < V_c$  , a constant d.c.current  $i_c$  flows.
3. When  $V_0 > V_c$  , the junction has a finite resistance and the current oscillates with a frequency  $\omega = 2 e V_0 / \hbar$  . This effect is the a.c Josephson effect.

#### **Applications Of Josephson Effect:**

1. It is used to generate microwaves with frequency  $\omega = 2 e V_0 / \hbar$  .

2. A.C Josephson effect is used to define standard volt.
3. A.C Josephson effect is also used to measure very low temperatures based on the variation of frequency of emitted radiation with temperature.
4. A Josephson junction is used for switching of signals from one circuit to another. The switching time is of the order of 1ps and hence very useful in high speed computers.

#### ***Applications Of Superconductors :***

1. Electric generators : superconducting generators are very smaller in size and weight when compared with conventional generators. The low loss superconducting coil is rotated in an extremely strong magnetic field. Motors with very high powers could be constructed at very low voltage as low as 450V. this is the basis of new generation of energy saving power systems.
2. Low loss transmission lines and transformers : Since the resistance is almost zero at superconducting phase, the power loss during transmission is negligible. Hence electric cables are designed with superconducting wires. If superconductors are used for winding of a transformer, the power losses will be very small.
3. Magnetic Levitation : Diamagnetic property of a superconductor ie , rejection of magnetic flux lines is the basis of magnetic levitation. A superconducting material can be suspended in air against the repulsive force from a permanent magnet. This magnetic levitation effect can be used for high speed transportation.
4. Generation of high Magnetic fields : superconducting materials are used for producing very high magnetic fields of the order of 50Tesla. To generate such a high field, power consumed is only 10kW whereas in conventional method for such a high field power generator consumption is about 3MW. Moreover in conventional method ,cooling of copper solenoid by water circulation is required to avoid burning of coil due to Joule heating.
5. Fast electrical switching :A superconductor possesses two states , the superconducting and normal. The application of a magnetic field greater than  $H_c$  can initiate a change from superconducting to normal and removal of field reverses the process. This principle is applied in development of switching element cryotron. Using such superconducting elements, one can develop extremely fast large scale computers.
6. Logic and storage function in computers : they are used to perform logic and storage functions in computers. The current – voltage characteristics associated with Josephson junction are suitable for memory elements.
7. SQUIDS ( superconducting Quantum Interference Devices ) : It is a double junction quantum interferometer. Two Josephson junctions mounted on a superconducting ring forms this interferometer. The SQUIDS are based on the flux quantization in a superconducting ring. Very minute magnetic signals are detected by these SQUID sensors. These are used to study tiny magnetic signals from the brain and heart. SQUID magnetometers are used to detect the paramagnetic response in the liver. This gives the information of iron held in the liver of the body accurately.



**Questions:**

1. Describe how polarization occurs in a dielectric material.
2. Define dielectric constant of a material.
3. Explain the origin of different kinds of polarization.
4. Describe in brief various types of polarization.
5. Obtain an expression for the internal field.
6. Derive Clausius - Mossotti equation.
7. Describe the frequency dependence of dielectric constant.
8. Write note on Dielectric loss.
9. Explain the properties of ferroelectric materials.
10. What is piezoelectricity?
11. Distinguish between dia, para, ferro, antiferro, and ferromagnetic materials.
12. what is meant by Neel temperature
13. Define magnetization and show that  $B = \mu_0 (H + M)$ .
14. Explain the origin of magnetic moment.
15. Describe the domain theory of ferromagnetism.
16. What is Bohr Magneton.
17. Draw and explain the hysteresis curve.
18. Discuss the characteristic features of soft and hard magnetic materials.
19. What are the applications of soft and hard magnetic materials?



## UNIT – VII

### 12. LASERS

#### Introduction:

It is a device to produce a powerful monochromatic narrow beam of light in which the waves are convergent. Laser is an acronym for light amplification by stimulated emission of radiation.

Maser is an acronym of microwave amplification by stimulated emission of radiation.

The light emitted from the conventional light source (eg: sodium lamp, candle) is said to be incoherent. Because the radiation emitted from different atom do not have any definite phase relationship with each other. Lasers are much important because the light sources having high monochromaticity, high intensity, high directionality and high coherence.

In the laser the principal of maser is employed in the frequency range of  $10^{14}$  to  $10^{15}$  Hz and it is termed as optical maser. Laser principle now a day is extended up to  $\gamma$ -rays hence Gamma ray lasers are called Grazers. The first two successful lasers developed during 1960 were Ruby laser and He-Ne lasers. Some lasers emit light in pulses while others emit as a continuous wave.

#### Characteristics of laser radiation:

The four characteristics of a laser radiation over conventional light sources are

- (1) Laser is highly monochromatic
- (2) Laser is highly directional
- (3) Laser is highly coherent
- (4) The intensity of laser is very high

#### HIGHLY MONOCHROMATIC:

The band width of ordinary light is about  $1000\text{\AA}$ . The band width of laser light is about  $10\text{\AA}$ . The narrow band width of a laser light is called on high monochromacity.

**BAND WIDTH:-** The spread of the wavelength (frequency ) about the wavelength of maximum intensity is band width.

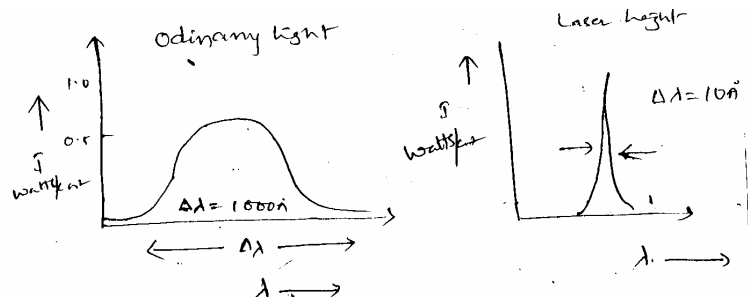

Laser light is more monochromatic than that of a conventional light source. Because of this monochromaticity large energy can be concentrated in to an extremely. Small band width.

For good laser  $\Delta\nu=50\text{Hz}$   $\nu=5\times 10^{14}$  Hz. The degree of non-monochromaticity for a conventional sodium light.

### HIGH DIRECTIONALITY:

The conventional light sources like lamp, torch light, sodium lamp emits light in all directions. This is called divergence. Laser in the other hand emits light only in one direction. This is called directionality of laser light. Light from ordinary light spreads in about few kilometers.

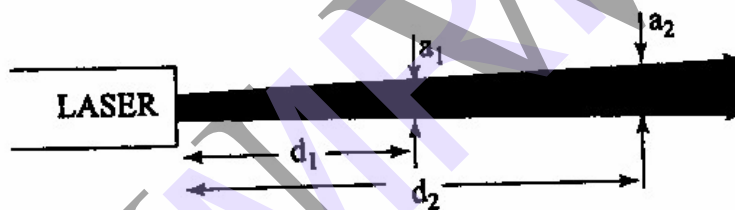

Light from laser spreads to a diameter less than 1 cm for many kilometers.

The directionality of laser beam is given by (or) expressed in divergence.

The divergence  $\Delta\theta = (r_2 - r_1) / d_2 - d_1$

Where  $r_2, r_1$  are the radius of laser beam spots

$d_2, d_1$  are distances respectively from the laser source. Hence for getting a high directionality then should be low divergence.

### HIGHLY COHERENT:

When two light rays are having same phase difference then they are said to be coherent. It is expressed in terms of ordering of light field

Laser has high degree of ordering than other common sources. Due to its coherence only it is possible to create high power ( $10^{12}$  watts) in space with laser beam of  $1\mu\text{m}$  diameter.

There are two independent concepts of coherence.

- 1) Spatial coherence
- (2) Temporal coherence

**SPATIAL COHERENCE:** The two light fields at different point in space maintain a constant phase difference over any time (t) they are said to be spatial coherence.

In He- Ne gas laser the coherence length(  $l_c$  ) is about 600km.It means over the distance the phase difference is maintained over any time .For sodium light it is about 3cm. The coherence & monochromacity is related by

$$\xi = (\Delta\nu / \nu) \propto 1/l_c$$

For the higher coherence length  $\xi$  is small hence it has high monochromacity

**TEMPORAL COHERENCE:** The correlation of phase between the light fields at a point over a period of time. For He- Ne laser it is a about  $10^{-3}$  second , for sodium it is about  $10^{-10}$  second only.

$$\xi = (\Delta\nu / \nu) \propto 1/t_c$$

Higher is the  $t_c$  higher is the monochromacity.

### HIGH INTENSITY:

Intensity of a wave is the energy per unit time flowing through a unit area. The light from an ordinary source spreads out uniformly in all directions and from spherical wave fronts around it.

Ex:- If you look a 100W bulb from a distance of 30cm the power entering the eye is 1 / 1000 of watt.

But in case of a laser light, energy is in small region of space and in a small wavelength and hence is said to be of great intensity.

The power range of laser about  $10^{-3}$ W for gas laser and  $10^9$ W for solid state laser

The number of photons coming out from a laser per second per unit area is given by

$$N_1 = p / h\nu \approx 10^{22} \text{ to } 10^{34} \text{ photons/ m}^2 - \text{sec.}$$

### SPONTANEOUS AND STIMULATED (INDUCED) EMISSION:

Light is emitted or absorbed by particles during their transitions from one energy state to another .the process of transferring a particle from ground state to higher energy state is called excitation. Then the particle is said to be excited.

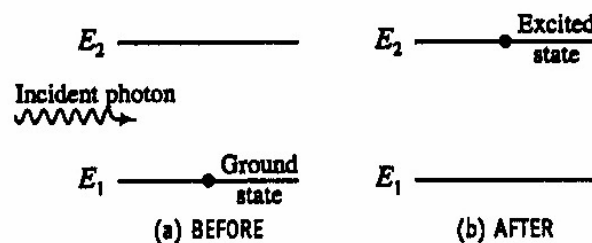

The particle in the excited state can remain for a short interval of time known as life time. The life time is of the order of  $10^{-8}$  sec, in the excited states in which the life time is much greater than  $10^{-8}$  sec are called meta stable states. The life time of the particle in the Meta stable state is of the order  $10^{-3}$  sec

The probability of transition to the ground state with emission of radiation is made up of two factors one is constant and the other variable.

The constant factor of probability is known as spontaneous emission and the variable factor is known as stimulated emission.

**SPONTANEOUS EMISSION:** The emission of particles from higher energy state to lower energy state spontaneously by emitting a photon of energy  $h\nu$  is known as “spontaneous emission”

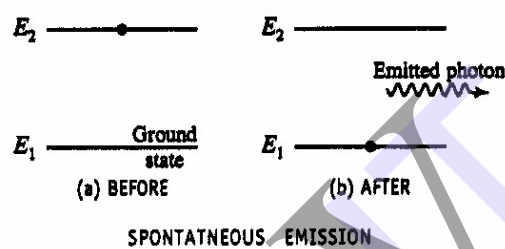

**STIMULATED EMISSION:** The emission of a particle from higher state to lower state by stimulating it with another photon having energy equal to the energy difference between transition energy levels called stimulated emission.

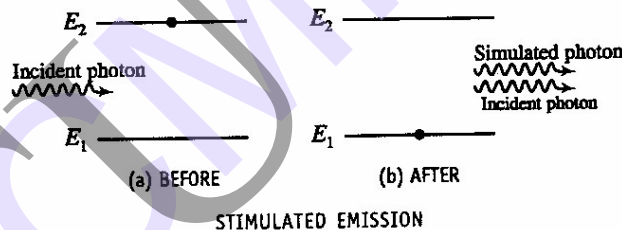

### SPONTANEOUS EMISSION

- 1) Incoherent radiation
- 2) Less Intensity
- 3) Poly chromatic
- 4) One photon released
- 5) Less directionality
- 6) More angular spread during propagation

Ex:-Light from sodium  
Mercury vapour lamp

### STIMULATED EMISSION

- 1) coherent radiation
- 2) high intensity
- 3) mono chromatic
- 4) two photons released
- 5) high directionality
- 6) less angular spread during Propagation

ex: - light from a laser source  
ruby laser, He-He gas laser gas  
Laser

### EINSTEINS EQUATIONS (OR) EINSTEINS CO- EFFICIENTS:

Based on Einstein's theory of radiation one can get the expression for probability for stimulated emission of radiation to the probability for spontaneous emission of radiation under thermal equilibrium.

$E_1, E_2$  be the energy states

$N_1, N_2$  be the no of atoms per unit volume

**ABSORPTION:** If  $\rho(\nu)d\nu$  is the radiation energy per unit volume between the frequency range of  $\nu$  and  $\nu+d\nu$

The number of atoms under going absorption per unit volume per second from level

$$E_1 \text{ to } E_2 = N_1 \rho(\nu) B_{12} \text{-----} \rightarrow 1$$

$B_{12}$  represents probability of absorption per unit time

**STIMILATED EMISSION:** When an atom makes transition  $E_2$  to  $E_1$  in the presence of external photon whose energy equal to  $(E_2 - E_1)$  stimulated emission takes place thus the number of stimulated emission per unit volume per second from levels.

$$E_2 \text{ to } E_1 = N_2 \rho(\nu) B_{21} \text{-----} \rightarrow 2$$

$B_{21}$  is represents probability of stimulated emission per unit time.

**SPONSTANEOUS EMISSION:** An atom in the level  $E_2$  can also make a spontaneous emission by jumping in to lower energy level  $E_1$ .

$$E_2 \text{ to } E_1 = N_2 A_{21} \text{---} \rightarrow 3$$

$A_{21}$  represents probability of spontaneous emission per unit time.

Under steady state

$$(dN / dt) = 0$$

No of atoms under going absorption per second = no of atoms under going emission per second

$$1 = 2 + 3$$

$$N_1 \rho(\nu) B_{12} = N_2 \rho(\nu) B_{21} + N_2 A_{21}$$

$$N_2 A_{21} = N_1 \rho(\nu) B_{12} - N_2 \rho(\nu) B_{21}$$

$$= \rho(\nu) (N_1 B_{12} - N_2 B_{21})$$

$$\rho(\nu) = N_2 A_{21} / (N_1 B_{12} - N_2 B_{21})$$

$$= A_{21} / [(N_1 / N_2) B_{12} - B_{21}] \text{-----} \rightarrow 4$$

From distribution law we know that

$$N_1 / N_2 = e^{(E_2 - E_1) / k_B T}$$

$$= e^{h\nu / k_B T} \text{ -----} \rightarrow 5$$

Substituting  $N_1 / N_2$  in eqn (4) we get

$$\rho(\nu) = A_{21} / B_{21} (e^{h\nu / k_B T} - 1) \text{ -----} \rightarrow 6$$

From Planck's radiation

$$\rho(\nu) = 8\pi h\nu^3 / \lambda^3 \times [1 / (e^{h\nu / k_B T} - 1)] \text{ -----} \rightarrow 7$$

$n$  – refractive index of the medium

$\lambda$  - wave length of the light in air.

$\lambda_m = \lambda / n$  wavelength of light in medium -----  $\rightarrow 8$

$$\rho(\nu) = 8\pi h / \lambda_m^3 \times [1 / (e^{h\nu / k_B T} - 1)] \text{ -----} \rightarrow 9$$

Comparing eqn 6 and 9

$$A_{21} / B_{21} = 8\pi h / \lambda_m^3$$

Where  $A_{21}$ ,  $B_{21}$  are Einstein's co-efficient of spontaneous emission probability per unit time and stimulated emission probability per unit time respectively.

For stimulated emission to be predominant, we have

$$A_{21} / B_{21} \ll 1$$

### **POPULATION INVERSION:**

The no of atoms in higher energy level is less than the no of atoms in lowest energy level. The process of making of higher population in higher energy level than the population in lower energy level is known as population inversion.

Population inversion is achieved by pumping the atoms from the ground level to the higher energy level through optical (or) electrical pumping. It is easily achieved at the metastable state, where the life time of the atoms is higher than that in other higher energy levels.

The states of system, in which the population of higher energy state is more in comparison with the population of lower energy state, are called "Negative temperature state".

A system in which population inversion is achieved is called as an active system. The method of raising the particles from lower energy state to higher energy state is called "Pumping".

### **DIFFERENT TYPES OF LASERS:**

1. Solid state laser - Ruby laser, Nd-YAG laser
2. Gas laser - He-Ne laser, CO<sub>2</sub> laser
3. Semi conductor laser - GaAs laser

## RUBY LASER:

Ruby laser is a three level solid state laser having very high power of hundreds of mega watt in a single pulse it is a pulsed laser.

The system consists of mainly two parts

- 1) **ACTIVE MATERIAL:** Ruby crystal in the form of rod.
- 2) **RESONANT CAVITY:** A fully reflecting plate at the left end of the ruby crystal and partially reflecting end at the right side of the ruby crystal both the surfaces are optically flat and exactly parallel to each other.
- 3) **EXCITING SYSTEM:** A helical xenon flash tube with power supply source.

**CONSTRUCTION:** In ruby laser, ruby rod is a mixture of  $\text{Al}_2\text{O}_3 + \text{Cr}_2\text{O}_3$ . It is a mixture of Aluminum oxide in which some of ions  $\text{Al}^{+3}$  ions concentration doping of  $\text{Cr}^{+3}$  is about 0.05% , then the colour of rod becomes pink. The active medium in ruby rod is  $\text{Cr}^{+3}$  ions. The length of the ruby rod is 4cm and diameter 5mm and both the ends of the ruby rod are silvered such that one end is fully reflecting and the other end is partially reflecting. The ruby rod is surrounded by helical xenon flash lamp tube which provides the optical pumping to raise  $\text{Cr}^{+3}$  ions to upper energy level.

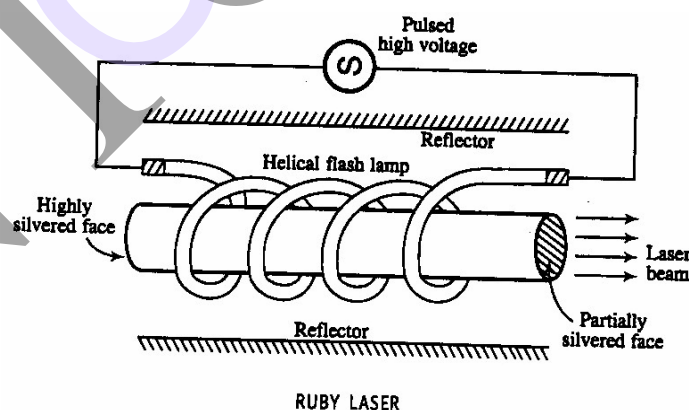

The chromium atom has been excited to an upper energy level by absorbing photons of wave length  $5600\text{\AA}$  from the flash lamp. Initially the chromium ions ( $\text{Cr}^{+3}$ ) are excited to the energy levels  $E_1$  to  $E_3$  , the population in  $E_3$  increases. Since the life time of  $E_3$  level is very less ( $10^{-8}\text{Sec}$ ). The  $\text{Cr}^{+3}$  ions drop to the level  $E_2$  which is metastable of life time  $10^{-3}\text{Sec}$ . The transition from  $E_3$  to  $E_2$  is non-radiative.



Since the life time of metastable state is much longer, the no of ions in this state goes on increasing hence population inversion achieved between the excited metastable state  $E_2$  and the ground state  $E_1$ .

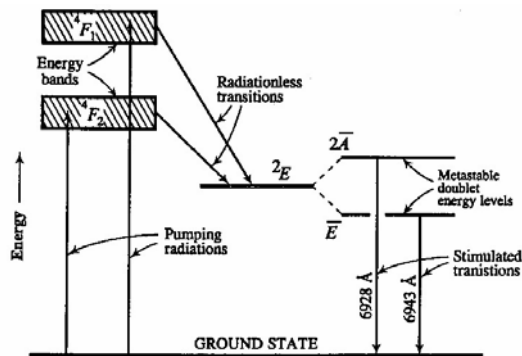

ENERGY LEVEL DIAGRAM OF  $Cr^{3+}$  IN A RUBY CRYSTAL

When an excited ion passes spontaneously from the metastable state  $E_2$  to the ground state  $E_1$ . It emit a photon of wave length  $6993\text{\AA}$ . This photon travel through the ruby rod and if it is moving parallel to the axis of the crystal and it is reflected back and forth by the silver ends until it stimulates an excited ion in  $E_2$ . The emitted photon and stimulated photon are in phase the process is repeated again and again finally the photon beam becomes intense; it emerges out through partially silvered ends.

Since the emitted photon and stimulating photon in phase, and have same frequency and are traveling in the same direction, the laser beam has directionality along with spatial and temporal coherence.

**IMPORTANCE OF RESONATOR CAVITY:** To make the beams parallel to each other curved mirrors are used in the resonator cavity. Resonator mirrors are coated with multi layer dielectric materials to reduce the absorption loss in the mirrors. Resonators act as frequency selectors and also give rise to directionality to the out put beam. The resonator mirror provides partial feedback to the photons.

## He- Ne Laser

### CONSTRUCTION:

He - Ne gas laser consists of a gas discharge tube of length 80cm and diameter of 1cm. The tube is made up of quartz and is filled with a mixture of Neon under a pressure of 0.1mm of Hg. The Helium under the pressure of 1mm of Hg the ratio of He-Ne mixture of about 10:1, hence the no of helium atoms are greater than neon atoms. The mixtures is enclosed between a set of parallel mirrors forming a resonating

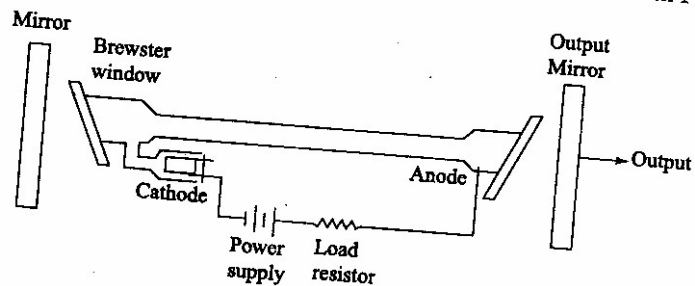

cavity, one of the mirrors is completely reflecting and the other partially reflecting in order to amplify the output laser beam.

### WORKING:

When a discharge is passed through the gaseous mixture electrons are accelerated down the tube these accelerated electrons collide with the helium atoms and excite them to higher energy levels since the levels are meta stable energy levels he atoms spend sufficiently long time and collide with neon atoms in the ground level  $E_1$ . Then neon atoms are excited to the higher energy levels  $E_4$  &  $E_6$  and helium atoms are de excited to the ground state  $E_1$

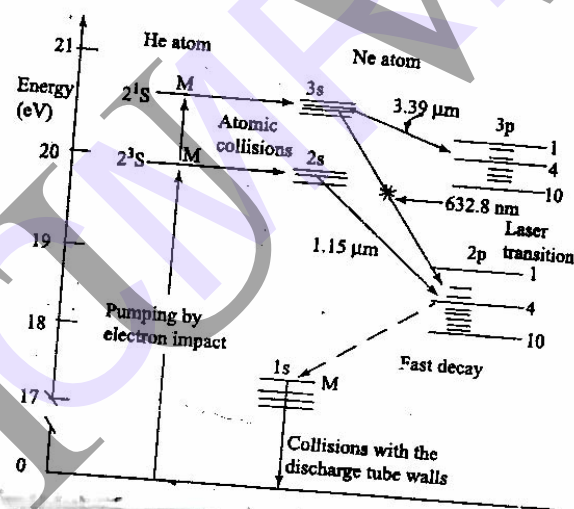

Since  $E_6$  &  $E_4$  are meta stable states, population inversion takes place at there levels. The stimulated emission takes place between  $E_6$  to  $E_3$  gives a laser light of wave length  $6328\text{\AA}$  and the stimulated emission between  $E_6$  and  $E_5$  gives a laser light wave length of  $3.39\mu\text{m}$ . Another stimulated emission between  $E_4$  to  $E_3$  gives a laser light wave length of  $1.15\mu\text{m}$ . The neon atoms undergo spontaneous emission from  $E_3$  to  $E_2$  and  $E_5$  to  $E_2$ . Finally the neon atoms are returned to the ground state  $E_1$  from  $E_2$  by non-radeative diffusion and collision process.

After arriving the ground state, once again the neon atoms are raised to  $E_6$  &  $E_4$  by excited helium atoms thus we can get continuous out put from He-Ne laser.

But some optical elements placed inside the laser system are used to absorb the infrared laser wave lengths  $3.39\mu\text{m}$  and  $1.15\mu\text{m}$ . Hence the output of He-Ne laser contains only a single wave length of  $6328\text{\AA}$  and the output power is about few milliwatts .

## CO<sub>2</sub> LASER

### Construction and working:

We know that a molecule is made up of two or more atoms bound together. In molecule in addition to electronic motion, the constituent atoms in a molecule can vibrate in relation to each other and the molecule as a whole can rotate. Thus the molecule is not only characterized by electronic levels but also by vibration and rotational levels. The fundamental modes of vibrations of CO<sub>2</sub> molecule shown in Fig.

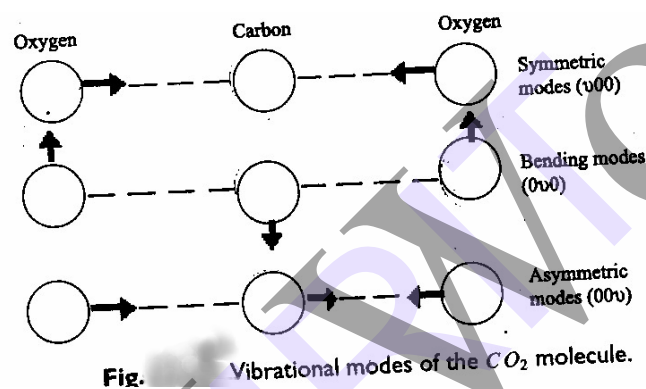

CO<sub>2</sub> Laser is a gas discharge, which is air cooled. The filling gas within the discharge tube consists primarily of, CO<sub>2</sub> gas with 10 – 20%, Nitrogen around 10 – 20 % H<sub>2</sub> or Xenon ( Xe ) a few percent usually only in a sealed tube.

The specific proportions may vary according to the particular application. The population inversion in the laser is achieved by following sequence:

1. Electron impact excites vibration motion of the N<sub>2</sub>. Because N<sub>2</sub> is a homo nuclear molecule, it cannot lose this energy by photon emission and it is excited vibration levels are therefore metastable and live for long time.
2. Collision energy transfer between the N<sub>2</sub> and the CO<sub>2</sub> molecule causes vibration excitation of the CO<sub>2</sub>, with sufficient efficiency to lead to the desired population inversion necessary for laser operation.

Because CO<sub>2</sub> lasers operate in the infrared, special materials are necessary for their construction. Typically the mirrors are made of coated silicon, molybdenum or gold, while windows and lenses are made of either germanium or zinc selenide. For high power application gold mirrors and zinc selenide windows and lenses are preferred. Usually lenses and windows are made out of salt (NaCl or KCl). While the material is inexpensive, the lenses windows degraded slowly with exposure to atmosphere moisture.

The most basic form of a CO<sub>2</sub> laser consist of a gas discharge ( with a mix close to that specified above) with a total reflector at one end and an output coupler ( usually a semi reflective coated zinc selenide mirror ) at the output end. The reflectivity of the out put

coupler is typically around 5 – 15 %. The laser output may be edge coupled in higher power systems to reduce optical heating problems.

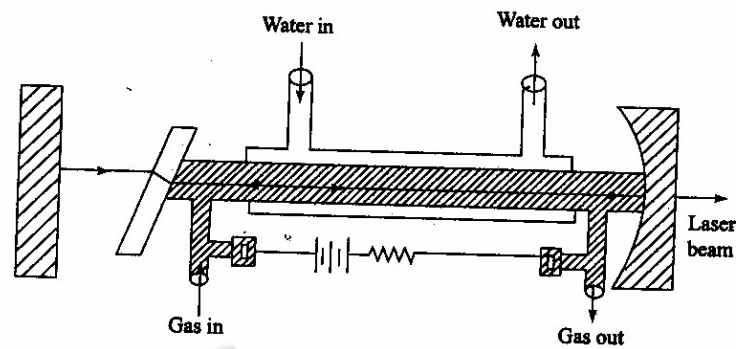

CO<sub>2</sub> lasers output power is very high compared to Ruby laser or He – Ne lasers. All CO<sub>2</sub> lasers are rated in Watts or kilowatts where the output power of Ruby laser or He – Ne laser is rated in mill watts. The CO<sub>2</sub> laser can be constructed to have CW powers between mill watts and hundreds of kilowatts.

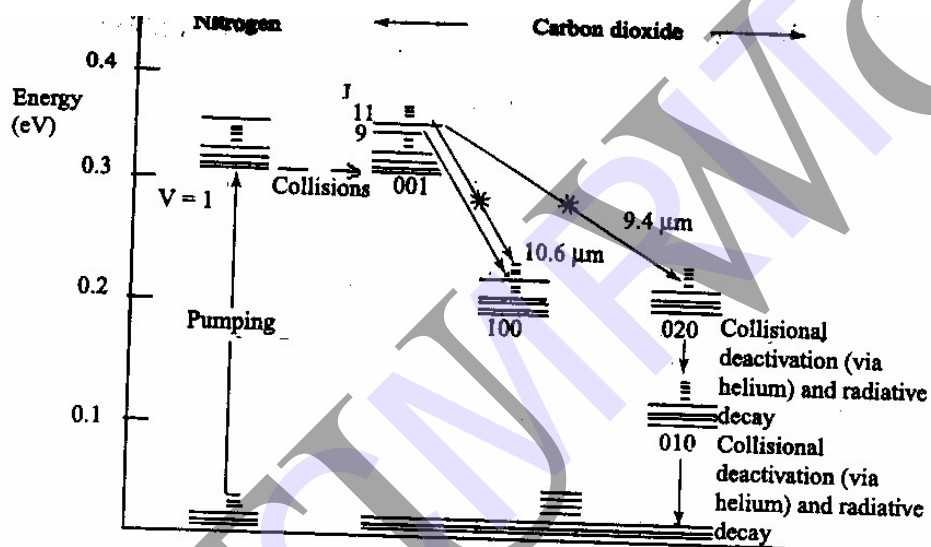

### SEMICONDUCTOR LASER (Gallium Arsenide Diode Laser or Homo Junction Laser):

Semiconductor laser is also known as diode laser

#### PRINCIPLE:

In the case direct band gap semiconductors there is a large possibility for direct recombination of hole and electron emitting a photon. GaAs is a direct band gap semiconductor and hence it is used to make lasers and light emitting diodes. The wave lengths of the emitted light depend on the band gap of the material.

**CONSTRUCTIONS:** The P-region and N-region in the diode are obtained by heavily doping germanium and tellurium respectively in GaAs. The thickness of the P-N junction layer is very narrow at the junction, the sides are well polished and parallel to each other. Since the refractive index of GaAs is high the reflectance at the material air interface is sufficiently large so that the external mirrors are not necessary to produce multiple

reflections. The P-N junction is forward biased by connection positive terminal to P-type and negative terminal to N type.

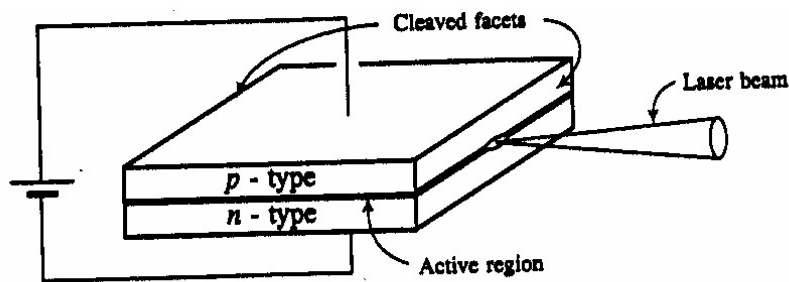

SEMICONDUCTOR LASER

**WORKING:** When the junction is forward biased a large current of order  $10^4$  amp/cm<sup>2</sup> is passed through the narrow junction to provide excitation. Thus the electrons and holes injected from N side and P side respectively. The continuous injection of charge carries the population inversion of minority carriers in N and P sides respectively.

The excess minority electrons in the conduction band of P – layers recombine with the majority holes in the valence band of P-layer emitting light photons similarly the excess minority holes in the valence band of N- layers recombine with the majority electrons in the conduction band of N- layer emitting light photons.

The emitted photons increase the rate of recombination of injected electrons from the N- region and holes in P- region. Thus more no of photons are produced hence the stimulated emission take place, light is amplified.

The wave length of emitted radiation depends upon the concentration of donor and acceptor atoms in GaAs the efficiency of laser emission increases, when we cool the GaAs diode.

**DRAWBACKS:-**

1. Only pulsed laser output is obtained
2. Laser output has large divergence
3. Poor coherence

**APPLICATION OF LASERS:**

**Lasers in scientific research**

- 1) Lasers are used to clean delicate pieces of art, develop hidden finger prints
- 2) Laser are used in the fields of 3D photography called holography
- 3) Using lasers the internal structure of micro organisms and cells are studied very accurately
- 4) Lasers are used to produce certain chemical reactions.

**Laser in Medicine:**

- 1) The heating action of a laser bean used to remove diseased body tissue
- 2) Lasers are used for elimination of moles and tumours, which are developing in the skin tissue.

- 3) Argon and CO<sub>2</sub> lasers are used in the treatment liver and lungs
- 4) Laser beam is used to correct the retinal detachment by eye specialist

**Lasers in Communication:**

- 1) More amount of data can be sent due to the large band width of semiconductor lasers
- 2) More channels can be simultaneously transmitted
- 3) Signals cannot be tapped
- 4) Atmospheric pollutants concentration, ozone concentration and water vapour concentration can be measured

**Lasers in Industry:** Lasers are used

- 1) To blast holes in diamonds and hard steel
- 2) To cut, drill, weld and remove metal from surfaces
- 3) To measure distance to making maps by surveyors
- 4) For cutting and drilling of metals and non metals such as ceramics, plastics, glass

**Questions:**

1. Explain the terms i) Absorption, ii) spontaneous emission, iii) Stimulated emission, iv) pumping mechanism, v) Population inversion, vi) Optical cavity
2. What is population inversion? How is it achieved?
3. Explain the characteristics of a laser beam.
4. Distinguish between spontaneous and stimulated emission.
5. Derive the Einstein's coefficients.
6. With neat diagrams, describe the construction and action of a ruby laser.
7. Explain the working of He – Ne laser
8. Describe the CO<sub>2</sub> laser
9. Explain the semiconductor laser.
10. Mention some applications of laser in different fields.

## 13. FIBER OPTICS

**Introduction:** In 1870 John Tyndall demonstrated that light follows the curve of a stream of water pouring from a container; it was this simple principle that led to the study and development of application of the fiber optics. The transmission of information over fibers has much lower losses than compared to that of cables. The optical fibers are most commonly used in telecommunication, medicine, military, automotive and in the area of industry. In fibers, the information is transmitted in the form of light from one end of the fiber to the other end with min.losses.

### Advantages of optical fibers:

- Higher information carrying capacity.
- Light in weight and small in size.
- No possibility of internal noise and cross talk generation.
- No hazards of short circuits as in case of metals.
- Can be used safely in explosive environment.
- Low cost of cable per unit length compared to copper or G.I cables.
- No need of additional equipment to protect against grounding and voltage problems.
- Nominal installation cost.
- Using a pair of copper wires only 48 independent speech signals can be sent simultaneously whereas using an optical fiber 15000 independent speeches can be sent simultaneously.

### Basic principle of Optical fiber:

The mechanism of light propagation along fibers can be understood using the principle of geometrical optics. The transmission of light in optical fiber is based on the phenomenon of total internal reflection.

Let  $n_1$  and  $n_2$  be the refractive indices of core and cladding respectively such that  $n_1 > n_2$ . Let a light ray traveling from the medium of refractive index  $n_1$  to the refractive index  $n_2$  be incident with an angle of incidence "i" and the angle of refraction "r". By Snell's law

$$n_1 \sin i = n_2 \sin r \dots \dots \dots (1)$$

The refractive ray bends towards the normal as the ray travels from rarer medium to denser medium. On the other hand, the refracted ray bends away from normal as it travel from denser medium to rarer medium. In the later case, there is a possibility to occur total internal reflection provided, the angle of incidence is greater than critical angle( $\theta_c$ ). This can be understood as follows.



1. When  $i < \theta_c$ , then the ray refracted is into the second medium as shown in below fig1.
2. When  $i = \theta_c$ , then the ray travels along the interface of two media as shown in fig2.
3. When  $i > \theta_c$  then the ray totally reflects back into the same medium as shown in fig3.

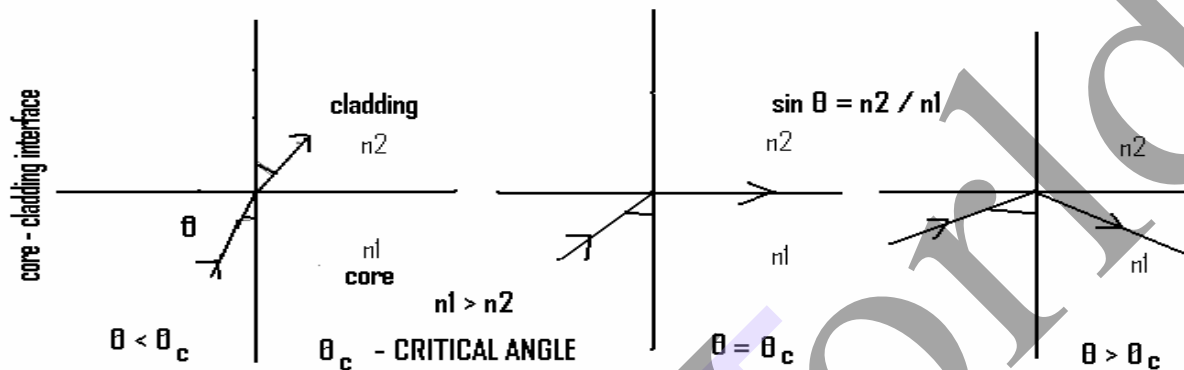

Suppose if  $i = \theta_c$  then  $r = 90^\circ$ , hence

$$n_1 \sin \theta_c = n_2 \sin 90^\circ$$

$$\sin \theta_c = n_2 / n_1 \quad (\text{since } \sin 90^\circ = 1)$$

$$\theta_c = \sin^{-1}(n_2 / n_1) \dots \dots \dots (2)$$

thus any ray whose angle of incidence is greater than the critical angle, total internal reflection occurs, when a ray is traveling from a medium of high refractive index to low refractive index.

### Construction of optical fiber:

The optical fiber mainly consists of the following parts.

- i. Core
- ii. Cladding
- iii. Silicon coating
- iv. Buffer jacket
- v. Strength material
- vi. Outer jacket

- A typical glass fiber consists of a central core of thickness  $50\mu\text{m}$  surrounded by cladding.
  - Cladding is made up of glass of slightly lower refractive index than core's refractive index, whose over all diameter is  $125\mu\text{m}$  to  $200\mu\text{m}$ .
- Of course both core and cladding are made of same glass and to put refractive index of cladding lower than the refractive index of core, some impurities like Boron, Phosphorous or Germanium are doped.
- Silicon coating is provided between buffer jacket and cladding in order to improve the quality of transmission of light.
  - Buffer jacket over the optical fiber is made of plastic and it protects the fiber from moisture and abrasion.
  - In order to provide necessary toughness and tensile strength, a layer of strength material is arranged surrounding the buffer jacket.

- Finally the fiber cable is covered by black polyurethane outer jacket. Because of this arrangement fiber cable will not be damaged during hard pulling ,bending ,stretching or rolling, though the fiber is of brittle glass.

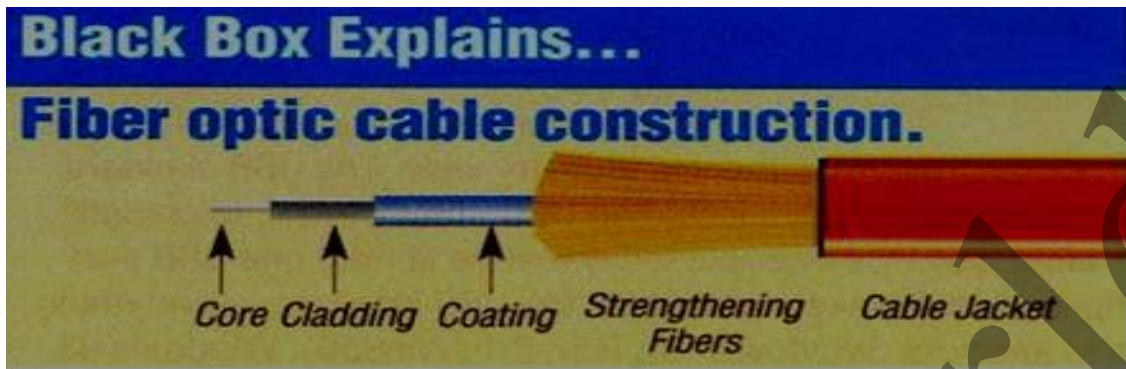

**Acceptance angle and Numerical aperture of optical fiber:**

When the light beam is launched into a fiber, the entire light may not pass through the core and propagate. Only the rays which make the angle of incidence greater than critical angle at the core –cladding interface undergoes total internal reflection. The other rays are refracted to the cladding and is lost. Hence the angle we have to launch the beam at its end is essential to enable the entire light to pass through the core .This maximum angle of launch is called acceptance angle.

Consider an optical fiber of cross sectional view as shown in figure no,  $n_1$  and  $n_2$  are refractive indices of air ,core and cladding respectively such that  $n_1 > n_2 > n_0$ .let light ray is incidenting on interface of air and core medium with an angle of incidence  $\alpha$  .This particular ray enters the core at the axis point A and proceeds after refraction at an angle  $\alpha_r$  from the axis .It then undergoes total internal reflection at B on core at an internal incidence angle  $\theta$ .

To find  $\alpha$  at A:-

In triangle ABC,  $\alpha_r = 90 - \theta$  ..... (1)

From snell' s law ,

$$n_0 \sin \alpha = n_1 \sin \alpha_r \dots\dots\dots(2)$$

$$\sin \alpha = n_1/n_0 \sin \alpha_r \dots\dots\dots(3)$$

From equations 1, 3

$$\sin \alpha = n_1/n_0 \sin(90 - \theta ) => \sin \alpha = n_1/n_0 \cos \theta \dots\dots\dots(4)$$

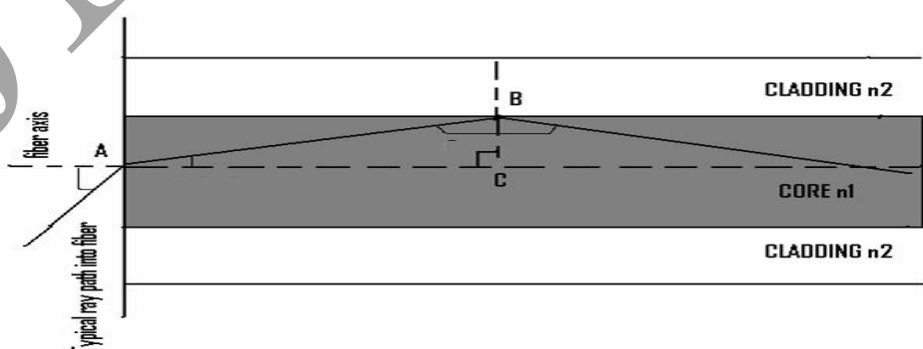

If  $\theta < \theta_c$ , the ray will be lost by refraction. Therefore limiting value for the beam to be inside the core, by total internal reflection is  $\theta_c$ . Let  $\alpha$  (max) be the maximum possible angle of incident at the fiber end face at A for which  $\theta = \theta_c$ . If for a ray  $\alpha$  exceeds  $\alpha$  (max), then  $\theta < \theta_c$  and hence at B the ray will be refracted.

Hence equation 4 can be written as

$$\sin \alpha(\max) = n_1/n_0 \cos \theta_c \dots \dots \dots (5)$$

We know that

$$\begin{aligned} \cos \theta_c &= \sqrt{1 - \sin^2 \theta_c} = \sqrt{1 - n_2^2/n_1^2} \\ &= \sqrt{(n_1^2 - n_2^2)/n_1^2} \dots \dots \dots (6) \end{aligned}$$

Therefore

$$\sin \alpha(\max) = \sqrt{(n_1^2 - n_2^2)/n_0^2}$$

$$\alpha(\max) = \sin^{-1} \sqrt{(n_1^2 - n_2^2)/n_0^2}$$

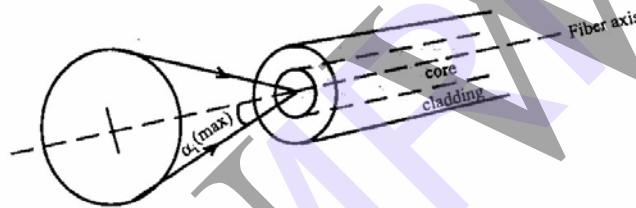

Acceptance cone obtained by rotating the acceptance angle about the fiber axis

This maximum angle is called acceptance angle or acceptance cone angle. Rotating the acceptance angle about the fiber axis gives the acceptance cone of the fiber. Light launched at the fiber end within this acceptance cone alone will be accepted and propagated to the other end of the fiber by total internal reflection. Larger acceptance angles make launching easier.

**Numerical aperture:-**

Light collecting capacity of the fiber is expressed in terms of acceptance angle using numerical aperture. Sine of the maximum acceptance angle is called the numerical aperture of the fiber.

$$\text{Numerical aperture} = \text{NA} = \sin \alpha(\max) = \sqrt{(n_1^2 - n_2^2)/n_0^2} \dots \dots \dots (7)$$

$$\text{Let } \Delta = (n_1^2 - n_2^2)/2n_1^2 \dots \dots \dots (8)$$

For most fiber  $n_1 \approx n_2$

$$\text{Hence } \Delta = (n_1 + n_2)(n_1 - n_2)/2n_1^2 = 2n_1(n_1 - n_2)/2n_1^2$$

$$\Delta = (n_1 - n_2)/n_1 \text{ (fractional difference in refractive indices)} \dots \dots \dots (9)$$

From equation (8)  $n_1^2 - n_2^2 = \Delta 2n_1^2$

Taking under root on both sides

Hence  $=\sqrt{(n_1^2 - n_2^2)} = \sqrt{2 \Delta} n_1$

Substituting this in equation (7) we get

$$NA \approx \sqrt{2 \Delta} n_1/n_0 \dots\dots\dots(10)$$

For air  $n_0 = 1$ , then the above equation can be changed as

$$NA \approx \sqrt{2 \Delta} n_1$$

Numerical aperture of the fiber is dependent only on refractive indices of the core and cladding materials and is not a function of fiber dimensions.

### Types or classification of optical fibers:

Optical fibers are classified as follows:

Depending upon the refractive index profile of the core, optical fibers are classified into two categories

Step index                      Graded index

Depending upon the number of modes of propagation, optical fibers are classified into two categories, they are

Single mode                      Multi mode

Based on the nature of the material used, optical fibers are classified into four categories.

- Glass fiber
- Plastic fiber
  - Glass Core with plastic cladding
  - PCS Fibers(Polymer-Clad Silica fiber)

### Step index fibers:-

In step index fibers the refractive index of the core is uniform through out the medium and undergoes an abrupt change at the interface of core and cladding. The diameter of the core is about 50-200 $\mu\text{m}$  and in case of multi mode fiber. And 10  $\mu\text{m}$  in the case of single mode fiber. The transmitted optical signals travel through core medium in the form of meridional rays, which will cross the fiber axis during every reflection at the core-cladding interface. The shape of the propagation appears in a zig-zac manner.

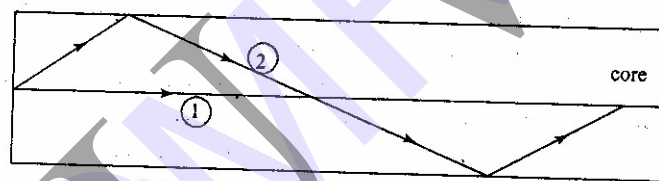
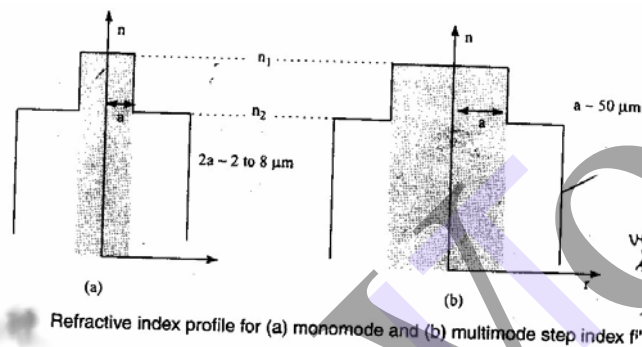
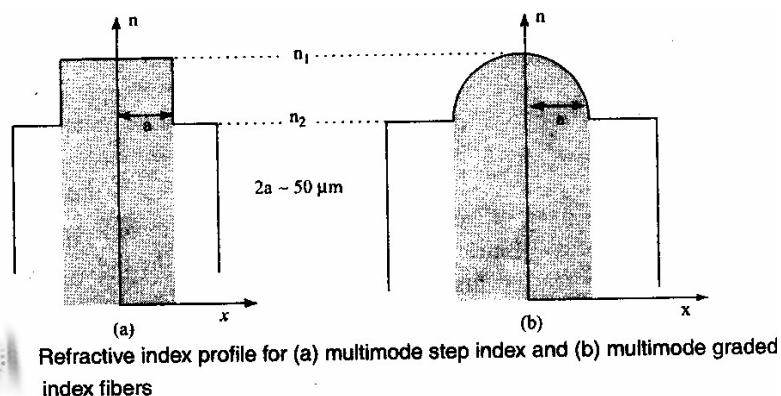
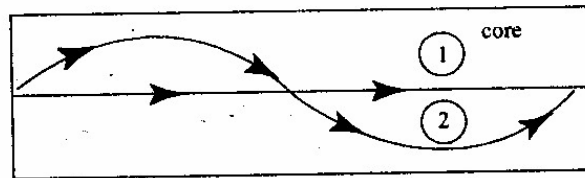

Fig. Signal transmission in step index fiber

### Graded index fiber:-

In these fibers the refractive index of the core varies radially. As the radius increases in the core medium the refractive index decreases. The diameter of the core is about 50 $\mu\text{m}$ . The transmitted optical signals travel through core medium in the form of helical rays, which will not cross the fiber axis at any time.





i) Propagation of different mode rays inside graded index fiber

## Attenuations in optical fiber (or losses):

While transmitting the signals through optical fiber some energy is lost due to few reasons. The major losses in fibers are 1. Distortion losses 2. Transmission losses 3. Bending losses.

### 1. Distortion losses:-

When a pulse is launched at one end of the fiber and collected at the other end of the fiber, the shape and size of the pulse should not be changed. Distortion of signals in optical fiber is an undesired feature. If the output pulse is not same as the input pulse, then it is said that the pulse is distorted. If the refractive index of the core is not uniform most of the rays will travel through the medium of lower refractive index region. Due to this the rays which are travel in fiber will become broadened. Because of this the output pulses will no longer matches with the input pulses.

The distortion takes place due to the presence of imperfections, impurities and doping concentrations in fiber crystals. Dispersion is large in multi mode than in single mode fiber.

### 2. Transmission losses (attenuation):-

The attenuation or transmission losses may be classified into two categories i) Absorption losses ii) scattering losses

#### i) Absorption losses:-

Absorption is a characteristic possessed by all materials every material in universe absorb suitable wavelengths as they incident or passed through the material. In the same way core material of the fiber absorbs wavelengths as the optical pulses or wavelengths pass through it.

#### ii) Scattering losses:-

The core medium of the fiber is made of glass or silica. In the passage of optical signals in the core medium if crystal defects are encountered, they deviate from the path and total internal reflection is discontinued, hence such signals will be destroyed by entering into the cladding however attenuation is minimum in optical fibers compared to other cables.

#### ii) Bending losses:-

The distortion of the fiber from the ideal straight line configuration may also result in fiber loss. Let us consider a wave front that travels perpendicular to the direction of propagation. In order to maintain this, the part of the mode which is on the outside of the bend has to travel faster than that on the inside. As per the theory each mode extends an infinite distance into the cladding though the intensity falls exponentially. Since the refractive index of cladding is less than that of the core ( $n_1 > n_2$ ), the part of the mode traveling in the cladding will attempt to travel faster. As per Einstein's theory of relativity since the part of the mode cannot travel faster the energy associated with this particular part of the mode is lost by radiation.

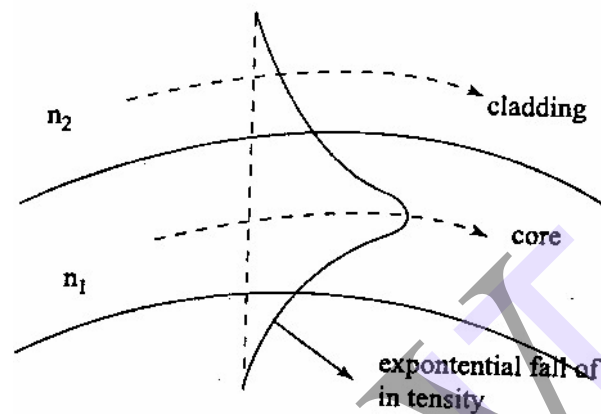

Attenuation loss is generally measured in terms of decibels (dB), which is a logarithmic unit.

$$\text{Loss of optical power} = -10 \log (P_{\text{out}} / P_{\text{in}}) \text{ dB}$$

Where  $P_{\text{out}}$  is the power emerging out of the fiber

$P_{\text{in}}$  is the power launched into the fiber.

### Optical fiber in communication systems as a wave guide:

An efficient optical fiber communication system requires high information carrying capacity fast operating speed over long distances with minimum number of repeaters. An optical fiber communication system mainly contains

1. Encoder
2. Transmitter
3. Wave guide
4. Receiver
5. Decoder.



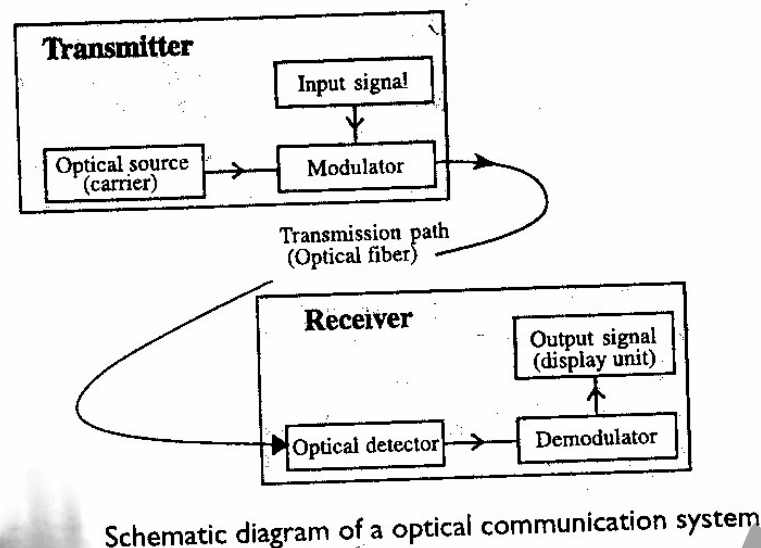

Encoder:-

It is an electronic system that convert the analog information like voice, figure, objects etc into binary data. This binary data contain a series of electrical pulses.

Transmitter:-

It consist of two parts namely drive circuit and light source .Drive circuit supplies electric signals to the light source from the encoder in the required form. In the place of light source either an LED or A diode Laser can be used ,which converts electric signals into optical signals. With the help of specially made connector optical signal will be injected into wave guide from the transmitter.

Wave guide:-

It is an optical fiber which carries information in the form of optical signals over long distances with the help of repeaters. with the help of specially made connector optical signal will be received by the receiver from the wave guide.

Receiver:-

It consists of three parts namely photo detector, amplifier and signal restorer. The photo detector converts the optical signals into equivalent electric signals and supply them to amplifier. The amplifier amplifies the electric signals as they become weak during the journey trough the wave guide over a long distances. The signal restorer keeps all the electric signals in sequential form and supplies to decoder in suitable way.

Decoder:-

It convert the received electric signals into the analog information.

### Advantages of optical fiber communication:

➤ Enormous Band width:-

In the coaxial cable transmission the band width is up to around 5000MHz only where as in fiber optical communication it is as large as  $10^5$  GHz. Thus the information carrying capacity of optical fiber system is far superior to the copper cable system.

➤ Electrical isolation:-

Since fiber optic material are insulators unlike there metallic counterpart, they do not exhibit earth loop and interface problems. Hence communication through fiber even in electrically hazarders environment do not cause any fear of spark hazards.

➤ Immunity to interference and cross talk:-

Since optical fibers are dielectric waveguides, they are free from any electromagnetic interference (EMI) and radio frequency interference (RIF). Hence fiber cable do not require special shielding from EMI. Since optical interference among different fiber is not possible ,unlike communication using electrical conductors cross talk is negligible even when many fibers are cabled together.

➤ Signal security:-

Unlike the situation with copper cables a transmitted optical signal can not be drawn fiber with out tampering it. Such an attempt will affect the original signal and hence can easily detected.

➤ Small size and weight:-

Since fibers are very small in diameter the space occupied the fiber cable is negligibly small compare to metallic cables. Optical cables are light in weight , these merits make them more useful in air crafts and satellites.

➤ Low transmission loss:-

Since the loss in fibers is as low as 0.2dB/Km , transmission loss is very less compare to copper conductors. Hence for long distance communication, fibers are preferred. Number of repeaters required is reduced.

➤ Low cost:-

Since fibers are made up of silica which is available in nature ,optical fibers are less expensive.

### **Applications of optical fibers:**

- Optical fibers are used as sensors
- These are used in Endoscopy
- These are used in communication system
- For decorative peaces in home needs.
- These are used in defence areas for the sake of high security.
- These are used in electrical engineering.

## UNIT- VIII

### 14. ACOUSTICS OF BUILDINGS & ACOUSTIC QUIETING

#### REVERBERATION AND REVERBERATION TIME

A room with hard walls no furniture and no drapes , echoes. To hear well in a room or auditorium it may seem that the walls should not absorb and sound .This would lead to echoing .A room especially a large room with an excess of sound absorbing materials such as large soft drapes and soft stuffed furniture may have a quality referred to as dead. Too much absorption results in too low an intensity. Both these types of rooms are called poor acoustics. A balance must be there fore obtained.

When the sound is switched on intensity slowly builds up when it is switched off the intensity drops slowly . The prolongation of sound inside a room or hall even after the source producing the sound is turned off is called reverberation this is due to multiple reflections from the walls ceiling floor and other reflecting materials present in the hall.

The reverberation time for a room is the time required for the intensity to drop to one millionth ( $10^{-6}$ ) of its initial value.

Reverberation time can be expressed interms of sound levels (in dB ) rather than intensity . If the initial intensity is  $I_i$  and the final intensity  $I_f$  is  $10^{-6} I_i$  then

$$\begin{aligned} dB_i &= 10 \log I_i / I \text{ (standard)} \\ dB_f &= 10 \log I_f / I \text{ (standard)} \\ dB_i - dB_f &= 10 \log ( I_i / I_f ) \\ \text{since } I_i / I_f &= 10^6 \\ dB_i - dB_f &= 10 \log 10^6 \\ &= 6 * 10 = 60 \end{aligned}$$

The reverberation time is the time required for the intensity to drop by 60 decibels . It depends on the volume  $V$  of the room. It also depends on the absorption of all parts of the room of the room walls furniture people and so forth . Some parts may be highly absorbent and some absorb only little.

#### BASIC REQUIREMENTS OF ACOUSTICALLY GOOD HALL

The reverberation of sound in an auditorium is mainly due to multiple reflections at various surfaces inside. The volume and the shape of the auditorium and the sound absorption inside influence the behaviour of sound. By varying the absorption of sound inside the hall the reverberation time can be brought to optimum value. The following are the basic requirements of acoustically good hall.

1) The volume of the auditorium is decided by the type of programme to be conducted there and also the number of seats to be accommodated. A musical hall requires a large volume whereas a lecture hall requires a smaller volume. In deciding the volume of the hall its height plays an important role than its length and breadth. The ratio between the ceiling

height and breadth should in deciding the volume of the hall the following guidelines may be followed.

- i) In cinema theatres – 3.74 to 4.2 m<sup>3</sup> per seat
  - ii) In lecture halls – 2.8 to 3.7 m<sup>3</sup> per seat
  - iii) In musical halls – 4.2 to 5.6 m<sup>3</sup> per seat
- 2) The shape of the wall and ceiling should be so as to provide uniform distribution of sound throughout the hall. The design of a hall requires smooth decay and growth of sound. To ensure these factors the hall should have scattering objects walls should have irregular surface and walls must be fixed with absorptive materials. In fig 5.1 a design which enables uniform distribution of sound is presented.
  - 3) The reverberation should be optimum i.e. neither too large nor too small. The reverberation time should be 1 to 2 seconds for music and 0.5 to 1 second for speech to control the reverberation the sound absorbing materials are to be chosen carefully.
  - 4) The sound heard must be sufficiently loud in every part of the hall and no echoes should be present.
  - 5) The total quality of the speech and music must be unchanged i.e. the relative intensities of the several components of a complex sound must be maintained.
  - 6) For the sake of clarity the successive syllables spoken must be clear and distinct i.e. there must be no confusion due to overlapping of syllables.
  - 7) There should be no concentration of sound in any part of the hall.
  - 8) The boundaries should be sufficiently sound proof to exclude extraneous noise.
  - 9) There should be no Echelon effect.
  - 10) There should be no resonance within the building.
  - 11) The hall must be full of audience.

### ABSORPTION COEFFICIENT

Since different materials absorb sound energy differently absorption of all the materials are expressed in terms of absorption coefficient.

The coefficient of absorption of a material is defined as the ratio of sound energy absorbed by the surface to that of the total sound energy incident on the surface.

$$\text{i.e. Absorption coefficient } a = \frac{\text{Sound energy absorbed by the surface}}{\text{Total sound energy incident on the surface}}$$

As all sound waves falling on an open window pass through an open window is taken to be a perfect absorber of sound and absorption coefficient of all substance are measured in terms of open window unit (O. W. U) Absorption coefficient of a surface is also defined as the reciprocal of its area which absorbs the same sound energy as absorbed by unit area of an

open window. The absorption coefficient of a given material depends on the frequency of the sound also . It is generally higher at higher frequencies.

Sound absorption coefficient of some materials (at 500 Hz frequency range)

Material	Absorption coefficient O.W.U
Marble	0.01
Concrete	0.17
Cork	0.23
Asbestos	0.26
Carpet	0.30
Fibre board	0.50
Heavy curtains	0.50
Fibre glass	0.75
Perforated cellulose fibre tiles	0.80
Human body	0.50
Open window	1.0

### SABINE'S FORMULA FOR REVERBERATION TIME

Now we are going to derive an expression for reverberation time inside a room of volume  $V$ . Sound is produced by a source inside the room. There sound waves spread and fall on the walls they are partly absorbed and partly reflected . The sound energy inside the room at any instant is given by

Rate of growth of energy in the space = rate of supply of energy by the source –  
Inside the room rate of absorption by all the surface

After getting an expression for the above if we switch off the source supplying energy then due to absorption of energy by all the surfaces energy inside the room will decay and from the decay rate reverberation time can be calculated. This derivation is based on the assumption that there is a uniform distribution of sound energy inside the room.

#### 1) Rate of supply of energy by the source

Rate of supply of energy by the source is nothing but the power of the source  $P$ .

#### 2) Rate of absorption of sound inside the room

In order to calculate the absorption by the wall we consider a small element  $ds$  on a plane wall  $AB$  as shown in fig 5.2 this element receives sound energy from the volume in front of it Energy received by this element per second can be calculated by constructing a hemisphere around this element with radius ' $v$ ' where  $v$  is the velocity of sound . Energy from every volume element with in this hemisphere will reach the element  $ds$  per elements  $ds$  . From the same centre with radii  $\gamma$  and  $\gamma+d\gamma$  two circles are drawn in the plane containing the normal. At angles  $\theta$  and  $\theta +d\theta$  with respect to the normal two radii are and the area (shaded in the figure) enclosed by these two radii between the circle is considered.

The are length of this area = $rd\theta$

Radial length = $dr$

Hence surface area of this element =  $r d\theta dr$

This surface element is rotated about the normal through an angle  $d\Phi$  and the circumferential distance moved by this elements is  $r \sin\theta d\Phi$ .

Volume traced out by this area element = area of the element \* distance moved

$$\begin{aligned} dV &= r d\theta dr (r \sin\theta d\Phi) \\ &= r^2 \sin\theta d\theta dr d\Phi \end{aligned}$$

If  $E$  is the sound energy density i.e. energy per unit volume then energy present in the is volume =  $E dV$ . Since the sound energy from this volume element propagates in all directions (i.e. through solid angle  $4\pi$ )

The energy traveling per unit solid angle =  $\frac{E dV}{4\pi}$

The energy traveling towards surface element  $ds$  alone falls on  $ds$ .

The energy traveling towards  $ds$  = energy traveling per unit solid angle \* solid angle subtended by  $ds$  at the volume element  $dV$

The solid angle subtended by area  $ds$  at this elements of volume  $dV$  =  $\frac{ds \cos\theta}{r^2}$

Hence energy traveled towards  $ds$  from the Volume element  $dV$  =  $\frac{E dV}{4\pi} \cdot \frac{ds \cos\theta}{r^2}$

$$= \frac{E \cdot r^2 \sin\theta d\theta dr d\Phi}{4\pi} \cdot \frac{ds \cos\theta}{r^2}$$

$$= \frac{E ds}{4\pi} \sin\theta \cos\theta d\theta d\Phi dr$$

Total energy received by  $ds$  in one second from the whole

$$\text{Volume in its front} = \frac{E ds}{4\pi} \int \sin\theta \cos\theta d\theta d\Phi dr$$

This equation has three variable since we consider the energy received per second  $r$  varies between  $0$  and  $v$  where  $v$  is the velocity of sound  $\theta$  varies between  $0$  and  $\pi/2$ ,  $\Phi$  varies between  $0$  and  $2\pi$ .



Hence energy received by ds per second

$$= \frac{E ds}{4\pi} \int_0^{\pi/2} \sin\theta \cos\theta d\theta \int_0^{\pi/2} d\Phi \int_0^v dr$$

$$= \frac{E ds}{4\pi} v * 2\pi * \int_0^{\pi/2} \sin\theta \cos\theta d\theta$$

$$= \frac{E v ds}{4} \int_0^{\pi/2} 2 \sin\theta \cos\theta d\theta$$

$$= \frac{E v ds}{4} (\text{since } \int_0^{\pi/2} 2 \sin\theta \cos\theta d\theta = 1)$$

If  $a$  is the absorption coefficient of the material of the wall AB then energy absorbed by the surface element ds per second

$$= \frac{E v ds}{4} a$$

Hence total rate of absorption by all the surfaces of the wall

$$= \frac{E v}{4} \Sigma a ds$$

$$= \frac{E v A}{4}$$

Where  $\Sigma a ds = A$  the total absorption  $a$  on all the surface on which sound falls.

### 3) The growth and decay of sound energy in the room

Let  $p$  be the power output i.e. rate of emission of energy from the surface and  $V$  the total volume of the room. Then the total energy in the room at the instant when energy density is  $E$  will be  $EV$

$$\text{Rate of growth of energy} = \frac{d}{Dt} (EV) = V \frac{dE}{dt}$$

But at any instant rate of growth of energy in space = rate of supply of energy from the surface – rate of absorption by all the surfaces.

$$V \frac{dE}{dt} = p - \frac{E v A}{4}$$

$$\frac{dE}{dt} = 4$$

When steady state is attained  $dE/dt = 0$  and if the steady state energy density is denoted by  $E_m$  then its value is given by

$$0 = p - \frac{E_m v A}{4}$$

$$E_m = \frac{4p}{vA}$$

from equation

$$\frac{dE}{Dt} = \frac{p}{v} - \frac{vA}{4v} E$$

(Let  $\frac{vA}{4v} = \alpha$  and hence  $\frac{1}{v} = \frac{4\alpha}{vA}$ )

$$\frac{dE}{dt} = \frac{4p\alpha}{vA} - \alpha E$$

or

$$\frac{dE}{dt} + \alpha E = \frac{4p}{vA} \alpha$$

multiplying both sides by  $e^{\alpha t}$  we have

$$\left( \frac{dE}{Dt} + \alpha E \right) e^{\alpha t} = \frac{4p}{vA} \alpha e^{\alpha t}$$

Or

$$\frac{d}{dt} (E e^{\alpha t}) = \frac{4p}{vA} \alpha e^{\alpha t}$$

integrating the above equation we get

$$E e^{\alpha t} = \frac{4p}{vA} e^{\alpha t} + k$$

where  $k$  is a constant of integration. Using the boundary conditions we can find the value of  $K$

- i) Growth of the energy density:- If  $t$  is measured from the instant the source start emitting sound. then initial condition is that at  $t=0$   $E=0$ , Applying this condition to equation we get

$$K = \frac{-4p}{vA}$$

substituting this value in equation we get

$$E e^{\alpha t} = \frac{4p}{vA} e^{\alpha t} - \frac{4p}{vA} \quad \text{or} \quad E = \frac{4p}{vA} - \frac{4p}{vA} e^{-\alpha t}$$

$$E = \frac{4p}{vA} (1 - e^{-\alpha t})$$

or

$$E = E_m (1 - e^{-\alpha t})$$

The equation shows the growth of energy with time  $t$ . The growth is along the exponential curve shown in fig 5.3 which shows that  $E$  increases along the curve with time. At  $t=0$ ,  $E=0$  and at

- ii) Decay of energy density:- Let the source be cut off when  $E$  has reached the maximum value  $E_m$ . Now at  $t=0$ ,  $p=0$ ,  $E=E_m$  from equation  $K = E_m$

substituting this value of  $K$  in equation

$$E e^{\alpha t} = E_m \quad (\text{since } p=0)$$

Equation shows the decay of the energy density with time after the source is cut off. This decay is shown by the exponential curve.

- 4) Deduction of standard reverberation time ( $T$ ) i.e. sabine's formula: We know that the persistence of audible sound in the room even after the source has stopped producing the sound is called reverberation and the standard time of reverberation  $T$  is defined as the time taken for the sound energy density inside a room to fall to one millionth of its initial maximum value hence to calculate  $T$  we put  $E_m/E = 10^6$  and  $t=T$  in equation

$$\frac{E}{E_m} = e^{-\alpha T} \cdot 10^{-6} \quad (\text{or}) \quad e^{\alpha T} = 10^6$$

Taking log we have

$$\alpha T = 6 \log_e 10 = 2.3026 * 6$$

substituting for  $\alpha$

$$T = \frac{4 * 2.3026 * 6}{330} \frac{V}{A} \quad (v=330\text{m/s})$$

Or

$$T = \frac{0.165V}{A} = \frac{0.165V}{\Sigma aS}$$

This equation is in good agreement with the experimental values obtained by sabine .this is sabine's formula for reverberation time .

- i) Directly proportional to the volume of the auditorium
- ii) Inversely proportional to the areas of sound absorbing surfaces such as ceiling wall floor and other materials present inside the hall and
- iii) Inversely proportional to the total absorption

It has been experimentally found that the reverberation time of 1.03 second is most suitable for all room having approximately a volume less that 350 meters.

#### METHOD 1

The first method is based on the determination of standard time of reverberation in the room without and with the sample of the material inside the room , If  $T_1$  is the reverberation time without the sample inside the room then applying sabine's formula

$$\frac{1}{T_1} = \frac{A}{0.165V} = \frac{\Sigma aS}{0.165V}$$

Now with the sample inside the room reveration time  $T_2$  is measured.

$$\frac{1}{T_2} = \frac{\Sigma aS + a_1 S_1}{0.165V}$$

Where  $a_1$  is the absorption coefficient of the area  $S_1$ . From the above equation we have

$$\frac{a_1 S_1}{0.165V} = \left( \frac{1}{T_2} - \frac{1}{T_1} \right)$$

OR

$$a_2 = \frac{0.165 V}{S_1} \left( \frac{1}{T_2} - \frac{1}{T_1} \right)$$

Hence knowing the terms on the right hand side of this equation the absorption coefficient  $a_1$  of the given material can be calculated .

### FACTORS AFFECTING THE ARCHITECTURAL ACOUSTICS AND THEIR REMEDIES

By an acoustically good hall we mean that every syllable or musical note reaches an audible level of loudness at every point of the hall and then quickly dies away to make Room for for the next syllable or group of note. The deviation from this makes the hall defective acoustically . Following factors affect the architectural acoustics.

1) In a hall when reverberation is large there is overlapping of successive sound which results in loss of clarity in hearing. On the other hand if the reverberation is very small the loudness is inadequate . Thus the time of reverberation for a hall should neither be too large nor too small . It must have a definite value which may be satisfactory both to the speaker as well as to the audience . The preferred value of the time or reverberation is called the optimum reverberation time . A formula for standard time of reverberation was given by W. C sabine which is

$$T = \frac{0.165V}{A} = \frac{0.165V}{\Sigma aS}$$

Where  $A$  is the total absorption of the hall  $V$  its volume in cubic metre and  $S$  is the surface area in square metre.

Experimentally its is observed that the time of reverberation depends upon the size of the hall loudness of sound and on the kind of the music fro which the hall is used . For a frequency of 512  $H_z$  the best time of reverberation lies between 1 and 1.5 sec for small halls and up to 2-3 seconds for larger ones.

**REMEDY:-** The reverberation can be controlled by the following factors

- 1) By providing windows and ventilators which can be opened and closed to make the value of the time of reverberation optimum
- 2) Decorating the walls by pictures and maps
- 3) Using heavy curtains with folds
- 4) By lining the walls with absorbent materials such as felt celotex fibre board glass wool etc
- 5) Having full capacity of audience (please remember that empty hall reverberate each person is equivalent to about 0.50 sq metre area of an open window)
- 6) By covering the floor with carpets
- 7) By providing acoustic tiles.

**LOUDNESS:-** With large absorption the time of reverberation will be smaller. This will minimise the chances of confusion between the different syllables by the intensity of sound may go below the level of intelligibility of hearing . Sufficient loudness at every point in the hall is an important factor for satisfactory hearing .

REMEDY:- The loudness may be increased by

- 1) Using large sounding boards behind the speaker and facing the audience large polished wooden reflecting surfaces immediately above the speaker are also helpful
- 2) Low ceiling are also of great help in reflecting the sound energy towards the audience.
- 3) By providing additional sound energy with the help of equipments like loud speakers. To achieve uniform distribution of intensity through out the hall loudspeakers are to be positioned carefully .

FOCUSSING:-If there are focusing surface such as concave spherical cylindrical or parabolic ones on the walls or ceiling of the hall they produce concentration of sound in particular regions while in come other parts no sound reaches at all. In this way there will be regions of silence or poor audibility . If there are extensive reflecting surfaces in the hall the reflected and direct sound waves may form stationary wave system thus making the sound intensity distribution bad and uneven.

REMEDY:- For uniform distribution of sound energy in the hall

- 1) There should be no curved surfaces . If such surfaces are present they should be covered with absorbent material
- 2) Ceiling should be low .
- 3) A paraboloidal reflected surface arranged with the speaker at the focus is also helpful in sending a uniform reflected beam of sound in the hall.

ECHOES:- An echo is heard when direct sound waves coming from the source and its reflected wave reach the listener with a time interval of about  $1/7$  second/ The reflected sound arriving earlier than this helps in raising the loudness while those arriving later produce echoes and cause confusion

REMEDY :- Echoes may be avoided by covering the long distant walls and high ceiling with absorbent material

ECHELON EFFECT:- A set of railing s or any regular spacing of reflecting surfaces may produce a musical note due to the regular succession of echoes of the original sound to the listener. This makes the original sound confusing or unintelligible .

REMEDY:- So this type of surface should be avoided or covered with proper sound absorbing materials.

RESONANCE:- Sometimes the window panes sections of the wooden portions and walls lacking in rigidity ate thrown into forced vibrations and create sound. For some note of audio frequency the frequencies of forced vibrations any be the same thus resulting in the resonance . Moreover if the frequency of the of the created sound is not equal to the original sound at least certain tone s of the original music will be reinforced. Due to the interference between original sound and created sound the original sound is distorted . Thus the intensity of the note is entirely different from the original one enclosed air in the hall also causes resonance.

REMEDY:- Such resonant vibrations should be suitably damped.

NOISE:- Generally there are three types of noises which are very troublesome they are

- 1) Air- borne noise
- 2) Structure borne noise and
- 3) Inside noise

The prevention of the transmission of noise inside or outside the hall is known as sound insulation. This is also known as sound proofing. The method of sound insulation depends on the type of noise to be treated. Here we shall discuss the different types of noises and their sound insulation.

**AIR BORNE NOISE:-** The noise which commonly reaches the hall from outside through open window doors and ventilators is known as air born noise since this noise is transmitted through the air it is called so.

**REMEDY :-** Sound insulation for the reduction of air borne noise can be achieved by the following methods

- 1) By allotting proper places for doors and windows
- 2) By making arrangements for perfectly shutting doors and windows
- 3) Using heavy glass in doors windows and ventilators
- 4) Using double doors and window with separate frames and having insulating material between them
- 5) By providing double wall construction floating floor construction suspended ceiling construction box type construction etc.
- 6) By avoiding opening s for pipes and ventilators

**STRUCTURE BORNE NOISE:-** The noise which are conveyed through the structures of the building are known as structural noise. The noises may be caused due to structure. The most common sources of this type of sound are foot steps street traffic operating machinery moving of furniture etc

**REMEDY:-** Sound insulation for the reduction of structures borne noise is done in the following ways

- 1) Breaking the continuity by interposing layers of some acoustical insulators
- 2) Using double walls with air space between them
- 3) Using anti vibration mounts
- 4) Soft floor finish (carpet rubber etc)
- 5) Mechanical equipments such as refrigerators lifts fans etc. Produce vibrations in the structure. These vibrations can be checked by insulating the equipment properly

**INSIDE NOISE:-** The noise which are produced inside the hall or rooms in big offices are called as inside noises. They are produced due to machinery like air conditioners type writers in the hall.

**CONCLUSION:-** Acoustics of buildings is a very important fields. If proper care is not taken to achieve required acoustical properties in a building the building becomes unusable. Hence at the planning stage itself it is essential to take necessary to achieve optimum reverberation time.



## 15. NANOTECHNOLOGY

### Introduction

In 1959, Richard Feynman made a statement 'there is plenty of room at the bottom'. Based on his study he manipulated smaller units of matter. He prophesied that "we can arrange the atoms the way we want, the very atoms, all the way down". The term 'nanotechnology' was coined by Norio Taniguchi at the University of Tokyo. Nano means  $10^{-9}$ . A nano metre is one thousand millionth of a metre (i.e.  $10^{-9}$  m).

Nanomaterials could be defined as those materials which have structured components with size less than 100nm at least in one dimension. Any bulk material we take, its size can express in 3-dimensions. Any planer material, its area can be expressed in 2-dimension. Any linear material, its length can be expressed in 1-dimension.

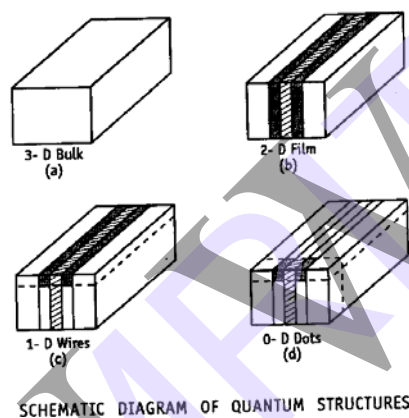

Materials that are nano scale in 1-dimension or layers, such as thin films or surface coatings.

Materials that are nano scale in 2-dimensions include nanowires and nanotubes.

Materials that are nano scale in 3- dimensions are particles like precipitates, colloids and quantum dots.

**Nanoscience:** it can be defined as the study of phenomena and manipulation of materials at atomic, molecular and macromolecular scales, where properties differ significantly from those at a larger scale.

**Nanotechnology:** It can be defined as the design, characterization, production and application of structures, devices and systems by controlling shape and size at the nano metre scale. It is also defined as "A branch of engineering that deals with the design and manufacture of extremely small electronic circuits and mechanical devices built at molecular level of matter. Now nanotechnology crosses and unites academic fields such as Physics, Chemistry and Computer science.

### Properties of nano particles:

The properties of nano scale materials are very much different from those at a larger scale. Two principal factors that cause that the properties to differ significantly are increased relative surface area and quantum effects. These can enhance or change properties such as reactivity, strength and electrical characteristics.

## 1. Increase in surface area to volume ratio

Nano materials have relatively larger surface area when compared to the volume of the bulk material.

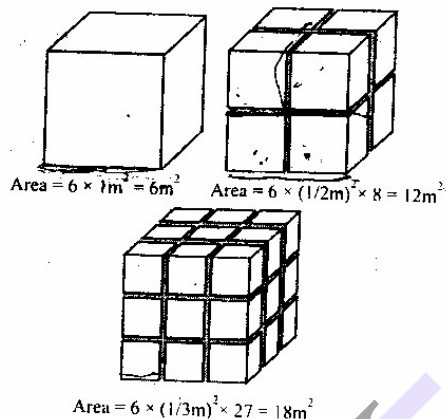

Consider a sphere of radius  $r$

Its surface area =  $4\pi r^2$

Its volume =  $\frac{4\pi r^3}{3}$

$$\frac{\text{Surface area}}{\text{Volume}} = \frac{4\pi r^2}{\frac{4\pi r^3}{3}} = \frac{3}{r}$$

Thus when the radius of sphere decreases, its surface area to volume ratio increases.

EX: For a cubic volume,

$$\text{Surface area} = 6 \times 1\text{m}^2 = 6\text{m}^2$$

When it is divided into 8 pieces

$$\text{Its surface area} = 6 \times (1/2\text{m})^2 \times 8 = 12\text{m}^2$$

When the same volume is divided into 27 pieces,

$$\text{Its surface area} = 6 \times (1/3\text{m})^2 \times 27 = 18\text{m}^2$$

Therefore, when the given volume is divided into smaller pieces, the surface area increases.

Hence as particle size decreases, greater proportions of atoms are found at the surface compared to those inside. Thus nano particles have much greater surface to volume ratio. It makes material more chemically reactive.

As growth and catalytic chemical reaction occur at surfaces, then given mass of material in nano particulate form will be much more reactive than the same mass of bulk material. This affects their strength or electrical properties.

## 2. Quantum confinement effects

When atoms are isolated, energy levels are discrete or discontinuous. When very large number of atoms is closely packed to form a solid, the energy levels split and form bands. Nano materials represent intermediate stage.

When dimensions of potential well and potential box are of the order of deBroglie wave length of electrons or mean free path of electrons, then energy levels of electrons changes. This effect is called Quantum confinement effect.

When the material is in sufficiently small size, organization of energy levels into which electrons can climb or fall changes. Specifically, the phenomenon results from electrons and holes being squeezed into a dimension that approaches a critical quantum measurement called the exciton Bohr radius. These can affect the optical, electrical and magnetic behaviour of materials.

## Variations of properties of nano materials

The physical, electronic, magnetic and chemical properties of materials depend on size. Small particles behave differently from those of individual atoms or bulk.

**Physical properties:** The effect of reducing the bulk into particle size is to create more surface sites i.e. to increase the surface to volume ratio. This changes the surface pressure and results in a change in the inter particle spacing. Thus the inter atomic spacing decreases with size.

The change in the inter particle spacing and the large surface to volume ratio in particle have a combined effect on material properties. Variation in the surface free energy changes the chemical potential. This affects the thermodynamic properties like melting point. The melting point decreases with size and at very small sizes the decrease is faster.

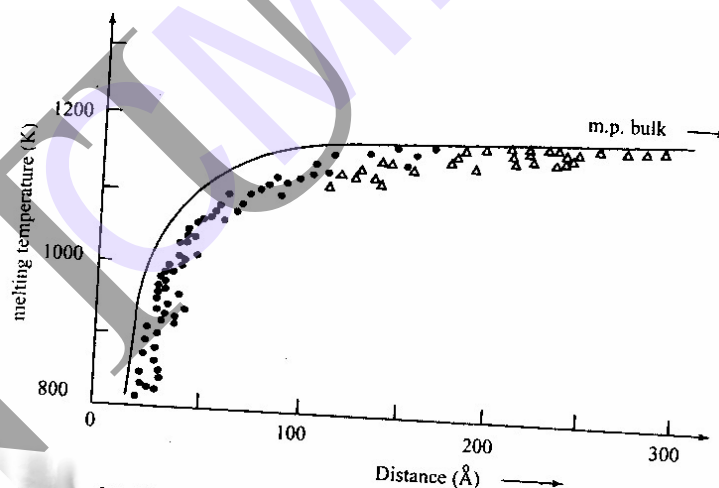

**Chemical properties:** the large surface to volume ratio, the variations in geometry and electronic structure has a strong effect on catalytic properties. The reactivity of small clusters increases rapidly even when the magnitude of the cluster size is changed only by a few atoms.

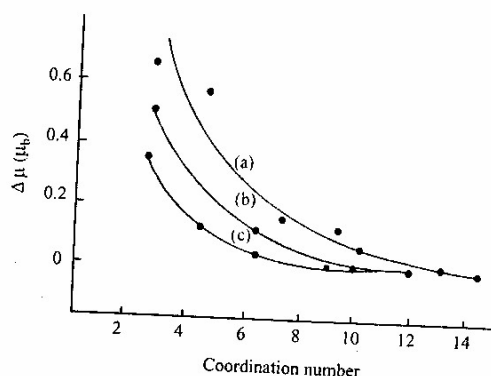

Another important application is hydrogen storage in metals. Most metals do not absorb, hydrogen is typically absorbed dissociatively on surfaces with hydrogen- to- metal atom ratio of one. This limit is significantly enhanced in small sizes. The small positively charged clusters of Ni, Pd and Pt and containing between 2 and 60 atoms decreases with increasing cluster size. This shows that small particles may be very useful in hydrogen storage devices in metals.

**Electrical properties:** The ionization potential at small sizes is higher than that for the bulk and show marked fluctuations as function of size. Due to quantum confinement the electronic bands in metals become narrower. The delocalized electronic states are transformed to more localized molecular bands and these bands can be altered by the passage of current through these materials or by the application of an electric field.

In nano ceramics and magnetic nano composites the electrical conductivity increases with reduction in particle size whereas in metals, electrical conductivity decreases.

**Optical properties:** Depending on the particle size, different colours are same. Gold nano spheres of 100nm appear orange in colour while 50nm nano spheres appear green in colour. If semiconductor particles are made small enough, quantum effects come into play, which limits the energies at which electrons and holes can exist in the particles. As energy is related to wavelength or colour, the optical properties of the particles can be finely tuned depending on its size. Thus particles can be made to emit or absorb specific wavelength of light, merely by controlling their size.

An electro chromic device consist of materials in which an optical absorption band can be introduced or existing band can be altered by the passage of current through the materials, or by the application of an electric field. They are similar to liquid crystal displays (LCD) commonly used in calculator and watches. The resolution, brightness and contrast of these devices depend on tungstic acid gel's grain size.

**Magnetic properties:** The strength of a magnet is measured in terms of coercivity and saturation magnetization values. These values increase with a decrease in the grain size and an increase in the specific surface area (surface area per unit volume) of the grains.

In small particle a large number or fraction of the atoms reside at the surface. These atoms have lower coordination number than the interior atoms. As the coordination number decreases, the moment increases towards the atomic value there is small particles are more magnetic than the bulk material.

Nano particle of even non magnetic solids are found to be magnetic. It has been found theoretically and experimentally that the magnetism special to small sizes and disappears in clusters. At small sizes, the clusters become spontaneously magnetic.

**Mechanical properties:** If the grains are nano scale in size, the interface area with in the material greatly increases, which enhances its strength. Because of the nano size many mechanical properties like hardness, elastic modulus, fracture toughness, scratch resistance, fatigue strength are modified.

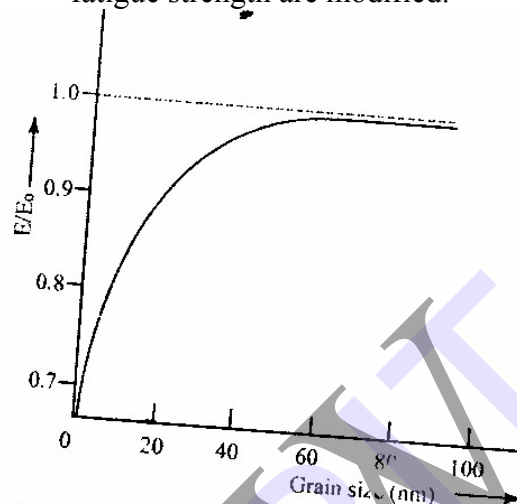

The presence of extrinsic defects such as pores and cracks may be responsible for low values of E (young's modulus) in nano crystalline materials. The intrinsic elastic moduli of nano structured materials are essentially the same as those for conventional grain size material until the grain size becomes very small. At lower grain size, the no. of atoms associated with the grain boundaries and triple junctions become very large. The hardness, strength and deformation behaviour of nano crystalline materials is unique and not yet well understood.

Super plasticity is the capability of some polycrystalline materials to exhibit very large texture deformations without fracture. Super plasticity has been observed occurs at somewhat low temperatures and at higher strain rates in nano crystalline material.

#### **PRODUCTION OF NANOMATERIALS:**

Material can be produced that are nanoscale in one dimension like thin surface coatings in two dimensions like nanowires and nanotubes or in 3 dimensions like nanoparticles

Nano materials can be synthesized by 'top down' techniques producing very small structures from larger pieces of material. One way is to mechanical crushing of solid into fine nano powder by ball milling.

Nanomaterials may also be synthesized by 'bottom up' techniques, atom by atom or molecule by molecule. One way of doing this is to allow the atoms or molecules arrange themselves into a structure due to their natural properties

Ex: - Crystals growth

## PERPARATION:

There are many methods to produce nanomaterials. They are

### 1). *PLASMA ARCING:*

Plasma is an ionized gas. To produce plasma, potential difference is applied across two electrodes. The gas yields up its electrons and gets ionized. Ionized gas (plasma) conducts electricity. A plasma arcing device consists of two electrodes. An arc passes from one electrode to the other. From the anode electrode due to the potential difference electrons are emitted. Positively charged ions pass to the other electrode (cathode), pick up the electron and are deposited to form nanoparticles. As a surface deposit the depth of the coating must be only a few atoms. Each particle must be nanosized and independent. The interaction among them must be by hydrogen bonding or Vander Waals forces. Plasma arcing is used to produced carbon nanotubes.

### 2). *CHEMICAL VAPOUR DEPOSITION:*

In this method, nanoparticles are deposited from the gas phase. Material is heated to from a gas and then allowed to deposit on solid surface, usually under vacuum condition. The deposition may be either physical or chemical. In deposition by chemical reaction new product is formed. Nanopowder or oxides and carbides of metals can be formed, if vapours of carbon or oxygen are present with the metal.

Production of pure metal powders is also possible using this method. The metal is meted exciting with microwave frequency and vapourised to produce plasma at  $1500^{\circ}\text{c}$ . This plasma then enters the reaction column cooled by water where nanosized particles are formed.

CVD can also be used to grow surfaces. If the object to be coated is introduced inside the chemical vapour, the atoms/molecules coated may react with the substrate atoms/molecules. The way the atoms /molecules grow on the surface of the substrate depends on the alignment of the atoms /molecules of the substrate. Surfaces with unique characteristics can be grown with these techniques.

### 3. Sol – Gels:

Sol: - A material which when reacts with liquid converts in to a gelly or viscous fluid.

Colloid:- A substance which converts liquid to semisolid or viscous or cloudy.

Gel : Amore thickly substance.

Soot :- When a compound is brunt, it given black fumes called soot.

In solutions molecules of nanometer size are dispersed and move around randomly and hence the solutions are clear. In colloids, the molecules of size ranging from  $20\mu\text{m}$  to  $100\mu\text{m}$  are suspended in a solvent. When mixed with a liquid colloids look cloudy or even milky. A colloid that is suspended in a liquid is called as sol. A suspension that keeps its

shape is called a gel. Thus sol-gels are suspensions of colloids in liquids that keep their shape. Sol -gels formation occurs in different stages.

- 1) Hydrolysis
- 2) Condensation and polymerization of monomers to form particles
- 3) Agglomeration of particles. This is followed by formation of networks which extends throughout the liquid medium and forms a gel.

The rate of hydrolysis and condensation reactions are governed by various factors such as  $P_H$ , temperature,  $H_2O/Si$  molar ratio, nature and concentration of catalyst and process of drying. Under proper conditions spherical nanoparticles are produced.

### **3. ELECTRODEPOSITION:**

This method is used to electroplate a material. In many liquids called electrolytes (aqueous solutions of salts, acids etc) when current is passed through two electrodes immersed inside the electrolyte, certain mass of the substance liberated at one electrode gets deposited on the surface of the other. By controlling the current and other parameters, it is possible to deposit even a single layer of atoms. The films thus obtained are mechanically robust, highly flat and uniform. These films have very wide range of application like in batteries, fuel cells, solar cells, magnetic read heads etc.

### **5. BALL MILLING (MECHANICAL CRUSHING):**

In this method, small balls are allowed to rotate around the inside of a drum and then fall on a solid with gravity force and crush the solid into nanocrystallites. Ball milling can be used to prepare a wide range of elemental and oxide powders. Ball milling is the preferred method for preparing metal oxides.

### **CARBON NANOTUBES (CNT'S):**

We know three forms of carbon namely diamond graphite and amorphous carbon. There is a whole family of other forms of carbon known as carbon nanotubes, which are related to graphite. In conventional graphite, the sheets of carbon are stacked on top of one another. They can easily slide over each other. That's why graphite is not hard and can be used as a lubricant. When graphite sheets are rolled into a cylinder and their edges joined, they form carbon nanotubes i.e. carbon nanotubes are extended tubes of rolled graphite sheets.



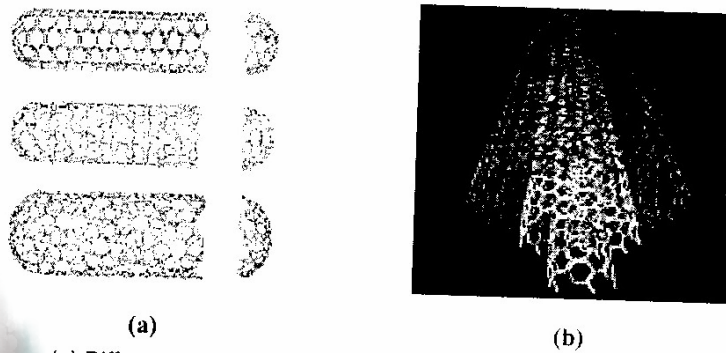

(a) Different types of single walled nanotubes (b) Multi walled nanotubes

**TYPES OF CNT'S:** A nanotube may consist of one tube of graphite, a one atom thick single wall nanotube or number of concentric tubes called multiwalled nanotubes.

There are different types of CNT'S because the graphite sheets can be rolled in different ways. The 3 types of CNT'S are ZigZag, Armchair and chiral. It is possible to recognize type by analyzing their cross sectional structures.

Multiwalled nanotubes come in even more complex array of forms. Each concentric single – walled nanotube can have different structures, and hence there are a variety of sequential arrangements. There can have either regular layering or random layering. The structure of the nanotubes influences its properties. Both type and diameter are important. The wider the diameter of the nanotube, the more it behaves like graphite. The narrower the diameters of nanotube, the more its intrinsic properties depends upon its specific type. Nanotubes are mechanically very strong, flexible and can conduct electricity extremely well.

The helicity of the graphite sheet determines whether the CNT is a semiconductor or metallic.

**PRODUCTION OF CNT'S:** There are a number of methods of making CNT'S few method adopted for the production of CNT'S.

**ARC MRTHOD:** This method creates CNT'S through arc- vapourisation of two carbon rods placed end to end, separated by 1mm, in an enclosure filled with inert gas at low pressure. It is also possible to create CNT'S with arc method in liquid nitrogen. A direct current of 50-100A, driyen by a potential difference of 20V apprx, creates a high temperature discharge between the two electrodes. The discharges vapourizes the surface of one of the carbon electrodes, and forms a small rod shaped deposit on the other electrode. Producing CNT'S in high yield depends on the uniformity of the plasma arc, and the temperatures of deposits forming on the carbon electrode.

**LASER METHOD:** CNT'S were first synthesized using a dual-pulsed laser. Samples were prepared by laser vapourizations of graphite rods with a 50:50 catalyst mixture of Cobalt & Nickel at 1200<sup>0</sup>c in flowing argon. The initial layer vapourization pulse was followed by a second pulse, to vapourize the target more uniformly. The use of two successive laser pulses minimizes the amount of carbon deposited as soot. The second laser pulse breaks up the larger particles ablated by the first one and feeds then into growing nanotube structure. The CNT'S produced by this method are 10-20nm in diameter and upto 100m or more in length. By varying the growth temperatures, the

catalyst composition and other process parameters the average nanotube diameter and size distribution can be varied.

**CHEMICAL VAPOUR DEPOSITION (CVD):** Large amount of CNT'S can be formed by catalytic CVD of acetylene over Cobalt and Iron catalysts supported on silica or zeolite. The carbon deposition activity seems to relate to the cobalt content of the catalyst; where as the CNT'S selectivity seems to be a function of the  $P_H$  in catalyst preparation. CNT'S can be formed from ethylene. Supported catalysts such as iron cobalt and Nickel containing either a single metal or a mixture of metals, seem to induce the growth of isolated single walled nanotubes or single walled nanotubes, bundles in the ethylene atmosphere. The production of single walled nanotubes as well as double walled CNT'S, molybdenum and molybdenum-iron catalysts has also been demonstrated.

**PROPERTIES OF CNT;S :** Few unique properties of CNT'S are

**1) ELECTRICAL CONDUCTIVITY:** CNT'S can be highly conducting, and hence can be said to be metallic. Their conductivity will be a function of chirality, the degree of twist and diameter. CNT'S can be either metallic or semi conducting in their electrical behaviour. Conductivity in multi walled CNT'S is more complex. The resistivity of single walled nanotubes ropes is of the order of  $10^{-4}$  ohm-cm at  $27^{\circ}\text{C}$ . This means that single walled nanotube ropes are most conductive carbon fibers. Individual single walled nanotubes may contain defects. These defects allow the single walled nanotubes to act as transistors. Similarly by joining CNT'S together forms transistor-like devices. A nanotube with natural junctions behaves as a rectifying diode.

**2) Strength and elasticity:** Because of the strong carbon bonds, the basal plane elastic modulus of graphite, it is one of the largest of any known material. For this reason, CNT'S are the ultimate high strength fibers. Single walled nanotubes are stiffer than Steel, and are very resistant to damage from physical forces.

**3) THERMAL CONDUCTIVITY AND EXPANSION:** The strong in-plane graphite carbon-carbon bonds make them exceptionally strong and stiff against axial strains. The almost zero-in-plane thermal expansion but large inter-plane expansion of single walled nanotubes implies strong in-plane coupling and high flexibility against non-axial strains. CNT'S show very high thermal conductivity. The nanotube reinforcements in polymeric materials may also significantly improve the thermal and thermo mechanical properties of composites.

**4) HIGHLY ABSORBENT:** The large surface area and high absorbency of CNT'S make them ideal for use in air, gas and water filtration. A lot of research is being done in replacing activated charcoal with CNT'S in certain ultra high purity application.

#### **APPLICATION OF NANOMATERIALS:**

- 1. Engineering:** i).Wear protection for tools and machines (anti blocking coatings, scratch resistant coatings on plastic parts). ii) Lubricant-free bearings.
- 2. Electronic industry:** Data memory(MRAM,GMR-HD), Displays(OLED,FED), Laser diodes, Glass fibres
- 3. Automotive industry:** Light weight construction, Painting (fillers, base coat, clear coat), Sensors, Coating for wind screen and car bodies.
- 4. Construction:** Construction materials, Thermal insulation, Flame retardants.

5. **Chemical industry:** Fillers for painting systems, Coating systems based on nano composites. Impregnation of papers, Magnetic Fluids.
6. **Medicine:** Drug delivery systems, Agents in cancer therapy, Anti microbial agents and coatings, Medical rapid tests Active agents.
7. **Energy:** Fuel cells, Solar cells, batteries, Capacitors.
8. **Cosmetics:** Sun protection, Skin creams, Tooth paste, Lipsticks.

### Questions:

1. What are Nanomaterials? Why do they exhibit different properties?
2. How are optical, physical and chemical properties of nano particles vary with their size.
3. How are electrical, magnetic and mechanical properties of nano particles vary with their size?
4. How are nano materials produced?
5. What are carbon nano tubes? How are they produced?
6. What are the different types of carbon nano tubes? What are their properties?
7. What are the important applications of nano materials?

### Question Bank

#### Unit-I **Bonding in solids** **Crystal Structure and Crystallography**

1. Explain with suitable examples the ionic, covalent, metallic and molecular type of bonding in solids.
2. Explain the forces between the two interacting atoms when they are brought nearer to form a molecule.
3. What is cohesive energy. Assuming a suitable model for interatomic forces derive an expression for the cohesive energy.
4. Derive an expression for the cohesive energy of an ionic crystal.
5. Illustrate graphically the variation of (i) interatomic forces (ii) potential energy with the spacing between two atoms.
6. Explain the terms (i) basis (ii) space lattice (iii) unit cell
7. Describe the seven crystal systems with diagrams.
8. Show that FCC is the most closely packed of the three cubic structures by working out the packing factors.
9. Illustrate Bravais Lattices.
10. What are Miller indices. How are they obtained.
11. Deduce the expression for the inter-planar distance in terms of Miller indices for a cubic structure.
12. Sketch the following planes of a cubic unit cell: (001),(120) and (211).
13. Find the packing factors for diamond and HCP.
14. Describe the structures of NaCl,CsCl and ZnS.

Unit-II      **X-Ray Diffraction  
Defects in crystals**

1.      (a). Why X-ray are used for crystal diffraction studies.  
          (b). State and Prove Bragg's law.
2.      Describe Laue's method of determination of crystal structure.
3.      Describe with suitable diagram, the powder method of determination of crystal structure.
4.      What are the applications of X-ray diffraction studies.
5.      What are the three experimental methods of X-ray diffraction.
6.      Briefly explain the Defects in crystals.
7.      (a). Write notes on edge dislocation and screw dislocation.  
          (b). Explain the significance of Burgers vector.
8.      Write notes on surface imperfections.
9.      Explain different types of volume defects.
10.     What are grain boundaries. What are different types of grain boundaries.
11.     Discuss Schottky Defects. Calculate the concentration for schotty defects.
12.     Write a note on point defects.

**Unit-III      Elements of Statistical Mechanics**  
**Principal of Quantum Mechanics**

1. Briefly give an comparative study of three types of statistics.
2. Derive an expression for Maxwell-boltzmann energy distribution function.
3. Derive an expression for Bose-Einstein distribution function.
4. Derive an expression for Fermi-Dirac distribution function.
5. Explain Rayleigh-Jean's law of radiation. Derive the expression for radian energy of a blackbody on the basis of Rayleigh-Jeans.
6. What is Photon gas. What are its characteristics.
7. Write short notes on Fermi energy of metal and Wien's displacement law.
8. What is an electron gas.
9. Discuss the executed feature of Plank's theory of black body radiation.
10. What are matter waves. Explain their properties.
11. Derive time independent Schrodinger's wave equation for a free particle.
12. Explain de-Broglie hypothesis. Explain G.P. Thomson's experiment in support of this hypothesis.
13. Describe Davisson and Germer's experiment and explain how it enabled the verification of wave nature of matter.
14. Assuming the time independent Schrodinger's wave equation. Discuss the solution for a particle in a one-dimensional potential well of infinite height.
15. Explain the physical significance of wavefunction.

**Unit-IV      Band Theory of Solids**

1. Explain the origin of energy bands in solids.
2. Discuss the Kronig penny model for the motion of an electron in a periodic potential.
3. Explain the concept of effective mass of an electron.
4. Explain the classification of metals, semiconductors and insulators based on band theory.
5. Explain the following:
  - (a). Drift velocity, Mobility and Relaxation time.
  - (b). Effective mass
  - (c). Bloch theorem.
6. Explain the effective mass of Hole.
7. Explain about Brillouin Zone.
8. Explain about Bloch theorem.



Unit-V      **Semiconductor Physics**  
**Physics of Semiconductor Devices**

1. Distinguish between intrinsic and extrinsic impurity semiconductors with suitable examples.
2. Derive an expression for the carrier concentration of an intrinsic semiconductor.
3. Distinguish between metals, Semiconductors and Insulators.
4. Describe the drift and diffusion currents in a semiconductor and Deduce Einstein relation.
5. Explain Hall effect and its importance.
6. Sketch the energy band diagrams of (a). an intrinsic (b). N-type (c). P-type semiconductors. Indicate Fermi, Donor and acceptor levels wherever present.
7. What is equation of continuity for semiconductors. What physical law leads to the equation of continuity.
8. Explain how a PN junction is formed. Draw I-V characteristic curve of a PN junction diode and explain.
9. With theory explain the working of a PN junction diode and derive diode equation.
10. Explain the rectifying action of a PN diode. Explain the construction and working of a wave rectifier.
11. Explain the construction and working of LED. What are the advantages and disadvantages of LEDs in electronic display.
12. Explain the characteristics of liquid crystal materials. How are they used in the construction of liquid crystal display devices.
13. Explain the construction of a Junction photodiode. Discuss the factors which limits the speed of response of photodiode.



## UNIT -7 LASERS –FIBRE OPTICS

1.
  - a) Explain the characteristics of a laser beam.
  - b) Mention any two applications of laser each in the field of scientific research. engineering and medicine.
  - c) Describe the construction and working of a Ruby laser.
2.
  - a) What do you understand by population inversion? How it is achieved?
  - b) Derive the relation between the probabilities of spontaneous emission and stimulated emission in terms of Einstein's coefficient.
3.
  - a) Explain the purpose of an active medium in a gas laser.
  - b) With the help of suitable diagrams, explain the principle, construction and working of a helium-neon laser.
4. Distinguish between spontaneous and stimulated emission process of light.
5. Explain the terms
  - a) Absorption
  - b) Spontaneous emission
  - c) Stimulated emission
  - d) pumping mechanism
  - e) Population inversion
  - f) Optical cavity
6. Describe a semiconductor laser. Give the applications of lasers.
7. Give the energy level diagram of co<sub>2</sub> Laser and explain the working of co<sub>2</sub> laser.
8.
  - a) Explain the principle of an optical fiber.
  - b) Explain how the optical fibers are classified.
9. Define numerical aperture and acceptance angle. Derive a relation between the two.
10. Describe different types of fibers by giving the refractive index and propagation details.
11. Draw the block diagram of fiber optic communication system and explain the function of each block.
12. What are the losses in optical fibers? Write brief note on each.

Unit-VIII      **Nanotechnology**  
**Acoustics of Buildings and Acoustic Quieting**

1. Define Reverberation, reverberation time and Absorption coefficient of a material.
2. Derive Sabine's formula for reverberation time.
3. What are the basic requirements of acoustically good hall.
4. Explain the various factors affecting architectural acoustics and their remedies.
5. Write a short notes on Optimum reverberation and Acoustic noise.
6. What do you mean by 'acousting quieting'.
7. What is sound proofing.
8. What are nanomaterials. Why do they exhibit different properties.
9. What are Carbon Nanotubes. How are they produced.
10. What are the different types of carbon nanotubes. What are their properties.
11. What is the principle and advantages of TEM. And explain the transmission electron microscopy.
12. What is Nanotechnology. How is it useful to society and discuss the properties of Nanomaterials.
13. List a few methods of synthesis of Nanomaterials and mention the applications of Nanomaterials.

### Objective Type Question

#### UNIT -1      **Bonding in Solids** **Crystallography and Crystal Structures**

#### Choose the correct Answer

1. At equilibrium condition the atoms possess [    ]  
 a) Maximum kinetic energy    b) minimum potential energy  
 c) Maximum potential energy d) maximum total energy
2. Primary bondings have bond energies in the range of [    ]  
 a) 0.01 - 0.5 eV      b) 10 -100 eV  
 c) 0 - 0.01 eV      d) 0.1 - 10 eV
3. Secondary bondings have bond energies in the range of [    ]  
 a) 0.01 – 0.5 eV      b) 10 – 100 Ev  
 c) 0 – 0.01 eV      d) 0.1 – 10 Ev
4. Among the following the strongest bond is [    ]  
 a) hydrogen bond    b) metallic bond  
 c) covalent bond    d) ionic bond
5. Primary bonds are formed by [    ]  
 a) inter molecular forces    b) inter atomic forces  
 c) van der waal's forces    d) none of the above
6. Bonding in diamond is [    ]  
 a) covalent      b) ionic  
 c) dipole      d) metallic
7. There are \_\_\_\_\_ basic crystal systems [    ]  
 a) four    b) five    c) six    d) seven
8. The only element exhibiting simple cubic structure is [    ]  
 a) silver    B) polonium    c) zinc    d) diamond
9. The relation between atomic radius  $r$  and lattice constant  $a$  in the case of simple cubic structure is [    ]  
 a)  $a=2r$       b)  $a=r/2$       c)  $a=4r/3$       d)  $a=2\sqrt{2}r$

10. Effective number of atoms belonging to the unit cell of BCC structure is  
a) 8      b) 1      c) 2      d) 9      [   ]

### Fill in the blanks

11. The primary bonds are  
1) \_\_\_\_\_ 2) \_\_\_\_\_ 3) \_\_\_\_\_ 4) \_\_\_\_\_
12. A melt of a solid consists of \_\_\_\_\_ order that is not stable.
13. The repulsive forces between atoms become significant only if atoms are \_\_\_\_\_ from each other.
14. Born's exponent is evaluated from the \_\_\_\_\_ studies in ionic crystals.
15. The compressibility of crystal is \_\_\_\_\_ proportional to the repulsive exponent.
16. The units of the lattice energy is \_\_\_\_\_
17. The alkali halides show absorption bands in \_\_\_\_\_ region of the Electromagnetic spectrum.
18. Amorphous substances are formed by \_\_\_\_\_ cooling of the melts Of organic compounds.
19. A glass is \_\_\_\_\_ liquid.
20. A substance in amorphous state possesses \_\_\_\_\_ viscosity.

## UNIT -2      X-Ray Diffraction Defects in Crystals

### Choose the correct Answer

1. X-ray are used for crystal diffraction studies because [    ]
  - a) they have higher penetrating power
  - b) crystals are transparent to x- rays
  - c) the inter atomic spacing is of the order of x – ray wavelength
  - d) they have high resolving power
  
2. According to Bragg ‘s law [    ]
 

a) $2\lambda \sin\theta = nd$	b) $2 \sin \theta = nd \lambda$
c) $2d \sin\theta = n \lambda$	d) $\sin \theta = nN \lambda$
  
3. Burgers vector is to indicate the magnitude of [    ]
 

a) point defects	b) line defects
c) surface defects	d) volume defect
  
4. If a foreign atom replaces a parent atom in the crystal, it is called [    ]
 

a) Frenkel defect	B) Schottky defect
c) Substitutional impurity	d) Electronic defect
  
5. In ionic crystals, an ion displaced from a regular site to an interstitial site is called [    ]
 

a) Frenkel defect	b) schottky defect
c) substitutional defect	d) electronic defect
  
6. A pair of cation and anion missing from an ionic crystal leaving vacant ion sites is called [    ]
 

a) Frenkel defect	b) schottky defect
c) substitutional defect	d) electronic defect
  
7. Twin boundary is a [    ]
 

a) point defects	b) line defects
c) surface defects	d) volume defect
  
8. When the composition of an ionic crystal does not corresponds to the exact stoichiometric formula, the \_\_\_\_\_ arise. [    ]
 

a) Frenkel defect	b) schottky defect
c) substitutional defect	d) electronic defect







- (a) 15 volts (b) 12 volts  
(c) 500 volts (d) 150 volts
9. In G.P. Thomson experiment for diffraction, the sample used for diffraction is [     ]  
(a) NaCl crystal (b) any one crystal  
(c) thin film of matter such as gold (d) none
10. Wave nature and particle nature called dual nature is exhibiting by [     ]  
(a) particles only (b) waves only  
(c) photons only (d) by particle and waves

### Fill in the blanks

11. The MB distribution function is Expressed as \_\_\_\_\_.
12. Particles with intergral spin are called \_\_\_\_\_.
13. particles with odd half-integral spins are called \_\_\_\_\_.
14. Phonons are the particles that follow \_\_\_\_\_ statistics.
15. Wien's displacements law is given as \_\_\_\_\_.
16. Electrical conduction in metals is explained by \_\_\_\_\_ theory.
17. Conduction electrons in a simple metal are known as \_\_\_\_\_ electrons.
18. The wavelength of the waves associated with particles is given by the relation \_\_\_\_\_.
19. The diffraction of electrons was demonstrated for the first time by \_\_\_\_\_.
20. The eigen values of the particle are also called \_\_\_\_\_ states.

## Unit-IV Band theory of Solids

### Choose the correct Answer

1. Drude and Lorentz developed [ ]  
(a) classical free electron theory (b) quantum free electron theory  
(c) zone theory (d) corpuscular theory
2. Sommerfeld developed [ ]  
(a) classical free electron theory (b) quantum free electron theory  
(c) zone theory (d) corpuscular theory
3. Zone theory of metals was developed by [ ]  
(a) Drude and Lorentz (b) Sommerfeld  
(c) Bloch (d) Newton
4. The steady drift velocity per unit electric field is called [ ]  
(a) mobility of the electron (b) random velocity  
(c) mean free path (d) none of these
5. The classical free electron theory was developed by [ ]  
(a) Sommerfeld (b) Bloch  
(c) Drude and Lorentz (d) Planck
6. The quantum free electron theory was developed by [ ]  
(a) Sommerfeld (b) Bloch  
(c) Drude and Lorentz (d) Planck
7. The zone theory of electron was developed by [ ]  
(a) Sommerfeld (b) Bloch  
(c) Drude and Lorentz (d) Planck
8. The periodicity of the lattice is given by [ ]  
(a) Bloch theorem (b) planck theorem  
(c) Drude and Lorentz (d) None of these
9. When the band gap is in the order of 1eV in a solid, it behaves as a [ ]  
(a) conductor (b) semiconductor [ ]  
(c) insulator (d) metal
10. When the scattering power of the potential barrier is zero, the electron is [ ]  
(a) Completely bound (b) partly bound and partly free [ ]  
(c) Completely free (d) lost due to recombination

### Fill in the blanks

11. The nature and quantity of conductivity differences between insulators and  
conductors can be explained by \_\_\_\_\_ theory.
12. In metals, there is an overlapping of \_\_\_\_\_ and \_\_\_\_\_ bands.
13. The band theory of solids deals with electron motion in a \_\_\_\_\_  
field of a crystal.
14. Near the bottom of band, the effective mass of the electron is \_\_\_\_\_  
in sign.
15. Semi metals possess \_\_\_\_\_ bands.
16. The number of energy states in a band is equal to the \_\_\_\_\_ of states.
17. The upper most band is filled with \_\_\_\_\_ electrons.
18. If an element has odd number of electrons, the upper most band will be  
\_\_\_\_\_ filled.
19. The width of the allowed band \_\_\_\_\_ with increasing binding  
energy of the electrons.
20. A hole near the top of an allowed band has \_\_\_\_\_ effective mass.

## Unit-VI Dielectric Properties Magnetic Properties

Choose the correct Answer

1. Electronic polarization [    ]  
(a) decreases with increase of temperature  
(b) increase of temperature  
(c) may decreases or increase of temperature  
(d) is independent of temperature
2. Ionic polarization [    ]  
(a) decreases with increase of temperature  
(b) increase of temperature  
(c) may decreases or increase of temperature  
(d) is independent of temperature
3. Orientational polarization [    ]  
(a) decreases with increase of temperature  
(b) increase of temperature  
(c) may decreases or increase of temperature  
(d) is independent of temperature
4. At normal temperatures, the polarizations which are independent of temperature are [    ]  
(a) electronic and ionic                      (b) ionic and orientational  
(c) orientational and space charge      (d) space charge and electronic
5. Dielectrics are [    ]  
(a) solids    (b) metals  
(c) semiconductors                              (d) insulators
6. Diamagnetic materials possess [    ]  
(a) permanent magnetic dipoles      (b) no permanent magnetic dipoles  
(c) induced dipoles along field direction  
(d) no induced diploes even when external field is applied
7. Materials do not having permanent magnetic dipoles are [    ]  
(a) paramagnetic                              (b) ferromagnetic  
(c) ferrimagnetic                              (d) diamagnetic
8. Diamagnetic susceptibility is [    ]  
(a) large , negative                              (b) small , positive  
(b) small , negative                              (d) large , positive

9. The magnetization of a superconductor is [     ]  
(a) 0            (b) H            (c) 1            (d)  $-H$
10. Theory which explains superconductivity is [     ]  
(a) lattice theory                      (b) Lorentz theory  
(c) BCS theory                         (d) sommerfeld theory

### Fill in the blanks

11. The polarization density  $P$  in a dielectric medium is proportional directly to  
The \_\_\_\_\_.
12. The polarizability of a dielectric is the ratio of \_\_\_\_\_ and the \_\_\_\_\_.
13. The units of  $D$ , the electric displacement, are \_\_\_\_\_.
14. Gauss law in electrostatics is \_\_\_\_\_.
15. The ionic polarization in an ionic solid is unaffected by the variations in \_\_\_\_\_.
16. In case of diamagnetic substances, the susceptibility is \_\_\_\_\_.
17. The SI unit of magnetic moment is \_\_\_\_\_.
18. The ratio of magnetic moment to the angular momentum of an electron is  
Called \_\_\_\_\_.
19. The exchange integral is positive for \_\_\_\_\_ substance.
20. The exchange integral is negative for \_\_\_\_\_.



## Unit-VII                      Laser    Fiber Optics

### Choose the correct Answer

1. The population of the various energy levels of a system in thermal equilibrium is given by [     ]  
(a) Boltzmann distribution law    (b) Einstein relations  
(c) Planck's law                      (d) Beer's law
2. T.Maiman invented [     ]  
(a) He-Ne laser                      (b) CO<sub>2</sub> laser  
(c) Ruby laser                        (d) Nd: YAG laser
3. The colour of the laser output from a Ruby laser is [     ]  
(a) green    (b) blue    (c) red    (d) violet
4. In He-Ne lasers, the ratio of He-Ne is in the order [     ]  
(a) 1:10    (b) 1:1    (c) 100:1    (d) 10:1
5. Laser radiation is [     ]  
(a) monochromatic                      (b) highly directional  
(c) coherent and stimulated  
(d) highly directional, monochromatic , coherent and stimulated
6. Propagation of light through fiber core is due to [     ]  
(a) diffraction    (b) interference    (c) refraction  
(d) total internal reflection
7. Step index fiber can be a [     ]  
(a) monomode fiber only                      (b) multimode fiber only  
(c) monomode as well as multimode fiber  
(d) either monomode or multimode
8. The process of mixing the signal with the carrier is called [     ]  
(a) dispersion    (b) attenuation    (c) modulation  
(d) demodulation
9. To overcome the problem of inter model dispersion one has to use [     ]  
(a) multimode fiber                      (b) step index fiber  
(c) graded index fiber                      (d) plastic fiber

10. The attenuation in an optical fiber is a function of [     ]  
(a) fiber material only                      (b) wavelength of light only  
(c) length of the fiber only                (d) all the above

### Fill in the blanks

11. A laser source is a quantum \_\_\_\_\_.
12. Generally, the laser that are used in holography are \_\_\_\_\_ laser.
13. The pumping process that is used in He-Ne lasers source is \_\_\_\_\_.
14. In He-Ne laser system, \_\_\_\_\_ ions give metastable levels.
15. Semi conductor diode gives out radiation as a results of \_\_\_\_\_ emission.
16. In a single mode fiber, there is \_\_\_\_\_.
17. In multi mode fibers, the core diameter is \_\_\_\_\_.
18. \_\_\_\_\_ fiber is a multimode fiber.
19. A glass fiber consists of a \_\_\_\_\_ glass surrounded by a \_\_\_\_\_ made of slightly of lower refractive index.
20. Single mode fibers transmit single ray \_\_\_\_\_ the axis of the fiber.

## Unit-VIII      Acoustics of Buildings and Acoustic Quieting Nanotechnology

### Choose the correct Answer

1. Optimum reverberation time for music is [     ]  
(a) 0.5 to 1 second                      (b) 0 to 1 second  
(c) 1 to 2 second                         (d) above 5 second
2. Two square meter of a fiber board absorbs sound energy as that of unit area of an open window. The absorption coefficient of fiber board is [     ]  
(a) 0.50      (b) 0.2      (c) 2      (d) 0.0825
3. The wall of a halls built for music concerns should [     ]  
(a) amplify sound                      (b) reflect sound  
(c) transmit sound                      (d) absorb sound
4. Which one of the following has maximum absorption coefficient.  
(a) marble   (b) carpet   (c) human body   (d) glass [     ]
5. Which one of the following has minimum absorption coefficient.[     ]  
(a) glass      (b) felt      (c) open window   (d) wooden floor
6. Diameter of one carbon atom is [     ]  
(a) 0.5nm   (b) 0.05 nm   (c) 0.15 nm   (d) 5 nm
7. In nanomaterials with decrease of size the interatomic spacing  
(a) Increase                      (b) Decreases [     ]  
(c) remains constant                      (d) first increase and then decrease
8. In nanomaterials with decrease of size, the melting point  
(a) Increase                      (b) remains constant [     ]  
(b) Decreases                      (d) first decrease and then increase
9. Gold nanospheres of 100nm appear [     ]  
(a) red in colour                      (b) blue in colour  
(c) orange in colour                      (d) violet in colour
10. Young's modulus value of single walled nanotubes is about [     ]  
(a) 1 Kilopascal                      (b) 1 Millipascal  
(c) 1 Terapascal                      (d) 1 Gigapascal

### Fill in the blanks

11. The unit of absorption coefficient is \_\_\_\_\_-.

12. The audible sounds have a frequency range \_\_\_\_ Hz to \_\_\_\_ Hz.
13. Eyring formula for reverberation time T is \_\_\_\_\_.
14. The unit of sound noise is \_\_\_\_\_.
15. The total absorption in a room is expressed in \_\_\_\_\_.
16. Fabric panels in a hall reflecting walls, cause \_\_\_\_\_ in a hall.
17. Nano materials are catalysts, because their enhanced \_\_\_\_ activity.
18. Aerogel is \_\_\_\_\_ nano crystalline.
19. Quantum dots are \_\_\_\_\_ materials.
20. The lifetime of a satellites increase by using \_\_\_\_\_ materials.

## Unit-V: Semiconductor Physics, Physics of Semiconductor Devices

### I. Fill in the blanks.

- In semiconductors, the valence band is..... and the Conduction band is ..... at low temperatures.
- The conductivity of p- type silicon is  $4 \text{ ohm}^{-1}$ , the mobility of holes is  $0.05 \text{ m}^2/\text{V-S}$ . Then the density of impurities is (atoms /  $\text{m}^3$ ) .....
- Fermi energy is the ..... energy that can be possessed by an electron at 0 K
- When forward biased, the forward current increases ..... with forward bias.
- The concentration of charge carriers in an intrinsic semiconductor is proportional to .....
- p-n junction diode, when forward biased behaves like a .....
- The mobility of electron is ..... than that of a hole.
- In an intrinsic semiconductor at a temperature T, the product electron and hole densities is given by the relation ....., where  $E_g$ , is the forbidden gap, and A, is a constant.
- The position of the Fermi- level in an impurity doped semiconductor depend on .... and the concentration of .....
- The diffusion hole current ( $J_p$ ) in a semiconductor is proportional to the .....

### II. Choose correct one

- At 0K pure silicon is
 

(a) an intrinsic semiconductor	(b) extrinsic semiconductor
(c) insulator	(d) superconductor.
- the majority carriers in p- type Ge are
 

(a) free electrons	(b) holes
(c) ions	(d) conduction electrons
- The electric current in a pure semiconductor when voltage is applied is due to
 

(a) electrons	(b) holes
(c) ions	(d) holes and electrons

14. In an intrinsic semiconductor at 0 K, the Fermi level lies
- (a) at the centre of top of the valence band and bottom of the conduction band
  - (b) at the centre of donor level and intrinsic Fermi level
  - (c) at the centre of donor level and bottom of the conduction band
  - (d) at the centre of acceptor level and top of the valence band
15. The density of charge carriers in a pure semiconductor is proportional to
- (a)  $\exp(-E_g / kT)$
  - (b)  $\exp(-2E_g / kT)$
  - (c)  $\exp(-E_g / kT^2)$
  - (d)  $\exp(-E_g / 2kT)$
16. The thickness of depletion region is in the order of
- (a)  $6 \times 10^{-3}$  cm
  - (b)  $6 \times 10^{-9}$  cm
  - (c)  $6 \times 10^{-6}$  cm
  - (d)  $6 \times 10^{-12}$  cm
17. In a LED, if  $E_g$  is the band gap, the wavelength of emission is given by
- (a)  $\lambda = E_g / h\nu$
  - (b)  $\lambda = h\nu / E_g$
  - (c)  $\lambda = E_g / hc$
  - (d)  $\lambda = hc / E_g$
18. Response time of LEDs in the order of
- (a)  $10^{-3}$  s
  - (b)  $10^{-6}$  s
  - (c)  $10^{-9}$  s
  - (d)  $10^{-12}$  s
19. Life time of LEDs is about
- (a)  $10^2$  hours
  - (b)  $10^3$  hours
  - (c)  $10^4$  hours
  - (d)  $10^5$  hours
20. LCD stands for
- (a) light cavity display
  - (b) light control display
  - (c) liquid crystal diode
  - (d) liquid crystal display

**JAWAHARLAL NEHRU TECHNOLOGICAL UNIVERSITY HYDERABAD**  
**I B.Tech. I Mid Examinations, November – 2009**  
**ENGINEERING PHYSICS**

**Objective Exam**

**Name:** \_\_\_\_\_ **Hall Ticket No. A**

**Answer All Questions. All Questions Carry Equal Marks. Time: 20 Min. Marks:**

**10.**

**I. Choose the correct alternative:**

1. The atomic packing factor of a simple cubic structure, is [ ]  
(a) 68% (b) 74% (c) 52% (d) 24%
2. The crystal planes (1 1 2) and (2 2 4) are [ ]  
(a) perpendicular to each other (b) intersecting at an angle other than 90°  
(c) parallel to each other (d) intersecting at an angle 45°
3. The Laue spots close to the centre of the Laue photograph correspond to [ ]  
(a) high Bragg angles (b) low Bragg angles  
(c) lesser interplanar separation of the crystal (d) larger wavelength of X-rays
4. NaCl crystal possess [ ]  
(a) FCC structure (b) HPC structure (c) SC structure (d) BCC structure
5. The diffraction of X-rays by crystal planes [ ]  
(a) reveals the nature of X-rays  
(b) helps to know the characteristics of X-rays  
(c) reveals the internal arrangement of atoms in the crystal  
(d) helps to know the properties of the crystals
6. Burger's vector gives [ ]  
(a) length of Burger's circuit (b) magnitude and direction of dislocation  
(c) magnitude and direction of point defect (d) magnitude and direction of surface defect
7. The amount of energy required to separate the atoms completely [ ]  
from the structure, is called  
(a) cohesive energy (b) potential energy (c) attractive energy (d) repulsive energy
8. The number of atoms belonging to a unit cell is one, for [ ]  
(a) body centered cubic structure (b) face centered cubic structure  
(c) base centered cubic structure (d) simple cubic structure
9. CsCl crystal possess [ ]  
(a) FCC structure (b) HPC structure (c) SC structure (d) BCC structure
10. Twin boundary in a crystal, is called [ ]  
(a) zero dimensional defect (b) one dimensional defect  
(c) two dimensional defect (d) three dimensional defect

**Cont.....2**

**Set No. 1****II. Fill in the Blanks:**

11. KBr is an example for \_\_\_\_\_ bond.
12. The number of basic crystal systems, is \_\_\_\_\_
13. The number of atoms belonging to the unit cell of BCC structure, is \_\_\_\_\_.
14. The number of Frenkel defects increase exponentially with \_\_\_\_\_ of temperature.
15. In an \_\_\_\_\_ crystal system  $a \neq b \neq c$  and  $\alpha = \beta = 90^\circ \neq \gamma$
16. The angle at which reflection is maximum in X-ray diffraction by crystal planes, is called \_\_\_\_\_ angle.
17. In the powder method of X-ray diffraction, the camera used is \_\_\_\_\_ camera.
18. In ionic crystals, an ion displaced from a regular site to an interstitial site, is called \_\_\_\_\_ imperfection.
19. Silver is an example for \_\_\_\_\_ bond.
20. The Miller Indices of the plane parallel to Y and Z axes are \_\_\_\_\_

-oOo-



Set No. 2

JAWAHARLAL NEHRU TECHNOLOGICAL UNIVERSITY HYDERABAD  
I B.Tech. I Mid Examinations, November – 2009  
ENGINEERING PHYSICS

Objective Exam

Name: \_\_\_\_\_ Hall Ticket No. \_\_\_\_\_

Answer All Questions. All Questions Carry Equal Marks. Time: 20 Min. Marks: 10.

I. Choose the correct alternative:

1. NaCl crystal possess [ ]  
(a) FCC structure (b) HPC structure (c) SC structure (d) BCC structure
2. The diffraction of X-rays by crystal planes [ ]  
(a) reveals the nature of X-rays  
(b) helps to know the characteristics of X-rays  
(c) reveals the internal arrangement of atoms in the crystal  
(d) helps to know the properties of the crystals
3. Burger's vector gives [ ]  
(a) length of Burger's circuit (b) magnitude and direction of dislocation  
(c) magnitude and direction of point defect (d) magnitude and direction of surface defect
4. The amount of energy required to separate the atoms completely [ ]  
from the structure, is called  
(a) cohesive energy (b) potential energy (c) attractive energy (d) repulsive energy
5. The number of atoms belonging to a unit cell is one, for [ ]  
(a) body centered cubic structure (b) face centered cubic structure  
(c) base centered cubic structure (d) simple cubic structure
6. CsCl crystal possess [ ]  
(a) FCC structure (b) HPC structure (c) SC structure (d) BCC structure
7. Twin boundary in a crystal, is called [ ]  
(a) zero dimensional defect (b) one dimensional defect  
(c) two dimensional defect (d) three dimensional defect
8. The atomic packing factor of a simple cubic structure, is [ ]  
(a) 68% (b) 74% (c) 52% (d) 24%
9. The crystal planes (1 1 2) and (2 2 4) are [ ]  
(a) perpendicular to each other (b) intersecting at an angle other than 90°  
(c) parallel to each other (d) intersecting at an angle 45°
10. The Laue spots close to the centre of the Laue photograph correspond to [ ]  
(a) high Bragg angles (b) low Bragg angles  
(c) lesser interplanar separation of the crystal (d) larger wavelength of X-rays

Cont.....2

Set No. 2

**II. Fill in the Blanks:**

11. The number of Frenkel defects increase exponentially with \_\_\_\_\_ of temperature.

12. In an \_\_\_\_\_ crystal system  $a \neq b \neq c$  and  $\alpha = \beta = \gamma = 90^\circ$ .

13. The angle at which reflection is maximum in X-ray diffraction by crystal planes, is called \_\_\_\_\_ angle.

14. In the powder method of X-ray diffraction, the camera used is \_\_\_\_\_ camera.

15. In ionic crystals, an ion displaced from a regular site to an interstitial site, is called \_\_\_\_\_ imperfection.

16. Silver is an example for \_\_\_\_\_ bond.

17. The Miller Indices of the plane parallel to Y and Z axes are \_\_\_\_\_.

18. KBr is an example for \_\_\_\_\_ bond.

19. The number of basic crystal systems, is \_\_\_\_\_.

20. The number of atoms belonging to the unit cell of BCC structure, is \_\_\_\_\_.

-oOo-

Set No. 3

**JAWAHARLAL NEHRU TECHNOLOGICAL UNIVERSITY HYDERABAD**  
**I B.Tech. I Mid Examinations, November – 2009**  
**ENGINEERING PHYSICS**

**Objective Exam**

**Name:** \_\_\_\_\_ **Hall Ticket No.** \_\_\_\_\_

**Answer All Questions. All Questions Carry Equal Marks. Time: 20 Min. Marks: 10.**

**I. Choose the correct alternative:**

1. Burger's vector gives [ ]  
(a) length of Burger's circuit (b) magnitude and direction of dislocation  
(c) magnitude and direction of point defect (d) magnitude and direction of surface defect
2. The amount of energy required to separate the atoms completely [ ]  
from the structure, is called  
(a) cohesive energy (b) potential energy (c) attractive energy (d) repulsive energy
3. The number of atoms belonging to a unit cell is one, for [ ]  
(a) body centered cubic structure (b) face centered cubic structure  
(c) base centered cubic structure (d) simple cubic structure
4. CsCl crystal possess [ ]  
(a) FCC structure (b) HPC structure (c) SC structure (d) BCC structure
5. Twin boundary in a crystal, is called [ ]  
(a) zero dimensional defect (b) one dimensional defect  
(c) two dimensional defect (d) three dimensional defect
6. The atomic packing factor of a simple cubic structure, is [ ]  
(a) 68% (b) 74% (c) 52% (d) 24%
7. The crystal planes (1 1 2) and (2 2 4) are [ ]  
(a) perpendicular to each other (b) intersecting at an angle other than 90°  
(c) parallel to each other (d) intersecting at an angle 45°
8. The Laue spots close to the centre of the Laue photograph correspond to [ ]  
(a) high Bragg angles (b) low Bragg angles  
(c) lesser interplanar separation of the crystal (d) larger wavelength of X-rays
9. NaCl crystal possess [ ]  
(a) FCC structure (b) HPC structure (c) SC structure (d) BCC structure
10. The diffraction of X-rays by crystal planes [ ]  
(a) reveals the nature of X-rays  
(b) helps to know the characteristics of X-rays  
(c) reveals the internal arrangement of atoms in the crystal

(d) helps to know the properties of the crystals

**Set No. 3**

**II. Fill in the Blanks:**

11. The angle at which reflection is maximum in X-ray diffraction by crystal planes, is called \_\_\_\_\_ angle.
12. In the powder method of X-ray diffraction, the camera used is \_\_\_\_\_ camera.
13. In ionic crystals, an ion displaced from a regular site to an interstitial site, is called \_\_\_\_\_ imperfection.
14. Silver is an example for \_\_\_\_\_ bond.
15. The Miller Indices of the plane parallel to Y and Z axes are \_\_\_\_\_.
16. KBr is an example for \_\_\_\_\_ bond.
17. The number of basic crystal systems, is \_\_\_\_\_.
18. The number of atoms belonging to the unit cell of BCC structure, is \_\_\_\_\_.
19. The number of Frenkel defects increase exponentially with \_\_\_\_\_ of temperature.
20. In an \_\_\_\_\_ crystal system  $a \neq b \neq c$  and  $\alpha = \beta = \gamma = 90^\circ$ .

-oOo-

Set No. 4

**JAWAHARLAL NEHRU TECHNOLOGICAL UNIVERSITY HYDERABAD**  
**I B.Tech. I Mid Examinations, November – 2009**  
**ENGINEERING PHYSICS**

**Objective Exam**

**Name:** \_\_\_\_\_ **Hall Ticket No. A**

**Answer All Questions. All Questions Carry Equal Marks. Time: 20 Min. Marks: 10.**

**I. Choose the correct alternative:**

- The number of atoms belonging to a unit cell is one, for [ ]  
(a) body centered cubic structure (b) face centered cubic structure  
(c) base centered cubic structure (d) simple cubic structure
- CsCl crystal possess [ ]  
(a) FCC structure (b) HPC structure (c) SC structure (d) BCC structure
- Twin boundary in a crystal, is called [ ]  
(a) zero dimensional defect (b) one dimensional defect  
(c) two dimensional defect (d) three dimensional defect
- The atomic packing factor of a simple cubic structure, is [ ]  
(a) 68% (b) 74% (c) 52% (d) 24%
- The crystal planes (1 1 2) and (2 2 4) are [ ]  
(a) perpendicular to each other (b) intersecting at an angle other than 90°  
(c) parallel to each other (d) intersecting at an angle 45°
- The Laue spots close to the centre of the Laue photograph correspond to [ ]  
(a) high Bragg angles (b) low Bragg angles  
(c) lesser interplanar separation of the crystal (d) larger wavelength of X-rays
- NaCl crystal possess [ ]  
(a) FCC structure (b) HPC structure (c) SC structure (d) BCC structure
- The diffraction of X-rays by crystal planes [ ]  
(a) reveals the nature of X-rays  
(b) helps to know the characteristics of X-rays  
(c) reveals the internal arrangement of atoms in the crystal  
(d) helps to know the properties of the crystals
- Burger's vector gives [ ]  
(a) length of Burger's circuit (b) magnitude and direction of dislocation  
(c) magnitude and direction of point defect (d) magnitude and direction of surface defect
- The amount of energy required to separate the atoms completely [ ]  
from the structure, is called  
(a) cohesive energy (b) potential energy (c) attractive energy (d) repulsive energy

**Set No. 4****II. Fill in the Blanks:**

11. In ionic crystals, an ion displaced from a regular site to an interstitial site, is called \_\_\_\_\_  
imperfection.
12. Silver is an example for \_\_\_\_\_ bond.
13. The Miller Indices of the plane parallel to Y and Z axes are \_\_\_\_\_
14. KBr is an example for \_\_\_\_\_ bond.
15. The number of basic crystal systems, is \_\_\_\_\_
16. The number of atoms belonging to the unit cell of BCC structure, is \_\_\_\_\_.
17. The number of Frenkel defects increase exponentially with \_\_\_\_\_ of temperature.
18. In an \_\_\_\_\_ crystal system  $a \neq b \neq c$  and  $\alpha = \beta = \gamma = 90^\circ$ .
19. The angle at which reflection is maximum in X-ray diffraction by crystal planes, is called \_\_\_\_\_ angle.
20. In the powder method of X-ray diffraction, the camera used is \_\_\_\_\_ camera.

-oOo-

**Code No: 09A1BS02 Set No. 1**  
**JAWAHARLAL NEHRU TECHNOLOGICAL UNIVERSITY HYDERABAD**  
**I B.Tech. II Mid Examinations, March – 2010**  
**ENGINEERING PHYSICS**

**Objective Exam**

Name: \_\_\_\_\_ Hall Ticket No. \_\_\_\_\_

**Answer All Questions. All Questions Carry Equal Marks. Time: 20 Min. Marks: 10.****I. Choose the correct alternative:**

1. The Maxwell-Boltzmann statistics deals with particles having [ ]  
(A) integral spin (B) half integral spin  
(C) no spin (D) any value of spin
  
2. According to Planck's quantum theory of radiation [ ]  
(A) energy is emitted in the form of waves  
(B) energy is emitted in the form of mechanical waves  
(C) energy is emitted in the form of a continuous stream  
(D) energy is emitted in the form of packets called photons
  
3. If  $E_1$  is the energy value for the ground state of an electron in a one-dimensional potential well of length  $L$ , the energy of the first excited state is equal to [ ]  
(A)  $E_1$  (B)  $2 E_1$  (C)  $4 E_1$  (D)  $9 E_1$
  
4. The zone theory of electrons was developed by [ ]  
(A) Sommerfeld (B) Planck  
(C) Drude and Lorentz (D) Bloch
  
5. In an allowed energy band, the velocity of an electron is zero, at [ ]  
(A) top of the band (B) any where in the band  
(C) top and bottom of the band (D) bottom of the band
  
6. An example for direct band gap semiconductor is [ ]  
(A) Ge (B) GaAs (C) Si (D) SiO
  
7. If the Hall coefficient is negative, then the semiconductor is [ ]  
(A) intrinsic (B) p-type (C) n-type (D) extrinsic
  
8. The Fermi level of intrinsic semiconductor raises slightly with increase of temperature, because [ ]  
(A) the effective mass of electron is greater than the effective mass hole  
(B) the mass of hole is greater than the mass electron  
(C) the effective mass of hole is greater than the effective mass electron  
(D) the mass of electron is greater than the mass hole
  
9. Application of forward bias to a junction diode reduces [ ]  
(A) the minority carrier current to zero (B) the majority carrier current to zero  
(C) the potential barrier (D) the current to zero
  
10. Infra-red LED finds application in [ ]  
(A) test instruments (B) burglar's alarm  
(C) pocket calculators (D) display boards

**II Fill in the Blanks**

11. The number of quantum states present in a metal between the energies  $E$  and  $E+dE$  per unit volume is called \_\_\_\_\_
12. In the spectrum of black body radiation, the wavelength maximum \_\_\_\_\_ with increase in temperature.
13. When a potential difference of 400 volts is applied in accelerating an electron, the wavelength attained by the electron, is \_\_\_\_\_ A.U.
14. One-dimensional time-independent Schrodinger's wave equation is \_\_\_\_\_
15. Pure semiconductor behaves as an insulator at \_\_\_\_\_ K
16. The electrons in a periodic potential move with \_\_\_\_\_ mass.
17. For Ge at room temperature, the intrinsic concentration is  $2.5 \times 10^{13} \text{ cm}^{-3}$ . The donor impurity concentration is  $5 \times 10^{15} \text{ cm}^{-3}$ . Then the hole concentration in the semiconductor is \_\_\_\_\_  $\text{cm}^{-3}$ .
18. Under equilibrium conditions, the rate of generation of holes in a semiconductor, is equal to the rate of loss due to recombination. The equation relating the generation rate and loss rate is known as \_\_\_\_\_
19. The recombination produces a layer, at P-N junction, is called \_\_\_\_\_
20. The rectification efficiency of a half-wave rectifier is \_\_\_\_\_.

-oOo-



**Code No: 09A1BS02 Set No. 2**  
**JAWAHARLAL NEHRU TECHNOLOGICAL UNIVERSITY HYDERABAD**  
**I B.Tech. II Mid Examinations, March – 2010**  
**ENGINEERING PHYSICS**

**Objective Exam**

**Name:** \_\_\_\_\_ **Hall Ticket No.** \_\_\_\_\_

**Answer All Questions. All Questions Carry Equal Marks. Time: 20 Min. Marks: 10.**

**I. Choose the correct alternative:**

1. The zone theory of electrons was developed by [ ]  
 (A) Sommerfeld (B) Planck (C) Drude and Lorentz (D) Bloch
2. In an allowed energy band, the velocity of an electron is zero, at [ ]  
 (A) top of the band (B) any where in the band  
 (C) top and bottom of the band (D) bottom of the band
3. An example for direct band gap semiconductor is [ ]  
 (A) Ge (B) GaAs (C) Si (D) SiO
4. If the Hall coefficient is negative, then the semiconductor is [ ]  
 (A) intrinsic (B) p-type (C) n-type (D) extrinsic
5. The Fermi level of intrinsic semiconductor raises slightly with increase of temperature, because  
 [ ]  
 (A) the effect mass of electron is greater than the effective mass hole  
 (B) the mass of hole is greater than the mass electron  
 (C) the effect mass of hole is greater than the effective mass electron  
 (D) the mass of electron is greater than the mass hole
6. Application of forward bias to a junction diode reduces [ ]  
 (A) the minority carrier current to zero (B) the majority carrier current to zero  
 (C) the potential barrier (D) the current to zero
7. Infra-red LED finds application in [ ]  
 (A) test instruments (B) burglar's alarm (C) pocket calculators (D) display boards
8. The Maxwell-Boltzmann statistics deals with particles having [ ]  
 (A) integral spin (B) half integral spin (C) no spin (D) any value of spin
9. According to Planck's quantum theory of radiation [ ]  
 (A) energy is emitted in the form of waves  
 (B) energy is emitted in the form of mechanical waves  
 (C) energy is emitted in the form of a continuous stream  
 (D) energy is emitted in the form of packets called photons

**Cont...2**

**Code No: 09A1BS02 :2: Set No. 2**

10. If  $E_1$  is the energy value for the ground state of an electron in a one-dimensional potential well of length  $L$ , the energy of the first excited state is equal to [ ]  
 (A)  $E_1$  (B)  $2 E_1$  (C)  $4 E_1$  (D)  $9 E_1$

**II Fill in the Blanks**

11. One-dimensional time-independent Schrodinger's wave equation is \_\_\_\_\_
12. Pure semiconductor behaves as an insulator at \_\_\_\_\_ K
13. The electrons in a periodic potential move with \_\_\_\_\_ mass.
14. For Ge at room temperature, the intrinsic concentration is  $2.5 \times 10^{13} \text{ cm}^{-3}$ . The donor impurity concentration is  $5 \times 10^{15} \text{ cm}^{-3}$ . Then the hole concentration in the semiconductor is \_\_\_\_\_  $\text{cm}^{-3}$ .

15. Under equilibrium conditions, the rate of generation of holes in a semiconductor, is equal to the rate of loss due to recombination. The equation relating the generation rate and loss rate is known as \_\_\_\_\_
16. The recombination produces a layer, at P-N junction, is called \_\_\_\_\_
17. The rectification efficiency of a half-wave rectifier is \_\_\_\_\_.
18. The number of quantum states present in a metal between the energies  $E$  and  $E+dE$  per unit volume is called \_\_\_\_\_
19. In the spectrum of black body radiation, the wavelength maximum \_\_\_\_\_ with increase in temperature.
20. When a potential difference of 400 volts is applied in accelerating an electron, the wavelength attained by the electron, is \_\_\_\_\_ A.U.

-oOo-

**Code No: 09A1BS02 Set No. 3**  
**JAWAHARLAL NEHRU TECHNOLOGICAL UNIVERSITY HYDERABAD**  
**I B.Tech. II Mid Examinations, March – 2010**  
**ENGINEERING PHYSICS**

**Objective Exam**

**Name:** \_\_\_\_\_ **Hall Ticket No. A**

**Answer All Questions. All Questions Carry Equal Marks. Time: 20 Min. Marks: 10.**

**I. Choose the correct alternative:**

- 1 An example for direct band gap semiconductor is [ ]  
 (A) Ge (B) GaAs (C) Si (D) SiO
- 2 If the Hall coefficient is negative, then the semiconductor is [ ]  
 (A) intrinsic (B) p-type (C) n-type (D) extrinsic
- 3 The Fermi level of intrinsic semiconductor raises slightly with increase of temperature, because  
 [ ]  
 (A) the effective mass of electron is greater than the effective mass hole  
 (B) the mass of hole is greater than the mass electron  
 (C) the effective mass of hole is greater than the effective mass electron  
 (D) the mass of electron is greater than the mass hole
- 4 Application of forward bias to a junction diode reduces [ ]  
 (A) the minority carrier current to zero (B) the majority carrier current to zero  
 (C) the potential barrier (D) the current to zero
- 5 Infra-red LED finds application in [ ]  
 (A) test instruments (B) burglar's alarm (C) pocket calculators (D) display boards
- 6 The Maxwell-Boltzmann statistics deals with particles having [ ]  
 (A) integral spin (B) half integral spin  
 (C) no spin (D) any value of spin
- 7 According to Planck's quantum theory of radiation [ ]  
 (A) energy is emitted in the form of waves  
 (B) energy is emitted in the form of mechanical waves  
 (C) energy is emitted in the form of a continuous stream  
 (D) energy is emitted in the form of packets called photons
- 8 If  $E_1$  is the energy value for the ground state of an electron in a one-dimensional potential well of length  $L$ , the energy of the first excited state is equal to [ ]  
 (A)  $E_1$  (B)  $2 E_1$  (C)  $4 E_1$  (D)  $9 E_1$
9. The zone theory of electrons was developed by [ ]  
 (A) Sommerfeld (B) Planck (C) Drude and Lorentz (D) Bloch

**Cont....2**

**Code No: 09A1BS02 :2: Set No. 3**

10. In an allowed energy band, the velocity of an electron is zero, at [ ]  
 (A) top of the band (B) any where in the band  
 (C) top and bottom of the band (D) bottom of the band

**II Fill in the Blanks**

11. The electrons in a periodic potential move with \_\_\_\_\_ mass.
12. For Ge at room temperature, the intrinsic concentration is  $2.5 \times 10^{13} \text{ cm}^{-3}$ . The donor impurity concentration is  $5 \times 10^{15} \text{ cm}^{-3}$ . Then the hole concentration in the semiconductor is \_\_\_\_\_  $\text{cm}^{-3}$ .
13. Under equilibrium conditions, the rate of generation of holes in a semiconductor, is equal to the

rate of loss due to recombination. The equation relating the generation rate and loss rate is known

as \_\_\_\_\_

14. The recombination produces a layer, at P-N junction, is called \_\_\_\_\_

15. The rectification efficiency of a half-wave rectifier is \_\_\_\_\_.

16. The number of quantum states present in a metal between the energies  $E$  and  $E+dE$  per unit volume

is called \_\_\_\_\_

17. In the spectrum of black body radiation, the wavelength maximum \_\_\_\_\_ with increase in temperature.

18. When a potential difference of 400 volts is applied in accelerating an electron, the wavelength

attained by the electron, is \_\_\_\_\_ A.U.

19. One-dimensional time-independent Schrodinger's wave equation is \_\_\_\_\_

20. Pure semiconductor behaves as an insulator at \_\_\_\_\_ K

-oOo-

**Code No: 09A1BS02 Set No. 4**  
**JAWAHARLAL NEHRU TECHNOLOGICAL UNIVERSITY HYDERABAD**  
**I B.Tech. II Mid Examinations, March – 2010**  
**ENGINEERING PHYSICS**

**Objective Exam**

**Name:** \_\_\_\_\_ **Hall Ticket No. A**

**Answer All Questions. All Questions Carry Equal Marks. Time: 20 Min. Marks: 10.**

**I. Choose the correct alternative:**

1. The Fermi level of intrinsic semiconductor raises slightly with increase of temperature, because  
  
 (A) the effect mass of electron is greater than the effective mass hole  
 (B) the mass of hole is greater than the mass electron  
 (C) the effect mass of hole is greater than the effective mass electron  
 (D) the mass of electron is greater than the mass hole
2. Application of forward bias to a junction diode reduces   
 (A) the minority carrier current to zero (B) the majority carrier current to zero  
 (C) the potential barrier (D) the current to zero
3. Infra-red LED finds application in   
 (A) test instruments (B) burglar's alarm  
 (C) pocket calculators (D) display boards
4. The Maxwell-Boltzmann statistics deals with particles having   
 (A) integral spin (B) half integral spin  
 (C) no spin (D) any value of spin
5. According to Planck's quantum theory of radiation   
 (A) energy is emitted in the form of waves  
 (B) energy is emitted in the form of mechanical waves  
 (C) energy is emitted in the form of a continuous stream  
 (D) energy is emitted in the form of packets called photons
6. If  $E_1$  is the energy value for the ground state of an electron in a one-dimensional potential well of length  $L$ , the energy of the first excited state is equal to   
 (A)  $E_1$  (B)  $2 E_1$  (C)  $4 E_1$  (D)  $9 E_1$
7. The zone theory of electrons was developed by   
 (A) Sommerfeld (B) Planck  
 (C) Drude and Lorentz (D) Bloch
8. In an allowed energy band, the velocity of an electron is zero, at   
 (A) top of the band (B) any where in the band  
 (C) top and bottom of the band (D) bottom of the band

**Cont..2**

**Code No: 09A1BS02 :2: Set No. 4**

9. An example for direct band gap semiconductor is   
 (A) Ge (B) GaAs (C) Si (D) SiO
10. If the Hall coefficient is negative, then the semiconductor is   
 (A) intrinsic (B) p-type (C) n-type (D) extrinsic

**II Fill in the Blanks**

11. Under equilibrium conditions, the rate of generation of holes in a semiconductor, is equal to the rate of loss due to recombination. The equation relating the generation rate and loss rate is known as \_\_\_\_\_

12. The recombination produces a layer, at P-N junction, is called \_\_\_\_\_
13. The rectification efficiency of a half-wave rectifier is \_\_\_\_\_.
14. The number of quantum states present in a metal between the energies  $E$  and  $E+dE$  per unit volume is called \_\_\_\_\_
15. In the spectrum of black body radiation, the wavelength maximum \_\_\_\_\_ with increase in temperature.
16. When a potential difference of 400 volts is applied in accelerating an electron, the wavelength attained by the electron, is \_\_\_\_\_ A.U.
17. One-dimensional time-independent Schrodinger's wave equation is \_\_\_\_\_
18. Pure semiconductor behaves as an insulator at \_\_\_\_\_ K
19. The electrons in a periodic potential move with \_\_\_\_\_ mass.
20. For Ge at room temperature, the intrinsic concentration is  $2.5 \times 10^{13} \text{ cm}^{-3}$ . The donor impurity concentration is  $5 \times 10^{15} \text{ cm}^{-3}$ . Then the hole concentration in the semiconductor is \_\_\_\_\_  $\text{cm}^{-3}$ .

-oOo-

**Code No: A109100104 Set No. 1**  
**JAWAHARLAL NEHRU TECHNOLOGICAL UNIVERSITY HYDERABAD**  
**I B.Tech. III Mid Examinations, May- 2010**  
**ENGINEERING PHYSICS**

**Objective Exam**

**Name:** \_\_\_\_\_ **Hall Ticket No. A**

**Answer All Questions. All Questions Carry Equal Marks. Time: 20 Min. Marks: 10.**

**I. Choose the correct alternative:**

1. The material in which spontaneous polarization changes with temperature, is called [ ]  
 (A) ferroelectric (B) pyroelectric (C) piezoelectric (D) anti-ferromagnetic
2. Nickel zinc ferrites are used as cores in [ ]  
 (A) radios (B) TV transformers (C) transmitters (D) electromagnets
3. In multimode graded index fiber, light rays travel in different parts of the fiber [ ]  
 (A) with different speeds (B) with same speed  
 (C) with minimum speed (D) with maximum speed
4. In fiber optic communication system, the preferable source of light is [ ]  
 (A) LED (B) sodium lamp (C) mercury lamp (D) laser
5. The residential soundproofing aims to eliminate the effects of [ ]  
 (A) internal noise (B) reverberation (C) absorption (D) external noise
6. The magnetic susceptibility ( $\div$ ) of a magnetic material is given by [ ]  
 (A)  $\div = (i_r - 1)$  (B)  $\div = (i_r + 1)$  (C)  $\div = (1 - i_r)$  (D)  $\div = (i_o - 1)$
7. The condition for lasing action is [ ]  
 (A) excitation (B) meta-stable state (C) population inversion (D) emission
8. The reverberation time for an auditorium is the time required for the intensity of sound to drop to  
 [ ]  
 (A)  $10^{-9}$  times its initial value (B)  $10^{-6}$  times its initial value  
 (C)  $10^{-3}$  times its initial value (D)  $10^{-8}$  times its initial value
9. Which of the following is not a stage of sol-gel formation? [ ]  
 (A) Agglomeration (B) Condensation (C) Hydrolysis (D) Sputtering
10. The relation between magnetic induction (B), magnetic field strength (H) and magnetization (M) is  
 [ ]  
 a.  $B = H + M$  (B)  $B = M + i_o H$  (C)  $B = i_o (H + M)$  (D)  $M = B + i_o H$   
 b.

**II Fill in the blanks**

11. The unit for measurement of displacement vector is \_\_\_\_\_.
12. Above Curie temperature, the shape of B-H curve of a ferromagnetic material is in the form of a \_\_\_\_\_.
13. The phenomenon of expulsion of magnetic lines from a super-conductor is known as \_\_\_\_\_.
14. The unit of Einstein's coefficient is \_\_\_\_\_.
15. The synthesizing of nanomaterials from larger pieces of material, is called \_\_\_\_\_ technique.
16. Ionic Polarization is \_\_\_\_\_ temperature.
17. The active element in ruby laser is \_\_\_\_\_.
18. The acceptance angle of a fiber of numerical aperture 0.22, is \_\_\_\_\_°.
19. A \_\_\_\_\_ is a device for reducing the amount of noise emitted by a machine.

20. When the radius of a sphere is reduced to 2.0 nm, the surface area to volume ratio becomes

\_\_\_\_\_ per meter.

-oOo-

JNTUWorld



**Code No: A109100104 Set No. 2**  
**JAWAHARLAL NEHRU TECHNOLOGICAL UNIVERSITY HYDERABAD**  
**I B.Tech. III Mid Examinations, May – 2010**  
**ENGINEERING PHYSICS**

**Objective Exam**

Name: \_\_\_\_\_ Hall Ticket No. A

**Answer All Questions. All Questions Carry Equal Marks. Time: 20 Min. Marks: 10.**

**I. Choose the correct alternative:**

1. In fiber optic communication system, the preferable source of light is [ ]  
 (A) LED (B) sodium lamp (C) mercury lamp (D) laser
2. The residential soundproofing aims to eliminate the effects of [ ]  
 (A) internal noise (B) reverberation (C) absorption (D) external noise
3. The magnetic susceptibility ( $\div$ ) of a magnetic material is given by [ ]  
 (A)  $\div = (\mu_r - 1)$  (B)  $\div = (\mu_r + 1)$  (C)  $\div = (1 - \mu_r)$  (D)  $\div = (\mu_0 - 1)$
4. The condition for lasing action is [ ]  
 (A) excitation (B) meta-stable state (C) population inversion (D) emission
5. The reverberation time for an auditorium is the time required for the intensity of sound to drop to [ ]  
 (A)  $10^{-9}$  times its initial value (B)  $10^{-6}$  times its initial value  
 (C)  $10^{-3}$  times its initial value (D)  $10^{-8}$  times its initial value
6. Which of the following is not a stage of sol-gel formation? [ ]  
 (A) Agglomeration (B) Condensation (C) Hydrolysis (D) Sputtering
7. The relation between magnetic induction (B), magnetic field strength (H) and magnetization (M) is [ ]  
 (A)  $B = H + M$  (B)  $B = M + \mu_0 H$  (C)  $B = \mu_0 (H + M)$  (D)  $M = B + \mu_0 H$
8. The material in which spontaneous polarization changes with temperature, is called [ ]  
 (A) ferroelectric (B) pyroelectric (C) piezoelectric (D) anti-ferromagnetic
9. Nickel zinc ferrites are used as cores in [ ]  
 (A) radios (B) TV transformers (C) transmitters (D) electromagnets
10. In multimode graded index fiber, light rays travel in different parts of the fiber [ ]  
 (A) with different speeds (B) with same speed  
 (C) with minimum speed (D) with maximum speed

**II Fill in the blanks**

11. The unit of Einstein's coefficient is \_\_\_\_\_.
12. The synthesizing of nanomaterials from larger pieces of material, is called \_\_\_\_\_ technique.
13. Ionic Polarization is \_\_\_\_\_ temperature.
14. The active element in ruby laser is \_\_\_\_\_.
15. The acceptance angle of a fiber of numerical aperture 0.22, is \_\_\_\_\_°.
16. A \_\_\_\_\_ is a device for reducing the amount of noise emitted by a machine.
17. When the radius of a sphere is reduced to 2.0 nm, the surface area to volume ratio becomes \_\_\_\_\_ per meter.
18. The unit for measurement of displacement vector is \_\_\_\_\_.
19. Above Curie temperature, the shape of B-H curve of a ferromagnetic material is in the form of a \_\_\_\_\_.

20. The phenomenon of expulsion of magnetic lines from a super-conductor is known as

\_\_\_\_\_.

-oOo-

JNTUWorld

**Code No: A109100104 Set No. 3**  
**JAWAHARLAL NEHRU TECHNOLOGICAL UNIVERSITY HYDERABAD**  
**I B.Tech. III Mid Examinations, May – 2010**  
**ENGINEERING PHYSICS**

**Objective Exam**

Name: \_\_\_\_\_ Hall Ticket No. A

**Answer All Questions. All Questions Carry Equal Marks. Time: 20 Min. Marks: 10.**

**I. Choose the correct alternative:**

1. The magnetic susceptibility ( $\chi$ ) of a magnetic material is given by [ ]  
 (A)  $\chi = (\mu_r - 1)$  (B)  $\chi = (\mu_r + 1)$  (C)  $\chi = (1 - \mu_r)$  (D)  $\chi = (\mu_0 - 1)$
2. The condition for lasing action is [ ]  
 (A) excitation (B) meta-stable state (C) population inversion (D) emission
3. The reverberation time for an auditorium is the time required for the intensity of sound to drop to  
 [ ]  
 (A)  $10^{-9}$  times its initial value (B)  $10^{-6}$  times its initial value  
 (C)  $10^{-3}$  times its initial value (D)  $10^{-8}$  times its initial value
4. Which of the following is not a stage of sol-gel formation? [ ]  
 (A) Agglomeration (B) Condensation (C) Hydrolysis (D) Sputtering
5. The relation between magnetic induction (B), magnetic field strength (H) and magnetization (M) is  
 [ ]  
 (A)  $B = H + M$  (B)  $B = M + \mu_0 H$  (C)  $B = \mu_0 (H + M)$  (D)  $M = B + \mu_0 H$
6. The material in which spontaneous polarization changes with temperature, is called [ ]  
 (A) ferroelectric (B) pyroelectric (C) piezoelectric (D) anti-ferromagnetic
7. Nickel zinc ferrites are used as cores in [ ]  
 (A) radios (B) TV transformers (C) transmitters (D) electromagnets
8. In multimode graded index fiber, light rays travel in different parts of the fiber [ ]  
 (A) with different speeds (B) with same speed  
 (C) with minimum speed (D) with maximum speed
9. In fiber optic communication system, the preferable source of light is [ ]  
 (A) LED (B) sodium lamp (C) mercury lamp (D) laser
10. The residential soundproofing aims to eliminate the effects of [ ]  
 (A) internal noise (B) reverberation (C) absorption (D) external noise

**II Fill in the blanks**

11. Ionic Polarization is \_\_\_\_\_ temperature.
12. The active element in ruby laser is \_\_\_\_\_.
13. The acceptance angle of a fiber of numerical aperture 0.22, is \_\_\_\_\_°.
14. A \_\_\_\_\_ is a device for reducing the amount of noise emitted by a machine.
15. When the radius of a sphere is reduced to 2.0 nm, the surface area to volume ratio becomes \_\_\_\_\_ per meter.
16. The unit for measurement of displacement vector is \_\_\_\_\_.
17. Above Curie temperature, the shape of B-H curve of a ferromagnetic material is in the form of a \_\_\_\_\_.
18. The phenomenon of expulsion of magnetic lines from a super-conductor is known as \_\_\_\_\_.

19. The unit of Einstein's coefficient is \_\_\_\_\_.
20. The synthesizing of nanomaterials from larger pieces of material, is called \_\_\_\_\_ technique.

-oOo-

JNTUWorld

**Code No: A109100104 Set No. 4**  
**JAWAHARLAL NEHRU TECHNOLOGICAL UNIVERSITY HYDERABAD**  
**I B.Tech. III Mid Examinations, May – 2010**  
**ENGINEERING PHYSICS**

**Objective Exam**

**Name:** \_\_\_\_\_ **Hall Ticket No. A**

**Answer All Questions. All Questions Carry Equal Marks. Time: 20 Min. Marks: 10.**

**I. Choose the correct alternative:**

1. The reverberation time for an auditorium is the time required for the intensity of sound to drop to

[ ]

(A)  $10^{-9}$  times its initial value (B)  $10^{-6}$  times its initial value

(C)  $10^{-3}$  times its initial value (D)  $10^{-8}$  times its initial value

2. Which of the following is not a stage of sol-gel formation? [ ]

(A) Agglomeration (B) Condensation (C) Hydrolysis (D) Sputtering

3. The relation between magnetic induction (B), magnetic field strength (H) and magnetization (M) is

[ ]

(A)  $B = H + M$  (B)  $B = M + \mu_0 H$  (C)  $B = \mu_0 (H + M)$  (D)  $M = B + \mu_0 H$

4. The material in which spontaneous polarization changes with temperature, is called [ ]

(A) ferroelectric (B) pyroelectric (C) piezoelectric (D) anti-ferromagnetic

5. Nickel zinc ferrites are used as cores in [ ]

(A) radios (B) TV transformers (C) transmitters (D) electromagnets

6. In multimode graded index fiber, light rays travel in different parts of the fiber [ ]

(A) with different speeds (B) with same speed

(C) with minimum speed (D) with maximum speed

7. In fiber optic communication system, the preferable source of light is [ ]

(A) LED (B) sodium lamp (C) mercury lamp (D) laser

8. The residential soundproofing aims to eliminate the effects of [ ]

(A) internal noise (B) reverberation (C) absorption (D) external noise

9. The magnetic susceptibility ( $\chi$ ) of a magnetic material is given by [ ]

(A)  $\chi = (\mu_r - 1)$  (B)  $\chi = (\mu_r + 1)$  (C)  $\chi = (1 - \mu_r)$  (D)  $\chi = (\mu_0 - 1)$

10. The condition for lasing action is [ ]

(A) excitation (B) meta-stable state (C) population inversion (D) emission

**II Fill in the blanks**

11. The acceptance angle of a fiber of numerical aperture 0.22, is \_\_\_\_\_°.

12. A \_\_\_\_\_ is a device for reducing the amount of noise emitted by a machine.

13. When the radius of a sphere is reduced to 2.0 nm, the surface area to volume ratio becomes

\_\_\_\_\_ per meter.

14. The unit for measurement of displacement vector is \_\_\_\_\_.

15. Above Curie temperature, the shape of B-H curve of a ferromagnetic material is in the form of a

\_\_\_\_\_.

16. The phenomenon of expulsion of magnetic lines from a super-conductor is known as

17. The unit of Einstein's coefficient is \_\_\_\_\_.
18. The synthesizing of nanomaterials from larger pieces of material, is called \_\_\_\_\_ technique.
19. Ionic Polarization is \_\_\_\_\_ temperature.
20. The active element in ruby laser is \_\_\_\_\_.

-oOo-

Code No: 09A1BS02 R09 Set No. 2  
I B.Tech Regular Examinations, June 2010  
ENGINEERING PHYSICS

Common to CE, ME, CHEM, BME, IT, MECT, MEP, AE, BT, AME, ICE,  
E.COMP.E, MMT, ETM, EIE, CSE, ECE, EEE

Time: 3 hours Max Marks: 75  
Answer any FIVE Questions  
All Questions carry equal marks

1. (a) What is statistical mechanics? Write notes on Bose-Einstein statistics.  
(b) Write notes on black body radiation.  
(c) Calculate the energies that can be possessed by a particle of mass  $8.50 \times 10^{-31}$  kg which is placed in an infinite potential box of width 10 cm. [6+5+4]
2. (a) What is the meaning of nanotechnology? Explain.  
(b) Describe the processes of "sol-gel" and "precipitation" in the fabrication of nano-structures.  
(c) Write the applications of nanotechnology in Electronic Industry. [4+7+4]
3. (a) Write notes on volume defects in crystals.  
(b) What is Burger's vector? What is Burger's circuit? Explain.  
(c) If the average energy required to create a Frenkel defect in an ionic crystal is 1.35 eV, calculate the ratio of Frenkel defects at 250C and 3500C. [5+6+4]
4. (a) Discuss the band theory of solids and explain the formation of bands and concept of holes.  
(b) What is effective mass of an electron? Derive an expression for the effective mass of an electron. [9+6]
5. (a) Explain the formation and properties of an ionic crystal, with a suitable example.  
(b) Derive an expression for the cohesive energy of an ionic crystal. [7+8]
6. (a) What is Meissner effect? Explain, in detail.  
(b) Distinguish a super-conductor and a normal metal, both maintained at same temperature.  
(c) Write notes on magnetic levitation. [5+5+5]
7. (a) Explain the characteristics of a laser beam.

- (b) Describe the construction of He-Ne laser and discuss with relevant ELD, the working of He-Ne laser.
- (c) What are the differences between a laser diode and an LED? [4+7+4]
- 1
8. (a) Derive an expression for carrier concentration of p-type semiconductors.
- (b) Explain Hall effect and its importance.
- (c) For a semiconductor, the Hall coefficient is  $-6.85 \times 10^{-5} \text{ m}^3/\text{coulomb}$ , and electrical conductivity is  $250 \text{ m}^{-1}$ . Calculate the density and mobility of the charge carriers. [7+4+4]



R09 Set No. 4

I B.Tech Regular Examinations, June 2010

ENGINEERING PHYSICS

Common to CE, ME, CHEM, BME, IT, MECT, MEP, AE, BT, AME, ICE,  
E.COMP.E, MMT, ETM, EIE, CSE, ECE, EEE

Time: 3 hours Max Marks: 75

Answer any FIVE Questions

All Questions carry equal marks

1. (a) Obtain an expression for Fermi energy at  $T > 0$  K.  
(b) Derive an expression for density of states of electrons.  
(c) Write short notes on:
  - i. De Broglie wavelength and
  - ii. Heisenberg's uncertainty principle. [4+7+4]
2. (a) Derive Bragg's law of crystal diffraction.  
(b) Describe, in detail, Debye-Scherrer method for the determination of crystal parameter.  
(c) A certain crystal reflects monochromatic X-rays strongly when Bragg's angle is  $210^\circ$  for the second order diffraction. Calculate the glancing angle for third order spectrum. [4+7+4]
3. (a) What is bonding in solids? Write the list of different types of bonding in solids.  
(b) Describe with suitable examples, the formation of covalent and Vander-Waal's bonds in solids.  
(c) What is bonding energy of a molecule? Explain. [4+7+4]
4. (a) Describe the top-down methods by which nanomaterials are fabricated.  
(b) Explain how X-ray diffraction can be used to characterize nanoparticles. [9+6]
5. (a) Discuss the propagation mechanism of light waves in optical fibers.  
(b) Derive the expression for the numerical aperture of an optical fiber.  
(c) A step index fiber has a numerical aperture of 0.16, and core refractive index of 1.45. Calculate the acceptance angle of the fiber and the refractive index of the cladding. [5+6+4]
6. (a) Using Kronig-Penney model show that the energy spectrum of an electron contains a number of allowed energy bands separated by forbidden bands.  
(b) Define effective mass of an electron. Explain its physical significance. [9+6]

7. (a) Show that the application of forward bias voltage across p-n junction causes

an exponential increase in number of charge carriers in opposite regions.

(b) Write notes on "Liquid Crystal Display".

(c) The current in a p-n junction at 27°C, is 0.18 mA when a large reverse bias voltage is applied. Calculate the current when a forward bias of 0.98 V is applied. [7+4+4]

8. (a) Define the terms magnetic induction (B), magnetization (M) and magnetic field (H). Obtain an expression relating to these quantities.

(b) What are ferrites? Prove that ferrites are superior to ferro-magnetic materials. Write the applications of ferrites.

(c) The magnetic susceptibility of aluminum is  $2.3 \times 10^{-5}$ . Find its permeability and relative permeability. [6+5+4]

Code No: 09A1BS02 R09 Set No. 1  
I B.Tech Regular Examinations, June 2010  
ENGINEERING PHYSICS

Common to CE, ME, CHEM, BME, IT, MECT, MEP, AE, BT, AME, ICE,  
E.COMP.E, MMT, ETM, EIE, CSE, ECE, EEE

Time: 3 hours Max Marks: 75

Answer any FIVE Questions

All Questions carry equal marks

1. (a) Explain the principle behind the functioning of an optical fibre.  
(b) Derive an expression for numerical aperture of an optical fibre.  
(c) Write any three applications of optical fibres. [4+7+4]
2. (a) Distinguish between intrinsic and extrinsic semiconductors.  
(b) Derive an expression for the density of holes in the valence band of an intrinsic semiconductor. [7+8]
3. (a) What is bonding in solids? Write the list of different types of bonding in solids.  
(b) Describe with suitable examples, the formation of ionic and covalent bonds in solids.  
(c) What is cohesive energy of a molecule? Explain. [4+7+4]
4. (a) What is Bloch theorem? Explain.  
(b) Write the conclusions given by Kronig-Penney model.  
(c) For an electron under motion in a periodic potential, plot the curve between the effective mass of the electron and wave number, and explain. [5+5+5]
5. (a) Describe any three processes by which nanomaterials are fabricated.  
(b) Describe the important applications of nanotechnology. [9+6]
6. (a) Define magnetic moment. What is Bohr magneton? Explain.  
(b) What are the characteristics of diamagnetic, paramagnetic and ferromagnetic substances? Explain their behavior with the help of examples.  
(c) If a magnetic field of strength 300 amp/metre produces a magnetization of 4200 A/m in a ferromagnetic material, find the relative permeability of the material. [3+9+3]

7. (a) Explain the concept of dual nature of the light.  
 (b) Describe the experimental verification of matter waves using Davisson-Germer experiment.  
 (c) Calculate the wavelength of matter wave associated with a neutron whose kinetic energy is 1.5 times the rest mass of electron.  
 (Given that Mass of neutron =  $1.676 \times 10^{-27}$  kg, Mass of electron =  $9.1 \times 10^{-31}$  kg, Planck's constant =  $6.62 \times 10^{-34}$  J-sec, Velocity of light =  $3 \times 10^8$  m/s). [4+7+4]
8. (a) Write notes on Bragg's law.  
 (b) Describe Bragg's X-ray spectrometer method in the determination crystal structure.  
 (c) Calculate the glancing angle of (1 1 1) plane of a cubic crystal having axial length 0.19 nm corresponding to the second order diffraction maximum for the X-rays of wavelength 0.058 nm. [4+7+4]

Code No: 09A1BS02 R09 Set No. 3

I B.Tech Regular Examinations, June 2010

ENGINEERING PHYSICS

Common to CE, ME, CHEM, BME, IT, MECT, MEP, AE, BT, AME, ICE, E.COMP.E, MMT, ETM, EIE, CSE, ECE, EEE

Time: 3 hours Max Marks: 75

Answer any FIVE Questions

All Questions carry equal marks

1. (a) Explain Fermi-Dirac distribution function. Illustrate the effect of temperature on the distribution.  
 (b) Derive an expression for density of states of an atom. [8+7]
2. (a) Derive the expressions for:  
 i. Acceptance angle and  
 ii. Numerical aperture of an optical fiber.  
 (b) Describe the different types of fibers by giving the refractive index profiles and propagation details. [8+7]
3. (a) What are Brillouin zones? Explain using E-K diagram.

- (b) Define effective mass of an electron. Explain its physical significance.
- (c) What is a hole? List out the properties of a hole. [5+5+5]
4. (a) Write notes on 'point defects' in crystals..
- (b) Derive the expression for the density of Frenkel defects in a metallic crystal.
- (c) What is Burgers vector? Explain. [5+5+5]
5. (a) Describe the different methods of acoustic quieting.
- (b) Describe various method to achieve soundproofing. [7+8]
6. (a) Explain the terms:
- Magnetic induction,
  - Magnetic susceptibility,
  - Permeability of a medium and
  - Intensity of magnetization.
- (b) What are hard and soft magnetic materials? Give their characteristic properties and applications.
- (c) A paramagnetic material has a magnetic field intensity of 104 amp/m. If the susceptibility of the material at room temperature is  $3.7 \times 10^{-3}$ . Calculate the magnetization and ux density of the material. [6+5+4]
7. (a) What do you understand by Miller indices of a crystal plane?
- (b) Show that in a cubic crystal the spacing (d) between consecutive parallel planes of Miller indices (h k l) is given by  $d = a / \sqrt{h^2 + k^2 + l^2}$ .
- (c) NaCl crystals have FCC structure. The density of NaCl is 2.18 gm/cm<sup>3</sup>. Calculate the distance between two adjacent atoms. (Molecular weight of NaCl = 58.5). [4+7+4]
8. (a) Derive an expression for density of electrons in intrinsic semiconductors.
- (b) Explain the variation of Fermi level with temperature in the case of p-type semiconductors.
- (c) If the effective mass of holes in a semiconductor is 5 times that of electrons, at what temperature would the Fermi level be shifted by 15% from the middle of the forbidden energy gap? [Given that the energy gap for the semiconductor is 1.20 eV]. [7+4+4]

*ALL  
THE  
BEST.....*

*Dept of physics*

JNTUWorld