

WSM

WORKSHOP MANUAL
TRACTOR

L2800, L3400

Kubota

TO THE READER

This Workshop Manual has been prepared to provide servicing personnel with information on the mechanism, service and maintenance of L2800 and L3400. It is divided into three parts, "General", "Mechanism" and "Servicing".

■ General

Information on the tractor identification, the general precautions, maintenance check list, check and maintenance and special tools are described.

■ Mechanism

Information on the construction and function are included. This part should be understood before proceeding with troubleshooting, disassembling and servicing.

Refer to Diesel Engine / Tractor Mechanism Workshop Manual (Code No. 9Y021-01874 / 9Y021-18201) for the one which has not been described to this workshop manual.

■ Servicing

Information on the troubleshooting, servicing specification lists, tightening torque, checking and adjusting, disassembling and assembling, and servicing which cover procedures, precautions, factory specifications and allowable limits.

All information illustrations and specifications contained in this manual are based on the latest product information available at the time of publication.

The right is reserved to make changes in all information at any time without notice.

Due to covering many models of this manual, information or picture being used have not been specified as one model.

January 2004

© KUBOTA Corporation 2004



SAFETY FIRST

This symbol, the industry's "Safety Alert Symbol", is used throughout this manual and on labels on the machine itself to warn of the possibility of personal injury. Read these instructions carefully.

It is essential that you read the instructions and safety regulations before you attempt to repair or use this unit.



DANGER

: Indicates an imminently hazardous situation which, if not avoided, will result in death or serious injury.



WARNING

: Indicates a potentially hazardous situation which, if not avoided, could result in death or serious injury.



CAUTION

: Indicates a potentially hazardous situation which, if not avoided, may result in minor or moderate injury.



IMPORTANT

: Indicates that equipment or property damage could result if instructions are not followed.



NOTE

: Gives helpful information.

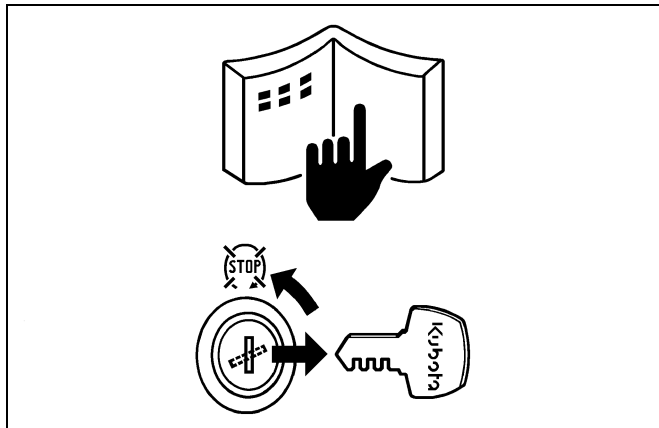

BEFORE SERVICING AND REPAIRING

- Read all instructions and safety instructions in this manual and on your machine safety decals.
- Clean the work area and machine.
- Park the machine on a firm and level ground, and set the parking brake.
- Lower the implement to the ground.
- Stop the engine, and remove the key.
- Disconnect the battery negative cable.
- Hang a "DO NOT OPERATE" tag in operator station.

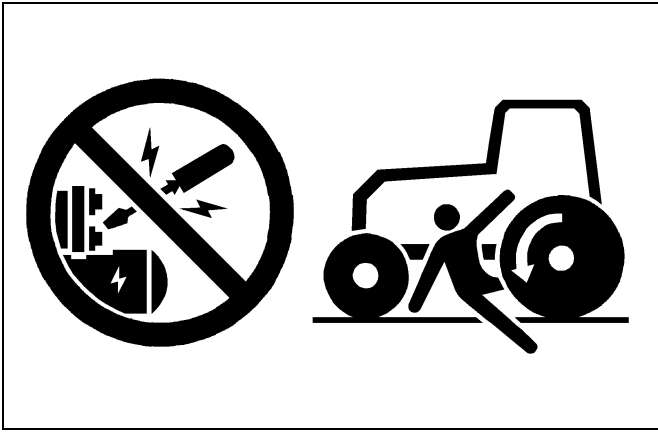

SAFETY STARTING

- Do not start the engine by shorting across starter terminals or bypassing the safety start switch.
- Do not alter or remove any part of machine safety system.
- Before starting the engine, make sure that all shift levers are in neutral positions or in disengaged positions.
- Never start the engine while standing on ground. Start the engine only from operator's seat.

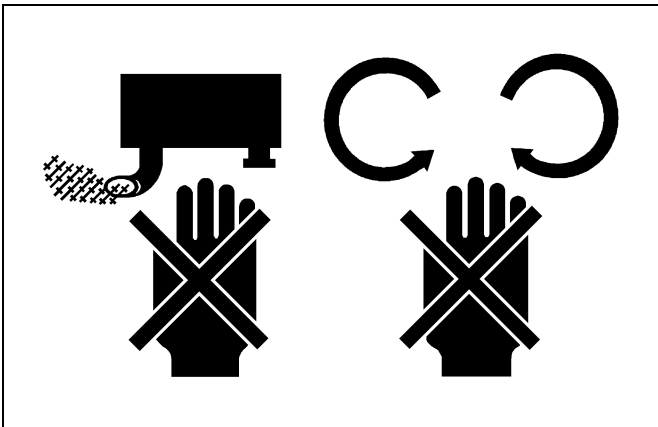

SAFETY WORKING

- Do not work on the machine while under the influence of alcohol, medication, or other substances or while fatigued.
- Wear close fitting clothing and safety equipment appropriate to the job.
- Use tools appropriate to the work. Makeshift tools, parts, and procedures are not recommended.
- When servicing is performed together by two or more persons, take care to perform all work safely.
- Do not work under the machine that is supported solely by a jack. Always support the machine by safety stands.
- Do not touch the rotating or hot parts while the engine is running.
- Never remove the radiator cap while the engine is running, or immediately after stopping. Otherwise, hot water will spout out from radiator. Only remove radiator cap when cool enough to touch with bare hands. Slowly loosen the cap to first stop to relieve pressure before removing completely.
- Escaping fluid (fuel or hydraulic oil) under pressure can penetrate the skin causing serious injury. Relieve pressure before disconnecting hydraulic or fuel lines. Tighten all connections before applying pressure.
- Do not open high-pressure fuel system. High-pressure fluid remaining in fuel lines can cause serious injury. Do not disconnect or attempt to repair fuel lines, sensors, or any other components between the high-pressure fuel pump and injectors on engines with high pressure common rail fuel system.
- High voltage exceeding 100 V is generated in the ECU and injector. Pay sufficient caution to electric shock when performing work activities.

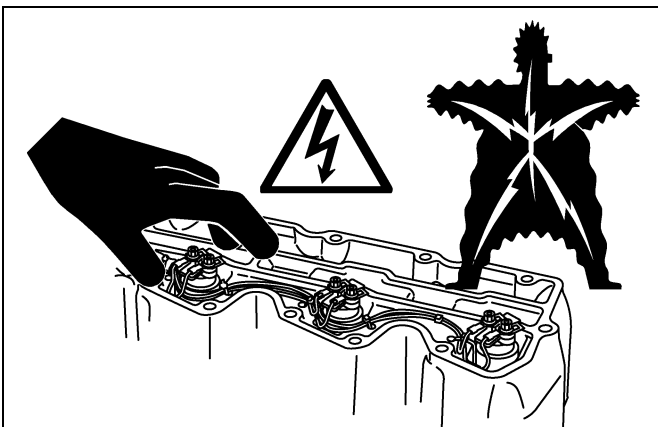
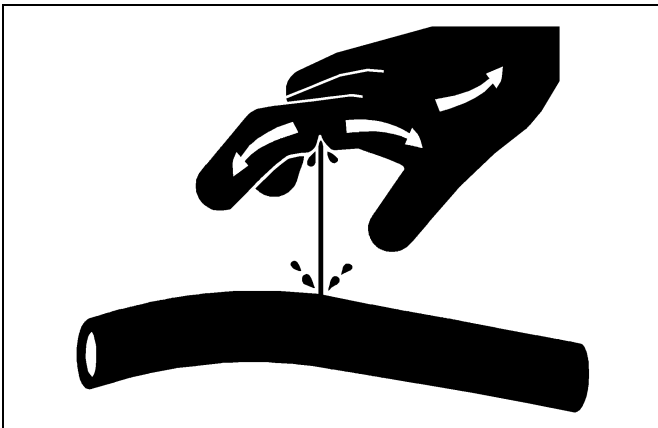

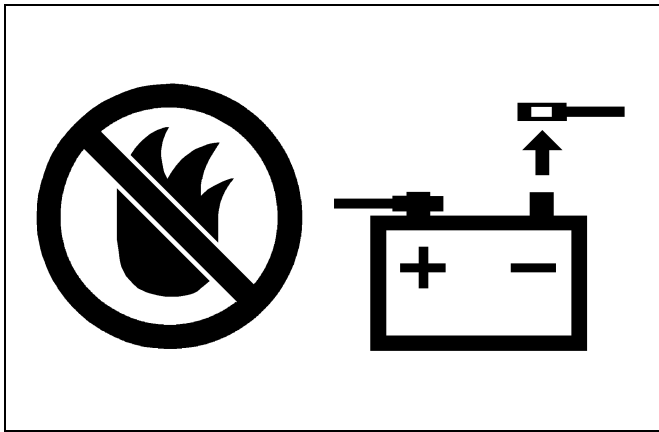

AVOID FIRES

- Fuel is extremely flammable and explosive under certain conditions. Do not smoke or allow flames or sparks in your working area.
- To avoid sparks from an accidental short circuit, always disconnect the battery negative cable first and connect it last.
- Battery gas can explode. Keep sparks and open flame away from the top of battery, especially when charging the battery.
- Make sure that no fuel has been spilled on the engine.

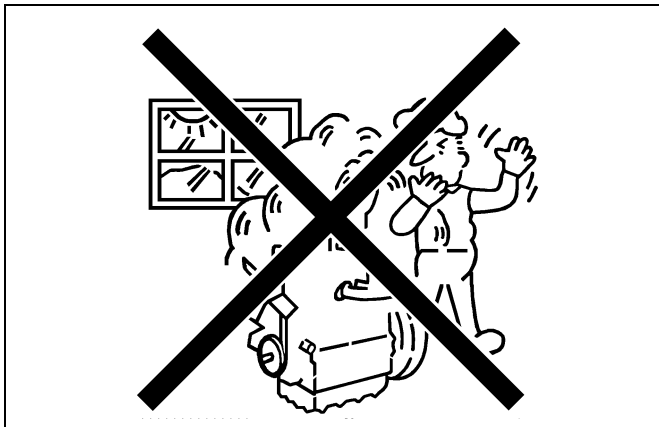

VENTILATE WORK AREA

- If the engine must be running to do some work, make sure the area is well ventilated. Never run the engine in a closed area. The exhaust gas contains poisonous carbon monoxide.

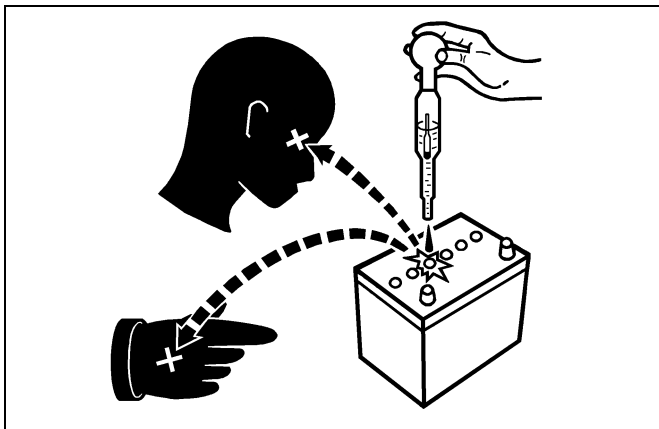

PREVENT ACID BURNS

- Sulfuric acid in battery electrolyte is poisonous. It is strong enough to burn skin, clothing and cause blindness if splashed into eyes. Keep electrolyte away from eyes, hands and clothing. If you spill electrolyte on yourself, flush with water, and get medical attention immediately.

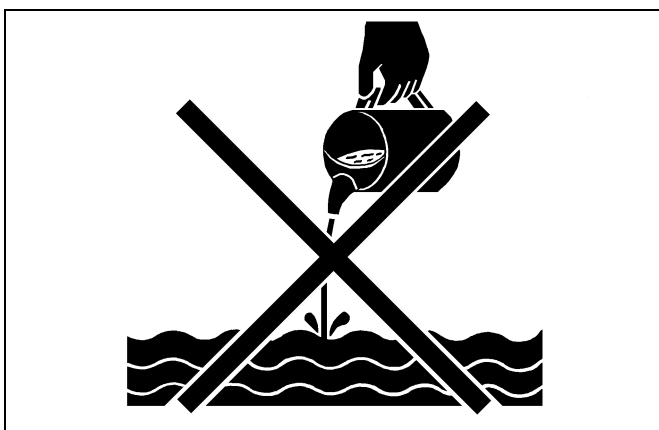

DISPOSE OF FLUIDS PROPERLY

- Do not pour fluids into the ground, down a drain, or into a stream, pond, or lake. Observe relevant environmental protection regulations when disposing of oil, fuel, coolant, electrolyte and other harmful waste.

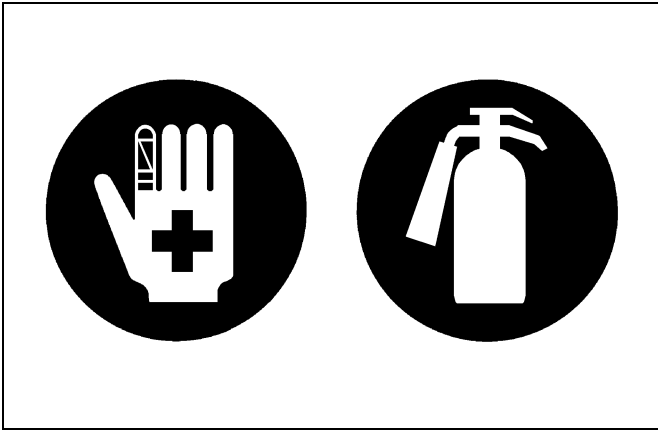
**PREPARE FOR EMERGENCIES**

- Keep a first aid kit and fire extinguisher handy at all times.
- Keep emergency numbers for doctors, ambulance service, hospital and fire department near your telephone.

SAFETY DECALS



The following safety decals are installed on the machine.

If a decal becomes damaged, illegible or is not on the machine, replace it. The decal part number is listed in the parts list.

(1) Part No. TA040-4965-2

	<p style="text-align: center;">⚠ DANGER</p> <p>TO AVOID POSSIBLE INJURY OR DEATH FROM A MACHINE RUNAWAY.</p> <ol style="list-style-type: none"> 1. Do not start engine by shorting across starter terminals or bypassing the safety start switch. Machine may start in gear and move if normal starting circuitry is bypassed. 2. Start engine only from operator's seat with transmission and PTO OFF. Never start engine while standing on the ground.
---	--

(4) Part No. TA040-4956-2
Diesel fuel only. No fire

	
---	---

(2) Part No. TA040-4959-3

	<p style="text-align: center;">⚠ WARNING</p> <p>TO AVOID PERSONAL INJURY.</p> <ol style="list-style-type: none"> 1. Keep PTO shield in place at all times. 2. Do not operate the PTO at speeds faster than the speed recommended by the implement manufacturer. 3. For trailing PTO-driven implements, set drawbar at towing position. (see operator's manual)
--	---

(5) Part No. TA040-4935-1

<p style="text-align: center;">⚠ WARNING</p> <p>TO AVOID PERSONAL INJURY:</p> <ol style="list-style-type: none"> 1. Attach pulled or towed loads to the drawbar only. 2. Use the 3-point hitch only with equipment designed for 3-point hitch usage.
--

(3) Part No. TA140-4933-1 [Manual Transmission type]

<p>⚠ WARNING</p> 	<p>BEFORE DISMOUNTING TRACTOR:</p> <ol style="list-style-type: none"> 1. ALWAYS SET PARKING BRAKE. 2. PARK ON LEVEL GROUND WHENEVER POSSIBLE. If parking on a slope, position tractor across the slope. 3. LOWER ALL IMPLEMENTS TO THE GROUND. Failure to comply to this warning may allow the wheels to slip, and could cause injury or death. 4. LOCK SHUTTLE SHIFT LEVER IN NEUTRAL POSITION AND STOP THE ENGINE.
---	---

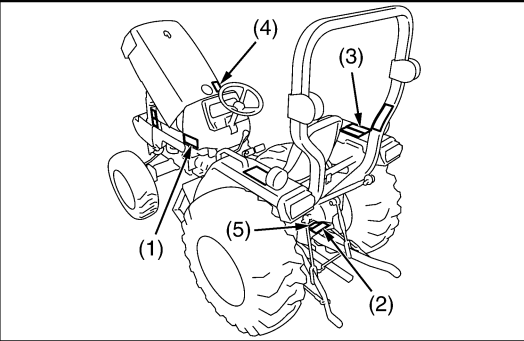

(3) Part No. TA240-4933-2 [HST type]

<p>⚠ WARNING</p> 	<p>BEFORE DISMOUNTING TRACTOR:</p> <ol style="list-style-type: none"> 1. ALWAYS SET PARKING BRAKE. Leaving transmission in gear with the engine stopped will not prevent tractor from rolling. 2. PARK ON LEVEL GROUND WHENEVER POSSIBLE. If parking on a slope, position tractor across the slope. 3. LOWER ALL IMPLEMENTS TO THE GROUND. Failure to comply to this warning may allow the wheels to slip, and could cause injury or death. 4. STOP THE ENGINE.
---	--

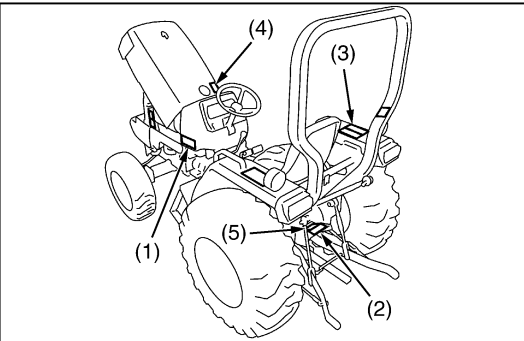

(1) Part No. 35260-3491-4

CAUTION

TO AVOID PERSONAL INJURY:

1. Read and understand the operator's manual before operation.
2. Before starting the engine, make sure that everyone is at a safe distance from the tractor and that the PTO is OFF.
3. Do not allow passengers on the tractor at any time.
4. Before allowing other people to use the tractor, have them read the operator's manual.
5. Check the tightness of all nuts and bolts regularly.
6. Keep all shields in place and stay away from all moving parts.
7. Lock the two brake pedals together before driving on the road.
8. Slow down for turns, or rough roads, or when applying individual brakes.
9. On public roads use SMV emblem and hazard lights, if required by local traffic and safety regulations.
10. Pull only from the drawbar.
11. Before dismounting, lower the implement to the ground, set the parking brake, stop the engine and remove the key.
12. Securely support tractor and implements before working underneath.

(3) Part No. 32751-4958-1
Stay clear of engine fan and fan belt.



(2) Part No. TD030-3012-2

<p>LEAD RECYCLE</p>	<p>FLAMMABLES</p>	<p>SHIELD EYES</p>	<p>KEEP OUT OF THE REACH OF CHILDREN</p>	<p>CAUTIONS OF SULFURIC ACID</p>	<p>READ INSTRUCTION MANUAL CAREFULLY</p>	<p>EXPLOSIVE</p>	<p>HYDROMETER</p> <p>OK CHARGE REPLACE BATTERY BATTERY</p> <p>DK 82105</p>
<p>NS70MF 12V</p> <p>AMP. HR (GHR) 52</p> <p>RESERVE CAPACITY (MIN) 123</p> <p>COLD CRANKING AMPS (-18°C) 490</p>	<p>DANGER</p> <p>- DUE TO HYDROGEN GAS GENERATED FROM BATTERY, HANDLING WITHOUT CARE CAN CAUSE FIRE AND EXPLOSION.</p> <p>- THIS 12V BATTERY IS ONLY FOR STARTING ENGINE. DO NOT APPLY THIS PRODUCT FOR OTHER USES.</p> <p>- CHARGE THIS BATTERY ONLY AT WELL VENTILATED PLACES, AND AVOID SHORTS OR SPARKS.</p> <p>- REFER TO THE INSTRUCTION MANUAL OF VEHICLE OR BATTERY BEFORE USING BOOSTER CABLE.</p> <p>- SULFURIC ACID MAY CAUSE BLINDNESS OR SEVERE BURN. IN CASE EYES, SKIN, CLOTHES OR ANY ARTICLES ARE STAINED WITH ACID, FLUSH OBJECTS IMMEDIATELY WITH WATER. IF ACID BEING SWALLOWED, DRINK PLENTY OF WATER PROMPTLY. IN CASE OF ACCIDENTAL CONTACT, CONSULT A DOCTOR IMMEDIATELY.</p> <p>- BATTERY FILLED WITH ACID (DO NOT TILT OR SPILL) - FLAMMABLE. DO NOT CHARGE NEAR FIRE OR SPARKS</p> <p>- DO NOT CHARGE RAPIDLY - DO NOT DISASSEMBLE THE BATTERY (SEALED TYPE)</p>						<p>75D26R</p> <p>FITTING DATE</p> <p>0 1 2 3 4 5 6 7 8 9 YEAR</p> <p>1 2 3 4 5 6 7 8 9 10 11 12 MONTH</p>
<p>DANGER EXPLOSIVE GASES</p> <p>Cigarettes, flames or sparks could cause battery to explode. Always shield eyes and face from battery. Do not charge or use booster cables or adjust post connections without proper instruction and training.</p>			<p>POISON CAUSES SEVERE BURNS</p> <p>Contains sulfuric acid. Avoid contact with skin, eyes or clothing. In event of accident flush with water and call a physician immediately.</p> <p>KEEP OUT OF REACH OF CHILDREN</p>				

(4) Part No. TD030-4958-1
Do not touch hot surface like muffler, etc.

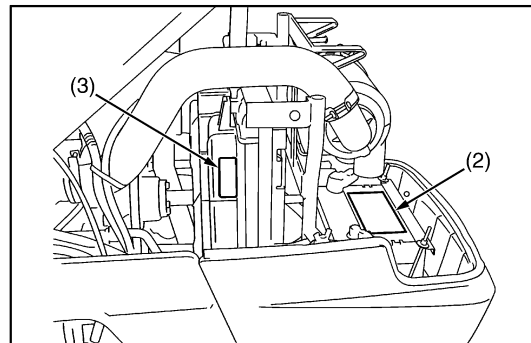
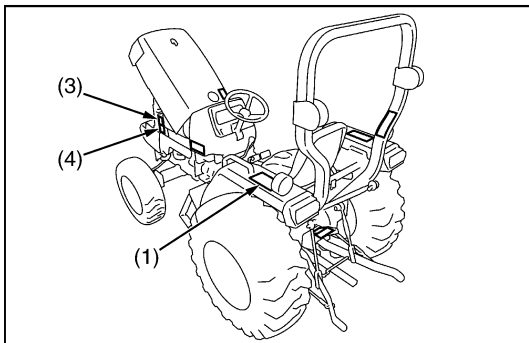

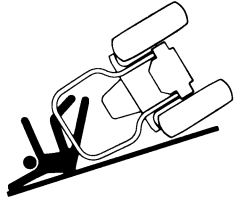

3TLAAABCP002A

(1) Part No. TA040-4932-2 [Rigid ROPS type]

 WARNING	<p>TO AVOID PERSONAL INJURY OR DEATH FROM ROLL-OVER:</p> <ol style="list-style-type: none"> 1. Kubota recommends the use of a Roll-Over Protective Structures (ROPS) and seat belt in almost all applications. 2. Remove the ROPS only when it substantially interferes with operation or itself presents a safety risk. (Examples include work in orchards and vineyards) ALWAYS REINSTALL IT BEFORE USING THE TRACTOR IN OTHER APPLICATIONS. 3. Never use just the seat belt or just the ROPS. They must be used together. For further details, consult your Operator's Manual or your local dealer.
	

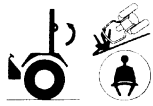

(2) Part No. TA240-9848-1 [Foldable ROPS type]

 WARNING	<p>TO AVOID INJURY OR DEATH FROM ROLL-OVER:</p> <ul style="list-style-type: none"> • Keep Roll-Over Protective Structures (ROPS) in the upright and locked position • Fasten SEAT BELT before operating <p>THERE IS NO OPERATOR PROTECTION WHEN THE ROPS IS IN THE FOLDED POSITION:</p> <ul style="list-style-type: none"> • Check the operating area and fold the ROPS only when absolutely necessary • Do not wear SEAT BELT if ROPS is folded • Raise and lock ROPS as soon as vertical clearance allows • Read ROPS related instructions and warnings
	
	

(3) Part No. 6C140-4746-1 [Rigid ROPS type]

 WARNING
<p>TO AVOID PERSONAL INJURY:</p> <p>Do not modify or repair a ROPS because welding, grinding, drilling or cutting any portion may weaken the structure.</p>

(4) Part No. 3A111-9544-1 [Foldable ROPS type]

 WARNING
<p>Never modify or repair a ROPS because welding, grinding, drilling or cutting any portion may weaken the structure.</p>
 CAUTION
<p>TO AVOID INJURY WHEN RAISING OR FOLDING ROPS:</p> <ul style="list-style-type: none"> • Set parking brake and stop engine. • Remove any obstruction that may prevent raising or folding of the ROPS. • Do not allow any bystanders. • Always perform function from a stable position at the rear of the tractor. • Hold the top of the ROPS securely when raising or folding. • Make sure all pins are installed and locked.

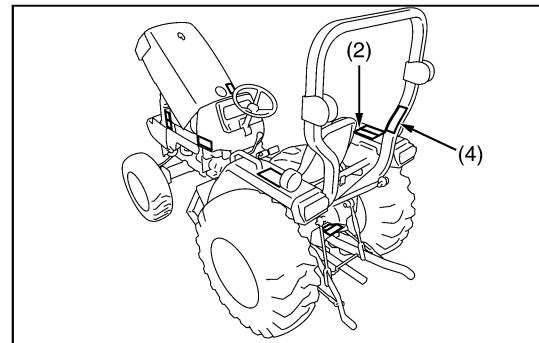
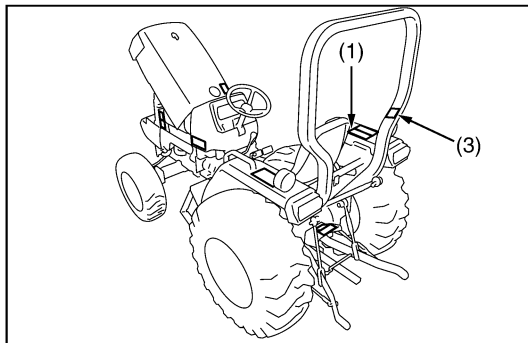

CARE OF DANGER, WARNING AND CAUTION LABELS

1. Keep danger, warning and caution labels clean and free from obstructing material.
2. Clean danger, warning and caution labels with soap and water, dry with a soft cloth.
3. Replace damaged or missing danger, warning and caution labels with new labels.
4. If a component with danger, warning or caution label(s) affixed is replaced with new part, make sure new label(s) is (are) attached in the same location(s) as the replaced component.
5. Mount new danger, warning and caution labels by applying on a clean dry surface and pressing any bubbles to outside edge.

3TLAAABCP011A

SPECIFICATIONS

Model		L2800		L3400		
		2WD	4WD	4WD	4WD	
PTO power		17.9 kW (24.0 HP)		21.6 kW (29.0 HP)		
Engine	Maker	KUBOTA				
	Model	D1403-M-E2A		D1703-MA-E2A		
	Type	Vertical, water-cooled, 4-cycle diesel				
	Number of cylinders	3		3		
	Bore and stroke	80 × 92.4 mm (3.1 × 3.6 in.)		87 × 92.4 mm (3.4 × 3.6 in.)		
	Total displacement	1.393 L (85.0 cu.in.)		1.647 L (101.0 cu.in.)		
	Engine gross power	21.6 kW (29.0 HP)		25.9 kW (34.7 HP)		
	Rated revolution	46.7 rps (2800 min ⁻¹ (rpm))		45.0 rps (2700 min ⁻¹ (rpm))		
	Maximum torque	89.2 N·m (65.8 ft-lbs)		108.6 N·m (80.1 ft-lbs)		
	Battery	12 V. RC : 123 min, CCA : 490 A				
	Fuel	Diesel fuel No. 2-D				
Capacities	Fuel tank	34.0 L (9.0 U.S.gals)				
	Engine crankcase (with filter)	5.7 L (6.0 U.S.qts)				
	Engine coolant	6.0 L (6.3 U.S.qts)				
	Transmission case	27.0 L (7.1 U.S.gals)	27.5 L (7.3 U.S.gals)	27.0 L (7.1 U.S.gals)	27.5 L (7.3 U.S.gals)	
Dimensions	Overall length (without 3P)	2810 mm (110.6 in.)	2705 mm (106.5 in.)	2810 mm (110.6 in.)	2705 mm (106.5 in.)	
	Overall width (minimum tread)	1305 mm (51.4 in.)				
	Overall height (with ROPS)	2160 mm (85.0 in.)				
	Overall height (Top of steering wheel)	1475 mm (58.1 in.)				
	Wheel base	1610 mm (63.3 in.)				
	Min.ground clearance	345 mm (13.6 in.)	340 mm (13.4 in.)	345 mm (13.6 in.)	340 mm (13.4 in.)	
	Tread	Front 1050 mm (41.3 in.)	1095 mm (43.1 in.)	1050 mm (41.3 in.)	1095 mm (43.1 in.)	
	Rear	1290 mm (50.8 in.)				
Weight (with ROPS)		1070 kg (2359 lbs)	1150 kg (2536 lbs)	1090 kg (2403 lbs)	1170 kg (2580 lbs)	
Clutch		Dry type single stage		Dry type dual stage		
Traveling system	Tires	AG Front	5.00 - 15	7.00 - 16	5.00 - 15	7.00 - 16
		AG Rear	11.2 - 24			
	Indust. (option) Front / Rear	-	27 × 8.50 - 15 / 15 - 19.5R4	-	27 × 8.50 - 15 / 15 - 19.5R4	
	Steering	Integral type power steering				
	Transmission	Gear shift, 8 forward and 4 reverse				
	Brake	Wet disk type				
Min. turning radius (with brake)		2.4 m (7.9 feet)				

W1028103

(continued)

Model		L2800		L3400		
		2WD	4WD	4WD	4WD	
Hydraulic unit	Hydraulic control system	Position control				
	Pump capacity (main)	24.7 L/min (6.5 gal/min)		23.9 L/min (6.3 gal/min)		
	Pump capacity (PS)	15.0 L/min (4.0 gal/min)		14.5 L/min (3.8 gal/min)		
	Three point hitch	Category 1				
	Max. lift force	At lift points	906 kg (1998 lbs)			
		24 in. behind lift points	651 kg (1435 lbs)			
	System pressure	15.7 MPa (160 kgf/cm ²)				
PTO	Rear PTO	SAE 1-3/8, 6-splines (with overrunning clutch on single clutch tractor)				
	PTO / Engine speed	540 / 2430 min ⁻¹ (rpm)		540 / 2425 min ⁻¹ (rpm)		

NOTE: *Manufacture's estimate

The company reserves the right to change the specifications without notice.

W1032744

Model		L2800	L3400
		4WD HST	4WD HST
PTO power*		16.8 kW (22.5 HP)	20.5 kW (27.5 HP)
Engine	Maker	KUBOTA	
	Model	D1403-M-E2A	D1703-MA-E2A
	Type	Indirect injection, Vertical, Water-cooled 4 cycle diesel	
	Number of cylinders	3	
	Bore and stroke	80 × 92.4 mm (3.1 × 3.6 in.)	87 × 92.4 mm (3.4 × 3.6 in.)
	Total displacement	1.393 L (85.0 cu.in.)	1.647 L (101.0 cu.in.)
	Engine gross power*	21.6 kW (29.0 HP)	25.9 kW (34.7 HP)
	Engine net power*	20.5 kW (27.5 HP)	24.8 kW (33.3 HP)
	Rated revolution	46.7 rps (2800 min ⁻¹ (rpm))	45.0 rps (2700 min ⁻¹ (rpm))
	Maximum torque	89.2 N·m (65.8 ft-lbs)	108.6 N·m (80.1 ft-lbs)
	Battery	12 V. RC : 123 min, CCA : 490 A	
	Fuel	Diesel fuel No. 1-D, No. 2-D	
Capacities	Fuel tank	34.0 L (9.0 U.S.gals)	
	Engine crankcase (with filter)	5.7 L (6.0 U.S.qts)	
	Engine coolant	6.0 L (6.3 U.S.qts)	
	Transmission case	23.5 L (6.2 U.S.gals)	23.5 L (6.2 U.S.gals)
Dimensions	Overall length (with 3P)	2705 mm (106.5 in.)	
	Overall width (minimum tread)	1305 mm (51.4 in.)	
	Overall height (with ROPS)	2160 mm (85.0 in.)	
	Overall height (Top of steering wheel)	1475 mm (58.1 in.)	
	Wheel base	1610 mm (63.3 in.)	
	Min.ground clearance	340 mm (13.4 in.)	340 mm (13.4 in.)
	Tread	Front	1095 mm (43.1 in.)
Rear		1020 mm (40.2 in.), 1115 mm (43.8 in.), 1195 mm (47.1 in.), 1290 mm (50.8 in.)	
Weight (with ROPS)		1180 kg (2600 lbs)	1180 kg (2600 lbs)
Traveling system	Tires	AG Front	7.00 - 16
		AG Rear	11.2 - 24
	Indust. (option) Front / Rear	27 × 8.50 - 15 / 15 - 19.5R4	27 × 8.50 - 15 / 15 - 19.5R4
	Clutch	Dry type single stage	
	Steering	Integral type power steering	
	Transmission	Hydrostatic transmission, 3 range speed	
	Brake	Wet disk type	
Min. turning radius (with brake)		2.5 m (8.2 feet)	

(Continued)

Model		L2800	L3400	
		4WD HST	4WD HST	
Hydraulic unit	Hydraulic control system		Position control	
	Pump capacity (main)		24.7 L/min (6.5 gal/min) 23.9 L/min (6.3 gal/min)	
	Pump capacity (PS)		15.0 L/min (4.0 gal/min) 14.5 L/min (3.8 gal/min)	
	Three point hitch		Category 1	
	Max. lift force	At lift points	906 kg (1998 lbs)	
		24 in. behind lift points	651 kg (1435 lbs)	
System pressure		15.7 MPa (160 kgf/cm ²)		
PTO	Rear PTO	PTO shaft size	SAE 1-3/8, 6-splines	
		Type	Live-continuous with overrunning clutch Live-continuous with overrunning clutch	
	PTO / Engine speed		540 / 2580 min ⁻¹ (rpm) 540 / 2580 min ⁻¹ (rpm)	

NOTE: *Manufacture's estimate

The company reserves the right to change the specifications without notice.

W1031656

DIMENSIONS

L2800 · L3400 [Manual Transmission Type]

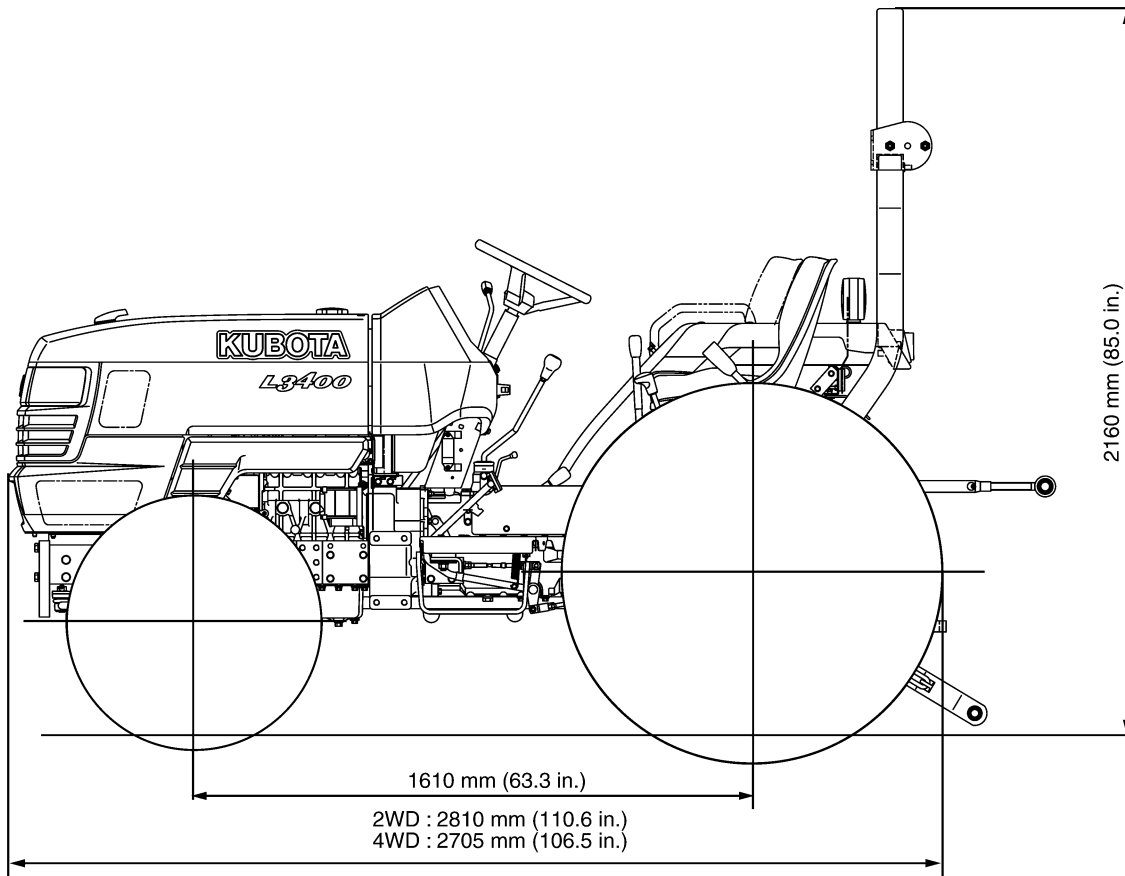
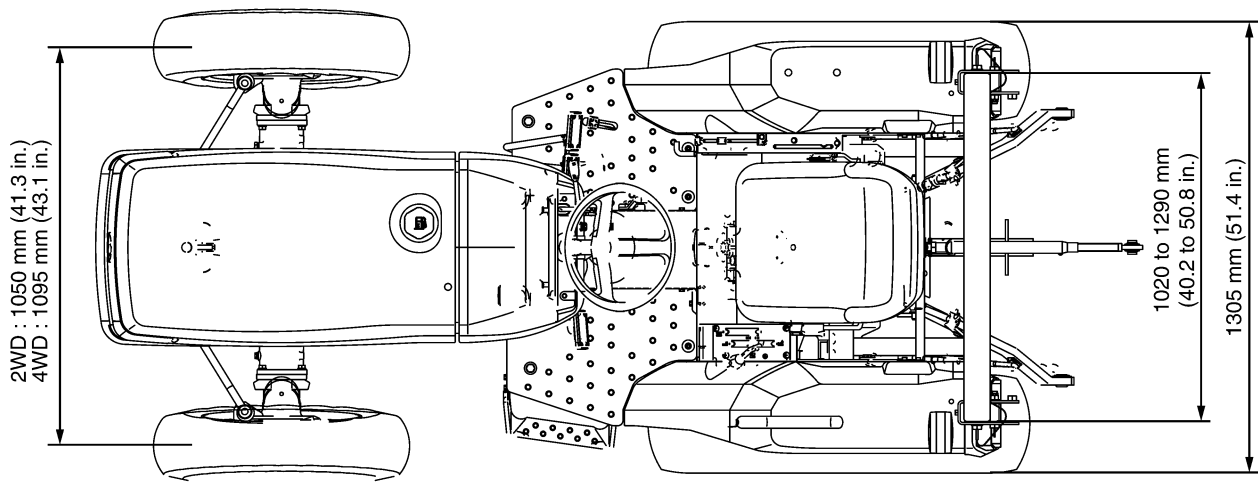

3TLAAABFP003A

L2800 · L3400 [HST Type]

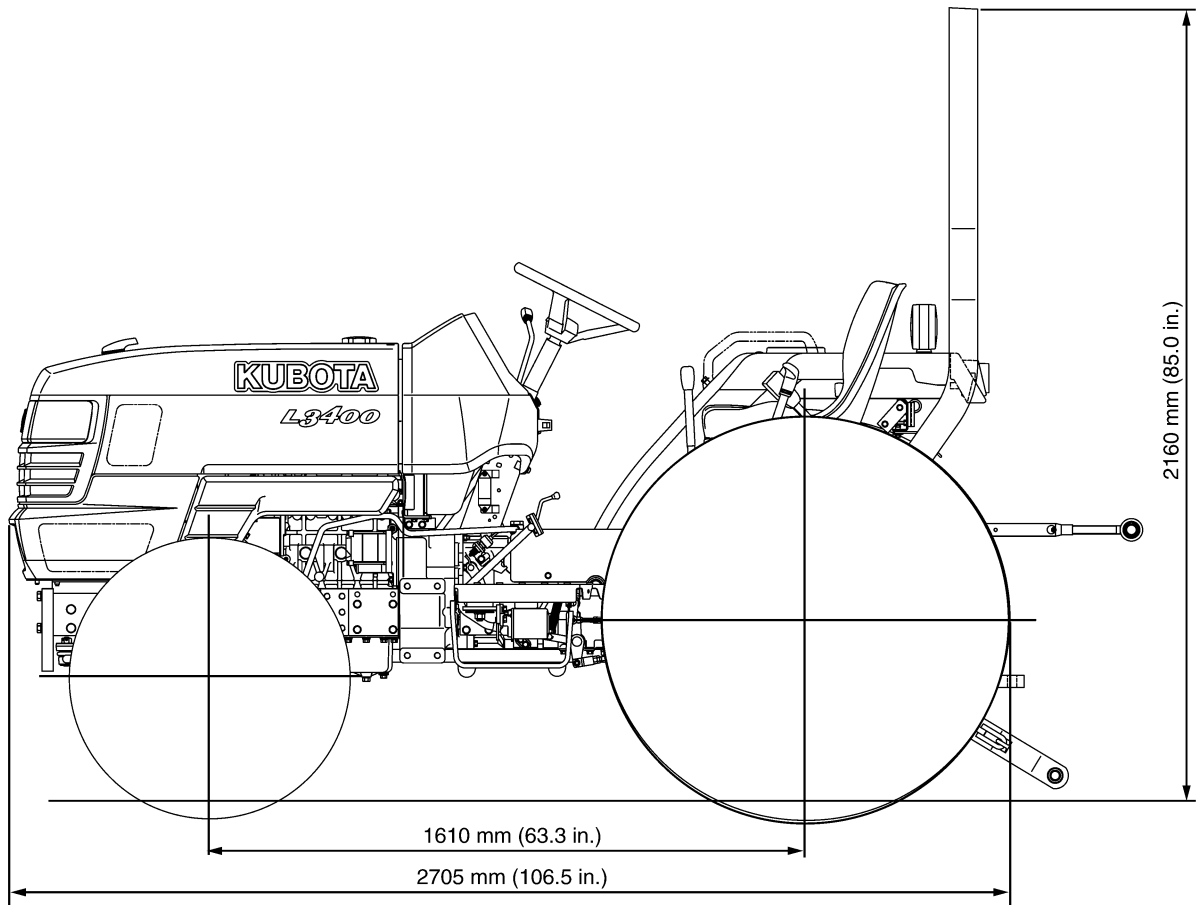
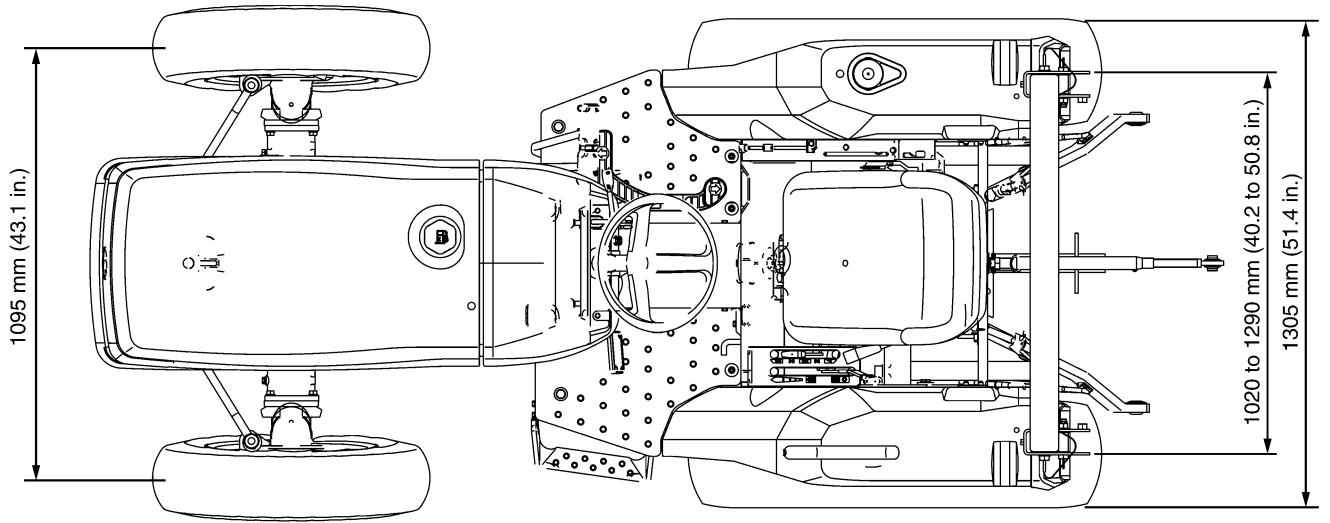

3TLAABFP002A

G GENERAL

GENERAL

CONTENTS

1. TRACTOR IDENTIFICATION	G-1
2. GENERAL PRECAUTIONS	G-2
3. HANDLING PRECAUTIONS FOR ELECTRICAL PARTS AND WIRING..	G-3
[1] WIRING.....	G-3
[2] BATTERY.....	G-5
[3] FUSE.....	G-5
[4] CONNECTOR.....	G-5
4. LUBRICANTS, FUEL AND COOLANT	G-7
5. TIGHTENING TORQUES	G-9
[1] GENERAL USE SCREWS, BOLTS AND NUTS.....	G-9
6. MAINTENANCE	G-10
7. CHECK AND MAINTENANCE	G-13
[1] DAILY CHECK	G-13
[2] CHECK POINTS OF INITIAL 50 HOURS.....	G-14
[3] CHECK POINTS OF EVERY 50 HOURS.....	G-21
[4] CHECK POINTS OF EVERY 100 HOURS.....	G-25
[5] CHECK POINTS OF EVERY 200 HOURS.....	G-30
[6] CHECK POINTS OF EVERY 400 HOURS.....	G-32
[7] CHECK POINTS OF EVERY 600 HOURS.....	G-33
[8] CHECK POINTS OF EVERY 800 HOURS.....	G-33
[9] CHECK POINTS OF EVERY 1500 HOURS.....	G-33
[10]CHECK POINTS OF EVERY 3000 HOURS.....	G-33
[11]CHECK POINTS OF EVERY 1 YEARS.....	G-33
[12]CHECK POINTS OF EVERY 2 YEARS.....	G-34
[13]OTHERS	G-38
8. SPECIAL TOOLS.....	G-40
[1] SPECIAL TOOLS FOR ENGINE	G-40
[2] SPECIAL TOOLS FOR TRACTOR.....	G-46
9. TIRES.....	G-55
[1] TIRE PRESSURE	G-55
[2] TREADS ADJUSTMENT	G-56
(1) Front Wheel	G-56
(2) Rear Wheels	G-57
[3] TIRE LIQUID INJECTION.....	G-58
[4] IMPLEMENT LIMITATIONS.....	G-62

1. TRACTOR IDENTIFICATION

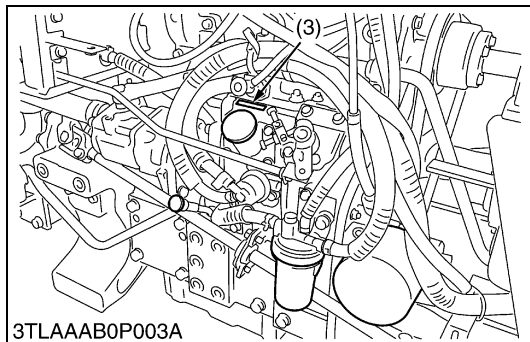
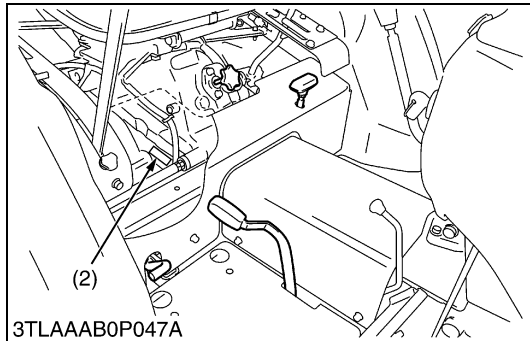
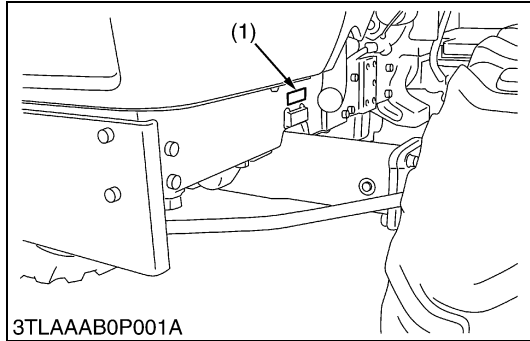

When contacting your local KUBOTA distributor, always specify engine serial number, tractor serial number and hour meter reading.

- (1) Tractor Identification Plate
- (2) Tractor Serial Number
- (3) Engine Serial Number

W1010606

2. GENERAL PRECAUTIONS

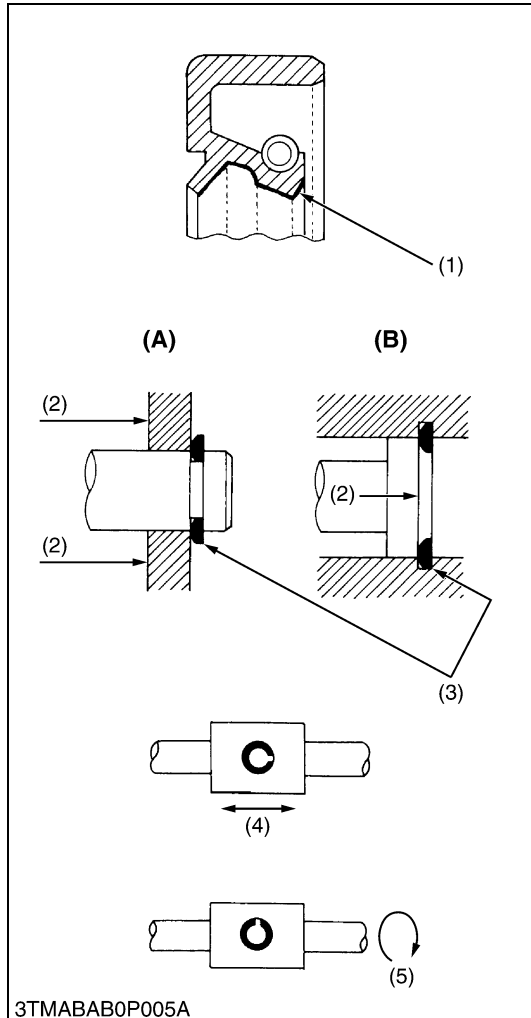

- During disassembly, carefully arrange removed parts in a clean area to prevent confusion later. Screws, bolts and nuts should be installed in their original position to prevent reassembly errors.
- When special tools are required, use KUBOTA genuine special tools. Special tools which are not frequently used should be made according to the drawings provided.
- Before disassembling or servicing electrical wires, always disconnect the ground cable from the battery first.
- Remove oil and dirt from parts before measuring.
- Use only KUBOTA genuine parts for parts replacement to maintain machine performance and to assure safety.
- Gaskets and O-rings must be replaced during reassembly. Apply grease to new O-rings or oil seals before assembling. See the figure left side.
- When reassembling external snap rings or internal snap rings, they must be positioned so that sharp edge faces against the direction from which a force is applied. See the figure left side.
- When inserting spring pins, their splits must face the direction from which a force is applied. See the figure left side.
- To prevent damage to the hydraulic system, use only specified fluid or equivalent.

- (1) Grease
 (2) Force
 (3) Sharp Edge
 (4) Axial Force
 (5) Rotating Movement

- (A) External Snap Ring
 (B) Internal Snap Ring

W1010904

3. HANDLING PRECAUTIONS FOR ELECTRICAL PARTS AND WIRING

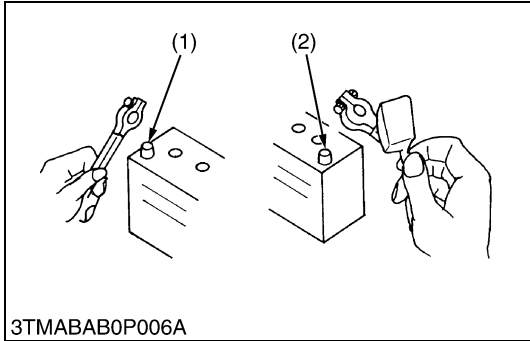

To ensure safety and prevent damage to the machine and surrounding equipment, heed the following precautions in handling electrical parts and wiring.

■ IMPORTANT

- Check electrical wiring for damage and loosened connection every year. To this end, educate the customer to do his or her own check and at the same time recommend the dealer to perform periodic check for a fee.
- Do not attempt to modify or remodel any electrical parts and wiring.
- When removing the battery cables, disconnect the negative cable first. When installing the battery cables, connect the positive cable first.

- (1) Negative Terminal (2) Positive Terminal

W1011114

[1] WIRING

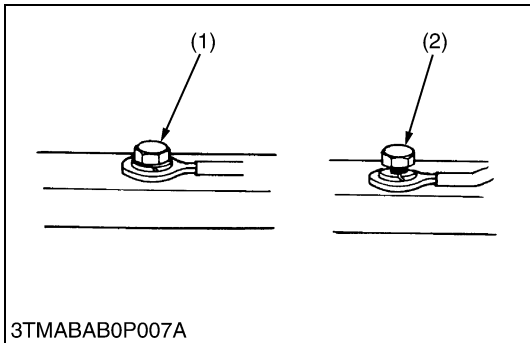

- Securely tighten wiring terminals.

- (1) Correct (Securely Tighten) (2) Incorrect (Loosening Leads to Faulty Contact)

W1011216

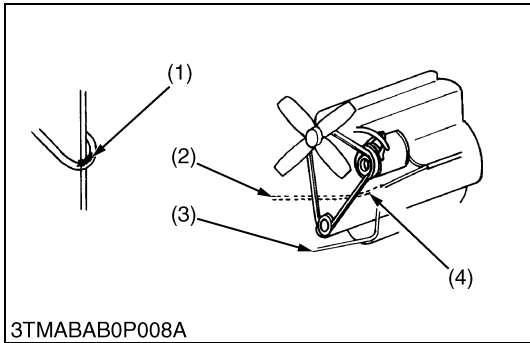

- Do not let wiring contact dangerous part.

- (1) Dangerous Part (2) Wiring (Incorrect) (3) Wiring (Correct) (4) Dangerous Part

W1011313

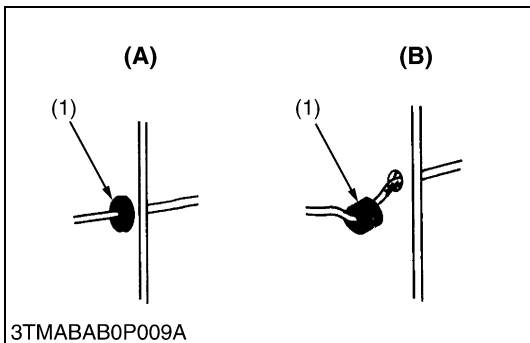

- Securely insert grommet.

- (1) Grommet (A) Correct (B) Incorrect

W1011388

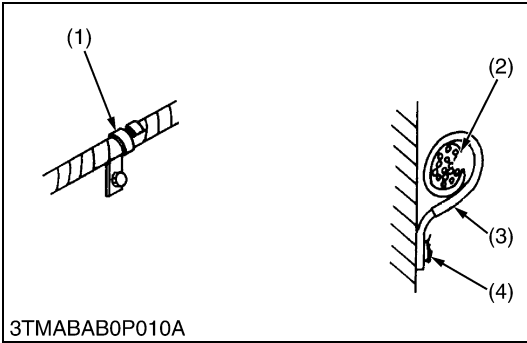

- Securely clamp, being careful not to damage wiring.

- (1) Clamp
 - Wind Clamp Spirally
- (2) Wire Harness
- (3) Clamp
- (4) Welding Dent

W1011458

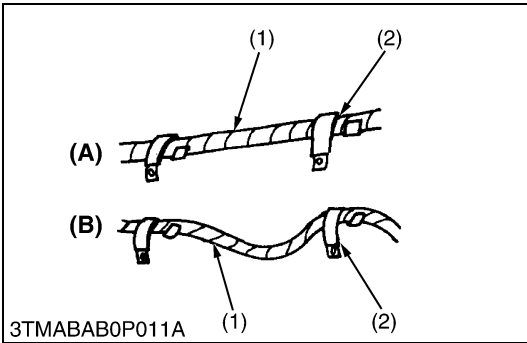

- Clamp wiring so that there is no twist, unnecessary sag, or excessive tension, except for movable part, where sag be required.

- (1) Wiring
- (2) Clamp
- (A) Correct
- (B) Incorrect

W1011587

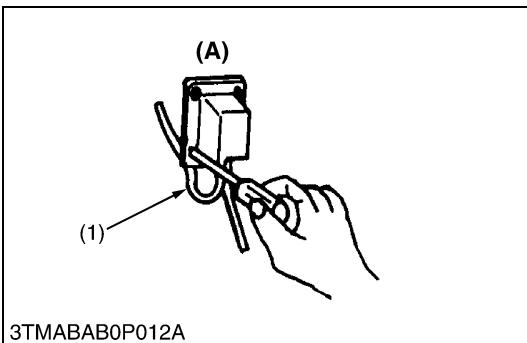

- In installing a part, take care not to get wiring caught by it.

- (1) Wiring
- (A) Incorrect

W1011670

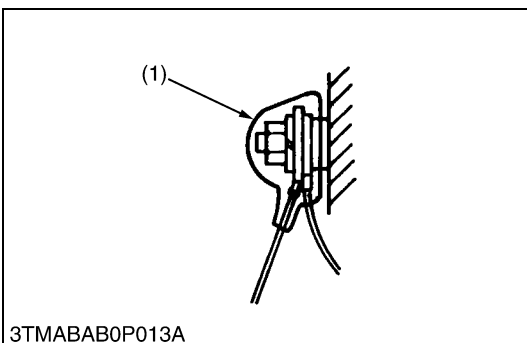

- After installing wiring, check protection of terminals and clamped condition of wiring, only connect battery.

- (1) Cover
 - Securely Install Cover

W1011735

[2] BATTERY

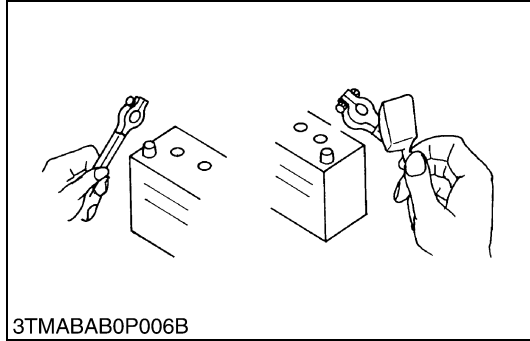

- Take care not to confuse positive and negative terminal posts.
- When removing battery cables, disconnect negative cable first. When installing battery cables, check for polarity and connect positive cable first.
- Do not install any battery with capacity other than is specified (Ah).
- After connecting cables to battery terminal posts, apply high temperature grease to them and securely install terminal covers on them.
- Do not allow dirt and dust to collect on battery.

CAUTION

- Take care not to let battery liquid spill on your skin and clothes. If contaminated, wash it off with water immediately.
- Before recharging the battery, remove it from the machine.
- Before recharging, remove cell caps.
- Do recharging in a well-ventilated place where there is no open flame nearby, as hydrogen gas and oxygen are formed.

W1011816

[3] FUSE

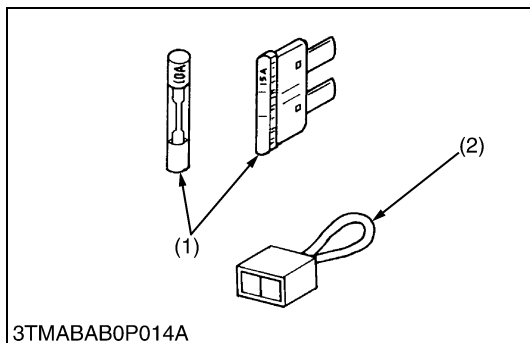

- Use fuses with specified capacity. Neither too large or small capacity fuse is acceptable.
- Never use steel or copper wire in place of fuse.
- Do not install working light, radio set, etc. on machine which is not provided with reserve power supply.
- Do not install accessories if fuse capacity of reserve power supply is exceeded.

(1) Fuse

(2) Fusible Link

W1012092

[4] CONNECTOR

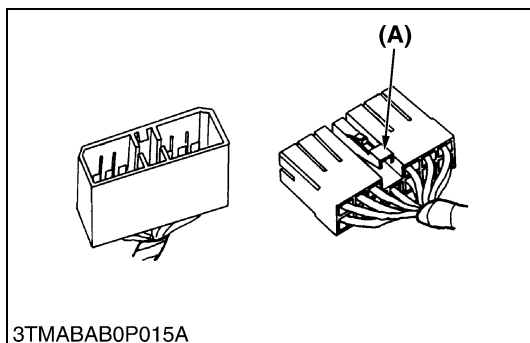

- For connector with lock, push lock to separate.

(A) Push

W1012211

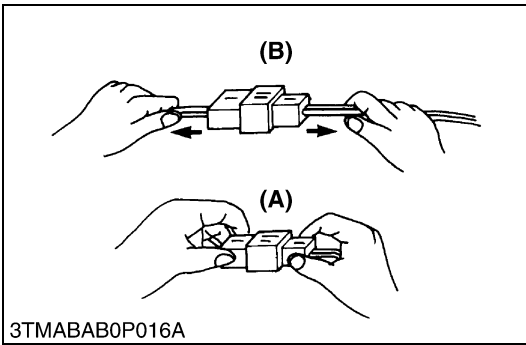

- In separating connectors, do not pull wire harnesses.
- Hold connector bodies to separate.

(A) Correct

(B) Incorrect

W1012272

4. LUBRICANTS, FUEL AND COOLANT

	Place	Capacity		Lubricants, fuel and coolant
		L2800	L3400	
1	Fuel	34 L 9.0 U.S.gals 7.4 Imp.gals		No. 2-D diesel fuel No. 1-D diesel fuel if temperature is below -10 °C (14 °F)
2	Coolant	6.0 L 6.3 U.S.qts 5.3 Imp.qts		Fresh clean water with anti-freeze
	Recovery tank	0.6 L 0.63 U.S.qts 0.53 Imp.qts		
3	Engine crankcase (with filter)	5.7 L 6.0 U.S.qts 5.0 Imp.qts		Engine oil: API service classification CD, CE or CF Below 0 °C (32 °F) : SAE10W, 10W-30 or 10W-40 0 to 25 °C (32 to 77 °F): SAE20, 10W-30 or 10W-40 Above 25 °C (77 °F): SAE30, 10W-30 or 10W-40
4	Transmission case (2WD)	27 L 7.1 U.S.gals 5.9 Imp.gals		KUBOTA UDT or SUPER UDT fluid*
	Transmission case (4WD)	27.5 L 7.3 U.S.gals 6.1 Imp.gals		
	Transmission case (HST (4WD))	23.5 L 6.2 U.S.gals 5.2 Imp.gals		
5	Front axle case (4WD)	4.5 L 4.8 U.S.qts 3.9 Imp.qts		KUBOTA UDT or SUPER UDT fluid* or SAE80 - SAE 90 gear oil
Greasing				
	Place	No. of greasing point	Capacity	Type of grease
6	Front wheel hub	2 [2WD only]	A small amount	Bearing grease
	Knuckle shaft	2 [2WD only]	Until grease overflows	Multipurpose type grease
	Front axle support	2		
	Clutch pedal	1		
	Brake pedal	1		
	Pedal shaft	1		
	Top link bracket	2 [with draft control (if equipped)]		
	Battery terminal	2		
	Lift rod	1		

* KUBOTA original transmission hydraulic fluid.

■ NOTE

- **Engine Oil:**
Oil used in the engine should have an American Petroleum Institute (API) service classification and Proper SAE Engine Oil according to the ambient temperatures as shown above:
- With the emission control now in effect, the CF-4 and CG-4 lubricating oils have been developed for use of a low-sulfur fuel on on-road vehicle engines. When an off-road vehicle engine runs on a high-sulfur fuel, it is advisable to employ the CF, CD or CE lubricating oil with a high total base number. If the CF-4 or CG-4 lubricating oil is used with a high-sulfur fuel, change the lubricating oil at shorter intervals.
- Lubricating oil recommended when a low-sulfur or high-sulfur fuel employed.

5. TIGHTENING TORQUES

[1] GENERAL USE SCREWS, BOLTS AND NUTS

Screws, bolts and nuts whose tightening torques are not specified in this Workshop Manual should be tightened according to tables below.

Indication on top of bolt	4 No-grade or 4T						7 7T						9 9T		
Material of bolt	SS400, S20C						S43C, S48C						SCr435, SCM435		
Material of opponent part	Ordinariness			Aluminum			Ordinariness			Aluminum			Ordinariness		
Unit	N-m	kgf-m	ft-lbs	N-m	kgf-m	ft-lbs	N-m	kgf-m	ft-lbs	N-m	kgf-m	ft-lbs	N-m	kgf-m	ft-lbs
Diameter															
M6 (6 mm, 0.24 in.)	7.85 to 9.31	0.80 to 0.95	5.79 to 6.87	7.85 to 8.82	0.80 to 0.90	5.79 to 6.50	9.81 to 11.2	1.00 to 1.15	7.24 to 8.31	7.85 to 8.82	0.80 to 0.90	5.79 to 6.50	12.3 to 14.2	1.25 to 1.45	9.05 to 10.4
M8 (8 mm, 0.31 in.)	17.7 to 20.5	1.8 to 2.1	13.1 to 15.1	16.7 to 19.6	1.7 to 2.0	12.3 to 14.4	23.6 to 27.4	2.4 to 2.8	17.4 to 20.2	17.7 to 20.5	1.8 to 2.1	13.1 to 15.1	29.5 to 34.3	3.0 to 3.5	21.7 to 25.3
M10 (10 mm, 0.39 in.)	39.3 to 45.1	4.0 to 4.6	29.0 to 33.2	31.4 to 34.3	3.2 to 3.5	23.2 to 25.3	48.1 to 55.8	4.9 to 5.7	35.5 to 41.2	39.3 to 44.1	4.0 to 4.5	29.0 to 32.5	60.9 to 70.6	6.2 to 7.2	44.9 to 52.0
M12 (12 mm, 0.47 in.)	62.8 to 72.5	6.4 to 7.4	46.3 to 53.5	-	-	-	77.5 to 90.2	7.9 to 9.2	57.2 to 66.5	62.8 to 72.5	6.4 to 7.4	46.3 to 53.5	103 to 117	10.5 to 12.0	76.0 to 86.7
M14 (14 mm, 0.55 in.)	108 to 125	11.0 to 12.8	79.6 to 92.5	-	-	-	124 to 147	12.6 to 15.0	91.2 to 108	-	-	-	167 to 196	17.0 to 20.0	123 to 144
M16 (16 mm, 0.63 in.)	167 to 191	17.0 to 19.5	123 to 141	-	-	-	197 to 225	20.0 to 23.0	145 to 166	-	-	-	260 to 304	26.5 to 31.0	192 to 224
M18 (18 mm, 0.71 in.)	246 to 284	25.0 to 29.0	181 to 209	-	-	-	275 to 318	28.0 to 32.5	203 to 235	-	-	-	344 to 402	35.0 to 41.0	254 to 296
M20 (20 mm, 0.79 in.)	334 to 392	34.0 to 40.0	246 to 289	-	-	-	368 to 431	37.5 to 44.0	272 to 318	-	-	-	491 to 568	50.0 to 58.0	362 to 419

W1034542

6. MAINTENANCE

No.	Item	Period	Indication on hour meter													After since	Reference page		
			50	100	150	200	250	300	350	400	450	500	550	600	650				700
1	Engine oil	Change	★	☆		☆		☆		☆		☆		☆		☆	every 100 Hr	G-14	
2	Engine oil filter	Replace	★			☆				☆				☆			every 200 Hr	G-14	
3	Hydraulic oil filter	Replace	★			☆				☆				☆			every 200 Hr	G-17	
4	HST oil filter	Replace	★			☆				☆				☆			every 200 Hr	G-18	
5	Transmission fluid	Change	★							☆							every 400 Hr	G-15, 16	
6	Front axle case oil (4WD)	Change	★							☆							every 400 Hr	G-19	
7	Front axle pivot	Adjust												☆			every 600 Hr	G-33	
8	Greasing	—	☆	☆	☆	☆	☆	☆	☆	☆	☆	☆	☆	☆	☆	☆	every 50 Hr	G-21	
9	Engine start system	Check	☆	☆	☆	☆	☆	☆	☆	☆	☆	☆	☆	☆	☆	☆	every 50 Hr	G-22, 23	
10	Wheel bolt torque	Check	☆	☆	☆	☆	☆	☆	☆	☆	☆	☆	☆	☆	☆	☆	every 50 Hr	G-24	
11	Battery condition	Check		☆		☆		☆		☆		☆		☆		☆	every 100 Hr	G-28	*5
12	Air cleaner element	Clean		☆		☆		☆		☆		☆		☆		☆	every 100 Hr	G-25	@ *1
		Replace															every 1 year	G-25	@ *2
13	Fuel filter element	Clean		☆		☆		☆		☆		☆		☆		☆	every 100 Hr	G-26	@
		Replace								☆							every 400 Hr	G-26	@
14	Fan belt	Adjust		☆		☆		☆		☆		☆		☆		☆	every 100 Hr	G-26	
15	Clutch	Adjust	★	☆		☆		☆		☆		☆		☆		☆	every 100 Hr	G-19, 20	
16	Brake	Adjust		☆		☆		☆		☆		☆		☆		☆	every 100 Hr	G-27	
17	Radiator hose and clamp	Check				☆				☆				☆			every 200 Hr	G-30	
		Replace															every 2 years	G-30	
18	Power steering oil line	Check				☆				☆				☆			every 200 Hr	G-31	
		Replace															every 2 years	G-31	
19	Fuel line	Check		☆		☆		☆		☆		☆		☆		☆	every 100 Hr	G-27	@
		Replace															every 2 years	G-27	@ *3
20	HST oil line	Check				☆				☆				☆			every 200 Hr	G-31	
		Replace															every 2 years	G-31	

W1035769

No.	Item	Period	Indication on hour meter													After since	Reference page			
			50	100	150	200	250	300	350	400	450	500	550	600	650					700
21	Toe-in	Adjust				☆				☆				☆			every 200 Hr	G-32		
22	Intake air line	Check				☆				☆				☆			every 200 Hr	G-31	@	
		Replace															every 2 years	G-31		*3
23	Greasing (2WD front wheel hub)	-								☆							every 400 Hr	G-32		
24	Engine valve clearance	Adjust															every 800 Hr	1-S12		*4
25	Fuel injection nozzle injection pressure	Check															every 1500 Hr	1-S18	@	*4
26	Injection pump	Check															every 3000 Hr	1-S17	@	*4
27	Cooling system	Flush															every 2 years	G-34, 35, 36		
28	Coolant	Change															every 2 years	G-34, 35, 36		
29	Fuel system	Bleed																G-38		
30	Clutch housing water	Drain																G-38		
31	Fuse	Replace																G-39		
32	Light bulb	Replace																G-39		

W1029476

■ IMPORTANT

- The jobs indicated by ★ must be done after the first 50 hours of operation.
- *1 : Air cleaner should be cleaned more often in dusty conditions than in normal conditions.
- *2 : Every year or every 6 times of cleaning.
- *3 : Replace only if necessary.
- *4 : Consult your local KUBOTA distributor for this service.
- *5 : When the battery is used for less than 100 hours per year, check the battery condition by reading the indication annually.
- The items listed above (@ marked) are registered as emission related critical parts by KUBOTA in the U.S.EPA nonroad emission regulation. As the engine owner, you are responsible for the performance of the required maintenance on the engine according to the above instruction. Please see the Warranty Statement in detail.

7. CHECK AND MAINTENANCE



CAUTION

- Be sure to check and service the tractor on a flat place with engine shut off, the parking brake on and chock the wheels.

[1] DAILY CHECK

To prevent trouble from occurring, it is important to know the condition of the tractor. Check the following items before starting.

Checking

- Check areas where previous trouble was experienced.
- Walk around the machine.
 1. Check the tire pressure, and check for wear and damage.
 2. Check for oil and water leak.
 3. Check the engine oil level.
 4. Check the transmission fluid level.
 5. Check the coolant level.
 6. Check the condition of seat belt and ROPS attaching hardware.
 7. Check and clean the radiator screen and grill.
 8. Check the nuts of tires are tight.
 9. Care of danger, warning and caution labels.
 10. Clean around the exhaust manifold and the muffler of the engine.
- While sitting in the operator's seat.
 1. Check the brake pedals and clutch pedal.
 2. Check the parking brake.
 3. Check the steering wheel.
- Turning the key switch.
 1. Check the performance of the easy checker lights.
 2. Check the lights, turn signal lights, hazard lights and other light equipment. Clean if necessary.
 3. Check the performance of the meters and gauges.
- Starting the engine.
 1. Check to see that the lights on the easy checker go off.
 2. Check the color of the exhaust gas.
 3. Check the brakes for proper operation.

[2] CHECK POINTS OF INITIAL 50 HOURS

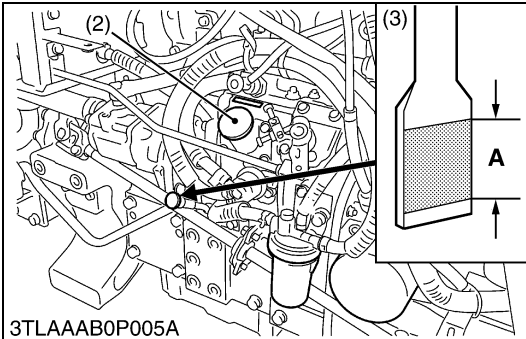
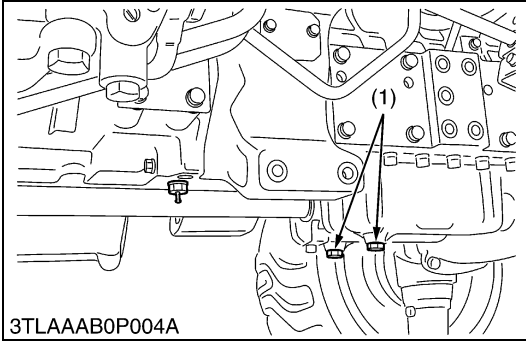

Changing Engine Oil

⚠ CAUTION

- **Before changing oil, be sure to stop the engine.**
- 1. Start and warm up the engine for approx. 5 minutes.
- 2. Place an oil pan underneath the engine.
- 3. To drain the used oil, remove the drain plug (1) at the bottom of the engine and drain the oil completely.
- 4. Screw in the drain plug (1).
- 5. Fill new oil up to upper line on the dipstick (3).

■ IMPORTANT

- **When using an oil of different manufacture or viscosity from the previous one, remove all of the old oil.**
- **Never mix two different types of oil.**
- **Use the proper SAE Engine Oil according to ambient temperatures.**
- **Refer to "LUBRICANTS, FUEL AND COOLANT". (See page G-7.)**

Engine oil	Capacity	5.7 L 6.0 U.S.qts 5.0 Imp.qts

- (1) Drain Plug
(2) Oil Inlet Plug
(3) Dipstick

A : Oil level is acceptable within this range.

W1014533

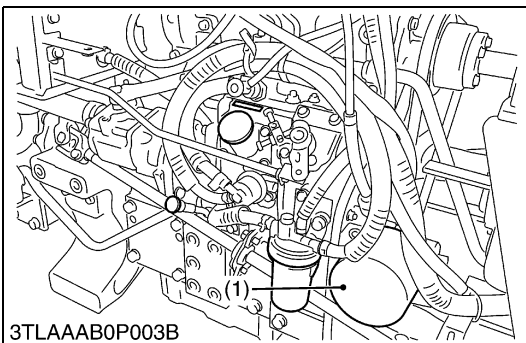

Replacing Engine Oil Filter Cartridge

⚠ CAUTION

- **Be sure to stop the engine before changing oil filter cartridge (1).**
- **Allow engine to cool down sufficiently, oil can be hot and can burn.**
- 1. Remove the engine oil filter cartridge (1).
- 2. Put a film of clean engine oil on rubber seal of new filter.
- 3. Tighten the filter quickly until it contacts the mounting surface. Tighten filter by hand an additional 1/2 turn only.
- 4. After the new filter has been replaced, the engine oil normally decreases a little. Make sure that the engine oil does not leak through the seal and be sure to check the oil level on the dipstick. Then, replenish the engine oil up to the prescribed level.

■ IMPORTANT

- **To prevent serious damage to the engine, replacement element must be highly efficient. Use only a KUBOTA genuine filter.**

- (1) Engine Oil Filter Cartridge

W1014892

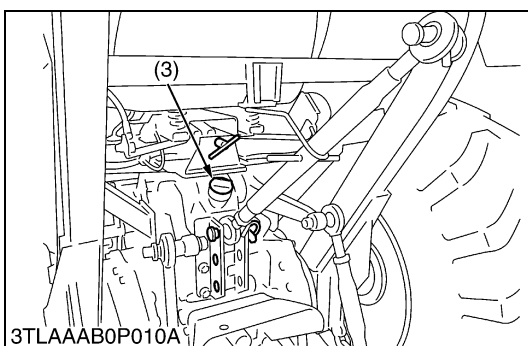
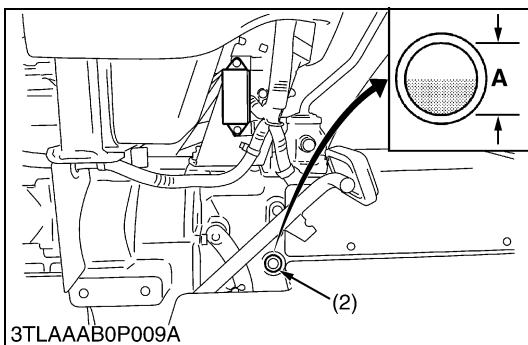
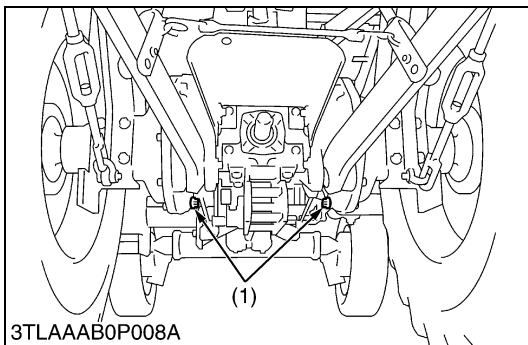
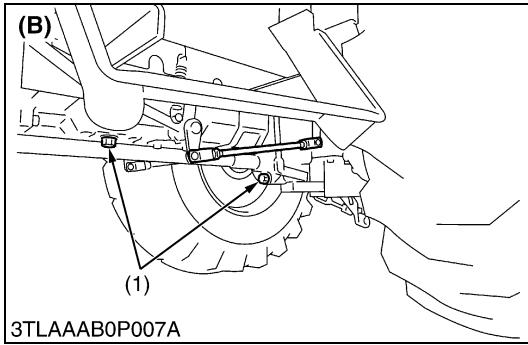
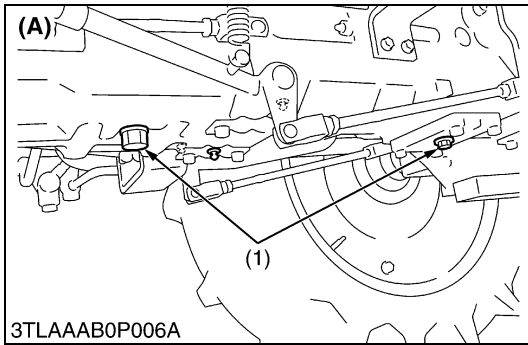

Changing Transmission Fluid (Manual Transmission Type)

CAUTION

- Be sure to stop the engine before checking and changing the transmission fluid.
- 1. Place an oil pan underneath the transmission case.
- 2. Remove the drain plugs (1) at the bottom of the transmission case.
- 3. Drain the transmission fluid.
- 4. After draining, screw in the drain plugs (1).
- 5. Fill with the new KUBOTA SUPER UDT fluid up to the upper line of the gauge (2).
- 6. After running the engine for a few minutes, stop it and check the fluid level again, if low, add fluid prescribed level (A).

IMPORTANT

- Use only multi-grade transmission fluid. Use of other fluids may damage the transmission or hydraulic system.
- Refer to "LUBRICANTS, FUEL AND COOLANT". (See page G-7.)
- Never work the tractor immediately after changing the transmission fluid. Keeping the engine at medium speed for a few minutes to prevent damage to the transmission.
- Do not mix different brands oil together.

Transmission fluid	Capacity	2WD	27 L 7.1 U.S.gals 5.9 Imp.gals
		4WD	27.5 L 7.3 U.S.gals 6.1 Imp.gals

- (1) Drain Plug
- (2) Gauge
- (3) Filling Plug

A : Oil level is acceptable within this range.
 (A) 2WD Type
 (B) 4WD Type

W1015055

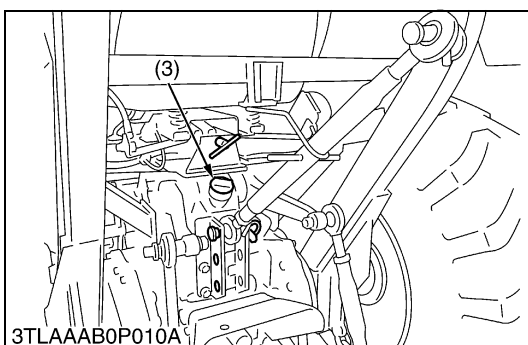
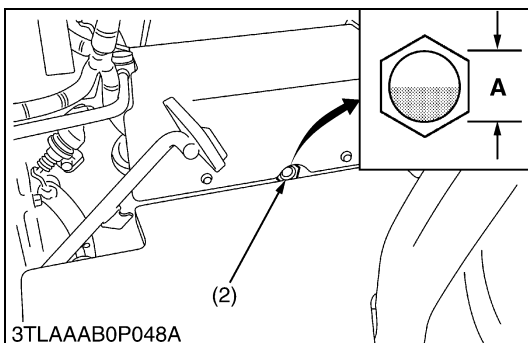
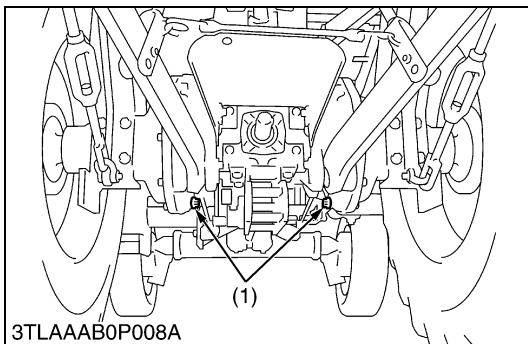
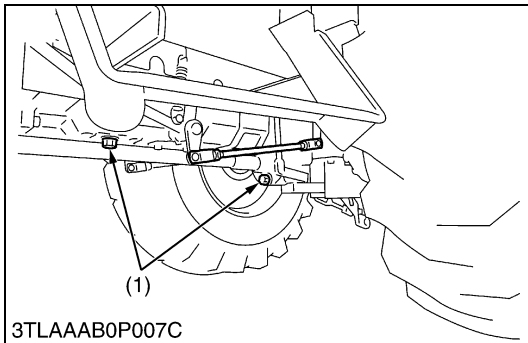

Changing Transmission Fluid (HST Type)

⚠ CAUTION

- **Be sure to stop the engine before checking and changing the transmission fluid.**
1. Place an oil pan underneath the transmission case.
 2. Remove the drain plugs (1) at the bottom of the transmission case.
 3. Drain the transmission fluid.
 4. After draining, screw in the drain plugs (1).
 5. Fill with the new KUBOTA SUPER UDT fluid up to the upper line of the gauge (2).
 6. After running the engine for a few minutes, stop it and check the fluid level again, if low, add fluid prescribed level (A).

■ IMPORTANT

- **Use only multi-grade transmission fluid. Use of other fluids may damage the transmission or hydraulic system.**
- **Refer to "LUBRICANTS, FUEL AND COOLANT". (See page G-7.)**
- **Never work the tractor immediately after changing the transmission fluid. Keeping the engine at medium speed for a few minutes to prevent damage to the transmission.**
- **Do not mix different brands oil together.**

Transmission fluid	Capacity	
		23.5 L
		6.2 U.S.gals
		5.2 Imp.gals

- (1) Drain Plug
- (2) Gauge
- (3) Filling Plug

A : Oil level is acceptable within this range.

W1031890

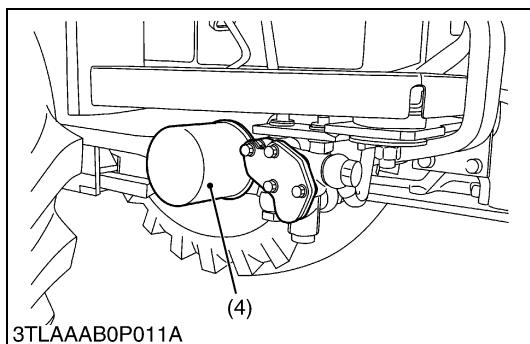
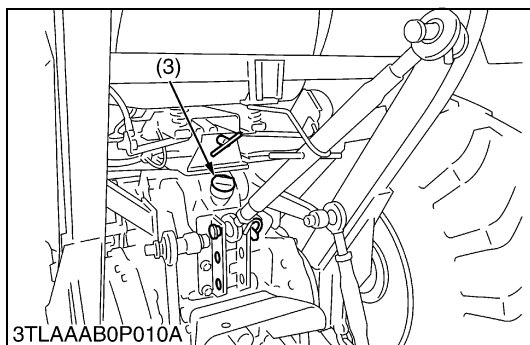
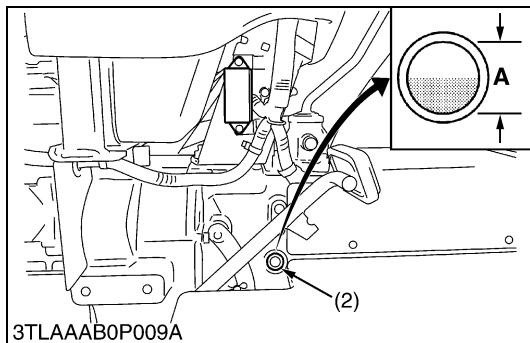
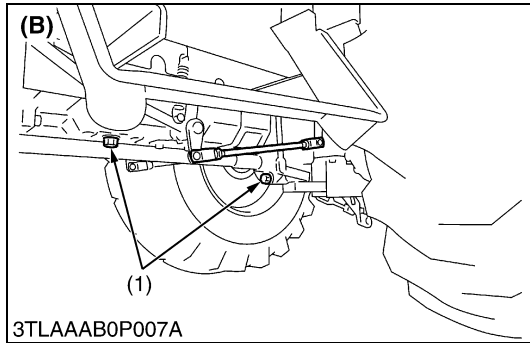
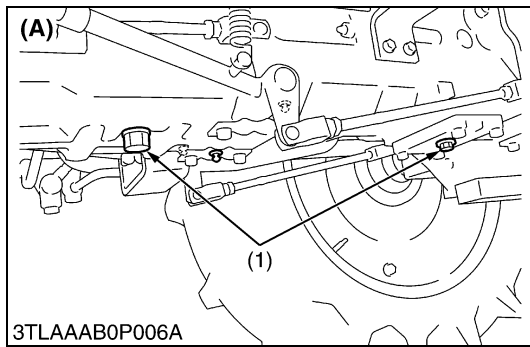

Replacing Hydraulic Oil Filter (Manual Transmission Type)

⚠ CAUTION

- Be sure to stop the engine before changing the oil filters.
 - Allow engine to cool down sufficiently, oil can be hot and can burn.
1. Place an oil pan under the tractor.
 2. Remove the drain plugs (1) at the bottom of the transmission case.
 3. Drain the transmission fluid.
 4. After draining, screw in the drain plugs.
 5. Remove the oil filter cartridge (4) by using a filter wrench.
 6. Make sure the mounting surface is clean.
Put a film of clean transmission fluid on the rubber seal of the new filter.
 7. Install the new filter cartridge.
 8. Quickly tighten the filter until it contacts the mounting surface, then tighten it by hand an additional 1/2 turn only.
 9. After the new filter have been replaced, fill with oil up to the upper line of the gauge (2).
 10. After running the engine for a few minutes, stop it and recheck the oil level, add oil to the prescribed level.
 11. Make sure that the transmission fluid doesn't leak through the seal of the filter.

■ IMPORTANT

- To prevent serious damage to the hydraulic system. Use only a genuine KUBOTA filter or its equivalents.

- (1) Drain Plug
 (2) Gauge
 (3) Filling Plug
 (4) Hydraulic Oil Filter

- A : Oil level is acceptable within this range.
 (A) 2WD Type
 (B) 4WD Type

W1015586

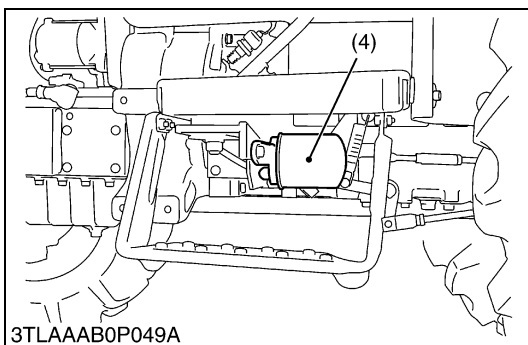
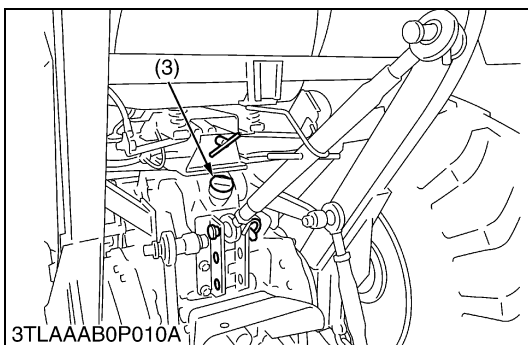
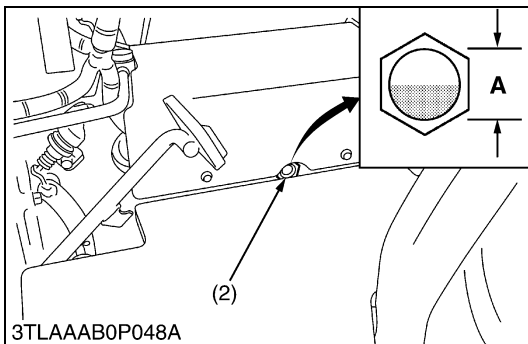
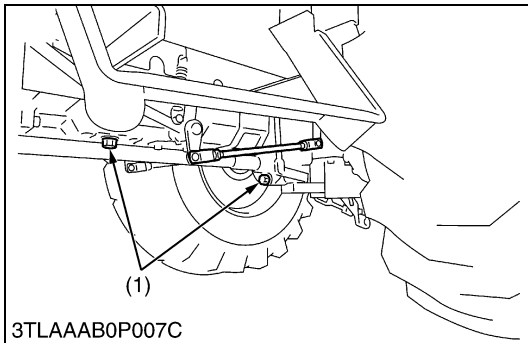

Replacing Hydraulic Oil Filter (HST Type)

⚠ CAUTION

- Be sure to stop the engine before changing the oil filters.
- Allow engine to cool down sufficiently, oil can be hot and can burn.

1. Place an oil pan under the tractor.
2. Remove the drain plugs (1) at the bottom of the transmission case.
3. Drain the transmission fluid.
4. After draining, screw in the drain plugs.
5. Remove the oil filter cartridge (4) by using a filter wrench.
6. Make sure the mounting surface is clean.
Put a film of clean transmission fluid on the rubber seal of the new filter.
7. Install the new filter cartridge.
8. Quickly tighten the filter until it contacts the mounting surface, then tighten it by hand an additional 1/2 turn only.
9. After the new filter have been replaced, fill with oil up to the upper line of the gauge (2).
10. After running the engine for a few minutes, stop it and recheck the oil level, add oil to the prescribed level.
11. Make sure that the transmission fluid doesn't leak through the seal of the filter.

■ IMPORTANT

- To prevent serious damage to the hydraulic system. Use only a genuine KUBOTA filter or its equivalents.

- (1) Drain Plug
 (2) Gauge
 (3) Filling Plug
 (4) Hydraulic Oil Filter

A : Oil level is acceptable within this range.

W1034395

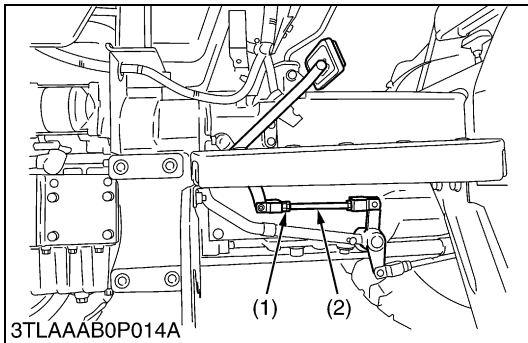
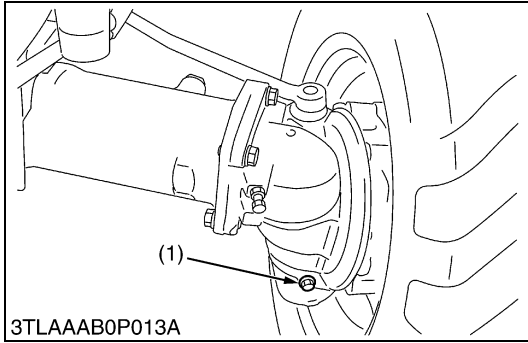
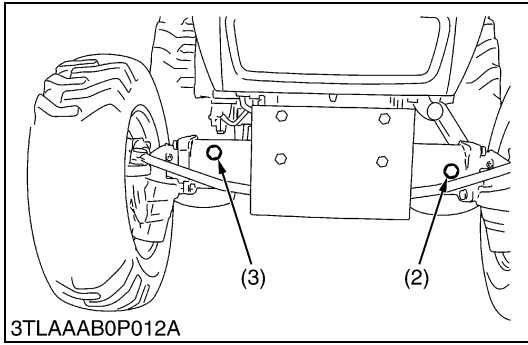

Changing Front Axle Case Oil [4WD Type]

1. Place the oil pans underneath the front axle case.
2. Remove the drain plug (1) both sides and filling port plug (3) to drain the oil.
3. After draining, reinstall the drain plug.
4. Remove the oil level check plug (2).
5. Fill with the new oil up to the check plug (2) port.
6. After filling, reinstall the check plug (2) and filling port plug.

■ IMPORTANT

- Use KUBOTA SUPER UDT fluid or SAE 80, 90 gear oil. Refer to "LUBRICANTS, FUEL AND COOLANT". (See page G-7.)

Front axle case oil	Capacity	4.5 L 4.8 U.S.qts 3.9 Imp.qts
---------------------	----------	-------------------------------------

- (1) Drain Plug (2) Check Plug (3) Filling Port Plug

W1030064

Adjusting Clutch Pedal Free Travel (L2800)

1. Stop the engine and remove the key.
2. Slightly depress the clutch pedal and measure free travel at top of pedal stroke.
3. If adjustment is needed, loosen the lock nut (1), and turn the turnbuckle (2) to adjust the clutch pedal free travel within factory specification.
4. Retighten the lock nut (1).

Clutch pedal free travel	Factory spec.	20 to 30 mm 0.8 to 1.2 in.
--------------------------	---------------	-------------------------------

- (1) Lock Nut (2) Turnbuckle

W1044872

Please click here and go
back to our website.

BUY NOW

**Then Instant Download the
Complete Manual.**

Thank you very much!