

Laboratory – 1

AC Circuits

Phasors and Impedance

Transformers

Objectives

The objectives of this laboratory are to gain practical understanding and experience of AC circuits by

- studying and measuring voltages and currents in series RC, RL and RLC circuits,
- calculating and measuring impedance,
- measuring and graphing phasors and phase shift between voltage and current,
- observing impedance change as a function of changing the frequency of the applied source.

Background

Who needs AC circuits? Sophomores majoring in electrical and computer engineering have their own ideas about this. So did prominent physicist and engineers in the late 1800s. DC was in the market place at that time. It was used, although to a limited extent, for power distribution. Some engineers wanted to continue to use DC: others believed that AC was easier to generate and distribute. As we know AC won the battle, so to speak. The decision to use AC was based primarily on the generation and efficiency of distributing AC power, particularly over long distances.

The Nature of AC:

The term AC is literally an abbreviation for alternating current. We do not need to take this to heart. When one uses the term “AC current” one is actually saying alternating current, current. When we encounter the term AC we should accept it as a “handle” for sinusoidal waveform. An AC voltage might be defined by,

$$v(t) = V\sin(\omega t) \qquad \text{Eq. 1.1}$$

We are familiar with the nature of this function from our math courses. Electrical and computer engineers become extremely familiar with this signal because not only is it the dominant signal of AC circuits, it is the basic signal in communications, signal processing and waveforms in general. We have learned from Fourier series that any periodic signal can be represented by an infinite series formed from sine and cosine terms of various magnitudes and frequencies.

What is the implication of a sinusoidal voltage or current? Consider a sinusoidal waveform as shown in Figure 1.1. The magnitude of the function varies between +150 and -150 volts at a frequency of 60 H (hertz). The frequency of all power distribution systems in the United States is 60 Hz. In most of Europe and the Country of Japan the frequency of the power system is 50 Hz.

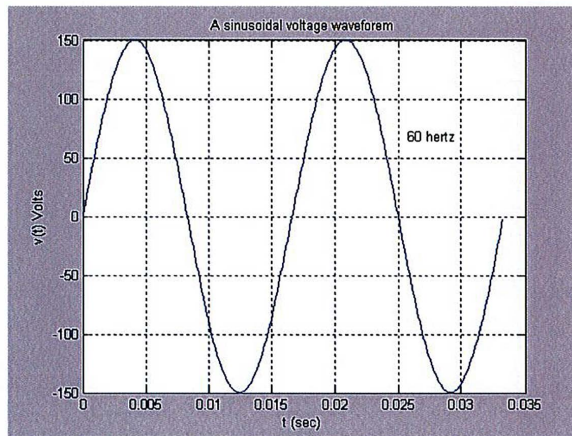

Figure 1.1: A sinusoidal voltage waveform.

We recall that t (time, in seconds), f (frequency, in hertz) and ω (radian frequency, in rad/sec) are related by,

$$\omega = 2\pi f, \quad f = \frac{1}{T}, \quad T = \text{period} \quad \text{Eq. 1.2}$$

The implication of a 60 hertz sine wave voltage is that the polarity of the voltage changes from positive to negative, 60 times per second. The implication of a 60 hertz current is that the electrons are changing direction 60 times per second. Try moving your finger back and forth 60 times per second! Think about electrons changing direction at 3,000,000,000 times per second, the speed of today's PCs: Blows your mind. The salvation here is that we only must move electrons and they do not weight much. Having said all this, let us take a look at what goes on in an AC circuit.

The AC Circuit:

Consider the RLC circuit shown in Figure 1.2. We write KVL around the circuit.

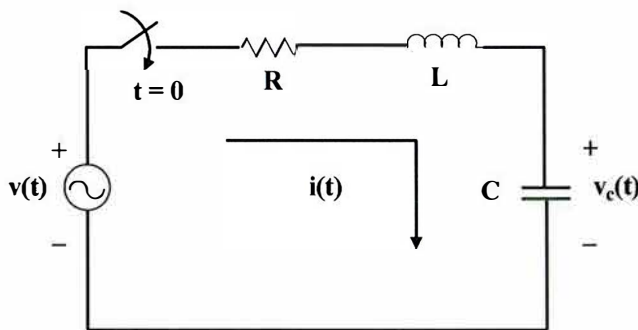

Figure 1.2: An RLC circuit.

$$v(t) = ri(t) + L \frac{di(t)}{dt} + v_c(t) \quad \text{Eq. 1.3}$$

using,

$$i(t) = C \frac{dv_c(t)}{dt} \quad \text{Eq. 1.4}$$

gives

$$\frac{d^2v_c(t)}{dt^2} + \frac{L}{R} \frac{dv_c(t)}{dt} + \frac{v_c(t)}{RC} = \frac{v(t)}{RC} \quad \text{Eq. 1.5}$$

Equation 1.5 is a linear, constant coefficient, second order differential equation. We have seen this equation in our study of transients. Although methods of solving this equation are well known, that does not make it a simple problem, especially if the characteristic equation has complex roots. A typical waveform of the capacitor voltage for a 60 hertz input signal is shown in Figure 1.3. The transient is quickly over. The good news is that we only need to solve the steady state portion of the

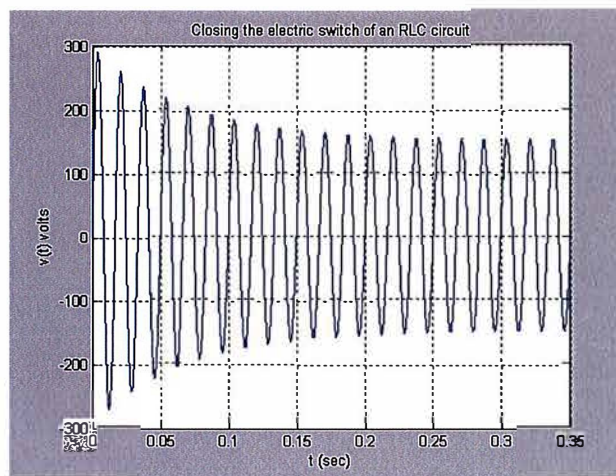

Figure 1.3: Typical response of a RLC circuit with a sinusoidal input.

differential equation. This makes the math much easier. Reasoning along will tell us that if we apply a sinusoidal signal as the forcing function of the differential equation in Equation 1.5, the steady state will also be a sinusoid of the form given in Equation 1.6. We only need to solve for K and θ and we have the steady state solution.

$$v_c(t)_{steady\ state} = K \cos(\omega t + \theta) \quad \text{Eq. 1.6}$$

A German-Austrian mathematician and engineer, C. P. Steinmetz, 1865-1923, migrated to America and worked for General Electric. He liked to smoke cigars on the shop floor of GE much to the consternation of GE management. When asked not to smoke on the production floor, the legend has it that he made the statement, “no cigar, no Steinmetz.” He was a very intelligent man: very important to the company. So he continued to smoke his cigars on the shop floor!

Steinmetz introduced the concept of solving for K and θ by using *phasors*. The detailed background for phasors is found in any basic circuits text. We only consider the essentials here.

To solve an AC circuit for steady state we use the following:

Applied voltages of the form $V_m \cos(\omega t + \theta)$ are replaced by $\longrightarrow V = V_m \angle \theta$

For circuit elements;

R is replaced by R; L is replaced by $\longrightarrow j\omega L$ C is replaced by $\longrightarrow \frac{-j}{\omega C}$

For AC circuit analysis, Figure 1.2 becomes

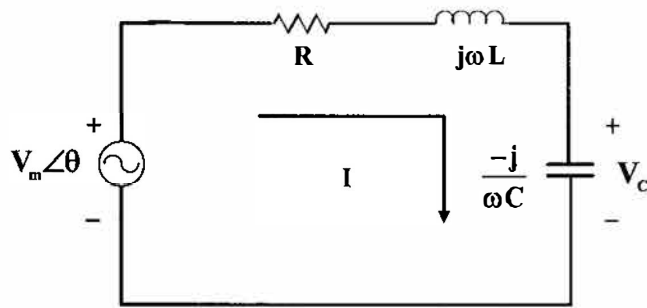

Figure 1.4: Circuit for AC steady state analysis.

Let the input voltage be $100 \cos(2\pi 60t + 30^\circ)$. Let $R = 100 \Omega$, $L = 0.25 \text{ H}$, $C = 10 \mu\text{F}$.

We note that $\omega = 2\pi 60 = 377$. This is used in finding $j\omega L$ and $1/j\omega C$. The circuit of Figure 1.4, with values added, is shown in Figure 1.5.

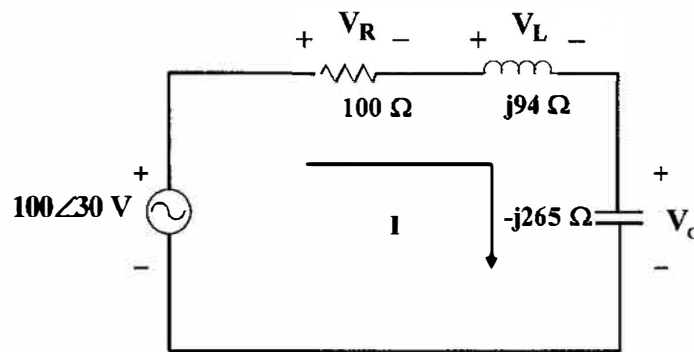

Figure 1.5: Series AC circuit.

The solution for the phasor current I is given by

$$I = \frac{100 \angle 30^\circ}{100 + j94 - j265} = \frac{100 \angle 30^\circ}{198 \angle -60^\circ} = 0.51 \angle 90^\circ \text{ A} \quad \text{Eq. 1.7}$$

The current in the time domain is given by,

$$i(t) = 0.51 \cos(377t + 90^\circ) \text{ A} \quad \text{Eq. 1.8}$$

The capacitor voltage, as a phasor, is (using voltage division adapted to AC circuits),

$$V_c = \frac{(100 \angle 30^\circ)(-j265)}{100 + j94 - j265} = 133.8 \angle -0.3^\circ \text{ V} \quad \text{Eq. 1.9}$$

V_c contains all the information we need to write $v_c(t)$. Knowing the magnitude and phase of V_c allows us to write $v_c(t) = 133.8 \cos(377t - 0.3^\circ) \text{ V}$. In most cases we are never interested in the time domain solution of AC voltages and currents. Phasors give us all the information we need for practically all AC circuit.

The Impedance Concept:

The impedance of a circuit is a by-product of the method of undetermined coefficients that is used in solving for the steady state solution of a differential equation. Fortunately, all the rules we learned about resistance in DC circuits carry over to impedance in AC circuits. Impedance, in general, is a complex number composed of a real part and a j (imaginary) part. We write impedance as

$$Z = R + jX \quad \text{Eq. 1.10}$$

Z has units of ohms. X (called reactance) can be either a positive or negative number. It also has units of ohms. Consider the circuit below that is expressed with Z 's.

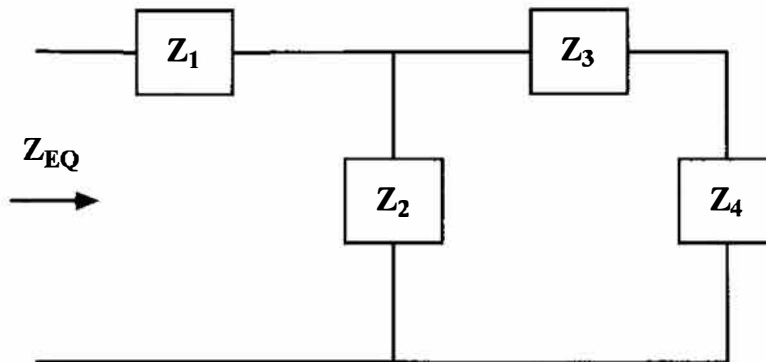

Figure 1.6: Finding impedance of an AC circuit.

The Z_{EQ} is given by,

$$Z_{EQ} = Z_1 + \frac{Z_2(Z_3 + Z_4)}{Z_2 + Z_3 + Z_4} \quad \text{Eq. 1.11}$$

We see that the impedance is calculated just as we calculated resistance. There are two major differences between resistance and impedance. First, impedance has both a real part and a j part. Resistance has only a real part. Second, resistance does not change as the frequency of the applied voltage (or applied current) changes. The value of impedance does change as a function of the frequency of the applied voltage or current sources. This makes a world of difference in how circuits perform.

Basic AC Circuit Properties:

Two of the most basic properties of DC circuits were the *current splitting rule* and the *voltage division rule*. These rules (properties) carry over to AC circuits with modifications to accommodate impedance and phasors. This is illustrated in the following example. We desire to find the phasor current I shown in the circuit Figure 1.7. First determine the impedance seen by the source:

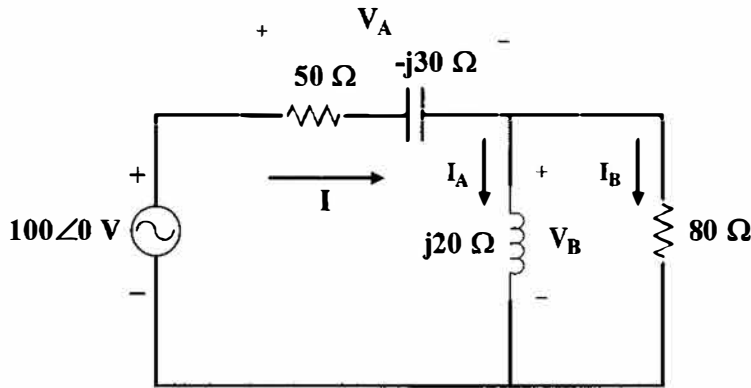

Figure 1.7: AC circuit for example problem.

$$Z = 50 - j30 + \frac{80(j20)}{80 + j20} = 55.8 \angle -11.6^\circ \Omega \tag{Eq. 1.12}$$

Therefore, the phasor current I is,

$$I = \frac{100 \angle 0^\circ}{55.8 \angle -11.6^\circ} = 1.79 \angle 11.6^\circ A \tag{Eq. 1.13}$$

If we want to find the currents I_A and I_B we can use the *current splitting rule*, in the same format as for resistive circuits. Therefore,

$$I_A = \frac{(1.79 \angle 11.6^\circ)(80)}{(80 + j20)} = 1.736 \angle -2.44^\circ A \tag{Eq. 1.14}$$

$$I_B = \frac{(1.79 \angle 11.6^\circ)(j20)}{(80 + j20)} = 0.434 \angle 87.6^\circ A \tag{Eq. 1.15}$$

We know that

$$I = I_A + I_B \quad \text{Eq. 1.16}$$

Substituting the values in Equations 1.14 and 1.15 will give the value of I in Equation 1.13. If we want to find voltages V_A and V_B we can use the *voltage division rule* in the same format as used for DC circuits. Therefore,

$$V_A = \frac{(100\angle 0^\circ)(50 - j30)}{50 - j30 + \frac{80(j20)}{80 + j20}} = 104.4\angle -19.4^\circ \text{ V} \quad \text{Eq. 1.17}$$

and

$$V_B = \frac{100\angle 0^\circ \left[\frac{80(j20)}{80 + j20} \right]}{50 - j30 + \frac{80(j20)}{80 + j20}} = 34.8\angle 87.6^\circ \text{ V} \quad \text{Eq. 1.18}$$

By Kirchoff's voltage law we know

$$V = V_A + V_B = (104\angle -19.4^\circ) + (34.8\angle 87.6^\circ) = 100\angle 0^\circ \text{ V (check)} \quad \text{Eq. 1.19}$$

We can also apply mesh analysis and nodal analysis to AC circuits much in the same manner that we did for DC circuits. We illustrate this with a mesh analysis problem. Consider the circuit shown in Figure 1.8.

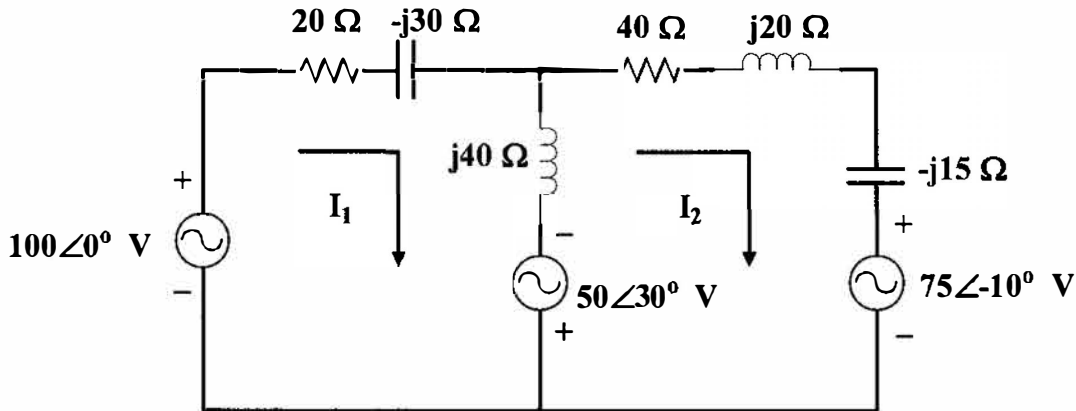

Figure 1.8: Circuit to illustrate AC circuit mesh analysis.

We can write the following mesh equations.

For mesh 1:

$$(20 - j30 + j40)I_1 - j40I_2 = 100\angle 0^\circ + 50\angle 30^\circ \quad \text{Eq. 1.20}$$

For mesh 2:

$$-j40I + (40 + j20 - j15 + j40)I_2 = -50\angle 30^\circ - 75\angle -10^\circ \quad \text{Eq. 1.21}$$

These equations can be simplified and placed in matrix form as follows:

$$\begin{bmatrix} (20 + j10) & -j40 \\ -j40 & (40 + j45) \end{bmatrix} \begin{bmatrix} I_1 \\ I_2 \end{bmatrix} = \begin{bmatrix} 145.5\angle 99^\circ \\ 117.8\angle -174.2^\circ \end{bmatrix} \quad \text{Eq. 1.22}$$

One can easily solve for the phasor currents I_1 and I_2 from Equation 1.22.

Phasor Diagrams:

All along we have been working with phasor voltages and phasor currents. Phasors have magnitude and angle. One might think that a phasor is a vector. This is not the case. For one thing, voltage is not a vector but rather a scalar. We cannot apply curl, divergence, and dot product to voltages and get other voltages. A phasor is a way of expressing complex number that represent voltages and currents.

Earlier we saw how

$$V = V_A + V_B \quad \text{and} \quad I = I_1 + I_2 \quad \text{Eq. 1.23}$$

were treated as phasors, analytically, and added to obtain a resultant voltage or current.

We can also add phasor voltages and phasor currents graphically. We do this exactly the same as if we were adding vectors in statics and dynamics. When we do so, the result is a phasor diagram. Phasor diagrams are useful in helping us understand what is taking place in an electric circuit or even a power distribution system.

We consider again the series RLC AC circuit shown below.

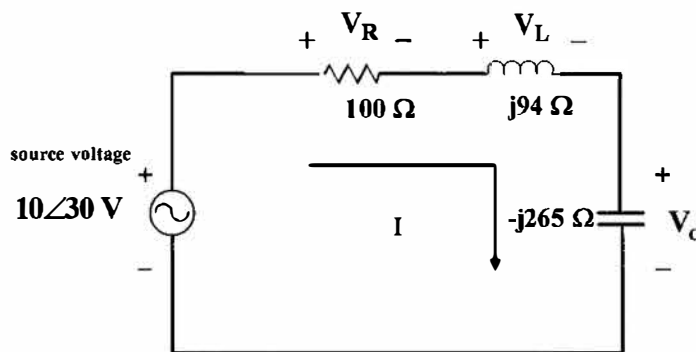

Figure 1.9: Circuit for illustrating phasor diagrams.

We saw earlier that the phasor current was $I = 0.51 \angle 90^\circ$ A. We use this value to calculate the three phasor voltages V_R , V_L , and V_C shown in Figure 1.9. Therefore,

$$V_R = (0.51 \angle 90^\circ)(100) = 51 \angle 90^\circ \text{ V}$$

$$V_L = (0.51 \angle 90^\circ)(j94) = 47.9 \angle 180^\circ \text{ V} \tag{Eq. 1.24}$$

$$V_C = (0.51 \angle 90^\circ)(-j265) = 135 \angle 0^\circ \text{ V}$$

Within calculator round-off accuracy we will find that $V = V_R + V_L + V_C = 100 \angle 30^\circ \text{ V}$ as it should, according to KVL.

A phasor diagram showing the above four voltages is given in Figure 1.10 You will be making a phasor diagram from your laboratory measurements.

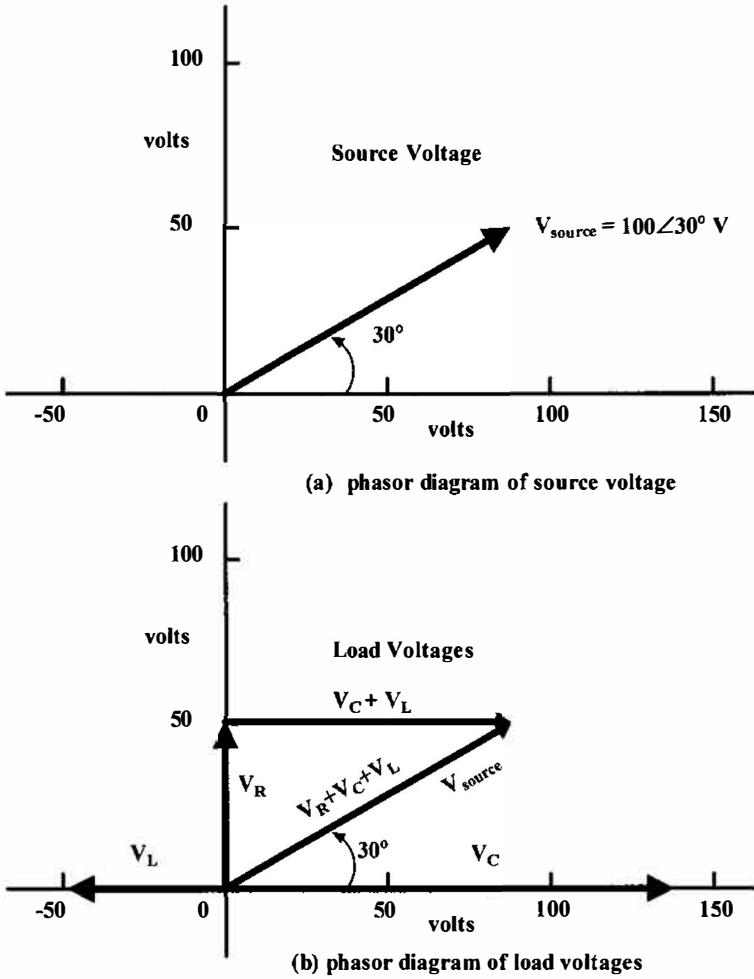

Figure 1.10: Phasor diagram of AC circuit from Figure 1.9.

Transformers:

Three major areas in which we use transformers are in (a) power distribution, (b) converting AC voltage to DC voltage, and (c) electronics.

Of these three, the power transformers used for stepping-up and stepping-down voltage is the most familiar and the most widely used application of this device. Power transformers are rather large. Most of us have seen the giant transformers in substation yards. These require using special cooling fans and a circulating fluid. At the next level we find transformers used in distributing power to industry and residential areas. We have all seen transformers mounted on power poles and in more modern subdivision, mounted in a metal housing at ground level. You will have the opportunity to study more about power transformers in your junior year. For this laboratory exercise we will focus on the transformers used in electronics.

In electronics, small transformers (compared to power transformers) are frequently used for converting AC to DC. In addition to AC to DC conversion, transformers are also used for isolating one circuit from another and for impedance matching.

In this laboratory exercise you will take a brief look at the application of stepping-up and stepping-down voltage (current) and impedance reflection from one side of the transformer to the other.

One can separate transformers into two categories: the *linear transformers* and the *ideal transformer*. The coils of a linear transformer are wound on a non-magnetic material such as plastic, wood, and air core. Refer to your text for a further explanation of how to analyze the linear transformer. A brief background of the ideal transformer is given in the following paragraphs.

Three main distinguishing features of the ideal transformer are:

- The coils are wound on a magnetic material such as laminated iron.
- The inductances L_1 , L_2 and M are very large, that is, they approach infinity. In this case L_1 is the inductance on the primary side of the transformers, L_2 the inductance on the secondary side and M the mutual inductance.
- The coefficient of coupling of the transformer is unity. This implies that the coils are tightly wound with respect to one another. In reality they are wound together, with the wires of the primary intermeshed with those of the secondary.
- The coils are lossless, that is, the resistances (R_1 and R_2) of both the primary and secondary are assumed to be zero.

The schematic (symbol) used for the ideal transformer is shown in Figure 1.11.

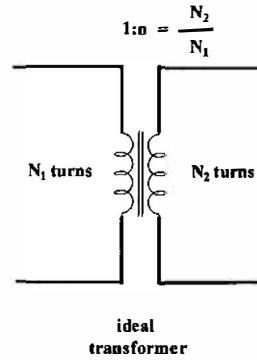

Figure 1.11: Schematic of the ideal transformer.

The primary voltage and current are related to the secondary voltage and current by the turns ratio and dot markings. These relationships are developed in the text for ECE 202. We assume a transformer with the dot markings, voltage polarity, and current direction as shown in Figure 1.12.

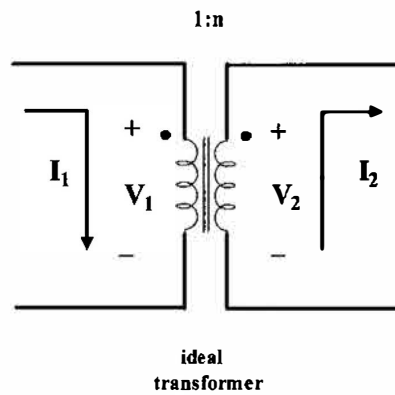

Figure 1.12: The ideal transformer with dot markings and voltage-current identified.

By assuming all the flux of the primary links all the turns of the secondary and by assuming that the resistances of the primary and secondary are zero, we can write (Faraday's Law);

$$v_1(t) = N_1 \frac{d\phi(t)}{dt} \qquad v_2(t) = N_2 \frac{d\phi(t)}{dt} \qquad \text{Eq. 1.25}$$

Taking the ratio of v_2 to v_1 and assuming phasor voltages gives

$$\boxed{\frac{V_2}{V_1} = \frac{N_2}{N_1} = n} \qquad \text{Eq. 1.26}$$

By assuming a lossless transformer we can say that the power supplied to the primary is equal to the power delivered to the secondary. Mathematically, this means that

$$V_1 I_1 = V_2 I_2 \quad \text{Eq. 1.27}$$

Combining Equations 1.26 and 1.27 gives,

$$\frac{V_2}{V_1} = \frac{I_1}{I_2} = \frac{N_2}{N_1} = n \quad \text{Eq. 1.28}$$

A prudent person will remember; as the voltage is stepped-up in a transformer, the current is stepped-down.

Two things worth mentioning here are;

- If one of the plus signs on the polarity markings of the transformer is reversed then in the ratio of V_2 to V_1 there will be a negative sign in front of n . Similarly for current; if the direction of either I_1 or I_2 is changed, there will be a negative sign in front of n .
- There is neither $I_x(j\omega L)$ terms nor a $I_x(j\omega M)$ term when writing KVL for the ideal transformer.

Now let us consider some practical aspects. For any given coil, we can write to a good approximation,

$$L = \frac{N^2 \mu A}{l} \quad \text{Eq. 1.29}$$

where

- A is the cross sectional area of the coil of wire forming the inductor
- μ is the permeability of the core of the coil
- N is the number of turns of wire that make up the inductor
- l is the length of the inductor

To make L large, in particular to make it approach infinity as stated in the assumption of the ideal transformer, requires lots of turns, large cross sectional area, short l , large permeability. Various combinations of these can be used to increase L . For example, the relative permeability of iron and steel are approximately 5000 times larger than air. Thus, the ideal transformer uses a ferromagnetic material such as laminated steel alloy to increase L . Invariably, for audio transformers, the number of turns, N , is made large to increase L . In making N large, one usually uses a large gauge wire # (the larger the gauge #, the smaller the wire diameter) to control the physical size and weight of the transformer. We recall that the resistance of wire is given by,

$$R = \frac{\rho l}{A} \quad \text{Eq. 1.30}$$

where

- A is the cross section area of the wire
- l is the length of the wire
- ρ is resistivity, usually copper

Using small gauge wire and lots of turns for making the coil invariably leads to resistance in the coil of the inductor. As a reference point, recall that the small transformer included in the parts kit, and used earlier, has a nominal primary inductance of 19.2 H, along with a resistance of 200 ohms. Each secondary has about 0.45 H with 15 ohms. In this case the primary has about 5.4 times the number of turns of the secondary. As another example, the small inductor used in this lab for the AC circuits work has 100 mH and a nominal resistance of 90 ohms.

Before considering a realistic model of the ideal transformer, first we consider the ideal case as shown in Figure 1.13.

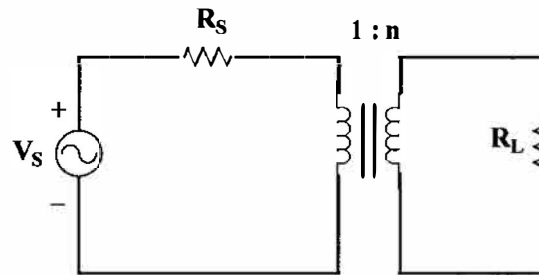

Figure 1.13: Ideal transformer configuration.

It is easy to show that the load impedance is reflected as shown in Figure 51.14 for this case.

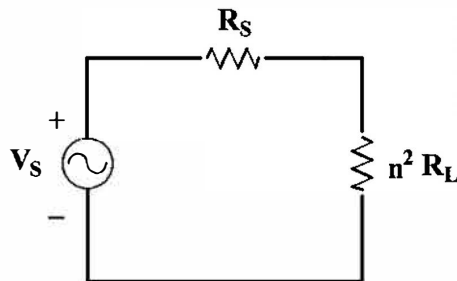

Figure 1.14: Reflected load resistance for a ideal transformer.

A more realistic model of an ideal transformer (accounting for the resistance of the windings) that has a source voltage along with a series resistor and a load resistance would be as shown below.

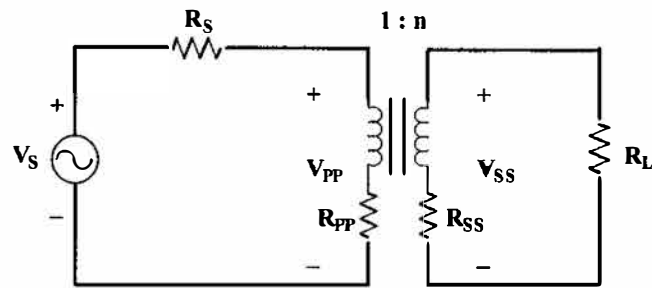

Figure 1.15: Ideal transformer including coil resistance.

A circuit showing how the resistance is reflected to the source side of the transformer is shown in Figure 1.16. We have found that this model gives reasonable results when using the transformer of the ECE 300 kit. You will be measuring the source side voltage, V_{ss} , in the laboratory.

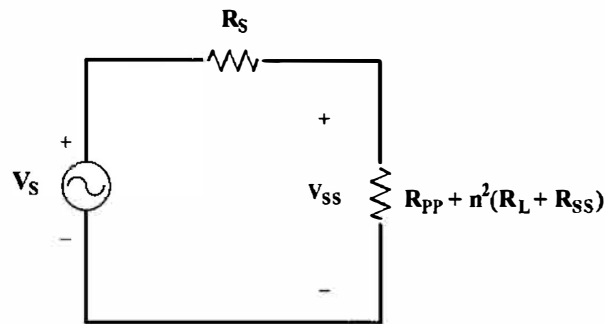

Figure 1.16: Diagram showing load resistance reflected to source
In modified ideal transformer circuit.

The reason the transformer is used in this manner is that often, particularly in electronics, a speaker(s) will be connected to a power amplifier. We would like to have maximum power transfer. We recall that the load resistance and the source resistance should be the same for achieving maximum power transfer. For example, if the power amplifier had 1000 ohms output resistance and one had a transformer with $n = 10$, then ideally a 10 ohm load resistor would be reflected as 1000 ohms and maximum power transfer would be achieved.

Prelab Exercises

Complete the following exercises prior to coming to the lab. As usual, turn-in your prelab work to the lab instructor before starting the Laboratory Exercises.

Part I PE:

Half wave rectifier. The purpose of this exercise is to illustrate the nature of the positive polarity and negative polarity of a sinusoidal signal.

Assume you are given a $4700\ \Omega$ resistor and a 1N4004 diode. You are to use these elements in a circuit connected to a sinusoidal signal source so that you produce the signals shown in Figure 1.17. Show your circuit diagram that produces these waveforms.

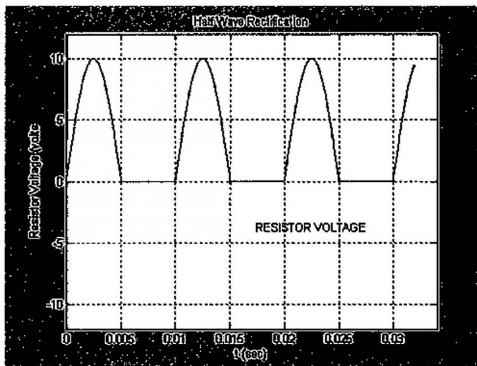

(a) voltage on positive swing of sine wave

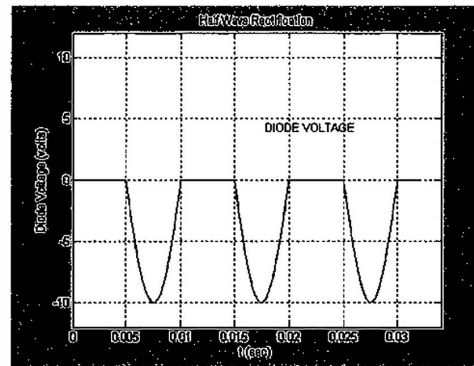

(b) voltage on negative swing of sine wave

Figure 1.17: Desired voltage waveforms, Part 1PE.

Part 2 PE: Circuit impedance. Consider the circuit of Figure 1.18.

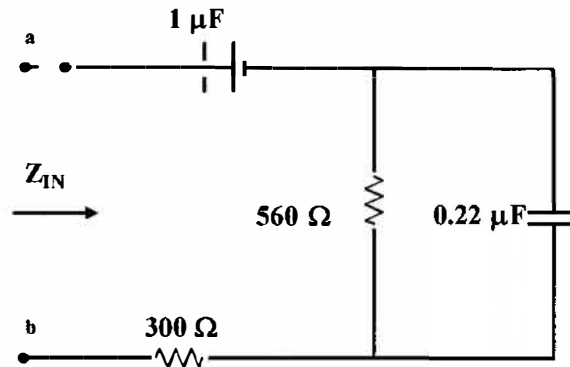

Figure 1.18: Circuit for determining impedance, Part 2PE.

If this circuit has a 1000 Hz source connected between terminals a-b, determine Z_{in} .

Part 3PE: Series RC circuit. Consider the circuit shown in Figure 1.19.

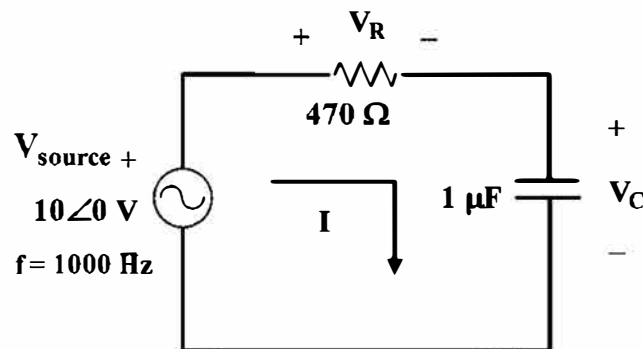

Figure 1.19: AC circuit for Part 3PE.

- (a) Calculate the phasor voltages V_R and V_C .
- (b) Draw the phasor diagram showing V_{source} , V_R and V_C .

Part 4PE: Series RLC circuit. Consider the circuit of Figure 1.20.

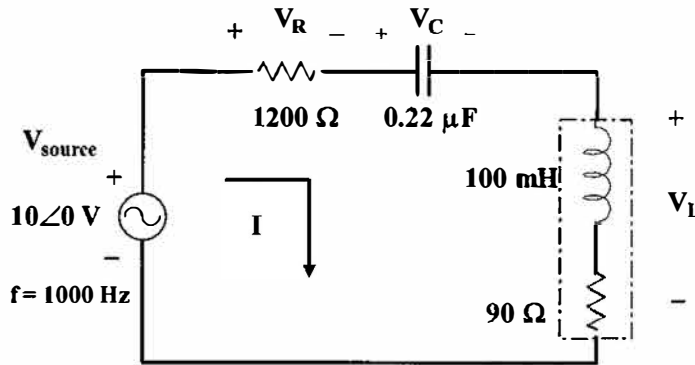

Figure 1.20: AC circuit for Part 4PE.

- (a) In the following calculations, ignore the 90Ω resistance that is inherent with the transformer coil. Calculate the phasor voltages V_R , V_L and V_C when the frequency of the input signal is 1000 Hz.
- (a) Draw the phasor diagram showing V_{source} , V_R , V_C and V_L .

Part 5PE:

- (a) Consider the circuit shown in Figure 1.21. Calculate the total resistance the source will see, to the right of P_1 - P_2 , after the 20Ω load resistance and the 15Ω resistance in the S_1 - S_2 coil are reflected to the source side of the transformer and the 200Ω present from the source side of the transformer is added to the reflected resistance.

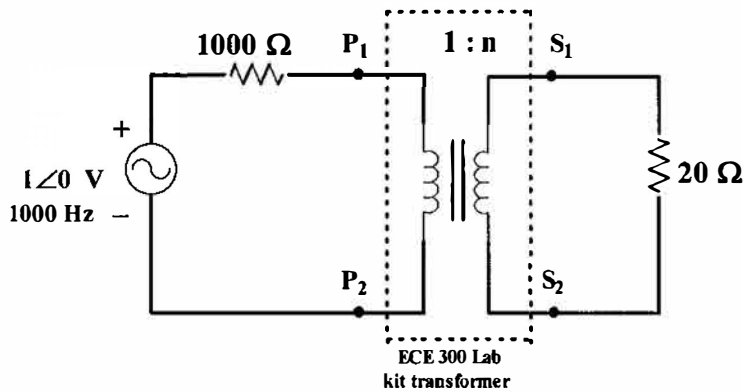

Figure 1.21: Circuit connection for Part 5PE.

- (b) With the input sinusoidal voltage set to 2 volts peak to peak at 1000 Hz, calculate the voltage across P_1 - P_2 and across the 1000Ω source side resistor.

Laboratory Exercises

Part 1LE: Half wave rectifier circuit.

Connect (build) the circuit you designed in Part 1PE. Measure and record the resistor voltage and the diode voltage. Obtain a print out of both the waveforms.

Part 2LE: Circuit impedance. Connect the circuit of Figure 1.22 with a source as shown below. Measure and record the value of V_{300} , both magnitude and phase. You should measure the phase shift of V_{300} by noting the time shift with respect to the source voltage. If needed, the lab instructor can give you help with this.

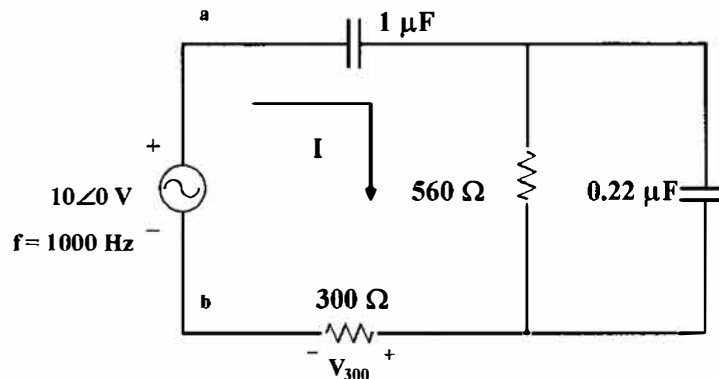

Figure 1.22: Circuit for Part 2LE.

Part 3LE: Series RC circuit.

- Connect (build) the circuit shown in Figure 1.23
- Measure and record the voltages V_{source} , V_R and V_C . Use the appropriate oscilloscope keys to measure the phase shift of V_R and V_C relative to V_{source} .

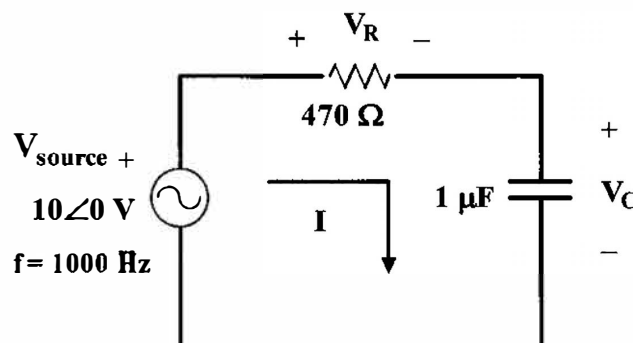

Figure 1.23: Circuit for Part 3LE.

Part 4LE: Series RLC circuit.

(a) Connect (build) the circuit shown in Figure 1.24

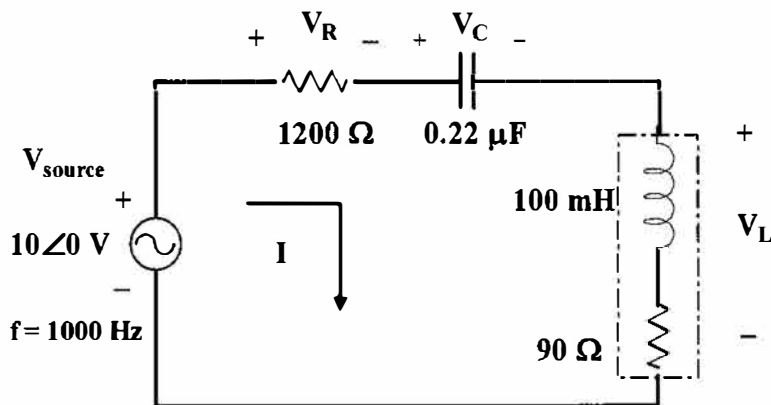

Figure 1.24: Circuit for Part 4LE.

(b) Apply an input signal of $10\angle 0$ at 1000 Hz. Measure and record the voltages V_{source} , V_R , V_C , and V_L . Use the appropriate oscilloscope keys to measure the phase shift of V_R , V_C and V_L relative to V_{source} .

Part 5LE:

(a) Set up the circuit of Figure 1.25 without the load resistance. Apply a 2V peak to peak sine wave of 1000 Hz.

(b)

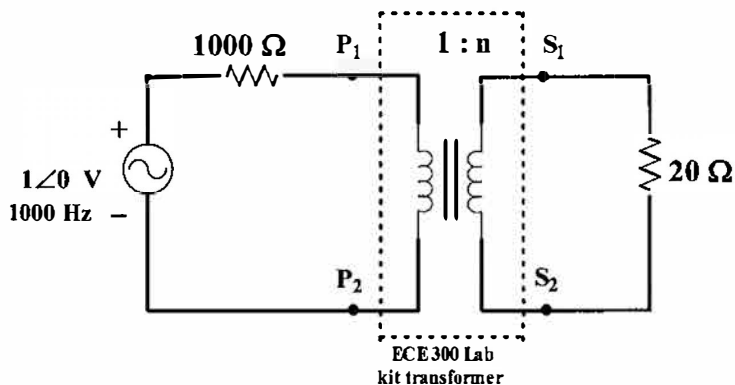

Figure 1.25: Circuit for Part 5LE.

(c) Measure the voltage across the transformer terminals, $S_1 - S_2$ and $P_1 - P_2$.

(d) Measure the voltage across the 1000 Ω resistor.

Before Leaving The Laboratory

Be sure the following is completed before you leave the laboratory.

- (a) Check to be sure that you have all the required measured values of Parts 1LE, 2LE, 3LE and 4LE.
- (b) Have the laboratory instructor check your laboratory measurements and recorded waveforms.
- (c) Restore your laboratory station (equipment and chairs) to the condition they were in when you arrived. Remove any debris from the work area and floor.

Thank you for your cooperation.

Questions, Comparisons and Discussions

The following should be completed and included with your laboratory report.

- (a) Show the rectifier circuit you designed for the rectifier circuit of Part 1 PE.
- (b) Compared the directly calculated impedance from Part 2PE with the impedance determined from V_{source}/I , where I is calculated using $I = V_{300}/300$.
- (c) Construct a small table showing the calculated and measured voltages for the RC and RLC circuits of Figures 5.23, and 5.24, respectively.
- (d) Use the measured values of voltages for Part 3LE to construct phasor diagram. Use the measured values of voltages for Part 4LE to construct a phasor diagram.

Laboratory Report

The following should be included in your laboratory report. If you have any questions be sure to contact the lab instructor.

- (a) Give a short summary (50 to 100 words) of what is to be accomplished in the lab exercise.
- (b) Write the procedure followed for each part of lab Work.
- (c) Tabulate all you readings.
- (d) Present all the printouts of the oscilloscope screen neatly labeled.
- (e) Answer the questions listed above.
- (f) Write a brief conclusion (approximately 200 words)
- (g) Attach the graded prelab at the end of your report.