

VX-510

*VHF Hand-Held Portable
Land Mobile Transceiver*

OPERATING MANUAL

American Communication Systems

Discover the Power of Communications™

TO ORDER – VISIT <http://www.ameradio.com>

VERTEX STANDARD CO., LTD.

4-8-8 Nakameguro, Meguro-Ku, Tokyo 153-8644, Japan

VERTEX STANDARD

US Headquarters

10900 Walker Street, Cypress, CA 90630, U.S.A.

YAESU UK LTD.

Unit 12, Sun Valley Business Park, Winnall Close
Winchester, Hampshire, SO23 0LB, U.K.

VERTEX STANDARD HK LTD.

Unit 5, 20/F., Seaview Centre, 139-141 Hoi Bun Road,
Kwun Tong, Kowloon, Hong Kong

VERTEX STANDARD (AUSTRALIA) PTY., LTD.

Normanby Business Park, Unit 14/45 Normanby Road
Notting Hill 3168, Victoria, Australia

Congratulations!

You now have at your fingertips a valuable communications tool - a yaesu two-way radio! Rugged, reliable and easy to use, your yaesu radio will keep you in constant touch with your colleagues for years to come, with negligible maintenance down time.

Please take a few minutes to read this manual carefully. The information presented here will allow you to derive maximum performance from your radio. After reading it, keep the manual handy for quick reference, in case questions arise later on.

We're glad you joined the yaesu team. Call on us any time, because our business is communications. Let us help you get your message across.

NOTICE

There are no user-serviceable points inside this transceiver. All service jobs must be referred to your Authorized Service Center or Network Administrator.

VX-510 Series

VHF Hand-Held Portable Land Mobile Transceiver

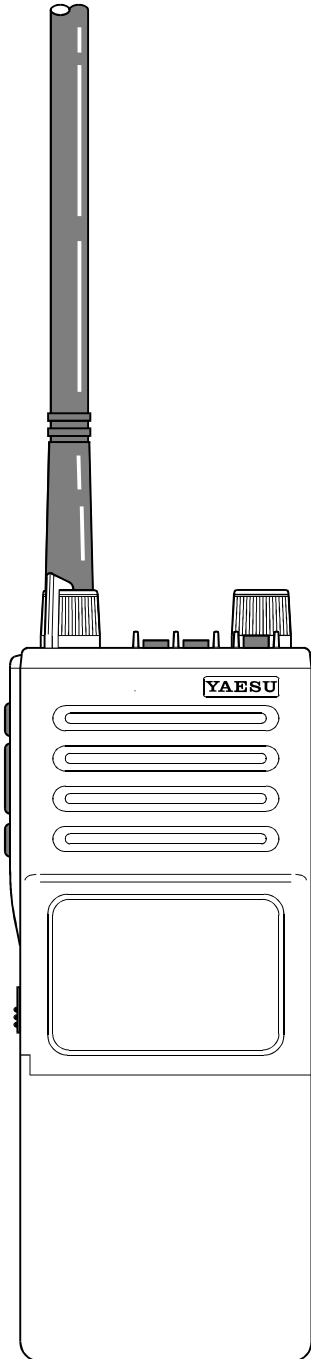

The VX-510 is a frequency-synthesized, microprocessor-controlled FM hand-held portable transceiver providing up to five watts of power output on up to 32 channels in the VHF Land Mobile Bands. Designed specifically for commercial and professional applications, the VX-510 is housed in high-strength die-cast aluminum alloy, sealed to MIL-810 C, D & E intrinsically safe (I/S) and weather-tight specifications.

User selectable features include a four-mode display with channel name or number, upright or inverted for easy viewing when on your belt; selective channel scanning, adjustable-pause priority scanning, and variable transmitter power output.

Other user-selectable features include push-button display illumination, voice encryption for privacy during communications (with optional FVP-22 Unit installed), and manual squelch override. The VX-510 is easily programmed by your dealer using a Yaesu Service Kit with an IBM PC-compatible computer.

Please read this manual carefully to become familiar with the features of the VX-510.

SPECIFICATIONS

General

Frequency range (MHz):	29.8 – 38 MHz (vers.A) or 38 – 50 MHz (vers.B)
Channels:	Up to 32 (simplex or semi-duplex)
Maximum Channel Spread:	8.3 MHz (vers. A) or 12 MHz (vers. B)
Minimum Channel Spacing:	20 kHz (12.5 kHz optional)
Programming Channel Step:	5/6.25 kHz
Emission Type:	16K0F3E (11K0F3E optional)
Supply Voltage:	7.2 V DC 10%
Current Consumption:	50 mA (stby, saver off) 19 mA (stby, saver on) 200 mA (receive) 2000 mA (transmit)
Case Size (W x H x D):	59 x 149 x 39mm
Weight (approx.):	570 grams

Receiver

Receiver Circuit Type:	Double-conversion Superheterodyne
Intermediate Frequencies:	21.6 MHz (ver. A), 16.9 MHz (vers.B) & 455 kHz
12-dB SINAD Sensitivity:	better than 0.20 μ V
20-dB Noise Quieting:	better than 0.30 μ V
Squelch Threshold:	better than 0.18 μ V
Adjacent Channel Selectivity:	75 dB
Image Rejection:	80 dB
Intermodulation Response:	70 dB
Hum & Noise:	50 dB
Audio Response:	+3/-8 dB from the 6 dB/oct. De-emphasis curve
AF output (for 5% THD):	0.5 watts @16 Ω

Transmitter

Power Output:	5W/1W
Frequency Stability:	\pm 10 ppm
Modulation System:	variable reactance
Maximum Deviation:	\pm 5 kHz (\pm 2.5 kHz optional)
Audio Response:	TIA/EIA-603 3.2.6
FM Hum and Noise:	better than -50 dB
Spurious Emissions:	60 dB below carrier
AF Distortion (@ 1 kHz):	< 5% @60 % modulation
Microphone Type:	2-k Ω condenser

Specifications may be subject to change without notice or obligation.

ACCESSORIES & OPTIONS

MH- 30_{A2B}	Speaker/Microphone
MH- 45_{A2B}	Speaker/Microphone
FNB-29A	7.2 V/1700 mAh Ni-Cd Battery Pack
VAC-520	Rapid Desktop Charger
ATL-1A	VHF Low Band Helical Flex Antenna (30 – 36 MHz)
ATL-1B	VHF Low Band Helical Flex Antenna (36 – 42 MHz)
ATL-1C	VHF Low Band Helical Flex Antenna (42 – 50 MHz)
FVP-22	Encryption Unit
FTT-7	DTMF Keypad Tone Generator (16 keys)
FTT-7D	DTMF Keypad Tone Generator w/Decoder
FTE-19	ANI (Auto Numbering Identification) Unit
CE-21	Programming Software
VPL-1	Programming Cable
VTP-20	VX-Trunk II VX-Trunking Portable Logic Board
CLIP-4A	Belt Clip

CONTROLS & CONNECTORS

Top panel

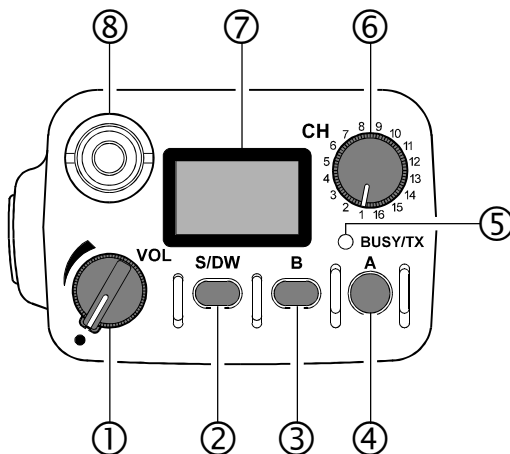

① VOL Control

This control adjusts the volume of the receiver, and turns the radio off when rotated fully counterclockwise to the click-stop

② S/DW Button (Scan/Dual Watch)

Momentarily (< 1sec.) pressing this button turns the channel scanner on and off. Pressing and holding (> 1 sec.) this button activates the Dual Watch feature (explained later).

③ B Button

Pressing and holding this button more than 2 seconds (but less than 4 seconds) activates functions as programmed by your dealer and determined by your system requirements (See “PRE-PROGRAMMED FUNCTIONS”, page 13). Pressing and holding this button more than 4 seconds inverts the LCD display to either frontward or backward facing readout (the backward display is convenient for viewing when wearing the transceiver on your belt).

CONTROLS & CONNECTORS

④ A Button

Pressing and holding this button more than 2 seconds (but less than 4 seconds) also activates an assigned function (programmed by your dealer). Pressing and holding this button more than 4 seconds causes the selected channel to be assigned as the Priority Channel for use with Priority Scanning and Dual Watch functions (explained later).

⑤ BUSY/TX Indicator

This lamp blinks green when a signal is being received (or the squelch is opened by pressing the **MON RES** button) and red when transmitting. To avoid interference, do not transmit if the lamp is glowing green. When the battery almost depleted, this lamp blinks red, indicating that the battery needs recharging or replacement very soon.

⑥ CH Rotary Selector

This rotary switch selects the operating channel. If a channel is selected that is not available for operation, "-- -- -- --" is displayed, accompanied by a rapid warning beeper (2 beeps/sec.).

⑦ Antenna Jack

This threaded-type jack accepts the supplied flexible antenna. Any other antenna types used here must be designed for the programmed operating frequencies.

⑧ Liquid Crystal Display

In addition the channel number name, the display includes some operating status symbols, indicated in the diagram below.

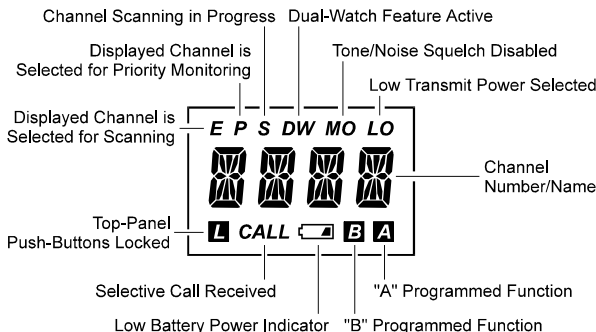

CONTROLS & CONNECTORS

Side Panel Buttons

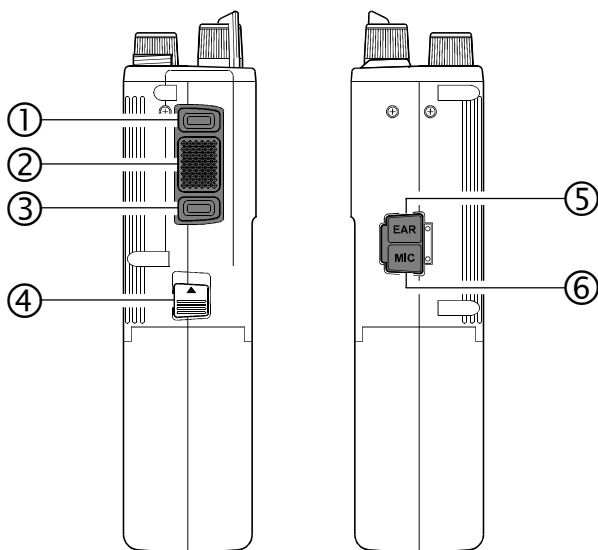

① **MON RES (Monitor/Reset) Button**

Pressing and holding this button more than 2 seconds (but less than 4 seconds) disables the tone squelch, and permits monitoring of stations transmitting on the selected channel while still keeping your receiver quiet from noise (“**MO**” will appear at the top right of the LCD). Press it again to only hear calls within your network.

Pressing and holding this button more than 4 seconds toggles the tone and noise squelch override, allowing all stations (and noise) on the channel to be heard. This may be used to hear weak stations whose signals would not normally open the squelch. Do this to pre-adjust the VOLUME control before receiving calls.

(With Selective Calling Option)

When the two-tone sequential decoder unit (F2D-5) is installed, and a selective call has been received (“**CALL**” indicator on), pressing and holding this button more than 2 seconds (but less than 4 seconds) will reset the call function on the current channel and silence the receiver, otherwise pressing and holding this button more than 4 seconds resets the call function on ALL channels.

CONTROLS & CONNECTORS

② PTT (Push-To-Talk) button

Hold this button to transmit (the “**BUSY/TX**” indicator glows red).

③ LAMP/LOCK button

Press this button momentarily (<1 sec.) to illuminate the display for five seconds. Pressing and holding (>1 sec.) this button locks top-panel push-buttons (**S/DW**, **B**, **A**, and the optional DTMF keypad); this can be enabled to prevent radio settings from being disturbed.

④ Battery Release button

Slide this button in the direction of the arrow (upward) for battery removal.

⑤ EAR Jack

This provides audio output for an earphone or the optional MH-30A2B External Speaker/Microphone here. The internal speaker is disabled when a plug is inserted into this jack.

⑥ MIC Jack

Connect the optional MH-30A2B Speaker/Microphone here, the internal microphone is disabled when this jack is used.

OPERATION

Preliminaries

If the transceiver has not been used since leaving the factory, fully charge the battery using CD-1 unit (with PA-14B or C) before using it.

Mount the battery on the transceiver as described and shown in the photo below. Also, install the antenna on the jack on top of the transceiver by screwing the connector into the jack until it is finger-tight.

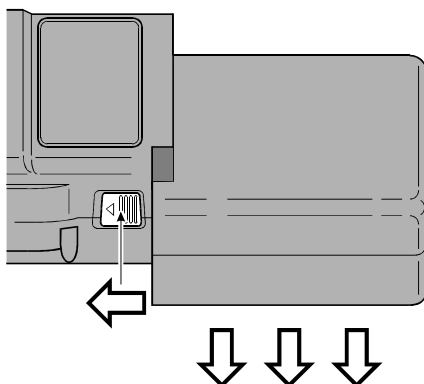

Battery Removal & Replacement

- Make sure that the **VOL** control is set into the off click-stop, and remove the protective soft or hard case, if used.
- Grasp the transceiver with your left hand, so your palm is over the speaker and your thumb is on the Battery Release Button.
- Move the button in the direction indicated by the arrowhead, while using your right hand to slide the battery pack toward the side with the button. The battery pack should slide smoothly out of its track.
- To replace the Ni-Cd pack, repeat the second and third steps above, simply sliding the battery case in the other direction after aligning the shorter side of the battery pack with the track below the Battery Release Button.

OPERATION

Preliminary Steps

Before operating the transceiver for the first time:

- Charge the battery pack and connect the supplied helical rubber flex antenna to the antenna jack on the top of the transceiver. *Never operate the transceiver without an antenna connected.*
- If you have a Speaker/Mic, we suggest you do not connect it until you are familiar with basic operation.
- Before proceeding, please review the “*Top & Side Panel Controls*” outline, if you have not already, to familiarize yourself with the functions of the controls.

Basic Operation

- Switch on the transceiver by rotating the **VOL** control clockwise out of the click-stop (a momentary beep will sound). For now, adjust the control to about mid-position (12-o’clock), later you can adjust the level to suit the operating environment.
- Rotate the **CH** knob to select a channel for operation, the LCD will show the currently selected channel. If “-- -- -- --” is displayed, along with a rapid (2 beeps/sec.) beeping tone, the selected channel position is not available for operation.
- To transmit, wait until the channel is clear (“**BUSY/TX**” LED off), then press in the **PTT** switch on the side of the transceiver while speaking across the face of the radio. A clear normal voice will provide the best quality transmission. For maximum battery life, select low power output (covered later) whenever possible. During transmission the “**BUSY/TX**” indicator glows red. Release the **PTT** switch to receive.
- To receive weak stations better, try positioning the radio as high and far away from your body as possible, or disable the squelch momentarily by holding the **MON RES** button on the side of the radio for > 4 sec. (until the second low/high beep sounds). With the squelch disabled, the “**BUSY/TX**” indicator will blink green and channel noise and weak stations can be heard. To quiet the radio again, press the **MON RES** button again momentarily.
- When you are done operating, be certain to turn the **VOL** control to the off position to conserve battery life.

OPERATION

An important note about your radio !

Some of the radio/button functions discussed next will only operate in your radio if so programmed by your dealer, or after the installation of certain internal optional units. In this way, the radio's operation can be simplified and customized specifically for the user according to network requirements. If pressing a button on your radio does not result in the same function described in this manual, or if you are uncertain of the functions your particular radio is configured with, contact your dealer. See "**PRE-PROGRAMMED FUNCTIONS**" on page 13.

Scanning

Scanning allows you to sequentially check for calls on all or only those channels you select. To start scanning, press the **S/DW** button momentarily. A beep then sounds and the display will clear and show "SCAN". Scanning will pause when a signal is received, at which time the channel number(or alphanumeric tag) will be displayed. A small "**S**" will be displayed above the channel, indicating the scanner is still active, but paused.

During this pause, you can press the **PTT** switch and talk to the station. Otherwise, scanning will resume a few seconds after the signal is no longer present. While scanning, if you momentarily press the **PTT** switch, operation automatically shifts to a default channel. This default channel can be set to the priority channel (both "**P**" and "**S/DW**" are displayed), last-busy channel, or home channel, *depending on how your radio was programmed.*

To stop scanning, simply press **S/DW** momentarily again. Operation will return to the channel that was last selected when scanning was activated.

If enabled by dealer programming, you may select only the channels you want to scan, and have others skipped-over by performing the following routine.

Turn the radio OFF, then depress the **S/DW** button while turning the radio back ON again. "PROG" will momentarily appear on the display, after which it will revert to the currently selected channel (this indicates you are in the programming mode). If user-access is disabled "INH" will appear briefly.

OPERATION

Use the **CH** knob to select a channel, then press the **S/DW** button to enable the channel for scanning (“**E**” will appear in the upper left corner of the LCD). Repeat this process for each channel you want the scanner to check.

To remove a channel from those to be scanned, press **S/DW** again, so that “**E**” no longer appears in the display.

After you have enabled all the channels you want to scan, turn the radio off, then on again to return to normal operation.

Priority Scanning

Priority scanning allows you to scan and monitor channels while the receiver periodically checks for calls on a pre-selected (“priority”) channel. You may want to use this feature if you want to scan different channels, but don’t want to miss a call for you on a primary dispatch, emergency or tactical frequency. After a call has been received on the priority channel, operation returns to the programmed default channel scheme, as mentioned before. Only *one channel at a time* can be selected as the priority channel.

- To set the currently displayed channel as the priority channel, just press and hold the **A** button for 4 sec. A small “**P**” will now appear at the top left corner of the display whenever this channel is selected, along with an accompanying “beep”.

When a priority channel has been selected, the scanner will check the priority channel regularly as you scan the other channels. If a signal appears on the priority channel, the scanner will pause and operation will jump to the priority channel. Otherwise, the scanner will pause on active non-priority signals as previously described.

If a call comes in on a non-priority channel that you need to respond to, just press the **PTT** switch while the scanner is paused on that channel. As long as no call comes in on the priority channel, you can send and receive on the other channel: scanning will resume when you finish and the channel clears.

OPERATION

Dual Watch

If you need to operate on a non-priority channel while still checking for calls on the priority channel, the Dual Watch feature let's you to do this without using the scanner. When enabled, operation on any selected non-priority remains normal as before, however, when a signal is received on the priority channel or when you press the **PTT** switch, operation immediately shifts to the priority channel. The rate at which the Dual Watch feature samples the priority channel can be set by the user.

- To begin Dual Watch operation, first assign a priority channel as described before, then select the non-priority channel you wish to operate on.
- Press and hold the **S/DW** button until the second beep sounds, “**DW**” (but not “**S**”) will appear at the top of the display.
- To manually shift to the priority channel, press the **PTT** switch. At this time you make transmit, otherwise, if no signal is received within 2 seconds, operation will revert back to the other selected Dual Watch channel.
- To turn off the Dual Watch Feature, press and hold the **S/DW** button again (“**DW**” will disappear in the display).

Low Battery Power Indication

When the rechargeable Ni-Cd battery pack voltage reaches a low level, the “” indicator appears at the lower right corner of the LCD, and the “**BUSY/TX**” indicator will blinks red. *Immediately remove the Ni-Cd pack and install a freshly charged battery pack, or insert the radio into the charging stand for a complete recharge cycle.* If you plan to operate your radio for extended periods of time, you may want to keep a spare, fully-charged pack handy.

PRE-PROGRAMMED FUNCTIONS

The function selected by pressing and holding the **A** or **B** button more than 2 seconds (but less than 4 seconds) can be customized by dealer programming and your network requirements. A brief explanation of available functions is provided below. However, contact your dealer for details on their use and operation.

Low Transmit Power

This reduces the power output of your radio to approximately one watt to conserve battery life, and when full power is not needed to maintain reliable communications. “**LO**” will be displayed at the upper right corner when enabled.

Alpha Tag

This displays an alpha-numeric channel name, usually describing the channel, rather than merely displaying a channel number. These may be programmed to assist you in recognizing channels by name, rather than by memorizing channel numbers and their assignments.

Talk Around

This feature enables simplex operation on semi-duplex channels: the transmit frequency becomes the same as the receive frequency (regardless of any programmed offset for the channel).

Note: This feature has no effect on simplex channels.

Channel Group Selection

The 32 available channels in the VX-510 can be organized into 2 groups with up to 16 channels in each. Pressing and holding this button more than 2 seconds (but less than 4 seconds) lets you select a group for operation. Channels within each group are selected using the rotary dial.

Optional Accessory

Voice Encryption (FVP-22):

When installed, pressing and holding this button more than 2 seconds (but less than 4 seconds) will turn on the optional voice encryption unit for privacy during communications.

ENI (Emergency Numbering Identification) Unit (FTE-19):

When installed, pressing and holding this button more than 2 seconds (but less than 4 seconds) will turn on the optional ENI Unit, then *within 1/2 second*, press this button again to transmit the ENI signal.

BUTTON FUNCTIONS

As mentioned before, button functions can be customized by programming from your Yaesu dealer to meet your communications/network requirements. Some features may require the purchase and installation of optional internal accessories for operation. The table below illustrates the possible Top-panel button programming combinations. Functions are explained on the previous page “**PRE-PROGRAMMED FUNCTIONS.**” For further details contact your nearest Yaesu dealer. For future reference, check the box next to the function that has been assigned to the button on your particular radio, and keep it handy.

	Press and Hold (< 2 seconds)	Press and Hold (> 4 seconds)
A Button	<input type="checkbox"/> Channel Group <input type="checkbox"/> HI/LOW TX Power <input type="checkbox"/> Alpha Tag <input type="checkbox"/> Talk Around <input type="checkbox"/> Accessory (Voice Encryption) <input type="checkbox"/> Accessory (ENI)	Tags currently selected channel as the Priority Channel
B Button	<input type="checkbox"/> Channel Group <input type="checkbox"/> HI/LOW TX Power <input type="checkbox"/> Alpha Tag <input type="checkbox"/> Talk Around <input type="checkbox"/> Accessory (Voice Encryption) <input type="checkbox"/> Accessory (ENI)	Toggles the Top Panel LCD display between normal and inverted readout

	Press momentarily (< 1 second)	Press and Hold (> 1 second)	Press and Hold while Power-on
S/DW Button	Starts/Stops Channel Scanning	Starts/Stops Dual-Watch Feature	User-selectable channel scanning programming (if enabled)

CUSTOM SETTINGS

Below is a table of radio features that can be customized by dealer programming. To change a feature as your requirements change, contact your Yaesu dealer. For future reference, check the box next to the option that has been programmed in your particular radio, and keep it handy.

Feature	Options	Explanation
Channel Scan	<input type="checkbox"/> Enabled <input type="checkbox"/> Disabled	Channel scanning can be disabled completely for systems not requiring this feature.
Scan-Stop Resume	<input type="checkbox"/> 5-seconds <input type="checkbox"/> Carrier	In the 5-seconds mode, scanning pauses on a busy channel for 5 seconds, then resumes. In the Carrier mode, scanning pauses and remains on a busy channel until the station stops transmitting.
User-Scan Program	<input type="checkbox"/> Enabled <input type="checkbox"/> Disabled	If enabled, the user can program which channels are to be scanned; otherwise, dealer-programmable only.
Dual Watch	<input type="checkbox"/> Enabled <input type="checkbox"/> Disabled	Dual-Watch can be disabled completely for systems not requiring this feature.
Channel after PTT	<input type="checkbox"/> Priority Ch. <input type="checkbox"/> Home Ch. <input type="checkbox"/> Last-Busy	If the PTT is pressed during scanning, determines which default channel the radio returns to : the selected Priority Channel, a designated "Home" Channel, or the channel that was last-busy.
Monitor	<input type="checkbox"/> Enabled <input type="checkbox"/> Disabled	Enable/Disable the side-panel MON button (See pages 6 & 9).
A/B Button	See Table	Flexible dealer-programming as outlined in the table on the previous page.

RECEIVER SQUELCH SETTING

The squelch setting on your VX-510 is preset at the factory, and does not normally require re-adjustment. However, in the event that this should become necessary:

To adjust the squelch, use the Allen wrench to *loosen* the setscrew securing the **VOL** knob, then pull off the **VOL** knob. Rotate the small brass collar just above the base of the **VOL** control shaft, using a pair of tweezers, as shown below. Be careful not to loosen the larger mounting nut at the base of the control. When done, rotate the **VOL** control shaft fully to the counter-clockwise position (into the click-stop), and press the **VOL** control back on the shaft to align the indicator of the **VOL** control to the dot “●” on the top panel, then tighten the setscrew.

Adjustment of this control affects whether your radio can hear distant and nearby stations, or only nearby ones; therefore we recommend leaving the control as set, or having your Yaesu dealer perform the adjustment.

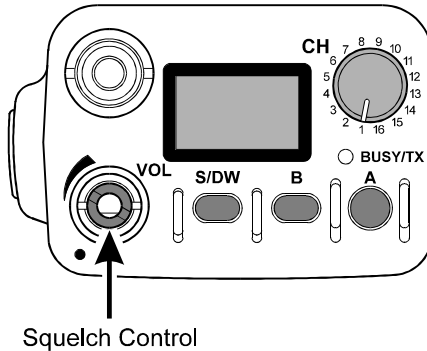

INSTALLING CHANNEL-STOPS

To simplify operation and prevent selection of unprogrammed/unused channels or channel groups, tiny metal inserts or “stops” can be inserted into the top panel beneath the **CH** selector knob. A tiny tab protruding from beneath the skirt of the **CH** knob engages the stop(s) as it is turned, preventing further rotation.

To insert a stop, rotate the **CH** knob to the channel “1” position and use the Allen wrench to *loosen* the setscrew locate the **CH** knob, then pull off the **CH** knob. Insert the stops firmly into the appropriate slot(s) for the desired channels, using a pair of tweezers or fine needle-nose pliers, according to the drawing below. For example, to limit **CH** selection to channels 1 - 4, insert one metal stop at the 9 o’clock position (slot), and the other at the 6 o’clock position. When done, press the **CH** selector knob back on the shaft, align the indicator of the **CH** knob to channel “1,” then tighten the setscrew.

Note: The use of mechanical stops should not be used or relied upon as the sole means to prevent selection or transmission on an invalid or unauthorized channel. Channels should be locked-out or TX-inhibited via programming by your Yaesu dealer, and stops inserted as a operating convenience to you and your network users.

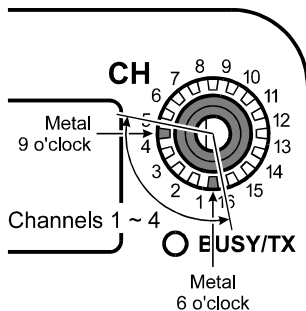

UNDERSTANDING RADIO WAVES

Radio waves travel from one point to another by several different means. The general term for these methods of wave travel is “propagation”. You may know that “shortwave” signals can be propagated over distances of several thousand miles by reflection off of the upper regions of the atmosphere.

Your hand-held transceiver, on the other hand, operates on the so-called VHF (Very-High Frequency) and UHF (Ultra-High Frequency) bands. On these bands, radio waves usually do not reflect off of the atmosphere. Instead, the radio waves behave almost as light: they travel in a straight line, and when they meet a building or obstruction, they go no further in that direction.

Therefore, it is important that you be as high and free from obstructions as possible to cover the greatest distance when using your radio. If you operate from inside a car or building, any metal around you can absorb much of the signal, both transmitted and received. Coverage may therefore be very poor under those conditions. However, if you must operate from indoors, moving next to a window will improve communications.

In view of the factors just discussed, you can easily see the potential benefit of holding the radio up high near your mouth while transmitting. In this way the antenna is high and clear, and coverage is best.

On final note regarding propagation is useful in improving coverage. Because radio waves at VHF and UHF are similar to light waves, they do reflect, to varying degrees, off of hills, buildings, and the like. In a crowded urban area, with many close buildings close together, many reflections may occur, and interfere with one another, causing variations in signal strength at different locations.

Therefore, if a signal is weak and you walk a few feet in any direction, reception may suddenly become clear, because a particular reflection path may become dominant. Reflections are frequently useful, as they can allow for communications between two stations over a highly obstructed path.

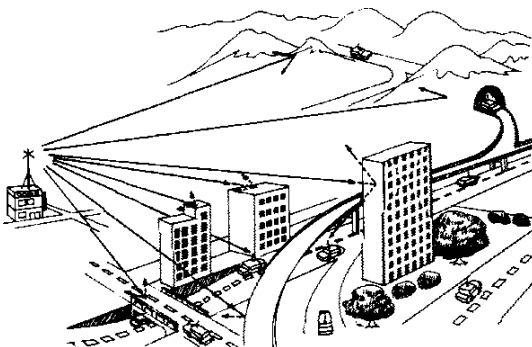

NOTE

NOTE

This device complies with Part 15 of the FCC rules.
Operation is subject to the condition that this device
does not cause harmful interference.



Copyright 2010
VERTEX STANDARD Co., Ltd.
All rights reserved.

Printed in Japan

No portion of this manual
may be reproduced
without the permission of
VERTEX STANDARD Co., Ltd.

