

LAYHER ALLROUND SCAFFOLDING®

INSTRUCTIONS FOR ASSEMBLY AND USE

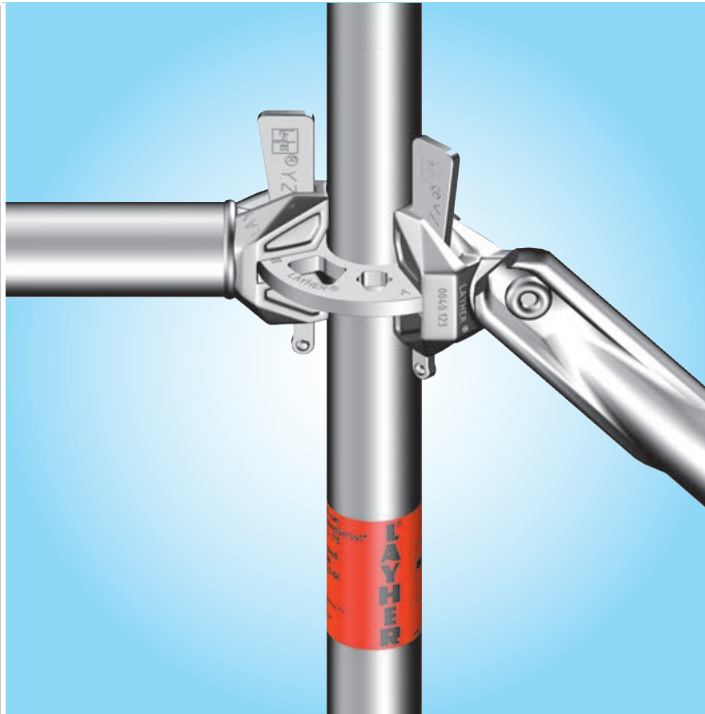

Edition 05.2013

Ref. No. 8116.230

Quality management
certified according to
DIN EN ISO 9001:2008
by TÜV-CERT



CONTENTS

1.	Introduction	4	17.	Bridging with lattice beams	38
2.	Measures to prevent falls	7	18.	Mesh guard	39
3.	General	10	19.	Ground adjustment.....	40
4.	Basic components of the Layher Allround Scaffolding.....	13	20.	Changes in standard configuration	41
5.	Façade scaffolding.....	17	21.	Use of the scaffolding	41
6.	Tower scaffolding	19	22.	Dismantling the scaffolding	42
7.	Birdcage scaffolding.....	21	23.	Basic components	43
8.	Support scaffolding	21			
9.	Circular scaffolding.....	22			
10.	Suspended scaffolding.....	24			
11.	Mobile scaffolding units.....	26			
12.	Anchoring.....	27			
13.	Accesses	30			
14.	Deck cutouts and deck inserts.....	34			
15.	Corner solutions.....	35			
16.	Brackets and cantilevers	36			

LOCAL REGULATIONS

The products or assembly variants shown in these instructions for assembly and use may be subject to local regulations.

The product user bears the responsibility for compliance with such regulations.

Subject to local regulations, we reserve the right not to supply all products illustrated here.

Your local Layher partner will be happy to provide advice and answers to all questions relating to the product approval, to their use or to specific assembly regulations.

1. INTRODUCTION

General

These instructions for assembly and use relate to assembly, modification and dismantling of a few representative applications of the Allround Scaffolding from Wilhelm Layher GmbH & Co. KG, of Gueglingen-Eibensbach, Germany. The instructions give general information and cannot cover all the possible applications. If a construction deviates from these instructions for assembly and use or other national health and safety requirements the scaffolding constructor has to develop suitable instructions relating to the stability of the scaffolding and to health and safety as part of the scaffolding erector's risk management process. The scaffolding contractor must ensure that all reasonably foreseeable hazards to health and safety associated with the erection, use or dismantling are identified before and during installation/dismantling of the scaffolding. Any hazard identified must be assured in terms of risk and must be controlled by the scaffolding contractor. These instructions do not dispense with the scaffolding contractor's obligation to perform his or her own risk assessment for any particular site or work method. If you have any questions about specific applications, please contact your Layher partner.



Fig. 1: Layher Allround steel acc. to Z-8.22-64



Fig. 2

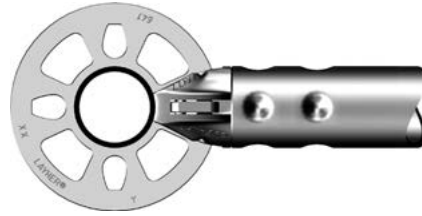

Fig. 3: Layher Allround aluminium acc. to Z-8.22-64.1

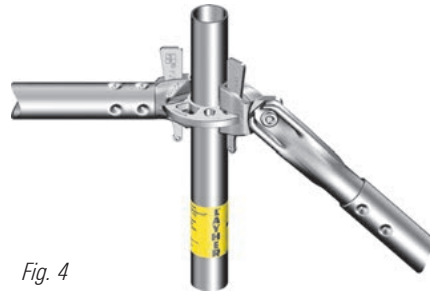

Fig. 4

Caution: The stability of the scaffolding must be verified and assured at all times, including the assembly, modification and dismantling state. Layher Allround Scaffolding may only be assembled, modified and dismantled under the supervision of a qualified expert and by technically trained employees.

During assembly, only original Layher Scaffolding components identified with the conformity mark <Ü> and the appropriate German approval number (Z-8.22-64 for steel and Z-8.22-64.1 for aluminium) may be used.

Visually check all scaffolding components prior to installation and before they are used to ensure that they are in flawless condition. Do not use damaged components.

Caution: Assembly, alteration and dismantling of the Layher Allround Scaffolding involves a risk of falls. Perform scaffolding assembly work in such a way that the risk of falls is avoided as far as possible and that the residual risk is minimized. Assembly situations where there is a risk of falls are indicated in these instructions with the following symbol inside the assembly pictures.



Fig. 5

The scaffolding erector must stipulate, on the basis of how he assesses the risk, suitable measures to prevent or minimize risks for the actual case and/or the respective activities involved.

The measures must be selected with due consideration of the actual risk, their usefulness and their practical possibilities, and also depending on

- the qualification of the employees,
- the type and duration of the activity in the high-risk area,
- the possible fall height,
- the state of the surface onto which the employee might fall,
- the state of the workplace and its access and
- the local regulations.

Technical and personnel-related measures can be applied during assembly, modification and dismantling. Possible measures can include, depending on the assembly situation, the use of qualified personnel specifically informed of the respective risk situation, the use of the advance guardrail, or the use of suitable personal safety apparatus. In any event, the assembly sequence must be designed such that side protection is installed at once, so that personnel work predominantly in secured areas.

If the use of fall-arrest systems or of an advance guardrail is required or is specified by local regulations when Layher Allround Scaffolding is being assembled, the attachment points shown in section 2 or the advance guardrail as shown must be used. The suitability of fall-arrest systems for fall prevention must be checked, with particular attention being given here to the assembly of the second and third scaffolding levels.

Before the start of scaffolding work, the contractor must ascertain whether the planned working area contains equipment that might endanger the employees. Assembly, modification and dismantling may only be performed with appropriate protective equipment. Scaffolding components must not be thrown; instead they must be handed over in such a way that they cannot slip or fall down.

After completion of the assembly work and before every use of the scaffolding, a check must be conducted to ensure it is in good condition. With regard to the following instructions for assembly and use of the Allround Scaffolding system, it must be pointed out that as a general principle scaffolding may only be assembled, modified or dismantled under the supervision of a qualified person and by technically trained employees adequately and specifically instructed in this work. To that extent, and with regard to use, we refer to the required conditions set forth in your local Occupational Health and Safety Regulations (OH&S). In the following instructions for assembly and use, we provide the erector and the user, on the basis of our risk analysis, with advice on how to comply with the requirements of OH&S in the respective assembly situation.

The technical details set forth in the instructions for assembly and use are intended to help the erector and/or user to comply with the requirements of OH&S and are not mandatory specifications for them. The erector/user must take the measures needed on the basis of a risk assessment to be prepared according to the preconditions of OH&S at their own discretion, exercising all due care and diligence. The specific features of the individual case must be taken into account here.

It is essential that the following instructions for assembly and use are complied with in every case. It is pointed out that all information, particularly that regarding stability in the assembly variants, applies only when original Layher components identified with the approval numbers stated on page 4 are used. The installation of non-Layher parts can lead to safety defects and insufficient stability.

The present instructions for assembly and use must be available to the supervisor and to the employees involved.

During assembly, modification and dismantling, as well as during use of the scaffolding, the national regulations for scaffolding design and health and safety concerning the erection and use of scaffolding must be complied with.

Inspection and Documentation

The scaffolding supervisor and inspector must ensure that the scaffold has been checked prior to use by a qualified person. The documentation should be visible from all access points of the scaffold. Any area of the structure that is incomplete or has specific use restrictions must be blocked off and clearly identified.

After completion of the scaffolding, it is useful to indicate that inspection has been passed by a clearly discernible identification on the scaffolding itself for the duration of its use. This identification should include the following information:

Identification examples:

- Compliance with national regulations for scaffolding design
- Name of scaffolding company
- Name of scaffolding supervisor/inspector
- Contact phone number
- Scaffold description
- Permissible load
- Date of erection
- Date of subsequent inspections

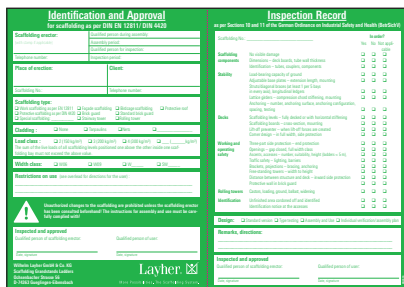

The form is titled 'Identification and Approval for scaffolding as per DIN EN 12811/DIN 4526' and 'Inspection Record as per Section 14.1 of the German Ordinance on Technical Safety and Health (Bstt ArbZ)'. It contains fields for 'Scaffolding description', 'Date of erection', 'Scaffolding type', 'Load class', 'Work class', 'Inspection date', 'Inspected by', 'Approved by', and 'Date of approval'. It also features a 'Permissible load' section with a table of load classes and a 'Remarks' section.

Fig. 6

Use

Every employer who requires personnel to use the scaffolding or parts of it must comply with local OH&S Regulations. The inspection is intended for confirmation of safe operation depending on the respective use of the scaffolding. After any unusual events that might have damaging effects on the safety of the scaffolding, person responsible must immediately ensure that an unscheduled inspection is performed by a qualified person and ensure that the scaffolding is checked for obvious defects before use. If defects are found during this check, the scaffolding must not be used in those areas where there are defects until these have been eliminated by the scaffolding erector. Subsequent alterations to the scaffolding are deemed as assembly, modification or dismantling and may only be performed by technically trained employees. If the scaffolding is used by several employers, simultaneously or successively, each employer must ensure that the above inspection is conducted.

The basis for the Allround Scaffolding approval in Germany are German and European standards. Allround Scaffolding has been approved in many other countries and complies with British standards.

Caution: Differing and supplementary local regulations are not taken into account in these instructions, but must be complied with.

A detailed list of articles can be found in our catalogue, and information on structural values in our technical documents.

Layher Allround Scaffolding may be used as work scaffolding and protective scaffolding according to the stated load classes, and in compliance with the present instructions for assembly and use and with the stipulations of local OH&S Regulations.



Fig. 7

2. MEASURES TO PREVENT FALLS

Preventing falls during assembly, modification or dismantling of the scaffolding

General

In line with your local relevant health and safety act and regulations or as the result of a risk analysis performed by the scaffolding erector, a fall-arrest system, an advance guardrail or other suitable higher order control (e.g. sequential erection or fully decking each lift) may be necessary for assembly, modification or dismantling of the scaffolding. The risk assessment should be carried out to ensure any controls implemented are both reasonably practicable and appropriate for the work that will be undertaken on the site.

Attachment points for fall-arrest systems

If the use of a fall-arrest system is planned for assembly, modification or dismantling of Allround Scaffolding, the attachment points shown in Figs. 8 to 12 can be used. The attachment points shown have been verified by tests using original Layher Allround Scaffolding. For components not marked in accordance with requirements of the building authority approval the stated anchor points do not apply.

WARNING

When assembling, modifying or dismantling scaffold, the scaffolder must be connected to an attachment point that is not part of (i.e. independent of) the scaffold bay being assembled or dismantled.

Attachment points for the fall-arrest system must be chosen as high as possible and must not be lower than the standing surface.

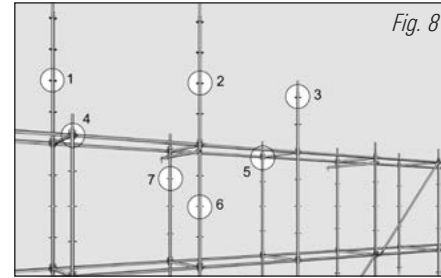

1, 2, 3	To a standard going all the way through at the height of the scaffolding level and without joint, maximum 1 m above the scaffolding level
4, 5	To a rosette at the level of the ledgers. The ledgers must be already fitted.
6, 7	To any rosette inside an assembled and finished scaffolding level
8, 9, 10	To an O-ledger max. 2 m above the assembled and finished scaffolding level. Standards projecting 2 m above the scaffolding level are shown; the connection of the ledger to vertical standards protruding 1 m is also permissible.
11, 12	To a ledger inside an assembled and finished scaffolding level



Fig. 10: Attachment in small or large hole of the rosette is possible. **(only valid for Allround Scaffolding steel – not for aluminium)**

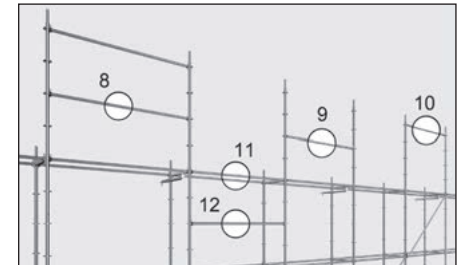

Fig. 11: Attachment points on the Allround ledgers; bay length maximum 3.07 m

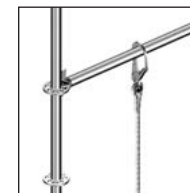

Fig. 12: Attachment to an O-ledger

If a fall-arrest system is to be used, it is essential that there be adequate clearance under the system so that in the event of a fall the user of the system will not strike the ground or any other obstacle beneath the system. When clearance from all obstructions is not possible, the selection and use of a fall-arrest system shall be based on minimising the risk of injury to the user. Fall distance will vary according to the type of fall-arrest system or equipment used. A full examination of all factors likely to contribute to fall distance together with adequate provision for residual clearance shall be made.

When PSAaf systems approved and type-tested specifically for scaffolding construction work are used, with 2.0 m long **PSAaf connecting means and PSAaf belts with webbing extension**, the attachment point must be at least 1.0 m above the standing surface.

If **PSAaf belts without webbing extension** and 2.0 m long PSAaf connecting means are used, attachment is also possible at an intermediate ledger (50 cm) or at the ledger at the level of the standing surface or on the standard. Attachment at a lower point is not permissible.

The necessary clearance between the attachment point and the possible impact surface is for

PSAaf systems with webbing extension

- a1) when attached overhead: at least 5.25 m (Fig. 13)
- a2) when attached at guardrail level: at least 6.75 m (Fig. 14)

and for

PSAaf systems without webbing extension

- b1) when attached overhead: at least 4.75 m (Fig. 13)
- b2) when attached at guardrail level: at least 6.25 m (Fig. 14)

With the use of a fall-arrest system, suspension trauma may occur when a person has an arrested fall. Scaffolders or emergency response personnel must be trained in the emergency rescue procedures and be able to recognize the risks of suspension trauma and act quickly in the rescue of a person.

For selection, use and maintenance of fall-arrest systems refer to European or national regulations.



Bild 13: Attachment overhead



Bild 14: Attachment at guardrail level

WARNING

The manufacturer's instructions for use and maintenance of a fall-arrest system must be followed. Safety harnesses and lanyards must comply with, be inspected in accordance with and be used in compliance with the relevant national regulations and requirements. If the fall clearance between the attachment point and the possible impact point is less than that required, there is a risk of serious injury or death.

Layher Advance Guardrail System

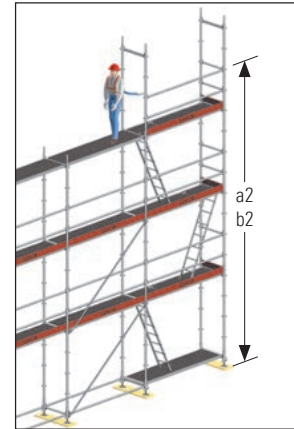
A detailed description of the use, maintenance and care of the Layher advance guardrail system (AGS) can be found in the appropriate instructions for assembly and use of this system.

The Layher end advance guardrail can be conveniently repositioned from above and below. The erector, standing on a secured level, pulls one of the cross rungs of the end guardrail downwards, or presses it down with his foot, to release the upper U-section. Then the end advance guardrail is swung outwards, moved upwards or downwards, and the lower U-section fitted onto the installed ledger. Now one of the cross rungs must be pulled downwards or pressed with a foot until the upper U-section can be swung underneath the support ledger of the deck. The end advance guardrail is secured by releasing the cross rung. To use the first level, a ledger must be installed on the lower frame. It is used for bay lengths up to 1.40 m.



Fig. 15: Assembly of end advance guardrail

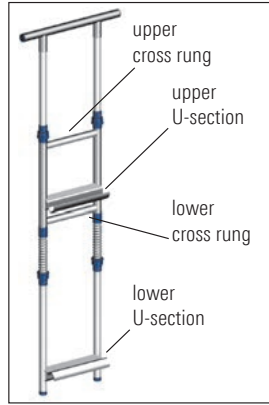
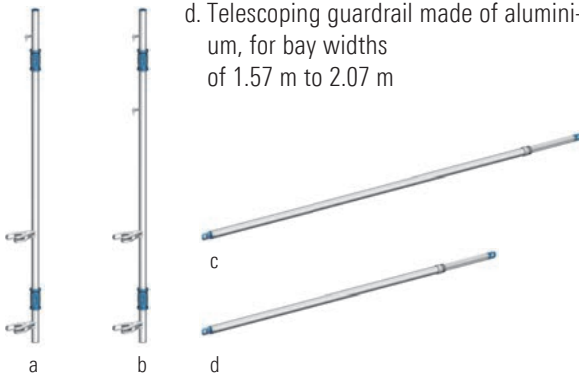

Fig. 16: Details of end advance guardrail

How the Layher advance guardrail works

The Layher advance guardrail system (AGS) consists of two basic components – advance guardrail post and telescoping guardrail. The advance guardrail post a) or b) must be used depending on local regulations.

- a. Advance guardrail post with connection for telescoping guardrail at 1 m height
- b. Advance guardrail post with connection for telescoping guardrail at 0.5 m and 1 m heights
- c. Telescoping guardrail made of aluminium, for bay widths of 2.57 m to 3.07 m and also for combined bay widths (e.g. 1.57 m and 1.09 m) by bridging a standard axis
- d. Telescoping guardrail made of aluminium, for bay widths of 1.57 m to 2.07 m



The advance guardrail post of the assembly safety rail can be fitted and dismantled by an erector from two positions:

1. Assembly/dismantling from above
2. Assembly/dismantling from below

It must be ensured that both claws of the advance guardrail snap in completely and that the telescoping guardrail is attached using the tilting pins.

Fig. 17: Connection of advance guardrail post to vertical standard



Fig. 18: Use of the advance guardrail in the access bay



Fig. 19: Detail of assembly of the advance guardrail in the access bay

Preventing falls during work on the scaffolding

Unless local regulations specify otherwise, the three-piece edge protection comprising guardrail, midrail and toe board must be installed on the outside of the scaffolding at all exposed edges of working platforms.

When overlapping scaffolding planks are used, a third ledger at the level of 1.5 m ensures the minimum guardrail height of 1 m.

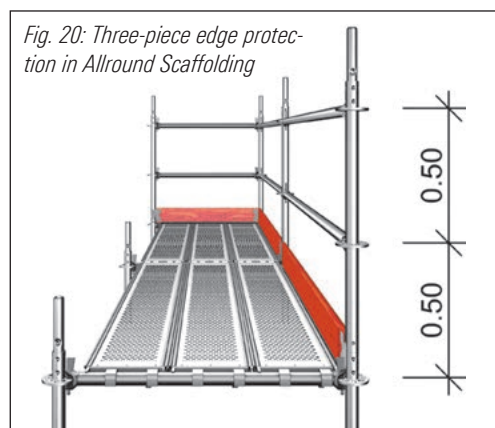

Fig. 20: Three-piece edge protection in Allround Scaffolding

If for a working face the specified maximum distance (e.g. 30 cm) between the face and the platform edge or horizontal member of the scaffold is exceeded, edge protection is necessary on the inside of the scaffolding. In individual cases, edge protection may be needed for smaller distances too. If work is to be done on the façade, the design of the edge protection must be checked.



Fig. 21: Toe board in U-section system



Fig. 22: Toe board in O-section system

3. GENERAL

Allround Scaffolding in steel or aluminium

Layher Allround Scaffolding is made of steel or aluminium. Steel and aluminium components have different load-bearing capacities. Steel and aluminium Allround equipment can be distinguished by the tube thicknesses and the colour of the stickers (steel fluorescent red; aluminium fluorescent yellow). See also page 4.

Allround Scaffolding of steel: Variants II and K2000+

The following two variants must be distinguished:

- a. Variant II
Made until 1999.
- b. K2000+
Made starting in 2000.

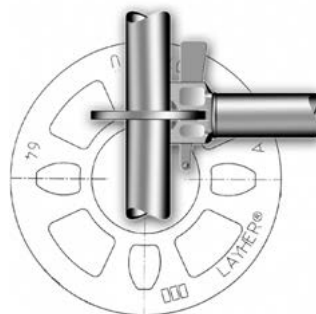

Fig. 23

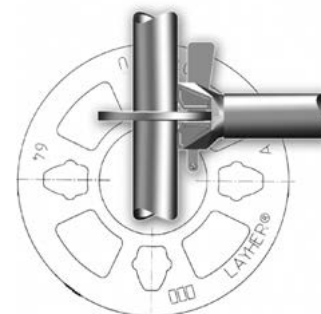

Fig. 24

Both variants have different load-bearing capacities, but can be used interchangeably. In the case of these mixed structures, the lower load-bearing capacities of variant II are applicable.

The two kinds of standards differ in the form of the “small” holes (Figs. 23 and 24). The ledgers differ in the form of the wedge-heads (Figs. 23 and 24).

Function principle of Allround wedge connection

1. Slide the wedge-head over the rosette.
2. Insert the wedge into a hole. The component is secure against shifting and falling out.
3. Hammer down the wedge to provide a non-positive connection (use 500 g metal hammer until the blow bounces off).

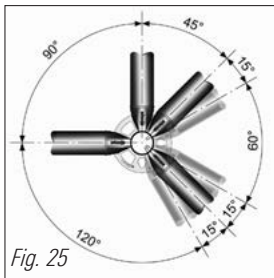
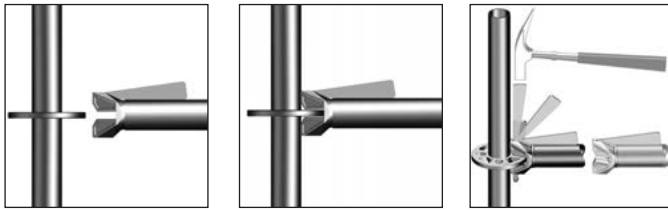

Fig. 25

The rosette allows up to 8 components to be connected. When the small holes are used, the components are automatically connected at right angles to one another. In the large holes, the connection angles are variable.

⚠ WARNING

After installation, i.e. before a load is put on the components, the wedges must be hammered home using a 500 g metal hammer to ensure a non-positive connection. The Layher hammer (Ref. No. 4421.050) may be used. Metal hammers with larger heads must not be used for knocking out wedges.

Prevent unintended disconnection of load bearing member wedges (e.g. diagonal braces) when knocking out wedges. Inadvertent disconnection of load bearing members reduce the stability of the scaffolding structure and can lead to its collapse.



Layher hammer
with tubular steel
handle
Ref. No. 4421.050

Supplementing the Allround Scaffolding with scaffolding tubes, couplers and wooden planks

The Allround Scaffolding can be supplemented with

- scaffolding tubes as per EN 39 or other local regulations
- scaffolding couplers acc. to EN 74 or other local regulations
- scaffolding planks

Scaffolding tubes can be connected using scaffolding couplers to standards, ledgers, brackets, lattice beams and other Allround components. Scaffolding tubes connected using scaffolding couplers can have both a structural function (e.g. as bracket bracing, as lattice beam bracing, as special anchoring) and be used for secondary purposes.

⚠ WARNING

Incorrectly fitted scaffolding couplers reduce the stability of the scaffolding structure and can lead to its collapse.

The wedge couplers must be hammered tight using a 500 g metal hammer until the blow bounces off. Screw couplers must be tightened with an at least 50 Nm torque.

When scaffolding planks are used, the permissible plank cross-sections, maximum spans and other criteria for use in accordance with local regulations must be complied with. Planks must be secured against inadvertent lifting off and shifting.

Scaffolding planks can be mounted in Allround Scaffolding on transoms and additional support ledgers and arranged either overlapping or abutting.

Fig. 26: Wooden planks abutting

Fig. 27: Wooden planks overlapping

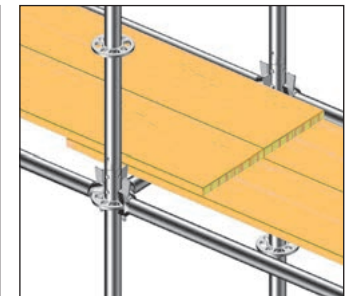
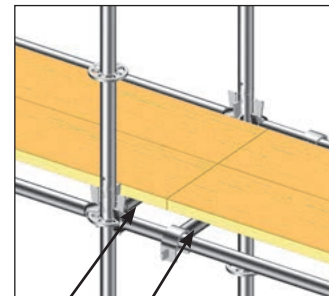

Transom Additional support ledger

Important assembly instructions

Work on the scaffolding must always be performed wherever possible on a completely assembled and secured level.

WARNING

Wedges must be hammered home immediately after assembly of the components using a 500 g metal hammer until the blow bounces off.

The wedge couplers must be hammered tight using a 500 g metal hammer until the blow bounces off. Screw couplers must be tightened with an at least 50 Nm torque.

Scaffolding may only be erected on sufficiently strong surfaces. Before assembling Layher Allround structures, the surface must be checked for sufficient load-bearing capacity. Suitable load-distributing bases must be selected.

The maximum spindle extension lengths must not be exceeded. One-sided positioning of the base plate can cause excessive stresses in its cross-section and collapse of the scaffolding.

The stability of the scaffolding must be verified and assured at any time, including all assembly status.

Anchoring must be installed continually as scaffolding assembly progresses. If necessary, stability must be assured by ballasting or bracing.

All decks installed as part of a working platform must be secured against dangerous displacement e.g. unintended dislodging or uplifting by wind forces. In scaffold structures where the shear stiffness of the decks is used for stabilizing, all decks have to be installed over the full bay width and have to be secured by lift-off preventers.

No personnel or loose objects may be on rolling towers when these are being moved. The wheels of the mobile tower must always be locked and may be released only when the tower is being moved.

Inadvertently removed wedges of load bearing braces can lead to the collapse of the scaffolding structure and result in serious injury or death.

Corrosion resistance

1. Scaffolding parts made of galvanized steel

Layher scaffolding components made of steel are largely protected from corrosion by a hot-dip galvanizing process with zinc coating thicknesses of 60 to 80 μm .

This high zinc coating thickness ensures a very long service life when the components are used in moderately polluted urban and industrial atmospheres and in coastal areas with low salt exposure. The zinc coating is, in this case, only degraded very slowly (about 0.7 to 2.1 μm a year, as per DIN EN ISO 12944), so its protective effect is correspondingly durable. In this case, special measures are not normally necessary.

In industrial areas with aggressive atmospheres and in coastal or offshore areas with high salt exposure, the zinc coating will degrade at an above-average rate (about 4.2 to 8.4 μm a year, as per DIN EN ISO 12944), so the protective effect of the zinc coating will be correspondingly shortened. Direct contact with aggressive media (e.g. acid) too might damage the zinc coating and lead to premature corrosion. When the components are used in these aggressive atmospheres, the scaffolding erector must arrange for suitable checking measures to inspect the components and to monitor the development of corrosion.

2. Scaffolding components made of aluminium

Aluminium surfaces form natural oxide coatings which largely protect the scaffolding components from corrosion (material degradation). This oxide coating is resistant in the chemically neutral range (pH 5–8). In industrial areas with aggressive atmospheres and in coastal or offshore areas with high salt exposure, as well as in cases of direct contact with acids or alkalines, visible surface defects, material degradation and hence a shortened service life of the components must be expected. When the components are used in these aggressive atmospheres, the scaffolding erector must arrange for suitable checking measures to inspect the components and to monitor the development of corrosion.

3. Direct contact of scaffolding components made of different metals

If components made of different metals (such as aluminium and galvanized steel) are in a direct conductive connection to one another and if a liquid medium (electrolyte, e.g. salt water) is additionally present,

there is a risk of contact corrosion. With this corrosion type, the less noble metal corrodes. This can occur for example in coastal/offshore areas when scaffolding couplers are attached to aluminium lattice beams. There is a risk here that aluminium can deteriorate underneath the scaffolding coupler without this being visible. When the components are used in these aggressive atmospheres, the scaffolding erector must arrange for suitable checking measures to inspect the components and to monitor the development of corrosion.

If scaffolding components are used in the corrosion-promoting environments described above, the responsibility for any consequences associated with them lie with the scaffolding erector.

- ▶ Layher scaffolding components are corrosion-resistant for many years under normal atmospheric conditions.
- ▶ When used in industrial areas with aggressive atmospheres and in coastal or offshore areas with high salt exposure, or in cases of contact with aggressive media, scaffolding components can corrode faster than under less aggressive conditions.
- ▶ If components made of different metals are in a direct conductive connection to one another, there is a risk of contact corrosion (for example in offshore applications in the pairing „galvanized steel/aluminium“).

4. BASIC COMPONENTS OF LAYHER ALLROUND SCAFFOLDING

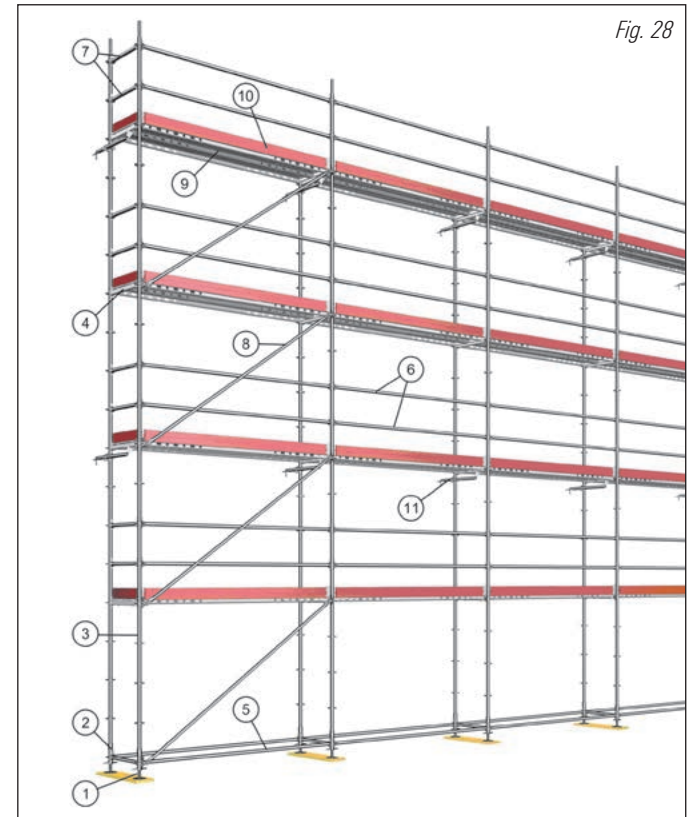

Fig. 28

- 1 Base jacks
- 2 Base collar
- 3 Standard
- 4 Support ledger (U-ledger or O-ledger)
- 5 O-Ledger
- 6 Guardrail (O-ledger)
- 7 End guardrail (O-ledger)
- 8 Diagonal brace
- 9 O-/U-Scaffolding deck
- 10 Toe board
- 11 Anchoring

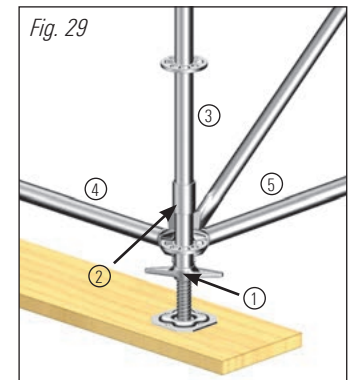

Fig. 29

Base jacks, base plates

The base jacks must be in full surface contact. If necessary the base jacks must be secured against sliding.

WARNING

One-sided positioning of the base jack can cause excessive stresses in its cross-section and collapse of the scaffolding.

Adjustable base jack type and extension length

Adjustable base jacks with the biggest maximum spindle adjustment may be used provided their load-bearing capacity is ensured in each case. If the surface is not level, swivelling base jacks or wedge-type inserts must be used and secured against sliding.

Load capabilities of base jack cross-section as per EN 12811-1

Base jack type	N _{pl,d} [kN]	M _{pl,d} [kNcm]	V _{pl,d} [kN]
normal	97.7	83.0	36.0
reinforced	119.9	94.5	44.1
solid	288.0	157.0	106.0

Base collars

The base collars with rosettes are fitted over the height-adjustable base jacks and are suitable for forming the base. In special cases the base collars can be dispensed with.

Standards

The Allround standards are provided with rosettes at every 50 cm. They are available in lengths of 0.5 m, 1 m, 1.5 m, 2 m, 2.5 m, 3 m and 4 m. The small openings in the rosette determine right-angled connections; the large openings permit connections at any angle.

Ledgers

Ledgers serve as transoms, bracing elements and guardrails. The wedge lock connection ensures a positive and non-positive connection with central load introduction between the standards and ledgers.

Assembly variation 1

See page 16 for explanation of the Allround wedge-head connection.

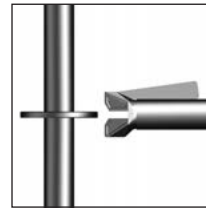

Fig. 30

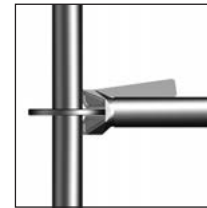

Fig. 31

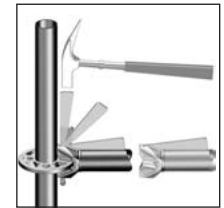

Fig. 32

Assembly variation 2

This variation provides adequate safety when using longer ledgers. The far end is laid with the wedge projecting through the rosette. This prevents slippage of the ledger. The near end is slipped onto the rosette and the wedge dropped into place. The wedge at the far end is lifted out of rosette allowing the head to be slipped onto the rosette and secured. Both wedges are hammered home.

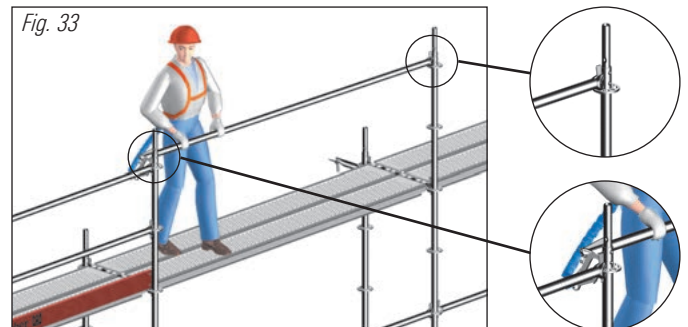

Fig. 33

Scaffolding deck

Allround Scaffolding system decks – U-section and O-section

The scaffolding decks shown in these instructions for assembly and use are intended to act as examples and represent a cross-section from the Layher range. Further scaffolding decks can be found in the Allround Scaffolding catalogue. The decks must be selected to sustain the planned loads.

In the case of Layher system decks, two basic suspension variants are distinguished, resulting in different variants of support ledgers for brackets, ledgers, bridging ledgers etc.

The result is two modular scaffolding systems designated in the following as the U-profile and O-profile variants. All assembly sequences in these instructions are shown with O-profiles; the assembly sequence with U-profiles is identical. With U-profiles, lift-off preventers are needed as additional parts. In all cases, the decks must be secured against lifting off, and it must be ensured that the decks are firmly in place with all their claws.

Parts differing in the O-profile and U-profile systems are listed with the designation U-component name or O-component name (see Annex).

Decks for mounting on U-profiles

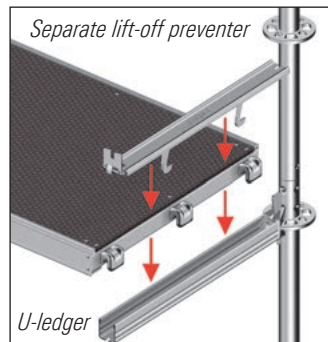

Fig. 34

Decks for mounting on O-profiles

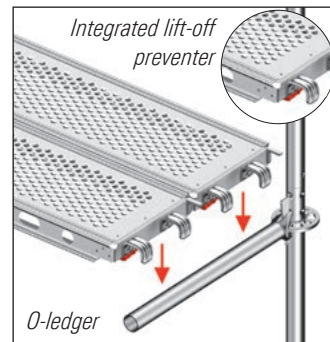

Fig. 35

Installation of decks for mounting on O-profiles

O-steel decks old production

1. Swing back lift-off preventer.
2. Lay deck on ledger.
3. Swing lift-off preventer forward.

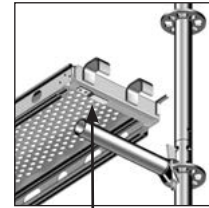

Fig. 36

Lift-off preventer

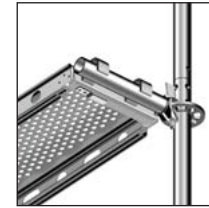

Fig. 37

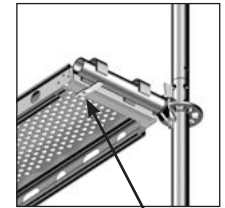

Fig. 38

secured

O-steel decks current production

1. Swing back lift-off preventer.
2. Lay deck on ledger.
3. Swing lift-off preventer forward.

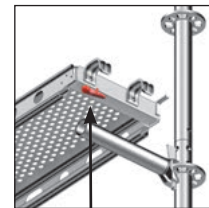

Fig. 39

Lift-off preventer

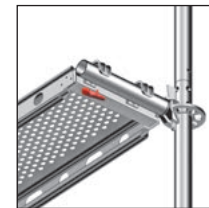

Fig. 40

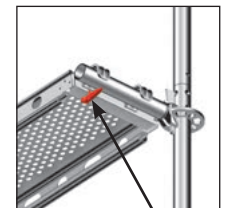
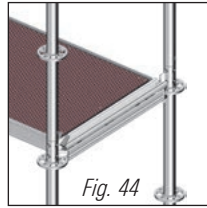
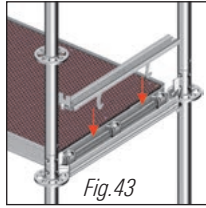
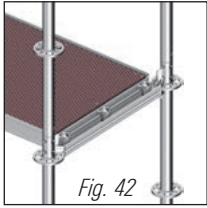

Fig. 41

secured

Installation of decks for mounting on U-profiles

1. Lay deck inside U-profile.
2. Tilt back movable end of lift-off preventer.
3. Place lift-off preventer inside U-profile, inserting the hooks of the lift-off preventer into the recesses in the U-profile.



4. Move the lift-off preventer until the hooks engage.
5. Fold the moving end downwards.

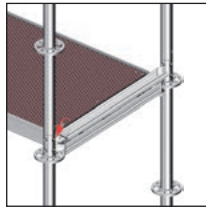
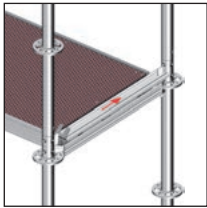

left: Fig. 45
right: Fig. 46

WARNING

All decks installed as part of a working platform must be secured against dangerous displacement e.g. unintended dislodging or uplifting by wind forces. In scaffold structures where the shear stiffness of the decks is used for stabilizing, all decks have to be installed over the full bay width and have to be secured by lift-off preventers.

Depending on the length chosen for support ledgers, combinations of decks with widths of 0.19 m, 0.32 m and 0.61 m must be used to cover the entire area.

U-ledger deck configuration

0.45 m	1 x 0.32 m
0.50 m	2 x 0.19 m
0.73 m	2 x 0.32 m or 1 x 0.61 m
1.09 m	3 x 0.32 m or 1 x 0.61 m + 1 x 0.32 m
1.40 m	4 x 0.32 m or 2 x 0.61 m
1.57 m	4 x 0.32 m and 1 x 0.19 m
2.07 m	6 x 0.32 m
2.57 m	7 x 0.32 m and 1 x 0.19 m
3.07 m	9 x 0.32 m or 8 x 0.32 m + 2 x 0.19 m

Diagonal braces

The diagonals with wedge-heads further brace the basic system consisting of standards and ledgers, and due to their high connection values facilitate safe, rigid and wobble-free scaffolding. They must be installed according to structural strength requirements.

NOTE

Diagonal braces should be installed on the outside of the scaffold wherever possible. This will assist with the use of horizontal advanced guardrail techniques and make installation of the working platform easier. It also helps reduce the risk of unintentional dislodging of the wedge.

Toe board

The toe board completes the three-piece edge protection on the outside of the scaffolding.

5. FAÇADE SCAFFOLDING

Caution: Check the surface for sufficient load-bearing capacity, and lay out suitable sole plates. The maximum adjustable base jacks extension length must not be exceeded. When positioning, the maximum wall clearance must be ensured to prevent any risk of falls at the upper levels.

Fig. 47

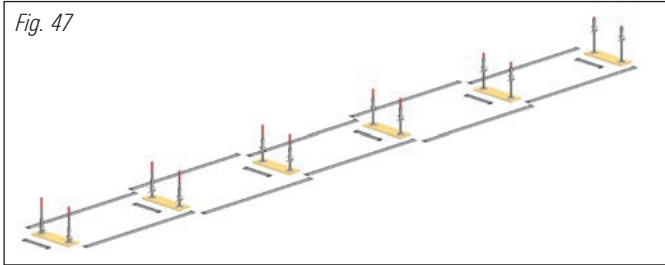

1. Assembly should be started at the highest ground level (refer to section 19). In the first step, longitudinal ledgers and transoms must be laid out.
2. Place sole plates where standards are required.
3. Position base jacks with attached vertical base collars on the sole plates.
4. Connect ledgers in the small holes in the rosettes. Align the base of the scaffolding accordingly and level the scaffold using a spirit level.

Caution: When positioning, stay within the maximum clearance from the wall, otherwise there is a risk of falling.

Fig. 48

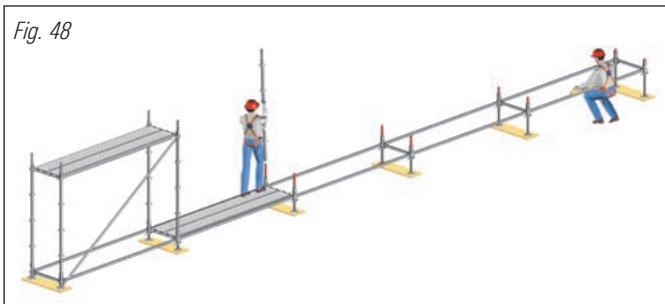

5. Then insert decks in the access bay.
6. Fit vertical standards. Install transoms.
7. Insert decks, secure them against lifting out, and stiffen the scaffolding with vertical diagonal braces. Stiffen at least every fifth bay with vertical diagonal braces. Preferably diagonal braces should be installed on the outside of the scaffold.
8. If necessary, the planks must be installed in the scaffolding.
9. Insert the access deck and the remaining steel decks, then close the lift-off preventer. Knock in the wedges.

Fig. 49

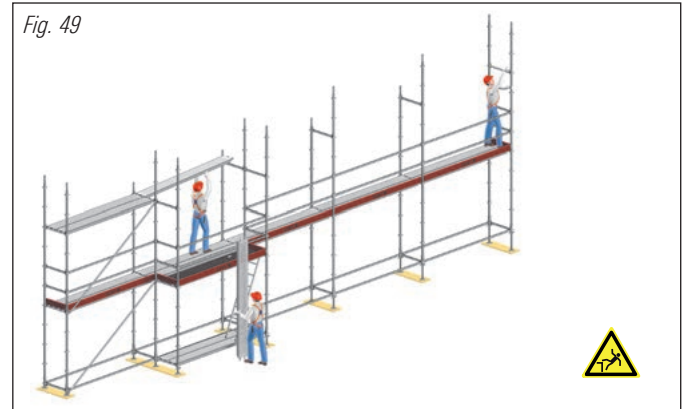

10. Fit vertical standards on the next level.
11. Fit three-piece edge protection comprising guardrail, midrail and toe board.
12. Attach vertical diagonal braces. Preferably diagonal braces should be installed on the outside of the scaffold.
13. Fit access deck and steel decks, then close the lift-off preventer. Knock in the wedges.
14. **Caution:** Attach the necessary anchoring continually as scaffolding assembly progresses. Refer to the anchoring section.
15. **Caution:** Keep the hatches in access decks closed at all times! Only open them when needed and close them again immediately afterwards!

Fig. 50

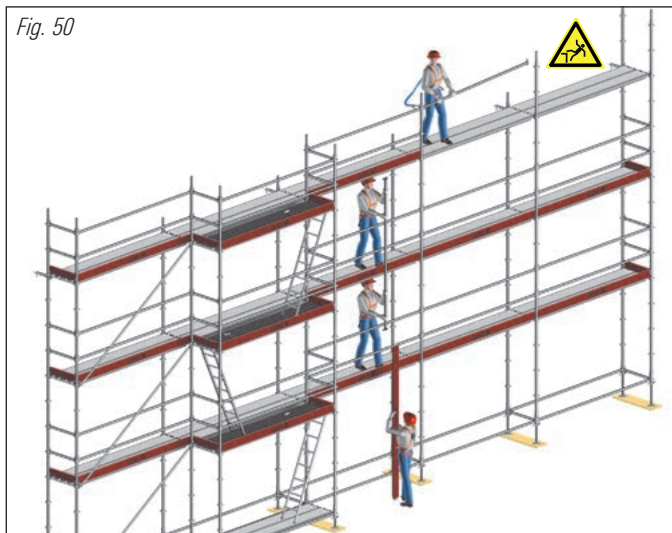

16. **Caution:** Complete the top working level with three-piece edge protection at the edges at risk from falls.

Fig. 51



Assembly of the further scaffolding levels

Depending on the risk analysis, for scaffolding more than 8 m high (deck height above ground surface), building hoists should be used for assembly, modification and dismantling. As an exception to this, hoists can be dispensed with if the scaffolding height is no more than 14 m and the overall length of the scaffolding is no more than 10 m. For manual handling, a worker must stand at each level depending on the components being moved.

Caution: There is a risk of falls during assembly of the further scaffolding levels. Measures ascertained in the risk analysis performed by the scaffolding erector must be applied.

Fig. 52

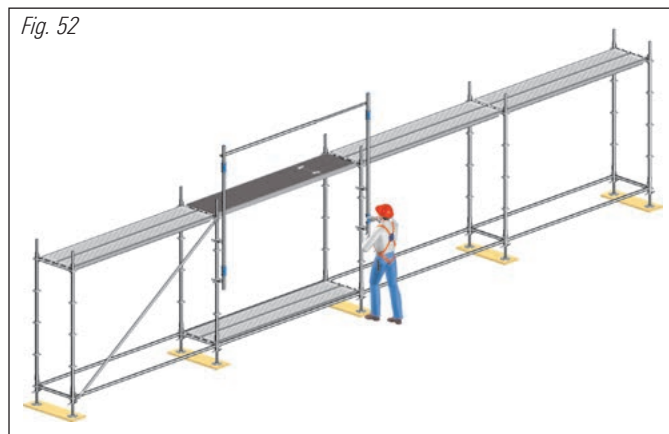

Diagonal bracing options

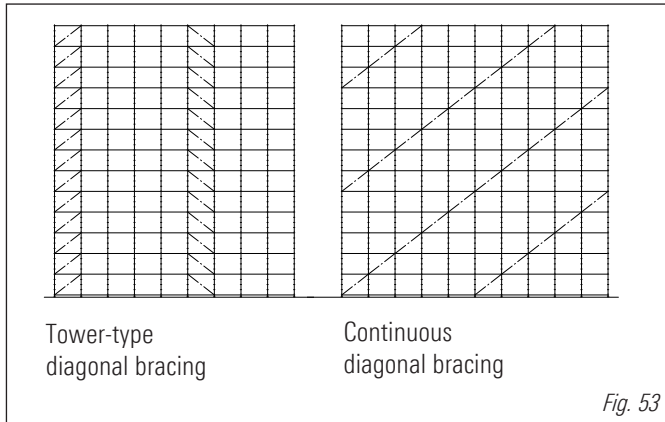

WARNING

Missing diagonal braces and/or horizontal ledgers reduce the stability of the scaffolding structure and can lead to its collapse.

6. TOWER SCAFFOLDING

Tower scaffolding is used extensively for inspection work in industrial plant and shipyards etc., as mobile towers (supplemented by Layher rolling tower wheels, see section on Mobile Scaffolding Units), as the basis for birdcage scaffolding, or for propping vertical loads as support scaffolding (supplemented by Layher head jacks). The automatic rectangularity of Layher Allround equipment permits rapid and hence economical assembly and dismantling of this frequently used scaffolding type.

Caution: Check the surface for sufficient load-bearing capacity and lay out suitable sole plates.

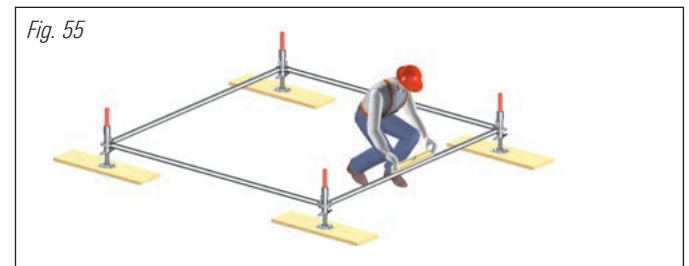
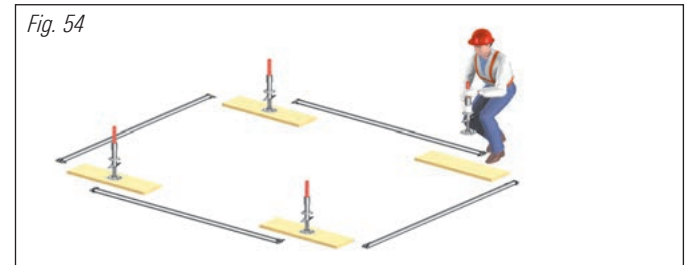

1. Lay out ledgers and place sole plates at the corners.
2. Position base jacks with attached base collars on sole plates.
3. Connect ledgers in the small holes of the rosettes, align the base of the tower accordingly and level the scaffolding using a spirit level.

Fig. 56

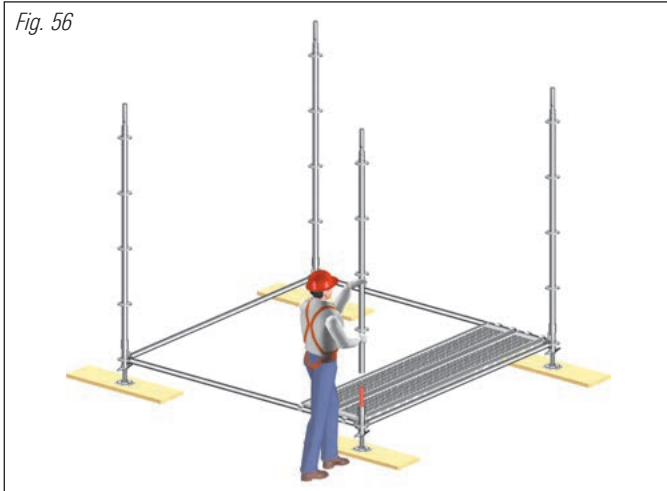

4. Insert decks in the access area.
5. Fit vertical standards.
6. Fit ledgers.

Fig. 57

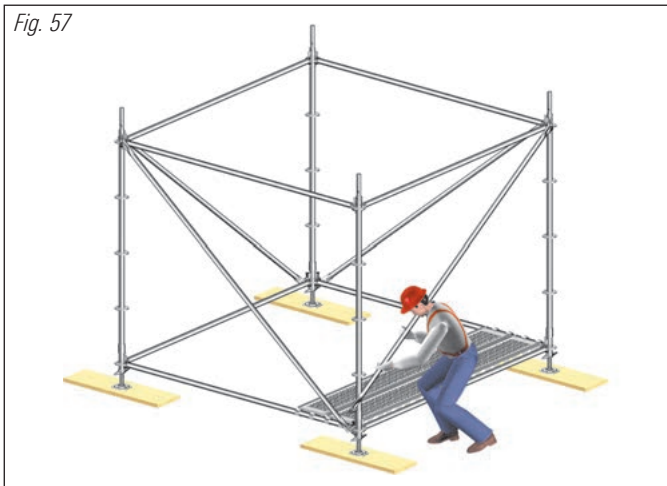

7. Stiffen all 4 sides of the scaffolding using vertical diagonal braces. Insert decks. Preferably diagonal braces should be installed on the outside of the scaffold.
8. Knock in the wedges.

Fig. 58



9. Additional levels must be constructed in accordance with the scaffolding erector's risk assessment.
10. Knock in the wedges.
11. Install vertical diagonal braces on all 4 sides of the intermediate level. Preferably diagonal braces should be installed on the outside of the scaffold.
12. Attach support ledgers as edge protection on the inside of the access deck in the intermediate level. Knock in the wedge to prevent the support ledger from shifting!
13. On the working level, install the three-part edge protection all around the perimeter.

The stability of the tower must be verified in each specific case. If necessary, stability must be assured by anchoring, ballasting, bracing or widening of the scaffolding.

7. BIRDCAGE SCAFFOLDING

Birdcage scaffolding can be used to cover ceilings, and is also used as support scaffolding. Assembly is similar to that for tower scaffolding, with particular attention being given to bracing of the scaffolding structure. Check the surface for sufficient load-bearing capacity, and lay out suitable sole plates.

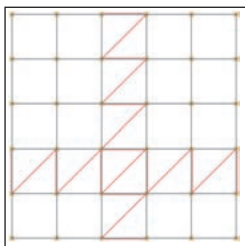
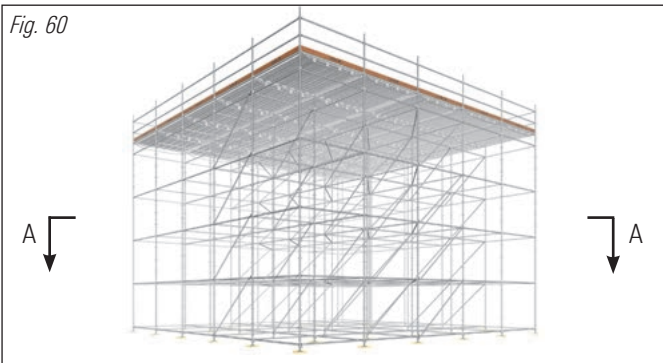
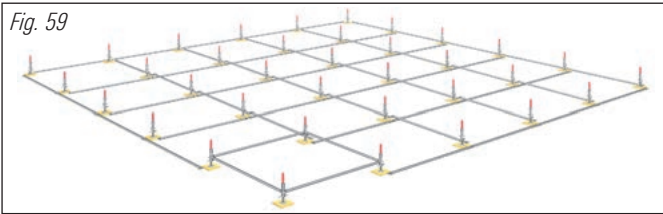

Fig. 61 Section A-A

Arrange the vertical diagonal braces so that every axis of the birdcage scaffolding is stiffened by a brace in at least every fifth bay. Furthermore, use horizontal diagonal braces or, for example, decks (see section A-A) to ensure that the horizontal scaffolding levels are braced too.

Caution: Stiffening in every fifth bay is the minimum required; resistance to greater loads requires a denser arrangement of diagonal braces.

8. SUPPORT SCAFFOLDING

With Layher Allround equipment, support scaffolding can be put up quickly and economically for the safe transfer of loads.

Caution: Check the surface, and lay out sole plates suitable for transferring the loads.

Support scaffolding, e.g. for concreting of floors

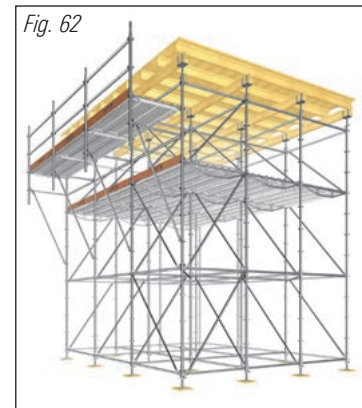

1. Falsework, for example when concreting floors, is erected in the same way as tower and birdcage scaffolding.
2. At the top level, use vertical braces without spigots.
3. Fit head jacks onto the vertical standards.

Caution: The load-bearing capacity for the transfer of loads must be verified, with particular attention to stiffening with vertical diagonal braces, the bay width and the spindle adjustment of the base jacks and head jacks. Preferably diagonal braces should be installed on the outside of the scaffold.

Caution: The loads of the formwork supports must pass centrally into the head jacks. The formwork supports must be prevented from tilting.



Fig. 63
Adjustment plate for
base jacks

The length of the vertical standards must be selected so that the adjustable base jacks and head jacks are extended as little as possible. If bracing of the spindles is necessary, a wedged swivel coupler with spindle insert must be used.

Fig. 64

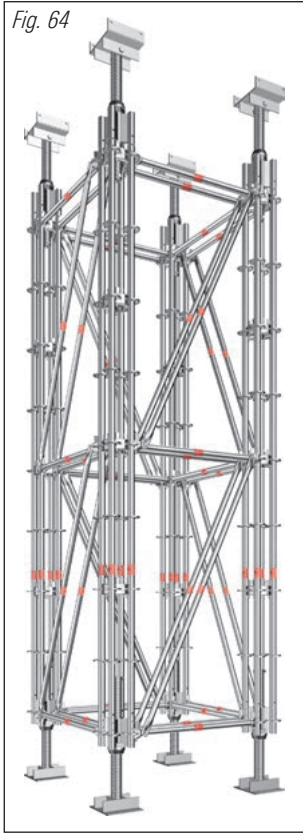

Heavy-duty tower

Heavy-duty tower for transfer of high individual loads, made from standard material using the following additional parts:

- Head jack for heavy-duty tower
- Heavy-duty 4 way head collar
- Twin wedge coupler
- Heavy-duty 4 way base collar
- Base for heavy-duty tower

Fig. 65

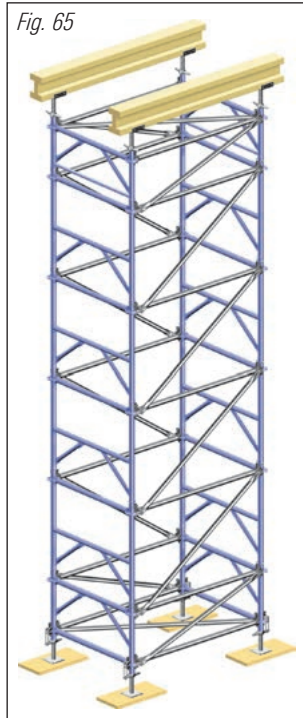

For efficient, quick and safe construction of support scaffolding, we recommend the Allround shoring frame TG 60. See instructions for assembly and use.

9. CIRCULAR SCAFFOLDING

Thanks to 8 possible connections and variable angle selection, curved surfaces can be enclosed with scaffolding without any problem. The following distinction is useful here:

Small diameter = rectangular scaffolding supplemented with Layher steel planks.

Large diameter = use of variable angle selection by connection to the Allround rosette

Check the surface for sufficient load-bearing capacity and lay out suitable sole plates. These sole plates must extend over both uprights.

Enclosing structures with small diameter

Fig. 66

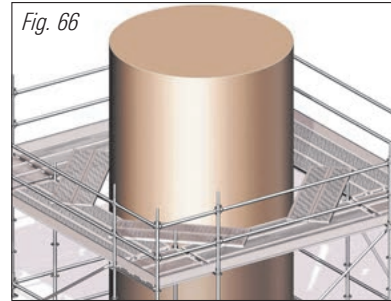

1. Lay steel planks at the inside corners.
2. The support length of the steel plank when secured by at least two locking pins at each support should be at least 10 cm.

Fig. 67



Fig. 68

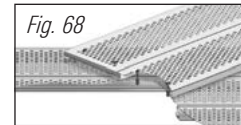

As alternative to the locking pin, it is possible to use the Layher securing screw. It must be screwed through two matched punched holes of the steel deck and the plank.

When using the securing screw, 1 screw per support is sufficient.

Fig. 69

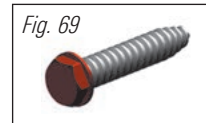

Scaffolding around an oil tank with large diameter

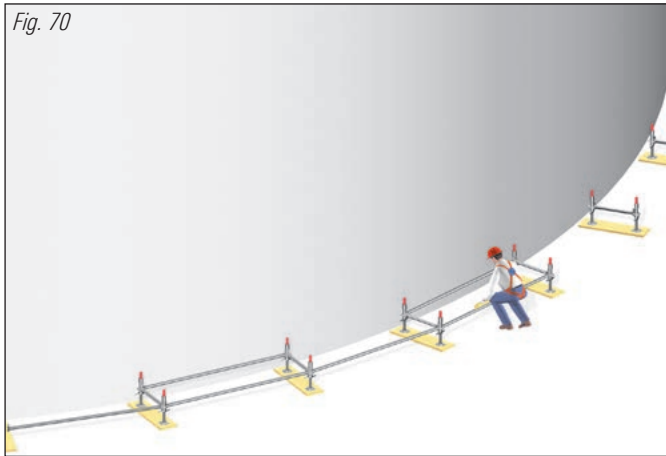

1. Lay the ledgers to match the curvature of the round tank.
2. Lay sole plates, and position base jacks with attached base collars.
3. Align the base of the scaffolding with the tank and level using a spirit level.

Caution: When positioning, stay within the maximum clearance from the wall, otherwise there is a risk of falling.

Tip: Depending on the radius, it is an advantage to insert all ledgers into the large holes (see solution 1) or only the ledgers of the intermediate bays (see solution 2).

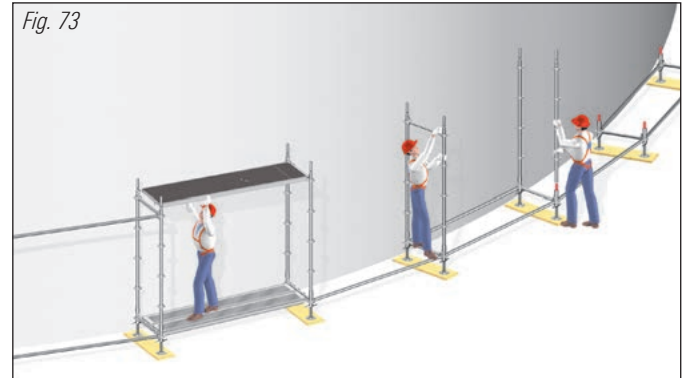
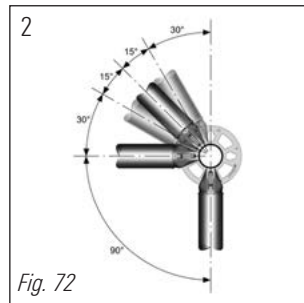
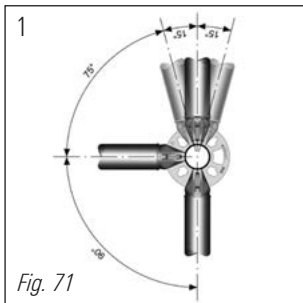

4. Fit vertical standards.
5. Insert decks as ladder bearing surface in the access bay.
6. Fit transoms.
7. Insert access deck.

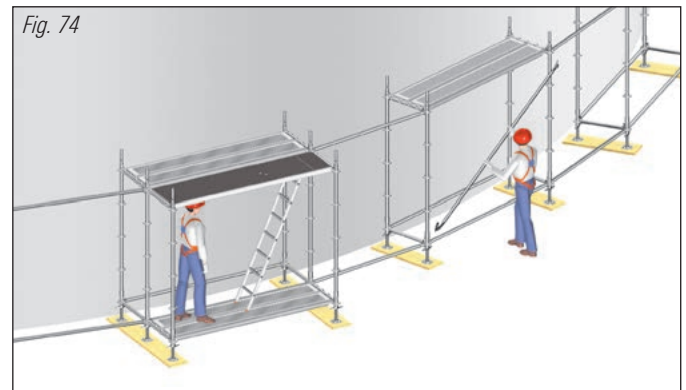

8. Insert decks in rectangular main bays, close the lift-off preventer.
9. Stiffen at least every fifth bay with vertical diagonal braces. Preferably diagonal braces should be installed on the outside of the scaffold.
10. Attach ledgers for intermediate bays.
11. Knock in all wedges.

12. Lay steel planks in the intermediate bays, not exceeding their permissible span. As soon as the minimum guardrail height is not attained, a third ledger at the 1.50 m level is needed.

Fig. 75

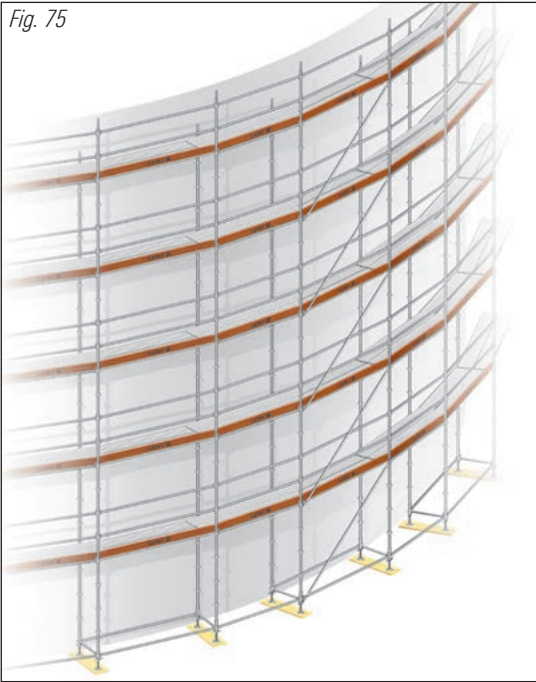

13. Repeat these assembly steps until the required height has been reached.

Caution: Anchoring must be installed continually while scaffolding assembly progresses.

10. SUSPENDED SCAFFOLDING

To minimize the amount of material used for scaffolding at great height or when the ground is not sufficiently strong and is not usable for assembly, work surfaces can be made accessible by suspended scaffolding structures. Suspended scaffolding is used in a wide variety of versions, so the following assembly sequence is intended as an example.

Suspended scaffolding can be suspended in a variety of ways. Suspension from ceilings or other structural components is possible using wall-plugs, suspended scaffolding couplers, clamping couplers, beam grippers and chains. Load capacity of the support systems must always be verified separately.



Caution: For suspended scaffolding, vertical standards with bolt-in spigots must be used for sustainable transfer of the tension forces.

The bolt-in spigots must be secured either with four M12 bolts or hinged pins.

Fig. 76: Bolt-in spigot

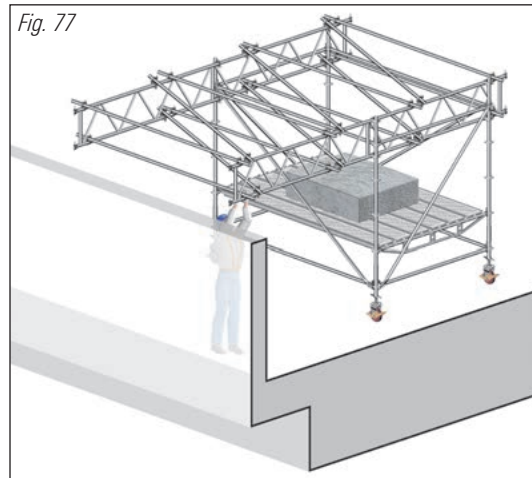

Fig. 77

1. Assemble the ballasted tower scaffolding.

The necessary ballast must be ascertained by a structural strength calculation. Safety measures must be considered in accordance with local regulations. Only solid materials may be used as ballast.

2. Connect the lattice beams to the tower scaffolding and stiffen them with tube/coupler braces at the top and bottom chords.
3. Slide the tower scaffolding up to the edge so that the ends of the lattice beams extend beyond it.

Fig. 78

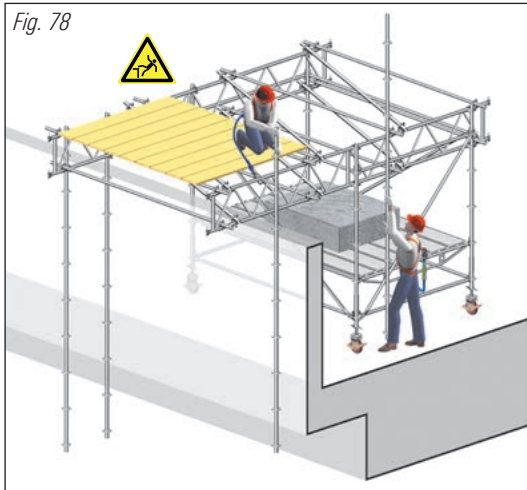

4. Lay the temporary working platform, in compliance with their maximum span.

WARNING

Risk of falls. Perform these working steps only with an approved fall-arrest system, if identified by risk assessment as a suitable means of controlling the risk of fall.

5. Use a Layher double coupler to connect vertical standards to the upper and lower chords of the lattice beam at the specified distance (if necessary using a transom as an assembly aid). Secure the double couplers with check couplers.

Tip: Install the vertical standards upside down, this makes later connection of further suspended vertical standards easier.

Fig. 79

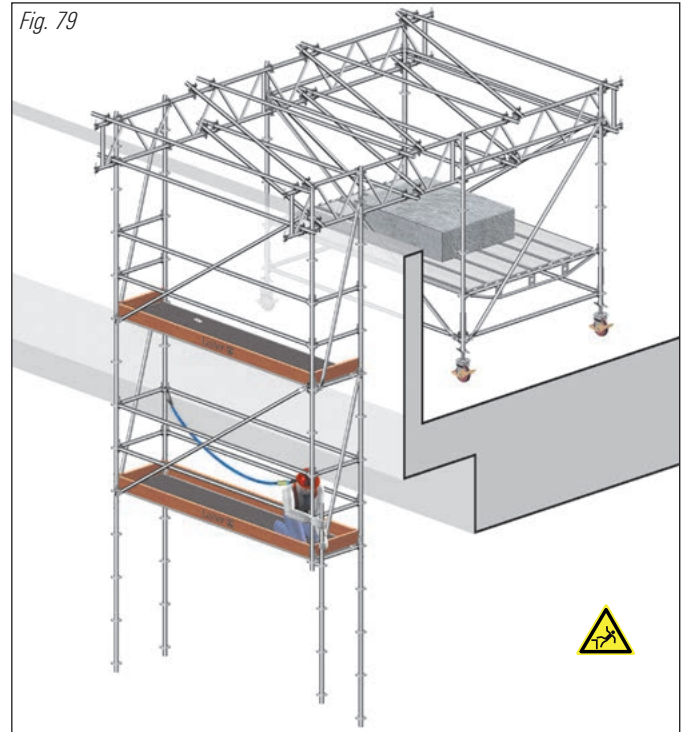

6. Go to the level underneath.
7. Fit horizontal ledgers and insert decks.
8. Install the three-part edge protection.
9. Fit vertical diagonal braces on 3 sides. Preferably diagonal braces should be installed on the outside of the scaffold.
10. Connect vertical standards with bolt-in spigots and secure them with 2 screws M12 or with 2 hinged pins.

Repeat the working steps until the necessary depth has been obtained.

Fig. 80

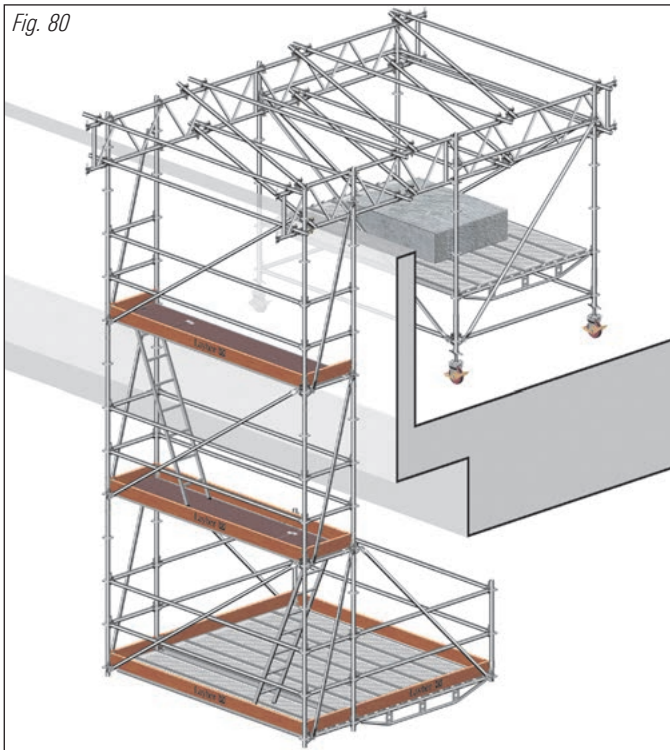

WARNING

There is a risk of falls during assembly of the further scaffolding levels. Measures ascertained in the risk analysis performed by the scaffolding erector must be applied. Keep the hatches in access decks closed at all times! Only open them when needed, and close them again immediately afterwards!

11. Assemble the projecting part as described in the section on brackets and cantilevers.
12. Install the three-part edge protection.

Tip: Alternatively to the assembly sequences shown, individual segments (e.g. the suspended part) can be preassembled on the ground and then attached to the projecting section using a crane. This reduces the risk of falls. The work must be performed so that the time spent in activities where there is a risk of falling is as short as possible.

11. MOBILE SCAFFOLDING UNITS

The use of mobile scaffolding units allows work on large areas with a small amount of material. Mobile scaffolding units can be provided with wheels to make them into rolling towers, or designed as crane-movable units.

Rolling towers

Caution: No personnel or loose objects may be on rolling towers when these are being moved. Rolling towers may only be moved by exerting force on their base, never on the upper part of the structure. The wheels of the mobile tower must always be locked unless the tower is being moved. Mobile towers may only be moved on flat surfaces.

Fig. 81

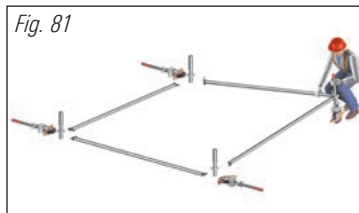

1. Lay the ledgers at right angles to one another, and lay the extended base collars at the ends.
2. Place wheels at the ends.

Caution: The wheels must be locked when the rolling tower is being assembled.

3. Connect the first two ledgers in the small holes of the base collar and insert the wheel.
4. Connect in sequence the base collars, wheels plus ledgers, but do not knock in the wedges.
5. Align the foot/base of the rolling tower using a spirit level.
6. Install steel decks in the access area and secure them against lifting out. Knock in the wedges.
7. Place standards on the vertical base collars.
8. Continue installation as with scaffolding towers.



Crane-movable units

If rolling towers cannot be used, for example due to uneven ground, scaffolding units can be designed for movement by crane. Suitable crane suspension devices must be used. Crane-movable scaffolding units can also be used when work method calls for modular pre-assembly and connection of units.

Caution: The implications of loads imposed to the scaffolding structure whilst craning must be analysed independently. Lifting and craning operations must be supervised by a qualified person.

WARNING

The joints of the vertical standards must be firmly connected to one another. It must be checked whether vertical standards with bolt-in spigots or standards with pressed (crimped) spigots and locking pins are being used.

The base jacks must be prevented from falling out.

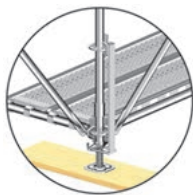

Fig. 83: Base jacks attachment with wedge-head

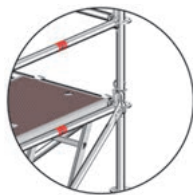

Fig. 84: Connection of vertical standards with locking pin

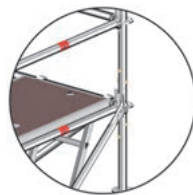

Fig. 85: Connection of vertical standards with bolt-in spigot

Caution: The stability of each mobile scaffolding unit must be verified individually. If necessary, stability must be assured by anchoring, ballasting, bracing or widening of the scaffolding.

12. ANCHORING

Caution: Anchoring is essential for the stability of the scaffolding and must be continually installed as scaffolding assembly progresses.

Only provide anchoring on sufficiently strong components, if necessary testing the anchoring surface by pull-out tests. A check can be dispensed with if sufficient load-bearing capacity can be assessed on the basis of professional experience and the service value of the anchoring force A_{\perp} does not exceed 1.5 kN or in the case of reinforced concrete according to DIN 1045, 6.0 kN. Provide evidence for the load-bearing capacity of all fastening devices (anchors, ring screws, wall plugs) for the anchoring forces.

WARNING

Absent or insufficiently strong anchoring reduces the stability of the scaffolding structure and can lead to its collapse. Anchoring may only be installed and removed by the scaffolding erector.

The scaffolding can be anchored using the following aids.

Anchoring with wall plug and ring screw in walls

- Allround wall tie
- Wall tie, short, with 1 double coupler on the inner standard
- V-type anchor with wall ties
- Wall tie, long, with 2 double couplers on 2 standards
- O-ledger

Anchoring on support structures using clamping couplers and tube/coupler structures

- Anchoring on vertical components
- Anchoring on horizontal components

The anchorings shown differ in load capacity and are not interchangeable without a renewed inspection!
Wall ties and other tube and coupler anchorings must be attached directly adjacent to the stiffened rosettes.

Allround wall ties only in conjunction with U-profile

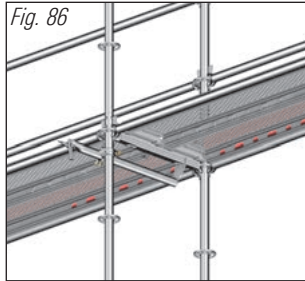

1. Connect Allround wall tie with double coupler to standard, inserting the wall tie into the ring screw.
2. The rear end of the Allround wall tie must enclose the U-section.

Wall tie, short, with one double coupler

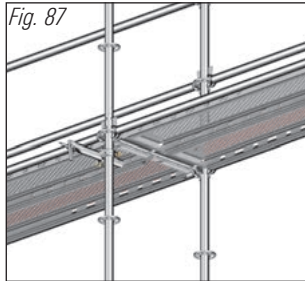

1. Connect short wall tie with double coupler to inside standard, inserting the wall tie into the ring screw. This type of anchoring cannot transmit parallel forces to the façade.

V-type wall ties

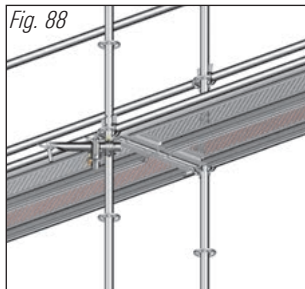

1. Connect wall tie with double coupler to standard, inserting the wall tie into the ring screw.
2. Connect second wall tie with double coupler to first wall tie, inserting the wall tie into the ring screw.
3. Alternatively: Connect both wall ties to the standard.

Wall tie, long (up to 1.75 m) with 2 double couplers

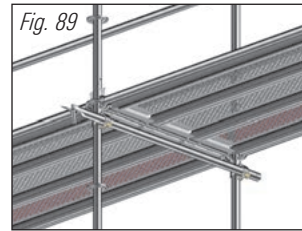

1. Connect wall tie with 2 double couplers to both standards, inserting the wall tie into the ring screw.

O-ledger with 2 standard couplers

With very wide scaffolding structures, it may be necessary to anchor with the aid of an O-ledger.

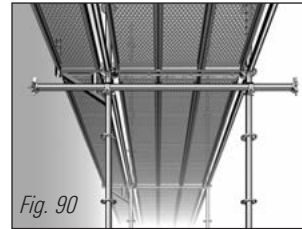

1. Connect ledger with double couplers to both standards, sliding the wedge-head over the ring screw.
2. Push the wedge through the ring screw and secure it by a hammer blow.

Anchoring on vertical components

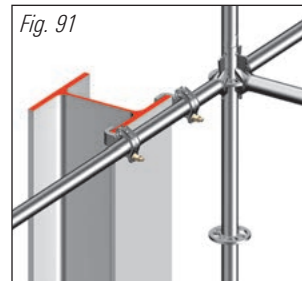

Anchoring on steel supports with the aid of clamping couplers.

1. Attach clamping couplers lightly to the scaffolding tube, then slide them up to the flange of the support.
2. Couplers must firmly enclose the flange.
3. Tighten the couplers.

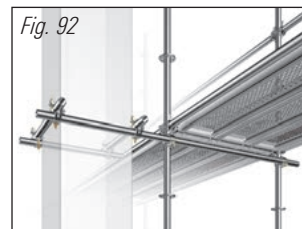

Anchoring on concrete supports or jacketed supports by tube/coupler structure. Tighten all couplers.

Anchoring on horizontal components

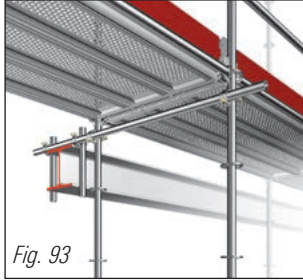

Anchoring on horizontal beams using tube/coupler structure, in the case of steel beams with the aid of clamping couplers. Assembly sequence corresponding to those for anchoring on steel or concrete supports.

Anchoring configuration

The selection of the anchoring configuration depends on the bay width, the load on the scaffolding, live load, wind load and the structural height of the scaffolding. The anchoring configuration must be selected with due consideration of these factors. Three typical anchoring configurations are shown here as examples.

As the load on the scaffolding increases, the anchoring configuration must become denser in order to transfer the forces safely into the anchoring surface. The denser the anchoring configuration, the lower the forces on the individual wall ties.

Anchoring is particularly important if the scaffolding is covered with nets or tarpaulins. Subsequent covering requires additional anchoring.

Fig. 94: Anchoring configuration every 8 m, staggered by 4 m in the vertical.

Anchor the standards to the scaffolding end at every 4 m. Anchor the remaining standards as shown. Vertical anchor spacing should be 8 m, staggered by 4 m in adjacent axes.

Fig. 95: Anchoring configuration every 4 m. Standards anchored every 4 m in the vertical.

Fig. 96: Anchoring configuration every 2 m. Standards anchored every 2 m in the vertical. Dense anchoring configuration for high wind loads (e.g. tarpaulin covering).

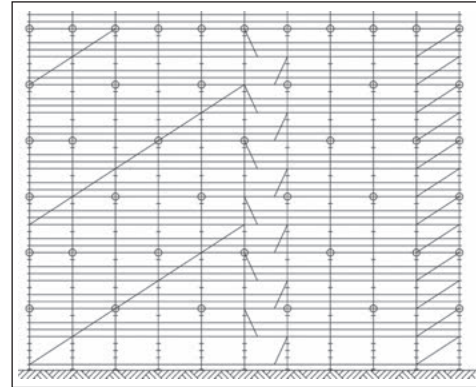

Fig. 94: Anchoring configuration every 8 m, staggered by 4 m in the vertical.

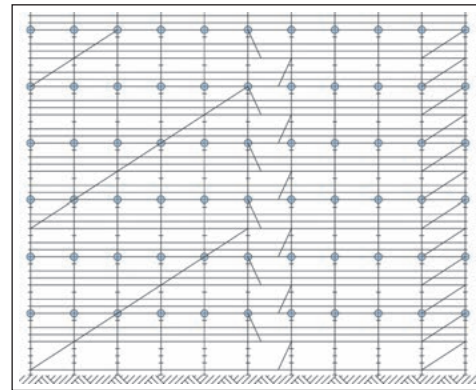

Fig. 95: Anchoring configuration 4 m

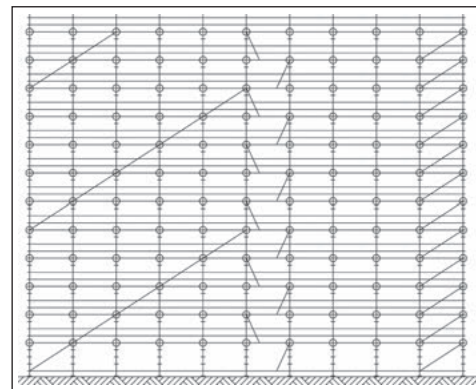

Fig. 96: Anchoring configuration 2 m

13. ACCESSES

To prevent falls and hazards for health and safety, Layher recommends the use of external landing-type stairway accesses, especially when

- material is transported through the access,
- the height of access exceeds more than 10 m or
- extended working is done from the scaffolding.

Landing-type stairway access in façade scaffolding

1. An additional outer bay is fitted to the scaffolding as described under section 5.
2. Lay the landing-type stairway over the transoms, and close the lift-off preventer.

Fig. 97

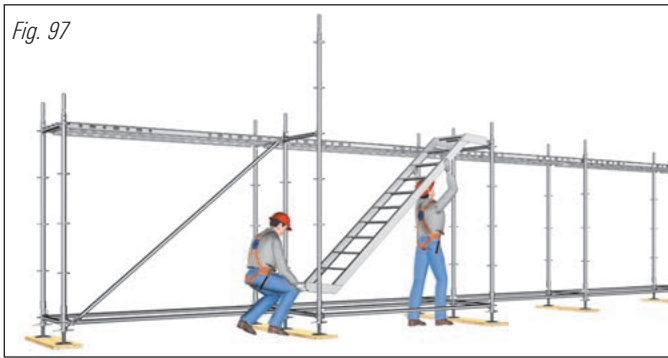

3. At the entry to the landing-type stairway, fit two stairway guardrail adaptors to the rosettes on the outer standard.
4. Attach standards and then fit ledgers.
5. Place the stairway guardrail at the top over the ledgers and at the bottom over the stairway guardrail adaptors.
6. Fit stairwell guardrail.
7. Fit second scaffolding level, refer to section 5.
8. Fit next landing-type stairway, refer to item 2.
9. At the exit from the landing-type stairway, connect two stairway guardrail adaptors to the rosettes on the outer standard.
10. Place the stairway guardrail at the bottom over the O-ledgers and at the top over the stairway guardrail adaptors.
11. Fit the three-piece side protection.

Fig. 98

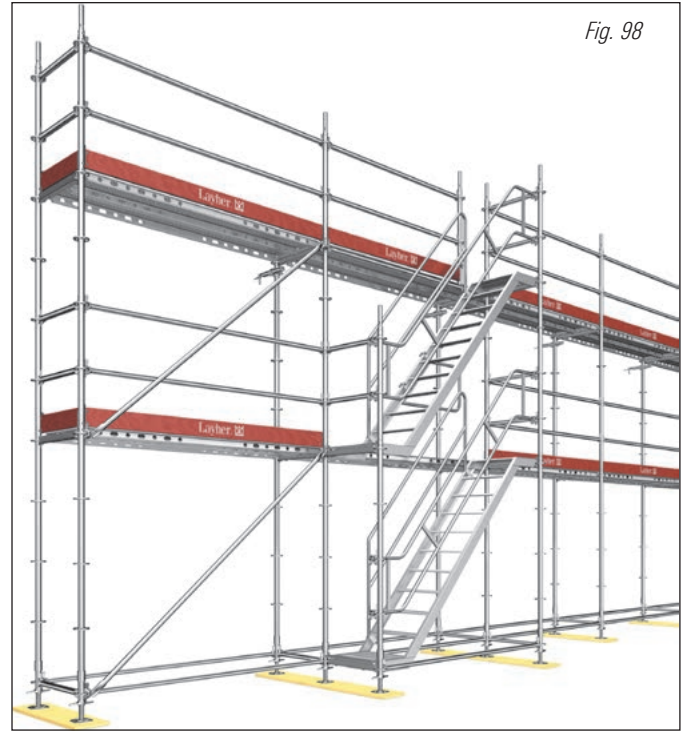

Landing-type stairway tower, free-standing

Check surface for sufficient load-bearing capacity and lay suitable sole plates.

1. Assembly is as for the landing-type stairway access in the façade scaffolding, but with 4 standards.
2. The minimum width of the landing-type stairway tower is 1.40 m.
3. At the exit, fit two stairway guardrail adaptors to the standard at the rosettes.
4. Place the stairway guardrail at the top over the stairway guardrail adaptors and at the bottom over the ledgers, then knock in the wedges.
5. Fit the ledgers as a guardrail and midrail.
6. Fit a support ledger in the middle on the upper longitudinal ledgers.

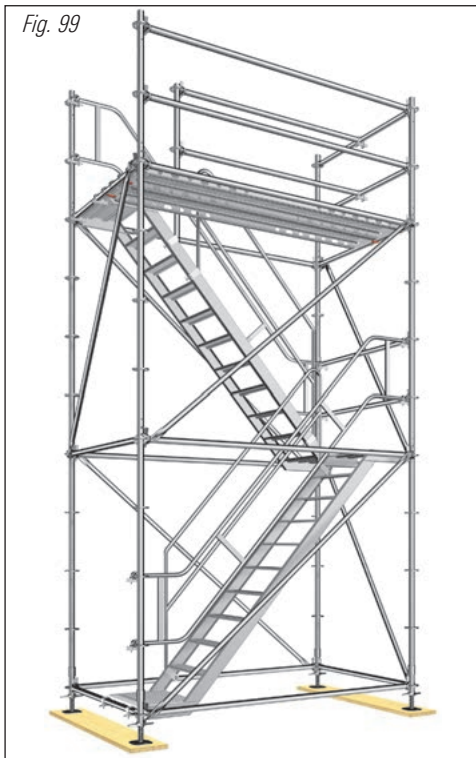

Anchor as necessary in accordance with local regulations. Refer to the section on anchoring.



Internal access – hatch

Internal ladder access with hatches. Arrange hatch openings offset.

Caution: Keep hatches in access deck closed when not in use. This also applies for transporting the access decks. At the bottom level of the access bay, scaffolding decks must be installed as a ladder support surface.



Internal access – support ledgers

1. Fit longitudinal ledgers on the inside and outside of the access bay at the deck level.
2. Install support ledgers transverse to the longitudinal ledgers.

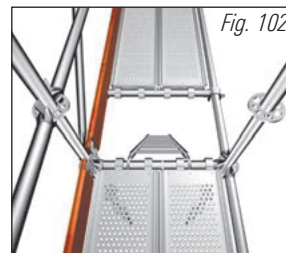

3. Insert steel decks 50 cm shorter than the bay length, and close the lift-off preventer.
4. Attach storey ladder.

Local regulations must be checked as to whether the opening must be closed during working.

External access

1. Fit additional longitudinal ledgers at deck level and 50 cm below deck level.
2. Fit the offset guardrail standard above the aforementioned longitudinal ledger and connect it using ledgers to the vertical standard.
3. Fit the toe board and secure it using a half-coupler with toe board pins to the offset guardrail standard.
4. Fit the swing over gate.
5. Fit the tube on the transom using two swivel couplers.
6. Connect storey ladder to the tube using two standard couplers.



Local regulations must be checked as to whether an external access is possible. If possible, the requirements to handholds and ladder projection must be made according to local regulations. Normally a ladder projection of 1 m is required.

Stairway tower 500

Check surface for sufficient load-bearing capacity and lay suitable sole plates.

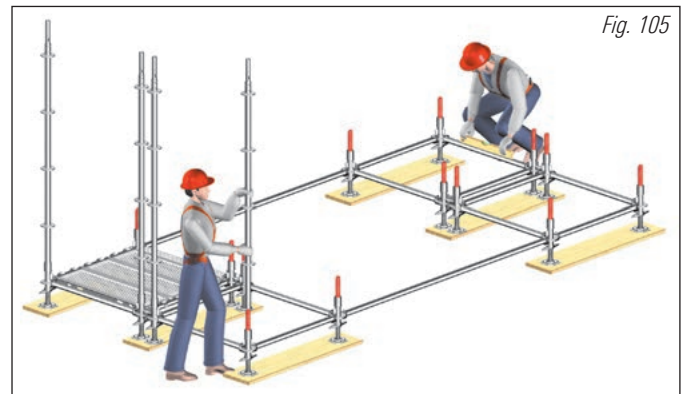
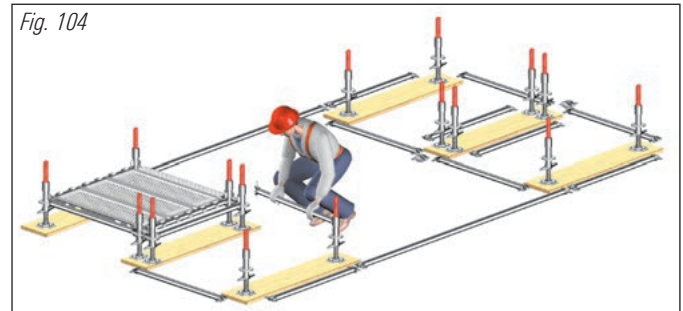

1. Lay longitudinal ledgers and transoms, twin wedge coupler, incl. temporary assembly ledgers of 2.57 m.
2. Place the sole plates at the joints.
3. Position base jacks with attached vertical base collars on the sole plates.
4. Connect ledgers in the small holes of the rosettes, align the base frame of the stairway tower and level using a spirit level.
5. Fit the twin wedge coupler.
6. Lay steel decks in the entry bay, and close the lift-off preventer.
7. Fit vertical standards onto the vertical base collars.

Fig. 106

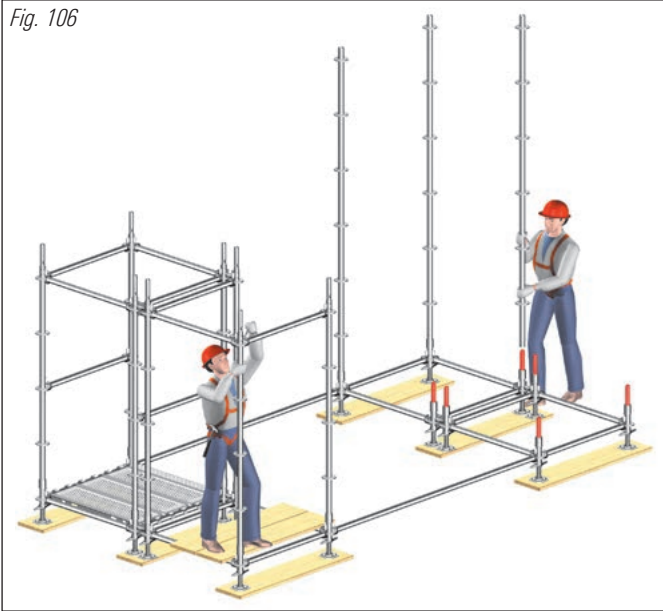

8. Fit ledgers.
9. At the stairway entry and exit fit a ledger with gap cover instead of the normal ledger. (To eliminate trip hazards)
10. Remove the 2.57 m ledgers and fit the stairway stringers.

Fig. 107

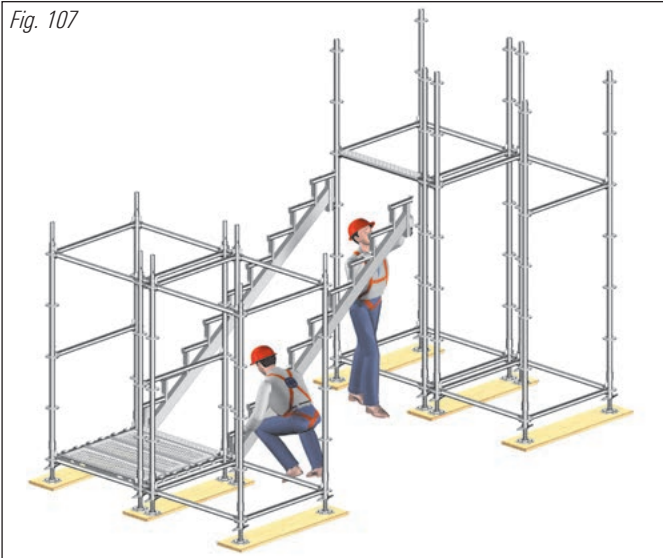
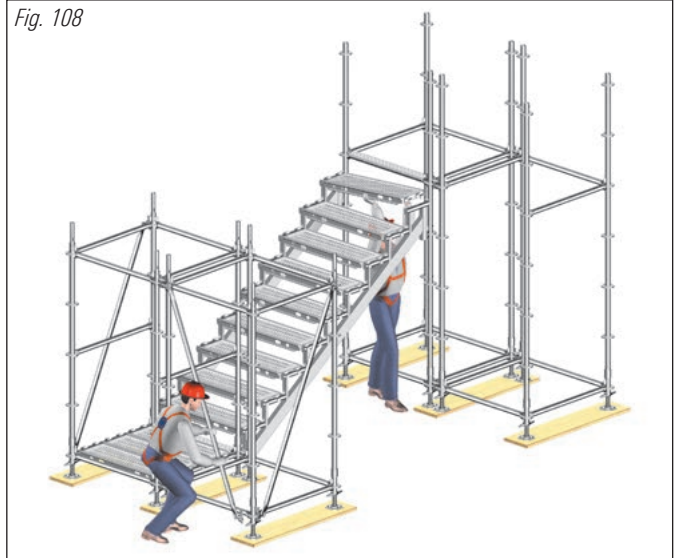

Fig. 108



11. Lay the steel decks, starting from the bottom, on the stringers and ledgers, then close the lift-off preventer. Assembly must take the scaffolding erector's risk assessment into account.
12. Install diagonal braces. Preferably diagonal braces should be installed on the outside of the scaffold.
13. Fit stairway and landing guardrails.

Fig. 109

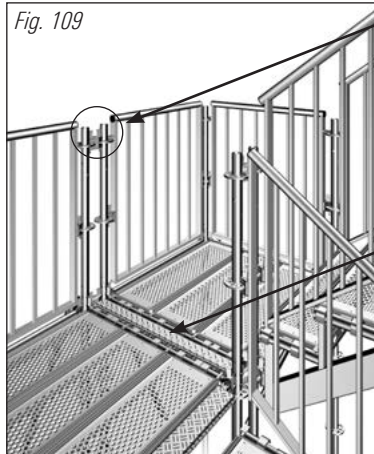

Fig. 110: Twin wedge-head

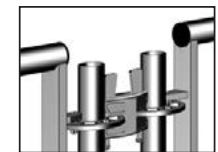

Fig. 111: Gap cover



14. Lay the gap cover on the ledgers and close the lift-off preventer.
15. Fit the twin wedge couplers to the second rosette above the steel decks. Hammer home the wedges.



Fig. 112

16. Repeat the assembly sequence until the required height of the stairway tower is reached.

Anchor as necessary in accordance with strength requirements, refer to the section on anchoring.

14. DECK CUTOUTS AND DECK INSERTS

O-board bearer (steel deck – steel deck)



Fig. 113

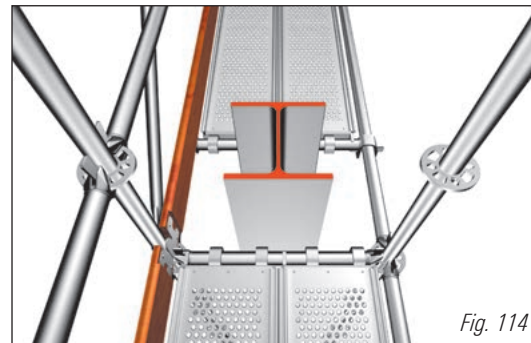

Fig. 114

1. Fit longitudinal ledgers on the inside and outside at the deck level.
2. Lay, position and secure the support ledgers on the two longitudinal ledgers.
3. Lay steel decks of appropriate length on the support ledgers, and close the lift-off preventer.

O-Support ledger (deck to deck)

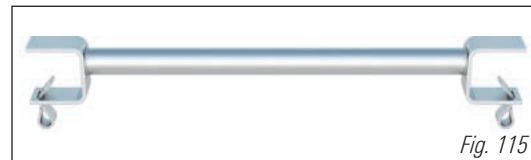

Fig. 115

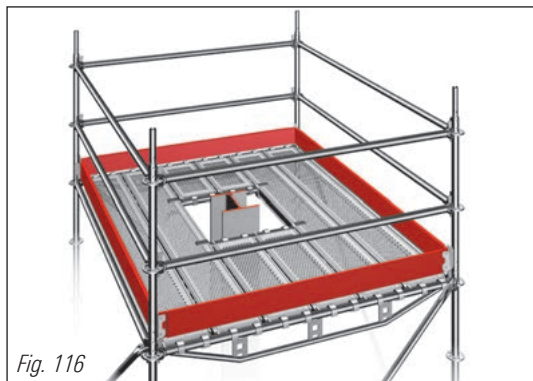

Fig. 116

Recesses and accesses are easily constructed using the O-support ledger

1. Install the appropriate support ledger horizontally at the required points above the steel deck edges.
- 2. Close the locking hook when needed.**
3. Insert the steel decks and prevent them from lifting off.

Steel deck T4

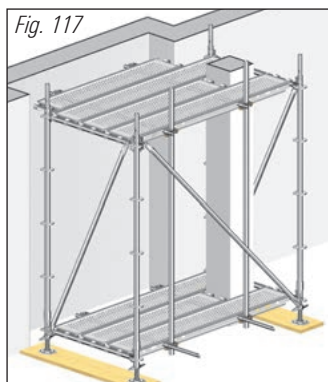

Fig. 117

The holes in the flanges of the T4 steel decks permit insertion of $\varnothing 33.7$ mm steel tubes.

1. Fit the two outer T4 steel decks of the main scaffolding on the transom.
2. Insert the $\varnothing 33.7$ mm steel tube through the openings in the webs of the T4 steel deck.
3. Secure the $\varnothing 33.7$ mm steel tube at the ends with reducing couplers, 48.3 x 33.7 mm.
4. If the niche variant is selected, ensure that the $\varnothing 33.7$ mm steel tube is stiffened on the opposite side with vertical tubes.

15. CORNER SOLUTIONS

Erect the scaffolding starting from the outer corners of the building. Any non-standard (spacing) bays necessary must not be installed in the corner area. The entire scaffolding width must be maintained around the corners.

With 4 vertical standards and short decks.

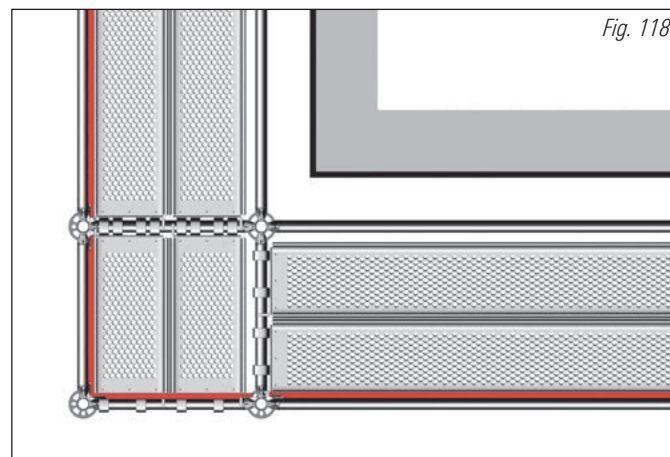

Fig. 118

With 2 vertical standards and longitudinal ledger.

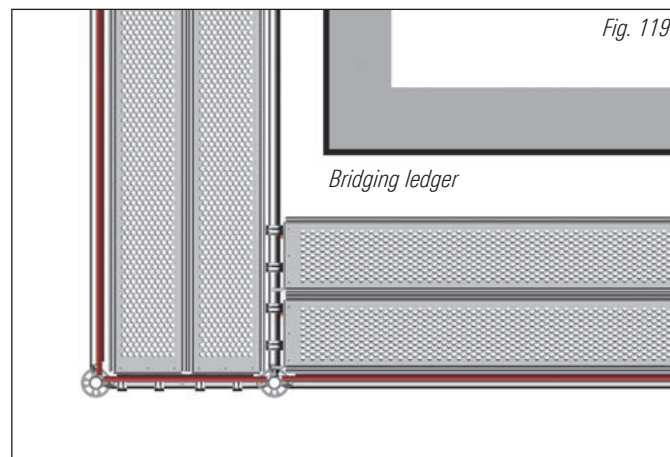

Fig. 119

Bridging ledger

16. BRACKETS AND CANTILEVERS

Close the gap between the bracket and the scaffolding deck in the main bay according to local regulations (e.g. using standard ledger, ledger with gap cover or gap deck). All assembly work on brackets should be performed from the secured lower level.

Bracket 0.39 m

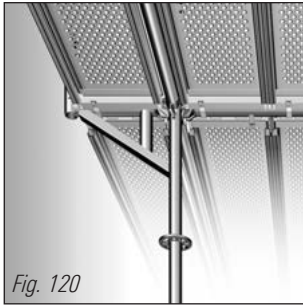

1. Fit 0.39 m bracket to the rosette.
2. Lay steel deck and close the lift-off preventer.

Bracket 0.73 m

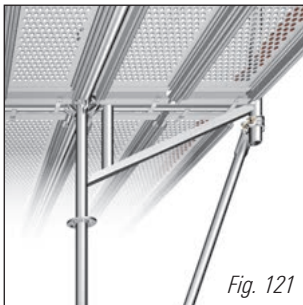

1. Fit 0.73 m bracket to the rosette.
2. Fit the bracket brace.

Tip: Installing a diagonal brace helps increase the load capacity of the bracket.

3. Lay steel decks and close the lift-off preventer.

Bracket 0.69 m, adjustable

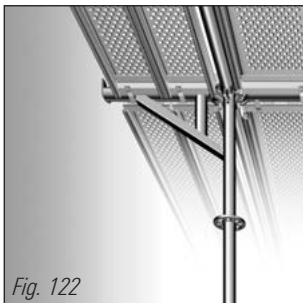

1. Fit 0.69 m adjustable bracket to the rosette.
2. In the non-extended position, lay two steel decks, 0.19 m wide. In the extended position, lay three steel decks, 0.19 m. The maximum loading of the bracket depends on the extension length.

Cantilevered decks using standards, ledgers and diag. braces



1. Fit both ledgers.
2. Connect the vertical standard.
3. Fit the diagonal brace.
4. Lay steel decks and close the lift-off preventer.

Tip: The reason for this variant is to avoid diagonals colliding with decks.

Bracket, 1.09 m



1. Fit 1.09 m birdcage bracket to the rosettes.
2. Lay steel decks and close the lift-off preventer.
3. Connect outer vertical standard to the wedge-head of the 1.09 m birdcage bracket.

Cantilevers



1. Preassemble the bridging ledger, the base collar and the diagonal brace.
2. Connect the preassembled unit with the diagonal head to the upper rosette of the vertical standard.

NOTE

Diagonal braces should be installed on the outside of the scaffold wherever possible. This will assist with the use of horizontal advanced guardrail techniques and make installation of the working platform easier. It also helps to reduce the risk of unintentional dislodging of the wedge.



3. Push the bridging ledger outwards and attach the wedge-head to the rosette of the vertical standard.
4. Repeat the process on the opposite side.

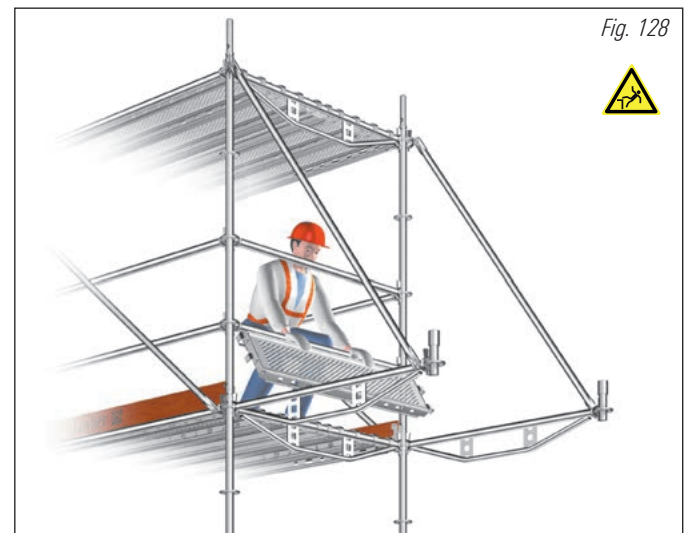

5. Install steel decks from behind guardrails.
6. Push out steel decks along transom to fill cantilevered bay.

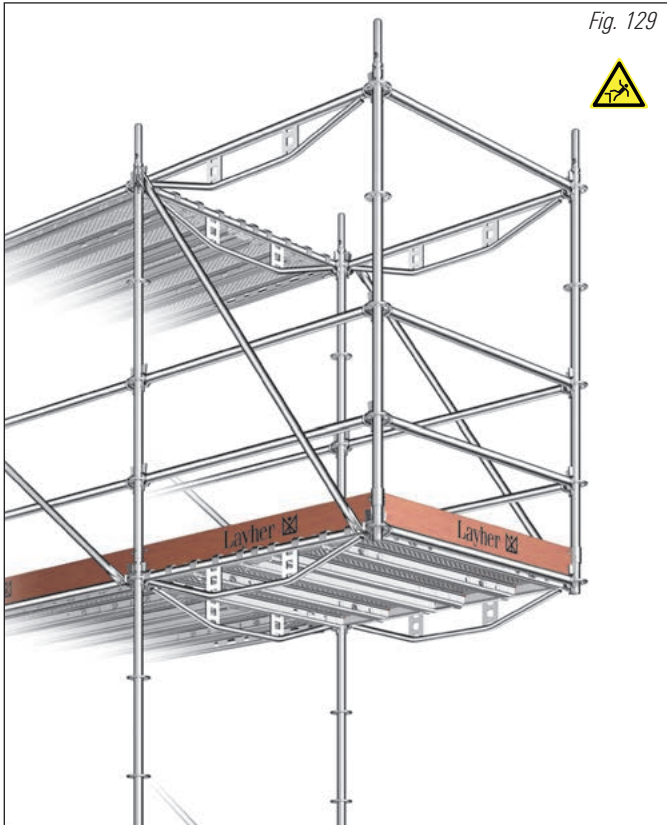

Fig. 129



7. Fit vertical standards onto the base collars.
8. Fit three-piece edge protection, comprising guardrail, midrail, lift-off preventer and toe board. Knock in the wedges.

Verify in each case that the scaffolding structure has sufficient load-bearing capacity.

WARNING

Inadvertently removed wedges of load bearing braces can lead to the collapse of the scaffolding structure and result in serious injury or death.

17. BRIDGING WITH LATTICE BEAMS

Bridging of gate entrances, building projections, balconies or openings is possible using Allround lattice beams (Fig. 130/131) or trusses made using vertical diagonal braces (Fig. 132).

Bridging variant with lattice beam

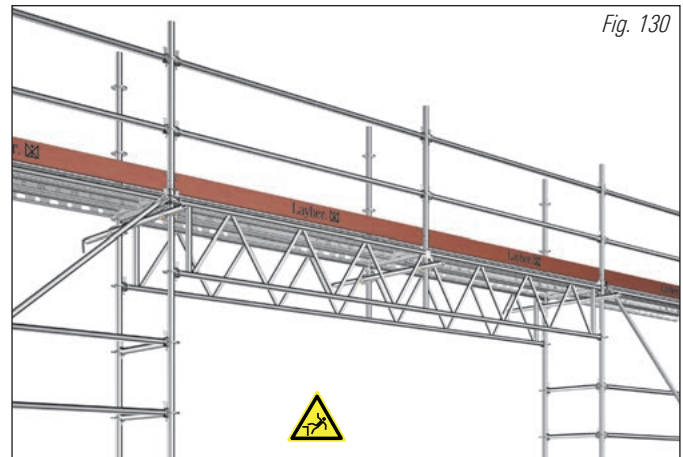

Fig. 130



1. Connect the lattice beam with 4 wedge-heads to the vertical standards from the secured level underneath it.
2. Fit the spigot for the lattice beam at the centre of the latter, using temporary working platforms and assuring they have the correct span.
3. Attach the anchoring of the lattice beam at mid span.
4. Insert the lattice beam ledger using the spigots of the lattice beam.
5. Insert the steel decks, close the lift-off preventer.
6. Place vertical standards onto the spigots for the lattice beam.
7. Fit the three-piece edge protection comprising of a guardrail, midrail and toe board.

Verify in each case, that the bridging structure has a sufficient load-bearing capacity.

Fig. 131

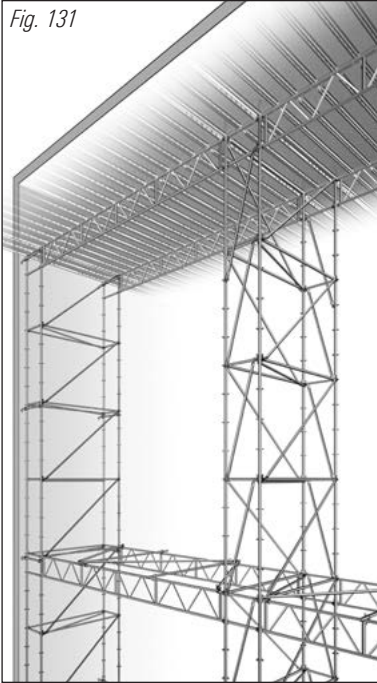

With Allround lattice beams, birdcage scaffolding can be constructed with less material and time.

Bridging variant with truss girders

Fig. 132

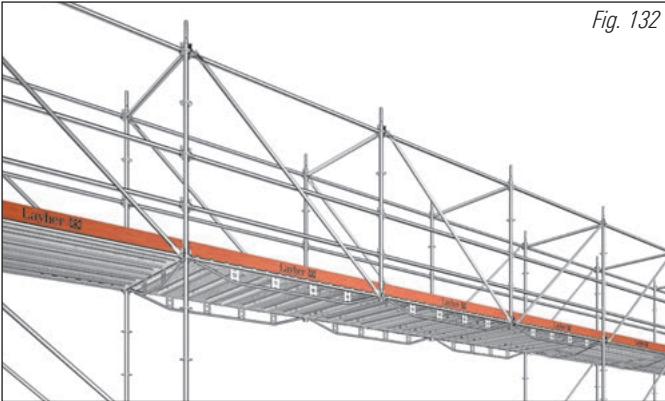

Bridging is also possible in the form of trusses made using vertical diagonal braces. For assembly sequence, see section 16 on brackets and cantilevers.

18. MESH GUARD

The geometrical dimensions of the mesh guard, e.g. width of the scaffolding, clearance from the eaves, must be adapted to local requirements. Scaffold widening using brackets may be necessary.

Caution: At the top level, only decks intended for this application and duly tested may be used!

The façade scaffolding must be constructed as described in section 5. At the top level 4 m standards must be used on the outside. If 2 m standards are used, their joint must be strengthened by an additional tube or standard connected on the outside.

Mesh guard

Fig. 133

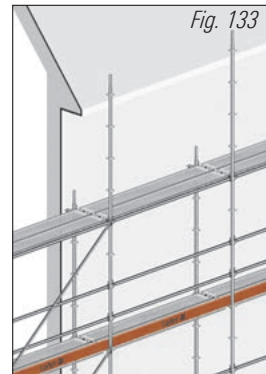

1. To assemble the mesh guard, ledgers are required on the outside at the level of the top deck. These must be fitted from the secured level underneath.
2. Position the lower mesh guard on the ledge, swing it outwards over the rosette as shown, and wedge it tight.
3. Place the upper mesh guard on it and assemble it in the same way.
4. Install the toe board.

Fig. 134



Protection net

The nets must be attached to horizontal ledgers at the bottom (at the working level) and at the top (2 m above the working level). For protection nets, 3 horizontal ledgers 1.0 m apart are required. Only nets designed for this purpose may be used.

1. To fit the protection net, ledgers are required on the outside at the top working level.
2. A toe board and a handrail are required in any event.

For protection nets without quick strap fasteners:

3. In the first step, fit the handrail of the top level.
4. Thread the net into the ledger at the deck level with every mesh. Connect ledger.
5. Thread the net into the top ledger with every mesh. Connect ledger.

For protection nets with quick strap fasteners:

6. The ledger at the deck level can be fitted from the secured level underneath it.
7. Fit handrail of the top level.
8. With quick strap fasteners, the protection net must be attached to the ledgers at every 75 cm. All quick strap fasteners must be firmly closed.

Caution: Protection nets must be checked. If older protection nets are used, it must be verified in tests that the maximum tensile strength of the net yarn is still at least 2 kN.

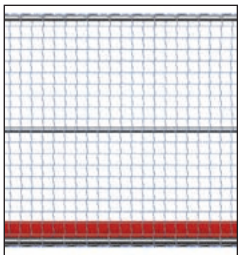

Fig. 135: Without quick strap fasteners

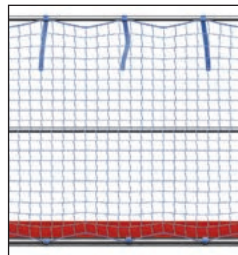

Fig. 136: With quick strap fasteners

19. GROUND ADJUSTMENT

For uneven ground, it is recommended that the scaffolding assembly starts at the highest point of the assembly surface.

The adjustment to ground irregularities and height differences in the ground is achieved using adjustable base jacks.

Caution: The maximum loading of the base jack must not be exceeded when adjusting it, and if necessary it must be stiffened with a tube connected to the base jack by a wedged swivel coupler with spindle insert.

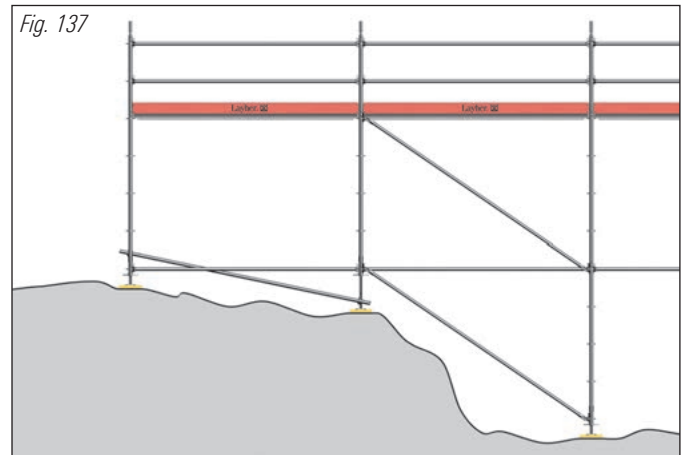

Major height differences can be balanced out by additional vertical standards. Additional standards must be stiffened with diagonal bracing to the base point.

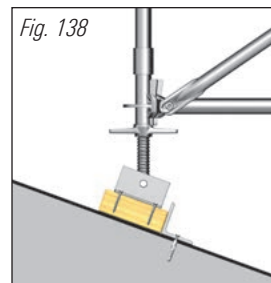

Adjustment for sloping surfaces is achieved by using swivelling base jacks. **Caution:** Here in particular the sole plate and the base jacks must be secured against slipping, and sufficient structural strength of the swivelling base jack must be assured. Base jacks must be in full surface contact with the sole plate.

20. CHANGES IN STANDARD CONFIGURATION

The Allround Scaffolding can be optimally adjusted to site conditions.

Cross sectional tapering of wide scaffolding

Fig. 139



1. Assemble scaffolding as described in section 5, using bridging ledgers in the transverse direction.
2. Fit spigots with half-couplers in the intended configuration dimension on the upper chord of the bridging ledger.

Fig. 140



3. Insert decks and secure them against lifting off.
4. Assemble the next level with the reduced width.

Caution: Check that the bridging ledgers have sufficient load-bearing capacity. The three-piece edge protection comprising guard-rail, midrail and toe board must be installed on all exposed edges of working platforms.

This solution can be applied in similar fashion for birdcage scaffolding and to shorten the bay length.

21. USE OF THE SCAFFOLDING

- After completion of the assembly the scaffold must be inspected and tagged by the scaffolding erector in accordance with section 1 (Inspection and Documentation).
- The scaffolding may only be entered via its accesses; climbing up the scaffolding is prohibited.
- No heavy objects may be thrown onto scaffolding decks, which may only be subjected to the maximum loads listed for the specified load classes.
- Jumping onto scaffolding decks is prohibited.
- No ladders, boxes etc. may be used at the top scaffolding level to increase the working height.
- When storing material or components on working platforms, minimum 20 cm of clear space must be maintained.
- Only decks that are complete may be walked on.
- Hatches in access decks must be closed when not in use.

Additionally applicable for rolling towers

- The wheels of the rolling tower must be locked before it is used.
- No personnel or materials may be on the tower while it is being moved. Movement only by applying manual force to the base.
- The travel path must be level and free of obstructions.

22. DISMANTLING THE SCAFFOLDING

To dismantle scaffolding, the sequence of working steps described for assembly must be reversed. The stability of the scaffolding must be verified prior to dismantling. The following must be noted in addition:

- The scaffolding contractor must ensure that all reasonably foreseeable hazards to health and safety associated with the dismantling are identified before and during dismantling of the scaffolding.
- Any hazard identified must be assessed in terms of risk and must be controlled by the scaffolding contractor.
- Anchoring must not be released until the scaffolding levels above it have been completely dismantled.
- Components of which the connectors have been released must be removed immediately.
- Removed scaffolding components must not be thrown off the scaffolding.
- Scaffolding components must be stored properly.
- Only decking surfaces that are complete may be walked on.
- Scaffolding may only be entered via its accesses.
- Climbing up the scaffolding is prohibited.

WARNING

Risk assessment – Prevent unintended disconnection of load bearing member wedges (e.g. diagonal braces) when knocking out wedges. Inadvertent disconnection of load bearing members reduce the stability of the scaffolding structure and can lead to its collapse.

When using fall-arrest systems don't connect to an attachment point that is part of the structure being dismantled.

NOTE

To avoid unintended dislodging of wedges adjacent to the wedge to be unfastened, it is recommended to put a hand on top of the wedges to be secured from dislodging.

This ensures that even if the wrong wedge is loosened the wedge connection has residual load bearing capacity.



23. BASIC COMPONENTS

Vertical support elements of steel and aluminium

**Standard, steel,
with pressed-in spigot,**
Ref. No. 5603.050, 0.5 m
Ref. No. 2603.xxx, 1.0 – 4.0 m

**Standard, steel,
without spigot,**
Ref. No. 2604.xxx, 0.5 – 4.0 m

**Standard, aluminium,
with pressed-in spigot,**
Ref. No. 3200.xxx, 1.0 – 4.0 m

**Standard, aluminium,
without screw-in spigot,**
Ref. No. 3209.xxx, 1.0 – 4.0 m



Spigot, for 2604.xxx
Ref. No. 2605.000

Spigot, for 3209.xxx
Ref. No. 3209.000

**Lattice beam pin Ø 12 x 65 mm
with safety clip, 2.8 mm,**
Ref. No. 4905.065 / 4905.000

**Special bolt M12 x 60
with nut,** Ref. No. 4905.060

Hinged pin Ø 12 mm,
Ref. No. 4905.666

Locking pin, red
Ref. No. 4000.001

Base collar,
Ref. No. 2602.000

Base collar, extended,
Ref. No. 2660.000



Scaffolding spindles

Base plate 60,
Ref. No. 4001.060, 0.6 m

**Base plate 80,
reinforced,**
Ref. No. 4002.080, 0.8 m

**Swivelling base plate 60,
reinforced,**
Ref. No. 4003.000, 0.6 m

Head jack 60, solid,
Ref. No. 5314.060,
14 – 16 cm fork width

Swivelling head jack 45, solid,
Ref. No. 5312.045,
14 – 16 cm fork width

Cross head jack 45, solid,
Ref. No. 5315.045

**Head part for heavy-duty
support,**
Ref. No. 5312.003

**Base piece for heavy-duty
support,**
Ref. No. 5312.002

**Head jack for heavy-duty
support,**
Ref. No. 5312.004

**Base plate for heavy-duty
support,**
Ref. No. 5312.001

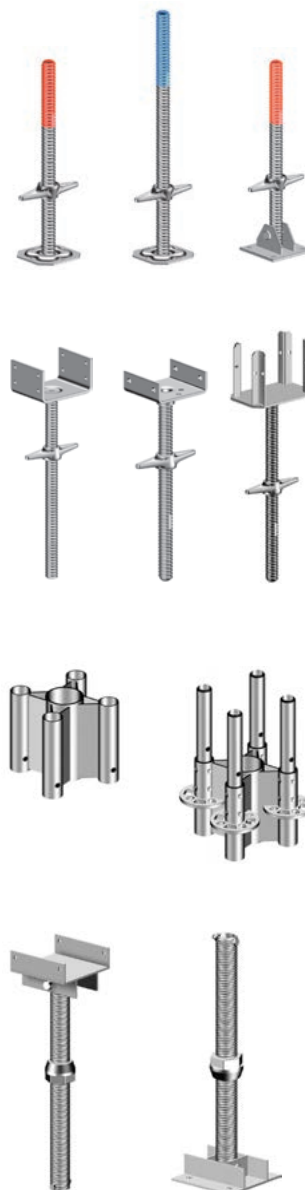

Horizontal support elements, side protection



O-ledge, steel, Ref. No. 2607.xxx, 0.25 – 4.14 m

O-ledge, aluminium, Ref. No. 3201.xxx, 0.73 – 3.07 m



O-ledge, steel, reinforced, Ref. No. 2611.xxx, 1.09 and 1.29 m



U-ledge, steel, Ref. No. 2613.xxx, 0.45, 0.50, 0.73, 1.09 (LW) and 1.40 m (LW)

U-ledge, aluminium, Ref. No. 3203.073, 0.73 m



U-ledge, aluminium, reinforced, Ref. No. 3203.xxx, 1.09 and 1.40 m



U-ledge, steel, reinforced, LW Ref. No. 2613.xxx, 1.57 – 3.07 m



U-bridging ledger, steel, Ref. No. 2624.xxx, 1.57 – 3.07 m

U-bridging ledger, aluminium, Ref. No. 3207.xxx, 1.57 – 2.07 m



O-bridging ledger, steel, Ref. No. 2625.xxx, 1.57 – 3.07 m



U-lift-off preventer

Ref. No. 2635.xxx, 0.39 – 1.57 m

Ref. No. 2658.xxx, 2.07 – 3.07 m



U-ledge steel-deck – steel deck,

Ref. No. 2614.xxx, 0.32, 0.65 and 0.97 m



O-ledge steel-deck – steel deck,

Ref. No. 2614.xxx, 0.32, 0.70 and 1.09 m



O-board bearer, Ref. No. 2615.xxx, 0.73 – 3.07 m



O-toe board, wood, Ref. No. 2642.xxx, 0.73 – 3.07 m

U-toe board, wood, Ref. No. 2640.xxx, 0.73 – 4.14 m

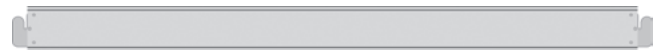

O-toe board, aluminium, Ref. No. 2641.xxx, 0.73 – 3.07 m

U-toe board, aluminium, Ref. No. 2651.xxx, 0.73 – 4.14 m



O-steel toe board, Ref. No. 2648.xxx, 0.73 – 3.07 m

U-steel toe board, Ref. No. 2649.xxx, 0.73 – 3.07 m

Diagonal bracing

Diagonal brace, steel for 2 m bay height, Ref. No. 2620.xxx, 0.73 – 4.14 m

Diagonal brace, steel for 0.5 m, 1.0 m and 1.5 m bay height, Ref. Nos. 2621.xxx, 5606.xxx, 5609.xxx, 5607.xxx, 5610.xxx, 1.57 – 3.07 m

Diagonal brace, aluminium, for 2 m bay height, Ref. No. 3204.xxx, 0.73 – 3.07 m



O-ledger horizontal diagonal, Ref. No. 2608.xxx, 1.57 x 1.57 m – 3.07 x 3.07 m for rectangular floor plans with offset welded wedge-heads. for square floor plans with straight welded wedge-heads.

Scaffolding decks, access decks



U-steel deck, T4, 0.32 m wide, Ref. No. 3812.xxx, 0.73 – 4.14 m



O-steel deck, T9, 0.32 m wide, Ref. No. 3861.xxx, 0.73 – 4.14 m



U-steel deck, 0.19 m wide, Ref. No. 3801.xxx, 1.57 – 3.07 m



O-steel deck, 0.19 m wide, Ref. No. 3848.xxx, 0.73 – 3.07 m



Steel plank, perforated,

Ref. No. 3878.xxx, 0.2 m wide 1.00 – 2.50 m

Ref. No. 3880.xxx, 0.3 m wide 1.00 – 2.50 m available with 1, 2 or without steel bolts



Steel gap cover, perforated,

Ref. No. 3881.xxx, 0.32 m wide 0.73 – 3.07 m



Locking pin

Ref. No. 3800.001



Securing Screw

Ref. No. 3800.004



U-solid wood deck, 0.32 m wide, Ref. No. 3818.xxx, 1.57 – 3.07 m



U-Xtra-N deck, 0.61 m wide, Ref. No. 3866.xxx, 0.73 – 3.07 m



U-robust deck, 0.61 m wide, Ref. No. 3835.xxx, 0.73 – 3.07 m

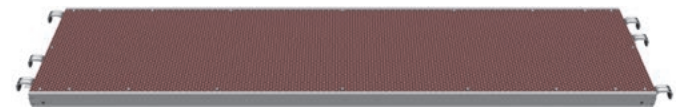

O-robust deck, 0.61 m wide, Ref. No. 3870.xxx, 0.73 – 3.07 m



U-robust deck, 0.32 m wide, Ref. No. 3836.xxx, 1.57 – 3.07 m

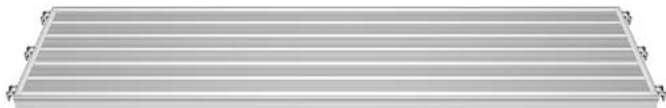

U-Stalu deck, 0.61 m wide, Ref. No. 3850.xxx, 1.57 – 3.07 m



U-Stalu deck, 0.32 m wide, Ref. No. 3856.xxx, 1.57 – 4.14 m



U-aluminium deck, 0.32 m wide, Ref. No. 3803.xxx, 1.57 – 3.07 m

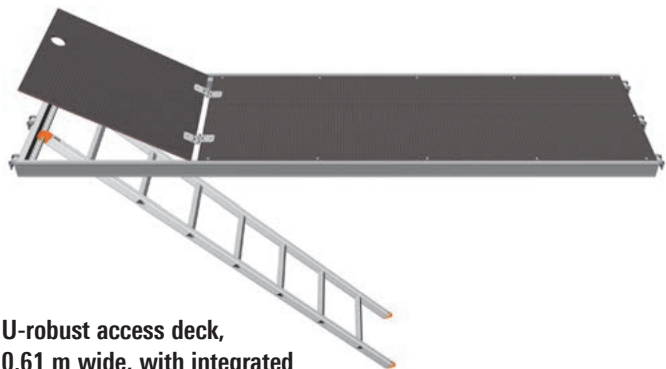

**U-robust access deck,
0.61 m wide, with integrated
access ladder***, Ref. No. 3838.xxx, 2.57 – 3.07 m

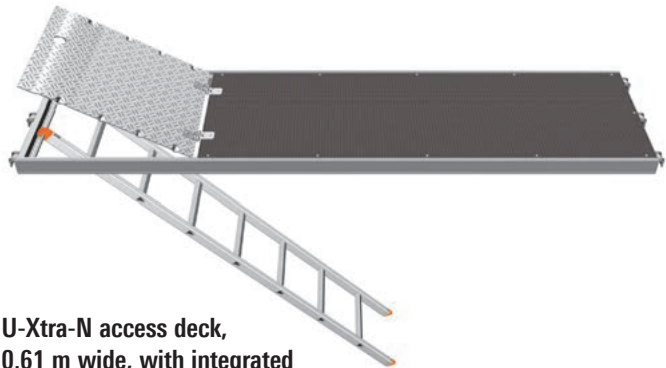

**U-Xtra-N access deck,
0.61 m wide, with integrated
access ladder**, Ref. No. 3869.xxx, 2.57 – 3.07 m

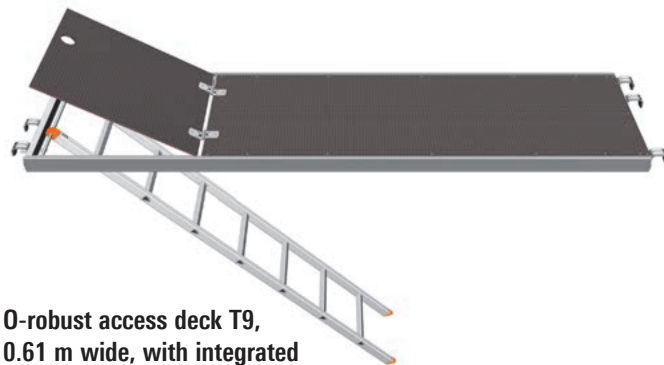

**O-robust access deck T9,
0.61 m wide, with integrated
access ladder***, Ref. No. 3872.xxx, 2.57 – 3.07 m

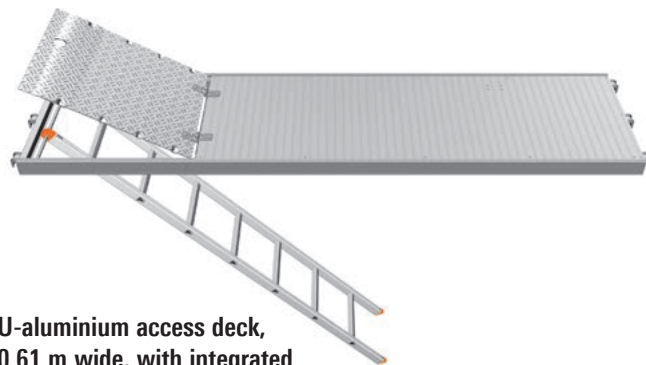

**U-aluminium access deck,
0.61 m wide, with integrated
access ladder***, Ref. No. 3852.xxx, 2.57 – 3.07 m

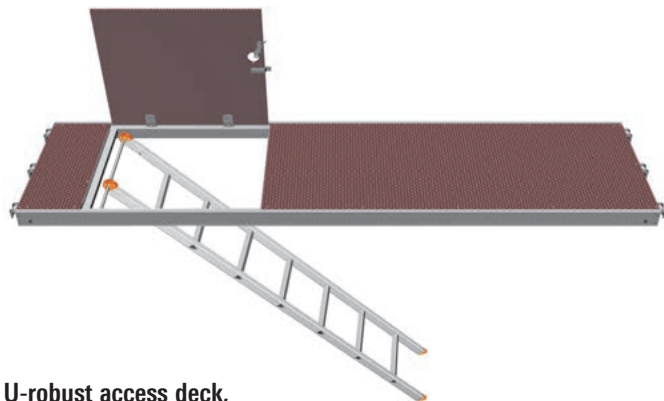

**U-robust access deck,
0.61 m wide, with integrated
access ladder*, hatch offset** Ref. No. 3859.xxx, 2.57 – 3.07 m

** Also available without integrated ladder*

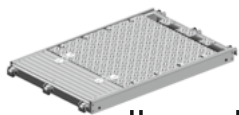

U-access deck, aluminium,
0.61 m wide, 1.00 m long
Ref. No. 3851.100



O-access deck, aluminium,
0,61 m wide, 1.00 m long
Ref. No. 3871.100

Access ladder, 7-rung,
Ref. No. 4005.007, 2.15 m



Brackets

U-console bracket,

Ref. No. 2630.xxx,
0.28 m, 0.39 m and 0.73 m



O-console bracket,

Ref. No. 2631.xxx,
0.26, 0.39 and 0.73 m



O-console bracket, adjustable,

Ref. No. 2630.069,
0.69 m



Bracket brace, Ref. No. 2631.205, 2.05 m



U-console bracket, 1.09 m wide,
Ref. No. 2630.109, 1.09 m



O-console bracket, 1.09 m wide,
Ref. No. 2631.109, 1.09 m

Lattice beams



O-lattice beam with 4 wedge-heads, Ref. No. 2659.xxx, 5.14 – 7.71 m



U-lattice beam with 4 wedge-heads, steel,
Ref. No. 2656.xxx, 3.07 – 6.14 m

U-lattice beam with 4 wedge-heads, aluminium,

Ref. No. 3206.xxx, 1.57 – 5.14 m

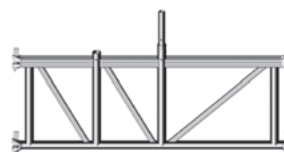

U-walkway beam, 1.57 m wide, Ref. No. 2665.157

U-ledger, for lattice beam,

Ref. No. 4923.xxx,
0.73 and 1.09 m



Spigot for U-lattice beam,

Ref. No. 2656.000

Spigot for O-lattice beam,

Ref. No. 4706.xxx



Mesh guard

Mesh guard

Ref. No. 2663.xxx,
1.57 – 3.07 m



Platform stairway



U-platform stairway, aluminium, Ref. No. 1753.xxx
2.57 m and 3.07 m

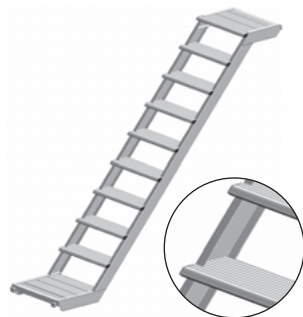

U-comfort stairway, aluminium, Ref. No. 1755.xxx
2.57 m and 3.07 m

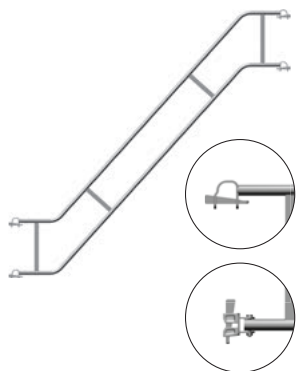

Stairway guardrail, 2.0 m high with U-forks or swivelling wedge-heads;
Ref. No. 2638.xxx, 2.57 – 3,07 m



Internal stairway guardrail T12 2.0 m high
Ref. No. 1752.007/008,
for 2.57 m and 3.07 m stairways



Stairway guardrail adaptor,
Ref. No. 2637.000



Stairwell guardrail
Ref. No. 1752.004/014

Outside access, stairway tower

Pole ladder, aluminium, Ref. No. 1004.xxx,
2.9 m, 4.0 m, 4.9 m and 5.7 m

Pole ladder, steel,
Ref. No. 1002.xxx,
1.5 m, 2.0 m, 3.0 m and 4.0 m



Swing door with aluminium toe board, Ref. No. 2627.xxx,
0.73 and 1.00 m

Spring clip, 11 mm pin,
Ref. No. 1250.000



Guardrail standard, 1.7 m, bent, Ref. No. 2606.170





U-stairway stringer 200, 10-step, 2.0 m storey height

Ref. No. 2638.010, 2.0 x 2.57 m

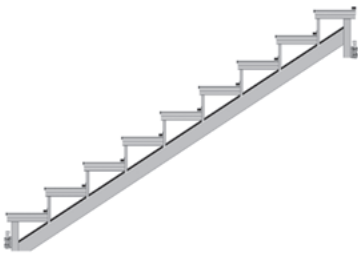

U-stairway stringer 500, 9-step, Ref. No. 2638.009, 2.0 x 2.57 m

U-stairway stringer 500, 5-step, Ref. No. 2638.004, 1.0 x 1.57 m



U-stairway stringer 750, 8-step, Ref. No. 2638.008, 1.5 x 2.57 m

U-stairway stringer 750, 5-step, Ref. No. 2638.005, 1.0 x 1.57 m

**Guardrail for stairs 500,
9-step,**

Ref. No. 2616.100,
2.0 x 2.57 m

**Guardrail for stairs 500,
5-step,**

Ref. No. 2616.104,
1.0 x 1.57 m



**Guardrail for stairs 750,
8-step,** Ref. No. 2616.101,
1.5 x 2.57 m

**Guardrail for stairs 750,
5-step,** Ref. No. 2616.105,
1.0 x 1.57 m

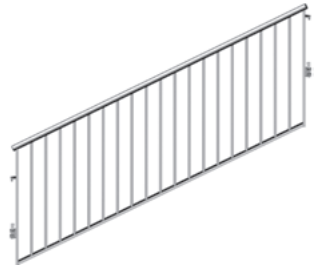

Guardrail with child protection, Ref. No. 2616.xxx,
0.73 – 2.57 m



U-gap ledger,

Ref. No. 2609.xxx,



U-gap deck with wedge-heads,

Ref. No. 2602.xxx
0.73 – 3.07 m



U-gap cover with claws,

Ref. No. 3868.xxx,
1.09 – 2.07 m



Advance guardrail

Advance guardrail post,
for one advance guardrail
(1 m height), aluminium
Ref. No. 4031.001

Advance guardrail post,
for two advance guardrails
(0.5 and 1 m height), aluminium
Ref. No. 4031.002



Advance guardrail,
aluminium,
Ref. No. 4031.207,
1.57 – 2.07 m
Ref. No. 4031.307,
2.57 – 3.07 m



End advance guardrail,
advance guardrail for
end face of scaffolding,
Ref. No. 4031.000



Anchoring

Allround wall tie,
Ref. No. 2639.080,
0.8 m



Couplers



**Wedge-head
coupler, rigid,**
Ref. No. 2628.xxx



**Wedge-head
coupler, swivel-
ling,**
Ref. No. 2629.xxx



Twin wedge-head,
Ref. No. 2628.000

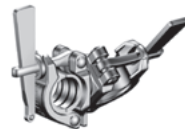

**Wedge swivel coupler with
spindle insert,**
Ref. No. 4735.000



Clampable rosette,
Ref. No. 2602.019/022



**Clampable rosette
with thread**
Ref. No. 2602.119/122





Layher® 

More Possibilities. The Scaffolding System.

Wilhelm Layher GmbH & Co. KG
Scaffolding Grandstands Ladders

Ochsenbacher Strasse 56
74363 Gueglingen-Eibensbach
Germany

P.O. Box 40
74361 Gueglingen-Eibensbach
Germany
Telephone +49 (0) 71 35 70-0
Telefax +49 (0) 71 35 70-265
E-Mail info@layher.com
www.layher.com

