



University of Idaho

College of Engineering

**Mechanical Engineering Department
ME 410 Principles of Lean Manufacturing, 2017**

Title

Lean Manufacturing Mentor Guide

For Manual Lathes and Manual Mills

Students

original draft by Mostafa Asfoor and Drew Flerchinger

updated Feb. 6, 2014 & June 2, 2017

Lean Manufacturing Mentor Guide

Contents

Project Description	
Shop Orientation/Safety	
General Lathe Tips	
Lathe Operations	
Lath Project Manufacturing Plan	
General Mill Tips	
Lathe Operations	
Mill Project Manufacturing Plan	
General CNC Machining Tips	
General Welding Tips	
Appendix Mill/ Lathe/ Drill Cutting Speeds, Feed Rate Chart	

Lean Manufacturing Mentor Guide

Project Description

This project was proposed as a kaizen project for Lean Manufacturing. Before its completion, there was no organized introduction to mentoring for Lean Manufacturing. This was especially problematic for students that had never taken the class before mentoring it. To remedy this situation, a binder has been made that outlines the steps of the block project that the students complete over the first two weeks of the class. The purpose of this project is to provide a forum for mentors to stay one day ahead of the students for machining the block as well as offer methods and tips for conducting the machining processes to help the mentor answer questions the students may have and make sure everything is done correctly.

In its present state, this binder includes thorough manufacturing plans for making each part on the manual mill and lathe. After each machine's manufacturing plan is a section of notes regarding correct procedure for each process required to make the block from. Notes for giving shop orientation on the manual mills and lathes are also included as a quick reference for mentors.

As this is a kaizen project, it is not complete, but rather should be added to in the future. In order to encourage this, the table of contents does not include page numbers for each section, but rather the sections are separated by tabs. In fact, there are tabs for CNC Machining as well as welding even though in the present state nothing has been included for either section. The authors of this project have limited to no experience in either section, so it is suggested that future work for this project includes someone with experience in these topics adding notes to this section.

Lean Manufacturing Mentor Guide

Shop Orientation/Safety

The first day of Lean Manufacturing is a shop orientation for the students. This is required for them to be shop certified so that they can work in the shop under a mentor's guidance. The shop orientation checklist can be found on the Machine Shop website. As a mentor, it is advised to read through the document prior to giving an orientation so that you can be prepared to answer any questions and have a plan for what to talk about in each section. Included below are notes to help with the manual lathe and mill:

Manual Lathe

___ Changing jaws in 3-jaw chuck

___ Changing to collet chuck on lathe #1

___ Changing from 3-jaw to 4-jaw chuck

___ Using a live center.

Use for long parts to prevent deflection (a part in the lathe is a cantilever beam)

___ Tools and tool holders (Kept in drawers)

Cuts are made from diameter NOT radius

___ Setting tool heights

___ Which tools to use

Boring bar, reamer, drill, countersink, etc.

___ Carbide Vs. high speed

Carbide is used for harder materials such as steel while high speed is used for softer materials such as aluminum

___ Changing from high range to low range

Change only when the machine is NOT running

___ Speed control (Change **ONLY** when lathe is running).

Reference charts to pick correct speed

___ Lead screw (engage only when lathe is **NOT** running).

___ Speeds and feeds, power feeds (longitudinal and traverse)

___ Z travel indicator

Lean Manufacturing Mentor Guide

- ___ Setting and adjusting the compound rest
- ___ No long parts protruding out of headstock unsupported
- ___ Carriage Lock

Lean Manufacturing Mentor Guide

Again, parts in the lathe are a cantilever beam; the shorter the part the smaller the moment

Manual Mill:

- ___ D.R.O's (digital read only)
 - Show how to zero, can be used for extremely precise mill operations*
- ___ Speed change (belts and high/low)
 - DO NOT adjust when motor is not running. Low speed runs in reverse. See cutting speed charts for speed to use –reaming tools run at half of the speed shown on the chart*
- ___ Vise, hold down clamps, parallels, lead hammers, and indicators
 - Located in cabinet next to Russ's office. Use hammers to get parts flat in vise and parallels for cuts above vise jaws. Clamps used for weird geometry parts that the vise can't hold down well enough.*
- ___ Do not leave vise sitting on mill and not bolted down
- ___ Tram, tilt head
- ___ Clamps
- ___ Edge finders
 - Make sure to account for .2 dia. (move .1 further after zeroing, zero again)*
- ___ Filing, deburring parts
 - Metal is sharp when cut, make sure to file/debur when cut is finished*
- ___ Finishes
 - Climb cut for smooth finish*
- ___ Power feeds (x,y,z)
- ___ Do not leave power feed speed-control dials turned up when finished with mill for the day
 - This could mess up somebody else's part.*

Lean Manufacturing Mentor Guide

___ Boring head

In the grey cabinet next to mill 1.

___ Right angle head

Not really used, but in the cabinets by scrap metal if a student asks. Used for long parts that can't fit under mill.

___ Spindle key for collets, drill chucks, etc.

___ Keep chips swept back to avoid tracking throughout the shop

General Lathe Tips

- Always double check to make sure your work is securely clamped in the chuck or between centers before starting the lathe. Start the lathe at low speed and increase the speed gradually.
- Get in the habit of removing the chuck key immediately after use. Some users recommend never removing your hand from the chuck key when it is in the chuck. The chuck key can be a lethal projectile if the lathe is started with the chuck key in the chuck.
- Keep your fingers clear of the rotating work and cutting tools. This sounds obvious, but don't try breaking away metal spirals as they form at the cutting tool.
- You must consider the rotational speed of the workpiece and the movement of the tool relative to the workpiece. Basically, the softer the metal the faster the cutting.
- One of the great features of the lathe is that you can adjust the rotational speed without stopping to change gears. Most cutting operations will be done with the HI/LO gear in the LO range. Higher speeds, and particularly the HI range, are used for operations such as polishing, and cutting aluminum and brass.
- To gain a good understanding of the lathe, you will need to know the names of the various components, as illustrated below. The carriage, in the circled area, consists of the apron, the vertical casting on which the carriage hand wheel is mounted, and the saddle (not shown), the H-shaped casting that rides on the ways to which the apron is attached.

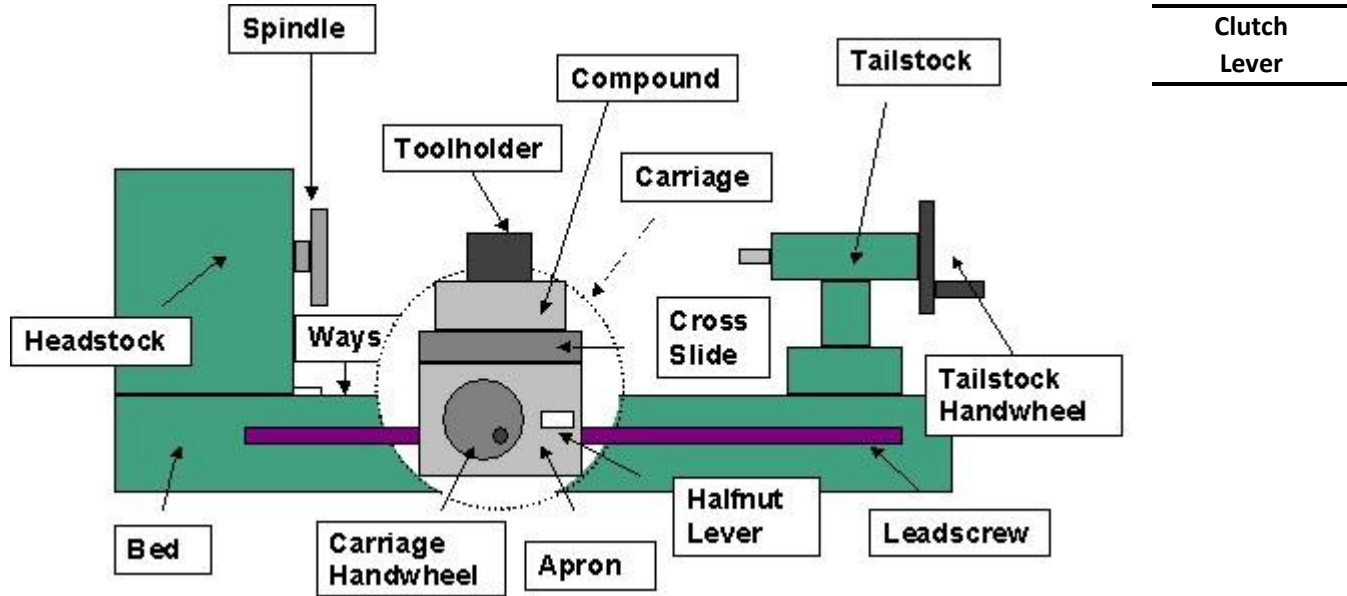

Glossary of Lathe Terms

Apron	Front part of the carriage assembly on which the carriage hand-wheel is mounted
Bed	Main supporting casting running the length of the lathe
Between Centers	<ol style="list-style-type: none"> 1. A method of holding a workpiece by mounting it between a center in the headstock spindle and a center in the tailstock spindle (see Center). 2. A dimension representing the maximum length of a workpiece that can be turned between centers.
Carriage	Assembly that moves the Toolpost and cutting tool along the ways
Carriage Handwheel	A wheel with a handle used to move the carriage by hand by means of a rack and pinion drive
Carriage Lock	A mechanism for locking the carriage to the ways so that the saddle does not move along the ways during facing operations.
Center	A precision ground tapered cylinder with a 60° pointed tip and a Morse Taper shaft. Used in the tailstock to support the end of a long workpiece. May also be used in the headstock spindle to support work between centers at both ends. Also the process of positioning a workpiece accurately in line with a drill or mill.

Lean Manufacturing Mentor Guide

Center Drill	<ol style="list-style-type: none"> 1. A short, stubby drill used to form a pilot hole for drilling and a shallow countersunk hole for mounting the end of a workpiece on a center. 2. The process of drilling a workpiece with a center drill
Clutch Lever	Lever to engage the carriage with the leadscrew to move the carriage under power
Chuck	A clamping device for holding work in the lathe or for holding drills in the tailstock.
Compound	Movable platform on which the Toolpost is mounted; can be set at an angle to the workpiece. Also known as the compound slide and compound rest.
Compound Handwheel	A wheel with a handle used to move the compound slide in and out. Also known as the compound feed.
Countersink	<ol style="list-style-type: none"> 1. To form a shallow, cone-shaped hole surrounding a smaller diameter drilled hole. A countersink is often used so that the head of a flat-head screw will be flush with, or slightly below, the surface in which the screw is being used. 2. A cutting tool, similar to a drill bit, with a cone-shaped tip, used to cut a countersink hole. Often combined with a short drill bit tip as a "combination drill and countersink", or center drill.
Cross Feedthe	A hand-wheel or crank that moves the cross-slide by turning a screw. Also the action of moving cross slide using the cross feed hand-wheel.
Cross Slide	Platform that moves perpendicular to the lathe axis under control of the cross-slide hand-wheel
Cross-slide Handwheel	A wheel with a handle used to move the cross-slide in and out. Also known as the cross feed.
Cutting Tool	The tool that does the cutting, or removal of metal or other material. May refer to any type of cutting tool such as a drill, reamer or a lathe bit. A lathe bit typically has a square cross-section with a sharpened tip on one end. It is made from very hard and heat-resistant material such as High Speed Steel or a form of carbide.

Faceplate	A metal plate with a flat face that is mounted on the lathe spindle to hold irregularly shaped work.
Handwheel	A wheel turned by hand to move a component of a lathe or other machine tool. Often will have a handle extending from the front face. The handle facilitates rapid turning of the hand-wheel.
Headstock	The main casting mounted on the left end of the bed, in which the spindle is mounted. Houses the spindle speed change gears.
Leadscrew	Precision screw that runs the length of the bed. Used to drive the carriage under power for turning and thread cutting operations. Smaller leadscrews are used within the cross-slide and compound to move those parts by precise amounts.
Pilot Hole pilot	A shallow hole, usually cone-shaped, drilled as a starter hole before drilling a deeper hole. The hole helps to ensure that the drill bit enters the material at the desired location and does not drift as the bit starts cutting into the material being drilled.
Saddle	A casting, shaped like an "H" when viewed from above, which rides along the ways. Along with the apron, it is one of the two main components that make up the carriage.
Spindle	Main rotating shaft on which the chuck or other work holding device is mounted. It is mounted in precision bearings and passes through the headstock.
Spindle Throughhole	A dimension indicating the minimum diameter of the hole that passes through the spindle. A workpiece with a diameter smaller than this can pass through the spindle to facilitate working on long pieces of work.
Swing	A dimension representing the largest diameter workpiece that a lathe can rotate. A related dimension, Swing Over Carriage or Swing Over Cross Slide, is the maximum diameter workpiece that can rotate over the cross slide.
Tailstock	Cast iron assembly that can slide along the ways and be locked in place. Used to hold long work in place or to mount a drill chuck for drilling into the end of the work.
Tailstock Handwheel	A wheel with a handle used to move the tailstock ram in and out of the tailstock casting.
Tailstock Ram	A piston-type shaft that can be moved in and out of the tailstock by turning the tailstock handwheel. Has a tapered internal bore to accept a Morse Taper shank. The shaft, or ram, is advanced or withdrawn by rotating the tailstock hand-wheel located on the right end of the tailstock. The ram can be locked in place at a specific point by a locking lever.
Tool	A cutting tool used to remove metal from a workpiece; usually made of High Speed Steel or carbide.
Toolpost	A holding device mounted on the compound into which the cutting tool is clamped
Ways	Precision ground surfaces along the top of the bed on which the saddle rides. The ways are precisely aligned with the centerline of the lathe.

Lean Manufacturing Mentor Guide

Lathe Operations

- Operations that could be done on the Lathe

- Facing - Turning - Drilling - Parting - Boring- Tapping & Threading

- **Facing**

- Facing is the process of removing metal from the end of a workpiece to produce a flat surface. Most often, the workpiece is cylindrical, but using a 4-jaw chuck you can face rectangular or odd-shaped workpiece to form cubes and other non-cylindrical shapes.
- To safely perform a facing operation the end of the workpiece must be positioned close to the jaws of the chuck because when a lathe cutting tool removes metal it applies considerable tangential (i.e. lateral or sideways) force to the workpiece.
- The workpiece should not extend more than 2-3 times its diameter from the chuck jaws unless a steady rest is used to support the free end.

- Preparing for the Facing Cut

- Clamp the workpiece tightly in the 3-jaw chuck. To get the work properly centered, close the jaws until they touch the surface of the workpiece then use a dial indicator to adjust center line of the workpiece, and then tighten the jaws.

- Choose a cutting tool with a slightly rounded tip. A tool with a sharp pointed tip will cut little grooves across the face of the workpiece and prevent you from getting a nice smooth surface. Clamp the cutting tool in the tool post and turn the toolpost so that the tip of the cutting tool will meet the end of the workpiece at a slight angle. It is important that the tip of the cutting tool be right at the centerline of the lathe; if it is too high or too low you will be left with a little bump at the center of the face.

- Clamp the Toolpost in place and advance the carriage until the tool is about even with the end of the workpiece. Make sure that the compound is not all the way at the end of its travel towards the chuck; about midway in its range of travel is good.

- Beginning the Facing Cut

- Use the compound hand-wheel to advance the tip of the tool until it just touches the end of the workpiece. Use the cross feed crank to back off the tool until it is beyond the diameter of the workpiece. Turn the lathe on and adjust the speed to the proper RPM. Now slowly advance the cross feed hand-wheel to move the tool towards the workpiece. When the tool touches the workpiece it

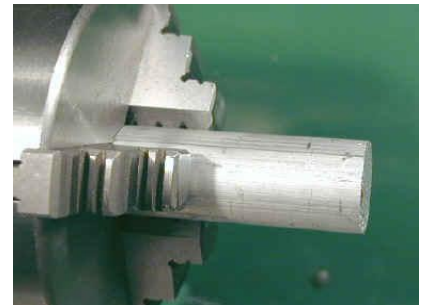

Lean Manufacturing Mentor Guide

should start to remove metal from the end. Continue advancing the tool until it reaches the center of the workpiece and then crank the tool back in the opposite direction (towards you) until it is back past the edge of the workpiece.

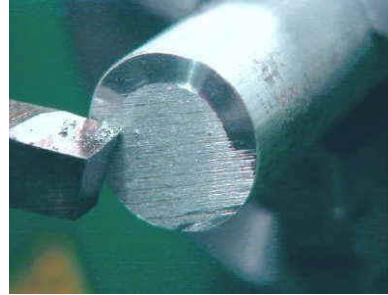
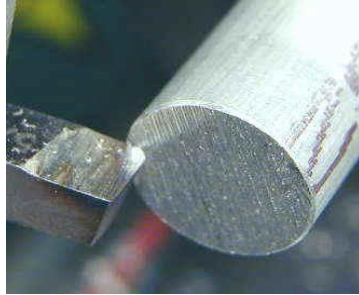

- We started with the tool just touching the end of the workpiece; so we probably removed very little metal on this pass. This is a good idea until we get used to how aggressively you can remove metal without stalling the lathe. Also, since the end of the workpiece can be very uneven, we want to avoid gouging the tool into the end of the workpiece if it hits a high spot.

□ The Roughing Cut

- With the tool just touching the end of the workpiece, move the dial indicator into position and lock at 0. Use the dial indicator to monitor the length of the cuts. Tighten the carriage clamp to prevent the carriage from being pushed away from the end of part while facing.



□ Cutting on the Return Pass

- If you crank the tool back towards you after it reaches the center of the workpiece you will notice that it removes a small amount of material. You should move away from the part after the finish pass in order to maintain a smooth finish.



Lean Manufacturing Mentor Guide

□ The Finishing Cut

- Depending on how rough the end of the workpiece was to begin with and how large the diameter is, you may need to make 3 or more passes to get a nice smooth finish across the face. These initial passes are called roughing passes and remove a relatively large amount of metal.
- When you get the face pretty smooth you can make a final finishing cut to remove just .001 to .003" of metal and get a nice smooth surface. The finishing cut can also be made at higher RPM to get a smoother finish.
- If the tip of your cutting tool is below the center line of the lathe, a little nub is left at the center of the workpiece. The same thing happens if the tool is too high but the nub will have more of a cone shape in that case. If the tool is too low, place a suitable thickness of shim stock underneath the tool in the tool holder. If it's too high, grind the top down.

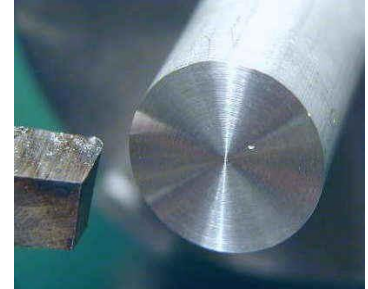

□ Filing the Edge

- Facing operations leave a rather sharp edge on the end of the workpiece. It's a good idea to smooth this edge down with a file to give it a nice chamfer and to avoid cutting yourself on it. With the lathe running at fairly low speed, bring a smooth cut file up to the end of the workpiece at a 45 degree angle and apply a little pressure to the file.



Wrong: left hand reaching over spinning chuck!



Right - left hand holding tang end of file

This is what a good facing cut should look like: smooth even surface with no raised bump in the center. Lay an accurate straight edge across the surface of the face and you should not be able to see any light under the edge. If you detect a slight convex shape, the carriage may be moving back away from the headstock during the cut.

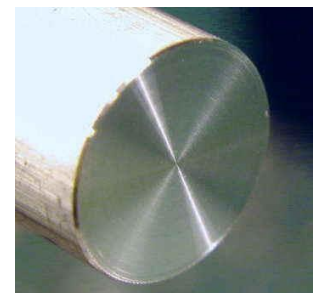

Lean Manufacturing Mentor Guide

□ Turning

□ Turning is the removal of metal from the outer diameter of a rotating cylindrical workpiece. Turning is used to reduce the diameter of the workpiece, usually to a specified dimension, and to produce a smooth finish on the metal.

□ Chucking the Workpiece

- We will be working with a piece of 6061 aluminum not too long. A workpiece such as this which is relatively short compared to its diameter is stiff enough that we can safely turn it in the three jaw chuck without supporting the free end of the workpiece.
- For longer workpieces we would need to face and center drill the free end and use a dead or live center in the tailstock to support it. Without such support, the force of the tool on the workpiece would cause it to bend away from the tool, producing a strangely shaped result. There is also the potential that the work could be forced to loosen in the chuck jaws and fly out as a dangerous projectile.
- Insert the workpiece in the 3-jaw chuck and tighten down the jaws until they just start to grip the workpiece. Rotate the workpiece to ensure that it is seated evenly and to dislodge any chips or grit on the surface that might keep it from seating evenly. You want the workpiece to be as parallel as possible with the center line of the lathe, though use a dial indicator. Tighten the chuck using each of the three chuck key positions to ensure a tight and even grip.



□ Adjusting the Tool Bit

- Choose a tool bit with a slightly rounded tip. This type of tool should produce a nice smooth finish. For more aggressive cutting, if you need to remove a lot of metal, you might choose a tool with a sharper tip. Make sure that the tool is tightly clamped in the toolholder.
- Adjust the angle of the toolholder so that the tool is approximately perpendicular to the side of the workpiece. Because the front edge of the tool is ground at an angle, the left side of the tip should engage the workpiece, but not the entire front edge of the tool. The angle of the compound is not critical; I usually keep mine at 90 degrees so that the compound dial advances the work .001" per division towards the chuck.
- Make sure that the carriage lock is not tightened down. If necessary, back off the cross slide until the tip of the tool is back beyond the diameter of the workpiece. Move the carriage until the tip of the tool is near the free end of the workpiece, then advance the cross slide until the tip of the tool just touches the side of the workpiece. Move the carriage to the right until the tip of the tool is just beyond the free end of the workpiece.

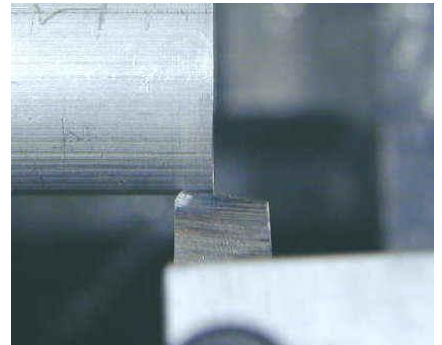

□ Cutting Speeds

- For roughing, the feed range should be approx. .005 - .008 Inches per revolution, and approx. .002 - .003 inches per revolution for finishing.

Lean Manufacturing Mentor Guide

- Until you get a feel for the proper speeds, start with relatively low speeds and work up to faster speeds. One of the great features of the lathe is that you can adjust the rotational speed without stopping to change gears. Most cutting operations will be done at speeds of a few hundred RPM with the HI/LO gear in the LO range. Higher speeds, and particularly the HI range, are used for operations such as polishing as well as machining aluminum, brass, and plastics.

□ Turning with Hand Feed

- As always, wear safety glasses and keep your face well away from the work since this operation will throw off hot chips and/or sharp spirals of metal.
- Now advance the cross slide crank about 10 divisions or .010" (one one-hundredth of an inch). Turn the carriage handwheel counterclockwise to slowly move the carriage towards the headstock. As the tool starts to cut into the metal, maintain a steady cranking motion to get a nice even cut. It's difficult to get a smooth and even cut turning by hand.
- Continue advancing the tool towards the headstock until it is about 1/4" away from the chuck jaws. Obviously you want to be careful not to let the tool touch the chuck jaws!
- Without moving the cross slide or compound, rotate the carriage handwheel clockwise to move the tool back towards the free end of the work. You will notice that the tool removes a small amount of metal on the return pass. Advance the cross slide another .010 and repeats this procedure until you have a good feel for it. Try advancing the cross slide by .020 on one pass. You will feel that it takes more force on the carriage hand wheel when you take a deeper cut.

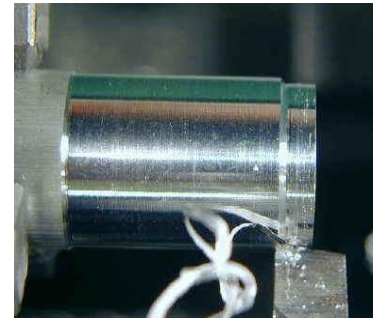
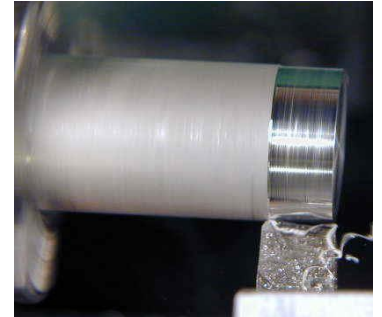

□ Turning with Power Feed

- One of the great features of the lathe is that it has a power leadscrew driven by an adjustable gear train. The leadscrew can be engaged to move the carriage under power for turning and threading operations. Turning with power feed will produce a much smoother and more even finish than is generally achievable by hand feeding. Power feed is also a lot more convenient than hand cranking when you are making multiple passes along a relatively long workpiece.
- The lead screw is engaged by a gear lever on the headstock.
Never do this when the lathe is running. To change the lever setting you must pull back on the sleeve with considerable force. With the sleeve pulled back you can move the lever up and down to engage its locking pin in one of three positions. In the center position the leadscrew is not engaged and does not turn. In the upper position the leadscrew rotates to move the carriage towards the headstock and in the lower position the leadscrew moves the



Lean Manufacturing Mentor Guide

carriage away from the headstock. For turning, you will generally want to cut towards the headstock, so move the lever to the upper position and release the sleeve to engage the locking pin.

- In the down position, the clutch lever engages the leadscrew. Make sure the clutch lever is in the disengaged (up) position. Turn the motor on. The leadscrew should now be rotating counterclockwise. When the leadscrew is engaged the gear train makes kind of an annoying noise, but you'll get used to it.
- With the tool positioned just beyond the end of the workpiece and advanced to make a cut of .010, engage the clutch lever. The carriage should move slowly to the left under power from the leadscrew. When the tool gets to within about 1/4" of the chuck, disengage the clutch lever to stop the carriage motion.
- Now you can use the carriage handwheel to crank the carriage back to the starting point by hand. If you do so without first retracting the cutting tool, you will see that the tool cuts a shallow spiral groove along the workpiece. To avoid this, especially during finishing cuts, note the setting on the cross-slide dial, and then turn the cross feed crank a half turn or so counterclockwise to retract the tool. Now crank the carriage back to the starting point by hand, advance the cross-slide back to the original dial setting plus an additional .010 and repeat the process. You should get a nice, shiny, smooth finish.
- Just as in facing, you normally will make one or more relatively deep (.010-.050) roughing cuts followed by one or more shallow (.001-.002) finishing cuts. Of course you have to plan these cuts so that the final finishing cut brings the workpiece to exactly the desired diameter.
- When cutting under power, you must be very careful not to run the tool into the chuck. This seems to happen to everyone at one time or another, but it can shatter the tool and damage the chuck and will probably ruin the workpiece. There is also potential to damage the clutch, leadscrew or other parts of the power train, so pay close attention and keep your hand ready on the half nut lever.



□ Measuring the Diameter

- Most of time, a turning operation is used to reduce the workpiece to a specified diameter. It is important to recognize that, in a turning operation, each cutting pass removes twice the amount of metal indicated by the cross slide feed divisions. This is because you are reducing the radius of the workpiece by the indicated amount, which reduces the diameter by twice that amount. Therefore, when advancing the cross slide by .010", the diameter is reduced by .020".
- The diameter of the workpiece is determined by a caliper or micrometer. Micrometers are more accurate, but less versatile. Vernier calipers do not have a dial and require you to interpolate on an engraved scale. I prefer a dial caliper which gives a direct easy-to-read and hard-to misinterpret measurement.



Lean Manufacturing Mentor Guide

- It should be self-evident that you should never attempt to measure the workpiece while it is in motion. With the lathe stopped, bring the dial caliper up to the end and use the roller knob to close the caliper jaws down on the workpiece. Try to use the tips of the caliper since they are thinner.
- Take an initial reading of the dial while it is still gripping the workpiece since it is easy to inadvertently twist the caliper when removing it, thus changing the reading. You can use the locking screw on the caliper to help prevent this. Slide the jaws straight off the workpiece being careful not to twist the caliper.
- It's a good idea to take at least two separate measurements just to make sure you got it right. As it turns out it's much easier to remove metal than it is to put it back.

□ Turning a Shoulder

- A shoulder is a point at which the diameter of the workpiece changes with no taper from one diameter to the other. In other words, there is a 90 degree face moving from one diameter to the other.
- If the tip of the tool is rounded, the inner edge of the shoulder takes on a rounded profile.
- To get a nice square edge we must switch to a tool with a sharp point ground to an angle of less than 90 degrees so that it can work right down into the corner of the shoulder.

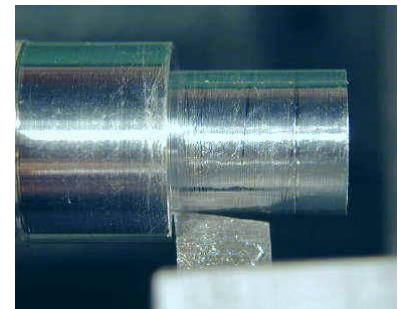
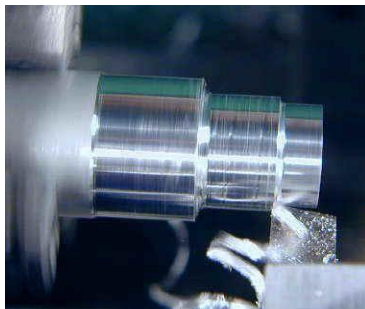
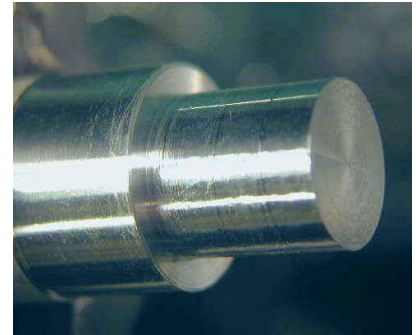

- Now we will use this pointed tool to make a square finishing cut into the corner of the shoulder. Since this is such a short distance, we will use hand feed, not power feed. You can use hand feed with the leadscrew turning - just don't engage the clutch lever.
- To get a nice square face on the shoulder you will need to make a facing cut. This works best if you have a carriage lock on your lathe. Lock the carriage and clean up the face of the shoulder until it is square. If you use the sharp pointed tool you will need to use fairly high RPM, and advance the tool slowly or you will get little grooves from the pointed tip instead of a nice smooth finish. You will need to use the carriage lock to lock the carriage in place for the facing cut.
- Finally, you may want to use a file as described in the facing section to make a nice beveled edge on outside edge of the shoulder and on the end of the workpiece.

Lean Manufacturing Mentor Guide

□ Drilling

- The alignment between the headstock and tailstock of the lathe enables you to drill holes that are precisely centered in a cylindrical piece of stock.
- Before you drill into the end of a workpiece you should first face the end as described in the facing operations section. The next step is to start the drill hole using a center drill - a stiff, stubby drill with a short tip. If you try to drill a hole without first center drilling, the drill will almost certainly wander off center, producing a hole that is oversized and misaligned.



□ Preparing to Drill

- Before drilling you need to make sure that the drill chuck is firmly seated in the tailstock. With the chuck arbor loosely inserted in the tailstock bore, crank the tailstock bore out. Lock the tailstock to the ways, and then thrust the chuck firmly back towards the tailstock to firmly seat the arbor in the Morse taper of the tailstock. (The chuck is removed from the tailstock by cranking the tailstock ram back until the arbor is forced out).
- Choose a center drill with a diameter similar to that of the hole that you intend to drill. Insert the center drill in the jaws of the tailstock chuck and tighten the chuck until the jaws just start to grip the drill. Since the goal is to make the drill as stiff as possible, you don't want it to extend very far from the tip of the jaws. Twist the drill to seat it and dislodge any metal chips or other crud that might keep the drill from seating properly. Now tighten the chuck. It's good practice to use 2 or 3 of the chuck key holes to ensure even tightening.
- Slide the tailstock along the ways until the tip of the center drill is about 1/4" from the end of the workpiece and tighten the tailstock clamp nut.



□ Cutting Fluid

- Always use a cutting fluid when drilling. Particularly with aluminum which tends to grab the drill, this helps to ensure a smooth and accurate hole.
- You only need a small amount at a time, so a small can should last for a long time. Use a small brush to apply oil to the workpiece.



□ Center Drilling

- Turn on the lathe and set the speed according to the type of used tool and required hole diameter. Use the tailstock crank to advance the drill slowly into the end of the workpiece and continue until the conical section of the center drill is about 3/4 ths of the way into the workpiece. This is as far as you need to go with the center drill since its purpose is just to make a starter hole for the regular drill. Back the center drill out and stop the lathe.

Lean Manufacturing Mentor Guide

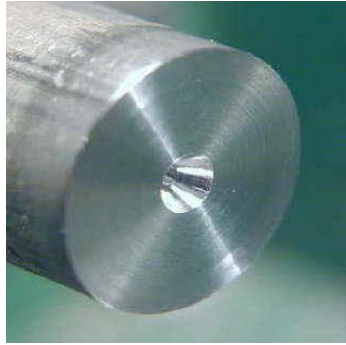

□ Drilling the Hole

- Loosen the tailstock clamp nut and slide the tailstock back to the end of the ways. Remove the center drill from the chuck and insert a regular drill and tighten it down in the chuck. Slide the tailstock until the tip of the drill is about 1/4" from the workpiece and then lock the tailstock in place. Place a small amount of cutting fluid on the tip of the drill, then start the lathe and drill into the workpiece as before.
- After advancing the drill about twice its diameter, back it out of the hole and use a brush to remove the metal chips from the tip of the drill. Add some more cutting fluid if necessary, and then continue drilling, backing the drill out to remove chips about every 2 diameters of depth.



□ Measuring Drilling Depth

- Unless you are drilling completely through a fairly short workpiece you will generally need a way to measure the depth of the hole so that you can stop at the desired depth.
- One way to measure the depth is to use the graduated markings on the barrel of the tailstock. These are not easy to see, though. If you need real accuracy, you could use a dial indicator.



□ Drilling Deep Holes, Blind Holes and Large Holes

- In the world of metalwork, a "deep" hole is any hole more than about 3 times the drill diameter. A blind hole is one in which you are not drilling all the way through the workpiece. The critical thing when drilling such holes is to frequently back the drill completely out of the hole to allow the chips to escape from the hole. You need to do this repeatedly each time you advance the drill by about twice its diameter. Failure to follow this procedure will cause the chips to weld to the drill and create a hole with an uneven and rough diameter. Cutting fluid will also help to keep the chips from binding to the drill or the sides of the hole.

□ Parting

- Parting uses a blade-like cutting tool plunged directly into the workpiece to cut off the workpiece at a specific length. It is normally used to remove the finished end of a workpiece from the bar stock that is clamped in the chuck. Other uses include things such as cutting the head off a bolt.
- Commercial Parting Tools
 - There is a wide variety of commercial parting tools, but most are too large. It is important for the top of a parting tool to be right on center.
 - Grinding a parting tool from a tool blank is a pain - since so much metal must be ground away - and parting tools get dull and break easily. This tool, and similar larger ones, use pre-formed cutting tools. If you break off the end, you just grind a new cutting edge and go on.



□ Custom Ground Parting Tools

- Grinding your own parting tool is not real difficult but it takes a long time and generates a lot of metal and grinder dust due to the relatively large amount of metal that you must remove from the blank. Here are some pictures of a typical home-ground tool. Note that the tool is tapered from top to bottom (like a narrow keystone) and from front to back to provide relief for the cutting tip. The top of the tool has been ground down by a few thousandths of an inch to align the top edge of the tool with the lathe centerline. If the toolholder comes with adjustable tool height, this would not be necessary. Forming the parting blade near the edge of the tool allows the tool to work up close to the chuck jaws.

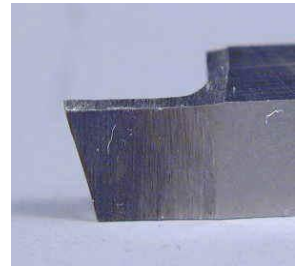
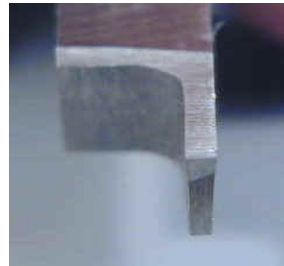

□ Chucking the Workpiece

- Parting is always done close to the chuck jaws - no more than 1/2" out, and, preferably, no more than 1/4" out. Parting cuts impose great tangential force on the workpiece that could cause the workpiece to be forced out of the chuck if you cut too far from the chuck jaws.

□ Adjusting the Tool Bit

- For a parting cut the top of the tool should be exactly on the center line of the lathe, or no more than .005 above the center line. If the tool is a little low it will have a tendency to 'climb' the work; a little high will cause a tendency to dig in. The tip of the tool should be perpendicular to the workpiece.

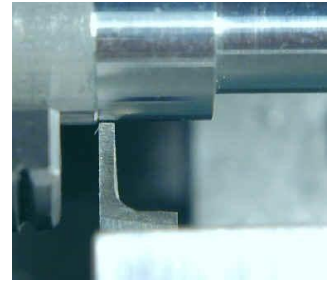

□ Speed and Feed

- Make sure the leadscrew is in the neutral position so that the leadscrew is not moving. Now lock the carriage clamp to keep the carriage from moving during the parting cut. Parting cuts should be made at low speed.

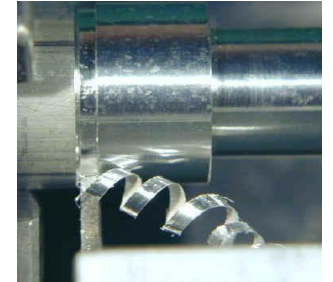

□ Making the Cut

- With the tip of the tool just beyond the surface of the workpiece, turn on the lathe. Slowly advance the cross-slide crank until the tool starts cutting into the metal. Keep advancing the tool until you get a steady chip curling off the workpiece and then try to maintain this cutting speed.
- It's a good idea to use cutting oil for a parting cut and you will find that the heat generated will most likely causes a fair amount of smoke as the cutting oil burns off. Avoid breathing this smoke; I'm sure it's not good for your lungs.

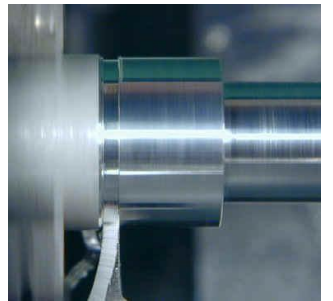

□ Chatter

- Parting often causes 'chatter'. If you have never heard this sound, you will easily recognize it when you first do. It is a pulsing, whining vibration that can shake the whole lathe. You can stop chatter quickly by backing off the pressure on the tool. The trick is to find the right speed at which to advance the tool with minimal chatter.
- Here are some tips to minimize chatter:

- Tool tip should be quite sharp
- Top of tool should be right on the lathe centerline
- Tool should be perpendicular to the workpiece
- Saddle should be snug to the ways
- Use carriage lock to lock saddle to ways
- Use cutting fluid
- Maintain steady advance of cross-slide

□ Finishing the Parting Cut

- Keep advancing the tool until it reaches the center of the workpiece. As you get close, the workpiece is suspended by a thin stalk of metal.

Lean Manufacturing Mentor Guide

- Be careful: if the workpiece extends from the chuck more than a few times its diameter, the end of the workpiece can start to swing in a dangerous arc. If you notice the workpiece starting to wobble, stop the lathe and move the workpiece back and forth by hand to break it free.

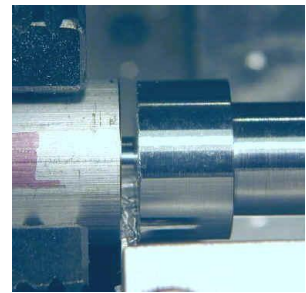

- The end of the workpiece that you cut off will generally have a pretty rough finish and a little stalk of metal protruding from the end. One limitation of parting tools is the diameter of the workpiece that can be parted and the edge of the workpiece got rounded because it was rubbing up against the shoulder of the cutting tool.

- The final step is to mount this piece in the chuck and make a facing cut to clean up the end. One problem with this step is that the chuck jaws can mar the finished workpiece. If you look carefully at the next picture you can actually see the imprint of the chuck jaws. To avoid this, you could wrap the workpiece in a thin strip of Emory paper, or similar protective material, before clamping it.



• Boring

- Boring is a lathe operation for forming internal holes in a workpiece using a tool designed specifically for that task. Here's an example of a shallow hole bored into the end of a piece of aluminum stock.
- Compared with drilling, boring has the following attributes:
 - Bored holes are typically more perfectly symmetrical than drilled holes.
 - Bored holes can be finished to any desired internal diameter greater than about 1/4" rather than being constrained by specific drill bit diameters.
 - Bored holes can be made to diameters much larger than is practical for drilled holes.
 - Bored holes can easily be formed with a flat bottom rather than the cone-shaped bottom typical of drilled holes
- For more information on Boring please refer to Boring Bar & Boring head under the Tools and Supplies on the Machine Shop Page on Mindworks.
- (http://www.webs1.uidaho.edu/mindworks/machine_shop.htm)

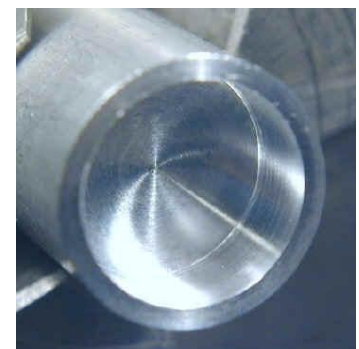
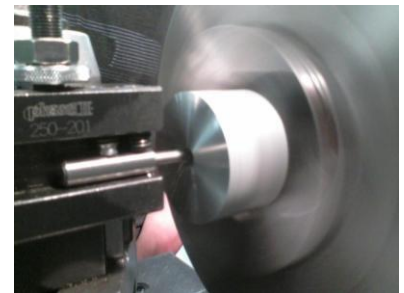

• Tapping & Threading

- Tapping is the process of cutting internal threads into a drilled hole by means of a special cutting tool known as a tap. Most of us who aspire to be home machinists have used taps even before we got into lathe workpiece, yet tapping remains one of the most difficult skills for many people.
- Particularly when working with small diameter taps such as 2-56 and soft materials such as aluminum, the risk of breaking a tap is always present. When a tap breaks off in workpiece into which you have invested hours or days of work, it is never a pleasant experience.
- Before cutting outside threads, turn down the workpiece to the major diameter of the thread to be cut and chamfer the end.
- To cut threads, move the threading tool bit into contact with the workpiece and zero the compound rest dial. The threading tool bit must be set at the right end of the workpiece; then, move the tool bit in the first depth of cut by using the graduated collar of the compound rest.
- Position the carriage half nut lever to engage the half nut to the lead screw in order to start the threading operation. The first cut should be a scratch cut of no more than 0.003 inch so the pitch can be checked. Engaging the half nut with the lead screw causes the carriage to move as the lead screw revolves. Cut the thread by making a series of cuts in which the threading tool follows the original groove for each cut.
- An internal threading operation (Tapping) will usually follow a boring and drilling operation; the same holder used for boring can be used to hold the tool bit for cutting internal threads. Lathe speed is the same as the speed for external thread cutting.
- The lathe can be used as a device to hold and align a tap or hand die to cut internal or external threads quickly for threads that do not require a high degree of accuracy or a fine finish.
- Tapping can be done on the lathe by power or by hand. Regardless of the method, the hole must be drilled with the proper sized tap drill and chamfered at the end. The shank end of the tap is supported by the tailstock center. A slight pressure is maintained against the tap to keep its center hole on the center and to help the cutting teeth of the tap engage the workpiece.

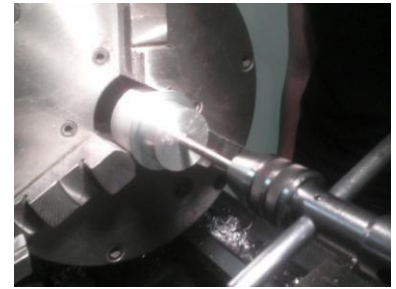

Lathe Project manufacturing plan

Part Number: 1 - 01	Quantity: 1	Material: Aluminum	Manufacturing Date: 5/21/2012
Part Name: Female lathe part		Stock: 2 dia x 1.5	5/22/2012
Part Description: Female lathe part: bored \varnothing 1.5 hole on one side, \varnothing 0.27" hole with countersink on other side			
Operation #	Machine Description	Operation Description	Tool Type
1	Manual Lathe	Chuck part in lathe and face rough side 1 (800 PM)	Cutter
2	Manual Lathe	Center drill	Center drill
3	Manual Lathe	Drill \varnothing 0.27 thru all (800 RPM)	I bit
4	Manual Lathe	Countersink to fit in screw (300 RPM)	1/5 x 82 \varnothing countersink
5	Manual Lathe	Reverse part, re-chuck, and face rough side 2 to a length of 1.0 (800 RPM)	Cutter
6	Manual Lathe	Bore center hole to \varnothing 1.051+0.003 to a depth of 0.75+0.02 (800 RPM)	Boring bar
7		Break edges (by hand)	File



Part Number: 1 - 02		Quantity: 1	Material: Aluminum	Manufacturing Date: 5/21/2012
Part Name: Male lathe part			Stock: 2" dia x 2"	
Part Description: Male lathe part: ¼-20 tapped hole on one side, □ 0.5 press fit on the other				
Operation #	Machine Description	Operation Description		Tool Type
1	Manual Lathe	Chuck part in lathe and face rough side 1 (800 PM)		Cutter
2	Manual Lathe	Cut grove 0.75-0.02 with dia of 1.500-0.001 (800 RPM)		Cutter
3	Manual Lathe	Center drill		Center drill
4	Manual Lathe	Drill □0.201 to depth of 0.75 (1200 RPM)		No. 7 bit
5	Manual Lathe	Tap hole to ¼-20 (by hand)		¼-20 tap
6	Manual Lathe	Reverse part, re-chuck, face rough side 2 and cut to length of 1.75 (800 RPM)		Cutter
7	Manual Lathe	Center drill		Center drill
8	Manual Lathe	Drill □0.25 to depth of 0.75 (1200 RPM)		¼ bit
9	Manual Lathe	Drill □15/32 to depth of 0.75 (900 RPM)		15/32 bit
10	Manual Lathe	Ream for press fit □0.499 to a depth of 0.6 all the way in, all the way out (450 RPM)		0.499 reamer
11		Break edges (by hand)		Deburring tool



Part Number: 1 - 05	Quantity: 1	Material: Aluminum	Manufacturing Date: 5/22/2012
Part Name: Grooved lathe pin		Stock: 0.5 dia x 4	5/22/2012
Part Description: Grooved lathe pin: long pin with four grooves for o-rings			

Operation #	Machine Description	Operation Description	Tool Type
1	Manual Lathe	Chuck part in lathe and face rough side 1 (800 PM)	Cutter
2	Manual Lathe	Reverse part, re-chuck, and face rough side 2 to a length of 3.5 (800 RPM)	Cutter
3	Manual Lathe	Center drill for live center	Center drill
4	Manual Lathe	Chuck part with room to cut all grooves and set up live center	
5	Manual Lathe	Cut four grooves with a width of 0.095 to a final diameter of 0.390 using special tool (800 RPM)	Custom cutting tool
6		Break edges (by hand)	



Lean Manufacturing Mentor Guide

General Mill Tips

- When running in low gear, reverse and forward are flipped, i.e. in low gear; reverse causes the tool to spin clockwise.
- File/debur part after each cut. This helps the finish as well as removes sharp edges that can cut you.
- Be sure to check the vise job of students that are new to the shop. Even if they follow each of the steps, they might not have tightened the vise enough on the part. While it seems like a very simple, straightforward task, if the part is not clamped in well enough, it can come out of the vise while the machine is running.
- When part is not centered in the vice, extra stock or a bolt and nuts can be used on the opposite side to ensure the vice remains straight when tightened.



Bolt is placed on the far end to ensure the jaws
remains parallel as it clamps the part

- If a part cannot fit in the vise, there are T-slots on the table of the mill in which you can insert T-shaped clamping nuts to hold bolts that can hold the part in place



- The diameter of our edge finders is .2". This means that when you are zeroing a part, you need to move .1" further after the edge finder kicks out in order to get the true zero. To zero a part, first approach the edge until the bottom of the edge finder centers itself with the shaft. Then, move the axis a hair more to cause the bottom to snap back out of alignment with the rest of the shaft. Once this is done, set the zero and finally move .1" further along the axis to account for the radius of the edge finder and reset the zero.
- To zero on the center of a part, use the edge finder to zero on one side of the part, then edge find on the opposite side. Without zeroing, your center line is the distance between these two divided by two.



Lean Manufacturing Mentor Guide

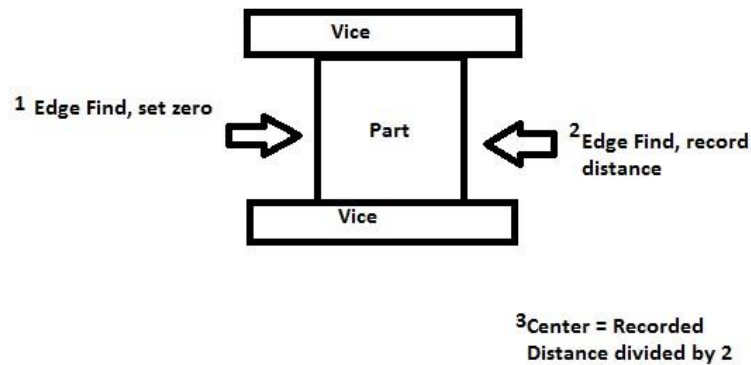

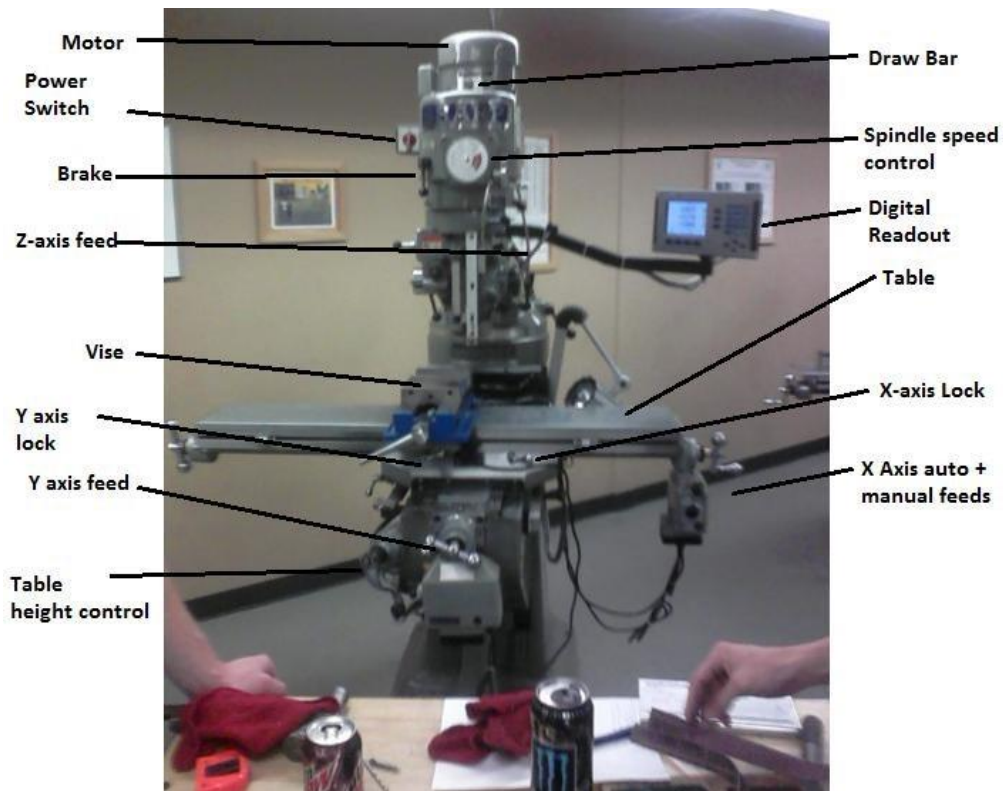

- If metal spirals are forming on your cutter, the handle of a brush can be used to remove them while machining.
- When removing a collet or chuck, hold the brake while you begin to loosen the drawbar with a wrench. When you are able to loosen it by hand, it is no longer necessary to hold the brake. After loosening the drawbar one turn by hand, you can hit it with a hammer to quickly pop the chuck/collet loose. If it takes more than one or two whacks with the hammer to knock the collet out, chances are you are tightening the drawbar too much when putting in your tool. Doing this can lead to stripped gears in the mill.
- To gain a better understanding of the mill, you will need to know the name of each component and where it is located. Reference the pictures below.



Lean Manufacturing Mentor Guide

Glossary of Mill Terms

1-2-3 Block	1"x2"x3" block used to help place part in vise. See Machine Shop page for more information.
Brake	Prevents the mill from rotating. Do not use while motor is running.
Center Drill	A short, stubby drill used to make the first cut when drilling a hole.
Chuck/ Collet	<ul style="list-style-type: none"> - Chuck is used for holding tools in the mill. Works really well for quickly changing tools such as drills, reamers, counter bores, etc. - Collet is used for holding tools like end mills in the milling machine. <div style="display: flex; justify-content: space-around; align-items: center;">   </div>
Drawbar	The bar used to hold a collet or chuck in place. When changing collet, hand tighten and then use a wrench to tighten about a quarter turn more. Tightening too much can damage the draw bar, while tightening too little can lead to the collet/chuck to be unsafe.
Digital Readout	This is used for accurate positioning. Shows x, y, and z location of the cutter in reference to the chosen origin.
Feed rate	The rate at which the table is moving.
Parallels	Bars used to hold a part above the top of the vise jaws when through cuts are being performed. Also can be used to ensure that the part is parallel in the vise.
Power Switch	Controls whether the spindle spins clockwise (forward) or counterclockwise (reverse). When in low gear, forward and reverse are switched.
Rapid Feed	A capability of the mill while using the automatic feed makes the table move much faster than it normally would. This is extremely useful when changing position of the cutter from one side of the piece to another. Never use while cutting material.
Reamer	A tool used for a precise diameter on drilled holes. Generally used for press and slip fits.
Spindle Rate	The rate at which the tool rotates (generally given in RPM)
Sp Speed Control	Used for adjusting the RPM of the cutting tool. Do not change unless the machine is running.
Table	Main component for supporting vise/clamping tools. If a part cannot fit in the vise, the vise can be removed and clamps may be used.
Table Height Control	This can manually adjust the table height. Doing so is NOT reflected on the digital readout; if the table height is changed, re-zeroing the part is required.
Vise	Used for holding parts in place during operations. Using a lead hammer, tap the part after clamping tight to ensure that the part is flat in the vise.

Lean Manufacturing Mentor Guide

X/Y axis feed	Our mills have the ability to be manually or automatically fed. Manual feeds are generally used for zeroing parts while automatic feed is used for milling parts to ensure a smooth cut.
X/Y axis lock	Used to lock the table in place. Particularly helpful when drilling holes to ensure the position of the drill does not change as you are changing parts.
Z axis feed	This controls the height of the cutter. If auto feed is desired in the z-axis, ask Russ for help. Generally only the manual feed is used by students.

Lean Manufacturing Mentor Guide

Mill Operations

- Operations that can be done on the mill

-Facing – Milling - Drilling – Counter Boring – Counter Sinking

Reaming □ Facing:

- Facing is the process of removing material from the surface of a work piece. The mill is best to use for parts that require a flat surface. Using the mill, you can easily square a surface of a part or ensure 90° angles on the part.
- Can be done using an end mill, fly cutter, or facing mill. When using an end mill or facing mill, general drilling speeds may be used. For a fly cutter, a speed of around 800 RPM is advised.



End Mill



Fly Cutter



Facing Mill

- All facing mills, except the fly cutter, are carbide; use appropriate speeds. For a fly cutter, use a spindle rate of about 800 RPM. When using an end mill, use the drilling speed shown on the charts in the shop.
- When facing, oil is not needed. Facing a part can cause it to get very hot due to friction; use coolant to help counteract this heating.

□ Preparing for the Facing Cut

- When clamping the part in, use parallels to ensure the block is on flat surface allowing the cut to be consistent throughout the face. Make sure that there is still enough material in the vise for it to sufficiently hold the part in place.
- When using an end mill to face, select one that is short and fat. This helps reduce chatter in the part while the cut is being made.

□ Roughing pass

- Make sure that the part is clamped in tightly. Roughing passes cause a lot of tangential stress on the part, which can cause the part to move in the vise if it is not clamped tightly enough.



a

- The new Aluminum Facing mill can take off 1/8" at a time. Other Facing mills and the fly cutters can take off .1" per pass. Do not cut more than this for either tool, as doing so can damage the tool, the mill, and ruin your part.
- Conventional cuts may be used for the roughing pass.
- *Rule of Thumb*: when facing with an end mill, do not take off more than half the diameter of the cutter per pass. Taking off too much at a time is bad for both the cutter and the mill itself as it can stall if too much is taken in one pass.
- Leave .01" above tolerance for the final pass. This allows you to climb cut for the final pass, which leaves a better finish. Also, having only .01" of material for the final pass reduces chatter allowing for a more accurate cut.
- If the part is screeching, try adjusting the feed rate. For aluminum, a feed rate of 4 inches per minute is a good starting point and for steel, 2 inches per minute is a good starting point for roughing.

□ Final Pass

- The final pass is used to make a smooth, accurate finish.
- Use a climb cut on the final pass to leave a good finish.
- Use auto-feed to ensure a constant feed rate. This prevents uneven cuts and leaves a nicer finish.
- Generally, using a slower feed rate for the final pass will leave a better finish. Because you are removing less material, it is acceptable to speed up the feed rate to make the finish better. However, increasing the feed rate too much will lead to a worse finish. If arcs in the part are relatively thick after the cut, your feed rate is too slow. If there are a lot of thin arcs, the feed rate is too fast.
- Generally, a good feed rate for a final pass is about half of what is used for roughing passes. As you get more familiar with the mill and have a feel for it, a combination of changing the spindle rate as well as the feed rate may be best; however this is the best starting point for new mentors.

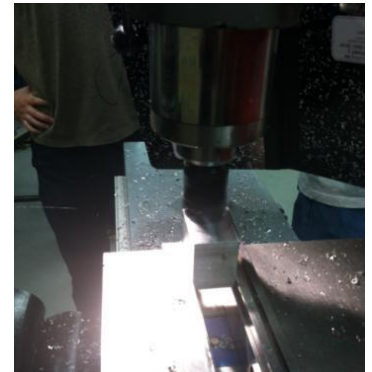

• Drilling

- Always use oil when drilling, except for cast iron.
- For small bits, speeds given on the chart are often quoted as RPMs that our mill cannot handle. If this is the case, keep the speed under the red zone on the speed dial to prevent the mill from overworking itself.
- Always start holes with a center drill. For holes over 1/2", drill with the holes with smaller drills in 1/4" increments. This prevents the bit from getting dull and size drilling too much at a time can also hurt the mill.
- Make sure to peck drill. Apply oil in between pecks as needed.

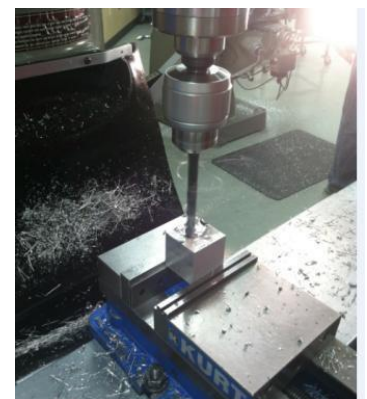

□ Steps for drilling

- Edge find and set the origin. Reference the general mill tips section for edge finding processes
- Center drill the part. This initializes the hole allowing the drill bits to easily cut through the material.
- Drill the hole. Be sure to peck drill (drill in a little bit, then come back out) and apply oil as needed to keep the bit from getting dull as well as help ensure a smooth finish.
- Step up bit size if over $\frac{1}{2}$ ". This ensures that the mill does not try cutting too much material for the drill bit to handle. If stepping up size is required, steps of about $\frac{1}{4}$ " each step are advised.



• Reaming

- A reamer is a tool used when an extremely precise diameter hole is needed, such as a hole for a press or slip fit.
 - A hole can be reamed after the drilling process is completed. This is generally done for press and slip fits as it makes the hole accurate to .0003".
 - Peck drill when reaming if the part is thicker than 1".
 - To ensure a smooth ream, reaming in and out two or three times is advisable.
 - Ream at $\frac{1}{2}$ the drilling RPM.
 - Use cutting oil.
 - Reference the Machine Shop website for proper reamer sizes to use as well as hole diameter to drill to before reaming.



• Counter Sinking

- Counter sinking is used to allow screws to be flush with the face of the part. It leaves a conical shape to match countersunk screws that have the same conical shape. It's also used to deburr drilled holes.
- In order to counter sink, a hole in which you want the counter sink must first be drilled.
- Most counter sinks in the shop are 82° . This matches the angle on the flat head screws that are stocked.
- When counter sinking a hole, the spindle rate should be very low (about 100-200 RPM).



- **Counter Boring**

- Much like counter sinking, counter boring is used to cut material so that screws can be flush with the face of the part. Counter boring is used on screws that have an elongated head that is a larger diameter than the body.
- Counter bores have pilots to help guide them into existing holes. When you are going to counter bore, you first need to drill the hole so that this pilot can follow the hole as you drill to the desired depth. This ensures the counter bore and the original drilling operation form concentric holes, allowing a screw to be inserted into the hole.
- When counter boring, use the drill speed of the larger diameter of the tool (the diameter that you are boring to).



Mill Project manufacturing plan

Part Number: 2 - 01	Quantity: 1	Material: Aluminum	Manufacturing Date: 5/15/2012 5/16/2012 5/17/2012
Part Name: Bottom block		Stock: 2" x 2" x 2"	

Part Description:

Bottom block: getting it square and drilling out large hole

Operation #	Machine Description	Operation Description	Tool Type
1	Manual Mill	Face smooth side 1	Fly cutter
2	Manual Mill	Flip part and face bottom smooth side	Fly Cutter
3	Manual Mill	Face front smooth side	Fly Cutter
4	Manual Mill	Face rear smooth side	Fly Cutter
5	Manual Mill	Face rough side 1	End Mill
6	Manual Mill	Face rough side 2	End mill
6		File down all rough edges (by hand)	File
7	Manual Mill	Set block on parallels in center of vise and edge find in the X and Y	Edge finder
8	Manual Mill	Center drill up to shoulder	Center drill
9	Manual Mill	Drill $\square 1/4$ thru all, pecking (2400 RPM)	$1/4$ bit
10	Manual Mill	Drill $\square 1/2$ thru all, pecking (1200 RPM)	$1/2$ bit
11	Manual Mill	Ream to $\square 0.505$, all the way in then out (600 RPM)	0.505 reamer
12		Break edge (by hand)	Deburring tool

File down cut edges after every cutting operation for each milling process before continuing to the next operation.



Part Number: 2 - 01	Quantity: 1	Material: Aluminum	Manufacturing Date: 5/15/2012 5/16/2012 5/17/2012
Part Name: Bottom block		Stock: 2" x 2" x 2"	

Part Description:

Bottom block: Milling out groove and drilling out small holes

Operation #	Machine Description	Operation Description	Tool Type
12	Manual Mill	Set block on parallels in center of vise and edge find in the X and Y	Edge finder
13	Manual Mill	Place 5/8 end mill in the collet and zero in the Z	5/8 end mill
14	Manual Mill	Mill the groove leaving taking off 0.1 each pass until within ± 0.01 of final depth (1200 RPM)	5/8 end mill
15	Manual Mill	Make a finishing pass on each side taking of remaining material making sure to climb cut for best finish (1200 RPM)	5/8 end mill
16		File down all rough edges (by hand)	File
17	Manual Mill	Re-zero in the X and Y if needed	Edge finder
18	Manual Mill	Center drill the middle hole	Center drill
19	Manual Mill	Drill ± 0.120 to depth of 0.3 (2800 RPM)	No. 7 bit
20	Manual Mill	Ream ± 0.124 to depth of 0.3 all the way in then out (1800 RPM)	0.124 reamer
21	Manual Mill	Center drill edge hole	Center drill

22	Manual Mill	Drill $\square 0.2$ to a depth of 1.0 (2500 RPM)	0.2 drill bit
23	Manual Mill	Center drill other edge hole	Center drill
24	Manual Mill	Drill $\square 0.2$ to a depth of 0.65 (2500 RPM)	0.2 drill bit
25	Hand	Break edges (by hand)	Deburring tool
26	Hand	Tap outside holes to $\frac{1}{4}$ -20 (by hand).	$\frac{1}{4}$ -20 tap



Part Number: 2 - 02	Quantity: 1	Material: Aluminum	Manufacturing Date: 5/15/2012 5/16/2012 5/17/2012
Part Name: Top block		Stock: 2" x 2" x 1.5"	

Part Description:

Top block: getting it square and milling out notch, and drilling large hole

Operation #	Machine Description	Operation Description	Tool Type
1	Manual Mill	End mill rough side 1 (1200 RPM)	$\frac{3}{4}$ end mill
2	Manual Mill	Flip part and face rough side 2 to a width of 1.376 (1200 RPM)	1.5 inch facing mill
3	Manual Mill	Flip part and face side 2.00 width (1200 RPM)	1.5 inch facing mill
4	Manual Mill	Flip part and face side 1.75 width (1200 RPM)	1.5 inch facing mill
5		File down all rough edges (by hand)	File
6	Manual Mill	Set block on parallels in center of vise and edge find in the X and Y	Edge finder
7	Manual Mill	Place $\frac{5}{8}$ end mill in the chuck and zero in the Z	$\frac{5}{8}$ end mill
8	Manual Mill	Mill the notch leaving $\square 0.01$ on the side and taking off 0.3 each pass until within $\square 0.01$ of final depth (1200 RPM)	$\frac{5}{8}$ end mill

9	Manual Mill	Make a finishing pass taking of remaining material making sure to climb cut for best finish (1200 RPM)	5/8 end mill
10	Manual Mill	Set block on parallels in center of vise and edge find in the X and Y	Edge finder
11	Manual Mill	Center drill up to shoulder	Center drill
12	Manual Mill	Drill $\square 1/4$ thru all, pecking (2400 RPM)	$1/4$ bit
13	Manual Mill	Drill $\square 1/2$ thru all, pecking (1200 RPM)	$1/2$ bit
14	Manual Mill	Ream to $\square 0.505$, all the way in then out (600 RPM)	0.505 reamer
15		File down rough sides and break edge (by hand)	Deburring tool



Part Number: 2 - 02	Quantity: 1	Material: Aluminum	Manufacturing Date: 5/15/2012 5/16/2012 5/17/2012
Part Name: Top block	Stock: 2" x 2" x 1.5"		

Part Description:

Top block:

Drilling out large hole and drilling small holes

Operation #	Machine Description	Operation Description	Tool Type
11	Manual Mill	Re zero in the X and Y if needed	Edge finder
12	Manual Mill	Center drill the middle hole	Center drill
13	Manual Mill	Drill $\square 0.120$ thru all pecking (2800 RPM)	No. 7 bit
14	Manual Mill	Ream $\square 0.126$ thru all going all the way in then out (1800 RPM)	0.126 reamer
15	Manual Mill	Center drill edge hole	Center drill
16	Manual Mill	Drill $\square 0.266$ thru all (2500 RPM)	0.266 bit

17	Manual Mill	Center drill other edge hole	Center drill
18	Manual Mill	Drill $\square 0.266$ thru all (2500 RPM)	0.266 bit
19		Flip the part in the vise	$\frac{1}{4}$ -20 tap
20	Manual Mill	Countersink until screw fits	0.5 by 82 \square countersink
21	Manual Mill	Counterbore until screw fits $\square 0.25$	0.44 counterbore
22		Break edges (by hand)	



HASS CNC Mill Setup

The HASS CNC (Computer Numerically Controlled) Mill is a standard 3 axis mill (with optional 4th axis), that receives code to produce parts. The advantages of a CNC mill is higher accuracy/precision, repeatability, and ability to machine complex shapes (curves, angles, etc.). The main disadvantage is the setup time required, and initial learning curve. This section of the guide is covers the setup of the mill from power up, until you are ready to make chips.

Startup Procedure

1. Press "On" button



2. Wait for warning and press the "main reset button" (may need to be repeated)



3. Disable Safety override

- a. Press “setting” button
- b. Use arrow keys or number keys to navigate to 51
- c. Use arrow keys to toggle on and off



4. Install tools and find zeros (other part of guide)

5. Receive a program by pressing the “List” then “RCV” as seen below



6. Install side cover

- a. Normally stored near back right of machine
- b. Cover is placed on studs seen below (3 of 4 are visible, picture is rotated 90 degrees clockwise)



7. Turn on coolant by pressing the “coolant” button
 - a. If coolant is clear or foaming refer to coolant section of this guide
 - b. Ensure coolant is aimed towards tool



8. Close front cover

At this point machining could occur if the “Cycle Start” button was pressed. However one or more of the following processes may be recommended.

Graphical Practice Run

1. Press the “setting” button twice
2. Press the “Cycle Start” button and watch the screen

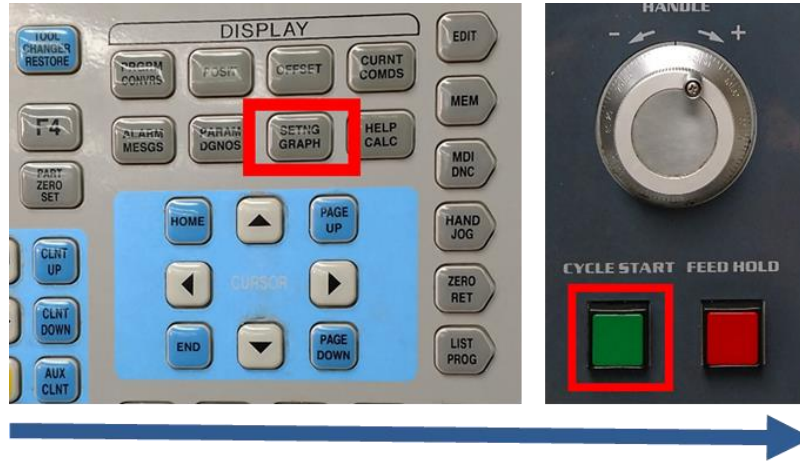

Air Practice Run

1. Set z offset so tool will not make contact with the stock or vise. For example if the endmill will plunge to a depth of 1.75 inches, set an offset of at least 1.75 inches.
2. Run program
 - a. Check for proper depths
 - b. Ensure tool paths are in approximate location, and will not collide with vise/table
3. Remember to reset z offset

Editing Code on Mill

1. Press “edit” button
2. Now you can edit the G-Code
 - a. Use the dial to move through the code
 - b. If lines are numbered, numerical inputs are also accepted



Starting Program midway through operations

1. Press "edit" button
2. Move to line you wish to start from
3. Press "current command" button

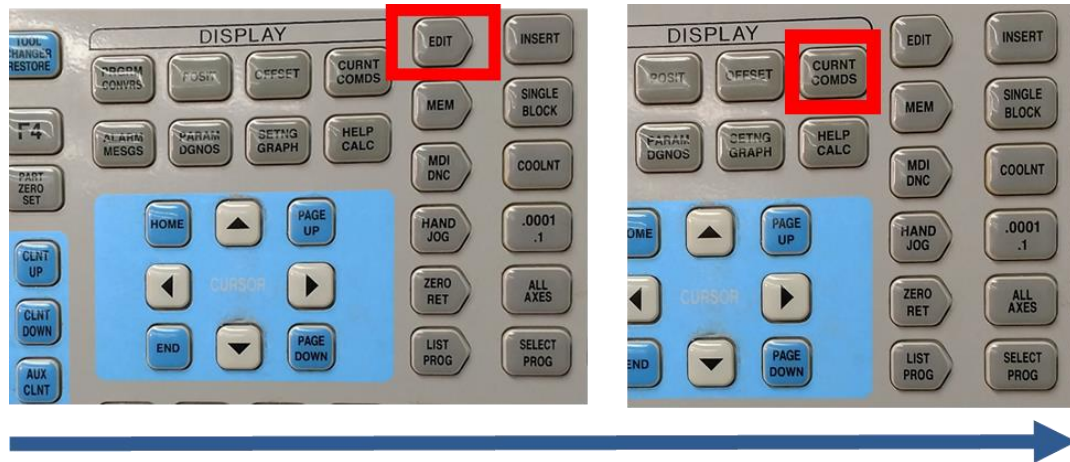

Coolant

1. Coolant is located in the back of the shop
2. Ratio is given in back of shop
3. Use a 5 gallon bucket to mix the coolant
4. Pour into coolant reservoir

CAM Setup

CAM stands for Computer-aided manufacturing, and is used to interpret a CAD file into G-Code for the CNC mill (or lathe) to use. The primary CAM program at the University of Idaho is Mastercam. This section covers the machine side tips and tricks. It also assumes you have already identified the types of tools needed.

Datum Point

- Set a measurable datum point that is easily accessible during the machining process. Remember you might need a datum for each orientation.
- Datum point may be removed during operations
- Coolant removes sharpie so be able to identify unmarked datums

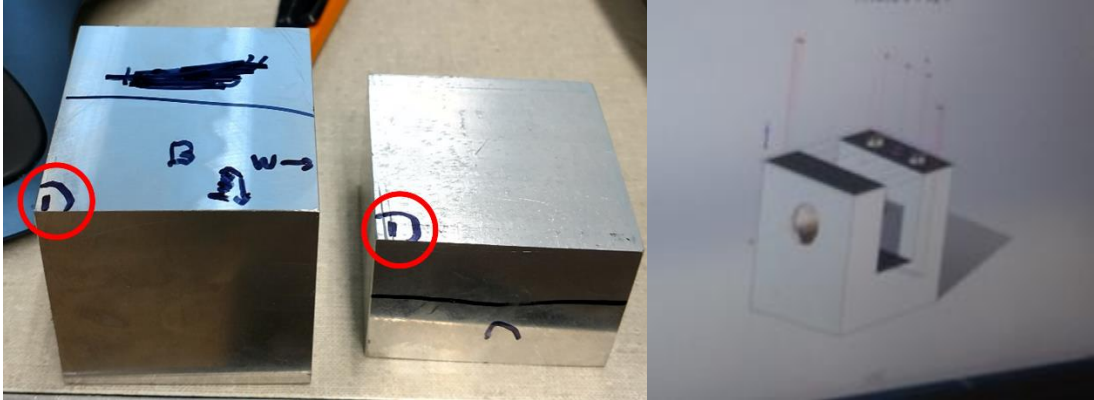

Tooling

- The automatic tool changer can hold ten tools, however there is always an edge finder in the tool magazine.
- Record the number you assign to each tool in the CAM software. For example if you define a ½ inch end mill as position 4 in CAM, you must put the ½ inch end mill in position 4 on the automatic tool changer.
- Ensure that the tool is properly sized lengthwise for the part.
 - Can the tool reach the whole depth or length of the feature?
 - Yes, then ensure tool is not of excessive length
 - No, get a new tool that will fit
- Define the proper feed and speed rate for the tooling
 - Comes from chart in shop, IEW, or online
 - Feed rate can be changed in progress on machine
 - The max spindle RPM of the HASS mill is 4000 RPM
- Refer to Mindworks wiki (and other section of guide) for installation process
 - [http://mindworks.shoutwiki.com/wiki/Mounting_Tools_\(HAAS_Mill\)](http://mindworks.shoutwiki.com/wiki/Mounting_Tools_(HAAS_Mill))

PART SET UP

Install and zero vise

For this operation, the worker has to place the vise and its bolts to the mill's table. The user need tighten one of the vise's bolts. Then the user needs a dial indicator and lead hammer to zero the vise. They then follow the procedure below.

1. Move feeler head of dial indicator to make contact with the vise's teeth/clamp
2. Move the dial indicator through X axis from left to right vise versa
 - a. Try to keep the dial indicator reading zero or around zero
3. If the indicator reads more than zero, the user has to use the hammer to push the vise from the free side.
Move the vise moves again left or right to make the reading zero.

Tools needed:

- Dial indicator.
- Lead Hammer (or equivalent)
- Wrenches.



Dial indicator



CNC's vise

Finding Part Zeros

When a person wants to use the CNC Mill machine, he/she surely have to set up the zero axis through relation datum point. The user has to bring the edge finding tool and put it in the CNC's chuck. To starting, user has to choose the axis whatever X or Y to find the zero. However, the Z axis zero will be with tool length operation. Through measuring, worker use spindle to move the spindle height (Z axis) to find the correct vertical zero.

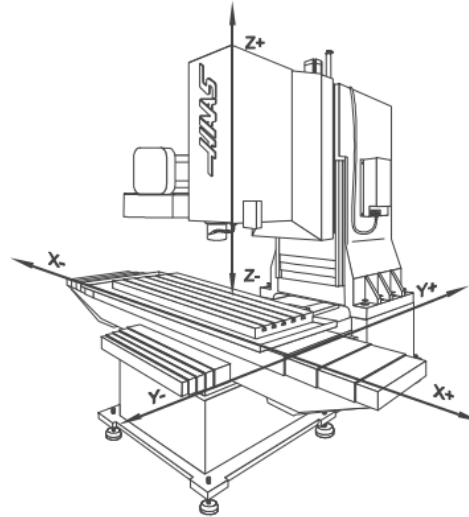

To manually move the mill in X, Y, or Z, the user must use hand jog mode. This mode is reached by pressing the hand jog button. Then press jog lock, and then the axis you wish to move in. The example below show a hand jog in the x direction.



The speed of the hand jog is modified with the buttons next to the "Hand Jog" button. One dial tick, is one increment of movement. For example if 0.001 is selected, one tick of the machine will move the table 0.001 inch in the selected direction. *Care must be taken, as table movement lags behind dial speed. Therefore if the increment is too high, and the dial is moved too quickly then a collision may occur.*

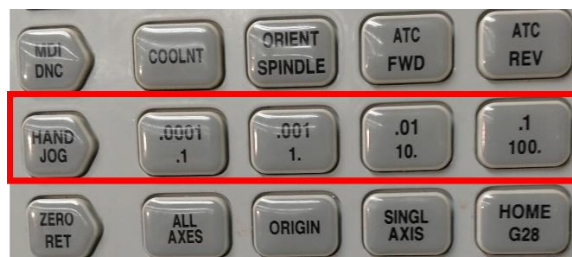

Finding X and Y zero

1. Press "M.D.I" button
2. Enter speed to be 1000
3. Hit "clockwise" or "counterclockwise"
4. Use hand jog to locate the X zero
5. Press "Offset".
6. Part zero set.
 - a. Remember to account for radius of edgefinder
7. Repeat for Y axis
8. You can check your X,Y zero by manually moving to it



Finding Z zero

When a user puts tools in the CNC, they have to ensure the zero for each tool. So, they have to use the feeler gauge to set up the Z zero so the part and tool are not damaged. Users need to use hand jog to move in the Z direction. The user moves the feeler gauge left and right until it gets hard to move, and this becomes the Z zero. Remember to correct for the feeler gauge thickness. Below is a more detailed procedure.

1. Press "Tool Offset Measure."
2. Put the machine in hand jog mode
3. Go down with .01 speed until the feeler gauge cannot run under the tool
4. Set the speed to 0.001, until the feeler gauge can barely run under the tool
 - a. If higher accuracy is required do down with 0.0001 speed
5. Press "Tool Offset Measure"
6. Compensate for feeler gauge thickness
7. Move to next tool
8. Tool Offset Measure
9. Repeat steps from #3 to #6 for all tools



Automatic tool change:

The CAM program tells the machine what tool to grab for each operation. However the user must pay attention and ensure the proper tool is selected. For example on the block project the machine needed to drill a ¼ inch hole, but grabbed the edgfinder instead.



The user should *ALWAYS* have their hand on the “Feed Hold” button. In case, if the user notes any wrong steps or choose tools, he/she has to press first “Feed Hold and” second step press “Stop” to safely shutdown the process.



Tools changing operation



Tools numbers



Chucks

Manually changing tools

1. Press “MDI/ DNC”
2. Press “ATC/FWD”
(when choosing the ATC/FWD it will change as series operation for example 1, 2, ...etc.)
3. Typing the tool number.
4. Press “Enter”

Installing tools:

Installing tools is a manual operation, which requires careful and deliberate actions to ensure no tools are broken.



The spindle

Tool release

Installing tool

Procedure

1. Hold "Tool Release"
2. Bring the tool and put it in the spindle
3. Let go "Tool Release" bottom.

General Safety Welding Tips

Shown below is an image of the layout of the welding section at the machine shop.

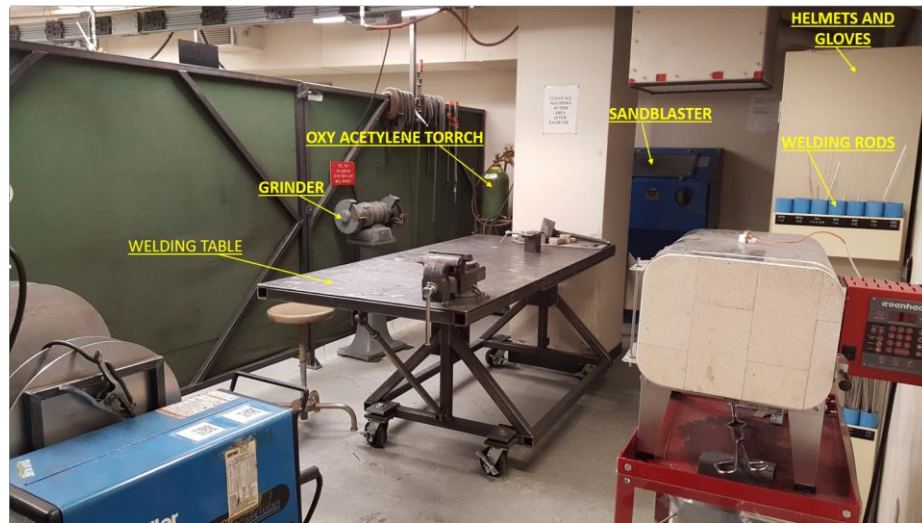

Apparel:

- All skin should be covered by non-synthetic fabric-polyester and the like; they will melt to the skin. A lab coat is available for your use. Exposed skin will get sunburned from the electrical arc flash.
- Leather gloves shall also be worn to protect hands whenever welding. ***"Caution- do not handle hot metal with gloves use the pliers"***.

Helmet

- MIG Welding needs to have a Number 10 Lens; TIG welders can uses a Number 9 or 10 lens; "Higher the number the darker the lens"



DO NOT WELD!

- **Do not** weld any metal with plating such as: Galvanized Metal (can result in Galvanize poisoning, which is a condition that results from the over exposure to zinc oxide), Chrome, Cad-plated, etc.
- **Do not** weld any metals that hold or have been in contact with: Flammable liquids, Gas Tanks, oil pans, etc.

TIG WELDING (Tungsten Inert Gas)

TIG stands for Tungsten Inert Gas, the Tungsten refers to the Tungsten electrodes that are used to weld, while the Inert Gas refers to the Argon gas used while welding which prevents the welds from corroding.

Uses for TIG

- TIG welding can be used to weld Magnesium, Aluminum, Steel, Stainless Steel, Brass Alloys, Silver, Cast Iron, and Copper.
- Use TIG for thin Sections and metals that cannot be easily welded with other types of welding.



Getting Started with TIG



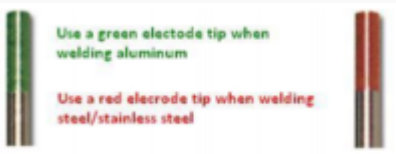

Prepare Metal and Welding Table.

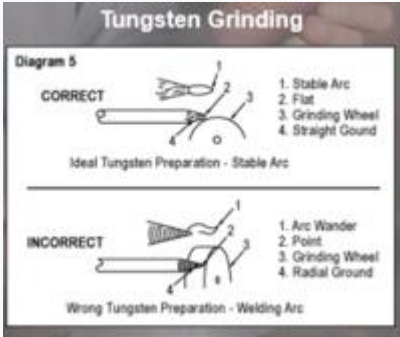
- Use a wire brush to scrub the surfaces of the metal. Clamp the metal so that it will stay stationary while welding.
- The metal can also be bead blasted to clean the surfaces before welding.
- Make sure to ground the machine on the shop welding table before welding!

Setting up the Machine for different Metals

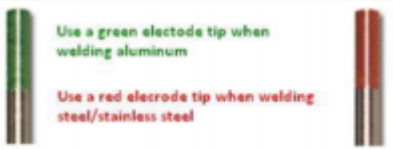
Steel Metal	Description
 <p>Dial to show settings for Steel</p>	<p>Use DC straight polarity and an electrode with a Red tip end(2% Thoriated). When welding steel with DC straight polarity make sure the tip is ground to a conical point</p>
 <p>TIG tip Red for Steel</p>	<p>The RED tip is used for steel</p>

 <p>Correct Tip Incorrect Tip</p> <p>$\approx 2.5 \times \text{Diameter}$</p> <p>TIG Steel tip</p>	<p>Make sure tip is free from build up and ground to a fine point</p>
 <p>Tungsten Grinding</p> <p>Diagram 5</p> <p>CORRECT</p> <ol style="list-style-type: none"> 1. Stable Arc 2. Flat 3. Grinding Wheel 4. Straight Grind <p>Ideal Tungsten Preparation - Stable Arc</p> <hr/> <p>INCORRECT</p> <ol style="list-style-type: none"> 1. Arc Wander 2. Point 3. Grinding Wheel 4. Radial Grind <p>Wrong Tungsten Preparation - Welding Arc</p> <p>Creating Tip</p>	<p>Use machine sharpening grinder to grind to a point</p>  <p>Use the grinder in the welding area pictured above</p> <p>DO NOT USE THE GRINDER ON THE SHOP FLOOR</p>
<p>TIG Setup for Aluminum:</p>	
<p>Aluminum Metal</p>	<p>Description</p>
 <p>Dial to show settings for Aluminum</p>	<p>Use AC Current and an electrode with a Green tip end (100% Tungsten) Ensure that the tip is rounded properly</p>

 <p>Use a green electrode tip when welding aluminum Use a red electrode tip when welding steel/stainless steel</p> <p>TIPS Green is used for Aluminum</p>	<p>Color Coded tips Green is used for Aluminum</p>
 <p>Correct Tip Incorrect Tip</p> <p>Creating tip for Aluminum</p>	<p>Aluminum tip should like this before welding</p>
 <p>Tungsten Grinding</p>	<p>Preparing Aluminum Electrode</p> <ul style="list-style-type: none"> • Set amperage to max setting Hold • Electrode 1/8 inch from copper and press pedal • Heat generated causes tip to melt in to smooth ball
 <p>Aluminum Specifications</p>	<p>Choose correct electrode and filler rod based on the type of material and thickness of weld</p>

Listed below are the specification of different tips:-

Pure Tungsten (Color Code: Green)

- 99.5 % pure Tungsten
- Provide great arc stability for AC welding with a balanced wave.
- Not typically used for DC welding because it does not provide the strong arc starts associated with thoriated or ceriated electrodes.

Thoriated (Color Code: Red)

- 97.30 percent tungsten and 1.70 to 2.20 percent thorium
- These electrodes are used mainly for specialty AC welding (such as thin-gauge aluminum and material less than 0.060 inch) and DC welding, either electrode negative or straight polarity, on carbon steel, stainless steel, nickel, and titanium.

Lanthanated (Color Code: Gold)

- 97.80 percent tungsten and 1.30 percent to 1.70 percent lanthanum
- Unlike thoriated tungsten, these electrodes are suitable for AC welding and, like ceriated electrodes, allow the arc to be started and maintained at lower voltages.
- They work well on AC or DC electrode negative with a pointed end, or they can be balled for use with AC sine wave power sources.

Zirconiated (Color Code: Brown)

- 97.80 percent tungsten and 1.30 percent to 1.70 percent lanthanum
- Unlike thoriated tungsten, these electrodes are suitable for AC welding and, like ceriated electrodes, allow the arc to be started and maintained at lower voltages.
- They work well on AC or DC electrode negative with a pointed end, or they can be balled for use with AC sine wave power sources.

For other materials

Consult welding reference or experienced welder.

NOTE:

- *Amperage varies depending on the material thickness and type of weld*

Welding Techniques

TIG Welding Techniques:

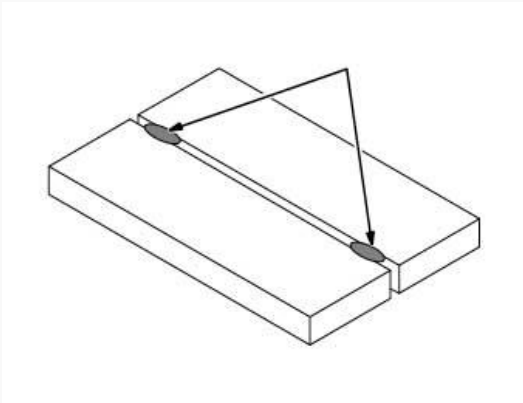
Image of Technique	Description
<p>Test</p>	<p>Test weld on scrap metal to get a feel for the weld and to insure everything is running properly.</p>
	<p>Tack the two pieces of metal first. This can be completed by depressing the foot pedal quickly to create a weld pool then bringing the rod in. Now the clamps can be removed.</p> <p>Insure to weld both sides evenly, to insure no warping occurs due to excessive heat</p>

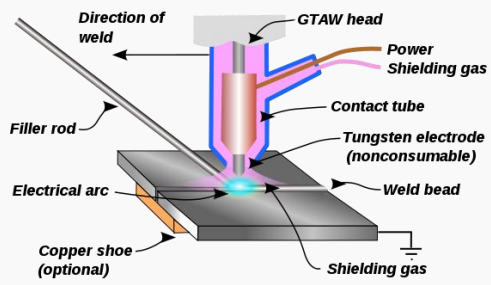
<p>Tack pieces together</p>	
 <p>Tig Weld</p>	<p>Hold the electrode about an inch away from the metal. Never touch the metal with the electrode. If you do, molten aluminum will leap onto the electrode. If this happens, stop, turn off the welder, remove the tungsten rod, and grind it down</p>

MIG (Metal Inert Gas)

For Safety refer to General Safety Tips above for Welding

Setting up MIG Welder

MIG Welding Set up:





Settings	Description																																																
 <p>MIG Dial Controls (Wire Feed and Temperature)</p>	<p>Settings</p> <ul style="list-style-type: none"> Choose the Correct wire gauge based on the type of material and thickness of weld. Set wire speed and thickness dials to appropriate settings (Proper settings to the thickness of metal to be welded are located under the hood of the welder) Ground welder to table or work to be welded Turn on CO₂ tanks for the inert gas shield Turn on the MIG Welder Turn on the ventilation hood using the switch on the wall 																																																
<table border="1" data-bbox="170 1764 820 1900"> <thead> <tr> <th></th> <th colspan="7">Material Thickness</th> </tr> <tr> <th></th> <th>5/16"</th> <th>1/4"</th> <th>3/16"</th> <th>1/8"</th> <th>14 ga.</th> <th>16 ga.</th> <th>18 ga.</th> </tr> </thead> <tbody> <tr> <td>Voltage Range</td> <td>High</td> <td>High</td> <td>High</td> <td>Low</td> <td>Low</td> <td>Low</td> <td>Low</td> </tr> <tr> <td>Wire Mode</td> <td>Full</td> <td>Low</td> <td>Low</td> <td>Low</td> <td>Low</td> <td>Low</td> <td>Low</td> </tr> <tr> <td>Thickness</td> <td>3</td> <td>2</td> <td>1</td> <td>5</td> <td>4</td> <td>3</td> <td>2</td> </tr> <tr> <td>Wire Speed</td> <td>60</td> <td>60</td> <td>51</td> <td>45</td> <td>48</td> <td>41</td> <td>30</td> </tr> </tbody> </table> <p>settings that are found under welder hood</p>		Material Thickness								5/16"	1/4"	3/16"	1/8"	14 ga.	16 ga.	18 ga.	Voltage Range	High	High	High	Low	Low	Low	Low	Wire Mode	Full	Low	Low	Low	Low	Low	Low	Thickness	3	2	1	5	4	3	2	Wire Speed	60	60	51	45	48	41	30	<p>This Diagram tells you what to set the welder to by thickness of metal</p>
	Material Thickness																																																
	5/16"	1/4"	3/16"	1/8"	14 ga.	16 ga.	18 ga.																																										
Voltage Range	High	High	High	Low	Low	Low	Low																																										
Wire Mode	Full	Low	Low	Low	Low	Low	Low																																										
Thickness	3	2	1	5	4	3	2																																										
Wire Speed	60	60	51	45	48	41	30																																										

Setting up Material to be Welded

- Prep Surface to ensure a clean strong weld by wire brushing or grinding
- Put on all safety gear
- If the wire is protruding 1 cm past the nozzle, break it off on the table. **DO NOT** leave it stuck to the table
- Ensure others around know that you are welding by saying "COVER"

Welding Techniques

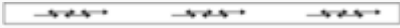
MIG Welding Techniques:

Image of Technique	Description
 <p data-bbox="164 1226 334 1255">Angle of Weld</p>	<p data-bbox="586 835 1503 898">Welder should be as close to perpendicular to the surface, and angled 20-30 degrees in the direction of travel shown</p>
 <p data-bbox="164 1577 420 1606">Shows Push and Pull</p>	<p data-bbox="586 1331 1479 1394">This is welder travel direction. Push is stronger, with more penetration in thick metals.</p> <p data-bbox="586 1430 1338 1459">Pull is weaker and with less penetration; good for thin metals</p>
 <p data-bbox="164 1724 342 1753">Stitch Welding</p>	<p data-bbox="586 1656 1516 1782">Technique used to create strong welds with less distortion than a full length weld. Welder is placed in position, trigger pulled, and welder is moved back and forth motion for approximately an inch; an inch is skipped then process repeats.</p>
 <p data-bbox="164 1923 407 1953">Full Length Welding</p>	<p data-bbox="586 1797 1503 1892">Highest strength weld, but most heat distortion and residual stresses. Welder is placed in position, trigger pulled, and moved in either a crescent moon path, or back and forth.</p>

 <p>Too Fast Too Slow</p> <p>Fast and Slow Welding</p>	<p>Results of Fast and Slow Welds</p>
---	---------------------------------------

Shutting down Welder and Clean up of Area

<p>MIG Welding Techniques:</p>	
<p>Cleaning the TIP</p>	<p>General shutting down and cleaning</p>
 <p>MACHINE CLEANING</p> <ol style="list-style-type: none"> 1. Slide gas nozzle from end of wand 2. Clear away all material inside nozzle and around contact tip and gas diffuser ensuring diffuser holes are clean. 3. Wrench tighten gas diffuser; Hand-tighten contact tip 4. Spray Nozzle-Shield into end of gas nozzle to prevent splatter buildup <p>**Excessively worn parts should be replaced** **See Russ**</p> <p>Cleaning Advice for MIG Welder</p>	<p>Turn off the MIG welder</p> <ul style="list-style-type: none"> • Close the valve on CO₂ tank • Wrap ground cable around welder • Wrap welder torch around the welder • Unplug welder from the outlet and wrap cord around the welder • Turn off the ventilation fan with the switch on the wall • Put away Helmet, gloves, and shop coat • Refer to Picture of Cleaning for the Machine

Shielded metal arc welding (Stick welding)

- SMAW is a manual arc welding process that uses a consumable electrode covered with a flux to lay the weld.

When to use SMAW?

- If you are welding indoors, any process will work. If welding outside, you can forget about MIG and TIG for the most part, as there are only a few exceptions.

What each electrode is good for.

- 6010 deep penetration works well in all positions and is excellent on dirtier metals.
- 6011 deep penetration works well in all positions and is excellent on dirtier metals.
- 6013 mild penetration works well in all positions and needs a cleaner joint.
- 7018 mild penetration works well in all positions and works best on clean metals.
- 7024 mild penetration works well in the flat positions and needs a clean joint.

Setting up the Machine for SMAW

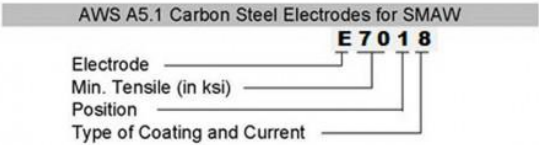
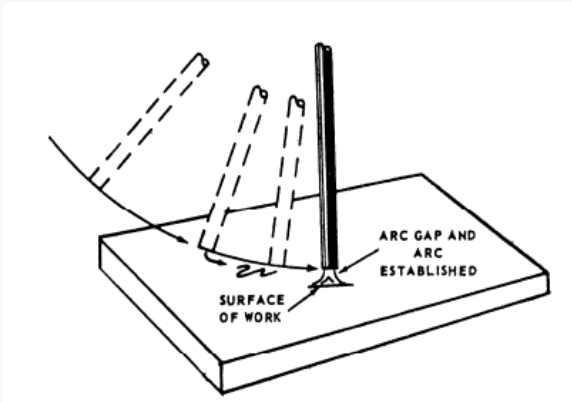
Steel Metal	Description																																																																								
 <p>Dial to show TIG/STICK switch</p>	<p>Swap to Electrode holder with cable and quick connect plug.</p> <p>Also press switch over to stick.</p> <p>Set the Polarity Switch for the type of electrode being used (most commonly DC+).</p>																																																																								
<table border="1" data-bbox="175 905 764 1310"> <thead> <tr> <th>Electrode</th> <th>Coating</th> <th>Position</th> <th>Current</th> <th>Penetration</th> <th>Tensile Strength</th> </tr> </thead> <tbody> <tr> <td>E-6010</td> <td>High Cellulose Sodium</td> <td>All Positions</td> <td>DCEP</td> <td>Deep</td> <td>60,000 PSI</td> </tr> <tr> <td>E-6011</td> <td>High Cellulose Potassium</td> <td>All Positions</td> <td>DCEP AC</td> <td>Deep</td> <td>60,000 PSI</td> </tr> <tr> <td>E-6012</td> <td>High Titania Sodium</td> <td>All Positions</td> <td>DCEP AC</td> <td>Medium</td> <td>60,000 PSI</td> </tr> <tr> <td>E-6013</td> <td>High Titania Potassium</td> <td>All Positions</td> <td>DCEP DCEN AC</td> <td>Shallow</td> <td>60,000 PSI</td> </tr> <tr> <td>E-7018</td> <td>Iron Powder Low hydrogen</td> <td>All Positions</td> <td>DCEP AC</td> <td>Shallow to Medium</td> <td>70,000 PSI</td> </tr> <tr> <td>E-7028</td> <td>Iron Powder Low hydrogen</td> <td>Flat Horizontal Fillets</td> <td>DCEP AC</td> <td>Shallow to Medium</td> <td>70,000 PSI</td> </tr> </tbody> </table> <p>Choose electrode and setting</p>	Electrode	Coating	Position	Current	Penetration	Tensile Strength	E-6010	High Cellulose Sodium	All Positions	DCEP	Deep	60,000 PSI	E-6011	High Cellulose Potassium	All Positions	DCEP AC	Deep	60,000 PSI	E-6012	High Titania Sodium	All Positions	DCEP AC	Medium	60,000 PSI	E-6013	High Titania Potassium	All Positions	DCEP DCEN AC	Shallow	60,000 PSI	E-7018	Iron Powder Low hydrogen	All Positions	DCEP AC	Shallow to Medium	70,000 PSI	E-7028	Iron Powder Low hydrogen	Flat Horizontal Fillets	DCEP AC	Shallow to Medium	70,000 PSI	<p>Choose an electrode. Below is an image explaining the coding of electrodes</p>  <table border="1" data-bbox="808 1157 1344 1402"> <thead> <tr> <th>Digit</th> <th>Type of Coating</th> <th>Current</th> </tr> </thead> <tbody> <tr> <td>0</td> <td>High Cellulose Sodium</td> <td>DC+</td> </tr> <tr> <td>1</td> <td>High Cellulose Potassium</td> <td>AC, DC±</td> </tr> <tr> <td>2</td> <td>High Titania Sodium</td> <td>AC, DC-</td> </tr> <tr> <td>3</td> <td>High Titania Potassium</td> <td>AC, DC±</td> </tr> <tr> <td>4</td> <td>Iron Power, Titania</td> <td>AC, DC±</td> </tr> <tr> <td>5</td> <td>Low Hydrogen Sodium</td> <td>DC+</td> </tr> <tr> <td>6</td> <td>Low Hydrogen Potassium</td> <td>AC, DC+</td> </tr> <tr> <td>7</td> <td>High Iron Oxide, Iron Powder</td> <td>AC, DC±</td> </tr> <tr> <td>8</td> <td>Low Hydrogen Potassium, Iron Powder</td> <td>AC, DC±</td> </tr> </tbody> </table>	Digit	Type of Coating	Current	0	High Cellulose Sodium	DC+	1	High Cellulose Potassium	AC, DC±	2	High Titania Sodium	AC, DC-	3	High Titania Potassium	AC, DC±	4	Iron Power, Titania	AC, DC±	5	Low Hydrogen Sodium	DC+	6	Low Hydrogen Potassium	AC, DC+	7	High Iron Oxide, Iron Powder	AC, DC±	8	Low Hydrogen Potassium, Iron Powder	AC, DC±
Electrode	Coating	Position	Current	Penetration	Tensile Strength																																																																				
E-6010	High Cellulose Sodium	All Positions	DCEP	Deep	60,000 PSI																																																																				
E-6011	High Cellulose Potassium	All Positions	DCEP AC	Deep	60,000 PSI																																																																				
E-6012	High Titania Sodium	All Positions	DCEP AC	Medium	60,000 PSI																																																																				
E-6013	High Titania Potassium	All Positions	DCEP DCEN AC	Shallow	60,000 PSI																																																																				
E-7018	Iron Powder Low hydrogen	All Positions	DCEP AC	Shallow to Medium	70,000 PSI																																																																				
E-7028	Iron Powder Low hydrogen	Flat Horizontal Fillets	DCEP AC	Shallow to Medium	70,000 PSI																																																																				
Digit	Type of Coating	Current																																																																							
0	High Cellulose Sodium	DC+																																																																							
1	High Cellulose Potassium	AC, DC±																																																																							
2	High Titania Sodium	AC, DC-																																																																							
3	High Titania Potassium	AC, DC±																																																																							
4	Iron Power, Titania	AC, DC±																																																																							
5	Low Hydrogen Sodium	DC+																																																																							
6	Low Hydrogen Potassium	AC, DC+																																																																							
7	High Iron Oxide, Iron Powder	AC, DC±																																																																							
8	Low Hydrogen Potassium, Iron Powder	AC, DC±																																																																							
 <p>Starting an arc</p>	<p>To start SMAW/Stick first, an arc has to be started. This can prove difficult and may often cause the rod to stick and the flux will likely chip off and ruin a small part of the rod. If that occurs then hold the rod about a 1/4" away from the metal till it melts to a complete and undamaged part of the rod.</p> <p>In stick welding, one should drag the rod.</p>																																																																								

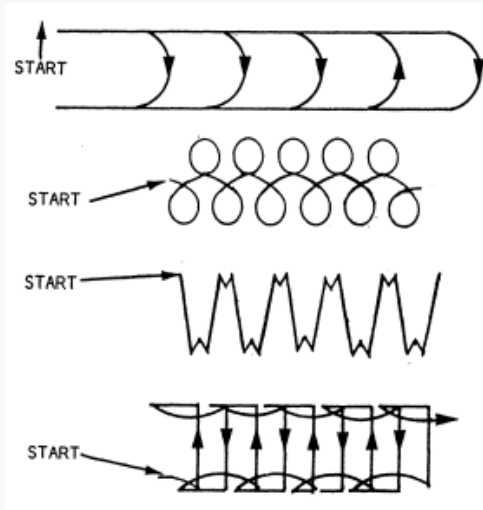

Weave motions

Most common techniques for SMAW are listed below and shown to the left:-

- Whipping the rod, a moving it back and forth motion.
- Circles to fuse the metal in a circular motion.
- Weaving a side to side motion (for wider welds).

Oxy Acetylene Welding and Cutting

- Oxy Acetylene can be used to weld metal and to cut metal.

Safety when using Oxy Acetylene

Oxyacetylene welding/cutting is not difficult, but there are a good number of subtle safety points that should be learned such as:

- More than 1/7 the capacity of the cylinder should not be used per hour. This causes the acetone inside the acetylene cylinder to come out of the cylinder and contaminate the hose and possibly the torch.
- Acetylene is dangerous above 1 atm (15 psi) pressure. It is unstable and explosively decomposes.
- Proper ventilation when welding will help to avoid large chemical exposure.
- Proper eye protection such as [welding goggles](#) should be worn at all times
- When using fuel and oxygen tanks they should be fastened securely upright to a wall or a post or a portable cart.

Difference between Cutting and Welding

- A welding head is simple, and has two valves located near the base of the head
- For cutting, there is a different head. It has three tubes going up to the nozzle. And has an oxygen blast trigger

Pictures Illustrate Parts referred to in the steps

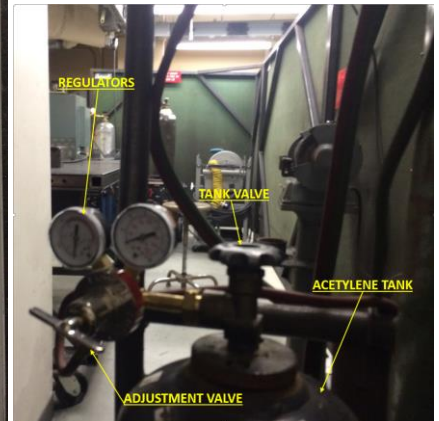
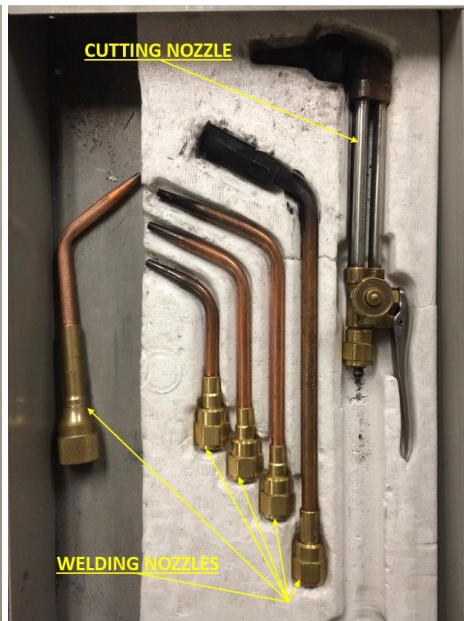
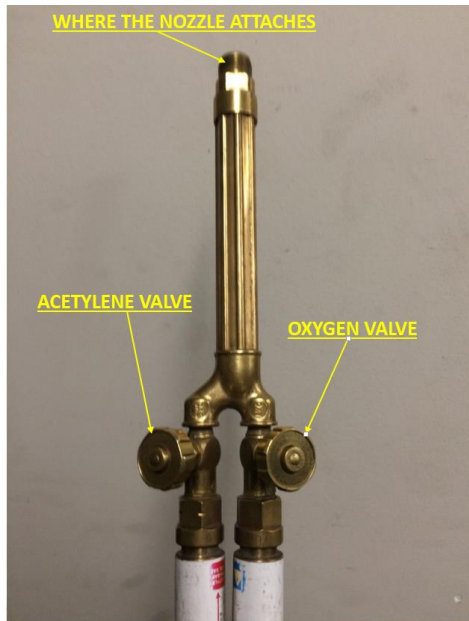
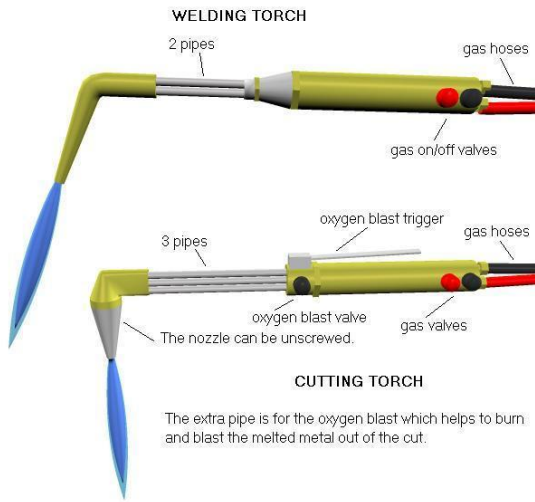

Setting up Oxy Acetylene for Welding

Step	Description
1. Clean Nozzle	Clean the nozzle on the head. This should be done with a fine, round metal file. Just make sure that this nozzle hole is unobstructed. If holes are obstructed, a torch tip bore cleaning tool may be necessary
2. Fasten Head to hose	Securely fasten the "head" of the torch on the end of the hoses. It should thread into a socket where both the Oxygen and Acetylene hoses come together. Usually this joint is brass.

<p>3. Tighten "head" valves</p>	<p>Tighten both valves on the "head" that you just secured in the socket. Make sure these valves are shut completely; otherwise, your gas/air mixtures will be off.</p>
<p>4. Turn on tank valves</p>	<p>Turn on your valves on the tanks. Acetylene main valve should only be opened 1/2 turn, and the regulator set at 5 to 7 psi (pounds per square inch). (If acetylene is turned up too high, it can become unstable.) For welding, the oxygen should be set between 7 and 10 psi. For cutting, the oxygen should be set between 15 and 25 PSI.</p>
<p>5. Turn on Acetylene</p>	<p>Turn on the Acetylene valve until you hear a slight hiss of gas from the nozzle.</p>
<p>6. Light Torch</p>	<p>Take your striker/lighter and light the torch. This should produce a dark red-orange flame which puts out very putrid black smoke.</p>
<p>7. Adjust Flame</p>	<p>Slowly turn on the valve that controls your oxygen, until you see the flame change. The flame should be blue with a white inside tip. The inner, white tip should measure around $\frac{3}{8}$ inch (1.0 cm) long. Careful: too much oxygen and you can "bleed out" the flame -- which means the flame will go out. In this event, turn the oxygen off and try again.</p>
<p>8. Weld</p>	<p>The flame is applied to the base metal and held until a small puddle of molten metal is formed. The puddle is moved along the path where the weld bead is desired. Usually, more metal is added to the puddle as it is moved along by dipping metal from a welding rod or filler rod into the molten metal puddle. The metal puddle will travel towards where the metal is the hottest. This is accomplished through torch manipulation by the welder.</p>

Setting up Oxy Acetylene for Cutting

Step	Description
<p>Steps 1-4</p>	<p>Turn the oxygen that IS released by the trigger, all the way on.</p>
<p>5. Oxygen blast trigger</p>	<p>Turn on the Acetylene valve until you hear a slight hiss of gas from the nozzle.</p>

<p>6. Turn on Acetylene</p>	<p>Turn on the Acetylene valve until you hear a slight hiss of gas from the nozzle</p>
<p>7. Light the torch</p>	<p>Take your striker/lighter and light the torch. This should produce a dark red/orange flame, that puts out very putrid black smoke.</p>
<p>8. Adjust Flame</p>	<p>Slowly turn on the valve that controls your oxygen (there are two valves for oxygen on a cutting head, one blocked controlled by the trigger, one unrestricted), until you see the flame change. Careful: too much oxygen and you can "bleed out" the flame -- which means the flame will go out. In this event, turn the oxygen off and try again. The flame, when the trigger is NOT compressed, should be a blue flame, measuring about two inches, with about a 1/2" bluish-yellow inner flame. When the trigger is compressed, the flame will become much shorter, louder, and faster</p>
<p>9. Cut</p>	<p>When cutting, always heat the metal up to a nice cherry red, and then press the trigger for oxygen. Caution: Sparks will be thrown, so be aware and safe</p>

Shutting Down Oxy Acetylene

<p>Step</p>	<p>Description</p>
<p>1. Close Oxygen Head valve</p>	<p>Turn the oxygen that IS released by the trigger, all the way on.</p>
<p>2. Close Acetylene Head valve</p>	<p>Turn on the Acetylene valve until you hear a slight hiss of gas from the nozzle.</p>
<p>3. Close tank valves</p>	<p>Close oxygen and acetylene tank valves</p>
<p>4. Purge Lines</p>	<p>Separately purge oxygen and acetylene lines</p>
<p>8. Check Regulators</p>	<p>Make sure regulators read 0</p>
<p>9. Pressure adjustment</p>	<p>Back out regulator pressure adjustment screw</p>
<p>10. Inspect</p>	<p>Report any damage to the shop manager</p>

