

Lecture 10

HYDRAULIC MOTORS

Learning Objectives

Upon completion of this chapter, the student should be able to:

- Differentiate between a hydraulic motor and a hydraulic pump.
- List various applications of hydraulic motor in fluid power.
- Discuss various classifications of hydraulic motor.
- Explain the construction and working of gear, vane and piston motors.
- Discuss the various types of limited-rotation motors.
- Explain various types of efficiency terms used in hydraulic motors.
- Evaluate the performance parameters of systems using motors.

1.1 Introduction

Hydraulic motors are rotary actuators. However, the name rotary actuator is reserved for a particular type of unit that is limited in rotation to less than 360° . A hydraulic motor is a device which converts fluid power into rotary power or converts fluid pressure into torque. Torque is a function of pressure or, in other words, the motor input pressure level is determined by the resisting torque at the output shaft. A hydraulic pump is a device which converts mechanical force and motion into fluid power. A hydraulic motor is not a hydraulic pump when run backward. A design that is completely acceptable as a motor may operate very poorly as a pump in a certain applications. Differences between a hydraulic motor and a hydraulic pump are given in Table 1.1.

Table 1.1 Differences between a hydraulic motor and a hydraulic pump

Hydraulic Motor	Hydraulic Pump
It is a device for delivering torque at a given pressure. The main emphasis is on mechanical efficiency and torque that can be transmitted.	It is a device for delivering flow at a given pressure. The main emphasis is on volumetric efficiency and flow.
Motors usually operate over a wide range of speed, from a low RPM to high RPM.	Pumps usually operate at high RPM.
Most motors are designed for bidirectional applications such as braking loads, rotary tables.	In most situations, pumps usually operate in one direction.
Motors may be idle for long time (as in index table).	Pumps usually operate continuously.
Motors are subjected to high side loads (from gears, chains, belt-driven pulleys).	Majority of pumps are not subjected to side loads. Usually pumps are pad mounted on power pack top and shaft is connected to the prime mover directly.

1.2 Applications

Hydraulic motors have become popular in industries. Hydraulic motors can be applied directly to the work. They provide excellent control for acceleration, operating speed, deceleration, smooth reversals and positioning. They also provide flexibility in design and eliminate much of bulk and weight of mechanical and electrical power transmission. The applications of hydraulic motors in their various combinations with pumping units are termed hydrostatic transmission.

A hydrostatic transmission converts mechanical power into fluid power and then reconverts fluid power into shaft power. The advantages of hydrostatic transmissions include power transmission to remote areas, infinitely variable speed control, self-overload protection, reverse rotation capability, dynamic braking and a high power-to-weight ratio. Applications include material-handling equipment, farm tractors, railway locomotives, buses, lawn mowers and machine tools.

New fields of applications are being discovered constantly for hydrostatic transmissions. Farm implements, road machinery, material-handling equipment, Numerical Control (NC) machines, high-performance aircrafts, military uses and special machinery are only a few of new fields expanding through the use of fluid power transmission. Many automobiles, railway locomotives and buses use a hydrostatic transmission.

1.3 Comparison Between a Hydraulic Motor and an Electric Motor

Table 1.2 gives the comparison between a hydraulic motor and an electric motor.

Table 1.2 Comparison between a hydraulic motor and an electric motor

Electric Motor	Hydraulic Motor
Electric motors cannot be stopped instantly. Their direction of rotation cannot be reversed instantly. This is because of air gap between the rotor and stator and the weak magnetic field.	Hydraulic motors can be stalled for any length of time. Their direction of rotation can be instantly reversed and their rotational speed can be infinitely varied without affecting their torque. They can be braked instantly and have immense torque capacities.
Electric motors are heavy and bulky.	Hydraulic motors are very compact compared to electric motors. For the same power, they occupy about 25% of the space required by electric motors and weigh about 10% of electric motors.
Moment of inertia-to-torque ratio is nearly 100.	Moment of inertia-to-torque ratio is nearly 1.

1.4 Classification of Hydraulic Motors

There are two types of hydraulic motors: (a) High-speed low-torque motors and (b) low-speed high-torque motors. In high-speed low-torque motors, the shaft is driven directly from either the barrel or the cam plate, whereas in low-speed high-torque motors, the shaft is driven through a differential gear arrangement that reduces the speed and increases the torque. Depending upon the mechanism employed to provide shaft rotation, hydraulic motors can be classified as follows:

1. Gear motors.
2. Vane motors.
3. Piston motors:
 - Axial piston-type motors.
 - Radial piston-type motors.

Gear motors are the least efficient, most dirt-tolerant and have the lowest pressure rating of 3. Piston motors are the most efficient, least dirt-tolerant and have high pressure ratings. Vane and piston motors can be fixed or variable displacement, but gear motors are available with only fixed displacement.

1.5 Gear Motors: A gear motor develops torque due to hydraulic pressure acting against the area of one tooth. There are two teeth trying to move the rotor in the proper direction, while one net tooth at the center mesh tries to move it in the opposite direction. In the design of a gear motor, one of the gears is keyed to an output shaft, while the other is simply an idler gear. Pressurized oil is sent to the inlet port of the motor. Pressure is then applied to the gear teeth, causing the gears and output shaft to rotate. The pressure builds

until enough torque is generated to rotate the output shaft against the load. The side load on the motor bearing is quite high, because all the hydraulic pressure is on one side. This limits the bearing life of the motor. Schematic diagram of gear motor is shown in Fig.1.1.

Most of the gear motors are bidirectional. Reversing the direction of flow can reverse the direction of rotation. As in the case of gear pumps, volumetric displacement is fixed. Due to the high pressure at the inlet and low pressure at the outlet, a large side load on the shaft and bearings is produced. Gear motors are normally limited to 150 bar operating pressures and 2500 RPM operating speed. They are available with a maximum flow capacity of 600 LPM. The gear motors are simple in construction and have good dirt tolerance, but their efficiencies are lower than those of vane or piston pumps and they leak more than the piston units. Generally, they are not used as servo motors. Hydraulic motors can also be of internal gear design. These types can operate at higher pressures and speeds and also have greater displacements than external gear motors.

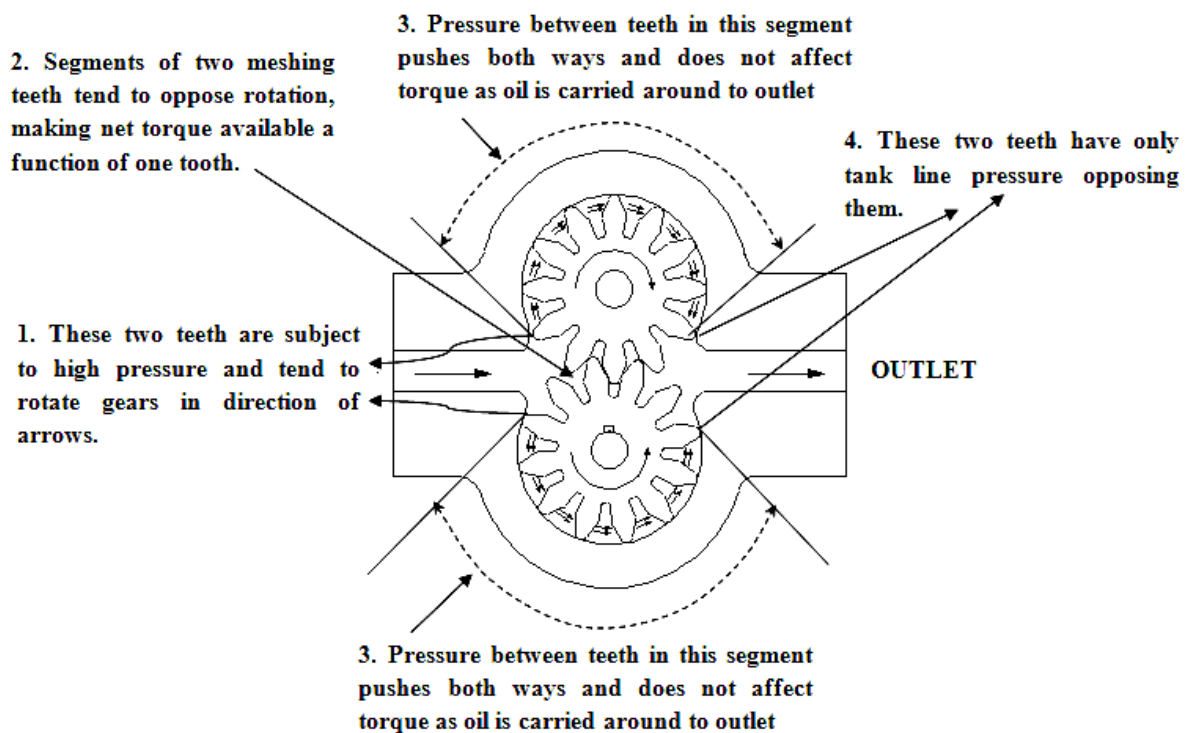

Figure 1.1 Gear motor

1.6 Vane Motors

Figure 1.2 shows an unbalanced vane motor consisting of a circular chamber in which there is an eccentric rotor carrying several spring or pressure-loaded vanes. Because the fluid flowing through the inlet port finds more area of vanes exposed in the upper half of the motor, it exerts more force on the upper vanes, and the rotor turns counterclockwise. Close tolerances are maintained between the vanes and ring to provide high efficiencies.

The displacement of a vane hydraulic motor is a function of eccentricity. The radial load on the shaft bearing of an unbalanced vane motor is also large because all its inlet pressure is on one side of the rotor.

Figure 1.3 shows the balanced vane motor. The radial bearing load problem is eliminated in this design by using a double-lobed ring with diametrically opposite ports. Side force on one side of bearing is canceled by an equal and opposite force from the diametrically opposite pressure port. The like ports are generally connected internally so that only one inlet and one outlet port are brought outside. The balanced vane-type motor is reliable open-loop control motor but has more internal leakage than piston-type and therefore generally not used as a servo motor.

1.7 Piston Motors

Piston motors are classified into the following types:

1. According to the piston of the cylinder block and the drive shaft, piston motors are classified as follows:
 - Axial piston motors.
 - Radial piston motors.
2. According to the basis of displacement, piston motors are classified as follows:
 - Fixed-displacement piston motors.
 - Variable-displacement piston motors.

1.7.1 Axial Piston Motors

In axial piston motors, the piston reciprocates parallel to the axis of the cylinder block. These motors are available with both fixed-and variable-displacement feature types. They generate torque by pressure acting on the ends of pistons reciprocating inside a cylinder block. Figure 1.4 illustrates the inline design in which the motor, drive shaft and cylinder block are centered on the same axis. Pressure acting on the ends of the piston generates a force against an angled swash plate. This causes the cylinder block to rotate with a torque that is proportional to the area of the pistons. The torque is also a function of the swash-plate angle. The inline piston motor is designed either as a fixed- or a variable-displacement unit. The swash plate determines the volumetric displacement. Refer Fig.1.5.

Figure 1.4 Inline piston motor

In variable-displacement units, the swash plate is mounted on the swinging yoke. The angle can be varied by various means such as a lever, hand wheel or servo control. If the offset angle is increased, the

displacement and torque capacity increase but the speed of the drive shaft decreases. Conversely, reducing the angle reduces the torque capability but increases the drive shaft speed.

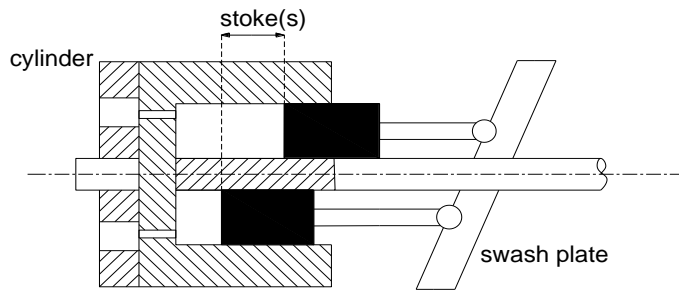

Figure1.5Swash-plate piston motor

1.7.2 Bent-Axis Piston Motors

A bent-axis piston motor is shown in Fig.1.6. This type of motor develops torque due to pressure acting on the reciprocating piston. In this motor, the cylinder block and drive shaft mount at an angle to each other so that the force is exerted on the drive shaft flange.

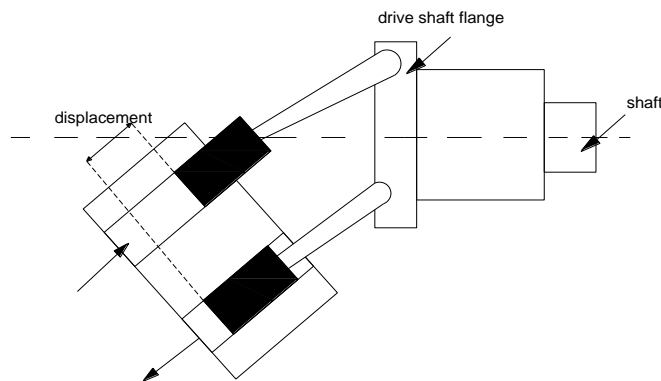

Figure1.6Inline piston motor

Speed and torque depend on the angle between the cylinder block and the drive shaft. The larger the angle, the greater the displacement and torque, and the smaller the speed. This angle varies from 7.5° (minimum) to 30° (maximum). This type of motor is available in two types, namely fixed-displacement type and variable-displacement type. Refer Fig.1.7

7.3 Radial Piston Motors

In radial piston-type motors, the piston reciprocates radially or perpendicular to the axis of the output shaft. The basic principle of operation of the radial piston motors is shown in Fig.1.8. Radial piston motors are low-speed high-torque motors which can address a multifarious problem in diverse power transfer applications.

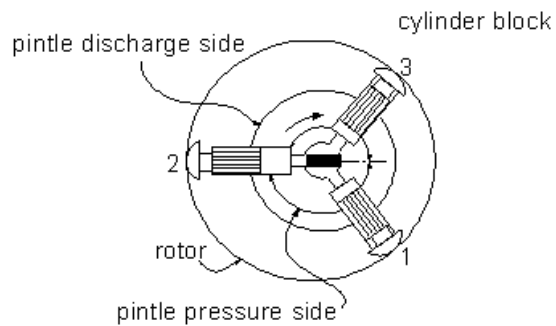

Figure 1.8 Radial piston motor

1.8 Semi-Rotary Actuators

These are devices used to convert fluid energy into a torque which turns through an angle limited by the design of the actuator. With the majority of designs, the angle of rotation is limited to 360° although it is possible to considerably exceed this when using piston-operated actuators.

1.8.1 Vane-Type Semi-Rotary Actuator (Single Vane)

A single-vane rotary actuator is shown in Fig. 1.9. A semi-rotary actuator allows only a partial revolution. A vane-type semi-rotary actuator consists of a vane connected to an output shaft. When hydraulic pressure is applied to one side of the vane, it rotates. A stop prevents the vane from rotating continuously. The rotation angle in the case of a single-vane semi-rotary actuator is 315° .

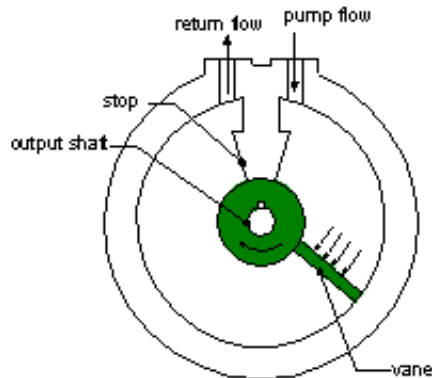

Figure 1.9 Vane-type semi-rotary

1.8.2 Two-Vane-Type Semi-Rotary Actuator

A two-vane rotary actuator is shown in Fig. 1.10. The advantage of this design is that the torque output is increased because the area subjected to pressure is large. However, two-vane models cannot rotate as many degrees as can single-vane models. It is limited to 100° . Passageways are used to connect the different chambers of the rotary actuator.

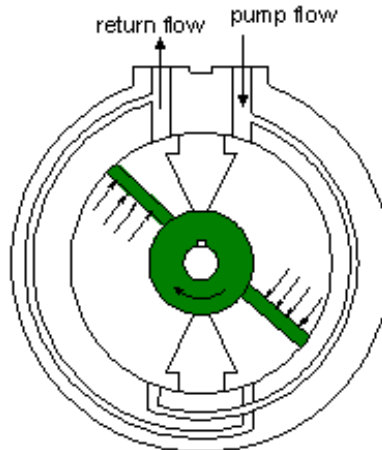

Figure 1.10 Two-vane type

1.8.3 Analysis of a Semi-Rotary Single-Vane Motor

Let

R_R = Outer radius of the output shaft (m)

R_V = Outer radius of the vane (m)

L = Width of the vane (m)

p = Hydraulic pressure (Pa)

F = Hydraulic force acting on the vane (N)

A = Surface area of vane in contact with oil (m²)

T = Torque capacity (N m)

The force on the vane equals the pressure times the vane surface area:

$$F = pA = p(R_V - R_R)L$$

The torque equals the vane force times the mean radius of the vane:

$$T = p(R_V - R_R)L \frac{R_V + R_R}{2}$$

On rearranging, we have

$$T = p(R_V^2 - R_R^2)L \quad (1.1)$$

A second equation for torque can be developed by noting the following relationship for volumetric displacement V_D :

$$V_D = \pi(R_V^2 - R_R^2)L \quad (1.2)$$

Combining Equations. (1.1) and (1.2) yields

$$T = \frac{p \times V_D}{2\pi}$$

Example 1.1A single-vane rotary actuator has the following physical data:

Outer radius of rotor = 0.5 cm

Outer radius of vane = 1.5 cm

Width of vane = 1 cm

If the torque load is 1000 Ncm, what pressure must be developed to overcome the load?

Solution: The volumetric displacement is given by

$$V_D = \pi(1.5^2 - 0.5^2)1 = 6.28 \text{ cm}^3$$

The pressure is

$$p = \frac{2\pi T}{V_D} = \frac{2\pi(1000)}{6.28} = 1000 \text{ N/cm}^2$$

$$= 1000 \times 10^4 \text{ N/m}^2$$

$$= 10 \text{ N/mm}^2 = 10 \text{ MPa}$$

1.9 Chain and Sprocket Semi-Rotary Actuator

In this design (Fig. 1.11), an endless chain and a sprocket are used. It is suitable for multi-revolution applications. The chain is anchored to two pistons, one large and other small, which when in their respective bores separate the half of the unit. The larger cylinder is the power cylinder and the smaller cylinder is the chain return or seal cylinder. The idler is automatically a tensioned one, so that a constant tension is maintained. Pressure is applied to one port of the actuator. The larger piston moves away from the port due to differential areas of the two pistons. The movement of larger piston pulls the chain, causing the sprocket and output shaft to rotate.

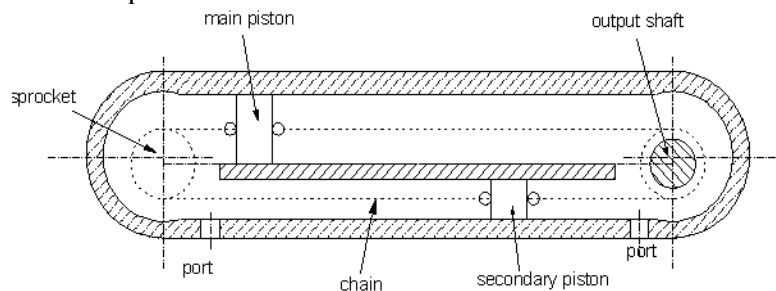

Figure 1.11 Chain and sprocket

1.10 Rack and Pinion Rotary Actuator

A rack and pinion rotary actuator (Fig. 1.12) is a commonly used design for obtaining partial revolution actuation. This consists of a hydraulic cylinder with a rack and pinion gear mechanism. The rack gear on the piston rod turns the pinion gear, thereby converting the linear motion of the piston into rotary motion, which is transmitted to the load through the output shaft.

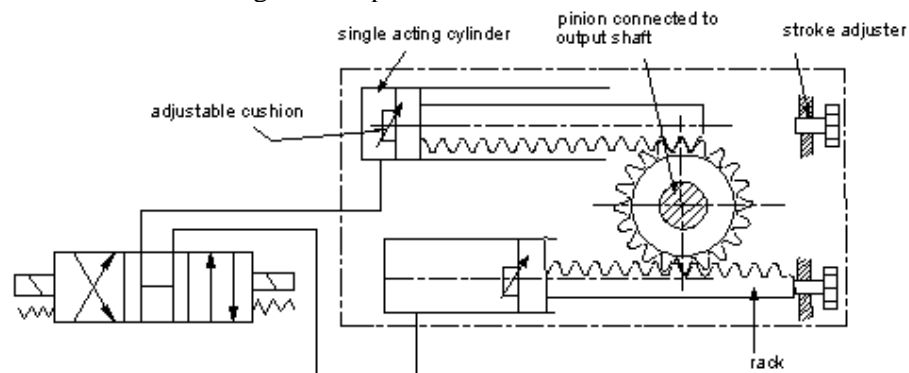

Figure 1.12 Rack and rotary actuator

Another design of a rack and pinion semi-rotary actuator is shown in Fig.1.13. In this design, the cylinder drives a pinion gear and the rack is an integral part of the piston rod. The angle of rotation depends upon the stroke of the cylinder, rack and the pitch circle diameter of the pinion. The start and finish of the stroke are adjusted by means of an internal stop(stroke adjuster).

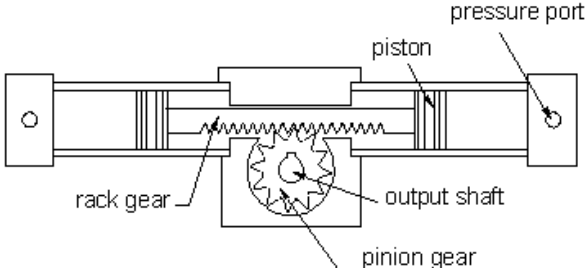

Figure 1.13Rack and rotary actuator

1.11Hydraulic Motor:Theoretical Torque, Power and Flow Rate

The torque generated by a frictionless hydraulic motor is known as a theoretical torque. Theoretical torque can be calculated by the following formula:

$$T_T = \frac{p \times V_D}{2\pi}$$

where V_D is the volumetric displacement in m^3/rev and p is the pressure in N/m^2 . The power developed by a frictionless motor is known as theoretical power. It can be calculated by the following formula:

$$P_T = T_T \times \omega$$

(W) = (Nm) rad/s = W

where T_T is the theoretical torque in Nm, ω is the speed of the motor in rad/s and $\omega = 2\pi N / 60$, where N is the speed of the motor in rev/min. The flow rate a hydraulic motor would consume if there were no leakage is known as the theoretical flow rate Q_T . Mathematically, theoretical flow rate is given by

$$Q_T = V_D n$$

where V_D is the volumetric discharge in m^3/rev , n is the speed of motor in rev/s = $N/60$ and N is the speed of motor in rpm.