

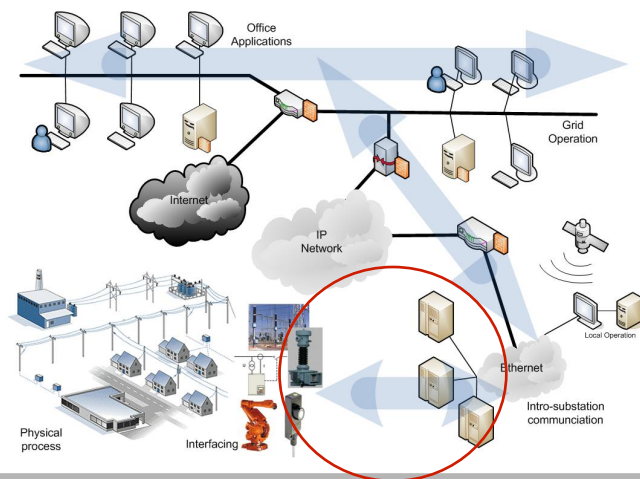

Lecture 4 Power System Protection

Course map



Outline of the Lecture



- Control vs Protection
- Protection Principles
- Protection requirements
- Protection Schemes

3

Control vs. Protection



Control functions

Optimization of operation

Minimization of losses
Economical optimization

Protection functions

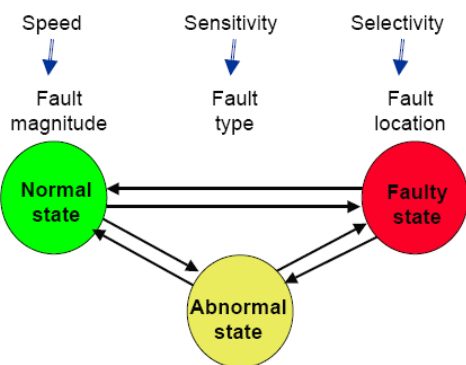

4



Why do we need to control?

- Control actions needed
- Automatic
 - Equipment Protection
 - Disconnection at fault
 - Voltage control
 - Move a tapchanger in a transformer
- Human intervention
 - Frequency control
 - Increase output in hydro plant
 - Voltage control
 - Connect capacitor bank

5



What can we control?

- Breakers
- Valves
- Tap changers
- Switches
- Drives
-

All done using Relays

6



Basic Relay concepts

- Electromechanical Pre 1970s
- Static 1970s
- Digital 1980s
- "Numerical" Present ->

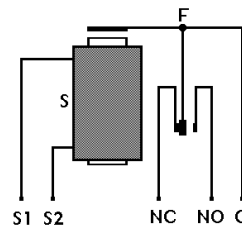
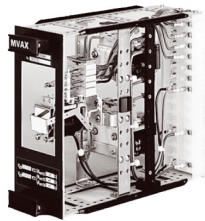

The numerical relay

- Current state of the practice
 - A/D & D/A converters
 - Dedicated CPU for Digital Signal Processing
 - Programmable
 - Real-time operating system





Application examples

Distance Protection - several schemes including user definable)
Overcurrent Protection (directional/non-directional)
Several Setting Groups for protection values
Switch-on-to-Fault Protection
Power Swing Blocking
Voltage Transformer Supervision
Negative Sequence Current Protection
Undervoltage Protection
Overvoltage Protection
CB Fail Protection
Fault Location
CT Supervision
VT Supervision
Check Synchronisation
Autoreclose
CB Condition Monitoring
CB State Monitoring
User-Definable Logic
Broken Conductor Detection
Measurement of Power System Quantities (Current, Voltage, etc.)
Fault/Event/Disturbance recorder

9



Numerical relays - issues

- Software Version Control
 - Same problem as for all software systems
- Relay Data Management
 - Large amounts of parameters
 - Vendors specific vs. standardisation
- Testing & Commissioning
 - Complex equipment needed for testing
 - Too complex for field repairs

10

Outline of the Lecture



- Control vs Protection
- Protection Principles
- Protection requirements
- Protection Schemes

11

Purpose of the Protection System

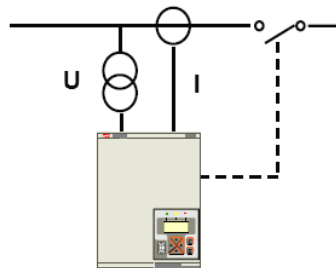

- Protect Equipment
- Protect People & Property
- Separate Faulty section from power system
- Restore normal operation

12

Most basic type of protection?

- The Fuse

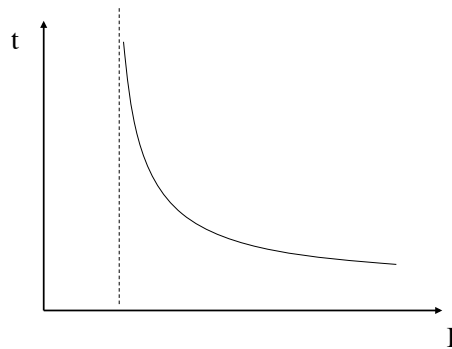

13

Relay Protection system

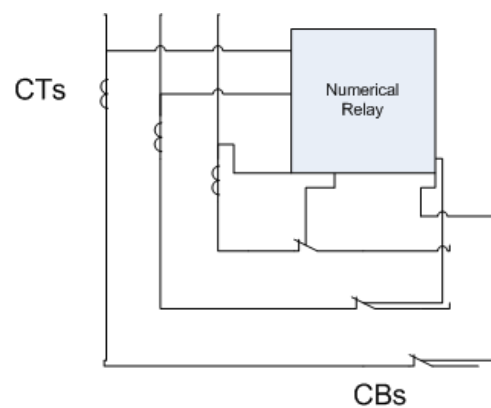

14



Different Types of Protection

By object

- Line protection
- Feeder protection
- Transformer protection
- Generator protection
- Busbar protection
- Motor protection
- etc

By principle

- Distance protection
 - Impedance protection
- Differential protection
 - Pilot wire protection
- Overcurrent protection
- Residual current protection
 - Directional earth fault
- Over/under frequency protection
- Over/under voltage protection
- etc

15



Assets in a Power Grid (value)

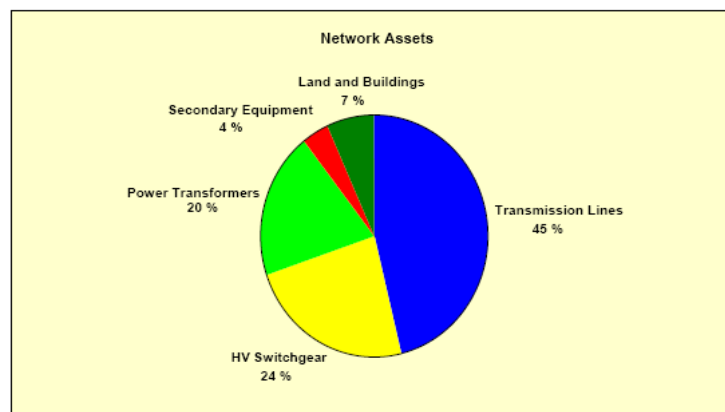

16

Fault types

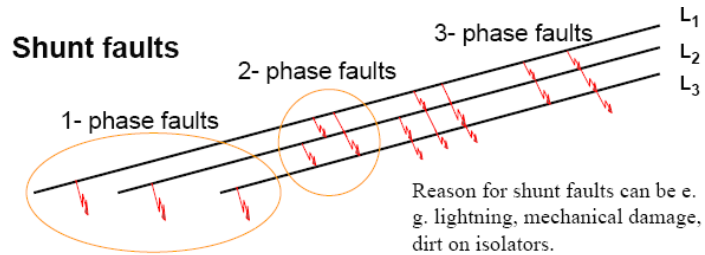

Serial faults

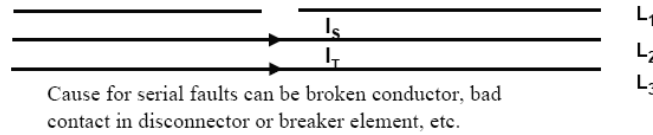

17

Fault Statistics



Transmission systems	• Transmission lines	85 %
	• Busbars	12 %
	• Generators / transformers	3 %
Transmission lines Type of fault	• Single phase to ground	80 %
	• Two phases to ground	10 %
	• Two phase	5 %
	• Three phase	5 %
Faults per 100 units/year	• Hydro turbine	6.2
	• Hydro generator	14.6
	• Transformer	2-3
	• Breaker	1
	• CT & VT	0.2

18

Line fault statistics



Voltage	Faults per 100 km / year
400 kV	0.2 – 1.0
220 kV	0.7 – 3.5
130 kV	3 – 15
70 kV	2 – 10
40 kV	6 – 30
20 kV	18 – 90

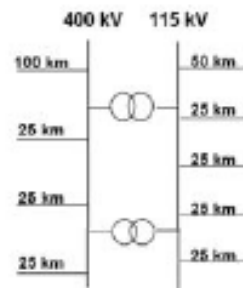

300 km 400 kV line: 0.6 - 3 fault / year
10 km 40 kV line: 0.6 - 3 fault / year

5 - 25 faults/ year

19

Outline of the Lecture



- Control vs Protection
- Protection Principles
- Protection requirements
- Protection Schemes

20



Protection requirements

- The protection system must be
 - Reliable
 - Stable
 - Sensitive
 - Selective
 - Timely

21



Reliability

- The protection system **must** provide its function when required to avoid damage to equipment, people or property
- Reliability problems stem from
 - Incorrect design
 - Incorrect installation/testing
 - Deterioration
- The study of the reliability of a protection system is critical

22

Stability



- The protection system shall not react to non-fault situations
- The protection system must not react to faults in neighboring zones or high load currents.

23

Sensitivity



- Sensitivity refers to the minimal changes in measured parameter that the system can react to.
- For electromagnetic relays, this was a main design characteristic.
- Presently, the sensitivity is determined by the CT/VT and design of the system

24

Selectivity



- Only the effected parts of the power system shall be disconnected.
- Is achieved by two main methods
 - Time-grading/Current Grading
 - Relays are set to operate depending on the time and current characteristics
 - Unit systems
 - Current is measured at several points and compared.

25

Timeliness - Speed



- Faults must be isolated as fast as possible.
- Speed is necessary for two main reasons
 - Maintain stability of the overall power system
 - Reduction of damage to equipment & property

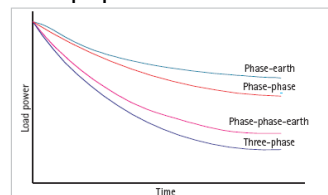
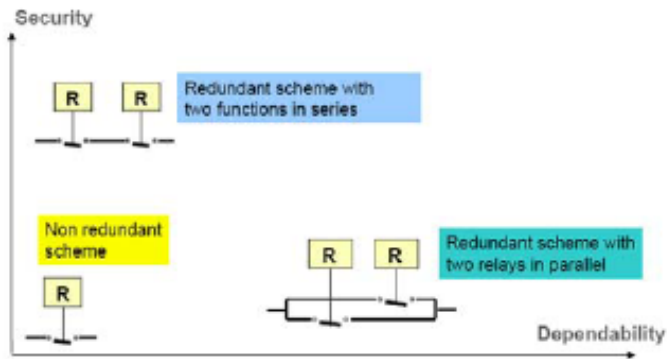

Figure 2.8: Typical power/time relationship for various fault types

26



Stability vs Reliability



27



Fault Clearance Chain

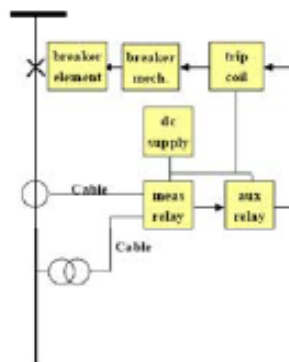

The fault clearance chain consists of many elements all of equal importance.

To secure fault clearance protection system must include back-up protection.

Back-up protection can be of type:

- Remote back-up
- Local back-up

A common requirement, world-wide, on the protection system is that fault clearance shall be secured also with a single-failure in the fault clearance chain. This is called "the single-failure criteria" and is the lead star at designing the protection system.

28

FCC with Local backup

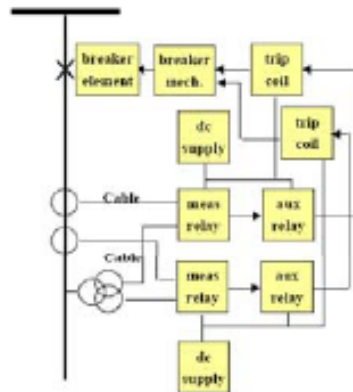

Local back-up must be used when remote back-up cannot be arranged. This is mostly the case on the transmission level.

The local back-up includes two protection relays, covering the same primary fault, operating on the same circuit breaker.

When the protection relays are of equal type, the protection system is said to include "redundant protection".

The circuit breaker and the CT and VT are not duplicated of cost reason. However, two trip coils, two CT cores, two VT secondary cores or fuse groups etc are provided to achieve high dependability.

Breaker Failure Protection

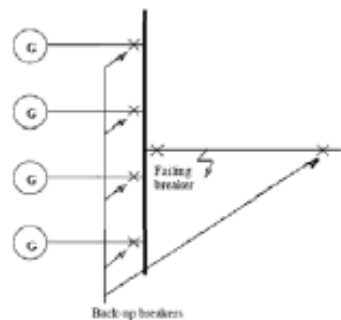

Breaker failure protection (BFP):

Breaker failure function is the Local back-up for breaker failures.

The breaker failures can be due to trip coil, breaker drive or breaking components failure.

At a breaker failure the surrounding breakers are used to clear the fault.

Due to the big impact a breaker failure trip will have on the power system service, the BFP function has very high requirements on security against unnecessary tripping.

The BFP function is started at CB tripping and if current still flows within, about 150 ms the surrounding breakers are tripped.



Outline of the Lecture

- Control vs Protection
- Protection Principles
- Protection requirements
- Protection Schemes

31



Different Types of Protection

By object

- Line protection
- Feeder protection
- Transformer protection
- Generator protection
- Busbar protection
- Motor protection
- etc

By principle

- Distance protection
 - Impedance protection
- Differential protection
 - Pilot wire protection
- Overcurrent protection
- Residual current protection
 - Directional earth fault
- Over/under frequency protection
- Over/under voltage protection
- etc

32



Fundamentals of Protection

- Protection System
 - A complete arrangement of equipment that fulfills the protection requirements
- Protection Equipment
 - A collection of devices excluding CT, CB etc
- Protection Scheme
 - A collection of protection equipment providing a defined function.

33



Zones of Protection

- By dividing the power system into protection zones the extent of disconnections can be limited

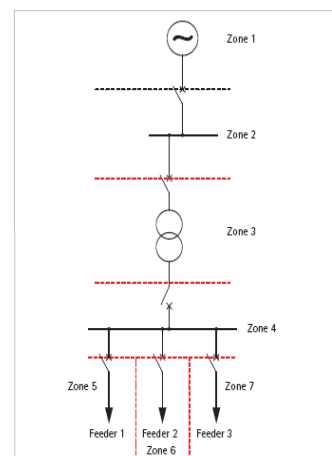

34

Overlapping protection zones

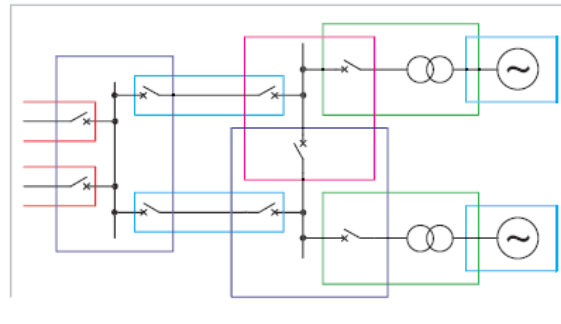
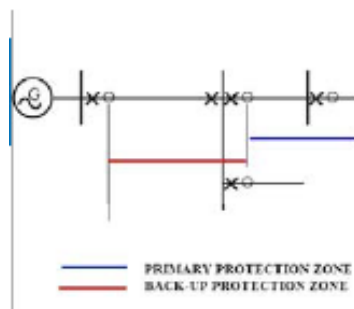

Figure 2.7: Overlapping zones of protection systems

Backup Protection Zones



The protection zones are decided by the location of current transformers. Normally the CT is located close to the circuit breaker to have measuring zone and breaking point close-up.

Back-up protection can be remote, as on figure, or local where primary and back-up zones starts at same CT and operates on same CB.

Remote back-up is the common principle on distribution voltage levels whereas local back-up is used on transmission voltage levels.

Over-Current Protection



- Simplest form next to the fuse
- Use extensively in Distribution networks

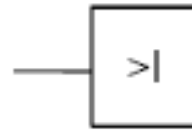

37

Achieving Selectivity



38



Discrimination by Time

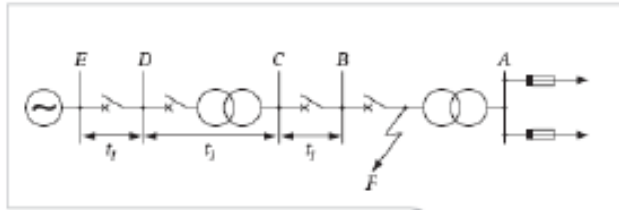
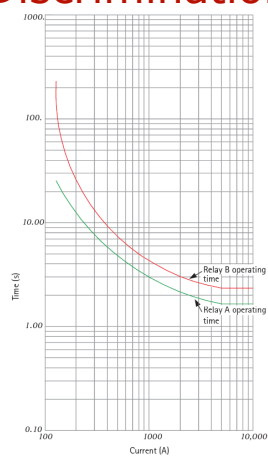

Figure 9.1: Radial system with time discrimination

DTOC
Definite Time Over Current



Discrimination by Time & Current



Relay A: Current Setting = 100A, TMS = 1.0
Relay B: Current Setting = 125A, TMS = 1.3

Figure 9.3: Relay characteristics for different settings



Directional Relays

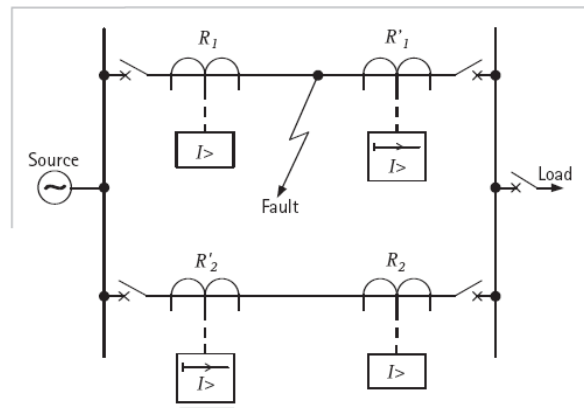

Figure 9.13: Directional relays applied to parallel feeders

41



Time grading

- Example from Strauss 4.4.2.

42



Example - Protection Scheme

From Utility Transmission Network

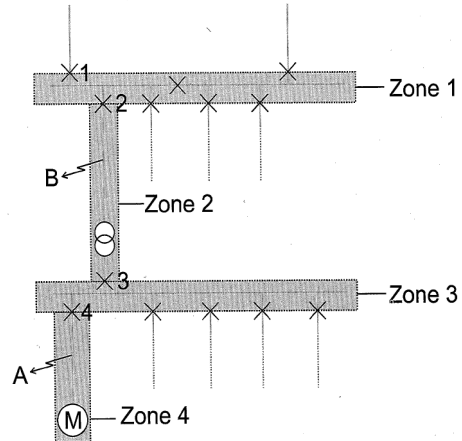

MARIUS EKSTED

43



Example - relay settings

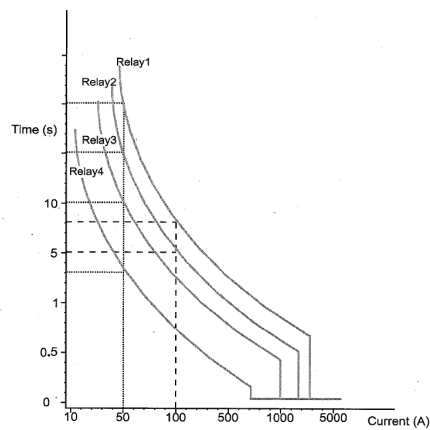

MARIUS EKSTED

44



Distance Protection

- Dual input V & I
- Based on ratio Z

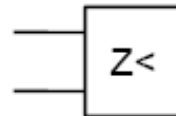

Principle of Distance Protection

Principle of Distance Protection

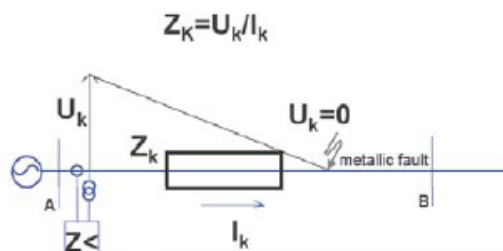

The impedance is proportional to the distance!



Power Line Characteristics

Power lines have impedances of size 0,3- 0,4 ohm/ km and normal angles of 80 - 85 degrees in a 50Hz systems.

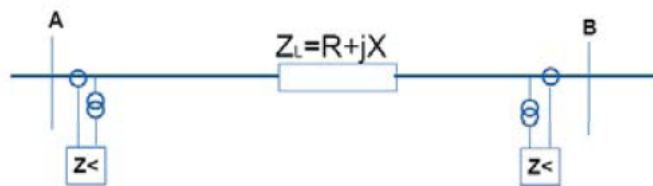

47



Benefits of Distance Protection

- Local current and voltage: No need for communication
- Fault on protected line: Reach independent of fault current level
- Enables remote back-up protection.

48



Differential Protection

- Dual input
- At each end of protected device

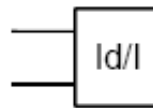

Unit – Differential Protection

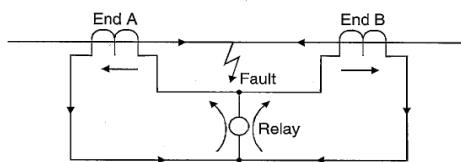
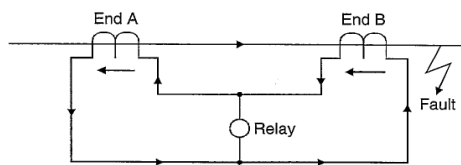



Different Protection schemes

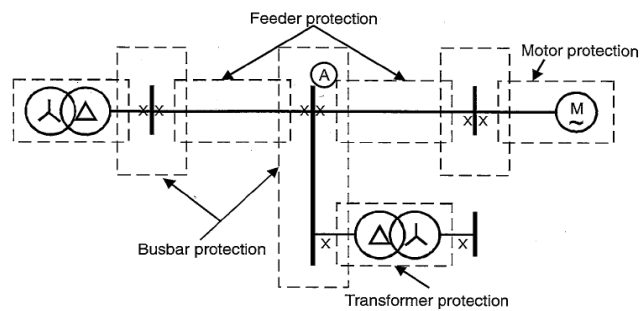

51



Protection Summary

- The Power System must be protected
 - To avoid damage to equipment, people & property
- Protection systems are created using CT/VTs, relays and circuit breakers
- Key characteristics are:
 - Selectivity
 - Speed
 - Reliability
 - Stability
 - Sensitivity
- Numerical Relays are essentially small computers - The Intelligent Electronic Device

52