

LECTURE NOTES ON FOUNDATION ENGINEERING

Department of Civil Engineering



INSTITUTE OF AERONAUTICAL ENGINEERING

Dundigal – 500 043, Hyderabad

SKYUP'S MEDIA

FOUNDATION ENGINEERING

OBJECTIVE

At the end of this course student acquires the capacity to assess the soil Condition at a given location in order to suggest suitable foundation and also gains The knowledge to design various foundations.

UNIT I

SITE INVESTIGATION AND SELECTION OF FOUNDATION

Scope and objectives – Methods of exploration-auguring and boring – Water boring and rotatory drilling – Depth of boring – Spacing of bore hole - Sampling – Representative and undisturbed sampling – sampling techniques – Split spoon sampler, Thin tube sampler, Stationary piston sampler – Bore log report – Penetration tests (SPT and SCPT) – Data interpretation (Strength parameters and Liquefaction potential) – Selection of foundation based on soil condition.

UNIT II

SHALLOW FOUNDATION

Introduction – Location and depth of foundation – codal provisions – bearing capacity of shallow foundation on homogeneous deposits – Terzaghi's formula and BIS formula – factors affecting bearing capacity – problems - Bearing Capacity from insitu tests (SPT, SCPT and plate load) – Allowable bearing pressure, Settlement – Components of settlement – Determination of settlement of foundations on granular and clay deposits – Allowable settlements – Codal provision – Methods of minimising settlement, differential settlement.

UNIT III

FOOTINGS AND RAFTS

Types of foundation – Contact pressure distribution below footings and raft - Isolated and combined footings – Types and proportioning - Mat foundation– Types, applications uses and proportioning-- floating foundation.

UNIT IV

PILES

Types of piles and their function – Factors influencing the selection of pile – Carrying capacity of single pile in granular and cohesive soil - Static formula - dynamic formulae (Engineering news and Hiley's) – Capacity from insitu tests (SPT and SCPT) – Negative skin friction – uplift capacity – Group capacity by different methods (Feld's rule, Converse Labarra formula and block failure criterion) – Settlement of pile groups – Interpretation of pile load test – Forces on pile caps – under reamed piles – Capacity under compression and uplift.

UNIT V

RETAINING WALLS 9

Plastic equilibrium in soils – active and passive states – Rankine's theory – cohesionless and cohesive soil - Coloumb's wedge theory – condition for critical failure plane - Earth pressure on retaining walls of simple configurations – Graphical methods (Rebhann and Culmann) - pressure on the wall due to line load – Stability of retaining walls.

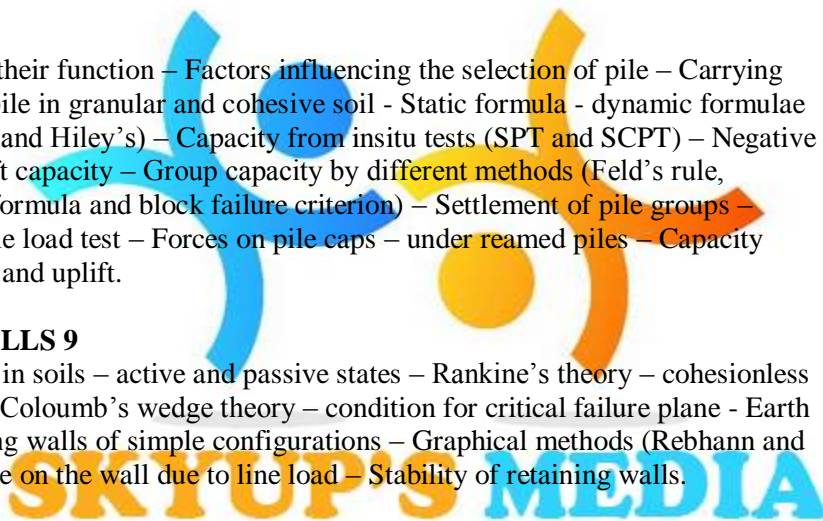

TEXT BOOKS

1. Murthy, V.N.S, “Soil Mechanics and Foundation Engineering”, UBS Publishers Distribution Ltd, New Delhi, 1999.
2. Gopal Ranjan and Rao, A.S.R. ”Basic and Applied Soil Mechanics”, Wiley Eastern Ltd., New Delhi (India), 2003.

REFERENCES

1. Das, B.M. “Principles of Foundation Engineering (Fifth edition), Thomson Books / COLE, 2003
2. Bowles J.E, “Foundation analysis and design”, McGraw-Hill, 1994
3. Punmia, B.C., “Soil Mechanics and Foundations”, Laxmi publications pvt. Ltd., New Delhi, 1995.
4. Venkatramaiah,C.”Geotechnical Engineering”, New Age International Publishers, New Delhi, 1995



UNIT I

SITE INVESTIGATION AND SELECTION OF FOUNDATION

Types of boring

1. Displacement borings

It is combined method of sampling & boring operation. Closed bottom sampler, slit cup, or piston type is forced in to the ground up to the desired depth. Then the sampler is detached from soil below it, by rotating the piston, & finally the piston is released or withdrawn. The sampler is then again forced further down & sample is taken. After withdrawal of sampler & removal of sample from sampler, the sampler is kept in closed condition & again used for another depth.

Features :

- Simple and economic method if excessive caving does not occur. Therefore not suitable for loose sand.
- Major changes of soil character can be detected by means of penetration resistance.
- These are 25mm to 75mm holes.
- It requires fairly continuous sampling in stiff and dense soil, either to protect the sampler from damage or to avoid objectionably heavy construction pit.

2. Wash boring:

It is a popular method due to the use of limited equipments. The advantage of this is the use of inexpensive and easily portable handling and drilling equipments. Here first an open hole is formed on the ground so that the soil sampling or rock drilling operation can be done below the hole. The hole is advanced by chopping and twisting action of the light bit. Cutting is done by forced water and water jet under pressure through the rods operated inside the hole.

In India the “Dheki” operation is used, i.e., a pipe of 5cm diameter is held vertically and filled with water using horizontal lever arrangement and by the process of suction and application of pressure, soil slurry comes out of the tube and pipe goes down. This can be done upto a depth of 8m –10m (excluding the depth of hole already formed beforehand)

Just by noting the change of colour of soil coming out with the change of soil character can be identified by any experienced person. It gives completely disturbed sample and is not suitable for very soft soil, fine to medium grained cohesionless soil and in cemented soil.

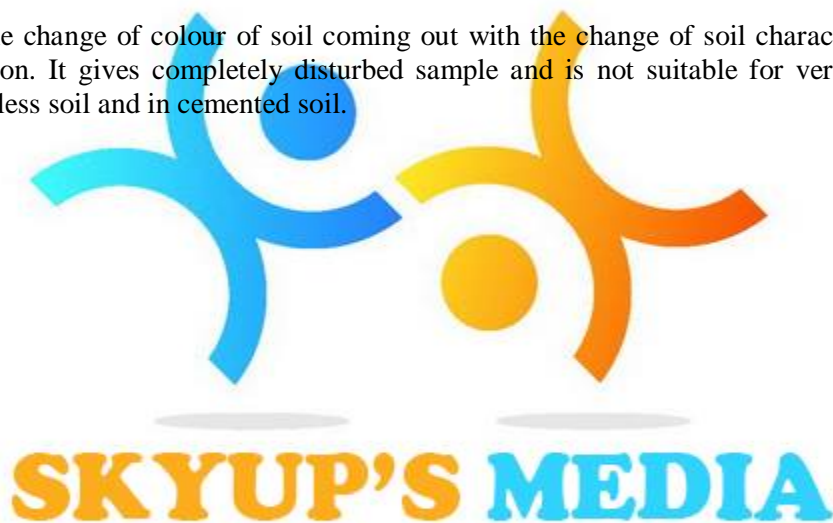

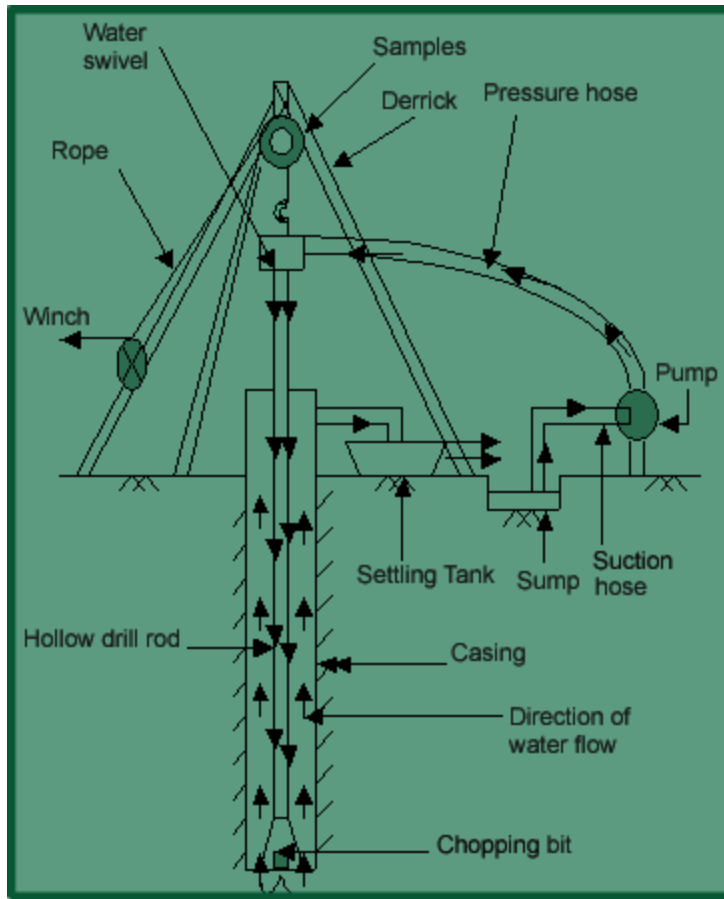

1.1 Planning For Subsurface Exploration

The planning of the site exploration program involves location and depth of borings, test pits or other methods to be used, and methods of sampling and tests to be carried out. The purpose of the exploration program is to determine, within practical limits, the stratification and engineering properties of the soils underlying the site. The principal properties of interest will be the strength, deformation, and hydraulic characteristics. The program should be planned so that the maximum amount of information can be obtained at minimum cost. In the earlier stages of an investigation, the information available is often inadequate to allow a firm and detailed plan to be made. The investigation is therefore performed in the following phases:

1. Fact finding and geological survey

✚ Reconnaissance

1. Preliminary exploration
2. Detailed exploration

1. Fact finding and geological survey

SKYUP'S MEDIA

Assemble all information on dimensions, column spacing, type and use of structure, basement requirements, and any special architectural considerations of the proposed building. Foundation regulations in the local building code should be consulted for any special requirements. For bridges the soil engineer should have access to type and span lengths as well as pier loadings. This information will indicate any settlement limitations, and can be used to estimate foundation loads.

2. Reconnaissance

This may be in the form of a field trip to the site which can reveal information on the type and behavior of adjacent sites and structures such as cracks, noticeable sags, and possibly sticking doors and windows. The type of local existing structure may influence, to a considerable extent, the exploration program and the best foundation type for the proposed adjacent structure. Since nearby existing structures must be maintained, excavations or vibrations will have to be carefully controlled. Erosion in existing cuts (or ditches) may also be observed. For highways, run off patterns , as well as soil stratification to the depth of the erosion cut , may be observed. Rock outcrops may give an indication of the presence or the depth of bedrock.

3. Auger boring

This method is fast and economical, using simple, light, flexible and inexpensive instruments for large to small holes. It is very suitable for soft to stiff cohesive soils and also can be used to determine ground water table. Soil removed by this is disturbed but it is better than wash boring, percussion or rotary drilling. It is not suitable for very hard or cemented soils, very soft soils, as then the flow into the hole can occur and also for fully saturated cohesionless soil.

3. Auger boring

This method is fast and economical, using simple, light, flexible and inexpensive instruments for large to small holes. It is very suitable for soft to stiff cohesive soils and also can be used to determine ground water table. Soil removed by this is disturbed but it is better than wash boring, percussion or rotary drilling. It is not suitable for very hard or cemented soils, very soft soils, as then the flow into the hole can occur and also for fully saturated cohesionless soil. **Soil Sampling**

In general soil samples are categorized as shown in fig. 1.5

Fig. 1.5 Types of samples

Disturbed samples:

The structure of the soil is disturbed to the considerable degree by the action of the boring tools or the excavation equipments.

The disturbances can be classified in following basic types:

Change in the stress condition,

Change in the water content and

Disturbed samples:

The structure of the soil is disturbed to the considerable degree by the action of the boring tools or the excavation equipments.

The disturbances can be classified in following basic types:

Change in the stress condition,

Change in the water content and the void ratio,

Disturbance of the soil structure,

Chemical changes,

Mixing and segregation of soil constituents

The causes of the disturbances are listed below:

Method of advancing the borehole,

Mechanism used to advance the sampler,

Dimension and type of sampler,

Procedure followed in sampling and boring. **Undisturbed samples:** It retains as closely as practicable the true insitu structure and water content of the soil. For undisturbed sample the stress changes can not be avoided. The following requirements are looked for:

No change due to disturbance of the soil structure,

No change in void ratio and water content,

No change in constituents and chemical properties.

$$(C_i) = \frac{D_s - D_c}{D_c} \times 100\%$$

4 Requirement of good sampling process : Inside clearance ratio The soil is under great stress as it enters the sampler and has a tendency to laterally expand. The inside clearance should be large enough to allow a part of lateral expansion to take place, but it should not be so large that it permits excessive deformations and causes disturbances of the sample. For good sampling process, the inside clearance ratio should be within 0.5 to 3 %. For sands silts and clays, the ratio should be 0.5 % and for stiff and hard clays (below water table), it should be 1.5 %.

For stiff expansive type of clays, it should be 3.0 %. area ratio

$$(R) = \frac{L}{H} \times 100\%$$

Where, L is the length of the sample within the tube,

H is the depth of penetration of the sampling tube.

It represents the disturbance of the soil sample. For good sampling the recovery ratio should be 96 to 98 %.

$$(A_r) = \frac{D_w^2 - D_c^2}{D_c^2} \times 100\%$$

Recovery ratio

Wall friction can be reduced by suitable inside clearance, smooth finish and oiling.

The non-returned wall should have large orifice to allow air and water to escape. **In-situ tests General** The in situ tests in the field have the advantage of testing the soils in their natural, undisturbed condition. Laboratory tests, on the other hand, make use of small size samples obtained from boreholes through samplers and therefore the reliability of these depends on the quality of the so called 'undisturbed' samples. Further, obtaining undisturbed samples from non-cohesive, granular soils is not easy, if not impossible. Therefore, it is common practice to rely more on laboratory tests where cohesive soils are concerned. Further, in such soils, the field tests being short duration tests, fail to yield meaningful consolidation settlement data in any case. Where the subsoil strata are essentially non-cohesive in character, the bias is most definitely towards field tests. The data from field tests is used in empirical, but time-tested correlations to predict settlement of foundations. The field tests commonly used in subsurface investigation are:

Penetrometer test

Pressuremeter test

Vane shear test Plate load test

Geophysical methods

Penetrometer Tests :

Standard penetration test (SPT)

Static cone penetration test (CPT)

Dynamic cone penetration test (DCPT) Standard penetration test

The standard penetration test is carried out in a borehole, while the DCPT and SCPT are carried out without a borehole. All the three tests measure the resistance of the soil strata to penetration by a penetrometer. Useful empirical correlations between penetration resistance and soil properties are available for use in foundation design.

This is the most extensively used penetrometer test and employs a split-spoon sampler, which consists of a driving shoe, a split-barrel of circular cross-section which is longitudinally split into two parts and a coupling. IS: 2131-1981 gives the standard for carrying out the test.

Procedure

1. The borehole is advanced to the required depth and the bottom cleaned.
2. The split-spoon sampler, attached to standard drill rods of required length is lowered into the borehole and rested at the bottom
3. The split-spoon sampler is driven into the soil for a distance of 450mm by blows of a drop hammer (monkey) of 65 kg falling vertically and freely from a height of 750 mm. The number of blows required to penetrate every 150 mm is recorded while driving the sampler. The number of blows required for the last 300 mm of penetration is added together and recorded as the N value at that particular depth of the borehole. The number of blows required to effect the first 150mm of penetration, called the seating drive, is disregarded. The split-spoon sampler is then withdrawn and is detached from the drill rods. The split-barrel is disconnected from the cutting shoe and the coupling. The soil sample collected inside the split barrel is carefully collected so as to

preserve the natural moisture content and transported to the laboratory for tests. Sometimes, a thin liner is inserted within the split-barrel so that at the end of the SPT, the liner containing the soil sample is sealed with molten wax at both its ends before it is taken away to the laboratory. The SPT is carried out at every 0.75 m vertical intervals in a borehole. This can be increased to 1.50 m if the depth of borehole is large. Due to the presence of boulders or rocks, it may not be possible to drive the sampler to a distance of 450 mm. In such a case, the N value can be recorded for the first 300 mm penetration. The boring log shows refusal and the test is halted if

50 blows are required for any 150mm penetration

100 blows are required for 300m penetration

10 successive blows produce no advance.

❖ Precautions

The drill rods should be of standard specification and should not be in bent condition.

The split spoon sampler must be in good condition and the cutting shoe must be free from wear and tear.

The drop hammer must be of the right weight and the fall should be free, frictionless and vertical. The SPT is carried out at every 0.75 m vertical intervals in a borehole. This can be increased to 1.50 m if the depth of borehole is large. Due to the presence of boulders or rocks, it may not be possible to drive the sampler to a distance of 450 mm. In such a case, the N value can be recorded for the first 300 mm penetration. The boring log shows refusal and the test is halted if

50 blows are required for any 150mm penetration

100 blows are required for 300m penetration ■10 successive blows produce no advance.

❖ Precautions

The drill rods should be of standard specification and should not be in bent condition.

The split spoon sampler must be in good condition and the cutting shoe must be free from wear and tear.

The drop hammer must be of the right weight and the fall should be free, frictionless and vertical. The height of fall must be exactly 750 mm. Any change from this will seriously affect the N value.

The bottom of the borehole must be properly cleaned before the test is carried out. If this is not done, the test gets carried out in the loose, disturbed soil and not in the undisturbed soil. When a casing is used in borehole, it should be ensured that the casing is driven just short of the level at which the SPT is to be carried out. Otherwise, the test gets carried out in a soil plug enclosed at the bottom of the casing.

When the test is carried out in a sandy soil below the water table, it must be ensured that the water level in the borehole is always maintained slightly above the ground water level. If the water level in the borehole is lower than the ground water level, 'quick' condition may develop in the soil and very low N values may be

recorded. In spite of all these imperfections, SPT is still extensively used because the test is simple and relatively economical.

It is the only test that provides representative soil samples both for visual inspection in the field and for natural moisture content and classification tests in the laboratory. SPT values obtained in the field for sand have to be corrected before they are used in empirical correlations and design charts. IS: 2131-1981 recommends that the field value of N be corrected for two effects, namely, (a) effect of overburden pressure, and (b) effect of dilatancy. (a) Correction for overburden pressure

Several investigators have found that the penetration resistance or the N value in a granular soil is influenced by the overburden pressure. Of two granular soils possessing the same relative density but having different confining pressures, the one with a higher confining pressure gives a higher N value. Since the confining pressure (which is directly proportional to the overburden pressure) increases with depth, the N values at shallow depths are underestimated and the N values at larger depths are overestimated. To allow for this, N values recorded from field tests at different effective overburden pressures are corrected to a standard effective overburden pressure.

Static cone penetration test At field SCPT is widely used of recording variation in the in-situ penetration resistance of soil in cases where in-situ density is disturbed by boring method & SPT is unreliable below water table. The test is very useful for soft clays, soft silts, medium sands & fine sands.

Procedure

By this test basically by pushing the standard cone at the rate of 10 to 20 mm/sec in to the soil and noting the friction, the strength is determined.

After installing the equipment as per IS-4968, part III the sounding rod is pushed in to the soil and the driving is operated at the steady rate of 10 mm/sec approximately so as to advance the cone only by external loading to the depth which a cone assembly available.

For finding combine cone friction resistance, the shearing strength of the soil q_s , and tip resistance q_c is noted in gauge & added to get the total strength

Limitations This test is unsuitable for gravelly soil & soil for having SPT N value greater than 50. Also in dense sand anchorage becomes to cumbersome & expensive & for such cases Dynamic SPT can be used. This test is also unsuitable for field operation since erroneous value obtained due to presence of brick bats, loose stones etc.

Geophysical exploration General Overview Geophysical exploration may be used with advantage to locate boundaries between different elements of the subsoil as these procedures are based on the fact that the gravitational, magnetic, electrical, radioactive or elastic properties of the different elements of the subsoil may be different. Differences in the gravitational, magnetic and radioactive properties of deposits near the surface of the earth are seldom large enough to permit the use of these properties in exploration work for civil engineering projects. However, the resistivity method based on the electrical properties and the seismic refraction method based on the elastic properties of the deposits have been used widely in large civil engineering projects.

Different methods of geophysical explorations 1 Electrical resistivity method:

Electrical resistivity method is based on the difference in the electrical conductivity or the electrical resistivity of different soils. Resistivity is defined as resistance in ohms between the opposite phases of a unit cube of a material.

$$\rho = (RA/L)$$

ρ is resistivity in ohm-cm,

R is resistance in ohms,

A is the cross sectional area (cm²),

L is length of the conductor (cm).

The resistivity values of the different soils are listed in table 1.4

Material	Resistivity (Ω -cm)
Massive rock	> 400
Shale and clay	1.0
Seawater	0.3
Wet to moist clayey soils	1.5 - 3.0

Table 1.4 : Resistivity of different materials

❖ **Procedure**

The set up for the test is given in figure 1.13. In this method, the electrodes are driven approximately 20cms in to the ground and a dc or a very low frequency ac current of known magnitude is passed between the outer (current) electrodes, thereby producing within the soil an electrical field and the boundary conditions. The electrical potential at point C is V_c and at point D is V_d which is measured by means of the inner (potential) electrodes respectively.

$$V_c = \frac{I\rho}{2\pi} \left(\frac{1}{r_1} - \frac{1}{r_2} \right) \text{-----(1.1.1)}$$

$$V_d = \frac{I\rho}{2\pi} \left(\frac{1}{r_3} - \frac{1}{r_4} \right) \text{-----(1.1.2)}$$

where,

ρ is resistivity,

I is current,

r_1, r_2, r_3 and r_4 are the distances between the various electrodes as shown in fig. 1.13.

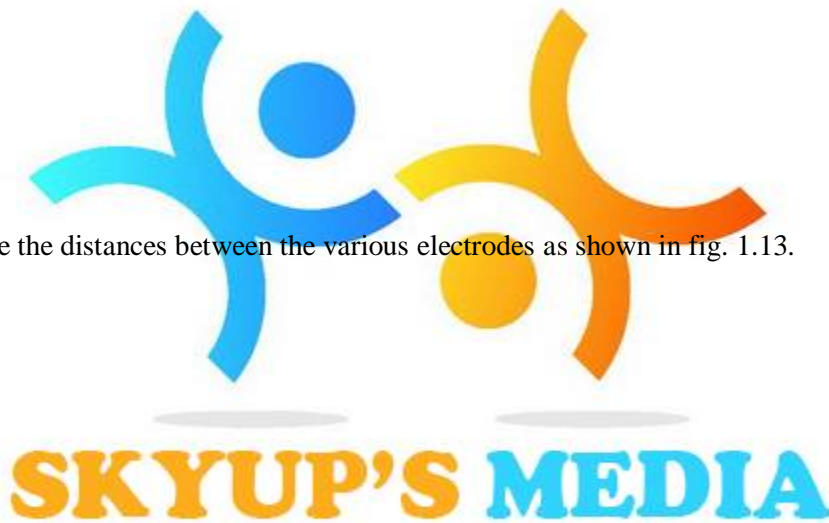

Potential difference between C and D = $V_{CD} = V_C - V_D = \frac{I\rho}{2\pi} \left[\left(\frac{1}{r_1} - \frac{1}{r_2} \right) - \left(\frac{1}{r_3} - \frac{1}{r_4} \right) \right]$ ----- (1.1.3

) $\rho = \frac{2\pi V_{CD}}{I} \left[\frac{1}{\left(\frac{1}{r_1} - \frac{1}{r_2} \right) - \left(\frac{1}{r_3} - \frac{1}{r_4} \right)} \right]$ ----- (1.1.4) If $r_1 = r_4 = (r_2/2) = (r_3/2)$ then resistivity is given

as, $\rho = \frac{2\pi R r_1}{I}$ ----- (1.1.5)

where ,

Resistance $R = (V_{CD} / I)$

Thus, the apparent resistivity of the soil to a depth

approximately equal to the spacing r_1 of the electrode can be computed. The resistivity unit is often so designed that the apparent resistivity can be read directly on the potentiometer.

In “resistivity mapping” or “transverse profiling” the electrodes are moved from place to place without changing their spacing, and the apparent resistivity and any anomalies within a depth equal to the spacing of the electrodes can thereby be determined for a number of points.

approximately equal to the spacing r_1 of the electrode can be computed. The resistivity unit is often so designed that the apparent resistivity can be read directly on the potentiometer.

In “resistivity mapping” or “transverse profiling” the electrodes are moved from place to place without changing their spacing, and the apparent resistivity and any anomalies within a depth equal to the spacing of the electrodes can thereby be determined for a number of points.

Seismic refraction method General This method is based on the fact that seismic waves have different velocities in different types of soils (or rock) and besides the wave refract when they cross boundaries between different types of soils. In this method, an artificial impulse are produced either by detonation of explosive or mechanical blow with a heavy hammer at ground surface or at the shallow depth within a hole. These shocks generate three types of waves. Longitudinal or compressive wave or primary (p) wave, Transverse or shear waves or secondary (s) wave, Surface waves.

It is primarily the velocity of longitudinal or the compression waves which is utilized in this method. The equation for the velocity of the p-waves (V_c) and s-waves (V_s) is given as,

$V_c = \sqrt{\frac{E(1-\mu)}{(1+\mu)(1-2\mu)\rho}}$ ----- (1.2.1)

$V_s = \sqrt{\frac{E}{2\rho(1+\mu)}}$ ----- (1.2.2)

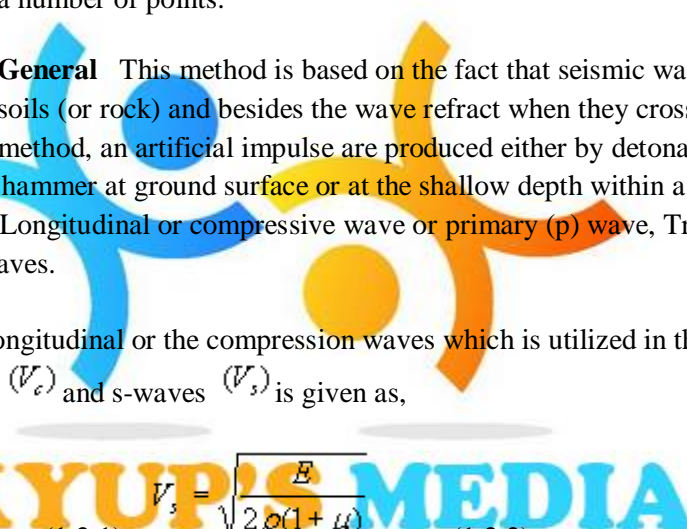

Where,

E is the dynamic modulus of the soil,

μ is the Poisson's ratio,

ρ is density and,

G is the dynamic shear modulus.

v These waves are classified as direct, reflected and refracted waves. The direct wave travel in approximately straight line from the source of impulse. The reflected and refracted wave undergoes a change in direction when they encounter a boundary separating media of different seismic velocities (Refer fig. 1.19). This method is more suited to the shallow explorations for civil engineering purpose. The time required for the impulse to travel from the shot point to various points on the ground surface is determined by means of geophones which transform the vibrations into electrical currents and transmit them to a recording unit or oscillograph, equipped with a timing mechanism. Assumptionshyj

METHODS OF ANALYSIS

LIMIT EQUILIBRIUM

The so-called limit equilibrium method has traditionally being used to obtain approximate solutions for the stability problems in soil mechanics. The method entails a assumed failure surface of various simple shapes—plane, circular, log spiral. With this assumption, each of the stability problems is reduced to one of finding the most dangerous position of the failure or slip surface of the shape chosen which may not be particularly well founded, but quite often gives acceptable results. In this method it is also necessary to make certain assumptions regarding the stress distribution along the failure surface such that the overall equation of equilibrium, in terms of stress resultants, may be written for a given problem. Therefore, this simplified method is used to solve various problems by simple statics.

Although the limit equilibrium technique utilizes the basic concept of upper-bound rules.

Of Limit Analysis, that is, a failure surface is assumed and a least answer is sought, it does not meet the precise requirements of upper bound rules, so it is not a upper bound. The method basically gives no consideration to soil kinematics, and equilibrium conditions are satisfied in a limited sense. It is clear then that a solution obtained using limit equilibrium method is not necessarily upper or lower bound. However, any upper-bound limit analysis solution will be obviously limit equilibrium solution.

INTRODUCTION

Partly for the simplicity in practice and partly because of the historical development of deformable of solids, the problems of soil mechanics are often divided into two distinct groups – the stability problems and elasticity problems. The stability problems deal with the conditions of ultimate failure of mass of soil. Problems of earth pressure, bearing capacity, and stability of slopes most often are considered in this category. The most important feature of such problems is the determination of the loads which will cause the failure of the soil mass. Solutions of

these problems are done using the *theory of perfect elasticity*. The elasticity problems on the other hand deal with the stress or deformation of the soil where no failure of soil mass is involved. Stresses at points in a soil mass under the footing, or behind a retaining wall, deformation around tunnels or excavations, and all settlement problems belong to this category. Solutions to these problems are obtained by using the *theory of linear elasticity*.

Intermediate between the elasticity and stability problems are the problems mentioned above are the problems known as *progressive failure*. Progressive failure problems deal with the elastic- plastic transition from the initial linear elastic state to the ultimate failure state of the soil by plastic flow. The following section describes some of the methods of analysis which are unique with respect to each other.

DIFFERENT METHODS OF ANALYSIS

There are basically four methods of analysis:

- Limit Equilibrium.
- Limit Analysis.
- Method of Characteristics.
- Finite Element / Discrete Element Method. **THEOREMS**

There are two theorems which are used for the various analyses. Some follow one theorem while some methods of analysis follow the other. They are the upper bound and the lower bound theorems.

In the **Upper bound theorem** , loads are determined by equating the external work to the internal work in an assumed deformation mode that satisfies:

Boundary deformation pattern.

Strain and velocity compatibility conditions.

These are kinematically admissible solutions. This analysis gives the maximum value for a particular parameter.

In the **Lower bound theorem** , loads are determined from the stress distribution that satisfies:

Stress equilibrium conditions.

Stress boundary conditions.

Nowhere it violates the yield condition.

These are statically admissible solutions. This analysis gives the minimum value for a particular parameter.

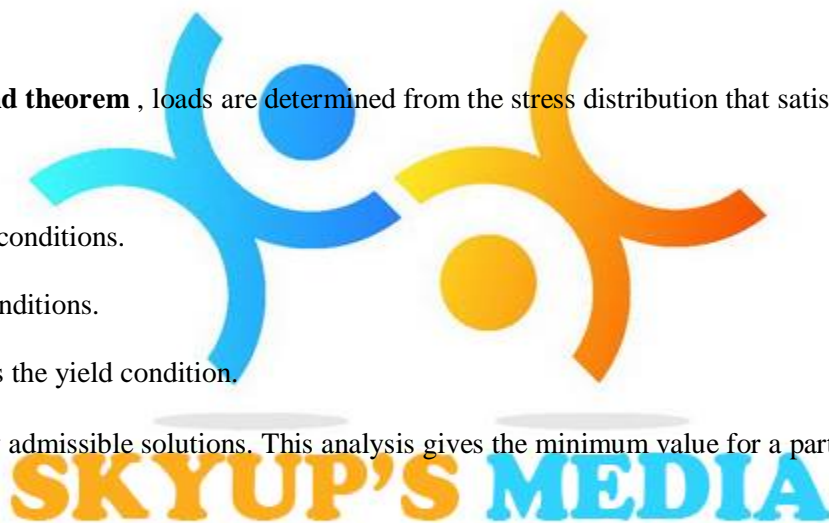

However by assuming different failure surfaces the difference between the values obtained the upper and lower bound theorems can be minimized.

Rankine earth pressure
$$\frac{\partial \sigma_x}{\partial x} + \frac{\partial \tau_{xy}}{\partial y} = X = \gamma$$
 -----(3) where γ is the unit weight of the

soil
$$\frac{\partial \sigma_y}{\partial y} + \frac{\partial \tau_{xy}}{\partial x} = Y = 0$$
 -----(4)

$$\frac{\partial \sigma_y}{\partial y}, \frac{\partial \tau_{xy}}{\partial x} = 0$$
 along a horizontal plane.

at a depth x , integrating equation (3) and (4),

$$\sigma_x = \gamma x + C$$

$$\tau_{xy} = D$$

Boundary conditions:

if there is no surcharge, $C=0, D=0$ at $x=0$.

$$\tau_{xy} = \sigma \sin \phi \sin 2\theta = 0$$

$$\sigma \neq 0, \phi = 0, \sin 2\theta = 0$$

Hence $\theta = 0$ (active conditions) or $\theta = \frac{\pi}{2}$ (passive conditions)

This implies that in passive case, $\theta = \frac{\pi}{2}$ and in active case $\theta = 0$, where θ is the inclination of the major principle stress with the x direction.

Determination of earth pressure coefficients

$$\sigma_x = \gamma x = \sigma(1 + \sin \phi \cos 2\theta)$$

$$\sigma = \frac{\gamma x}{1 + \sin \phi}$$
 (for active case, $\theta = 0$)

$$\sigma_y = \sigma(1 - \sin \phi \cos 2\theta)$$

$$= \frac{\gamma x}{1 + \sin \phi} (1 + \sin \phi)$$
 -----(5)

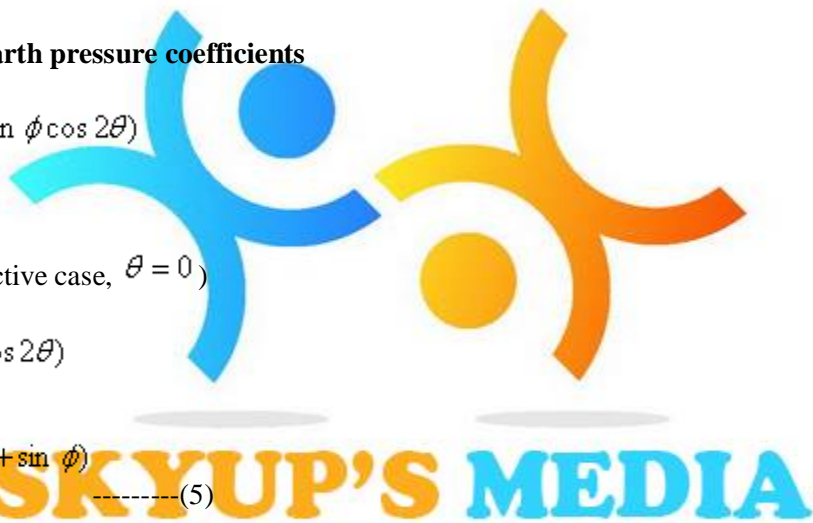

$\sigma_y = K_a \gamma x$ -----(6) from eqn(5) and (6), coefficient of active earth pressure $K_a = \frac{1 - \sin \phi}{1 + \sin \phi}$ similarly, in the passive case, $\theta = \frac{\pi}{2}$

$\sigma_x = \sigma(1 - \sin \phi)$ -----(7)

$\sigma_y = \sigma(1 + \sin \phi)$ -----(8)

from eqn(7) and (8), coefficient of passive earth

pressure $K_p = \frac{1 + \sin \phi}{1 - \sin \phi}$ **Inclination of failure plane**

The failure planes at particular plane will make an angle of $\pm \mu$ with the direction of major principal stress.

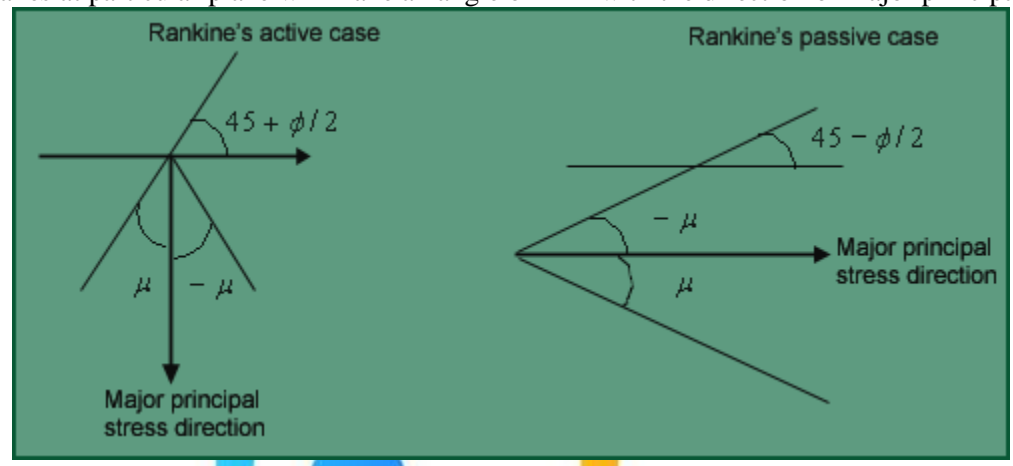
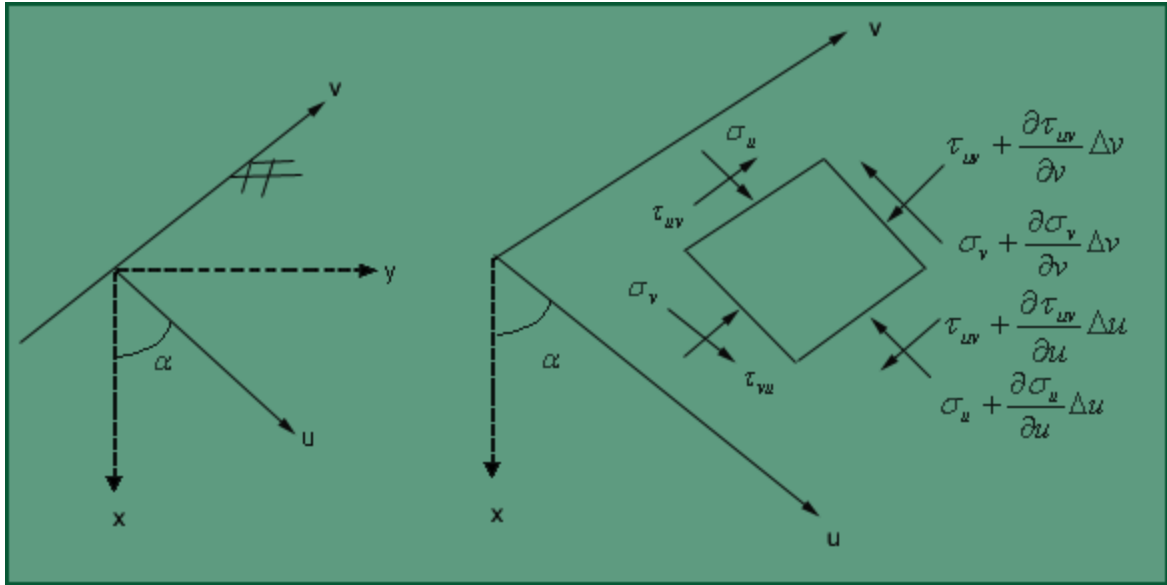

Fig .3.7 Inclination of failure planes

Inclined Ground





Considering the forces in the u and v directions,

$$\frac{\partial \sigma_u}{\partial u} + \frac{\partial \tau_{uv}}{\partial v} = \gamma \cos \alpha$$

$$\frac{\partial \sigma_v}{\partial v} + \frac{\partial \tau_{uv}}{\partial u} = -\gamma \sin \alpha$$

$$\sigma_u = \mu \cos \alpha \text{ -----(9) } \quad \tau_{uv} = -\mu \sin \alpha \text{ -----(10)}$$

dividing eqn 9 by 10 and simplifying ,

$$\frac{\mu \cos \alpha}{-\mu \sin \alpha} = \frac{1 + \sin \phi \cos 2\theta}{\sin \phi \sin 2\theta}$$

$$\sin \alpha \cos 2\theta + \sin 2\theta \cdot \cos \alpha = \frac{\sin \alpha}{\sin \phi}$$

$$\sin(2\theta + \alpha) = \frac{-\sin \alpha}{\sin \phi}$$

thus,
$$\theta = \frac{1}{2} \left[\sin^{-1} \left(\frac{-\sin \alpha}{\sin \phi} \right) - \alpha \right]$$

UNIT II SHALLOW FOUNDATION

Introduction

A foundation is an integral part of the structure which transfers the load of the superstructure to the soil. A foundation is that member which provides support for the structure and its loads. It includes the soil and rock of earth's crust and any special part of structure that serves to transmit the load into the rock or soil. The different types of the foundations are given in fig. 4.1

Different types of footings

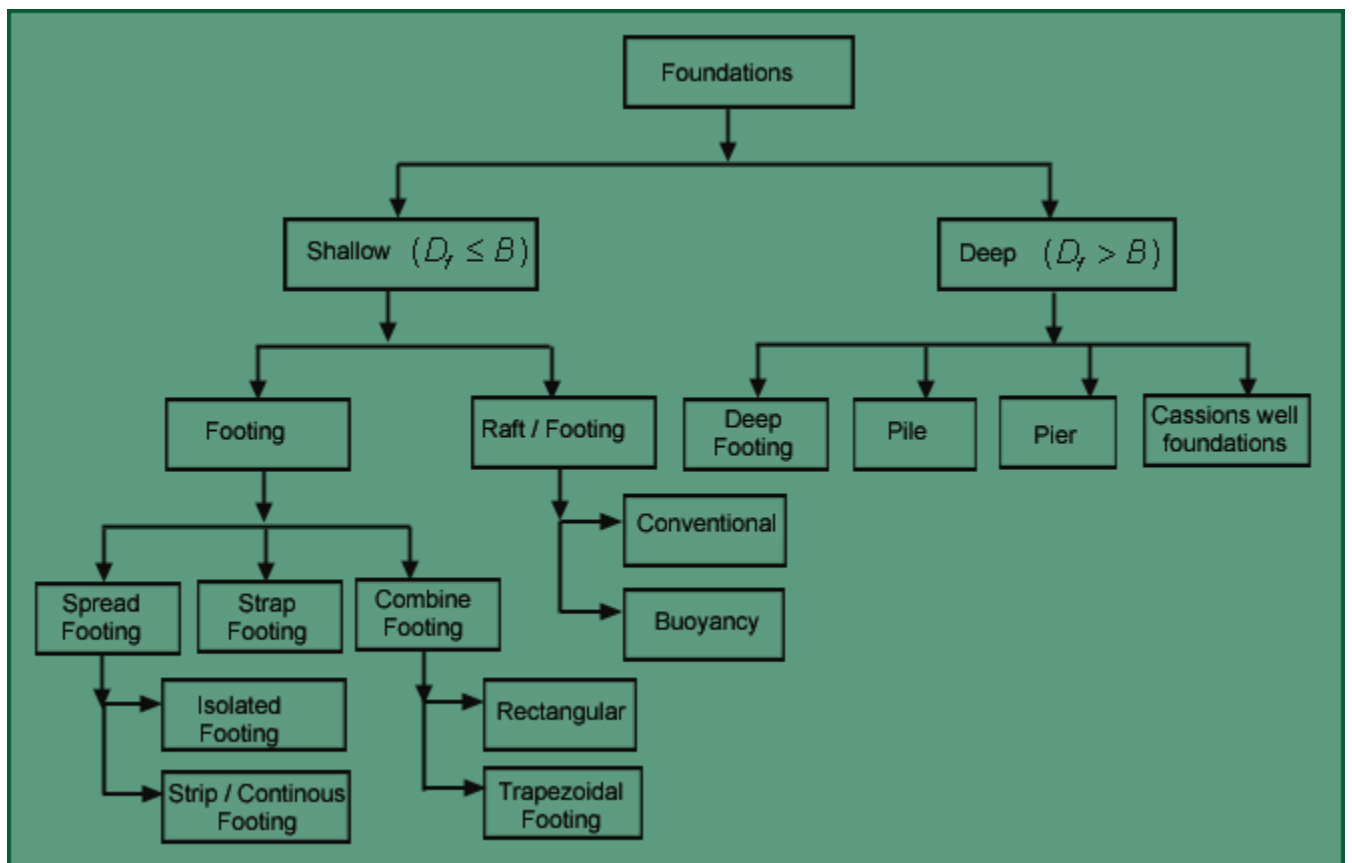

Fig. 4.1 Different types of footings

Methods of determining bearing capacity The various methods of computing the bearing capacity can be listed as follows:

- Presumptive Analysis
- Analytical Methods
- Plate Bearing Test
- Penetration Test
- Modern Testing Methods

■ Centrifuge Test **Prandtl's Analysis**

Prandtl (1920) has shown that if the continuous smooth footing rests on the surface of a weightless soil possessing cohesion and friction, the loaded soil fails as shown in figure by plastic flow along the composite surface. The analysis is based on the assumption that a strip footing placed on the ground surface sinks vertically downwards into the soil at failure like a punch.

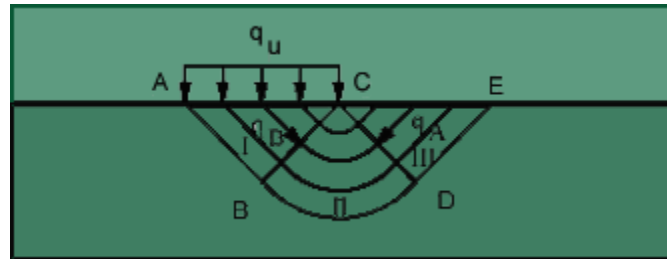

Fig 4.8 Prandtl's Analysis

Prandtl analysed the problem of the penetration of a punch into a weightless material. The punch was assumed rigid with a frictionless base. Three failure zones were considered.

- Zone I is an active failure zone
- Zone II is a radial shear zone
- Zone III is a passive failure zone identical for $\phi = 0$

Zone I consist of a triangular zone and its boundaries rise at an angle $45 + \phi/2$ with the horizontal two zones on either side represent passive Rankine zones. The boundaries of the passive Rankine zone rise at angle of $45 - \phi/2$ with the horizontal. Zones 2 located between 1 and 3 are the radial shear zones. The bearing capacity is given by (Prandtl 1921) as

$$q_d = cN_c$$

where c is the cohesion and N_c is the bearing capacity factor given by the expression

$$N_c = \cot \phi e^{\pi \tan \phi} \tan^2 [(45 + \phi/2) - 1]$$

Reissner (1924) extended Prandtl's analysis for uniform load q per unit area acting on the ground surface. He assumed that the shear pattern is unaltered and gave the bearing capacity expression as follows.

$$q_d = cN_c + qN_q$$

$$N_q = e^{\pi \tan \phi} \tan^2 (45 + \phi/2)$$

$$N_c = \cot \phi e^{\pi \tan \phi} \tan^2 [(45 + \phi/2) - 1]$$

if $\phi = 0$, the logspiral becomes a circle and N_c is equal to $(\pi + 2)$, also N_q becomes 1. Hence the bearing capacity of such footings becomes

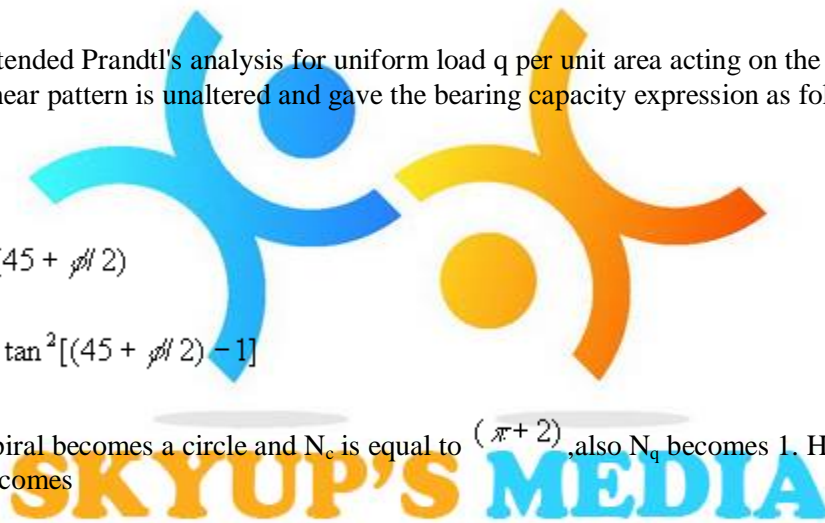

$$q_d = (\pi + 2)c + q$$

$$= 5.14c + q$$

if $q=0$,

$$\text{we get } q_d = 5.14c = 2.57q_u$$

where q_u is the unconfined compressive strength.

Terzaghi's Bearing Capacity Theory Assumptions in Terzaghi's Bearing Capacity Theory

- Depth of foundation is less than or equal to its width.
- Base of the footing is rough.
- Soil above bottom of foundation has no shear strength; is only a surcharge load against the overturning load
- Surcharge upto the base of footing is considered.
- Load applied is vertical and non-eccentric.
- The soil is homogenous and isotropic.
- L/B ratio is infinite.

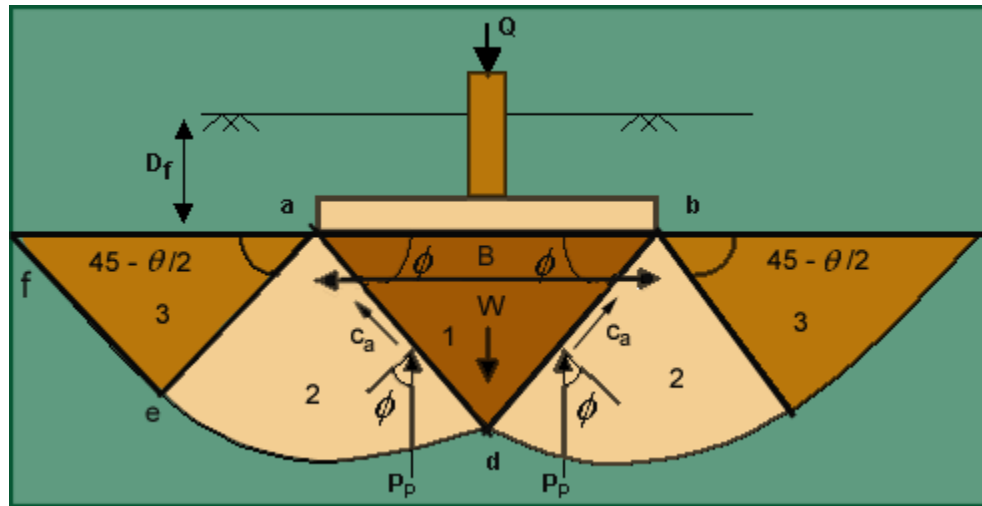

Fig. 4.9 Terzaghi's Bearing Capacity Theory

Consider a footing of width B and depth D_f loaded with Q and resting on a soil of unit weight γ . The failure of the zones is divided into three zones as shown below. The zone 1 represents an active Rankine zone, and the zones 3 are passive zones. The boundaries of the active Rankine zone rise at an angle of $45 + \phi/2$, and those of the passive zones at $45 - \phi/2$ with the horizontal. The zones 2 are known as zones of radial shear, because the lines that constitute one set in the shear pattern in these zones radiate from the outer edge of the base of the footing. Since the base of the footings is rough, the soil located between it and the two surfaces of sliding remains in a state of equilibrium and acts as if it formed part of the footing. The surfaces ad and bd rise at ϕ to the horizontal. At the instant of failure, the pressure on each of the surfaces ad and bd is equal to the resultant of the passive earth pressure P_p and the cohesion force C_a . since slip occurs along these faces, the resultant earth pressure acts at angle ϕ to the

normal on each face and as a consequence in a vertical direction. If the weight of the soil adb is disregarded, the equilibrium of the footing requires that

$$Q_d = 2P_p + 2C_a \sin \phi = 2P_p + Bc \tan \phi \text{----- (1)}$$

The passive pressure required to produce a slip on def can be divided into two parts, P'_p and P''_p . The force P'_p represents the resistance due to weight of the mass $adef$. The point of application of P'_p is located at the lower third point of ad . The force P''_p acts at the midpoint of contact surface ad .

The value of the bearing capacity may be calculated as :

$$Q_d = 2(P_p + P_c + P_q + \frac{1}{2} Bc \tan \phi) \text{----- (2)}$$

$$N_c = \frac{2P_c}{Bc} + \tan \phi$$

by introducing into eqn(2) the following values:

$$N_q = \frac{2P_q}{B \cdot D_f}$$

Footing subjected to **Concentric loading** Problem 1 Shallow footing subjected to vertical load along with moment. Design a column footing to carry a vertical load of 40 t (DL+LL) and moment of 1000 Kg-m.

$$q_{allow} = 20t/m^2, f_y = 415N/mm^2, f_{ck} = 15N/mm^2$$

Design of the Column.

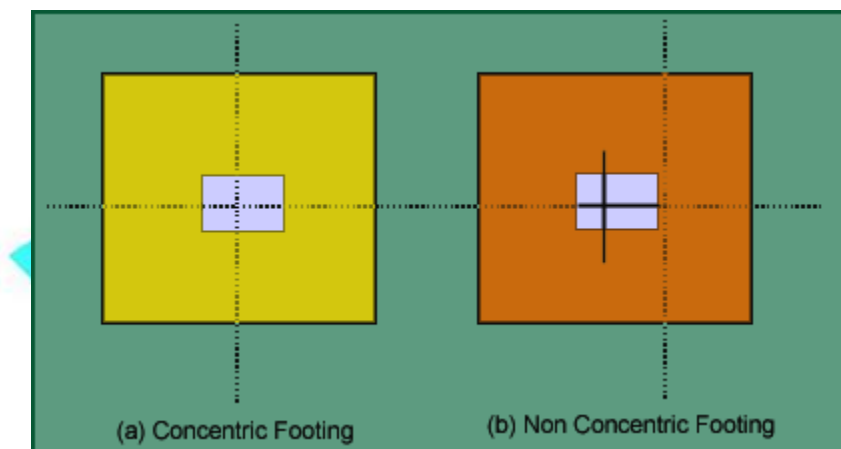

Fig. 4.26 Concentric & Non Concentric Footing

$$P_U = 40 \times 1.5 = 60t = 60 \times 10^4 \text{ N}$$

$$M_U = 1.5 \times 1000 \text{ Kg} \cdot \text{m} = 1500 \times 10^4 \text{ N} \cdot \text{mm} \quad \text{Trial 1 Let assume } b = 300 \text{ mm} \ \& \ D (L) = 400 \text{ mm}$$

$$\frac{P_U}{f_{CK} \cdot b \cdot D} = 0.33$$

$$\frac{M_U}{f_{CK} \cdot b \cdot D^2} = 0.021$$

$$\frac{d'}{D} = \frac{40 + \frac{20}{2}}{400} = 0.125$$

See chart 33 of SP-16. Assume Diameter of bar 20 mm.

It shows for this trial No Reinforcement required, but practically we have to provide reinforcement.

Trial 2

b = 250 mm, D = 300 mm.

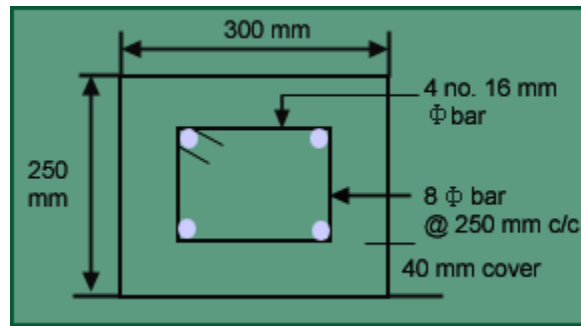

Fig -4.27 Column Section

$$\frac{P_U}{f_{CK} \cdot b \cdot D} = 0.53$$

$$\frac{M_U}{f_{CK} \cdot b \cdot D^2} = 0.044$$

$$\frac{d'}{D} = 0.167$$

$$\frac{P_t}{f_{CK}} = 0.06$$

therefore

$$p_t = 0.06 \times 15 = 0.9\%$$



$$A_{st_{required}} = \frac{0.9}{100} \times 250 \times 350 = 675 \text{ mm}^2$$

Design of footing

Size of the footing

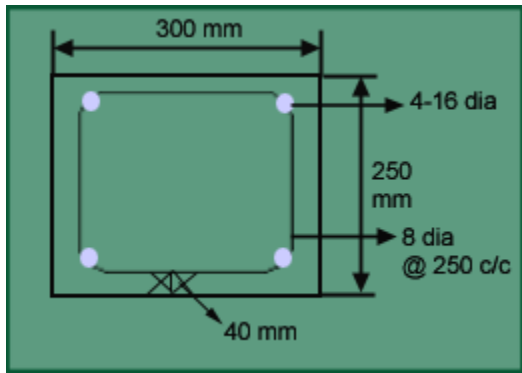

Fig 4.28 Details of the coulumn

Let D=500mm

For concentric footing;

$$(q_a - (\gamma_c - \gamma_s)D) = \frac{V}{BL} + \frac{6Ve}{BL^2}$$

$$Q_a = 20 \text{ t/m}^2, \gamma_c = 2.5, \gamma_s = 1.8$$

$$V=40 \text{ t} = 40 \times 10^4 \text{ N}, e=M/V=1000 \times 10^4 / 40 \times 10^4 = 25 \text{ mm}$$

For no tension case: $\frac{V}{BL} = \frac{6Ve}{BL^2} = 0$ Determination of L & B for different values of L & B.

L in m	B in m
1.0	2.34
2.0	1.1
2.2	0.988

$$L=6e=150 \text{ mm}$$

$$19.65 = \frac{40}{BL} + \frac{6}{BL^2}$$

or
$$B = \frac{6 + 40L}{19.65L^2}$$

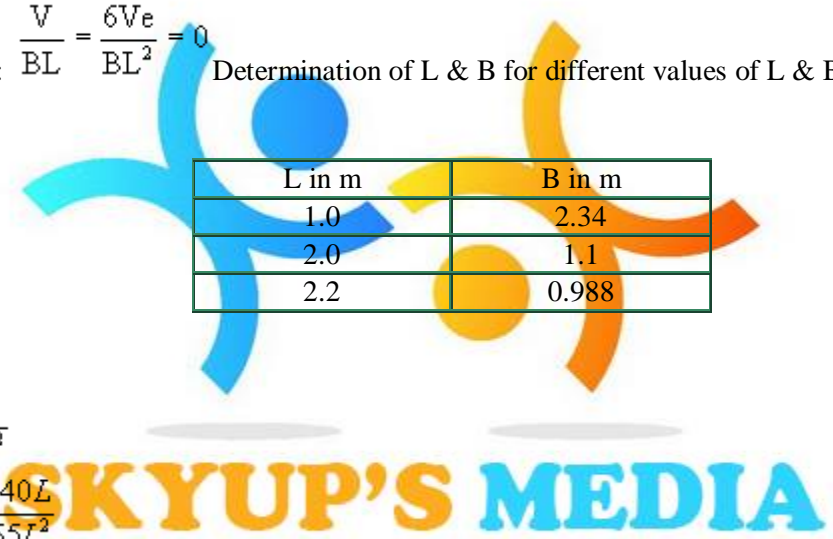

Let provide footing size is 2.2 m*1.0 m.

Check:

$$Q_{min} = \frac{40}{1 \times 2.2} - \frac{6 \times 1}{1 \times 2.2^2} = 16.94 \text{ t/m}^2$$

$$Q_{min} = \frac{40}{1 \times 2.2} + \frac{6 \times 1}{1 \times 2.2^2} = 19.92 \text{ t/m}^2$$

iii Thickness of footing a. Wide beam shear

Factored intensity of soil pressure,

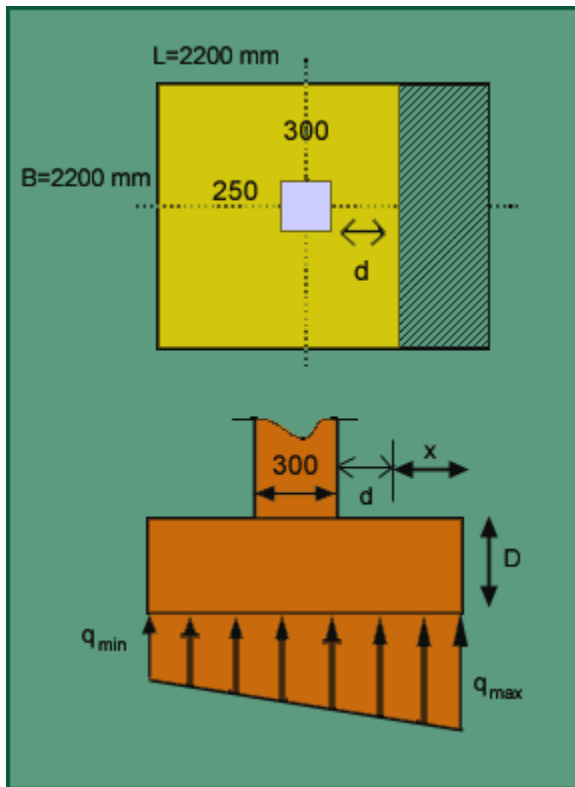

$$q_{us} = \left\{ q_{max} - \frac{q_{max} - q_{min}}{L} x \right\} 1.5$$

$$= \left(19.42 - \frac{19.42 - 16.94}{2200} x \right) 1.5 \text{ now, } V = \int_0^x q_{us} dx$$

For critical section of wide beam shear: $x = (2.2/2) - (0.3/2) - d = 0.95 - d$

$$V = \int_0^{0.95-d} (29.13 - 1.691x) dx = -0.85d^2 - 28.52d + 26.91$$

Assuming $P_t = 0.2\%$, and from table 16 of SP-16

$$\tau = 0.32 M_{ps} = 32t/m^2$$

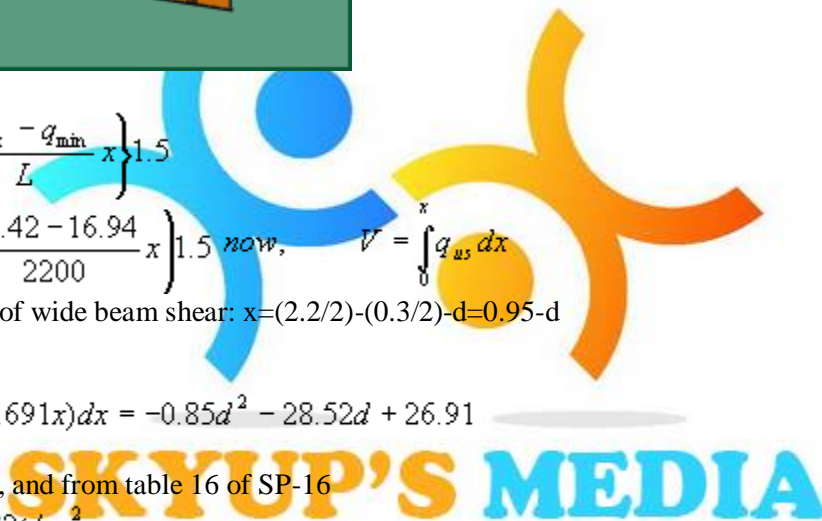

$$V * B = \pi * B * d$$

$$0.0265d^2 + 0.86 - 0.841 = 0$$

By trial and error method, $d = 0.45$ m

Fig 4.29 Section for wide beam shear and upward earth pressure diagram Punching shear (two way shear)

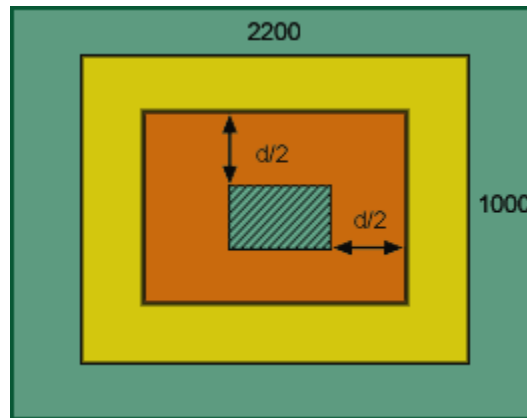

Fig 4.30 Section for two way at a distance of $d/2$ from face of the column round

$$q_{avg} = \frac{q_{max} + q_{min}}{2} \times 1.5 = 27.27 \text{ t/m}^2$$

$$\text{Critical area} = (1.1 + 4d) d \text{ m}^2$$

$$\text{IS: 456-1978, } \beta_c = 250/300 = 0.83$$

$$K_s = (0.5 + \beta_c) = 1.33 > 1.0$$

Therefore $K_s = 1.0$

$$\tau_c = 0.25 \sqrt{f_{ck}} = 96.8 \text{ t/m}^2$$

$$\tau'_c = k_s \tau_c = 96.8 \text{ t/m}^2$$

$$P_{ult} = 40.0 \times 1.5 = 60 \text{ t/m}^2$$

$$(1.1 + 4d) * 96.8 = 60 - 27.27(0.3 + d) (0.25 + d)$$

by trial and error, $d = 0.255$ m

$$d_{req} = 450 \text{ mm, } D = 450 + 40 + 20/2 = 500 \text{ mm}$$

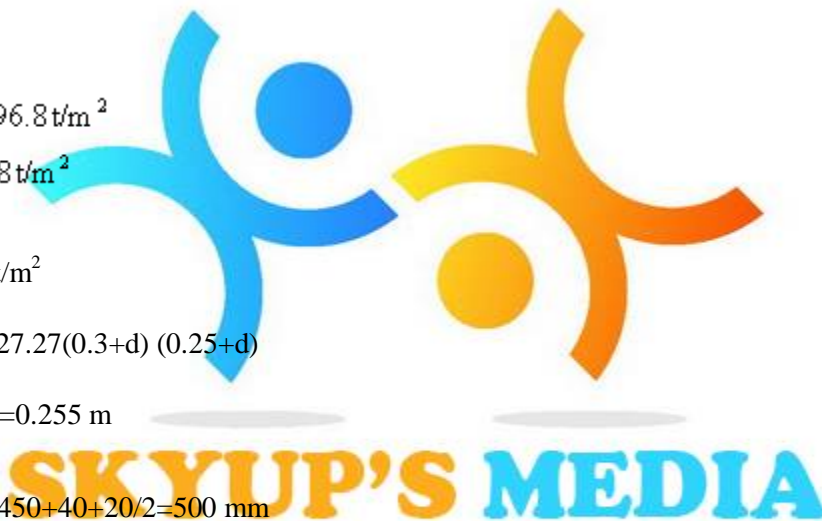

Flexural reinforcement

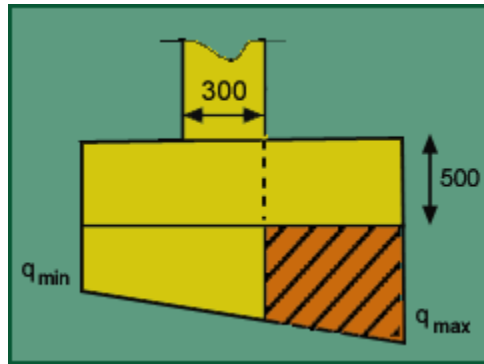

Fig 4.31 Section for bending moment

$$q = \left\{ q_{\max} - \frac{q_{\max} - q_{\min}}{L} x \right\}$$

$$= \left(19.42 - \frac{19.42 - 16.94}{2200} x \left(\frac{2.2}{2} - \frac{0.3}{2} \right) \right)$$

$$= 18.35 \text{ t/m}^2$$

$$q_{us} = 18.35 * 1.5 = 27.53 \text{ t/m}^2$$

$$q_{umax} = 19.42 * 1.5 = 29.13 \text{ t/m}^2$$

$$BM = \{ 27.53 * 0.5 * 0.952 \} + \{ (29.13 - 27.53) * 0.95 * 2/3 * 0.95 \} = 13.386 \text{ t.m}$$

$$\frac{M_u}{bd^2} = \frac{13.386 \times 10^7}{1000 \times 450^2} = 0.66 \text{ N/mm}^2$$

Table I of SP-16, $P_{treq} = 0.193\%$

For wide beam shear $P_t = 0.2\%$

$$A_{streq} = 0.2 * 1000 * 450 / 100$$

Provide 16mm diameter torq bars @200 mm c/c in both directions.

According to clause 33.3.1 of IS: 456

$$\lambda = 2.2 / 1 = 2.2$$

$$A_{st} \text{ in central band width} = 2 / (\lambda + 1) * A_{st} \text{ total in short direction} = 2 / (2.2 + 1) * 1980 = 1237.5 \text{ mm}^2$$

Hence 16 mm dia @200c/c in longer direction satisfied all criteria & 16 dia @150c/c for central band.

v Check for development length

$$\text{Clause 25.2.1 } L_d = \frac{16 * 415}{4 * 1.6} = 1037.5 \text{ mm}$$

L_d

Now length of bars provided, $(2200-300)/2 = 950 \text{ mm} <$

Provide extra development length of $1037.5-950=87.5 \text{ mm}$ say 90 mm on side of the footing.

VI. Transfer of load at base of column

Clause 34.4

Permissible bearing pressure, $q_b = 0.45 * 15 = 6.75 \text{ } M_{pa} = 675 \text{ t/m}^2$

$$A_1 = 1 * 2.2 = 2.2 \text{ m}^2$$

$$A_2 = 0.3 * 0.25 = 0.075 \text{ m}^2$$

$$\sqrt{\frac{A_1}{A_2}} = 5.42 > 2.0$$

$$q_{perm} = q_p * \sqrt{\frac{A_1}{A_2}} = 675 * 2.0 = 1350 \text{ t/m}^2$$

$$q_{max \text{ at col base}} = \left(\frac{V}{BL} + \frac{6V_e}{BL^2} \right) * 1.5$$

$$= \left(\frac{40}{0.3 * 0.25} + \frac{6 * 1}{0.3^2 * 0.25} \right) * 1.5$$

$$= 1200 \text{ t/m}^2 < q_{perm}$$

ok

Footing subjected to eccentric loading Problem 2

Design a non-concentric footing with vertical load = 40t and moment = 2tm. Allowable bearing

capacity = 20t/m². $f_{ck} = 15 \text{ N/mm}^2$, $f_y = 415 \text{ N/mm}^2$.

■Determination of size of column:

$$P = 40 \text{ t.} \Rightarrow P_u = 40 * 1.5 = 60 \text{ t.}$$

$$M = 2 \text{ tm.} \Rightarrow M_u = 2 * 1.5 = 3 \text{ tm.}$$

Trial I

Let us assume footing size $b = 250 \text{ mm}$, $D = 350 \text{ mm}$.

$$\frac{P_u}{f_{ck} b d} = \frac{60 * 10^4}{15 * 250 * 350} = 0.46 \text{ N/mm}^2$$

$$\frac{M_u}{f_{ck} b d^2} = \frac{3 * 10^7}{15 * 250 * 350^2} = 0.065 \text{ N/mm}^2$$

SKYUP'S MEDIA

$$\frac{d'}{D} = \frac{40 + 20/2}{350} = 0.14$$

(see chart for 0.15)

$$\frac{p}{f_{ck}} = 0.06$$

Ref. Chart 33, SP-16 => f_{ck} or, $p = 0.9\%$

$$A_{st} = \frac{0.9}{100} \times (250 \times 350) = 787.5 \text{ mm}^2$$

Provide 4 nos. 16 ϕ bars as longitudinal reinforcement and 8 ϕ stirrups @250mm c/c as transverse reinforcement.

Determination of the size of the footing

Depth of the footing assumed as $D = 500 \text{ mm}$. For non-concentric footing ,

$$\text{Area required} = \frac{P}{[q_a - (\gamma_c - \gamma_s)D]} = \frac{40}{[20 - (2.5 - 1.8) \times .5]} = 2.036 \text{ m}^2$$

Adopt a rectangular footing of size $2 \text{ m} \times 1.1 \text{ m}$ and depth 0.5 m .

Eccentricity of footing = $M/P = 50 \text{ mm}$.

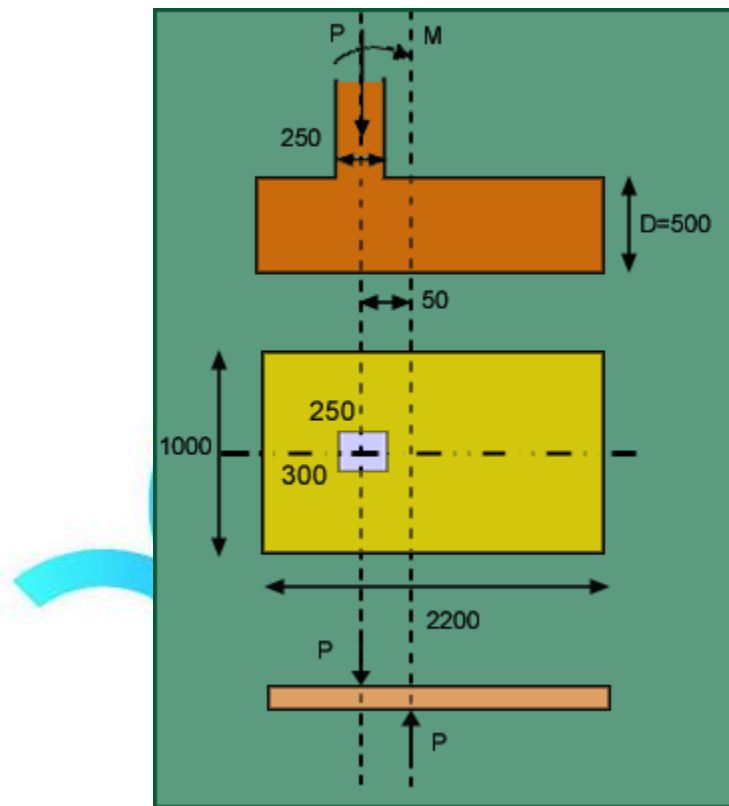

Fig. 4.32 Elevation and Plan of a non-concentric footing

- Determination of design soil pressure

Soil reaction = $P = 40t$.

$$= 40 / (2 * 1.1) = 18.2 \text{ t/m}^2 < 20 \text{ t/m}^2$$

Therefore, $\tau = 18.2 * 1.5 = 27.3 \text{ t/m}^2 = 0.273 \text{ N/mm}^2$.

■ **Determination of depth of footing:**

a. Wide beam shear:

Consider a section at a distance 'd' from the column face in the longer direction.

Assuming $P_t = 0.2\%$ for $f_{ck} = 15 \text{ N/mm}^2$, $\tau_c = 0.32 \text{ N/mm}^2$.

$$\tau_c \cdot B \cdot d = q_{ws} \cdot B \cdot (L_1 - d)$$

$$0.32 * d = 0.273 * (0.875 - d)$$

Therefore, $d = 0.403 \text{ m}$

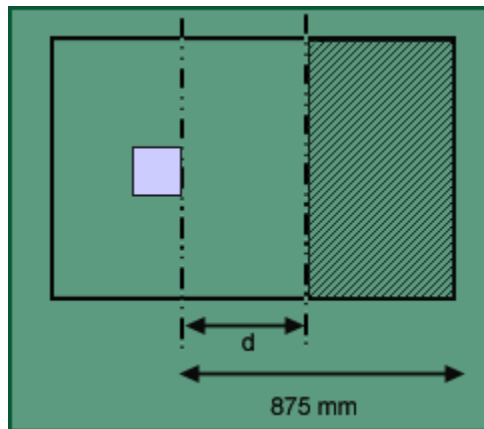

b. Punching shear:

Fig. 4.33 Section for wide beam shear

Critical area for punching shear:

$$= 2 * (350 + d + 250 + d) * d$$

$$= 4d(300 + d)$$

Clause :31.6.3.1 (IS 456:2000)

$$k_s = 0.25 / 0.35 = 0.71$$

$$K_s = 0.5 + k_s = 1.21 > 1.0$$

Therefore, take, $K_s = 1.0$.

$$\tau_c = 0.25 * (15) * 0.5 = 0.968 \text{ N/mm}^2$$



$$\tau' = \tau \cdot K_s = 0.968 \text{ N/mm}^2$$

$$96.8 * 4d * (0.3 + d) = 60 - 27.3 * (0.35 + d) * 8(0.25 + d)$$

$$d = 0.246 \text{ m}$$

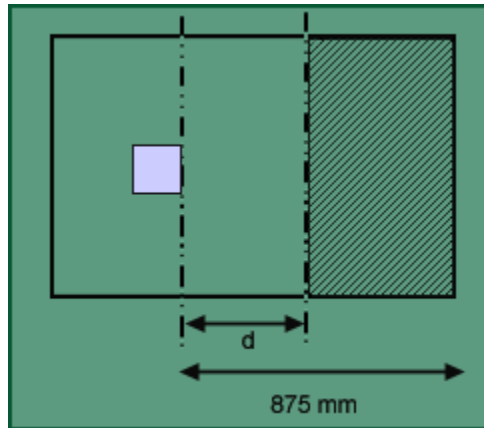

Therefore, from the punching and wide beam shear criteria we get, 'd' required is

Fig. 4.34 Section for wide beam shear

403 mm. D required is $(403 + 40 + 20/2) = 453 \text{ mm} < 500 \text{ mm}$ (D provided). OK.

Flexural reinforcement:

Design soil pressure $(q) = 27.3 \text{ t/m}^2$

Bending moment at the face of the column in the longer direction

$$M_u = 27.3 * 0.875^2 / 2 = 10.45 \text{ tm/m width}$$

d provided = 450mm.

$$\frac{M_u}{bd^2} = \frac{10.45}{1 * 0.45^2} = 51.6 \text{ t/m}^2 = 0.516 \text{ N/mm}^2$$

For singly reinforced section, table 1, SP-16, $p_t = 0.147 \text{ N/mm}^2$

$$\frac{0.147}{100} * (1000 * 450) = 661.5 \text{ mm}^2 / \text{mwidth}$$

Area of steel required =

Spacing using 16 ϕ bars = $201 * 1000 / 661.5 = 303 \text{ mm c/c}$.

Provide 16 F bars as longitudinal reinforcement @ 300mm c/c in longer direction.

Cl. 33.4.1. (IS-456:2000)

$B = 2.0 / 1.1 = 1.82$ **SKYUP'S MEDIA**

Area of steel in the longer direction = $661.5 * 2 = 1323 \text{ mm}^2$

Area of steel in the central band = $2 / (1.82 + 1) * 1323 = 938 \text{ mm}^2$

Spacing = 207.6 mm.

Provide 16 ϕ bars as longitudinal reinforcement @ 200mm c/c in shorter direction in the central band. For remaining portion provide spacing @ 330mm c/c.

The central band width = width of the foundation = 1100mm.

Check for development length:

Cl. 26.2.1 (IS 456 :2000)

$$L_d = \frac{\phi \sigma_s}{4 \tau_{bd}} = \frac{16 \times 415}{4 \times 1.6} = 1037.5 \text{ mm.}$$

Now, length of bars provided = $(2000 - 350)/2 = 825 \text{ mm.} < L_d$.

Extra length to be provided = $(1037.5 - 825) = 212.5 \text{ mm.}$

Provide development length equal to 225mm at the ends.

Transfer of load at the column footing junction :

Cl. 33.4 (IS 456:2000)

Assuming 2:1 load dispersion,

Required L = $\{350 + 2*500*2\} = 2350 \text{ mm} > 2000 \text{ mm.}$

Required B = $\{250 + 2*500*2\} = 2250 \text{ mm} > 1100 \text{ mm.}$

$$A_1 = 2 * 1.1 = 2.2 \text{ m}^2.$$

$$A_2 = 0.25 * 0.35 = 0.0875 \text{ m}^2$$

$$\ddot{O} (A_1 / A_2) = 5.01 > 2.0. \text{ Take as } 2.0.$$

$$q_{\text{perm.}} = q_b * \ddot{O} (A_1 / A_2) = 675 * 2 = 1350 \text{ t/m}^2.$$

$$q_{\text{max}} = 40 * 1.5 / (0.25 * 0.35) * \{1 + 6 * 0.05 / 0.35\} = 1273 \text{ t/m}^2 < 1350 \text{ t/m}^2.$$



Therefore, the junction is safe.

Actually there is no need to extend column bars inside the footing, but as a standard practice the column bars are extended upto a certain distance inside the footing.

Design of strap footing: Example:

The column positions are as shown in fig. 4.35. As column one is very close to the boundary line, we have to provide a strap footing for both footings.

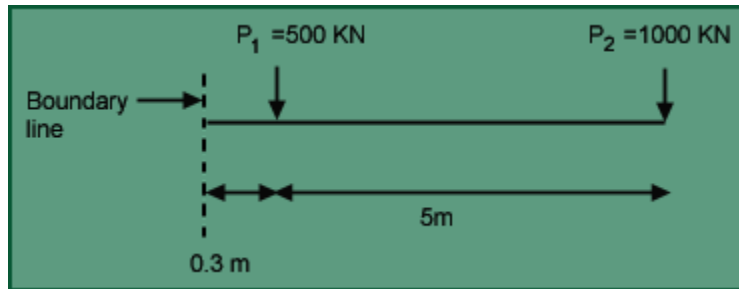

Fig. 4.35 Strap footing

■Design of the column Column A:

$$P_u = 750 \text{ kN}$$

Let $f_t = 0.8\%$, so, $A_s = 0.008A$ and $A_c = 0.992A$,

Where, A is the gross area of concrete.

As per clause 39.3 of IS 456-2000,

$$750 \times 103 = (0.4 \times 15 \times 0.992A) + (0.67 \times 415 \times 0.008A)$$

$$A = 91727.4 \text{ mm}^2$$

Provide column size (300 x 300) mm

$$\therefore 750 \times 103 = 0.4 \times 15 \times (1 - (p_t/100)) \times 90000 + 0.67 \times 415 \times (f_t/100) \times 90000$$

$$\therefore f_t = 0.86\%$$

$$A_{st \text{ required}} = (0.86/100) \times (300)^2 = 774 \text{ mm}^2$$

Provide 4 no's tor 16 as longitudinal reinforcement with tor 8 @ 250 c/c lateral ties.

Column B:

$$P_u = 1500 \text{ kN}$$

Provide column size (400 x 400) mm

$$\therefore 1500 \times 103 = 0.4 \times 15 \times (1 - (f_t/100)) \times 160000 + 0.67 \times 415 \times (p_t/100) \times 160000$$

$$\therefore f_t = 1.24\% , A_{st \text{ required}} = (1.24/100) \times (300)^2 = 1985 \text{ mm}^2$$

Provide 8 no.s tor 16 as longitudinal reinforcement with tor 8 @ 250 c/c lateral ties.

Footing design

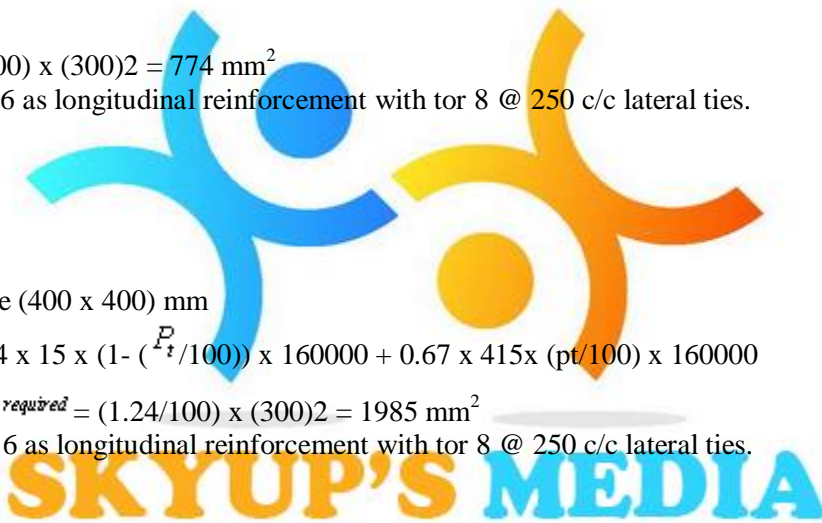

Let us assume eccentricity $e = 0.9\text{m}$.

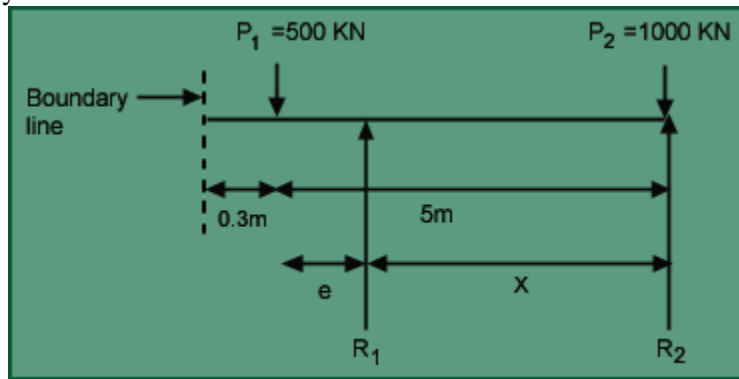

Fig. 4.36 Strap footing – soil reaction

Taking moment about line P_2 ,

$$P_1 \times 5 - R_1 \times (5-e) = 0$$

$$\therefore R_1 = \frac{5 \times 500}{5 - 0.9} = 609.8 \text{ kN}$$

$$\therefore R_2 = P_1 + P_2 - R_1 = 500 + 1000 - 609.8 = 890.2 \text{ kN}$$

Footing size:

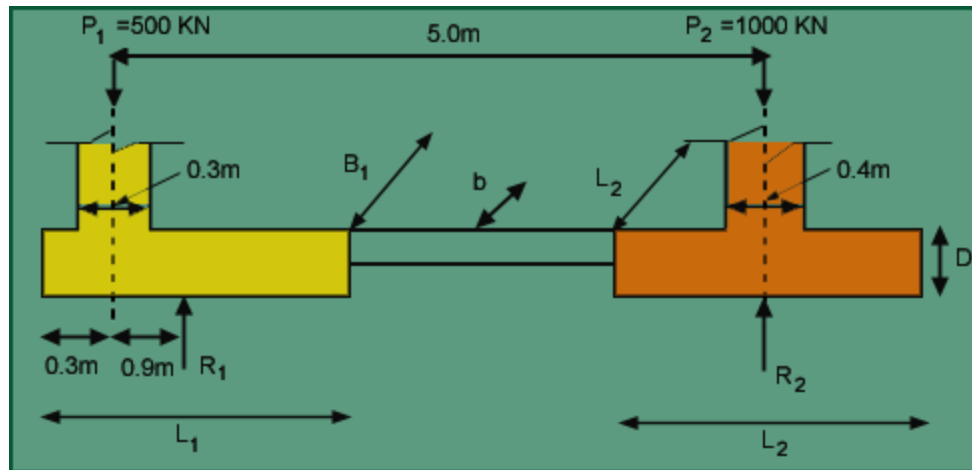

Fig. 4.37 Footing sizes

For footing A:

$$L_1 = 2(0.9 + 0.3) = 2.4\text{m}$$

Assume overall thickness of footing, $D = 600\text{mm}$.

$$B_1 = \frac{R_1}{(q_u - (\gamma - \gamma_s)D)L_1} = \frac{609.8}{(20 - (2.5 - 1.8)0.6)2.4} = 1.298\text{m}$$

For footing B:

Assume square footing of size L_2 , 89.02

$$L_{22} = \frac{R_2}{(q_a - (\gamma_c - \gamma_s)D)L_1} = \frac{89.02}{(20 - (2.5 - 1.8)0.6)}$$

$$L_2 = 2.13\text{m}$$

Provide (2.2 x 2.2)m footing.

Analysis of footing

$$q_{u1} = \frac{R_1 \times 1.5}{L_1 \times 1\text{m}} = \frac{60.98 \times 1.5}{2.4 \times 1.0} = 38.1125 \text{ t/m}$$

$$q_{u2} = \frac{R_2 \times 1.5}{L_2 \times 1\text{m}} = \frac{89.02 \times 1.5}{2.2 \times 1.0} = 60.695 \text{ t/m}$$

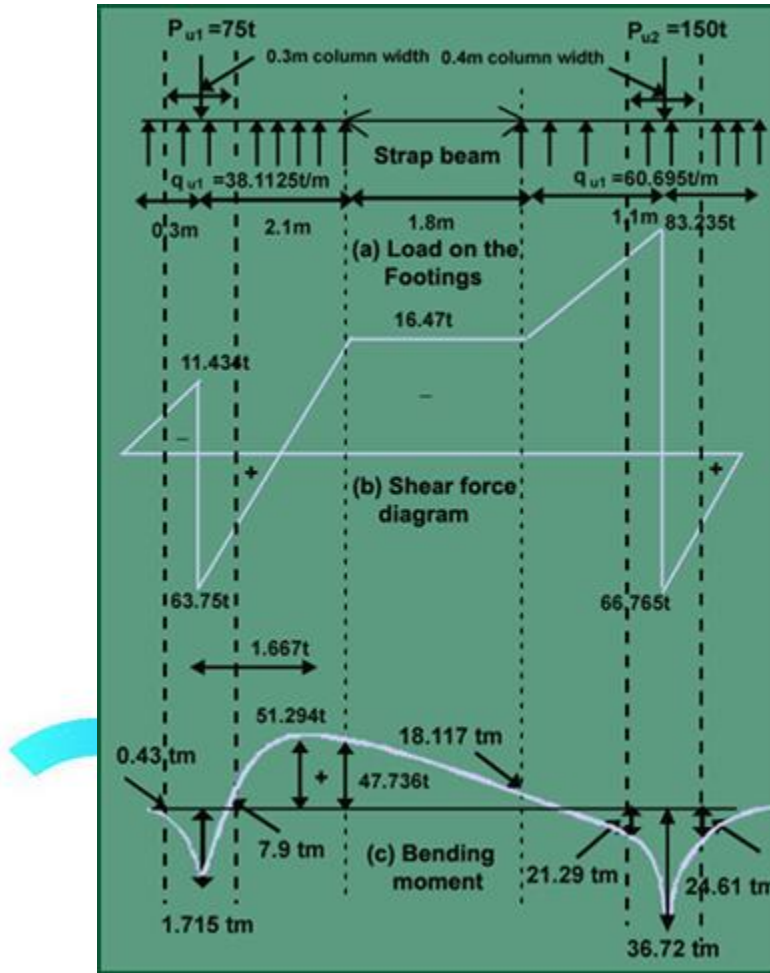

Fig. 4.38 Analysis of footing
 Thickness of footing i) Wide beam shear: For footing A:



Let us assume $P_t = 0.2\% B_1$ so from table 16 of IS456, $\tau_c = 0.32 \text{ N/mm}^2 = 32 \text{ t/m}^2$

Assume in direction of B_1 , width of strap beam (b) is 500 mm.

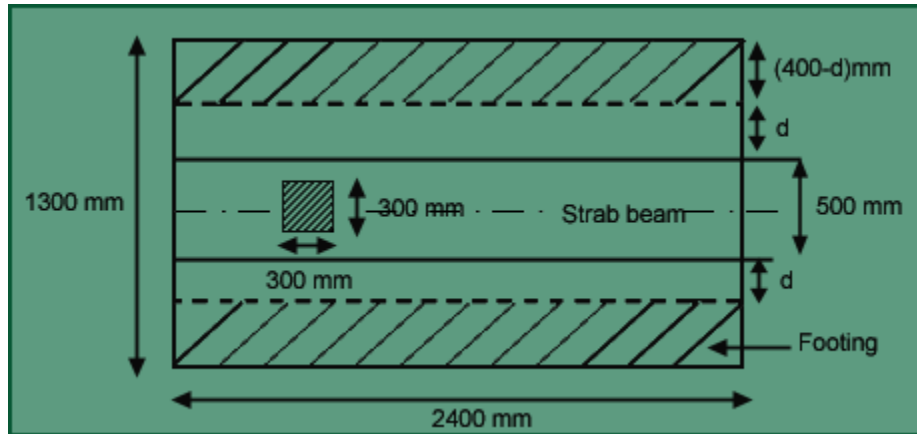

Fig. 4.39 Wide beam shear for footing A

$$\text{Shear} = b d \tau_c = q_u (0.4 - d)$$

$$\therefore (0.5) d (32) = (38.1125) (0.4 - d)$$

$$\therefore d = 0.282 \text{ m}$$

For footing B:

Let us assume $P_t (\%) = 0.2\%$, so from table 16 of IS456, $\tau_c = 0.32 \text{ N/mm}^2 = 32 \text{ t/m}^2$

Assume in direction of B_1 , width of strap beam (b) is 500 mm.

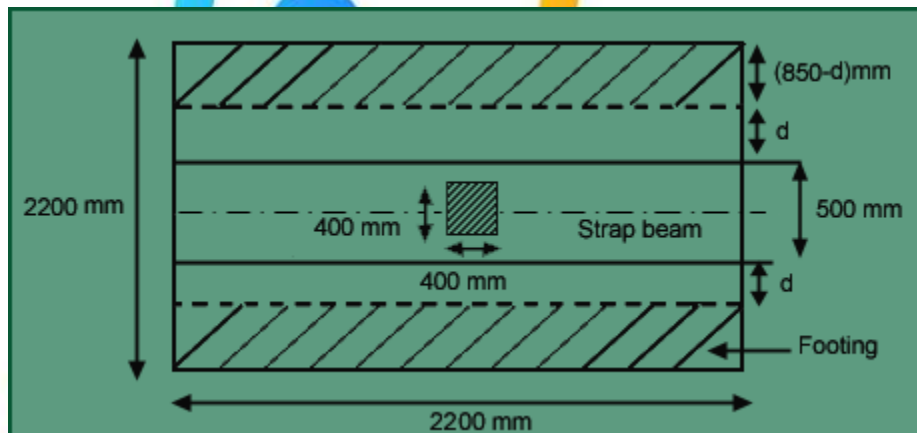

Fig. 4.40 Wide beam shear for footing B

$$\text{Shear} = b d \tau_c = q_u (0.4 - d)$$

$$\therefore (0.5) d (32) = (60.6955) (0.85 - d)$$

$$\therefore d = 0.673 \text{ m} > 600 \text{ mm depth earlier assumed.}$$

∴ Increasing the width of the beam to 700 mm

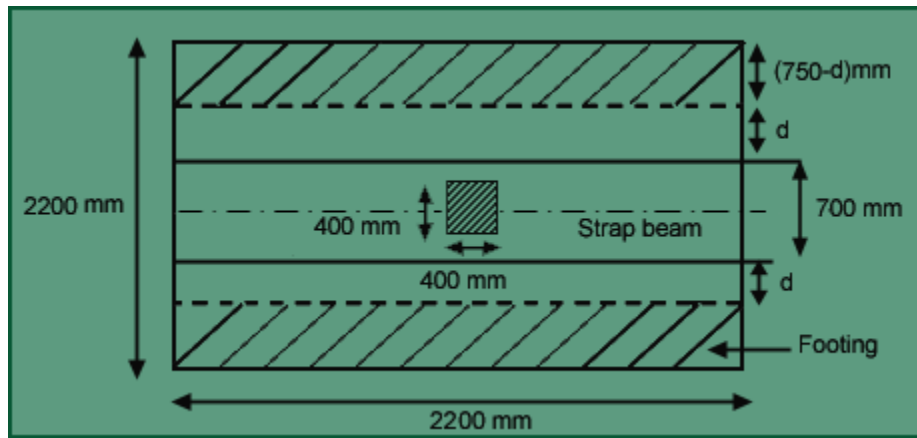

Fig. 4.41 Wide beam shear for footing B

Let us assume $P_t(\%) = 0.3\%$, so from table 16 of IS456, $\tau_c = 0.38 \text{ N/mm}^2 = 38 \text{ t/m}^2$

$$\text{Shear} = b d \tau_c = q_u (0.75 - d)$$

$$\therefore (0.7) d (38) = (60.6955) (0.75 - d)$$

$$\therefore d = 0.521 \text{ m} < 600 \text{ mm depth earlier assumed.}$$

∴ Safe

ii) Two way shear: For column A:

From clause 31.6.3.1 of IS456-2000.

$$\beta_c = \frac{\text{width of column}}{\text{length of column}} = \frac{300}{300} = 1.0$$

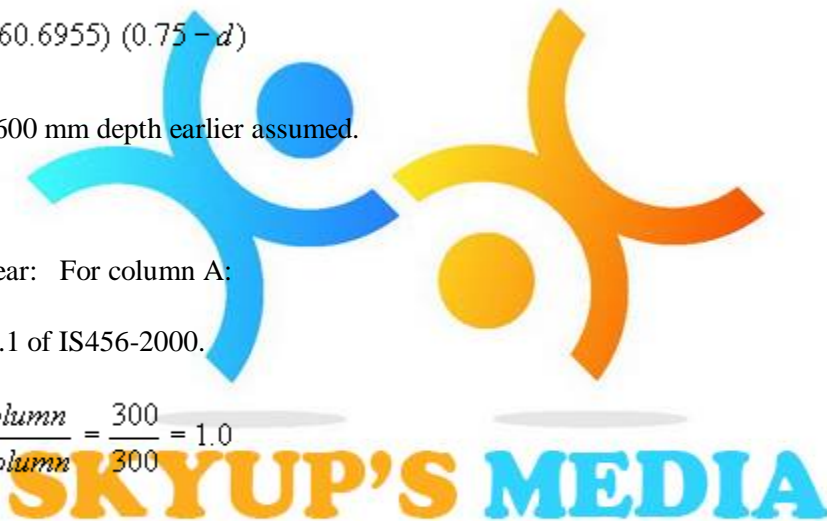

$$k_s = \beta_c + 0.5 = 1.5 \leq 1.0$$

$$\tau_c = k_s (0.25)\sqrt{fck} \text{ (N/mm}^2\text{)}$$

$$\tau_c = 1.0 (0.25)\sqrt{15} = 0.968 \text{ N/mm}^2 = 96.8 \text{ t/m}^2$$

Critical perimeter $\times d \times \tau_c = P_u - q_u \times$ (critical area – dotted area in fig. 4.42)

So, shear equation becomes,

Critical perimeter $\times d \times \tau_c = P_u - q_u \times$ (critical area – dotted area in fig. 4.42)

$$\therefore 2 (0.75+1.5d) d (96.8) = 75 - 38.1125 (0.3 + 0.15 + 0.5d)$$

$$\therefore 290.4 d^2 + 164.25 d - 57.85 = 0$$

$$d = 0.246 \text{ mm} < 600 \text{ mm.}$$

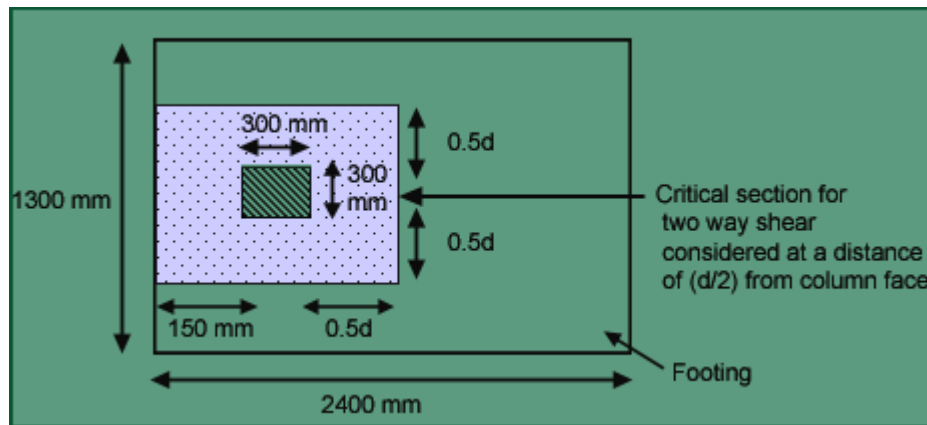

Fig. 4.42 Wide beam shear for footing A

For column B: From clause 31.6.3.1 of IS456-2000.

$$\beta_c = \frac{\text{width of column}}{\text{length of column}} = \frac{400}{400} = 1.0$$

$$k_s = \beta_c + 0.5 = 1.5 \leq 1.0$$

$$\tau_c = k_s (0.25)\sqrt{fck} \text{ (N/mm}^2\text{)}$$

$$\tau_c = 1.0 (0.25)\sqrt{15} = 0.968 \text{ N/mm}^2 = 96.8 \text{ t/m}^2$$

Critical perimeter = $2 (0.4+d+0.4+d) = 4 (0.4+d)$

So, shear equation becomes,

Critical perimeter $\times d \times \tau_c = P_u - q_u \times$ (critical area – dotted area in fig. 4.43)

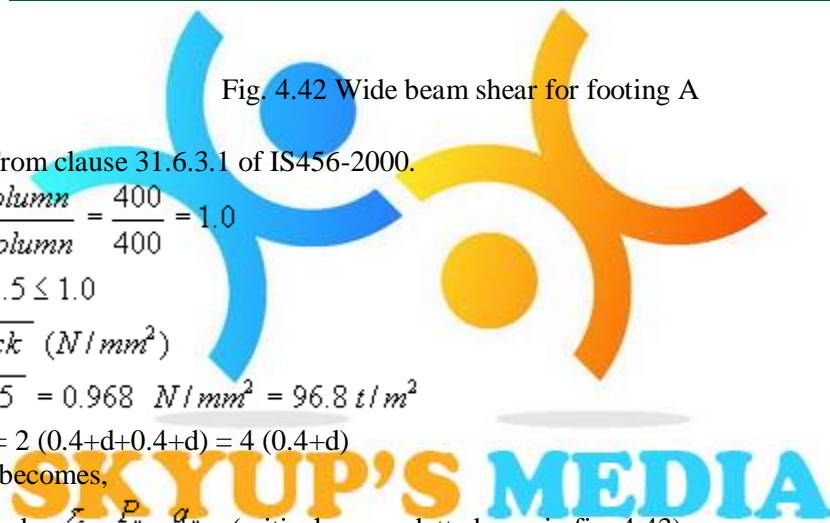

$$\therefore 2(0.4+d)d(96.8) = 150 - 60.6955(0.4+d)$$

$$\therefore 387.2d^2 + 215.58d - 125.72 = 0$$

$d = 0.355 \text{ mm} < 600 \text{ mm}$. Among all the required d values (for wide beam shear and two way shear criteria),

$$\text{Max. } d_{\text{required}} = 521 \text{ mm.}$$

$$\therefore D_{\text{required}} = 521 + (20/2) + 40 = 571 \text{ mm}$$

So, provide $D = 600 \text{ mm}$

$$\therefore d_{\text{provided}} = 550 \text{ mm}$$

Reinforcement for flexure for footings (i) Design along the length direction: Comparing the moments at the column faces in both the footings (A & B),

$$M_{\text{max}} = 24.61 \text{ tm (for Footing B)}$$

$$\frac{M_u}{bd^2} = \frac{24.61 \times 10^7}{10^3 \times (550)^2} = 0.813 \text{ N/mm}^2$$

From table 1 of SP-16, $P_t = 0.242\%$ (ii) Design along the width direction:

$$q_{u1} (=38.1125 \text{ t/m}) < q_{u2} (=60.695 \text{ t/m})$$

So, for design along width direction footing B (q_{u2}) is considered.

$$M_u = \frac{60.6955 \times (0.75)^2}{2} = 17.1 \text{ tm} < M_u \text{ in longer direction (24.61 tm)}$$

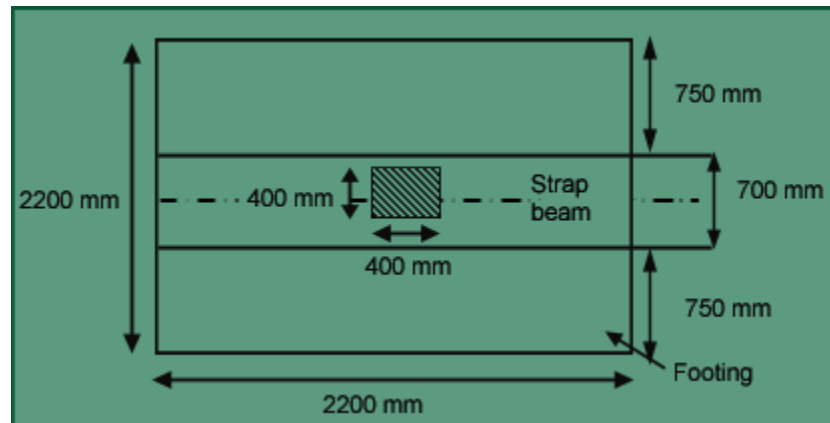

Fig. 4.44 Bending along the width of footing B

So, $P_t = 0.242\%$ i. e. same as reinforcement along longer direction.

But, From wide beam criteria $P_t = 0.3\%$,

$$\therefore A_{st}(\text{required}) = (0.3/100) \times (103) \times (550) = 1650 \text{ mm}^2.$$

\therefore Provide 20 Tor @ 175 c/c along both directions at bottom face of the footing A and B.

Design of strap beam (i) Reinforcement for flexure:

$$\frac{M_u^{\max}}{bd^2} = \frac{51.294 \text{ tm}}{700 \times (550)^2} = 2.43 \text{ N/mm}^2 \quad (\text{Refer fig. 4.45})$$

From table 49 of SP-16, $d'/d = 50/550 = 0.1$,

$$\therefore A_{st} = 0.83 \% \text{ and } P_c = 0.12 \%$$

$$\therefore A_x \text{ (required on tension face)} = (0.83/100) \times 700 \times 550 = 3195.5 \text{ mm}^2,$$

$$\therefore A_x \text{ (required on compression face)} = (0.12/100) \times 700 \times 550 = 462 \text{ mm}^2,$$

Provide (6+5=) 11 no.s Tor 20 at top of the strap beam and 4 no.s Tor 20 at bottom of the strap beam.

(ii) Check for shear:

$$V_{\max} = 83.235 \text{ t}$$

$$\tau_{\text{acting}} = \frac{V_{\max}}{bd} = \frac{83.235 \times 10^4}{700 \times 550} = 2.162 \text{ N/mm}^2 < \tau_{\text{max}} = 2.5 \text{ N/mm}^2 \text{ (for M15)}$$

$$P_t \text{ (provided)} = \frac{11 \times 314}{700 \times 550} \times 100 = 0.897\%$$

From table 61 of SP-16, $\tau_c = 0.57 \text{ N/mm}^2$

But, provide shear reinforcement for shear = $(\tau_{\text{acting}} - \tau_c) = 1.592 \text{ N/mm}^2 = V_{us}$

$$\frac{V_{us}}{d} = (\tau_{\text{acting}} - \tau_c)b = (1.592)(700) = 1114.4 \text{ N/mm} = 11.144 \text{ KN/cm}$$

From table 16 of SP-16, using 4L stirrups, $(V_{us}/d) = (11.144/2) = 5.572 \text{ KN/cm}$

∴ From table 62 of SP-16, provide 4L-stirrups 10 Tor @ 100 c/c near the column (upto distance of $d=550\text{mm}$ from column face) and 4L-stirrups 10 Tor @ 250 c/c for other portions.

Check for development length

From clause 25.2.1 of IS456-2000,

$$\text{Development length} = L_d = \frac{\phi \sigma_s}{4 \tau_{bd}} = \frac{20 \times 415}{4 \times 1 \times 1.6} = 1297 \text{ mm}$$

For column A:

$$\text{Length of the bar provided} = 150 - 40 = 110 \text{ mm} < L_d$$

∴ By providing 2 no.s 90° bend the extra length to be provided = $(1297 - 110 - 3(8 \times 20)) = 707 \text{ mm}$.

$$\text{In B direction length of the bar provided} = \frac{1300 - 300}{2} - 40 = 460 \text{ mm} < L_d$$

∴ Providing two 90° bend, the extra length to be provided = $(1297 - 460 - 2(8 \times 20)) = 517 \text{ mm}$.

(ii) Check for shear:

SKYUP'S MEDIA

$$V_{max} = 83.235 \text{ t} = \frac{83.235 \times 10^4}{700 \times 550} = 2.162 \text{ N/mm}^2$$

$$P_t = \frac{11 \times 314}{700 \times 550} \times 100 = 0.897\% < \text{max} = 2.5 \text{ N/mm}^2 \text{ (for M15)}$$

(provided) = $\frac{11 \times 314}{700 \times 550} = 0.897\%$

From table 61 of SP-16, $\sigma_{sc} = 0.57 \text{ N/mm}^2$

But, provide shear reinforcement for shear $= (V_{acting} - V_{us}) = 1.592 \text{ N/mm}^2 = V_{us}$

$$\frac{V_{us}}{d} = 11.144 \text{ N/mm} = 11.144 \text{ KN/cm}$$

From table 16 of SP-16, using 4L stirrups, $(V_{us}/d) = (11.144/2) = 5.572 \text{ KN/cm}$

From table 62 of SP-16, provide 4L-stirrups 10 Tor @ 100 c/c near the column (upto distance of d=550mm from column face) and 4L-stirrups 10 Tor @ 250 c/c for other portions.

■ Check for development length

From clause 25.2.1 of IS456-2000,

$$\text{Development length} = L_d = \frac{\phi \sigma_s}{4 \tau_{bd}} = \frac{20 \times 415}{4 \times 1 \times 1.6} = 1297 \text{ mm}$$

For column A:

Length of the bar provided = $150 - 40 = 110 \text{ mm} < L_d$

∴ By providing 2 no.s 90° bend the extra length to be provided = $(1297 - 110 - 3(8 \times 20)) = 707 \text{ mm}$.

$$\frac{1300 - 300}{2} - 40 = 460 \text{ mm} < L_d$$

In B direction length of the bar provided =

∴ Providing two 90° bend, the extra length to be provided = $(1297 - 460 - 2(8 \times 20)) = 517 \text{ mm}$.

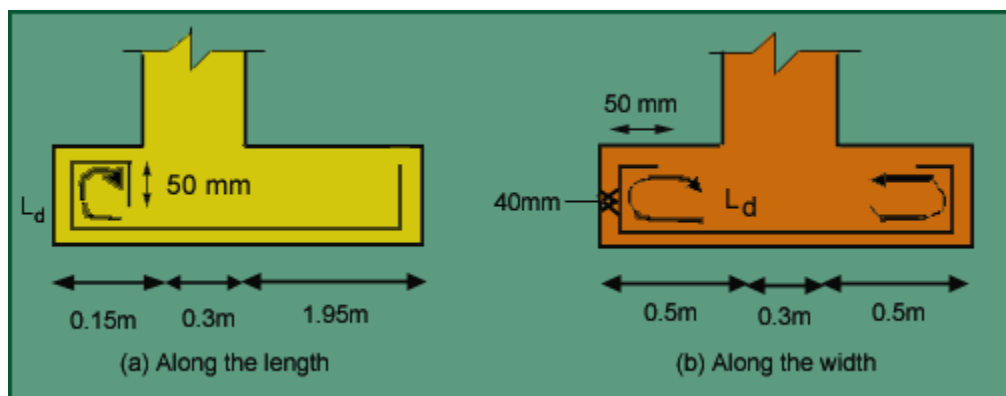

Fig. 4.45 Development length for footing A

For column B:

Length of the bar provided = $\frac{2200 - 400}{2} - 40 = 860 \text{ mm} < L_d$
 Providing one 90° bend, the extra length to be provided = $(1297 - 860 - (8 \times 20)) = 277 \text{ mm}$.

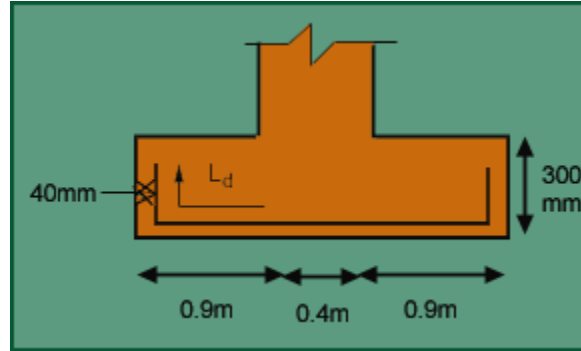

Fig. 4.46 Development length for footing B (Along the length and width)

Transfer of load at base of the column: For footing A:

From clause 34.4 of IS456-2000, permissible bearing stress (q_{per}) = $\sqrt{\frac{A_1}{A_2}} (0.45 f_{ck})$

$$A_1 = (150 + 300 + 1200)(1300) = 2145000 \text{ mm}^2$$

$$A_2 = (300 \times 300) = 90000 \text{ mm}^2$$

$$\therefore \sqrt{\frac{A_1}{A_2}} = 4.88 \leq 2$$

$$\therefore \sqrt{\frac{A_1}{A_2}} = 2$$

$$q_{per} = 2 \times 0.45 \times 1500 = 1161 \text{ t/m}^2$$

$$q_{acting} = (\text{load on column}/\text{area of column}) = (1.5 \times 50)/(0.3)^2 = 833.3 \text{ t/m}^2 < q_{per} \therefore \text{Safe.}$$

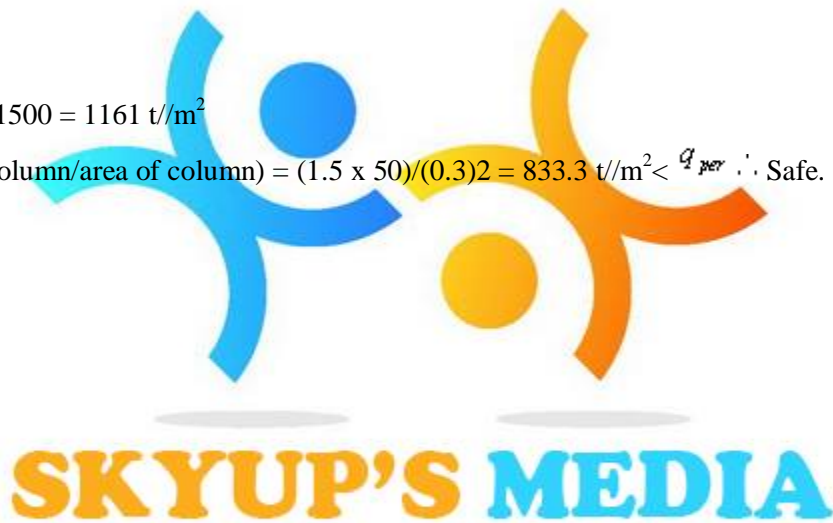

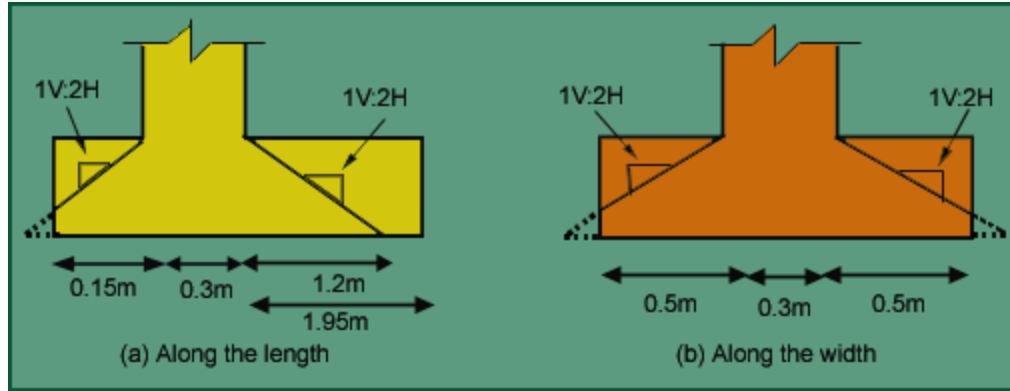

Fig. 4.47 Area of footing A considered for check of transfer of load at column base

For Footing B: From clause 34.4 of IS456-2000, permissible bearing stress (q_{per}) = $\sqrt{\frac{A_1}{A_2}} (0.45 f_{ck})$

$$A_1 = (2200)^2 = 4840000 \text{ mm}^2$$

$$A_2 = (400 \times 400) = 160000 \text{ mm}^2$$

$$\therefore \sqrt{\frac{A_1}{A_2}} = 5.5 \leq 2$$

$$\therefore \sqrt{\frac{A_1}{A_2}} = 2$$

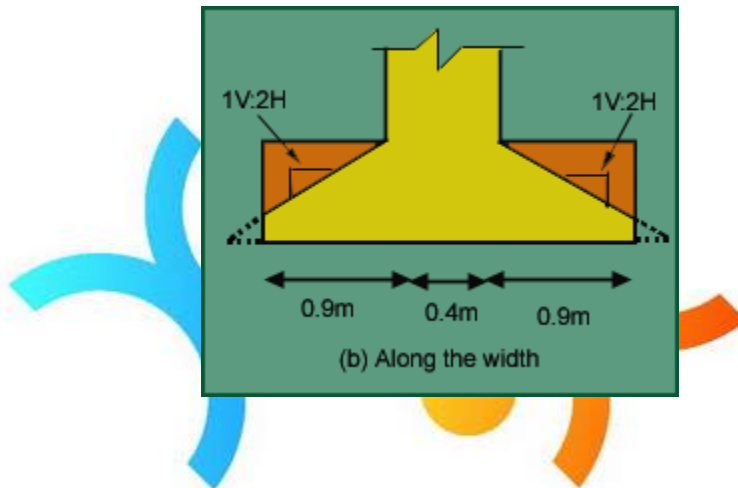

Fig. 4.48 Area of footing B considered for check of transfer of load at column base

$$q_{per} = 2 \times 0.45 \times 1500 = 1161 \text{ t/m}^2$$

$$q_{acting} = (\text{load on column}/\text{area of column})$$

$$= (1.5 \times 100)/(0.4)^2$$

$$= 937.5 \text{ t/m}^2 < q_{per}$$



UNIT III FOOTINGS AND RAFTS

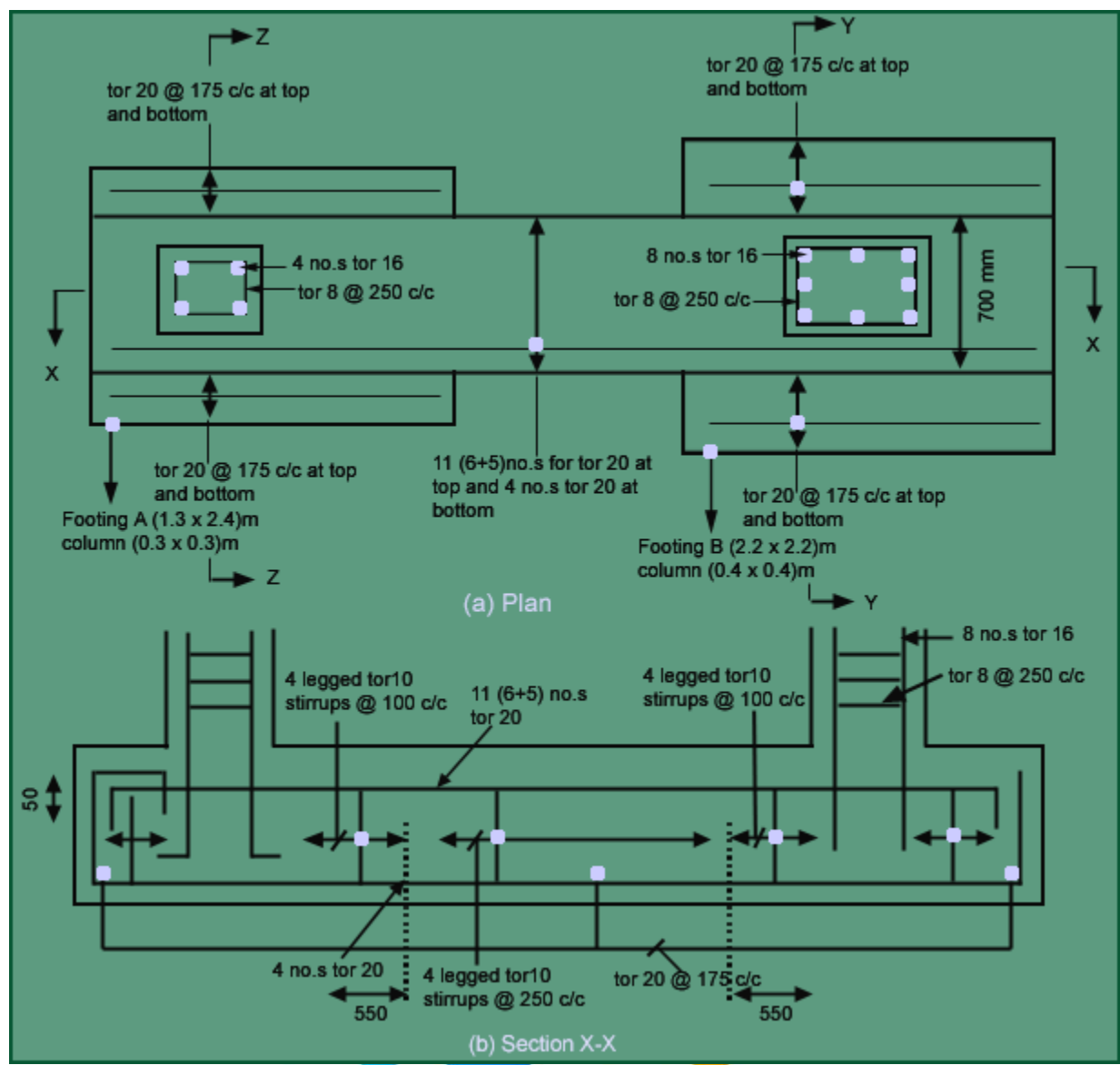

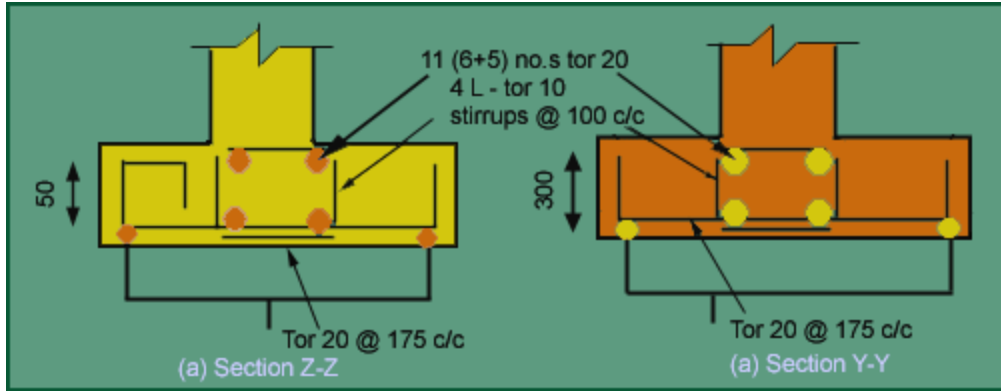

Design of Combined

Footing

$$P_1 = 800 \text{ kN}$$

$$P_2 = 1000 \text{ kN}$$

$$q_a = 20 \text{ t/m}^2, M15, f_y = 415 \text{ kN/m}^2$$

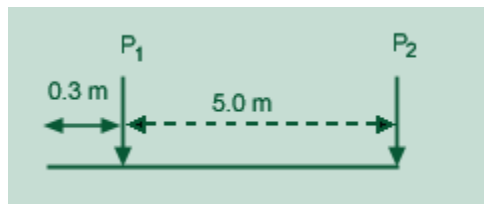

Fig. 4.51 Loading on combined footing

Column size: 400x400mm.

See Fig 4.54 for details of footing. ■ **Column design**

Let $p_t = 0.8\%$

$$A_x = .008A; A_v = 0.992A$$

Clause.39.3 of IS 456-2000

$$A = 146763.8 \text{ mm}^2$$

$$A_x = 1174.11 \text{ mm}^2, A_v = 145589.746 \text{ mm}^2$$

Provide footing of 400x400 size for both columns.

Using 8-16 ϕ as main reinforcement and 8 ϕ @ 250c/c as lateral tie

Design of Footing



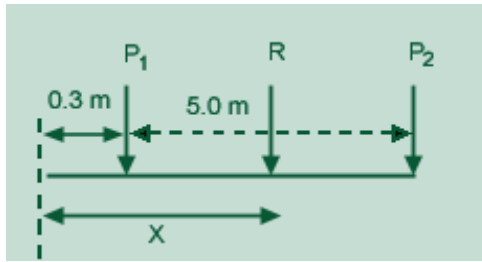

Fig. 4.52 Forces acting on the footing

Resultant of Column Load

$R = 1800 \text{ kN}$ acting 3.08m from the boundary.

Area of the footing :

Taking length $L=6\text{m}$, Depth of footing $D_f=0.9\text{m}$, $\gamma_c = 2.5\text{t/m}^2$, $\gamma_s = 1.8\text{t/m}^2$

Width of footing,
$$B = \frac{P_1 + P_2}{L[q_u - (\gamma_c - \gamma_s)D_f]} = 1.549\text{m}.$$

Therefore, provide footing of dimension $6\text{m} \times 1.6\text{m}$

Soil Pressure $q = \frac{180}{6 \times 1.6} = 18.75 \text{ t/m}^2 < 20 \text{ t/m}^2 \text{ OK}.$

$q_u = 28.125 \text{ t/m}^2$

Soil pressure intensity acting along the length $= B \times q_u = 1.6 \times 28.125 = 45\text{t/m}.$

$R_B = 119.88\text{kN}$, $R_C = 150.12\text{kN}.$

Thickness of Footing i. Wide beam shear:

Maximum shear force is on footing C, $SF=115.02\text{KN}$

$\tau_c \times B \times d = qu[2.556 - 0.2 - d]$

$\tau_c = 0.32\text{N/mm}^2$ for percentage reinforcement $F_t=0.2\%$

$0.32 \times d \times 1.6 = 45 [2.556 - 0.2 - d]$

$d=1.1\text{m}$

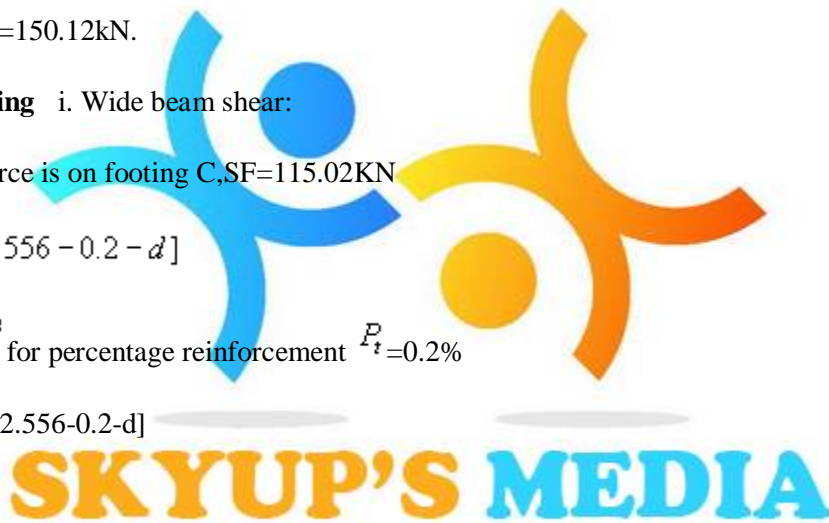

$$\tau_c = 0.5 N/mm^2 \text{ for percentage reinforcement } P_t = 0.6\%$$

$$0.6 \times d \times 1.6 = 45 [2.556 - 0.2 - d]$$

$$d = 0.847m, D = 900mm, OK.$$

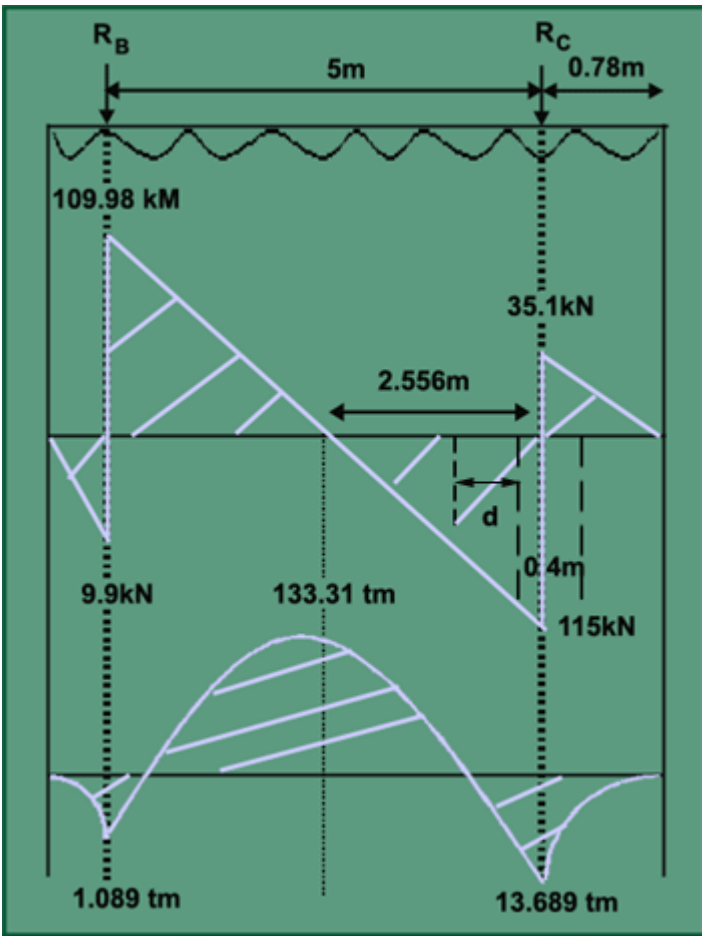

ii. Two way Shear beam shear:

Thickness of Footing i. Wide

Maximum shear force is on footing C, SF=115.02KN

$$\tau_c \times B \times d = qu [2.556 - 0.2 - d]$$

$$\tau_c = 0.32 N/mm^2 \text{ for percentage reinforcement } P_t = 0.2\%$$

$$0.32 \times d \times 1.6 = 45 [2.556 - 0.2 - d]$$

$$d = 1.1m$$

$$\tau_c = 0.5 N/mm^2 \text{ for percentage reinforcement } P_t = 0.6\%$$

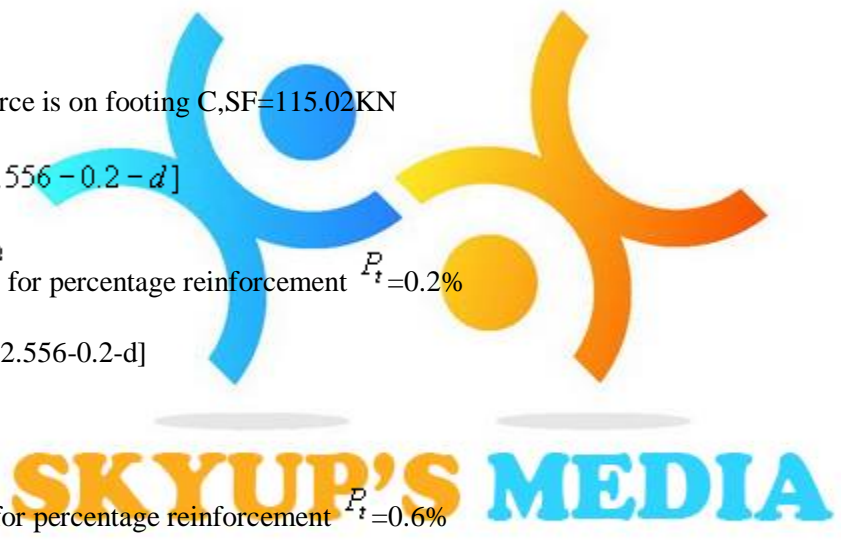

$$0.6 \times d \times 1.6 = 45 [2.556 - 0.2 - d]$$

$$d = 0.847 \text{ m}, D = 900 \text{ mm. OK.}$$

$$\beta_c = 1, k_s = 1.5 \Rightarrow 1,$$

$$\text{ii. Two way Shear } \tau_c' = k_s \tau_c = 96.8 \text{ t/m}^2$$

Column B

$$4(0.4 + d)d \times 96.8 = 150 - 28.125(0.4 + d)^2$$

$$d = 0.415 \text{ m.}$$

Column A

$$2d[(0.4 + d) + (0.42 + d/2)] \times 96.8 = 120 - 28.125[(0.4 + d)(0.42 + d/2)]$$

$$d = 0.3906 \text{ m}$$

$$d_{\text{reqd}} = 0.85 \text{ m}$$

$$D_{\text{provided}} = 900 \text{ mm}, d_{\text{reqd}} = 850 \text{ mm. OK.}$$

■ Flexural reinforcement

Along Length Direction

$$\frac{M_u}{bd^2} = \frac{133.31 \times 10^4}{1.6 \times 850^2} = 1.15 \text{ N/mm}^2$$

Table 1 of SP16

$$P_t = 0.354\%$$

$$P_t \text{ provided} = 0.6\%$$

$$A_{st} \text{ required} = 5100 \text{ mm}^2/\text{m}$$

Provide 28 ϕ @ 120 mm/c at top and bottom of the footing

Along width direction

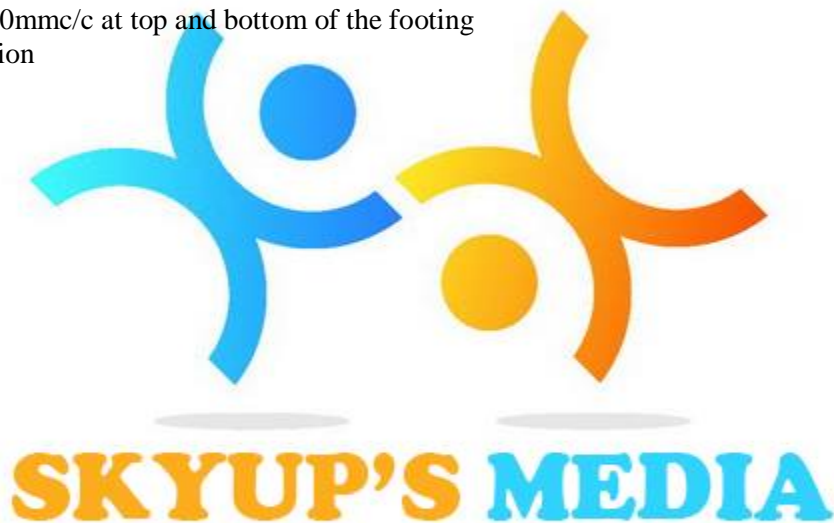

$$M_u = \frac{28.125 \times 1.6^2}{2} = 36tm$$

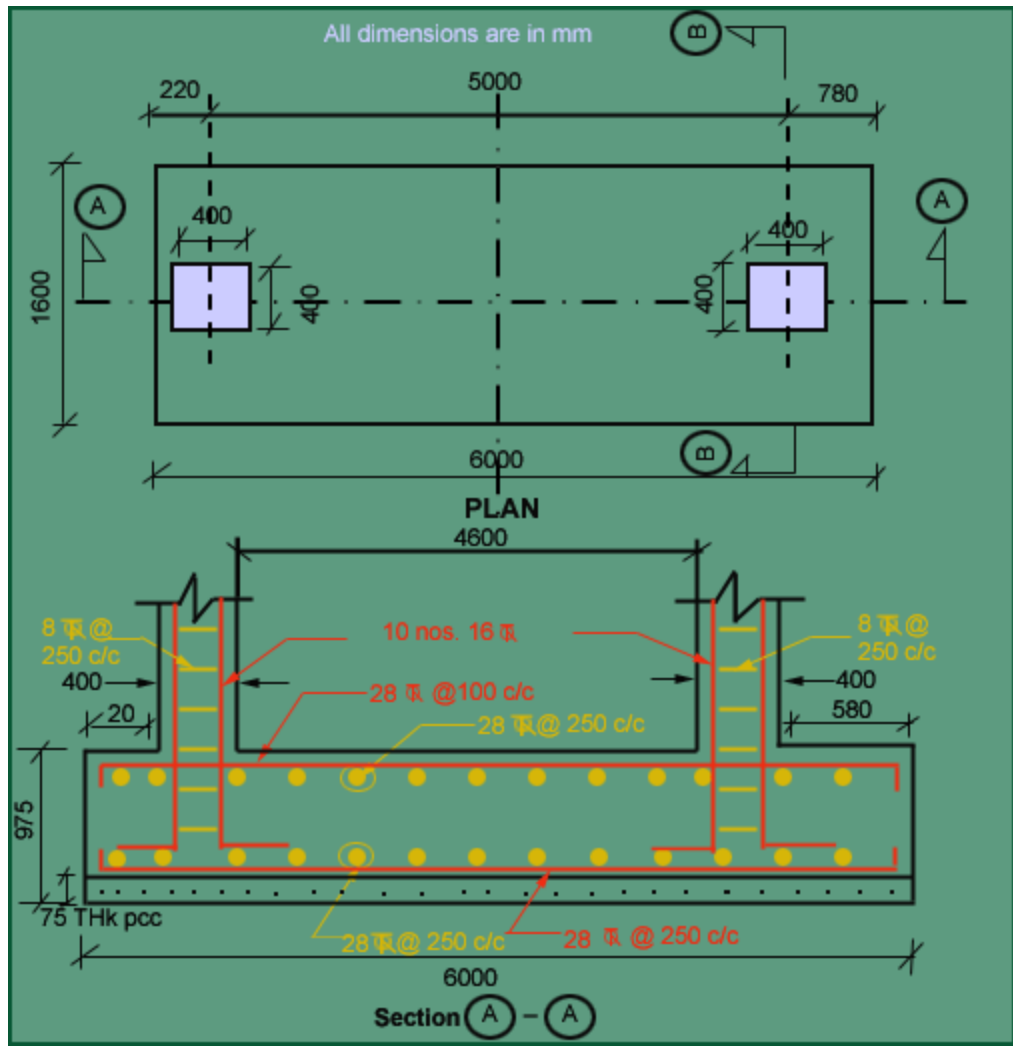

$$M_u = 0.073 N / mm^2$$



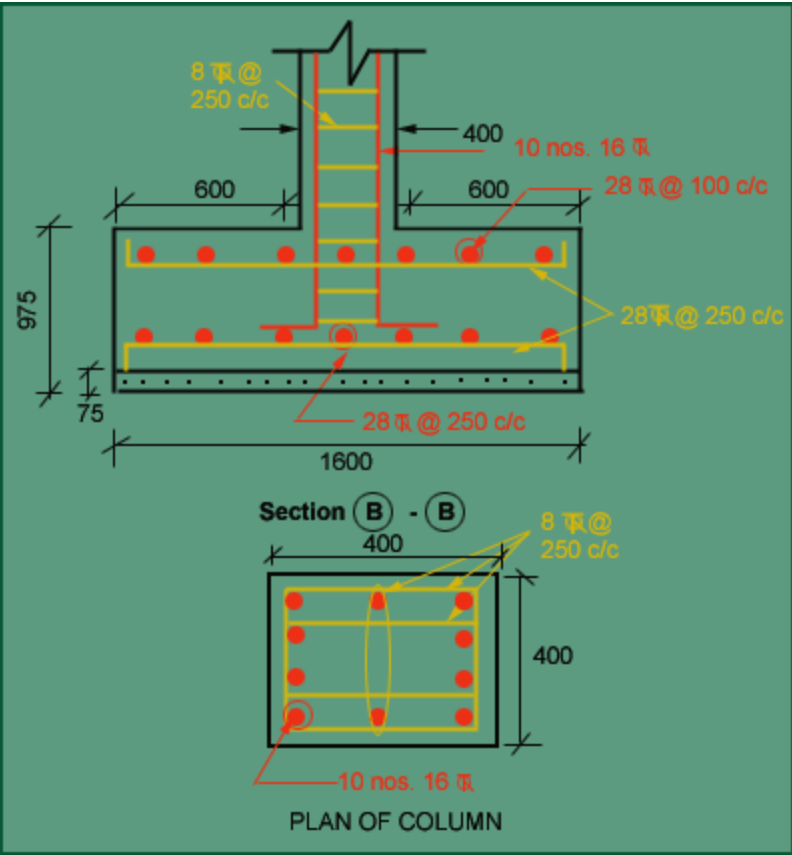

Raft Footing Design the raft footing for the given loads on the columns and spacing between the columns as shown below.

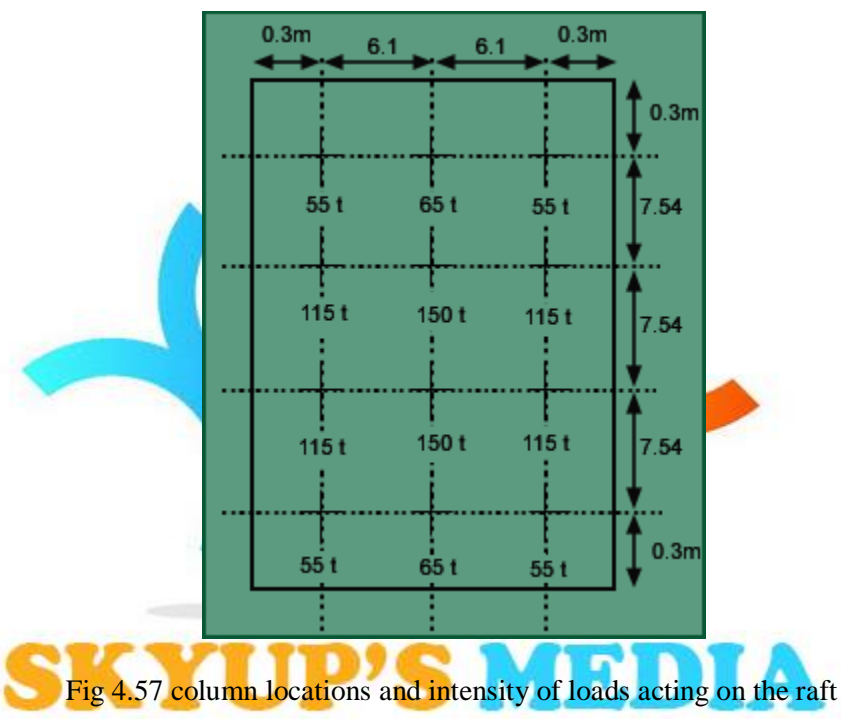

a) Column sizes

Fig 4.57 column locations and intensity of loads acting on the raft

Take size of the columns are as: 300*450 mm for load of less than 115 ton

450*450 mm for a load of greater than 115 ton

Thickness of raft

$$q_{us} = \frac{1110}{12.8 \times 23.22} * 1.5 = 5.607 \text{ t/m}^2$$

Two way shear

The shear should be checked for every column, but in this case because of symmetry property checking for 115 t, 150 t, and 55 t is enough.

For 150 t column

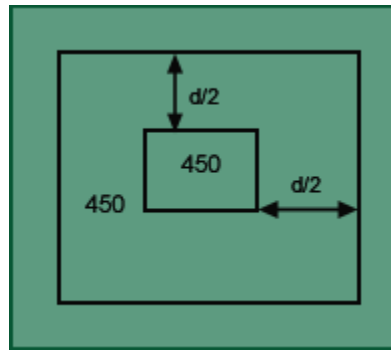

Fig 4.58 section for two way shear for 150 t column

IS: 456-1978, $\beta_c = 450/450 = 1.0$

$$K_s = (0.5 + \beta_c) = 1.0 = 1.0$$

Therefore $K_s = 1.0$

$$\tau_c = 0.25 \sqrt{f_{ck}} = 96.8 \text{ t/m}^2$$

$$\tau'_c = k_s \tau_c = 96.8 \text{ t/m}^2$$

$$f'_c = 96.8 \text{ t/m}^2$$

$$4(0.45 + d) * d * 96.8 = 150 * 1.5 - 5.607(0.45 + d)^2$$

Therefore $d = 0.562 \text{ m}$

For 115 t column



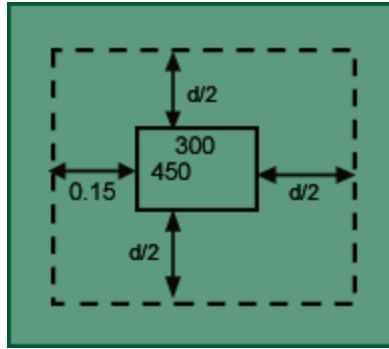

Fig 4.59 section for two way shear for 115 t column

$$2(0.45+d+0.15+0.3+d/2) d \cdot 96.8 = 115 \cdot 1.5 - 5.607(0.45+d)(0.3+0.15+0.5d)$$

Therefore $d=0.519$ m

For 55 t column

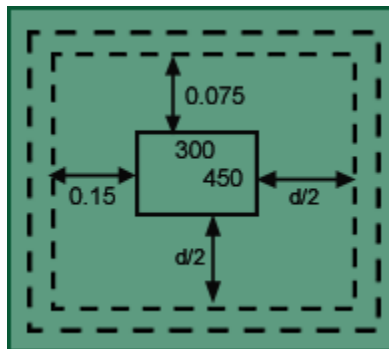

Fig 4.60 section for two way shear for 55 t column

$$2(0.45+0.075+0.5d+0.15+0.3+0.5d) d \cdot 96.8 = 55 \cdot 1.5 - 5.607(0.45+0.5d+0.075)(0.3+0.5d+0.15)$$

Therefore $d=0.32$ m

The guiding thickness is 0.562m and code says that the minimum thickness should not be less than 1.0m.

let provide a overall depth of 1.1m=D

$$d_{prov} = 1100 - 75 - 20/2 = 1015 \text{ mm.}$$

To calculate k & λ -Stiffness factors

There are two criterions for checking the rigidity of the footing:

Plate size used is 300*300 mm.

For clays: $\lambda = 0.5$,

$$k = B \frac{E_s}{1 - \mu_s^2}$$

Take $k=0.7$ and $B=30$ cm

$E_s=15.75 \text{ kg/cm}^2=1.575 \text{ N/mm}^2$

$$K = \frac{EI}{E_s b^3 a}, \quad \text{where } I = \frac{ad^3}{12}$$

$$E = 5000 \sqrt{f_{ck}}$$

$$= 5000 \sqrt{15} = 19364.92 \text{ N/mm}^2$$

$b=23.2 \times 10^3$ mm, $a=12.8 \times 10^3$ mm, $d=1015$ mm

$$K = \frac{19364.92 \times 1015^3 \times 12.8 \times 10^3}{12 \times 1.575 \times (23.2 \times 10^3)^3 \times 12.8 \times 10^3}$$

$$= 0.085 < 0.5$$

Therefore it is acting as a flexible footing.

$$\lambda = \left(\frac{kB}{4E_c I} \right)^{\frac{1}{4}} = \frac{0.7 \times 12.8 \times 10^2 \times 12}{4 \times 19364.92 \times 12.8 \times 10^2 \times 101.5^3}$$

$$= 0.00179 \times 10^{-3}$$

$$1.75 / \lambda = 975.184 = 9.75 \text{ m}$$

If column spacing is less than $1.75 / \lambda$, then the footing is said to be rigid.

Therefore the given footing is rigid.

One criterion showing the footing is flexible and another showing that the given footing is rigid. Both are contradicting each other, so design the footing for both criteria.

$$q_{act} = \frac{1100}{12.8 \times 23.2} = 3.738 \text{ t/m}^2$$

$$q_{us} = 5.607 \text{ t/m}^2$$

$$q = \frac{2 \times 510 + 645}{6.1 + 6.1 + 0.6} = 130.08 \text{ t/m}^2$$



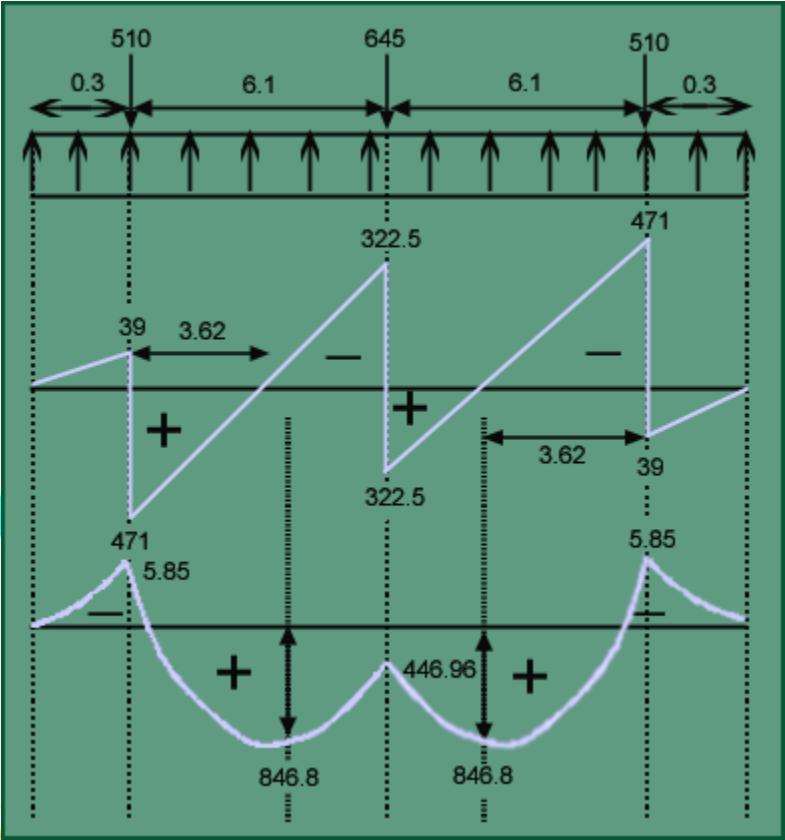
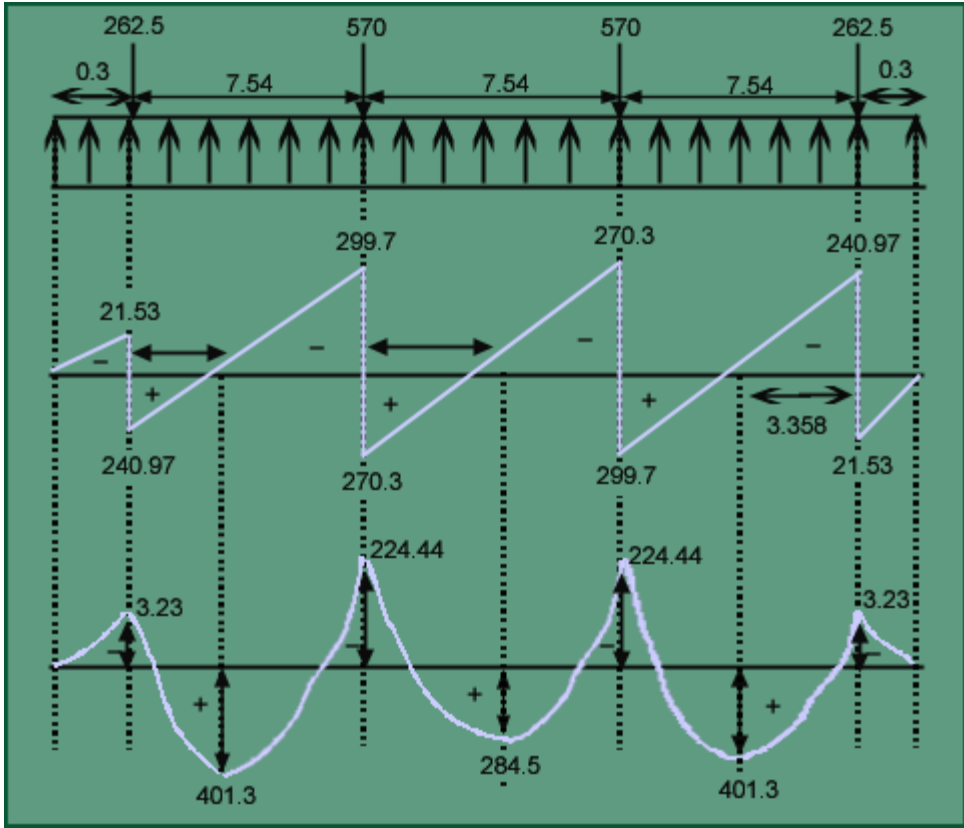

Reinforcement in width direction

$$\frac{M_u}{b d_x^2} = \frac{846.8 \times 10^7}{23.2 \times 10^3 * 1015^2} = 0.354$$

From SP-16 graphs

$$P_t = 0.102\%, \text{ but minimum is } 0.12\%.$$

$$A_{st} = (0.12 * 1000 * 1015) / 100 = 1218 \text{ mm}^2$$

Provide 20 mm diameter bars @250 c/c along shorter direction in bottom.

❖ Reinforcement in length direction

$$\frac{M_u}{b d_y^2} = \frac{401.3 \times 10^7}{12.8 \times 10^3 * (1015 - 20)^2} = 0.316$$

Provide 20 mm diameter bars @250 c/c in longer direction.

Clause 33.3.1

$$A_{st \text{ central band}} = \frac{2}{\frac{23.2}{12.8} + 1} (1218 * 23.2) \text{ mm}^2$$

Provide 20 mm diameter bars @ 200 c/c in central band and 20 mm diameter bars @300 c/c at other parts along shorter direction at bottom.

Shear (wide beam shear criterion)

In width direction

$$\frac{V_u}{b d_x} = \frac{471 \times 10^4}{23.2 \times 10^3 * 1015} = 0.2 \text{ N/mm}^2 < \tau_v$$

$$P_t \text{ prov} = 0.123\%,$$

$$\tau_c = 0.27 \text{ N/mm}^2 > \tau_v \text{ (from table 61 of SP - 16 by extrapolation)}$$

Therefore no shear reinforcement is required.

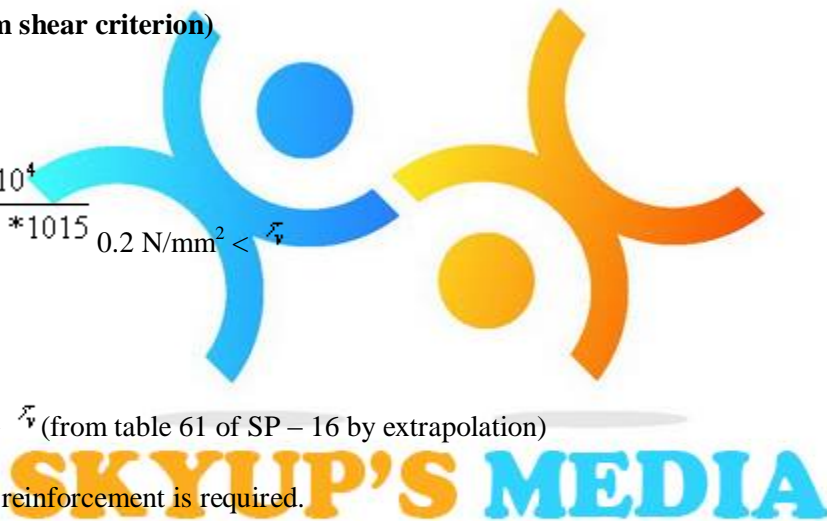

$$\frac{V_u}{b d_y} = \frac{229.7 \times 10^4}{12.8 \times 10^3 * (1013 - 20)} = 0.235 \text{ N/mm}^2 < \tau_c (0.27 \text{ N/mm}^2)$$

Therefore no shear reinforcement is required.

Along the width direction

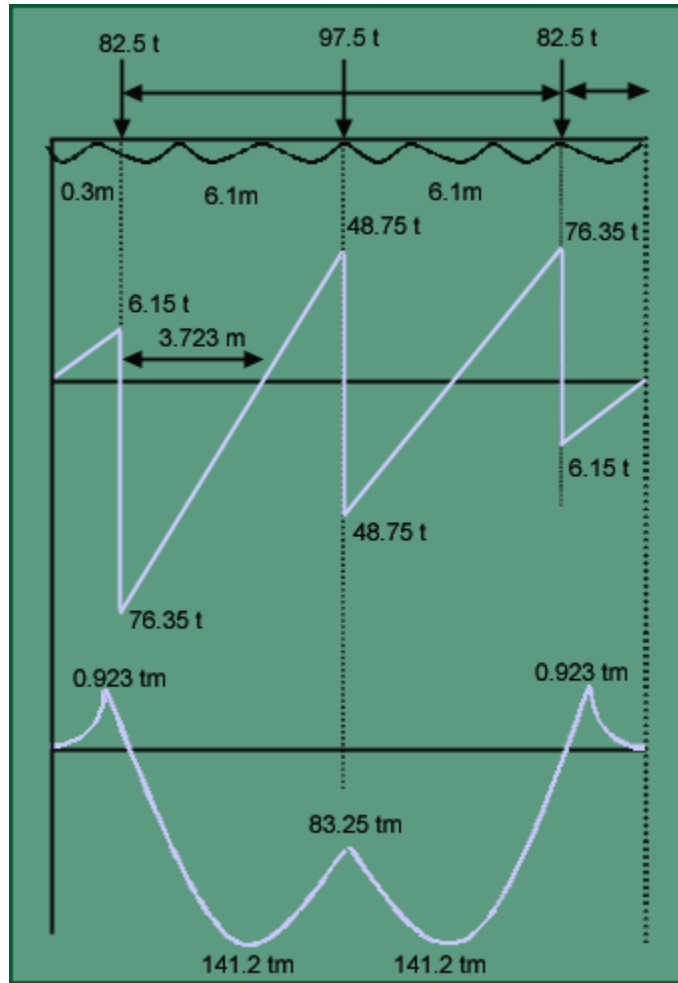

Fig. 4.63 Shear Force and Bending Moment Diagrams of strips 1 and 4

In width direction: Strip1/4:-

$$M_u = 141.2 \text{ tm}$$

$$\frac{M_u}{b d^2} = \frac{141.2 \times 10^7}{4.067 \times 10^3 \times (1015)^2} = 0.337 \text{ N/mm}^2$$

Strip2/3

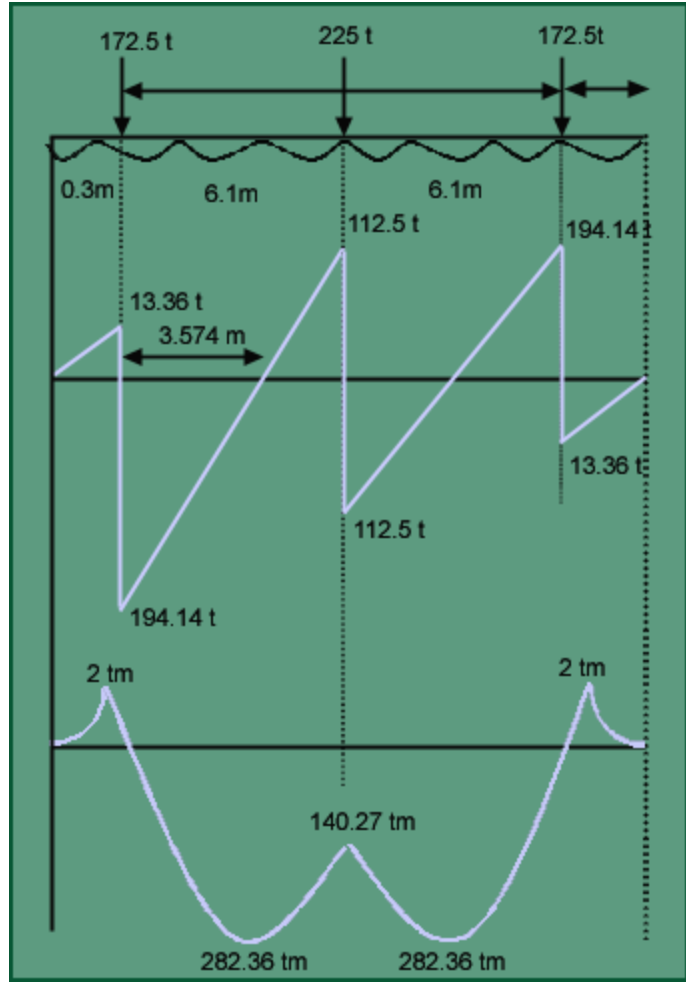

Fig. 4.64 Shear Force and Bending Moment Diagrams of strips 2 and 3

Strip 2/3

$$M_u = 282.36 \text{ tm}$$

$$\frac{M_u}{bd^2} = \frac{282.36 \times 10^7}{7.533 \times 10^3 \times (1015)^2} = 0.364 \text{ N/mm}^2$$

Minimum $F_t = 0.12\%$ has to be provided.

Provide 20 ϕ @ 200c/c in centre band and 20 ϕ @ 300c/c at other parts along the shorter direction.

1. Shear check

Along width direction:-

For strip 1/4:



$$V_u = 76.35t$$

$$\frac{V_u}{bd_x} = \frac{76.35 \times 10^4}{4.067 \times 10^3 \times 1015} = 0.185 \text{ N/mm}^2 < \tau_c, \text{ OK.}$$

For strip 2/3:

$$V_u = 159.14t$$

$$\frac{V_u}{bd_x} = \frac{159.14 \times 10^4}{7.533 \times 10^3 \times 1015} = 0.208 \text{ N/mm}^2 < \tau_c, \text{ OK.}$$

Hence no shear reinforcement is required.

Development Length

$$L_d = \frac{\phi \sigma_s}{4 \lambda b d} = \frac{20 \times 0.87 \times 415}{4 \times 1 \times 1.6} = 1128.3 \text{ mm}$$

At the ends, length of bar provided = 150 mm.

Extra length to be provided = 1128.3 - 150 - 8 \times 20 = 818.3 mm.

Provide a Development length of 850 mm

3. Transfer of load at the base of the column:-

For end column;

$$A_1 = 2650 \times 2725 = 7.22125 \times 10^6 \text{ mm}^2$$

$$A_2 = 300 \times 450 = 135000 \text{ mm}^2$$

$$\sqrt{\frac{A_1}{A_2}} = 7.31 \text{ But not greater than } 2.0$$

$$q_{perm} = \sqrt{\frac{A_1}{A_2}} \times 0.45 f_{ck} = 13.5 \text{ N/mm}^2$$

$$q_{acting} = \frac{55 \times 10^4}{300 \times 450} = 4.07 \text{ N/mm}^2 < q_{perm}, \text{ OK.}$$

For 150t columns

$$q_{acting} = \frac{150 \times 10^4}{450^2} = 7.41 \text{ N/mm}^2 < q_{perm}, \text{ OK.}$$

For 115t columns

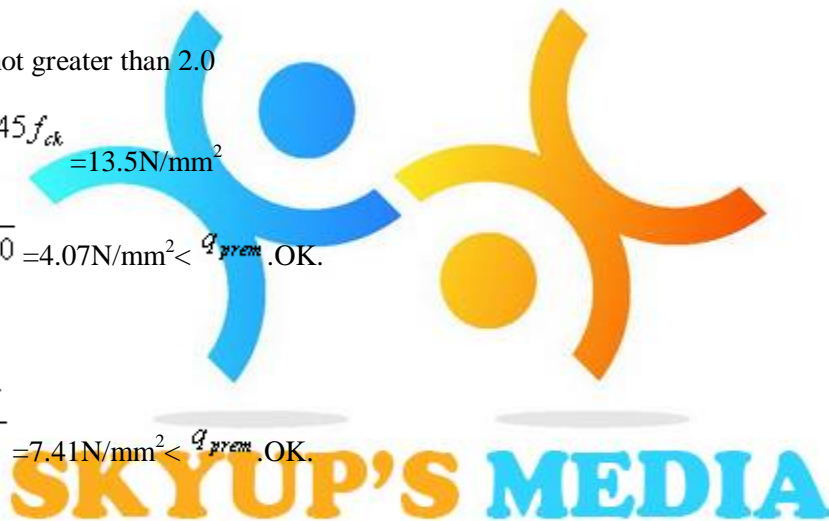

$$\sqrt{\frac{A1}{A2}} = 2, \quad q_{acting} = \frac{115 \times 10^4}{300 \times 450} = 8.52 \text{ N/mm}^2 < q_{perm}. \text{OK.}$$



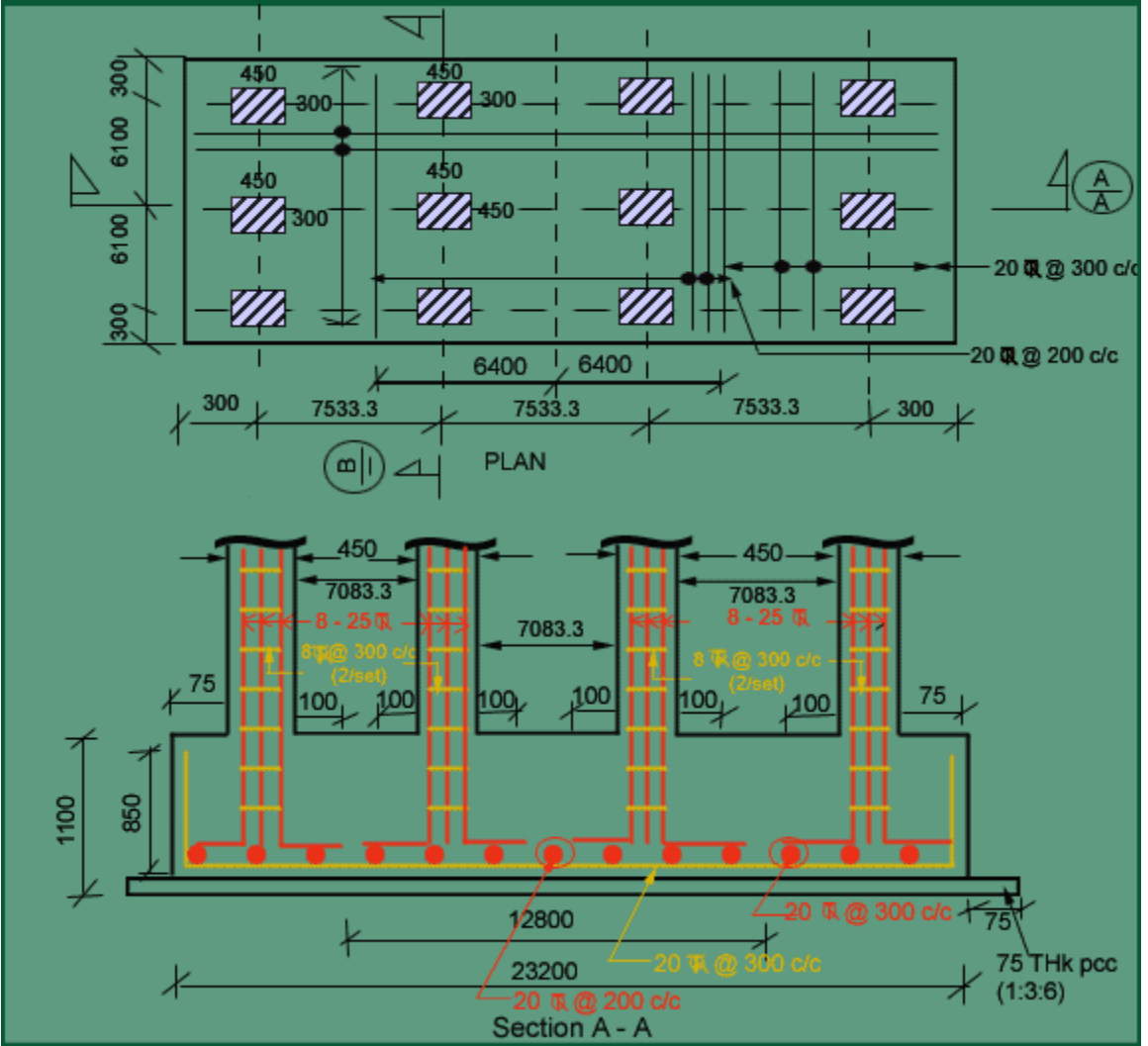
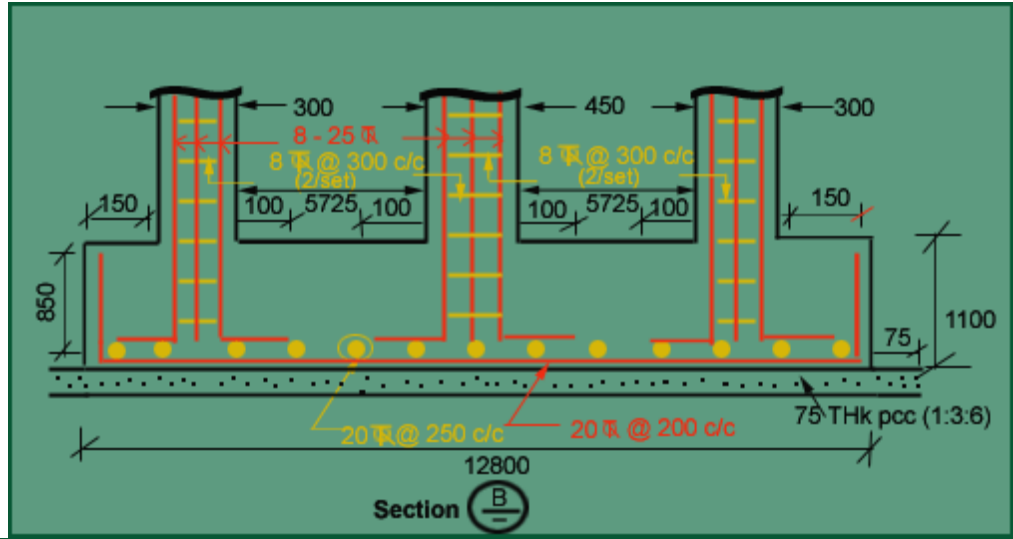

SKYUP'S MEDIA

UNIT IV PILES

DESIGN METHODOLOGY FOR PILES The detailed design methodology of piles is described in the following sections.

REQUIREMENT FOR DEEP FOUNDATIONS Generally for structures with load $>10 \text{ t/m}^2$, we go for deep foundations. Deep foundations are used in the following cases:

- Huge vertical load with respect to soil capacity.
- Very weak soil or problematic soil.
- Huge lateral loads eg. Tower, chimneys.
- Scour depth criteria.
- For fills having very large depth.
- Uplift situations (expansive zones)
- Urban areas for future large and huge construction near the existing building.

CLASSIFICATION OF PILES 1. Based on material

- Timber piles
 - Steel piles
 - Concrete piles
 - Composite piles (steel + concrete)
2. Based on method of installation
- Driven piles ----(i) precast (ii) cast-in-situ.
 - Bored piles.
3. Based on the degree of disturbance
- Large displacement piles (occurs for driven piles)
 - Small displacement piles (occurs for bored piles)

POINTS TO BE CONSIDERED FOR CHOOSING PILES

- Loose cohesion less soil develops much greater shaft bearing capacities if driven large displacement piles are used.
- Displacement effect enhanced by tapered shafts.
- Potential increased of shaft capacities is undesirable if negative friction is to be feared. (Negative friction is also called drag down force)
- High displacement piles are undesirable in stiff cohesive soils, otherwise excessive heaving takes place.
- Encountered with high artesian pressures on cased piles should be excluded. (Mainly for bridges and underwater construction)
- Driven piles are undesirable due to noise, damage caused by vibration, ground heaving.
- Heavy structures with large reactions require high capacity piles and small diameter cast-in-situ piles are inadequate.
- **PILE CLASSIFICATION**
- Friction piles.
- End bearing piles.
- Compaction piles.(Used for ground movement, not for load bearing)

- Tension piles/Anchored piles.(To resist upliftment)
- Butter piles (Inclined) --- +ve and -ve.

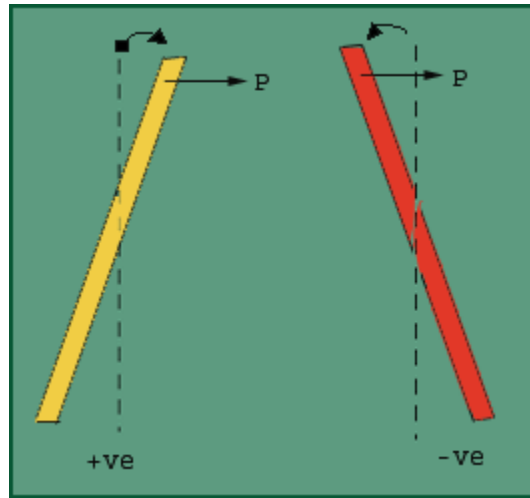

Fig. 5.1 Direction of load is same as the direction of batter. (Rotation of pile)

Raymond piles. (Driven cast-in-situ piles, first tapered shell is driven and then cast)

Franki Piles (Driven cast-in-situ piles, first casing is driven upto 2m depth, then cast a block within that casing and then drive the block. When it reaches the particular depth, take out the casing and cast the piles.)

Underreamed piles (bored cast-in-situ piles, bulbs used, hence not possible to install in loose sand and very soft clays.)

PILES IN CLAY Zone of influence

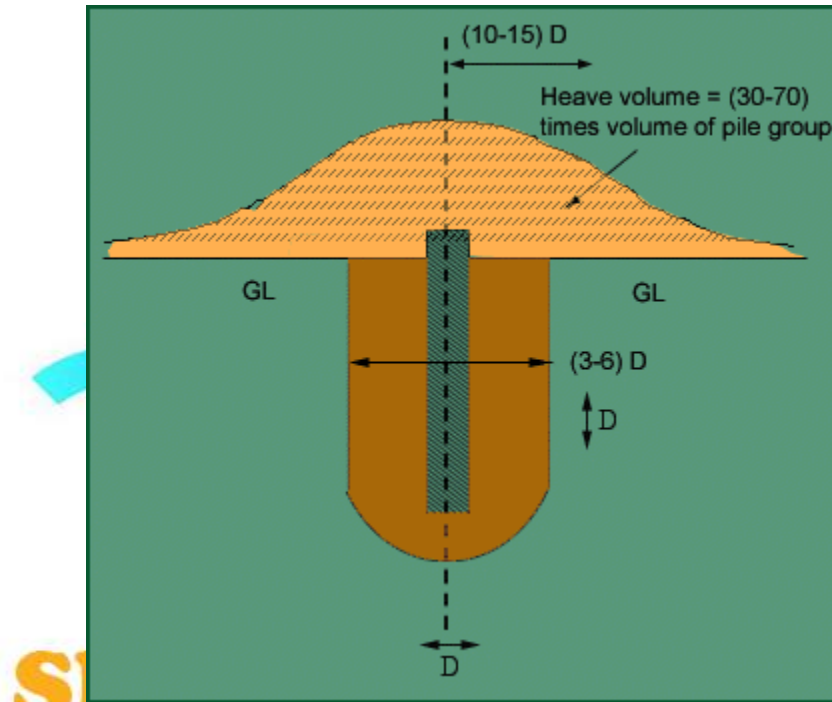

Fig.5.2 Driven piles in clay

The heaving effect can be felt upto $(10 - 15) D$ from the centerline of the pile. Due to driving load, pressure is generated and as a result heaving occurs. Afterwards with time, the heaved part gets consolidated and strength gradually increases as the material regains shear strength within 3 – 6 months time after the installation of the pile. This regain of strength is called thixotropy.

On the first day some part of the pile will be driven and on the second day some part of the pile may move up due to the gain of shear strength. This is known as the *wakening of the pile*. By the driving force, the extra pore pressure generated is $(5 - 7)$ times the C_u of the soil. Bearing capacity of the pile is $9 C_u$. Hence due to this property, maximum single length of the pile theoretically can be upto 25m but 10-12m is cast at a time. Then by splicing technique the required hired length of the pile is obtained. Special types of collars are used so that the splices become weak points. Concrete below the grade M20 is never used.

Pile Diameter	Maximum length (m)
250	12
300	15
350	18
400	21
450	25

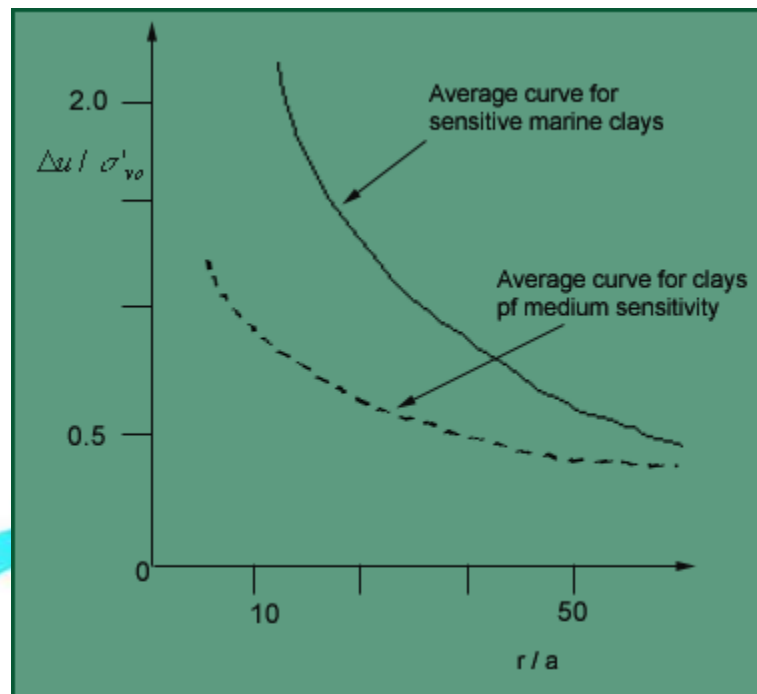
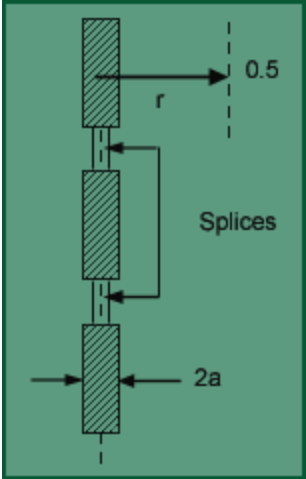

Fig.5.3 Generation of



PILES IN SAND

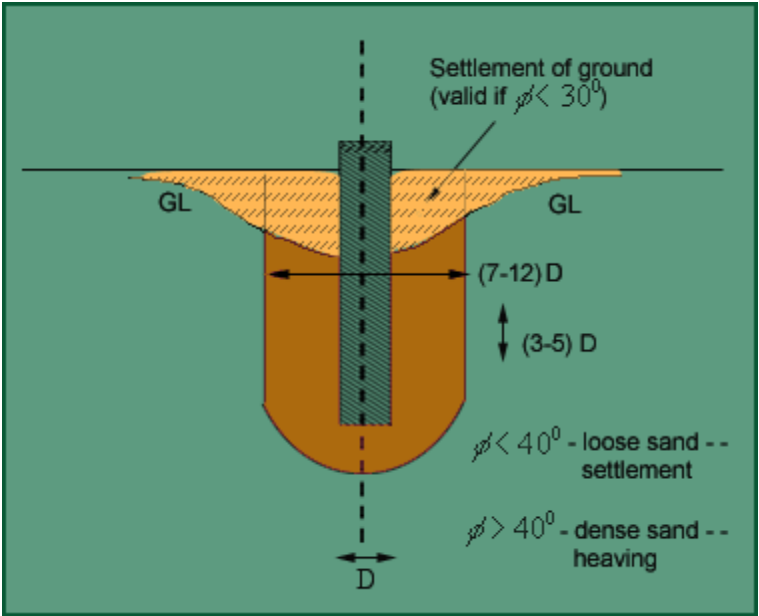

Fig.5.4a Driven piles in loose sand



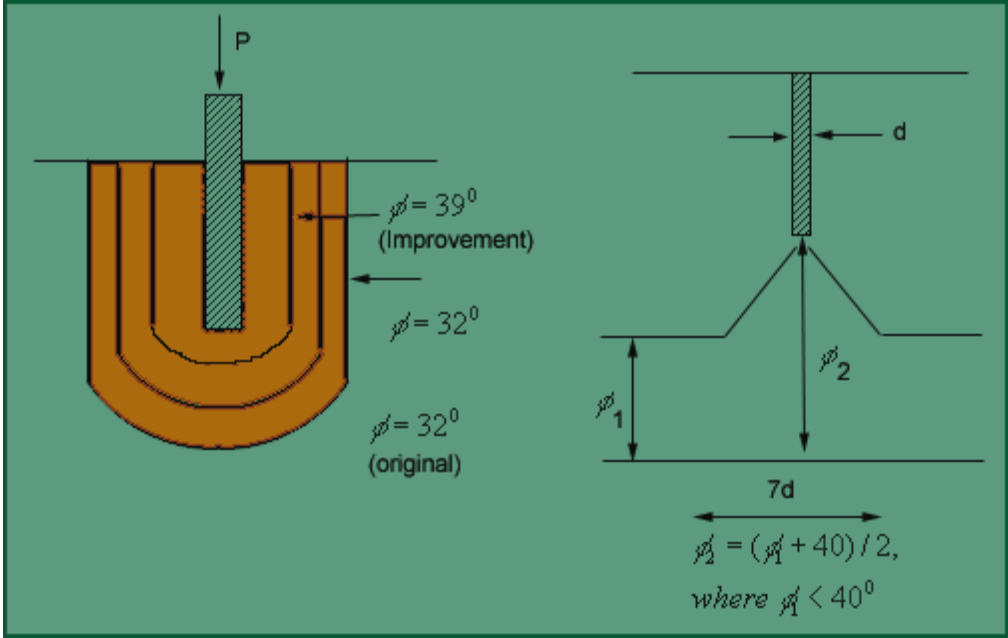

Fig.5.4b Improvement in f due to pile driving

SETTLEMENT OF PILE GROUPS

Assume 2V:1H dispersion for settlement of pile groups.

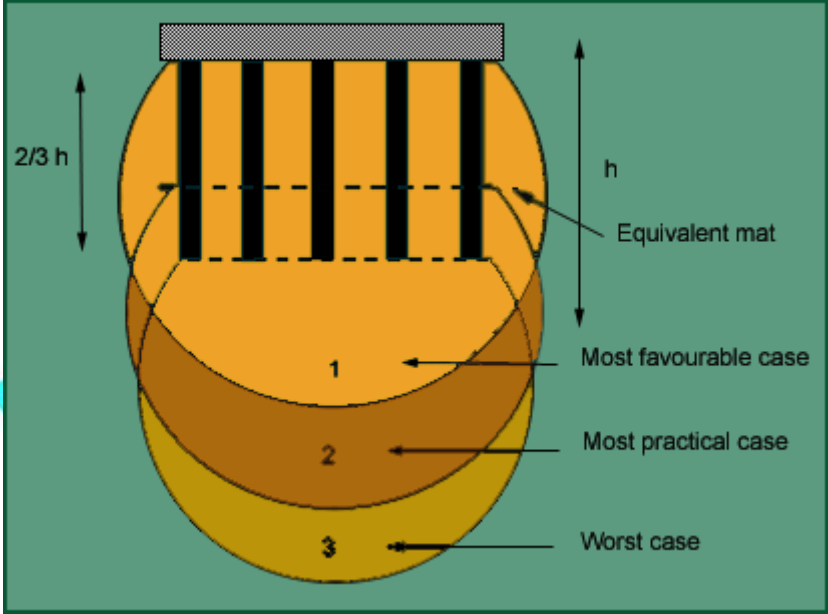

Fig.5.5 Settlement of pile groups

CODAL PROVISION SAFE LOAD ON PILES/PILE GROUPS (Ref. IS: 2911 Part IV 1979) Single pile:

1. Safe load = Least of the following loads obtained from routine tests on piles :

- 2/3 of the final load at which total settlement is 12mm.
- 50% of the final load at which settlement is 10% of the pile dia.(for uniform dia. piles) and 7.5% of bulb dia. (for Underreamed piles)
- 2/3 of the final load at which net settlement is 6mm.
- Consider pile as column and find the total compressive load depending on the grade of concrete and dimensions. Eg. Consider a 300mm dia pile made of M20 concrete. $\sigma_{cc} = 5N/mm^2$.

Therefore, ultimate load = $\frac{\pi}{4} \times 300^2 \times 5 = 353.4KN$

Fig 5.40 Multiple Under Reamed Pile

Under reamed piles are bored cast-in-situ concrete piles having **one or more** number of **bulbs formed** by enlarging the pile stem. These piles are best suited in soils where considerable **ground** movements occur due to seasonal variations, filled up grounds or in soft soil strata. Provision of under reamed bulbs has the advantage of increasing the bearing and uplift capacities. It also provides better anchorage at greater depths. These piles are efficiently used in machine foundations, over bridges, electrical transmission tower foundation sand water tanks. Indian Standard IS 2911 (Part III) - 1980 covers the design and construction of under reamed piles having one or more bulbs. According to the code the diameter of under reamed bulbs may vary from 2 to 3 times the stem diameter depending upon the feasibility of construction and design requirements. The code suggests a spacing of 1.25 to 1.5 times the bulb diameter for the bulbs. An angle of 45° with horizontal is recommended for all under reamed bulbs. This code also gives Mathematical expressions for calculating the bearing and uplift capacities.

From the review of the studies pertaining to under reamed piles, it can be seen that ultimate bearing capacity of piles increases considerably on provision of under- reamed bulbs (Neumann and P&g, 1955, Subash Chandra and Kheppar, 1964, Patnakar, 1970 etc.). Pile load capacity was found to vary with the number of bulbs and with the spacing ratio S / D_u or S/d adopted (where S = distance between the piles, D_u = diameter of under reamed bulbs and d = diameter of piles). Table summarizes the various recommendations made for the selection of S / D_u and S/d for the optimum pile load capacity. It can be seen that some of these recommendations differ from those given in IS 2911 (Part III), 1980.

Table: 5.6 of recommendations for S / D_u and S/d for the optimum pile load capacity

Recommendations of S / D_u & S/d values for under reamed piles			
s.no.	Reference	No. of Bulbs	Spacing
1.	Patnakar (1970)	Pile capacity for one bulb increases 25 percent, for two bulbs 600 percent, and for three bulbs 700 percent over simple pile.	For optimum capacity two bulbs $S / D_u = 6$ or $S/d = 15$, for three bulbs, $S / D_u = 5$ or $S/d = 12$.
2	Agarwal and Jain (1971)	-	For optimum capacity $S / D_u = 1.25$ to 1.5
3	Sonapal and	-	For optimum capacity

	Thakkar (1977)		$S / D_u = 2.5$
4	IS 2911(Part III 1980)	More than two bulbs are not advisable	$S / D_u = 1.25$ to 1.5
5	Ray and Raymond (1983)	-	Maximum value of $S / D_u = 1.24$ to 1.5

The choice of an under-reamed pile in unstable or water-bearing ground is generally to be avoided. There is a danger of collapse of the under-ream, either when personnel are down the hole, or during concreting.

Important Notes: On the basis of limited experimental studies conducted on model under reamed piles in cohesion less soil the following conclusions are drawn.

1. By providing under reamed bulbs the ultimate load capacities of piles increases significantly. 2. The ultimate load bearing capacities of the under reamed piles with angle of under reamed bulbs of 45° and zero are almost same. 3. Three or more under reamed bulbs are advantageous only when the spacing ratio (S / D_u) is two or less, and when (S / D_u) is greater than two, multi-under reamed piles do not have specific advantages. 4. The ultimate load bearing capacities of piles are maximum when the spacing between two under reamed bulb is 2.5 times the diameter of the under reamed bulb. It appears that the spacing between two under reamed bulbs suggested in (1.25 to 1.5 times) IS 2911(1980) is not the optimum, 5. The expression suggested in IS 2911(1980) can be used for predicting the ultimate load carrying capacity of under reamed piles with spacing ratio (S / D_u) less than



UNIT V RETAINING WALLS

RETAINING WALL

2.5. Retaining walls are structures used to retain earth or water or other materials such as coal, ore, etc; where conditions do not permit the mass to assume its natural slope. The retaining material is usually termed as backfill. The main function of retaining walls is to stabilize hillsides and control erosion. When roadway construction is necessary over rugged terrain with steep slopes, retaining walls can help to reduce the grades of roads and the land alongside the road. Some road projects lack available land beside the travel way, requiring construction right along the toe of a slope. In these cases extensive grading may not be possible and retaining walls become necessary to allow for safe construction and acceptable slope conditions for adjacent land uses. Where soils are unstable, slopes are quite steep, or heavy runoff is present, retaining walls help to stem erosion. Excessive runoff can undermine roadways and structures, and controlling sediment runoff is a major environmental and water quality consideration in road and bridge projects. In these situations, building retaining walls, rather than grading excessively, reduces vegetation removal and reduces erosion caused by runoff. In turn, the vegetation serves to stabilize the soil and filter out sediments and pollutants before they enter the water source, thus improving water quality.

In this section you will learn the following

Gravity walls

Semi Gravity Retaining Wall

Flexible walls

Special type of retaining walls

Different Types of Retaining Structures On the basis of attaining stability, the retaining structures are classified into following: 1. **Gravity walls** :

Gravity walls are stabilized by their mass. They are constructed of dense, heavy materials such as concrete and stone masonry and are usually reinforced. Some gravity walls do use mortar, relying solely on their weight to stay in place, as in the case of dry stone walls. They are economical for only small heights.



. Semi Gravity Retaining Wall

SKYUP'S MEDIA

These walls generally are trapezoidal in section. This type of wall is constructed in concrete and derives its stability from its weight. A small amount of reinforcement is provided for reducing the mass of the concrete. This can be classified into two:

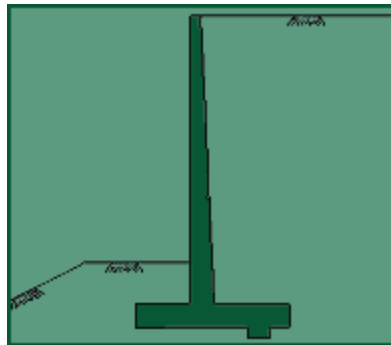

- Cantilever retaining wall
- Counter fort retaining wall

Cantilever retaining wall

Fig 6.3. Semi Gravity Retaining Wall

This is a reinforced concrete wall which utilises cantilever action to retain the backfill. This type is suitable for retaining backfill to moderate heights (4m-7m). In cross section most cantilevered walls look like “L”s or inverted “T”s. To ensure stability, they are built on solid foundations with the base tied to the vertical portion of the wall with reinforcement rods. The base is then backfilled to counteract forward pressure on the vertical portion of the wall. The cantilevered base is reinforced and is designed to prevent uplifting at the heel of the base, making the wall strong and stable. Local building codes, frost penetration levels and soil qualities determine the foundation and structural requirements of taller cantilevered walls. Reinforced concrete cantilevered walls sometimes have a batter. They can be faced with stone, brick, or simulated veneers. Their front faces can also be surfaced with a variety of textures. Reinforced Concrete Cantilevered Walls are built using forms. When the use of forms is not desired, Reinforced Concrete Block Cantilevered Walls are another option. Where foundation soils are poor, Earth Tieback Retaining Walls are another choice. These walls are counterbalanced not only by a large base but also by a series of horizontal bars or strips extending out perpendicularly from the vertical surface into the slope. The bars or strips, sometimes called “deadmen” are made of wood, metal, or synthetic materials such as geotextiles. Once an earth tieback retaining wall is backfilled, the weight and friction of the fill against the horizontal members anchors the structure.

Counterfort retaining wall

When the height of the cantilever retaining wall is more than about 7m, it is economical to provide vertical bracing system known as counter forts. In this case, both base slab and face of wall span horizontally between the counter forts.



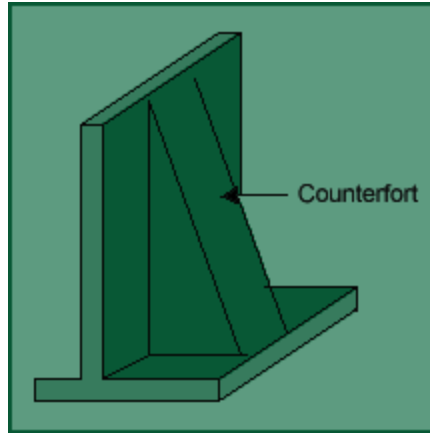

Fig. 6.5 Counter fort retaining wall

3. **Flexible walls:** there are two classes of flexible walls.

A.

Sheet pile walls and

B.

Diaphragm wall A. **Sheet Pile Walls** Sheet piles are generally made of steel or timber. The use of timber piles is generally limited to temporary structures in which the depth of driving does not exceed 3m. for permanent structures and for depth of driving greater than 3m, steel piles are most suitable. Moreover, steel piles are relatively water tight and can be extracted if required and reused. However, the cost of sheet steel piles is generally more than that of timber piles. Reinforced cement concrete piles are generally used when these are to be jetted into fine sand or driven in very soft soils, such as peat. For tougher soils, the concrete piles generally break off. Based on its structural form and loading system, sheet pile walls can be classified into 2 types:(i)Cantilever Sheet Piles and(ii)Anchored Sheet Piles 1. **Cantilever sheet pile walls:**

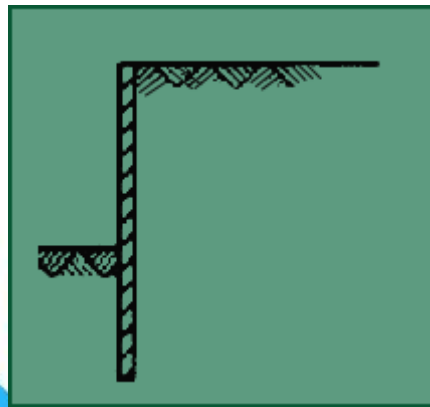

Fig. 6.6.Cantilever sheet pile wall

Cantilever sheet piles are further divide into two types:

■ **Free cantilever sheet pile** It is a sheet pile subjected to a concentrated horizontal load at its top. There is no back fill above the dredge level. The free cantilever sheet pile derives its stability entirely from the lateral passive resistance of the soil below the dredge level into which it is driven.

Cantilever Sheet Pile Wall with Backfill

A cantilever sheet pile retains backfill at a higher level on one side. The stability is entirely from the lateral passive resistance of the soil into which the sheet pile is driven, like that of a free cantilever sheet pile.

2. **Anchored sheet pile walls** Anchored sheet pile walls are held above the driven depth by anchors provided at a suitable level. The anchors provided for the stability of the sheet pile, in addition to the lateral passive resistance of the soil into which the sheet piles are driven. The anchored sheet piles are also of two types.

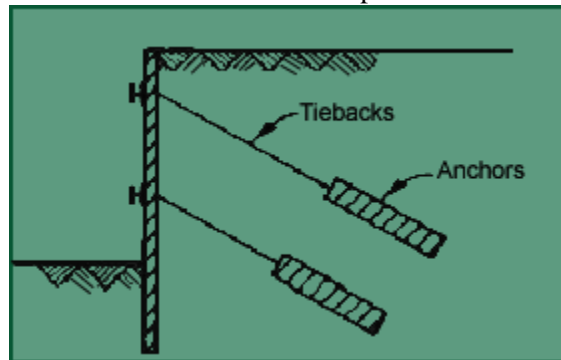

Fig. 6.7. Anchored sheet pile wall

■ **Free earth support piles.** An anchored pile is said to have free earth support when the depth of embedment is small and the pile rotates at its bottom tip. Thus there is a point of contraflexure in the pile. ■ **Fixed earth support piles.** An anchored sheet pile has fixed earth support when the depth of embedment is large. The bottom tip of the pile is fixed against rotations. There is a change in the curvature of the pile, and hence, an inflection point occurs. ■ **Diaphragm Walls** Diaphragm walls are commonly used in congested areas for retention systems and permanent foundation walls. They can be installed in close proximity to existing structures, with minimal loss of support to existing foundations. In addition, construction dewatering is not required, so there is no associated subsidence. Diaphragm walls have also been used as deep groundwater barriers through and under dams.

Diaphragm walls are constructed by the slurry trench technique which was developed in Europe, and has been used in the United States since the 1940's. The technique involves excavating a narrow trench that is kept full of an engineered fluid or slurry. The slurry exerts hydraulic pressure against the trench walls and acts as shoring to prevent collapse. Slurry trench excavations can be performed in all types of soil, even below the ground water table. Cast in place; diaphragm walls are usually excavated under bentonite slurry. The construction sequence usually begins with the excavation of discontinuous primary panels. Stop-end pipes are placed vertically in each end of the primary panels, to form joints for adjacent secondary panels. Panels are usually 8 to 20 feet long, with widths varying from 2 to 5 feet. Once the excavation of a panel is complete, a steel reinforcement cage is placed in the center of the panel. Concrete is then poured in one continuous operation, through one or several tremie pipes that extend to the bottom of the trench. The tremie pipes are extracted as the concrete raises in the trench, however the discharge of the tremie pipe always remains embedded in the fresh concrete. The slurry, which is displaced by the concrete, is saved and reused for subsequent panel excavations. When the concrete sets, the end pipes are withdrawn. Similarly, secondary panels are constructed between the primary panels, and the process continues to create a continuous wall. The finished walls may cantilever or require anchors or props for lateral support.

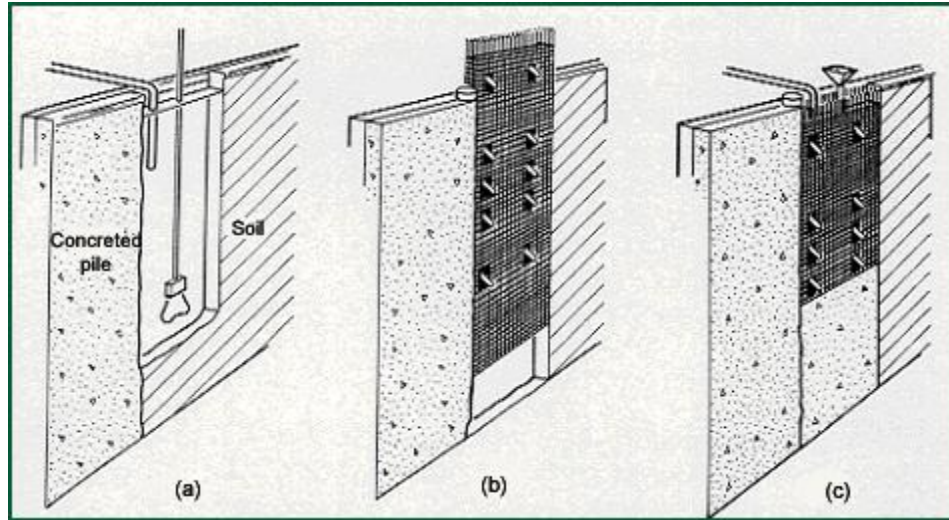
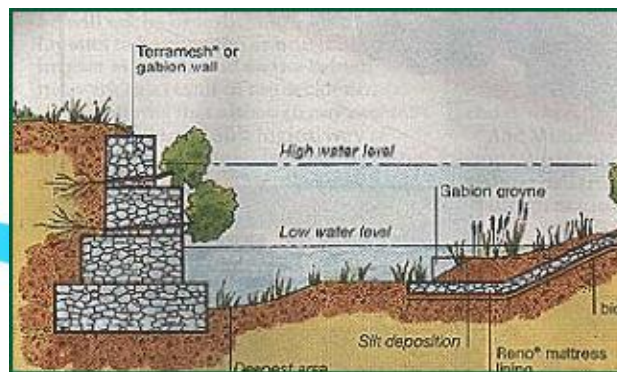

Fig. 6.8. Construction Stages of a Diaphragm Wall using Slurry Trench Technique.

4. **Special type of retaining walls**
Gabion walls

Gabion walls are constructed by stacking and tying wire cages filled with trap rock or native stone on top of one another. They can have a continuous batter (gently sloping) or be stepped back (terraced) with each successively higher course.

This is a good application where the retaining wall needs to allow high amounts of water to pass through it, as in the case of riverbank stabilization. It is important to use a filter fabric with the gabion to keep adjacent soil from flowing into or through the cages along with the water. As relatively flexible structures, they are useful in situations where movement might be anticipated. Vegetation can be re-established around the gabions and can soften the visible edges allowing them to blend into the surrounding landscape. For local roads, they are a preferred low-cost retaining structure.



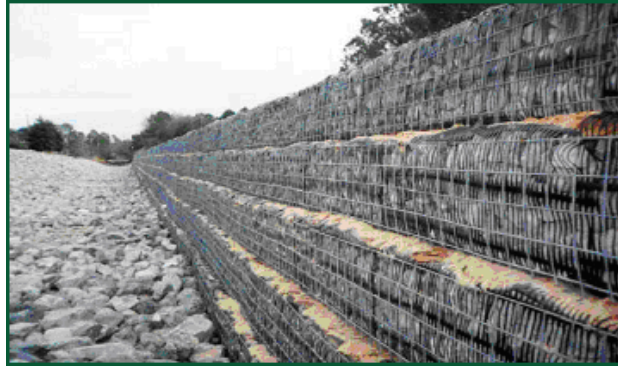

Fig. 6.9 (i) Gabion Wall

Fig.6.9 (ii) Gabion Wall

Design Requirement for Gravity walls

Gravity Retaining walls are designed to resist earth pressure by their weight. They are constructed of the mass, concrete, brick or stone masonry. Since these materials can not resist appreciable tension, the design aims at preventing tension in the wall. The wall must be safe against sliding and overturning. Also the maximum pressure exerted on the foundation soil should exceed the safe bearing capacity of the soil.

So before the actual design, the soil parameters that influence the earth pressure and the bearing capacity of the soil must be evaluated. These include the unit weight of the soil, the angle of the shearing resistance, the cohesion intercept and the angle of wall friction. Knowing these parameters, the lateral earth pressure and bearing capacity of the soil determined.

Design Requirement for Gravity walls

Gravity Retaining walls are designed to resist earth pressure by their weight. They are constructed of the mass, concrete, brick or stone masonry. Since these materials can not resist appreciable tension, the design aims at preventing tension in the wall. The wall must be safe against sliding and overturning. Also the maximum pressure exerted on the foundation soil should exceed the safe bearing capacity of the soil.

So before the actual design, the soil parameters that influence the earth pressure and the bearing capacity of the soil must be evaluated. These include the unit weight of the soil, the angle of the shearing resistance, the cohesion intercept and the angle of wall friction. Knowing these parameters, the lateral earth pressure and bearing capacity of the soil determined.

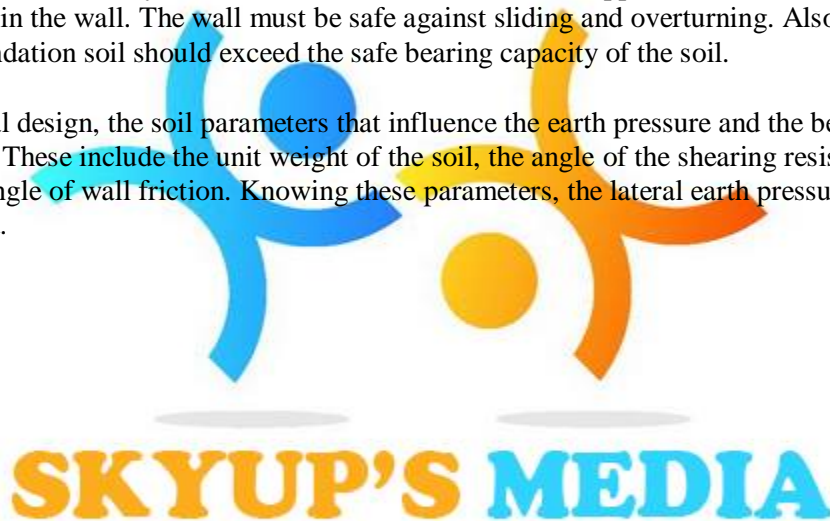

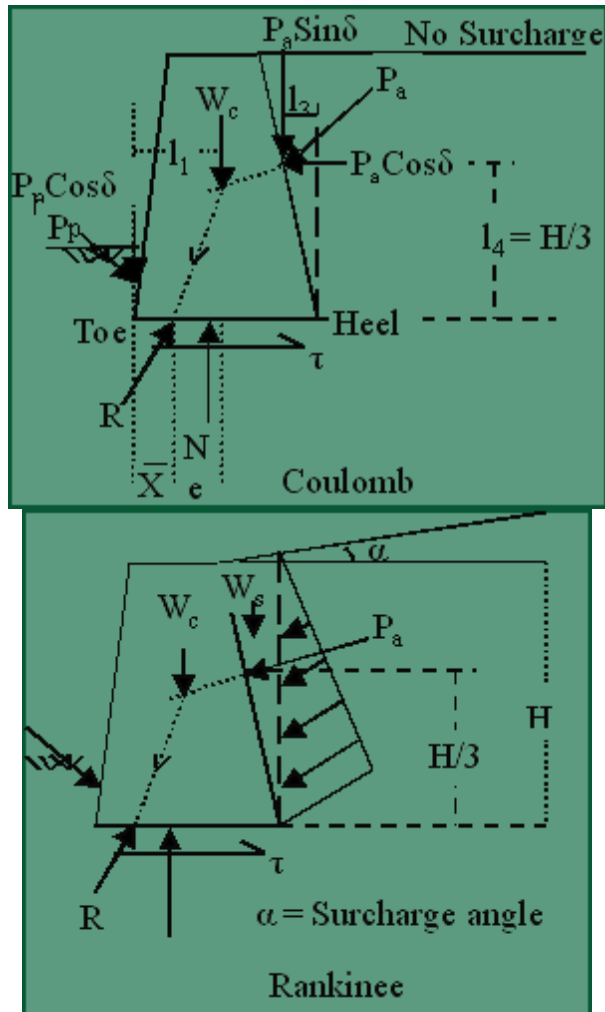

Fig-6.12a
Fig-6.12b

Fig. 6.12a shows a typical trapezoidal section of a gravity retaining wall.

The forces acting on the wall per unit length are:

- Active Earth pressure P_a .
- The weight of the wall (W_c)
- The Resultant soil reaction R on the base. (or Resultant of weight W_c & P_a). Strike the base at point D. There is equal and opposite reaction R' at the base between the wall and the foundation.
- Passive earth pressure P_p acting on the lower portion of the face of the wall, which usually small and usually neglected for design purposes. The full mobilization of passive earth pressure not occurs at the time of failure so we not consider it. If we consider it then it shows resistance against instability. So if we ignore it then we will be in safer side.

First decide which theory we want to apply for calculating the active earth pressure. Normally we calculate earth pressure using Rankine's theory or Coulomb's Earth pressure theory.

For using Rankine's theory, a vertical line AB is drawn through the heel point

(Fig 6.12-b). It is assumed that the Rankine active condition exist along the vertical line AB. While checking the stability, the weight of the soil (W_s) above the heel in the zone ABC should also be taken in to consideration, in addition to the Earth pressure (P_a) and weight of the wall (W_c).

But Coulomb's theory gives directly the lateral pressure (P_a) on the back face of the wall, the forces to be considered only P_a (Coulomb) and the Weight of the wall (W_c). In this case, the weight of soil (W_s) is need not be considered.

Once the forces acting on the wall have been determined, the Stability is checked using the procedure discussed in the proceeding section. For convenience, the section of the retaining wall is divided in to rectangles & triangles for the computation of the Weight and the determination of the line of action of the Weight.

For a safe design, the following requirement must be satisfied.

No Sliding

Horizontal forces tend to slide the wall away from the fill. This tendency is resisted by friction at the base.

$$F.S_{\text{sliding}} = \frac{\sum \text{Resisting Force } (\sum V)}{\sum \text{Sliding Force } (\sum H)} > 1.5 (\text{for Stability}) \quad (\text{General})$$

$$F.S_{\text{sliding}} = \frac{[\mu \sum W] + P_p \cdot \cos(\delta)}{P_a \cdot \cos(\delta)}$$

$$F.S_{\text{sliding}} = \frac{\mu \cdot W_c + \mu [P_a \cdot \sin(\delta)] + P_p \cdot \cos(\delta)}{P_a \cdot \cos(\delta)} \quad \therefore [\mu = \tan(\delta)] \quad (\text{Coulomb})$$

μ = Coefficient of friction between the base of the wall and soil (= $\tan \delta$).

$\sum W$ = Sum of the all vertical forces i.e. vertical component of inclined active force.

A minimum factor of safety of 1.5 against sliding is recommended.

No Overturning

The wall must be safe against overturning about toe.

$$F.S._{\text{Overturning}} = \frac{\sum M_R}{\sum M_o} \geq 1.5$$

$$F.S._{\text{Overturning}} = \frac{W_c \cdot l_1 + P_a \cdot \sin(\delta) \cdot l_2 + P_p \cdot \cos(\delta) \cdot l_3}{P_a \cdot \cos(\delta) \cdot l_4}$$

No Bearing Capacity Failure and No Tension

First calculate the line of action of the Resultant force (e) from centre of the base.

(No Tension will develop at the heel)

$$\bar{X} = \frac{[\sum M_R] - [\sum M_o] \text{ (net moment)}}{\sum V \text{ (vertical force)}}$$

$$\text{Therefore } [e = \frac{B}{2} - \bar{X}] \leq \frac{B}{6}$$

The pressure at the toe of the wall must not exceed the allowable bearing capacity of the soil. The pressure at the base is assumed to be linear. The max. Pressure at the Toe & min at the Heel is given by:

$$P_{(\text{max})} = \frac{\sum V}{B} \left(1 + \frac{6e}{B} \right) \quad P_{\text{min}} = \frac{\sum V}{B} \left(1 - \frac{6e}{B} \right)$$

$P_{(\text{max})}$ should be less than the Safe bearing capacity (q_{allow}) of the soil & $P_{(\text{max})}$ should not be Tensile in any case. Tension is not desirable. The tensile strength of the soil is very small and tensile crack would develop. The effective base area is reduced.

$$F.S._{\text{bearing capacity}} = \frac{q_{\text{allowable}}}{P_{\text{max}}} \geq 2.5$$

