



---

Area



---

Linear

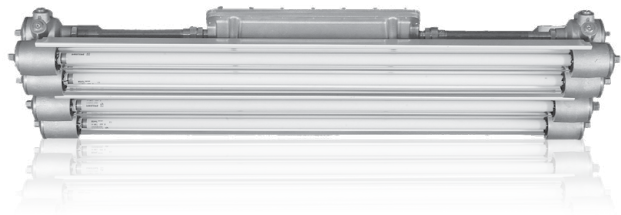

---

Emergency



---

Flood



Hazlux®  
Table of contents

<a href="#">Area lighting</a>	1
<a href="#">Linear lighting</a>	2
<a href="#">Emergency lighting</a>	3
<a href="#">Flood lighting</a>	4





# Overview

## Quality products

Thomas & Betts is committed to delivering high-quality industrial lighting fixtures designed, tested and certified for use in hazardous locations and adverse environment conditions. You can rely on Hazlux® to safely provide light where you need it — even under the harshest indoor and outdoor conditions. If safety, labor reduction, quality and reliability are your priorities, consider Hazlux lighting products.



### Features & benefits

- Nameplate displays third-party certification for all electrical and hazardous location ratings as required by NEMA, OSHA regulations and CSA. This allows for peace of mind, confirming, the right lighting fixture is installed in a certified condition.
- Cast, copper-free aluminum construction for high strength, light weight and corrosion resistance. Meets the highest life expectancy you can expect from a lighting fixture in a particular application.
- The paint used in our standard finish is baked, electro-deposited, pure epoxy powder for maximum corrosion protection. Additional paint finishes are available, offering increased protection against harsh environments.
- All exposed hardware is corrosion-resistant stainless steel, which will limit and ease maintenance required on the lighting fixture.
- Simple hinge arrangement permits “hands-free” wiring for a faster and easier installation.



# Overview

## Hazardous locations

**Hazardous location** — An area where the possibility of explosion and fire is created by the presence of flammable gases, vapors, dust, fibers or flyings.

### Class I - Gas

**Class I** - Class I locations are those in which flammable gases, flammable liquid-produced vapors or combustible liquid-produced vapors are or may be present in the air in quantities sufficient to produce explosive or ignitable mixtures.

#### Typical class I locations:

- Petroleum refineries and gasoline storage and dispensing areas
- Industrial firms that use flammable liquids in dip tanks for parts cleaning or other operations
- Petrochemical companies that manufacture chemicals from gas and oil
- Dry cleaning plants where vapors from cleaning fluids can be present
- Companies that have spraying areas where they coat products with paint or plastics
- Aircraft hangars and fuel serving areas
- Utility gas plants and operations involving storage and handling of liquified petroleum gas or natural gas

### Class II - Dust

**Class II** - Class II locations are those that are hazardous because of the presence of combustible dust.

#### Typical class II locations:

- Grain elevators, flour and feed mills
- Plants that manufacture, use or store magnesium or aluminum powders
- Plants that have chemical or metallurgical processes: producers of plastics, medicines and fireworks, etc.
- Producers of starch or candies
- Spice-grinding plants, sugar plants and cocoa plants
- Coal preparation plants and other carbon handling or processing areas

### Divisions vs. zones: area classification

Continuous hazardous	Continuous hazardous	Continuous hazardous
Zone 0	Zone 1	Zone 2
Division 1		Division 2

Note: These are simplified definitions - complete data is in the Canadian Electrical Code (C.E.C)

### Class III - Fibers

**Class III** - Class III locations are those that are hazardous because of the presence of easily ignitable fibers or where materials producing combustible flyings are handled, manufactured or used, but in which such fibers/flyings are not likely to be in suspension in the air in quantities sufficient to produce ignitable mixtures.

#### Typical class III locations:

- Textile mills, cotton gins, cotton seed mills and flax processing plants
- Any plant that shapes, pulverizes or cuts wood and creates sawdust or flyings

Note: Fibers and flyings are not likely to be suspended in the air but can collect around machinery or on lighting fixtures and a spark or hot metal can ignite them.

### Division 1 - Normally hazardous

**Division 1** - Hazardous gases or dusts are present under normal operation conditions or during frequent repair and maintenance activity.

#### Groups A, B, C, D

**Groups A, B, C and D** - The gases and vapors of class I locations are broken into four groups by the code A, B, C and D. These materials are grouped according to the ignition temperature of the substance, its explosion pressure and other flammable characteristics.

#### Groups E, F, G

**Groups E, F, G** - Class II dust locations groups E, F and G are classified according to the ignition temperature and the conductivity of the hazardous substance.

### Division 2 - Not normally hazardous

**Division 2** - Hazardous gases or dusts are not present under normal operating conditions.

## Four step method for selecting lighting fixtures for hazardous locations.

### 1. Select a fixture that meets your class, division and group requirements, for example:

- Class I, division 2, group D
- Class II, division 1, group G

### 2. Determine the t-number for your selected fixture. Be sure it is for the specific wattage, ballast housing, optical assembly and ambient temperature.

- Use the published information in this catalog or in Hazlux® product brochures

### 3. Determine the maximum allowable temperature for the hazardous materials involved.

#### Class I gas:

- Ignition temperature for the specific gas (from NFPA497M)

#### Class II dust:

- Group E - 200 °C
- Group F - 200 °C
- Group G - 165 °C
- Or ignition temperature of dust if lower
- Above from NEC® table 500-3(F)

### 4. Compare the t-number (from Step 2) to maximum allowable temperature (from Step 3).

- If t-number is cooler than the maximum allowable temperature, the selected fixture is suitable.
- If t-number is hotter than the maximum allowable temperature, the selected fixture is not suitable.

#### Divisions vs. zones: area classification

Class I, II, div. 1, 2 t-number	Max. temperature
T1	450 °C
T2	300 °C
T2A	280 °C
T2B	260 °C
T2C	230 °C
T2D	215 °C
T3	200 °C
T3A	180 °C
T3B	165 °C
T3C	160 °C
T4	135 °C
T4A	120 °C
T5	100 °C
T6	85 °C

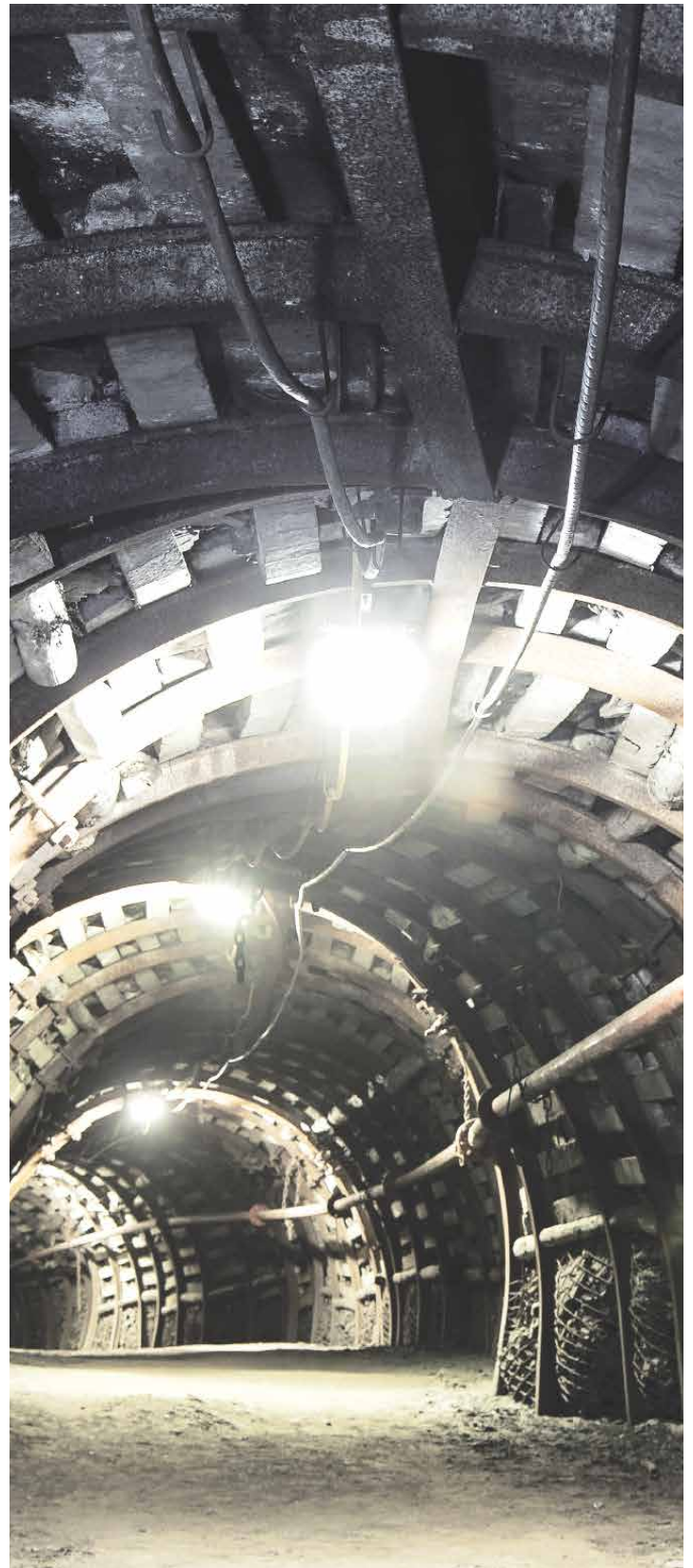



# Overview

## Hazlux® applications

From an offshore oil rig in the Atlantic Ocean to the factory floor, there's a Hazlux lighting fixture to stand up to virtually every hazardous location.

### Here are some of the places you'll find Hazlux fixtures:

- Chemical manufacturing and processing plants
- Oil refineries
- Oil drilling rigs
- Offshore platforms
- Pipeline pumping stations
- Pulp and paper plants
- Aluminum and copper smelting
- Steel mills and foundries
- Mining operations
- Grain handling facilities
- Flour, sugar and starch processing
- Food processing plants
- Paint and rubber manufacturing facilities
- Marine and coastal facilities
- Shipyards and shipbuilding plants
- Power generation plants
- Waste treatment facilities
- Paint, chemical and plastic mixing/storage areas
- Bulk truck terminals
- Solvent/cleaning areas

Hazlux lighting fixtures are built to withstand the harsh environmental conditions that exist in real settings.

1 Hose Down | 2 Vibration | 3 High Ambient | 4 Dust | 5 Corrosion | 6 Marine | 7 Ice | 8 Wind

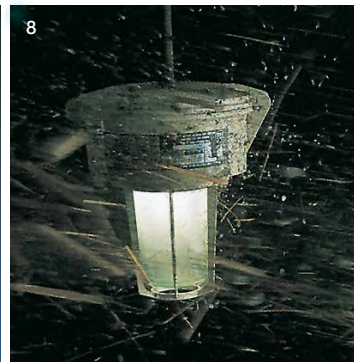
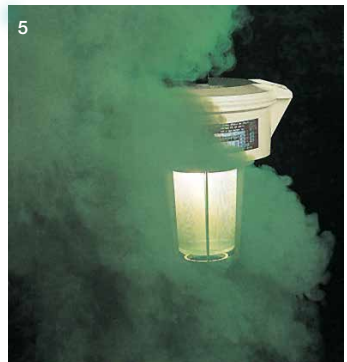
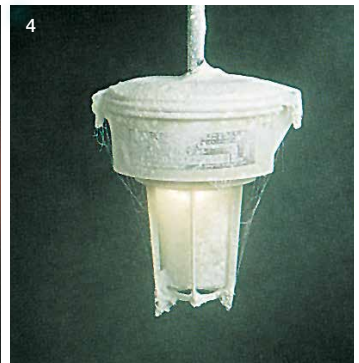
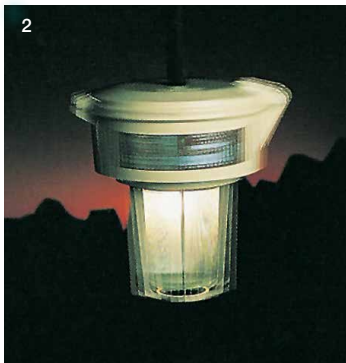



### **Hose-down and wet locations**

- Certified for wet locations—NEMA 4X, IP66 (indoor and outdoor); UL 1598A (marine) and CSA listed
- Superior gasketing system—both tank and globe gasketing systems withstand hose-down pressures
- Uninterrupted globe thread—assures positive seal
- Baked-on, dry epoxy coating—not paint but 100% dry solid
- Globes, refractors and finish designed to withstand thermal shock during hose down

### **High-ambient temperature areas**

- All standard fixtures are tested and listed for at least 40 °C ambient - even under heavy dust blanket and no air flow
- Exclusive heat sink design results in a cool operating fixture, extended driver/module life and lower maintenance costs
- Unmatched selection of high-ambient, temperature rated fixtures—contact factory for fixtures certified for 55 °C
- Steam spray and thermal shock resistant

### **Corrosion and abrasion**

- Baked-on, dry epoxy coating—not paint but 100% dry solids— Stainless steel external hardware
- Sand-blast resistant finish
- Superior silicone gasketing system on both tank and globe.
- Aluminum components contain less than 0.4% copper— maximum corrosion resistance
- Special HazCote® corrosion fighter finish available for extremely corrosive areas; consult your Thomas & Betts sales representative for details

### **Ice and arctic conditions**

- Gasketing system and finish allow for expansion and contraction through wide temperature variations
- High-strength mechanical mountings withstand extra ice loading
- Tempered glassware available for extra thermal shock safety margin

### **Vibration, seismic shock and vandalism**

- Vibration tested by UL and CSA
- Vibration-resistant hardware throughout fixture
- Screw retainers on guard ensure retention even if screws are not completely tightened
- Vibration-resistant globe thread and sealing system
- Optional refractors, high-strength tempered glass and silicon coated globes for protection from vandalism

### **Dust blanket**

- Tested and listed by UL and CSA
- Thermal performance is at 40 °C ambient; optional thermal performance to 55 °C (consult factory)
- Cone pendant mount available (45° sloped sides) for areas where dust or other residue buildup is a problem
- Exclusive heat sink design—results in a cool operating fixture, extended driver/module life and lower maintenance costs

### **Marine-duty rating**

- This feature is supplied as standard on most Hazlux® 3 fixtures
- Designed for abuse—hose down, arctic, hurricane, vibration and shock, high temperature, corrosion and other environmental conditions typical of adverse marine locations
- Exclusive combination of marine and hazardous location approvals on the same fixture line

### **Wind**

- Wind-tunnel tested at McDonnell Douglas Corporation at air flow speeds in excess of 198 mph (320 km/h)
- Guard specially designed to secure reflector during high wind loading
- All fasteners are stainless steel
- High-strength mechanical mountings withstand strong wind loads



# Area lighting

## Hazlux® 3 series

Safe, durable, and now available with LED technology for superior energy efficiency, Thomas & Betts Hazlux products are the brand specifiers rely on to safely provide light where it's needed — even under the harshest indoor and outdoor conditions. The Hazlux 3 LED series offers longer life, enhanced energy efficiency, reduced maintenance and a smaller footprint. All Hazlux LED products are designed and assembled for exceptional service and support with reduced lead times. Experienced assembly operation easily accommodates both large and small production runs with a fast turnaround.

### Maintenance-friendly

- Field-replaceable LED engine and driver

### LED fixtures with superior technology and performance

- High lumens per watt ratio
- Higher t-ratings for cooler operation and extended LED and driver life in extreme temperatures
- Available with a thermal-resistant globe and a variety of field—changeable internal and external reflectors for the ideal beam angle

### Labor-saving installation

- Designed for easy retrofit installation with existing Hazlux 3 top-hats
- Hinged design for single-person installation

### Applications

- Oil & gas
- Mining
- Food & beverage
- Chemical industries

### Advantages

- Easy tank access allows for safe, quick maintenance of Hazlux lighting fixtures
- The Hazlux LED fixtures engine and driver are designed for easy field replacement
- Cast, copper-free aluminum construction and epoxy paint provides the highest level of corrosion resistance



# Area lighting

## Hazlux® 3 LED DL-series

1

### HazVertor® adapter ring

#### Replace competitor fixtures without removing the top hat

The HazVertor adapter ring offers the freedom to replace Champ® Series by Crouse-Hinds® lighting fixtures (VMV, DMV or LMV types) with Hazlux 3 lighting fixtures without removing the Crouse-Hinds top hat from the conduit system, eliminating the need to replace conduit and wiring.

#### Save time and increase efficiency.

The HazVertor ring can be ordered as a separate item or as part of a Hazlux 3 fixture assembly. Look for the HV1 mounting style options and switch to increased efficiency, wider suitability for hazardous locations, improved light distribution and improved t-numbers.



HazVertor adapter ring

### Hazlux UNIPAK® packaging

- UNIPAK is the Hazlux customized packaging system designed to save money
- UNIPAK fixtures are easily assembled and can include globes, guards, reflectors, lamps, fuses and other options
- Outlet boxes are shipped separately; consult factory regarding outlet boxes to be assembled to UNIPAK fixtures
- Assembled UNIPAK fixtures are shipped in one carton with the fixture foam packed in place
- For ordering information, refer to the “catalog numbering system” for each individual Hazlux fixture series
- UNIPAK saves seven ways:
  - Reduces the number of cartons to receive, count, move, open and dispose
  - Reduces storage issues
  - Reduces inventory expense
  - Eliminates lost or back-ordered parts
  - Significantly reduces labor costs
  - Reduces total installed cost per fixture

#### Certifications and standards

Class I – Division 2, groups A, B, C and D

- UL® listed (UL file # E65285)
- Wet location
- Marine location on classified



Contact your Thomas & Betts sales representative to verify classification.

Note: Crouse-Hinds and Champ are registered trademarks of Cooper Technologies Company, owned by Eaton.



## Hazlux® durability meets LED technology

### High-efficacy fixtures offer excellent performance and energy savings

Thomas & Betts has taken the rugged, reliable design of Hazlux lighting fixtures and introduced the capabilities of LED technology to create a high-performance fixture with an impressive lumen output.

### Higher t-ratings and optimal thermal management extend LED and driver life expectancy

With an exclusive design that maximizes heat dissipation, Hazlux LED fixtures lower internal temperature and allow for better T-ratings which means extended LED and driver life in extreme ambient temperatures.

With the entire surface acting as a heat sink, Hazlux LED luminaires allow higher wattages for better performance.

### Versatile optics include internal reflector options for diffused light distribution

Hazlux LED fixtures are available with a thermal-resistant globe and a variety of external and field-changeable internal reflectors for the ideal beam angle from 35° to 65° for your specific applications.

Hazlux model	AC power (W)	Lumen	Lm/W
DL005	45	5,800	129
DL007	58	7,100	122
DL010	88	10,000	114
DL015	122	15,600	128
DL017	131	17,800	135
DL020	166	20,400	123

Hazlux model	Ambient temp. = 40 °C		Ambient temp. = 55 °C	
	Class I div 2	Class I div 2 & class II	Class I div 2	Class I div 2 & class II
DL005	T5	T4A	T5	T4
DL007	T5	T4A	T5	T4
DL010	T4A	T4A	T4	T4
DL015	T4	T3C	N/A	N/A
DL017	T4	T3C	N/A	N/A
DL020	T3C	T3C	N/A	N/A



Internal reflector

Internal reflector (actual application)

Note: only for models DL005, DL007 and DL010

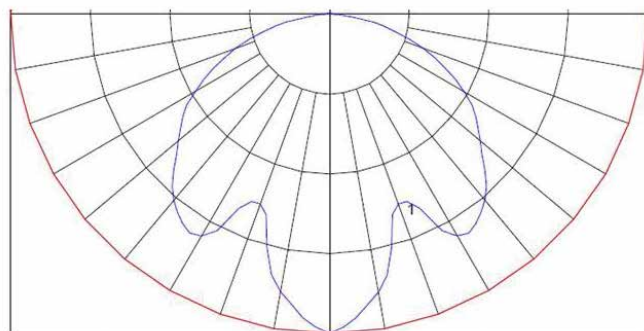

LED single board

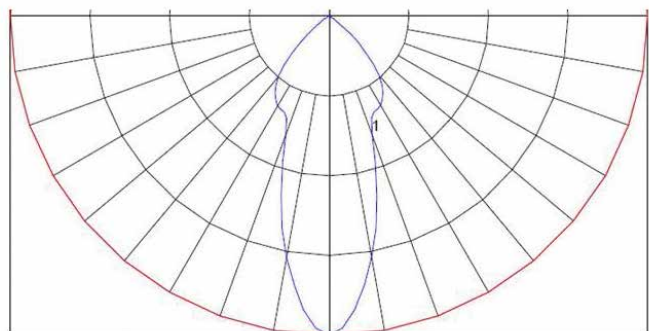

LED single board with internal reflector installed

# Area Lighting

## Hazlux® 3 series

1

### Labor-saving installation and maintenance-friendly construction.

#### Designed for easy retrofit installation

Using the same mounting style options as existing Hazlux lighting fixtures, the new LED luminaires can easily be attached as retrofit fixtures.

The HazVertor™ adapter ring makes it easy to replace Crouse-Hinds Champ® series lighting fixtures without removing the top hat from the conduit system.

#### Hinged design for hands-free wiring

Easy tank access allows Hazlux lighting fixtures to be maintained quickly and safely. The hinged lid is designed to support the weight of the tank, leaving both the installer's hands free.

#### Field-replaceable LED engine and driver

The LED driver is designed in its own compartment so it can be easily replaced in the field using a connector, with no re-wiring required. A fiberglass insulator protects the driver from the heat of the LED engine.

#### Robust construction for long life expectancy

Cast, copper-free aluminum construction offers corrosion resistance in a strong, lightweight fixture for maximum life expectancy. Baked epoxy powder finishes and stainless steel exposed hardware provide additional corrosion resistance.

#### Certifications shown on external surface

An easily identifiable nameplate displays third party certification for all electrical and hazardous location ratings as required by the NEMA, OSHA regulations and CSA to provide peace of mind, confirming that the correct lighting fixture with the required certifications is in place.

#### Now listed on the 'Design Lights Consortium' Qualified Products List

The Hazlux DL Series is now listed on the Qualified Products List (QPL) of the Design Lights Consortium (DLC) which is an institution devoted to defining and promoting leading-edge, high-quality, and high-efficiency LED products.



Note: Crouse-Hinds and Champ are registered trademarks of Cooper Technologies Company, owned by Eaton.

# Assembly guide

## Complete luminaire consists of:

- A mounting style
- Driver tank
- Globe or refractor
- Optional guard and/or reflector



## Hazlux® 3 LED DL series - assembly guide

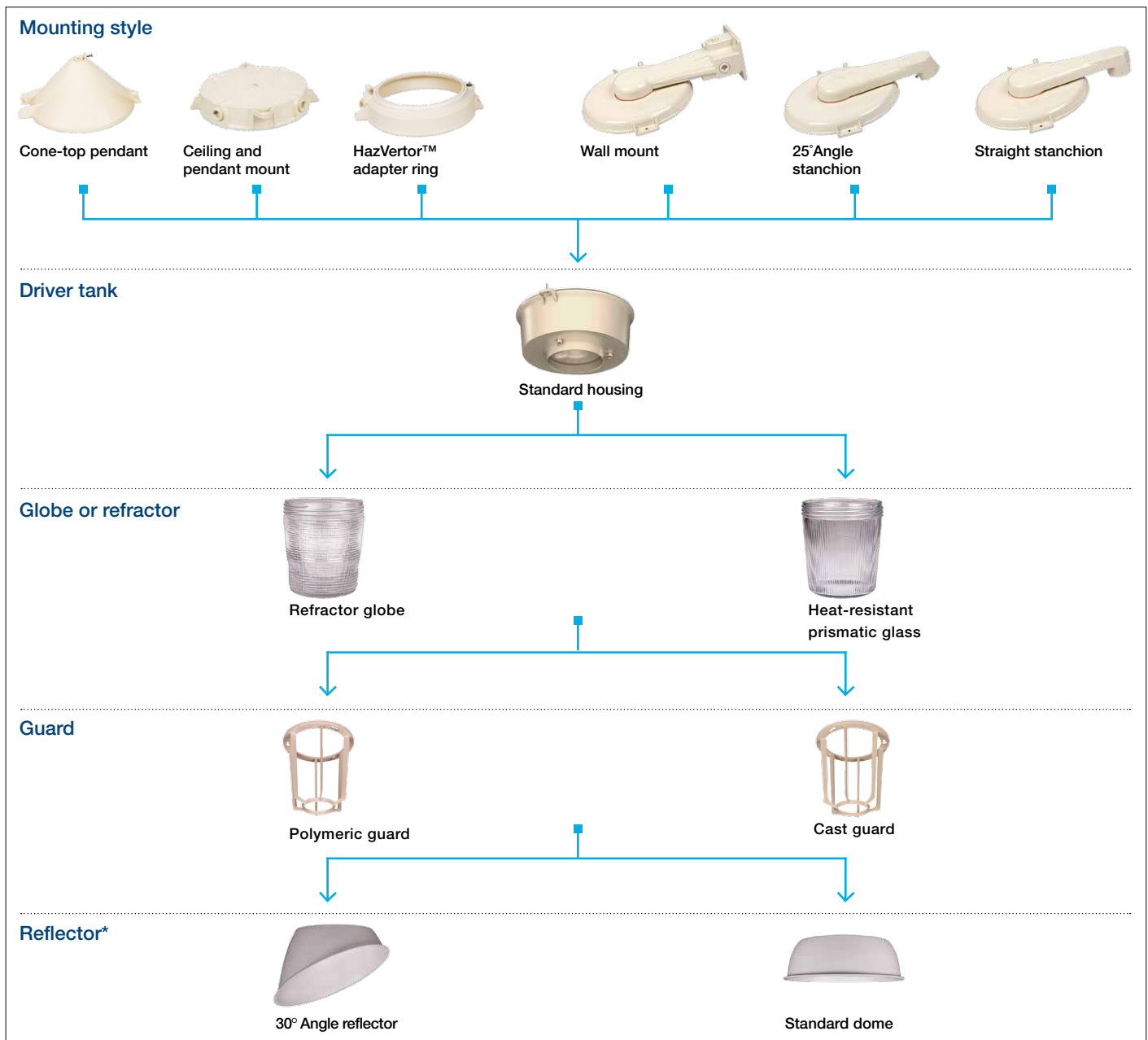

\*Reflectors are sold separately

# Area Lighting Hazlux® 3 series

1

## Catalog numbering system

### LED driver tank

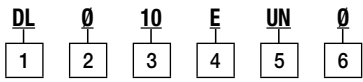

### Optics and mountings

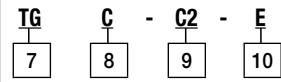

### Options

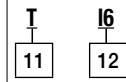

### Labeling



Hazlux DL series model	Equivalent HID luminaire
DL005	100W
DL007	175W
DL010	250W
DL015	400W

Note: For reference only

### LED driver tank

1 Fixture series	DL	Hazlux® 3 LED series
2 Fixture	Ø	Standard fixture
3 Lumen output	05	5,800 Lumens, 45W <sup>†</sup>
	07	7,100 Lumens, 58W <sup>†</sup>
	10	10,100 Lumens, 88W <sup>†</sup>
	15	15,600 Lumens, 122W <sup>†</sup>
	17	17,800 Lumens, 131W <sup>†</sup>
4 Driver circuit	20	20,400 Lumens, 166W <sup>†</sup>
	E	Electronic LED driver
	5 Voltage/frequency	UN
UN2		Universal 347/480VAC 50/60Hz (Not available for DL017 and DL020) <sup>†</sup>
6 LED driver housing style	Ø	Standard housing <sup>†</sup>
	S	Standard housing with stainless steel insert

### Optics and mountings

7 Order assembly options**	TG	Thermal & heat-resistant prismatic glass globe <sup>†</sup>
	R1	Type I glass refractor globe
	R3	Type III glass refractor globe
	R5	Type V glass refractor globe
8 Guard option	Blank	No guard <sup>†</sup>
	C	Cast aluminum guard
	L	Polymeric guard
9 Fixture	A2	¾" Cone-top pendant <sup>†</sup>
	A3	1" Cone-top pendant <sup>†</sup>
	B2	¾" Wall mount
	B3	1" Wall mount
	C2	¾" Ceiling mount <sup>†</sup>
	C3	1" Ceiling mount <sup>†</sup>
	HV1	HazVertor® ring class I div. 2 zone 2*** <sup>†</sup>
	L4	1¼" Straight stanchion
	L5	1½" Straight stanchion
	S4	1¼" 25° Angle stanchion
S5	1½" 25° Angle stanchion	
	Blank	No mounting (to replace existing fixture)
10 UNIPAK® option	E	UNIPAK with LED light source

### Certifications and standards

- Class I – Division 2, groups A, B, C and D
  - Zone 2, Group IIC, IIB and IIA
- Class II – Division 1 and 2, groups E, F and G
- Class III
  - UL 1598 A for Marine Locations
  - NEMA 4X
  - UL 844
  - CSA C22.2 No. 137.0



Contact your Thomas & Betts sales representative to verify classification. Simultaneous Class I Division 2 and Class II

### Options

11 Special options	T	HazCote® custom anti-corrosion coating <sup>†</sup>
	G	Gray color option <sup>†</sup>
12 Light distribution options	I3	Internal reflector 35° beam angle*
	I4	Internal reflector 45° beam angle*
	I6	Internal reflector 65° beam angle*

### Certifications & Labeling

13 Rating label	U	Labeled for shipment to the United States
-----------------	---	---

\* DL005, DL007 and DL010 only

\*\* For silicone coating, please add the suffix "s" before the first digit (ex. STG)

\*\*\* Not for use with HPM2 or JM5 mounts

<sup>†</sup> Option includes DLC Qualified Products Listing. Contact Thomas & Betts Technical Service to verify classification.



## Individual components (to be used with LED driver housing)

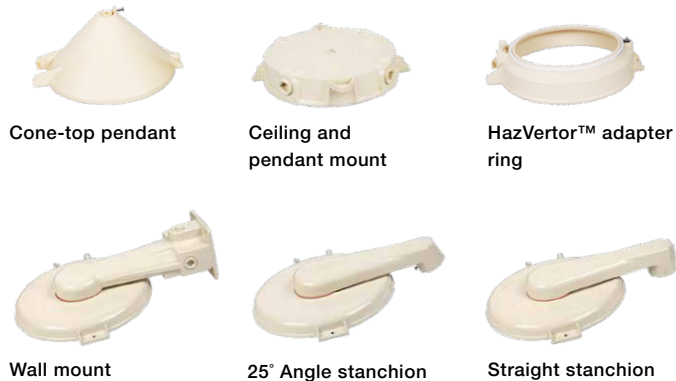

Cone-top pendant

Ceiling and pendant mount

HazVerter™ adapter ring

Wall mount

25° Angle stanchion

Straight stanchion

### Mounting options

Part No.	Description	Conduit hub size
VA2	Cone-top pendant	¾"
VA3	Cone-top pendant	1"
VC2	Ceiling mount	¾"
VC3	Ceiling mount	1"
VB2-VIB	Wall mount	¾"
VB3-VIB	Wall mount	1"
VS4-VIB	25° Angle stanchion	1¼"
VS5-VIB	25° Angle stanchion	1½"
VL4-VIB	Straight stanchion	1¼"
VL5-VIB	Straight stanchion	1½"
HV1	HazVerter™ adapter ring	N/A



Refractor globe

Heat-resistant prismatic glass globe

### Globes or refractors

Part No.	Description*
VGT15	Heat-resistant prismatic glass globe
VGL15R1	IES Type I refractor globe
VGL15R3	IES Type III refractor globe
VGL15R5	IES Type V refractor globe

\* For silicone coating, please add the suffix "s" before the first digit (ex. STG)

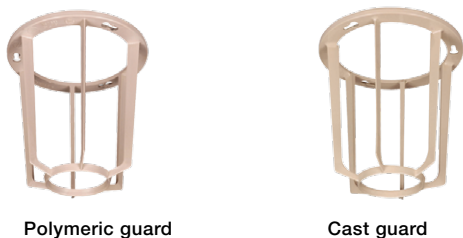

Polymeric guard

Cast guard

### Guards

Part No.	Description
VGU22P	Polymeric guard
VGU22	Cast guard

## Optional components



30° Angle reflector

Standard dome

### External reflectors

Part No.	Description
VR15P	Standard dome, fiberglass-reinforced polyester
VRA15P	Angular dome, fiberglass-reinforced polyester

## Individual components (continued)



LED engine module



Internal reflector



Internal reflector (actual application)

### LED engine modules and drivers

Hazlux cat. no.	LED engine cat. no.	Driver	
		120-277 VAC	347-480 VAC
DL005	039499-H	183.0141-H	183.0151-H
DL007	039499-H	183.0142-H	183.0152-H
DL010	039499-H	183.0143-H	183.0161-H
DL015	039501-H	183.0169-H	183.0151-H
DL017	039502-H	183.0146-H	N/A
DL020	039502-H	183.0144-H	N/A

### Internal reflectors

Cat. no.	Description
145.0056-H	I3 Internal reflector 35° beam angle
145.0057-H	I4 Internal reflector 45° beam angle
145.0058-H	I6 Internal reflector 65° beam angle

Note: only for models DL005, DL007 and DL010

### Photo sensor (Class I, div. 2, group A, B, C, D)

Cat. no.	Description
HLPC-120-FG	120VAC, 50/60Hz
HLPC-208-277-FG	208/277VAC, 50/60Hz

## Dimensions — standard housing with globe and guard

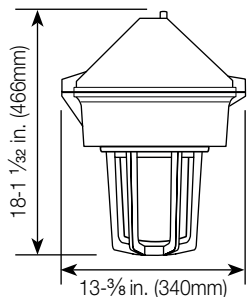

Cone-top pendant

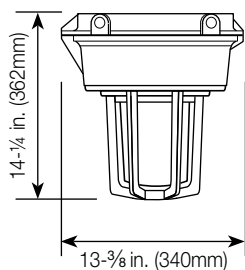

Ceiling mount

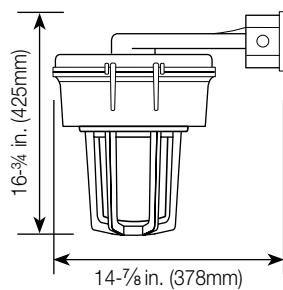

Wall mount

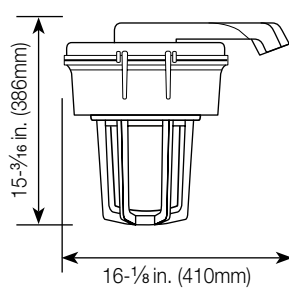

25° Angle stanchion mount

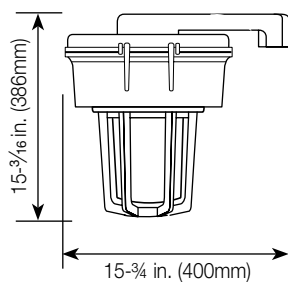

Straight stanchion

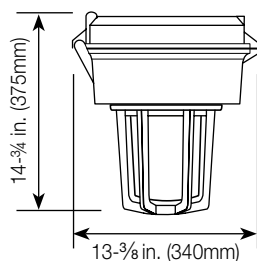

HazVektor™ ring

## Photometry — standard housing with globe and guard

### Ceiling mount

Reference data		Candlepower curve
Catalog no.	DL005EUN0TGC2EU	
Luminaire lumens	5,895	
Luminaire efficacy rating (LER)	131	
Input watt	45.07	
Spacing criterion (0-180)	1.3	
Spacing criterion (90-270)	1.3	
Spacing criterion (diagonal)	1.44	

### Ceiling mount

Reference data		Candlepower curve
Catalog no.	DL010EUN0TGC2EU	
Luminaire lumens	10,123	
Luminaire efficacy rating (LER)	115	
Input watt	88.19	
Spacing criterion (0-180)	1.24	
Spacing criterion (90-270)	1.24	
Spacing criterion (diagonal)	1.4	

### Ceiling mount

Reference data		Candlepower curve
Catalog no.	DL015EUN0TGC2EU	
Luminaire lumens	15,605	
Luminaire efficacy rating (LER)	128	
Input watt	121.8	
Spacing criterion (0-180)	1.08	
Spacing criterion (90-270)	1.08	
Spacing criterion (diagonal)	1.42	

### Ceiling mount

Reference data		Candlepower curve
Catalog no.	DL020EUN0TGC2EU	
Luminaire lumens	20,476	
Luminaire efficacy rating (LER)	123	
Input watt	166.1	
Spacing criterion (0-180)	1.46	
Spacing criterion (90-270)	1.46	
Spacing criterion (diagonal)	1.58	

# Area Lighting

## Hazlux® 3 Series

1

Photometry — standard housing with glass refractor — ceiling mount



### Ceiling mount

Reference data		Candlepower curve
Catalog no.	DL010EUN0R1C2EU	
Luminaire lumens	8,047	
Luminaire efficacy rating (LER)	92	
Total fixture watts	87	
Maximum candela	2,890	
Maximum candela (< 90° vertical)	2,890	
Maximum candela at 90° vertical	887 (11.0% luminaire lumens)	
Maximum candela from 80 to < 90° Vertical	1,463 (18.2% luminaire lumens)	luminaire

### Ceiling mount

Reference data		Candlepower curve
Catalog no.	DL010EUN0R3C2EU	
Luminaire lumens	8,649	
Luminaire efficacy rating (LER)	99	
Total fixture watts	87.27	
Maximum candela	3,731	
Maximum candela (< 90° vertical)	3,731	
Maximum candela at 90° vertical	883 (10.2% fixture lumens)	
Maximum candela from 80 to < 90° Vertical	1,308 (15.1% fixture lumens)	luminaire

### Ceiling mount

Reference data		Candlepower curve
Catalog no.	DL020EUN0R5C2EU	
Luminaire lumens	17,004	
Luminaire efficacy rating (LER)	102	
Total fixture watts	166.3	
Maximum candela	3,413	
Maximum candela (< 90° vertical)	3,413	
Maximum candela at 90° vertical	1,171.3 (6.9% fixture lumens)	
Maximum candela from 80 to < 90° Vertical	1,662.7 (9.8% fixture lumens)	luminaire



# Linear lighting







# Linear lighting

## Hazlux® 6 series

### DFP series — vapor/dust proof lighting

#### Standard features

- Front access fixture for hazardous locations
- Hinged front door frame with hinged ballast tray
- Spring loaded lamp holders – standard
- Available in 2, 3, 4, 5 and 6 lamp configurations
- Multiple hub locations can meet most wiring needs

#### Construction

- Sturdy 18 Ga. steel white powder coated housing
- 3/16" tempered glass lens
- Zinc latches

#### Electrical

- Available with low, standard or high ballast factor
- Wattage ranging from 25W in the 2 lamp low ballast factor, to 111W in the 6 lamp high ballast factor configuration (see wattage table below)
- Through feed wiring
- Voltage of 120 to 277 and 347 available

#### Options

- Adjustable surface mount brackets
- Cable mount
- Wire guard
- Acrylic lens
- 3 wire whip

#### Accessories

- Chain or cable mount kit
- Adjustable surface or vertical mounting bracket

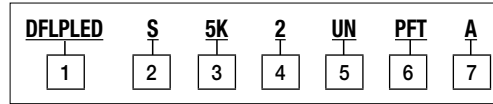

#### Ordering information

1 Fixture series	DFPLED	Hazlux vapor/dust proof lighting
2 Ballast factor	L	Low ballast factor
	S	Standard ballast factor
	H	High ballast factor
3 Color temperature	4K	4000K
	5K	5000K
4 Lamp quantity	2	2 lamp configuration, 4' length
	3	3 lamp configuration, 4' length
	4	4 lamp configuration, 4' length
	5	5 lamp configuration, 4' length
	6	6 lamp configuration, 4' length
5 Voltage	UN	Universal voltage 120-277 50/60 Hz
	34	347 volt
6 Hub	PFT	1/2" NPT hubs on top and side
7 Options	KH	Adjustable mounting brackets for surface mount
	CX	Cable mount (with 5' cable)
	PW	3 Wire whip
	WG	Wire guard
	F	Fusing
	A	Acrylic lens
	P	Polycarbonate lens

#### Certifications and standards

- Class I – Division 2, groups A, B, C and D  
 Class II – Division 2, groups E, F and G  
 Class III
- CSA 22.2 No. 137.0
  - CSA 22.2 No. 250.0
  - CSA C22.2 No. 250.13
  - UL® listed (UL 1598) wet/damp
  - UL 844
  - UL 8750
  - IP65, wet location



Contact your Thomas & Betts sales representative to verify classification.



# Linear lighting Hazlux® 6 series

2

## Dimensions - Nominal

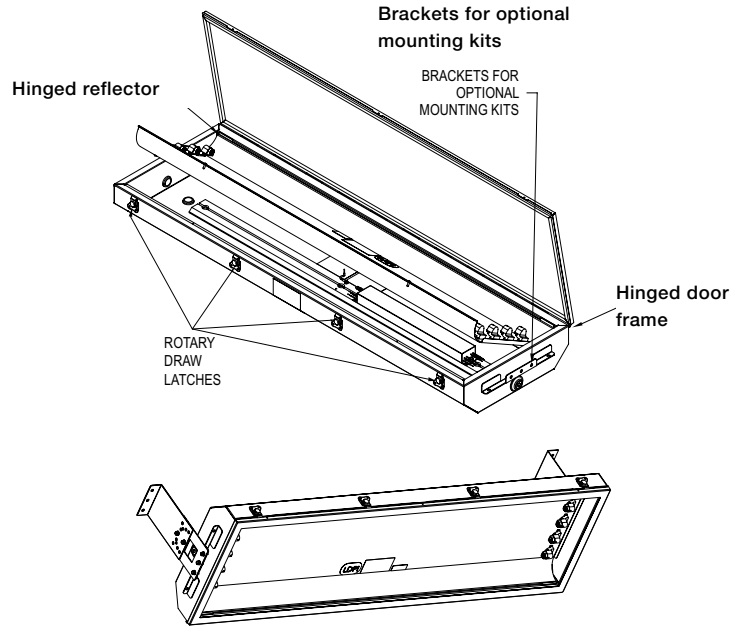
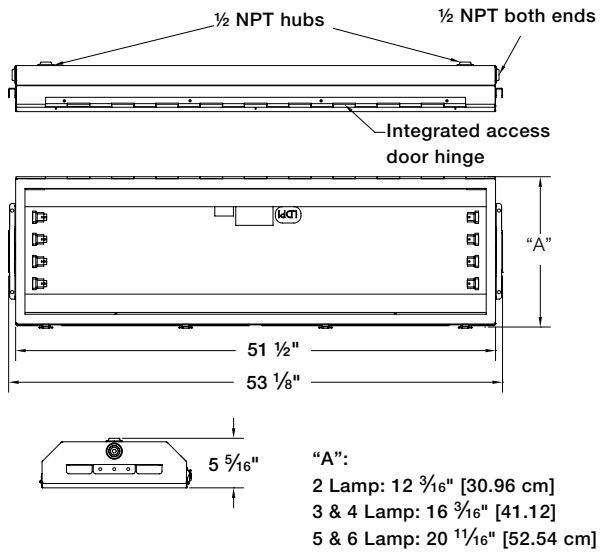

## Mounting accessory drawings (order separately)

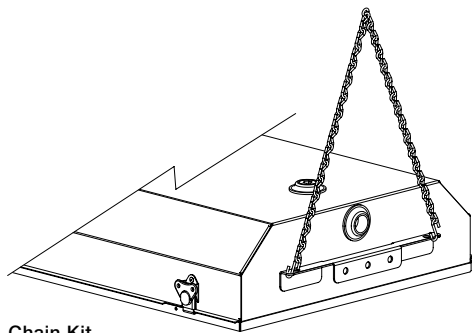

Chain Kit  
P/N: DFP-CHAIN

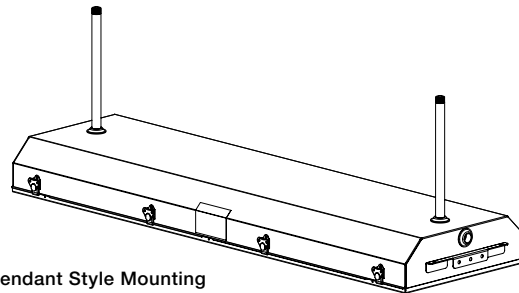

Pendant Style Mounting  
Note: Conduit supply by others  
45" between conduit

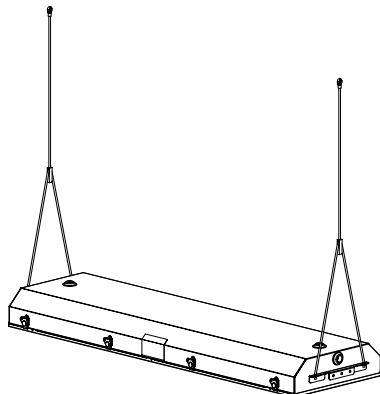

Cable Hang Kit  
P/N: DFP-CABLE (zinc coated), Qty 2 cables with toggle ends and qty 2 self locking gripples

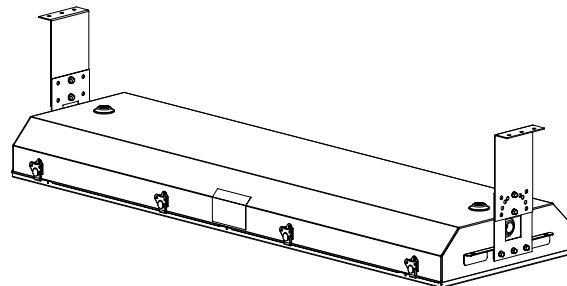

Adjustable Surface Mounting Bracket Kit  
P/N: DFP-SURFACE (galvanized), toggle ends and qty 2 self locking gripples



## Photometry - LED

### Ceiling Mount

Reference data		Candlepower Curve
Catalog no.	DFPLEDS4K434PFT	
Fixture lumens	5,737 Lumens (4 Lamps)	
Fixture efficacy rating (LER)	97	
Input watt	59.03	
Spacing criterion (0-180)	1.26	
Spacing criterion (90-270)	1.36	
Spacing criterion (diagonal)	1.44	
		luminaire

Performance				
Lamp qty.	Source (ballast factor)	Average system watts	Initial lumen output	Color temperature
2 Lamp	L: Low	25	2800, 2900	4000K, 5000K
	S: Standard	29	3200, 3300	4000K, 5000K
	H: High	37	3700, 4000	4000K, 5000K
3 Lamp	L: Low	37.5	4200, 4350	4000K, 5000K
	S: Standard	43.5	4800, 4950	4000K, 5000K
	H: High	55.5	5550, 6000	4000K, 5000K
4 Lamp	L: Low	50	5600, 5800	4000K, 5000K
	S: Standard	58	6400, 6600	4000K, 5000K
	H: High	74	7400, 800	4000K, 5000K
5 Lamp	L: Low	62.5	7000, 7250	4000K, 5000K
	S: Standard	72.5	8000, 8250	4000K, 5000K
	H: High	92.5	9250, 10000	4000K, 5000K
6 Lamp	L: Low	75	8400, 8700	4000K, 5000K
	S: Standard	87	9600, 9900	4000K, 5000K
	H: High	111	11100, 12000	4000K, 5000K

T-Ratings				
Model	Rated ambient deg. C	Class I, div 2 groups A, B, C & D	Class II, div 2 groups F & G	Class III
DFPLED	40 °C	T5 (100 °C)	T4A (120 °C)	T4A (120 °C)



# Linear lighting

## Hazlux® 7 series

### XFM series — explosion proof lighting

2

#### Standard features

- Factory sealed, lightweight cast natural aluminum
- 5 Different ½" NPT hubs entries at each end
- Center ballast placement for better balanced and low profile
- Available with 2, 3 and 4 lamp in a 4 ft length
- One piece painted aluminum reflector
- Suitable for use inside a spray booth

#### Construction

- Cast natural aluminum
- 0.189" wall Borosilicate glass tubes

#### Electrical

- Available with low, standard or high ballast factor
- Wattage ranging from 25W in the 2 lamp low ballast factor, to 74W in the 4 lamp high ballast factor configuration (see wattage table below)
- Voltage of 120 to 277 (50/60 Hz) and 347 available

#### Options

- Wall and ceiling mount kit (4 lamps)
- Wire guard
- Polycarbonate shield
- 93% reflective premium specular reflector insert

#### Accessories

- Wall, ceiling and drop mount kit

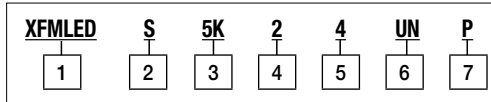

#### Ordering information

1 Fixture series	XFMLED	Explosion proof lighting
2 Ballast factor	L	Low ballast factor
	S	Standard ballast factor
	H	High ballast factor
3 Color temperature	4K	4000K
	5K	5000K
4 Lamp quantity	2	2 lamp configuration
	3	3 lamp configuration
	4	4 lamp configuration
5 Length	4	4' length
6 Voltage	UN	Universal voltage 120-277 50/60 Hz
	34	347 volt
7 Options	P	Polycarbonate shield
	WK	Stainless steel guard (not for sure in paint spray applications)
	MK	Wall/ceiling mount kit (4 lamps)



#### Certifications and standards

- Class I
- Division 1, groups C and D
  - Division 2, groups A, B, C and D
  - Zone 1, Group IIB and IIA
- Class II
- Division 1 and 2, groups E, F and G
  - Division 2, groups E, F and G
- Class III
- Class I and Class II Simultaneous Presence
- CSA C22.2 No. 137.0
  - CSA C22.2 No. 250.0
  - CSA C22.2 No. 250.13
  - UL® listed (UL 1598 wet/damp) , (UL 1598A marine outside)
  - UL 844 paint spray
  - UL 8750
  - NEMA 3, 4X, 7CD, 9EFG
  - NFPA 33
  - NEC article 516



Contact your Thomas & Betts sales representative to verify classification.  
Simultaneous presence Class I and Class II

## Dimensions - Nominal

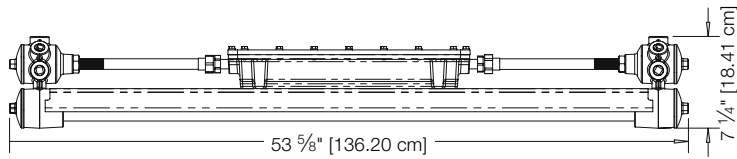
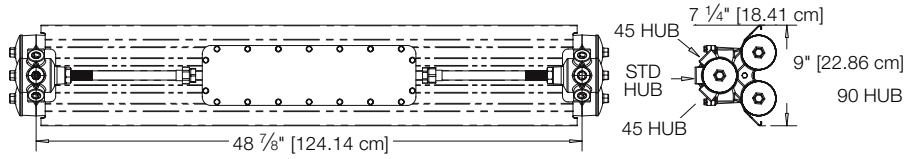

2L 4FT. Dimensions

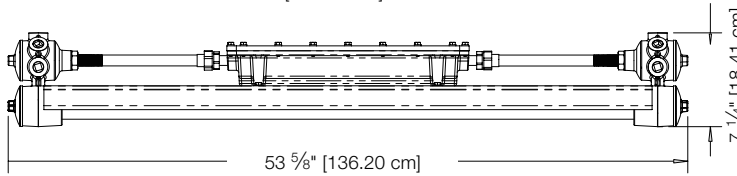
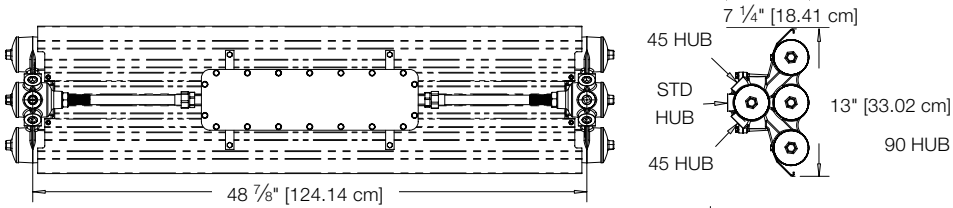

3L 4FT. Dimensions

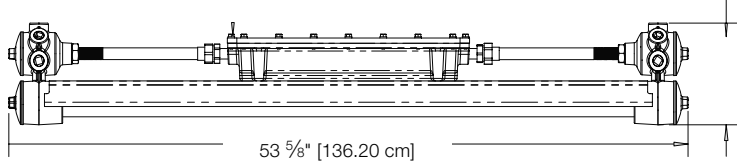
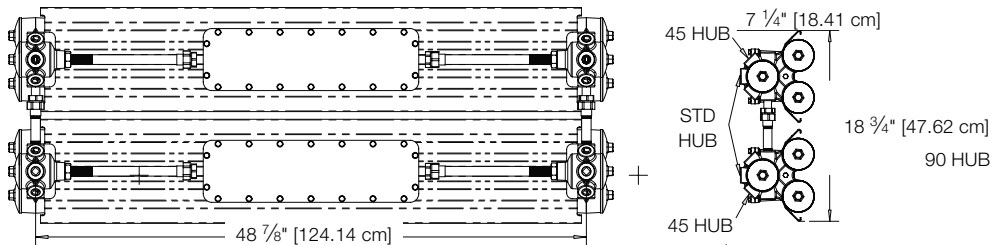

4L 4FT. Dimensions

# Linear lighting Hazlux® 7 series

## Mounting options

2

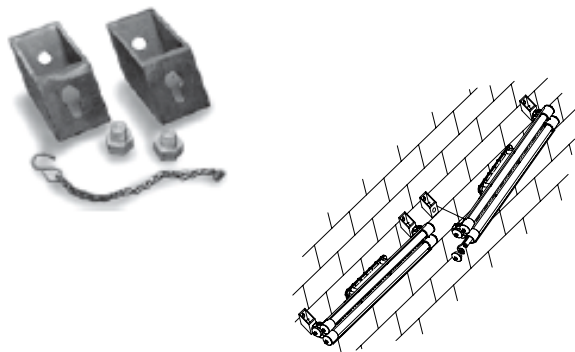

Wall/Ceiling mount kit for 2 or 3 lamps  
P/N: XFM-4401

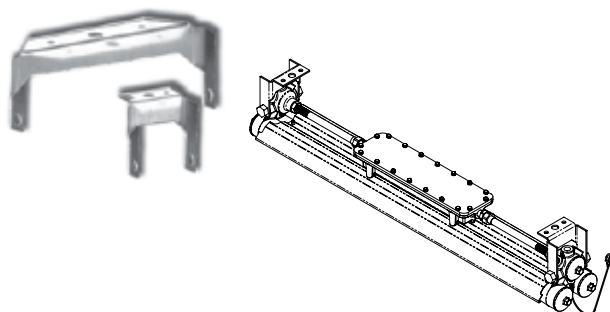

Wall/Ceiling mount kit for 4 lamps  
P/N: XFM-4400

These are factory fitted. Please contact  
T&B sales representative 1 for further details.

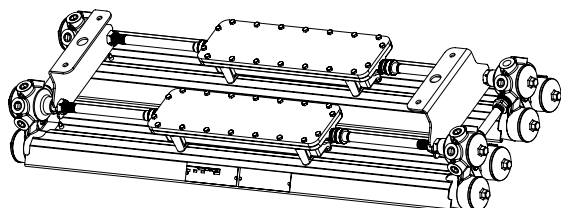

Drop mount kit for 2 or 3 lamps  
P/N: XFM-4405  
For 4 lamps  
P/N: XFM-4403

## Photometry - LED

### Ceiling mount

Reference data		Candlepower curve
Catalog no.	XFMLEDS5K24UN	
Luminaire lumens	3,024 Lumens (2 Lamps)	
Luminaire efficacy rating (LER)	105	
Input watt	28.68	
Spacing criterion (0-180)	1.26	
Spacing criterion (90-270)	1.40	
Spacing criterion (diagonal)	1.48	

### Ceiling mount

Reference data		Candlepower curve
Catalog no.	XFMLEDS5K34UN	
Luminaire lumens	4,803 Lumens (3 Lamps)	
Luminaire efficacy rating (LER)	110	
Input watt	43.72	
Spacing criterion (0-180)	1.26	
Spacing criterion (90-270)	1.40	
Spacing criterion (diagonal)	1.48	

### Performance

Lamp qty.	Source (ballast factor)	Average system watts	Initial lumen output	Color temperature
2 Lamp	L: Low	25	2800, 2900	4000K, 5000K
	S: Standard	29	3200, 3300	4000K, 5000K
	H: High	37	3700, 4000	4000K, 5000K
3 Lamp	L: Low	37.5	4200, 4350	4000K, 5000K
	S: Standard	43.5	4800, 4950	4000K, 5000K
	H: High	55.5	5550, 6000	4000K, 5000K
4 Lamp	L: Low	50	5600, 5800	4000K, 5000K
	S: Standard	58	6400, 6600	4000K, 5000K
	H: High	74	7400, 8000	4000K, 5000K

### T-Ratings

Model	Rated ambient deg. C	Class I, div 1 groups C & D	Class I, div 2 groups A, B, C & D	Class II, div 1 groups E, F & G	Class II, div 2 groups E, F & G	Class I and II simultaneous presence
XFMLED	40 °C	T6 (85 °C)	T6 (85 °C)	T4 (135 °C)	T4 (135 °C)	T4 (135 °C)









# Emergency lighting

## VE series

### Exit hazardous location Class 1 Div 2

#### Features and benefits

- Energy efficient: Consumes less than 2.5 watts in any configuration. Exit sign illuminated by long-life, energy-efficient LEDs.
- Single face heavy-duty 1/8" thick aluminum back plate. Polyvinyl chloride frame, with built-in gasket to prevent water infiltration. Will not dent, peel, rust or corrode. The sealed, heavy-duty, vandal-resistant polycarbonate faceplate features an evenly illuminated legend. The fully gasketed faceplate is fastened with stainless steel tamper-resistant screws. Self contained; batteries and circuitry are located inside the exit housing.
- Available with sealed, maintenance-free nickel-cadmium batteries that provide 90 minutes of emergency operation. Batteries recharge per UL 924 requirements.
- AC and self-powered models have universal, 2-wire input 120V to 277VAC, 60Hz.
- Tamper-resistant, hermetically sealed magnetic test switch for self-powered models.
- Diagnostic/self-test (non-audible) circuitry is standard on all self-powered models. This circuitry is programmed to ensure the exit sign's readiness and reliability by continuously monitoring every critical function of the unit. If a problem occurs, a single "service required" indicator illuminates immediately. A detailed diagnostic display that will further indicate the nature of the fault is located on the inside of the exit sign, out of sight from the general public. The self-test will test the unit for a minimum of 30 seconds every 30 days, 30 minutes every 60 days and 90 minutes annually.
- Can be wall, end or ceiling mounted. Comes standard with an industrial-grade, die-cast aluminum electrical box 1/2" electrical conduit entry on both sides and at the top. Each unit comes standard with one tamper-proof driver bit.
- Legend and chevron comply with UL requirements. Evaluated to UL 844 standard for Class I Division 2, Groups A, B, C and D. Temperature code: T6 (maximum 185 °F/85 °C). Evaluated to UL 924 and UL 1598 standards. Suitable for cold-weather: -4 °F/-20 °C (self-powered model, "CW" option) and -40 °F/-40 °C (AC only).



#### Dimensions

Dimensions are approximate and subject to change.

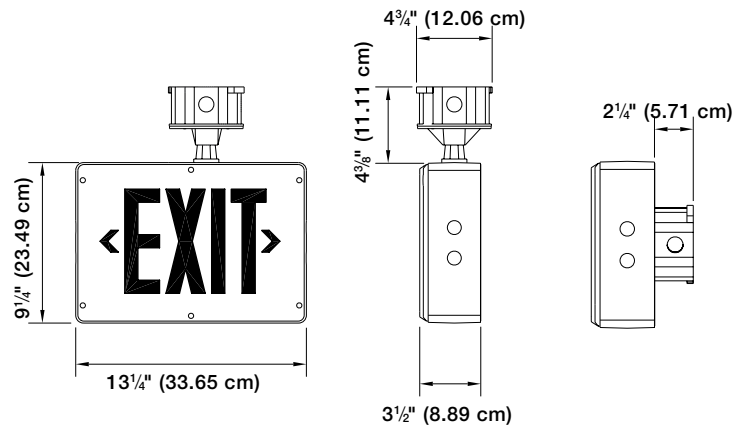

#### Power consumption

Model	AC specs	DC specs		
AC-only red	120 to 277VAC	Less than 2W	—	—
AC-only green	120 to 277VAC	Less than 1.5W	—	—
Self-powered red	120 to 277VAC	Less than 2W	Ni-Cd battery	Min. 90 minutes
Self-powered green	120 to 277VAC	Less than 2.5W	Ni-Cd battery	Min. 90 minutes

\*Note: Cold-weather option does not consume additional power.

#### Accessories (order as a separate item)

Description	Part number
Tamper-proof bit (extra)	690.0454-H

#### Applications

- Manufacturing plants
- Chemical plants
- Paint shops
- Gas stations
- Moisture, dirt or dust concerns
- Oil refineries
- Wet or corrosive conditions

#### Ordering information

Series	Face(s)	Voltage	Color of Body/face	Legend	Diagnostic	Options
VE= AC/DC VEN= Self-powered (Ni-Cd)	1= single (Ceiling/wall mount) 2= double (Ceiling mount only)	03= 120 to 277V 60 HZ	GG= Gray/Gray	R= red G= green	Blank = Diagnostic (non-audible) D=Diagnostic audible (Self-Powered Only)	CW= Cold weather (-4 °F/ -20 °C for self-powered) (-40 °C for AC/DC)

Example: VE103GGRDCW

# Emergency lighting VC combo series

## Exit hazardous location Class 1 Div 2

### Features and benefits

- Exit sign module is illuminated by long-life, energy-efficient LEDs. Fully field adjustable lamp head assembly comes standard with a selection of two (2) MR16 halogen lamps for optimum illumination over the path of egress. Lamps are shielded by a cast aluminum housing and a polycarbonate cover.
- Rugged PVC body will not dent, peel or corrode. The sealed faceplate has a heavy-duty, vandal-resistant polycarbonate cover and is fastened with stainless steel tamper-resistant screws. The polyvinyl chloride frame has a built-in gasket to prevent water infiltration. The heavy-duty 1/8" thick aluminum back plate has keyholes for secure wall mount installation.
- Available with sealed, maintenance-free nickel-cadmium, or nickel-metal hydride batteries.
- Fully automatic pulse charger offers 120/277VAC, 60Hz, current limiting temperature compensation, short circuit proof, low voltage battery disconnect, brownout protection and standard solid state transfer feature. The test switch is magnetically operated.
- Ambient temperature: 10 to 40 °C (50 to 104 °F.)
- Advanced diagnostic (non-audible) circuitry is standard on all self-powered models. This circuitry is programmed to ensure the combination unit's readiness and reliability by continuously monitoring every critical function of the unit. If a problem occurs, a single "Service Required" indicator illuminates immediately. A detailed diagnostic display that will further indicate the nature of the fault is located on the inside of the exit sign, out of sight from the general public. The self test will test the unit for a minimum of 30 seconds every 30 days, 30 minutes every 60 days and 90 minutes annually.
- Designed for wall-mount installation only with a 1/2" electrical conduit entry on both sides and at the top.
- Evaluated to UL 924 standard and to UL 844 standard for hazardous locations: Class I Division 2, Groups A, B, C and D. A range of lamp ratings are available for different temperature codes.

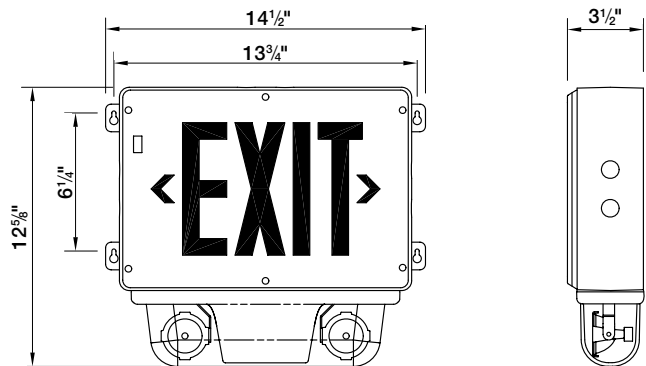

### Power consumption chart

Model	AC input	Maximum		Stand-by		Unit Rating*			
		Current	Power	Current	Power	1 1/2 hours	2 hours	3 hours	4 hours
VC	120/277VAC	0.15/0.07A	16W	0.09/0.03A	8W	20	15	—	—
VC12N	120/277VAC	0.30/0.08A	29W	0.13/0.05A	10W	24	18	12	—
VC12H	120/277VAC	0.30/0.08A	29W	0.13/0.05A	10W	40	30	20	12

\*Watts to 87 1/2% of rated battery voltage.

### Accessories (order as a separate item)

Description	Part number
Additional special bit for tamper-proof screws	690.0454-H

### Applications

- Manufacturing plants
- Chemical plants
- Paint shops
- Gas stations
- Moisture, dirt or dust concerns
- Oil refineries
- Wet or corrosive conditions

### Ordering information

Series/capacity	Lamp/wattage	Voltage	Housing/face color	Legend color	Diagnostics options
VC= 6V-20W, Ni-Cd VC12N= 12V-24W, Ni-Cd VC12H= 12V-40W, NiMH	L1= 6V-4W, 2x MR16 LED (199 Lm) L7= 12V-4W, 2x MR16 LED (220 Lm) L9= 12V-5W, 2x MR16 LED (340 Lm) M12= 12V-12W, 2x MR16 (135 Lm) M10= 6V-10W, 2x MR16 (77 Lm) MH20= 12V-20W, 2x MR16-IR (417 Lm)	03= 120/277V 60HZ	GG= gray/gray (default gray)	R= red legend G= green legend	Blank = Diagnostic (non-audible) DA= Advanced diagnostics (audible)

Example: VCL103GGRDA

# Emergency lighting

## VE series

### Hazardous location battery unit Class 1 Div 2

#### Features and benefits

- Evaluated to the UL 844 standard for Class I Division 2, Groups A, B, C and D
- A range of lamp ratings are available for different temperature codes
- Evaluated to UL 924 standard
- Certified for use in damp locations
- Ambient temperature: 10... 40 °C (50... 104 °F)
- Advanced diagnostics non-audible standard
- Lead-calcium batteries are sealed, maintenance-free, with up to 72W emergency power
- Choice of MR16 LED or halogen lamps, shielded by a clear polycarbonate cover
- Two MR16 LED lamps illuminate up to a 60 ft path of egress
- Remote load capacity: Illuminate up to a 420 ft path of egress with LED remote heads
- Heavy-duty 1/8" thick aluminum back plate with keyholes for secure wall-mount installation
- Built-in microcontroller-based battery charger and self-test/self-diagnostic circuitry
- 3/4" electrical conduit entry on both sides and at the top
- Certified for use in damp locations



#### Dimensions

Dimensions are approximate and subject to change.

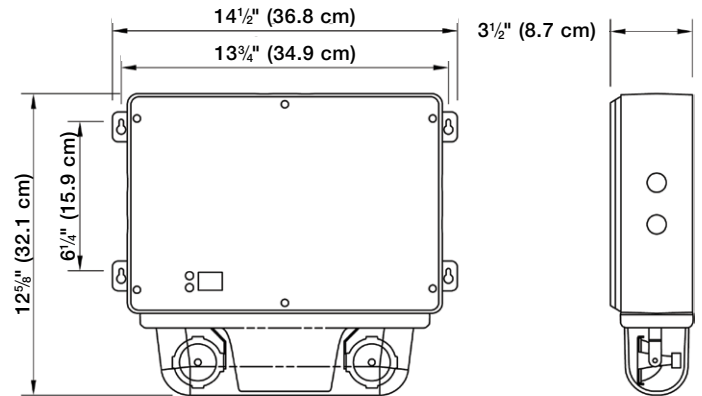

#### Temperature codes (ambient temperature 40 °C)

Lamp rating	Temperature code	Max. temperature	Replacement part number
6V-4W	T4A	248 °F/120 °C	580.0097-H
6V-10W	T3C	320 °F/160 °C	580.0079-H
12V-4W	T4A	248 °F/120 °C	580.0080-H
12V-5W	T4A	248 °F/120 °C	580.0104-H
12V-12W	T3A	356 °F/180 °C	580.0080-H
12V-20W-H	T2D	419 °F/215 °C	580.0068-H

Note: Use qualified replacement lamps to avoid risk of over-heating.



#### Power consumption

Model	AC specs		Wattage capacity				
			1 1/2 hours	2 hours	3 hours	4 hours	8 hours
VB0618	120/277VAC	0.17 / 0.09 amp	18	12	9	-	-
VB1236		0.30 / 0.15 amp	36	27	18	14	-
VB1260		0.30 / 0.15 amp	60	45	30	24	12
VB1272		0.30 / 0.15 amp	72	54	36	28	14

#### Ordering information

Series	Lamps	Voltage	Color	Diagnostic option	Options
VB0618= 6V-18W, Lead-Calcium	L1= 6V-4W, 2x MR16 LED (199 Lm)	03= 120/277V 60 HZ	-G= gray housing	Blank = Diagnostic (non-audible) DA= Diagnostics Audible	T1= Time delay 5 minutes T2= Time delay 10 minutes T3= Time delay 15 minutes T4= Time delay 20 minutes T5= Time delay 30 minutes
VB1236= 12V-36W, Lead-Calcium	L7= 12V-4W, 2x MR16 LED (220 Lm)				
VB1260= 12V-60W, Lead-Calcium	L9= 12V-5W, 2x MR16 LED (340 Lm)				
VB1272= 12V-72W, Lead-Calcium	M10= 6V-10W, 2x MR16 (77 Lm)				
	M12= 12V-12W, 2x MR16 (135 Lm)				
	MH20= 12V-20W, 2x MR16-IR (417 Lm)				
	0= No heads				

Example: VB0618L103GDAT1

# Emergency lighting VC combo series

## Remote fixture for hazardous locations Class 1 Div 2

### Features and benefits

- Available with single or double lamp heads with high-efficiency MR16 halogen lamps of 10W, 12W or 20W (see How to Order information) and MR16 high-output LEDs (4W, 5W and 6W)
- Die-cast aluminum back plate with gasket. Clear polycarbonate cover, UV and impact resistant
- Input voltage: 6V, 12V
- Easy installation on a 4" octagonal box (included). Comes standard with tamper-proof screws and bit
- Evaluated to UL 844 standard for Class I Division 2, Groups A, B, C and D. Temperature codes: T3B (10W and 12W MR16 lamps) and T2C (20W MR16 lamps) and T4A and T5 MR16 LED.
- Extreme operational temperature range: -40 °F to +104 °F (-40 °C to +40 °C)
- Indoor use
- Fully adjustable tool-less aiming swivel
- Tool-less easy lamp replacement
- Surface mount
- Conduit entry 1/2" NPT



### Dimensions

Dimensions are approximate and subject to change.

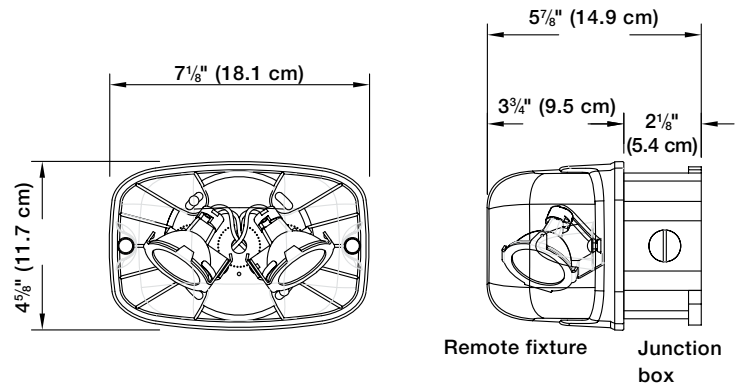

### Lamp selection chart and temperature code

Lamp suffix	Voltage	Wattage	Lumens	Replacement number	Temperature code	Max. temperature
M10	6	10	77	580.0079-H	T3B	165 °C
M12	12	12	135	580.0080-H	T3B	165 °C
M20H	12	20-H	417	580.0068-H	T2C	230 °C
L1	6	4	199	580.0097-H	T4A	120 °C
L7	12	4	220	580.0093-H	T5	100 °C
L9	12	5	340	580.0104-H	T4A	120 °C
L10	12	6	540	580.0106-H	T4	135 °C

### Ordering information

Series	Lamp type/wattage	Voltage	Color
VR= Single, C1D2	L1= 6V-4W, MR16 LED (199 Lm)	Blank= LED Lamp*	G=gray
VRD= Double, C1D2	L7= 12V-4W, MR16 LED (220 Lm)	6= 6V	
	L9= 12V-5W, MR16 LED (340 Lm)	12= 12V	
	L10= 12V-6W, MR16 LED (540 Lm)		
	M10= 6V-10W, MR16 (77 Lm)		
	M12= 12V-12W, MR16 (135 Lm)		
	MH20= 12V-20W, MR16-IR (417 Lm)		

Example: VRL16-G

\*Not required for LED lamp

# Emergency lighting

## MR16 LED

### MR16 LED illumination

With the remarkable technology development in the last decade, the lightemitting diode (LED) is becoming the preferred solution in lighting applications. The emergency lighting industry is no exception: today virtually every new product introduced to market includes “white light” LEDs for emergency illumination. Extremely efficient and long-lasting, LED lamps become the natural alternative to incandescent lamps due to three main advantages:

- **Lamp efficacy:** 50–100 lumens per watt compared to 15–30 lumens per watt of the best halogen lamp. Allowing for smaller batteries and units and/or remote capacity
- **Operational life:** 30,000+ hours, equivalent to a lifetime warranty in emergency lighting.
- **Lower lamp temperature:** 80–120 °C (176–248 °F) is a huge benefit for lighting in hazardous locations.



### 200-220-Lumen 4W MR16 LED

Leading the technology trend, Hazlux® offers a complete series of 4W MR16 LED lamps available for all the standard battery voltages: 6V, 12V, 24V and 120V. With up to 30,000 hours of operational life and a luminous flux of typically 200 to 220 lumens, they are available with most emergency heads designed to hold an MR16 lamp and meet the majority of illumination specifications. For example: one pair of LED emergency heads installed at a height of 7.5ft illuminates a 6ft by 55ft path of egress.



### 340-Lumen 5W MR16 LED

Keeping pace with technology, in 2012 we introduced a 12V-5W MR16 LED lamp. With a typical luminous flux of 340 lumens, this lamp has the same lighting performance as a 20W high-output halogen MR16. A twin emergency head installed at a height of 7.5ft illuminates 70ft path of egress.



### 540-590 Lumen 6W MR16 LED

A 6W MR16 LED lamp delivers up to 590 lumens for an average spacing in emergency lighting of 106 feet with an efficacy of 98.3 Lm/W - it is over 6 times the efficacy of a MR16 35W halogen with similar light output. This lamp can deliver the highest linear foot of illumination per watt on a path of egress! Spacing in ft/watt for the LED version is 8.83' compared to 1.37' for a MR16 35W.

### MR16 LED lamp benefits

- Reduces total cost of ownership by using fewer fixtures due to superior illumination, thus reducing installation costs and future maintenance of the entire system.
- UL-recognized components.
- Available for standard battery voltages 6V, 12V and 24V as well as 120V operation.
- Energy-efficient LED MR16 lamp provides equivalent lighting performance to a much higher watt halogen MR16 lamp.
- Reduces required battery capacity by 75%, for battery units and remote heads.
- Small profile, compact white lighting is ideal for architectural applications.
- Typical 30,000 hours of operational life.
- Vibration-resistant LED stands up to industrial environments.
- Ideal for indoor and outdoor use.

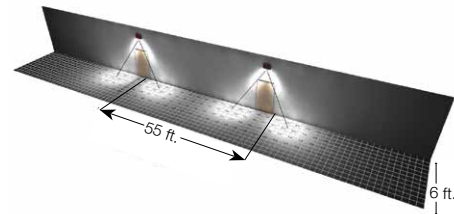

55-ft. Path of egress 2 X 4W MR16 LED  
Based on an average of 1 foot candle

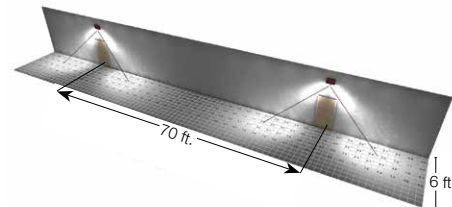

70-ft. Path of egress 2 X 5W MR16 LED  
Based on an average of 1 foot candle

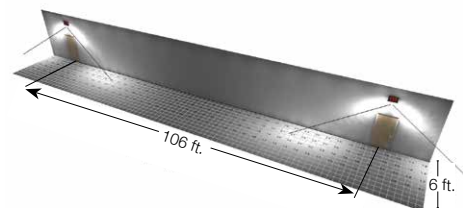

106-ft. Path of egress 2 X 6W MR16 LED  
Based on an average of 1 foot candle



**Case Study: Fewer MR16 LED units required**

**Emergency lighting units with MR16 LED lamps provide the same illumination at floor level using significantly less units:**

- Reduced installation costs, less product needed and labor.
- Reduced energy costs, keeping batteries charged at full capacity to be ready to respond to an emergency situation at any time.
- Reduced maintenance and testing cost, less units to maintain and test in the emergency lighting system.
- Reduced lamp replacement cost. LED lamps have a 30,000+ hour lamp life compared to only a few hundred hours, which is typical for incandescent lamps.
- Reduced environmental impact, less product materials, less batteries, less transportation, less packaging, less labor, less waste.

**Compare**

Where the building code requires an average of 1 foot-candle and a minimum of 0.1 foot-candle at floor level along the path of egress on a 150' x 9' x 9' corridor with an egress door at one end, a 150' x 6' path of egress, and a 7.5' unit mounting height:

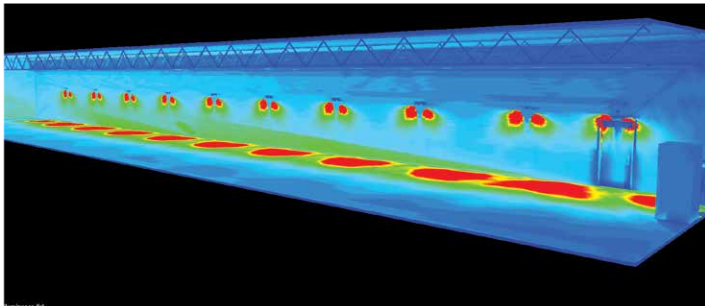

9 twin lamp heads required.

**Standard wedge-base 9W incandescent lamp**

Standard Emergency Lighting Units with 9W wedge-base incandescent lamps requires a total of 10 double-head units or remotes

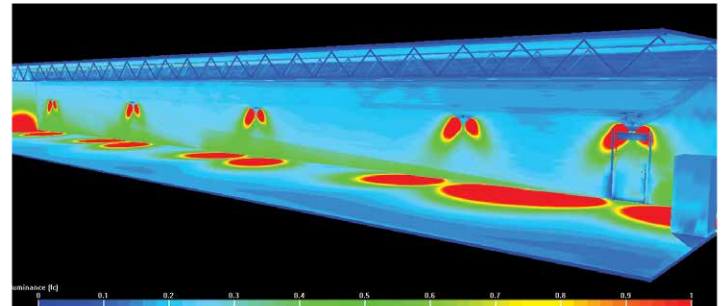

Only 5 dual lamp heads required.

**4W MR16 LED lamps**

Same standard emergency lighting units with 4W MR16 LED lamps requires a total of 5 double-head units or remotes

MR16 LED lamps				
Lamp suffix	Voltage	Wattage	Lumens	Replacement #
LA	6	4	130	580.0097-E
LG	12	4	170	580.0093-E

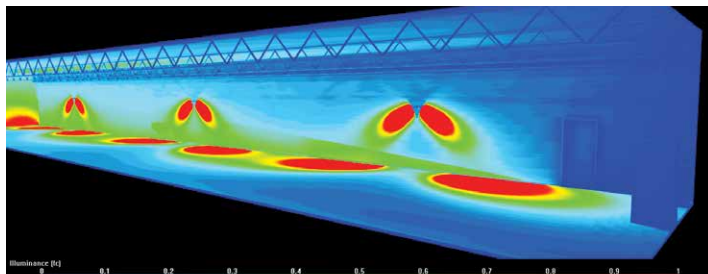

Only 3 dual lamp heads required.

**5W MR16 LED lamps**

Same standard emergency lighting units with 5W MR16 LED lamps requires a total of 3 double-head units or remotes

5W MR16 LED lamps				
Lamp suffix	Voltage	Wattage	Lumens	Replacement #
LJ	12	5	340	580.0104-E

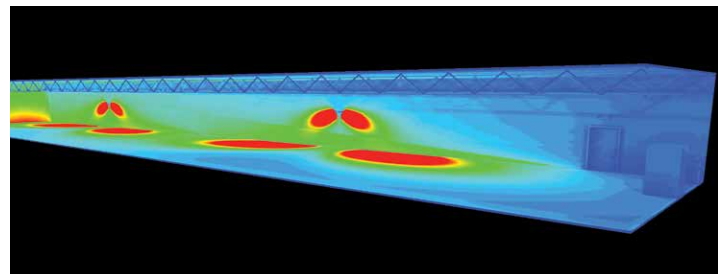

Only 2 dual lamp heads required.

**New! 6W MR16 LED lamps**

Same standard emergency lighting units with 6W MR16 LED lamps requires a total of 2 double-head units or remotes

6W MR16 LED LAMPS				
Lamp suffix	Voltage	Wattage	Lumens	Replacement #
LK	12	6	540	580.0106-E

# Emergency lighting

## National electrical code

### ARTICLE 700 – EMERGENCY SYSTEMS

#### I. General

##### 700.1. Scope.

The provisions of this article apply to the electrical safety of the installation, operation, and maintenance of emergency systems consisting of circuits and equipment intended to supply, distribute, and control electricity for illumination or power, or both, to required facilities when the normal electrical supply or system is interrupted.

(FPN No. 1): For further information regarding wiring and installation of emergency systems in health care facilities, see Article 517.

(FPN No. 2): For further information regarding performance and maintenance of emergency systems in health care facilities, see Standard for Health Care Facilities, NFPA 99-2012.

(FPN No. 3): Emergency systems are generally installed in places of assembly where artificial illumination is required for safe exiting and for panic control in buildings subject to occupancy by large numbers of persons, such as hotels, theaters, sports arenas, health care facilities, and similar institutions. Emergency systems may also provide power for such functions as ventilation where essential to maintain life, fire detection and alarm systems, elevators, fire pumps, public safety communications systems, industrial processes where current interruption would produce serious life safety or health hazards, and similar functions.

(FPN No. 4): For specification of locations where emergency lighting is considered essential to life safety, see Life Safety Code, NFPA 101-2012.

(FPN No. 5): For further information regarding performance of emergency and standby power systems, see Standard for Emergency and Standby Power Systems, NFPA 110-1999.

##### 700.2. Definitions

**Emergency Systems.** Those systems legally required and classed as emergency by municipal, state, federal or other codes, or by any governmental agency having jurisdiction. These systems are intended to automatically supply illumination, power or both, to designated areas and equipment in the event of failure of the normal supply or in the event of accident to elements of a system intended to supply, distribute, and control power and illumination essential for safety to human life.

Informational Note: Emergency systems are generally installed in places of assembly where artificial illumination is required for safe exiting and for panic control in buildings subject to occupancy by large numbers of persons, such as hotels, theatres, sports, arenas, health care facilities, and similar institutions. Emergency systems may also provide power for such functions as ventilation where essential to maintain life, fire detection and alarm systems, elevators, fire pumps, public safety communications systems, industrial processes where current interruption would produce serious life safety or health hazards, and similar functions.

**Relay automatic Load Control.** A device used to set normally dimmed or normally-off switched emergency lighting equipment to full power illumination levels in the event of a loss of the normal supply by bypassing the dimming/switching controls, and to return the emergency lighting equipment to normal status when the device senses the normal supply has been restored.

Informational Note: See ANSI/UL 924, Emergency Lighting and Power Equipment, for the requirements covering automatic load control relays.

##### 700.3. Tests and Maintenance.

(A) **Conduct or Witness Test.** The authority having jurisdiction shall conduct or witness a test of the complete system upon installation and periodically afterward.

(B) **Tested Periodically.** Systems shall be tested periodically on a schedule acceptable to the authority having jurisdiction to ensure the systems are maintained in proper operating condition.

(C) **Battery Systems Maintenance.** Where battery systems or unit equipment are involved, including batteries used for starting, control, or ignition in auxiliary engines, the authority having jurisdiction shall require periodic maintenance.

(D) **Written Record.** A written record shall be kept of such tests and maintenance.

(E) **Testing Under Load.** Means for testing all emergency lighting and power systems during maximum anticipated load conditions shall be provided.

Informational Note: For information on testing and maintenance of emergency power supply systems (EPSSs), see NFPA 110-2013, Standard for Emergency and Standby Power Systems.

##### 700.4. Capacity.

(A) **Capacity and Rating.** An emergency system shall have adequate capacity and rating for all loads to be operated simultaneously. The emergency system equipment shall be suitable for the maximum available fault current at its terminals.

(B) **Selective Load Pickup, Load Shedding, and Peak Load Shaving.** The alternate power source shall be permitted to supply emergency, legally required standby, and optional standby system loads where the source has adequate capacity or

where automatic selective load pickup and load shedding is provided as needed to ensure adequate power to (1) the emergency circuits; (2) the legally required standby circuits; and (3) the optional standby circuits, in that order of priority. The alternate power source shall be permitted to be used for peak load shaving, provided the above conditions are met.

Peak load shaving operation shall be permitted for satisfying the test requirement of Section 700.3(B), provided all other conditions of Section 700.3 are met. A portable or temporary alternate source shall be available whenever the emergency generator is out of service for major maintenance or repair.

##### 700.5. Transfer Equipment.

(A) **General.** Transfer equipment, including automatic transfer switches, shall be automatic and identified for emergency use and approved by the authority having jurisdiction. Transfer equipment shall be designed and installed to prevent the inadvertent interconnection of normal and emergency sources of supply in any operation of the transfer equipment. Transfer equipment and electric power production systems installed to permit operation in parallel with the normal source shall meet the requirements of article 705.

(B) **Bypass Isolation Switches.** Means shall be permitted to bypass and isolate the transfer equipment. Where bypass isolation switches are used, inadvertent parallel operation shall be avoided.

(C) **Automatic transfer switches** shall be electrically operated and mechanically held. Automatic transfer switches, rated 1000 VAC and below, shall be listed for emergency system use.

(D) **Use.** Transfer equipment shall supply only emergency loads.

**700-6. Signals.** Audible and visual signal devices shall be provided, where practicable, for the following purposes described in 700.6(A) through (D).

(A) **Derangement.** To indicate derangement of the emergency source.

(B) **Carrying Load.** To indicate that the battery is carrying load.

(C) **Not Functioning.** To indicate that the battery charger is not functioning.

(D) **Ground Fault.** To indicate a ground fault in solidly grounded wye emergency systems of more than 150 volts to ground and circuit protective devices rated 1000 amperes or more. The sensor for the ground-fault signal devices shall be located at, or ahead of, the main system disconnecting means for the emergency source, and the maximum setting of the signal devices shall be for a ground-fault current of 1200 amperes. Instructions on the course of action to be taken in event of indicated ground fault shall be located at or near the sensor location.

Informational Note: For signals for generator sets, see NFPA 110-2013, Standard for Emergency and Standby Power Systems

##### 700.7. Signs.

(A) **Emergency Sources.** A sign shall be placed at the service entrance equipment indicating type and location of on-site emergency power sources.

Exception: A sign shall not be required for individual unit equipment as specified in Section 700-12(F).

(B) **Grounding.** Where removal of a grounding or bonding connection in the normal power source equipment interrupts the grounding electrode conductor connection to the alternate power source(s) grounded conductor, a warning sign shall be installed at the normal power source equipment stating:

#### WARNING

**SHOCK HAZARD EXISTS IF GROUNDING ELECTRODE CONDUCTOR OR BONDING JUMPER CONNECTION IN THIS EQUIPMENT IS REMOVED WHILE ALTERNATE SOURCE(S) IS ENERGIZED.**

The warning sign(s) or label(s) shall comply with 110.21(B).

##### 700.8

**Emergency Sources.** A listed SPD shall be installed in or on all emergency systems switchboards and panelboards.

#### II. Circuit Wiring

##### 700-10. Wiring, Emergency System.

(A) **Identification.** All boxes and enclosures (including transfer switches, generators, and power panels) for emergency circuits shall be permanently marked so they will be readily identified as a component of an emergency circuit or system.

(B) **Wiring.** Wiring of two or more emergency circuits supplied from the same source shall be permitted in the same raceway, cable, box, or cabinet. Wiring from an emergency source distribution overcurrent protection to emergency loads shall be kept entirely independent of all other wiring and equipment, unless otherwise permitted in 700.10(B) (1) through (5):

# Emergency lighting

## National electrical code

3

- (1) Wiring from the normal power source located in transfer equipment enclosures.
- (2) Wiring supplied from two sources in exit or emergency luminaires
- (3) Wiring from two sources in a listed load control relay supplying exit or emergency luminaires, or in a common junction box, attached to exit or emergency luminaires
- (4) Wiring within a common junction box attached to unit equipment, containing only the branch circuit supplying the unit equipment and the emergency circuit supplied by the unit equipment.

- (5) Wiring from an emergency source to supply emergency and other loads in accordance with 700.10(B)(5)a, b, c, and d as follows:
  - a. Separate vertical switchgear sections or separate vertical switchboard sections, with or without a common bus, or individual disconnects mounted in separate enclosures shall be used to separate emergency loads from all other loads.
  - b. The common bus of separate sections of the switchgear, separate sections of the switchboard, or the individual enclosures shall be permitted to be supplied by single or multiple feeders without overcurrent protection at the source.

Exception to (5)b: Overcurrent protection shall be permitted at the source or for the equipment, provided the overcurrent protection complies with the requirements of 700.28.

- c. Legally required and optional standby circuits shall not originate from the same vertical switchboard section, panel board enclosure, or individual disconnect enclosure as emergency circuits.
- d. It shall be permissible to utilize single or multiple feeders to supply distribution equipment between an emergency source and the point where the combination of emergency, legally required, or optional loads are separated.

**(C) Wiring Design and Location.** Emergency wiring circuits shall be designed and located to minimize the hazards that might cause failure due to flooding, fire, icing, vandalism, and other adverse conditions.

**(D) Fire Protection.** Emergency systems shall meet the following additional requirements (D)(1) through (D)(3) in assembly occupancies for not less than 1000 persons or in buildings above 23 m (75 ft) in height.

Informational Note: For the definition of Occupancy Classification, see Section 6.1 of NFPA 101-2009, Life Safety Code

- (1) Feeder-circuit wiring** shall meet one of the following conditions:
  - (1) Be installed in spaces or areas that are fully protected by an approved automatic fire suppression system.
  - (2) Be listed electrical circuit protective system with a minimum 2-hour fire rating. Informational note: UL guide information for electrical circuit protective systems (FHT) contains information on proper installation requirements to maintain the fire rating
  - (3) Be protected by a listed thermal barrier system for electrical system components with a minimum 2-hour fire rating.
  - (4) Be protected by a listed fire-rated assembly that has a minimum fire rating of 2 hours and contains only emergency wiring circuits
  - (5) Be encased in a minimum of 50 mm (2 in) of concrete
- (2) Feeder-Circuit Equipment.** Equipment for feeder circuits (including transfer switches, transformers, panel boards) shall be either located in spaces fully protected by approved automatic fire suppression systems (including sprinklers and carbon dioxide systems) or in spaces with a 2-hour fire resistance rating.
- (3) Generator Control Wiring.** Control conductors installed between the transfer equipment and the emergency generator shall be kept entirely independent of all other wiring and shall meet the conditions of 700.10(D)(1)

### III. Sources of Power

**700.12. General Requirements.** Current supply shall be such that, in the event of failure of the normal supply to, or within, the building or group of buildings concerned, emergency lighting, emergency power, or both will be available within the time required for the application but not to exceed 10 seconds. The supply system for emergency purposes, in addition to the normal services to the building and meeting the general requirements of this section, shall be one or more of the types of systems described in 700.12(A) through (D) below. Unit equipment in accordance with Section 700.12(E) shall satisfy the applicable requirements of this article.

In selecting an emergency source of power, consideration shall be given to the occupancy and the type of service to be rendered, whether of minimum duration, as for evacuation of a theater, or longer duration, as for supplying emergency power and lighting due to an indefinite period of current failure from trouble either inside or outside the building.

Equipment shall be designed and located to minimize the hazards that might cause complete failure due to flooding, fires, icing, and vandalism. Equipment for sources of power as described in Sections 700.12(A) through (E) where located within assembly occupancies for greater than 1000 persons or in buildings above 23 m (75 ft) in height with any of the following occupancy classes: assembly, educational, residential, detention and correctional, business, and mercantile, shall be installed either in spaces fully protected by approved automatic fire suppression systems (sprinklers, carbon dioxide systems, and so forth), or in spaces with a 1-hour fire rating.

Informational note No. 1: For definition of Occupancy Classification, see Section 6.1 of NFPA 101-2012, Life Safety Code.

Informational note No. 2: For further information, see ANSI/IEEE 493-2007, Recommended

Practice for the Design of Reliable Industrial and Commercial Power Systems.

#### **(A) Storage Battery.**

Storage batteries used as source of power for emergency systems shall be of suitable rating and capacity to supply and maintain the total load for a period of 1-1/2 hours minimum, without the voltage applied to the load falling below 87-1/2 percent of normal. Batteries, whether of the acid or alkali type, shall be designed and constructed to meet the requirements of emergency service and shall be compatible with the charger for that particular installation.

For a sealed battery, the container shall not be required to be transparent. However, for the lead acid battery that requires water additions, transparent or translucent containers shall be furnished. Automotive-type batteries shall not be used.

An automatic battery charging means shall be provided.

#### **(B) Generator Set.**

**(1) Prime Mover-Driven.** For a generator set driven by a prime mover acceptable to the authority having jurisdiction and sized in accordance with Section 700-4. Means shall be provided for automatically starting the prime mover on failure of the normal service and for automatic transfer and operation of all required electrical circuits. A time-delay feature permitting a 15-minute setting shall be provided to avoid retransfer in case of short-time reestablishment of the normal source.

**(2) Internal Combustion Engines as Prime Movers.** Where internal combustion engines are used as the prime mover an on-site fuel supply shall be provided with an on-premise fuel supply sufficient for not less than 2 hours full-demand operation of the system. Where power is needed for the operation of the fuel transfer pumps to deliver fuel to a generator set dry tank, this pump shall be connected to the emergency power system.

**(3) Dual Supplies.** Prime movers shall not be solely dependent upon a public utility gas system for their fuel supply or municipal water supply for their cooling systems. Means shall be provided for automatically transferring from one fuel supply to another where dual fuel supplies are used.

**Exception:** Where acceptable to the authority having jurisdiction, the use of other than on-site fuels shall be permitted where there is a low probability of a simultaneous failure of both the off-site fuel delivery system and power from the outside electrical utility company.

**(4) Where a storage battery is used for control or signal power, or as the means of starting the prime mover, it shall be suitable for the purpose and shall be equipped with an automatic charging means independent of the generator set. Where the battery charger is required for the operation of the generator set, it shall be connected to the emergency system. Where power is required for the operation of dampers used to ventilate the generator set, the dampers shall be connected to the emergency system.**

**(5) Auxiliary Power Supply.** Generator sets that require more than 10 seconds to develop power shall be permitted is an auxiliary power supply energizes the emergency system until the generator can pick up the load.

**(6) Outdoor Generator Sets.** Where an outdoor housed generator set is equipped with a readily accessible disconnecting means in accordance with 445.18, and the disconnecting means is located within sight of the building or structure supplied, an additional disconnecting means shall not be required where ungrounded conductors serve or pass through the building or structure. Where the generator supply conductors terminate at a disconnecting means in or on a building or structure, the disconnecting means shall meet the requirements of 225.36.

**Exception:** For installations under single management where conditions of maintenance and supervision ensure that only qualified persons will monitor and service the installation and where documented safe switching procedures are established and maintained for disconnection, the generator set disconnecting means shall not be required to be located within sight of the building of structure served.

**(C) Uninterruptible Power Supplies.** Uninterruptible power supplies used to provide power for emergency systems shall comply with the applicable provisions of Sections 700-12(A) and (B).

**(D) Separate Service.** Where acceptable to the authority having jurisdiction as suitable for use as an emergency source of power, an additional service shall be permitted.

This service shall be in accordance with the applicable provisions of Article 230 and following additional requirements.

- (1) Separate overhead service conductors, service drops, underground service conductors, or service laterals shall be installed
- (2) The service conductors for the separate service shall be installed sufficiently remote electrically and physically from any other service conductors to minimize the possibility of simultaneous interruption of supply

**(E) Fuel Cell System.** Fuel Cell Systems used as a source of power for emergency systems shall be of suitable rating and capacity to supply and maintain the total load for not less than 2 hours of full demand operation.

Installation of a fuel cell system shall meet the requirements of Parts II through VIII of Article 692. Where a single fuel cell system serves as the normal supply for the building or group of buildings concerned, it shall not serve as the sole source of power for the emergency standby system.

**(F) Unit Equipment.**

- (1) Components of Unit Equipment. Individual unit equipment for emergency illumination shall consist of the following:
  - (1) A rechargeable battery
  - (2) A battery charging means
  - (3) Provisions for one or more lamps mounted on the equipment, or shall be permitted to have terminals for remote lamps, or both and
  - (4) A relaying device arranged to energize the lamps automatically upon failure of the supply to the unit equipment.

**(2) Installation of Unit Equipment.** Unit equipment shall be installed in accordance with 700.12(F)(2)(1) through (6).

(1) The batteries shall be of suitable rating and capacity to supply and maintain at not less than 87-1/2 percent of the nominal battery voltage for the total lamp load associated with the unit for a period of at least 1-1/2 hours, or the unit equipment shall supply and maintain not less than 60 percent of the initial emergency illumination for a period of at least 1-1/2 hours. Storage batteries, whether of the acid or alkali type, shall be designed and constructed to meet the requirements of emergency service.

(2) Unit equipment shall be permanently fixed in place (i.e., not portable) and shall have all wiring to each unit installed in accordance with the requirements of any of the wiring methods in Chapter 3. Flexible cord and plug connection shall be permitted, provided that the cord does not exceed 900 mm (3 ft) in length.

(3) The branch circuit feeding the unit equipment shall be the same branch circuit as that serving the normal lighting in the area and connected ahead of any local switches.

Exception : In a separate and uninterrupted area supplied by a minimum of three normal lighting circuits, a separate branch circuit for unit equipment shall be permitted if it originates from the same panelboard as that of the normal lighting circuits and is provided with a lock-on feature.

(4) The branch circuit that feeds unit equipment shall be clearly identified at the distribution panel.

(5) Emergency luminaire's (illumination fixtures) that obtain power from a unit equipment and are not part of the unit equipment shall be wired to the unit equipment as required by Section 700-10 and by one of the wiring methods of Chapter 3.

(6) Remote heads providing lighting for the exterior of an exit door shall be permitted to be supplied by the unit equipment serving the area immediately inside the exit door

## IV. Emergency System Circuits for Lighting and Power

### 700.15.

**Loads on Emergency Branch Circuits.** No appliances and no lamps, other than those specified as required for emergency use, shall be supplied by emergency lighting circuits.

### 700.16.

**Emergency illumination.** Emergency illumination shall include all required means of egress lighting, illuminated exit signs, and all other lights specified as necessary to provide required illumination.

Emergency lighting systems shall be designed and installed so that the failure of any individual lighting element, such as the burning out of a light bulb, cannot leave in total darkness any space that requires emergency illumination.

Where high-intensity discharge lighting such as high- and low-pressure sodium mercury vapor, and metal halide is used as the sole source of normal illumination, the emergency lighting system shall be required to operate until normal illumination has been restored.

Where an emergency system is installed, emergency illumination shall be provided in the area of the disconnecting means required by 225.31 and 230.70, as applicable, where the disconnecting means are installed indoors.

Exception: Where alternative means that ensure the emergency lighting illumination level is maintained shall be permitted.

**700.17. Branch Circuits for Emergency Lighting.** Branch circuits that supply emergency lighting shall be installed to provide service from a source complying with Section 700-12 when the normal supply for lighting is interrupted. Such installations shall provide either one of the following:

- (1) An emergency lighting supply, independent of the normal lighting supply, with provisions for automatically transferring the emergency lights upon the event of failure of the normal lighting branch circuit
- (2) Two or more branch circuits supplied from separate and complete systems with independent power sources. One of the two power sources and systems shall be part of the emergency system and the other shall be permitted to be part of the normal power source and system. Each system shall provide sufficient power for emergency lighting purposes.

Unless both systems are used for regular lighting purposes and are both kept lighted, means shall be provided for automatically energizing either system upon failure of the other. Either or both systems shall be permitted to be a part of the general lighting of the protected occupancy if circuits supplying lights for emergency illumination are installed in accordance with other sections of this article.

**700.18. Circuits for Emergency Power.** For branch circuits that supply equipment classed as emergency, there shall be an emergency supply source to which the load will be transferred automatically upon the failure of the normal supply.

### V. Control—Emergency Lighting Circuits

**700.19. Multiwire Branch Circuits.** The branch circuit serving emergency lighting and power circuits shall not be part of a multiwire branch circuit.

**700.20. Switch Requirements.** The switch or switches installed in emergency lighting circuits shall be arranged so that only authorized persons will have control of emergency lighting.

Exception No. 1: Where two or more single-throw switches are connected in parallel to control a single circuit, at least one of these switches shall be accessible only to authorized persons.

Exception No. 2: Additional switches that act only to put emergency lights into operation but not disconnect them shall be permissible.

Switches connected in series or 3- and 4-way switches shall not be used.

**700.21. Switch Location.** All manual switches for controlling emergency circuits shall be in locations convenient to authorized persons responsible for their actuation. In facilities covered by Articles 518 and 520, a switch for controlling emergency lighting systems shall be located in the lobby or at a place conveniently accessible thereto. In no case shall a control switch for emergency lighting be placed in a motion-picture projection booth or on a stage or platform.

Exception: Where multiple switches are provided, one such switch shall be permitted in such locations where arranged so that it can energize the circuit only, but cannot deenergize the circuit.

**700.22. Exterior Lights.** Those lights on the exterior of a building that are not required for illumination when there is sufficient daylight shall be permitted to be controlled by an automatic light-actuated device.

**700.23 Dimmer Systems.** A dimmer or relay system containing more than one dimmer or relay and listed for use in emergency systems shall be permitted to be used as a control device for energizing emergency lighting circuits. Upon failure of normal power, the dimmer or relay system shall be permitted to selectively energize only those branch circuits required to provide minimum emergency illumination. All branch circuits supplied by the dimmer or relay system cabinet shall comply with the wiring methods of Article 700.

**700.24 Automatic Load Control Relay.** Where emergency illumination is provided by one or more directly controlled luminaires that respond to an external control input to bypass normal control upon loss of normal power, such luminaires and external bypass controls shall be individually listed for use in emergency systems.

**700.25 Automatic Load Control Relay.** If an emergency lighting load is automatically energized upon loss of the normal supply, a listed automatic load control relay shall be permitted to energize the load. The load control relay shall not be used as transfer equipment.



# Emergency lighting

## National electrical code

### VI. Overcurrent Protection

**700-26. Accessibility.** The branch-circuit overcurrent devices in emergency circuits shall be accessible to authorized persons only.

**700-27. Ground-Fault Protection of Equipment.** The alternate source for emergency systems shall not be required to have ground-fault protection of equipment with automatic disconnecting means. Ground-fault indication of the emergency source shall be provided in accordance with 700.6(D) if ground-fault protection of equipment with automatic disconnecting means is not provided.

Exception: Selective coordination shall not be required between two overcurrent devices located in series if no loads are connected in parallel with the downstream device.

**National Electrical Code® 2014 National Electrical Code® is a registered trademark of the National Fire Protection Association.**

3

# Emergency lighting

## Life safety code

### 7.8 Illumination of Means of Egress.

#### 7.8.1 General.

**7.8.1.1\*** Illumination of means of egress shall be provided in accordance with Section 7.8 for every building and structure where required in Chapters 11 through 43. For the purposes of this requirement, exit access shall include only designated stairs, aisles, corridors, ramps, escalators, and passageways leading to an exit. For the purposes of this requirement, exit discharge shall include only designated stairs, aisles, corridors, ramps, escalators, walkways, and exit passageways leading to a public way.

**7.8.1.2** Illumination of means of egress shall be continuous during the time that the conditions of occupancy require that the means of egress be available for use, unless otherwise provided in 7.8.1.2.2.

**7.8.1.2.1** Artificial lighting shall be employed at such locations and for such periods of time as are necessary to maintain the illumination to the minimum criteria values herein specified.

**7.8.1.2.2** Unless prohibited by Chapters 11 through 43, automatic lighting control devices shall be permitted to temporarily turn off the illumination within the means of egress, provided that each lighting control device complies with all of the following:

- (1) In new installations, the lighting control device is listed.
- (2) The lighting control device is equipped to automatically energize the controlled lights upon loss of normal power and is evaluated for this purpose.
- (3) Illumination timers are provided and are set for a minimum 15-minute duration.
- (4) The lighting control device is activated by any occupant movement in the area served by the lighting units.
- (5) In new installations, the lighting control device is activated by activation of the building fire alarm system, if provided.
- (6) The lighting control device does not turn off any lights relied upon for activation of photoluminescent exit signs or path markers.
- (7) The lighting control device does not turn off any battery equipped emergency luminaires, unit equipment, or exit signs.

**7.8.1.2.3\*** Energy-saving sensors, switches, timers, or controllers shall be approved and shall not compromise the continuity of illumination of the means of egress required by 7.8.1.2.

**7.8.1.3\*** The floors and other walking surfaces within an exit and within the portions of the exit access and exit discharge designated in 7.8.1.1 shall be illuminated as follows:

- (1) During conditions of stair use, the minimum illumination for new stairs shall be at least 10 ft-candle (108 lux), measured at the walking surfaces.
- (2) The minimum illumination for floors and other walking surfaces, other than new stairs during conditions of stair use, shall be to values of at least 1 ft-candle (10.8 lux), measured at the floor.
- (3) In assembly occupancies, the illumination of the walking surfaces of exit access shall be at least 0.2 ft-candle (2.2 lux) during periods of performances or projections involving directed light.
- (4)\*The minimum illumination requirements shall not apply where operations or processes require low lighting levels.

**7.8.1.4\*** Required illumination shall be arranged so that the failure of any single lighting unit does not result in an illumination level of less than 0.2 ft-candle (2.2 lux) in any designated area.

**7.8.1.5** The equipment or units installed to meet the requirements of Section 7.10 also shall be permitted to serve the function of illumination of means of egress, provided that all requirements of Section 7.8 for such illumination are met.

#### 7.8.2 Sources of Illumination.

**7.8.2.1\*** Illumination of means of egress shall be from a source considered reliable by the authority having jurisdiction.

**7.8.2.2** Battery-operated electric lights and other types of portable lamps or lanterns shall not be used for primary illumination of means of egress. Battery-operated electric lights shall be permitted to be used as an emergency source to the extent permitted under Section 7.9.

### 7.9 Emergency Lighting.

#### 7.9.1 General.

**7.9.1.1\*** Emergency lighting facilities for means of egress shall be provided in accordance with Section 7.9 for the following:

- (1) Buildings or structures where required in Chapters 11 through 43
- (2) Underground and limited access structures as addressed in Section 11.7
- (3) High-rise buildings as required by other sections of this Code
- (4) Doors equipped with delayed-egress locks
- (5) Stair shafts and vestibules of smokeproof enclosures, for which the following also apply:
  - (a) The stair shaft and vestibule shall be permitted to include a standby generator that is installed for the smokeproof enclosure mechanical ventilation equipment.
  - (b) The standby generator shall be permitted to be used for the stair shaft and vestibule emergency lighting power supply.
- (6) New access-controlled egress doors in accordance with 7.2.1.6.2.

**7.9.1.2** For the purposes of 7.9.1.1, exit access shall include only designated stairs, aisles, corridors, ramps, escalators, and passageways leading to an exit. For the purposes of 7.9.1.1, exit discharge shall include only designated stairs, ramps, aisles, walkways, and escalators leading to a public way.

**7.9.1.3** Where maintenance of illumination depends on changing from one energy source to another, a delay of not more than 10 seconds shall be permitted.

#### 7.9.2 Performance of System.

**7.9.2.1** Emergency illumination shall be provided for a minimum of 1-1/2 hours in the event of failure of normal lighting.

**7.9.2.1.1 Emergency lighting** facilities shall be arranged to provide initial illumination that is not less than an average of 1 ft-candle (10.8 lux) and, at any point, not less than 0.1 ft-candle (1.1 lux), measured along the path of egress at floor level.



**7.9.2.1.2 Illumination levels** shall be permitted to decline to not less than an average of 0.6 ft-candle (6.5 lux) and, at any point, not less than 0.06 ft-candle (0.65 lux) at the end of 1-1/2 hours.

**7.9.2.1.3 The maximum-to-minimum** illumination shall not exceed a ratio of 40 to 1.

**7.9.2.2** New emergency power systems for emergency lighting shall be at least Type 10, Class 1.5, Level 1, in accordance with NFPA110, Standard for Emergency and Standby Power Systems.

**7.9.2.3\*** The emergency lighting system shall be arranged to provide the required illumination automatically in the event of any interruption of normal lighting due to any of the following:

- (1) Failure of a public utility or other outside electrical power supply
- (2) Opening of a circuit breaker or fuse
- (3) Manual act(s), including accidental opening of a switch controlling normal lighting facilities

**7.9.2.4** Emergency generators providing power to emergency lighting systems shall be installed, tested, and maintained in accordance with NFPA 110, Standard for Emergency and Standby Power Systems. Stored electrical energy systems, where required in this Code, other than battery systems for emergency luminaires in accordance with 7.9.2.5, shall be installed and tested in accordance with NFPA 111, Standard on Stored Electrical Energy Emergency and Standby Power Systems.

**7.9.2.5** Unit equipment and battery systems for emergency luminaires shall be listed to ANSI/UL 924, Standard for Emergency Lighting and Power Equipment.

**7.9.2.6\*** Existing battery-operated emergency lights shall use only reliable types of rechargeable batteries provided with suitable facilities for maintaining them in properly charged condition. Batteries used in such lights or units shall be approved for their intended use and shall comply with NFPA 70, National Electrical Code.

**7.9.2.7** The emergency lighting system shall be either continuously in operation or shall be capable of repeated automatic operation without manual intervention.

### 7.9.3 Periodic Testing of Emergency Lighting Equipment.

**7.9.3.1** Required emergency lighting systems shall be tested in accordance with one of the three options offered by 7.9.3.1.1, 7.9.3.1.2, or 7.9.3.1.3.

**7.9.3.1.1** Testing of required emergency lighting systems shall be permitted to be conducted as follows:

- (1) Functional testing shall be conducted monthly, with a minimum of 3 weeks and a maximum of 5 weeks between tests, for not less than 30 seconds, except as otherwise permitted by 7.9.3.1.1(2).
- (2)\* The test interval shall be permitted to be extended beyond 30 days with the approval of the authority having jurisdiction.
- (3) Functional testing shall be conducted annually for a minimum of 1 1/2 hours if the emergency lighting system is battery powered.
- (4) The emergency lighting equipment shall be fully operational for the duration of the tests required by 7.9.3.1.1(1) and (3).
- (5) Written records of visual inspections and tests shall be kept by the owner for inspection by the authority having jurisdiction.

**7.9.3.1.2** Testing of required emergency lighting systems shall be permitted to be conducted as follows:

- (1) Self-testing/self-diagnostic battery-operated emergency lighting equipment shall be provided.
- (2) Not less than once every 30 days, self-testing/self-diagnostic battery-operated emergency lighting equipment shall automatically perform a test with a duration of a minimum of 30 seconds and a diagnostic routine.
- (3) Self-testing/self-diagnostic battery-operated emergency lighting equipment shall indicate failures by a status indicator.
- (4) A visual inspection shall be performed at intervals not exceeding 30 days.
- (5) Functional testing shall be conducted annually for a minimum of 1-1/2 hours.
- (6) Self-testing/self-diagnostic battery-operated emergency lighting equipment shall be fully operational for the duration of the 1 1/2-hour test.
- (7) Written records of visual inspections and tests shall be kept by the owner for inspection by the authority having jurisdiction.

**7.9.3.1.3** Testing of required emergency lighting systems shall be permitted to be conducted as follows:

- (1) Computer-based, self-testing/self-diagnostic battery-operated emergency lighting equipment shall be provided.
- (2) Not less than once every 30 days, emergency lighting equipment shall automatically perform a test with a duration of a minimum of 30 seconds and a diagnostic routine.
- (3) The emergency lighting equipment shall automatically perform annually a test for a minimum of 1 1/2 hours.
- (4) The emergency lighting equipment shall be fully operational for the duration of the tests required by 7.9.3.1.3(2) and (3).
- (5) The computer-based system shall be capable of providing a report of the history of tests and failures at all times.

### 7.10 Marking of Means of Egress.

#### 7.10.1 General.

**7.10.1.1 Where Required.** Means of egress shall be marked in accordance with Section 7.10 where required in Chapters 11 through 43.

#### 7.10.1.2 Exits.

**7.10.1.2.1\*** Exits, other than main exterior exit doors that obviously and clearly are identifiable as exits, shall be marked by an approved sign that is readily visible from any direction of exit access.

#### 7.10.1.2.2\*

Horizontal components of the egress path within an exit enclosure shall be marked by approved exit or directional exit signs where the continuation of the egress path is not obvious.

**7.10.1.3 Exit Door Tactile Signage.** Tactile signage shall be provided to meet all of the following criteria, unless otherwise provided in 7.10.1.4:

- (1) Tactile signage shall be located at each exit door requiring an exit sign.
- (2) Tactile signage shall read as follows: EXIT.
- (3) Tactile signage shall comply with ICC/ANSI A117.1, American National Standard for Accessible and Usable Buildings and Facilities.

**7.10.1.4 Existing Exemption.** The requirements of 7.10.1.3 shall not apply to existing buildings, provided that the occupancy classification does not change.

#### 7.10.1.5 Exit Access.

**7.10.1.5.1** Access to exits shall be marked by approved, readily visible signs in all cases where the exit or way to reach the exit is not readily apparent to the occupants.

**7.10.1.5.2\*** New sign placement shall be such that no point in an exit access corridor is in excess of the rated viewing distance or 100 ft (30 m), whichever is less, from the nearest sign.

**7.10.1.6\* Floor Proximity Exit Signs.** Where floor proximity exit signs are required in Chapters 11 through 43, such signs shall comply with 7.10.3, 7.10.4, 7.10.5, and 7.10.6 for externally illuminated signs and 7.10.7 for internally illuminated signs. Such signs shall be located near the floor level in addition to those signs required for doors or corridors. The bottom of the sign shall be not less than 6 in. (150 mm), but not more than 18 in. (455 mm), above the floor. For exit doors, the sign shall be mounted on the door or adjacent to the door, with the nearest edge of the sign within 4 in. (100 mm) of the door frame.

**7.10.1.7\* Floor Proximity Egress Path Marking.** Where floor proximity egress path marking is required in Chapters 11

through 43, an approved floor proximity egress path marking system that is internally illuminated shall be installed within 18 in. (455 mm) of the floor. Floor proximity egress path marking systems shall be listed in accordance with ANSI/UL 1994, Standard for Luminous Egress Path Marking Systems. The system shall provide a visible delineation of the path of travel along the designated exit access and shall be essentially continuous, except as interrupted by doorways, hallways, corridors, or other such architectural features. The system shall operate continuously or at any time the building fire alarm system is activated. The activation, duration, and continuity of operation of the system shall be in accordance with 7.9.2. The system shall be maintained in accordance with the product manufacturing listing.

**7.10.1.8\* Visibility.** Every sign required in Section 7.10 shall be located and of such size, distinctive color, and design that it is readily visible and shall provide contrast with decorations, interior finish, or other signs. No decorations, furnishings, or equipment

# Emergency lighting

## Life safety code

3

that impairs visibility of a sign shall be permitted. No brightly illuminated sign (for other than exit purposes), display, or object in or near the line of vision of the required exit sign that could detract attention from the exit sign shall be permitted.

**7.10.1.9 Mounting Location.** The bottom of new egress markings shall be located at a vertical distance of not more than 6 ft 8 in. (2030 mm) above the top edge of the egress opening intended for designation by that marking. Egress markings shall be located at a horizontal distance of not more than the required width of the egress opening, as measured from the edge of the egress opening intended for designation by that marking to the nearest edge of the marking.

### 7.10.2 Directional Signs.

**7.10.2.1\*** A sign complying with 7.10.3, with a directional indicator showing the direction of travel, shall be placed in every location where the direction of travel to reach the nearest exit is not apparent.

**7.10.2.2** Directional exit signs shall be provided within horizontal components of the egress path within exit enclosures as required by 7.10.1.2.2.

### 7.10.3\* Sign Legend.

**7.10.3.1** Signs required by 7.10.1 and 7.10.2 shall read as follows in plainly legible letters, or other appropriate wording shall be used:

**EXIT**

**7.10.3.2\*** Where approved by the authority having jurisdiction, pictograms in compliance with NFPA 170, Standard for Fire Safety and Emergency Symbols, shall be permitted.

**7.10.4\* Power Source.** Where emergency lighting facilities are required by the applicable provisions of Chapters 11 through 43 for individual occupancies, the signs, other than approved self-luminous signs and listed photoluminescent signs in accordance with 7.10.7.2, shall be illuminated by the emergency lighting facilities. The level of illumination of the signs shall be in accordance with 7.10.6.3 or 7.10.7 for the required emergency lighting duration as specified in 7.9.2.1. However, the level of illumination shall be permitted to decline to 60 percent at the end of the emergency lighting duration.

### 7.10.5 Illumination of Signs.

**7.10.5.1\* General.** Every sign required by 7.10.1.2, 7.10.1.5, or 7.10.8.1, other than where operations or processes require low lighting levels, shall be suitably illuminated by a reliable light source. Externally and internally illuminated signs shall be legible in both the normal and emergency lighting mode.

### 7.10.5.2\* Continuous Illumination.

**7.10.5.2.1** Every sign required to be illuminated by 7.10.6.3, 7.10.7, and 7.10.8.1 shall be continuously illuminated as required under the provisions of Section 7.8, unless otherwise provided in 7.10.5.2.2.

**7.10.5.2.2\*** Illumination for signs shall be permitted to flash on and off upon activation of the fire alarm system.

### 7.10.6 Externally Illuminated Signs.

#### 7.10.6.1\* Size of Signs.

**7.10.6.1.1** Externally illuminated signs required by 7.10.1 and 7.10.2, other than approved existing signs, unless otherwise provided in 7.10.6.1.2, shall read EXIT or shall use other appropriate wording in plainly legible letters sized as follows:

- (1) For new signs, the letters shall be not less than 6 in. (150 mm) high, with the principal strokes of letters not less than 3/4 in. (19 mm) wide.
- (2) For existing signs, the required wording shall be permitted to be in plainly legible letters not less than 4 in. (100 mm) high.
- (3) The word EXIT shall be in letters of a width not less than 2 in. (51 mm), except the letter I, and the minimum spacing between letters shall be not less than 3/8 in. (9.5 mm).
- (4) Sign legend elements larger than the minimum established in 7.10.6.1.1(1) through (3) shall use letter widths, strokes, and spacing in proportion to their height.

**7.10.6.1.2** The requirements of 7.10.6.1.1 shall not apply to marking required by 7.10.1.3 and 7.10.1.7.

#### 7.10.6.2\* Size and Location of Directional Indicator.

**7.10.6.2.1** Directional indicators, unless otherwise provided in 7.10.6.2.2, shall comply with all of the following:

- (1) The directional indicator shall be located outside of the EXIT legend, not less than 3/8

in. (9.5 mm) from any letter.

- (2) The directional indicator shall be of a chevron type, as shown in Figure 7.10.6.2.1.
- (3) The directional indicator shall be identifiable as a directional indicator at a distance of 40 ft (12 m).
- (4) A directional indicator larger than the minimum established for compliance with 7.10.6.2.1(3) shall be proportionately increased in height, width, and stroke.
- (5) The directional indicator shall be located at the end of the sign for the direction indicated.



#### 7.10.6.2.1 Chevron Type Indicator.

**7.10.6.2.2** The requirements of 7.10.6.2.1 shall not apply to approved existing signs.

**7.10.6.3\* Level of Illumination.** Externally illuminated signs shall be illuminated by not less than 5 ft-candles (54 lux) at the illuminated surface and shall have a contrast ratio of not less than 0.5.

### 7.10.7 Internally Illuminated Signs.

**7.10.7.1 Listing.** Internally illuminated signs shall be listed in accordance with ANSI/UL 924, Standard for Emergency Lighting and Power Equipment, unless they meet one of the following criteria:

- (1) They are approved existing signs.
- (2) They are existing signs having the required wording in legible letters not less than 4 in. (100 mm) high.
- (3) They are signs that are in accordance with 7.10.1.3 and 7.10.1.6.

**7.10.7.2\* Photoluminescent Signs.** The face of a photoluminescent sign shall be continually illuminated while the building is occupied. The illumination levels on the face of the photoluminescent sign shall be in accordance with its listing. The charging illumination shall be a reliable light source, as determined by the authority having jurisdiction. The charging light source, shall be of a type specified in the product markings.

### 7.10.8 Special Signs.

#### 7.10.8.1 Sign Illumination.

**7.10.8.1.1** Where required by other provisions of this Code, special signs shall be illuminated in accordance with 7.10.5, 7.10.6.3, and 7.10.7.

**7.10.8.1.2** Where emergency lighting facilities are required by the applicable provisions of Chapters 11 through 43, the required illumination of special signs shall additionally be provided under emergency lighting conditions.

**7.10.8.2 Characters.** Special signs, where required by other provisions of this Code, shall comply with the visual character requirements of ICC/ANSI A117.1, American National Standard for Accessible and Usable Buildings and Facilities.

#### 7.10.8.3\* No Exit.

**7.10.8.3.1** Any door, passage, or stairway that is neither an exit nor a way of exit access and that is located or arranged so that it is likely to be mistaken for an exit shall be identified by a sign that reads as follows:

## NO EXIT

**7.10.8.3.2** The NO EXIT sign shall have the word NO in letters 2 in. (51 mm) high, with a stroke width of 3/8 in. (9.5 mm), and the word EXIT in letters 1 in. (25 mm) high, with the word EXIT below the word NO, unless such sign is an approved existing sign.

**7.10.8.4 Elevator Signs.** Elevators that are a part of a means of egress (see 7.2.13.1) shall have both of the following signs with a minimum letter height of 5/8 in. (16 mm) posted in every elevator lobby:

- (1) \*Signs that indicate that the elevator can be used for egress, including any restrictions on use
- (2) \*Signs that indicate the operational status of elevators

**7.10.8.5\* Evacuation Diagram.** Where a posted floor evacuation diagram is required in Chapters 11 through 43, floor evacuation diagrams reflecting the actual floor arrangement and exit locations shall be posted and oriented in a location and manner acceptable to the authority having jurisdiction.

**7.10.9 Testing and Maintenance.**

**7.10.9.1 Inspection.** Exit signs shall be visually inspected for operation of the illumination sources at intervals not to exceed 30 days or shall be periodically monitored in accordance with 7.9.3.1.3.

**7.10.9.2 Testing.** Exit signs connected to, or provided with, a battery-operated emergency illumination source, where required in 7.10.4, shall be tested and maintained in accordance with 7.9.3.

NFPA 101® Life Safety Code®  
2015 Edition

©2015, NFPA, All Right Reserved  
Life Safety Code® and NFPA 101® are registered trademarks of the National Fire Protection Association, Inc.





# Flood lighting

## FDL series

### LED Floodlight

#### Vapor / Dust Proof Lighting

#### Certifications and standards

- Class I – Division 2, groups A, B, C and D
- Class II – Division 2, groups F and G
  - UL1598 For Marine Locations
  - UL844
  - IP66, Wet location



Contact your Thomas & Betts sales representative to verify classification.



#### Features

- Energy efficient alternative to hazardous location metal halide and high pressure sodium
- Designed for outdoor, hazardous, marine, low-bay and flood applications
- Natural unpainted coat finish standard
- Type V multiple distribution patterns available: frosted film, 16°, 70°, and 120°
- CCT of 5000K
- Selection of mounting style
- Tamper-proof screws
- 5 year warranty
- > 120K Hours (rated lifetime projection L70)

#### Construction

- Cooper-free cast aluminum housing
- Captive stainless steel fasteners and insert
- 24 high-power LED's

#### Electrical

- 55W (6,400 Lumens), 82W (9,000 Lumens), 107W (11,000 Lumens)
- 120-277VAC, 277-480VAC (FDL05 model only)

#### Options

- Mounting: ceiling, pendant, yoke, wall, straight or angled stanchion
- Cord with blunt end
- Lens guard
- Gray, black or white powder coat finish

#### T-Ratings

Model	Rated ambient deg. C	Class I, div 2 operating temperature code	Class II, div 2 operating temperature code
FDL05	50°C	T3C (160°C)	T5 (100°C)
FDL08	50°C	T3C (160°C)	T5 (100°C)
FDL10	50°C	T3C (160°C)	T5 (100°C)

# Flood lighting

## FDL series

### FDL series – Hazlux floodlights LED

<b>FDL</b>	<b>10</b>	<b>UN</b>	<b>Y1</b>	<b>M</b>	<b>LG</b>
1	2	3	4	5	6

#### Ordering information

1 Fixture series	FDL	Hazlux floodlights LED Class I Div 2
2 Lumen	05	6,400 Lumen (55 Watts)
	08	9,000 Lumen (82 Watts)
	10	11,000 Lumen (107 Watts)
3 Voltage	UN	120-277V
	UN2	277-480V (on FDL 05 models only)
4 Mounting style	C1	Ceiling 1/2"
	C2	Ceiling 3/4"
	P2	Pendant 3/4"
	Y1	Yoke mount 1/2"
	B3	Wall mount 1"
	L4	Stanchion 1 1/4"
	L5	Stanchion 1 1/2"
5 Optics	F	Frosted film
	N	Narrow 16° FWHM
	M	Medium 70° FWHM
	W	Wide 120° FWHM
6 Options	LG	Lens guard
	PW	Pre-wired 3ft cord with blunt end*
	GRY	Gray powder coat finish
	BLK	Black powder coat finish
	WHT	White powder coat finish

\*Y1 mount only

#### Equivalent HID (metal halide) WATTS

LED	Metal halide
55	100
82	150
107	250

Note: For Reference Only

#### Dimensions

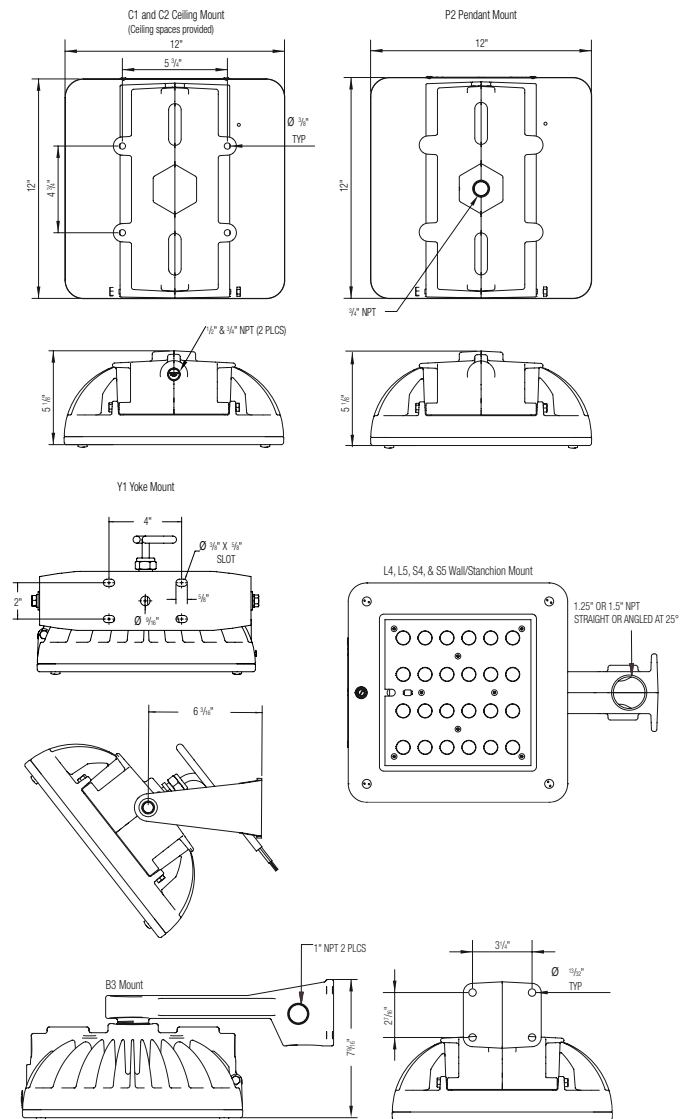

**Ceiling mount**

Reference data		Axial Candela Display	Isocandela Curves
Catalog no.	FDL10UNC1-N	17901	
Luminaire Lumens	12,059	88426	
Input Watt	107	58951	
NEMA Type	2 H x 2 V	29475	
Maximum Candela	117901		
Maximum Candela Angle	OH OV		
Horizontal Beam Angle (50%)	15.3		
Verticle Beam Angle (50%)	15.2		
Horizontal Field Angle (10%)	28.6		
Vertical Field Angle (10%)	28.3		

**Ceiling mount**

Reference data		Axial Candela Display	Isocandela Curves
Catalog no.	FDL10UNC1-M	9539	
Luminaire Lumens	10,714	7155	
Input Watt	107	4770	
NEMA Type	6 H x 6 V	2385	
Maximum Candela	9539.4		
Maximum Candela Angle	OH OV		
Horizontal Beam Angle (50%)	68.2		
Verticle Beam Angle (50%)	68.2		
Horizontal Field Angle (10%)	100.1		
Vertical Field Angle (10%)	100.5		

**Ceiling mount**

Reference data		Axial Candela Display	Isocandela Curves
Catalog no.	FDL10UNC1-W	4241	
Luminaire Lumens	11,025	3181	
Input Watt	107	2121	
NEMA Type	6 H x 6 V	1060	
Maximum Candela	4241		
Maximum Candela Angle	OH -47.5V		
Horizontal Beam Angle (50%)	87.3		
Verticle Beam Angle (50%)	120.2		
Horizontal Field Angle (10%)	106.4		
Vertical Field Angle (10%)	129.6		
Vertical Field Angle (10%)	28.3		

# Flood lighting

## Quick pole assembly

### Quick pole assembly

- Operates in any kind of weather
- Overall length is 10' (3 m)
- Pole trade size is 1½" threaded NPT. Aluminum pole trade size is 2" threaded NPT
- Top pole section is 70" (1.78 m) long
- Lower pole section is 50" (1.27 m) long
- Set screws secure top and bottom section into the quick knuckle

### Quick knuckle assembly

- Rotates 180° (90° left and right) around knuckle's center axis allowing freedom of installation and easy adjustment
- Easy one man operation. After center bolt is loosened, use the pull pin to lock and unlock the assembly
- Pre-fished with tape to ease wiring

### Brackets

- Universal mounting for 2" to 3" angle iron railings
- Quick mounting brackets can be installed inside or outside the guardrails
- Quick knuckle assembly should be mounted above hand rail allowing the pole sections to rotate before final positioning

### Features & benefits

- Sphere shaped, quick knuckle features round edges, preventing injuries and containment build-up of components
- The quick release mechanism is activated using one hand and one pull pin
- The quick pole assembly blocks at a 90° angle when the pull pin reaches the stopper
- All quick knuckle hardware is made of stainless steel
- All mounting brackets hardware are hot dip galvanized

The quick pole assembly blocks at a 90° angle





### Galvanised standard kit

- Overall height of 10' (3 m)
- 1½" NPT treads at both ends
- Installed with two rail mounting brackets

1. Rotating quick knuckle assembly
2. Angle iron mounting brackets allowing the pole section to rotate before final positioning

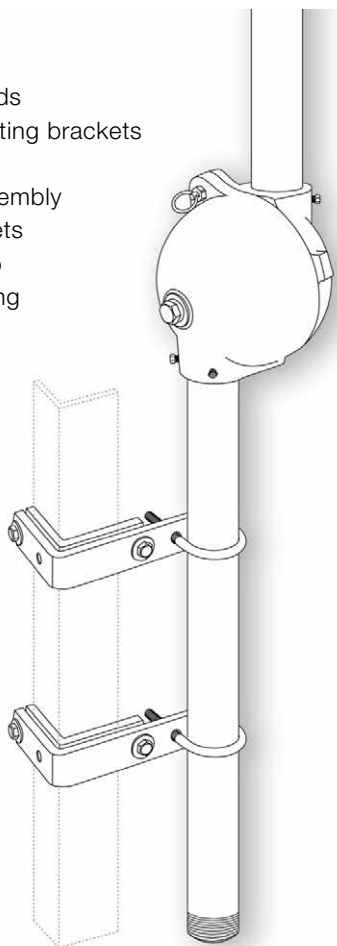

Type Q-P-5-10-N (galvanized steel)  
Type Q-P-A-5-10-N (aluminum)  
Standard kit

### Retrofit kit

- Overall maximum and predetermined height of 10' (3 m) once assembled
- Can be adapted to existing pole
- Upgrades existing assembly with quick and easy maintenance features
- See instruction sheets provided with product for installation details

1. Rotating quick knuckle assembly
2. Tapered adaptor, fits over standard 1¼" or 1½" NPT pipe

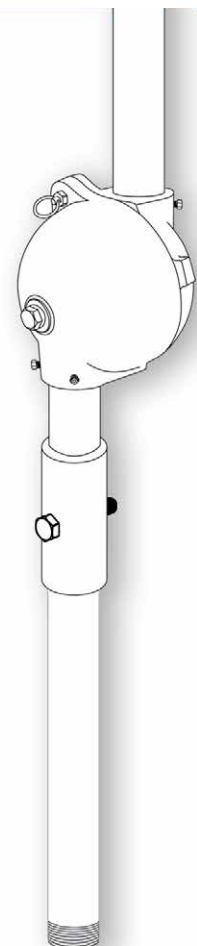

Type RQ-P-5-10-N (galvanized steel)  
Type RQ-P-A-5-10-N (aluminum)  
Retrofit kit

### Safety first

- One person operation
- No ladders or lifts required
- Simplified maintenance
- Hot dipped galvanized steel and aluminum finishes free's up catwalks and walkways during maintenance
- Epoxy coated finishes available
- Suitable for 180km/h winds as per AASHTO LTS-4 2001
- Steel pole treads are treated and protected to prevent galvanic reaction as per AASHTO LTS-4 2001
- CSA certified products
- Maximum connected device weight limit is 70 lbs. (50lb for the light fixture and 20lb for the QuickPole itself).

Both the aluminum and steel have 1½" threaded pipe ends.

Steel pipe is 1.9" OD with tips machined to 1½" NPT. Aluminum pipe is 2 3/8" OD and has a welded coupling on the end to reduce to 1½" NPT. An additional (not supplied) adapter would be needed to fit to 1¼" NPT.



# Flood lighting

## Quick pole assembly

4

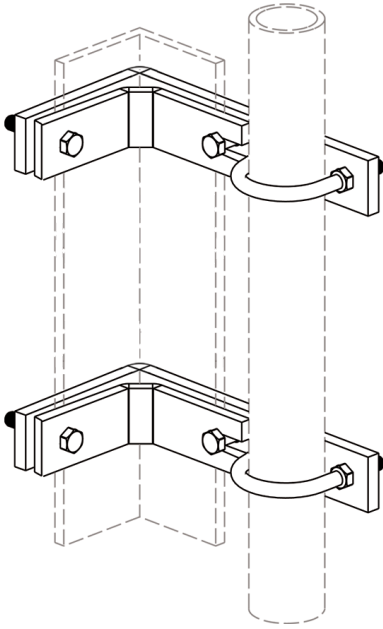

Type AMB-QP-BKT-N  
Type AMB-QP-A-BKT-N (aluminum)  
Universal bracket kit

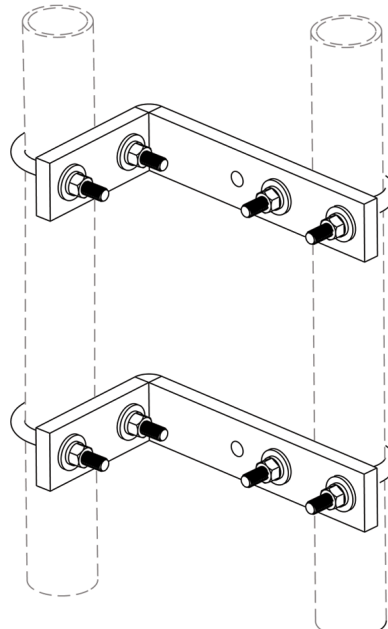

Type RMB-QP-BKT-N  
Type RMB-QP-A-BKT-N (aluminum)  
Universal bracket kit

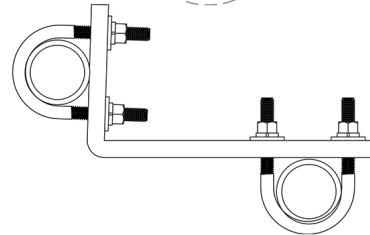
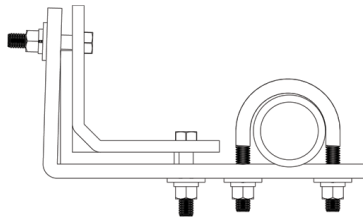

### Universal bracket kit

- Quick bolt-on installation, no welding or drilling
- Can be attached to angle iron guardrails up to 3"
- Can be installed on tubular structures less than 2" O.D.
- Allows the pole sections to rotate before final positioning

### Quick bolt-on installation



# Technical section

## Ignition temperatures and group classifications

### Ignition temperatures and group classifications for flammable gases and vapors

Material	Group	Autoignition Temperature		Material	Group	Autoignition Temperature	
		Degrees F	Degrees C			Degrees F	Degrees C
Acetaldehyde	C	347	175	Diethyl Benzene	D	743–842	395–450
Acetic Acid	D	867	464	Diethyl Ether	C	320	160
Acetic Anhydride	D	600	316	Diethylamine	C	594	312
Acetone	D	869	465	Diethylene Glycol Monobutyl Ether	C	442	228
Acetone Cyanohydrin	D	1270	688	Diethylene Glycol Monomethyl Ether	C	465	241
Acetonitrile	D	975	524	n-n-Dimethyl Aniline	C	700	371
Acetylene	A	581	305	Dimethyl Formamide	D	833	455
Acrolein (Inhibited)	B (C)	455	285	Dimethyl Sulfate	D	370	188
Acrylic Acid	D	820	438	Dimethylamine	C	752	400
Acrylonitrile	D	898	481	1,4-Dioxane	C	356	180
Allyl Alcohol	C	713	378	Dipentene	D	458	237
Allyl Chloride	D	905	485	Dodecene	D	491	255
Alpha-Methyl Styrene	D	1066	574	Du-Isopropylamine	C	600	316
Ammonia	D	928	498	Epichlorohydrin	C	772	411
n-Amyl Acetate	D	680	360	Ethane	D	882	472
Aniline	D	1139	615	Ethanol	D	685	363
Benzene	D	928	498	Ethyl Acetate	D	800	427
Benzyl Chloride	D	1085	585	Ethyl Acetate (Inhibited)	D	702	372
1,3-Butadiene	B (D)	788	420	Ethyl Benzene	D	810	432
Butane	D	550	288	Ethyl Chloride	D	966	519
1-Butanol	D	650	343	Ethyl Formate	D	851	455
2-Butanol	D	761	405	2-Ethyl Hexanol	D	448	231
n-Butyl Acetate	D	790	421	2-Ethyl Hexyl Acrylate	D	485	252
n-Butyl Acrylate (Inhibited)	D	559	293	Ethyl Mercaptan	C	572	300
Butylamine	D	594	312	Ethylamine	D	725	385
Butylene	D	725	385	Ethylene	C	842	450
n-Butyraldehyde	C	425	218	Ethylene Chlorohydrin	D	797	425
n-Butyric Acid	D	830	443	Ethylene Dichloride	D	775	413
Carbon Disulfide	*	194	90	Ethylene Glycol Monobutyl Ether	C	460	238
Carbon Monoxide	C	1128	609	Ethylene Glycol Monobutyl Ether Acetate	C	645	340
Chlorobenzene	D	1099	593	Ethylene Glycol Monobutyl Ether	C	455	235
Cresol	D	1038–1110	559–599	Ethylene Glycol Monobutyl Ether Acetate	C	715	379
Crotonaldehyde	C	450	232	Ethylene Glycol Monomethyl Ether	D	545	285
Cumene	D	795	424	Ethylene Oxide	B (C)	804	429
Cyclohexane	D	473	245	Ethylenediamine	D	725	385
Cyclohexanol	D	572	300	Ethylenimine	C	608	320
Cyclohexanone	D	473	245	2-Ethylehexaldehyde	C	375	191
Cyclohexene	D	471	244	Formaldehyde (Gas)	B	795	429
Cyclopropane	D	938	503	Formic Acid (90%)	D	813	434
p-Cymene	D	817	436	Fuel Oils	D	410–765	210–407
n-Decanol	D	550	288	Furfural	C	600	316
Decene	D	455	235	Furfuryl Alcohol	C	915	490
Di-Isobutyl Ketone	D	745	396	Gasoline	D	536–880	280–471
Di-Isobutylene	D	736	391	Heptane	D	399	204
Di-N-Propylamine	C	570	299	Heptene	D	500	260
Diacetone Alcohol	D	1118	603	Hexane	D	437	225
o-Dichlorobenzene	D	1198	647	2-Hexanone	D	795	424
1,1-Dichloroethane	D	820	438	Hexenes	D	473	245
1,2-Dichloroethylene	D	860	460	Hydrazine	C	74–518	23–270
Dicylopentadiene	C	937	503	Hydrogen	B	968	520

\*Carbon Disulfide has characteristics which require safeguards beyond those required for any of the above groups  
Warning: Table provided as reference only.

# Technical section

## Ignition temperatures and group classifications

### Ignition temperatures and group classifications for flammable gases and vapors (continued)

Material	Group	Autoignition Temperature	
		Degrees F	Degrees C
Hydrogen Cyanide	C	1000	538
Hydrogen Sulfide	C	500	260
Iso-Butyl Acetate	D	790	421
Iso-Octyl Aldehyde	C	387	197
Isoamyl Acetate	D	680	360
Isoamyl Alcohol	D	662	350
Isobutyl Acrylate	D	800	427
Isobutyraldehyde	C	385	196
Isophorone	D	860	460
Isoprene	D	428	220
Isopropyl Acetate	D	860	460
Isopropyl Ether	D	830	443
Isopropylamine	D	756	402
Kerosene	D	410	210
Liquified Petroleum Gas	D	761–842	405–450
Mesityl Oxide	D	652	344
Methane	D	999	537
Methanol	D	725	385
Methyl Acetate	D	850	454
Methyl Acrylate	D	875	468
Methyl Ether	C	662	350
Methyl Ethyl Ketone	D	759	404
Methyl Formal	C	460	238
Methyl Formate	D	840	449
Methyl Isobutyl Ketone	D	840	449
Methyl Isocyanate	D	994	534
Methyl Methacrylate	D	792	422
Methyl N-Amyl Ketone	D	740	393
2-Methyl-1-Propanol	D	780	416
2-Methyl-2-Propanol	D	892	478
Methylamine	D	806	430
Methylcyclohexane	D	482	250
Methylcyclohexanol	D	565	296
Monoethanolamine	D	770	410
Monoisopropanolamine	D	705	374
Monomethyl Aniline	C	900	482
Monomethyl Hydrazine	C	382	194
Morpholine	C	590	310
Naphtha (Coal Tar)	D	531	277
Naphtha (Petroleum)	D	550	288
Nitrobenzene	D	900	482
Nitroethane	C	778	414
Nitromethane	C	785	418
2-Nitropropane	C	802	428
1-Nitropropane	C	789	421
Nonane	D	401	205
Octane	D	403	206
Octene	D	446	230
Pentane	D	470	243
1-Pentanol	D	572	300

Material	Group	Autoignition Temperature	
		Degrees F	Degrees C
2-Pentanone	D	846	452
1-Pentene	D	527	275
Propane	D	842	450
2-Propanol	D	750	399
1-Propanol	D	775	413
Propionaldehyde	C	405	207
Propionic Acid	D	870	466
Propionic Anhydride	D	545	285
N-Propyl Acetate	D	842	450
N-Propyl Ether	C	419	215
Propyl Nitrate	B	347	175
Propylene	D	851	455
Propylene Dichloride	D	1035	537
Propylene Oxide	B (C)	840	449
Pyridine	D	900	482
Styrene	D	914	490
Tetrahydrofuran	C	610	321
Tetrahydronapthalene	D	725	385
Toluene	D	896	480
Turpentine	D	488	253
Unsymmetrical Dimethyl Hydrazine (Udmh)	C	480	249
Valeraldehyde	C	432	222
Vinyl Acetate	D	756	402
Vinyl Chloride	D	882	472
Vinyl Toluene	D	921	494
Vinylidene Chloride	D	1058	570
Xylenes	D	867–984	464–529

Warning: Table provided as reference only.



# Index

Part No.	Page	Part No.	Page
145.0056-H	18	VA3	17
145.0057-H	18	VB0618	33
145.0058-H	18	VB1236	33
DFPLEDS4K434PFT	25	VB1260	33
DL005	13, 18	VB1272	33
DL005EUN0TGC2EU	19	VB2-VIB	17
DL007	13, 18	VB3-VIB	17
DL010	13, 18	VC	32
DL010EUN0R1C2EU	20	VC12H	32
DL010EUN0TGC2EU	19	VC12N	32
DL010EUNOR3C2EU	20	VC2	17
DL015	13, 18	VC3	17
DL015EUN0TGC2EU	19	VGL15R1	17
DL017	13, 18	VGL15R3	17
DL020	13, 18	VGL15R5	17
DL020EUN0R5C2EU	20	VGT15	17
DL020EUN0TGC2EU	19	VGU22	17
FDL05	45	VGU22P	17
FDL08	45	VL4-VIB	17
FDL10	45	VL5-VIB	17
FDL10UNC1-M	47	VR15P	17
FDL10UNC1-N	47	VRA15P	17
FDL10UNC1-W	47	VS4-VIB	17
HLPC-120-FG	18	VS5-VIB	17
HLPC-208-277-FG	18	XFMLEDS5K24UN	28
HV1	17	XFMLEDS5K34UN	28
VA2	17		

# Warranty

## Hazlux VE, VC, and combo series limited warranty

- 1.1 **Hazlux 6, 12 and 24 volt Emergency Lighting Unit Equipment** (excluding lamps and fuses) and exit signs are fully warranted to be free of defects in material and workmanship under normal use for a period of five years from date of installation (see Paragraph 2.1). (For MR16 LED light source, see Paragraph 3.3)
- 1.2 **Hazlux 6, 12 and 24 volt Unit Equipment Batteries** are warranted as follows (Warrant below includes the full warranty on entire unit as called out in Paragraph 1.1–1.2).

**\*Maximum Storage life. Must Be Recharged If Not Placed in Service Or Battery Warranty Void**

Battery type	Life expectancy	Shelf life*	Full warranty	PRO RATA warranty
Sealed Lead-Calcium	8 years	6 months	3 years	3 years
High Temperature Lead-Calcium	8 years	6 months	5 years	3 years
Sealed Nickel-Cadmium	10 years	1 year	5 years	5 years
Nickel-Metal Hydride	10 years	1 year	5 years	5 years

- 2.1 The full warranty period begins on the date of installation or 90 days from date of shipment, whichever date is earlier.
- 2.2 Should a defect appear in the equipment or batteries listed in Paragraphs 1.1–1.2 above within the specified full warranty period, **Hazlux** will repair or replace equipment without charge (see paragraph 3.3). Such repair or replacement shall be the purchaser's exclusive remedy.
- 2.3 The Pro Rata Warranty Period for batteries begins on the date the full warranty period ends.
- 2.4 A battery determined to be defective during the Pro Rata warranty period shall be repaired or replaced at a cost equal to the net price in effect at the time, reduced by the percentage obtained in multiplying 10% by the number of full years remaining in the total warranty period. Such repair or replacement at this adjusted price shall be the purchaser's exclusive remedy.
- 3.1 All warranties are subject to proper installation and maintenance in accordance with the instructions supplied.
- 3.2 Any material deemed defective must be returned, freight prepaid, to the factory for evaluation (see paragraph 5.1-5.3). Any changes in circuitry or components by other than authorized **Thomas & Betts** personnel or its service companies will void the warranty.
- 3.3 All warranties are limited to the repair and/or replacement or parts or equipment, which, upon examination at our plant, are determined to be defective and in our judgement are subject to repair or replacement under warranty. Replacement of lamps and fuses is not included in the warranty except for MR16 LED lamps are warranted to be free of defects in material and workmanship under normal use for a period of five (5) years when purchased and used with **Hazlux** battery units, combination units or remotes. The full warranty period begins on the date of installation or ninety (90) days from the date of shipment, whichever date is earlier.
- 3.4 If new replacement parts are shipped before defective goods are received for evaluation, the replacement parts will be invoiced at the net price in effect at that time. These charges will be credited if, upon receipt and evaluation of goods, a defect is determined. Only replacement parts will be shipped under these circumstances, if field replacement is possible. **FACTORY ONLY RESERVES THE RIGHT TO SHIP NEW UNIT EQUIPMENT FOR REPLACEMENT PURPOSES.** Units returned after installation cannot be restored to 100% saleable condition.
- 4.1 In no event shall **Thomas & Betts** be liable for backcharges of any kind, including, without limitation, labor charges for field repair or late penalties.
- 4.2 This warranty does not cover damages caused by improper maintenance of installation or damage due to installation in areas with other than normal temperatures and environmental conditions per application specifications. **Thomas & Betts** assumes no responsibility for any damage to people, property, apparatus or otherwise resulting from improper installation or maintenance of its emergency lighting unit equipment.
- 4.3 This warranty does not cover damages caused by abuse, fire or Act of God.
- 4.4 In no event shall **Thomas & Betts** be liable for incidental or consequential damages.
- 4.5 The foregoing warranty is in lieu of all other warranties, expressed or implied, or merchantability, fitness for a particular purpose or any other thing. Except as stated in this warranty, **Thomas & Betts** shall not be liable for any defects in, or breach of any contract relating to, the quality of performance of **Hazlux** equipment under any theory of law including, without limitation, contract, negligence, strict liability or misrepresentation.
- 4.6 Warranty coverage shall not apply to any equipment of another manufacturer used in conjunction with **Hazlux** equipment.
- 4.7 Some states do not allow limitation on how long an implied warranty lasts, so the above limitation may not apply to you. Some states do not allow the exclusion or limitation of incidental or consequential damages, so the above limitation or exclusion may not apply to you. This written warranty gives you specific legal rights and you may also have other rights which vary from state to state.
- 5.1 No returned defective materials will be accepted without a returned goods authorization issued in writing by an authorized **Thomas & Betts** employee.
- 5.2 Purchaser is responsible for secure packing of returned materials to provide best possible assurance against damage in shipment.
- 5.3 Defective batteries of any kind must not be returned to **Hazlux** factory without strict adherence to special instructions for handling and shipping. **WARNING** Never ship a refillable wet battery in any type of emergency lighting equipment. Failure to adhere to this policy will void warranty.
- 5.4 Defective goods returned to the factory must be shipped prepaid. **COLLECT RETURNED SHIPMENT WILL BE REFUSED.** Freight charges to return repaired equipment or ship replacement equipment to the purchaser to be paid by **Thomas & Betts**. Factory will return repaired goods via same shipping method as received.

**FAILURE TO COMPLY WITH ANY OF THE STIPULATIONS SET FORTH WILL VOID THE WARRANTY. ANY EXCEPTIONS TO THE FOREGOING WARRANTY MUST BE REQUESTED AND ACCEPTED IN WRITING PRIOR TO SHIPMENT. HAZLUX EQUIPMENT NOT LISTED IN PARAGRAPHS 1.0–1.2 IS WARRANTED AS DESCRIBED ON ITS INDIVIDUAL DATA SHEET WITH THE STIPULATIONS AS STATED IN PARAGRAPHS 2.1-5.4.**

# Warranty

## Hazlux® DL, FDL, DFP LED, and XFM LED – series warranty

### **Warranty**

Thomas & Betts Coporation ("T&B") sells this product with the understanding that the purchaser will perform all necessary tests to determine the suitability for the user's intended application. Subject to the limitations set forth below, T&B warrants that the Hazlux LED fixture (the "product") will be free from defects in material and workmanship for a period of five (5) years beginning on the date of installation or 90 days from the date of shipment, whichever date is earlier (the "Warranty Period").

### **Warranty limitations and exclusions**

The above warranty shall only apply when the product is installed in applications in which ambient temperatures are within the range of specified operating temperatures and is operated within the electrical values shown on the LED driver label. This warranty is also void if the product has been subjected to misuse, neglect, accident, fire, physical damage, improper installation, unauthorized modification, or use in violation of our instructions or any applicable laws, codes, or ordinances.

# Visit the T&B world of electrical product solutions

Visit our web site for more information about Thomas & Betts solutions and our newest products. For a user-friendly catalog and competitive part number search, application and technical support and other useful information, go to: [www.tnb.com](http://www.tnb.com)

## Industry codes and specifications

All Thomas & Betts products meet or exceed applicable industry specifications or codes which are detailed in the appropriate T&B product literature.



IEEE ANSI IEC

## Online CAD library

Thomas & Betts offers free download of two- and three-dimensional CAD models of many of its products in more than 90 native CAD formats at: [www.tnb.com/cadlibrary](http://www.tnb.com/cadlibrary)

Please ask your Thomas & Betts sales representative for a complete catalog of quality Thomas & Betts electrical products or visit us at [www.tnb.com](http://www.tnb.com). For customer service, call 1-800-816-7809. For technical questions, call 1-888-862-3289.

© 2016 Thomas & Betts Corporation. All rights reserved. Printed in the U.S.A.  
12/16 CAT43

Thomas & Betts Corporation  
Electrification Products  
Division of ABB  
8155 T&B Boulevard  
Memphis, TN 38125  
901-252-5000  
[www.tnb.com](http://www.tnb.com)

**Thomas & Betts**  
A Member of the ABB Group