

CERT. N° 9105 BNVD



UNI EN ISO 9001: 2000



USE AND MAINTENANCE MANUAL

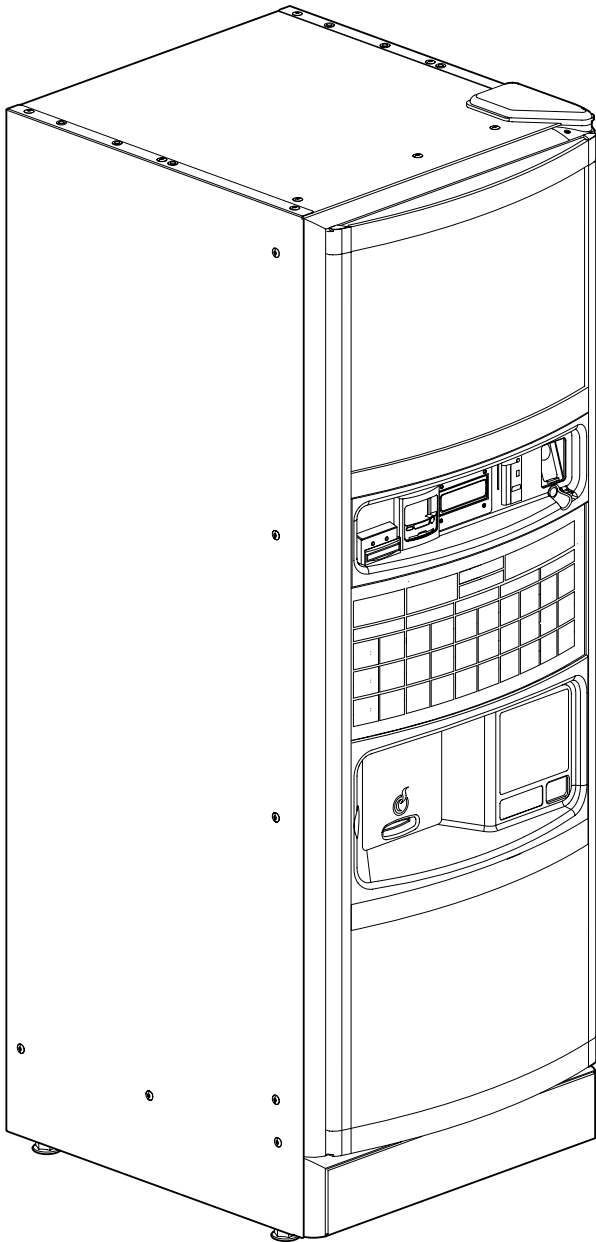

LEI 700

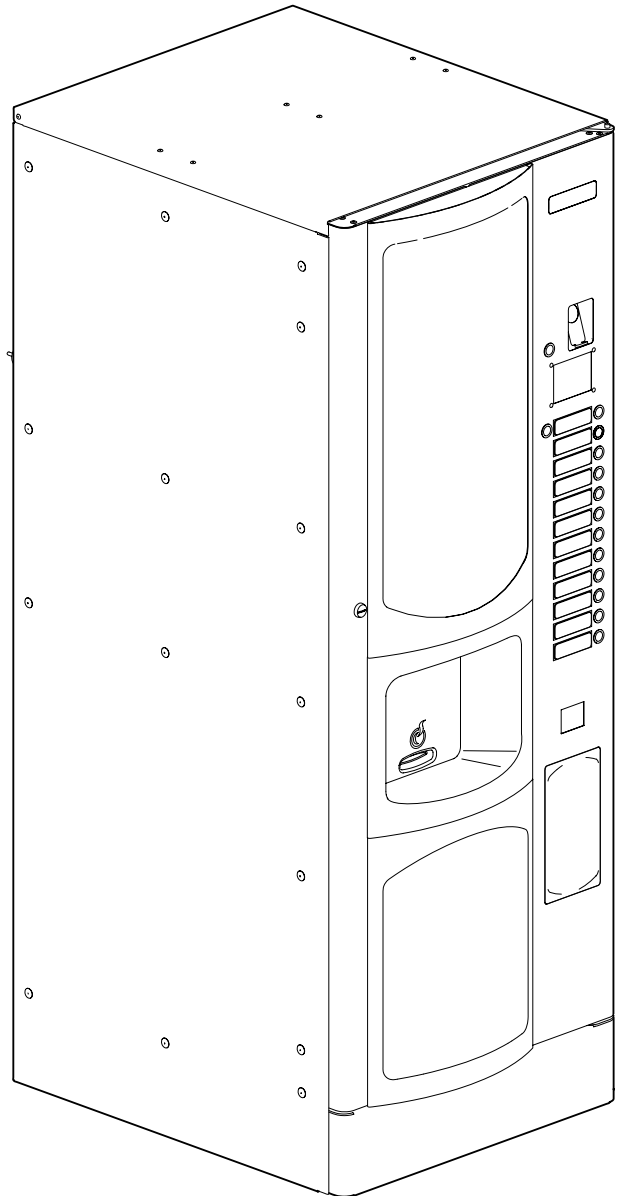

LEI 400

DECLARATION OF CONFORMITY

La **BIANCHI VENDING GROUP S.p.A.**
Corso Africa, 9 - 24040 Zingonia di VERDELLINO (BG) Italia

hereby declares under its own liability that the family of automatic vending machines - model:

LEI 700 - LEI 400

is complying with the safety measures foreseen by the directives:

1. **Low Voltage Directive** EEC 73/23 ⇒ EEC 93/68 ⇒ EEC2006/95 - LV -
2. **Electromagnetic compatibility** EEC 89/336 ⇒ EEC 91/263 ⇒ EEC 92/31 ⇒
93/68 ⇒ EEC 2004/108 -EMC-
3. **MATERIALS AND ARTICLES IN CONTACT WITH FOOD**
(1) REG. (EC) 1935/2004 on materials and articles intended to come into contact with food
(2) REG. (EC) 1895/2005 on the restriction of use of certain epoxy derivatives in materials and
articles intended to come into contact with food
(3) DIR. 2002/72 EC relating to plastic materials and articles intended to come into contact
with foodstuffs

The tests have been made in accordance with the Harmonized European Standards

1) **LOW VOLTAGE (Electrical safety LV):**

EN 60335-1 : 2002 + A1+ A11 (Safety of Household and Similar Electrical Appliances)
EN 60335-2-75: 2004+ A1 (Safety for Vending and dispensing Machines)
EN ISO 11201 + EN ISO 3744 Measurement of acoustic noise
Sound Pressure Level: LpA < 70 dB(A)

2) **ELECTROMAGNETIC COMPATIBILITY (EMC)**

EN 55014-1:2000+A1+A2
EN 55014-2:1997+A1
EN 61000-3-2: 2000+A2
EN 61000-3-3:1995+A1+A2

EN 61000-4-4
EN 61000-4-5
EN 61000-4-6
EN 61000-4-11
EN 61000-4-2

EN 50366:2003 +A1 Measurement of Electromagnetic field

3) **MATERIALS AND ARTICLES IN CONTACT WITH FOOD**

D.M. 21-03-1973 and its amendements ⇒ D.M. 2006 May 4th nr. 227, and receiptment of European Directives:82/711/EEC, 85/572/EEC, 93/8/EEC, 97/48/EC, 2002/72/EC, 2004/13/EC, 2004/19/EC, 2005/79/EC, Reg. EC n. 1935/04 e Reg.EC n. 1895/2005.

Zingonia di Verdellino (BG), January 2009

MANAGING DIRECTOR

Omero De Martin

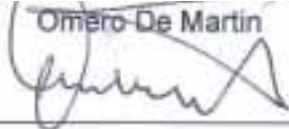

INFORMATION TO THE USERS

Under Legislative Decree 25 September 2007, no.185 and art. 13, Legislative Decree 25 July 2005, no.151 "Implementation of Directives **2002/95/EC**, **2002/96/EC** and **2003/108/EC**, regarding the reduction of use of hazardous substances in electrical and electronic equipment as well as waste disposal".



The barred waste container symbol on the equipment means that the product, at the end of its service life, must be disposed of separately from the other types of waste.

The user must therefore convey the equipment, at the end of its service life, to the appropriate separate collection centres for electronic/electrotechnical waste products or return it to the dealer when purchasing a new equivalent equipment.

The appropriate separate collection and the following sending of the used equipment to recycling, treatment and eco-friendly disposal will help avoid negative effects on the environment as well as on health along with an easier recycling of the materials forming the equipment.

Any unauthorized disposal of the product by the user will imply the enforcement of the administrative sanctions as set out in Legislative Decree no. 22/1997 (article 50 and following articles, Legislative Decree no. 22/1997).

Bianchi Vending Group S.p.A.

Società Unipersonale - Cap. Soc. € 5.000.000,00 i.v.
www.bianchindustry.com info@bianchindustry.com
P.I./C.F./Reg.Impr.BG 01945980223 IT - n° iscrizione R.A.E.E. IT08020000001049



Sede Legale - C.so Africa 9, 24040 Loc. Zingonia, Verdellino, BG, Italia, tel. +39.035.45.02.111, fax +39.035.883.304
Stab. Bergamo - Viale Parigi 5, 24040 Loc. Zingonia, Verdellino, BG, Italia, tel. +39.035.45.02.111, fax +39.035.883.304
Stab. Latina - Via Civitona 6/8, 04010 Loc. Le Castella, Cisterna di Latina, LT, Italia, tel. +39.035.45.02.111, fax +39.06.968.91.107
Stab. Pescara - Via Piano di Sacco 52, 65013 Contrada S. Agnese, Città S. Angelo, PE, Italia, tel. +39.035.45.02.111, fax +39.085.969.177

Declaration of Conformity

RoHS Directive

DIRECTIVE 2002/95/EC OF THE
EUROPEAN PARLIAMENT AND OF THE COUNCIL of 27 January 2003
on the restriction of the use of certain hazardous
substances in electrical and electronic equipment

Bianchi Vending Group S.p.A. declares:

Starting from July 1st 2006 any product manufactured by "Bianchi Vending Group Spa" on the European market is RoHS Directive compliant and do not contain concentrations exceeding limits allowed for the following substances:

- Lead (Pb)
- Mercury (Hg)
- Cadmium (Cd)
- Hexavalent Chromium (Cr(VI))
- Polybrominated Biphenyls (PBB)
- Polybrominated Diphenyl ethers:
 - o Polybrominated diphenyl ethers (PBDE)
 - o Octabromodiphenyl ether (OctaBDE)
 - o Decabromodiphenyl ether (DecaBDE)
- Perfluorooctane sulfonate (PFOS)
- PolyChloro Naphthalenes (PCN)
- Bis(tribromophenoxy)ethane Polychlorinated biphenyl (PCB)
- Benzene

CHIEF EXECUTIVE OFFICER

A handwritten signature in blue ink, written over a horizontal line.

Zingonia di Verdellino (BG), 12 January 2009

BEFORE USING THE MACHINE, READ THIS MANUAL CAREFULLY FOR ITS CORRECT USE IN ACCORDANCE WITH THE CURRENT SAFETY STANDARDS.



ATTENTION: Important safety indications



READ the instruction manual machine carefully before using the machine



For any service or maintenance **switch off** the machine

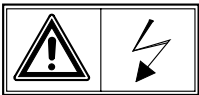

ATTENTION: machine switched on



ATTENTION: hot parts in contact!

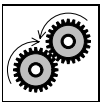

CAUTION! Parts in motion



Earthing indication



IMPORTANT NOTICES

MAINTENANCE TECHNICIAN



The maintenance technician is defined as being the person responsible for filling up the containers with soluble products, sugar, coffee, stirrers and cups.

The maintenance technician is also responsible for cleaning the distributor (see operations indicated in chapter 6.0). In the event of a fault the maintenance technician must call the installation technician.







INSTALLATION TECHNICIAN

The installation technician is defined as the person responsible for the installation of the automatic distributor, the starting up operations and the function settings.

Each regulation operation is the exclusive responsibility of the installation technician who also holds the programming access password.

Here below are the **STANDARD** configurations of the selection labels to insert into the keyboard of the indicated machine.

Selections keypad LEI700

		P1  SUGAR PUSH BEFORE 	P2 	P3 	A 1 2 3 4 5 B 6 7 8 9 0				
		P4  EXTRA MILK							
ESPRESSO 1		ESPRESSO 2		DEKA		BARLEY		INSTANT DRINKS	
P7 SHORT COFFEE	P8 LONG COFFEE	P13 SHORT COFFEE	P14 LONG COFFEE	P19 SHORT COFFEE	P20 LONG COFFEE	P25 SHORT COFFEE	P26 LONG COFFEE	P31 THE	P32 CHOCOLATE
P9 WHITE COFFEE	P10 CAPPUCCINO	P15 WHITE COFFEE	P16 CAPPUCCINO	P21 WHITE COFFEE	P22 CAPPUCCINO	P27 WHITE COFFEE	P28 CAPPUCCINO	P33 MILK	P34 MILK & CHOCOLATE
P11 CAPPCHOCC	P12 MILK AND COFFEE	P17 CAPPCHOCC	P18 MILK AND COFFEE	P23 CAPPCHOCC	P24 MILK AND COFFEE	P29 CAPPCHOCC	P30 MILK AND COFFEE	P35 HOT WATER	P36 ONLY CUP

Selections keypad LEI400

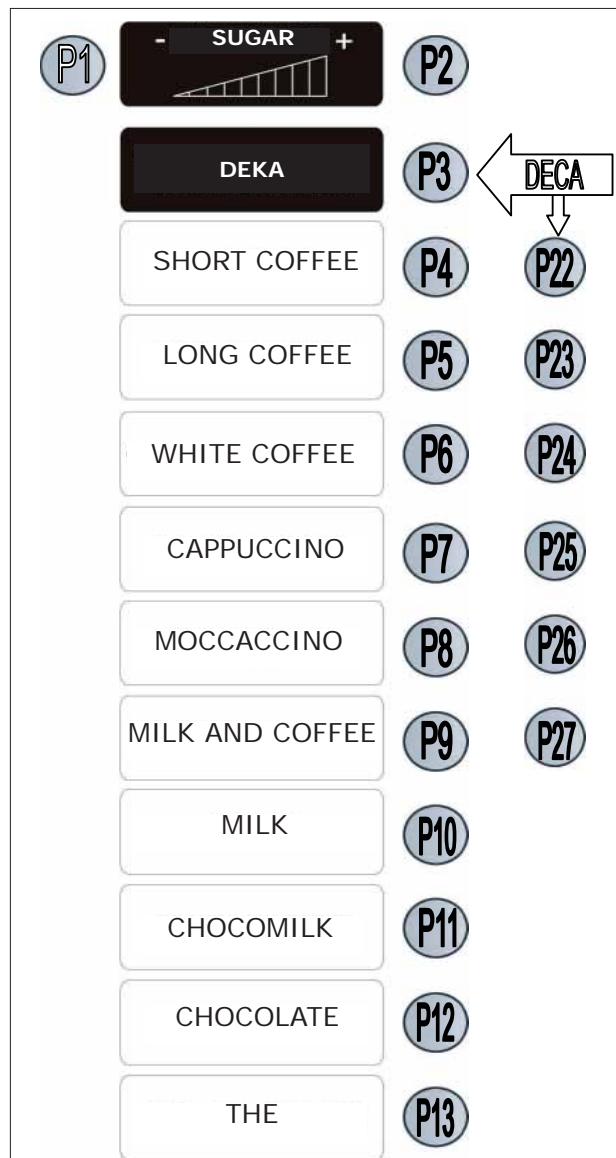

INDEX

PREMISE

- I Important notices for operator
- II Important notices
- III Safety rules

1.0 DESCRIPTION OF THE MACHINE'S TECHNICAL CHARACTERISTICS

- 1.1 Scheduled Use
- 1.2 Knowing the distributor

2.0 TECHNICAL DESCRIPTION OF THE OPERATION

- 2.1 Basic principle of operation
 - 2.1.1 Cup dispensing
 - 2.1.2 Sugar dispenser

3.0 TRANSPORTING THE AUTOMATIC VENDING MACHINE

- 3.1 Moving and Transport
- 3.2 Stocking
- 3.3 Packing
- 3.4 Reception
- 3.5 Unpacking

4.0 INSTALLATION

- 4.1 Positioning
- 4.2 Water supply connection
- 4.3 Power supply connection
- 4.4 Machine starting up
- 4.5 Installation
 - 4.5.1 Decalcificator resin washing where it is installed as accessory
 - 4.5.2 Filling of water circuit
 - 4.5.3 Cleaning of parts in contact with food substances
 - 4.5.4 Payment system installation
- 4.6 Product loading
 - 4.6.1 Product container loading
 - 4.6.2 Cup loading
 - 4.6.3 Spoon loading
 - 4.6.4 Spent coffee grounds bag insertion
- 4.7 Automatic distributor layout
- 4.8 First self installation mode

5.0 SOFTWARE INSTRUCTIONS

- 5.1 Password
- 5.2 Machine and winbianchi menus
- 5.3 Complete programming menu
- 5.4 Maintenance

6.0 MAINTENANCE AND INACTIVITY

- 6.1 Cleaning and loading procedures
 - 6.1.1 Recommended maintenance
 - 6.1.2 Periodic cleaning by the maintenance technician
 - 6.1.3 Daily cleaning procedures
 - 6.1.4 Product Loading instructions
- 6.2 Ordinary and Extraordinary Maintenance
- 6.3 Maintenance procedures
 - 6.3.1 Sanitization
- 6.4 Regulations
 - 6.4.1 Dosage and grinding regulation
 - 6.4.2 Instant electrovalve water flow regulation
 - 6.4.3 Access to internal parts
- 6.5 BRITA decalcificator filter
- 6.6 Resing regeneration (optional)
- 6.7 Inactivity

7.0 DISMANTLEMENT

8.0 ALARMS

- 8.1 Alarms
 - 8.1.1 Displayed blocking alarms
 - 8.1.2 Alarms displayed under maintenance



Keys at the disposal of the MAINTENANCE and INSTALLATION technicians

N° 1 Chiave
 N° 1 Key
 N° 1 Clé
 N° 1 Schlüssel
 N° 1 Llave
 N° 1 Chave

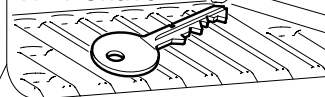

Tools necessary for undertaking interventions on the automatic dispenser.

SOCKET SPANNERS

n° 5,5
 n° 7
 n° 8
 n° 10
 n° 20
 n° 22

SPANNERS (fork type)

n° 7
 n° 8
 n° 10
 n° 12
 n° 14

SCREWDRIERS

Small size
 Medium size
 Large size

Normal cross
 Small cross
 Medium cross
 Large cross
 Of Teflon, small size for Trimmer regulation.

RATCHET SPANNER no.14

TESTER

ELECTRICIAN'S SCISSORS

PROGRAMMING KIT



PREMISE

I - Important notices for operator

This automatic distributor has been designed and constructed in full accordance with current safety regulations and is therefore safe for those who follow the ordinary filling and cleaning instructions as indicated in this manual.

 *The user must not under any circumstances remove the guards that require a tool for removal.*

Some maintenance operations (to be done solely by specialized technicians and indicated in this manual with a special symbol) require that specific safety protections of the machine must be switched off.

In accordance with the current safety regulations, certain operations are the exclusive responsibility of the installation technician, and the ordinary maintenance technician may have access to specific operations on with specific authorization.

The acquaintance and absolute respect, from a technical point of view, of the safety instructions and of the danger notices contained in this manual, are fundamental for the execution, in conditions of minimum risk, for the installation, use and maintenance of this machine.

II - General Instructions

 *Knowledge of the information and instructions contained in the present manual is essential for a correct use of the automatic vending machine on the part of the user.*

– *Interventions by the user on the automatic vending machine are allowed only if they are of his competence and if he has been duly trained.*

The installation technician must be fully acquainted with all the mechanisms necessary for the correct operation of the machine.

– *It is the buyer's responsibility to ascertain that the users have been trained and are informed and regulations indicated in the technical documentation supplied.*

Despite the full observance of the safety regulations by the constructor, those who operate on the automatic dispensers must be fully aware of the potential risks involved in operations on the machine.

– *This manual is an integral part of the equipment and as such must always remain inside of the same, so as to allow further consultations on the part of the various operators, until the dismantlement and/or scrapping of the machine.*

– *In case of loss or damage of the present manual it is possible receive a new copy making application to the manufacturer, with prior indication of the data registered on machines' serial number.*

– *The functional reliability and optimization of machine's services are guaranteed only if original parts are used.*

– *Modifications to the machine not previously agreed on with the construction company and undertaken by the installation technician and/or manager, are considered to be under his entire responsibility.*

All the operations necessary to maintain the machine's efficiency, before and during it's use are at the users charge.

– *Any manipulations or modifications made to the machine that are not previously authorized by the manufacturer, relieve the latter from any responsibility for damages deriving from, and will automatically result in the cancellation of the machine guarantee terms.*

– *This manual reflects the status at the moment of the emission of the automatic vending machine on the market; possible modifications, upgrading, adaptmets that are done the machine and that are subsequently commercialized do not oblige **BIANCHI VENDING GROUP Spa** neither to intervene on the machine previously supplied, nor, neither to update the relative technical documentation supplied together with the machine.*

– *It is however **BIANCHI VENDING's Group** faculty, when deemed opportune and for valid motives, to adjourn the manuals already present on the market, sending to their customers adjournment sheets that must be kept in the original manual.*

Possible technical problems that could occur are easily resolvable consulting this manual ; For further information, contact the distributor from whom the machine has been purchased, or contact Bianchi Vending's Technical Service at the following numbers:

 **+039. 035.45.02.111**
fax +039. 035.883.304

When calling it is advisable to be able to give the following information:

- *The data registered on the serial number label (Fig.1)*
- *version of program contained in the microprocessor (Adhesive label on the component installed on board).*

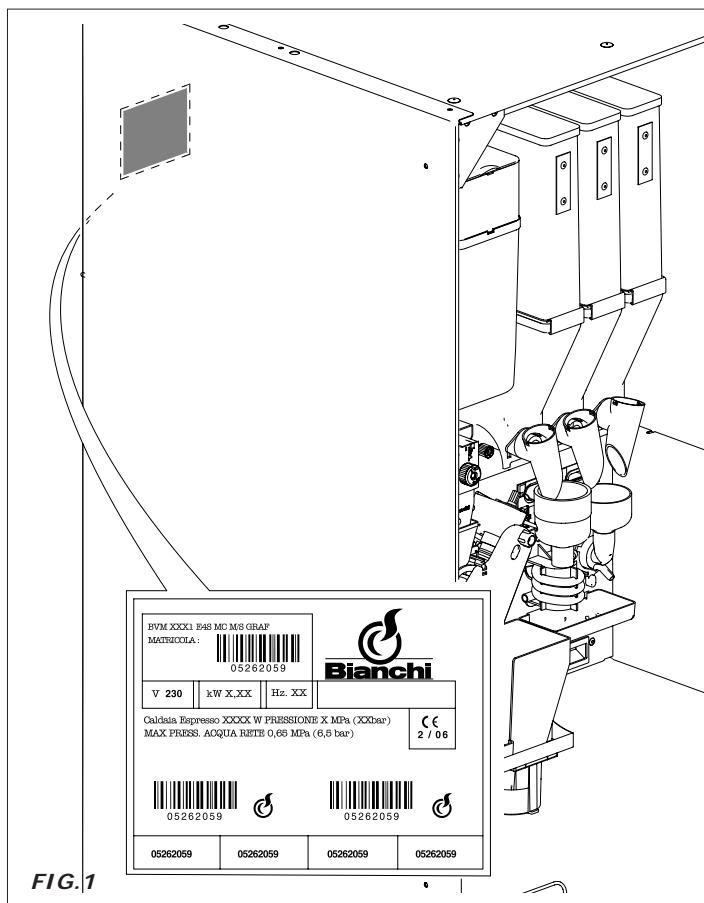

FIG.1

BIANCHI VENDING GROUP Spa declines any responsibility for damages caused to people or belongings in consequence to:

Incorrect installation

Inappropriate electrical and/or water connection.

Inadequate cleaning and maintenance

Not authorized modifications

Improper use of the distributor

Not original spare parts

- Under no circumstances is **Bianchi Vending Group Spa** obliged to compensate for eventual damage resulting from the forced suspension of drink deliveries as the result of faults.
 - Installation and maintenance operations, must be done exclusively by qualified technical personnel with prior training for carrying out these duties.
 - For refilling use only food products that are specific for automatic vending machines.
 - The automatic distributor is not suitable for external installation. The machine must be installed in dry places, with temperatures that never go below 1°C it must not be installed in places where cleaning is done with water hoses (ex. big kitchens.).
- Do not use water jets to clean the machine.*

III - SAFETY NORMS

ATTENTION!



– before using the automatic distributor, read this manual carefully.

- The installation and maintenance operations must be performed exclusively by qualified technical personnel.
- The user must not in any circumstance be able to access those parts of the automatic distributor that are protected and require a tool in order to be accessible.
- The knowledge and the absolute respect, from a technical point of view of the safety instructions and of the danger notices contained in this manual, constitute the basis for the operation, in conditions of minimum risk, of the installation, starting and maintenance of the machine.



Always disconnect the POWER CABLE before maintenance or cleaning interventions.



ABSOLUTELY DO NOT INTERVENE ON THE MACHINE AND DO NOT REMOVE ANY PROTECTION BEFORE THE COOLING OF THE HOT PARTS!

- The functional reliability and optimization of machine's services are guaranteed only if original parts are used.
- In order to guarantee normal operation, the machine must be installed in areas that the environmental temperature is between a minimum of +1°C and a maximum of +50°C and humidity of not over 85%.
- In order to guarantee a regular operation, always maintain the automatic distributor in perfect cleaning conditions
- If at the moment of the installation, if conditions differing from those indicated in the present manual, or should the same undergo changes in time, the manufacturer must be immediately contacted before use of the machine.
- Also check that any other eventual norms or regulations as laid down by national or local legislation are taken into account and applied.

This device is not intended for use by individuals (including children) with reduced physical, sensorial or mental capacities, or by individuals without the required knowledge and experience, unless said individuals have been instructed on the use of the device and are duly supervised by a person responsible for their safety. Children must be monitored to ensure that they do not play with the device, or use it as though it were a toy.

Access to the service area is allowed only by personnel that have been specifically trained accordingly and that have acquired practical experience on the devices.

1.0 TECHNICAL CHARACTERISTICS

	Lei700	Lei400
Height (A) mm	1830	1630
Width (B) mm	666	650
Depth (C) mm	776	770
Weight	140 kg ÷ 190 kg ⁽³⁾	128
Power Supply	V230 - 50Hz / V120 - 60Hz	
Installed power ⁽¹⁾	1,8 kW ÷ 3,2 kW	1,8 kW ÷ 3,2 kW
Nominal current (Max)	8 A - 15 A	8 A - 15 A
Water supply	0,5 ÷ 6,5 bar	0,5 ÷ 6,5 bar
<i>AVERAGE CONSUMPTIONS:</i>		
IDLE STATE MODE according to EVA-EMP	110-220 Wh/h	110-220 Wh/h
ENERGY CONSUMPTION PER LITRE according to EVA-EMP	150-230 Wh/L	150-230 Wh/L
Water supply connection	3/8" gas	3/4" gas
Electrical supply connec.	Schuko plug	Schuko plug
<i>DISTRIBUTORE BICCHIERI</i>		
Diametro bicchieri	70÷74mm	70÷74mm
<i>RESISTENZA CALDAIA</i>		
of armoured type:	coffee boiler: 1500W	coffee boiler: 1500W
of armoured type:	instant boiler: 2000W	instant boiler: 2000W
<i>PRODUCT CONTAINER CAPACITY</i>		
Coffee in beans Double grinder	da 3,8 a 4,5 Kg Kg 3,5 cad. (x2)	Kg 2,5*
Instant coffee	Kg 1,4	Kg 1,0
Barley	Kg 1,4	Kg 1,25
Powder milk	Kg 2,2	Kg 1,70
Creamer	Kg 4,0	Kg 3,20
Chocolate	Kg 4,8	Kg 3,6
Tea	Kg 5,2	Kg 3,30
Frozen-dry tea	Kg 2,4	Kg 1,70
Broth	Kg 3,8	Kg 3,6
Sugar	Kg 5,2	Kg 4,0
Caps N°	700	400
Spoons N°	540	400
Type of light	LED	LED
A-weighted sound pressure level		
A-weighted sound power level		

* With assembly of the 3.8 kg extension kit.

⁽¹⁾ Check the rated output indicated on the data plate applied by the distributor.

⁽²⁾ According to the requested version and the applicable standards in the place of use.

⁽³⁾ According to the version.

1.1 Foreseen use

The automatic distributor is exclusively for the dispensing of drinks, prepared mixing food substances with water (by infusion as far as concerns espresso coffee).

For this purpose use products declared as suitable by the manufacturer for automatic distribution in open containers. The drinks are made in specific plastic cups automatically dispensed by the machine. Where foreseen, also the spoon for mixing the sugar is dispensed.

The drinks must be consumed immediately and in no case are to be kept for subsequent consumption.

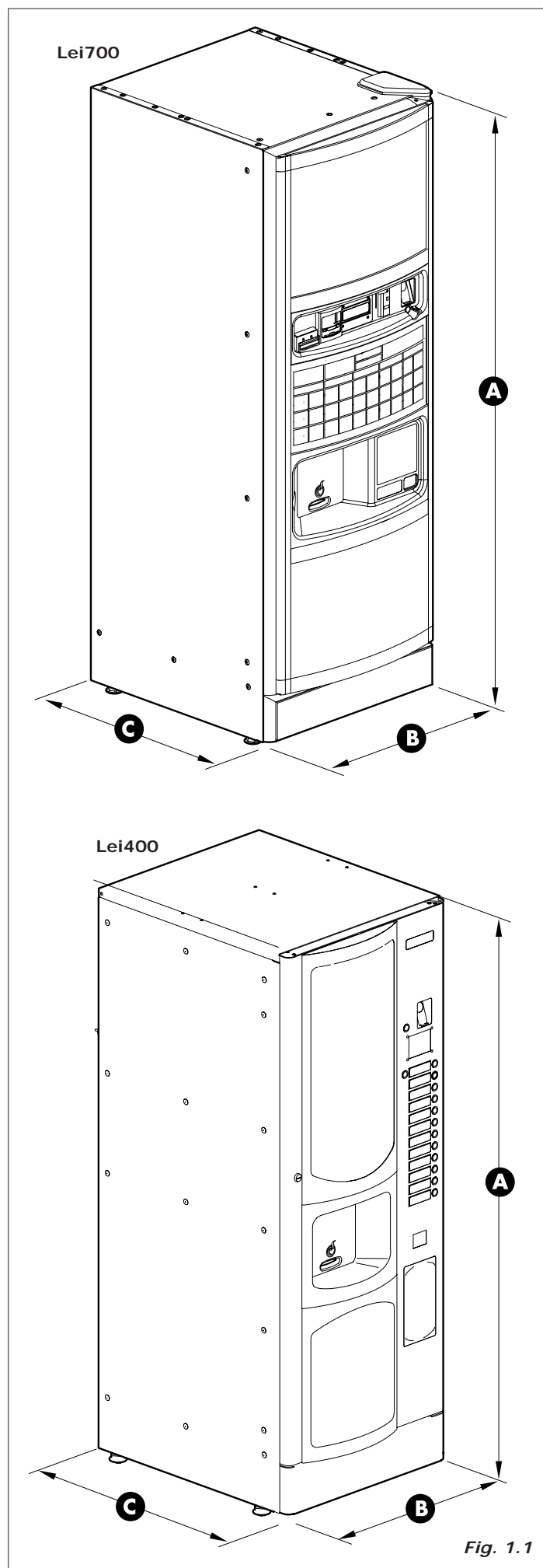

Fig. 1.1

1.2 KNOWING THE DISTRIBUTOR

Mod. Lei700 (Fig.1.2)

- 1 Coffee group and grinder
- 2 Drink dispensing group
- 3 Sugar dispenser group
- 4 Payment system
- 5 Cup column
- 6 Electronics board CPU
- 7 Power card
- 8 Spoons column
- 9 Water softener filter
- 10 Water bin
- 11 Dispensing chamber
- 12 Service button
- 13 Washing button

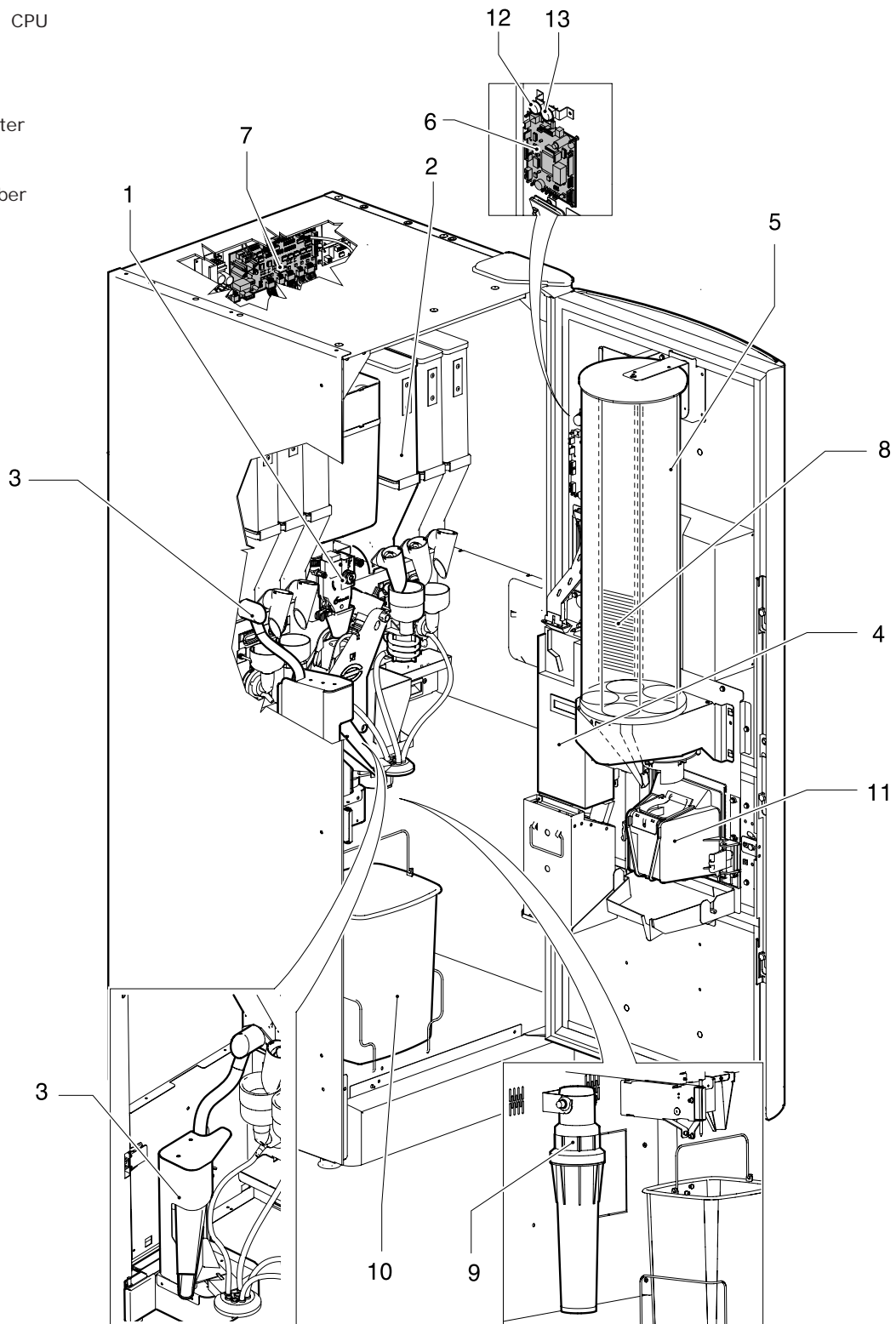

Fig. 1.2

Mod. Lei400 (Fig.1.3)

- 1 Coffee group and grinder
- 2 Drink dispensing group
- 3 Sugar dispenser group
- 4 Payment system
- 5 Cup column
- 6 Electronics board CPU
- 7 Power card
- 8 Spoons column
- 9 Water softener filter
- 10 Water bin
- 11 Dispensing chamber
- 12 Service button
- 13 Washing button
- 14 Upper case

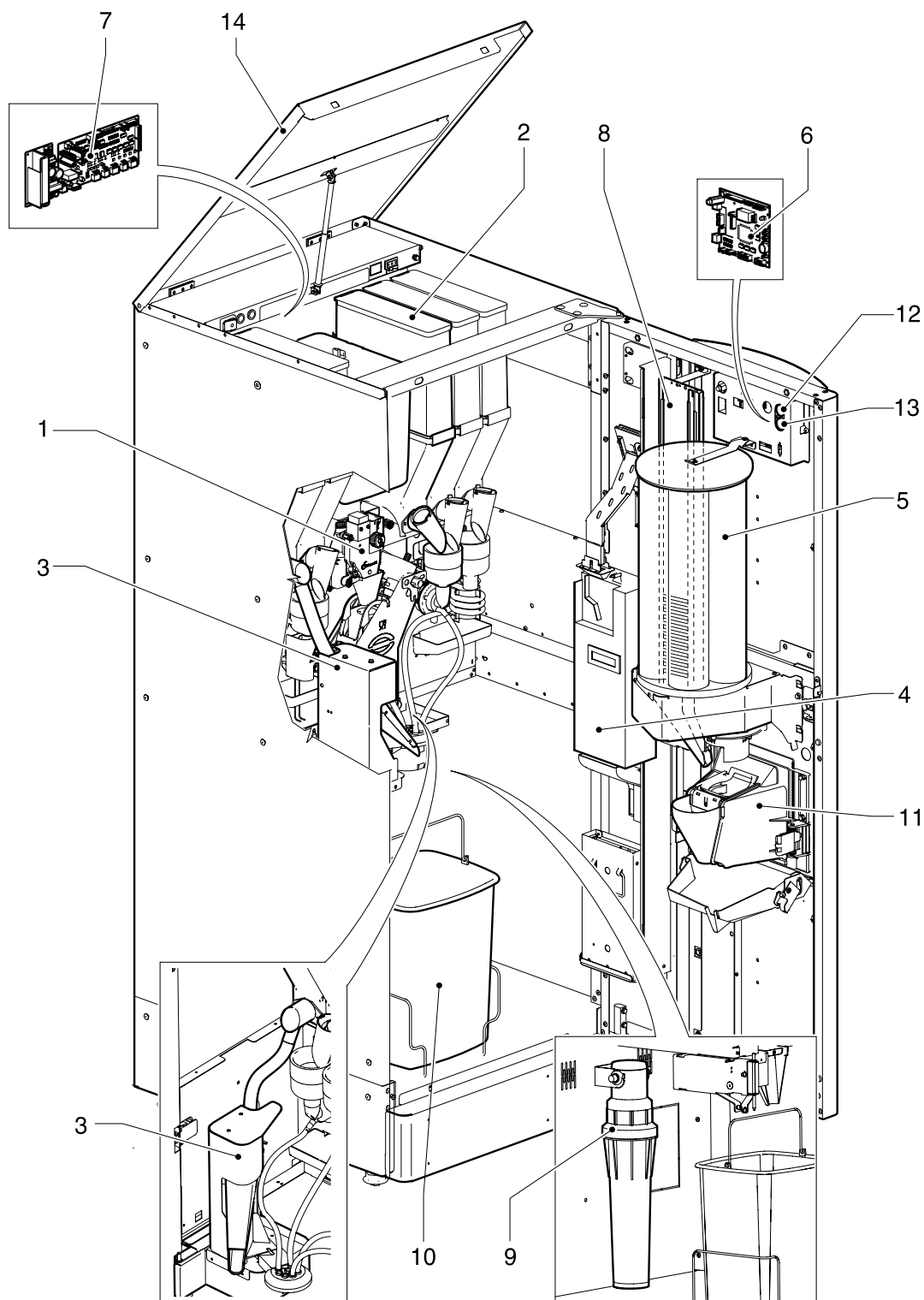

Fig. 1.3

2.0 TECHNICAL DESCRIPTION OF THE OPERATION

During the normal functioning the distributor is set in standby status.

Introducing the necessary amount, according to the set price, and after pressing the key relative to the desired drink, the drink dispensing cycle is activated and can be divided in to different processes:

2.1 BASIC PRINCIPLE OF OPERATION

2.1.1 CUP DISPENSING

- It is the first operation that the distributor starts (except for the selections with pre-selection "without CUP").
- the motor inside of the cup dispenser moves the plastic gear to separate and make the cup fall into the cup ring inside the cup dispenser (Fig.2.1).

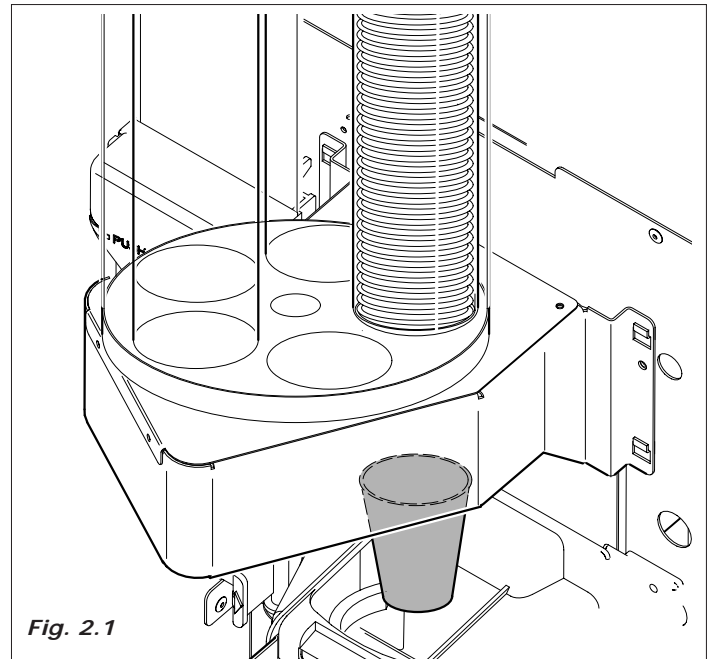

Fig. 2.1

2.1.2 SUGAR DISPENSER

The sugar is dispensed directly in the cup in the E versions whereas for the I versions it is pre-mixed with the instant drinks.

The display management of the presentation INC+ / DEC- Sugar, is represented this way:

Line 1: Sugar

Line 2: ■ ■ ■ ■ ■ ■ ■ ■ □

Each square is equivalent to x sec of sugar according to the following equation

$$\blacksquare = (A+B)/8$$

A = Quantity in seconds of sugar in the standard drink

B = Quantity in seconds of sugar in the preselection +

8 = Maximum number of squares

The dispensing procedure occurs according to the following phases:

- the geared motor activates the helicoidal screw conveyor of the sugar product container, dispensing the desired quantity into the product chutes (Fig.2.2)

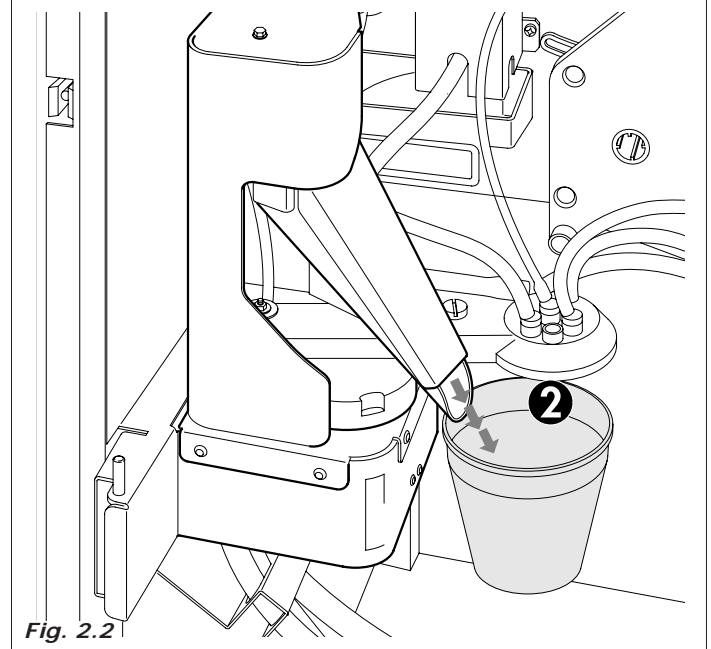
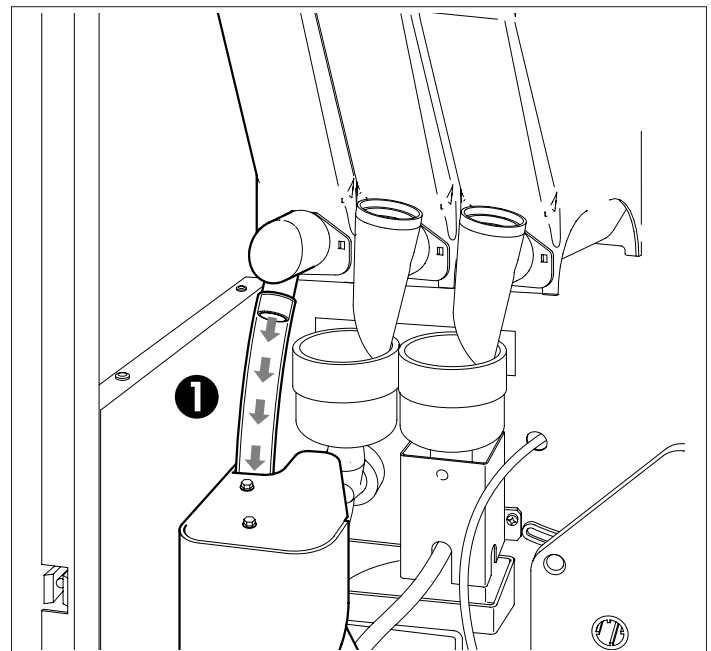

Fig. 2.2

ESPRESSO COFFEE

This process functions only the models equipped with the coffee espresso group (brass or plastic), after the cup and sugar dispensing processes have been effected.

- the grinder is activated until it reaches the dose of ground coffee set by the doser (Fig.2.3)
- the doser electromagnet is activated , causing the opening of the door and consequent fall of the coffee into the brew chamber
- the rotation group geared motor brings it into the dispensing position and simultaneously compresses the ground coffee (Fig.2.4 - Fig.2.5).
- the pump that dispenses the quantity of programmed water and that is controlled by a specific electronic device, (volume meter), extracting the water from the coffee boiler(Fig.2.6).
- the coffee group geared motor is activated again so as to bring again into standby position ; during this movement the used coffee grounds are expelled

The sequence of these operations (grinding and coffee dispensing) could occur in inverse order according to the type of programme used.

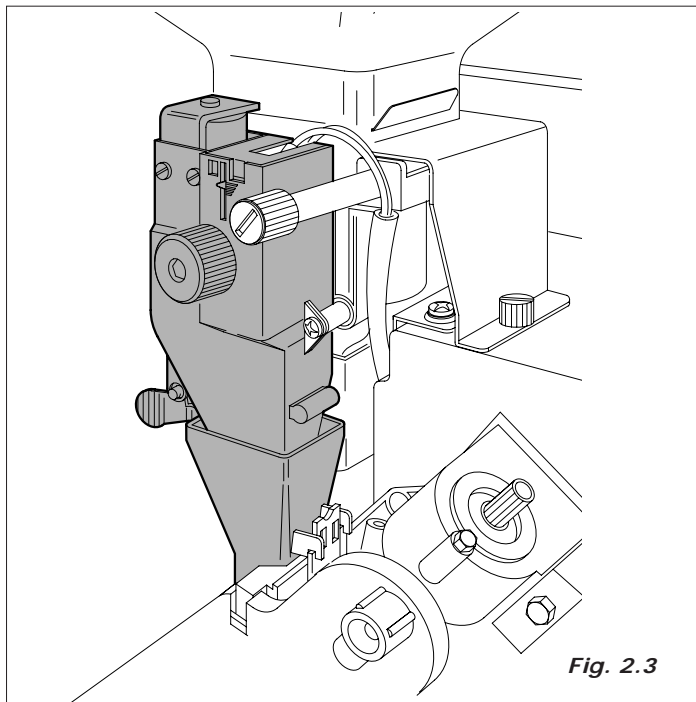

Fig. 2.3

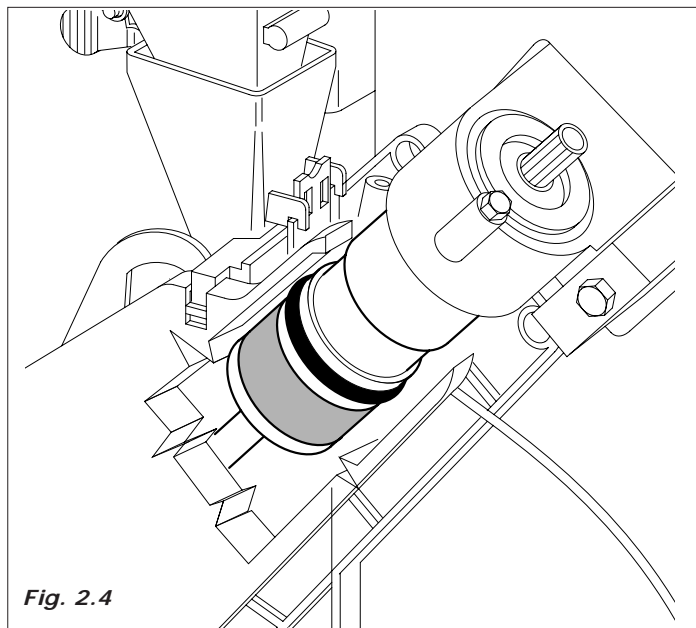

Fig. 2.4

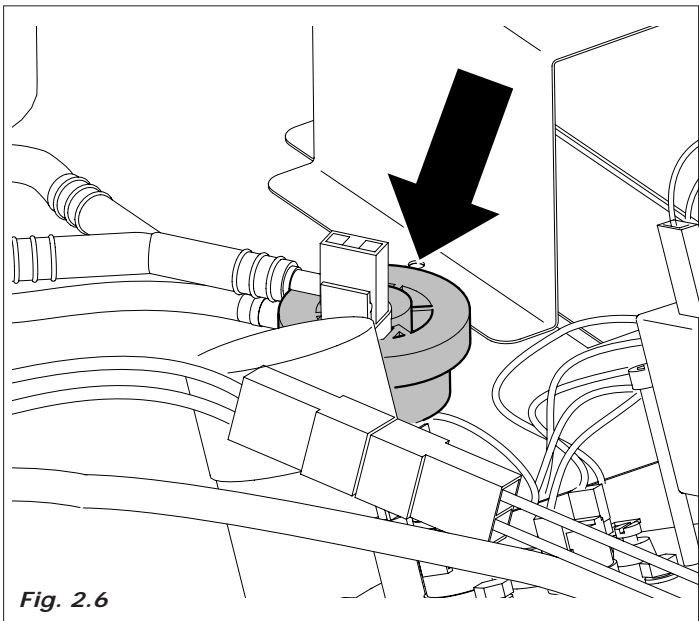

Fig. 2.6

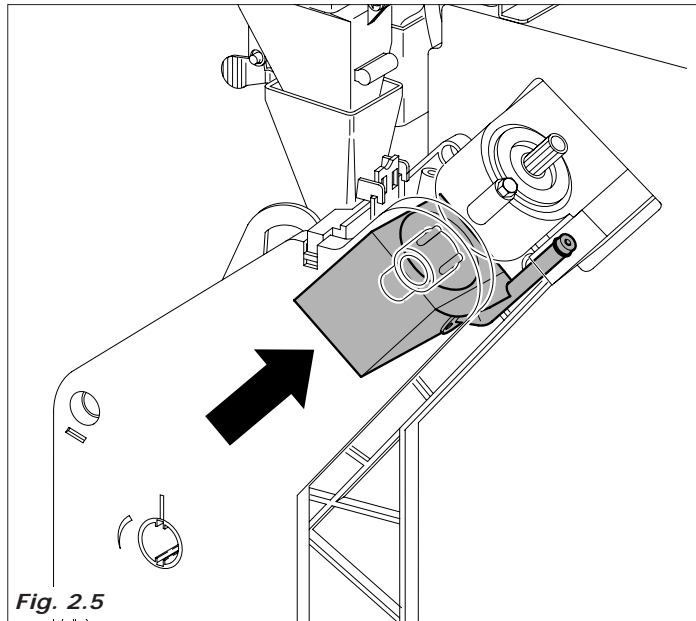

Fig. 2.5

SPOON DISPENSING

This process is activated only in the versions where the spoon dispenser is foreseen; In these versions it is possible to select the spoon in the selections without sugar and/ or in the instant selections.

- the geared motor that operates the spoon release device is activated making the spoon fall into the cup. (Fig.2.7).

INSTANT DRINKS

This process is activated when the cup and spoon dispensing processes have been completed.

According to the type drink requested and to the distributor model, several of the various processes described here below can be activated.

- If present, the whipper motor is activated (Fig.2.8)
- The electro valve fixed on the soup boiler (Fig.2.9) or on the coffee boiler (Fig.2.10). it is activated to introduce into the mixer the programmed water quantity.

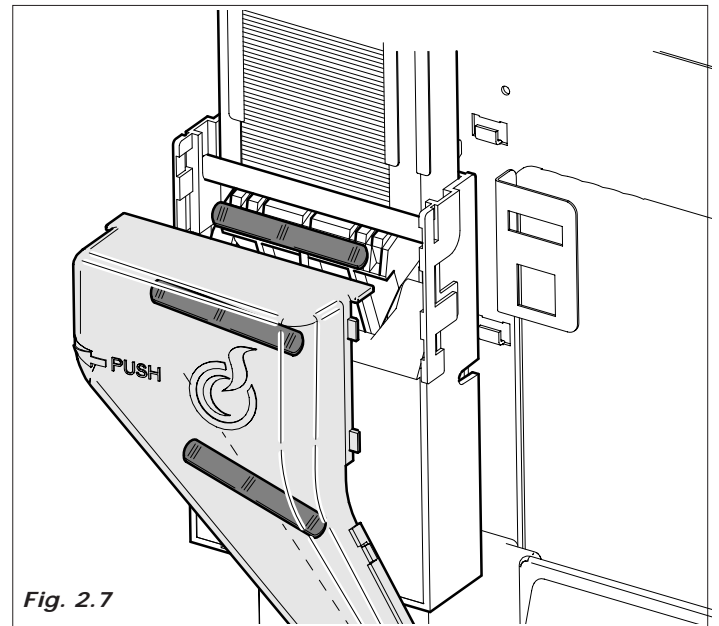

Fig. 2.7

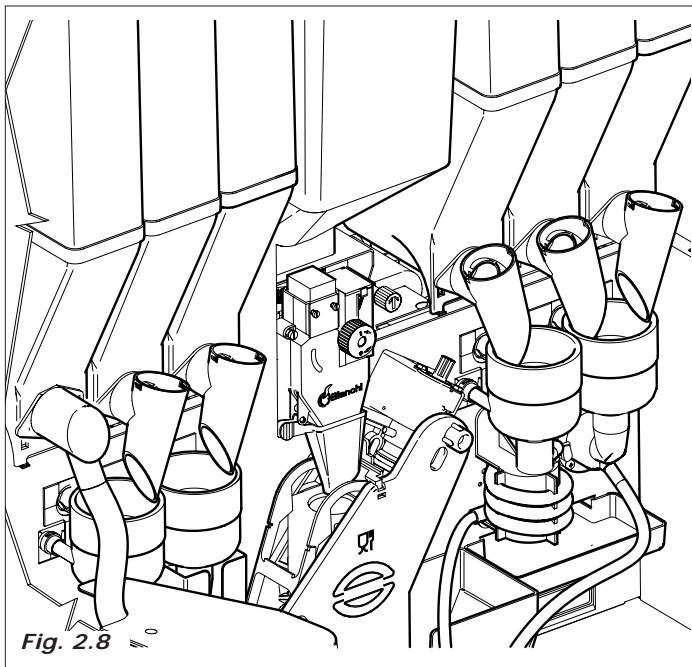

Fig. 2.8

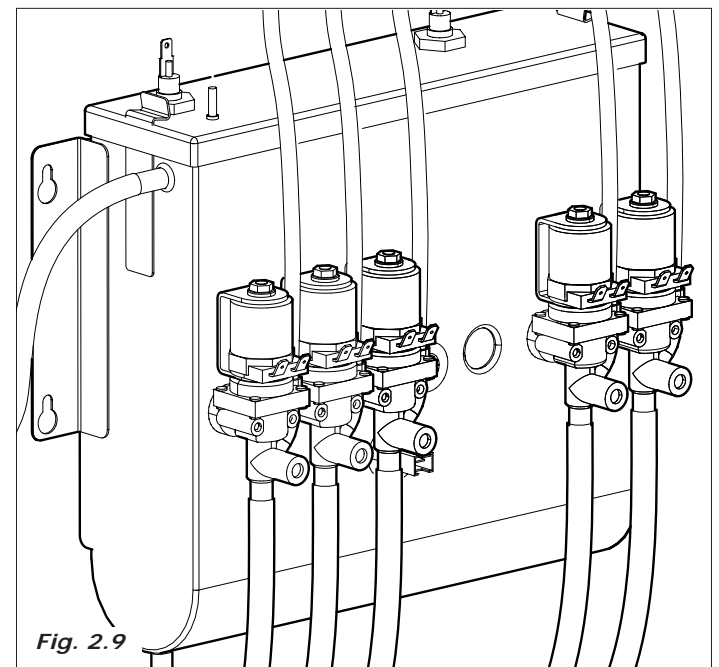

Fig. 2.9

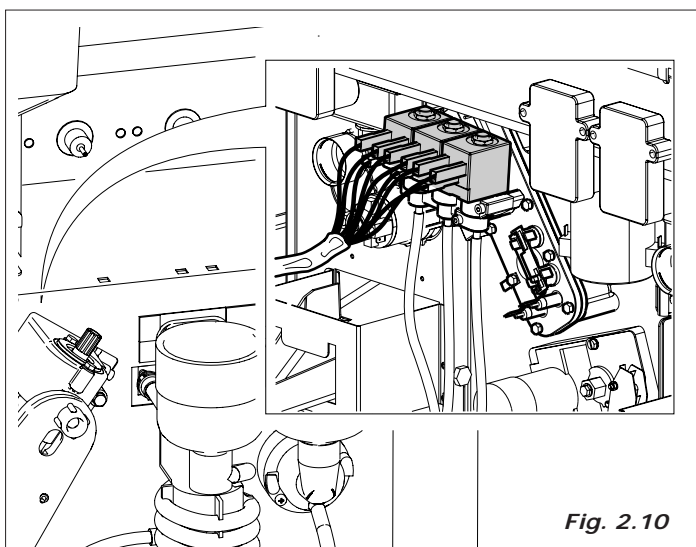

Fig. 2.10

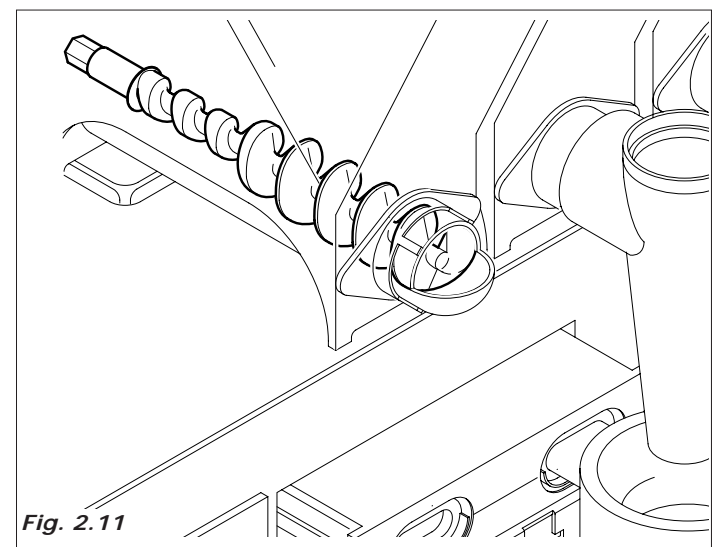

Fig. 2.11

- The instant product geared motor activates the helicoidal screw conveyor so as to dispense the quantity of product programmed into the mixer (in some versions several products can be processed in the same mixer such as milk and chocolate) (Fig.2.11)
- Once the preset water and powder quantity has been supplied, the mixer is disabled after a time (T) set during the programming.



3.0 MOVING AN AUTOMATIC VENDING MACHINE

3.1 Moving and transport (Fig.3.1)

The transport of the distributor must be effected by competent personnel.

The distributor is delivered on a pallet; for the shifting use a trolley and move it slowly in order to avoid capsizing or dangerous movements.



Avoid :

- lifting the distributor with ropes or presses
- dragging the distributor
- upset or lay down the distributor during transport
- give jolts to the distributor

Avoid as the distributor:

- bumping it
- overloading it with other packages
- exposing it to rain, to cold or sources of heat
- keeping it in damp places

The construction company is not liable for any damage which may be caused for the partial or complete non-observance of the warning notices indicated above.

3.2 Stocking

For eventual stocking, avoid laying several machines over each other, maintain it in vertical position, in dry places with temperatures not inferior to 1°C (Fig.3.2).

3.3 Packing

The distributor is protected with polystyrene angles and by a transparent film in polypropylene (Fig.3.2).

The automatic distributor will be delivered packed, assuring both a mechanical protection and protection against damages from the external environment.

On the package labels are applied indicating:

- maneuver with care
- don't turn upside-down
- protect from the rain
- don't superimpose
- protect from sources of heat
- not resistant against bumps
- type of distributor and serial number.

3.4 Reception

Upon reception of the automatic distributor you need to check that the same has not suffered damages during the transport.

If damages of any nature are noticed place a claim with the forwarder immediately.



At the end of the transport the packing must result without damages which means it must not :

- present dents, signs of bumps, deformations or damages of the external packaging
- present wet zones or signs that could lead to suppose that the packing has been exposed to rain, cold or heat.
- present signs of tampering

3.5 Unpacking

- Free the distributor from the packaging , cutting the protective film in which it is wrapped, along one of the protection angles (Fig.3.3).
- Remove the distributor from transport pallet, unscrewing the screws (A) that block the fixing cross staff heads to the pallet (Fig.3.4).

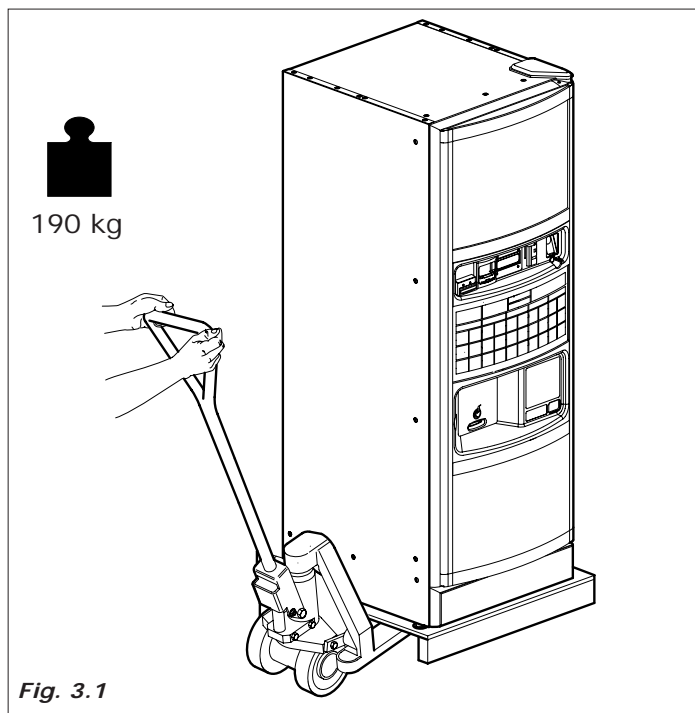

Fig. 3.1

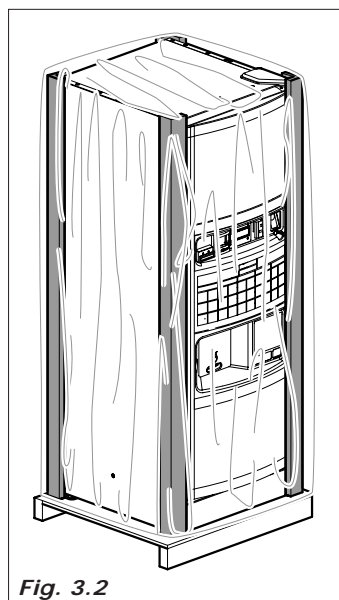

Fig. 3.2

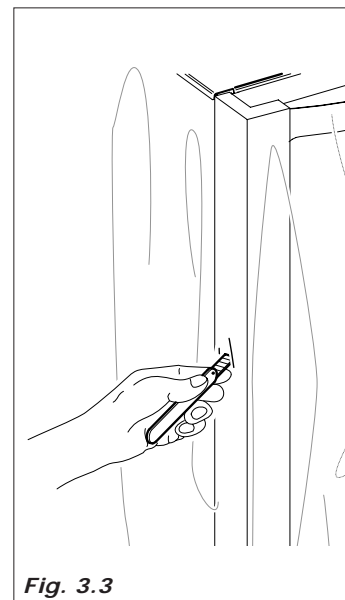

Fig. 3.3

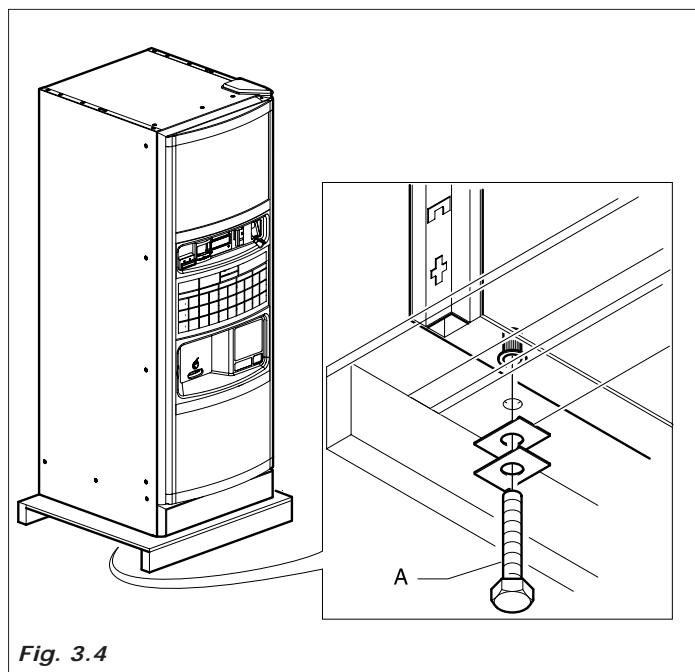



Fig. 3.4

- Release the pallet and insert the 4 feet into the threaded slots (fig. 3.5) freed of the screws (A)
- remove the key from the drink dispensing chamber (Fig.3.6)

Open the door of the distributor and remove the adhesive tape from the components listed here below:

- cup turret (example in Fig.3.7)
- coin box
- sugar container
- weight on the spoon dispenser column
- coin mechanism cover / Master board
- product containers
- water bin float mechanism
- bottom skirting-board
- water bin
- remove the polystyrene that that blocks the product containers (Fig.3.8)

 *The packing material must not be left accessible to others, as it is a potential environmental pollution sources. For the disposal contact qualified companies authorized.*

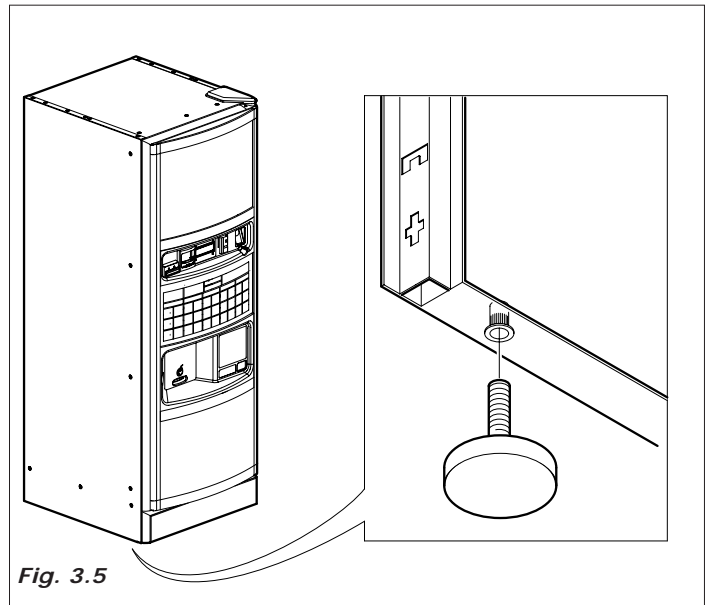

Fig. 3.5

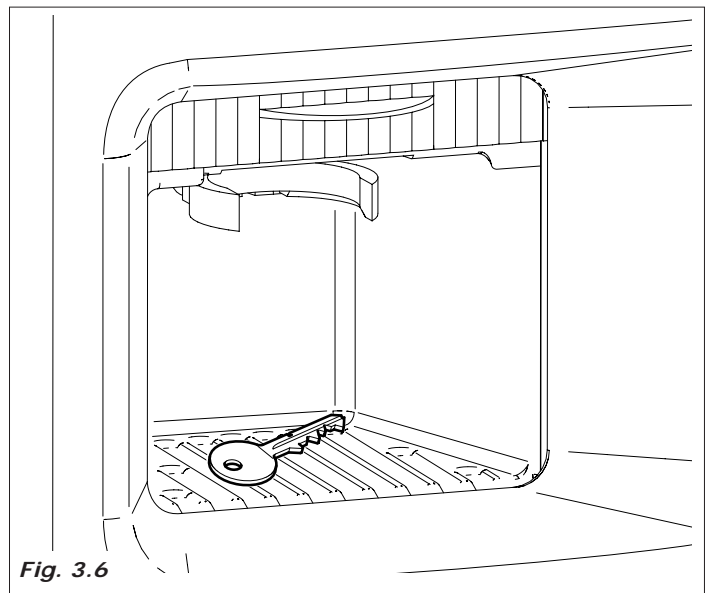

Fig. 3.6

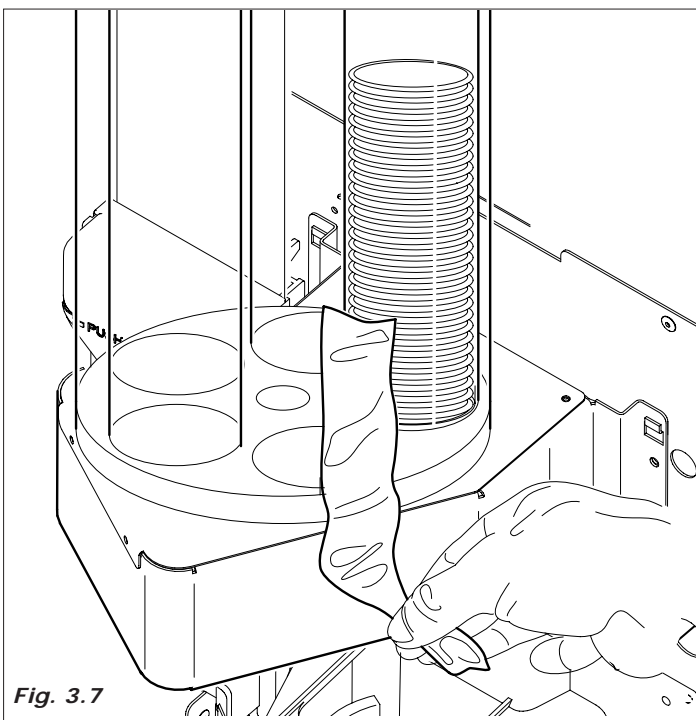

Fig. 3.7

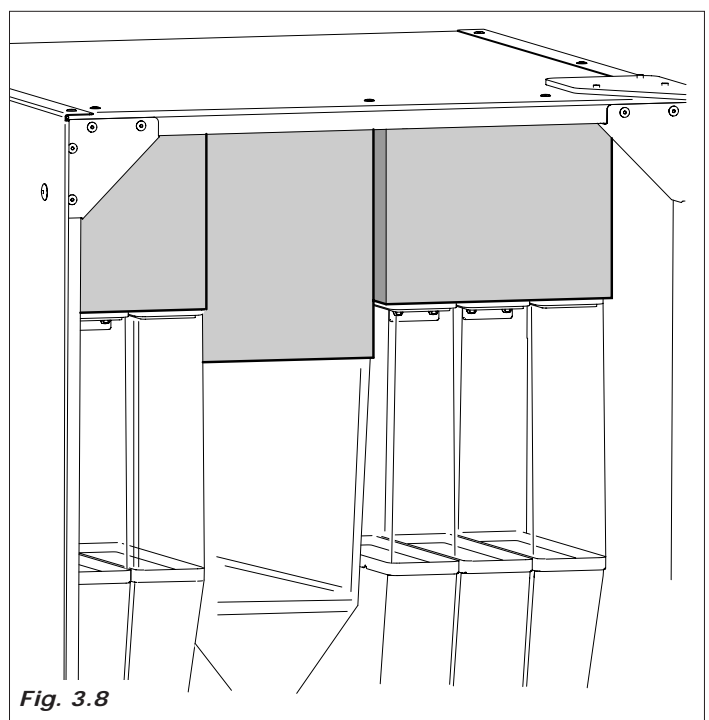

Fig. 3.8

4.0 INSTALLATION



4.1 Positioning

- If positioned near to a wall, there must be a minimum distance from the wall of at least 5 cm. (Fig.4.1) so as to allow a regular ventilation. In no case cover the distributor with cloths or similar.
- For safety reasons we recommend use of the lock-on brackets (Fig. 4.2)
- Position the distributor, checking the leveling by means of the adjustable feet already assembled on the machines (Fig.4.3). make sure that the distributor doesn't have an inclination of more than 2 degrees.



WARNING! Do not position the device near inflammable objects, keep a minimum safety distance of 30 cm.

Bianchi Vending Group spa declines all responsibility for inconveniences due to the non observance of the above mentioned installation norms.

If the installation is made in safety evacuation corridors make sure that with the distributor door open there is anyhow sufficient space to pass by (Fig.4.1).

So as to avoid that the floor gets dirty, due to accidental spilling of the products, use, if necessary, under the distributor, a protection sufficiently wide to cover the distributors' operating space.

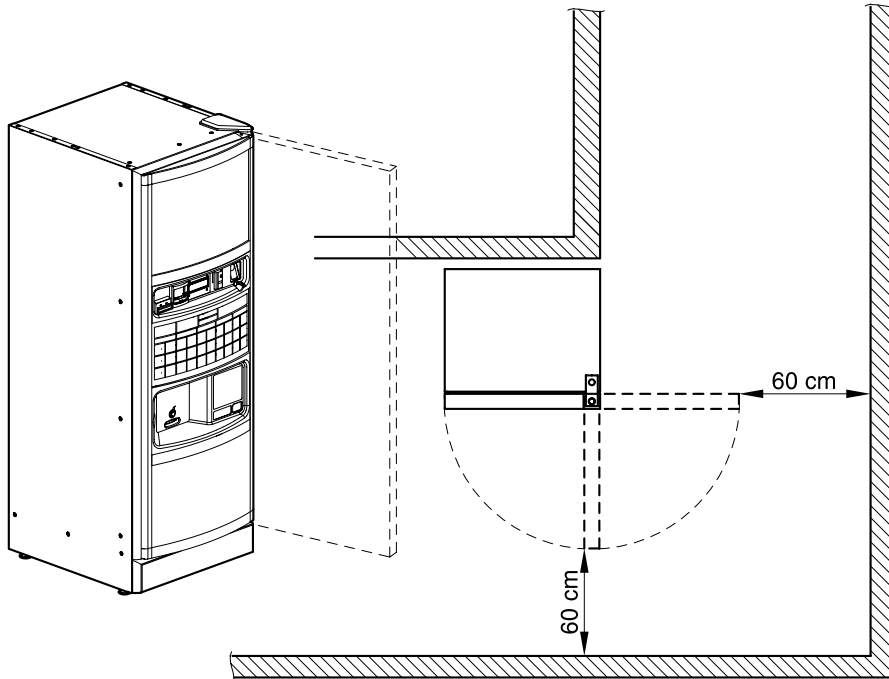

Fig. 4.1

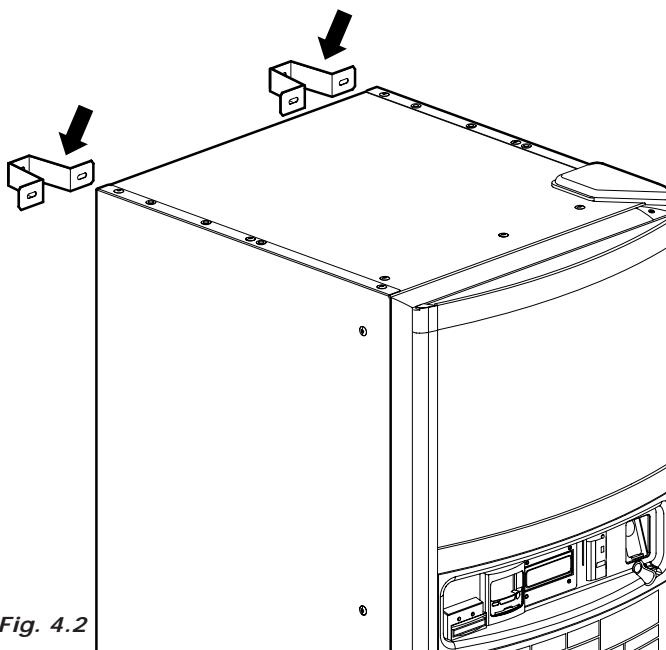

Fig. 4.2

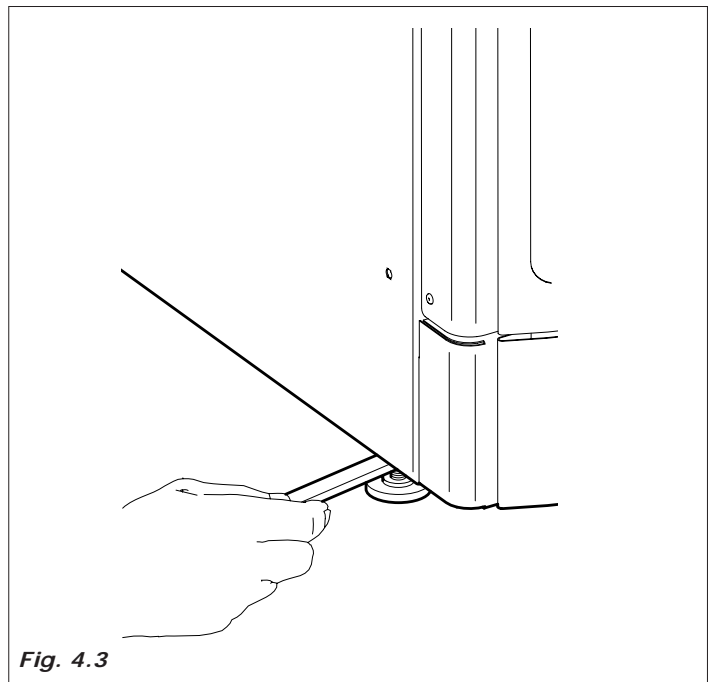

Fig. 4.3



4.2 Connection to the main water supply

Before proceeding with the connection of the distributor to the water main supply verify the following water characteristics:

- that it is drinkable (eventually through an laboratory's analysis certification)
- it has a pressure comprised between 0.5 and 6.5 (bar) (if this should not be the case, use a pump or a water pressure reducer according to the case).
- install, if not present, a tap in an accessible position to isolate the machine from the water mains should it be found to be necessary (Fig.4.4).
- before making water connections, make some water flow out of the tap so as to eliminate possible traces of impurities and dirt (Fig.4.5)
- connect the cock to the distributor, using a pipe in nylon material suitable for food products and suitable for the mains pressure. In the event of the use of a flexible pipe it is necessary to fit the reinforcement bush supplied inside (Fig. 4.6).
- the foreseen connection is a 3/ 8 gas (Fig.4.7).

4.3 Main Power supply connection

The distributor is predisposed to function with mono-phase 230 Volt tension and is protected with 12,5A and 20A fuses. (10A and 20A for the single boiler and instant versions and 15A and 20A for the instant hot/cold version).

We suggest to check that:

- the tension of net of 230 V doesn't have a difference of more than $\pm 6\%$
- The power supply output is able to bear the power load of the machine.
- use a system of diversified protection
- position the machine in such a way as to ensure that the plug remains accessible

The machine must be connected to earth in observance with the current safety norms.

For this reason, verify the plant's earth wire connection to ascertain that it is efficient and it answers national and European safety electric standards. If necessary require the intervention qualified personnel for the verification of the plant.

- The distributor is equipped with a power supply cable of H05VV-F 3x1,5mm², with SCHUKO plug (Fig.4.8).
- The sockets that are not compatible with that of the machine must be replaced. (Fig.4.9).
- The use of extension, adapters and/ or multiple plugs is forbidden.
- In some models, specific plugs are assembled for the destination place.

Bianchi Vending Group spa declines all responsibility for damages deriving for the complete or partial failure to observe these warnings.

Should the power cable be found to be damaged, immediately disconnect from the power socket.



The power supply cables are to be replaced by skilled personnel.

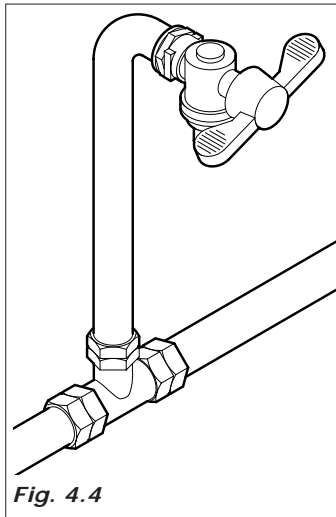

Fig. 4.4

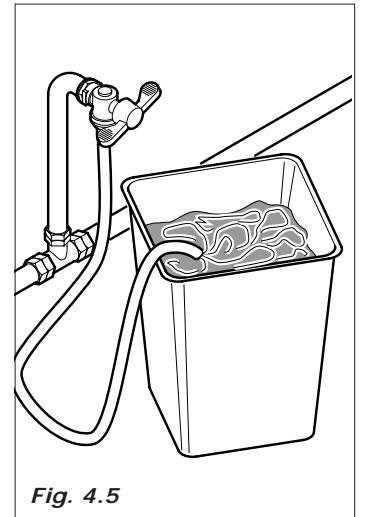

Fig. 4.5

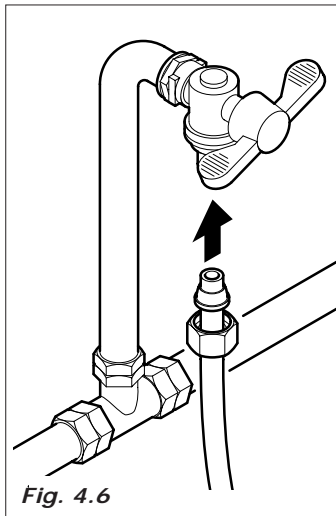

Fig. 4.6

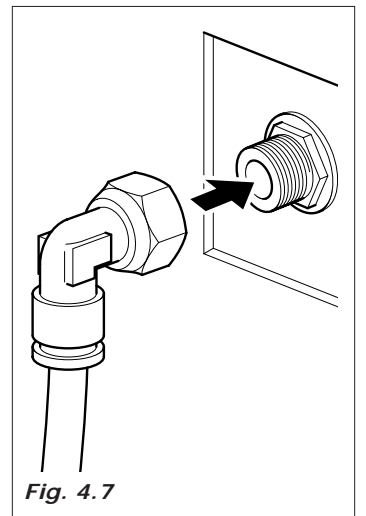

Fig. 4.7

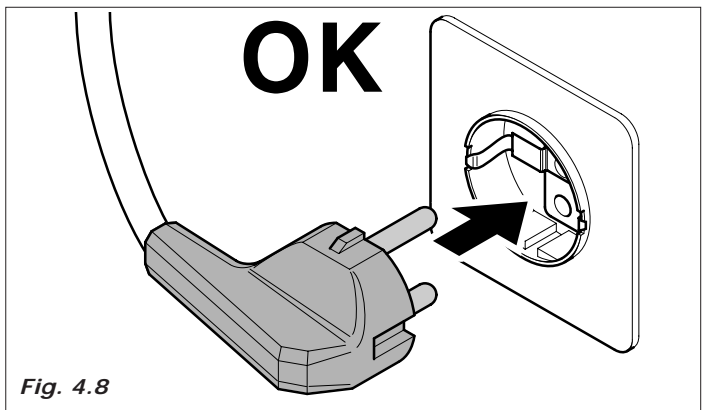

Fig. 4.8

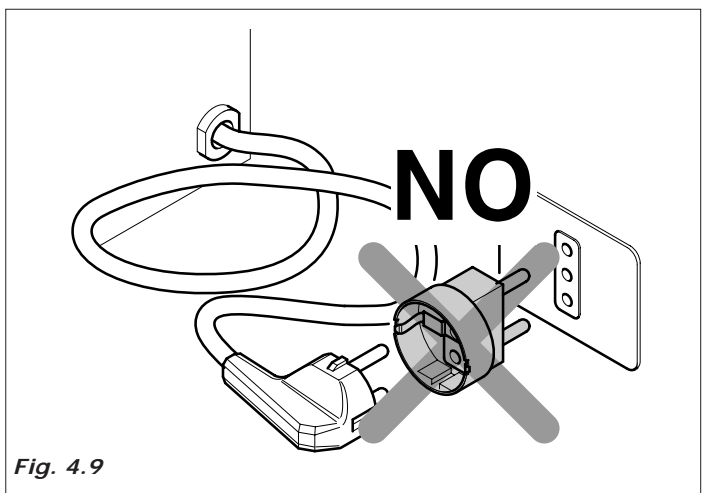

Fig. 4.9



4.4 Starting up of the unit

The distributor is equipped with a safety switch (Fig.4.10) that disconnects the machine whenever the door is opened (see electric schema).

In case of necessity, therefore, open the door or disconnect unplugging of the machine from the power supply.



The clamp of the power cable junction box remain under tension (Fig.4.11-pos.1) as well as the service switch inside the distributor. (Fig.4.12-pos.2).

- For some operations is however necessary operate with the door open but with the distributor connected.
It is possible for installation technician, to operate in this way, by inserting the special plastic key, supplied with the distributor, into the door switch and rotating it 90° (Fig.4.13-pos.3).



The opening and the possible connection with the distributor's door open must be performed only by authorized in carrying out these operations.

Don't leave the distributor open and unguarded.

Give the key only to qualified personnel.

Any time the distributor is switched on there is a diagnosis cycle to check the state of DA peripherals and perform the restoration of moving parts.

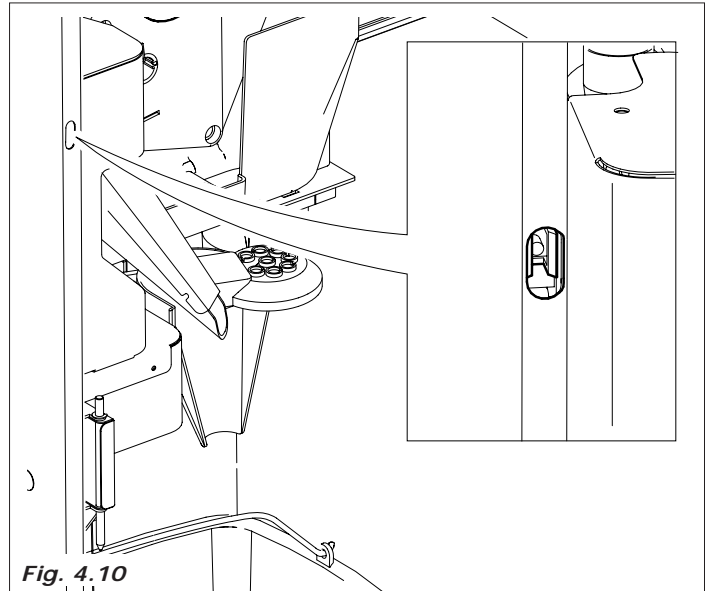

Fig. 4.10

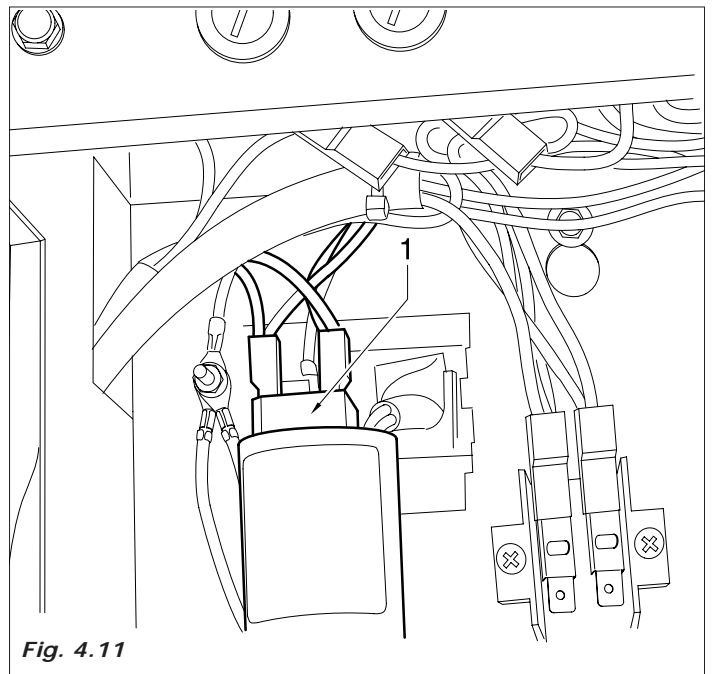

Fig. 4.11

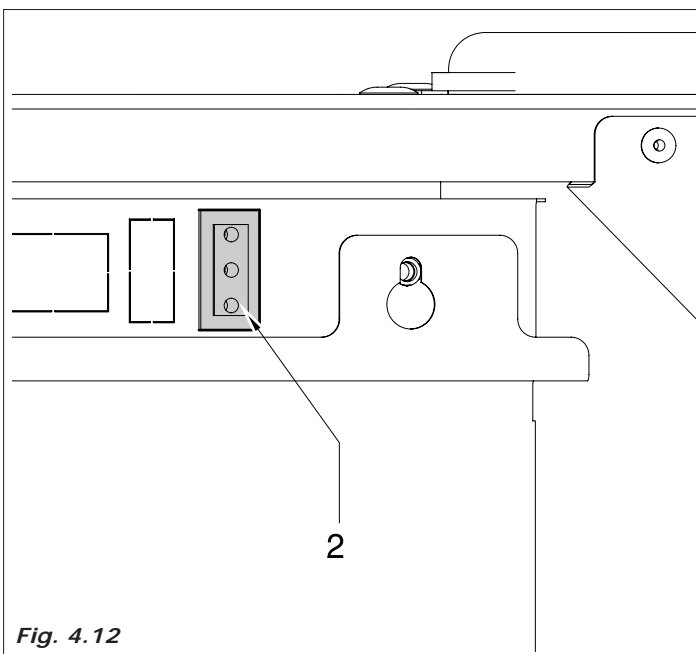

Fig. 4.12

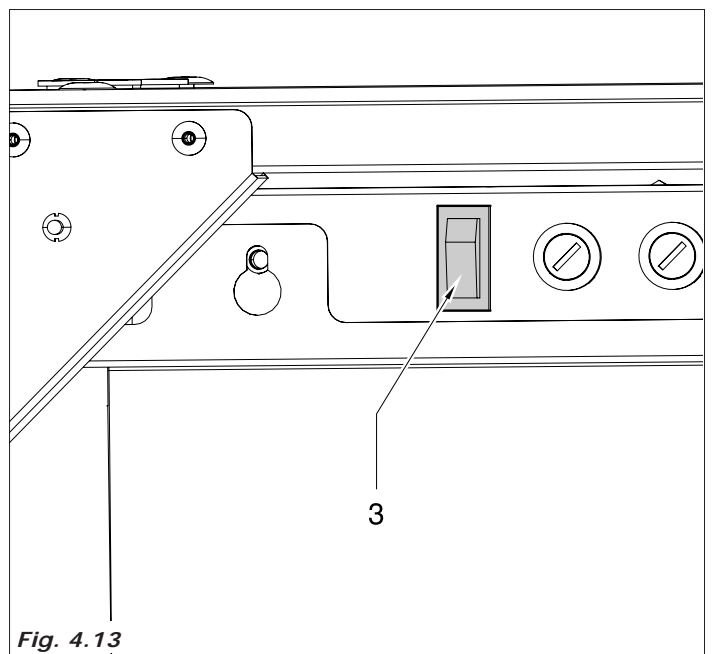

Fig. 4.13



4.5 Installation

4.5.1 Decalcificator resin washing where it is installed as accessory

First of all fill the distributor's water circuit, it is advisable effect the water softener resin regeneration (if installed) operating in the following manner:

- insert the pipe of the bottom faucet in a container suitable for this use
- open the faucet (Fig.4.14)
- insert the key in the door switch (Fig.4.13)
- Let the water flow until it is clear (Fig. 4.15).
- Take out the key and close the faucet (Fig.4.13).

LE1700 assembles as standard the Brita filter with Acquaquell cartridge 1.5 and does not provide for the above mentioned procedure application. In this case, just link DA to the mains and proceed with the hydraulic circuit filling.

4.5.2 Filling of water circuit



INSTALLATION PROCEDURE

The installation procedure is valid only for the single boiler distributors. In particular, espresso boiler and polisulphone boiler fitted with level probes.

EXPRESSO SINGLE BOILER

At the line output, the distributor will be put in condition of FIRST INSTALLATION. As soon as it reaches the location, the operator will link only water (both in case of water supply connection and autonomous tank) and the mains.

The distributor will automatically require water until micro lack of water reaches N.C. for at least 15 seconds. In this condition D.A. switches on the pump and, with resistance OFF, will supply 200 cc of water (measured through the fan). Following this procedure the distributor installation date is stored. Once the date has been confirmed, D.A. waits 10 seconds and soon after it will start to heat water in the boiler.

POLISULPHONE BOILER with LEVEL PROBES

At the output of BV lines the distributor will be put in condition of FIRST INSTALLATION. As soon it reaches the location the operator will link only water (both in case of water supply connection and autonomous tank) and the mains.

The distributor will automatically require water until the maximum level probes detect the presence of water. After this procedure the distributor installation date is stored. Once the date has been confirmed, D.A. waits 10 sec and soon after it will start to heat up water in the boiler.

SINGLE STAINLESS STEEL BOILER FOR SOUPS

At the output of BV lines, the distributor will be put in condition of FIRST INSTALLATION.

As soon it reaches the location the operator will link only water (both in case of water supply connection and autonomous tank) and the mains.

The distributor, in condition of OFF resistance, will automatically require water and will open the electrovalve 2 to vent air which is in the boiler.

This condition will last 200 seconds. At the end of this timeout, the distributor will close the electrovalve 2 and the input water ev for 20 sec. After this period, the water loading will last until the micro lack of water is N.C. for a time exceeding 5 sec (this operation is linked to a second timeout of 200 seconds). In this condition D.A. automatically activates the electrovalve 2 which will supply 20 s of water.

At the end of the supply, the micro lack of water returns become N.C. After this procedure the distributor installation date is stored. When the date is confirmed, D.A. waits 10 seconds and soon after it will start to heat up water in boilers.

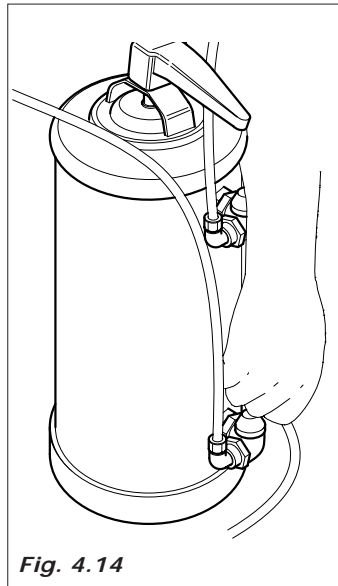

Fig. 4.14

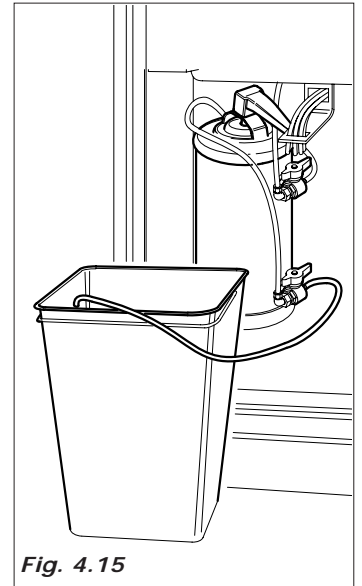

Fig. 4.15

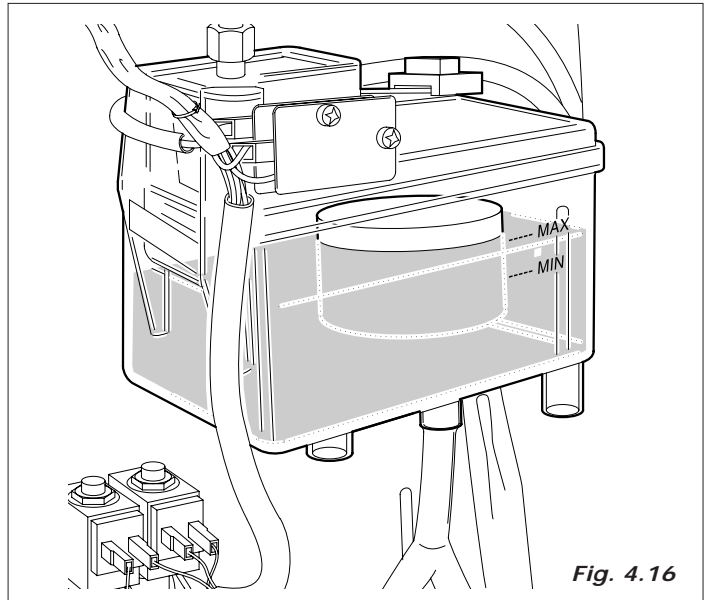

Fig. 4.16

DOUBLE BOILER

At the output of the lines, the distributor will be put in condition of FIRST INSTALLATION. As it reaches the location the operator will link only water (both in the case of linking to the mains and autonomous tanker) and the mains.

The distributor, in condition of resistances OFF, will automatically require water and will open the electrovalve 2 to vent the air which is in the stainless boiler.

This condition will last 200 seconds. At the end of this timeout, the distributor will close the electrovalve 2 and the water input ev for 20 sec.

After this time water loading will continue until the micro lack of water is N.C. for a time exceeding 5 sec (this operation is linked to a second timeout of 200 seconds). In this condition the D.A. activates the electrovalve 2 and will supply 20 sec of water.

At the end of the supply, the micro lack shall return to N.C. After 10 sec D.A. activates the espresso pump, and, on condition of resistance OFF, it will supply 20 cc of water through the coffee ev (measured through the fan).

After this procedure, the distributor installation date is stored. When the date is confirmed, D.A. waits 10 seconds and soon after it will start to heat up water in the 2 boilers.

At the end of the water filling, effect a cleaning cycle of the mixer group so as to fill all the circuits and remove eventual residues from the boiler (Fig.4.17).

Before connecting the power supply, ensure that the distributor has been connected to the water mains and that the water tap has been turned on.

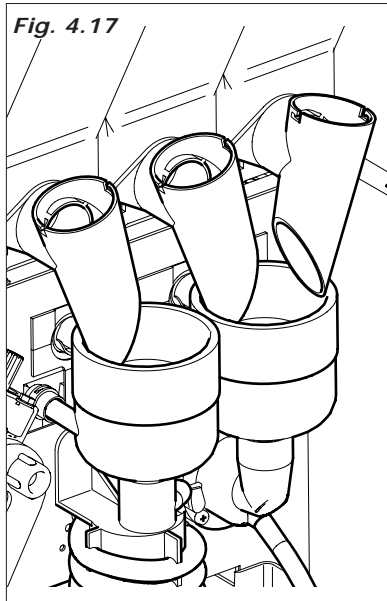

Fig. 4.17

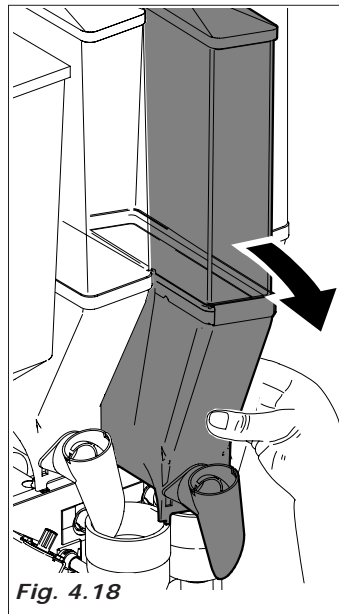

Fig. 4.18

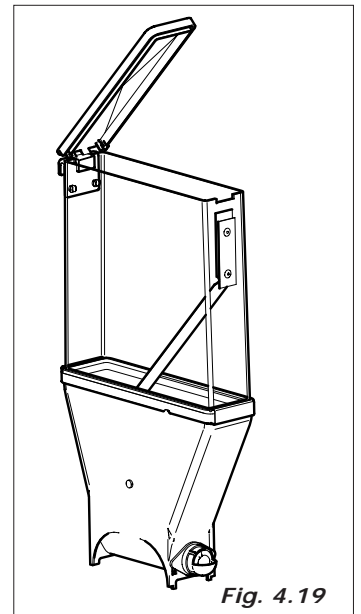

Fig. 4.19



4.5.3 Cleaning of the parts in contact with food substances

With distributor switched on effect a cleaning of the mixers pressing the buttons according to what is described in the service functions so as to eliminate any dirt from the coffee boiler and the instant boiler.

- wash your hands carefully
- prepare an anti-bacterial cleaning solution with a chlorine base (products that can be purchased in pharmacies) carefully following the indications on the product instruction labels.
- remove all the product containers from the distributor (Fig.4.18)
- remove the lids from the product containers covers and product chutes (Fig.4.19). Dip all in the solution previously prepared
- remove all the powder chutes, water funnels, mixing bowls and whippers and silicone tubes and dip these parts also in the prepared solution (Fig.4.20)
- with a cloth soaked with the solution clean the whipper assembly base (Fig.4.21)
- the parts must soak in the solution for the time indicated on the solutions' instruction label.
- Recover all the parts, rinse them abundantly, dry them perfectly and proceed with the re-assembly in the distributor.

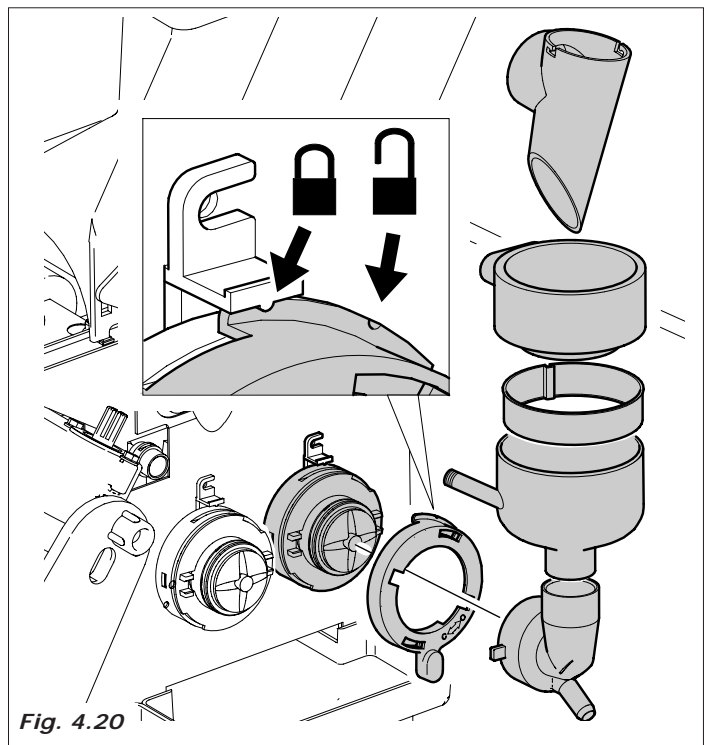

Fig. 4.20



For further safety after the assembly of the parts, effect some automatic cleaning cycles so as to eliminate any eventual residues.

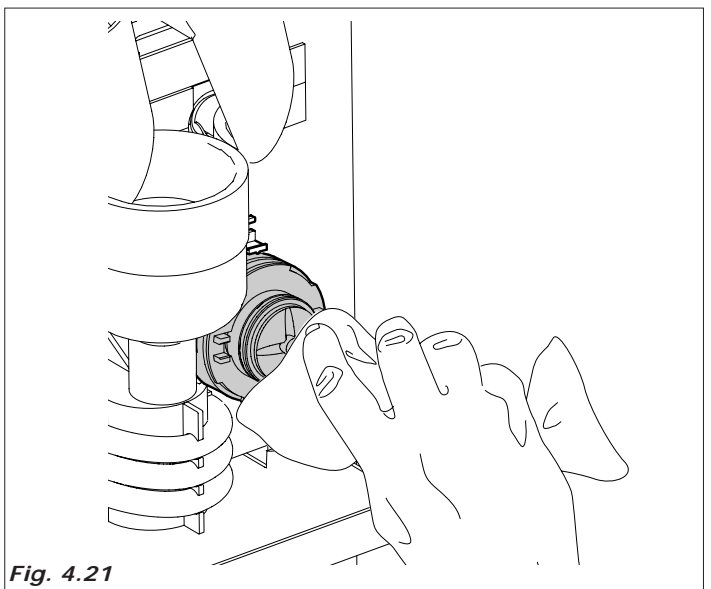

Fig. 4.21



4.5.4 Payment system installation

The distributor is supplied without any payment system:
The installation of the payment system is the responsibility of the installation technician.

Bianchi Vending Group spa will not take responsibility for any eventual damage to the machine itself and/or to things and/or persons due to incorrect installation.

- open the board and coin mechanism protection door (Fig. 4.22)
- Connect the payment system (Fig.4.23) to the Master board.

The selectors must be directly connected to the Master board the and the serial executive systems through the interface cable supplied with the machine.

Then go into programming for the correct settings.

Consult chapter " 5.0 SOFTWARE INSTRUCTIONS" so as to verify setting of the parameters, that must be coherent with the system used.

Check the payment system connections, by consulting the diagram of the sheet shown.

- Hook the coin mechanism (Fig. 4.24).

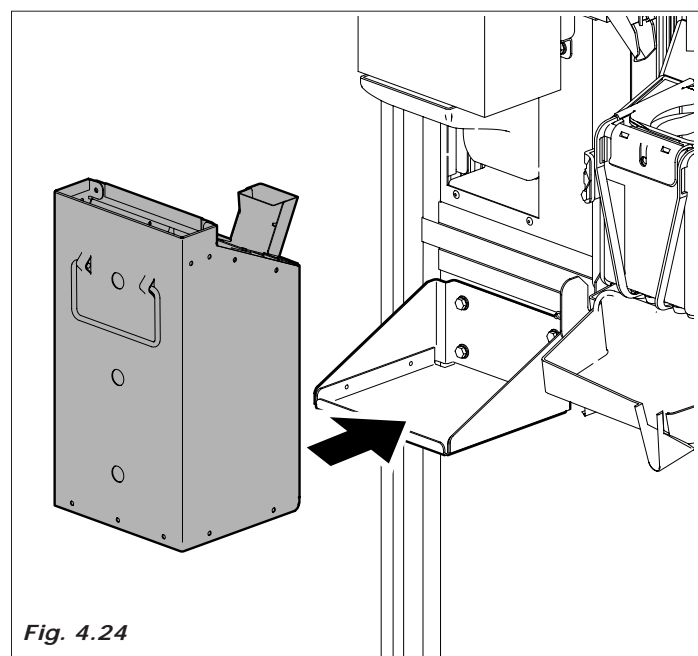
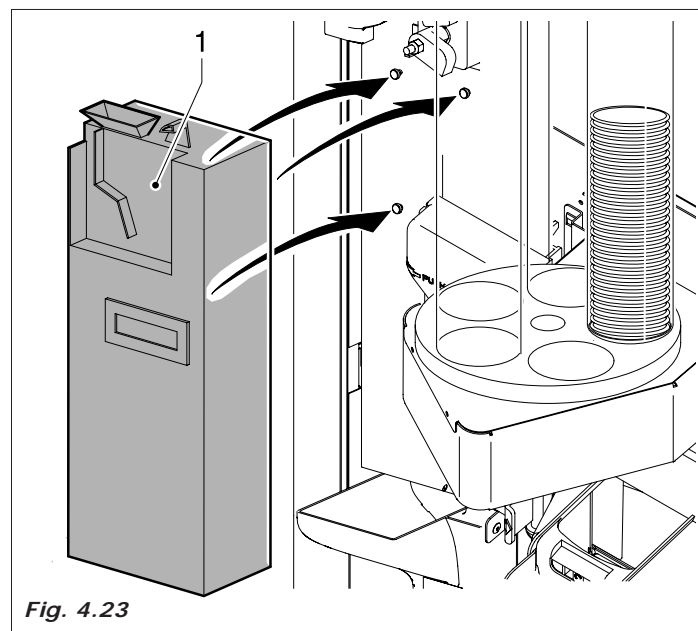
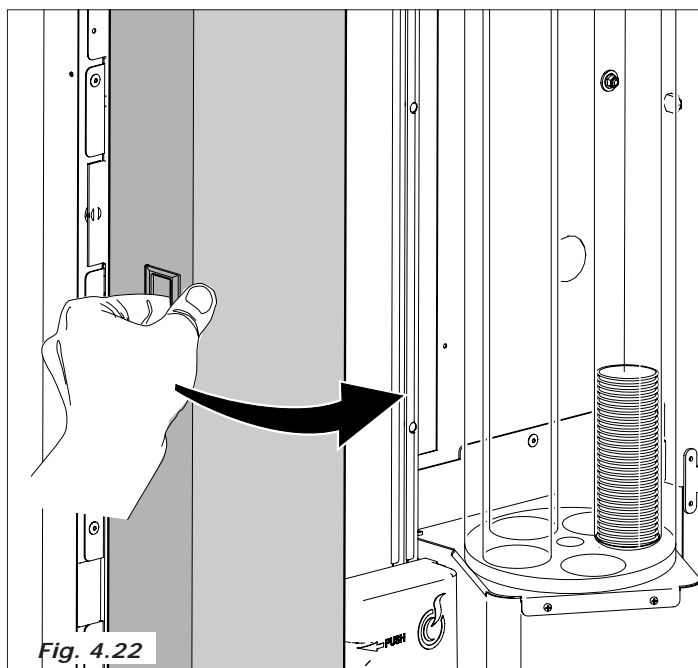



4.6 Product container loading (with machine off)

4.6.1 Loading containers

- so as to effect the loading is necessary remove each container. Particularly, for the coffee bean container, it is necessary close the chute door before removing the container (Fig.4.25).
- remove the covers of each container and load the product according to the product indicated on the label (Fig.4.26)
- pay attention that there are no clots, avoid pressing the product and using an excessive quantity, so as to avoid its aging in relation to the consumption foreseen in the time period between two loadings.



Check the container product capacity in the section TECHNICAL CHARACTERISTICS.

4.6.2 Cup loading

Use only cups suitable for automatic vending machines, (check the relevant features by consulting the chapter 1.0 “Technical Specifications.”), avoid compressing the cups between themselves during the loading. Don't try to rotate the turret manually.

First filling

In installation phase with the cup dispenser completely empty, operate as follows:

- Check that the cup column is not aligned with the distribution outlet, then fill all the columns proceeding in an anti-clockwise sense, opposite sense (when the column is aligned with the distribution outlet), close the door and switch on the machine so that the cup column rotates and automatically places itself in a position in which it is not aligned with the inlet and then proceed to fill (Fig.4.27)
- Put the cup turret's lid back on and snap in the spring band (Fig. 4.28).

Normal filling

The cup column should normally filled with the machine off, simply by opening the front door, lifting the lid and inserting the missing cups.

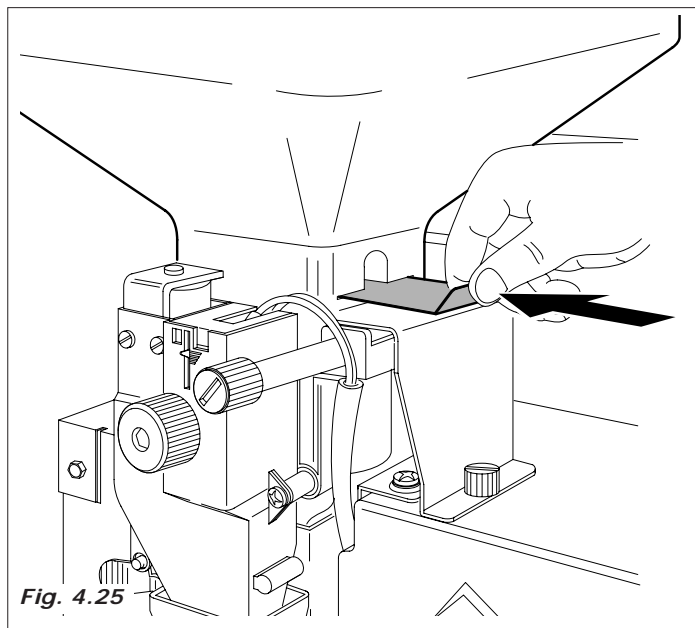

Fig. 4.25

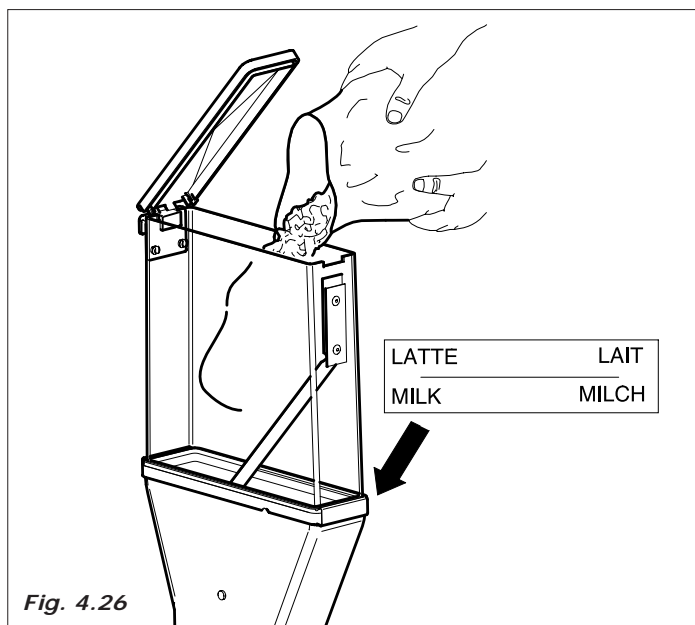

Fig. 4.26

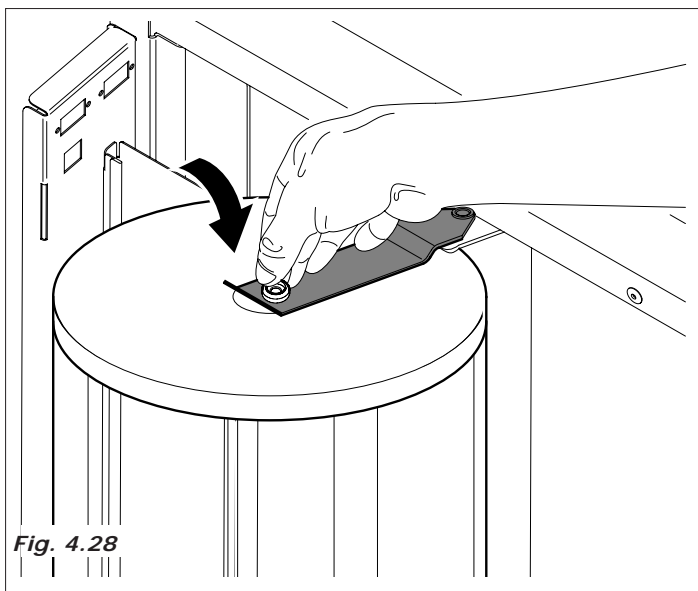

Fig. 4.28

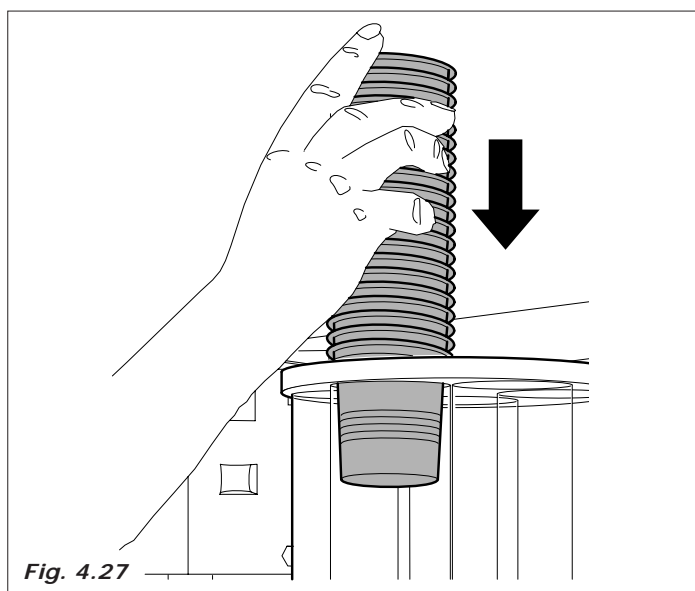

Fig. 4.27

4.6.3 Spoon loading

Attention! Only use appropriate stirers to be used in automatic vending machines.

- Remove the metal weight from the spoon dispensing column (Fig. 4.29)
- insert the spoons with their pack wrapping in the column and when they are positioned on the bottom cut and remove the wrapping (Fig. 4.30)
- once the loading is completed put the weight back in the spoon dispensing column.
- Check that the spoon are cut burr-free, that they are not bent and that they are all placed horizontally (Fig.4.31).

4.6.4 Insertion of waste grounds bag

- insert the plastic bag wrapping it on the support itself (Fig. 4.32)
- Use plastic bags that are sufficiently long so that they touch the bottom of the distributor.
- Make sure that the liquid collection tank is in the correct position (Fig. 4.32) and periodically empty it.

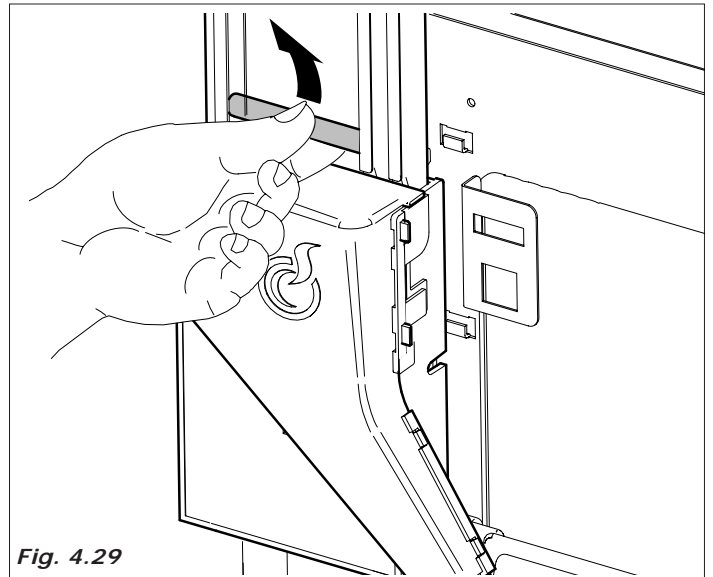

Fig. 4.29

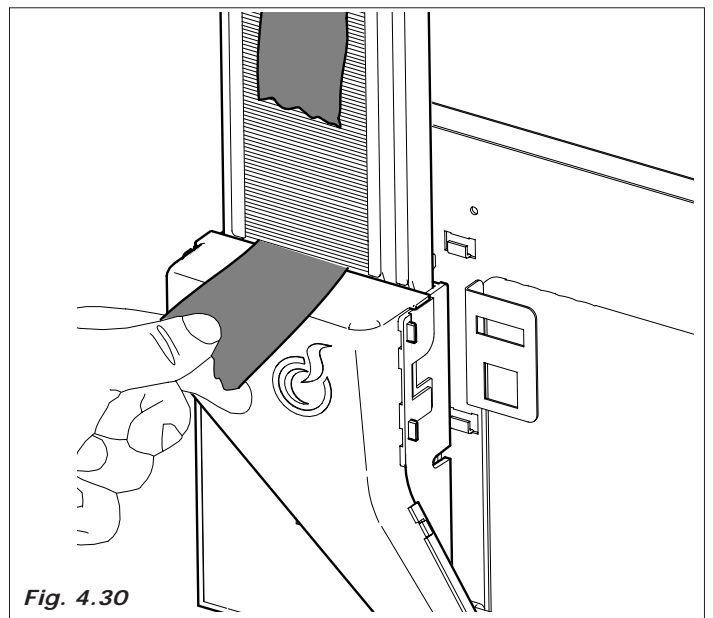

Fig. 4.30

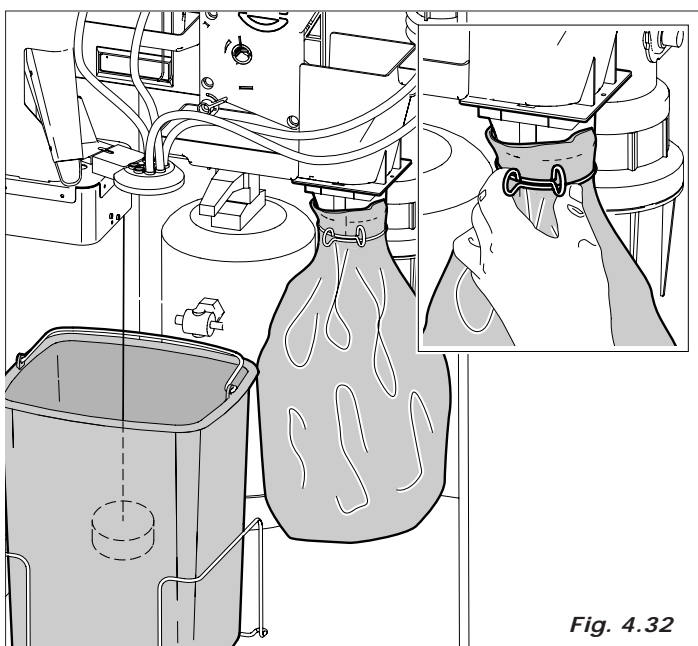

Fig. 4.32

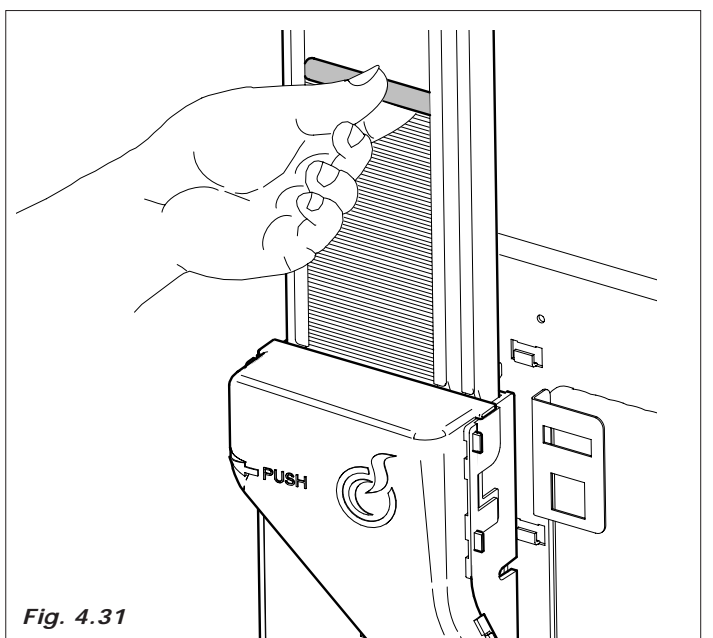

Fig. 4.31

4.7 AUTOMATIC DISTRIBUTOR LAYOUT

LAYOUT LEI 700 ES01BVG

With the new dose menu we have the possibility to create selections with the required sequences.

Therefore any selection can be combined, creating a maximum sequence of 3 electrovalves; each electrovalve can be coupled to 2 products at most.

These couplings are factory made, therefore, for a correct use of the distributor we should keep strictly to the following indications.

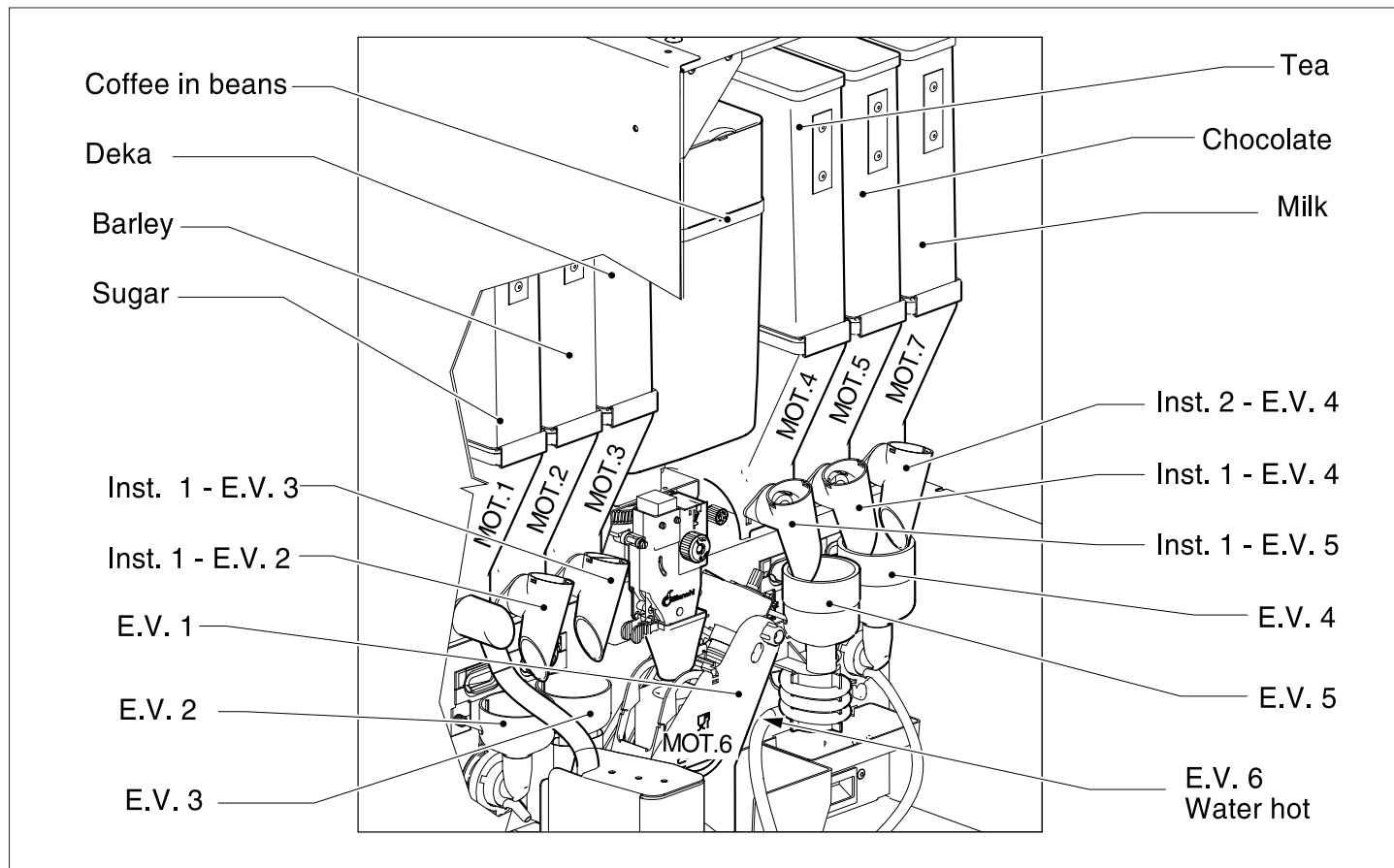

	FIRST SOUP	SECOND SOUP
EV1 Coffee	0	0
EV2	Barley	0
EV3	Deka	0
EV4	Tea	0
EV5	Chocolate	Milk
EV6 Water	0	0

LAYOUT LEI 700 ES02BVG (TOP)

With the new dose menu we have the possibility to create selections with the required sequences.

Therefore any selection can be combined, creating a maximum sequence of 3 electrovalves; each electrovalve can be coupled to 2 products at most.

These couplings are factory made, therefore, for a correct use of the distributor we should keep strictly to the following indications.

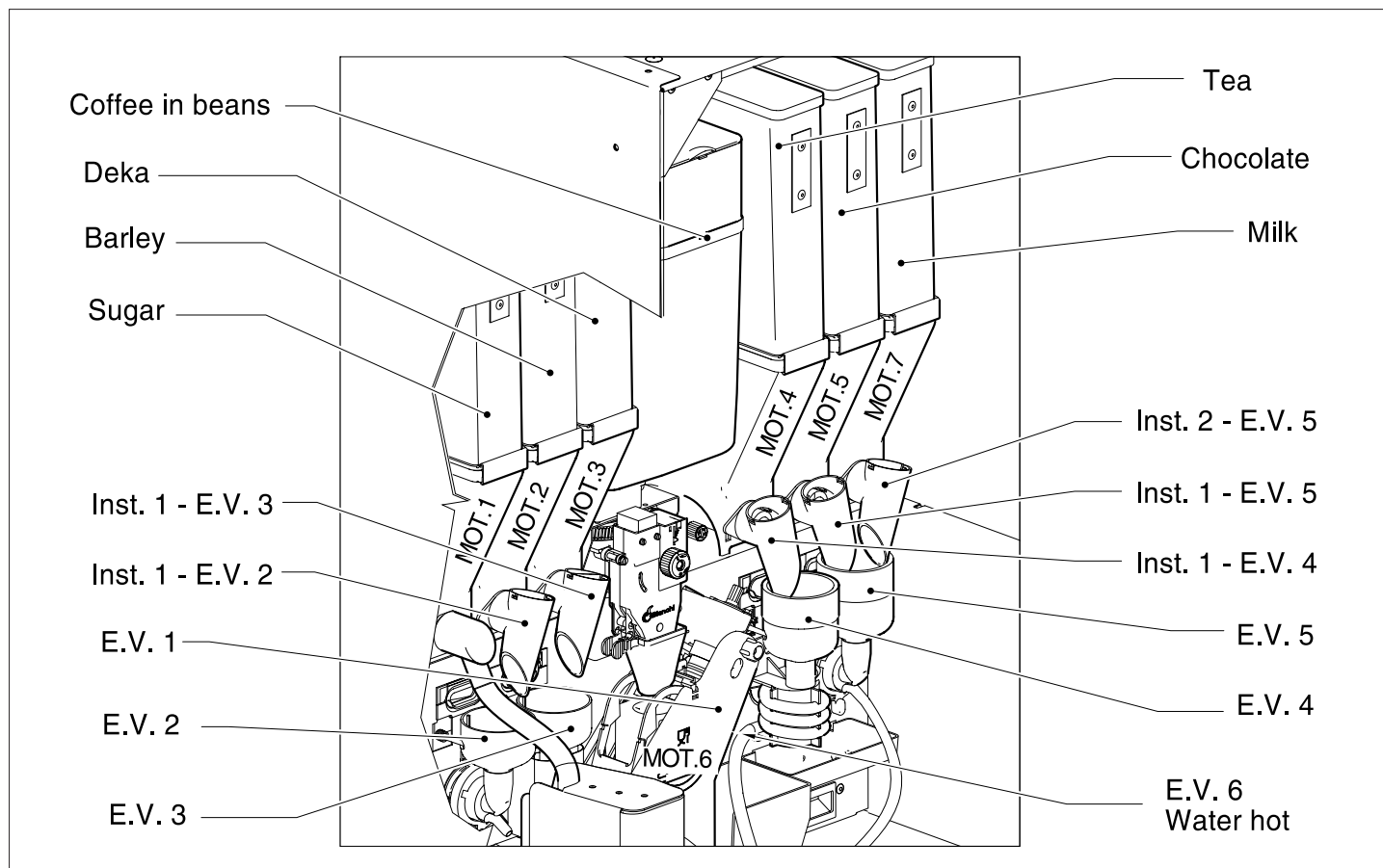

	FIRST SOUP	SECOND SOUP
EV1 Coffee	0	0
EV2	Barley	0
EV3	Deka	0
EV4	Tea	0
EV5	Chocolate	Milk
EV6 Water	0	0

LAYOUT LEI 700 ES02BVG (TOP) Double grinder

With the new dose menu we have the possibility to create selections with the required sequences.

Therefore any selection can be combined, creating a maximum sequence of 3 electrovalves; each electrovalve can be coupled to 2 products at most.

These couplings are factory made, therefore, for a correct use of the distributor we should keep strictly to the following indications.

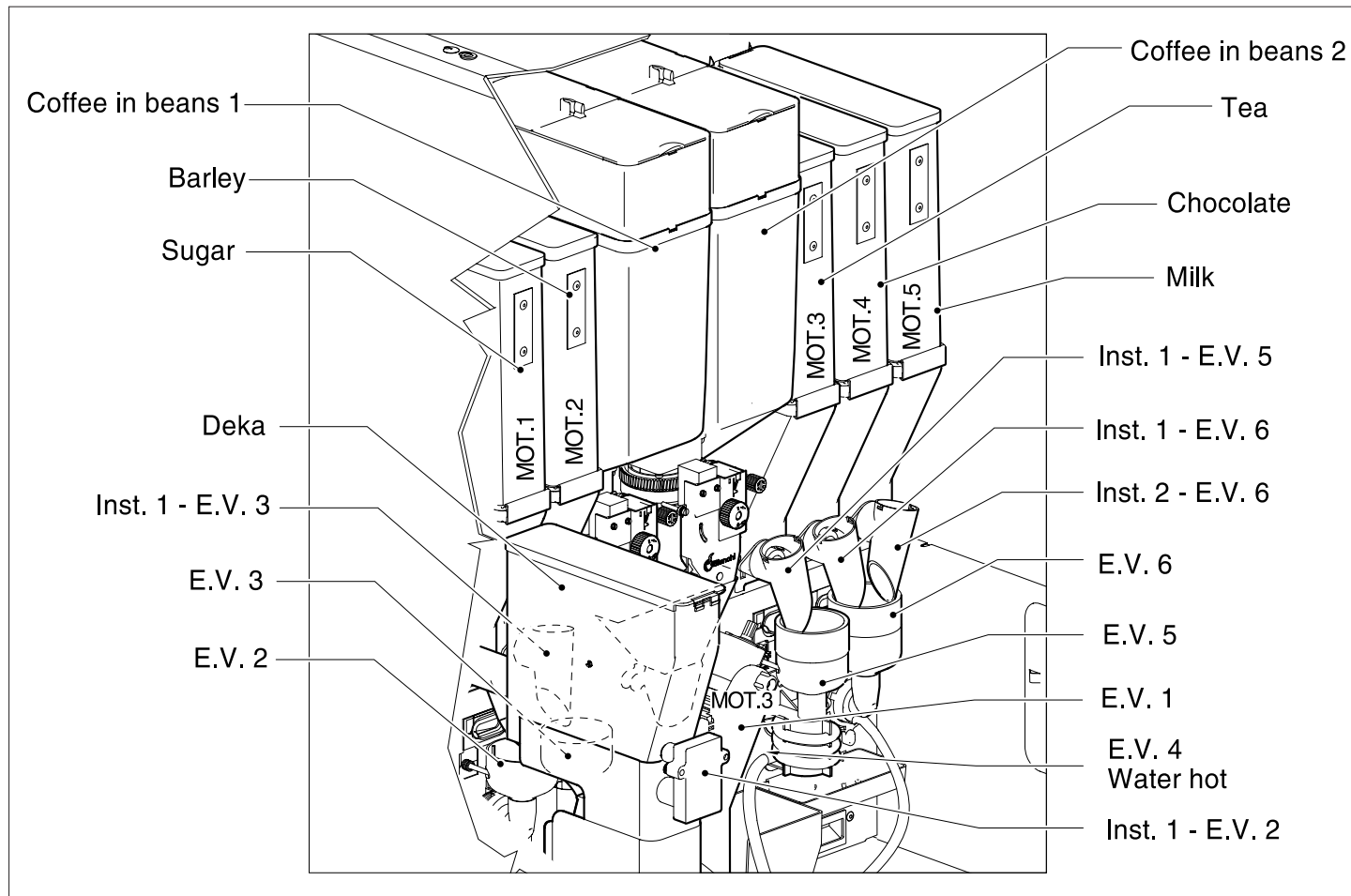

	FIRST SOUP	SECOND SOUP
EV1 Coffee	0	0
EV2	Barley	0
EV3	Dekka	0
EV4	Tea	0
EV5	Chocolate	Milk
EV6 Water	0	0

LAYOUT LEI 400 ESPRESSO

With the new dose menu we have the possibility to create selections with the required sequences.

Therefore any selection can be combined, creating a maximum sequence of 3 electrovalves; each electrovalve can be coupled to 2 products at most.

These couplings are factory made, therefore, for a correct use of the distributor we should keep strictly to the following indications.

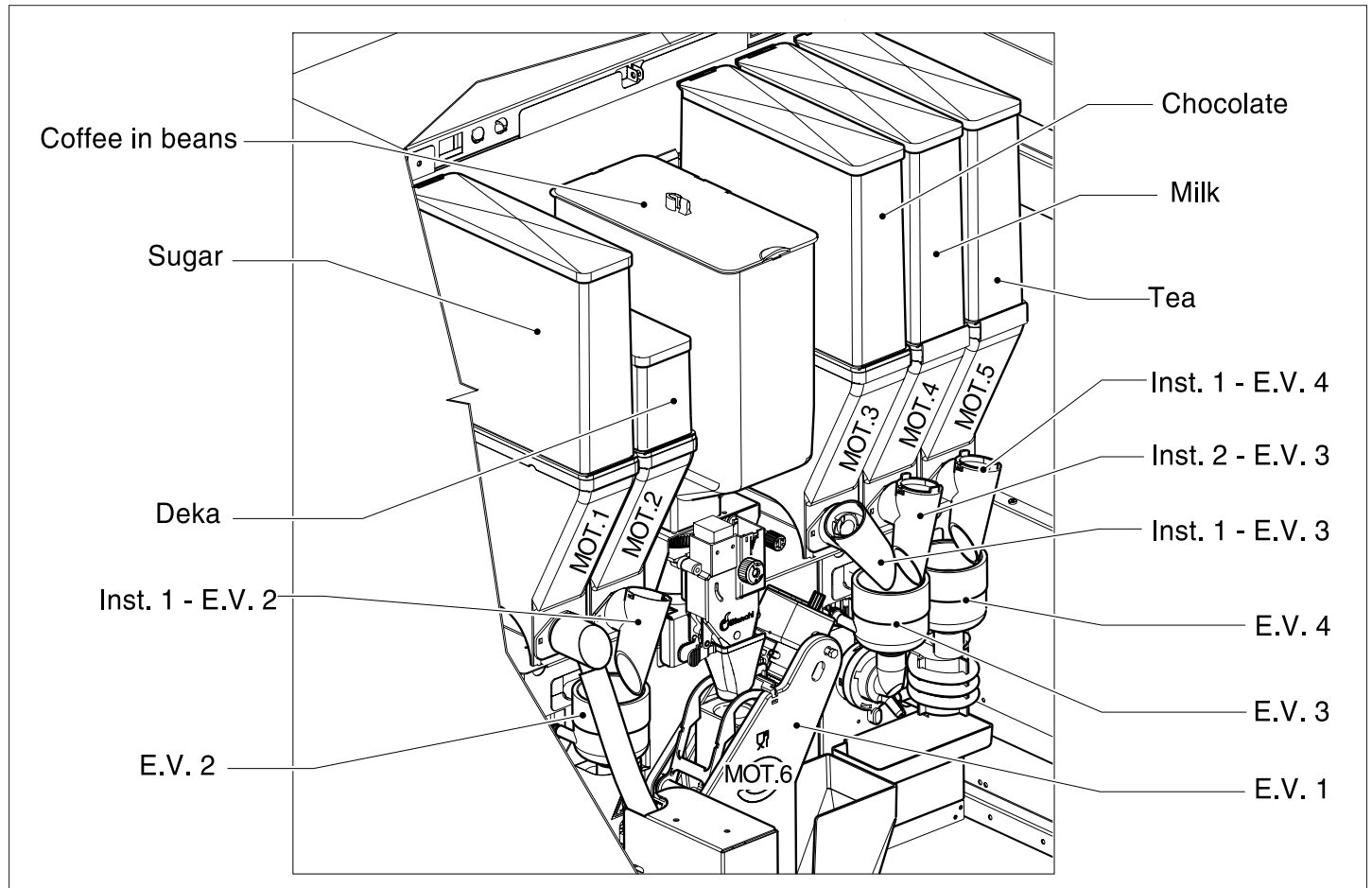

	FIRST SOUP	SECOND SOUP
EV1 Coffee	0	0
EV2	Deka	0
EV3	Chocolate	Milk
EV4	Tea	0

4.8 FIRST SELF INSTALLATION MODE

At the first machine start up will be performed a self installation .The aim of this procedure is to avoid the manual connections of wires on the boards after the filling of the Hydraulic cyrcuit.

For Espresso single boiler:

When the distributor is started up the airbreak is filled with water.

When the floater is in the upper position the machine will start loading water automatically and this will go on until 200cc of water are counted by the fan (then water will be supplied via a mixer throughout the procedure).

The procedure will be carried out with resistance off.

At the end a date will be shown on the display.

For Espresso Double boiler

When the distributor is started up the airbreak is filled with water.

When the floater is in the upper position the machine will start the automatic installation process and following loading of both boilers (then water will be supplied via a mixer and by the 3-way Coffee EV throughout the procedure).

The procedure will be carried out with resistance off.

At the end a date will be shown on the display.

For Instant boiler :

When the distributor is started up the airbreak is filled with water.

When the floater is in the upper position at least for 5 consecutive seconds the machine will open an instant electrovalve and start a water loading cycle in the boiler (then water will be supplied via a mixer throughout the procedure)

The procedure will be carried out with resistance off.

At the end a date will be shown on the display.

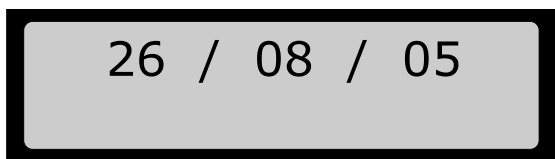

Now we must enter the installation date using the push button panel as shown below:

Mod. LEI700

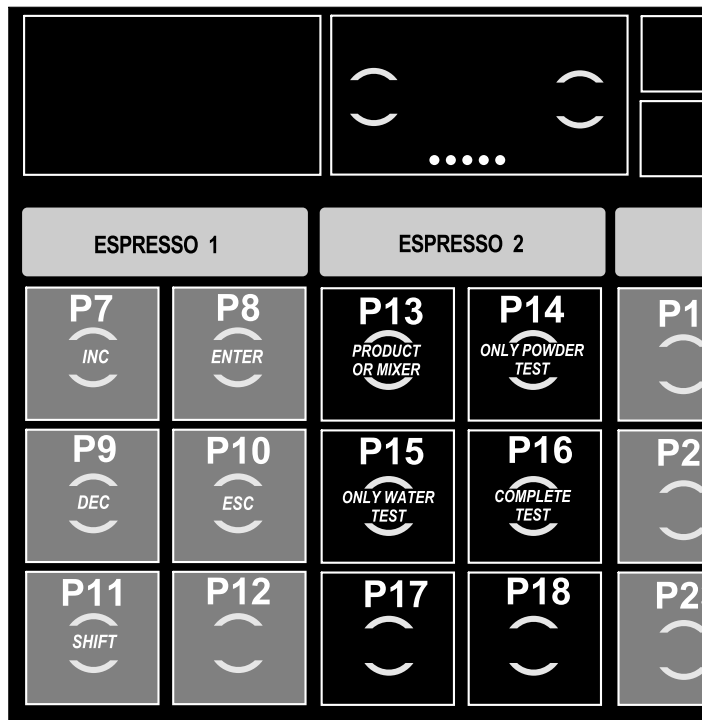

Mod. LEI400

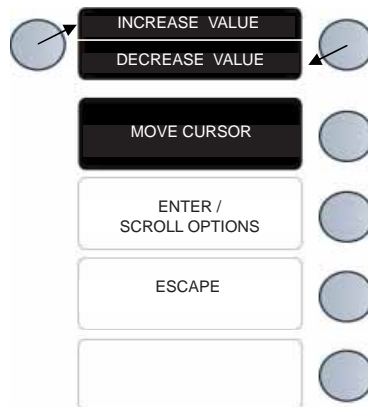

Pushing the ENTER BUTTON , the machine will wait for 10 seconds then will start to warm up the boiler.

The date will be stored in a safe place of the board.

To restore the first installation mode, go to Programming using Password 22933.

5.0 SOFTWARE INSTRUCTIONS

5.1 PASSWORD

The current programming logic requires, when entering by pressing the PROG key, the insertion of a password allowing to access one programming menu.

To facilitate and speed up some operations on the field, the password management is subdivided as follows:

PWD 1 - Reduced programming menu (00001)

PWD 2 – Sales Menu (00000)

Note: If the password of the reduced menu coincides with the password of the complete menu, the latter will prevail.

5.2 MACHINE MENUS

PWD 1 allows the access the complete menu of the vending machine. The menu access procedure is as follows: press PROG key on the master board, enter the password and press ENTER key. Below is a list of programming menus of the vending machine.

5.2.1 WINBIANCHI MENUS

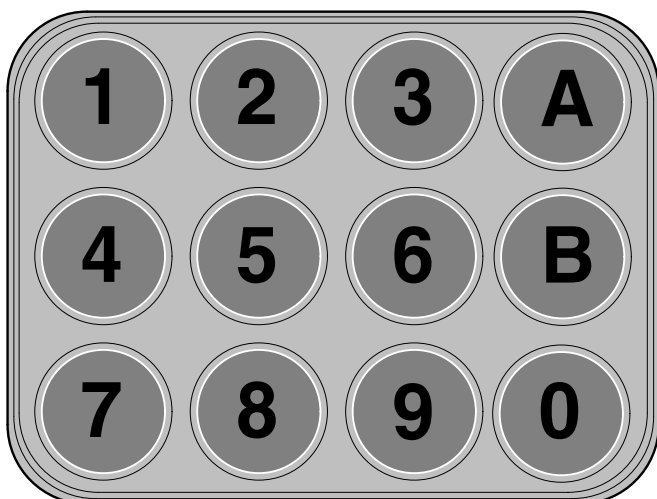
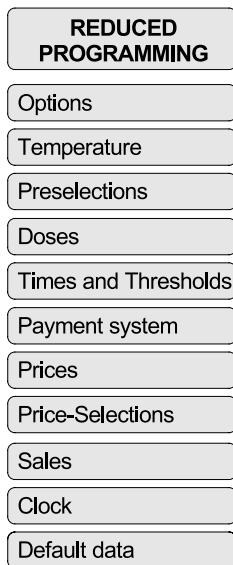

For Alphanumeric version

IN PROGRAMMING MODE, THE KEYS HAVE THE FOLLOWING MEANINGS:

- P7** inc
- P8** enter
- P9** dec
- P10** Esc
- P11** shift
- P13** In the doses selections menu: shows name of box or mixer
- P14** In the doses selections menu: performs only soluble powder test
- P15** In the doses selections menu: performs only water test
- P16** In the doses selections menu: performs complete test

- P1** Alphanumeric keypad Inc
- P2** Alphanumeric keypad in the Activate lift menu: lift positions programming input
- P3** Alphanumeric keypad Shift
- P5** Alphanumeric keypad Esc
- P7** Alphanumeric keypad Dec
- P9** Alphanumeric keypad Enter
- PA** Alphanumeric keypad
In the lift positions programming menu: Lift UP
- PB** Alphanumeric keypad
In the lift positions programming menu: Lift DOWN

Programming keypad LEI 700

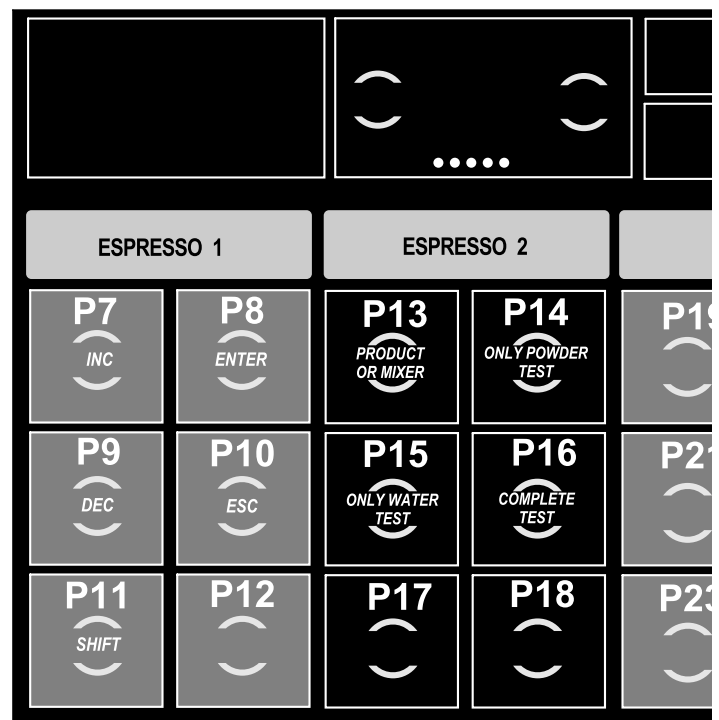

Programming keypad LEI400

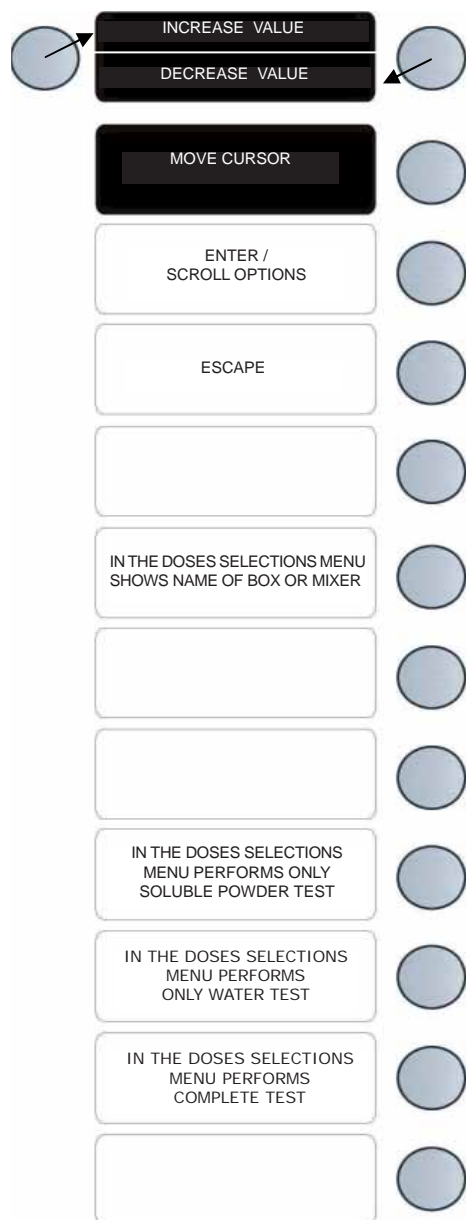

5.3 PROGRAMMING MENU

5.3.1 'Options' Menu

Language	Language [Italian, French, English, Spanish, German, Dutch, Portuguese, English, Catalan]
Cleaning	Enables cleaning with clock [On/Off]. Displayed and settable only with machine with espresso/Instant/FB boiler.
Cleaning cycle	Enables cleaning cycle [On/Off]. It enables a mixer cleaning after 30 minutes from activation which is followed by a second cleaning after 12 hours without preparations. Therefore a daily cleaning of the mixer is ensured. Visible and settable only with machine with espresso/Instant/FB boiler.
Always spoon	Enables spoon management- Yes/No. If always spoon yes, the spoon is always provided, if always spoon no, the item spoon will appear in the doses menu. It will therefore be possible for any drink to manage the spoon supply.
Spoon after Yes/No	If No the spoon is supplied upon selection beginning, if Yes the spoon is supplied after sugar in sweet drinks and after water dose in bitter drinks.

5.3.2 'Temperature' Menu

Boiler Temp. 1 Slave X	Boiler 1 temperature. Espresso boiler has a range [70÷110 °C] Instant Stainl.steel boiler has a range [70÷90 °C] The wording Slave X indicates the slave number linked to the MASTER distributor.
Boiler Temp. 2 Slave X	Boiler 2 temperature. Espresso boiler has a range [70÷110 °C] Instant Stainl.steel boiler has a range [70÷90 °C] The wording Slave X indicates the slave number linked to the MASTER distributor.
Temp.1 Tank Slave X	Temperature of probe 1 of Tank A [5÷15 °C for SNACK model and 1÷15 °C for PAN model , >15 °C = Off] It sets the working temperature of the distributor.The wording Slave X indicates the slave number linked to the MASTER distributor.
Temp.2 Tank Slave X	Temperature of probe 2 of Tank A [5÷15 °C for SNACK model and 1÷15 °C for PAN model , >15 °C = Off] It sets the working temperature of probe 2 of the distributor. If it has to cool it switches on the fan output in the new board with 2 probes. The wording Slave X indicates the slave number linked to the MASTER distributor. Displayed only if Cool Distributor Probe is 2.

5.3.3 'Preselections' Menu

All push buttons can be used as preselection:

Push button 01...30

Without product

Product [0...9] 0= disabled

This type of preselection allows to select the relevant product. When this preselection is pressed the first 3 characters on the display are reserved to the wording "NO ". The remaining 10 characters will display the product to be entered using the "graphic configuration" window of the windows program of the current software.

For example, if the product is Milk, the message will be "NO milk". The function of this preselection is to set to zero the programmed dose in the drink of the relevant instant product. There can be several selections of this type coupled to different products.

Double product [0...9] 0= disabled Applicable only for drinks with espresso or instant coffee. It replaces the coffee with the selected instant drink.

INC+ / DEC - Sugar

T sugar [0...25.5 s]

H₂O [0...25.5 s] o [0...999 cc] For instant drinks only

Generic preselection: The parameters that can be programmed are: product, product time, product water, time + product, water + product, enable stop and enable extra.

Enable Stop will prevail on Enable Extra. When Stop is set the programmed time is not considered but when a button of a drink is pressed the scrolling squares will be displayed waiting for the stop. Upon Stop the instant product dose is calculated and the preparation is started.

There can be several Stop preselections coupled to different products ; in this case they will be displayed one after the other and in any case only if the drink includes the preselected product. Extra can be enabled only if Stop is Off. It sets if the preselection is managed as - and -- (Extra=Off) or + and ++ (Extra=On). - and -- deducts the programmed doses from the dose of the drink to be prepared while + and ++ adds them. By pressing once the display will show - or + and show the deduction or the addition of the product time doses, product water doses; by pressing again (before the preselection timeout elapses) the display will show – or ++ and also the time + product and water + product doses are deducted or added. There can be several preselections coupled to different products.

Cup

No Cup

5.3.4 'Doses' Menu

Button XX	Selection of the button to be configured: [1...30] for linear keyboard [1...32] for multibrand keyboard, [1...12] for antivandalism keyboard. [Ivs] for IVS keyboard refer to paragraph 3.2.1. IVS keyboard [] for Old Style keyboard.
Drink	Enable drink [On/Off]
Spoon?	Enables spoon distribution [Yes/No] (Only if Spoon distributor Yes and Always Spoon No in Configuration Menu).
Cup?	Enables cup distribution [Yes/No] (Only if Cup Management Yes and Always Cup No in Configuration Menu)
First E.V. X	Number 1 ^EV [0-Wafer 1 Wafer 2, Coffee 1-Coffee 2...8- Cold] 0=E.V. not coupled to this button
T first E.V.	T opening first E.V. [0...99.9 s]
R first E.V.	Opening delay first E.V. [0...25.5 s]
T Mixer 1E.V.	T Mixer coupled to first E.V. [0...25.5 s]
R Mixer 1 ^E.V.	Mixer delay coupled to first E.V. [0...25.5 s]
T product X	T first box coupled to 1 E.V. [0...99.9 s]
R product X	First box delay coupled to 1 E.V. [0...25.5 s]
Ton product X	T on motoreducer first product [0...25.5 s]
Toff product X	T off motoreducer first product [0...25.5 s]
T product X	T second box coupled to 1 E.V. [0...99.9 s]
R product X	Second box delay coupled to 1 E.V. [0...25.5 s]
Ton product X	T on motoreducer second product [0...25.5 s]
Toff product X	T off motoreducer second product [0...25.5 s]
T product X	T third box coupled to 1 E.V. [0...99.9 s]
R product X	Third box delay coupled to 1 E.V. [0...25.5 s]
Ton product X	T on motoreducer third product [0...25.5 s]
Toff product X	T off motoreducer third product [0...25.5 s]
Second E.V. X	Number 1 ^EV [0...8-Cold] 0=E.V. not coupled to this button
T 2 ^ E.V.	T opening second E.V. [0...99.9 s]
R 2 ^ E.V.	Opening delay second E.V. [0...25.5 s]
T Mixer 2E.V.	T Mixer coupled to second E.V. [0...25.5 s]
R Mixer 2 ^E.V.	Mixer delay coupled to second E.V. [0...25.5 s]
T product X	T first box coupled to 2 E.V. [0...25.5 s]
R product X	First box delay coupled to 2 E.V.[0...25.5 s]
Ton product X	T on motoreducer first product [0...25.5 s]
Toff product X	T off motoreducer first product [0...25.5 s]
T product X	T second box coupled to 2° E.V. [0...25.5 s]
R product X	2nd box delay coupled to 2 ^ E.V. [0...25.5 s]
Ton product X	T on motoreducer second product [0...25.5 s]
Toff product X	T off motoreducer second product [0...25.5 s]
T product X	T 3rd box coupled to 2 E.V. [0...25.5 s]
R product X	3rd box delay coupled to 2 E.V. [0...25.5 s]

Ton product X	T on motoreducer third product [0...25.5 s]
Toff product X	T off motoreducer third product [0...25.5 s]
Third E.V. X	Number 1 [^] EV [0...8-Cold] 0=E.V. not coupled to this button
T 3 [^] E.V.	T opening third E.V. [0...99.9 s]
R 3 [^] E.V.	Opening delay 3rd E.V. [0...25.5 s]
T Mixer 3E.V.	T Mixer coupled to 3rd E.V. [0...25.5 s]
R Mixer 3 [^] E.V.	Mixer delay coupled to 3rd E.V. [0...25.5 s]
T product X	T first box coupled to 3rd E.V. [0...25.5 s]
R product X	First box delay coupled to 3rd E.V. [0...25.5 s]
Ton product X	T on motoreducer first product [0...25.5 s]
Toff product X	T off motoreducer first product [0...25.5 s]
T product X	T 2nd box coupled to E.V. [0...25.5 s]
R product X	Delay 2nd box coupled to 3rd E.V. [0...25.5 s]
Ton product X	T on motoreducer second product [0...25.5 s]
Toff product X	T off motoreducer second product [0...25.5 s]
T product X	T 3rd box coupled to 3rd E.V. [0...25.5s]
R product X	3rd box delay coupled to 3rd E.V. [0...25.5]
Ton product X	T on motoreducer third product [0...25.5s]
Toff product X	T off motoreducer third product [0...25.5s]
T Sugar Espresso X	T sugar espresso [0...25.5 s]
T Sugar MB	T sugar [0...25.5 s] only with MultiBrand Keyboard
H ₂ O MB	Water EV sugar [0...25.5 s] only with Multi Brand Keyboard and Instant Distributor.
Double Product 1	
E.V. X	Number 1 [^] EV [0...8] 0=E.V. not coupled to this button
T E.V. d.p.	T opening- E.V. [0...99.9 s]
R E.V. d.p.	Opening delay -E.V. [0...25.5 s]
T Mixer 1E.V.	T Mixer coupled to E.V. [0...25.5 s]
R Mixer 1 [^] E.V.	Mixer Delay coupled to E.V. [0...25.5 s]
T product X	T first box coupled to E.V. [0...99.9s]
R product X	First box delay coupled to E.V. [0...25.5 s]
Ton Product X	T on motoreducer double product [0...25.5s]
Toff Product X	T off motoreducer double product [0...25.5s]
Double Product 2	
E.V. X	Number 1 [^] EV [0...8] 0=E.V. not coupled to this button
T E.V. d.p.	T opening E.V. [0...99.9 s]
R E.V. d.p.	Opening delay E.V. [0...25.5 s]
T Mixer 1E.V.	T Mixer coupled to E.V. [0...25.5 s]
R Mixer 1 [^] E.V.	Mixer delay coupled to E.V. [0...25.5 s]
T product X	T first box coupled to E.V. [0...99.9s]
R product X	First box delay coupled to E.V. [0...25.5s]
Ton product X	T on motoreducer double product [0...25.5s]
Toff product X	T off motoreducer double product [0...25.5s]

5.3.5 'Times and Thresholds' Menu

Pump Timeout	Pump timeout [0÷90 s]
Load Timeout	Water load timeout [5÷240 s] Load timeout linked to the Water Entry EV in DC in case of A/R distributor or to immersion pump in case of S/A distributor. Whenever errors are reset, also this timeout will be reset.
T-out motors slave X	BVM600 spiral motor timeout [0÷25.0 s]. The wording Slave X shows the number of slave linked to MASTER distributor. It is managed only by WinBianchi. In the management of the spiral distribution there is an additional internal timeout for complete distribution. This timeout is equal to the max motor timeout, i.e. 25.5 s.
Grinder timeout	Grinder timeout [0÷25.5 s]
Grinder threshold	Threshold to read grinder current [5.0÷18.0]
T. coffee preparation	Coffee preparation time [2.9÷23.0 s]. Linked to automatic grinding.
T. cleaning	Cleaning water time [0÷25.5 s]
S/T Pump Time	Advanced pump start time for train tank [0.0 – 5.0 s]
Cold cleaning	Cold cleaning management [Yes/No] For models with cool unit only. Before making a cold drink the hydraulic circuit is cooled with a cold water cleaning.
Timeout Lift x	Timeout Lift [0÷25.5s]. Time within which the lift must complete a selection.
Attempt Cabinet x [0-3]	If the cabinet times are equal to 0 this parameter will appear that allows to choose the number of failures after which the spiral goes to alarm mode. Default 1.
Extra time sector X	Additional movement in case of failed passage of the product further to a selection [0.0 ... 1.0s]. X=11 to 68 and corresponds to every spiral installed in the distributor (priority over cabinet attempts). If the parameter is set to 0, this function will not be available and the management logic will change giving the possibility of managing the cabinet attempts. If the distributor consists of 5 cabinets, it will obscure the parameter for cabinets 6-7-8. Every 0,1 s in empty conditions will correspond to approx. 12 degrees of movement of a spiral. Default value 0,3 s.
Time prel. Ev X	Programming goes from a minimum of 0.0 s to a maximum of 10.0 s and it is possible only for the actually installed electrovalves except for espresso coffee electrovalve. It consists in enabling, for the set time, the electrovalves involved in the distribution (except for the espresso coffee electrovalve) if the time passed from the last distribution of the relevant electrovalve is longer than 60s.

Below are the possible conditions:

Condition	Operation	Type of alarm
Time of mains lack rete < T Power Off	Regular	None
Time of mains lack = T Power Off	Regular	None
Time of mains lack > T Power Off	Inhibits last two cabinets	ECA - stored EJB - stored
Time of mains lack > 999	Stops machine	Out of order

If the machine remains off for more than 999 minutes, it will be necessary to reset the alarms to restart all distributor controls. Whenever a reset is carried out the time will be set to zero. After the reset the first switching off and the following switching on of the distributor will not be considered (e.g. Maintenance and/or Loading). Further to the inhibition of the cabinets signalings of unavailable selections will be generated (also remote).

The date and time will be stored every 5 minutes. This extension will ensure 9 years of duration of the location writing.

5.3.6 'Payment systems' Menu

5.3.6.0 General Parameters

Protocol Selection of Payment System (Up-Down Scroll menu)

Parallel

Credit Timeout Management of credit timeout before going to overpay [0-180s]

Multivend Enables multisale [On/Off]. If ON the credit will permanently remain on the display and bypass the set timeout. If OFF the credit timeout will be managed

Decimal point Decimal point [00000, 0000.0, 000.00, 00.000] For Parallel protocol only.

If the Validator is selected, the distributor will always be in Exact Change mode.

Executive

Immediate Change Enables distribution of the instant change if a hot selection is made [On/Off] Priority on Multivend. Displayed only if Executive Protocol.

Fixed in line 1-2 Enables message "Enter exact change" fixed on the display if the coin box cannot give change

ECS diff.

Price Timeout Price timeout (only for ECS or price holding) [2.0÷25.0 s]

Fixed in line 1-2 Enables message "Enter exact change" fixed on the display if the coin box cannot give change

Immediate Change Enables distribution of the instant change if a hot selection is made [On/Off] Priority on Multivend. Displayed only if Executive Protocol.

Price Holding

Price Timeout Price timeout (only for ECS or price holding) [2.0÷25.0 s]

Price Table (Yes/No) If NO the price table is unique and manages 50 prices (1 –50).

If YES the price table is subdivided into two tables.
First table 1 –25. Second table 26 (25+1) 50 (25+25)

MDB

Credit Timeout Management of credit timeout before going to overpay [0...180s]

Multivend Enables multisale [On/Off]. If ON the credit will permanently remain on the display and bypass the set timeout. If OFF the credit timeout will be managed

Fixed in line 1-2 Enables message "Enter exact change" fixed on the display if the coin box cannot give change

Ignore Exact Change OFF

1- Configuration MDB Coin box+ Banknote reader: if the coin box cannot give the change the banknotes will not be accepted;
2- Configuration MDB Coin box+Cash less+Banknote reader: The reader is enabled only to recharge keys.

ON:

1- Configuration MDB Coin box+Banknote reader: if the coin box cannot give the change the banknotes will be accepted;

2- Configuration MDB Coin box+Cash less+Banknote reader: The reader is enabled only to recharge keys.

Max.change Max.change than can be given by the coin box[0÷9999]

Coin changer Enables the change lever [Yes/No]

Max coin credit Max.credit accepted by the coin box [0÷65535]

Max credit on key Max.credit that can be changed on the key[0÷65535]

Ignore ExChg Ignores coin inhibitions of in 'exact change' [Yes/No]

Min Lev tube 1 X Selects minimum quantity in tube 1 [1...20]

Min Lev tube 2 X Selects minimum quantity in tube 2 [1...20]

Min Lev tube 3 X Selects minimum quantity in tube 3 [1...20]

Min Lev tube 4 X Selects minimum quantity in tube 4 [1...20]

Min Lev tube 5 X Selects minimum quantity in tube 5 [1...20]

Enab. TOKEN Enables TOKEN [On/Off]

Token Sets the value of Token 1 [000.00÷999.99]Enabled only if Enab.Token On

Token 2 Sets the value of Token 2 [000.00÷999.99] Enabled only if Enab.Token On

Token 3 Sets the value of Token 3 [000.00÷999.99] Enabled only if Enab.Token On

Change x Token Enables change if token value is > than selection [Y/N] Enabled only if Enab. Token On

Recharge Token Enables recharge of token value on key [Y/N] Enabled only if Enab.Token On

Ex.Chg. & Token Inhibits the acceptance of tokens when the machine is in Exact Change [Y/N] Enabled only if Enab.Token On

During the reset phase the payment system is inhibited.

5.3.6.1 Coins/Line

Coin 1	Associazione moneta - linea 1 [0÷65535]
...	
MCoin 16	Associazione moneta - linea 16 [0÷65535]

5.3.6.2 Banconote/Linea

Banconota 1	Coin - line 1 association [0÷65535]
...	
Banconota 16	Coin - line 16 association [0÷65535]

5.3.6.3 Banknote/Line

Banknote 1	Banknote - line 1 association [0÷65535]
...	
Banknote 16	Banknote - line 16 association [0÷65535]

5.3.6.4 Enabling coins

Coin 1	Enables coin 1 [On/Off]
...	
Coin 16	Enables coin 16 [On/Off]

5.3.7 'Price Table' Menu

If set price table No

Price 1	Price 1 [0÷65535]
...	
Price 50	Price 50 [0÷65535]

If set price table Yes

Price 1	
....	Price table 1
Price 25	

Price 25 + 1	
...	Price table 2
Price 25+25	

5.3.8 'Price-Selections' Men

All at price 1	All selections associated to price 1 [On/ Off] Except preselection buttons. The preselection button price must be associated to the relevant key.
Price Presel XX	Preselection Price from 1 to 12 [1÷50]. Only the first 12 keys can have this function.
Price select. 01	Drink price 1 [1÷50]
...	
Price select. 30	Drink price 54 [1÷50]
Price sect/col XX	Price sector /column XX [1÷50]
...	
Prezzo sect/col XX	Price sector /column XX [1÷50]
P Jug Sel 1	Price for every single jug of selection 1. Not linked to All price at 1.
...	
P Jug Sel 30	Price for every single jug of selection 30. Not linked to All price at 1.

Near the line of the price table the set price must be displayed to facilitate programming. A and B refer to BVM600 A and BVM600 B to make the Trio.

5.3.9 'Sales' Menu

Tot.collected hot	Unresettable total hot amount [0÷16777215]
Hot collect.	Resettable total hot amount [0÷16777215]
Total collected snack	Unresettable total snack amount [0÷16777215]
Total snack	Resettable total snack amount [0÷16777215]
Unresett.total coll.	Unresettable total amount [0÷16777215]
Total collect.	Resettable total amount [0÷16777215]
Discount	Total discount sum of all discounts applicable to one preparation [0÷16777215]
Overpay	tot Overpay- Amounts collected but not used [0÷16777215]
Unresett.total selections	Unresettable total select. Paid/Free/ Test [0÷16777215]
Total selections	Resettable total select. Paid/Free/Test [0÷16777215]
Paid selections	
Total selections	Unresettable total selections- PaidHot+Snack [0÷16777215]
Total selections	Resettable total select. Paid Hot+Snack [0÷16777215]
Unres.total hot selections	Unresettable total hot selections [0÷16777215]
Hot total select.	Resettable total hot selections [0÷16777215]
Select. 01	Selection counter- drink 1 [0÷65535]
...	
Select. 54	Selection counter- drink 54 [0÷65535]
Unreset.total snack	Unresettable total snack selections [0÷16777215]
Total snack	Resettable total snack selections [0÷16777215]
Selections-sect. 11	Selection counter-sector 11 [0÷65535]
...	
Selections-sect. 68	Selection counter- sector 68 [0÷65535]
Free	
Tot. Free	Unresettable total free [0÷16777215]
Tot. Free	Resettable total free [0÷16777215]
Free sel. 01	Free counter- drink 1 [0÷65535]
...	
Free sel. 54	Free counter- drink 54 [0÷65535]
Free sect. 11	Free counter- sector 11 [0÷65535]
...	
Free sect. 68	Free counter- sector 68 [0÷65535]
Jug	
Unresett.total jug	Unresettable total jug [0÷16777215]
Tot. jug	Resettable total jug [0÷16777215]
Jug sel. 01	Jug counter- drink 1 [0÷65535]
...	
Jug sel. 30	Jug counter - drink 30 [0÷65535]
Free jug	
Total free jug	Unresett. Unresett. tot. free jug [0÷16777215]
Total free jug	Resettable total free jug [0÷16777215]
Free jug sel. 01	Free jug counter- drink 1 [0÷65535]
...	
Free jug sel. 30	Free jug counter- drink 30 [0÷65535]

Jug test
 Unreset.total jug test. Unresettable total jug test [0÷16777215]
 Total jug test Resettable total jug test [0÷16777215]
 Jug test- sel. 01 Jug test counter - drink 1 [0÷65535]
 ...
 Jug test – sel.54 Jug test counter - drink 54 [0÷65535]

Test
 Unreset.total test Unresettable total test [0÷16777215]
 Total test Resettable total test [0÷16777215]
 Test sel. 01 Test counter- drink 1 [0÷65535]
 ...
 Test sel. 30 Test counter- drink 30 [0÷65535]
 Test sect. 11 Test counter- sector 11 [0÷65535]
 ...
 Test sect. 68 Test counter- sector 68 [0÷65535]

Preselections
 Tot Presel 1 Tot Preselection 1 resettable [0÷16777215]
 ...
 Tot.Presel X Tot Preselection XX resettable [0÷16777215]

Coins
 Coin 1 Coin 1 counter [0÷65535]
 ...
 Coin 16 Coin 16 counter [0÷65535]

Banknotes
 Banknote 1 Banknote 1 counter [0÷65535]
 ...
 Banknote 16 Banknote 16 counter [0÷65535]

Sales code Sales code setting [00000÷99999]
 Erase code Enter code [0000÷9999, default 0001]
 Replace code? Replace code? [Yes/No]
 Code Code setting [0000÷9999]
 Set to zero? Set sales data to zero? [Yes/No]

5.3.9.1 'System Audit'

Aut. Tub. Value of coins automatically inserted [00000÷99999]
 Man. Tub. Value of coins manually inserted [00000÷99999]
 Aut. Em. Value of coins automatically depleted [00000÷99999]
 Man. Em. Value of coins manually depleted [00000÷99999]
 Acc. CP. Value of coins loaded on key [00000÷99999]
 Add. CP. Value of coins unloaded through key [00000÷99999]

Reset Tubes
 Code Enter code [0000÷9999, default 0001]
 Replace code? Replace code? [Yes/No]
 Code Code setting [0000÷9999]
 Set to zero? Set tube data? [Yes/No]

5.3.10 'Clock' Menu

The following menus are available:

Hour/minute
 Date
 Switch on
 Cleanings
 Disinfection

5.3.10.1 'Hour/minute'

Set hour/minute Sets current hour and minute [00:00÷23:59]

5.3.10.2 'Date'

Set Date Sets current date [Mo dd/mm/yy]

5.3.11 Default data

Code Enter code [6666]. It will be a fixed code for all established by Bianchi.

Reset? Reset factory data? [Yes/No]

When the distributor is programmed in the assembly line, the std settings are duplicated and inserted in the default data table. If the configuration is reset, the same data as loaded in Bianchi Vending Spa will be obtained.

5.4 MAINTENANCE

Maintenance is performed by pressing the key 'Service'.
 In line 1 "Maintenance xxx" will be displayed, where xxx displays the boiler temperature, and in line 2 the possible detected alarms.
 Pressing twice the key Service, the stand by heating phase will be bypassed, allowing you to perform test selections even on non regimen temperatures. Pressing a key the slave boiler temperature will be displayed in scroll.
 The maintenance panel has the following functions

In the maintenance mode the keys have the following meaning:

- P1 scroll alarms
 - P2 reset alarms
 - P3 complete test
 - P4 only water test
 - P5 not used
 - P6 not used
 - P7 group rotation
 - P8 total entries display
 - P9 column rotation
 - P10 cup release
 - P11 test without sugar and spoon
 - P12 spoon release
 - P13 decoupler reset
 - P14 mdb tube filling
 - P15 mdb tube depletion
 - P16 micro switch test
 - P17 mixer test
 - P18 coffee dose unit and grinder test
-
- P1 alphanumeric keypad alarms scroll
 - P5 alphanumeric keypad alarms reset

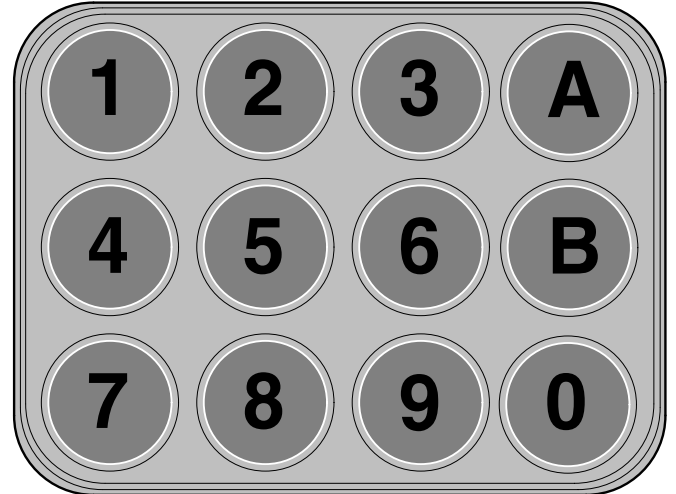

Code keyboard

In maintenance mode it is necessary to enter in sequence, via the alphanumeric keyboard, the numbers shown to obtain the desired function.

Direct selection keyboard –LEI 700

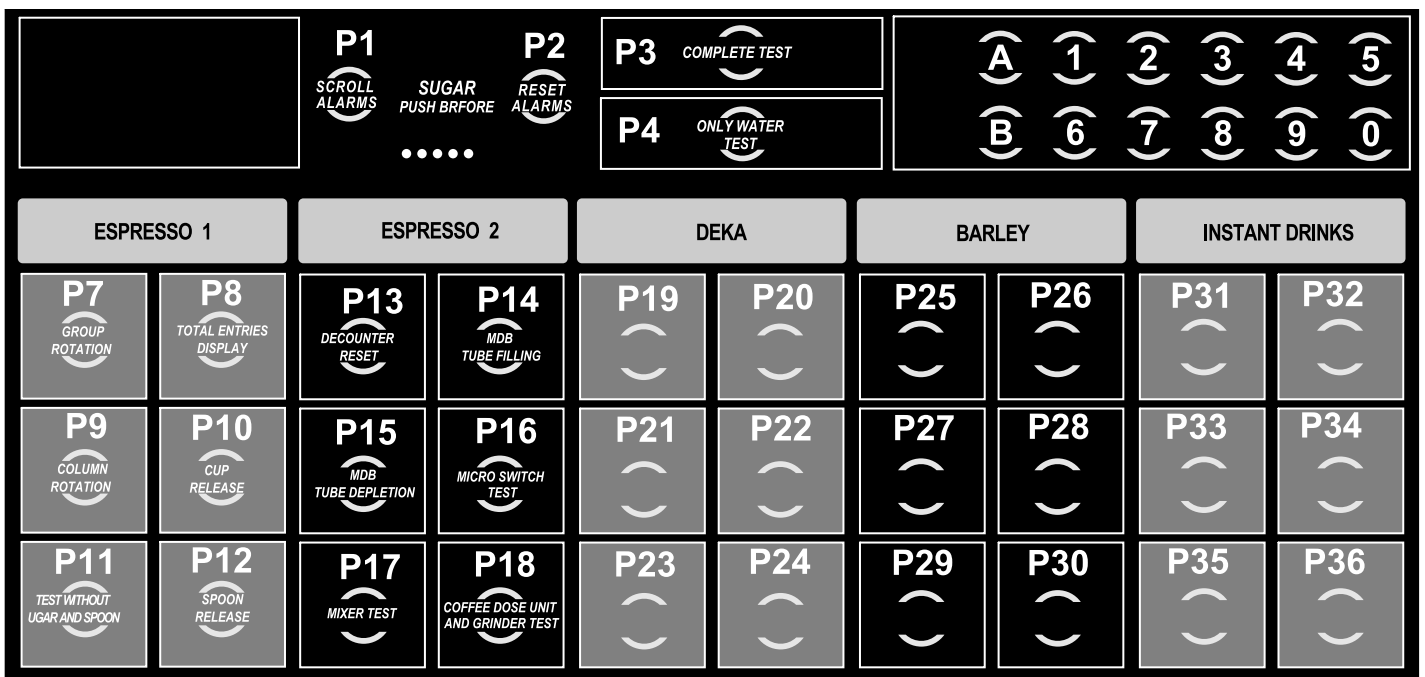

Direct selection keyboard –LEI400

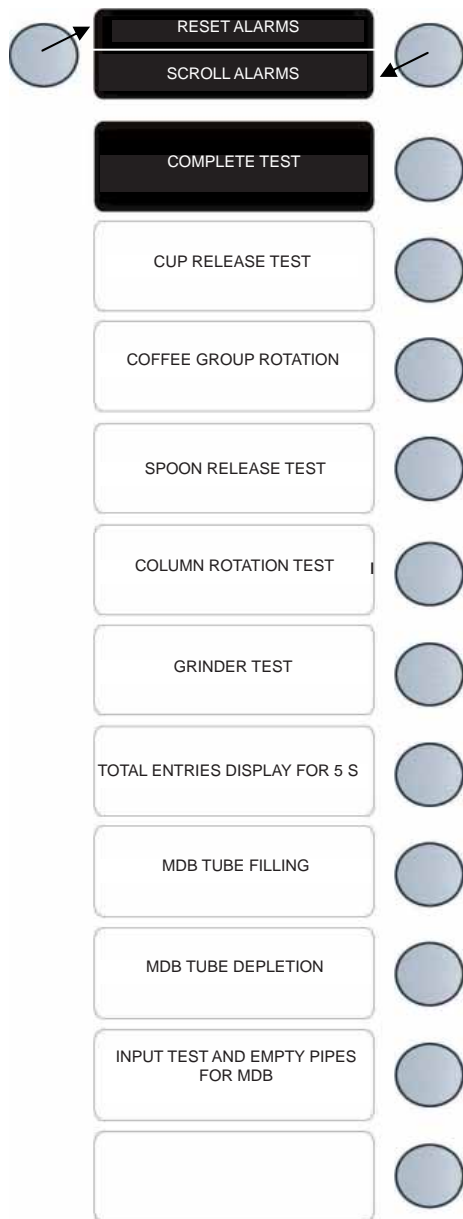

Test without sugar	Performs an option drink without sugar
Complete test	After pressing this key in line 2 the word Test will be displayed and the machine will wait for the selection; at the end of the preparation the machine exits the test mode to go back to maintenance mode.
Only water test	In line 2 the word Test will be displayed and the machine will wait for the selection The selection will be made by setting all solubles to zero, while the test of drinks with espresso coffee is complete, at the end of the preparation the machine exits the test mode to go back to maintenance mode.
Ground coffee test	By pressing this key line 2 will display Ground Test and the distributor will make a grinding and then the dispenser will be released. In this way the operator can check the grain size and the basic weight of th ground dose.
Failure reset	All alarms are set to zero and the diagnosis of the Automatic distributor is performed. Line 2 will show the Reset message for a T of 2 seconds.
Mixer test	Switches on the Mixers for 5 sec. in the following order 1,2,3,4,5,6
Group rotation	Makes a rotation of the coffee group
Alarm scrolling	Used to scroll installed alarms and signalling. In case of signalling, these are displayed in line 2 as soon as maintenance mode is accessed, in case of no signalling line 2 will be blank. Visualization is not automatically updated during the maintenance mode; to update it this key must be pressed again.
Total selections	The total unresettable selections are displayed for a T of 2 seconds, then it is possible to return to maintenance mode.
Spoon release	Releases one spoon
Column rotation	Allows column rotation
Cup	Releases cup
1° FB cleaning	1° FB piston cleaning
2° FB cleaning	2° FB piston cleaning
Decount reset	Allows to reset the decounters to the initial value. A double pressing must be made.
MDB tube filling	Filling MDB tubes
MDB tube depletion	Coin 1 (key X depletes) ... Coin 16 (key X depletes)
Micro switch test	By pressing this key we will access the micro switch test status. In this status by pressing the micro switch to be tested, the master board will provide a BEEP to confirm its operation.

6.0 MAINTENANCE AND INACTIVITY

6.1 Cleaning and Loading



 So as to guarantee the correct functioning of the distributor during time it is necessary to effect some operations periodically, some of which are indispensable for the observance of the health standard norms. These operations must be done with the distributor open and switched off. The cleaning operations must be effected before the loading of the products. In order to guarantee normal operation, the machine must be installed in areas that the environmental temperature is between a minimum of -1°C and a maximum of $+32^{\circ}\text{C}$ and humidity of not over 70%. Must not be installed in places where cleaning is done with water hoses (ex. big kitchens.).



Do not use water jets to clean the machine.

Please refer to the provisions of section III SAFETY REGULATIONS and section 4.0 INSTALLATION of this manual.

6.1.1 Recommended maintenance

  **Bianchi Vending Group spa** guarantees the proper operation of its distributor over time only with a preventive maintenance carried out in compliance with the provisions listed below:

TYPE OF INTERVENTION	No. of COUN				
	5.000	10.000	20.000	30/40.000	70/80.000
Softener regeneration (*Resins)	•				
Replacement of piston equipped with filters and gask		•			
Replacement of entire coffee group		•			
Decalcification of espresso boiler and solenoid valves				•	
Replacement of grinders					•
Decalcification of instant drink boiler and solenoid valve					•

*: if not otherwise recommended by the softener supplier.

6.1.2 Periodic cleaning by the maintenance technician

First step: disposal of the waste inside the waste bins (used cups, stirrers, paper, tissues etc). Once the waste has been disposed of it is possible to clean the surrounding area.

- elimination of the coarse dirt
- disinfecting of the flooring and walls of the area surrounding the machine up to a radius of 1 metre around the distributor
- once this is complete proceed with opening the distributor.

6.1.3 Daily cleaning recommended

The objective is that to avoid the creation of bacteria in the food zone areas.

 For all cleaning operations follow the instructions indicated in paragraph 6.3.1.

Operate as follows:

- clean all the visible parts in the dispensing area. (Fig. 6.1 e Fig. 6.2)

remove and clean carefully:

- funnels and powder chutes (Fig. 6.3-pos.1)
- canal água (2), camara miscelacao (3), ventainha de mistura-gem (4) e anel (5).

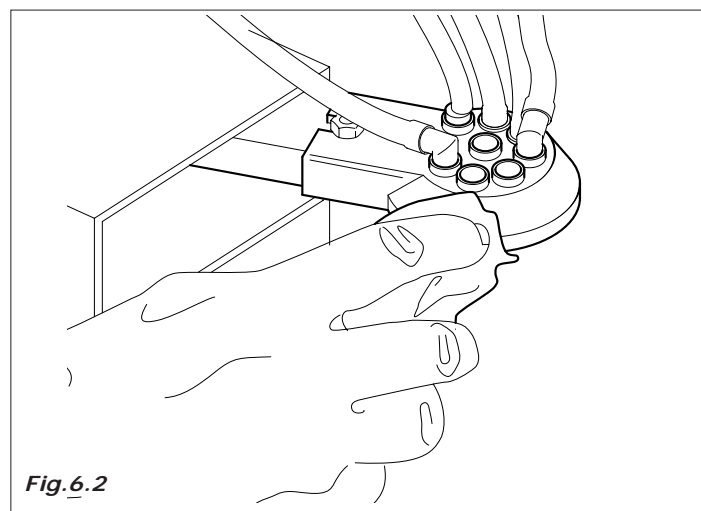

Fig. 6.2

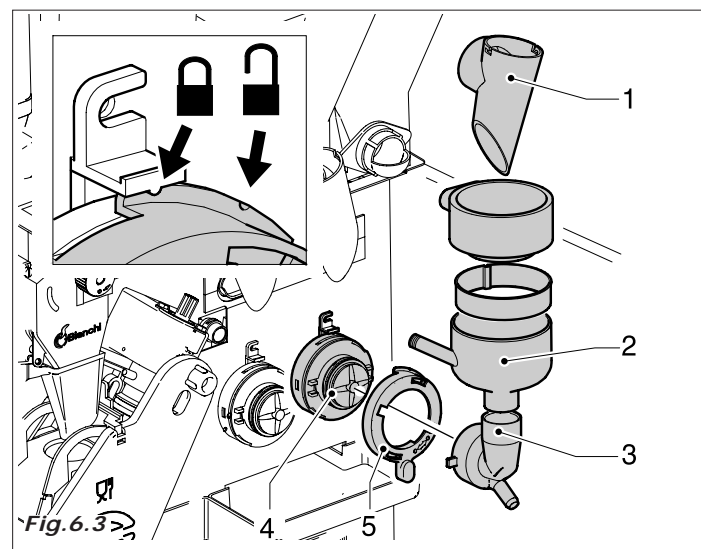

Fig. 6.3

- silicone water dispensing tubes.
- dispensing chamber (Fig. 6.4)
- coffee funnel and chute (Fig. 6.5)

Before effecting the re-assembly operations clean all the elements carefully.

- remove all coffee powder residue; the unit can be removed from its housing to make the task easier (Fig. 6.6)

6.1.4 Product loading

When necessary provide for the loading of the products and/or consumption materials of the automatic vending machine. For these operations please refer to the operations described under chapter 4.6.

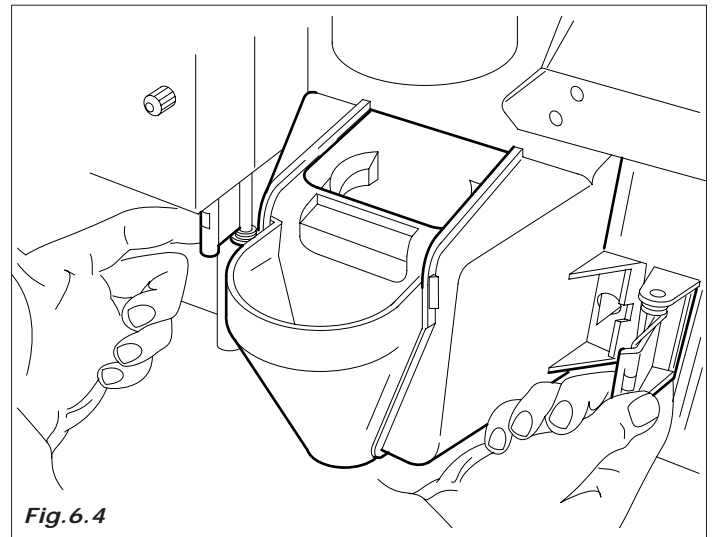
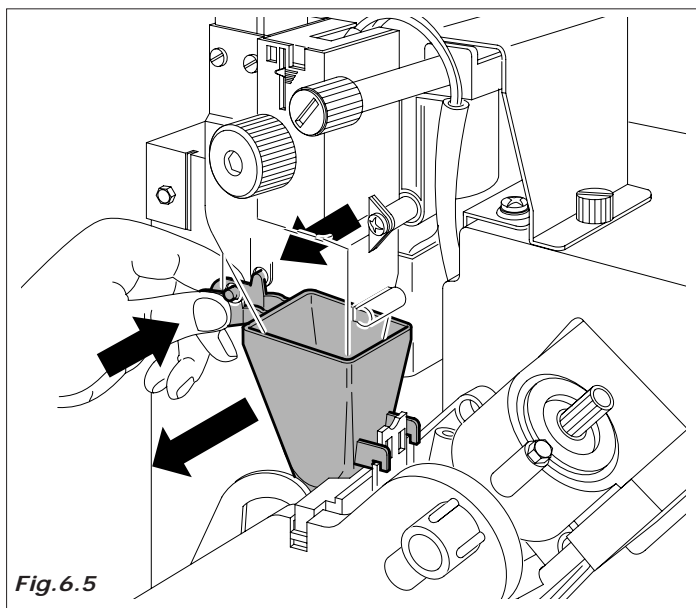

Fig. 6.4

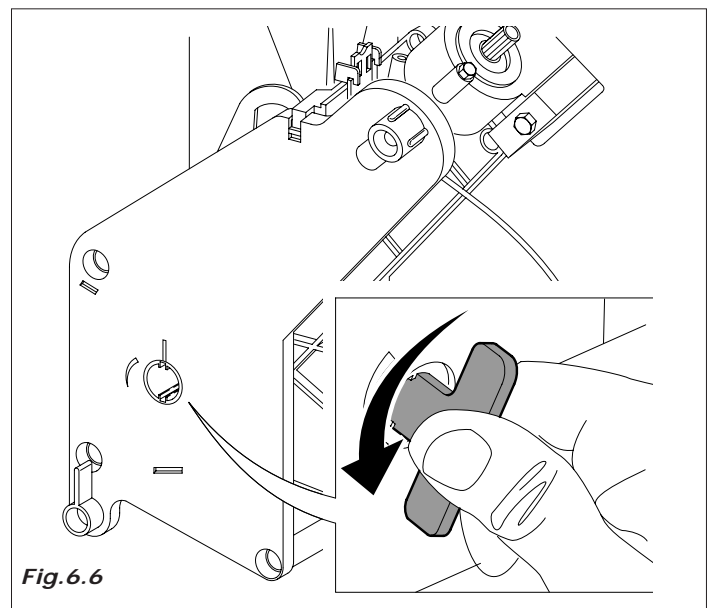

Fig. 6.6

6.2 Ordinary and Extraordinary Maintenance

The operations described in this section are purely indicative as they are tied to variable factors such as the water hardness, humidity, products used and workload, etc.



For all operations that require the disassembly of the distributors' components, make sure that the latter is switched off.

Entrust the operations mentioned here below to qualified personnel.

If the operations require that the distributor be switched on, entrust them to specially trained personnel.

For more complicated interventions, such as removing the lime build-up in the boilers a good knowledge of the equipment is necessary.

Monthly effect the debacterisation of all the parts in contact with food substances using chlorine based solutions following the operations already described under chapter 4.5.3.

COFFEE MACHINE TIMING CHECK PROCEDURE

Ensure that during the idle state, the rotating index is aligned with the stage index (see fig. 6.7)

Ensure that during the delivery stage that the rotating index is not more than 1.5 mm in advance of the delivery reference point (the rotating index must be at a delivery position of between 0 and 1.5 mm from the delivery point).

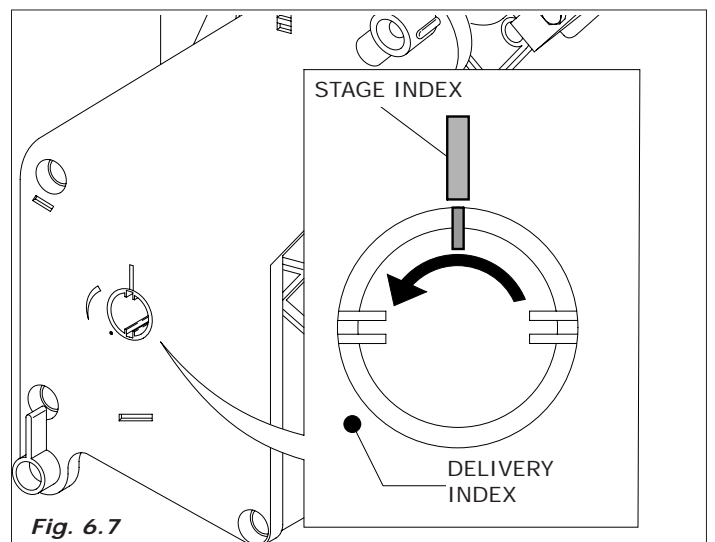

Fig. 6.7



6.3 MAINTENANCE PROCEDURES

Recommended equipment:

For those responsible for filling up and maintenance of the machine the recommended equipment is as follows:

- Tool carrier case
- Clean uniform
- Disposable gloves
- Clamp for closing the
- Roll of kitchen paper
- Wood or plastic stick
- Bottle of detergent
- Bottle of disinfectant
- "Distributor out of action" sign
- Small table for resting items (optional)

Never use:

- Sponges, scourers, cloths
- Brushes
- Screwdrivers or metallic objects.

6.3.1 Sanitization



IMPORTANT ADVICE

- Vending operators and technicians who usually get in contact with food shall pay particular attention to their personal cleaning and the cleaning of their clothes.

In particular before starting any operation on the distributor, make sure to:

- wear protection shoes or at least suitable shoes
- carefully wash your hands
- keep your hand nails short, clean and with no varnish
- keep your hair short and clean
- avoid scratching yourselves during maintenance operations
- avoid smoking and eating during work
- avoid touching hair, mouth, nose during work
- avoid wearing rings, bracelets, watches
- cover wounds (if any)
- avoid any personal strong perfume

The major food contamination passes through hands; remember to wash your hands when:

- you start working on the distributor
- after being to the toilet
- after touching your hair, blowing your nose, eating
- after touching chemical cleaning products
- after shaking hands with other people

If you use protection glove, remember to change them whenever they get in contact with polluting objects.

To ensure hygiene:

- Use disinfectants

The purpose of the disinfectants is to destroy any surface bacteria which may be present.

For cleaning:

- Use detergents and/or detersive products

The detergents act to eliminate the dirt.

Products exist on the market which are both detergents/disinfectants and are usually sold at the chemist's (chlorine-based).

For anything not mentioned in this section, refer to the HACCP regulation and in particular pay attention to the following:

- Cleaning of the premises
- Product transportation
- Machinery maintenance
- Waste disposal
- Drinking water procurement
- Personnel hygiene
- Food product characteristics
- Personnel training
- (Directive 93/43 CEE)

Important advice (ref. Directive 93/43)

- The premises where the automatic distributors are installed must be such as to prevent any accumulation of dirt, any contact with toxic materials, and the formation of condensate or mould on the surfaces of the machine.
- It is also important that the premises where the distributor is installed can guarantee a correct hygienic procedure, also preventing any cross contamination, during the operations, between food, equipment, materials, water, air recirculation or personnel interventions and excluding any external contamination agent such as insects or other harmful animals.
- Make sure that the water system complies with EEC Directive 80/778 regarding the quality of water for human consumption.
- Ensure a correct mechanical or natural aeration, avoiding any mechanical air flow from a contaminated area to a cleaned area.

The cleaning operations may be undertaken at the site of installation of the automatic distributor

Example of a recommended cleaning procedure of a hot drink automatic distributor:

The person responsible for machine hygiene, before opening the distributor must check the cleanliness of the surrounding environment and put up a sign to tell any potential consumers that:

- the machine is "out of use as maintenance is in progress"
- it is important that the person responsible for cleaning never has to interrupt his work in order to operate the machine.
- For internal cleaning use clean cloths, better if disposable.
- It is indispensable to avoid any contact between the products used for the generic cleaning of the distributor and the products to clean the parts in contact with food.
- During cleaning operations, pay attention not to transfer germs from dirty areas to already cleaned areas.

A) Use clean gloves.

B) Use hot water not taken from toilets.

C) Pay special care to clean the parts in contact with food

- Carefully remove any residual dirt before proceeding to use disinfectants.
- Carefully avoid any contact of food with dirty surfaces.
- During the cleaning operations carefully follow the instructions on the packages of chemical detergents. Absolutely avoid any contact of food with detergents.
- Make sure that your cleaning equipment is perfectly efficient.

D) At the end of the cleaning operations, place the water collecting bags in appropriate areas far from the automatic distributor areas.

The following table summarizes the recommended behaviour to reduce the risk of bacteria proliferation and contamination inside the distributor to the minimum.

TYPE OF INTERVENTION	TIME / No. of COUN		
	EVERY DAY	EVERY WEEK	20000 COUN OR MAX EVERY MONTH
Remove and wash all visible parts in the delivery area with sanitizing liquid.	•		
Empty the liquid ground collecting buckets and clean them with sanitizing liquid.	•		
Empty the coffee ground collecting tank and wash it with sanitizing liquid	•		
Remove all containers and clean with a wet cloth all container supporting parts, as well as the bottom and the outside of the distributor, in particular the delivery area; then proceed to sanitization.		•	
* Sanitization kits including plastic parts for the passage of pulverized or liquid product (cups, pipes, delivery flange, nozzles,...). For any further information, please contact directly our offices.			•
* Bianchi Vending Group has prepared specific kits expressly designed for every distributor mode			

6.4 Regulations

6.4.1 Dosage and grinding regulations

- Coffee temperature in the cup between 70 ° and 80 °
- Temperature of soup products in the cup between 70°C and 80 °C.
- Grammage of coffee powder between 6 and 8 grams.
- grams of instant powder products according to what is indicated on the specific tables.

In order to obtain the best results with the product used we advise to check:

- **Ground coffee gram weighting:** vary the quantity using the knob positioned on the measuring device (Fig.6.8).

Each notch of the regulation knob corresponds to a value of 0.05 grams.

By turning in a clockwise sense the amount decreases.

By turning in an anti-clockwise sense the amount increases.

The variation in the product can be controlled by means of the reference notches on the body of the measuring unit (see figure 6.8)

Coffee pellets must be have a compact consistency and be slightly damp.

- **Adjustment of the grade of manual grinding.**

Turn the screw (fig.6.9) to obtain the desired results.

Turn clockwise for fine grinding, turn anti-clockwise for coarser grinding.

After regulation, three product regulations must be carried out in order to assess the efficiency of the regulation, the finer the granules the greater the time required for product delivery.

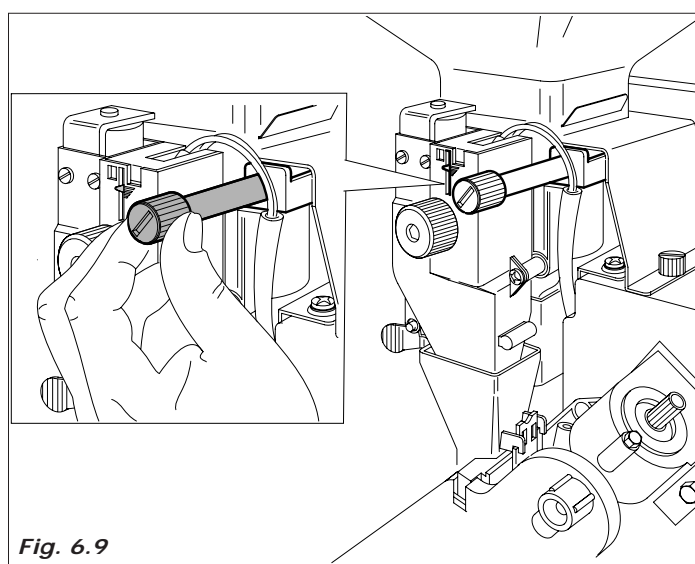
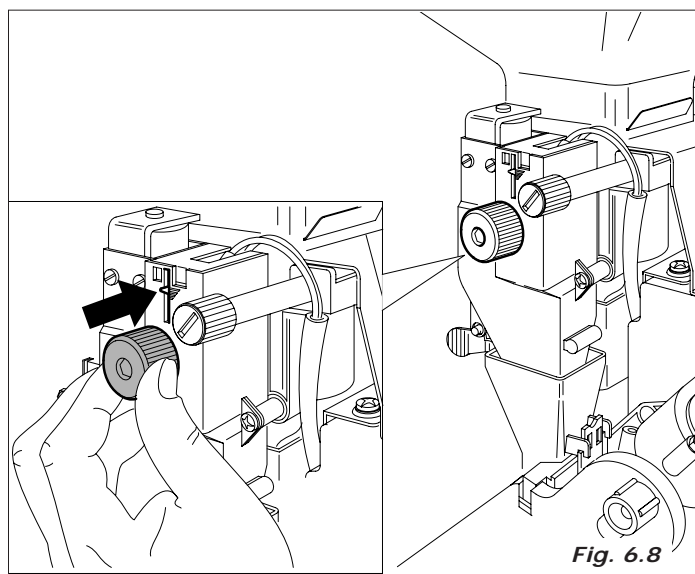

- Automatic adjustment of grinding (Fig.6.10)

- It allows in the espresso versions to keep grinding steady, irrespective of the percentage of moisture, temperature and wear of blades.
- The first adjustment is performed with the device disconnected
- Performing the dose adjustment manually (6-7g)
- Performing the grinding adjustment manually
- Reckoning the supply time in seconds (std 18s)
- Reconnecting the device
- Setting the measured supply time, in programming
- Out of 5 espresso coffee, this parameter test will be automatically performed. The valid readings correspond with the third / fourth coffee: The first two will be ignored since they are the results of the previous adjustments, the fifth will be adjusting tests

6.4.2 Regulation of the instant solenoid water delivery valves

In the case of soluble products you can regulate the quantity of water and the powder dosage electronically by varying the standard parameter, according to the procedure indicated in chapter 5.0 SOFTWARE INSTRUCTIONS.

ATTENTION: Re-adjust water rate by acting on the soup valve adjusting screws means to compromise and alter the quantity of water supplied in cup and therefore its dose.

To access the electrovalve placed in the instant boiler, remove panel (1) by loosening the two screws (2) shown in figure 6.12

- To obtain a good rinsing of cups possibly act on the rate screw and then check that doses are reliable (Fig. 6.11).

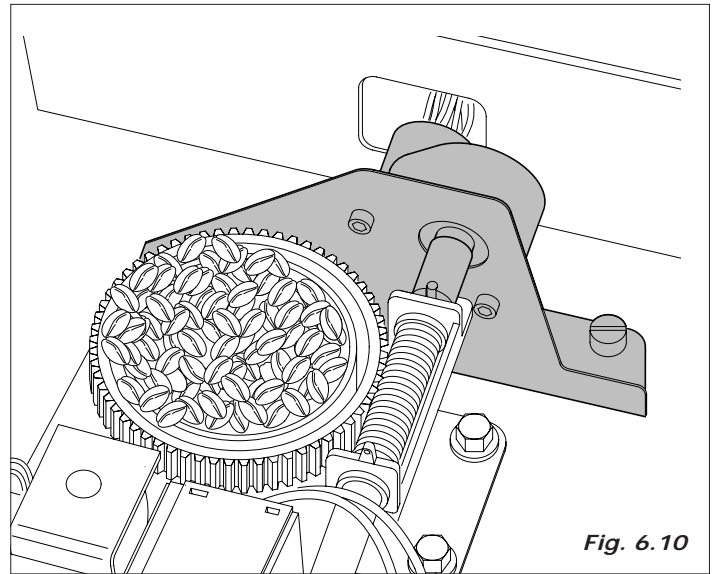

Fig. 6.10

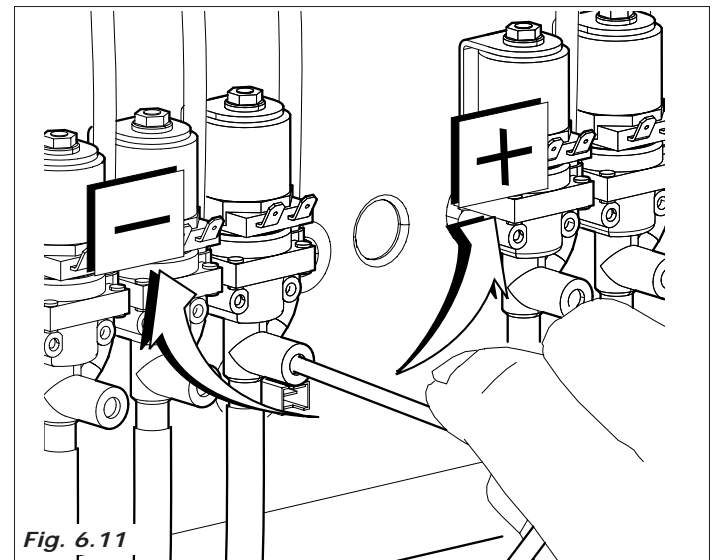

Fig. 6.11

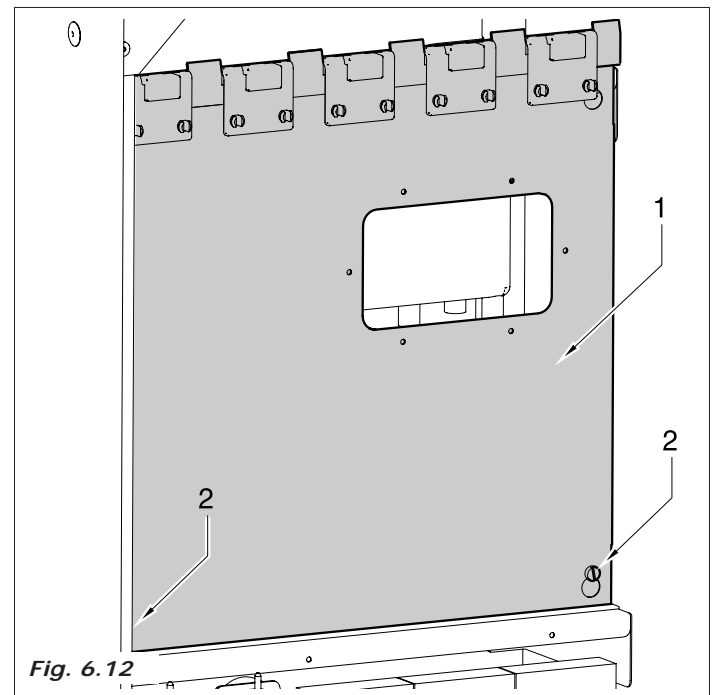

Fig. 6.12

6.4.3 Access to internal parts

To access the internal parts of the automatic distributor (pumps, espresso coffee boiler, electrovalves, electrical connections, etc.):

- Rotate the sugar dispensing group towards outside (fig.6.13).
- Then act on the two handles shown in fig. 6.14, remove the panel and support it until completely taken out (fig.6.15).

After carrying out maintenance operations, if required, lift the complete panel until it is correctly installed in vertical position, then put again the sugar dispensing group in work position by rotating it rightwards.

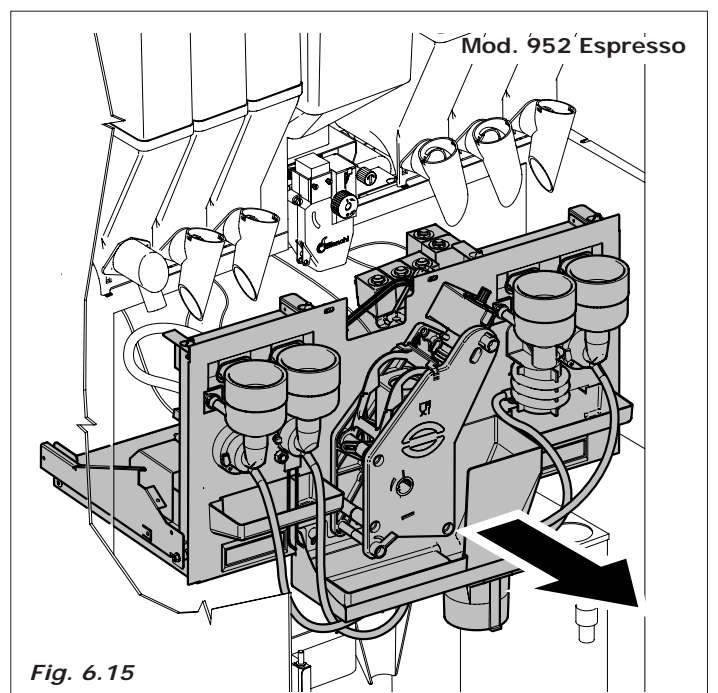
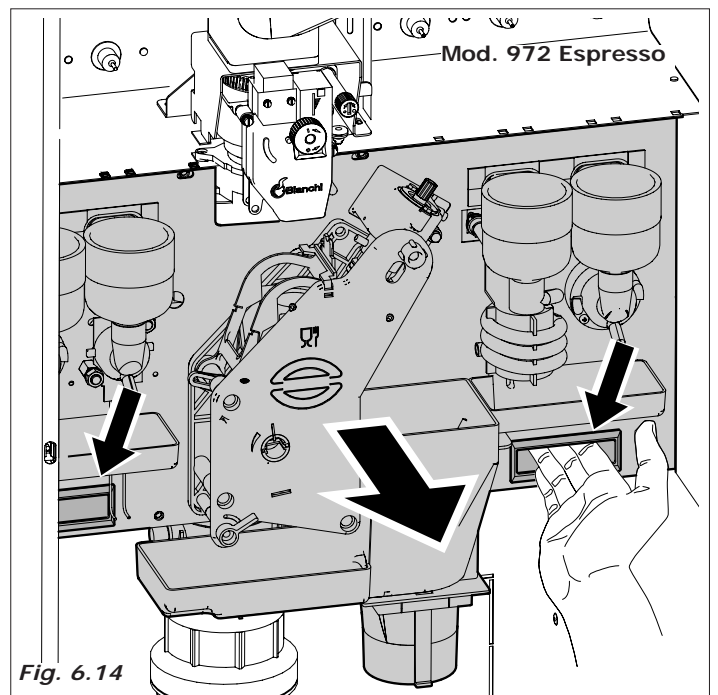
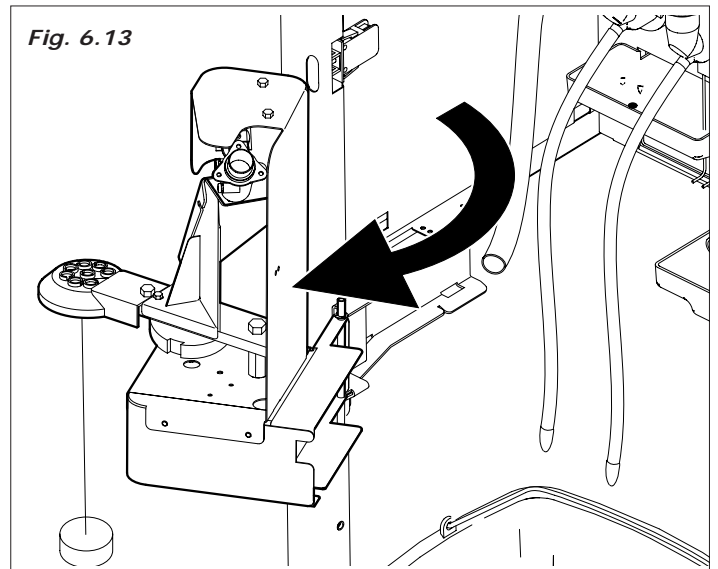

6.5 BRITA decalcificator filter

It performs water decarbonization, reduction of organic impurities (such as free chlorine, its compounds and pesticides).

They remove the temporary water hardness, and some heavy metals such as lead and copper.

They neutralize build up of bacteria through active carbon treatment on Silver base.

The filtering compound of the Brita filter AquaQuell 06-B

BRITA AquaQuell filtering systems (AquaQuell 33,1,2,3) contain ionic-exchange resins and activated granular carbon with the purpose of optimizing drinkable water.

The cationic-exchange resin (IER) is an artificial polymer with acrylic base. Groups are linked to the polymeric chains in their H⁺ form.

In the whole exchange process, calcium cations, magnesium, copper and lead are exchanged with protons.

Since IER is a weakly acid resin, only the temporary hardness is removed (The grade of acidity is given by the H⁺ concentration). The granular active carbon (GAC) is produced by the coconut shells which are charred and activated in oven.

The activation process gives an exchange surface whose GAC can, by alloying organic impurities to it such as disinfectants, chlorine and pesticides such as lindane and atrazine, etc.

Water hardness detection systems

There are various systems to check water hardness level, from immersion stripes sensitive to calcium hydrogenate dissolved in water, to ortolidina kit which can make water colour change in presence of given percentages of Ca and Mg dissolved in it.

Through the immersion strips the darker colour shows a lower hardness of water, the lighter colour a higher hardness. (see diagram)

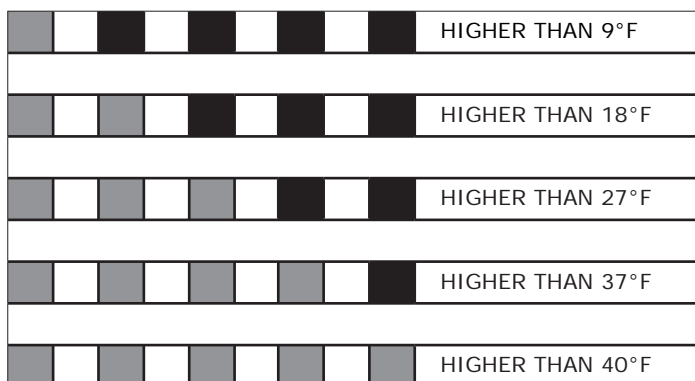

Set BRITA filter duration through the kit supplied with the decalcificator. Then, enter the data in the programming software so that, after a number of selections, the maintenance operator is warned.

Water hardness °F	Capacity lt	No. of supplies		
		130 cc.	150 cc.	180 cc.
10,5	700	5300	4600	3800
4,5	520	4000	3400	2800
18,0	420	3200	2800	2300
21,5	350	2600	2300	1900
25,0	300	2300	2000	1600
28,5	260	2000	1700	1400
32,0	240	1800	1600	1300



6.6 Resin regeneration of the water softner (Optional)

The regeneration of the resins must be executed according to the water of mains supply to which the distributor is connected. As reference the table indicated here below can be used:

Water hardness ° french	Number of selections	
	60cc	130cc
10	25000	12500
20	12500	6000
30	9510	4500
40	6500	3000
50	5000	2500

So as to verify the degree of hardness of the water and consequently the time and type of interventions, specific kits available on the market can be used.

The operation can be effected on the distributor as follows:

- switch off the machine.
- turn the lower faucet being careful to put the relative hose in a bucket or better in a drain (Fig. 6.20).
- remove the cover and introduce 1,5 kg of normal cooking salt (Fig. 6.21)
- replace the cover.
- switch on the machine and let the water pour out until it is no longer salty (Fig. 6.22).
- switch off the machine and close the faucet.

The time necessary for this operation is about 30/45 minutes.

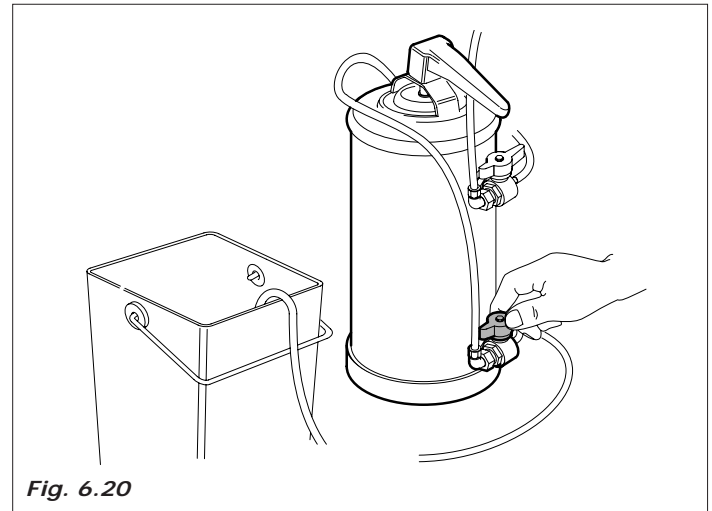

Fig. 6.20



Fig. 6.21

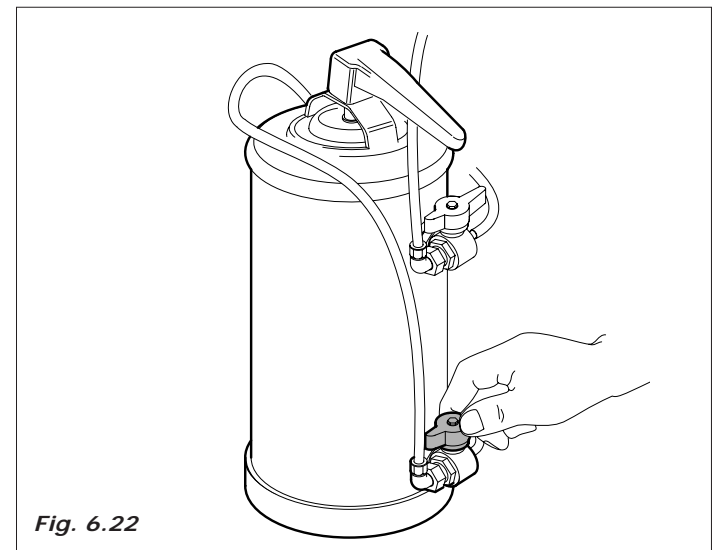

Fig. 6.22



6.8 Inactivity

If the automatic vending machine remains inactive for a long time it is necessary to perform some prevention operations:

- disconnect the machine electrically and hydraulically.
- empty completely the instant boiler and the floater reservoir removing the plug located on the hose along the drain chute (Fig. 6.25).
- Put the plug back in once the draining has been done.
- unload all the product from the containers
- perform a thorough cleaning of all the parts in contact with food substances according to what has already been described.
- empty the liquid waste bin carefully
- eliminate the spent grounds bag
- clean with a cloth all the internal and external surfaces of the machine.
- protect the outside of the machine with a plastic film wrapping or bag (fig. 6.26)
- stock in a dry and protected place where the temperature is not less than 1° C.

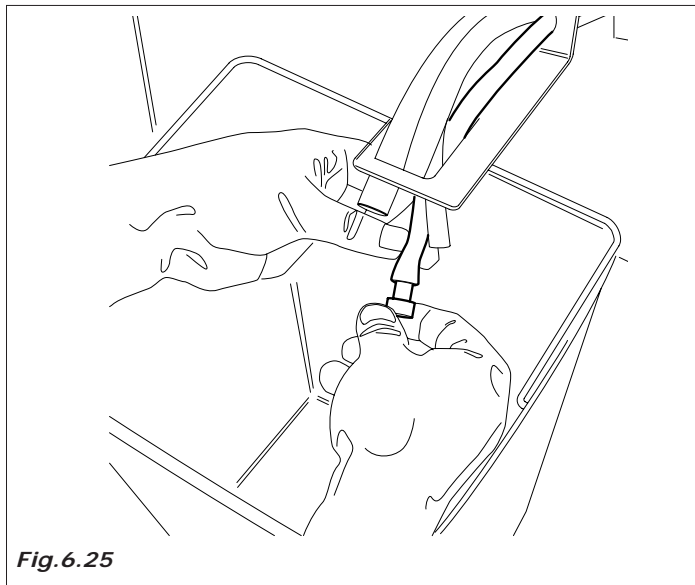

Fig.6.25

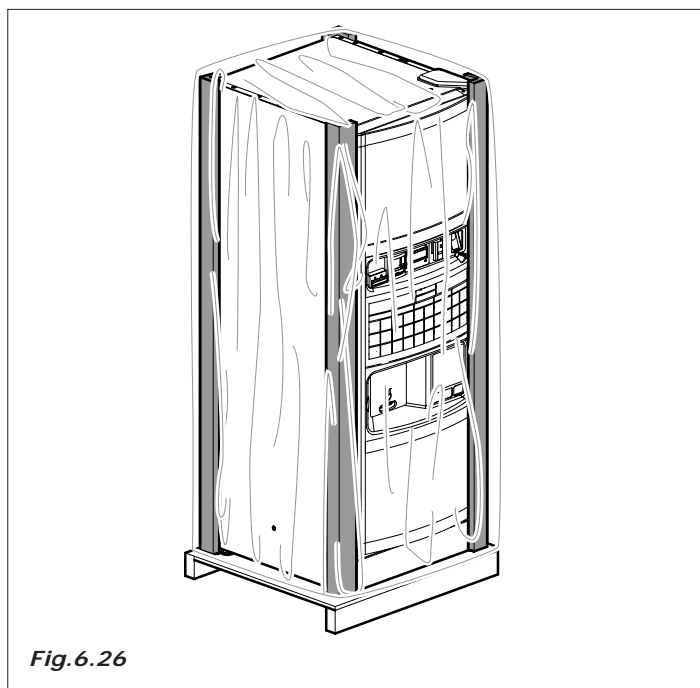

Fig.6.26

7.0 DISMANTLEMENT

Proceed with the emptying of the products and of the water as described in the previous paragraph.

For the dismantlement we advise to disassemble the machine dividing the parts according to their composition (plastic, metal etc.).

Subsequently entrust to specialised companies the parts divided in this manner.

Attention! Check that the machine disposal is performed with respect of environmental rules and according to the regulations in force

8.0 ALARMS

When an alarm occurs, it usually switches off all outputs and blocks any dispensing under way. All alarms can be eliminated, further to removing the cause, by accessing Maintenance mode and pressing Reset button. WinBianchi must include the possibility of making an alarm blocking.

8.1 BLOCKING ALARMS SHOWN ON DISPLAY

Riga 1: Alarm

Riga 2: Out of order

It occurs when a blocking error is found. The reset operation will automatically reset and re-check the occurred alarms. The alarms that generate this signal are:

Serial communication problems with Executive or MDB coin box. It occurs in case of communication error between board and coin box or the coin box itself is not found.

- Executive: a 60 sec.delay is expected from the moment the coin box is not found until the alarm starts.

- MDB: the delay is equal to 10 seconds upon start-up.

- Scale factor: This alarm is active only if the Executive coin box is enabled (not in Price Holding mode). It occurs if the division between of the programmed prices and the basic coin received by the coin box exceeds the value of 250. This alarm is self-restoring.

- Slave boards linked to the Master board in alarm conditions. Therefore no dispensing is possible.

8.2 ALARMS SHOWN IN MAINTENANCE MODE

In maintenance mode both alarms and signallings will be displayed. Signallings are a special type of alarm that does not interrupt the regular operation of the machine. Both alarms and signallings are subdivided into stored and not stored. Stored alarms and signallings persist even when the board is switched off and switched on again.

ALARMS	DESCRIPTION	TYPE OF INTERVENTION
8.2.1 Stored alarms		
ECM EEprom error	It occurs if an error is found in EEprom. By carrying out the reset operation also the factory data will be recharged in the eeprom (only if this alarm is installed).	Installer
EBI Translator	It occurs if the 10 sec timeout lapses during the movement of the spout translator	Installer
8.2.2 Non stored alarms		
EAJ Scale factor	This alarm is active only if the Executive coin box is enabled (not in Price Holding mode). It occurs if the division between one of the programmed prices and the basic coin received by the coin box exceeds the value of 250. This alarm is self-restoring.	Installer
ECE Out of order	It occurs if the communication between board and master interrupts.	Installer
EBA Cup	It occurs in one of the following two cases: 1. The 90 sec timeout for cup column rotation lapses. 2. The 10 sec timeout for cup release lapses.	Installer
EDP water level	It occurs 2 seconds after the water empty micro is detected. It switches off the resistance and re-initializes the timeout for E12 and E13.	Installer
EDM NTC X Slave Y	It occurs if the temperature probe goes to short-circuit or the circuit is open. The resistance will be switched off if NTC is in short circuit or open. Upon start up a 30 sec delay is expected prior to alarm check. NTC 1 – Related to power board NTC 2 – Related to expansion 1Slave Y specifies the machine to which it belongs. If the probe is in short circuit the maintenance mode will show a value equal to 0. If the probe is an infinite resistance open circuit the maintenance mode will show a temperature value equal to 150.	Installer

ALARMS	DESCRIPTION	TYPE OF INTERVENTION
EH1A NTC Cold	It occurs if the temperature probe of the cool unit goes to short circuit or the circuit is open. The resistance will be switched off if NTC is in short circuit or open. Upon start up a 30 sec delay is expected prior to alarm check.	Installer
EC1C Tcoffee<60°C	Referred to boiler 1. It occurs if upon reset the set temperature minus 15°C is not reached in 15 minutes or if during the regular operation the temperature remains below 60° for 15 minutes. Applicable to single boiler or for coffee boiler if the double boiler is enabled.	Installer
EC2C Tinstant<60°C	Referred to boiler 2. It occurs only if the double boiler is enabled and if upon reset the set temperature minus 15°C is not reached in 15 minutes or if during the regular operation the temperature remains below 60° for 15 minutes.	Installer
EDF Sugar	It occurs if the 10 s timeout lapses during the sugar conveyor movement.	Installer
EGN Too full	It occurs 2 sec. after the too full condition of the liquid collecting tank micro is found.	Installer
ECK No Expansion	It occurs if components managed by any expansion are enabled.	Installer
8.2.3 Stored signalings		
EDT Grinder X	It occurs if the programmed grinder timeout lapses. The display will show the "Without coffee" message. The amount is re-credited only in case of instant grinding. X=1 or 2	Installer
EEK Group	It occurs if the programmed coffee group timeout lapses. The display will show the "Without coffee" message. The amount is re-credited.	Installer
EEJ No Group	It occurs if the group presence micro is NA.	Installer
EFN ESP Pump	It occurs during the coffee water dispensing if at least 10 cc are not provided in the programmed pump timeout. The display will show the "Without coffee" message. The amount is re-credited. The boiler resistance will be switched off until the error is reset.	Installer
EFN INSTANT pump	It occurs during the water dispensing of instant products or hot water if at least half dose is not provided in the programmed pump timeout. The display will show the "Espresso only" message. The amount is re-credited if hot water was not being dispensed. The boiler resistance will be switched off until the error is reset.	Installer
EDU Dose vol 1	It occurs if after the coffee release phase the dose micro remains pressed. The display will show the "Without coffee 1" message. The amount is re-credited.	Installer
EDU Dose vol 2	It occurs if after the coffee release phase the dose micro remains pressed. The display will show the "Without coffee 2" message. The amount is re-credited.	Installer
Water empty	For machine with cool unit only. It occurs in one of the following two cases: 1. Water is not at Min Lev (with approx. 2 sec. delay). 2. The 4 min timeout for the water loading ev lapses. The display will show "Cold drinks only" message.	

ALARMS	DESCRIPTION	TYPE OF INTERVENTION
EDF Spoons	It occurs if the 10" spoon timeout lapses. With this signalling on, no spoon will be dispensed.	Installer
ELC Capacity	Dispensing of instant products or hot water: it occurs if a quantity of water between 50% and 70% of the programmed dose is dispensed. The display will show the character '*' as last character. This signalling will prevail on the decou- nter signalings (the eight signalings below)	Installer
Air pump	It occurs if during the check at the end of the dispensing from the Fresh Brew group the compressor cannot reach the pressure of 0.3 bar in 3 seconds for the circuit. The display will show the "Instant products only" message.	
EFB Cleaning filter	It occurs if the value of the cleaning filter decou- nter is equal to zero.	Maintenance operator
EDZ Grinding blades	It occurs if the value of the coffee grinding blade decou- nter is equal to zero.	Maintenance operator
EEC FB 1 filter	It occurs if the value of the FB 1 filter decou- nter is equal to zero.	Maintenance operator
EEC FB 2 filter	It occurs if the value of the FB 2 filter decou- nter is equal to zero.	Maintenance operator
EEC Esp Filter	It occurs if the value of the coffee filter decou- nter is equal to zero.	Maintenance operator
EFI Decount EV	It occurs if the value of the EV decou- nter is equal to zero.	Maintenance operator
EEL Gaskets	It occurs if the value of the coffee gasket de- cou-nter is equal to zero.	Maintenance operator
EDO Boiler 1	It occurs if the value of the boiler 1 decou- nter is equal to zero.	Maintenance operator
EDO Boiler 2	It occurs if the value of the boiler 2 decou- nter is equal to zero.	Maintenance operator
OAR HACCP	It occurs if the value of the HACCP decou- nter is equal to zero.	Maintenance operator
EDJ decount PX	It occurs if the X powder decou- nter is 000000s.	Maintenance operator
EDJ decount Gr	It occurs if the bean decou- nter is 000000s.	Maintenance operator
ECQ Driver OxxPxx	It occurs when a failure is found on output OUT XX (Oxx) on pin XX (Pxx). In case of intervention of OMNIFet overcurrent protection, Gate voltage must be read after 50 ms.	Installer

POS. COMPONENTI

- A Interr. generale di sicurezza
- B Fusibili T0A
- C Tiro controllo temp. gruppo caffè
- D Tiro controllo temp. cialdina solubili
- E Tiro controllo temp. cialdina solubili
- F Proflettore termico cialdina espresso a riarmo
- G Proflettore termico cialdina espresso a riarmo
- H Proflettore termico automatico cialdina esp.
- 1 Filtratore di flusso
- 2 Micro fine corsa sgancio bicchiere
- 3 Micro fine corsa sgancio bicchieri
- 4 Micro centratura torre bicchieri
- 5 Micro dosatore caffè
- 6 Micro fine corsa gruppo caffè
- 7 Micro presenza gruppo
- 8 Micro vuoto acqua vaschetta
- 9 Micro fine corsa supporto ugelli/traslatore
- 10 Micro sicurezza traslatore (solo BMW920)
- 11 Micro fine corsa palette(x BMW930 e BMW970)
- 12 Micro sicurezza colonna (solo BMW920)
- 13 Micro sicurezza colonna (solo BMW920)
- 14 Micro fine corsa convogliatore zucchero

COLLEMANI RESERVOIR ONLINE

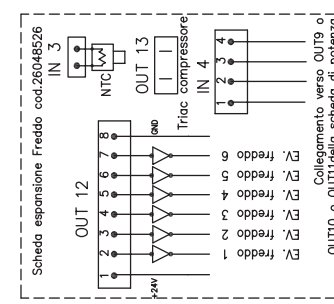
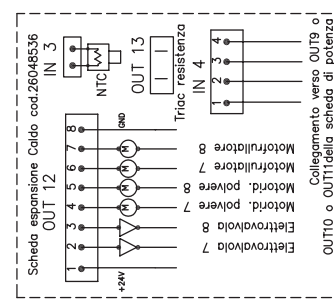
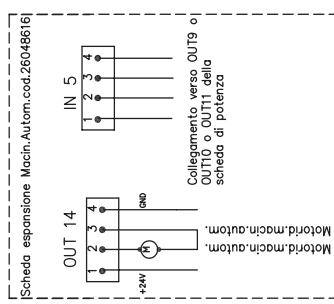
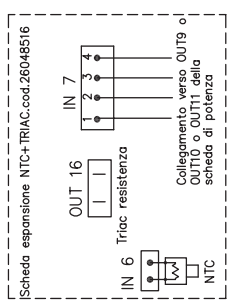
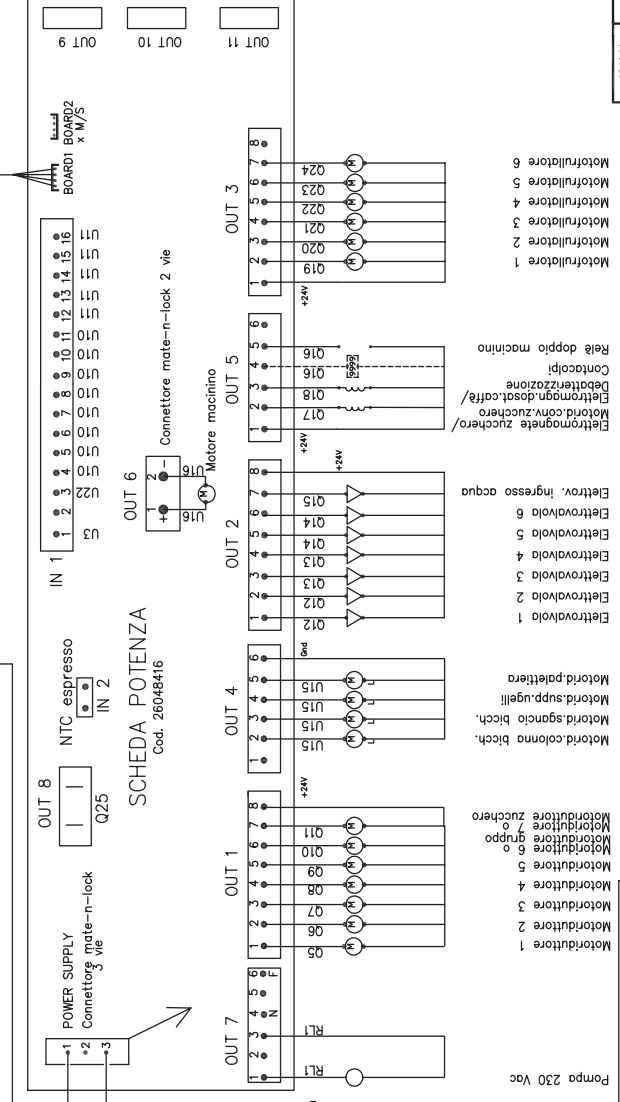
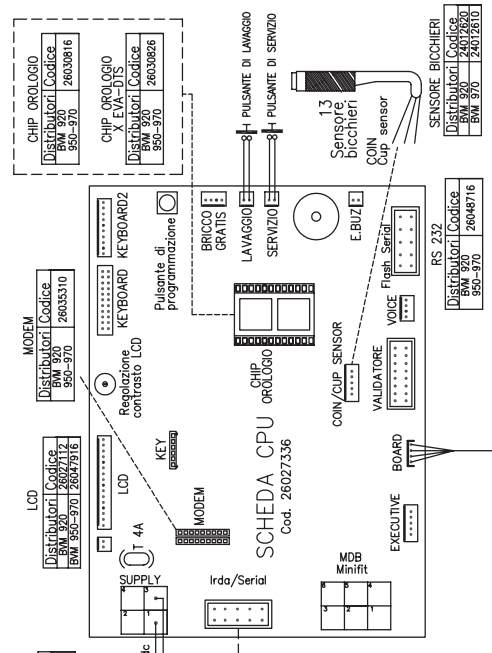
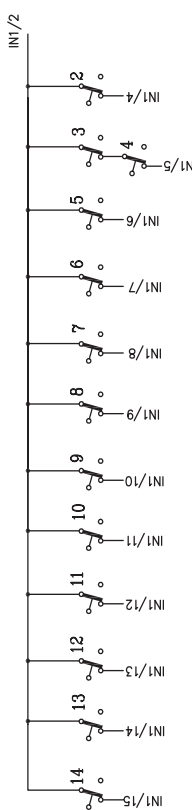
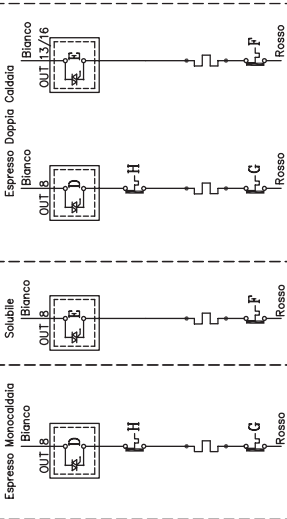



WARRANTY CLAIM

Dear Customer, The hereby form is a formal warranty claim to be sent via fax or e-mail as specified below. Please, to describe the matter occurred in the dedicated box. Beware, the BVG, could ask to return the faulty component back for quality inspection purposes. On top of that, to verify the right claiming

Warranty policy available in the Use & Maintenance manual attached to machines and on the: www.bianchindustry.com

To be sent **FAX: +39 035 883304** or **e-mail: customer care@bianchivending.com**

Model:		Serial number	
Sender <i>(company title)</i>		Customer tel No. <i>(eventual call back by the BVG)</i>	
Date		Sender E-mail/ Fax N° <i>(to confirm the warranty being activated)</i>	

MATTER OCCURED

PARTS REQUIRED

	Code	Qty
Missing parts		
Wiring/cable		
Electronics		
Power supply		
Keypad		
Hydraulic circuit		
Pump		
Electrovalve		
Motor/Electromagnet		
Microswitch		
Coffee Group		
Grinder/doser		
Cup Dispenser		
Stirrer Dispenser		
Refrigerator group		
Water filter		
Other		

Satisfaction note

(write eventual notes about product and/or service provided by the BVG. This to improve and better satisfy Your needs in the future)





FIRST INSTALLATION FORM

WARRANTY ACTIVATION

Dear Customer, The hereby form is a necessary feed-back for the Bianchi Vending Group S.p.A. Considered this form as formal report of first installation, the BVG, kindly, asks you to fill this form in, once the process of first installation of the unit has been performed and to return it back to us. Please send it via FAX or e-mail as specified below. Should anything go wrong during the first installation process, please, specify the matter occurred with relative brief description of the fact in the dedicated box then send this form to the same fax n° or e-mail address as below. Bianchi Vending Group S.p.A. will activate the 1 (one) year warranty, starting from the moment the hereby form is received correctly filled in all voices. Therefore, in addition to what said, in case the hereby form is not returned to the BVG, automatically the company will start the warranty from the date of sale of the unit.

Warranty policy available in the Use & Maintenance manual attached to machines and on the: www.bianchiindustry.com

To be sent **FAX: +39 035 883304 or e-mail: customercare@bianchivending.com**

Model:		Serial Number	
Sender:		Sender tel. N°	
<i>(company title)</i>		(eventual call back by the BVG)	
Installation Date		Sender E-mail/ Fax N° (to confirm the warranty being activated)	

MATTER DURING THE FIRST INSTALLATION?	<input type="checkbox"/> YES	<input type="checkbox"/> NO
--	------------------------------	-----------------------------

IF YES, WRITE HERE A DESCRIPTION

MATTER DURING FIRST INSTALLATION, SPECIFY PARTS REQUIRED

	Code	Qty
Missing parts		
Wiring/cable		
Electronics		
Power supply		
Keypad		
Hydraulic circuit		
Pump		
Electrovalve		
Motor/electromagnet		
Microswitch		
Coffee Group		
Grinder / doser		
Cup dispenser		
Stirrer Dispenser		
Refrigerator group		
Water filter		
Other		

Satisfaction note

(write eventual notes about product and/or service provided by the BVG. This to improve and better satisfy Your needs in the future)





BIANCHI VENDING GROUP s.p.A.
Corso Africa 9 - 24040 Località Zingonia, Verdellino (BG) - ITALIA
tel. +39.035.4502111- fax +39.035.883.304