

Living up to Life

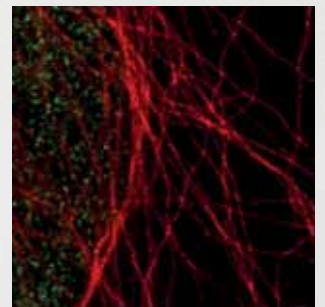

Leica TCS SP8

Looking Forward to Your Discoveries

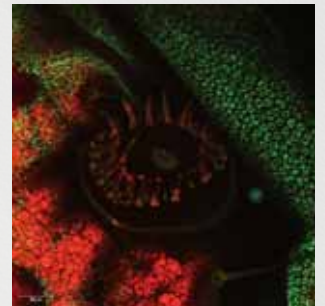
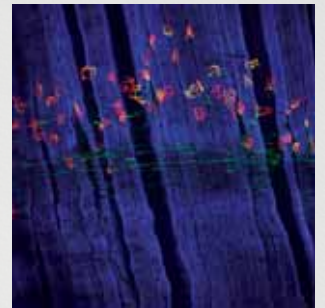
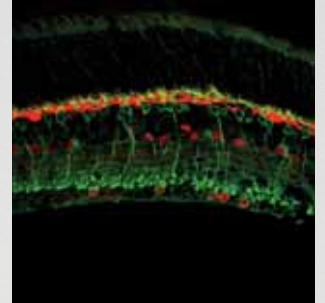

LIFE SCIENCE RESEARCH DIVISION

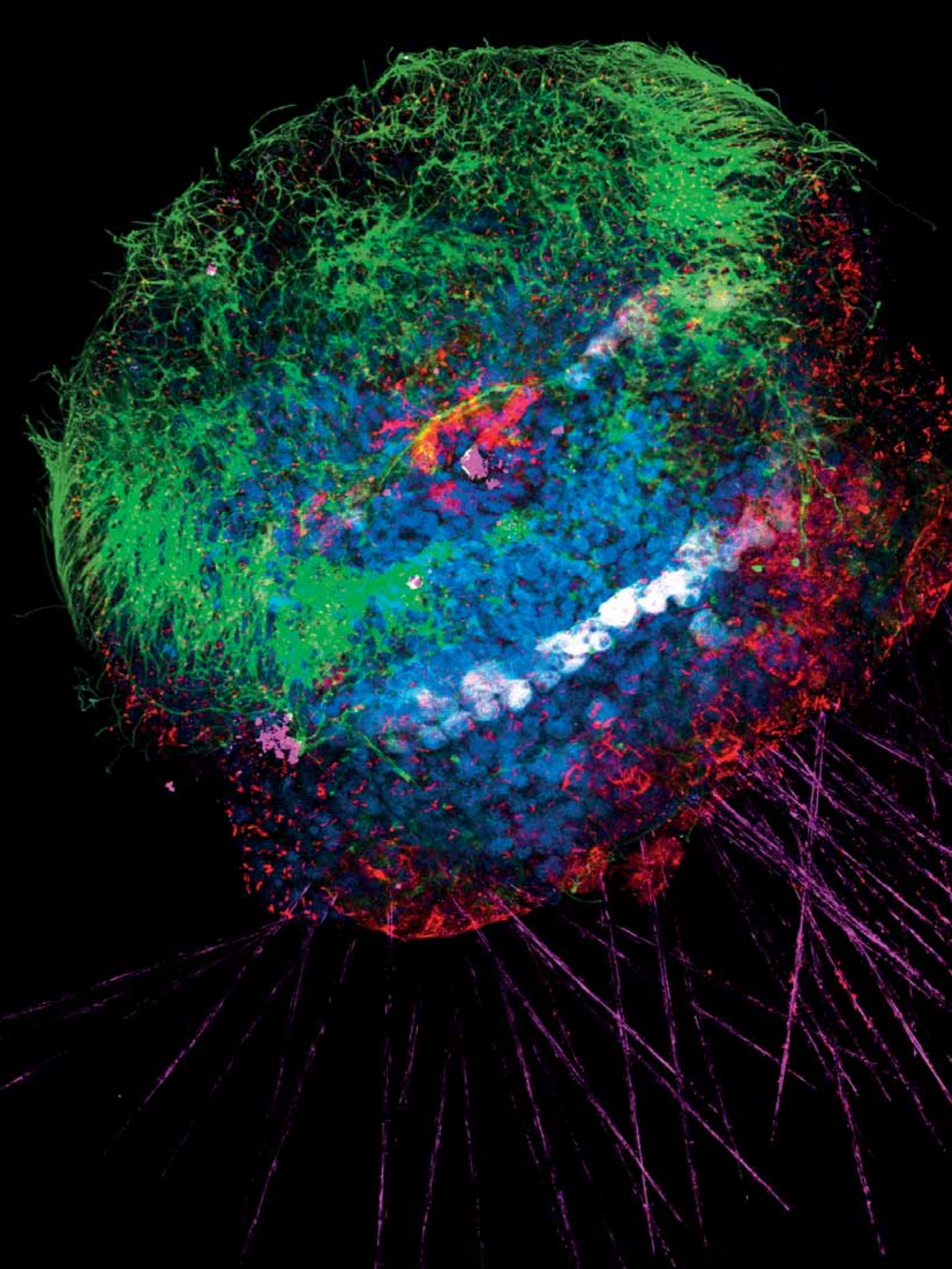

Contents

| | |
|---|-----------|
| Leica TCS SP8 – Looking Forward to Your Discoveries | 4 |
| From Whole Organisms to Highest Level of Detail | 6 |
| Innovations at a Glance | 8 |
| Sensitivity by Design | 10 |
| Faster for New Biology | 12 |
| Focus on Your Research – Automation & Reliability Redefined with Leica TCS SP8 | 14 |
| Leica Microsystems Innovation Synergies | 16 |
| Ready to Grow – Future-proof with the Leica TCS SP8 | 18 |
| Leica HyD™ – All-purpose Super-Sensitivity | 20 |
| Leica Confocal Objectives – The Best Objectives for Superior Images | 22 |
| LAS AF 3 – Intuitive Software that Makes Your Life Easier | 24 |
| Leica TCS SP8 X – Freely Tunable Excitation | 26 |
| Leica TCS SP8 STED – Opening the Gate to Super-Resolution | 28 |
| Leica TCS SP8 MP – Look Deeper into Tissues with Multiphoton Microscopy | 30 |
| Leica TCS SP8 CARS – Imaging Native Specimens without Dyes | 32 |
| Leica HCS A – Amplify the Power of Screening | 34 |
| Leica TCS SP8 SMD – Learn More from Single Molecules | 36 |
| Find the Right Leica TCS SP8 for Your Research | 38 |
| Captures and Acknowledgements | 39 |
| The Leica TCS SP8 Scan Head | 40 |

LEICA TCS SP8



Looking Forward to Your Discoveries

From routine imaging to live cell research, from super-sensitivity to super-resolution, from multiphoton imaging to CARS – whatever your research, Leica Microsystems has the confocal for your application.

SENSITIVITY BY DESIGN

The design of a confocal microscope requires excellent separation of excitation and emission light, high scan speed, and flexibility. Each photon emitted by the sample is precious and needs to be preserved. Almost all components in the optical path have an impact on the preservation of photons emitted from the sample. The best photon transmission is achieved by matching each optical component with the entire system. This central concept is integral to the design of confocal instruments by Leica Microsystems. Read more on page 11.

FASTER FOR NEW BIOLOGY

Biological research is advancing at an ever increasing rate as is the range of questions to be answered. Fast scanning provides a twofold advantage: it allows new insights into biological phenomena, and it helps meet tight deadlines. Leica Microsystems now takes speed another step further by introducing a new Tandem Scanner, along with many other innovations, to give you the results you need – faster. Read more on page 13.

READY TO GROW

As new scientific approaches unfold, so too do the instrumentation requirements to support them. With the Leica TCS SP8 you will be prepared for the new directions your research will take in the future. Leica Microsystems always ensures the path is open for the future, to help your confocal grow with changes in your experiments.

Backed by an all new user interface, for intuitive and tight control of every imaging parameter, the Leica TCS SP8 is versatile and adaptable to suit both small laboratories and large shared facilities alike. Read more on page 18.

From Whole Organisms to Highest Level of Detail



Large field – whole organism. By using an X2Y scan mirror architecture, Leica confocal systems support the largest field of view in point scanning. You can take images of whole animals or plants, often without stitching. See your specimens in widescreen.



Mosaicking (stitching) is available for samples larger than the field of view. Save time on stitching by covering the same area with a smaller number of images. Cover more ground, while preserving even the finest detail.

Leica TCS SP8 – Innovations at a Glance

Leica Confocal Scanner



FOV (Field Of View) scanner

- › See the full specimen in one shot (save time on stitching)
- › Increased time resolution
- › Higher throughput in screening experiments



Tandem Scanner

(FOV and resonant scanner combined)

- › High-speed FRAP experiments with soluble proteins
- › Improved cell viability
- › Rapid 3D particle tracking



Galvo flow (3D stacking without inertia)

- › Vibration-free, continuous movement
- › Real-time XZ-slices
- › Faster 4D imaging
- › Ideally complements rapid scanning with Tandem Scanner



Leica HyD™ (Hybrid photodetector)

- › Reduced light dosage improves cell viability
- › Ideal for high-speed imaging
- › Descanned or non-descanned detection
- › Quantitative through single photon counting (selectable)

Visible light lasers



Solid state lasers

- › Supply unit with small footprint
- › Flexible combinations of excitation lasers
- › Ideal for FRET with 448/514 nm and 488/552 nm pairs



Gas lasers

- › Most flexible choice of laser lines
- › Atomic energy transitions for monochromatic light
- › Monochromatic light source for ideal spectral separation
- › Ideal for multicolor imaging with > 4 colors



White Light Laser

- › LightGate technology for higher image contrast
- › Freely tunable excitation from 470 – 670 nm (1 nm steps)
- › Up to 8 fully tunable laser lines simultaneously from over 3 trillion unique combinations
- › Comprehensive spectroscopy imaging with 2D excitation-emission scans
- › Pulsed excitation source for FLIM and gSTED
- › Develop new imaging strategies with full spectral freedom

Intermediate optics



LIAchroics:

Low incident angle dichroic beam splitters

- › High suppression of excitation light for high contrast
- › Custom-designed low incident angle dichroics
- › Cost-efficient beam splitting



AOBS: Acousto-optical beam splitter

- › Programmable beam splitter provides the highest flexibility
- › Support of White Light Laser (WLL)
- › Completely transparent for unhindered spectroscopy
- › Steep cut-off for maximum photon efficiency
- › Longer sample viability with low power of excitation laser
- › Switching in microseconds for fast multicolor kinetics
- › Be quantitative with constant laser power using Setlight



Square pinhole

- › Ideal pinhole geometry for high resolution
- › Optimal separation of adjacent objects



SP Detector (Spectral detector)

- › Gapless emission bands for faithful rendition of fluorescence spectra
- › Multi-band spectrophotometer
- › Prism-based dispersion for highest efficiency
- › Free from photon waste

Objectives and scan optics



CS2 objectives

- › Improved color correction throughout the whole field of view
- › Perfect VIS – 405 overlay for best colocalization results



IRAPO objectives (dedicated apochromats for MP and OPO imaging)

- › High transmission in visible and infrared for brighter images from multiphoton and CARS
- › Exceptional axial and lateral color correction in the infrared for multiphoton excitation of multiple fluorophores

Scan optics dedicated to specific application ranges

- › Optimal transmission for each application
- › Dedicated intermediate optics for maximum photon efficiency
- › HIVIS from 400 – 800 nm (reduced reflection by 60%)
- › VISIR from 400 – 1300 nm
- › UVIS from 350 – 800 nm

König-Rotator: Optical scan field rotation

- › Perfect image geometry independent of rotation angle
- › High transmission for minimal losses
- › Interactivity due to direct user access by control panel

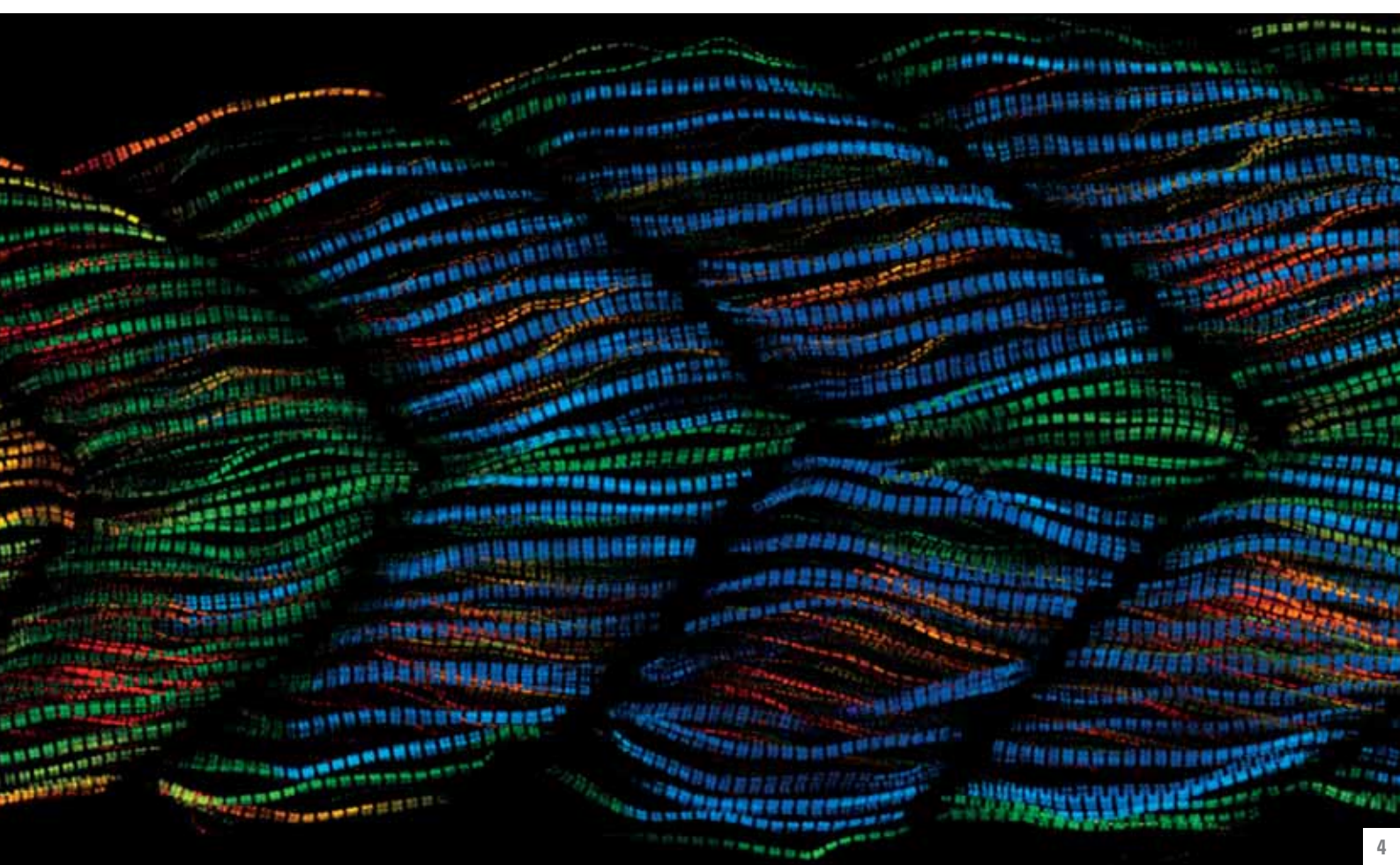

Color-coded maximum intensity projection of Zebrafish muscle. Acquired using second harmonic generation (SHG) signal excited by IR laser.



Sensitivity by Design

Designing a high precision optical instrument such as a confocal microscope is the ultimate balancing act of excellent beam splitting, high scan speed, and flexibility. At the same time, every photon emitted by the sample needs to be preserved so it can contribute to your brilliant imagery.

PRE-PROGRAMMED FLEXIBILITY

For coupling a wide range of excitation lasers into the confocal scanner, Leica Microsystems offers two options: the acousto-optical beam splitter (AOBS) and newly developed low incident angle dichroics (LIAchroics). The AOBS is an active optical crystal that is completely transparent and offers the highest photon efficiency of any beam splitting device. The AOBS maximizes the advantages of the WLL – fast tuning, using multiple laserlines simultaneously or rapid kinetic and spectroscopical analysis. Unlike filter wheels, it switches within microseconds by simply changing the radiofrequency of the acoustic wave coupled into the crystal. LIAchroics are Leica's high-efficiency beam splitters for customized performance to produce improved image contrast when compared to standard dichroics.

A STRONG TEAM

Efficient routing of fluorescence light between excitation and detection is achieved by harmonizing each optical component within the entire system. Dedicated scan optics (such as HIVIS or VISIR), optical scan field rotation, a square pinhole, and the patented SP Detector design using a Pellin-Broca prism, provide recycling-loop free dispersion. The SP Detector resembles a powerful multiband spectrophotometer, offering adaptive dynamic range because of the individual gain on each detector. The result is gapless emission bands for faithful rendition of fluorescence spectra. Consequently, the Leica TCS SP8 benefits from an overall system design philosophy that ensures all components team up to give the best results.

COUNT ON IT

Leica's digitally sampled photomultiplier tubes (PMT) pioneered the transition from analog capacitor detection to digital read-out, making pixel intensities statistically robust and optimizing detector duty cycles. In addition, the hybrid photon detectors (HyD™) by Leica Microsystems integrate next generation detection – fully multispectral and with individual gain per detector. Photon counting avoids many inherent problems of older detection principles, such as pixel convolution, noise, and voltage-related scaling issues. Backed by lightning-fast counting electronics, even very bright signals become accessible for photon counting, making quantitative measurements a routine part of your daily work.

- › Flexible and future-proof
- › Publication ready images
- › Photon efficient for live cell imaging
- › Quantitative through photon counting



TANDEM SCANNER – TIGHT SPEED CONTROL

Leica Tandem Scanners contain switchable galvanometric mirrors. The high-speed mirror resonates at either 8 or 12 kHz, which results in frame rates of more than 420 fps (at 512 x 16 scan format).

This high speed is possible because of intricate real-time control using an internal frequency calibration system. In spite of the rapid scanning the image geometry is faithfully recorded.

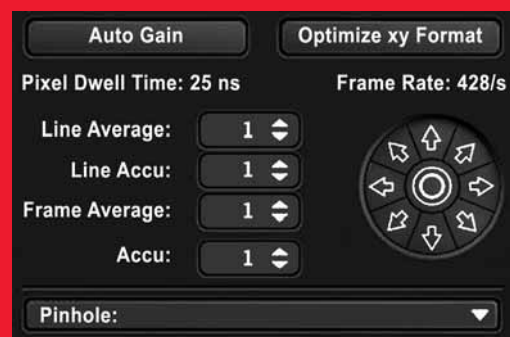

GALVO FLOW – RAPID Z-STACKING

By continuously propelling the insert rather than in discrete steps, the system minimizes inertia. This avoids an otherwise rate limiting repeated acceleration and deceleration and improves the throughput and overall speed with large 4D stacks.

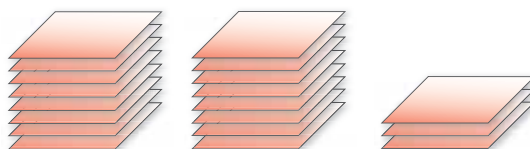

No Galvo Flow

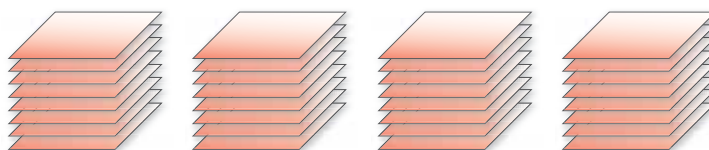

Galvo Flow



time

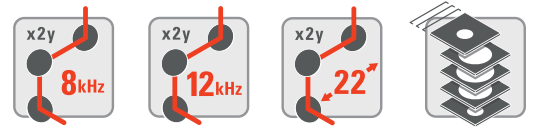

Faster for New Biology

Unveiling the processes of life is a never-ending challenge. Leica Microsystems combines innovative elements that amplify each others' performance to provide accelerated confocal image recording. Arrive at new discoveries with greater speed.

A TANDEM FOR LIVE SPECIMENS

The observation of rapid biological processes requires high-speed imaging systems. Traditional confocal scanning microscopy has an inherent limitation of serial image collection. Camera-based systems or other non-point scanning approaches sacrifice image resolution or the capability of simultaneous multichannel acquisition.

Leica Microsystems overcomes this with the Tandem Scanner, which combines the FOV scanner with a switchable resonant scanning system with either 8 or 12 kHz. The combination of photon efficient scan optics and HyD™, results in low-dosage effects for better cell viability, high-speed and perfect confocality in one.

SWEEP THROUGH LIFE

The unique z-stacking strategy of using a galvanometric stage insert provides benefits such as real-time xy-scans, beam parking in xy, and both rapid and precise 3D stacks. These are all standard on Leica confocal instruments. This tried and true approach is now extended towards high-speed using galvo flow. This results in lightning fast 4D time series acquisition, with the tandem scanner and Z Galvanometer acting in perfect harmony to give maximum xyz results.

BROADEN YOUR SCOPE

Some moments in life sciences are too precious to be missed, which is why sequential recording and stitching is not always an option. Employing their X2Y-scanner design, Leica confocal scanners allow you to see more through a wider field of view. With large specimens, you will always see the bigger picture.

- › High cell viability
- › New high-speed experiments
- › Large throughput in 4D series
- › Time-saving with large specimens

Focus on Your Research

Biological knowledge is expanding, but your time is not. Thankfully, technology can take away some of the pressure by automating the tedious and repetitive parts of experiments. Leica Microsystems can be your confocal partner, giving you the confidence to push your experimental limits and trust in your data.

READY, SET, ... LIGHT!

For quantifiable results, you need both a reliable detection system and a stable light source. A much overlooked source of imaging artifacts can be fluctuations in laser intensity. With Setlight, you maintain tight control of laser power using a built-in feedback loop. It represents an enhanced power stabilization of either white light or tunable lasers. In Leica confocal scanners with AOBs, this real-time power control system is available to reduce backtracking by creating reproducible results. Sit back and let Setlight take care of your laser power fluctuation worries.

- › More output through automation
- › Quantifiable results through power control
- › Highest reliability through optional 24/7 remote service monitoring

PEACE OF MIND WITH LEICA REMOTECARE

- › Save time managing your lab equipment
- › Safe and auditable
- › Pro-active maintenance of your confocal instrument
- › Behaves like a virtual service engineer – constantly monitors all subsystems
- › Minimizes down-time in mission-critical environments
- › Faster diagnosis – faster fixing
- › All you need is an internet connection and Leica RemoteCare





Leica Microsystems Innovation Synergies

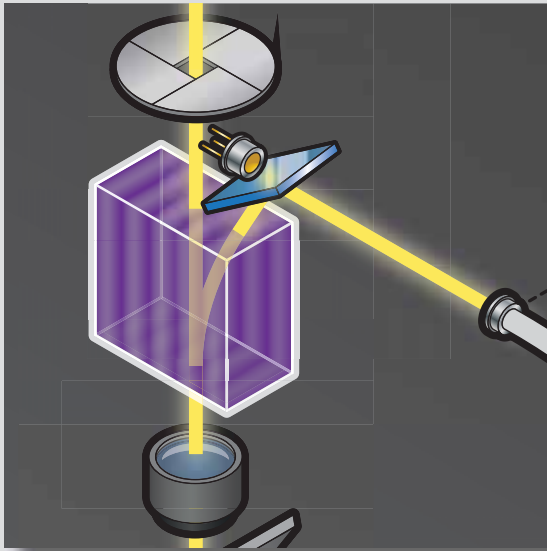

PHOTONIC EXPLORATION

The AOBs and second generation White Light Laser (unique Lightgate, FLIM, pulse picker) complete the most innovative light path concept in confocal imaging. Combine this with trillions of excitation combinations and the unique "lambda squared" scan, and you are ready to explore completely new research areas.

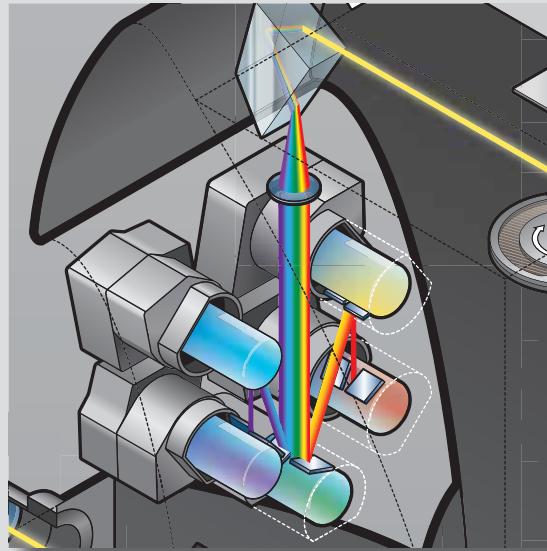

SPECTRAL FREEDOM IMAGING

For multi-channel imaging, the Leica TCS SP8 confocal prism-based spectral detection system optimizes the detection of your valuable sample's emissions. Unlike diffraction grating and barrier filter-based systems, it works at lower excitation powers for prolonged fluorescence stability.

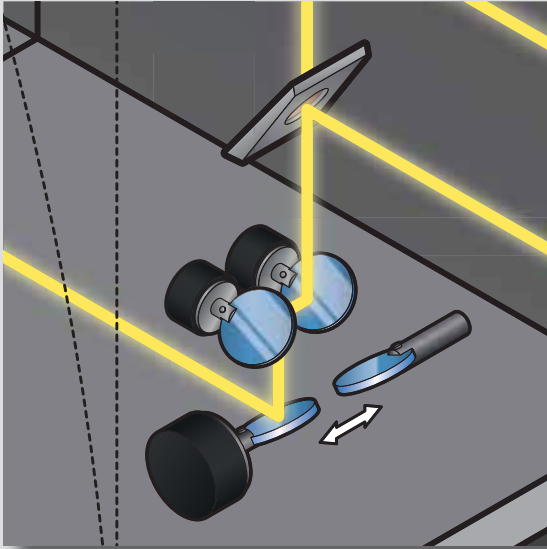

FOV SCANNER

Leica Microsystems offers the largest field of view (FOV) of any confocal point scanner. This saves you time by increasing throughput and improving image quality. This patented design is optimally backed up by the objective lenses and high pixel scan formats, as well as accelerated scan speed of a new Tandem Scanner option. With Leica confocal scanners, you get uncompromised imaging.

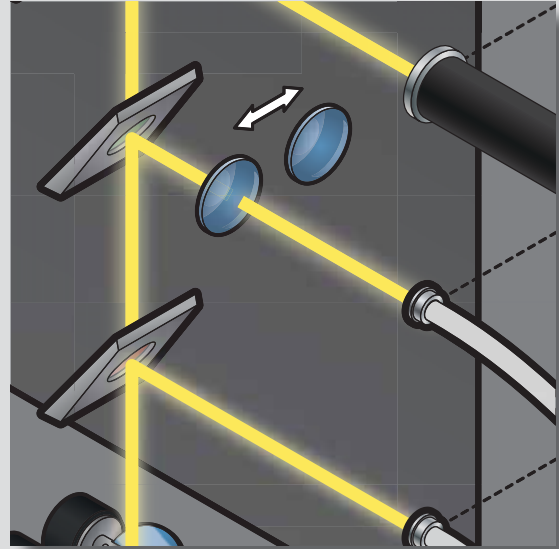

CHROMATIC PRECISION

Using newly designed CS2 optics and 405 nm laser incoupling, Leica Microsystems pushes the edge of chromatic correctness to a new level. This setup enables you to make the most of multicolor imaging and colocalization studies. After all, great imaging requires great optics.



Ready to Grow – Future-proof with the Leica TCS SP8

Life sciences are continually advancing, and it may be difficult to know which direction your research will take in the future. This is why the Leica TCS SP8 builds on a flexible concept. No matter where you start, you can configure more functionality as your needs evolve. Your investment in a Leica TCS SP8 will pay off – now and in the future.

COMPACT, WITHOUT COMPROMISE

What do you do if you are looking for a cost-efficient system that does the job but does not limit you? With its new compact supply unit, the Leica TCS SP8 allows you to buy into Leica Microsystems' high-end platform whilst starting small. This supply unit, with its small-sized footprint, solid state lasers and LIAchroic scan head, teams with the Leica DMI6000 CEL microscope to give you everything you need for high-end research. Your compact Leica TCS SP8 will grow with your research to allow the addition of more imaging detectors, more excitation lasers, and a range of multiphoton options.

MULTICOLOR FLEXIBILITY

There is always a reason to want more. More colors, more flexibility, more light. This is why the Flexible Supply Unit is equipped with a full complement of laser lines or the White Light Laser. It enables the use of up to eight gas laser lines. Atomic energy transitions deliver the most monochromatic light available. For highest performance, especially when combined with the AOBS, gas lasers still provide the best utilization of the spectral detection window. Discover the benefit of multicolor imaging.

COMPACT SUPPLY UNIT– ENTRY TO SP8 CLASS



FLEXIBLE SUPPLY UNIT– MAXIMUM SPECTRAL DETECTION WINDOW



- › Grows as your research horizons expand
- › Flexible when you need it
- › Available with additional modules of your choice:
STED, MP, SMD, CARS, HCS A

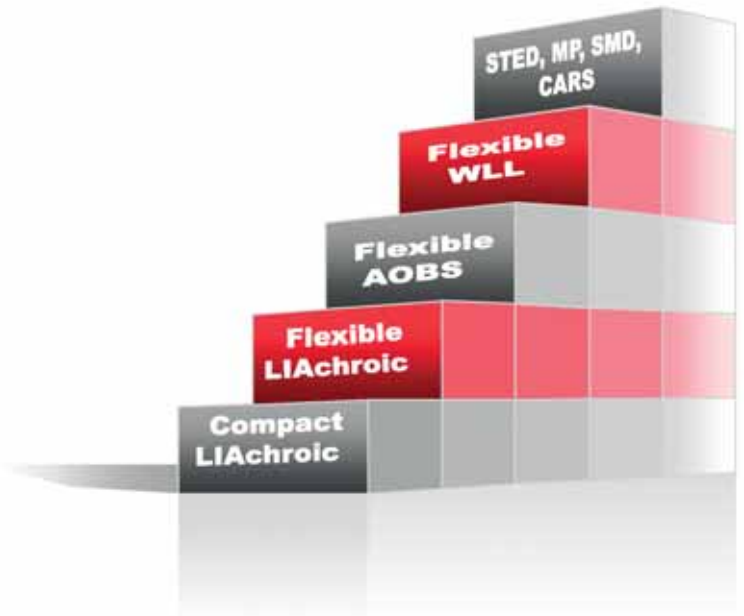

FULL SPECTRUM WITH THE WHITE LIGHT LASER CONFOCAL

Why limit yourself if you can have full spectral freedom? The White Light Laser (WLL) provides custom selection of wavelengths with multiple laser lines. In combination with the AOBS and the SP Detector, the WLL leaves nothing to be desired when it comes to visible light excitation. Multiple optimizations in the scan head, for instance mirror coatings and lens transmission, guarantee high image contrast. Now in its second generation, the WLL can serve as a FLIM source,

optionally with pulse picker, and with the contrast enhanced by Lightgate. Lightgate is a universal non-optical approach to reflection suppression, which does away with any limitations from filters.

Fill the white spots on the map with 200 colors – produced by your White Light Laser.



WHITE LIGHT LASER – TRILLIONS OF LASER COMBINATIONS



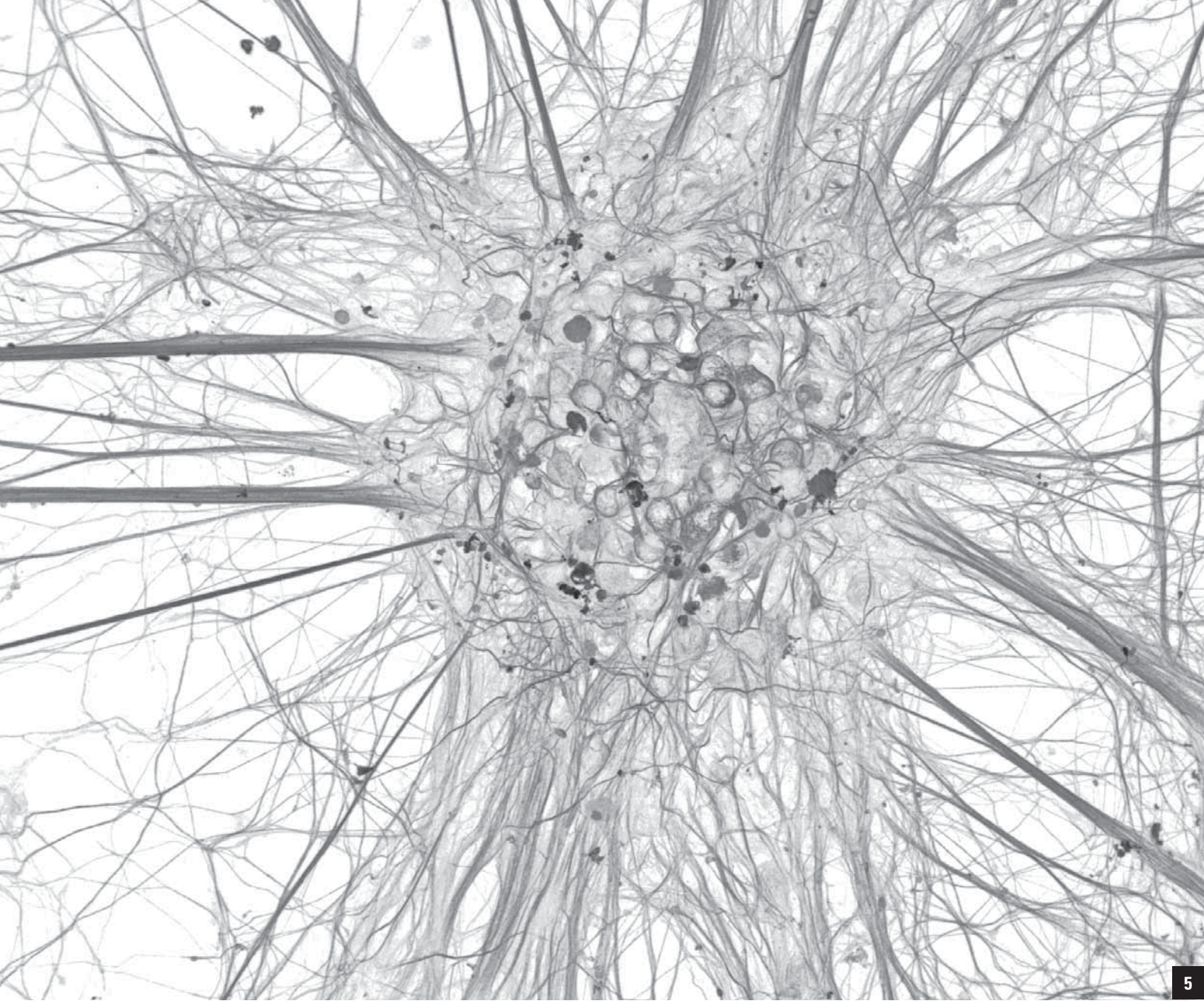

RAPID DETECTION FOR ALL PURPOSES

Unlike PMTs, which intrinsically have a longer time-of-flight for photoelectrons, HyDs™ generate ultra-short pulses. In combination with rapid sampling electronics at a 640 MHz rate, this allows precise photon counting with everyday samples. Quantitative imaging thus becomes the standard for your research.

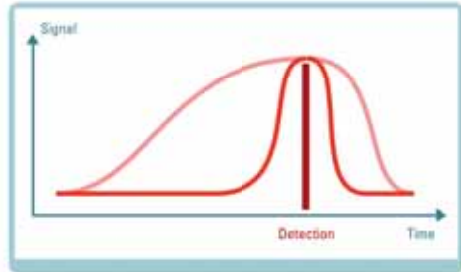
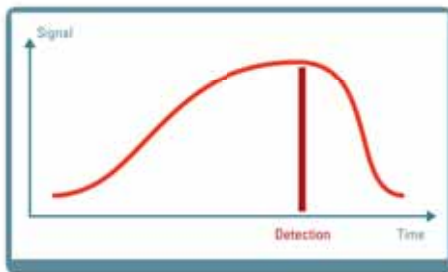
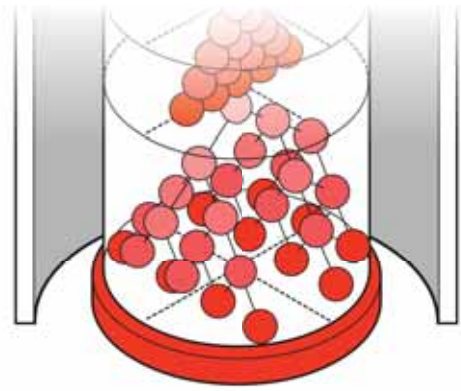
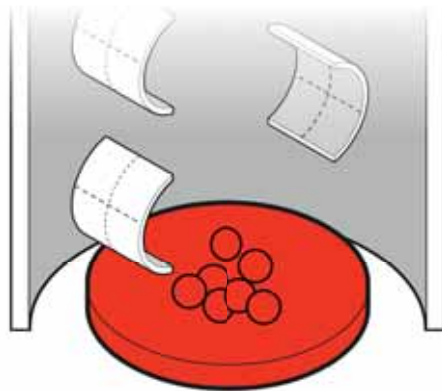

Transit Time Spread

— PMT — Hybrid Detector Transit Time Spread



Leica HyD™ – All-Purpose Super-Sensitivity

Innovation is a driving force for discovery. New areas can be uncovered by new methodologies. Leica HyD™ sets a new standard in super-sensitive imaging.

It is no longer necessary to compromise. Photon counting or imaging? Low light or bright fluorescence? High speed or crisp images? With Leica HyD™ you can do it all.

GO LIVE WITH HIGH DEFINITION

High speed and great image quality – in the past these two conflicted with each other. This is due to minimal light collection at short pixel integration times and PMTs producing a number of artefacts leading to unclear images.

Introducing a highly sensitive detection system (about 2x more quantum efficiency at 500 nm compared to typical photomultipliers) into confocal instruments solves the problem. Being an extremely responsive detection system, the Leica HyD™ produces none of the artifacts inherent to PMTs or GaAsP photomultipliers, such as after-pulsing or pixel convolution. The result is sharp images conveying every detail at high fidelity.

A VIABLE SOLUTION

Live cell imaging tends to suffer from inherent phototoxic effects. While many of the underlying mechanisms have been well understood, the effect of phototoxicity can be hard to pin down in the biological system being studied. High sensitivity directly translates into reduction in light dosage delivered to the sample. Live cell viability clearly benefits from reduced free radical concentration or photobleaching. Even delicate systems, such as yeast or worms, are accessible to Leica HyD™ Detection – at full confocal resolution.

BROADEN YOUR SCOPE

Many other highly sensitive detectors, such as traditional GaAsP photomultipliers, can age quickly and lose sensitivity. Due to its hybrid photo-detector design, the Leica HyD's photocathode and downstream amplifying elements remain sensitive. Techniques borrowed from silicon chip manufacturing and a simplified geometry, combine to produce perfectly smooth internal surfaces that are more robust. This long-term stability ensures brilliant images without compromise whenever you turn on your confocal instrument.

- › Multi-spectral detection for diverse applications
- › Reduced light dosage improves cell viability
- › Ideal for high-speed imaging
- › Quantitative through single photon counting
- › Descanned or non-descanned detector

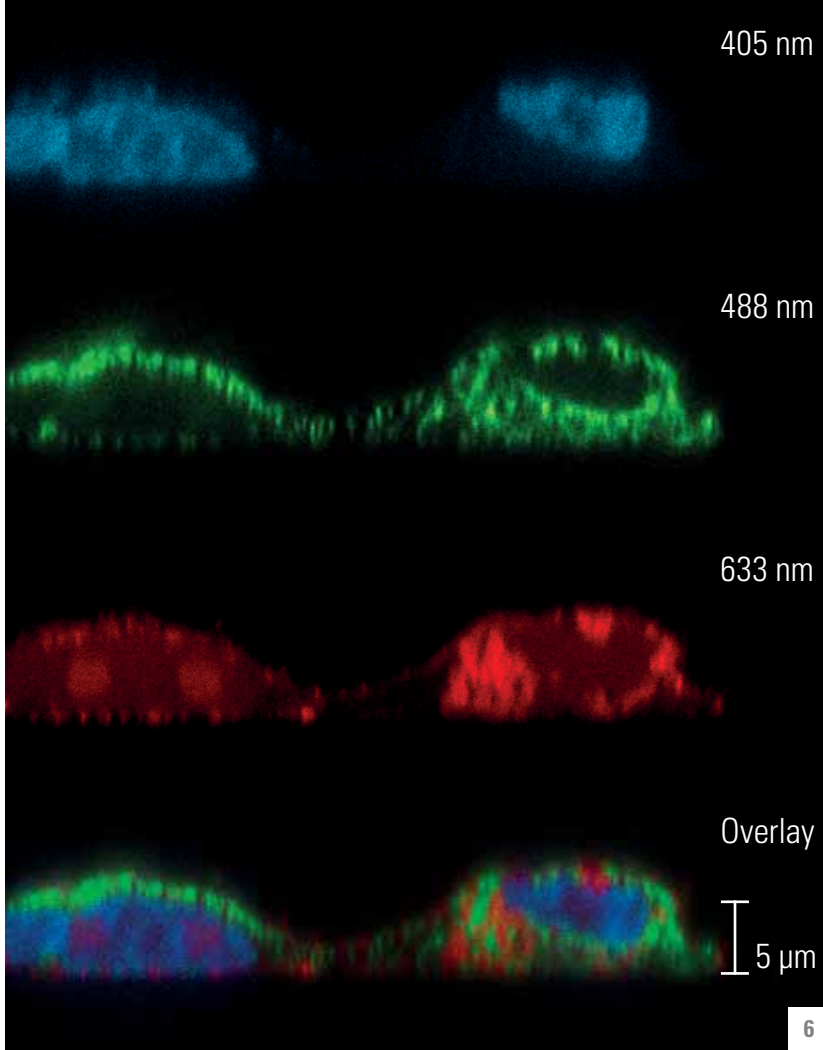

Magnification / Numerical Aperture

Immersion

Correction Collar

Confocal Scanning

Correction Collar

Corrects for variation in coverglass thickness and temperature

Immersion

Water

Oil

Glycerin

Objective Class

Magnification

| | |
|-----------|---|
| 1x/1.25x | ■ |
| 1.6x/2x | ■ |
| 2.5x/3.2x | ■ |
| 4x/5x | ■ |
| 6.3x/8x | ■ |
| 10x/12.5x | ■ |
| 16x/20x | ■ |
| 25x/32x | ■ |
| 40x/50x | ■ |
| 63x/80x | ■ |
| 100x | ■ |



Leica objectives comply with ISO8038, ISO8039, ISO8578, ISO9345-2, ISO19012-1, ISO19012-2.

The Best Objectives for Superior Images

Objectives are the eyes of every microscope and are critical to determining the resolving power of a confocal system. Transmission and color correction of an objective influence excitation and detection efficiencies. Leica Microsystems offers a broad range of high-end objectives specifically designed for the needs of different research applications. All Leica objectives are produced on state-of-the-art high precision machinery, by experienced optics engineers. The wealth of knowledge of objective assembly and optics innovation come together to provide the finest optics for the Leica TCS SP8.

OBJECTIVES TAILORED TO THE NEEDS OF YOUR RESEARCH

Only high-quality objectives allow the image resolution to reach the diffraction limit over a wide range of wavelengths. For fluorescence imaging, all excitation and detection wavelengths must be included to ensure that image resolution is as high as physically possible.

Perfect colocalization is mandatory in many studies, e.g., interaction of subcellular components. Therefore, the best achievable color correction is desired. Leica objectives cover all demands from routine fluorescence imaging to sophisticated confocal methods.

OUTSTANDING COLOR CORRECTION FOR CONFOCAL SCANNING

Leica CS objectives match the highest specifications for confocal microscopy. The chromatic correction of the new Leica CS2 objectives is perfect over the whole field of view for precise colocalization of different fluorophores. In addition, numerical aperture and free working distance are pushed to new limits.

The design of the Leica CS2 objectives goes hand in hand with the innovative UV optics of the Leica TCS SP8, to give the most stable UV color correction.

SPECIAL APPLICATIONS REQUIRE DEDICATED OBJECTIVES

Sophisticated methods such as super-resolution or multiphoton microscopy require specifically designed objectives with excellent chromatic correction and transmission in the specific wavelength range. With the Leica HCX PL APO 100x/1.40 OIL STED orange objective and the Leica IRAPO objectives, Leica Microsystems offers the best solutions for such applications. High-resolution water immersion objectives with correction collars are a prerequisite for aberration-free imaging in aqueous samples such as living cells. To provide stable water immersion even at 37°C, the Water Immersion Micro Dispenser automatically adds water during an experiment. With the motorized correction collar, precise adjustment of the optics is easy and reliable.

Leica (Semi-)Aplanatic Objectives (coming from Greek: without color)

| | |
|----------------------|---|
| HCX PL Fluotar | affordable quality, suitable for fluorescence imaging |
| HC PL APO/HCX PL APO | superior color correction and field flatness |
| HCX PL APO CS | optimized for confocal scanning (CS) |
| HC PL APO CS2 | new generation of CS objectives |
| HC PL IRAPO | color correction and transmission optimal for MP and CARS |

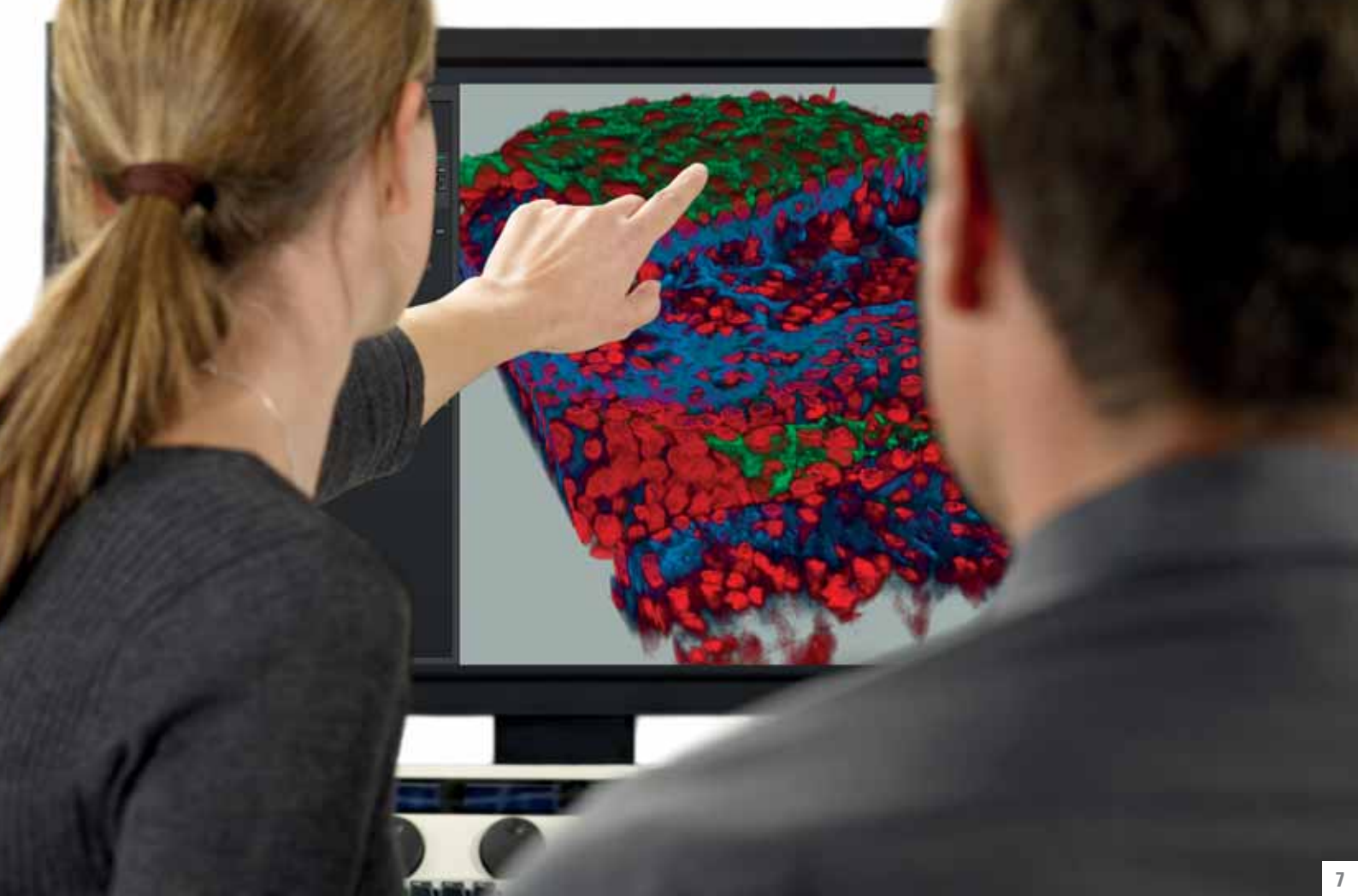

This is a screenshot of a microscope control software interface. The top navigation bar includes tabs for 'Configuration', 'Acquire' (which is active), 'Process', and 'Quantify'. Below this, there are sections for 'Experiments' and 'Acquisition' with various settings like 'XY: 512x512 | 400 Hz | 1.68 | 1.00 AU'. The central part of the interface features an optical path diagram with a 'Specimen' label and a color-coded spectral response graph. Below the diagram are controls for 'X1 Port', 'Beamsplitter', 'Objective', and 'MFP'. At the bottom, there are several PMT (Photomultiplier Tube) settings, including 'PMT 1' (Leica/DAPI), 'PMT 2' (Leica/ALEXA 488), 'PMT 3' (Leica/ALEXA 568), and 'PMT NDD1' and 'PMT NDD2'. The interface is dark-themed with various sliders, buttons, and dropdown menus.

Intuitive Software that Makes Your Life Easier

LAS AF 3 (Leica Application Suite Advanced Fluorescence) microscope software guides the user step by step through data recording and evaluation. The workflow design helps you to use the Leica TCS SP8 more efficiently. It offers full control over the microscope hardware and provides all necessary information at a glance.

CLEAR STRUCTURE SAVES TIME AND LEARNING EFFORT

Clearly structured panels for the configuration of each acquisition step can be permanently opened or hidden, providing exactly the information you need. The ergonomic design of LAS AF 3 reduces the learning effort and allows you to focus on your research instead of learning to use the software. LAS AF 3 is fully synchronized with the programmable control panel, which allows interactive and fast setup.

The interface of LAS AF 3 is optimized for operation in dark rooms, reducing stray light from computer screens. For better visibility, the complete user interface can be magnified. Now, imaging facilities can efficiently teach larger groups of users, reducing the time spent on training. LAS AF 3 has the same architecture across all Leica microscope platforms, giving you familiarity and confidence for fast and accurate results.

CUSTOMIZED SOFTWARE TO MEET YOUR NEEDS

In addition to basic image acquisition, LAS AF 3 can be extended with a range of additional software packages. Software wizards reduce the time spent on configuring tools, and even less experienced users can perform complex experiments within a short time.

The LAS AF Microlab package consists of several wizards optimized for fast photomanipulation experiments (FRAP, FLIP, photoconversion) and FRET.

LAS AF Live Data Mode is a tool for the easy setup of complex, interactive time-lapse experiments. LAS AF Electrophysiology combines Live Data Mode with the recording of electrophysiological data. The extremely flexible Leica HCS A provides all the tools for easy automation of high-content screening (see page 35).

IMAGE ACQUISITION, PROCESSING, AND QUANTIFICATION IN ONE PACKAGE

A variety of processing tools, including deconvolution and advanced 3D visualization bring out the most important details of your data without the need for external software. The new 3D visualization tool offers GPU-based processing of 3D datasets with novel manipulation options and a movie maker to create astonishing animations.

Guided evaluation steps within the wizards help with the quantification of complex experiments for quick and accurate analysis. All processing and quantification packages are fully integrated in LAS AF 3 for fast and intuitive data handling. When used offline, they free up time at the microscope itself. For custom analysis and documentation, data can be exported in common image and movie formats, including OME-TIFF.

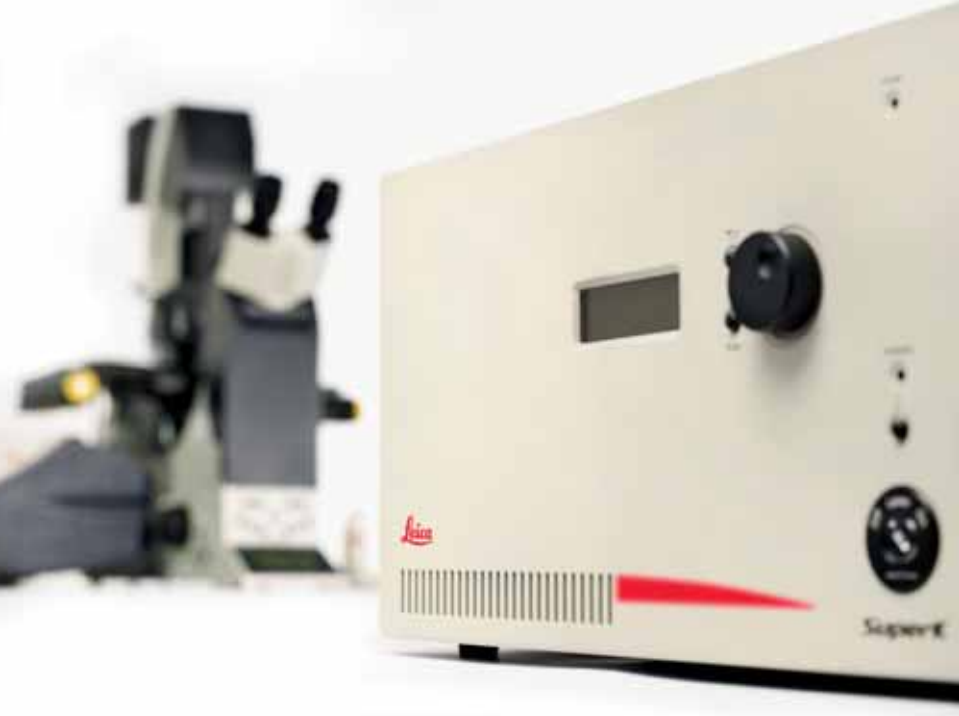

Continuously tunable excitation:
best image quality and sample protection.

Lambda Square Mapping: full spectral information from your sample by excitation-emission correlation.

Tunable wavelength and pulse picking: true FLIM results.

Up to 8 laser lines simultaneously – freely tunable in wavelength and intensity.

Tuning range of 470 to 670 nm in 1 nm intervals.

Illumination regimes can be applied within microseconds.

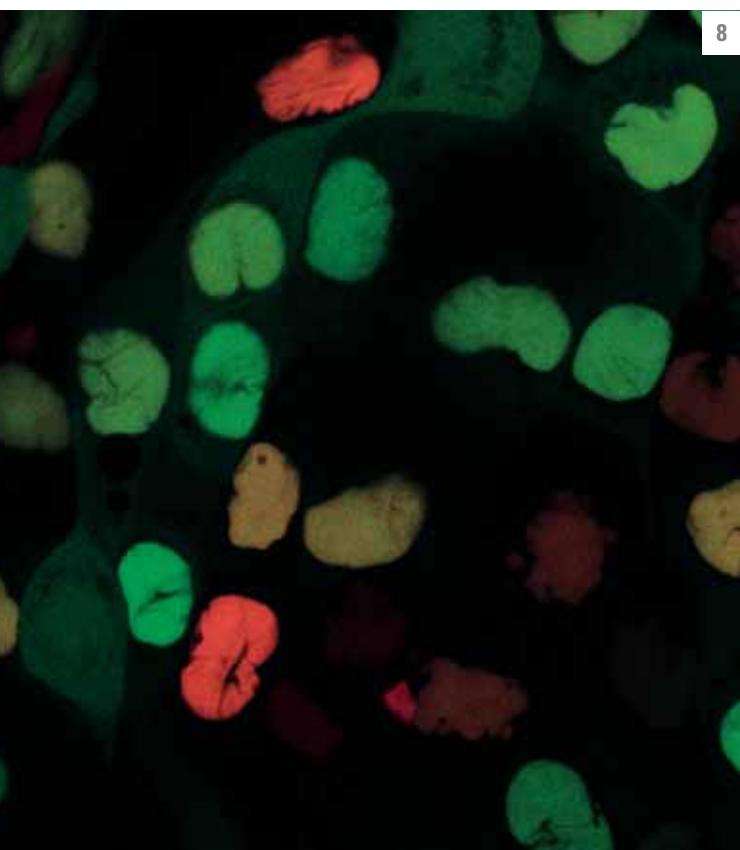
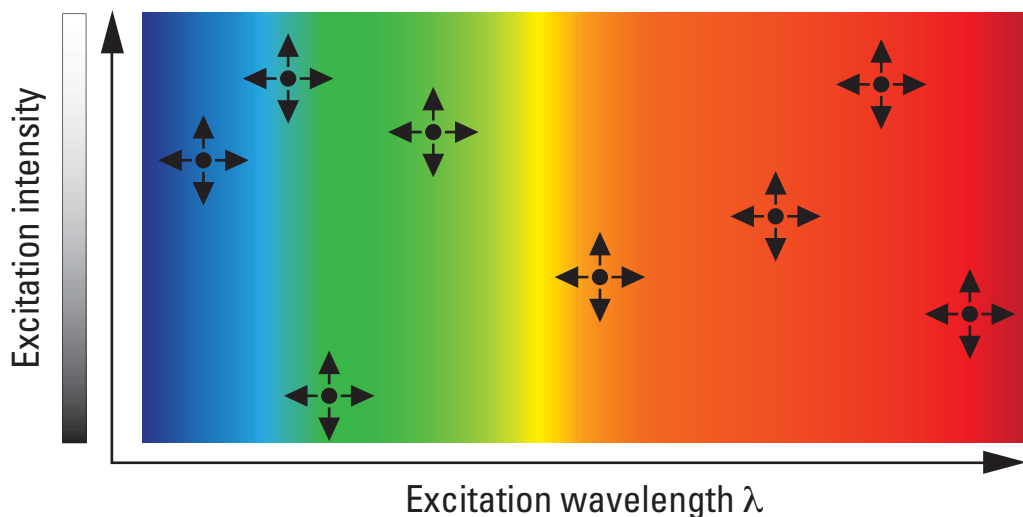

Non-S1 phase

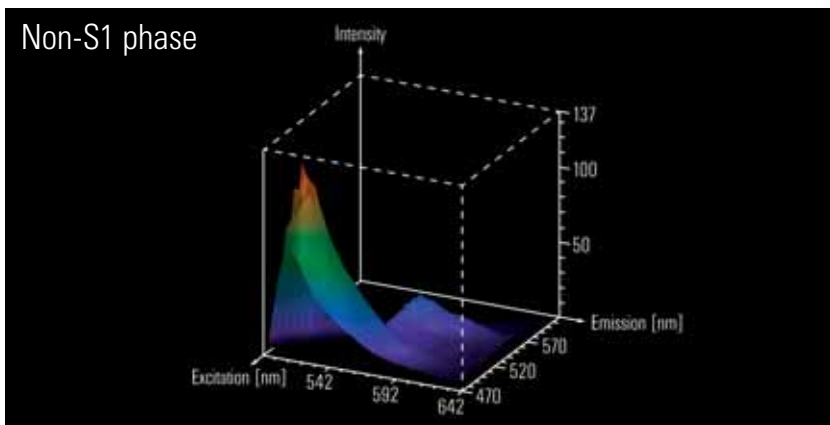

S1 phase

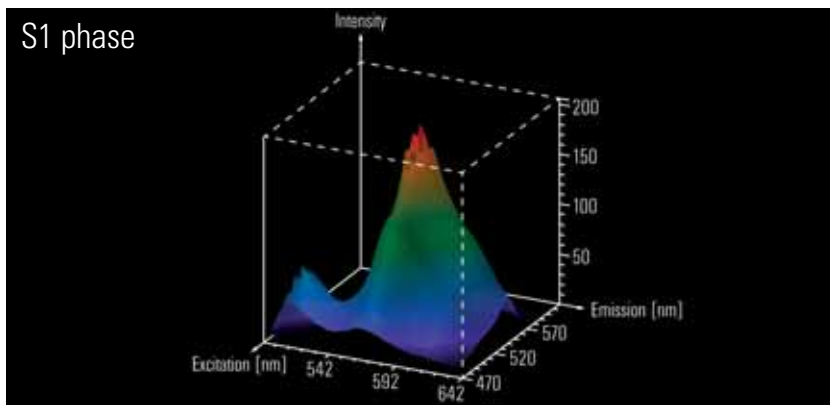

Freely Tunable Confocal Imaging

Is there an optimal excitation source to image any kind of dye combination – suitable even for FLIM measurements? Yes – the Leica White Light Laser. The Leica TCS SP8 X based on the White Light Laser (WLL) offers this level of flexibility. The acousto-optical beam splitter (AOBS) is the key to selecting any wavelength from the white spectrum. Completed by the tunable spectral detector (SP), the Leica TCS SP8 X represents the only filter-free versatile confocal microscope.

BACKGROUND QUENCHING WITH TIME GATED DETECTION USING LIGHTGATE

LightGate imaging

Time gated imaging is an ingeniously flexible approach that excludes unwanted light from emission collection. It switches off data collection during the White Light Laser pulse; the desired photons are harvested only during an adjustable LightGate window. This way, the highest image contrast is obtained.

- › Improvement of image quality in reflection-sensitive samples
- › Maximizing fluorescence harvest when working with short Stokes-shift dyes
- › Dye discrimination by fluorescence decay time using light gate adjustment

SEPARATION OF FLUOROPHORES IN SPECTRALLY COMPLEX MIXTURES

Lambda Square Mapping

The lambda square map uncovers the sample dependent relationship between excitation and emission spectra. An automated acquisition process collects the related spectral data, which is summarized in a two-dimensional intensity map.

- › Best image quality by optimization of spectral instrument parameters
- › Characterization of new fluorescent markers
- › Selection of optimal specific stains that sidestep auto-fluorescence

OPTIMIZED EXCITATION WAVELENGTH AND REPETITION RATE

White Light Laser FLIM

The White Light Laser allows you to set the FLIM excitation wavelength as desired. The repetition rate is variable due to a built-in pulse picker from 10 to 80 MHz. Pulse picking and wavelength selection are fully integrated into the LAS AF 3 software.

- › One laser for all: versatile and convenient illumination selection for imaging and FLIM
- › Filter-free FLIM: fluorescence lifetime measurements at tunable excitation and emission wavelengths
- › True FLIM data by adapting the repetition rate to the fluorescence lifetime

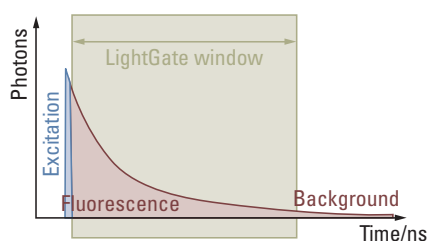

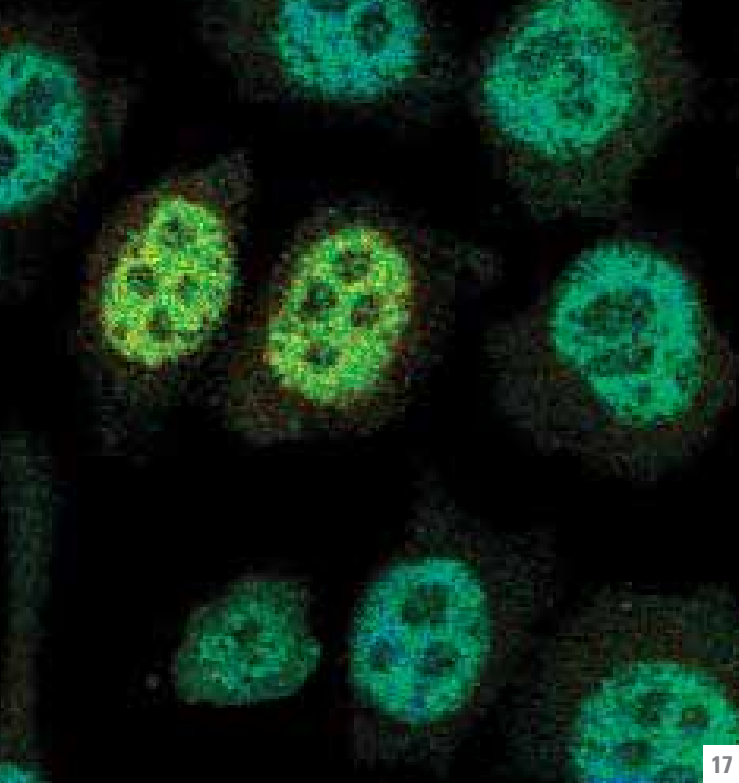

Binding studies using FLIM FRET. Shorter donor fluorescence lifetime indicates binding.

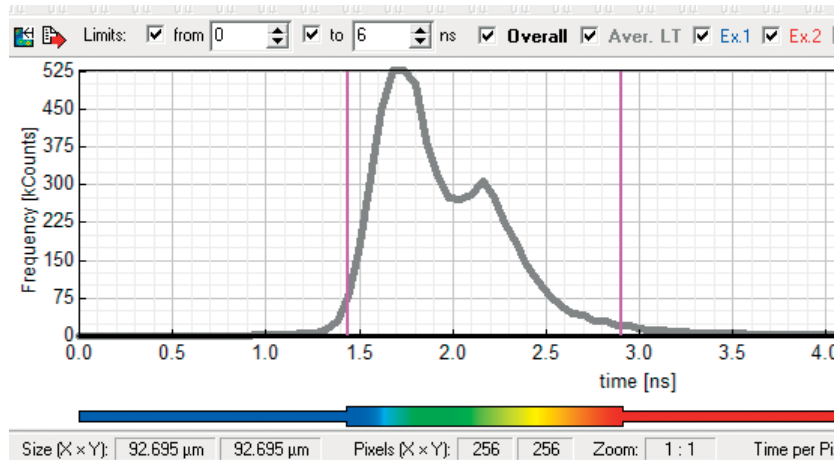

Multiparametric data analysis of dynamic processes using FCS:

The autocorrelation curve reveals information on the molecular scale such as diffusion coefficient, particle mass, and concentration. An increase of the cross correlation amplitude (FCCS) signifies binding processes.

Specimen: double stranded DNA labeled with Alexa 488 and Cy5.

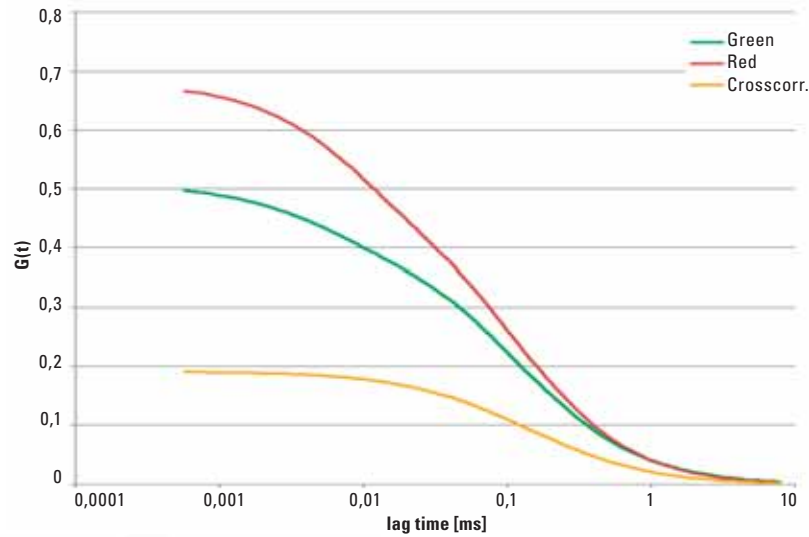

Leica TCS SP8 SMD:

An integrated platform for FCS, FLIM, FLCS, and imaging methods.

User-friendly implementation of all Leica and PicoQuant components.

Dedicated application wizards for fast, reliable experimental setup.

Learn More from Single Molecules

Quantitative characterization of biological phenomena is gaining increasing importance in modern life science. The Leica TCS SP8 SMD offers all you need for quantification – at the push of a button. Established confocal image acquisition procedures combined with sophisticated single molecule tools are opening up entirely new areas of research.

The Leica TCS SP8 SMD provides global control of an experiment through the full integration of SMD-specific hardware and software from PicoQuant GmbH. A wide variety of lasers – from UV to IR and the unique pulsed White Light Laser – are available. Specific single photon counting detectors for external or internal spectral data acquisition fit all applications.

ANALYSIS OF MOLECULAR NANO-ENVIRONMENT AND FLUOROPHORE PROPERTIES

FLIM/Spectral FLIM

Fluorescence Lifetime Imaging (FLIM) measures the average lifetime that molecules reside in the excited state. The resulting images show the fluorescence life span in each pixel. Modern biosensors use that property to very sensitively probe molecular environmental parameters and binding by FRET-FLIM. New dyes are precisely characterized with FLIM methods.

- › Deep tissue MP-FLIM with non-descanned Leica HyD™ for large z-stacks with high signal-to-noise ratio
- › PIE (Pulsed Interleaved Excitation) at the push of a button

QUANTIFICATION OF MOLECULAR MOVEMENT AND INTERACTION

FCS/FCCS

Fluorescence Correlation Spectroscopy (FCS) analyzes the intensity fluctuations caused by the entry and exit of fluorescent molecules in a fixed diffraction limited laser focus. An autocorrelation of the signal provides quantitative insight into transport properties and dye distribution. Molecular binding becomes evident in Fluorescence Cross-Correlation Spectroscopy (FCCS).

- › Profile-scan positioning for precise aiming at membrane-associated targets
- › Automated control image acquisition during FCS sequences

EVALUATION OF MOLECULAR DYNAMICS IN DIFFICULT SAMPLES

FLCS/FLCCS

Fluorescence Lifetime Correlation Spectroscopy (FLCS) combines FCS and lifetime measurement, where lifetime-filtered data are correlated. This approach extracts significant fluctuation data from unwanted noise signals. Concentration measurements at low signal levels or high background reveal true data.

- › Inherent cross-validation of FCS and FLIM data
- › Clearly enhanced cross-correlation by seamless integration of PIE illumination

| Applications | Methods | Solutions |
|-------------------------------|---------------------------|-------------------------|
| Colocalization studies | STED super-resolution | Leica TCS SP8 STED |
| | Confocal imaging | Leica TCS SP8 |
| | FRET | Leica TCS SP8 |
| | FLIM-FRET | Leica TCS SP8 SMD FLIM |
| | Multiphoton | Leica TCS SP8 MP |
| Live cell imaging | CARS | Leica TCS SP8 CARS |
| | Multiphoton | Leica TCS SP8 MP |
| | FLIM | Leica TCS SP8 SMD FLIM |
| | FCS | Leica TCS SP8 SMD FCS |
| | FLCS | Leica TCS SP8 SMD FLCS |
| | High content screening | Leica HCS A |
| | STED super-resolution | Leica TCS SP8 STED |
| | FRAP/FLIP/photoconversion | Leica TCS SP8 |
| | Super-continuum imaging | Leica TCS SP8 X |
| | Low light imaging | Leica TCS SP8 with HyD™ |
| | Time-lapse recording | Leica TCS SP8 |
| | Fast tracking | Leica HCS A |
| Quantitative imaging | Photon counting | Leica TCS SP8 with HyD™ |
| | FLIM | Leica TCS SP8 SMD FLIM |
| | FCS | Leica TCS SP8 SMD FCS |
| | FLCS | Leica TCS SP8 SMD FLCS |
| | High content screening | Leica HCS A |
| Super-resolution | STED super-resolution | Leica TCS SP8 STED |
| Deep tissue imaging | CARS | Leica TCS SP8 CARS |
| | Multiphoton | Leica TCS SP8 MP |
| | Electrophysiology | Leica TCS SP8 MP + CFS |
| 3D imaging | STED super-resolution | Leica TCS SP8 STED |
| | Multiphoton | Leica TCS SP8 MP |
| | Confocal imaging | Leica TCS SP8 |
| | Confocal imaging | Leica TCS SP8 with HyD™ |
| | Super-continuum imaging | Leica TCS SP8 X |
| | High content screening | Leica HCS A |
| Label-free imaging | CARS | Leica TCS SP8 CARS |
| | FLIM | Leica TCS SP8 SMD FLIM |
| | Spectral characterization | Leica TCS SP8 X |

Image Captions and Acknowledgements:

Title page:

First: Mouse retina. Sample: courtesy of Dr. Frank Müller, Institute of Complex Systems 4, Cellular Biophysics, Research Center Jülich GMBH, Jülich, Germany

Second: Mouse diaphragm. Green: nerve fiber, Alexa 488. Red: synapses, Rhodamin. Blue: muscle fiber, myosin. DODT contrast. Sample: courtesy of Ulrike Mersdorf, Max Planck Institute for Medical Research, Heidelberg, Germany

Third: Food moth (*Plodia interpunctella*), larval silk gland. 10x magnification, overlay image. Red: fat cells under the cuticula. Green: cuticula. Leica Microsystems

Fourth: Dual color STED image. Green: histone 3. Red: microtubules. Both visualized in HeLa cells with Chromeo 505 and BD HorizonV500, respectively. Leica Microsystems

- [1] Larvae of *Terebratalia transversa*. Sample: courtesy of Prof. Andreas Wanninger, Vienna, Austria
- [2] *Platynereis dumerillii*, (2 month). Blue: nuclei, DAPI. Green: tubulin, FITC. Grey: phalloidin, Rhodamin. Red: serotonin, Cy5. 3D maximum projection of image taken with a 10x objective fully zoomed out at 5000 x 5000 scan format. Sample: courtesy of Dr. Antje Fischer and Dr. Detlef Arendt, Heidelberg, Germany
- [3] Coronar section of mouse nasal cavity. Mosaic compiled from 48 single images acquired using a high NA objective lens. Leica Microsystems
- [4] Zebrafish muscle – SHG. Sample: courtesy of Dr. Patrick Kölsch, Karlsruhe Institute of Technology, Karlsruhe, Germany
- [5] Rat primary culture. Leica Microsystems
- [6] HeLa cells. Blue: Nucleus, DAPI. Green: Tubulin, Alexa 488. Red: F-actin, TRITC-phalloidin, Excitation wavelengths are indicated for each channel. Leica Microsystems
- [7] Detail of mouse embryo heart. Blue: nuclei stained with DAPI. Green: Cy2 labelled actin. Red: uncharacterized protein labeled with Cy5. Courtesy of Dr. Elisabeth Ehler, King's College, London, UK
- [8] Cells expressing a cell cycle stage marker. Green: non-S1 phase. Red: S1 phase. Yellow: intermediate state. Courtesy of Dr. Malte Wachsmuth and Dr. Lars Hufnagel, EMBL, Heidelberg, Germany
- [9] Dual color confocal and STED image. Green: histone 3. Red: microtubules. Both visualized in HeLa cells with Chromeo 505 and BD Horizon V500, respectively. Leica Microsystems
- [10] Adult Thy1-EYFP H line mouse, *in vivo* (cranial window). Excitatory pyramidal neurons in Layer 5 partly express EYFP. Courtesy of Dr. Masahiro Fukuda and Prof. Haruo Kasai, Center for Disease Biology and Integrative Medicine, Faculty of Medicine, The University of Tokyo, Tokyo, Japan
- [11] *Drosophila melanogaster*, living animal. Red: fat cells imaged at a wave number of 2850 cm⁻¹ (at 816 nm). Green: two different structures displayed in green autofluorescence (at 1064 nm): Long tubes are parts of the tracheal system, striped matter in the background are muscles. Objective: Leica HCX IR APO L25x/0.95 W 0.17. Leica Microsystems
- [12] Structural information of a food moth larvae *Plodia interpunctella*. Red: CH₂ stretches imaged at a wave number of 2850 cm⁻¹ (at 816 nm). Green: parts of cuticula displayed in green autofluorescence, green filaments are the bristles of the larvae (at 1064 nm). Leica Microsystems
- [13] Distribution of fatty components in potato crisps. Maximum projection. Red: lipid components in all regions of a potato chip. Green: structural information provided by autofluorescence. Leica Microsystems
- [14] Mouse diaphragm muscle stained against neurofilament 150. Mosaic: xyz: 5 x 5 x 101 images. Green: secondary antibody coupled to Alexa Fluor 488 and acetylcholine receptors. Red: alpha-bungarotoxin coupled to Alexa Fluor 647. Courtesy of Dr. Rüdiger Rudolf, Cellular Signaling in Skeletal Muscle, Karlsruhe Institute of Technology, Karlsruhe, Germany
- [15] Zebrafish brain, *in vivo* imaging. Transgenic embryo, *Danio rerio*. GFP, epithalamus, optic tectum. Courtesy of K. Palma, N. Guerrero, L. Armijo, ML. Concha, Laboratory of Experimental Ontogeny (LEO), S. Härtel, Laboratory of Scientific Image Analysis (SCIANLAB). Anatomy and Developmental Biology Program, ICBM, Faculty of Medicine, University of Chile, Santiago, Chile
- [16] Zebrafish, novocord development, *Danio rerio*. Tracking the development of life over time. Red: Rhodamine-dextran. Green: GFP, labeling of the novocord. Courtesy of Sophie Dal-Pra, Team B&C Thisse, Imaging Centre of IGBMC, IGBMC, Illkirch, France
- [17] Nuclei of HeLa cells. Polymerase B labeled with Alexa 488 and Alexa 555 as a positive control for FRET, and donor bleached cells as negative control. Courtesy of Pascal Kessler and Yves Lutz, IGBMC, Strasbourg, France

Leica TCS SP8 Scan Head



visible and ultraviolet radiation:



infrared radiation:

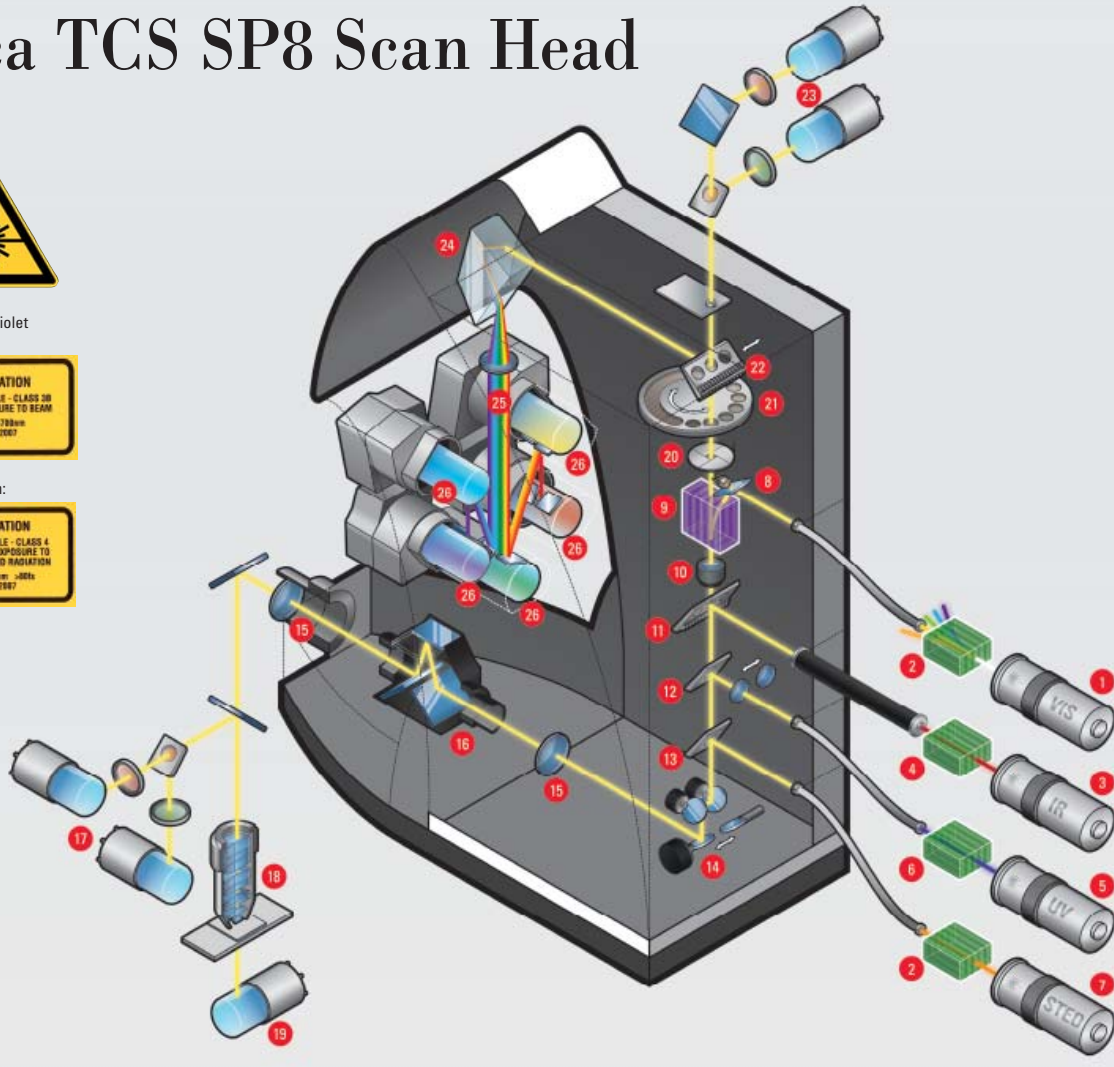

- | | |
|---|---|
| 1 Visible line lasers or White Light Laser | 15 Scan optics with alternative UVIS, HIVIS or VISIR coating |
| 2 Acousto-optical tunable filter (AOTF) | 16 Scan field rotation (Abbe-König rotator)* |
| 3 Infrared (IR) lasers * | 17 Reflected light detection (RLD) in non-descanned position * |
| 4 Electro-optical modulation (EOM) | 18 Objective lens (different options available) |
| 5 Ultraviolet (UV) lasers * | 19 Transmitted light detection (TLD) in non-descanned position * |
| 6 AOTF or direct modulation (DMOD) | 20 Square confocal pinhole |
| 7 STED laser * | 21 Fluorifier disc * |
| 8 Monitoring diode for Setlight | 22 Outcoupling with X1 port * |
| 9 Acousto-optical beam splitter (AOBS), other options available | 23 External detection * |
| 10 FRAP Booster * | 24 Prism-based dispersion |
| 11 IR laser incoupling | 25 SP detection with spectrophotometer arrangement |
| 12 UV laser incoupling with CS2 UV optics | 26 Up to five photomultipliers (PMT) or up to four hybrid photodetectors (HyD™) |
| 13 STED laser incoupling | |
| 14 FOV scanner with tandem scanner option | |

*optional

