

# LEON CUP RACER



2015

TECHNICAL MANUAL



**Table of contents**

1	TECHNICAL INFORMATION .....	4
1.1	Leon Cup Racer Display.....	4
1.2	Dimensions and weights.....	5
1.3	Body shell .....	6
1.4	Powertrain.....	7
1.5	Rim & Tire.....	9
1.6	Electronic units.....	9
2	DRIVERS CONTROL .....	11
2.1	Main console .....	11
2.2	Steering wheel module .....	11
2.3	Gear lever functions .....	14
2.4	Standing start procedures .....	15
2.5	Speed limiter system.....	15
2.6	Driver has to consider .....	16
2.7	Display alarms and shift lights .....	12
3	DISPLAY & FUSE BOX.....	17
3.1	Display alarms and shift lights .....	18
3.2	Data acquisition analysis.....	19
3.3	MXG channel expansion scheme .....	20
3.4	Fusebox .....	22
3.5	Auxiliary connectors .....	24
4	SETTING ADJUSTMENTS.....	26
4.1	Car delivery set-up .....	26
4.2	Steering rack centring.....	27
4.3	Suspension adjustments .....	27
4.4	Front Camber and Toe adjustment.....	27
4.5	Rear Camber and Toe adjustment .....	28
4.6	Dampers.....	29
4.7	Antiroll bars.....	31
4.8	Kinematics .....	32
4.9	Brakes .....	34
4.10	Aero .....	34

5	WORKSHOP MAINTENANCE .....	35
5.1	First rollout .....	35
5.2	Check list .....	35
5.3	Vehicle & parts identification.....	36
5.3	Fluids information .....	37
5.4	Engine service.....	37
5.5	Air filter .....	38
5.6	Gearbox control & service.....	39
5.7	FDX - Slip differential control & service.....	39
5.8	Fuel .....	40
5.9	Electronic modules .....	41
5.10	Airjack.....	42
6	PARTS MILEAGE.....	43
7	SAFETY .....	44

## 1 TECHNICAL INFORMATION

### 1.1 Leon Cup Racer Display

#### Engine

\ Type.....	Turbocharged; 4-cylinder in line
\ Fuel supply system.....	Direct fuel injection
\ Displacement (cc).....	1984 cc
\ Bore and stroke (mm).....	82,5 x 92,8
\ Maximum power (hp/rpm).....	330 hp / 6200 rpm
\ Maximum torque (Nm/ rpm).....	410Nm / 2000 to 5000 rpm
\ Electronic control unit.....	Continental SIMOS
\ Exhaust/dB.....	Racing catalysed 104dB
\ Fuel tank capacity.....	55 l standard quattro version tank
\ Speed limiter system.....	Active 60km/h
\ Launch control system.....	Available

#### Transmission

\ Transmission.....	Front-wheel-drive
\ Gearbox.....	6 speed DSG dual clutch S-tronic
\ Differential.....	VAQ, electro-hydraulic in front axle
\ Clutch.....	Two electro-hydraulically operated oil-immersed multi-plate clutches
\ Shift control.....	Electronic on steering wheel

#### Chassis and Suspension

\ Front suspension.....	McPherson, adjustable in height, toe and camber
\ Anti-roll bar.....	Front and rear adjustable
\ Rear suspension.....	Multi-link axle, adjustable in height, toe and camber
\ Front brakes.....	6-piston callipers, 362 mm steel ventilated discs
\ Rear brakes.....	272 mm steel discs
\ Brake pedal.....	Unitary with brake balance regulation
\ Steering system.....	Full electrical power steering rack
\ Rims.....	Seat Sport 10"x18"
\ ABS.....	Removed

#### Body and aerodynamics

\ Roll bar driver position.....	FIA homologated and Hans adapted
\ Weight.....	1.120 kg
\ Front width (max).....	1.950 mm
\ Rear width (max).....	1.950 mm
\ Length.....	4.363 mm
\ Wheel base.....	2.666 mm

#### Car check-control

\ Acquisition system.....	AIM - MXG 28 channels + 8 analogics
\ Car check-control.....	Auto-diagnosis OBDII / DiagRA - LE
\ Airjack.....	Complete car kit
\ Fire extinguishing system.....	OMP CESAL 2

## 1.2 Dimensions and weights

Dimensions	Measurements	Remarks
Overall length	4382 mm	
Overall bodywork front width	1950 mm	Measured on the mud-ward at the front axle
Overall bodywork rear width	1950 mm	Measured on the mud-ward at the rear axle
Wheel base	2665 mm	
Over hang front splitter	897 mm	
Over hang front bumper	868 mm	
Over hang rear	820 mm	
Over hang rear wing	165 mm	From the wing to the bumper
Minimum ground clearance	free	70 mm is the performance recommendation

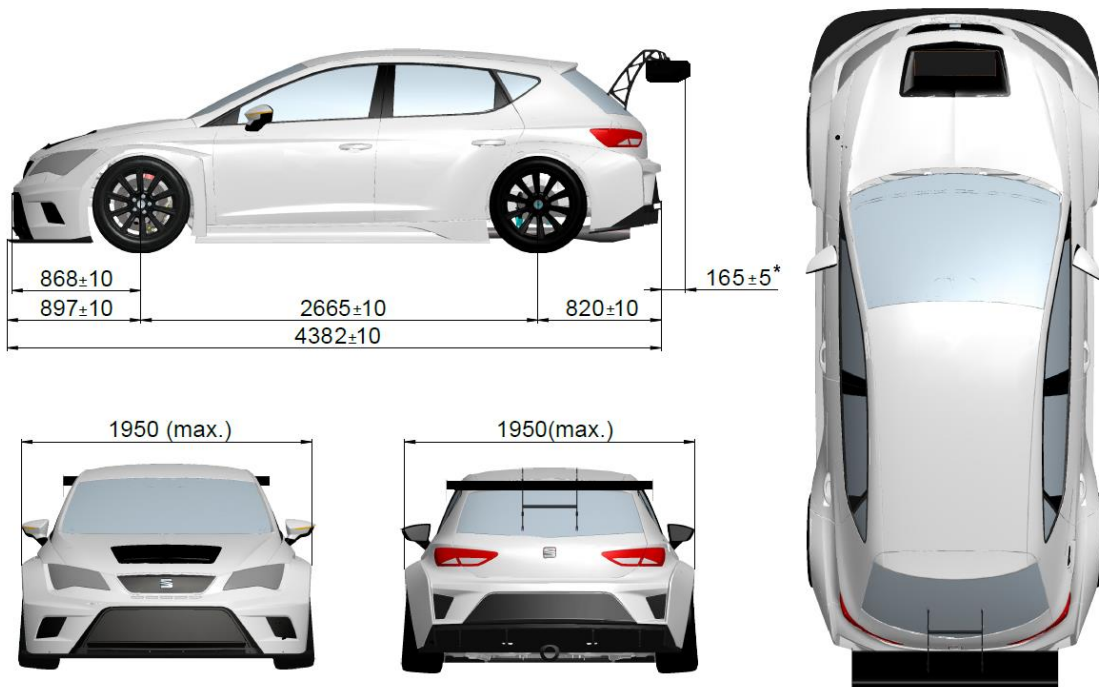

Weight	Measurements
Total weight in race conditions without fuel	1150 kg (1)
Car balance	63,2% front <-> 36,8% rear
Distribution weight/power	3,48 kg/hp

Note:

- (1) This value means the minimum weight on the "Technical Regulations" in race conditions.

1.3 Body shell

Part number	Description	Material
01	Bonnet	Steel
02	Left / right front bonnet	Steel
03	Left / right rear bonnet	Steel
04	Roof	Steel
05	Luggage compartment cover	Steel
11	Bonnet opening	Carbon
12	Front splitter	Carbon
13	Fender air exit	Carbon
14	Front bumper	Fiberglass
15	Rear bumper	Fiberglass
16 (2014)	Left / right sill trim panel	Plastic
16 (2015)	Left / right sill trim panel	Fiberglass
17	Left / right rear door extension	Carbon (painted)
18	Left / right rear fender extension	Carbon (painted)
19	Left / right front fender	Carbon (painted)
21	Windscreen	Glass
22	Left / right front door window	Glass
23	Left / right rear door window	Glass
24	Left / right rear triangle window	Plastic
25	Rear window	Plastic

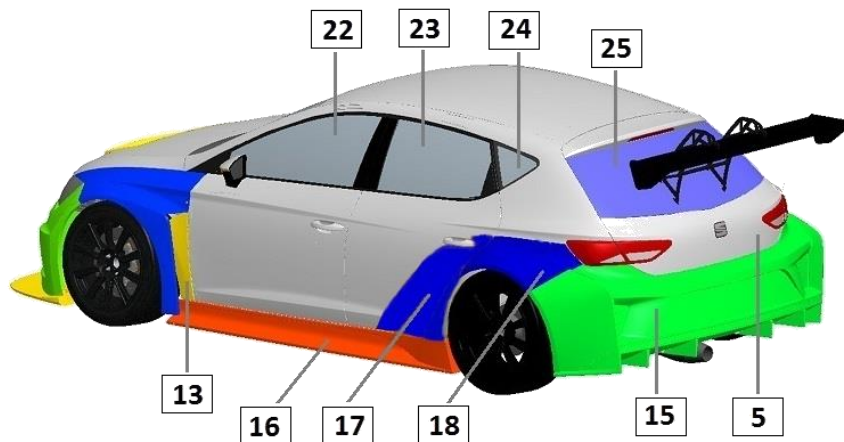
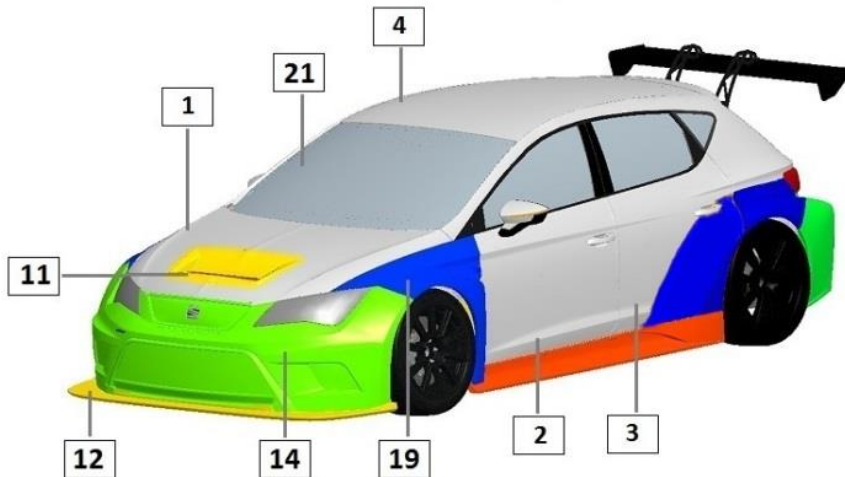

## 1.4 Powertrain

### Engine

Engine features	Description
Type	2,0 TSI / Turbocharged & direct injection
Engine identification	CJX
Cylinder capacity	1984 cc
Corrected cylinder capacity	1984 x 1,7 = 3372,8
Maximum power	242 KW (330 Hp) at 6250rpm
Maximum torque (Nm/ rpm)	410 Nm at 4600 rpm
Max rpm	6800 rpm
Specific Power	165 CV/l
Electronic control unit	CONTINENTAL SIMOS 18.1
Fuel	RON MIN 98 / RON MAX 102
Fuel Consumption	0,37 to 0,42 l/km
Exhaust / dB	Racing Catalyst FIA Homologated / 104 dB
Distribution	Chain (sealed)
Oil system	Wet sump
Water pump	One electric water pump + two auxiliary pumps
Water thermostat	Double electronic thermostat
Fan range	Operating range 92°C to 87°C

### Fuel tank

Fuel tank features	Description
Fuel tank type	Standard fuel tank from Quattro version
Capacity	55 l Standard tank
Minimum fuel level before engine fault	>5 l

### Engine power and torque curve:

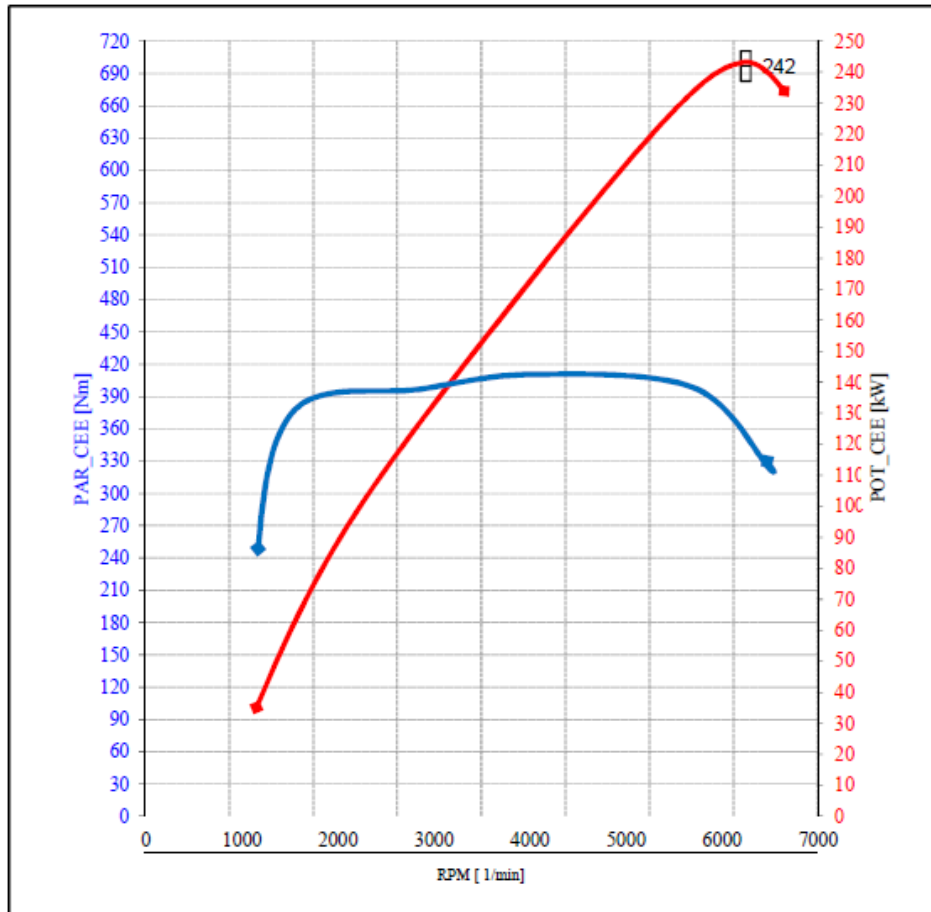



## Gear box & Slip diff.

Gear box features	Description
<b>Transmission</b>	Front wheel drive
<b>Gearbox</b>	6 speed DSG (semi-automatic gearbox)
<b>Differential</b>	VAQ Electronic slip differential
<b>Differential settings</b>	3 Map available. Map swapping through the steering wheel module green button.
<b>MAP 1</b>	Base mode: no overslip, only yaw damping in speeds above 110km/h. 300 Nm preload during braking. <b>Recommended use when grip is high (new tyres).</b>
<b>MAP 2</b>	Like map 1, less yaw damping, 200 Nm preload during braking. <b>Recommended use when medium grip (used tyres).</b>
<b>MAP 3</b>	Preload dependent from engine torque, 200 Nm preload during braking (releasing earlier than 2). <b>Recommended use when grip is low or rain</b>
<b>Clutch</b>	Double multidisc clutch in oil bath
<b>Gear box mode command</b>	Electronic on the central gear lever
<b>Gear shift</b>	Paddles on the steering wheel
<b>Gearbox Electronic Control Unit</b>	Integrated mechatronic in oil bath
<b>Cooling system</b>	Exchanger oil-water
<b>Launch control system</b>	Activated
<b>Down shift over rev protection</b>	Activated / 1sec memory

Gear box Ratios									
GROUP 1-2-3-4	15	72	0,208			83	180	189	DIF Km/h
GROUP 5-6	20	72	0,278		RPM1	GEAR SHIFT	CUT		
FINAL RATIO	1	1	1,000						
GEAR	Prim Z1	Sec Z2	Gear Relation	Total Relation	3000	6500	6800	DIF RPM	
1st	13	38	0,342	0,071	26	56	58		
2nd	22	45	0,489	0,102	37	80	83	1952	
3rd	28	41	0,683	0,142	51	111	117	1847	
4th	38	41	0,927	0,193	70	151	158	1711	
5th	32	35	0,914	0,254	92	199	208	1558	
6th	38	35	1,086	0,302	109	236	247	1026	

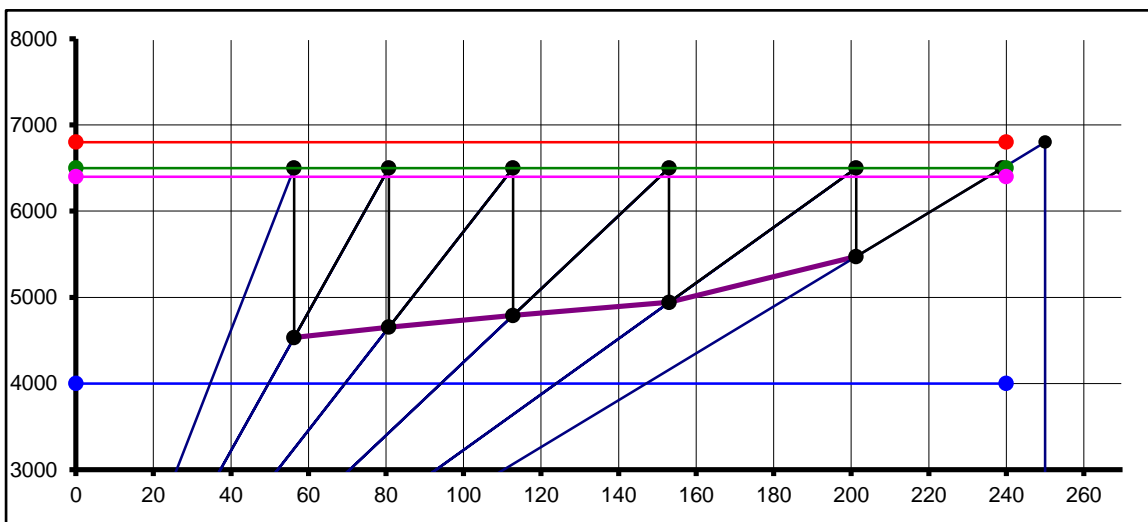

## Suspension

Features	Description	Remarks
Front damper ZF Sachs	2 way adjustable / Aluminium body	Clicks: bump 10 / rebound 20
Eibach springs front and rear	160/60/70-80-90-100-110	Adjustable
Front antiroll-bar	22x2 // 22x3	Adjustable in 6 positions
Rear bumper ZF Sachs	1 way adjustable / Aluminium body	Clicks: 20 bump/rebound
Rear antiroll-bar	22x3 // 22x4	

## Brakes

Brake car features	Description	Remarks
Front calliper	AP 6P	Special: SEAT Sport
Front disc	362 x 32	Special: SEAT Sport
Front pump	AP 19,1 mm	
Front pads	Pagid 5F6	Thick: 25 mm
Rear calliper	AP 2P	
Rear disc	272x10	Solid
Rear pump	AP 22,2 mm	
Rear pads	Pagid 5F6	Orange
Rear press reducer	Pressure limiting valve <b>25 bar</b>	Nominal
Brake balance	Mechanical	

## 1.5 Rim & Tire

Tyre information	Description
Rim dimension	10"x18" ET 36
Rim centre lock	5 studs x 112 mm
Maximum tyre dimension recommended	270/660 R18
Tyre temp difference inside/outside	20°C
Minimum cold pressure recommended	1.4 bar

## 1.6 Electronic units

Electronic MODULES	Remarks	Software	Place
ECU	Continental	Motorsport	Engine bay
Mechatronic	VW	Motorsport	Inside gear box
Electronic slip differential	BorgWarner	Motorsport	FDX (external)
Low fuel pump control	PWM control module	Series	Fuel tank (external)
Electronic steering rack	VW	Motorsport	Front subframe
ESP unit	Continental	Not active	Cockpit
Gateway	VW	Series adapted	Cockpit
Black box	Audi	Motorsport	Cockpit
MXG display/logger	AIM	Motorsport	Cockpit
Fuse box	SEAT Sport	Motorsport	Cockpit
Steering driver module	SEAT Sport	Motorsport	Cockpit
Transponder			Engine bay

## Modules information

Modules based in series	Engine	Mechatronic	Elec. slip diff.	Low fuel pump	Steering rack	ESP	Gateway
Specific software/mapping:	Yes	Yes	Yes	No	Yes	No	Yes
Specific codifications:	Yes	Yes	Yes	No	Yes	Yes	Yes
Interchangeable between cars:	<b>Yes</b>	<b>No</b>	<b>No</b>	<b>Yes</b>	<b>Yes</b>	<b>Yes</b>	<b>Yes</b>
Spare part ready for plug and play:	Yes	No	Yes	Yes	Yes	Yes	Yes
*UDS diagnosis (VW diagnosis):	Yes	Yes	Yes	Yes	Yes	Yes	Yes
<b>Modification allowed:</b>	<b>No</b>	<b>No</b>	<b>No</b>	<b>No</b>	<b>No</b>	<b>No</b>	<b>No</b>

**Notes:**

- Use always spare parts from SEAT Sport. Although the mentioned parts are derived from series cars, the software and codifications are different and modified for SEAT Sport.
- OBD: All series modules used on the SEAT Leon Cup Racer are based in the MQB platform. Through the diagnostic tool available on the VW Group dealers, it is possible to diagnostic any malfunction.

Architecture Leon Cup Racer

All electronic modules are connected by CAN Bus and LIN\_Bus. Following the LCR CAN scheme view:

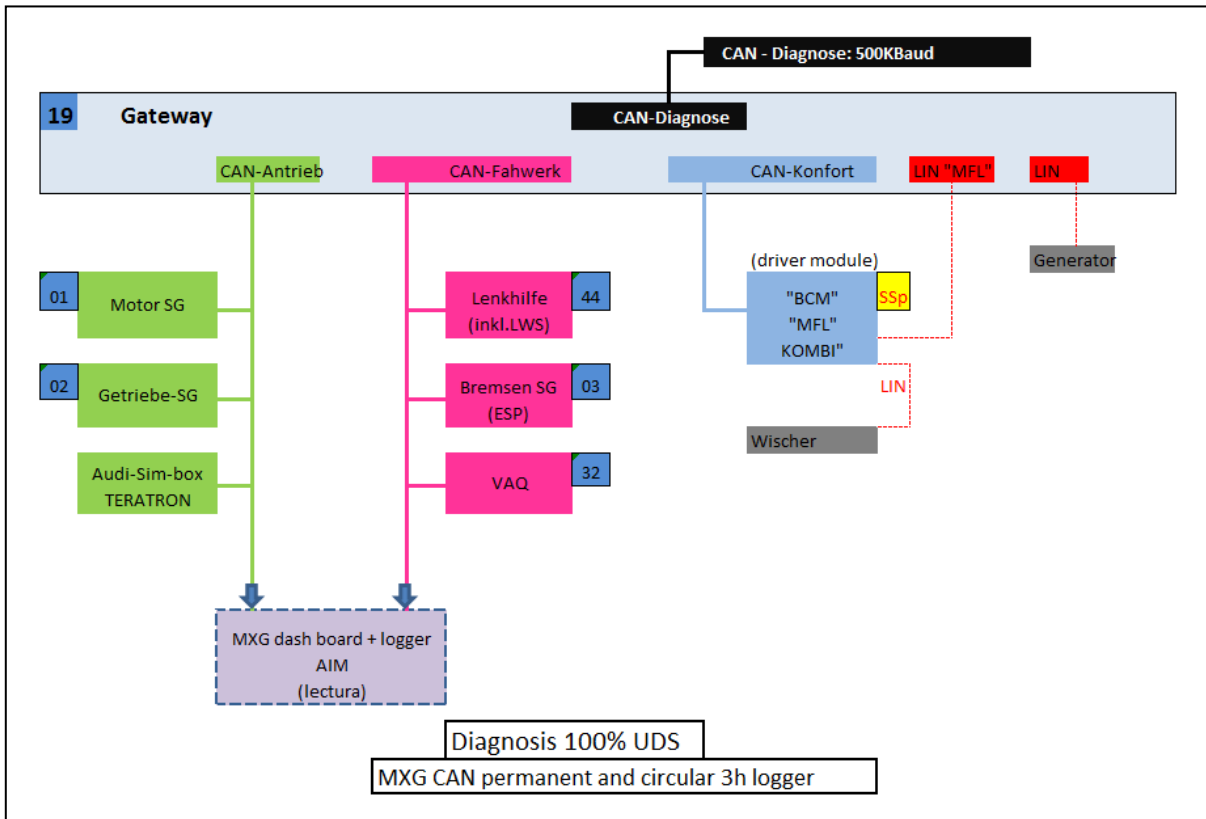

## 2 DRIVERS CONTROL

In this section is explained how the driver can handle the Leon Cup Racer commands and functions.

### 2.1 Main console

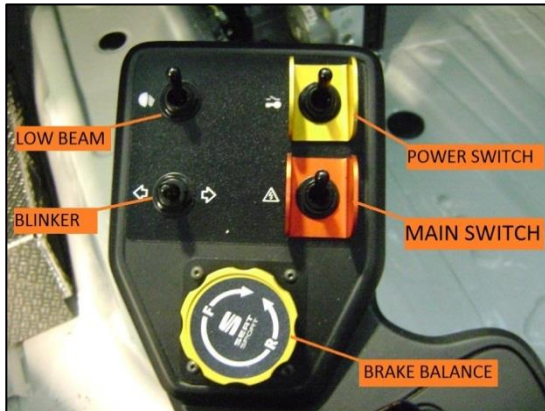

**Main switch:** Activates the battery supply.

**Power switch:** Activates the power to all devices.

**Low beam:** Activates low beam light. High beam and flash activation buttons are placed on the steering wheel module.

**Blinker:** Activates the left and right turn lights. No automatic return.

**Brake balance:** Turning the balance wheel you can balance the brake pressure from front to back or vice versa.

Do not press the brake pedal while moving the balance wheel.

Through the driver display you can check the front and rear brake pressure and the balance in percentage.

**Note:**

- To start the engine, always proceed with this order: Main switch and later power supply. To stop the engine proceeds backwards.









### 2.2 Steering wheel module





The electronic steering wheel module permits to activate different functions without removing hands from the steering wheel.

Some buttons have double functionality.



Steering wheel functions:

Nº	Function	Conditions / Remarks
1	 <b>Starter</b>	Active in gear lever in "P" or "N" Active if rpm < 500
	 <b>Speed limiter</b>	Pressing the button constant limit 60 km/h
2	 <b>Diff map change 3 maps</b>	Short push to increase differential map number The diff map scrolls rotatory with 3 maps Diff map number is showed on the display screen "driver 1" <b>Map 1: Use when grip is high (new tyres or good grip)</b> <b>Map 2: Use when medium grip (used tyres)</b> <b>Map 3: Use when grip is low or rain</b>
3	 <b>Safety brake signal button</b>	Brake signal can be activated with this button in case of brake switch failure Makes possible to move the gear lever without pushing the brake pedal <b>IMPORTANT:</b> the use of this security button is under user's responsibility
4	 <b>Radio</b>	Driver voice activation Maintain pushed to talk
5	 <b>Rain lights</b>	Short push to toggle on/off
6	 <b>Driver fan</b>	Toggle to activate
7	 <b>Change display</b>	Press to change the display pages / rolling change

8		<b>High beam</b>	Short push to flash Long push to toggle on/off
9		<b>Wiper</b>	Toggle to activate
10		<b>Windscreen water</b>	Push to activate water splash + wiper activation
11		<b>Drink</b>	Activates water pump Note: Pump not supplied by SSp
-- +		<b>Tip up // Tip down</b>	Orange led informs when tip up or down signal has been activated
		<b>CAN info</b>	Usual status: LED off LED on when there is a problem of CAN Bus communication

### Notes:

- Although it is possible to uncouple completely the steering wheel from the column with the engine running, is not advisable (causes fault messages on the OBD).
- Be careful with the “Safety brake signal button”. This button permits putting in Neutral the gear lever although the brake pedal is not pressed. Take care and advise the people around the car because wheels may move.

## 2.3 Display alarms and shift lights

### Car delivery alarm configuration

Gear	Shift Light 1	2	3	4	5	6	7	8	9	10	
All	6100	6100	6100	6300	6300	6300	6400	6450	6500	6600	

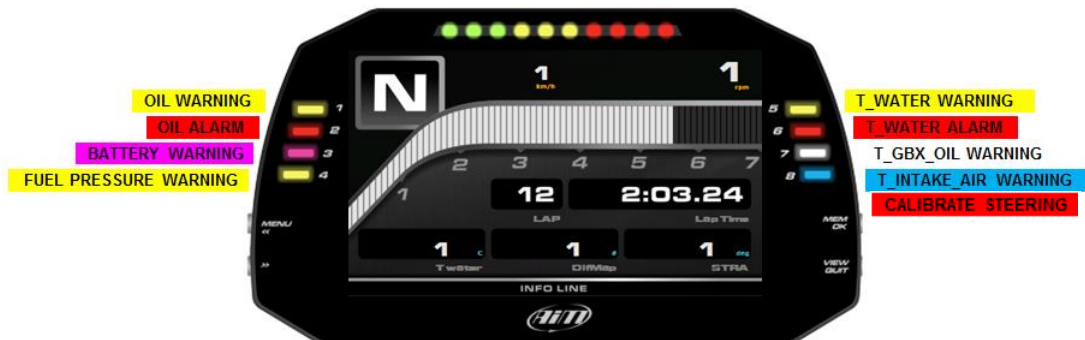

### Notes:

- **LED 1 yellow alarm light:** Low oil pressure. If no red alarm follows you can continue. If alarm disappears you can continue pushing. Check the oil level when back into the pit.
- **LED 2 red alarm light + POP UP:** Very low oil pressure. Big risk to break the turbo or to damage the engine. Seat Sport recommends slowing down and entering to the pit-lane or stopping in a safe place.
- **LED 3 purple alarm light:** Battery voltage low warning. You can continue, check the alternator and the alternator poly-V belt.
- **LED 4 yellow alarm light:** Fuel pressure low warning. You can continue, check the fuel level.
- **LED 5 yellow alarm light:** water temperature high. Pay attention, drive out of slipstream and keep an eye on the values. If no red alarm follows you can continue. If alarm disappears you can continue pushing.
- **LED 6 red alarm light:** water temperature too high. Drive out of slipstream and keep an eye on the values. Some torque reductions will appear but you can continue.
- **LED 6 red alarm + POP-UP message:** Critical water temperature. Seat Sport recommends slowing down and entering to the pit-lane or stopping in a safe place, to avoid damaging the engine.
- **LED 7 white alarm light:** Gearbox oil temperature high. Drive out of slipstream and keep an eye on the values if not some torque reductions will appear. You can continue.
- **LED 8 blue alarm light:** Intake air temperature high. Drive out of slipstream and keep an eye on the values if not some torque reductions will appear. You can continue.

- **LED 8 red alarm light:** Steering initialization needed (it will appear each time the car is switched on). Turning the steering wheel left and right should disappear. If not, there is a problem in the electrical steering rack.



	<input checked="" type="checkbox"/> Events	Alarms						
↑ priority	<input checked="" type="checkbox"/>	ALRM Oil_Pressure 2	LED: 2		Output:	Message:		
	<input checked="" type="checkbox"/>	ALARM Oil_Pressure	LED: 1		Output:	Message: Low Oil Pressure		
	<input checked="" type="checkbox"/>	Oil Pressure_Popup	LED:		Output:	Popup Message: OIL PRESSURE		
	<input checked="" type="checkbox"/>	ALARM Fuel_Pressure	LED: 4		Output:	Message: FUEL PRESSURE LOW		
	<input checked="" type="checkbox"/>	WATER TEMP POPUP	LED:		Output:	Popup Message: CRITICAL WATER		
	<input checked="" type="checkbox"/>	ALARM T_Water_2	LED: 6		Output:	Message: WATER TEMP TOO HIGH		
	<input checked="" type="checkbox"/>	ALARM T_Water	LED: 5		Output:	Message: WATER TEMP HIGH		
	<input checked="" type="checkbox"/>	ALARM Gearbox_Temp	LED: 7		Output:	Message: GEARBOX TEMP HIGH		
	<input checked="" type="checkbox"/>	ALARM Air Temp	LED: 8		Output:	Message: AIR TEMPERATURE HIGH		
	<input checked="" type="checkbox"/>	ALARM Battery	LED: 3		Output:	Message: Bat Voltage Low		
	<input checked="" type="checkbox"/>	Steering Wheel pos	LED: 8		Output:	Message: Steering Wheel Pos		



## 2.4 Gear lever functions

The shifting gear lever enables the different gear box modes. The features for each mode are:

Gear lever	Mode	Remarks
		
<b>P</b>	<b>Parking mode</b>	Use to lock the car. (Safety for team staff when car is stopped)
<b>R</b>	<b>Reverse</b>	Not allowed on the pits zone
<b>N</b>	<b>Neutral</b>	No gear engaged. Traction is free.
<b>D/S</b>	<b>Automatic mode</b>	D: Automatic Drive S: Automatic Sport Drive
<b>Tip + / - (TS)</b>	<b>Manual shifting</b>	Shifting through the wheel paddles

### “P” parking mode:

Use parking mode to lock the transmission through a mechanical cable. Use only this position when you want to block the car.

- It's only possible to lock or unlock the parking mode if the car is completely stopped and the brake pedal is pressed.
- **IMPORTANT: Never try to put the gear lever in “P” if the car is not completely stopped. If this happens the gear box might be seriously damaged.**
- If for any reason it is not possible to move the lever from “P” position although you are pressing the brake pedal, through the safety grey button “sign (P)” on the steering wheel module it is possible to unlock the gear lever command.

### “R” reverse mode:

- It's only possible to put on and take out the “R” (reverse) mode if the car is completely stopped and the brake pedal is pressed.

### “N” neutral mode:

- In “N” mode, it is possible to move the car pushing externally (pit lane use).

### “D” automatic mode:

- Not advisable for race. “D” mode is only advisable to move the car on the paddock zone. The gear shifting is working in a low range of engine speed.

### “S” automatic mode:

- Pushing the gear lever backward one time when lever is in “D” the **“S” mode will be engaged**. Driver display will show now “S”. (left up corner)
- Use “S” mode to drive in automatic shifting. Simultaneously it is possible to use the steering paddles.
- It's possible to use “S” mode in the launching system. The gear will shift up automatically. The driver can pass to Tip mode in any moment.
- It's possible to pass from “D” or “S” to Tip and backwards always and in any moment.

### “Tip” manual mode: “TS” (the most advisable for motorsport)

- From the “S” or “D” gear lever position move the gear lever to the right side. Driver display will show **“TS” mode**.

- Use "TS" mode for drive in manual mode, handling the shifting by the steering paddles.
- In "TS" the shifting is manual. When the engine reaches rpm limit (6800 rpm) the power is limited.
- Downshifting is protected preventing the engine from overrevs. Shift demand will be active for one second.

## 2.5 Standing start procedures

There are two ways to manage the standing starts, manual or automatic procedures.

### **"LCS" LAUNCH CONTROL SYSTEM -AUTOMATIC-**

LCS allows you to perform a semiautomatic car launching. This system is automatically activated if wheels are absolutely stopped and brake pedal is pressed.

Launching time after brake signal pedal off:

#### **Process:**

1. After the grid formation lap, stop completely the car on the grid line pushing the brake pedal.
2. Gear lever has to be in "S" or "TS" mode. If this mode was already in during formation lap, will not be necessary move the gear lever.
3. Push gas pedal flat out. Engine will limit at 4200 rpm approximately.
4. Release the brake pedal and car will be launched. Driver has to control the wheel spin with the gas pedal.

**Summarizing:** Arriving from the formation lap driving in "S" or "TS" stops the car on the grid line pressing the brake pedal. Push the foot throttle flat out (4200rpm) and release the brake pedal when you decide (max time 6 sec flat out).

Control the wheel spin releasing the gas pedal and enjoy.

#### **Notes:**

- *To start in "S" is necessary to release a little bit the gas pedal from full to disable the launch system. After this, using the "S" mode, up shift is automatic.*
- *Is possible to use the Launch Control System controlling the rpm. Advisable no bellow of 3500 rpm.*
- *The system needs brake pressure >10 bar. Push the brake pedal clearly.*
- *With Red starting lights: If you release just a little bit the brake pedal in any moment of the system process will understand that launch is done and the clutch will load irreversibly.*

### **MANUAL SYSTEM**

It's possible to carry out a manual standing start with the same success.

#### **Process:**

1. After the grid formation lap, stop completely the car on the grid line.
2. Push the brake pedal (Brake press >5 bar)
3. Gear lever has to be in "S" or "TS" mode. If this mode was already in, it's not necessary move the gear lever.
4. Release the brake pedal while you press down the gas pedal.

#### **Note:**

- *It's also possible to put load at the engine accelerating a little bit while you are braking. Take care with the time you are loading the engine because the clutches take temperature very fast and after a certain limit the clutch launch is coming slow. Recommendation not more than 3 seconds.*

## 2.6 Speed limiter system

The speed limiter system allows limiting the car speed. This system is recommended for the pit lane area.

Speed limiter limitation is 60Km/h (tolerance - 2 km/h GPS speed)

#### **Process:**



1. Brake to reduce the car speed around 60 km/h or little less.
2. Release the brake and press the steering wheel red button as long as you want it to act.
3. Push the gas pedal fully. Car speed has to be limited.

**Notes:**

- Can be applied in different gears. Recommended 3<sup>rd</sup> or 4<sup>th</sup> gear.
- Is not recommended to activate it in the track, when safety car or others.

**2.7 Driver has to consider**

- Learning and memorizing the steering wheel buttons place and functions will allow drivers a faster action and will help to not lose reference points on the track.
- Warm up the engine before starting. The minimum water temperature before to load the engine is 80°C.
- Checking the brake pedal is hard when car is stopped and on the acceleration way.
- Warm up the tires before attacking. Without blankets use, the rear tires takes 2 laps to warm and this car is very sensitive on that.
- Shift up the gear when shift light indicates. The recommended shifting is around 6300 rpm.
- Shift down gears without stress. Automatic gearbox needs to reduce engine rpm to permit the next shifting down. Do not shift down 3 times consecutively if the previous gear was not engaged (memory active for 1 sec).
- Last lap: Cool down brakes and engine water to avoid the engine and discs thermal shock.
- Display alarms: There are three different possibilities to show alarms, 1) LEDs lateral, 2) red ribbon bellow screen 3) completely screen pop up message. Stop the engine if "pop up" message appears (Oil or water). It is possible to modify the display alarms configuration.
- If for any reason you have to drop out the car on the track put the gear lever in "N" Neutral to save the transmission in case of being towed.
- It is important to bed discs as follows to get the maximum life:
  - When possible bed discs with used pads.
  - To reduce thermal shock during bedding, the brake ducts may be 50% taped off.
  - Apply the brakes gently at low speed a few times to ensure correct installation.
  - Apply the brakes moderately, (progressively up to 50% race speed, 25% race pressure), for 10-20 applications to ensure above 80% pads face contact with disc. The contact with the disc face is particularly important at the inner swept area. The first time a driver gets used to bedding discs on a car it is worthwhile getting him to return to the pits to check contact is sufficient before preceding to the next step.
  - Progressively build up to about 70% of race speed and 50% of race pressure. Then, apply brakes for approximately 25 applications.
  - Perform one lap cooling down before returning to the pits.
  - The orange temperature paint should be turned on the surface and the green 75% of the way through the disc thickness at which point any tape can be removed. On returning to the track progressively come up to race speed and pressure.

## 3 DISPLAY & FUSE BOX

MXG is the new AIM dash-logger designed to acquire and display data coming from your ECU, the internal accelerometer and gyro, as well as from the GPS module, analog/digital inputs and predefined math channels. Performance and data acquired can also be incremented adding expansion modules.

It's possible to scroll the pages using steering wheel module's black button (7).

To enable "the lap time" is necessary to insert the track where you are running. Track load has to be done by the program GPS Manager available at the RaceStudio3 software.

SmartyCam: The on-board cameras that overlays on videos the data sampled by your logger.

Software RaceStudio3, Firmware MXG and documentation available on the AIM web site:

<http://www.aim-sportline.com/eng/download/index.htm>

Display logger user guide available on the AIM web site:

[http://www.aim-sportline.com/download/doc/eng/mxs-mxg/MXG\\_user\\_guide\\_101.pdf](http://www.aim-sportline.com/download/doc/eng/mxs-mxg/MXG_user_guide_101.pdf)

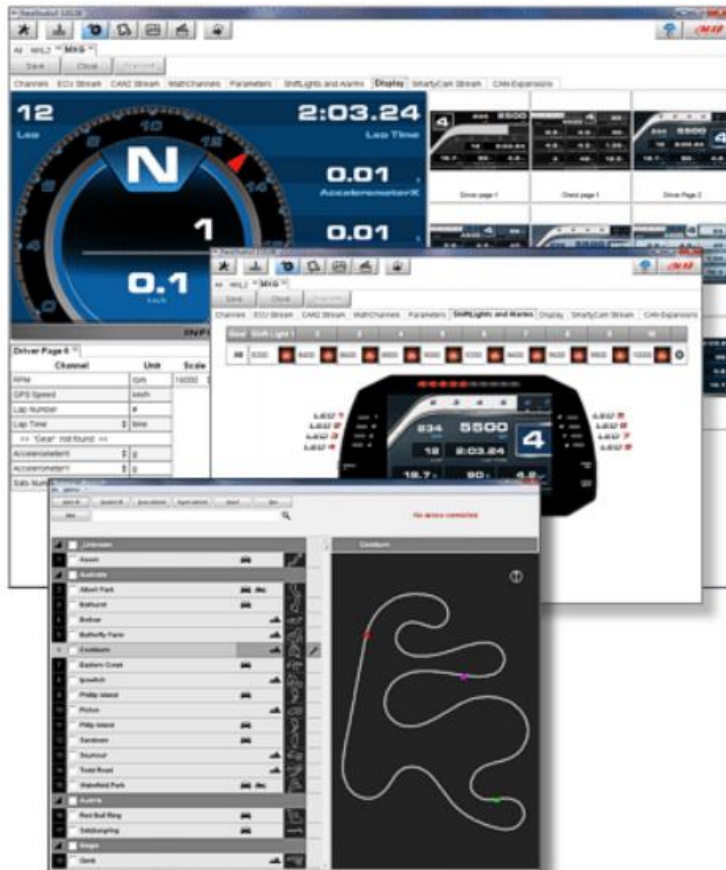

## 3.1 Display alarms and shift lights

Eight configurable RGB alarm LEDs, combined with lower red bar alarm and red pop up alarm. Select solid alarm or flashing one – and the flashing frequency, choose to have an accompanying text message and set the alarm priorities.

### Alarms and shift lights

**1**

MXG features 10 RGB gear flash LEDs that can be freely configured in a very flexible way. For every LED, you can define the RPM

value at which to turn it on and the colour. You can also define different RPM values per every gear number.



**2**

MXG also has 8 different alarm LEDs that you can configure in order to turn them on or off depending on the value of the analog or digital inputs, ECU values, expansion values, GPS information or math channels.

You can configure them in order to turn them off when the condition disappears, when you push a pushbutton, when the test is finished or when the data are downloaded after the test.

You can associate an alarm LED, a message and a digital output with every event.

Please, read section 10.1.4 in order to see how to manage gear flashes and alarm LEDs.

 **IMPORTANT: the change of the alarms or shift lights is under user responsibility.**

## 3.2 Data acquisition analysis

MXG logger **data acquisition** channels information:

Data acq name	Description	Unit	Recommended scale
P_TURBO	Boost pressure	Pressure (bar)	0 ... 3
T_ENG_AIR	Intake air temperature	Temperature (°C)	20 ... 70
T_ENG_OIL	Engine oil temperature	Temperature (°C)	80 ... 150
T_ENG_WATER	Water temperature	Temperature (°C)	70 ... 125
T_AIR	External air temperature	Temperature (°C)	12 ... 45
RPM_ENG	Engine speed	rpm	1000 ... 7000
FLAG_BRAKE	Brake lights	on/off	0 / 1 (1= braking)
P_BRK_FRONT	Front brake pressure	Pressure (bar)	0 ... 100
P_BRK_REAR	Rear brake pressure	Pressure (bar)	0 ... 100
P_ENG_OIL	Engine oil pressure	Pressure (bar)	1,5 ... 5
P_ENG_FUEL	Engine fuel low pressure	Pressure (bar)	0 ... 7
FUEL_LEVEL	Fuel level	Amount (litres)	0 ... 55
POS_PEDAL	Gas pedal position	Load (%)	0 ... 100
POS_GBX_LEVER	Gearbox lever position	Number	0=Init, 5=D, 6=N, 7=R, 8=P, 10=Tip+, 11=Tip-, 12=S, 14=Tip Pos, 15=Failure
POS_GBX	DSG mode	Number	0=Init, 5=P, 6=R, 7=N, 8=D, 9=S, 13=TD, 14=TS, 15=Failure
GEAR	Gear	Number	0=N/P, 1=1 <sup>a</sup> , 2=2 <sup>o</sup> , 3=3 <sup>o</sup> , 4=4 <sup>o</sup> , 5=5 <sup>o</sup> , 6=6 <sup>o</sup> , 8=R
TIP_DOWN	Tip down	Sign	0 / 1 (1=Tip down)
TIP_UP	Tip up	Sign	0 / 1 (1=Tip up)
POS_DIF_MAP	Differential map	Number	1 - 2 - 3
I_DIF_PUMP	Diff pump current consumption	Current (A)	1 ... 12
TORQ_DIF_REF	Diff reference torque	Torque (Nm)	50 ... 2000
T_GBX_OIL	Gearbox oil temperature	Temperature (°C)	90 ... 150
G_CH_Y	Lateral acceleration (ESP)	Acceleration (g)	-2,5 ... 2,5
G_CH_X	Longitudinal acceleration (ESP)	Acceleration (g)	-1,6 ... 1,6
W_CH	Yaw rate	Angular speed (°/s)	-50 ... 50
V_WHL_RL	RL wheel speed	Velocity (km/h)	0 ... 260
V_WHL_RR	RR wheel speed	Velocity (km/h)	0 ... 260
V_WHL_FL	FL wheel speed	Velocity (km/h)	0 ... 260
V_WHL_FR	FR wheel speed	Velocity (km/h)	0 ... 260
V_WHL_REF	ESP reference speed	Velocity (km/h)	0 ... 260
A_STE	Steering angle	Angle (°)	-200 ... 200
FLAG_FBX_F5	Fuse state 5	Number	0 ... 8
FLAG_FBX_F4	Fuse state 4	Number	0 ... 8
FLAG_FBX_F3	Fuse state 3	Number	0 ... 8
FLAG_FBX_F2	Fuse state 2	Number	0 ... 8
FLAG_FBX_F1	Fuse state 1	Number	0 ... 8

<b>I_FBX_MAIN</b>	Fusebox electrical current	Current (A)	10 ... 40
<b>Battery Voltage</b>	Battery Voltage	Voltage (V)	11 – 14,5

AIM GPS Channel	Unit	Description
GPS_Speed	km/h	
GPS_Nsat	Number	Nº of satellites
GPS_LatACC	g	
GPS_LonACC	g	
GPS_Slope	º	
GPS_Heading	º	
GPS_Gyro	º/s	
GPS_Altitude	m	

Following, the values shown are the standard approximate values at **20°C** air temperature.

Channel measures	Idle speed*	Standard values at T <sub>air</sub> 20°C	Maximum value**
<b>P_TURBO</b>	0 bar	2.35 bar ***	2.99 bar
<b>P_ENG_FUEL</b>	4.1 bar	5.8 bar	7 bar
<b>P_ENG_OIL</b>	2 bar	4 bar	5 bar
<b>T_ENG_AIR</b>	40°C	42°C	>85°C
<b>T_ENG_OIL</b>	80°C	122°C	>150°C
<b>T_ENG_WATER</b>	90°C	95°C	>115°C
<b>T_GBX_OIL</b>	40°C	114°C	>142°C

**Notes:**

- \* These values can change depending on car's engine temperature. Those are approximate values when T<sub>water</sub> is 90°C after having warmed the car from cold always in idle speed.
- \*\* The maximum value underlined in orange shows the value before performance restrictions or protection.
- \*\*\* The boost pressure did not change from 2014 to 2015 cars. The diagnosis value shown in 2014 cars was limited at 2.2 bar. 2015 cars will show the direct value.

### 3.3 MXG channel expansion scheme

MXG logger data expansion channels:

Scheme 1: Data logger standard connection scheme (car delivery)

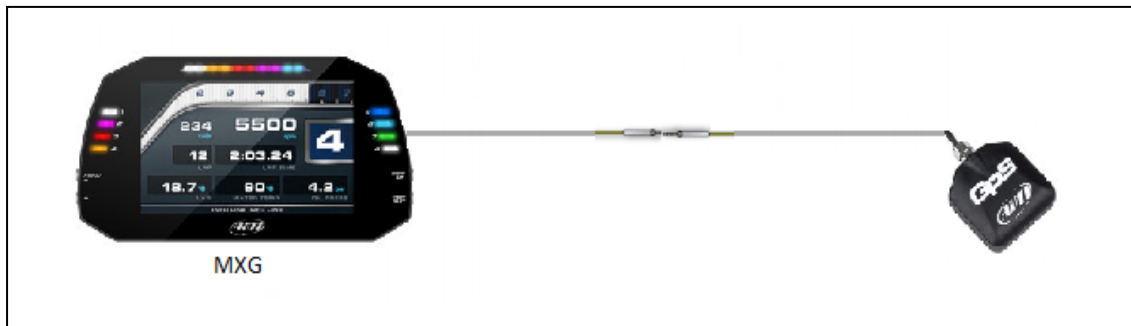

Scheme 2: Data logger connection scheme with Smarty cam and expansion module

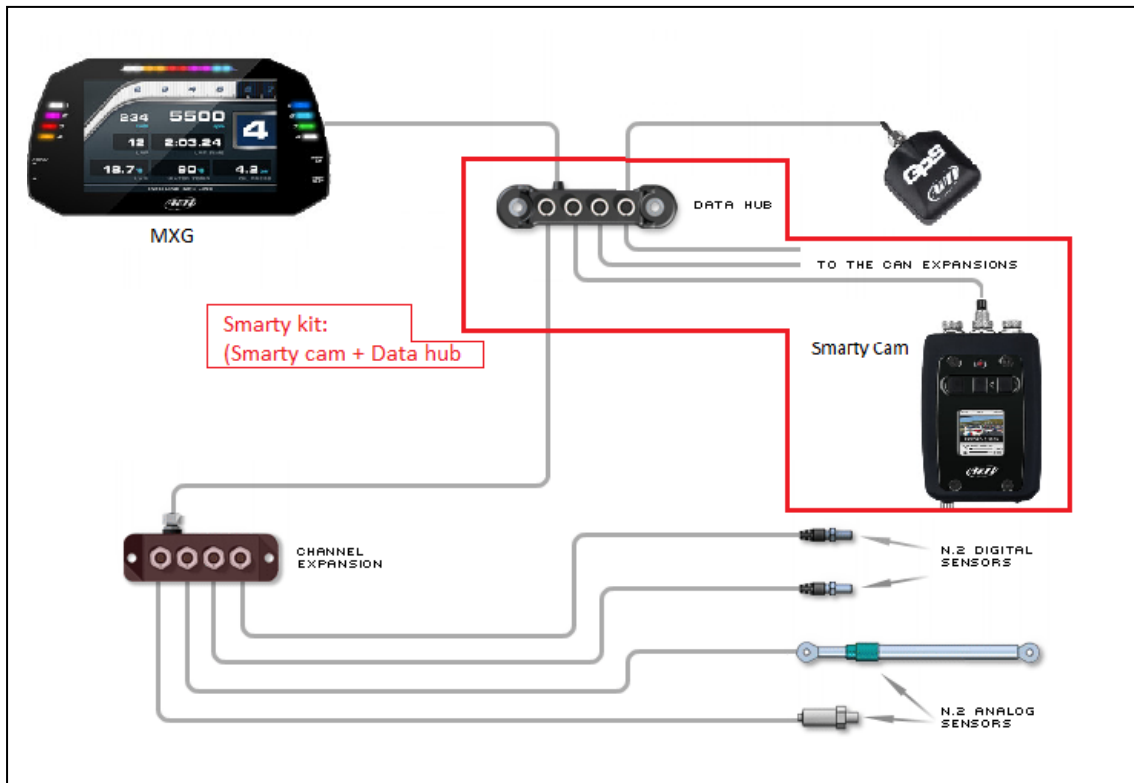

Features	Remarks
Beacon	The MXG system uses Only GPS signal.
Circuit config.	Through the "RaceStudio3" with/or "Track Manager" program is possible to activate all the circuits in the world. It is possible to create your own circuit with the program.
Extra sensors*	In case you want to add extra sensors, you have to connect them to an expansion module as shown in the scheme 2. Any extra sensor has to be connected through the AIM DATA HUB + CHANNEL EXPANSION (scheme 2)

**Notes:**

- For the SEAT Leon Eurocup participants: Any extra sensor has to be connected through AIM system.
- Channel expansion module and sensors are only available through AIM dealers.
- IMPORTANT: If for any reason it is necessary to send data acquisition files to SSp, you have to send the following data files extensions: .drk, .bak, .gpk,.rrk and .xrk

## 3.4 Fusebox

The Leon Cup Racer fusebox is an electronic box that controls the power supply to practically all devices. Internally the fuses are resettable automatically, so never is necessary to change a fuse. In case of malfunction has to be sent to SEAT Sport.

It is also possible to check the fuses activation in the fusebox, so you will know if the current or signal was sent.

There are three ways to check the correct functioning:

- Live measures view in RaceStudio3.
- Analysing the data in Race Studio Analysis.
- Checking the red LEDs on the fusebox.

If a malfunction is detected, it is necessary to control the corresponding wiring or the device.

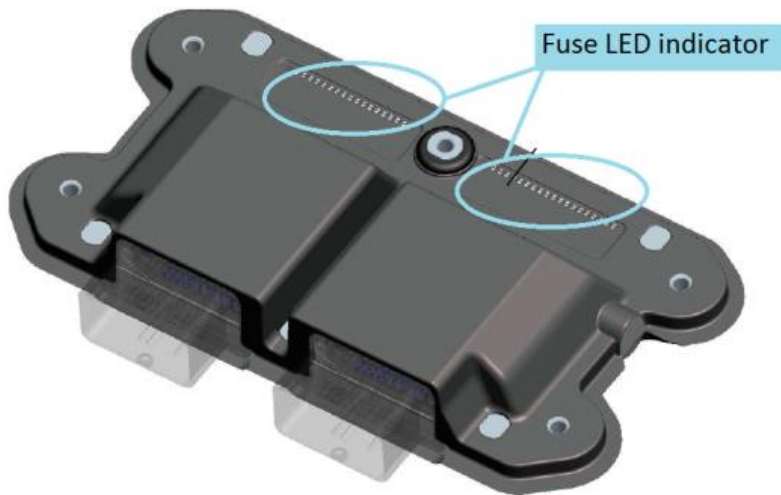

Fuse box LED label

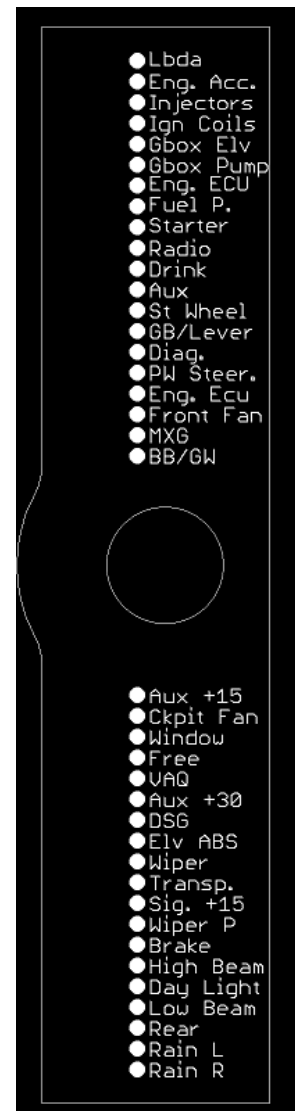

In the following table is shown the fuse analysis information:

- Channel name: There are 5 channels for analysis.
- Bite number: Each flag channel controls 8 fuses.
- Data value: Is the value you can check on the data acquisition.

Channel name	bit number	Data value	Description
FLAG_FBX_F5	bit8	-----8	Sadev pump
	bit7	-----7-	HR-ECU
	bit6	-----6--	HR-Fuel pump
	bit5	-----5---	Starter
	bit4	-----4----	Radio
	bit3	-----3-----	HR-Lambda
	bit2	-----2-----	HR-Miscellaneous
	bit1	-----1-----	HR-Injectors

FLAG_FBX_F4	bit8	-----8	MR-ignition coils
	bit7	-----7-	Sadev-ELV
	bit6	----6--	Drink
	bit5	---5---	Switch Panel / Aux. Data connector
	bit4	--4----	Steering Wheel
	bit3	-3-----	Gear Lever / GCU
	bit2	-2-----	Diagnosis Connector
FLAG_FBX_F3	bit1	1-----	Power steering ECU
	bit8	-----8	ECU
	bit7	-----7-	Front Fan
	bit6	----6--	MXG
	bit5	---5---	BlackBox / Gateway
	bit4	--4----	Differential
	bit3	-3-----	+30 Aux. connector
FLAG_FBX_F2	bit2	-2-----	DSG
	bit1	1-----	ABS ELV
	bit8	-----8	Wiper
	bit7	-----7-	Turn light
	bit6	----6--	Diagnosis Connector / +15 Aux con.
	bit5	---5---	Cockpit fan
	bit4	--4----	Window
FLAG_FBX_F1	bit3	-3-----	not used
	bit2	-2-----	Transponder
	bit1	1-----	+15 signal
	bit8	-----8	Wiper pump
	bit7	-----7-	Brake light
	bit6	----6--	High beam
	bit5	---5---	Day light
bit4	--4----	Low beam	
bit3	-3-----	Rear light	
bit2	-2-----	Rain light left	
bit1	1-----	Rain light right	

 **Example:** In the acquisition screenshot below is shown the channel “FLAG\_FBX\_1” in green. The value is “7” when braking and 0 when no braking. On this case the conclusion is that there is a problem on the brake light line.

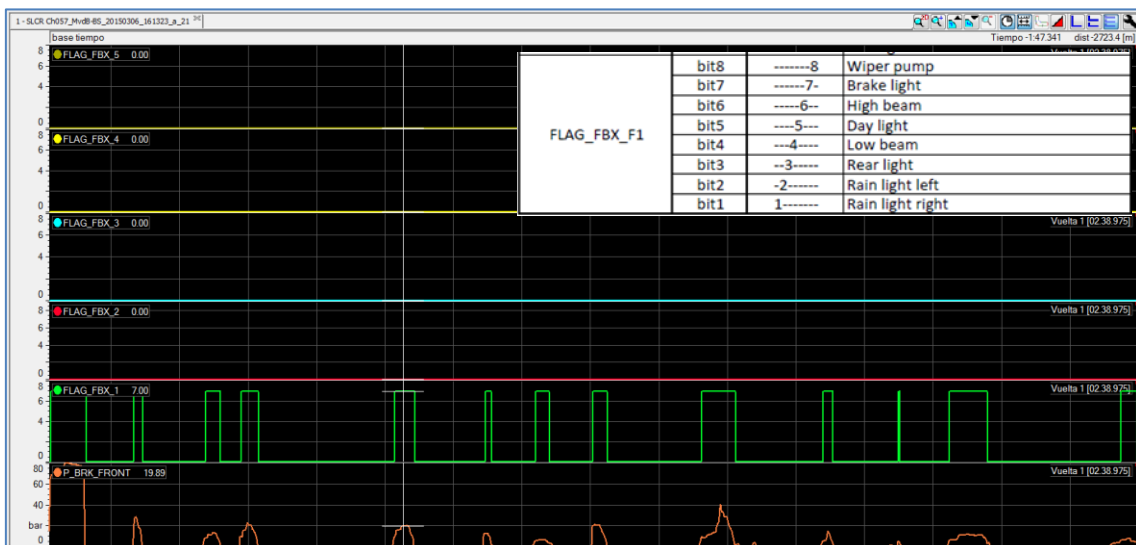



## 3.5 Auxiliary connectors

The main car wiring loom is prepared with some auxiliary connectors to make easier the connection of auxiliary devices.

### RADIO AND DRINK

Behind the driver seat there are two free connectors associated with the steering wheel module (radio and drink). Connecting here the radio and drink systems, both can be handled through the steering wheel module.

Radio connector		
<b>Main loom reference connector:</b>		4D0 972 704
<b>Matching connector:</b>		1J0 972 714
Pin out	Terminal	
1	+30 up to 8A	FS 2,8 x 0,8 (*)
2	GND	FS 2,8 x 0,8 (*)
3	PTT	FS 2,8 x 0,8 (*)
4	PTT	FS 2,8 x 0,8 (*)

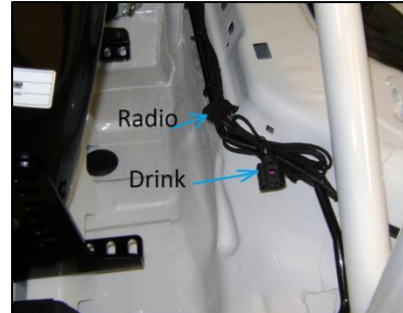

Drink connector		
<b>Matching connector:</b>		1J0 973 822
Pin out	Terminal	
1	up to 2.5A	
2	GND	

### FUEL CONSUMPTION DISPLAY AND TCR SCRUTINEERIG EVO4 LOGGER

This connector is placed in the driver cockpit above the central tunnel (front). Also could be used for other requirements.

Auxiliary power supply		
<b>Matching connector:</b>		191 972 733
Pin out	Terminal	
1	+30 up to 3A	FS 2,8 x 0,8 (*)
2	GND	FS 2,8 x 0,8 (*)
3	CAN H traction	FS 2,8 x 0,8 (*)
4	CAN L traction	FS 2,8 x 0,8 (*)
5	CAN H chassis	FS 2,8 x 0,8 (*)
6	CAN L chassis	FS 2,8 x 0,8 (*)



### TRANSPONDER

This auxiliary connector is placed NEXT to the right front headlight.

- All SEAT Leon Cup cars bought to participate on the SEAT Leon Eurocup will be provided with the transponder mounted.
- The cars bought for other championships will be provided without transponder.

Transponder	Remarks
Availability	All Eurocup participants have installed Rest: purchase order
Type	Radio frequency
Energy	Connected to the car 12V (with fuse)
Position	See drawing // right side // body shell support ready.

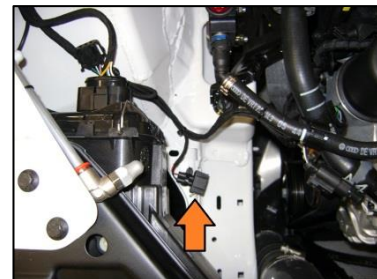

Transponder SEAT LEON EURO CUP		
<b>Matching connector:</b>		357 972 762
Pin out	Terminal	
1	12v	FS 2,8 x 0,8 (*)
2	GND	FS 2,8 x 0,8 (*)

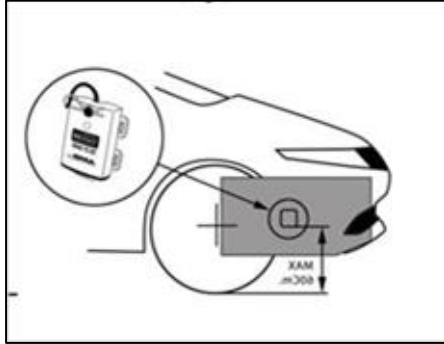

## AUXILIARY SERVICE CONNECTORS

These connectors are free when the car is new. They are placed on the cockpit bay, in the middle of the tunnel. See the following pictures:

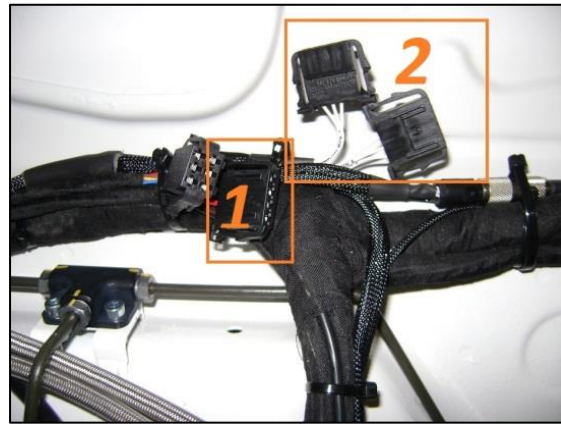
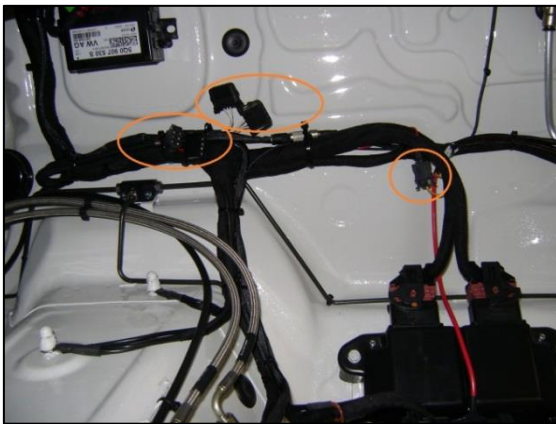

### 1 Additional power supply: (+15, +30, GND x2)

Additional power supply		
<b>Main loom reference connector:</b>		4D0 972 704
<b>Matching connector:</b>		1J0 972 714
<b>Pin out</b>		Terminal
1	+30 up to 8A	FS 2,8 x 0,8 (*)
2	+15 up to 5A	FS 2,8 x 0,8 (*)
3	GND	FS 2,8 x 0,8 (*)
4	GND	FS 2,8 x 0,8 (*)

### 2 Auxiliary analogic sensor: 2 available connectors connected to the dash logger.

Auxiliary power supply		
<b>Matching connector:</b>		191 972 713
<b>Pin out</b>		Terminal
1	5v	FS 2,8 x 0,8 (*)
2	signal	FS 2,8 x 0,8 (*)
3	GND	FS 2,8 x 0,8 (*)

### Power supply cut:

There is a connector that activates the power supply to the fuse box, so in case of disconnection cuts all devices power supply.

You can unplug it in case of transport or a most safety disconnection in case of workshop big jobs.

See connector place close to the fuse box main connectors on the picture beside.

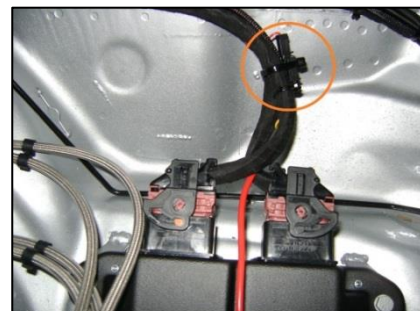

## 4 SETTING ADJUSTMENTS

### 4.1 Car delivery set-up

LEON CUP RACER		PRODUCTION SET UP		SEAT SPORT	
<b>CAR INFORMATION</b>		<b>KMS</b>	<b>TRACK INFORMATION</b>		<b>DATE</b> 20/01/2015
Chassis			Circuit		<b>FROM</b>
Engine			Lenght		<b>TO</b>
Gearbox			Driver		
<b>CAR CONFIGURATION</b>		<b>FRONT</b>	<b>REAR</b>		<b>POWER TRAIN</b>
RIDE HEIGHT		75	115		<b>ENGINE</b>
Measure point		lowes poin front subf.	lowest point rear subf.		RPM MAX 8600 Refect
<b>DAMPER SETTINGS</b>		<b>FRONT</b>	<b>REAR</b>		HP LCR 314
MAIN SPRING		160/60/110	160/60/90		<b>TRANSMISSION</b>
TENDER		60/60/2	60/60/2		Gear Ratio Vmax
ASSEMBLY LENGHT		188	206		1 13//38 0,071 55,68
BUMP STOP		25mm_D40	30mm_45		2 22//45 0,102 79,57
BUMP SPACER		<<	<<		3 28//41 0,142 111,16
BUMP		5 (5 - 10)			4 38//41 0,193 150,86
REBOUND		10 (0 - 20)	Sachs 10 (0 .20)		5 32//35 0,254 198,42
<b>ARB SETTINGS</b>		<b>FRONT</b>	<b>REAR</b>		6 38//35 0,302 235,62
TYPE		22x3	22x3		cwp 1-4 15//72
POSITION		M - M	M - M		cwp 5-6 20//72
<b>WHEELS SETTINGS</b>		<b>FRONT</b>	<b>REAR</b>		<b>DIFFERENTIAL</b>
RIM		Fond 18x10J_ET36	Fond 18x10J_ET36		VALVE 65
SPACER		0	0		
SSp delivery Tire		N2801 250/660R18 A006	N2801 250/660R18 A006		
COLD TYRE PRESSURE		2,5 bar	2,5 bar		
<b>BRAKES SETTINGS</b>		<b>FRONT</b>	<b>REAR</b>		
MASTER CYLINDER		AP 19,1	AP 22,2		
BRAKE PADS		PAGID	PAGID		
BRAKE DISCS		AP 362x32 (11P)	VAG 272x10		
PRESS RELATION		15/12	25 bars limit out		
AERO					
WING POSITION		0			
<b>ALIGNEMENT</b>		<b>FRONT</b>		<b>WEIGHT (KG)</b>	
		LEFT	RIGHT	DRIVER	75
CAMBER		5°	5°	FUEL	20
TOE std.Ride height		1.0 mm OUT	1.0 mm OUT	<b>FRONT</b>	
				LEFT	RIGHT
				<b>REAR</b>	
CAMBER		3,8°	3,8°	LEFT	TOTAL
TOE std.Ride height		0 mm	0 mm		1245
				REAR	
				FRONT	CROSS
				REAR	LEFT
<b>NOTES</b>					
Alignement with 75kg + 20kg of ballast.					

 Due to the production issues, small changes on this set up sheet can be possible. Seat Sport recommends doing your own check.

## Front and Rear set-up ride height measurement points:

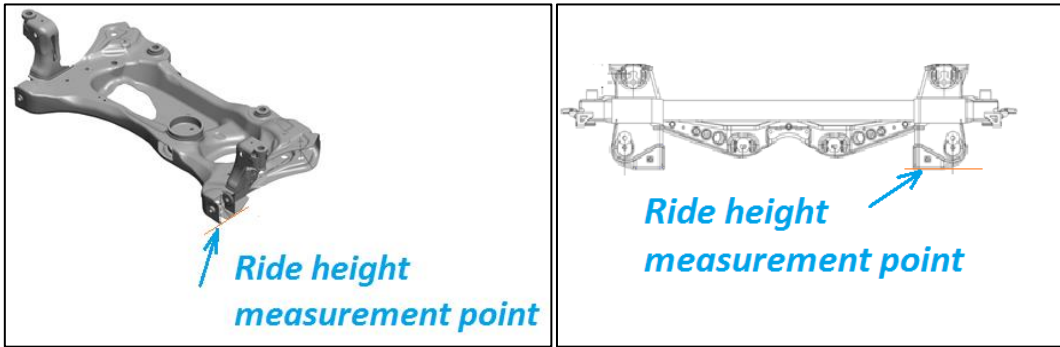

## 4.2 Steering rack centring

As the steering rack is electric, the steering angle sensor has to be electronically aligned with the wheels at the aligning time.

### How to proceed to align the steering angle sensor

It is necessary **fix the steering wheel**. To do it, you can use straps fixed between the roll cage and the steering wheel or other kind of standard tools.

The use of a rack centring stopper tool is not recommended because it is difficult to get the steering angle sensor at 0 deg. The most important is to obtain the toe alignment with the sensor at 0 deg.

Proceed as following:

- Switch on main and ignition switches.
- Turn left and right to get the steer angle signal.
- Fix the steering wheel when the steer angle is 0 deg.
- Switch off the ignition and main.
- You can now proceed to the alignment jobs.

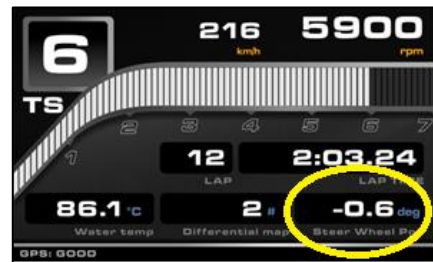

 With this process the steering angle signal will be 0 deg, with the wheels aligned. This is very important for the steering assistance and for the electronic slip differential behaviour.

## 4.3 Suspension adjustments

	Front	Rear
Wheel ratio	1 mm wheel / 0,9 mm damper	1:1
Damper travel	115 mm	118 mm

## 4.4 Front Camber and Toe adjustment

The front suspension is very special on this car due its kinematic characteristics. To reach the front suspension set up value is recommended to proceed as following:



1. **Car ride height.** Put the ride height at your choice trough damper/spring adjustments.
2. **Camber.** To change the camber is recommended to move the steering rack arm first. The camber will change quickly.
3. **Toe.** To change the toe enlarge or reduce the wishbone adjustment.
4. Check and adjust a second time if necessary.

 Although this process information seems strange, is the best and faster way to obtain the camber and toe adjustment.

### Front wishbone adjustment

Underneath the front wishbone there is a bolt to control the adjustment movement. Unblock the four screws that are fixing the camber regulator plate and proceed to the adjustment.



-  After any intervention, fix the wishbone regulator plate bolts in the right tighten.
-  Maintain the wishbone regulation plate clean and little oiled between plates.

Front regulation table (rough values).



Camber	Toe regulation	Wishbone regulation 1,5 turns = 10° camber
-6	10,5 Turns	13 Turns
-5,5	7 Turns	8,3 Turns
-5	3,5 Turns	4,5 Turns
-4,5	0	0
-4	-3,5 Turns	-4 Turns
-3,5	-6,5 Turns	-8 Turns
3	-10 Turns	-12,5 Turns

#### 4.5 Rear Camber and Toe adjustment

##### How to proceed to adjust camber and toe

1. **Car ride height.** Put the ride height at your choice through damper/spring adjustments.
2. **Camber.** To change the camber is recommended to move the “boomerang” arm.
3. **Toe.** To change the toe enlarge or reduce the rear arm.
4. Check and adjust a second time if necessary.



-  The rear Camber regulation does not have relation with the toe movement, so you can change rear camber without any toe movement.
-  After the camber adjustment job, check that the ball-joint is placed in the middle of its housing.

Rear Camber value vs rear camber regulation screw turn.

Camber	Camber arm regulation
-2	1,5 Turns
-2,5	1 Turns
-3	0,5 Turns
-3,5	0
-4	-0,5 Turns
-4,5	-1 Turns
-5	-1,5 Turns

## 4.6 Dampers

<b>Front Damper</b>
STTV technology (Single Tube Twin Valve)
2 way adjustable in bump and rebound
Aluminium outer housing
Upside down cartridge

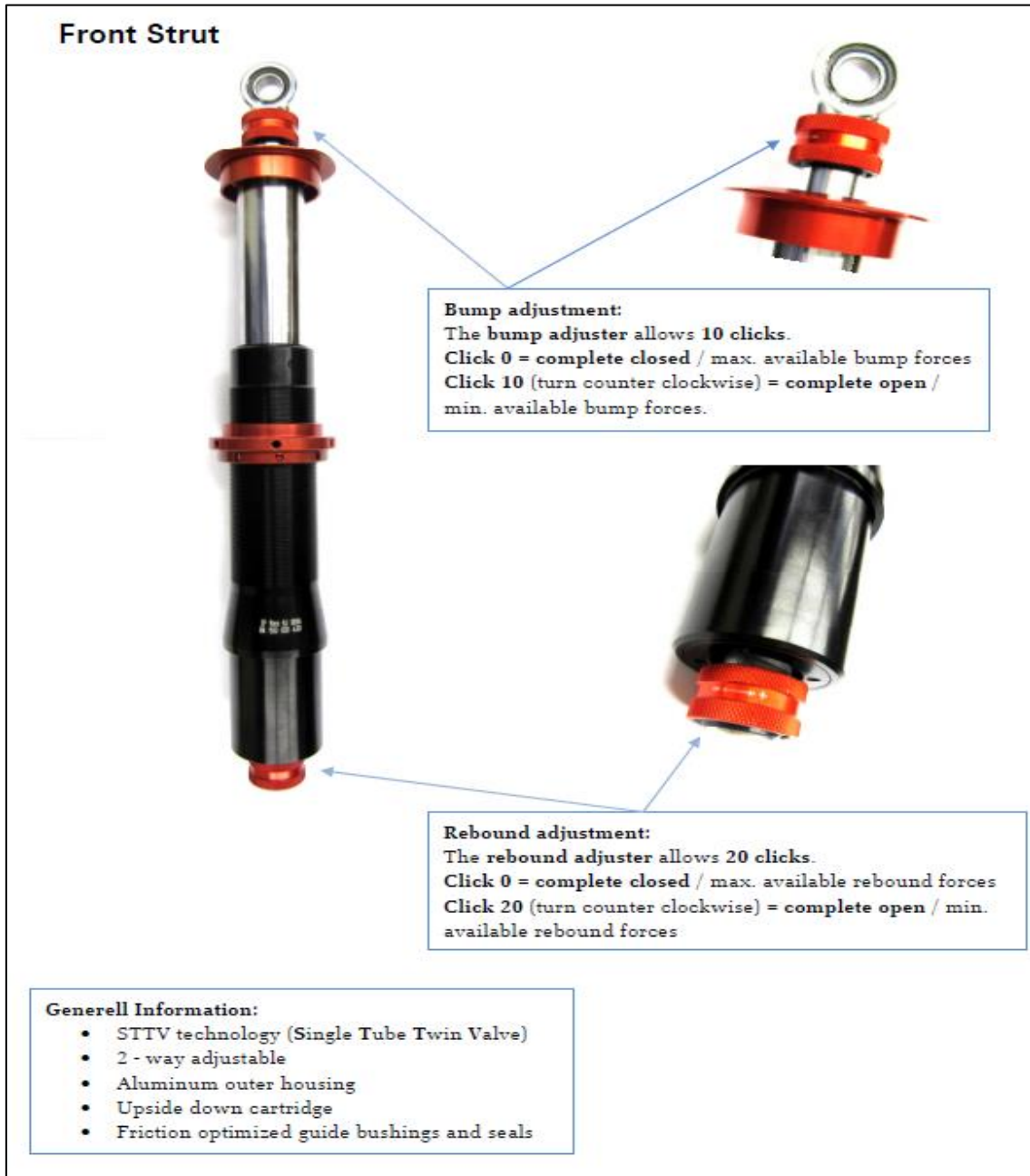

**Notes:**

- Start counting clicks from close (+) to open.
- Be careful, do not tight too hard the last closing click.

<b>Rear Damper</b>
1 way parallel adjuster
Each click adjusts the bump and rebound characteristics at the same time

## Rear Damper



**Adjustment:**  
 The rear damper is equipped with a 1-Way parallel adjuster.  
 Each click adjusts the bump and rebound characteristics parallel.  
**Click 0 = complete closed / max. available damping forces.**  
**Click 20 (turn counter clockwise) = complete open / min. available damping forces**

**Generell Information:**

- STTV technology (Single Tube Twin Valve)
- 1 - way parallel adjustable
- Aluminum body
- Friction optimized guide bushing and seals

**Notes:**

- Start counting clicks from close (+) to open.
- Be careful, do not tight too hard the last closing click.

Characteristics and adjustment range of the front and rear dampers:

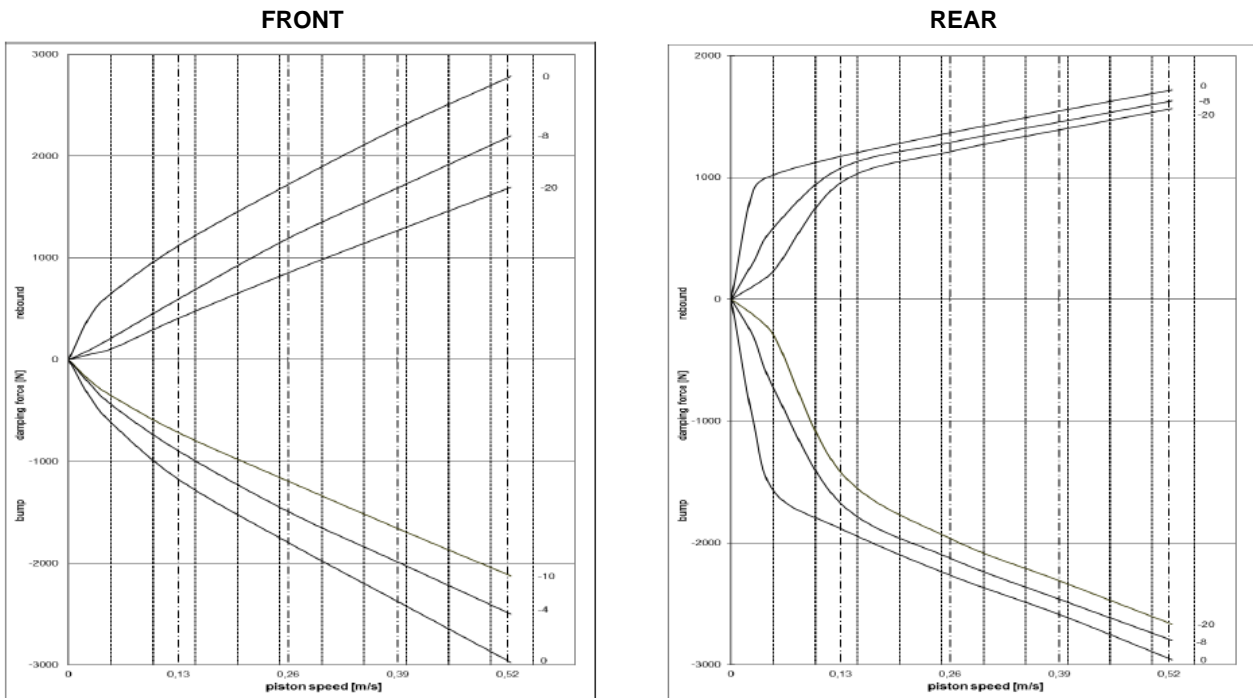

The available springs for front and rear dampers are the following:

Measures	Nm	Remark
160-60-120	120	Front use recommended
160-60-110 (car delivery - front)	110	Front use recommended
160-60-100	100	Front use recommended
160-60-90 (car delivery - rear)	90	Rear use recommended
160-60-80	80	Rear use recommended
160-60-70	70	Rear use recommended

#### 4.7 Antiroll bars

Two front antiroll bars available: 22x2 and 22x3. **Car delivery: 22x3.**

FRONT ARB		
OD (mm)	22	22
Thickness (mm)	2,0	3,0
Chassis Roll Stiffness from ARB		
Hard (Nm/°Chassis)	1548	2021
Mid (Nm/°Chassis)	991	1293
Soft (Nm/°Chassis)	688	898

Two rear anti roll bar available: 22x3 and 22x4. **Car delivery: 22x3.**

REAR ARB		
OD (mm)	22	22
Thickness (mm)	3,0	4,0
Chassis Roll Stiffness from ARB		
Hard (Nm/°Chassis)	1252	1454
Mid (Nm/°Chassis)	1061	1232
Soft (Nm/°Chassis)	898	1043



## 4.8 Kinematics

### FRONT

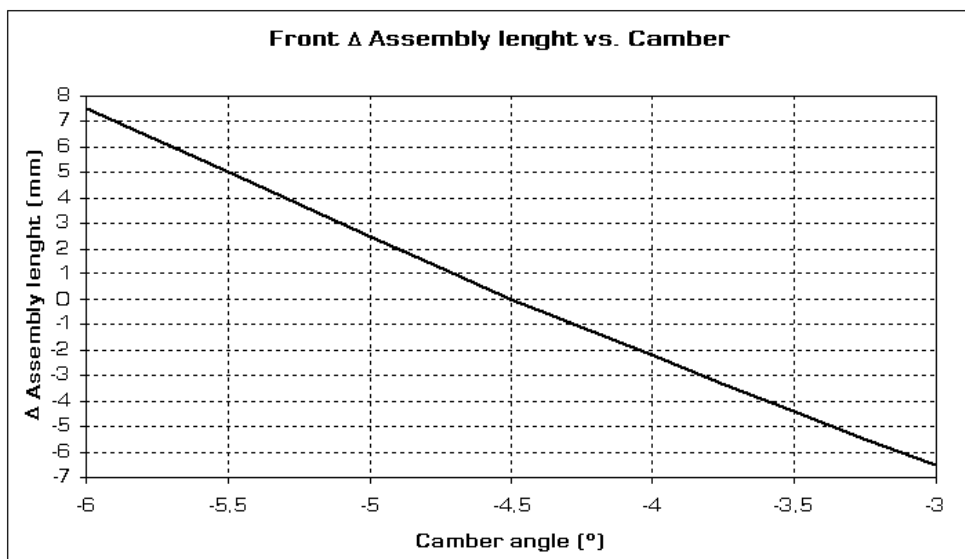
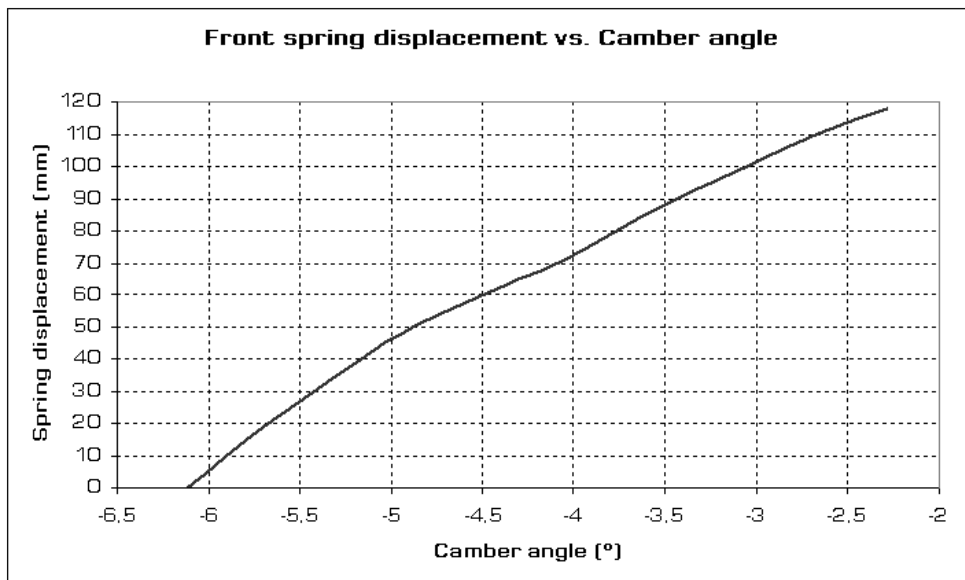
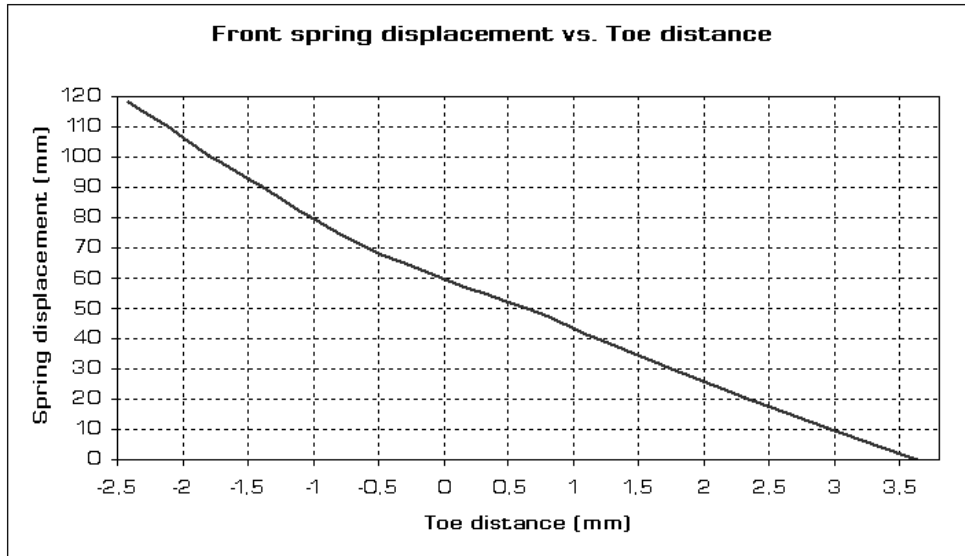

## REAR

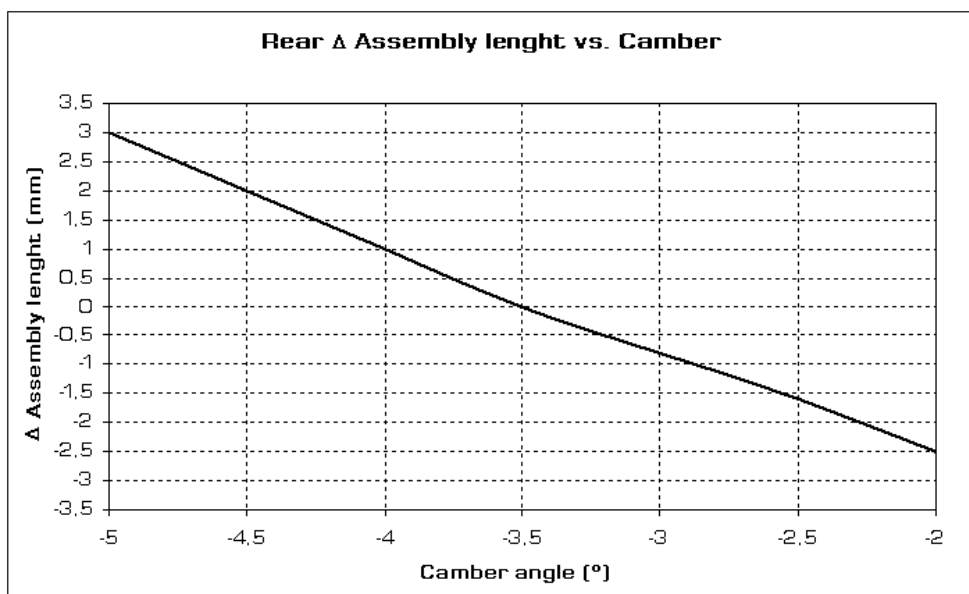
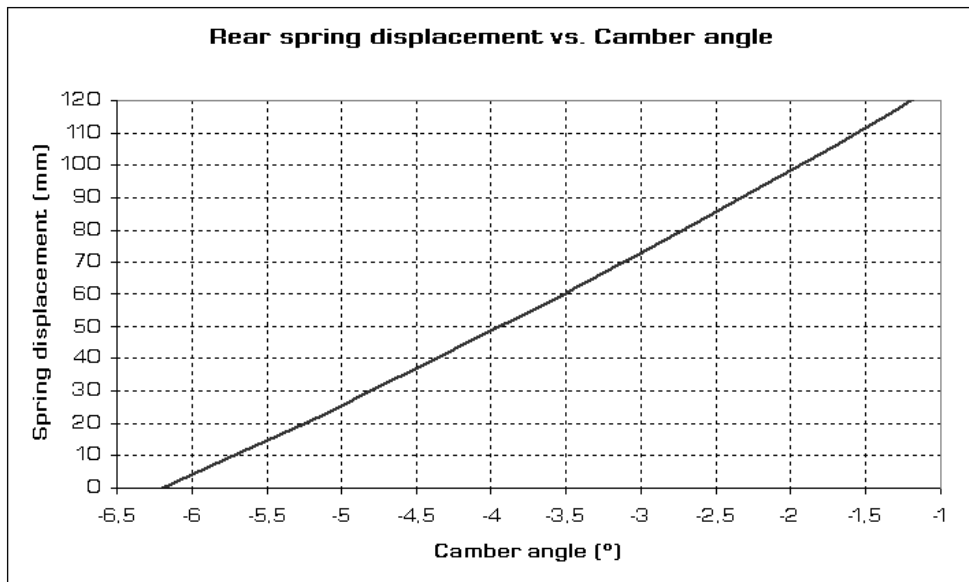
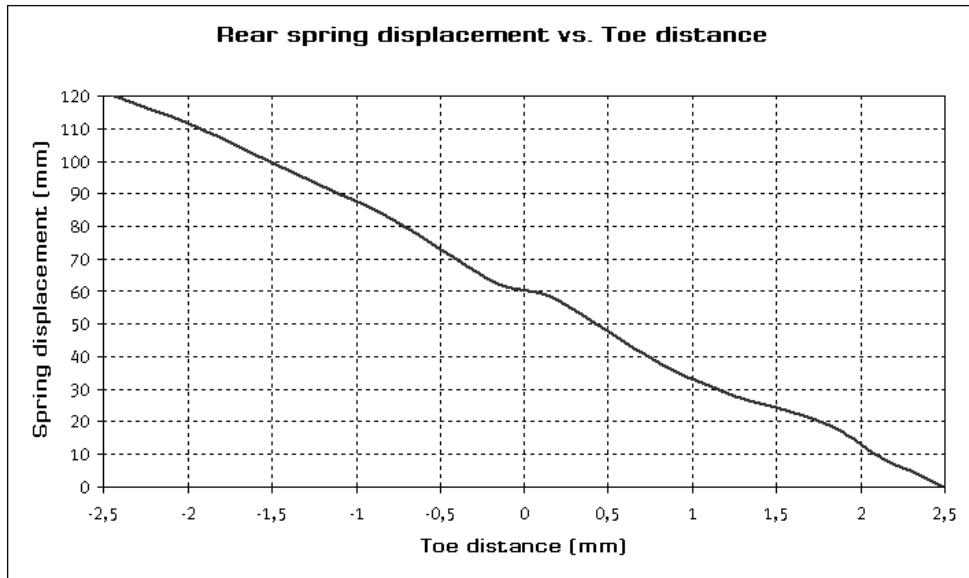

## 4.9 Brakes

Available brake pumps:

Master cylinder	Push Rod	Remarks
AP 15 MM	PRT 110	
AP 15.9 MM	PRT 110	
AP 16.8 MM	PRT 110	
AP 17.8 MM	PRT 110	
AP 19,1 MM	PRT 110	SEAT Sport car delivery
AP 20,6 MM	PRT 110	
AP 22,2 MM	PRT 110	SEAT Sport car delivery
AP 23,8 MM	PRT 110	

- It's not advisable to use more than two pump diameters difference between front and rear.
- On the dashboard screen it is shown the front and rear pressure and the balance percentage. The recommended percentage is 60% front (car delivery).
- Brake balance channel:  $\frac{P\_BRK\_FRONT}{P\_BRK\_FRONT + P\_BRK\_REAR} \times 100$

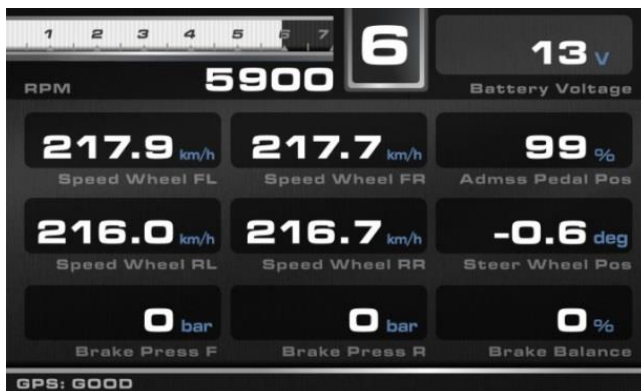

## 4.10 Aero

All aerodynamic parts have to be in good conditions. Check periodically the fixations.

Rear wing:

- The rear wing has extensive regulation. Zero is a standard setting for the car.
- Wing angle  $-5^\circ$  has considerable influence on the rear down force.
- Wing angle  $-10^\circ$  has big influence on the rear down force as well as speed.
- Lateral plates are individually adjustable when using 2015 lateral plates (see picture below).

Front splitter:

- Check periodically the fixations. It has to be in good conditions.
- Check the front splitter angle that has to be at  $0^\circ$  when pitch is  $0^\circ$ .

Pitch:

- Measure the pitch the door sill.

angle on the body shell over

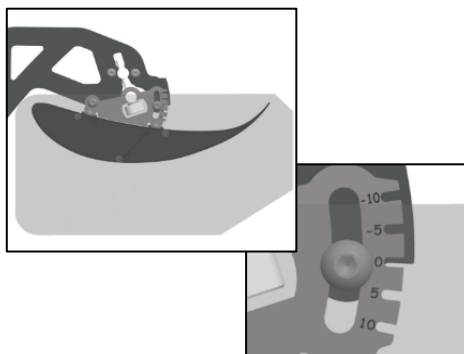

## 5 WORKSHOP MAINTENANCE

### 5.1 First rollout

SEAT Sport checks all the cars in a rollout before customer delivery. This rollout consists in:

- 5 circuit laps.
- High speed in a long straight.
- Launch control checking simulating a standing grid.
- Pit limiter checking.
- After the rollout, SEAT Sport engineers check the data acquisition and all car functions.

#### Note:

- Although SEAT Sport does a rollout, it is strongly recommended to carry out a suspension check before first customer rollout and after the first practice. Pay special attention to sub-frame, power train, engine brackets, fixations, etc.

### 5.2 Check list

After any rebuild or main job is recommend to carry out a check list. It's possible do it with a Live Measures view in RaceStudio3 with a lap top or directly using car's display.

		CHECK LIST with ENGINE STOPPED	OK
<b>ENGINE</b>	Oil level	On the dipstick mark / T_oil > 70°C	
	Water	On the bottle mark	
<b>BRAKES</b>	Brake fluid	On the bottle mark	
		CHECK STEERING WHEEL FUNTIONS	OK
<b>S. WHEEL</b>	Rain Lights		
	Driver Fan		
	Page Change		
	Safety Brake Signal		
	Diff Map Change		
	Windscreen Water		
	Wiper		
	High Beam		
<b>AIM on-line</b>		CHECK LIST with ENGINE IN IDLE SPEED	Value/OK
<b>ENGINE</b>	Water Temp	87°C / 92°C (thermostat cycle)	
	Fan	Active at 92°C	
	P_oil (WT<25°C)	4 bar	
	P_oil (WT>25°C)	2,5 bar	
	P_fuel_low	> 4,1 bar	
	Alternator	> 13,5 volts	
	Boost Press	0,3 bar @ 2500rpm	
	Speed limiter	Gear 4 @ 60km/h	
<b>GEARBOX</b>	Tipp TS	Changing gears / check SWM signal - / +	
	N gear display		
<b>DIFF</b>	Activate pump		
<b>FUSEBOX</b>	FLAG_FBX_1	0	
	FLAG_FBX_2	0	
	FLAG_FBX_3	0	
	FLAG_FBX_4	0	
	FLAG_FBX_5	0	

## 5.3 Vehicle & parts identification

V.I.N. (Vehicle Identification Number) is welded on the roll cage. N°: **VSSMK35F4ESSPXXXX**  
 (XXXX=serial number).



### Engine identifications

N°: **CJX-XXXXXX**

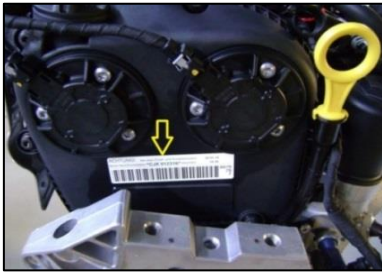

### Distribution seal detail



### Turbo seal detail

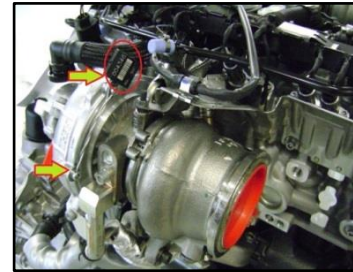

### Gear box identification

N°: **C0XX**



### Slip differential identification

N°: **D0XX**

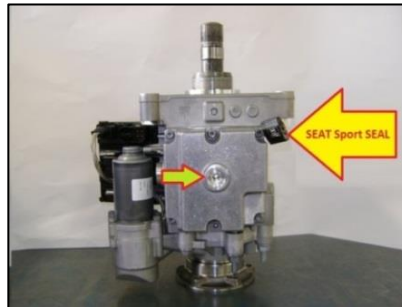

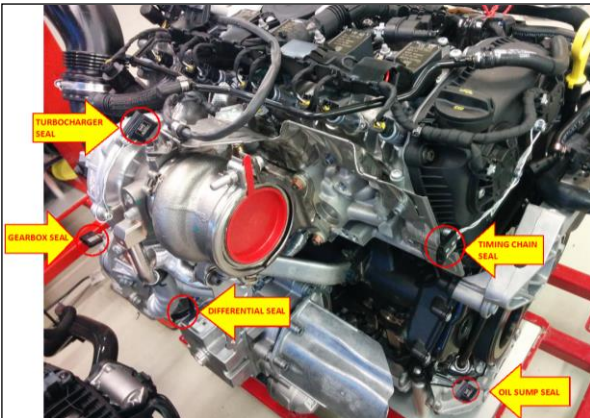

### General ENGINE seals view

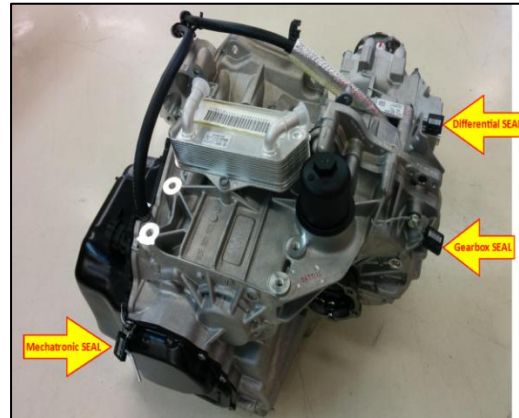

### General GEARBOX – DIFF seals view



## 5.4 Fluids information

Fluids	From	References	Quantity
Engine		CASTROL EDGE 5W-30 VN0000053000	Substitution with filter change 5,7 l
Gear box	VW-Audi	_G052182A2	Substitution 5,2 l Mechatronic 3 – 4 l
Electronic Slip Differential	VW	_G060175A2	Unit 0,7 l Substitution 0,5 l
Drive shaft	VW-Audi	VN0000040401	100 gr
Coolant		VN0000060400	5 l
	VW	_G013A8JM1	
Brake fluid		CASTROL SRF VN0000062400	
Fuel	PANTA (Eurocup SEAT)	NS 102 Ron	
Windscreen cleaner	Free		

### Notes:

- SEAT Leon Cup Racer: Use only the fuel distributed on the race track.
- It is forbidden any product addition on the fuel.
- Fuel: standard fuel 98 Ron from petrol stations to 102 Ron.
- Is recommended not to mixt fuels, could contaminate one from the other.
- Gearbox and Slip differential are supplied with the right level. It is not necessary any level control if there are not leakages.

## 5.5 Engine service

Control routine before start to run:

- Check the oil level: With the oil temperature up to 70°C, stop the engine and wait 2 minutes, then you can check the oil dipstick. The oil level must be at the top of the marked zone on the dipstick.
- Check the water level before start.
- With the engine running, check there is not any oil, water or fuel leakage.
- Check the fan functionality. Operating range 92°C to 87°C.

Maintenance routine:

- Change the engine oil and oil filter at the indicated mileage.
- Engine spare parts must be from VW group or SEAT Sport original parts, detailed on the Leon Cup Racer parts catalogue.
- Use always fluids detailed on the Leon Cup Racer parts catalogue.
- Clean and check the air filter in each event. At the urban circuits it is recommended to clean or replace more frequently. It is also recommended to have two or three air filters and replace during the weekend. Changing it is strongly recommended in case of rain.
- Check that the alternator belt is clean and that there are not small stones inside the Poly-V.
- Clean the radiator and intercooler panel often.
- If any doubt, contact to the SEAT Sport service.
- Check the SEAT Sport seals are in good conditions.

Parts subject to frequent service:

Engine	Torque	Remarks
Oil drain plug	By hand	Change the plastic cap
Oil filter plastic cover	50 Nm	
Oil filter	<<	Moisten the "O" ring
Spark plug	2,8 Nm	Use original VW parts

For detailed parts substitution information download yourself the Workshop Manual from our web [www.seat-sport.com](http://www.seat-sport.com).

## 5.6 Air filter

Air filter	Torque	Remarks
Air filter substitution	By hand	4 small bolts over plastic. Be careful.
Air filter clean		Clean the cotton air filter following the procedure shown below. <b>DO NOT use compressed air or high-pressure air to clean.</b> Use only recommended oil for cotton filters.

### Notes:

- The air filter type and measurements are identified on the Technical Regulations. It is not allowed any modification or change.
- The air filter clean and properly oiled is critical for the turbo charger life. **It is strongly recommended to follow the cleaning procedure as well as the timing.**
- After using in rain conditions is recommended the cleaning or replacement.

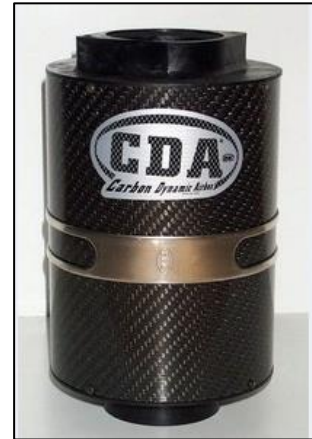

### Air filter standard cleaning procedure

- 

**1**

Remove the larger dirt by shaking or tapping your filter gently onto a clean surface. **DO NOT** use compressed air which may damage the filtering element.
- 

**2**

Distribute the BMC detergent on the filter. Allow to absorb for about 10 minutes. **DO NOT** use caustic products such as petrol or oil. **USE ONLY BMC DETERGENT.**
- 

**3**

Wash your filter in cold water. Rinse well ensuring that dirt does not enter the filter pleats. **DO NOT** use high-pressure water.
- 

**4**

Let in a accurate proper way your filter dry naturally away from heat sources on absorbent paper or on a clean cloth. **DO NOT** use a hair-dryer or compressed air.
- 

**5**

Remove the original top from the regenerating fluid bottle. Make a small hole in the spout dispenser and screw onto the bottle. For correct oiling we recommend passing the regenerating fluid twice over every pleat on both sides of the filter.
- 

**6**

The oiling procedure using the aerosol spray. Hold the spray 15 cm from the filter and spray the complete surface. Repeat the operation on both sides of the filter.
- 

**7**

Allow the oil to absorb on a level surface for around 30 minutes. Remove any excess oil on the rubber and check that the filtering element is homogeneously red (Picture 7). If not, repeat the oiling process described Previously. After oiling the filter is ready to be reinstalled.

## 5.7 Gearbox control & service

Control routine before start:

- Check that there isn't any oil leakage.
- Operating range 70°C to 135°C.
- Do not load the engine until the gear box temperature its upper to 70°C (control on the display).

Routine maintenance:

- Change the gearbox oil and filter in the indicated mileage (see mileage table).
- Oil filter, as well as the rest of the gearbox spare parts, must be from VW group or SEAT Sport original parts, detailed on the Leon Cup Racer parts catalogue.
- If there is not any oil leakage it is not necessary any level control (paragraph 6).
- Check that the SEAT Sport seals are in good conditions.

How to change the Gearbox oil:

- With the gearbox oil temperature below 50°C, the lever in position P, the vehicle on a level and the engine stopped, remove the oil drain plug and the overflow pipe located inside.
- Wait until all the oil runs out, more or less 5 litres, and screw the overflow pipe again (3Nm). Change also the gearbox oil filter.
- Fill 5,5 litres of new oil and hand-tight the oil drain plug. Seat Sport recommends using the adapter for the gearbox oil filling (VAS 6262A). If not fill it from the oil filter housing (much slower).
- Start the engine. Depress brake pedal and select each selector lever position for 3 seconds. Then go back to P. Do not switch off the engine.
- With the engine running at idle speed and the gearbox oil between 35 and 45°C, remove the oil drain plug again and let the surplus oil drain out. When it begins only to drip, install the oil drain plug with new seal (45Nm).



**Note:**

- If when doing the level after removing the oil drain plug no oil drains out: stop the engine, add 0,5 litres more and repeat the process from running the gearbox in all selector lever positions.

How to adjust the gear and selector levers:

- Unscrew the selector lever bolt (see picture).
- Put the lever in P.
- Turn the gearbox selector lever backwards.
- Screw the selector lever bolt.

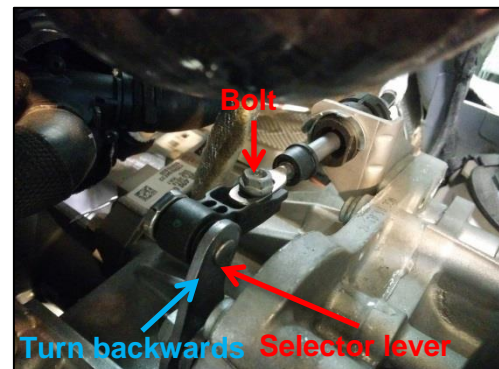

## 5.8 FDX - Slip differential control & service

Routine maintenance:

- Change the FDX oil in the indicated mileage (see mileage table). Use only the recommended oil.
- If there is not any oil leakage it is not necessary any level control.
- Send to SEAT Sport for revision when recommended service mileage is reached.

Slip differential	Torque	Remarks
FDX oil level check cap	15 Nm	Change every time



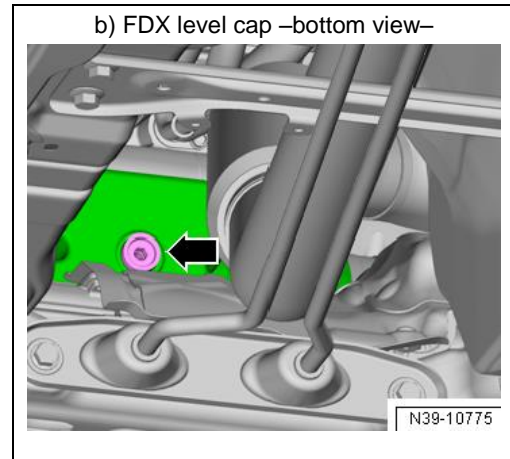
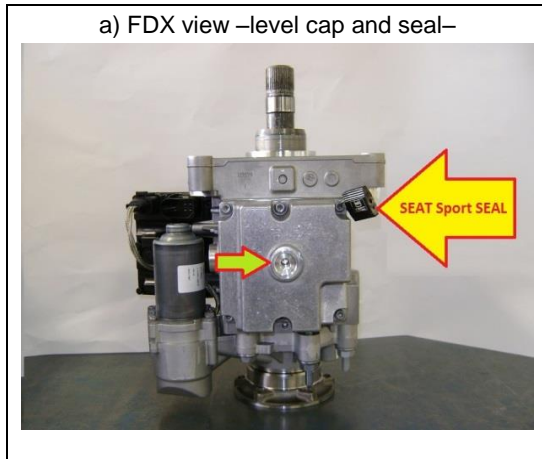

### How to change the FDX oil:

To replace the oil is recommended to disassemble the unit from the car. Open the cap bellow, drain it and close it again. Measure the quantity and put in the same quantity. If you are doing it mounted on the car, take care, 100 ml will not be possible to add from the cap (shown in the picture b) above). The last 100 ml have to be added through the venting pipe on top.

### **Note:**

- In case of disassembling the unit from the car, the unit must be positioned in vertical position, as it is shown in the picture a), to avoid any oil leakage.

For detailed parts substitution information download yourself the Workshop Manual from our web [www.seat-sport.com](http://www.seat-sport.com).

## 5.9 Fuel

The fuel tank is coming from series, using the standard flow fuel pump and adding a second flow pump on the other side.

Standard Fuel tank features	Description
Fuel tank type	Standard fuel tank from Quattro version
Capacity	55 l standard tank / *60 l additional fuel tank in option (coming from LR version). See below.
Minimum fuel level before engine fault	> 8 l (in long corners with high lateral forces)

Additional fuel tank features	FT3 FIA Homologated
	60 l additional fuel tank // possible to reduce the capacity by adding balls.
	This additional fuel tank does not have fuel pump. It supplies the main tank by gravity.

### **Notes:**

- The Quattro version fuel tank allows the use of a straight exhaust system, decreasing the fuel temperature due to the exhaust irradiation. Check periodically that all tank protections are in good conditions.
- After a crash or out of track driving check the inner flow fuel pumps fixations.

### Fuel tank drain:

- The hydraulic: There is a FIA fast fuel coupling placed on the engine bay. The contra connector is available on the parts catalogue.
- The electric: The car wiring loom is ready to connect an external interface wiring in order to activate the main fuel pump directly.

How to proceed:

- For the fuel tank pump activation it is necessary to connect the Seat Sport tool between the fuel pump wiring connector, placed on the right rear door and beside the auxiliary power supply. Unplug car's connector and plug the Seat Sport tool connector.
- Connect the front hydraulic pipe to FIA fast coupling.
- Connect now the tool to the main supply auxiliary connector and push the switch.

For safety, it is strongly recommended to carry out the process with the main switch off.

Seat Sport draining tool

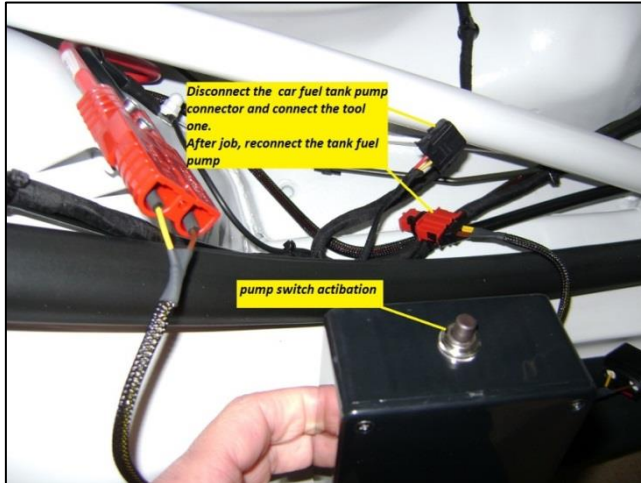

Fast fuel coupling (FIA homologated)

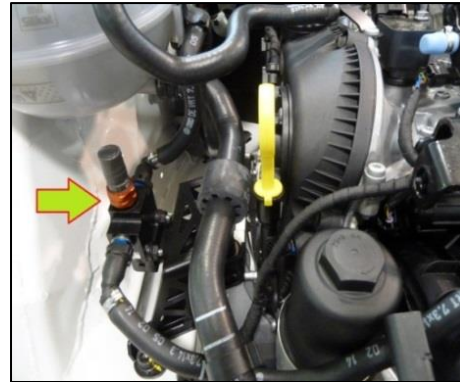

## Notes:

- **IMPORTANT:** Take care not to damage the fuel pump during the drain process. Do not maintain the pump activated without fuel. Stop the drain when air bubbles appear.
- **IMPORTANT:** The drain tool connects directly to the battery. **DO NOT ACTIVATE THE TOOL SWITCH WITH THE CAR MAIN SWITCH ON.**
- On the Leon Cup Racer parts catalogue it is available the extraction kit.
- To carry out this procedure, it is also possible to connect the extraction tool to an auxiliary help battery.
- The Leon Cup Racer body shell is ready to add an additional fuel tank. This tank would be connected in line with the first one and supplies the fuel to it.

## 5.10 Electronic modules

The car has installed the following modules:

Electronic modules	Remarks	Place
Engine ECU	Continental /Symos 18.1	Engine bay
Gearbox mechatronic	VW	Inside gear box
Electronic slip differential	BorgWarner	FDX (external)
Low fuel pump control	PWM control module	Fuel tank (external)
Electronic steering rack	VW	Front subframe
ESP unit	Continental (not hydraulic connexion for cup cars)	Cockpit
Gateway	VW	Cockpit
Black box	Audi	Cockpit
MXG display / logger	AIM	Cockpit
Fuse box	SEAT Sport	Cockpit
Steering wheel module	SEAT Sport	Cockpit
Transponder		Engine bay

## 5.11 Airjack

The SEAT Leon Cup Racer car is using the Krontec quick lift Airjack System. For more information visit the following webpage: [http://www.krontec.de/katalog\\_e/start.htm](http://www.krontec.de/katalog_e/start.htm)

Air lance:

**LL-03 easy push**



**LL-16**



Part No.	Beschreibung Description	Gewicht Weight [g]	Gewinde Thread	Betriebsdruck Operating Pressure [bar]	Größe Size L / Ø
<b>KRONTEC Lufilanzenystem bis 40 bar / KRONTEC Air lance system up to 40 bar</b>					
LL-03	Luf lance/Air lance „easy push“		M16 x 1,5 fem'	0 – 40	230 / 37 mm
LL-16	Anschlussventil/connection valve	60	06D	0 – 40	86 / – mm

## 6 PARTS MILEAGE

ENGINE	Inspection	Service / km	Change	Remark
Engine		8.000	12.000	Serviced by SEAT Sport
Spark plug			2.000	Use original parts only
Engine oil			1.000	Use recommended oil only
Oil filter			1.000	Use original parts only
Cotton air filter	Once x event	Once x event	season	2 units rolling change adv.
Poly-V belt	Once x event		2.000	

TRANSMISSION	Inspection	Service / km	Change	Remark
Gearbox		8.000	12.000	Serviced by SEAT Sport
Oil gearbox			5.000	Use original parts only
Gearbox oil filter			5.000	
FDX (slip differential)		8.000	12.000	Serviced by SEAT Sport
FDX pump			4.000	Replace at this mileage
Oil FDX			5.000	Use recommended oil only
Drive shaft	Once x event	5.000	10.000	

FRONT AXLE	Inspection	Service / km	Change	Remark
Front dampers		5.000 / 1 year	8000	Seat Sport service
Ball joints	Once x event		5.000	Always check tolerance
Steering rod inner joint	Once x event		5.000	Always check tolerance
Steering rack			15.000	
Steering handle	Once x event		4.000	Replace at this mileage
Wheel hub	Once x event		10.000	Change when noise
Front discs	Once x event		1.500	Change when cracks
Disc bells			5.000	
Brake balance bar	Once x event	4.000		

REAR AXLE	inspection	Service / km	Change	Remark
Rear dampers		5.000 / 1 year	8.000	Seat Sport service
Ball joints	Once x event		5.000	Always check tolerance
Wheel hub	Once x event		10.000	Change when noise
Rear discs (solid)			1.500	
Wheel nuts			3.000	

SECURITY PARTS	Service / km	Change	Remark
Extinguisher	5 years		Service in SSp or OMP
Bucket		5 years	
Safety belts		5 years	

7 SAFETY

SAFETY	Remarks	Images
<p><b>AIRJACK</b></p>	<p>3 airjacks on the car. Max pressure 30 bar.</p> <p>Safety Props: For any job under the car <b>use ALWAYS</b> airjack safety props (x3).</p>	
<p><b>EXTINGUISHER</b></p>	<p>Material: Aluminium. Weight: 6.2 kg. Activation: Electric. Use: Cockpit and engine bay.</p> <p>Check the inner press bottle. Have to be in the green area. Fire extinguisher system: Check always that the 9V inner battery is in good conditions. Do not forget to put the toggle in "on" when car is running.</p>	
<p><b>BACKET</b></p>	<p>FIA Homologated 8855 – 1999 Gel coated fiberglass shell W side fixing points HANS Compatible</p> <p>Check the homologation label "expiry date" period. Check <b>ALWAYS</b> the fixations. Change if big crash.</p>	
<p><b>SAFETY BELT</b></p>	<p>Check always the fixations are well fixed. Check the homologation label "expiry date" period. Check always the driver is strongly fixed.</p>	