

# Abraham and Sarah

## Obedience

### Lesson 4

#### Lesson Objectives

- The children will identify Abraham as a man who obeyed and trusted God.
- The children will list ways that they can obey God as Abraham did.
- The children will state that being obedient makes them happy.

#### Lesson Text

Genesis 12

#### Scripture Memory Verse

This is love for God: to obey his commands.

*1 John 5:3*

#### Lesson Plan

Greeting and Registration

Preclass Activity: Abraham's Map

Welcome and Singing

Centers:

Bible Story: Abraham Obeys God

Life Application: Blind Man's Trust

Craft: Obey Clock

NOTE: Be sure to allow sufficient time for a snack.



# Abraham and Sarah

### Abraham's Map

The children will become acquainted with the geography of the region where Abraham lived by making props for the Bible Story Center.

#### Materials

*For the teacher:*

- large sheet of poster board
- markers
- brown and blue crayons
- tape
- scissors

#### Preparation

1. Using Figure A as a model, draw a copy of the map onto the poster board. Draw the map to completely fill the paper. Be sure to mark all the locations as detailed in the drawing.
2. When you are finished, cut the map into puzzle pieces large enough for the children to color. The pieces should be simple shapes like squares that fit together easily.

#### Instructions

1. Give each of the children a piece of the map as they enter the class.
2. Explain that you have given them a piece of a map. Identify for them whether their puzzle pieces represent land and/or water. Have them color the water blue and the land brown.
3. Have the children write their names on their puzzle pieces.
4. At the end of the activity, you and the children can put the puzzle together. As you fit the pieces together, discuss the climate of the Middle East where Abraham lived: dry, hot, etc. Ask them if it is dry and hot where they live.
5. Tape the puzzle together and keep it to use as a prop during the Bible Story center.

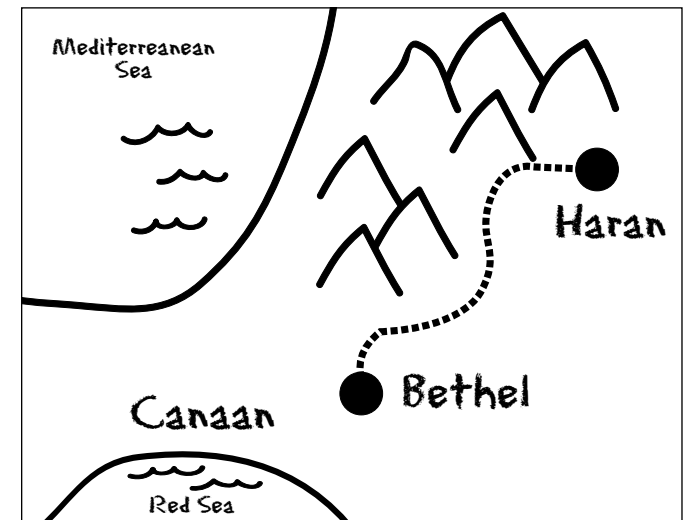

Figure A

# Abraham and Sarah

## Abraham Obeys God

The children will learn that Abraham obeyed God even when it was difficult.

### Lesson Text

Genesis 12

### Materials

*For the teacher:*

- Abraham's Map from the Preclass Activity
- 1 piece of sandpaper
- small piece of cloth to use as a tent for the figures
- a bathrobe for a costume
- markers
- scissors

*Reproducible Pages:*

- Page A, 1 copy for the teacher

### Preparation

1. Cut the sandpaper into strips and place them along Abraham's path on the map.
2. Cut out and color the figures of Abraham and Sarah from the copy of Reproducible Page A.

### Abraham's Journey

Put on the bathrobe to tell the Bible story. Place the puzzle on the floor and sit near it. Have your Bible in your lap, opened to Genesis 12:1.

*Have you ever taken a long trip with your family to a place you have never been? Were you excited? Maybe you were scared? Did you think you and your family might get lost? Maybe you were just happy knowing you were with your family and that they would take care of you no matter where you were or what might happen?*

*Today we are going to meet Abraham and Sarah. Bring out the figures and the tent. Put the figures on the map in Haran. They were very, very old. They had lived in one place for a long time. One day God said to Abraham: "Leave your country, your people and your father's household and go to the land I will show you" (Genesis 12:1). So Abraham and Sarah packed up their things, their servants and their animals, and they left. They walked for many, many miles.*

Have the figures move on the map southeast toward Canaan. *God had promised them that he had a land for them to live in so they trusted him and went where God told them to go.*

*Abraham always listened to God and always did what God told him to do. He obeyed God. What does it mean to obey? Take a few responses. That's right! It means that we do what we are told to do. Abraham obeyed God by packing all his things and going where God told him to go. It was not easy for Abraham to do this. It took much hard work to move, because they had many things to pack, and they had a long way to travel. They did not have a car or a train or a bus to travel in back then. God took care of Abraham and Sarah, though, because they trusted and were obedient to him.*

*Abraham and Sarah walked for a very long time and were very happy knowing that God was with them. God promised to take care of them, and he kept that promise. What does it mean to keep a promise? Take a few responses from the children. Yes, keeping a promise is when someone does what he says he is going to do.*

*Move the figures southwest on the map toward Bethel. Finally, they came to another new place. That place was called Bethel.*

*Abraham and Sarah learned to listen to God and to obey him. God always loved and took care of them and their family. Abraham and Sarah obeyed God, and God always kept his promises to them.*

### Conclusion

Ask the following questions for discussion and review.

- *Who was Abraham's wife?* (Sarah)
- *When we learned about them, were they young?* (no)
- *Who can show us on the map where Abraham lived when God called him or asked him to move?* Have the child place the Abraham figure on Haran. *That place was called Haran.*
- *Who can show us where God led Abraham and Sarah?* Have the child place the Abraham and Sarah figures on Canaan. *That place was called Canaan.*
- *Did God keep his promise to Abraham and Sarah?* (yes)
- *Did they trust God?* (yes)
- *How do you think God felt about them when they obeyed?* (happy)
- *Do you think Abraham was happy when he obeyed?* (yes)
- *How can we be like Abraham and listen to God?* (obey our parents and teachers)

# Abraham and Sarah

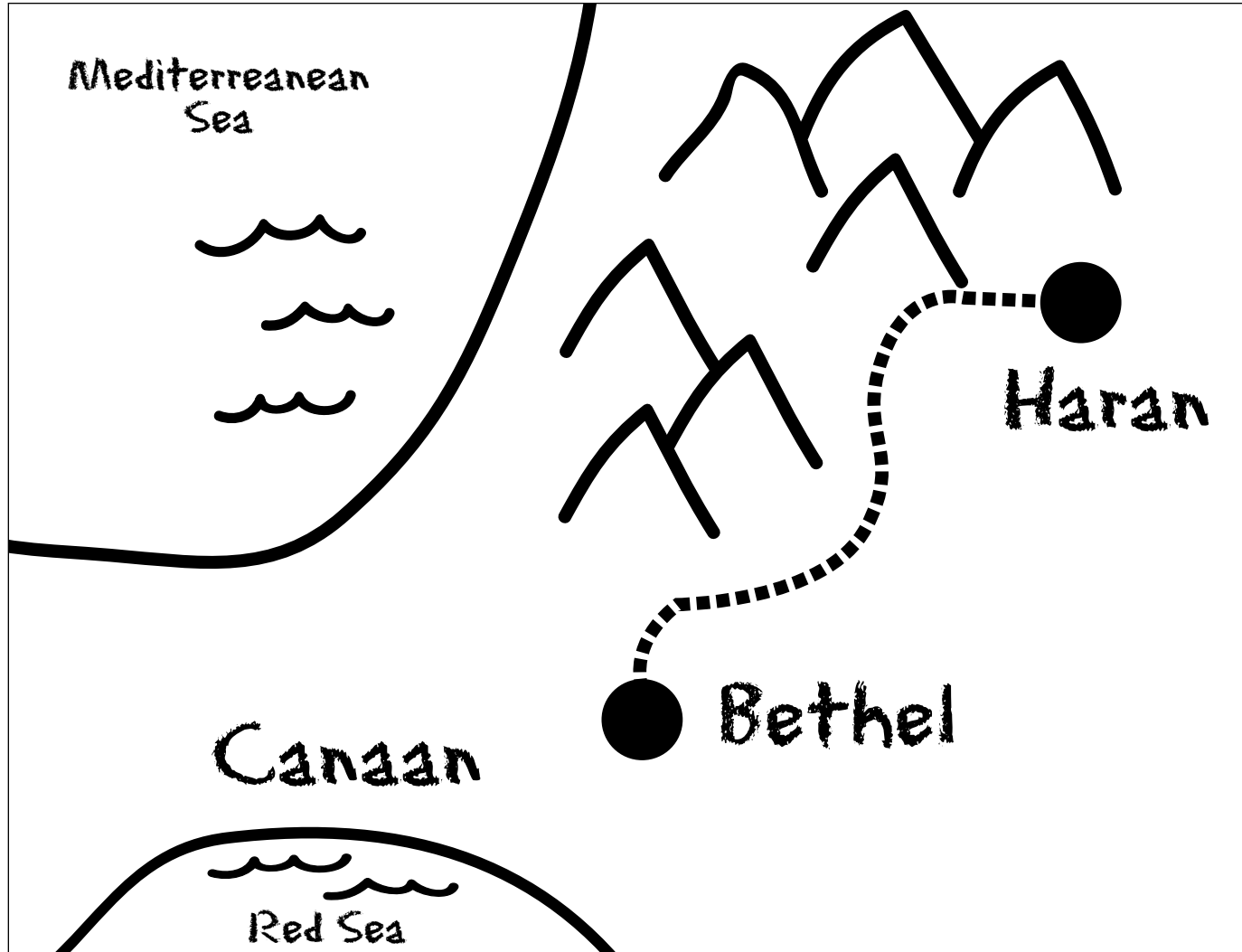

# Abraham and Sarah

### Blind Man's Trust

The children will learn the concepts of trust and obedience by being blindfolded and led by a teacher.

#### Scripture Memory Verse

This is love for God: to obey his commands.

1 John 5:3

#### Materials

For the teacher:

- a scarf or piece of cloth for the blindfold

#### Preparation

If possible, the teacher should practice this activity with a child.

#### Instructions

1. Blindfold the first child and direct him by taking his hand and giving him instructions such as: *Move two steps forward, then turn toward my voice and go four steps*, etc. Many children will not know "right" from "left" so be sure to lead them by the hand.
2. Give each child a turn being blindfolded and guided.
3. Have the children talk about how they felt while they were blindfolded. Ask them the following questions:
  - *Did you know where you were going?*
  - *Was it easy for you to obey?*
  - *How did you feel about not knowing where you were going?* (express that this was probably how Abraham felt)

#### Scripture Memory Activity

To use time effectively, have each child recite the memory scripture before taking a turn being blindfolded.

#### Conclusion

Ask the following questions for discussion and review.

- *Who in the Bible did not obey God when God told him to do something?* (Adam)
- Review how Adam and Eve listened to the serpent and did not trust and obey God. *Did Adam and Eve listen to God or to Satan?* (Satan)
- *Why did Adam and Eve disobey God?* (They did what they wanted to do even though God said not to do it.)
- *Abraham was different, though. How was Abraham not like Adam and Eve?* (He listened to God, and he obeyed even though he did not understand where he was going.)
- *What are some ways that you can be like Abraham at home?* Have the children describe ways that they can obey when they're told the first time, such as going to bed, cleaning their rooms, coming to dinner, etc.
- *How do you feel when you obey?* (happy)

*Sometimes it is hard to obey because we don't understand what someone is asking us to do or we just don't want to listen to them. But God says that if we obey it makes us happy. Our friends need to know that being obedient will make them happy. Who do you know that needs to hear that obedience will make them happy? Let's ask God to help us to be obedient. Choose a child to pray.*

#### Teacher Tips

You may not have enough time to ask all the questions. Be sure to give each child a turn to be blindfolded and then ask the first four questions. Go on to the rest of the questions only if time permits.



# Abraham and Sarah

Life

A  
P  
P  
L  
I  
C  
A  
T  
I  
O  
N

This Is Love for God:  
to Obey His  
Commmands.

1 John 5:3



# Abraham and Sarah

## Obey Clock

The children will understand, through the concept of time, how Abraham responded to God's commands.

### Materials

*For each child:*

- 1 white paper plate, 6"
- brass fastener
- stickers for decoration
- markers, crayons or colored pencils
- tape
- glue stick

*For the teacher:*

- ruler
- pencil
- poster board
- scissors
- hole punch

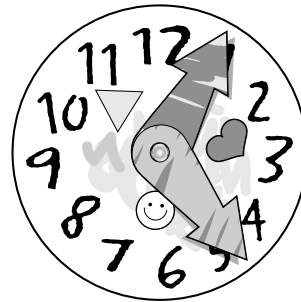

### Preparation

1. Make a clock face for each child as follows:
  - A. Using the ruler, mark a thin line from the top to the bottom of each paper plate. Trace a second line, from left to right across each plate. See Figure A.
  - B. Punch a small hole in the center of each plate where the lines meet by using a pencil.
2. Make the clock hands for each child:
  - A. On a piece of poster board, draw two clock hands, one longer than the other.
  - B. Draw an arrowhead on one end of each hand. Cut out the hands. See Figure B.
  - C. Punch a small hole in the flat end of each clock hand.
3. Make a finished model as follows:
  - A. Write the numbers around the plate to make a clock face, as shown in Figure C.
  - B. Attach the two clock hands to the face with the brass fastener.
4. Keep your model for Unit 2 Lesson 7.

### Instructions

1. Show the children the model clock and explain time as follows:
  - A. Ask them to name times of the day that they obey. For example, ask them when they go to bed, clean-up, get dressed, etc.
  - B. Moving the clock hands, show the different times on the clock. This will help the children to learn how to tell time.
  - C. Discuss how Abraham did not wait to obey God. He did what God wanted him to do at the time God asked him to do it. He did not do it later; he obeyed God the first time. The clock will remind them of the times they need to be obedient.
2. Give the children the hole-punched plate, markers, clock hands, stickers, and glue.
3. Instruct them to write the numbers on the face of the clock, using your model as a guide. Be sure the model is where everyone can see it well. Help the children as needed. See Teacher Tips for further tips on helping children with writing numbers.
4. Have the children decorate the clock faces with the stickers and markers. Use this opportunity to continue discussing the idea of timely obedience.
5. Carefully place the brass fastener through the hole in the clock hands and then through the plate hole. Open the brass fastener wings and press them flat. Tape the wings to the plate, as shown in Figure D.

### Teacher Tips

- Some five year olds will need help writing numbers. Most four year olds will not be able to write the numbers at all. Let them know it's fine to need help. Help them if they ask you, but let them be creative. It's fine if they color and do not put numbers on the clock.

# Abraham and Sarah

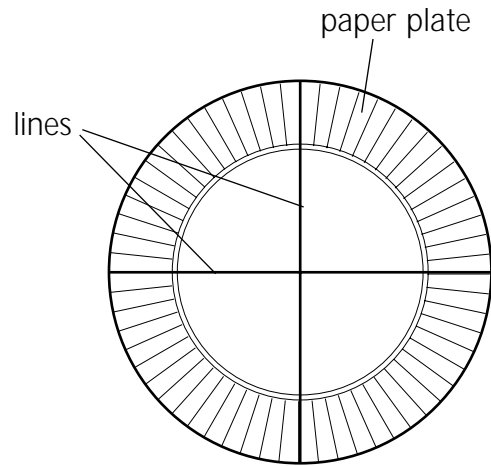

Figure A

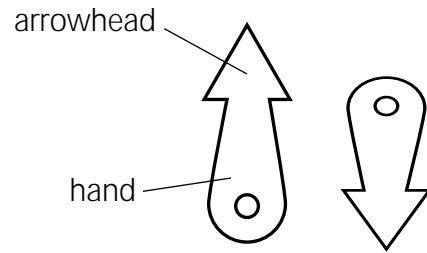

Figure B

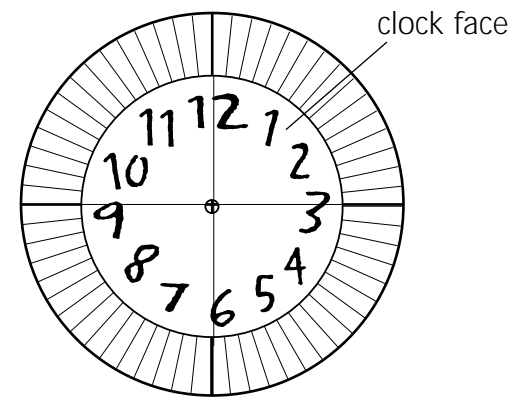

Figure C

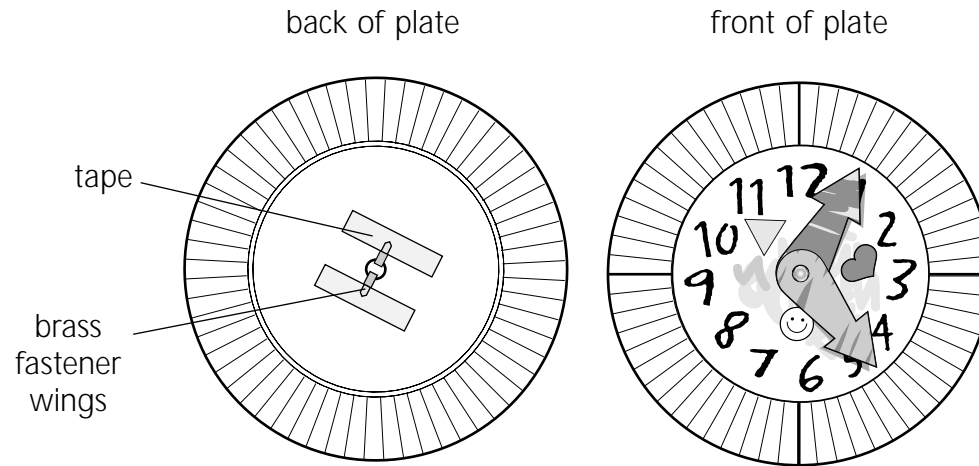

Figure D





Pre class



# Abraham and Sarah

## Obedience

Lesson 4

### Lesson Objectives

- The children will identify Abraham as a man who obeyed and trusted God.
- The children will list ways that they can obey God as Abraham did.
- The children will state that being obedient makes them happy.

### Lesson Text

Genesis 12

### Scripture Memory Verse

This is love for God: to obey his commands.  
1 John 5:3

### Doorknob Hanger

The children will create doorknob hangers that will illustrate ways in which they can obey.

#### Materials

*For each child:*

- marker
- glue
- crayons
- string, 10" long

*For the teacher:*

- 1 piece of construction paper for every four children
- 1 piece white paper, 8½" x 11" for every five children
- poster board
- hole punch
- scissors

### Lesson Plan

Greeting and Registration

Preclass Activity: Doorknob Hanger

Welcome and Singing

Centers:

Game: Follow Abraham

Craft: Bible Walkman

Life Application: Blind Man's Trust

NOTE: Be sure to allow sufficient time for a snack.

### Preparation

1. Cut the poster board into a 7" x 4" rectangle for each child and punch a hole near the top of each piece.
2. Cut each piece of colored construction paper into four pieces of equal size.
3. Cut each piece of white paper into five pieces of equal size.
4. Near the tops of each paper, write one of the following obedience directives: "share," "help," "read my bible," or "pray."

### Instructions

1. Distribute the obedience directives, one for each child.
2. Ask the children to draw pictures on their papers illustrating the correlating act of obedience. For example, say: *Your paper says "Help." Can you draw a picture of you helping someone?*

3. Have the children glue their papers onto pieces of colored construction paper.
4. Have the children glue the construction paper onto the poster board.
5. Tie a string through the hole in the top of each piece of poster board.
6. When the children finish their crafts, write on the top of each door hanger: "Today, I'll obey!"

### Teacher Tips

As the children make their crafts, discuss different acts of obedience and how it makes God happy when they obey.



## Follow Abraham

The children will learn obedience through following instructions.

### Materials

For each child:

- robe or sheet for a tunic
- scarf, or small hand towel with scarf, for a headpiece



### Preparation

Collect the materials for each child as well as yourself.

### Instructions

1. Explain to the children that they will be playing a game called "Follow Abraham." Be expressive. For example, say: *I am Abraham. You need to follow me and do whatever I do. First, you need to get dressed in a costume like mine.*
2. Help the children dress in their robes or sheets. Tie the sheets around the children's waists.
3. Help each of the children with their headpieces. If you are using scarves, tie them around the children's heads. If you are using towels, tie them with scarves.
4. After the children are in costume, have them repeat whatever "Abraham" does. If Abraham skips, the children skip. When Abraham does knee bends, the children do knee bends.
5. If time permits, the teacher could select a child to be Abraham, and the children could follow the new Abraham.

### Teacher Tips

- Have the children sit down as you hand out the costumes.
- If space is limited, you can sit down and play the game. If you do sit when playing, use more hand gestures and movements.



### Bible Walkman

The children will be reminded to closely "listen" to God.

#### Materials

*For each child:*

- 2 pieces of cardboard, 3" x 5" for the Walkman
- 1 circular piece of cardboard, 3" for a speaker
- 2 pieces of black construction paper, 3" x 5"
- 2 pieces of black yarn, 16" and 9" lengths
- stickers
- 2 white narrow self-stick labels
- glue stick
- crayons

*For the teacher:*

- scissors

#### Preparation

1. Cut out all cardboard and construction paper for each child.
2. Tie the yarn to make earphones, as shown in Figure A.
3. On one label, write the memory scripture, "This is love for God: to obey his commands. 1 John 5:3." On the other label, write "Bible FM."
4. Make a model of the craft following the instructions.
5. Keep your model of the craft for Unit 2 Lesson 7.

#### Instructions

1. Have the children glue the two rectangular pieces of cardboard together and then glue the black construction paper onto both sides of the cardboard. See Figure B.
2. Have the children glue their cardboard speakers onto the front of their Walkmans, as shown in Figure C.
3. Have the children put the "Bible FM" and memory scripture labels onto their Walkmans.
4. Help the children tape the "headphones" to one side of their Walkmans. See Figure D.
5. Give the children their stickers to decorate their Walkmans.
6. Demonstrate using the Walkman to "listen to God!"

#### Teacher Tips

- Be sure to make a model before class so the children can see what they are making.
- Let the children be creative and change things if they would like.

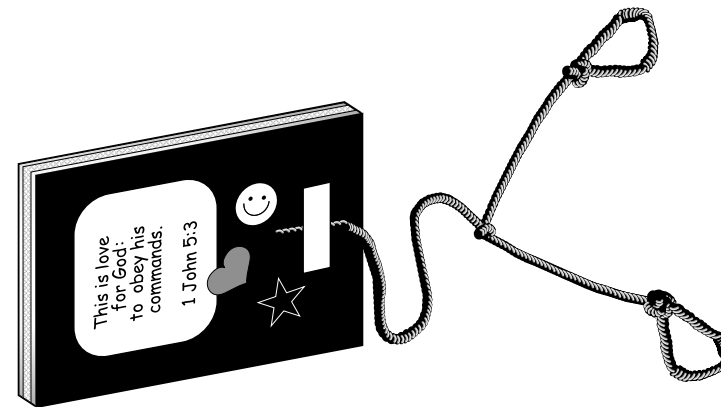

# Abraham and Sarah

## Obedience

### Lesson 4

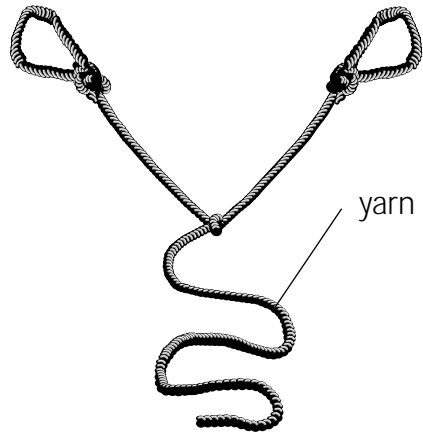

Figure A

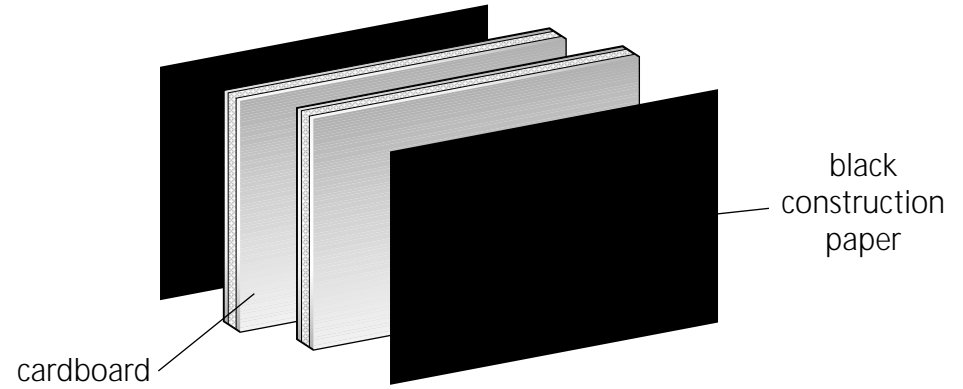

Figure B

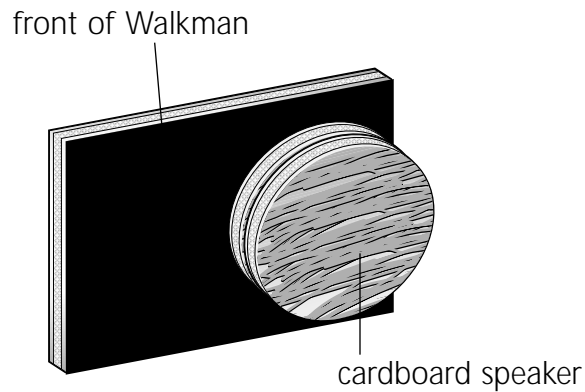

Figure C

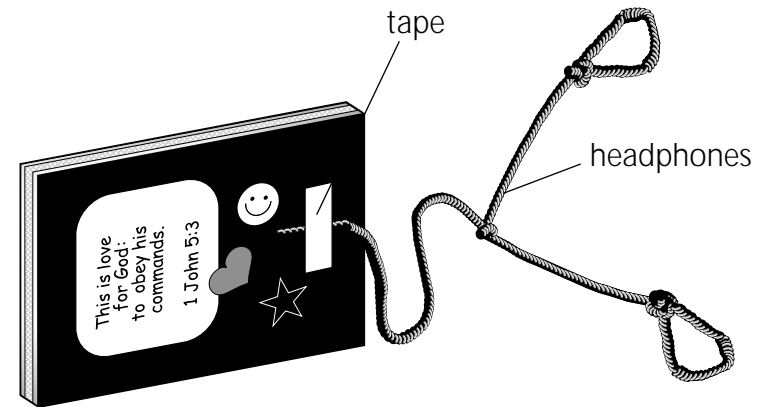

Figure D



# Abraham and Sarah

## Obedience

### Lesson 4

### Blind Man's Trust

The children will learn the concepts of trust and obedience by being blindfolded and led by a teacher.

#### Scripture Memory Verse

This is love for God: to obey his commands.

1 John 5:3

#### Materials

For the teacher:

- a scarf or piece of cloth for the blindfold

#### Preparation

If possible, the teacher should practice this activity with a child.

#### Instructions

1. Blindfold the first child and direct him by taking his hand and giving him instructions such as: *Move two steps forward, then turn toward my voice and go four steps*, etc. Many children will not know "right" from "left" so be sure to lead them by the hand.
2. Give each child a turn being blindfolded and guided.
3. Have the children talk about how they felt while they were blindfolded. Ask them the following questions:
  - *Did you know where you were going?*
  - *Was it easy for you to obey?*
  - *How did you feel about not knowing where you were going?* (express that this was probably how Abraham felt)

#### Scripture Memory Activity

To use time effectively, have each child recite the memory scripture before taking a turn being blindfolded.

#### Conclusion

Ask the following questions for discussion and review.

- *Who in the Bible did not obey God when God told him to do something?* (Adam)
- Review how Adam and Eve listened to the serpent and did not trust and obey God. *Did Adam and Eve listen to God or to Satan?* (Satan)
- *Why did Adam and Eve disobey God?* (They did what they wanted to do even though God said not to do it.)
- *Abraham was different, though. How was Abraham not like Adam and Eve?* (He listened to God, and he obeyed even though he did not understand where he was going.)
- *What are some ways that you can be like Abraham at home?* Have the children describe ways that they can obey when they're told the first time, such as going to bed, cleaning their rooms, coming to dinner, etc.
- *How do you feel when you obey?* (happy)

*Sometimes it is hard to obey because we don't understand what someone is asking us to do or we just don't want to listen to them. But God says that if we obey it makes us happy. Our friends need to know that being obedient will make them happy. Who do you know that needs to hear that obedience will make them happy? Let's ask God to help us to be obedient. Choose a child to pray.*

#### Teacher Tips

You may not have enough time to ask all the questions. Be sure to give each child a turn to be blindfolded and then ask the first four questions. Go on to the rest of the questions only if time permits.



This Is Love for God:  
to Obey His  
Commmands.

1 John 5:3



Core/Bible Story

1 copy for the teacher

**OBEDIENCE**

Page

**A**



Abraham and Sarah

