



**COMMERCIAL  
PRODUCT SPECIFICATIONS**



SMARTWIRE™ SYSTEM



**ASHRAE 90.1  
COMPLIANT**

**13 to 25 Tons**  
**Net Cooling Capacity - 150,000 to 270,000 Btuh**  
**Gas Input Heat Capacity - 169,000 to 480,000 Btuh**

**MODEL NUMBER IDENTIFICATION**

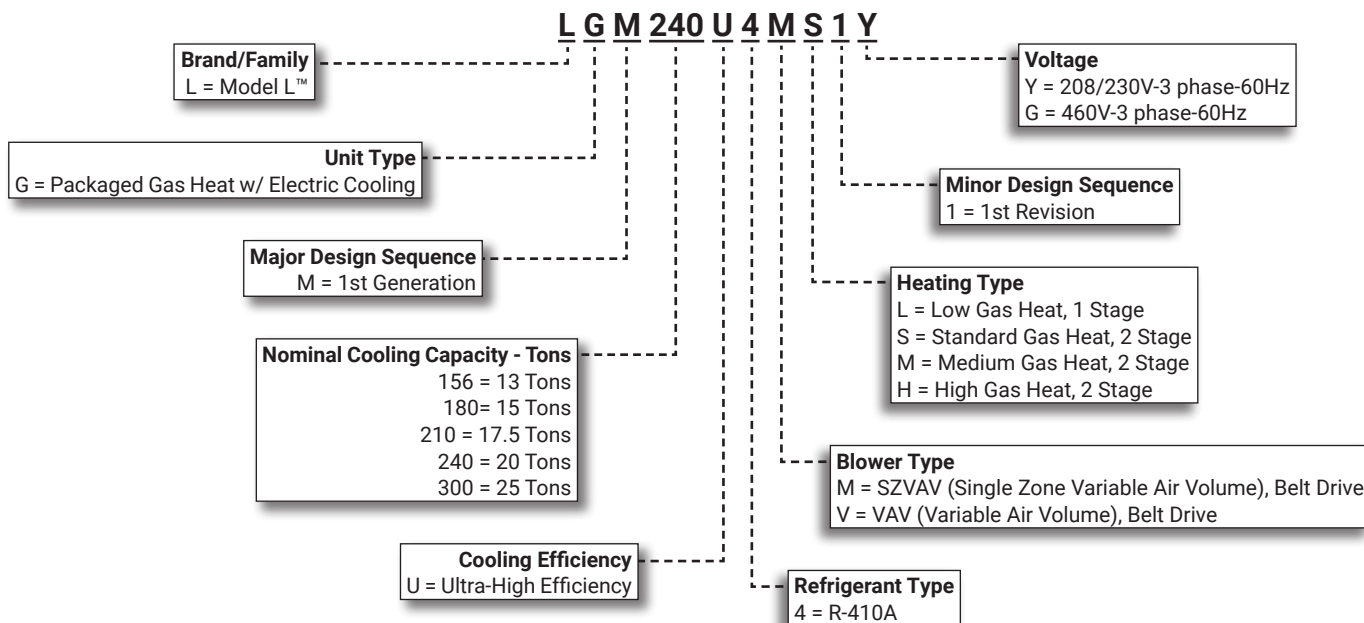

## FEATURE HIGHLIGHTS

The Model L™ packaged rooftop line is engineered with advanced variable speed technology to offer some of the highest energy efficiencies in the industry while delivering superior temperature and humidity control in a wide variety of commercial applications.

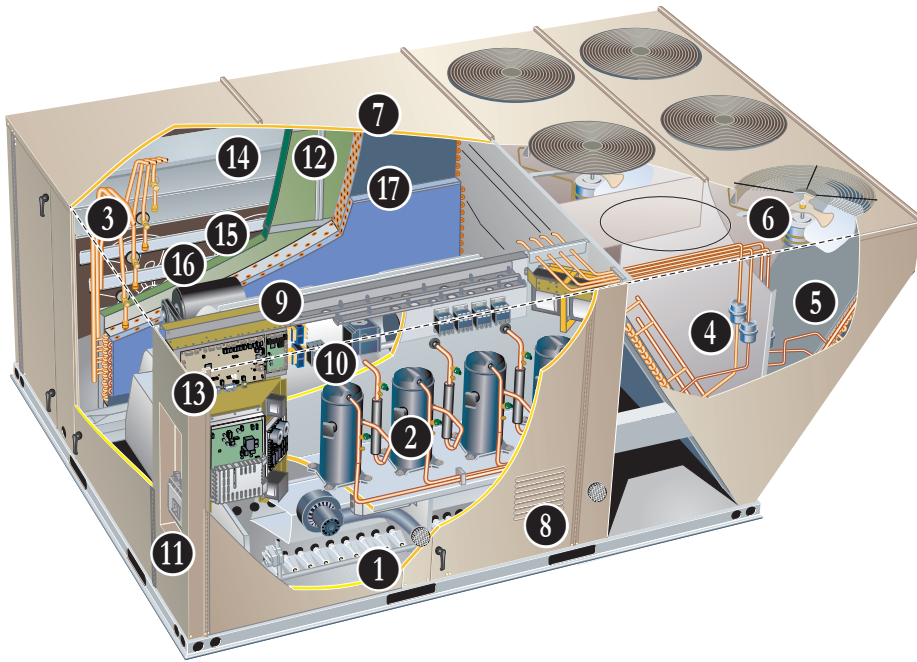

1. Aluminized Steel Inshot Burners
2. Variable Capacity Scroll Compressor (1) and Fixed Capacity Scroll Compressors (2 or 3)
3. Thermal Expansion Valves
4. Filters/Driers
5. Condenser Coil
6. Variable-Speed ECM Outdoor Coil Fan Motors (4) 156-180 and (6) 210-300
7. Heavy-Gauge Steel Cabinet
8. Hinged Access Panels
9. Supply Air Blower
10. Variable Frequency Drive (VFD)
11. Disconnect Switch (option)
12. Air Filters
13. Lennox® CORE Control System
14. Economizer (option)
15. Downflow Barometric Relief Dampers (option)
16. Power Exhaust Fans (option)
17. Humiditrol™+ Dehumidification System

## CONTENTS

Approvals And Warranty . . . . .	3
Blower Data . . . . .	33
Control System . . . . .	8
Cooling Ratings . . . . .	27
Dimensions . . . . .	42
- LGM156   LGM180 . . . . .	42
- LGM210   LGM240   LGM300 . . . . .	43
- Accessories . . . . .	44
Electrical Data . . . . .	36
- 13 Ton . . . . .	36
- 15 Ton . . . . .	36
- 17.5 Ton . . . . .	37
- 20 Ton . . . . .	37
- 25 Ton . . . . .	38
Features And Benefits . . . . .	3
High Altitude Derate . . . . .	26
Humiditrol™+ Dehumidification System Option . . . . .	12
Humiditrol™+ Dehumidification System Ratings . . . . .	32
Model Number Identification . . . . .	1
Optional Conventional Temperature Control Systems . . . . .	14
Options / Accessories . . . . .	19
Outdoor Sound Data . . . . .	40
Sequence Of Operation . . . . .	16
Specifications . . . . .	23
- 13 Ton . . . . .	23
- 15 Ton   17.5 Ton . . . . .	24
- 20 Ton   25 Ton . . . . .	25
Specifications - Gas Heat . . . . .	26
Weight Data . . . . .	41
- Unit . . . . .	41
- Options / Accessories . . . . .	41

## APPROVALS AND WARRANTY

### APPROVALS

- AHRI Standard 340/360 certified
- ETL and CSA listed
- CSA certified energy ratings
- Unit and components ETL, NEC, and CEC bonded for grounding to meet safety standards for servicing
- All models are ASHRAE 90.1 compliant
- All models meet California Code of Regulations, Title 24 requirements for staged airflow
- ISO 9001 Registered Manufacturing Quality System
- ENERGY STAR® certified

### WARRANTY

- Aluminized Steel Heat Exchanger - Limited ten years
- Optional Stainless Steel Heat Exchanger - Limited fifteen years
- Compressors - Limited five years
- Lennox® CORE Unit Controller - Limited three years
- Optional High Performance Economizers - Limited five years
- All other covered components - Limited one year

## FEATURES AND BENEFITS

### HEATING SYSTEM

#### 1 Heat Exchanger

- Tubular construction, aluminized steel
- Life-cycle tested

**NOTE** - Optional Stainless Steel Heat Exchanger is required if mixed air temperature is below 45°F.

- Aluminized steel inshot burners
- Direct spark ignition
- Electronic flame sensor
- Combustion air inducer
- Redundant automatic dual stage gas valve with manual shut-off

#### Electronic Pilot Ignition

- Electronic spark igniter provides positive direct ignition of burners on each operating cycle
- Permits main gas valve to stay open only when the burners are proven to be lit
- If loss of flame occurs, gas valve closes, shutting off the gas to the burners
- LED indicates status and aids in troubleshooting
- Watchguard circuit on module automatically resets ignition controls after one hour of continuous thermostat demand after unit lockout, eliminating nuisance service calls
- Factory installed in the gas heating compartment

#### Limit Controls

- Redundant limit controls with fixed temperature setting
- Protects heat exchanger and other components from overheating

#### Safety Switches

- Flame roll-out switch
- Flame sensor

- Combustion air inducer proving switch
- Protects system operation

### Required Selections

#### Gas Input Choice - Order one:

- Low Gas Heat, 1 Stage (169,000 Btuh)
- Standard Gas Heat, 2 Stage (169,000/260,000 Btuh)
- Medium Gas Heat, 2 Stage (234,000/360,000 Btuh)
- High Gas Heat, 2 Stage (312,000/480,000 Btuh)

**NOTE** – Two-stage heat models can be operated with four stages of gas heating when controlled in either room sensor, Discharge Air Control, or fresh air tempering mode on the Lennox® CORE Unit Controller (available when using the CS8500 thermostat or when connected to Building Automation Systems using BACnet, LonTalk, or S-Bus protocols). See Gas Heating Specifications table.

### Options/Accessories

#### Factory Installed

##### Stainless Steel Heat Exchanger

- Required if mixed air temperature is below 45°F

#### Factory or Field Installed

##### Bottom Gas Piping Kit

- Allows bottom gas entry
- Factory installed kit is furnished with the unit for field installation

##### Low Temperature Vestibule Heater

- Electric heater automatically controls minimum temperature in gas burner compartment when temperature is below -40°F
- CSA certified to allow operation of unit down to -60°F

## FEATURES AND BENEFITS

### HEATING SYSTEM (continued)

#### Field Installed

##### Combustion Air Intake Extensions

- Recommended for use with existing flue extension kits in areas where high snow can block intake air
- Order two kits

##### LPG/Propane Kits

- Conversion kit to field change over units from Natural Gas to LPG/Propane
- Order two kits

##### Vertical Vent Extension Kit

- Use to exhaust flue gases vertically above unit
- Required when unit vent is too close to fresh air intakes per building codes
- Also prevents ice formation on intake louvers
- Kit contains vent transition, vent tee, drain cap and installation hardware

**NOTE** - Straight vent pipes (4 in. B-Vent) and caps are not furnished and must be field supplied. Refer to kit instructions for additional information.

### COOLING SYSTEM

- Designed to maximize sensible and latent cooling performance at design conditions
- System can operate from 0°F to 125°F without any additional controls

#### R-410A Refrigerant

- Non-chlorine based
- Ozone friendly

#### **2** Multiple Compressors

Cooling system consists of one variable capacity scroll compressor and multiple fixed capacity scroll compressors (two for 156-180 models, three for 210-300 models)

##### Variable Capacity Scroll Compressor

- High performance, reliability and quiet operation
- Operates on a variable frequency determined to vary capacity based on the cooling load required

##### Fixed Capacity Scroll Compressors

- High performance, reliability and quiet operation
- Resiliently mounted on rubber grommets for quiet operation

##### DC Inverter Control (for Variable Capacity Compressor)

- Converts AC line voltage into filtered variable DC voltage
- Provides continuous compressor operation, while adjusting the capacity according to discharge air temperature
- Adjusts compressor output in increments as small as 1%
- Prevents frequent changes in capacity and ensures efficient, economical operation
- Power Factor Correction (PFC) circuit monitors the DC bus for high, low and abnormal voltage conditions to protect the compressor

- Two LEDs (red and green) indicate inverter operating status and aid in troubleshooting
- Noise filter reduces unwanted electromagnetic interference (EMI)
- Inverter reactor adds inductance to the line between the inverter and the compressor to limit current rise and protect the compressor

##### Compressor Crankcase Heaters

- Protects against refrigerant migration that can occur during low ambient operation or during extended off cycles

#### **3** Thermal Expansion Valves

- Ensures optimal performance throughout the application range
- Removable element head

#### **4** Filter/Driers

- High capacity filter/drier protects the system from dirt and moisture

##### High Pressure Switches

- Protects the compressors from overload conditions such as dirty condenser coils, blocked refrigerant flow, or loss of outdoor fan operation

##### Low Pressure Switches

- Protects the compressors from low pressure conditions such as low refrigerant charge, or low/no airflow

##### Diagnostic and Sensor System

- Multiple thermistors continuously monitor the refrigeration system, providing optimum performance and complete circuit protection at all operating conditions

##### Indoor Coil Freeze Protection

- Protects the evaporator coil from damaging ice build-up due to conditions such as low/no airflow, or low refrigerant charge

#### **5** Condenser Coil

- Copper tube construction
- Enhanced rippled-edge aluminum fins
- Flared shoulder tubing connections
- Silver soldered construction

##### Evaporator Coil

- Copper tube construction
- Enhanced rippled-edge aluminum fins
- Flared shoulder tubing connections
- Silver soldered construction for improved heat transfer
- Factory leak tested
- Cross row circuiting with rifled tubing optimizes both sensible and latent cooling capacity

##### Anti-Microbial Condensate Drain Pan

- Plastic pan, sloped to meet drainage requirements per ASHRAE 62.1
- Anti-Microbial additive resists growth of mold and mildew on drain pan, which improves indoor air quality and reduces drain line blockage
- Side or bottom drain connections

## FEATURES AND BENEFITS

### **COOLING SYSTEM (continued)**

- 6** Variable-Speed ECM Outdoor Coil Fan Motors
- Fan speed is directly controlled by the Lennox® CORE Unit Controller
  - Thermal overload protected
  - Totally enclosed
  - Permanently lubricated ball bearings
  - Shaft up
  - Wire basket mount

#### **Outdoor Coil Fans**

- PVC coated fan guards furnished

#### **Required Selections**

##### **Cooling Capacity**

- Specify nominal cooling capacity

#### **Options/Accessories**

#### **Factory or Field Installed**

##### **Condensate Drain Trap**

- Constructed of PVC (factory or field) or copper (field only)

**NOTE** - Trap is field installed only; PVC version may be factory ordered to ship with unit.

##### **Drain Pan Overflow Switch**

- Monitors condensate level in drain pan
- Shuts down unit if drain becomes clogged

### **CABINET**

- 7** Construction
- Heavy-gauge steel panels
  - Full perimeter heavy-gauge galvanized steel base rail
  - Base rails have rigging holes
  - Three sides of the base rail have forklift slots
  - Raised edges around duct and power entry openings in the bottom of the unit for water protection

#### **Airflow Choice**

- Units are shipped in downflow (vertical) configuration

**NOTE** - Units can be field converted to horizontal air flow with optional Horizontal Return Air Panel Kit and Horizontal Roof Curb.

#### **Power/Gas Entry**

- Electrical and gas lines can be brought through the unit base or through horizontal access knock-outs

#### **Exterior Panels**

- Constructed of heavy-gauge, galvanized steel
- Textured pre-paint with polyurethane finish
- Cyclic salt fog and UV exposure up to 1680 hours per ASTM D5894

#### **Insulation**

- Fully insulated with non-hygroscopic fiberglass insulation (conditioned areas)
- Unit base is fully insulated
- Base insulation serves as an air seal to the roof curb, eliminating the need to add a seal during installation

**8** **Hinged Access Panels**

- Filter section
- Blower section
- Heating section
- Compressor/controls section
- Panel seals and quarter-turn latching handles provide a tight air and water seal

#### **Required Selections**

##### **Airflow Configuration**

- Specify downflow or horizontal

#### **Options/Accessories**

#### **Factory Installed**

##### **Corrosion Protection**

- Completely flexible immersed coating
- Electrodeposited dry film process
- AST ElectroFin E-Coat
- Meets Mil Spec MIL-P-53084, ASTM B117 Standard Method Salt Spray Testing
  - Indoor Corrosion Protection:
    - Coated coil
    - Coated reheat coil (Humiditrol™+)
  - Painted blower housing
  - Painted indoor base
- Outdoor Corrosion Protection:
  - Coated coil
  - Painted outdoor base

#### **Field Installed**

##### **Combination Coil/Hail Guards**

- Heavy gauge steel frame
- Painted to match cabinet
- Expanded metal mesh protects outdoor coil

##### **Horizontal Return Air Panel Kit**

- Required for horizontal applications with Horizontal Roof Curb
- Contains panel with return air opening for field replacement of existing unit panel and panel to cover bottom return air opening in unit
- See dimension drawings

## FEATURES AND BENEFITS

### **BLOWER**

A wide selection of supply air blower options are available to meet a variety of airflow requirements

#### **Motor**

- Overload protected, equipped with ball bearings
- Belt drive motors are offered on all models and are available in several different sizes to maximize air performance

#### **Motor Efficiency**

- All blower motors 5 hp and above meet minimum energy efficiency standards in accordance with the Energy Independence and Security Act (EISA) of 2007

### **9 Supply Air Blower**

- Forward curved blades
- Double inlet
- Blower wheel is statically and dynamically balanced
- Ball bearings
- Adjustable pulley (allows speed change)
- Blower assembly slides out of unit for servicing
- Grease fittings furnished

#### **Supply Static Pressure Transducer (VAV Models Only)**

- Sends information to the Lennox® CORE Unit Controller to control VFD blower speed
- Shipped with the unit for remote field installation in the supply duct

### **Required Selections**

#### **Select SZVAV (Single Zone Variable Air Volume) or Variable Air Volume (VAV) Models**

- SZVAV (Single Zone Variable Air Volume) modulates the amount of airflow according to cooling demand, heating demand, ventilation demand or smoke alarm
  - Variable Air Volume (VAV) modulates the air volume to maintain a constant duct static pressure
- 10**
- Utilizes a Variable Frequency Drive (VFD) to modulate the supply blower airflow
    - VFD alters the frequency and voltage of the power supply to the blower to control blower speed
    - The amount of airflow for each stage can be set according to a parameter in the Lennox® CORE unit controller
    - Unit is shipped from the factory with preset airflows
    - SZVAV can be ordered with or without an Electronic Bypass Control
    - If equipped with the bypass control the SZVAV features manual (default) or automatic electronic bypass control of the VFD
    - In case of a VFD malfunction, a VFD alarm is generated by the Lennox® CORE unit controller
    - VFD can be manually bypassed to continue unit operation at full blower speed or the unit controller can be set to automatically switch to full blower speed if a VFD alarm is generated
    - VFD has an operational range of 0 to 125°F outdoor air ambient temperature

- Lower operating costs are obtained when the blower is operated on lower speeds

**NOTE** - Variable Frequency Drive (VFD) is designed to operate on balanced, three-phase power. Operating units on unbalanced three-phase power will reduce the reliability of all electrical components in the unit. Unbalanced power is a result of the power delivery system supplied by the local utility company. Factory-installed inverters are sized to drive blower motors with an equivalent current rating using balanced three-phase power. If unbalanced three-phase power is supplied; the installer must replace the existing factory-installed inverter with an inverter that has a higher current rating to allow for the imbalance. Refer to the installation instructions for additional information and replacement information.

#### **Ordering Information**

- Specify motor horsepower and drive kit number when base unit is ordered

### **Options/Accessories**

#### **Factory Installed**

##### **Blower Belt Auto-Tensioner**

- Provides proper tension to belt drive blower belt without the need for regular adjustments
- Maintains airflow and proper performance

#### **ELECTRICAL**

##### **SmartWire™ System**

- Advanced wiring connectors are keyed and color-coded to prevent miswiring
- Wire coloring scheme is standardized across all models
- Each connection is intuitively labeled to make troubleshooting and servicing quick and easy

##### **Electrical Plugs**

- Positive connection electrical plugs connect common accessories or maintenance parts for easy removal or installation

## FEATURES AND BENEFITS

### **ELECTRICAL (continued)**

#### Phase/Voltage Detection Phase

- Monitors power supply to ensure phase is correct at unit start-up
- If phase is incorrect, the unit will not start and an alarm code is reported to the unit controller
- Protects unit from being started with incorrect phasing which could lead to issues such as compressors running backwards
- Voltage detection monitors power supply voltage to ensure proper voltage
- If voltage is not correct (over/under voltage conditions) the unit will not start and an alarm code is reported to the unit controller

#### Required Selections

#### Voltage Choice

- Specify when ordering base unit

#### Options/Accessories

#### **Factory Installed**

##### Circuit Breakers

- HACR type
- For overload and short circuit protection
- Factory wired and mounted in the power entry panel
- Current sensitive and temperature activated
- Manual reset

##### Short-Circuit Current Rating (SCCR)

- Higher short circuit protection up to 100kA

#### **Factory or Field Installed**

#### **11** Disconnect Switch

- Accessible from outside of unit
- Spring loaded weatherproof cover furnished

#### GFI Service Outlets (2)

- 115V ground fault circuit interrupter (GFCI) type
- Available non-powered, field-wired or factory-wired and powered

#### **Field Installed**

##### GFI Weatherproof Cover

- Single-gang cover
- Heavy-duty UV-resistant polycarbonate case construction
- Hinged base cover with gasket

### **INDOOR AIR QUALITY**

#### **12** Air Filters

- Disposable 2 inch filters furnished as standard

#### Options/Accessories

#### **Factory or Field Installed**

##### Healthy Climate® High Efficiency Air Filters

- Disposable MERV 8, MERV 13 or MERV 16 (Minimum Efficiency Reporting Value based on ASHRAE 52.2) efficiency 2-inch pleated filters

### Healthy Climate® UVC Germicidal Lamps

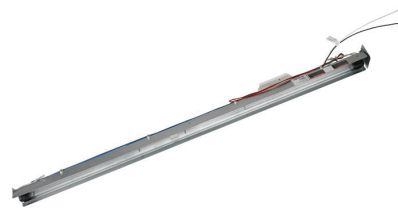

- Germicidal lamps emit ultra-violet (UV-C) energy, which has been proven to be effective in reducing microbes such as viruses, bacteria, yeasts, and molds
- This process either destroys the organism or controls its ability to reproduce
- UV-C energy greatly reduces the growth and proliferation of mold and other bioaerosols (bacteria and viruses) on illuminated surfaces (particularly coil and drain pan)
- Installed in the blower/evaporator coil section
- Safety interlock switch automatically shuts off power to the UVC light when panel is removed
- Interlock switch is factory installed or field installed in the blower/evaporator coil section panel
- All necessary hardware for installation is included
- Lamps operate on 110/230V, 1 phase power supply

**NOTE** - Step-down transformer may be ordered for field installed UVC lamps when used with 460V rooftop units. Step-down transformer is furnished with lamps when factory installed.

- Approved by ETL

#### **Needlepoint Bipolar Ionization (NPBI) Kit**

- NPBI technology integrates with system controls for effective air treatment
- Ionization has been shown to effectively reduce harmful pathogens, pollutants and odors

**NOTE** - Please visit [www.sciencedirect.com](http://www.sciencedirect.com) for additional information.

- Brush-type ionizer introduces a high concentration of both positive and negative ions into the airstream
- These bipolar ions are then dispersed into the occupied space through the duct system proactively reducing the airborne contaminants
- Ions travel within the building air stream and attach to particles, pathogens, and gas molecules, making them larger and easier to capture in the filtration system
- UL 2998 certified for zero ozone emission

#### **Field Installed**

##### Indoor Air Quality (CO<sub>2</sub>) Sensors

- Monitors CO<sub>2</sub> levels, reports to the Lennox® CORE Unit Controller which adjusts Economizer dampers as needed

##### Replacement Filter Media Kit With Frame

- Replaces existing pleated filter media
- Includes washable metal mesh screen and metal frame with clip for holding replaceable non-pleated filter

## CONTROL SYSTEM

### LENNOX® CORE CONTROL SYSTEM

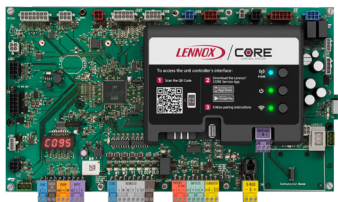

The Lennox® CORE Control System is designed to accelerate equipment install and service. Standard with all Model L™ rooftop units, control system integrates key technologies that lower installation costs, drive system efficiency, and protect your investments.

**13** The Lennox® CORE Unit Controller is a microprocessor-based controller that provides flexible control of all unit functions.

#### Wireless Service App Connectivity (Coming Soon to Android and iOS)

- Setup menu ensures proper installation and simplified setup of the rooftop unit
- Detailed data readout updates sensor values in real time and allows trending
- Unit self-test verifies individual critical component and system performance
- Economizer test function ensures Economizer is operating correctly

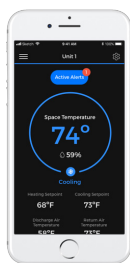

**NOTE** - Android or iOS device required.

#### Additional Features:

- Built-In 7-Segment Display shows Unit Status and active alarms for easy troubleshooting
- Buttons for test and clearing delays
- SmartWire™ System with keyed and removable screw terminals ensure correct field wiring
- Built-in BACnet MS/TP and IP allow open integration to building management systems.
- Two-port Ethernet Switch enables daisy chaining for BACnet IP and automatic firmware updates

**NOTE** - Unit Internet Connection required.

- Profile setup copies key settings between units with the same configuration to reduce setup time
- USB port allows a technician to download and transfer unit information to help verify service was performed
- USB software updates on the Lennox® CORE Unit Controller enhance functionality without the need to change components
- Unit Controller Software

#### Configurable Built-In Functions

- Full modulation of variable speed compressor for discharge air temperature control in room sensor or thermostat mode
- Discharge Air Cooling Control (Standard)
- Up to 3 distinct Cooling Airflows in Thermostat Mode with additional relay.
- Programmable independent heating, ventilation and cooling blower speeds

- Discharge Air Heating Control
- Economizer Control Options (See Economizer / Exhaust Air / Outdoor Air sections)
- Exhaust Fan Control Modes for fresh air damper position
- Configurable Morning Warm-up
- Night Setback Mode
- Fresh Air Tempering for Improved Ventilation
- Demand Control Ventilation
- Low Ambient Controls for operation down to 0°F
- Humiditrol™+ Operation (Variable Capacity Hot-Gas Reheat)
- Enhanced Dehumidification (Latent Demand Control without reheat)

#### Component Protection / Unit Safeguards:

- Compressor Time-Off Delay
- Adjustable Blower On/Off Delay
- Return Air Temperature Limit Control
- Safety Switch Input allows Controller to respond to a external safety switch trip
- Service Relay Output
- Thermostat Bounce Delay
- Smoke Alarm Mode has four choices (unit off, positive pressure, negative pressure, purge)
- "Strike Three" Protection
- Gas Valve Time Delay Between First and Second Stage
- Minimum Compressor Run Time

#### Control Methods / Interfaces:

- DDC and 24V Thermostat
- BACnet MS/TP and IP
- LONTalk (Factory and Field Option)
- Lennox SBUS
- Compatibility with Lennox Wireless Room Sensors
- Zone Temperature Sensor Input
- Dehumidistat and Humidity Sensor Inputs
- Indoor Air Quality Inputs (2)
- Built-in Control Parameter Defaults
- Permanent Diagnostic Code Storage
- Field Adjustable Control Parameters (Over 200 settings)
- Multiple Configurable Digital Inputs
- LED Indicators
- PC Interface connects the Lennox® CORE Unit Controller to a PC with the Lennox Unit Controller Software

**NOTE** - Lennox® CORE Control System features vary with the type of rooftop unit in which the control is installed.



## CONTROL SYSTEM

### LENNOX® CORE CONTROL SYSTEM (continued)

#### Control Options

#### Factory or Field Installed

##### Blower Proving Switch

- Monitors blower operation, shuts down unit if blower fails

##### Dirty Filter Switch

- Senses static pressure increase and issues alarm if necessary

##### Fresh Air Tempering

- Used in applications with high outside air requirements
- Controller energizes the first stage heat as needed to maintain a minimum supply air temperature for comfort, regardless of the thermostat demand
- When ordered as a factory option, sensor ships with the unit for field installation

##### Smoke Detector

- Photoelectric type
- Installed in supply air section, return air section or both sections
- Available with power board and single sensor (supply or return) or power board and two sensors (supply and return)
- Power board located in unit control compartment

##### Interoperability via BACnet® or LonTalk® Protocols

- Communication compatible with third-party automation systems that support the BACnet Application Specific Controller device profile, LonMark® Space Comfort Controller functional profile, or LonMark Discharge Air Controller functional profile

### COMMERCIAL CONTROL SYSTEMS

#### (Field Installed)

##### L Connection® Network Control System

- Complete building automation control system for single or multi-zone applications
- Options include local interface, software for local or remote communication, and hardware for networking other control functions
- See L Connection Network Control System Product Specifications Bulletin for details

##### After-Market DDC

- Novar® Unit Controller and options

##### Thermostats

- Control system and thermostat options, see page 14
- After-Market unit controller options

## OPTIONS / ACCESSORIES

### ECONOMIZER

- Economizer operation is set and controlled by the Lennox® CORE Unit Controller
- Simple plug-in connections from Economizer to unit controller for easy installation
- All Model L™ rooftop units are equipped with factory installed CEC Title 24 approved sensors for outside, return and discharge air temperature monitoring

**NOTE** - Optional sensors may be used instead of unit sensors to determine whether outdoor air is suitable for free cooling. See Options/Accessories table.

#### Factory or Field Installed

#### **14** High Performance Economizer

- Approved for California Title 24 building standards
- Low leakage dampers are Air Movement and Control Association International (AMCA) Class 1A Certified - Maximum 3 CFM per sq. ft. leakage at 1 in. w.g.
- ASHRAE 90.1 and IECC compliant
- Downflow or Horizontal with Outdoor Air Hood
- Outdoor Air Hood with mist elimination is included when Economizer is factory installed and is furnished with Economizer when ordered for field installation

**NOTE** - Downflow or horizontal economizer applications require optional Downflow or Horizontal Barometric Relief Dampers with Exhaust Hood.

- Gear-driven action
- High torque 24-volt fully-modulating spring return damper motor
- Return air and outdoor air dampers
- Plug-in connections to unit
- Stainless steel bearings
- Enhanced thermoplastic vulcanizate (TPV) seals
- Flexible stainless steel jamb seals

**NOTE** - High Performance Economizers are not approved for use with enthalpy controls in Title 24 applications.

**NOTE** - The Free Cooling setpoint for Title 24 applications must be set based on the Climate Zone where the system is installed. See Section 140.4 "Prescriptive Requirements for Space Conditioning Systems" of the California Energy Commission's 2019 Building Energy Efficiency Standards.

**NOTE** - Refer to Installation Instructions for complete setup information.

#### Differential Sensible Control

- Factory setting
- Uses outdoor air and return air sensors that are furnished with the unit
- The Lennox® CORE Unit Controller compares outdoor air temperature with return air
- When the outdoor air is below the configured setpoint and cooler than return air, the controller activates the Economizer

## OPTIONS / ACCESSORIES

### ECONOMIZER (continued)

#### Factory or Field Installed (continued)

**NOTE** - Differential Sensible Control can be configured in the field to provide Offset Differential Sensible Control or Single Sensible Control.

**NOTE** - In Offset Differential Sensible Control mode, the Economizer is enabled if the temperature differential (offset) between outdoor air and return air reaches the configured setpoint. In Single Sensible Control mode, the Economizer is enabled when outdoor air temperature falls below the configured setpoint.

#### Global Control

- The unit controller communicates with a DDC system with one global sensor (enthalpy or sensible)
- Determines whether outside air is suitable for free cooling on all units connected to the control system
- Sensor must be field provided

#### Single Enthalpy Temperature Control (Not for Title 24)

- Outdoor air enthalpy sensor enables Economizer if the outdoor enthalpy is less than the setpoint of the control

#### Differential Enthalpy Control (Not for Title 24)

- Order two Single Enthalpy Controls
- One is field installed in the return air section
- One is installed in the outdoor air section
- Allows the Economizer control to select between outdoor air or return air, whichever has lower enthalpy

#### Field Installed

##### Outdoor Air CFM Control

- Maintains constant outdoor air volume levels on the supply air fan and varying unit airflows
- Velocity sensor located in the rooftop unit outdoor air section, the Lennox® CORE Unit Controller changes the Economizer position to help minimize the effect of supply fan speed changes on outdoor air volume levels
- Setpoint for outdoor air volume is established by field testing

**NOTE** - Not available with Demand Control Ventilation (CO<sub>2</sub> Sensor) or Building Pressure Control.

##### Building Pressure Control

- Maintains constant building pressure level
- Includes a static pressure transducer and outdoor static pressure assembly
- Using differential pressure information between the outdoor air and the building air, the Lennox® CORE Unit Controller changes the Economizer position to help maintain a constant building pressure

**NOTE** - Not available with Demand Control Ventilation (CO<sub>2</sub> Sensor) or Outdoor Air CFM Control.

### EXHAUST

#### Factory or Field Installed

##### **15** Downflow Barometric Relief Dampers

- Allow relief of excess air
- Aluminum blade dampers prevent blow back and outdoor air infiltration during off cycle
- Exhaust hood is factory installed when dampers are factory installed with Economizer
- Exhaust hood is furnished with dampers when ordered for field installation
- Bird screen furnished

##### **16** Power Exhaust Fans

- Install internal to unit for downflow applications only with Economizer option
- Provides exhaust air pressure relief
- Interlocked to run when supply air blower is operating
- Fans run when outdoor air dampers are 50% open (adjustable)
- Motor is overload protected
- Dual propeller type fans are 20 in. diameter
- Five blades
- Two 1/3 hp motors

**NOTE** - Requires Economizer with furnished Outdoor Air Hood and Downflow Barometric Relief Dampers.

**NOTE** - SZVAV (Single Zone Variable Air Volume) and VAV (Variable Air Volume) models are equipped with 2-stage power exhaust fans. Power exhaust operates in 1st stage (one fan) up to 70% of supply air blower speed. Both exhaust fans operate in 2nd stage when supply air blower speed is above 70% (adjustable) of full speed.

#### Field Installed

##### Horizontal Barometric Relief Dampers

- For use when unit is configured for horizontal applications requiring an Economizer
- Allows relief of excess air
- Aluminum blade dampers prevent blow back and outdoor air infiltration during off cycle
- Field installed in return air duct
- Bird screen and hood furnished

## OPTIONS / ACCESSORIES

### **OUTDOOR AIR OPTIONS**

#### **Factory or Field Installed**

##### **Outdoor Air Damper**

- Downflow or Horizontal
- Linked mechanical dampers
- 0 to 25% (fixed) outdoor air adjustable
- Installs in unit
- Includes outdoor air hood
- Automatic model features fully modulating spring return damper motor with plug-in connection
- Manual model features parallel blade, gear-driven dampers with adjustable fixed position

#### **ROOF CURBS**

##### **Field Installed**

- Nailer strip furnished (downflow only)
- Mates to unit
- US National Roofing Contractors Approved
- Shipped knocked down

##### **Downflow**

##### **Hybrid Roof Curbs**

- Interlocking tabs fasten corners together
- No tools required
- Can also be fastened together with furnished hardware
- Available in 8, 14, 18, and 24 inch heights

##### **Adjustable Pitch Curb**

- Fully adjustable pitch curbs (3/4 in. per foot in any direction) provide a level platform for rooftop units allowing flexible installations on roofs with uneven or sloped angles
- Interlocking tabs fasten corners together
- No tools required
- Hardware is furnished to connect upper curb with lower curb
- Available in 14 inch height

##### **Horizontal**

- Meet National Roofing Code requirements
- Converts unit from downflow to horizontal (side) air flow
- Return air is on unit, supply air is on curb
- See dimension drawings
- Available in 26, 30, 37 and 41 inch heights

**NOTE** - Requires Horizontal Return Air Panel Kit.

**NOTE** - Optional Insulation Kit is available to help prevent sweating.

##### **Adaptor Curbs (not shown)**

- Curbs are regionally sourced
- Dimensions vary based upon the source

**NOTE** - Contact your local sales representative for a detailed cut sheet with applicable dimensions.

### **CEILING DIFFUSERS**

#### **Field Installed**

##### **Ceiling Diffusers**

##### **(Flush or Step-Down)**

- White powder coat finish on diffuser face and grilles
- Insulated UL listed duct liner
- Diffuser box has collars for duct connection
- Step-down diffusers have double deflection blades
- Flush diffusers have fixed blades
- Provisions for suspending
- Internally sealed to prevent recirculation
- Removable return air grille
- Adapts to T-bar ceiling grids or plaster ceilings

##### **Transitions (Supply and Return)**

- Used with diffusers
- Installs in roof curb
- Galvanized steel construction
- Flanges furnished for duct connection to diffusers
- Fully insulated

## HUMIDITROL™+ DEHUMIDIFICATION SYSTEM OPTION

### OVERVIEW

- Factory installed option designed to control humidity
- 17 • Humiditrol™+ utilizes advanced control algorithms, variable speed technology and a reheat coil to efficiently control humidity levels independent of room temperature
- Provides dehumidification on demand using ASHRAE 90.1 recommended method for comfort conditioning humidity control
- Unit comes equipped with one row reheat coil and solenoid valve

**NOTE** - A dehumidification demand from a relative humidity sensor, dehumidistat, a DDC controller or building automation system is required to control humidity

### BENEFITS

- Improves indoor air quality
- Discharge air control for overcool protection
- Adjustable discharge air temperature setpoint
- Energy efficient dehumidification
- Modulating latent and sensible capacity
- Helps prevent damage due to high humidity levels
- Improves comfort levels by reducing space humidity levels

### OPERATION

#### **No Dehumidification Demand**

- The unit will operate conventionally whenever there is a demand for cooling or heating and no dehumidification demand
- Free cooling is only permitted when there is no demand for dehumidification

#### **Dehumidification Demand Only**

- Reheat operation will initiate on a dehumidification demand and does not require a cooling demand
- The unit will operate in hot gas reheat dehumidification mode until the relative humidity of the conditioned space is below the setpoint
- A solenoid valve diverts hot gas from the compressor to the reheat coil
- The cooled and dehumidified air from the evaporator is reheated as it passes through the reheat coil
- The de-superheated and partially condensed refrigerant continues to the outdoor condenser coil where condensing is completed
- Unit will continue to operate in this mode until the dehumidification demand is satisfied
- The reheat coil is sized to provide optimal reheat performance without overheating supply air
- The compressor will modulate based on dehumidification load
- The outdoor fans modulate speed to provide discharge air temperature control in reheat mode

#### **Dehumidification and Cooling Demand (Thermostat/ Room Sensor Application)**

- If both a dehumidification and a cooling demand occur, the system will operate in cooling until the cooling demand is satisfied
- Then the system will energize the dehumidification mode

**NOTE** - See Sequence of Operation for additional information.

# HUMIDITROL™ + DEHUMIDIFICATION SYSTEM OPTION

## REFRIGERANT SCHEMATIC (156U and 180U MODELS ONLY)

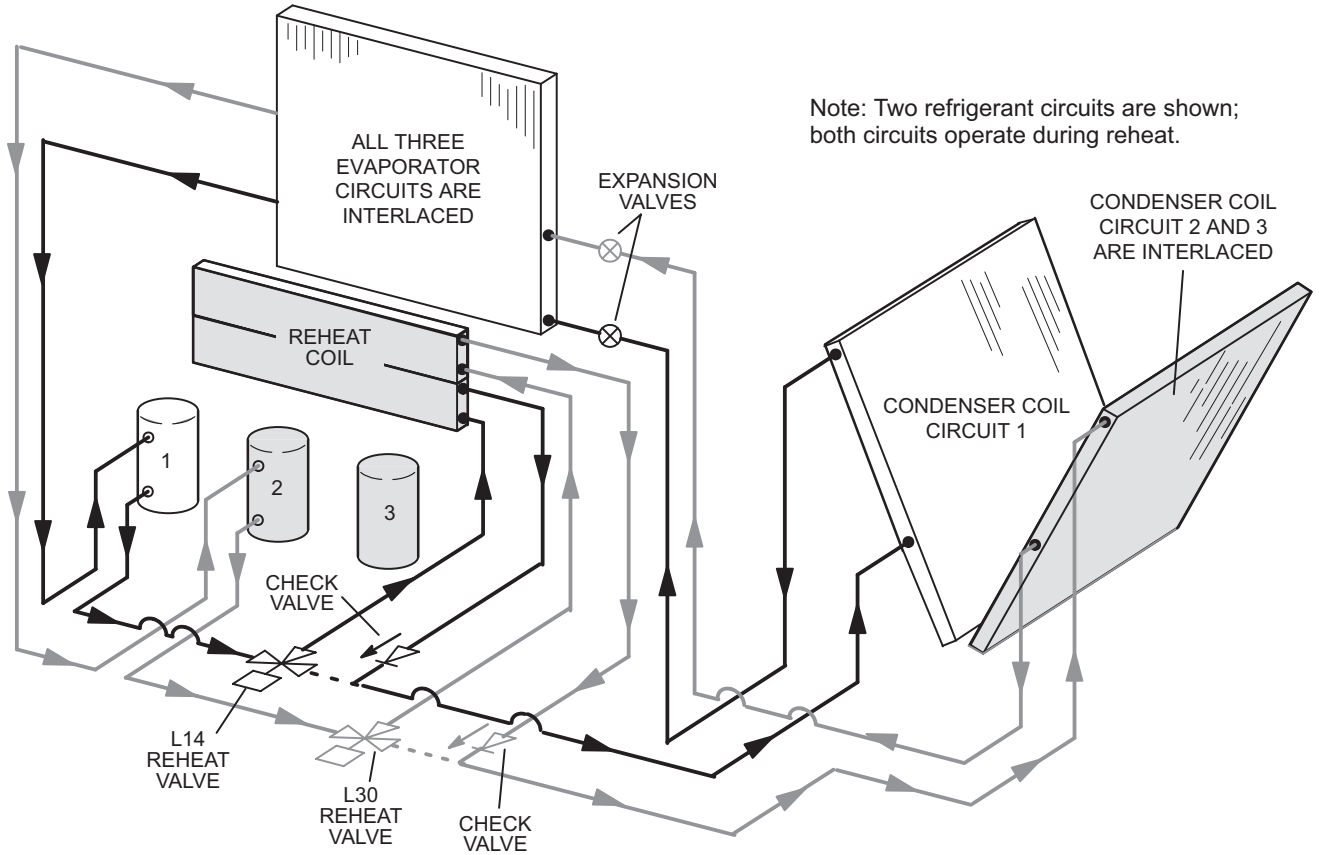

## REFRIGERANT SCHEMATIC (210U, 240U and 300U MODELS ONLY)

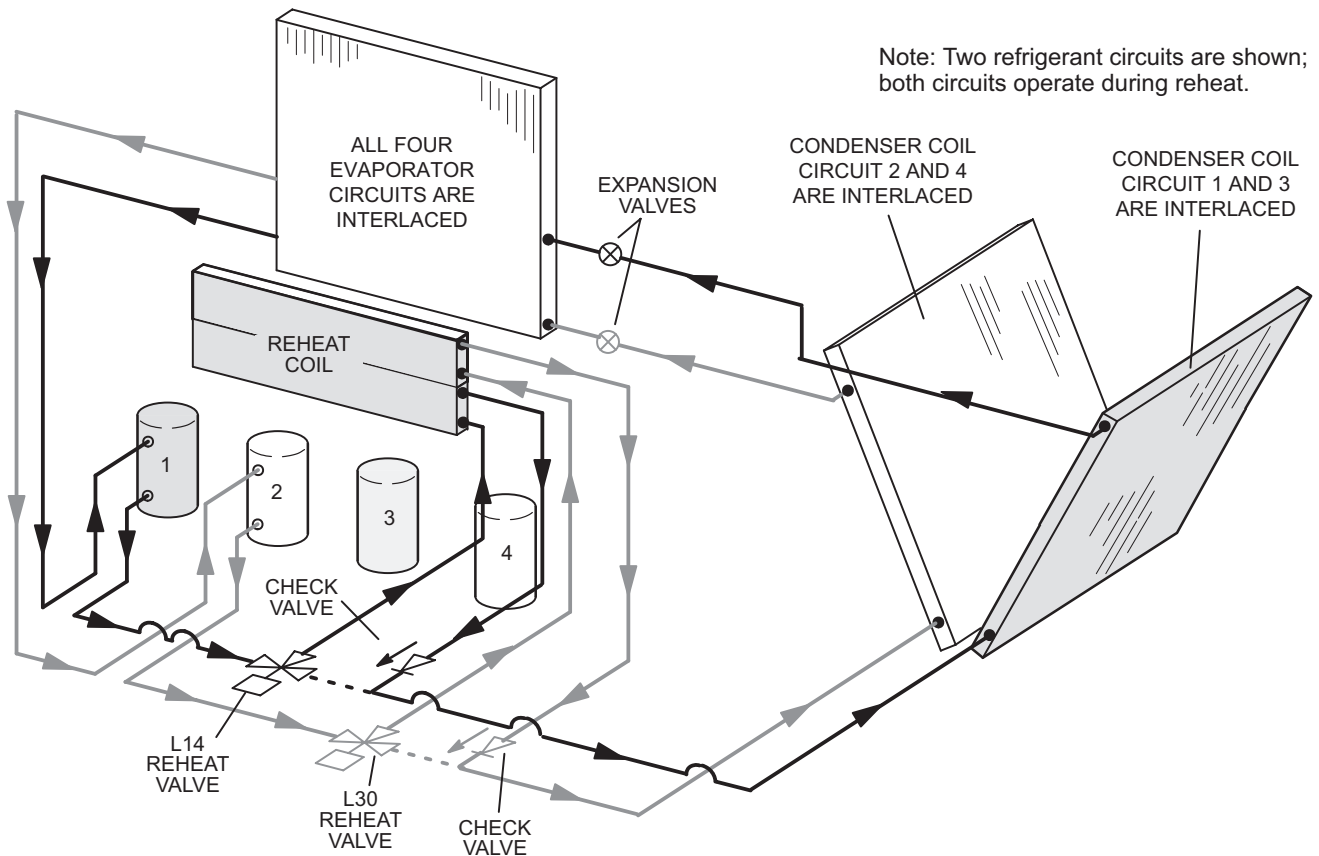

## OPTIONAL CONVENTIONAL TEMPERATURE CONTROL SYSTEMS

### ComfortSense® 8500 Commercial 7-Day Programmable Thermostat

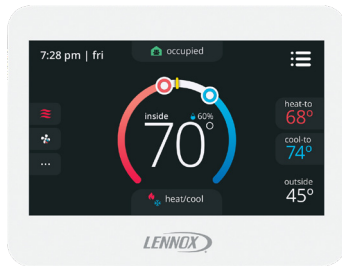

- Fully Communicating Sensor
- Full Color Touchscreen Interface
- Variable Speed System Control (On Compatible Units)
- Up To 4 Heat / 4 Cool
- Built-In Sensors For Temperature, Humidity And Optional CO<sub>2</sub>
- Remote Sensor Options For Occupancy, Temperature
- BACnet Capable Options
- 5-2 or 7-Day Scheduling
- Smooth Setback Recovery
- Heat/Cool Auto-Changeover
- Four-Wire Installation
- FDD, ASHRAE, IECC Compliant

### ComfortSense® 7500 Commercial 7-Day Programmable Thermostat



- Premium Universal Thermostat
- Full Color Touchscreen Interface
- Up To 4 Heat / 2 Cool
- Built-In Sensors For Temperature and Humidity
- Remote Sensors Options For Temperature, Discharge Air, Outdoor Air
- 5-2 or 7-Day Scheduling
- Smooth Setback Recovery
- Heat/Cool Auto-Changeover
- FDD, ASHRAE, IECC Compliant

### ComfortSense® 3000 Commercial 5-2 Day Programmable Thermostat

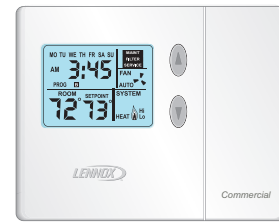

- Conventional Multi-Stage Thermostat
- Intuitive Display
- Push-Button Operation
- Up To 2 Heat / 2 Cool
- Built-In Temperature Sensor
- Remote Temperature Sensing
- Up to 5-2 Day Scheduling
- Smooth Setback Recovery
- Heat/Cool Auto-changeover

### Wireless/Wired Room Sensor (LCS-5030)



- Simple Push-Button Override
- Variable Speed System Control (On Compatible Units)
- Up To 4 Heat / 4 Cool
- Built-In Temperature and Humidity Sensors
- AA Battery / 24VAC Powered
- Bluetooth™ Mesh Operation
- SBUS Wired Operation
- Automatic Sensor Averaging
- Locking Hex Screw

### Wireless Repeater



- Extends Effective Range of Wireless Sensor
- 24VAC Only
- Locking Hex Screw

**NOTE** - Wireless only.

## OPTIONAL CONVENTIONAL TEMPERATURE CONTROL SYSTEMS

Description	Catalog No.
<b>ComfortSense® 8500 Commercial 7 Day Programmable Thermostat</b>	
CS8500 7-Day Thermostat	No CO <sub>2</sub> Sensing <b>17G75</b>
	With CO <sub>2</sub> Sensing <b>17G76</b>
Sensors/Accessories	<sup>1</sup> Remote non-adjustable wall-mount 10k <b>47W37</b>
	<sup>1</sup> Remote non-adjustable wall-mount 11k <b>94L61</b>
<b>Sysbus Network Cable (Yellow) for ComfortSense 8500 and LCS-5030 Wired Room Sensor</b>	
Twisted pair 100% shielded communication cable, Red and Black	500 ft. box <b>27M19</b>
22 AWG, yellow jacket, rated at 75°C, 300V, Plenum rated	1000 ft. box <b>94L63</b>
Insulation - Low smoke PVC, NEC, CMP	2500 ft. roll <b>68M25</b>
<b>ComfortSense® 7500 Commercial 7-Day Programmable Thermostat</b>	
CS7500 7-Day Thermostat	<b>17G74</b>
Sensors/Accessories	<sup>2</sup> Remote non-adjustable wall-mount 20k <b>47W36</b>
	<sup>2</sup> Remote non-adjustable wall-mount 10k <b>47W37</b>
	Remote non-adjustable discharge air (duct mount) <b>19L22</b>
	Outdoor temperature sensor <b>X2658</b>
<b>ComfortSense® 3000 Commercial 5-2 Day Programmable Thermostat</b>	
CS3000 5-2 Day Thermostat	<b>11Y05</b>
Sensors/Accessories	Remote non-adjustable wall mount 10k averaging <b>47W37</b>
	Thermostat wall mounting plate <b>X2659</b>
<b>ComfortSense® Non-Programmable Thermostat</b>	
CS3000 Non-Programmable Thermostat	<b>51M32</b>
<b>Universal Thermostat Guard with Lock (clear)</b>	
	Inside Dimensions (H x W) 5 7/8 x 8 3/8 in. <b>39P21</b>
<b>Wireless/Wired Room Sensor</b>	
LCS-5030 Wireless/Wired Room Sensor	<b>21L07</b>
	Wireless Repeater for Room Sensor - Temperature and humidity, no display <b>21L09</b>

<sup>1</sup> Up to nine of the same type remote temperature sensors can be connected in parallel.

<sup>2</sup> Remote wall-mount sensors can be applied in any of the following combinations:  
 One Sensor - (1) 47W36, Two Sensors - (2) 47W37, Three Sensors - (2) 47W36 and (1) 47W37  
 Four Sensors - (4) 47W36, Five Sensors - (3) 47W36 and (2) 47W37

## SEQUENCE OF OPERATION

### **COOLING**

#### **A-Two-Stage Thermostat**

1 - Economizer With Outdoor Air Suitable

##### **Y1 Demand**

- Compressors Off
- Blower Cooling Low
- Dampers Modulate

*NOTE - If dampers are at maximum open for five minutes, blower runs at cooling high.*

##### **Y2 Demand**

- Compressors Modulate
- Blower Cooling High
- Dampers Maximum Open

2 - No Economizer or Outdoor Air Not Suitable

##### **Y1 Demand**

- Compressors Modulate
- Blower Cooling Low
- Dampers Minimum Position

##### **Y2 Demand**

- Compressors Modulate
- Blower Cooling High
- Dampers Minimum Position

#### **B-Three-Stage Thermostat**

1 - Economizer With Outdoor Air Suitable

##### **Y1 Demand**

- Compressors Off
- Blower Cooling Low
- Dampers Modulate

*NOTE - If dampers are at maximum open for five minutes, blower runs at cooling intermediate.*

##### **Y2 Demand**

- Compressors Modulate
- Blower Cooling Intermediate
- Dampers Maximum Open

##### **Y3 Demand**

- Compressors Modulate
- Blower Cooling High
- Dampers Maximum Open



## SEQUENCE OF OPERATION

### COOLING (CONTINUED)

2 - No Economizer or Outdoor Air Not Suitable

#### **Y1 Demand**

- Compressors Modulate
- Blower Cooling Low
- Dampers Minimum Position

#### **Y2 Demand**

- Compressors Modulate
- Blower Cooling Intermediate
- Dampers Minimum Position

#### **Y3 Demand**

- Compressors Modulate
- Blower Cooling High
- Dampers Minimum Position

### **C - Room Sensor**

1 - Economizer With Outdoor Air Suitable

- Compressors Off
- Blower Modulates
- Dampers Modulate

*NOTE - If dampers are at maximum open for five minutes, compressors are energized and the blower modulates.*

2 - No Economizer or Outdoor Air Not Suitable

- Compressors Modulate
- Blower Modulates
- Dampers Minimum Position

*NOTE - Free cooling is locked out when a dehumidification demand is received. The unit operates in dehumidification.*

### HEATING

*NOTE - Heating Mode can be set to 2 stage in thermostat mode or at 4 stage in room sensor mode control options.*

#### **2 STAGE OPERATION:**

##### **W1 Demand:**

- Both gas valves are open on Low Fire (stage 1 on units with 2-stage gas valves) and supply air blower operates at heating speed

##### **W2 Demand:**

- Both gas valves are open on High Fire (stage 2 on units with 2-stage gas valves) and supply air blower operates at heating speed

#### **4 STAGE OPERATION:**

##### **W1 Demand:**

- Left heat exchanger gas valve is open on Low Fire (stage 1 on units with 4-stage gas valves) and supply air blower operates at heating speed

##### **W2 Demand:**

- Both gas valves are open on Low Fire (stage 2 on units with 4-stage gas valves) and supply air blower operates at heating speed

##### **W3 Demand:**

- Left heat exchanger gas valve will open on High Fire and the right heat exchanger will remain open on Low Fire (stage 3 on units with 4-stage gas valves) and supply air blower operates at heating speed

##### **W4 Demand:**

- Both gas valves are open on High Fire (stage 4 on units with 4-stage gas valves) and supply air blower operates at heating speed

## SEQUENCE OF OPERATION

### **HUMIDITROL™+**

#### **A - Thermostat Mode With 24V Humidistat**

Dehumidification Demand (DI4) and No Cooling Demand

Compressor 1 operates at 100% and reheat valve is energized, blower and outdoor fans modulate to maintain indoor coil and discharge air temperatures, all other compressors are off.

*NOTE: After 5 minutes of only a Dehumidification demand (DI4), compressor 2 is turned on and reheat valve is energized.*

Y1 and DI4 Demand

Compressors are modulating, blower is on cooling low, and the reheat valves are de-energized.

Y2 and DI4 Demand

Compressors are modulating, blower is on cooling high, and the reheat valves are de-energized.

#### **B - Thermostat Mode With Zone Relative Humidity Sensor**

Dehumidification Demand (RH% Setpoint < Zone RH% < RH% Setpoint +2%) and No Cooling Demand

Compressor 1 modulates based on zone relative humidity, blower and outdoor fans modulate to maintain indoor coil and discharge air temperatures, reheat valve is energized. All other compressors are off.

Dehumidification Demand (RH% Setpoint < Zone RH% for 5 minutes or Zone RH% > RH% Setpoint +2%) and No Cooling Demand

Compressor 1 modulates based on zone relative humidity and reheat valve is energized, Compressor 2 is on and reheat valve is energized, blower and outdoor fans modulate to maintain indoor coil and discharge air temperatures. All other compressors are off.

Y1 and Dehumidification Demand

Compressors are modulating, blower is on low, and the reheat valves are de-energized.

Y2 and Dehumidification Demand

Compressors are modulating, blower is on high, reheat valves are de-energized.

#### **C - Room Sensor Mode With 24V Humidistat**

Dehumidification Demand (DI4) and No Cooling Demand

Compressor 1 operates at 100%, blower and outdoor fans modulate to maintain indoor coil and discharge air temperatures, reheat valve is energized.

*NOTE: After 5 minutes of only a Dehumidification demand (DI4), compressor 2 is turned on and the reheat valve is energized.*

Cooling and Dehumidification Demand

Compressors are modulating, blower is modulating, reheat valves are de-energized.

#### **D - Room Sensor Mode With Zone Relative Humidity Sensor**

Dehumidification Demand (RH% Setpoint < Zone RH% < RH% Setpoint +2%) and No Cooling Demand

Compressor 1 modulates based on zone relative humidity, blower and outdoor fans modulate to maintain indoor coil and discharge air temperatures, reheat valve is energized. All other compressors are off.

Dehumidification Demand (RH% Setpoint < Zone RH% for 5 minutes or Zone RH% > RH% Setpoint +2%) and No Cooling Demand

Compressor 1 modulates based on zone relative humidity and reheat valve is energized, Compressor 2 is on and reheat valve is energized, blower and outdoor fans modulate to maintain indoor coil and discharge air temperatures. All other compressors are off.

Cooling and Dehumidification Demand

Compressors are modulating, blower is modulating, and the reheat valves are de-energized.

## OPTIONS / ACCESSORIES

Item Description	Catalog Number	Unit Model No					
		156	180	210	240	300	
<b>COOLING SYSTEM</b>							
Condensate Drain Trap	PVC	<b>22H54</b>	OX	OX	OX	OX	OX
	Copper	<b>76W27</b>	X	X	X	X	X
Corrosion Protection	Factory		O	O	O	O	O
Drain Pan Overflow Switch	<b>21Z07</b>		OX	OX	OX	OX	OX
Refrigerant Type	R-410A		O	O	O	O	O
Service Valves (not for Humiditrol™+ equipped units)	Factory		O	O	O	O	O
<b>HEATING SYSTEM</b>							
Bottom Gas Piping Kit	<b>85M31</b>		OX	OX	OX	OX	OX
Combustion Air Intake Extensions (order two)	<b>89L97</b>		X	X	X	X	X
Gas Heat Input	Low - 169,000 Btuh	Factory	O	O	O		
	Standard - 260,000 Btuh	Factory	O	O	O	O	O
	Medium - 360,000 Btuh	Factory	O	O	O	O	O
	High - 480,000 Btuh	Factory		O	O	O	O
Low Temperature Vestibule Heater	208/230V-3ph	<b>13X66</b>	OX	OX	OX	OX	OX
	460V-3ph	<b>13X67</b>	OX	OX	OX	OX	OX
LPG/Propane Conversion Kits (Order 2 kits)	Low Heat	<b>14N28</b>	X	X	X		
	Standard Heat	<b>14N28</b>	X	X	X	X	X
	Medium Heat	<b>14N29</b>	X	X	X	X	X
	High Heat	<b>14N30</b>		X	X	X	X
Stainless Steel Heat Exchanger	Factory		O	O	O	O	O
Vertical Vent Extension Kit (Order two kits)	<b>42W16</b>		X	X	X	X	X
<b>BLOWER - SUPPLY AIR</b>							
<b>Blower Option</b>							
	SZVAV (Single Zone Variable Air Volume) - With VFD Bypass Control	Factory	O	O	O	O	O
	SZVAV (Single Zone Variable Air Volume) - Without VFD Bypass Control	Factory	O	O	O	O	O
	VAV (Variable Air Volume) - Without VFD Bypass Control	Factory	O	O	O	O	O
Motors	Belt Drive (standard efficiency) - 2 hp	Factory	O				
	Belt Drive (standard efficiency) - 3 hp	Factory	O	O	O		
	Belt Drive (standard efficiency) - 5 hp	Factory	O	O	O	O	O
	Belt Drive (standard efficiency) - 7.5 hp	Factory		O	O	O	O
	Belt Drive (standard efficiency) - 10 hp	Factory				O	O
Drive Kits See Blower Data Tables for usage and selection	Kit #1 535-725 rpm	Factory	O	O	O		
	Kit #2 710-965 rpm	Factory	O	O	O		
	Kit #3 685-856 rpm	Factory	O	O	O	O	O
	Kit #4 850-1045 rpm	Factory	O	O	O	O	O
	Kit #5 945-1185 rpm	Factory	O	O	O	O	O
	Kit #6 850-1045 rpm	Factory		O	O	O	O
	Kit #7 945-1185 rpm	Factory		O	O	O	O
	Kit #8 1045-1285 rpm	Factory		O	O	O	O
	Kit #10 1045-1285 rpm	Factory				O	O
	Kit #11 1135-1365 rpm	Factory				O	O
	Blower Belt Auto-Tensioner	Factory	O	O	O	O	O

NOTE - Catalog numbers shown are for ordering optional accessories if a field installed option is available.

OX - Configure To Order (Factory Installed) or Field Installed

O = Configure To Order (Factory Installed)

X = Field Installed

## OPTIONS / ACCESSORIES

Item Description	Catalog Number	Unit Model No				
		156	180	210	240	300
<b>CONTROLS</b>						
Blower Proving Switch	<b>21Z10</b>	OX	OX	OX	OX	OX
Commercial Controls	LonTalk® Module - For Lennox® CORE Control System	<b>54W27</b>	OX	OX	OX	OX
	Novar® LSE Factory		O	O	O	O
	L Connection® Building Automation System	---	X	X	X	X
Dirty Filter Switch	<b>53W68</b>	OX	OX	OX	OX	OX
Fresh Air Tempering	<b>21Z08</b>	OX	OX	OX	OX	OX
Smoke Detector - Supply or Return (Power board and one sensor)	<b>83W40</b>	OX	OX	OX	OX	OX
Smoke Detector - Supply and Return (Power board and two sensors)	<b>83W41</b>	OX	OX	OX	OX	OX
<b>INDOOR AIR QUALITY</b>						
<b>Air Filters</b>						
Healthy Climate® High Efficiency Air Filters 24 x 24 x 2 in.	MERV 8 (Order 6)	<b>54W67</b>	OX	OX	OX	OX
	MERV 13 (Order 6)	<b>52W40</b>	OX	OX	OX	OX
	MERV 16 (Order 6)	<b>21U42</b>	OX	OX	OX	OX
Replacement Media Filter With Metal Mesh Frame 24 x 24 x 2 in. (includes non-pleated filter media)	(Order 6)	<b>44N61</b>	X	X	X	X
<b>Indoor Air Quality (CO<sub>2</sub>) Sensors</b>						
Sensor - Wall-mount, off-white plastic cover with LCD display	<b>77N39</b>	X	X	X	X	X
Sensor - Wall-mount, off-white plastic cover, no display	<b>87N53</b>	X	X	X	X	X
Sensor - Black plastic case with LCD display, rated for plenum mounting	<b>87N52</b>	X	X	X	X	X
Sensor - Wall-mount, black plastic case, no display, rated for plenum mounting	<b>87N54</b>	X	X	X	X	X
CO <sub>2</sub> Sensor Duct Mounting Kit - for downflow applications	<b>85L43</b>	X	X	X	X	X
Aspiration Box - for duct mounting non-plenum rated CO <sub>2</sub> sensors ( <b>87N53</b> or <b>77N39</b> )	<b>90N43</b>	X	X	X	X	X
<b>Needlepoint Bipolar Ionization (NPBI)</b>						
Needlepoint Bipolar Ionization (NPBI) Kit	<b>21U37</b>	OX	OX	OX		
	<b>21U38</b>				OX	
	<b>21U39</b>					OX
<b>UVC Germicidal Light Kit</b>						
<sup>1</sup> Healthy Climate® UVC Light Kit (110/230v-1ph)	<b>21A94</b>	OX	OX	OX	OX	OX
Step-Down Transformer	460V primary, 230V secondary	<b>10H20</b>	X	X	X	X
<b>ELECTRICAL</b>						
Voltage 60 Hz	208/230V - 3 phase	Factory	O	O	O	O
	460V - 3 phase	Factory	O	O	O	O
HACR Circuit Breakers		Factory	O	O	O	O
<sup>2</sup> Short-Circuit Current Rating (SCCR) of 100kA (includes Phase/Voltage Detection)		Factory	O	O	O	O
Disconnect Switch (see Disconnect Table for usage, page 39)	80 amp		OX	OX	OX	OX
	150 amp		OX	OX	OX	OX
	250 amp					OX
GFI Service Outlets	15 amp non-powered, field-wired (208/230V, 460V)	<b>74M70</b>	OX	OX	OX	OX
	15 amp factory-wired and powered (208/230V, 460V)	Factory	O	O	O	O
Weatherproof Cover for GFI		<b>10C89</b>	X	X	X	X

<sup>1</sup> Lamps operate on 110-230V single-phase power supply. Step-down transformer may be ordered separately for field installation in 460V rooftop units (transformer is furnished for factory installed lamp kit). Alternately, a separate 110V power supply may be used to directly power the UVC ballast(s).

<sup>2</sup> Disconnect Switch not available with higher SCCR option.

NOTE - Catalog numbers shown are for ordering optional accessories if a field installed option is available.

OX - Configure To Order (Factory Installed) or Field Installed

O = Configure To Order (Factory Installed)

X = Field Installed

## OPTIONS / ACCESSORIES

Item Description	Catalog Number	Unit Model No				
		156	180	210	240	300
<b>ECONOMIZER</b>						
<b>High Performance Economizer (Approved for California Title 24 Building Standards AMCA Class 1A Certified)</b>						
High Performance Economizer Downflow or Horizontal - Includes Outdoor Air Hood. NOTE - Order Downflow or Horizontal Barometric Relief Dampers separately.	<b>22J18</b>	OX	OX	OX	OX	OX
<b>Economizer Controls</b>						
Differential Enthalpy (Not for Title 24)	Order 2 <b>21Z09</b>	OX	OX	OX	OX	OX
Sensible Control	Sensor is Furnished Factory	O	O	O	O	O
Single Enthalpy (Not for Title 24)	<b>21Z09</b>	OX	OX	OX	OX	OX
Global Control	Sensor Field Provided Factory	O	O	O	O	O
Building Pressure Control	<b>13J77</b>	X	X	X	X	X
Outdoor Air CFM Control	<b>13J76</b>	X	X	X	X	X
<b>Barometric Relief Dampers With Exhaust Hood (required with economizer)</b>						
Downflow Barometric Relief Dampers	<b>54W78</b>	OX	OX	OX	OX	OX
Horizontal Barometric Relief Dampers	<b>16K99</b>	X	X	X	X	X
<b>OUTDOOR AIR</b>						
<b>Outdoor Air Dampers With Outdoor Air Hood</b>						
Motorized	<b>22J27</b>	OX	OX	OX	OX	OX
Manual	<b>13U05</b>	OX	OX	OX	OX	OX
<b>1 POWER EXHAUST (DOWNFLOW APPLICATIONS ONLY)</b>						
Standard Static, SCCR Rated	208/230V <b>22H90</b>	OX	OX	OX	OX	OX
	460V <b>22H91</b>	OX	OX	OX	OX	OX
<b>HUMIDITROL™+ HOT GAS REHEAT OPTION - SZVAV MODELS ONLY</b>						
Humiditrol+ Dehumidification Option	Factory	O	O	O	O	O
<b>CABINET</b>						
Combination Coil/Hail Guards	<b>13T12</b>	X	X	X	X	X

<sup>1</sup> Field installed Power Exhaust requires Economizer with Outdoor Air Hood and Downflow Barometric Relief Dampers with Exhaust Hood. Must be ordered separately.

NOTE - Catalog numbers shown are for ordering optional accessories if a field installed option is available.

OX - Configure To Order (Factory Installed) or Field Installed

O = Configure To Order (Factory Installed)

X = Field Installed

## OPTIONS / ACCESSORIES

Item Description	Catalog Number	Unit Model No				
		156	180	210	240	300
<b>ROOF CURBS</b>						
<b>Hybrid Roof Curbs, Downflow</b>						
8 in. height	<b>11F58</b>	X	X	X	X	X
14 in. height	<b>11F59</b>	X	X	X	X	X
18 in. height	<b>11F60</b>	X	X	X	X	X
24 in. height	<b>11F61</b>	X	X	X	X	X
<b>Adjustable Pitch Curb</b>						
14 in. height	<b>43W26</b>	X	X	X	X	X
<b>Standard Roof Curbs, Horizontal - Requires Horizontal Return Air Panel Kit</b>						
26 in. height - slab applications	<b>11T89</b>	X	X	X	X	
30 in. height - slab applications	<b>11T90</b>					X
37 in. height - rooftop applications	<b>11T96</b>	X	X	X	X	
41 in. height - rooftop applications	<b>11T97</b>					X
<b>Insulation Kit For Standard Horizontal Roof Curbs</b>						
for 26 in. height curb	<b>73K32</b>	X	X	X	X	
for 30 in. height curb	<b>73K33</b>					X
for 37 in. height curb	<b>73K34</b>	X	X	X	X	
for 41 in. height curb	<b>73K35</b>					X
<b>Horizontal Return Air Panel Kit</b>						
Required for Horizontal Applications with Roof Curb	<b>87M00</b>	X	X	X	X	X
<b>CEILING DIFFUSERS</b>						
Step-Down - Order one	RTD11-185S	<b>13K63</b>	X	X		
	RTD11-275S	<b>13K64</b>			X	X
Flush - Order one	FD11-185S	<b>13K58</b>	X	X		
	FD11-275S	<b>13K59</b>			X	X
Transitions (Supply and Return) - Order one	C1DIFF33C-1	<b>12X68</b>	X	X		
	C1DIFF34C-1	<b>12X70</b>			X	X

NOTE - Catalog numbers shown are for ordering optional accessories if a field installed option is available.

OX - Configure To Order (Factory Installed) or Field Installed

O = Configure To Order (Factory Installed)

X = Field Installed

**SPECIFICATIONS**

**13 TON**

<b>General Data</b>	<b>Nominal Tonnage</b>	<b>13 Ton</b>	<b>13 Ton</b>	
	<b>Model Number</b>	<b>LGM156U4M</b>	<b>LGM156U4V</b>	
	<b>Efficiency Type</b>	<b>Ultra-High</b>	<b>Ultra-High</b>	
	<b>Blower Type</b>	SZVAV (Single Zone Variable Air Volume)	VAV (Variable Air Volume)	
<b>Cooling Performance</b>	Gross Cooling Capacity - Btuh	154,000	154,000	
	<sup>1</sup> Net Cooling Capacity - Btuh	150,000	150,000	
	<sup>1</sup> AHRI Rated Air Flow - cfm	4250	4250	
	Total Unit Power - kW	12.5	12.5	
	<sup>1</sup> IEER (Btuh/Watt)	19.0	18.5	
	<sup>1</sup> EER (Btuh/Watt)	12.0	12.0	
<b>Refrigerant Charge</b>	<b>Refrigerant Type</b>		R-410A	
	Without Reheat	Circuit 1	16 lbs. 12 oz.	16 lbs. 12 oz.
		Circuit 2	9 lbs. 9 oz.	9 lbs. 9 oz.
		Circuit 3	9 lbs. 8 oz.	9 lbs. 8 oz.
	With Reheat	Circuit 1	21 lbs. 3 oz.	- - -
		Circuit 2	12 lbs. 8 oz.	- - -
		Circuit 3	9 lbs. 8 oz.	- - -
<b>Gas Heating Options Available</b>		See page 26		
<b>Compressor Type (number)</b>		Variable Capacity Scroll (1) Fixed Capacity Scroll (2)		
<b>Outdoor Coils</b>	Net face area (total) - sq. ft.	55.2	55.2	
	Tube diameter - in.	3/8	3/8	
	Number of rows	2	2	
	Fins per inch	20	20	
<b>Outdoor Coil Fans</b>	Motor - (No.) horsepower	(4) 1/3 ECM	(4) 1/3 ECM	
	Motor rpm	450-1075	450-1075	
	Total Motor watts	155 - 1150	155 - 1150	
	Diameter - (No.) in.	(4) 24	(4) 24	
	Number of blades	3	3	
	Total Air volume - cfm	16,000	16,000	
<b>Indoor Coils</b>	Net face area (total) - sq. ft.	21.40	21.40	
	Tube diameter - in.	3/8	3/8	
	Number of rows	3	3	
	Fins per inch	14	14	
	Drain connection - No. and size	(1) 1 in. FPT	(1) 1 in. FPT	
	Expansion device type	Balance port TXV, removable head		
<b><sup>2</sup> Indoor Blower and Drive Selection</b>	Nominal motor output	2 hp, 3 hp, 5 hp		
	Max. usable motor output (US)	2.3 hp, 3.45 hp, 5.75 hp		
	Motor - Drive kit number	<b>2 hp</b>		
		<b>Kit 1</b> 535-725 rpm		
		<b>Kit 2</b> 710-965 rpm		
<b>3 hp</b>				
<b>Kit 1</b> 535-725 rpm				
<b>Kit 2</b> 710-965 rpm				
<b>5 hp</b>				
<b>Kit 3</b> - 685-856 rpm				
<b>Kit 4</b> 850-1045 rpm				
<b>Kit 5</b> 945-1185 rpm				
Blower wheel nominal D x W - in.		(2) 15 x 15 in.	(2) 15 x 15 in.	
<b>Filters</b>	Type of filter	Fiberglass, disposable		
	Number and size - in.	(6) 24 x 24 x 2		
<b>Electrical characteristics</b>		208/230V or 460V - 60 hertz - 3 phase		

NOTE - Net capacity includes evaporator blower motor heat deduction. Gross capacity does not include evaporator blower motor heat deduction.

<sup>1</sup> AHRI Certified to AHRI Standard 340/360; 95°F outdoor air temperature and 80°F db/67°F wb entering evaporator air; minimum external duct static pressure.

<sup>2</sup> Using total air volume and system static pressure requirements determine from blower performance tables rpm and motor output required. Maximum usable output of motors furnished are shown. In Canada, nominal motor output is also maximum usable motor output. If motors of comparable output are used, be sure to keep within the service factor limitations outlined on the motor nameplate.

NOTE – Blower motor service factor = 1.0.

**SPECIFICATIONS**

**15 TON | 17.5 TON**

General Data		Nominal Tonnage	15 Ton	15 Ton	17.5 Ton	17.5 Ton	
		Model Number	LGM180U4M	LGM180U4V	LGM210U4M	LGM210U4V	
		Efficiency Type	Ultra-High	Ultra-High	Ultra-High	Ultra-High	
		Blower Type	SZVAV (Single Zone Variable Air Volume)	VAV (Variable Air Volume)	SZVAV (Single Zone Variable Air Volume)	VAV (Variable Air Volume)	
<b>Cooling Performance</b>	Gross Cooling Capacity - Btuh		176,000	176,000	206,000	206,000	
	<sup>1</sup> Net Cooling Capacity - Btuh		172,000	172,000	200,000	200,000	
	<sup>1</sup> AHRI Rated Air Flow - cfm		5250	5250	5400	5400	
	Total Unit Power - kW		14.3	14.3	16.7	16.7	
	<sup>1</sup> IEER (Btuh/Watt)		19.0	17.5	18.8	18.0	
	<sup>1</sup> EER (Btuh/Watt)		12.0	12.0	12.0	12.0	
<b>Refrigerant Charge</b>	Refrigerant Type		R-410A	R-410A	R-410A	R-410A	
Without Reheat	Circuit 1		19 lbs. 14 oz.	19 lbs. 14 oz.	10 lbs. 8 oz.	10 lbs. 8 oz.	
		Circuit 2	10 lbs. 15 oz.	10 lbs. 15 oz.	9 lbs. 10 oz.	9 lbs. 10 oz.	
		Circuit 3	10 lbs. 6 oz.	10 lbs. 6 oz.	9 lbs. 10 oz.	9 lbs. 10 oz.	
		Circuit 4	---	---	9 lbs. 12 oz.	9 lbs. 12 oz.	
	With Reheat	Circuit 1		22 lbs. 2 oz.	---	10 lbs. 8 oz.	---
		Circuit 2		12 lbs. 6 oz.	---	11 lbs. 0 oz.	---
		Circuit 3		10 lbs. 6 oz.	---	9 lbs. 10 oz.	---
		Circuit 4		---	---	9 lbs. 12 oz.	---
<b>Gas Heating Options Available</b>			See page 26				
<b>Compressor Type (number)</b>			Variable Capacity Scroll (1) Fixed Capacity Scroll (2)		Variable Capacity Scroll (1) Fixed Capacity Scroll (3)		
<b>Outdoor Coils (Fin/Tube)</b>	Net face area (total) - sq. ft.		55.2	55.2	55.2	55.2	
	Tube diameter - in.		3/8	3/8	3/8	3/8	
	Number of rows		2	2	2	2	
	Fins per inch		20	20	20	20	
<b>Outdoor Coil Fans</b>	Motor - (No.) horsepower		(4) 1/3 ECM	(4) 1/3 ECM	(6) 1/3 ECM	(6) 1/3 ECM	
	Motor rpm		280-1075	280-1075	640-950	640-950	
	Total Motor watts		150 -1350	150 -1350	290 -1250	290 -1250	
	Diameter - (No.) in.		(4) 24	(4) 24	(6) 24	(6) 24	
	Number of blades		3	3	3	3	
	Total Air volume - cfm		16,000	16,000	18,600	18,600	
<b>Indoor Coils</b>	Net face area (total) - sq. ft.		21.40	21.40	21.40	21.40	
	Tube diameter - in.		3/8	3/8	3/8	3/8	
	Number of rows		3	3	4	4	
	Fins per inch		14	14	14	14	
	Drain connection - No. and size		(1) 1 in. FPT	(1) 1 in. FPT	(1) 1 in. FPT	(1) 1 in. FPT	
Expansion device type			Balance port TXV, removable head				
<b><sup>2</sup> Indoor Blower and Drive Selection</b>	Nominal motor output		3 hp, 5 hp, 7.5 hp				
	Max. usable motor output (US)		3.45 hp, 5.75 hp, 8.62 hp				
	Motor - Drive kit number			<b>Kit 1</b> 535-725 rpm			
				<b>Kit 2</b> 710-965 rpm			
				<b>5 hp</b>			
				<b>Kit 3</b> 685-856 rpm			
				<b>Kit 4</b> 850-1045 rpm			
				<b>Kit 5</b> 945-1185 rpm			
				<b>7.5 hp</b>			
				<b>Kit 6</b> 850-1045 rpm			
		<b>Kit 7</b> 945-1185 rpm					
		<b>Kit 8</b> 1045-1285 rpm					
Blower wheel nominal D x W - in.		(2) 15 x 15					
<b>Filters</b>	Type of filter		Fiberglass, disposable				
	Number and size - in.		(6) 24 x 24 x 2				
<b>Electrical characteristics</b>			208/230V or 460V - 60 hertz - 3 phase				

NOTE - Net capacity includes evaporator blower motor heat deduction. Gross capacity does not include evaporator blower motor heat deduction.

<sup>1</sup> AHRI Certified to AHRI Standard 340/360; 95°F outdoor air temperature and 80°F db/67°F wb entering evaporator air; minimum external duct static pressure.

<sup>2</sup> Using total air volume and system static pressure requirements determine from blower performance tables rpm and motor output required. Maximum usable output of motors furnished are shown. In Canada, nominal motor output is also maximum usable motor output. If motors of comparable output are used, be sure to keep within the service factor limitations outlined on the motor nameplate.

NOTE – Blower motor service factor = 1.0.



**SPECIFICATIONS**

**20 TON | 25 TON**

General Data		Nominal Tonnage	20 Ton	20 Ton	25 Ton	25 Ton	
Model Number			LGM240U4M	LGM240U4V	LGM300U4M	LGM300U4V	
Efficiency Type			Ultra-High	Ultra-High	Ultra-High	Ultra-High	
Blower Type			SZVAV (Single Zone Variable Air Volume)	VAV (Variable Air Volume)	SZVAV (Single Zone Variable Air Volume)	VAV (Variable Air Volume)	
<b>Cooling Performance</b>	Gross Cooling Capacity - Btuh		235,000	235,000	277,000	277,000	
	<sup>1</sup> Net Cooling Capacity - Btuh		228,000	228,000	270,000	270,000	
	<sup>1</sup> AHRI Rated Air Flow - cfm		6000	6000	7400	7400	
	Total Unit Power - kW		19.0	19.0	19.0	19.0	
	<sup>1</sup> IEER (Btuh/Watt)		18.4	17.5	17.5	16.5	
	<sup>1</sup> EER (Btuh/Watt)		12.0	12.0	10.6	10.6	
<b>Refrigerant Charge</b>	Refrigerant Type		R-410A	R-410A	R-410A	R-410A	
	Without Reheat	Circuit 1	12 lbs. 2 oz.	12 lbs. 2 oz.	12 lbs. 8 oz.	12 lbs. 8 oz.	
		Circuit 2	12 lbs. 7 oz.	12 lbs. 7 oz.	11 lbs. 8 oz.	11 lbs. 8 oz.	
		Circuit 3	12 lbs. 0 oz.	12 lbs. 0 oz.	14 lbs. 8 oz.	14 lbs. 8 oz.	
		Circuit 4	12 lbs. 10 oz.	12 lbs. 10 oz.	11 lbs. 8 oz.	11 lbs. 8 oz.	
	With Reheat	Circuit 1	13 lbs. 4 oz.	---	17 lbs. 2 oz.	---	
		Circuit 2	13 lbs. 12 oz.	---	17 lbs. 5 oz.	---	
		Circuit 3	12 lbs. 0 oz.	---	14 lbs. 8 oz.	---	
		Circuit 4	12 lbs. 10 oz.	---	11 lbs. 8 oz.	---	
	<b>Gas Heating Options Available</b>			See page 26			
<b>Compressor Type (number)</b>			Variable Capacity Scroll (1) Fixed Capacity Scroll (3)				
<b>Outdoor Coils (Fin/Tube)</b>	Net face area (total) - sq. ft.		55.2	55.2	55.2	55.2	
	Tube diameter - in.		3/8	3/8	3/8	3/8	
	Number of rows		3	3	3	3	
	Fins per inch		20	20	20	20	
<b>Outdoor Coil Fans</b>	Motor - (No.) horsepower		(6) 1/3 ECM	(6) 1/3 ECM	(6) 1/3 ECM	(6) 1/3 ECM	
	Motor rpm		450 - 950	450 - 950	515 - 1000	515 - 1000	
	Total Motor watts		130 -1530	130 -1530	180 - 1730	180 - 1730	
	Diameter - (No.) in.		(6) 24	(6) 24	(6) 24	(6) 24	
	Number of blades		3	3	3	3	
	Total Air volume - cfm		18,000	18,000	18,300	18,300	
<b>Indoor Coils</b>	Net face area (total) - sq. ft.		21.40	21.40	21.40	21.40	
	Tube diameter - in.		3/8	3/8	3/8	3/8	
	Number of rows		4	4	4	4	
	Fins per inch		14	14	14	14	
	Drain connection - No. and size		(1) 1 in. FPT	(1) 1 in. FPT	(1) 1 in. FPT	(1) 1 in. FPT	
	Expansion device type		Balance port TXV, removable head				
<sup>2</sup> <b>Indoor Blower and Drive Selection</b>	Nominal motor output		5 hp, 7.5 hp, 10 hp				
	Max. usable motor output (US)		5.75 hp, 8.62 hp, 11.5 hp				
	Motor - Drive kit number		<b>5 hp</b> Kit 3 685-856 rpm Kit 4 850-1045 rpm Kit 5 945-1185 rpm <b>7.5 hp</b> Kit 6 850-1045 rpm Kit 7 945-1185 rpm Kit 8 1045-1285 rpm <b>10 hp</b> Kit 7 945-1185 rpm Kit 10 1045-1285 rpm Kit 11 1135-1365 rpm				
	Blower wheel nominal D x W - in.		(2) 15 x 15				
	<b>Filters</b>	Type of filter		Fiberglass, disposable			
		Number and size - in.		(6) 24 x 24 x 2			
	<b>Electrical characteristics</b>			208/230V or 460V - 60 hertz - 3 phase			

NOTE - Net capacity includes evaporator blower motor heat deduction. Gross capacity does not include evaporator blower motor heat deduction.

<sup>1</sup> AHRI Certified to AHRI Standard 340/360; 95°F outdoor air temperature and 80°F db/67°F wb entering evaporator air; minimum external duct static pressure.

<sup>2</sup> Using total air volume and system static pressure requirements determine from blower performance tables rpm and motor output required. Maximum usable output of motors furnished are shown. In Canada, nominal motor output is also maximum usable motor output. If motors of comparable output are used, be sure to keep within the service factor limitations outlined on the motor nameplate.

NOTE - Blower motor service factor = 1.0.

## SPECIFICATIONS - GAS HEAT

Usage Data		Model Number	LGM156 LGM180 LGM210	LGM156 LGM180 LGM210 LGM240 LGM300	LGM180 LGM210 LGM240 LGM300	
		Heat Input Type	Low (L)	Standard (S)	Medium (M)	High (H)
		Number of Gas Heat Stages	1	2	2	2
<b>Gas Heating Performance (Two-Stage)</b>	Input - Btuh	First Stage	169,000	169,000	234,000	312,000
		Second Stage	N/A	260,000	360,000	480,000
	Output - Btuh	First Stage	135,000	---	---	---
		Second Stage	N/A	208,000	288,000	384,000
<sup>1</sup> <b>Gas Heating Performance (Four-Stage)</b>	Input - Btuh	First Stage	N/A	84,500	117,000	156,000
		Second Stage	N/A	169,000	234,000	312,000
		Third Stage	N/A	214,000	297,000	396,000
		Fourth Stage	N/A	260,000	360,000	480,000
	Output - Btuh	First Stage	135,000	---	---	---
		Second Stage	N/A	---	---	---
		Third Stage	N/A	---	---	---
		Fourth Stage	N/A	208,000	288,000	384,000
Temperature Rise Range - °F			15 - 45	15 - 45	30 - 60	40 - 70
Thermal Efficiency			80.0%	80.0%	80.0%	80.0%
Gas Supply Connections			1 in. npt	1 in. npt	1 in. npt	1 in. npt
Recommended Gas Supply Pressure - in. w.g.	Natural		7	7	7	7
	LPG/Propane		11	11	11	11

<sup>1</sup> Four-stage gas heating is enabled when room sensor, Discharge Air Control, or fresh air tempering mode is selected. (Available when using the CS8500 thermostat or when connected to Building Automation Systems using BACnet, LonTalk, or S-Bus protocols)

## HIGH ALTITUDE DERATE

Units may be installed at altitudes up to 2000 feet above sea level without any modification.

At altitudes above 2000 feet, units must be derated to match gas manifold pressures shown in table below.

At altitudes above 4500 feet unit must be derated 2% for each 1000 feet above sea level.

NOTE – This is the only permissible derate for these units.

### TWO-STAGE

Gas Heat Type (Two-Stage)	Altitude - ft.	Gas Manifold Pressure - in. w.g.		Input Rate Natural Gas or LPG/Propane - Btuh	
		Natural Gas	LPG/Propane Gas	First Stage	Second Stage
Low (L)		No adjustment required			
Standard (S)	2001 - 4500	3.4	9.6	169,000	249,000
Medium (M)	2001 - 4500	3.4	9.6	234,000	345,000
High (H)	2001 - 4500	3.4	9.6	312,000	460,000

### FOUR-STAGE

<sup>1</sup> Gas Heat Type (Four-Stage)	Altitude - ft.	Gas Manifold Pressure - in. w.g.		Input Rate Natural Gas or LPG/Propane - Btuh			
		Natural Gas	LPG/Propane Gas	First Stage	Second Stage	Third Stage	Fourth Stage
Low (L)		No adjustment required					
Standard (S)	2001 - 4500	3.4	9.6	84,000	169,000	209,000	249,000
Medium (M)	2001 - 4500	3.4	9.6	117,000	234,000	289,000	345,000
High (H)	2001 - 4500	3.4	9.6	156,000	312,000	386,000	460,000

<sup>1</sup> Four-Stage Gas Heating is field configured.







**COOLING RATINGS**

NOTE - For Temperatures and Capacities not shown in tables, see bulletin - Cooling Unit Rating Table Correction Factor Data in Miscellaneous Engineering Data section.

**20 TON - LGM240U4M/V (ONE COMPRESSOR OPERATING)**

Table with 19 columns: Entering Wet Bulb Temperature, Total Air Volume, Outdoor Air Temperature (65°F, 75°F, 85°F, 95°F), Total Cool Cap., Comp. Motor Input, Sensible To Total Ratio (S/T) Dry Bulb. Rows include temperatures 63°F, 67°F, 71°F at various air volumes.

NOTE - Compressor operating at maximum capacity.

**20 TON - LGM240U4M/V (TWO COMPRESSORS OPERATING)**

Table with 19 columns: Entering Wet Bulb Temperature, Total Air Volume, Outdoor Air Temperature (85°F, 95°F, 105°F, 115°F), Total Cool Cap., Comp. Motor Input, Sensible To Total Ratio (S/T) Dry Bulb. Rows include temperatures 63°F, 67°F, 71°F at various air volumes.

NOTE - Compressors operating at maximum capacity.

**20 TON - LGM240U4M/V (THREE COMPRESSORS OPERATING)**

Table with 19 columns: Entering Wet Bulb Temperature, Total Air Volume, Outdoor Air Temperature (65°F, 75°F, 85°F, 95°F), Total Cool Cap., Comp. Motor Input, Sensible To Total Ratio (S/T) Dry Bulb. Rows include temperatures 63°F, 67°F, 71°F at various air volumes.

NOTE - Compressors operating at maximum capacity.

**20 TON - LGM240U4M/V (FOUR COMPRESSORS OPERATING)**

Table with 19 columns: Entering Wet Bulb Temperature, Total Air Volume, Outdoor Air Temperature (85°F, 95°F, 105°F, 115°F), Total Cool Cap., Comp. Motor Input, Sensible To Total Ratio (S/T) Dry Bulb. Rows include temperatures 63°F, 67°F, 71°F at various air volumes.

NOTE - Compressors operating at maximum capacity.









## BLOWER DATA

### FACTORY INSTALLED BELT DRIVE KIT SPECIFICATIONS

Motor Efficiency	Nominal hp	Maximum hp	Drive Kit Number	RPM Range
Standard	2	2.30	1	535 - 725
Standard	2	2.30	2	710 - 965
Standard	3	3.45	1	535 - 725
Standard	3	3.45	2	710 - 965
Standard	5	5.75	3	685 - 856
Standard	5	5.75	4	850 - 1045
Standard	5	5.75	5	945 - 1185
Standard	7.5	8.63	6	850 - 1045
Standard	7.5	8.63	7	945 - 1185
Standard	7.5	8.63	8	1045 - 1285
Standard	10	11.50	7	945 - 1185
Standard	10	11.50	10	1045 - 1285
Standard	10	11.50	11	1135 - 1365

NOTE - Using total air volume and system static pressure requirements determine from blower performance tables rpm and motor output required. Maximum usable output of motors furnished are shown. In Canada, nominal motor output is also maximum usable motor output. If motors of comparable output are used, be sure to keep within the service factor limitations outlined on the motor nameplate.

NOTE - Blower motor service factor = 1.0.

### FACTORY INSTALLED OPTIONS/FIELD INSTALLED ACCESSORY AIR RESISTANCE

Air Volume cfm	Wet Indoor Coil		Humiditrol™+ Reheat Coil	Gas Heat Exchanger			Economizer	Filters			Horizontal Roof Curb	
	156, 180	210, 240, 300		Low/ Standard Heat	Medium Heat	High Heat		MERV 8	MERV 13	MERV 16	156 thru 240	300
	in. w.g.	in. w.g.	in. w.g.	in. w.g.	in. w.g.	in. w.g.	in. w.g.				in. w.g.	in. w.g.
2750	.01	.02	.01	.02	.04	.05	---	.01	.03	0.06	.03	-
3000	.01	.02	.01	.03	.04	.05	---	.01	.03	0.06	.04	-
3250	.01	.03	.01	.03	.05	.06	---	.01	.04	0.07	.04	.01
3500	.01	.03	.02	.03	.05	.06	---	.01	.04	0.08	.05	.01
3750	.01	.03	.02	.04	.06	.07	---	.01	.04	0.08	.05	.01
4000	.02	.04	.02	.04	.06	.07	---	.01	.04	0.09	.06	.02
4250	.02	.04	.02	.04	.06	.08	---	.01	.05	0.10	.07	.02
4500	.02	.05	.02	.05	.07	.09	---	.01	.05	0.10	.07	.02
4750	.02	.05	.02	.05	.08	.10	---	.02	.05	0.11	.08	.03
5000	.02	.05	.02	.05	.09	.11	---	.02	.06	0.12	.08	.03
5250	.02	.06	.03	.06	.10	.12	---	.02	.06	0.12	.09	.04
5500	.02	.07	.03	.06	.10	.13	---	.02	.06	0.13	.10	.04
5750	.03	.07	.03	.06	.11	.14	---	.02	.07	0.14	.11	.05
6000	.03	.08	.03	.07	.12	.15	---	.03	.07	0.14	.11	.06
6250	.03	.08	.03	.07	.12	.16	.01	.03	.07	0.15	.12	.07
6500	.03	.09	.04	.08	.13	.17	.02	.03	.08	0.16	.13	.08
6750	.04	.10	.04	.08	.14	.18	.03	.03	.08	0.17	.14	.08
7000	.04	.10	.04	.09	.15	.19	.04	.04	.08	0.17	.15	.09
7250	.04	.11	.04	.09	.16	.20	.05	.04	.09	0.18	.16	.10
7500	.05	.12	.05	.10	.17	.21	.06	.04	.09	0.19	.17	.11
8000	.05	.13	.05	.11	.19	.24	.09	.05	.10	0.21	.19	.13
8500	.06	.15	.05	.12	.20	.26	.11	.05	.10	0.22	.21	.15
9000	.07	.16	.06	.13	.23	.29	.14	.06	.11	0.24	.24	.17
9500	.08	.18	.07	.14	.25	.32	.16	.07	.12	0.25	.26	.19
10,000	.08	.20	.07	.16	.27	.35	.19	.07	.12	0.27	.29	.21
10,500	.09	.22	.08	.17	.30	.38	.22	.08	.13	0.29	.31	.24
11,000	.11	.24	.08	.18	.31	.40	.25	.09	.14	0.30	.34	.27

## BLOWER DATA

### POWER EXHAUST FAN PERFORMANCE

Return Air System Static Pressure	Air Volume Exhausted
in. w.g.	cfm
0.00	8630
0.05	8210
0.10	7725
0.15	7110
0.20	6470
0.25	5790
0.30	5060
0.35	4300
0.40	3510
0.45	2690
0.50	1840

### CEILING DIFFUSER AIR RESISTANCE - in. w.g.

Air Volume cfm	Step-Down Diffuser						Flush Diffuser	
	RTD11-185S			RTD11-275S			FD11-185S	FD11-275S
	2 Ends Open	1 Side/2 Ends Open	All Ends & Sides Open	2 Ends Open	1 Side/2 Ends Open	All Ends & Sides Open		
5000	0.51	0.44	0.39	---	---	---	0.27	---
5200	0.56	0.48	0.42	---	---	---	0.30	---
5400	0.61	0.52	0.45	---	---	---	0.33	---
5600	0.66	0.56	0.48	---	---	---	0.36	---
5800	0.71	0.59	0.51	---	---	---	0.39	---
6000	0.76	0.63	0.55	0.36	0.31	0.27	0.42	0.29
6200	0.80	0.68	0.59	---	---	---	0.46	---
6400	0.86	0.72	0.63	---	---	---	0.50	---
6500	---	---	---	0.42	0.36	0.31	---	0.34
6600	0.92	0.77	0.67	---	---	---	0.54	---
6800	0.99	0.83	0.72	---	---	---	0.58	---
7000	1.03	0.87	0.76	0.49	0.41	0.36	0.62	0.40
7200	1.09	0.92	0.80	---	---	---	0.66	---
7400	1.15	0.97	0.84	---	---	---	0.70	---
7500	---	---	---	0.51	0.46	0.41	---	0.45
7600	1.20	1.02	0.88	---	---	---	0.74	---
8000	---	---	---	0.59	0.49	0.43	---	0.50
8500	---	---	---	0.69	0.58	0.50	---	0.57
9000	---	---	---	0.79	0.67	0.58	---	0.66
9500	---	---	---	0.89	0.75	0.65	---	0.74
10,000	---	---	---	1.00	0.84	0.73	---	0.81
10,500	---	---	---	1.10	0.92	0.80	---	0.89
11,000	---	---	---	1.21	1.01	0.88	---	0.96

### CEILING DIFFUSER AIR THROW DATA - ft.

Model No.	Air Volume cfm	<sup>1</sup> Effective Throw Range - ft.		Model No.	Air Volume cfm	<sup>1</sup> Effective Throw Range - ft.	
		RTD11-185S Step-Down	FD11-185S Flush			RTD11-275S Step-Down	FD11-275S Flush
156 180	5600	39 - 49	28 - 37	210 240 300	7200	33 - 38	26 - 35
	5800	42 - 51	29 - 38		7400	35 - 40	28 - 37
	6000	44 - 54	40 - 50		7600	36 - 41	29 - 38
	6200	45 - 55	42 - 51		7800	38 - 43	40 - 50
	6400	46 - 55	43 - 52		8000	39 - 44	42 - 51
	6600	47 - 56	45 - 56		8200	41 - 46	43 - 52
					8400	43 - 49	44 - 54
					8600	44 - 50	46 - 57
					8800	47 - 55	48 - 59

<sup>1</sup> Throw is the horizontal or vertical distance an airstream travels on leaving the outlet or diffuser before the maximum velocity is reduced to 50 ft. per minute. Four sides open.

**ELECTRICAL DATA**
**13 TON**

Model No.		LGM156U4					
<sup>1</sup> Voltage - 60Hz		208/230V-3ph			460V-3ph		
Compressor 1	Rated Load Amps	13.3			5.9		
	Locked Rotor Amps	21			11		
Compressor 2	Rated Load Amps	14.5			6.3		
	Locked Rotor Amps	98			55		
Compressor 3	Rated Load Amps	14.5			6.3		
	Locked Rotor Amps	98			55		
Outdoor Fan Motors (4)	Full Load Amps (total)	2.8 (11.2)			1.4 (5.6)		
Power Exhaust (2) 0.33 HP	Full Load Amps (total)	2.4 (4.8)			1.3 (2.6)		
Service Outlet 115V GFI (amps)		15			15		
Indoor Blower Motor	Horsepower	2	3	5	2	3	5
	Full Load Amps	7.5	10.6	16.7	3.4	4.8	7.6
<sup>2</sup> Maximum Overcurrent Protection (MOCP)	Unit Only	70	80	90	35	35	40
	With (2) 0.33 HP Power Exhaust	80	80	90	35	35	40
<sup>3</sup> Minimum Circuit Ampacity (MCA)	Unit Only	65	68	75	30	31	34
	With (2) 0.33 HP Power Exhaust	70	73	80	32	34	37

**ELECTRICAL DATA**
**15 TON**

Model No.		LGM180U4					
<sup>1</sup> Voltage - 60Hz		208/230V-3ph			460V-3ph		
Compressor 1	Rated Load Amps	15.7			6.8		
	Locked Rotor Amps	21			11		
Compressor 2	Rated Load Amps	16			7.8		
	Locked Rotor Amps	110			52		
Compressor 3	Rated Load Amps	16			7.8		
	Locked Rotor Amps	110			52		
Outdoor Fan Motors (4)	Full Load Amps (total)	2.8 (11.2)			1.4 (5.6)		
Power Exhaust (2) 0.33 HP	Full Load Amps (total)	2.4 (4.8)			1.3 (2.6)		
Service Outlet 115V GFI (amps)		15			15		
Indoor Blower Motor	Horsepower	3	5	7.5	3	5	7.5
	Full Load Amps	10.6	16.7	24.2	4.8	7.6	11
<sup>2</sup> Maximum Overcurrent Protection (MOCP)	Unit Only	80	90	110	40	45	50
	With (2) 0.33 HP Power Exhaust	90	100	110	45	45	50
<sup>3</sup> Minimum Circuit Ampacity (MCA)	Unit Only	74	80	90	35	38	42
	With (2) 0.33 HP Power Exhaust	79	85	94	38	41	45

NOTE - All units have a minimum Short Circuit Current Rating (SCCR) of 5000 amps.

<sup>1</sup> Extremes of operating range are plus and minus 10% of line voltage.

<sup>2</sup> HACR type breaker or fuse.

<sup>3</sup> Refer to National or Canadian Electrical Code manual to determine wire, fuse and disconnect size requirements.

**ELECTRICAL DATA**

**17.5 TON**

Model No.		LGM210U4					
<sup>1</sup> Voltage - 60Hz		208/230V-3ph			460V-3ph		
Compressor 1	Rated Load Amps	13.3			5.9		
	Locked Rotor Amps	21			11		
Compressor 2	Rated Load Amps	14.5			6.3		
	Locked Rotor Amps	98			55		
Compressor 3	Rated Load Amps	14.5			6.3		
	Locked Rotor Amps	98			55		
Compressor 4	Rated Load Amps	14.5			6.3		
	Locked Rotor Amps	98			55		
Outdoor Fan Motors (6)	Full Load Amps (total)	2.8 (16.8)			1.8 (8.4)		
Power Exhaust (2) 0.33 HP	Full Load Amps (total)	2.4 (4.8)			1.3 (2.6)		
Service Outlet 115V GFI (amps)		15					
Indoor Blower Motor	Horsepower	3	5	7.5	3	5	7.5
	Full Load Amps	10.6	16.7	24.2	4.8	7.6	11
<sup>2</sup> Maximum Overcurrent Protection (MOCP)	Unit Only	100	110	125	45	50	50
	With (2) 0.33 HP Power Exhaust	100	110	125	45	50	60
<sup>3</sup> Minimum Circuit Ampacity (MCA)	Unit Only	88	95	104	40	43	47
	With (2) 0.33 HP Power Exhaust	93	100	109	43	46	50

**ELECTRICAL DATA**

**20 TON**

Model No.		LGM240U4					
<sup>1</sup> Voltage - 60Hz		208/230V-3ph			460V-3ph		
Compressor 1	Rated Load Amps	16.8			7.8		
	Locked Rotor Amps	21			11		
Compressor 2	Rated Load Amps	13.2			6.3		
	Locked Rotor Amps	93			60		
Compressor 3	Rated Load Amps	13.2			6.3		
	Locked Rotor Amps	93			60		
Compressor 4	Rated Load Amps	13.2			6.3		
	Locked Rotor Amps	93			60		
Outdoor Fan Motors (6)	Full Load Amps (total)	2.8 (16.8)			1.4 (8.4)		
Power Exhaust (2) 0.33 HP	Full Load Amps (total)	2.4 (4.8)			1.3 (2.6)		
Service Outlet 115V GFI (amps)		15					
Indoor Blower Motor	Horsepower	5	7.5	10	5	7.5	10
	Full Load Amps	16.7	24.2	30.8	7.6	11	14
<sup>2</sup> Maximum Overcurrent Protection (MOCP)	Unit Only	110	125	125	50	50	60
	With (2) 0.33 HP Power Exhaust	110	125	125	50	60	60
<sup>3</sup> Minimum Circuit Ampacity (MCA)	Unit Only	95	104	112	45	49	53
	With (2) 0.33 HP Power Exhaust	99	109	117	48	52	56

NOTE - All units have a minimum Short Circuit Current Rating (SCCR) of 5000 amps.

<sup>1</sup> Extremes of operating range are plus and minus 10% of line voltage.

<sup>2</sup> HACR type breaker or fuse.

<sup>3</sup> Refer to National or Canadian Electrical Code manual to determine wire, fuse and disconnect size requirements.

**ELECTRICAL DATA**
**25 TON**

Model No.		LGM300U4					
<sup>1</sup> Voltage - 60Hz		208/230V-3ph			460V-3ph		
Compressor 1	Rated Load Amps	16.8			8.9		
	Locked Rotor Amps	21			11		
Compressor 2	Rated Load Amps	19.6			8.2		
	Locked Rotor Amps	136			66.1		
Compressor 3	Rated Load Amps	22.4			10.6		
	Locked Rotor Amps	149			75		
Compressor 4	Rated Load Amps	22.4			10.6		
	Locked Rotor Amps	149			75		
Outdoor Fan Motors (6)	Full Load Amps (total)	2.8 (16.8)			1.4 (8.4)		
Power Exhaust (2) 0.33 HP	Full Load Amps (total)	2.4 (4.8)			1.3 (2.6)		
Service Outlet 115V GFI (amps)		15			15		
Indoor Blower Motor	Horsepower	5	7.5	10	5	7.5	10
	Full Load Amps	16.7	24.2	30.8	7.6	11	14
<sup>2</sup> Maximum Overcurrent Protection (MOCP)	Unit Only	125	150	150	60	70	70
	With (2) 0.33 HP Power Exhaust	150	150	150	70	70	80
<sup>3</sup> Minimum Circuit Ampacity (MCA)	Unit Only	121	129	137	57	61	65
	With (2) 0.33 HP Power Exhaust	126	134	142	60	64	67

NOTE - All units have a minimum Short Circuit Current Rating (SCCR) of 5000 amps.

<sup>1</sup> Extremes of operating range are plus and minus 10% of line voltage.

<sup>2</sup> HACR type breaker or fuse.

<sup>3</sup> Refer to National or Canadian Electrical Code manual to determine wire, fuse and disconnect size requirements.

## ELECTRICAL ACCESSORIES

### DISCONNECTS

Voltage	208V	240V	208V	240V	208V	240V	460V	460V	460V
Model No.	<b>LGM156U4</b>								
Blower Motor HP	2		3		5		2	3	5
Unit Only	54W88	54W88	54W88	54W88	54W88	54W88	54W88	54W88	54W88
Unit w/ Power Exhaust	54W88	54W88	54W88	54W88	54W88	54W88	54W88	54W88	54W88
Model No.	<b>LGM180U4</b>								
Blower Motor HP	3		5		7.5		3	5	7.5
Unit Only	54W88	54W88	54W88	54W88	54W89	54W89	54W88	54W88	54W88
Unit w/ Power Exhaust	54W88	54W88	54W88	54W88	54W89	54W89	54W88	54W88	54W88
Model No.	<b>LGM210U4</b>								
Blower Motor HP	3		5		7.5		3	5	7.5
Unit Only	54W88	54W88	54W89	54W89	54W89	54W89	54W88	54W88	54W88
Unit w/ Power Exhaust	54W89	54W89	54W89	54W89	54W89	54W89	54W88	54W88	54W88
Model No.	<b>LGM240U4</b>								
Blower Motor HP	5		7.5		10		5	7.5	10
Unit Only	54W89	54W89	54W89	54W89	54W89	54W89	54W88	54W88	54W88
Unit w/ Power Exhaust	54W89	54W89	54W89	54W89	54W89	54W89	54W88	54W88	54W88
Model No.	<b>LGM300U4</b>								
Blower Motor HP	5		7.5		10		5	7.5	10
Unit Only	54W89	54W89	54W89	54W89	54W89	54W89	54W88	54W88	54W88
Unit w/ Power Exhaust	54W89	54W89	54W89	54W89	90W82	90W82	54W88	54W88	54W88

## INSTALLATION CLEARANCES

### Unit With Economizer

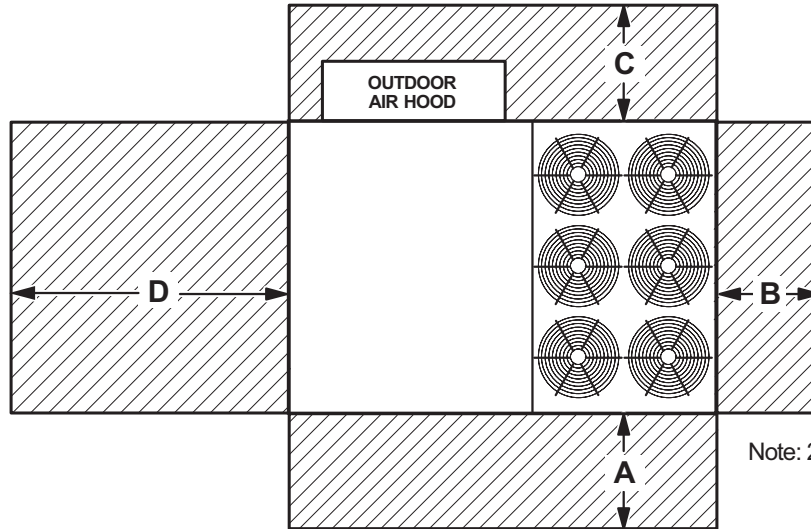

<sup>1</sup> Unit Clearance	A		B		C		D		Top Clearance
	in.	mm	in.	mm	in.	mm	in.	mm	
<b>Service Clearance</b>	60	1524	36	914	36	934	66	1676	Unobstructed
<b>Clearance to Combustibles</b>	36	914	1	25	1	25	1	25	
<b>Minimum Operation Clearance</b>	45	1143	36	914	36	914	41	1041	

NOTE - Entire perimeter of unit base requires support when elevated above the mounting surface.

<sup>1</sup> **Service Clearance** - Required for removal of serviceable parts.

**Clearance to Combustibles** - Required clearance to combustible material.

**Minimum Operation Clearance** - Required clearance for proper unit operation.

## OUTDOOR SOUND DATA

Unit Model Number	Octave Band Sound Power Levels dBA, re 10 <sup>-12</sup> Watts - Center Frequency - Hz							<sup>1</sup> Sound Rating Number (dBA)
	125	250	500	1000	2000	4000	8000	
156, 180	71	76	80	78	74	70	63	86
210, 240, 300	73	81	86	84	78	73	67	90

Note - The octave sound power data does not include tonal corrections.

<sup>1</sup> Sound Rating Number according to AHRI Standard 370-2001 (includes pure tone penalty).

Sound Rating Number is the overall A-Weighted Sound Power Level (L<sub>WA</sub>), dBA (100 Hz to 10,000 Hz).



WEIGHT DATA				UNIT	
Model Number	Net		Shipping		
	lbs.	kg	lbs.	kg	
156 Base Unit	2240	1016	2440	1107	
156 Max. Unit	2540	1152	2740	1243	
180 Base Unit	2250	1021	2450	1111	
180 Max. Unit	2550	1157	2750	1247	
210 Base Unit	2370	1075	2570	1166	
210 Max. Unit	2670	1211	2870	1302	
240 Base Unit	2520	1143	2720	1234	
240 Max. Unit	2820	1279	3020	1370	
300 Base Unit	2570	1166	2770	1256	
300 Max. Unit	2870	1302	3070	1393	

Max. Unit - The unit with ALL INTERNAL OPTIONS Installed. (Economizer, Standard Static Power Exhaust Fans, Controls, etc.). Does not include accessories external to unit.

WEIGHT DATA		OPTIONS / ACCESSORIES	
Description		Shipping Weight	
		lbs.	kg
<b>CEILING DIFFUSERS</b>			
<b>Step-Down</b>	RTD11-185S	168	76
	RTD11-275S	238	108
<b>Flush</b>	FD11-185S	168	76
	FD11-275S	238	108
<b>Transitions</b>	C1DIFF33C-1	80	36
	C1DIFF34C-1	75	34

#### ECONOMIZER / OUTDOOR AIR / EXHAUST

<b>Economizer</b>			
Economizer Dampers		102	46
Barometric Relief Dampers (downflow)		30	14
Barometric Relief Dampers (horizontal)		20	9
Outdoor Air Damper Hood (downflow)		65	29
<b>Outdoor Air Dampers</b>			
Outdoor Air Damper Section (downflow) - Automatic (including Hood)		18	39
Outdoor Air Damper Section (downflow) - Manual (including Hood)		10	22
<b>Power Exhaust</b>		62	28

#### GAS HEAT EXCHANGER (NET WEIGHT)

Medium Heat (adder over standard heat)		18	8
High Heat (adder over standard heat)		64	29

#### HUMIDITROL™+ HOT GAS REHEAT SYSTEM

Humiditrol+ Dehumidification Option (Net Weight)		50	23
--------------------------------------------------	--	----	----

#### ROOF CURBS

<b>Hybrid Roof Curbs, Downflow</b>			
8 in. height		75	34
14 in. height		105	48
18 in. height		125	57
24 in. height		155	70
<b>Adjustable Pitch Curb, Downflow</b>			
14 in. height		262	119
<b>Horizontal, Standard</b>			
26 in. height		470	213
37 in. height		505	229
30 in. height		575	261
41 in. height		610	277

#### PACKAGING

LTL Packaging (less than truck load)		310	141
--------------------------------------	--	-----	-----

# DIMENSIONS

# LGM156 | LGM180

## CORNER WEIGHTS

## CENTER OF GRAVITY

Model No.	AA		BB		CC		DD		EE		FF	
	lbs.	kg	lbs.	kg	lbs.	kg	lbs.	kg	in.	mm	in.	mm
LGM156 Base Unit	492	223	483	219	627	284	639	290	53-3/8	1356	39-5/8	1006
LGM156 Max. Unit	609	276	568	258	657	298	705	320	52	1321	42-1/4	1073
LGM180 Base Unit	493	224	482	219	630	286	645	292	53-1/4	1353	39-1/2	1003
LGM180 Max. Unit	611	277	568	257	660	299	711	323	51-7/8	1318	42-1/8	1070

Base Unit - The unit with NO INTERNAL OPTIONS.

Max. Unit - The unit with ALL INTERNAL OPTIONS Installed. (Economizer, Standard Static Power Exhaust Fans, Controls, etc.). Does not include accessories external to unit.

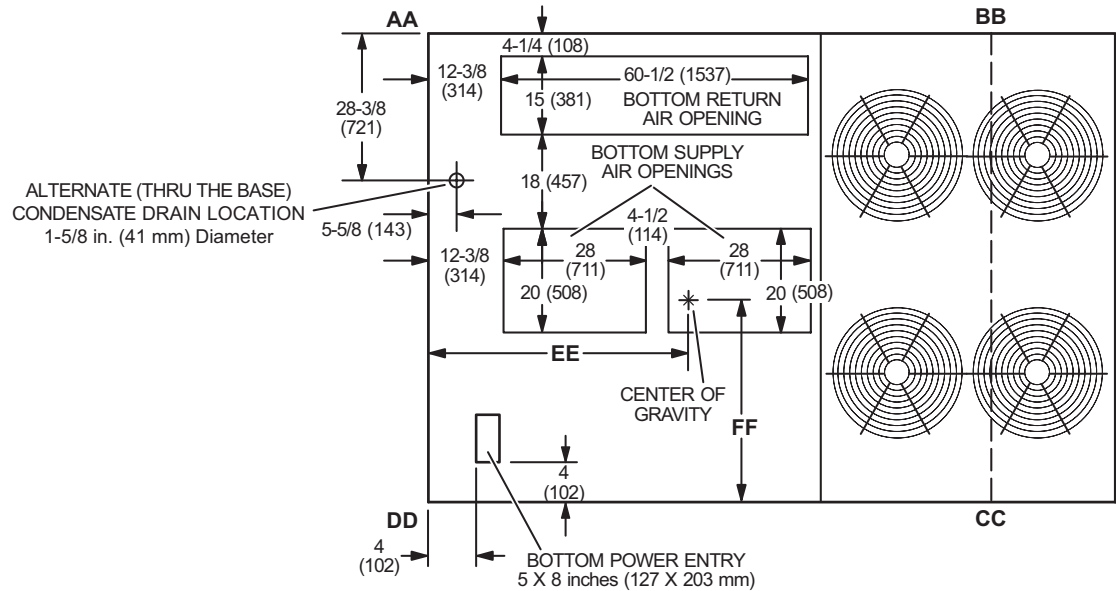

**TOP VIEW**

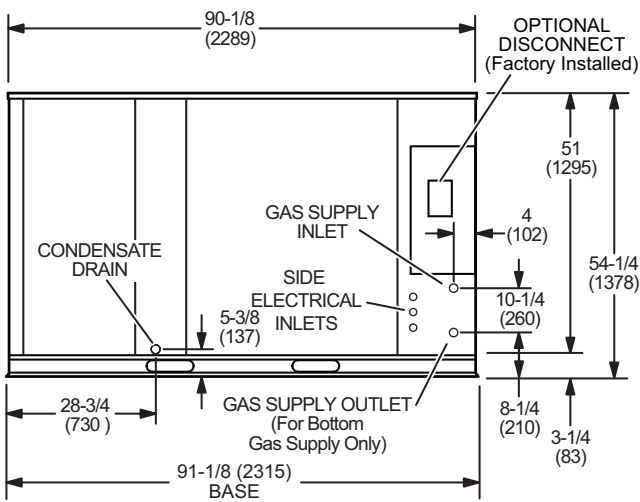

**END VIEW**

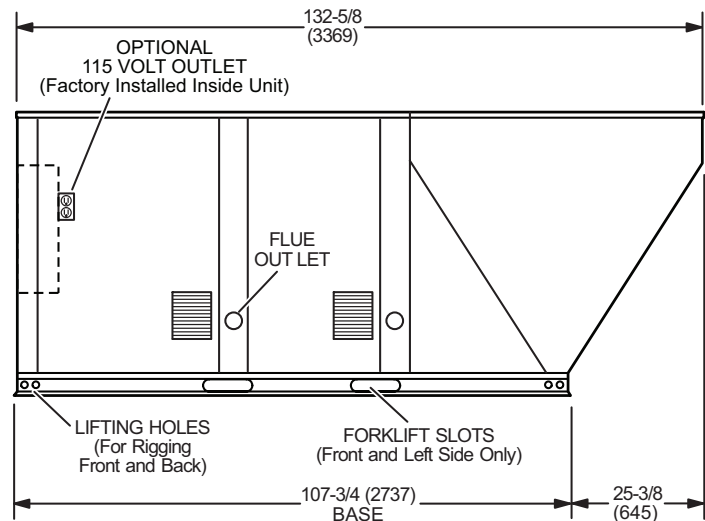

**SIDE VIEW**

**DIMENSIONS - UNIT**

**LGM210 | LGM240 | LGM300**

**CORNER WEIGHTS**

**CENTER OF GRAVITY**

Model No.	AA		BB		CC		DD		EE		FF	
	lbs.	kg	lbs.	kg	lbs.	kg	lbs.	kg	in.	mm	in.	mm
LGM210 Base Unit	486	221	502	228	702	318	680	308	54-3/4	1391	38	965
LGM210 Max. Unit	598	271	592	269	736	334	743	337	53-5/8	1362	40-5/8	1032
LGM240 Base Unit	509	231	546	247	758	344	707	321	55-3/4	1416	38-1/8	968
LGM240 Max. Unit	622	282	639	290	790	358	769	349	54-5/8	1387	40-3/4	1035
LGM300 Base Unit	513	233	548	248	779	353	730	331	55-5/8	1413	37-5/8	956
LGM300 Max. Unit	626	284	641	291	810	368	792	359	54-1/2	1384	40-1/4	1022

Base Unit - The unit with NO INTERNAL OPTIONS.

Max. Unit - The unit with ALL INTERNAL OPTIONS Installed. (Economizer, Standard Static Power Exhaust Fans, Controls, etc.). Does not include accessories external to unit.

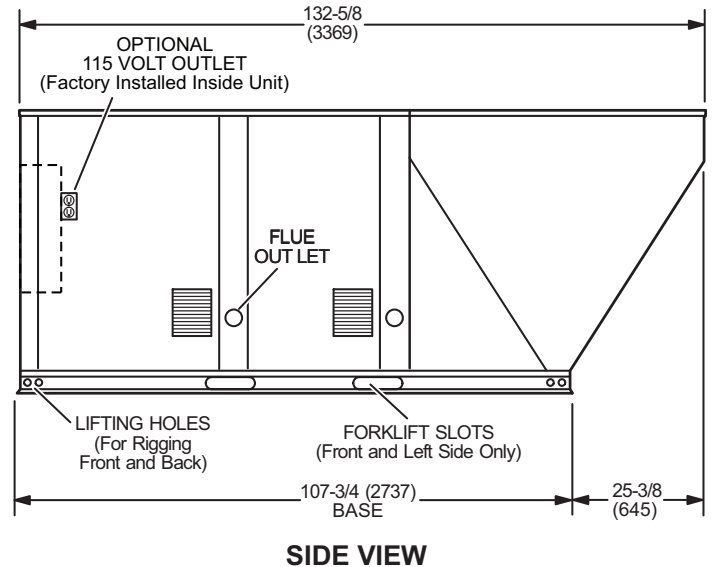
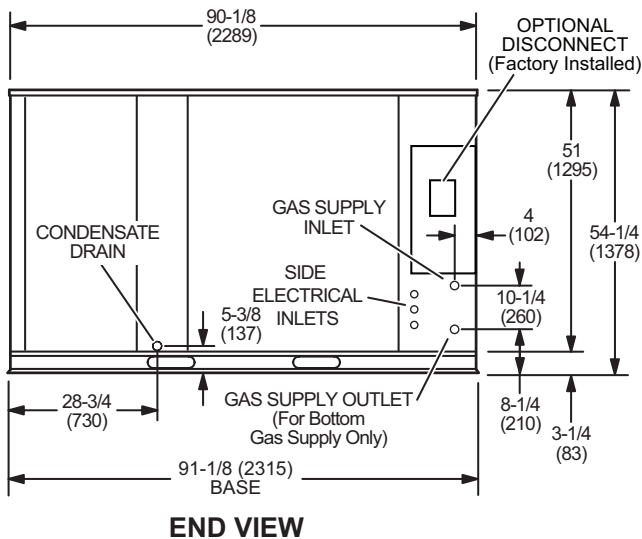
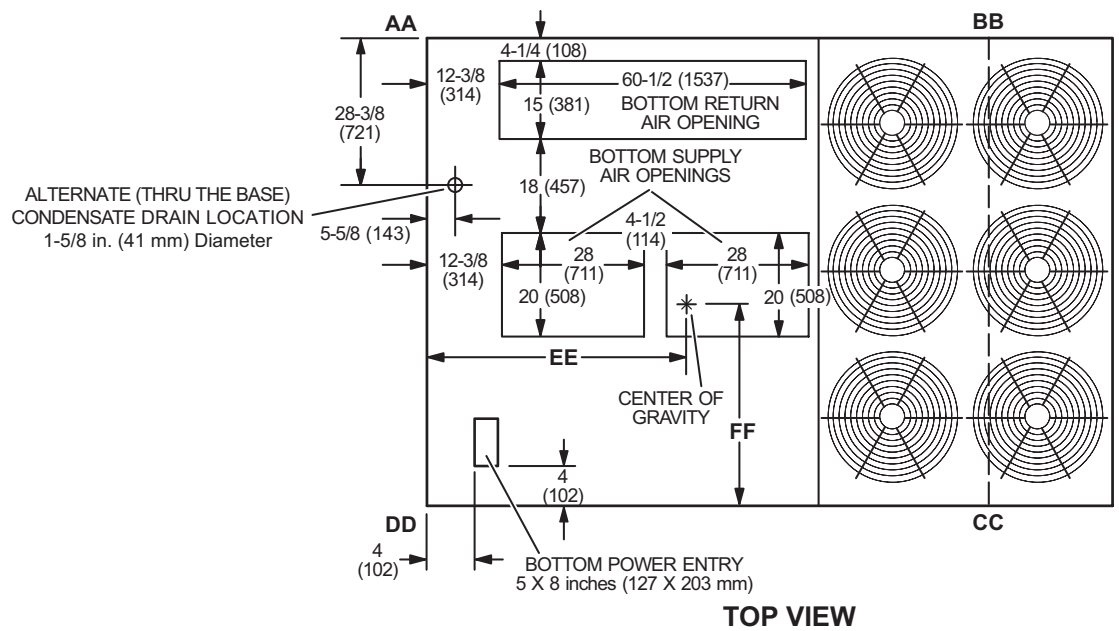

**OUTDOOR AIR HOOD DETAIL**

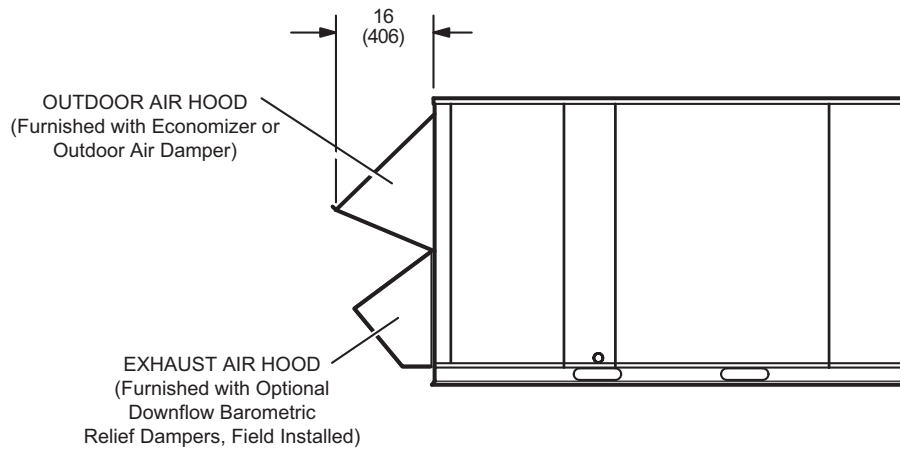

**OPTIONAL HORIZONTAL BAROMETRIC RELIEF DAMPERS WITH HOOD**

(Field installed in horizontal return air duct adjacent to unit)

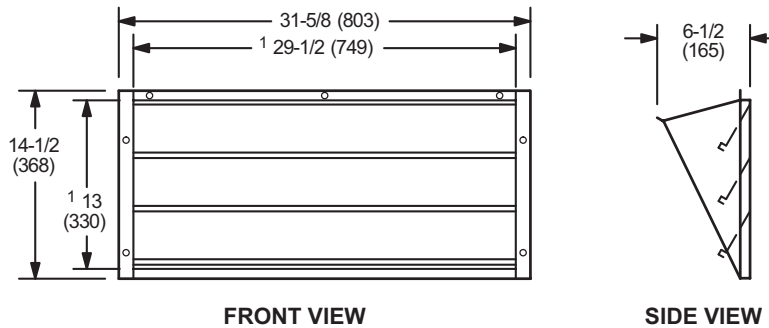

NOTE - Two furnished per order no.  
<sup>1</sup> NOTE - Opening size required in return air duct.

**HYBRID ROOF CURBS - DOUBLE DUCT OPENING**

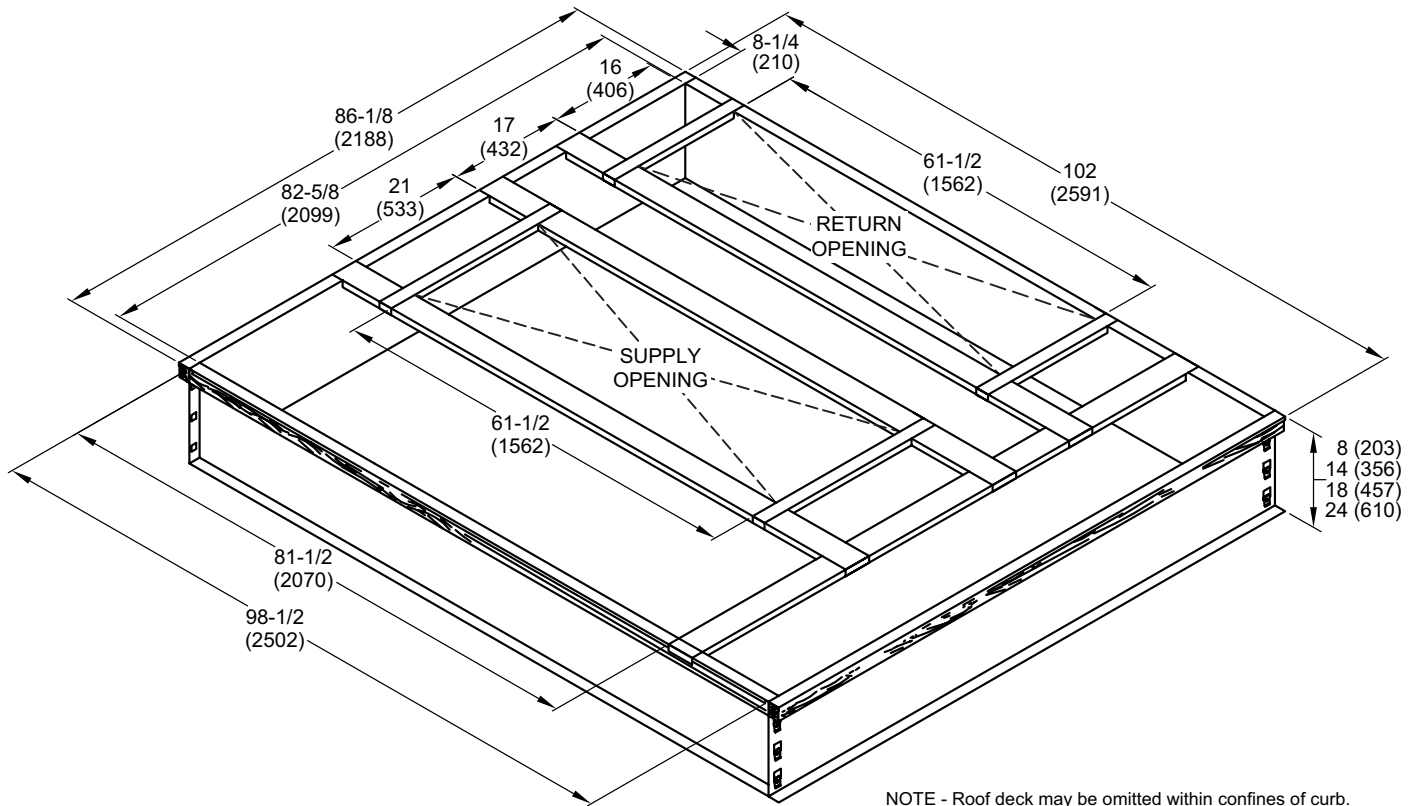

NOTE - Roof deck may be omitted within confines of curb.

**TYPICAL FLASHING DETAIL FOR ROOF CURB**

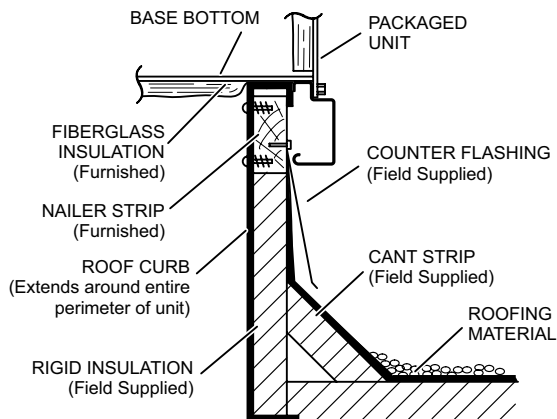

**DETAIL ROOF CURB**

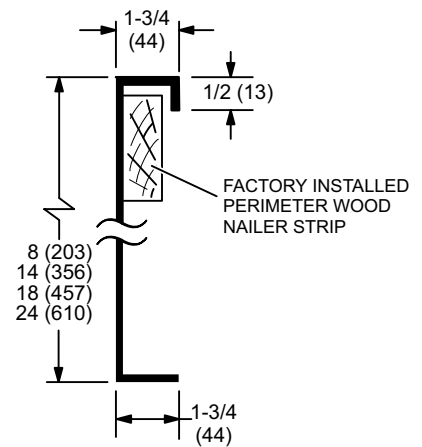

**ADJUSTABLE PITCH CURB - DOUBLE DUCT OPENING**

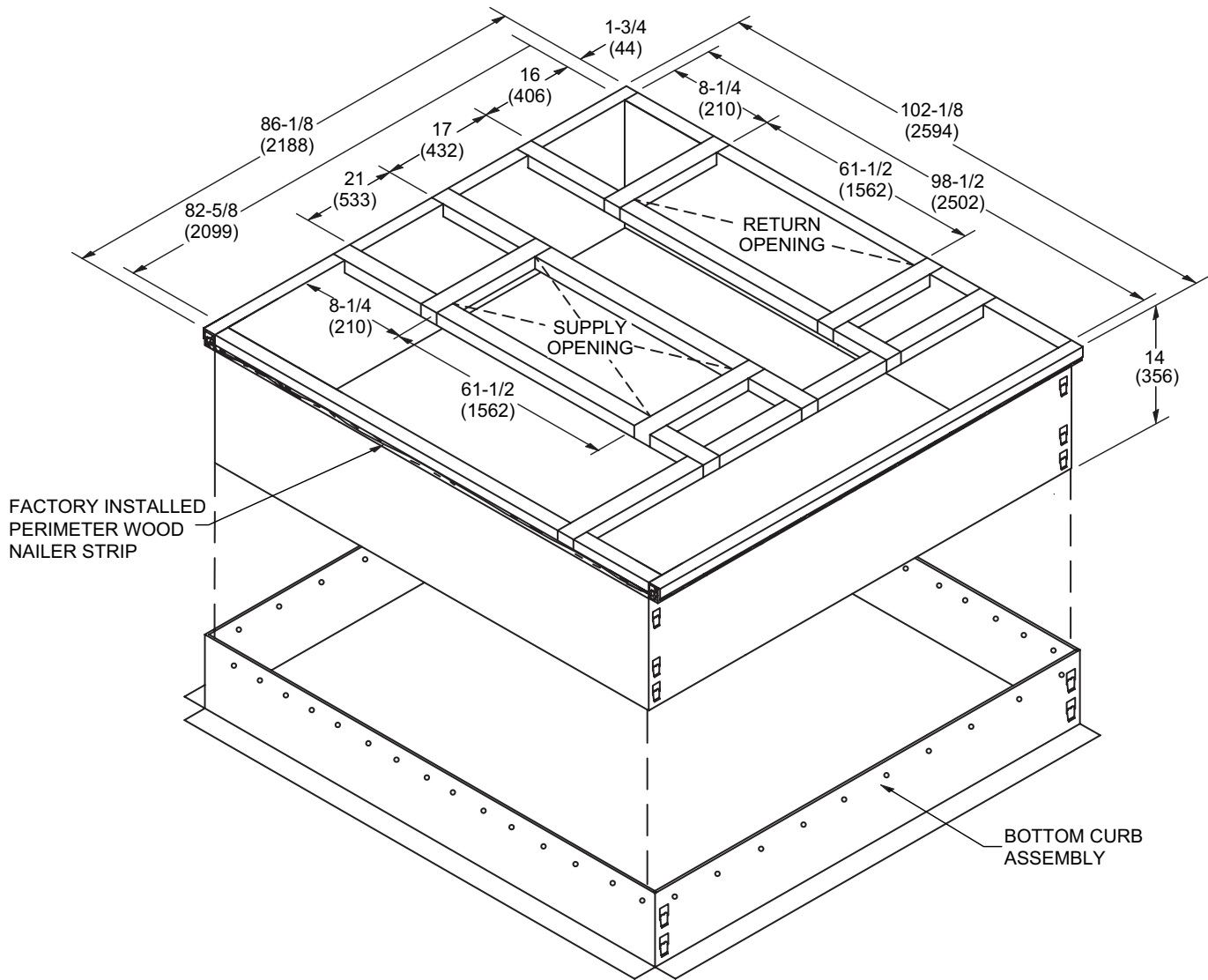

NOTE - Maximum slope pitch is 3/4 in. per 1 foot (19 mm per 305 mm) in any one direction.

**TYPICAL FLASHING DETAIL FOR ROOF CURB**

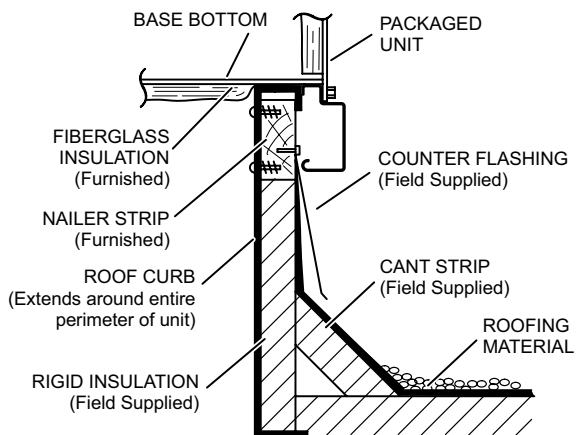

**DETAIL ROOF CURB**

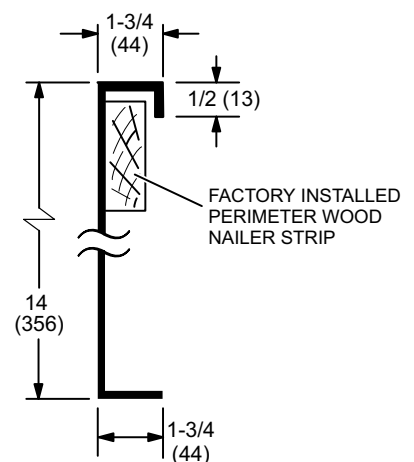

**ROOF CURBS WITH SUPPLY & RETURN AIR TRANSITIONS FOR CEILING DIFFUSERS**

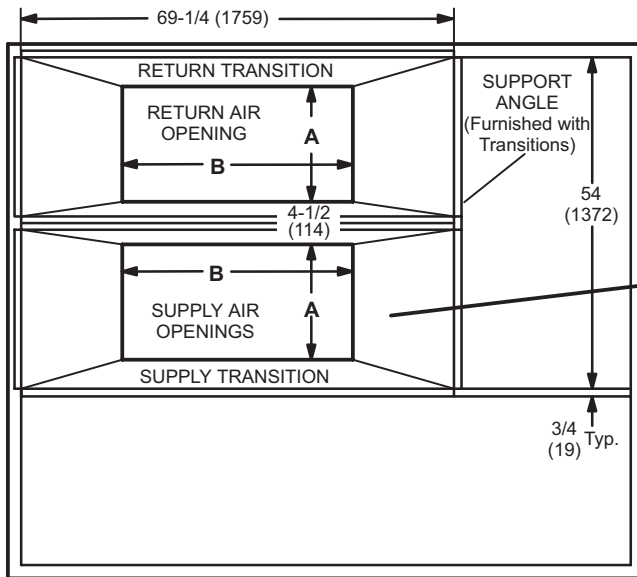

**TOP VIEW**

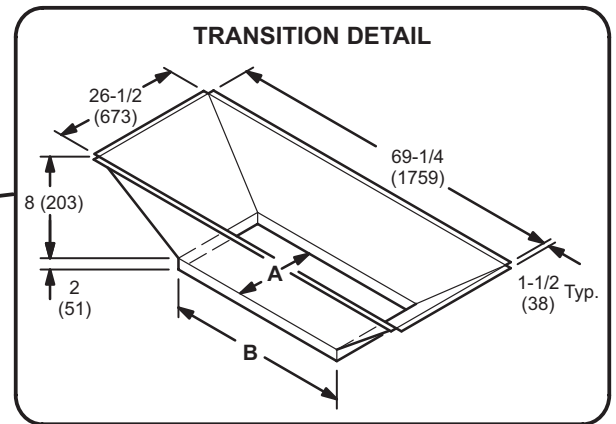

**TRANSITION OPENING SIZES**

Model Number	A		B	
	inch	mm	inch	mm
C1DIFF33C-1	18	457	36	914
C1DIFF34C-1	24	610	48	1219

**HORIZONTAL ROOF CURBS – Requires Optional Horizontal Return Air Panel Kit**

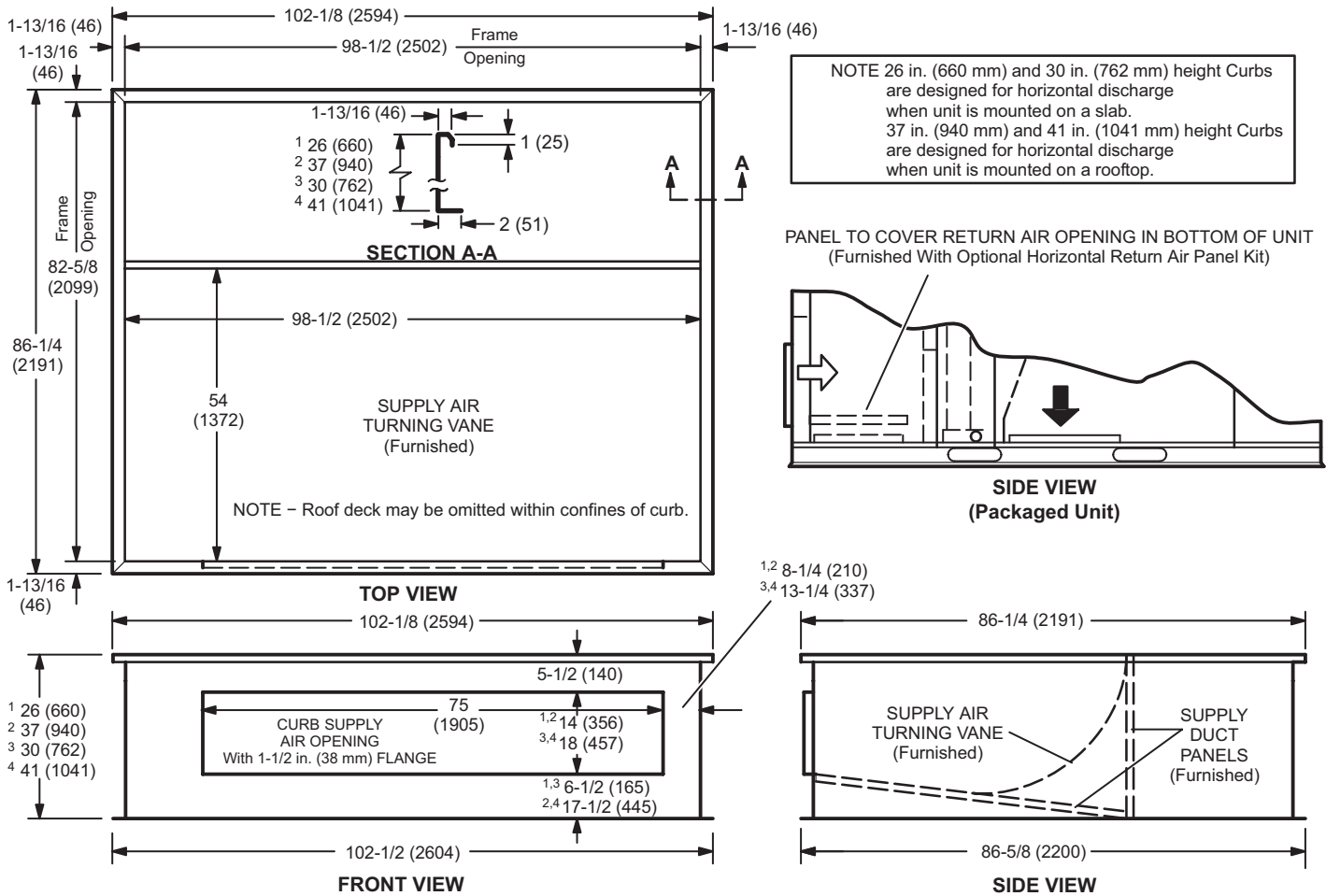

<sup>1</sup> Slab Applications   <sup>2</sup> Rooftop Applications   <sup>3</sup> Slab Applications (used with 300 only)   <sup>4</sup> Rooftop Applications (used with 300 only)

**HORIZONTAL SUPPLY AND RETURN AIR OPENINGS WITH HORIZONTAL ROOF CURB**

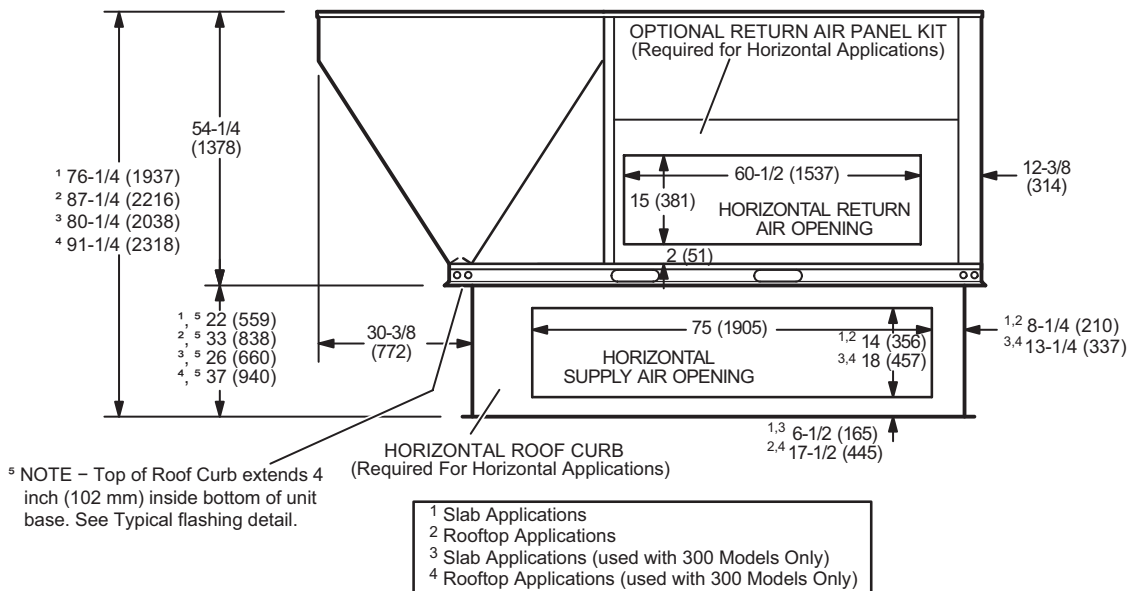



**COMBINATION CEILING SUPPLY AND RETURN DIFFUSERS**

**STEP-DOWN CEILING DIFFUSER**

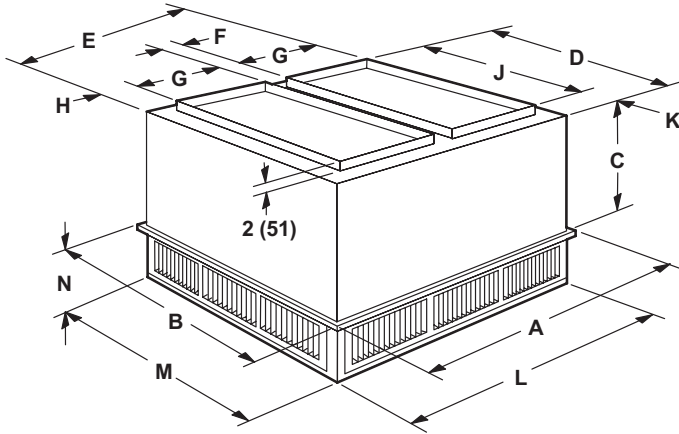

**FLUSH CEILING DIFFUSER**

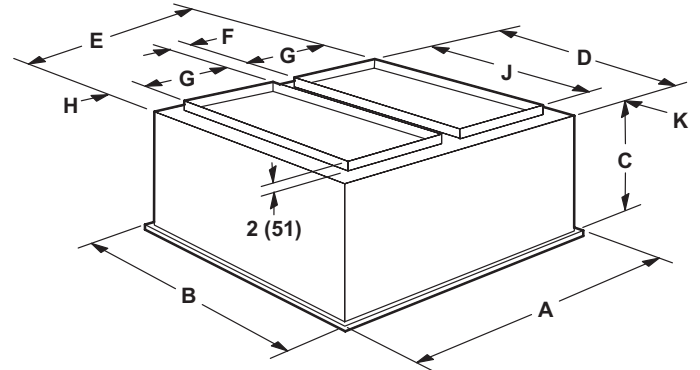

Model Number		RTD11-185S	RTD11-275S
<b>A</b>	in.	47-5/8	59-5/8
	mm	1210	1514
<b>B</b>	in.	47-5/8	59-5/8
	mm	1210	1514
<b>C</b>	in.	24-5/8	30-5/8
	mm	625	778
<b>D</b>	in.	45-1/2	57-1/2
	mm	1156	1461
<b>E</b>	in.	45-1/2	57-1/2
	mm	1156	1461
<b>F</b>	in.	4-1/2	4-1/2
	mm	114	114
<b>G</b>	in.	18	24
	mm	457	610
<b>H</b>	in.	2-1/2	2-1/2
	mm	64	64
<b>J</b>	in.	36	48
	mm	914	1219
<b>K</b>	in.	4-3/4	4-3/4
	mm	121	121
<b>L</b>	in.	45-1/2	57-1/2
	mm	1156	1461
<b>M</b>	in.	45-1/2	57-1/2
	mm	1156	1461
<b>N</b>	in.	10-1/8	11-1/8
	mm	257	283
<b>Duct Size</b>	in.	18 x 36	24 x 48
	mm	457 x 914	610 x 1219

Model Number		FD11-185S	FD11-275S
<b>A</b>	in.	47-5/8	59-5/8
	mm	1210	1514
<b>B</b>	in.	47-5/8	59-5/8
	mm	1210	1514
<b>C</b>	in.	29-1/4	35-1/4
	mm	743	895
<b>D</b>	in.	45	57
	mm	1143	1148
<b>E</b>	in.	45	57
	mm	1143	1448
<b>F</b>	in.	4-1/2	4-1/2
	mm	114	114
<b>G</b>	in.	18	24
	mm	457	610
<b>H</b>	in.	2-1/4	2-1/4
	mm	57	57
<b>J</b>	in.	36	48
	mm	914	1219
<b>K</b>	in.	4-1/2	4-1/2
	mm	114	114
<b>Duct Size</b>	in.	18 x 36	24 x 48
	mm	457 x 914	610 x 1219



Visit us at [www.Lennox.com](http://www.Lennox.com)

For the latest technical information, [www.LennoxCommercial.com](http://www.LennoxCommercial.com)

Contact us at 1-800-4-LENNOX

NOTE - Due to Lennox' ongoing commitment to quality, Specifications, Ratings and Dimensions subject to change without notice and without incurring liability. Improper installation, adjustment, alteration, service or maintenance can cause property damage or personal injury. Installation and service must be performed by a qualified installer and servicing agency.

©2021 Lennox Industries, Inc.