

Liebert® Air-Cooled, Fin/Tube Condensers™
User Manual—50/60 Hz



Table of Content

Important Safety Guidelines	1
1.0 Introduction	5
1.1 Product Description and Features	5
1.2 Agency Listed	5
1.3 Head Pressure Control Types	6
1.3.1 Fan Speed	6
1.3.2 Variable Frequency Drive	6
1.3.3 Liebert Lee-Temp™ Refrigerant Control	7
1.4 Sound Level Options	7
1.4.1 Standard Condenser	7
1.4.2 Liebert Quiet-Line Condenser	7
2.0 Site Preparation	9
2.1 Site Considerations	9
2.2 Dimensions and Weights	10
3.0 Inspection and Installation	17
3.1 Equipment Inspection	17
3.1.1 Packing Material	17
3.2 Handling Unit on the Skid	18
3.3 Unit Storage	19
3.4 Unpacking the Condenser—All Unit Sizes	19
3.5 Preparing 1- to 4-fan Condenser for Moving and Installation	21
3.6 Preparing 6- and 8-fan condensers for Moving and Installation	25
3.7 Mounting the Condenser	29
3.7.1 Standard Mounting Requirements	29

4.0 Piping	31
4.1 Piping Guidelines	32
4.2 Condenser Positioning guidelines	33
4.3 Field Piping Requirements	36
4.4 Piping Connections	38
4.5 Refrigerant Planning Values	44
4.5.1 Refrigerant Oil Addition Procedures	45
4.5.2 System Dehydration/Leak Test and Charging Procedures	45
5.0 Electrical Connections	47
5.1 Electrical Supply Preparation	47
5.1.1 Line Voltage Wiring	49
5.1.1.1 Line Voltage —VFD-Control Condensers Only	49
5.1.1.2 Disconnect EMC Filter for Delta-Connected Power	50
5.1.1.3 Surge Protection Device—VFD-control Condensers Only	51
5.1.2 Low Voltage Control Wiring	52
5.1.2.1 Low Voltage Monitoring Wiring—VFD Condensers Only	53
5.2 Electrical field connection descriptions	54
6.0 Checklist for Completed Installation	57
6.1 Moving and Placing Equipment	57
6.2 Electrical	57
6.3 Piping	57
6.4 Other	57
7.0 Operation	59
7.1 Startup Checklist	59
7.2 Startup	59
8.0 Troubleshooting	61
9.0 System Maintenance	63
9.1 General Procedures	63
9.2 Special Procedures	64
9.2.1 Condenser Cleaning	64
10.0 Preventive Maintenance Checklist	65

List of Figures

Figure 1-1: Liebert two-fan condenser	5
Figure 1-2: Product model nomenclature	6
Figure 2-1: Condenser planning dimensional data—1- and 2-fan units	12
Figure 2-2: Condenser planning dimensional data—3- and 4-fan units	13
Figure 2-3: Condenser planning dimensional data—6- and 8-fan units	14
Figure 2-4: Typical fin/tube condenser footprint—dimensions	15
Figure 3-1: Equipment recommended for handling a Liebert condenser	18
Figure 3-2: Forklift position with 1- to 8-fan condensers	19
Figure 3-3: Removing protective material	20
Figure 3-4: Attaching legs to 1-fan to 4-fan condensers	21
Figure 3-5: Securing slings to 1- to 4-fan condensers for lifting off skid	22
Figure 3-6: Rotate and set condenser on floor	23
Figure 3-7: Rigging to lift 1- to 4-fan condensers	24
Figure 3-8: Attach legs to higher side of 6- or 8-fan condenser	25
Figure 3-9: Use sling to lower side with legs attached	26
Figure 3-10: Move sling to side resting on skid and lift to remove skid/install legs	27
Figure 3-11: Rigging 6- and 8-fan condenser for lifting	28
Figure 4-1: Condenser positioning at the same level as indoor unit	33
Figure 4-2: Condenser positioning above the indoor unit	34
Figure 4-3: Condenser positioning below indoor unit	35
Figure 4-4: Typical system configuration—indoor unit and outdoor condenser and field piping	37
Figure 4-5: Single-circuit piping, VFD and Fan Speed Control, 1-4 fan condensers	38
Figure 4-6: Single-circuit piping, Liebert Lee-Temp™ and Liebert Quiet-Line™ 1-4 fan condensers	39
Figure 4-7: Dual-circuit piping, VFD and Fan Speed Control, 1-4 fan condensers	40
Figure 4-8: Dual-circuit piping, Liebert Lee-Temp™ and Liebert Quiet-Line™ 1-4 fan condensers	41
Figure 4-9: Dual-circuit piping, Fan Speed Control, 6- and 8-fan condensers	42
Figure 4-10: Dual-circuit piping, Liebert Lee-Temp and Liebert Quiet-Line 6- and 8-fan condensers	43
Figure 5-1: Wye-connected power diagram	50
Figure 5-2: Delta-connected power diagram	50
Figure 5-3: Disconnecting EMC filter for operation with Delta-connected power	51
Figure 5-4: Electrical field connections for Fan Speed Control Condensers	54
Figure 5-5: Electrical field connections for VFD control condensers	55
Figure 5-6: Electrical field connections for Liebert Lee-Temp control condensers	56

List of Tables

Table 2-1: Air-cooled condenser weights, dimensions and volume, approximate	10
Table 2-2: Liebert Lee-Temp™ receiver weights	11
Table 4-1: Indoor unit maximum distance from the remote condenser—Fin/Tube condenser with or without Liebert Lee-Temp	33
Table 4-2: R-22 and R-407C refrigerant required, approximate	44
Table 4-3: R-407C refrigerant required for DCSL616 condensers for Liebert XDC, approximate	44
Table 4-4: R-410A refrigerant required, approximate	44
Table 4-5: Interconnecting piping refrigerant charge	45
Table 5-1: 60Hz condenser data	48
Table 5-2: 60Hz condenser data, Liebert Quiet-Line (Liebert Lee-Temp controlled/fan-cycling)	48
Table 5-3: 50Hz condenser full load amp values	48
Table 5-4: Liebert Lee-Temp receiver electrical data, 50Hz and 60Hz.	49
Table 5-5: Minimum recommended control circuit wire size, AWG, 60Hz models	52
Table 5-6: Minimum recommended control circuit wire size, mm ² , 50 Hz models	52
Table 8-1: Troubleshooting	61

Important Safety Guidelines

SAVE THESE INSTRUCTIONS

This manual contains important safety instructions that should be followed during the installation and maintenance of the Liebert Fin/Tube Condenser. Read this manual thoroughly before attempting to install or operate this unit.

Only qualified personnel should move, install or service this equipment.

Adhere to all warnings, cautions and installation, operating and safety instructions on the unit and in this manual. Follow all operating and user instructions.



WARNING

Risk of improper handling, installation and service. Can cause property damage, injury or death.

Only properly trained and qualified personnel should install or perform repairs or maintenance on this unit. Read all installation, operation and safety alerts and instructions and wear appropriate protective headgear, safety glasses, gloves and clothing before installing, operating or servicing this unit.



WARNING

Arc flash and electric shock hazard. Open all local and remote electric power disconnect switches, verify with a voltmeter that power is Off and wear personal protective equipment per NFPA 70E before working within the electric control enclosure. Failure to comply can cause serious injury or death.

Customer must provide earth ground to unit, per NEC, CEC and local codes, as applicable.

Before proceeding with installation, read all instructions, verify that all the parts are included and check the nameplate to be sure the voltage matches available utility power.

The factory-supplied disconnect switch is inside the electric control enclosure. The line side of this switch contains live high-voltage.

The only way to ensure that there is NO voltage inside the unit is to install and open a remote disconnect switch. Refer to unit electrical schematic.

Follow all local codes.



WARNING

Risk of contact with high-speed, rotating fan blades. Can cause serious injury or death.

Fan blades can automatically start rotating without warning at any time during a cooling cycle or after power is restored after a power failure. Open all local and remote electric power supply disconnect switches, wait 10 minutes and verify with a voltmeter that power is Off before working within the unit cabinet, removing the fan guards or servicing the fan speed control, fan blades or fan motors.



WARNING

Risk of electrical fire and short circuit. Can cause property damage, injury or death.

Select and install the line side electrical supply wire and overcurrent protection device(s) according to the specifications on the unit nameplate(s), per the instructions in this manual and according to the applicable national, state and local code requirements. Use copper conductors only.

Verify that all electrical connections are tight. Unit-specific wiring diagrams are provided on each unit.



WARNING

Risk of electric shock. Can cause injury or death.

The optional, variable-frequency fan-speed control may contain a stored electrical charge. Open all local and remote electric power disconnect switches, verify with a voltmeter that power is Off and wait 10 minutes before working within the optional, variable-frequency fan-speed control electrical enclosures.



WARNING

Risk of heavy condenser falling or tipping over. Can cause property damage, serious injury or death.

Confirm that all components of the lifting system are rated for the weight of the condenser by an OSHA Certified rating organization before attempting to lift and/or move the condenser. See **Table 2-1** for the condenser weights.



CAUTION

Risk of contact with hot surfaces. Can cause injury.

Fan motors, transformers, piping and other components may become extremely hot during normal operation. Wear thermally insulated gloves and appropriate protective clothing and allow time for components to cool when working within the cabinet or electric control enclosure.



CAUTION

Risk of contact with sharp edges, splinters and exposed fasteners. Can cause personal injury.

Only properly trained and qualified personnel wearing appropriate safety headgear, gloves, shoes and glasses should attempt to move, lift, remove packaging from or prepare unit for installation.



CAUTION

Risk of explosive discharge of high-pressure gas. Can cause injury.

Relieve system pressure and verify that the indoor and outdoor units are Off before making piping connections/disconnections.

Do not exceed the design pressure rating that is marked on the nameplate.

Do not install a shutoff valve between the compressor and the field-installed pressure relief valve.

NOTICE

Risk of improper storage. Can cause unit damage.

Keep unit protected from contact damage.

NOTICE

Risk of improper forklift handling. Can cause unit damage.

Keep the forklift tines level and at a height that will fit under the skid.

NOTICE

Risk of improper refrigerant charging. Can cause equipment damage.

Refrigerant R-407C and R-410A are blended refrigerants and must be introduced and charged from the cylinder only as a liquid.

When adding liquid refrigerant to an operating system, it may be necessary to add the refrigerant through the compressor suction service valve. Care must be exercised to avoid damage to the compressor.

Emerson recommends connecting a sight glass between the charging hose and the compressor suction service valve. This will permit adjusting the cylinder hand valve so that liquid can leave the cylinder while allowing vapor to enter the compressor.

NOTICE

Risk of refrigerant overcharge. Can cause equipment damage.

Do not use the sight glass as an indicator when charging Liebert Fin/Tube Condenser condenser systems.

NOTICE

Risk of using damaging cleaning agents, including non-base paint solvents. Can cause equipment damage and damage to property and loss of refrigerant charge.

Using acid-based or sodium hydroxide-based cleaners can damage the Liebert Fin/Tube Condenser condenser coil and cause a loss of charge. This could cause equipment damage as well as damage to the surrounding structure.

Page intentionally left blank.

1.0 Introduction

1.1 Product Description and Features

The Liebert Fin/Tube Condenser is a low-profile, direct-drive propeller fan-type, air-cooled unit suitable for mounting outdoors. It provides for the heat rejection of either one or two separate refrigeration circuits, matching heat rejection capacity varying with the outdoor ambient temperatures and with each corresponding compressors heat rejection requirements. Constructed with an aluminum cabinet and a copper-tube aluminum fin coil, the unit is quiet and corrosion resistant. The condenser is quickly and easily installed, because all internal wiring is completed at the factory with only electrical connections to be made at the job site. All electrical connections and controls are enclosed in an integral weatherproof section of the condenser.

Figure 1-1 Liebert two-fan condenser



1.2 Agency Listed

Standard 60Hz units are CSA certified to the harmonized U.S. and Canadian product safety standard, CSA C22.2 No 236/UL 1995 for "Heating and Cooling Equipment" and are marked with the CSA c-us logo.



Figure 1-2 Product model nomenclature

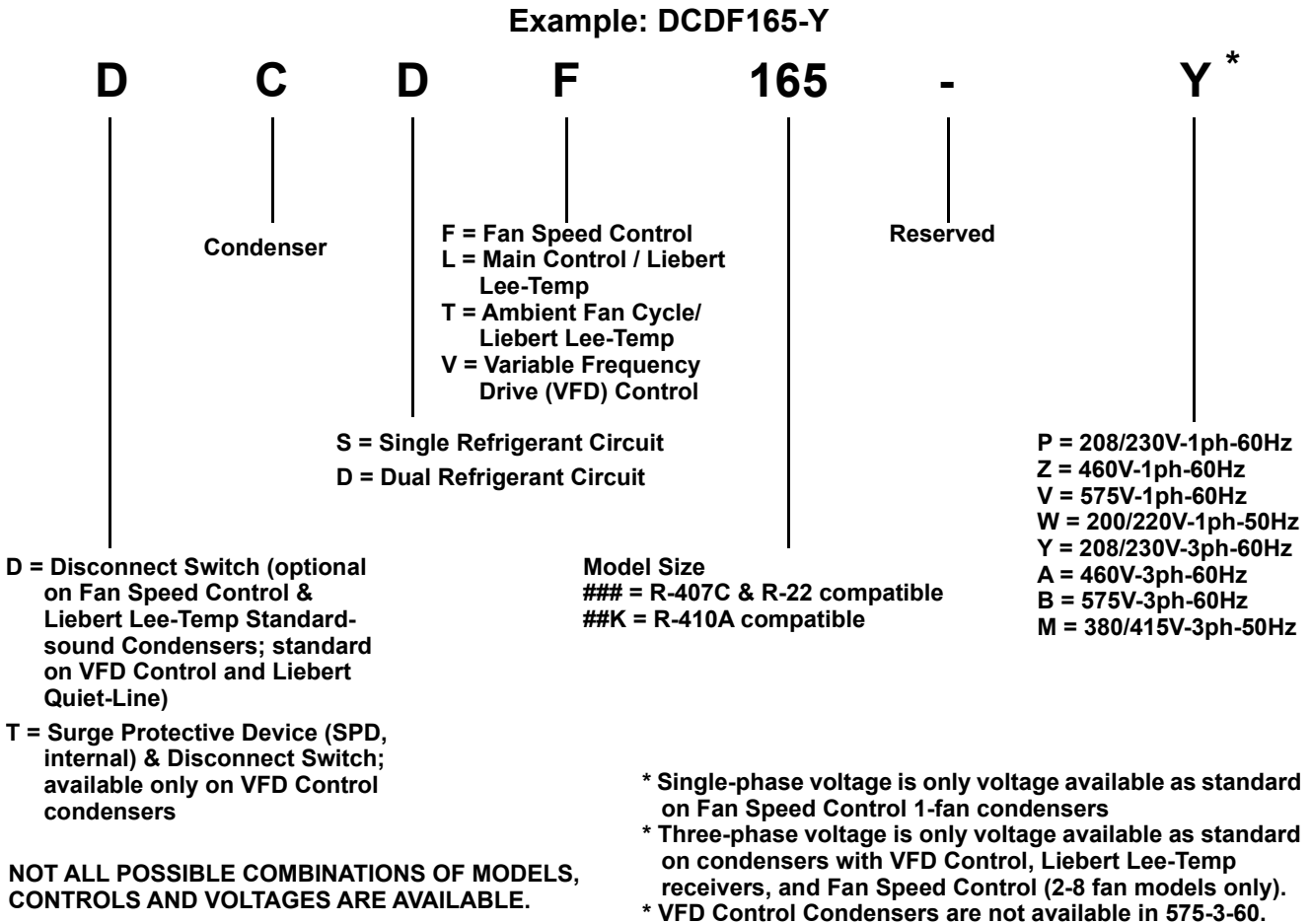

1.3 Head Pressure Control Types

1.3.1 Fan Speed

Fan speed control utilizes a wave-chopper control to vary the air volume over the condenser coil, based on refrigerant head pressure. The fan motor next to the electrical panel (two fans on 6-fan and 8-fan models) is a single-phase, permanent split capacitor motor with motor speed adjusted in response to refrigerant pressure. The balance of fans on multi-fan units cycle on ambient thermostats. The control system provides refrigerant head pressure control for outdoor ambients as low as -20°F (-28.9 °C).

1.3.2 Variable Frequency Drive

VFD Condenser control system utilizes a variable frequency drive, inverter duty fan motor operating from 0% to 100% motor RPM based on head pressure, sensed by refrigerant pressure transducers. VFD, ambient-temperature thermostat(s), motor overload protection and electrical control circuit are factory-wired in the integral control panel. VFD controls the fan adjacent to the connection end of the condenser and remains energized with active compressor operation. The balance of fans on multi-fan units cycle on ambient thermostats. This system provides refrigerant head pressure control for outdoor ambients as low as 0 F (-17.8 C) as standard and, with optional, low-ambient VFD heater kit, will start/operate as low as -20°F (-28.9°C).

1.3.3 Liebert Lee-Temp™ Refrigerant Control

The Liebert Lee-Temp head pressure control system is designed to maintain proper operating head pressures in outdoor temperatures down to -30°F (-34.4°C). The condensers utilize head pressure control valves, extra refrigerant and insulated refrigerant receivers with heater pads. It works by flooding the condenser coil with liquid refrigerant to a level that balances the system condensing requirements with the condenser coil surface available to reject the system heat. During the summer, the system requires the entire condenser coil surface for heat rejection and most of the refrigerant is stored in a receiver. In the winter, the same amount of heat can be rejected by only a fraction of the coil surface. As head pressure begins to fall, the control valve restricts the flow of liquid refrigerant exiting from the condenser. This extra liquid refrigerant reduces the effective condenser surface area available for heat transfer. The head pressure control valve also bypasses hot gas into the receiver to warm the liquid and maintain liquid pressure for proper operation of the expansion valve. Condenser fan controls are either fan cycling on ambient temperature or constant on. Liebert Lee-Temp control is required for Liebert Quiet-Line Condensers.

1.4 Sound Level Options

1.4.1 Standard Condenser

All Fan Speed and VFD Condensers are standard condensers with moderate operating sound levels. Liebert Lee-Temp condensers with standard-size coils matching Fan Speed and VFD coil sizes are standard sound level condensers.

1.4.2 Liebert Quiet-Line Condenser

Liebert Quiet-Line Condensers can help your facility meet the strictest noise codes and do so at less cost than traditional condensers with acoustical shielding. The Liebert Quiet-Line Condensers utilize the same reliable construction features of the standard condensers and have oversized coils and slower speed fan motors which yield the required heat rejection needed at significantly lower sound levels. Liebert Lee-Temp control is required for Liebert Quiet-Line Condensers.

Page intentionally left blank.

2.0 Site Preparation

2.1 Site Considerations

The condensers should be installed in a location offering maximum security and access for maintenance.

Avoid ground-level sites with public access and areas that contribute to heavy snow or ice accumulations. Utilize Piggyback condensers whenever interior building locations must be used. To ensure adequate air supply, Emerson recommends that condensers be installed in an area with clean air, away from loose dirt and foreign matter that might clog the coil. In addition, condensers should not be located near steam, hot air or fume exhausts. Also, the condensers should be located no closer than 3 feet (1m) from a wall, obstruction or adjacent unit.

The condenser must not be installed in a pit.

The condenser must be installed on a level surface to ensure proper refrigerant flow. Condensers must be installed in vertical airflow orientation to ensure NEMA 3R rating of electrical box. The electrical-control enclosure is not designed for horizontal air-flow mounting and may allow water to enter the enclosure and damage components and/or create hazardous-voltage electrical short circuits. For roof installation, mount the condenser on suitable curbs or other supports in accordance with local codes. Use caution when installing condensers below the indoor unit. Fan Speed and VFD condensers must not be installed more than 15ft. (4.6m) below the indoor unit; Liebert Lee-Temp condensers should be installed above or at the same level as the indoor unit. Contact the factory for assistance in specifying sub-cooling coils to each circuit to extend these limits.

2.2 Dimensions and Weights

Table 2-1 Air-cooled condenser weights, dimensions and volume, approximate

Model	No. of Fans	Unit dry weight lb. (kg)	Domestic Packaging			Export Packaging		
			Shipping Weight lb. (kg)	Dimensions (LxWxH) in. (mm)	Volume ft ³ (m ³)	Shipping Weight lb. (kg)	Dimensions (LxWxH) in. (mm)	Volume ft ³ (m ³)
Standard Models								
083	1	295 (134)	450 (204)	62 x 36 x 63 (157 x 91 x 160)	81 (2.3)	557 (253)	63 x 37 x 64 (160 x 94 x 163)	86 (2.5)
104		315 (143)	470 (213)			577 (262)		
165	2	425 (193)	682 (309)	102 x 36 x 63 (259 x 91 x 160)	134 (3.8)	839 (381)	103 x 37 x 64 (262 x 94 x 163)	141 (4.0)
205		495 (225)	752 (341)			909 (412)		
251	3	500 (227)	859 (390)	142 x 36 x 63 (361 x 91 x 160)	186 (5.3)	1047 (475)	143 x 37 x 64 (363 x 94 x 163)	196 (5.6)
308		670 (304)	1029 (467)			1217 (552)		
415	4	840 (381)	1301 (590)	182 x 36 x 63 (462 x 91 x 160)	239 (6.7)	1558 (707)	183 x 37 x 64 (465 x 94 x 64)	251 (7.0)
510		1190 (540)	1651 (749)			1908 (865)		
616	6	1380 (626)	1823 (827)	142 x 36 x 94 (361 x 91 x 239)	278 (7.9)	2105 (955)	143 x 37 x 95 (363 x 94 x 241)	291 (8.2)
830	8	1750 (794)	2315 (1050)	182 x 36 x 94 (462 x 91 x 239)	356 (10.0)	2704 (1227)	183 x 37 x 95 (465 x 94 x 241)	372 (10.5)
1010		2640 (1197)	3205 (1454)			3594 (1630)		
Liebert Quiet-Line Models								
063	1	315 (143)	470 (213)	62 x 36 x 63 (157 x 91 x 160)	81 (2.3)	577 (262)	63 x 37 x 64 (160 x 94 x 163)	86 (2.5)
119	2	425 (193)	682 (309)	102 x 36 x 63 (259 x 91 x 160)	134 (3.8)	839 (301)	103 x 37 x 64 (262 x 94 x 163)	141 (4.0)
127		495 (225)	752 (341)			909 (412)		
143		515 (234)	772 (350)			929 (421)		
214	3	840 (381)	1199 (544)	142 x 36 x 63 (361 x 91 x 160)	186 (5.3)	1387 (629)	143 x 37 x 64 (363 x 94 x 163)	196 (5.6)
286	4	1105 (501)	1566 (710)	182 x 36 x 63 (462 x 91 x 160)	239 (6.7)	1823 (827)	183 x 37 x 64 (465 x 94 x 64)	251 (7.0)
409	6	1380 (626)	1823 (827)	142 x 36 x 94 (361 x 91 x 239)	278 (7.9)	2105 (955)	143 x 37 x 95 (363 x 94 x 241)	291 (8.2)
572	8	2430 (1102)	2995 (1359)	182 x 36 x 94 (462 x 91 x 239)	356 (10.0)	3384 (1535)	183 x 37 x 95 (465 x 94 x 241)	372 (10.5)
R-410A Models								
28K	1	325 (147)	480 (218)	62 x 36 x 63 (157 x 91 x 160)	81 (2.3)	587 (266)	63 x 37 x 64 (160 x 94 x 163)	86 (2.5)
60K	2	475 (215)	732 (332)	102 x 36 x 63 (259 x 91 x 160)	134 (3.8)	889 (403)	103 x 37 x 64 (262 x 94 x 163)	141 (4.0)
90K	3	675 (306)	1034 (469)	142 x 36 x 63 (361 x 91 x 160)	186 (5.3)	1222 (554)	143 x 37 x 64 (363 x 94 x 163)	196 (5.6)

Table 2-2 Liebert Lee-Temp™ receiver weights

Condenser Model #	Receiver Part #	Receivers per Condenser	Weight per Receiver lb. (kg)
Standard Models			
DCSL083	1C19982P1	1	100 (45)
DCSL104	1C19982P1		100 (45)
DCSL165	W-0050		125 (57)
DCSL205	W-0050		125 (57)
DCSL251	W-0050		125 (57)
DCSL308	W-0060		145 (66)
DCSL415	185011P1		260 (118)
DCSL616	W-0410 ¹		200 (91)
DCSL616	179701P1 ²		424 (192)
DCDL104	1C19982P1	2	100 (45)
DCDL165	1C19982P1		100 (45)
DCDL205	W-0050		125 (57)
DCDL251	1C19982P1		100 (45)
DCDL308	W-0050		125 (57)
DCDL415	W-0060		145 (66)
DCDL510	W-0410		200 (91)
DCDL616	W-0060		145 (66)
DCDL830	185011P1		260 (118)
Liebert Quiet-Line™ Models			
DCSL063	1C19982P1	1	100 (45)
DCST119	W-0050		125 (57)
DCSL127	W-0050		125 (57)
DCSL143	W-0060		145 (66)
DCST214	W-0410		200 (91)
DCST286	W-0410		200 (91)
DCDL119	1C19982P1	2	100 (45)
DCDL127	1C19982P1		100 (45)
DCDL143	W-0050		125 (57)
DCDT214	W-0050		125 (57)
DCDL286	W-0060		145 (66)
DCDT409	W-0410		200 (91)
DCDT572	W-0410	200 (91)	
R-410A Models			
DCSL28K	195315P1	1	125 (57)
DCSL60K	195316P1		145 (66)
DCSL90K	196702P1		200 (91)

1. Match-up for 35 to 105°F (2 to 41°C) design temperature range.
2. Match-up for -30 to 105°F (-34 to 41°C) design temperature range.

Figure 2-1 Condenser planning dimensional data—1- and 2-fan units

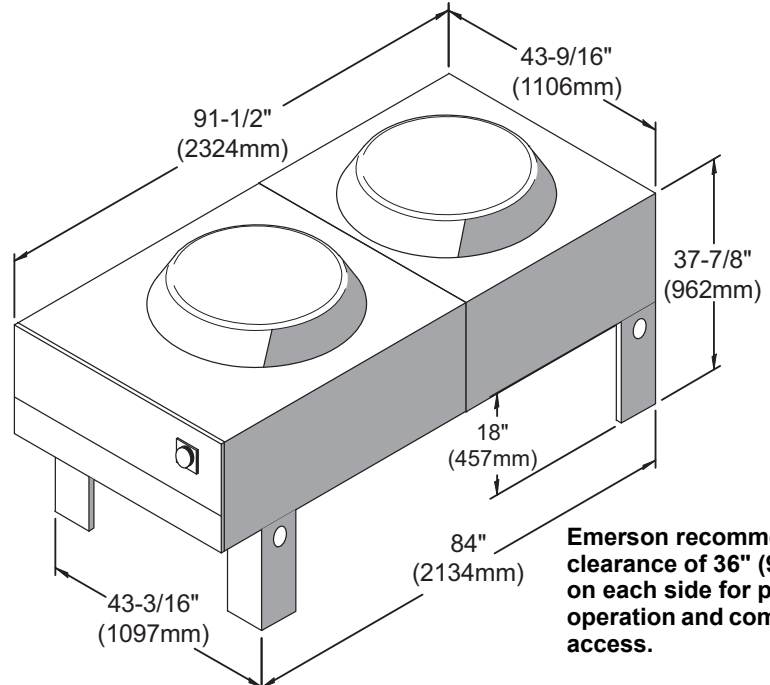
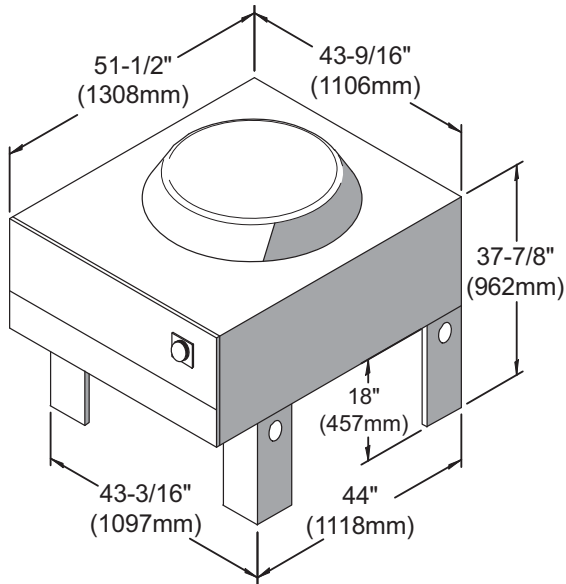

Note:
Overall height to the top of fan guard
43-1/8" (1095mm)

Emerson recommends a
clearance of 36" (915mm)
on each side for proper
operation and component
access.

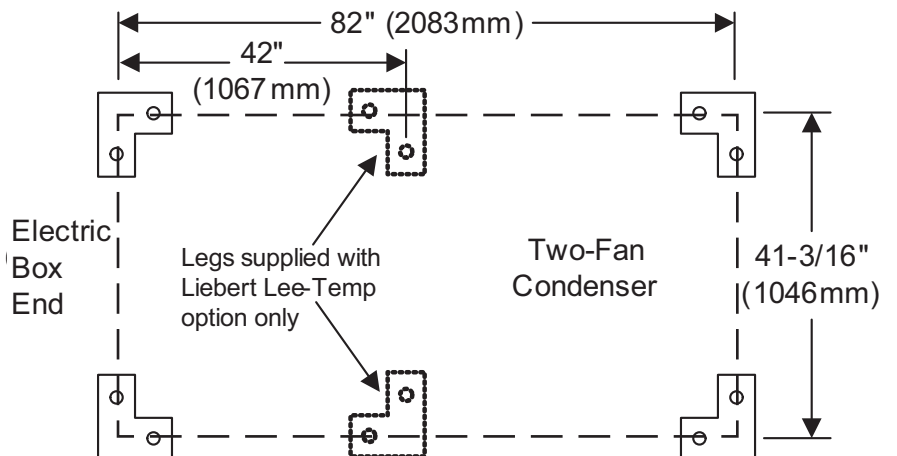
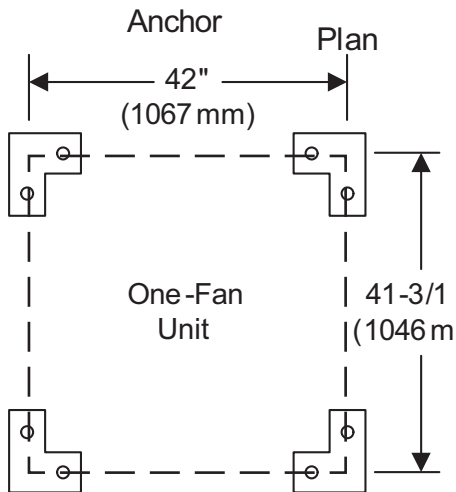

See Figure 2-4 for typical condenser
footprint dimensions.

Figure 2-2 Condenser planning dimensional data—3- and 4-fan units

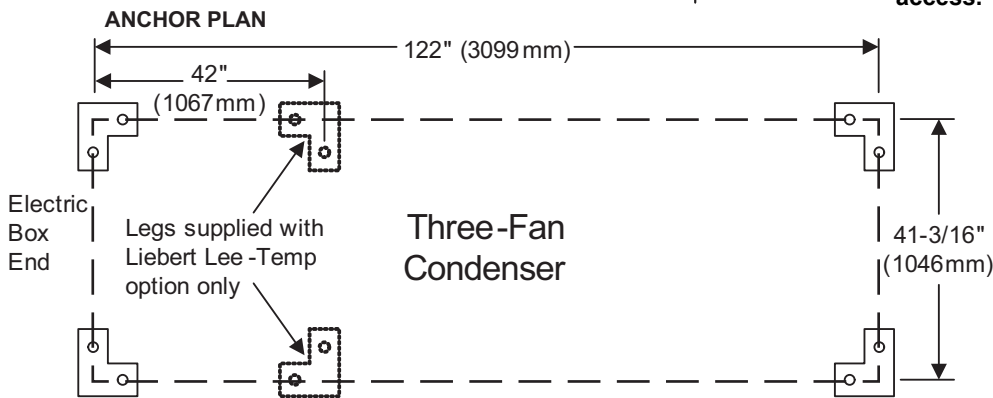
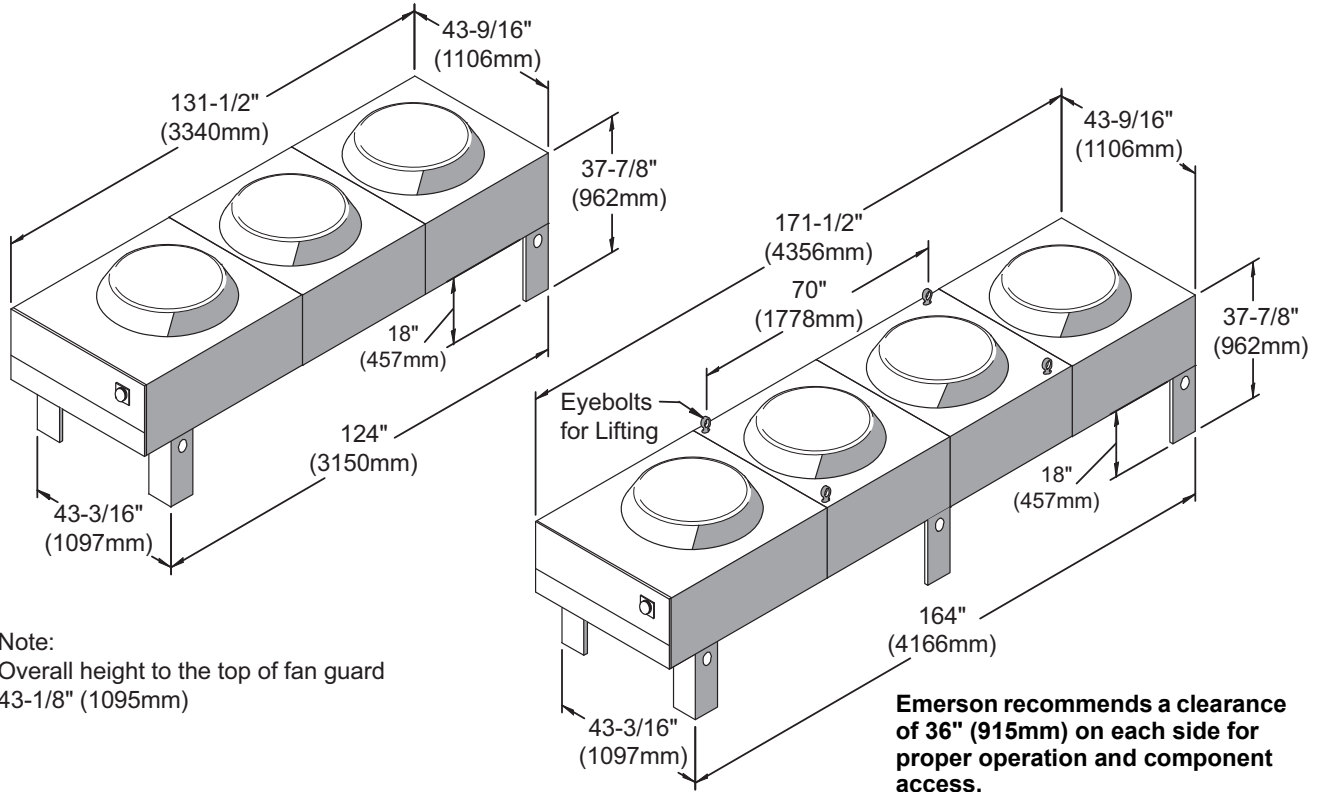

See Figure 2-4 for typical condenser footprint dimensions.

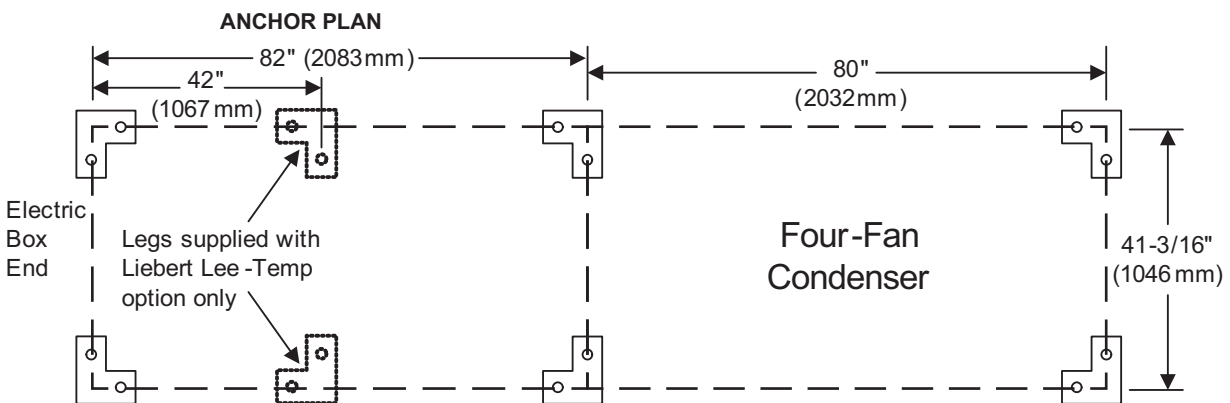
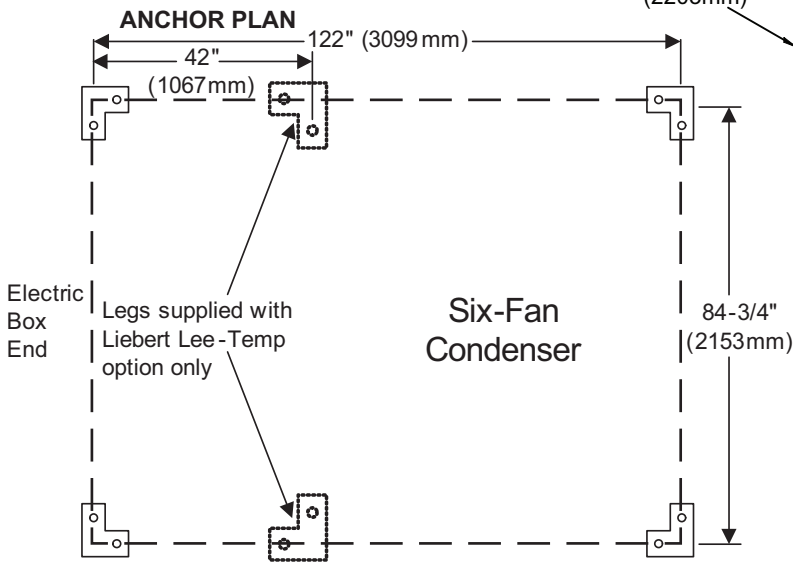
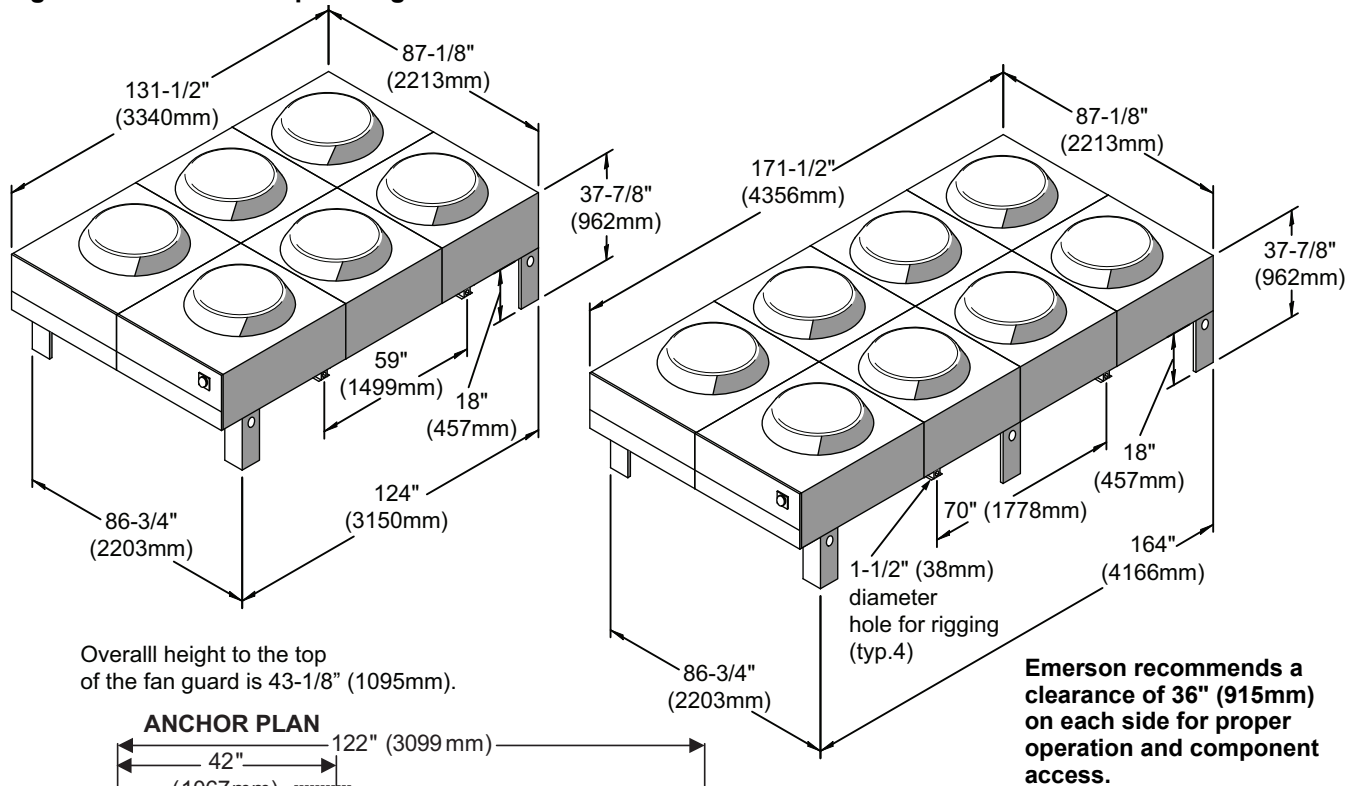

Figure 2-3 Condenser planning dimensional data—6- and 8-fan units



See Figure 2-4 for typical condenser footprint dimensions.

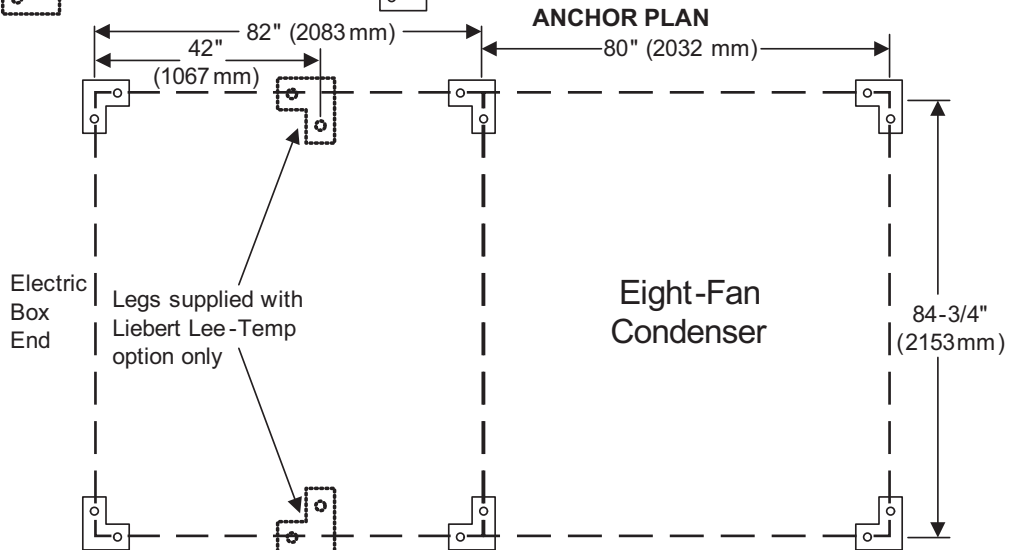
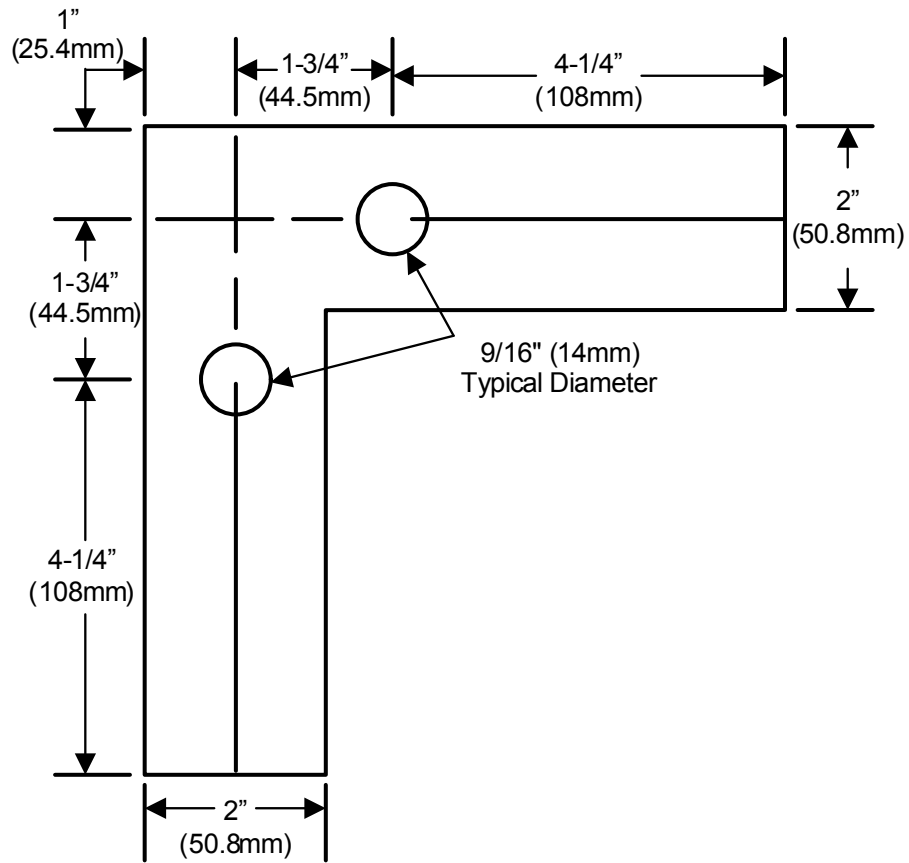

Figure 2-4 Typical fin/tube condenser footprint—dimensions



Page intentionally left blank.

3.0 Inspection and Installation

SAFETY INFORMATION



WARNING

Risk of improper handling. Can cause equipment damage, injury or death.

Read all of the following instructions before attempting to move, lift, remove packaging from or preparing unit for installation.



WARNING

Risk of heavy unit falling or tipping over. Can cause property damage, serious injury or death.

Confirm that all components of the lifting system are rated for the weight of the condenser by an OSHA Certified rating organization before attempting to lift and/or move the condenser. See **Tables 2-1** and **2-2** for the condenser weights.



CAUTION

Risk of contact with sharp edges, splinters and exposed fasteners. Can cause personal injury.

Only properly trained and qualified personnel wearing appropriate safety headgear, gloves, shoes and glasses should attempt to move, lift, remove packaging from or prepare unit for installation.

NOTICE

Risk of improper forklift handling. Can cause unit damage.

Keep the forklift tines level and at a height that will fit under the skid.

NOTICE

Risk of improper storage. Can cause unit damage.

Keep unit protected from contact damage.

3.1 Equipment Inspection

Upon arrival of the unit and before unpacking, verify that the labeled equipment matches the Bill of Lading. Carefully inspect all items for either visible or concealed damage. Report any damage immediately to the carrier and your local Emerson representative. File a damage claim with the carrier and send a copy to your local Emerson representative.

3.1.1 Packing Material

All material used to package this unit is recyclable. Please save it for future use or dispose of the material appropriately.

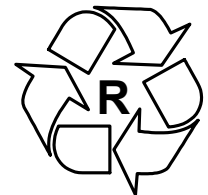
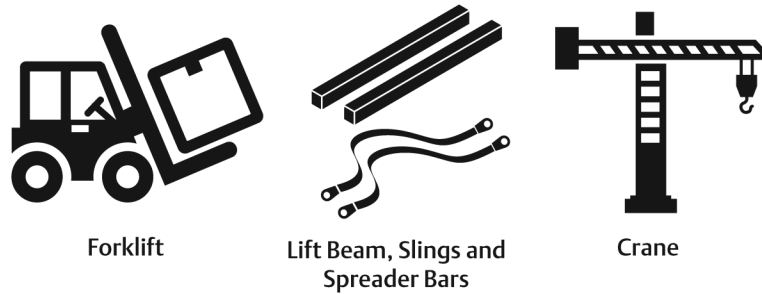

Figure 3-1 Equipment recommended for handling a Liebert condenser



WARNING

Risk of heavy unit falling or tipping over. Can cause property damage, serious injury or death.

Confirm that all components of the lifting system are rated for the weight of the condenser by an OSHA Certified rating organization before attempting to lift and/or move the condenser. See **Tables 2-1** and **2-2** for the condenser weights.

3.2 Handling Unit on the Skid

Transport unit using a fork lift or a crane with sling and spreader bars.

Using a forklift

NOTICE

Risk of improper forklift handling. Can cause unit damage.

Keep the forklift tines level and at a height that will fit under the skid.

- Make sure the forks (if adjustable) are spread to the widest allowable distance to still fit under the skid.
- Type of forklift used will depend on the terrain the unit is to be moved across during handling.
- Minimum forklift fork length:
 - for 1-fan and 2-fan units—48 in. (1219 mm)
 - for 3-fan and 4-fan units—72 in. (1829 mm)
 - for 6-fan units—72 in. (1829 mm)
 - for 8-fan units—96 in. (2438 mm)
- When moving the packaged unit, do not lift it any higher than 6 in. (152 mm). If the unit must be lifted higher than 6 in. (152 mm), great care must be exercised and no one may be closer than 20 ft (5 m) to the lift point.
- Using a forklift to move the unit, lift from one end only, and do not raise the end more than 6 in. (152 mm), **Figure 3-2**.

Figure 3-2 Forklift position with 1- to 8-fan condensers

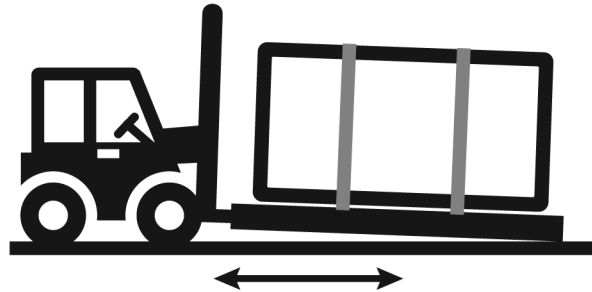

Using a Crane

- Verify that the crane and slings rated for the unit weight.
- Spreader bars must be used for sling stability and to keep the slings from pressing against the unit. Make sure spreader bars are wider than the unit.
- Place the slings near the ends and in the middle of the unit, under the top deck boards of the skid.

3.3 Unit Storage

Store the condenser in the original packaging in an area protected from excessive dirt, debris and contact damage until final installation.

3.4 Unpacking the Condenser—All Unit Sizes



CAUTION

Risk of contact with sharp edges, splinters and exposed fasteners. Can cause personal injury.

Only properly trained and qualified personnel wearing appropriate safety headgear, gloves, shoes and glasses should attempt to move, lift, remove packaging from or prepare unit for installation.

Refer to **Figure 3-3** for the following steps:

1. For domestic packaging:
 - Remove the fastener clips from the top and sides of the unit.
 - Remove all screws and washers from the wooden fencing.
 - Remove the fence

– or –

For export packaging, remove the crate.

- Carefully remove the steel straps securing the unit to the skid.



WARNING

Risk of unsecured strap ends with sharp edges flying uncontrollably in any direction when cut. Can cause serious injury. Secure both ends of each strap when cutting and wear OSHA approved protective headgear, gloves and eye protection when working with the securing straps.

- Set the legs aside, but keep accessible.
 - Depending on the number of fans, more or less steel straps may be removed at this step.

Figure 3-3 Removing protective material

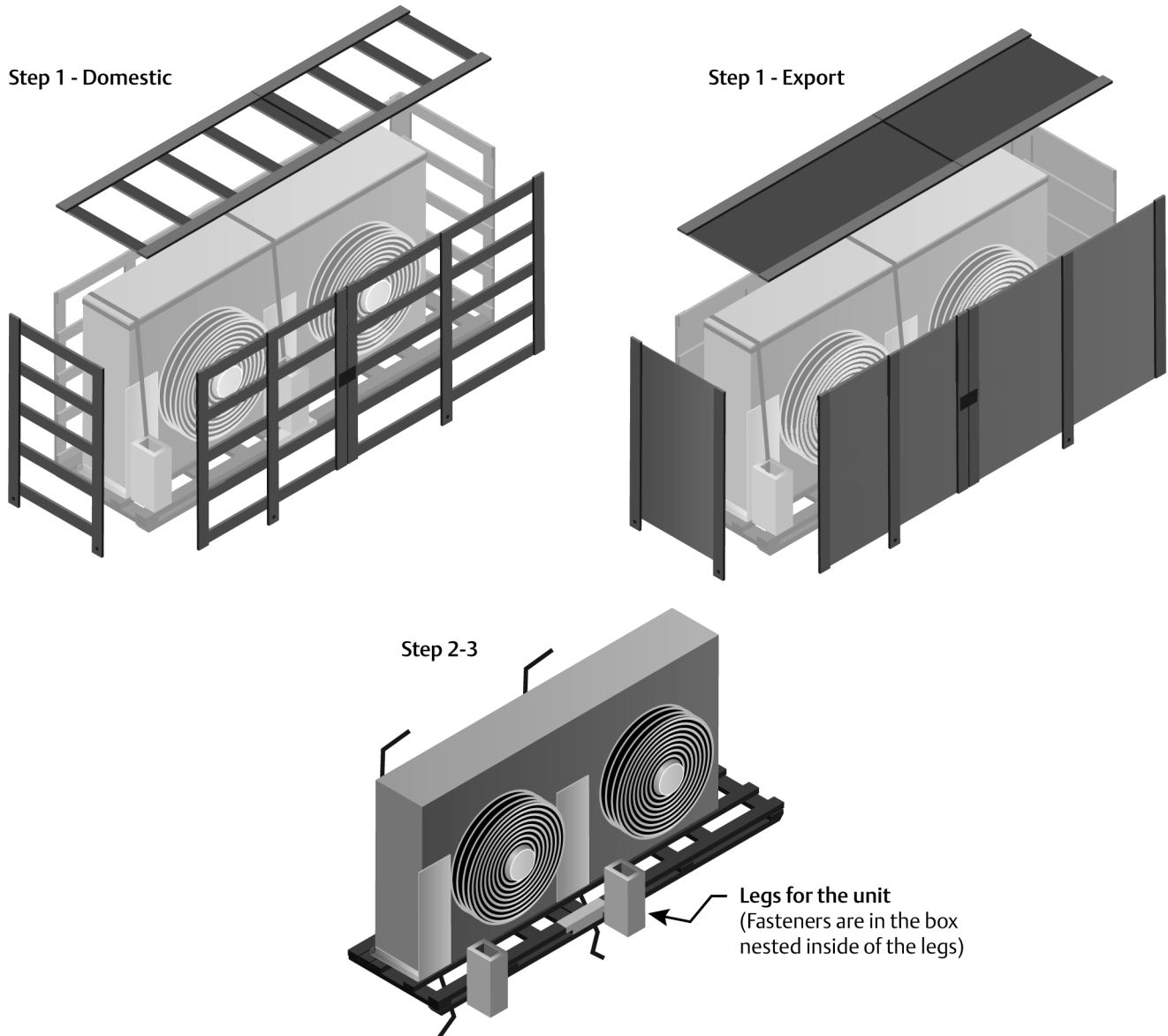

3.5 Preparing 1- to 4-fan Condenser for Moving and Installation

The following procedure is one method for removing a unit from the shipping skid. Other methods may be used, provided that they are safe for personnel, the condenser and other equipment.

1. Attach legs to the unit at indicated locations, using the fasteners provided with the legs, **Figure 3-4**.
 - Recommended tools for attachment is a 5/8" socket and ratchet.
 - More legs may be available for installation than are shown. This will depend on the unit type and number of fans.

Figure 3-4 Attaching legs to 1-fan to 4-fan condensers

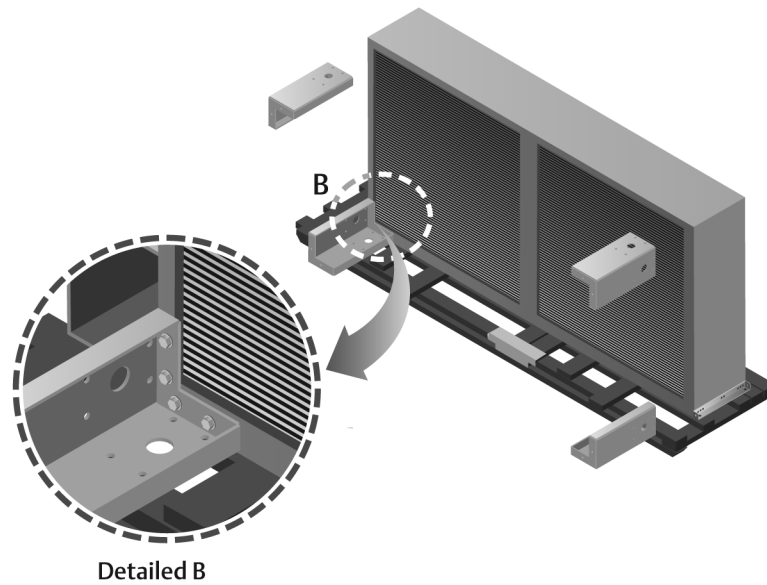

2. Place slings around the unit between the unit and the top deck boards of the skid as shown in **Figure 3-5**:
 - **1-fan, 2-fan and 3-fan units**: against the inside of the attached legs.
 - **4-fan units**: against the outside of the attached eye bolts.
3. Use spreader bars, a lift beam and a crane to lift the unit off the skid. Make sure spreader bars are wider than the unit.

NOTICE

Risk of improper lifting. Can cause equipment damage.

Make sure that the spreader bars wider are than the unit. If the spreader bars are too short, the slings may crush the unit.

Figure 3-5 Securing slings to 1- to 4-fan condensers for lifting off skid

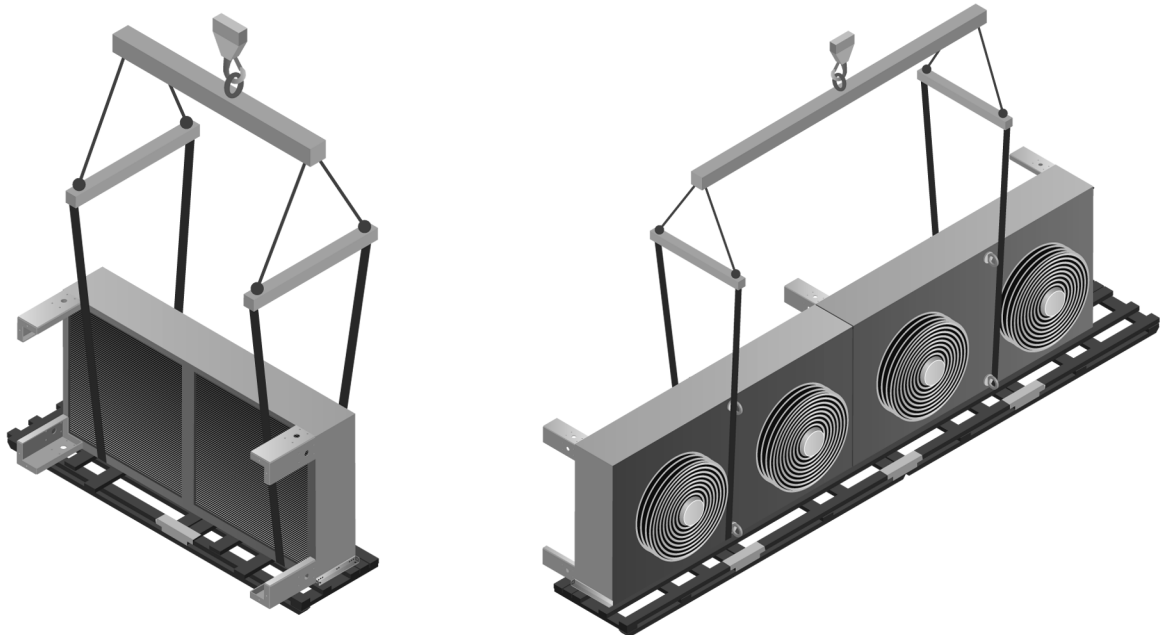

4. Lift the unit 24" (610mm) off the top deck of the skid.
5. Remove the skid from under the unit.
6. To rotate the unit, a mechanized method is recommended, but if one is not available, use a minimum of four properly-protected individuals to rotate the elevated unit 90 degrees so the unit legs are pointing toward the ground, **Figure 3-6**.
7. Set the upright unit on the ground so the legs support unit weight.
8. Remove the straps from around unit.

Figure 3-6 Rotate and set condenser on floor

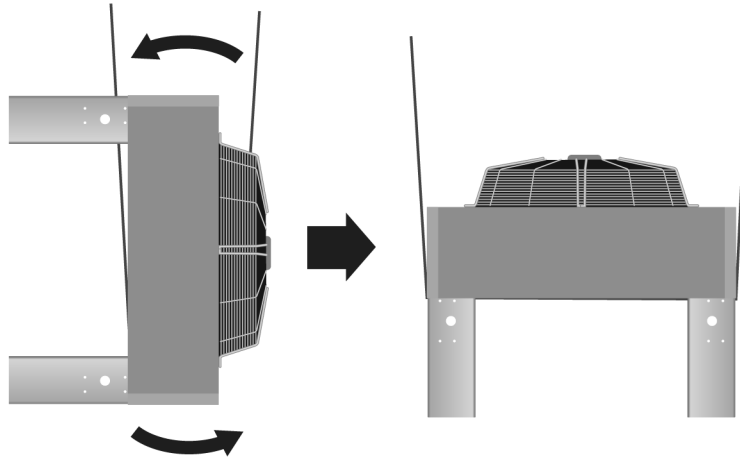

9. Refer to **Figure 3-7** to attach rigging for lifting. Spreader bars are still required. Make sure that the spreader bars are wider than the unit to prevent crushing force.
- **1-fan, 2-fan and 3-fan units:** Route the straps through the large holes in the side of the legs.
 - **4-fan units:** Secure straps or chains to the eye bolts on top of the unit.

NOTICE

Risk of improper lifting. Can cause equipment damage.

Make sure that the spreader bars wider are than the unit. If the spreader bars are too short, the slings may crush the unit.

The unit is ready to be lifted and moved to its installation location.

Figure 3-7 Rigging to lift 1- to 4-fan condensers

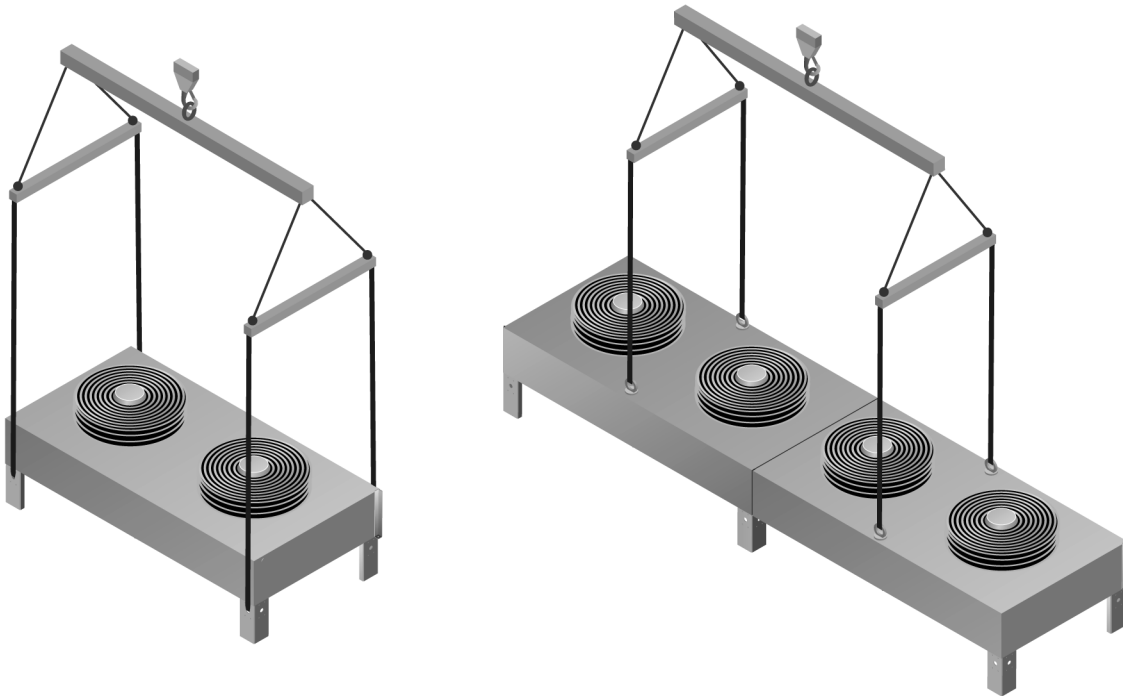

3.6 Preparing 6- and 8-fan condensers for Moving and Installation

The following procedure is one recommended process for removing a unit from the shipping skid. Other methods may be used, provided that the methods are safe for personnel, the condenser and equipment.

1. Refer to **Figure 3-8** to attach the legs to the higher side of the unit:
 - Use four (4) fasteners per leg. Fasteners are provided with the legs.
 - Recommended tools for attachment is a 5/8" socket and ratchet.
 - More legs may be required for installation than shown in **Figure 3-8**. Refer to the anchor plan corresponding to your unit's number of fans in **Figure 2-3**.

Figure 3-8 Attach legs to higher side of 6- or 8-fan condenser

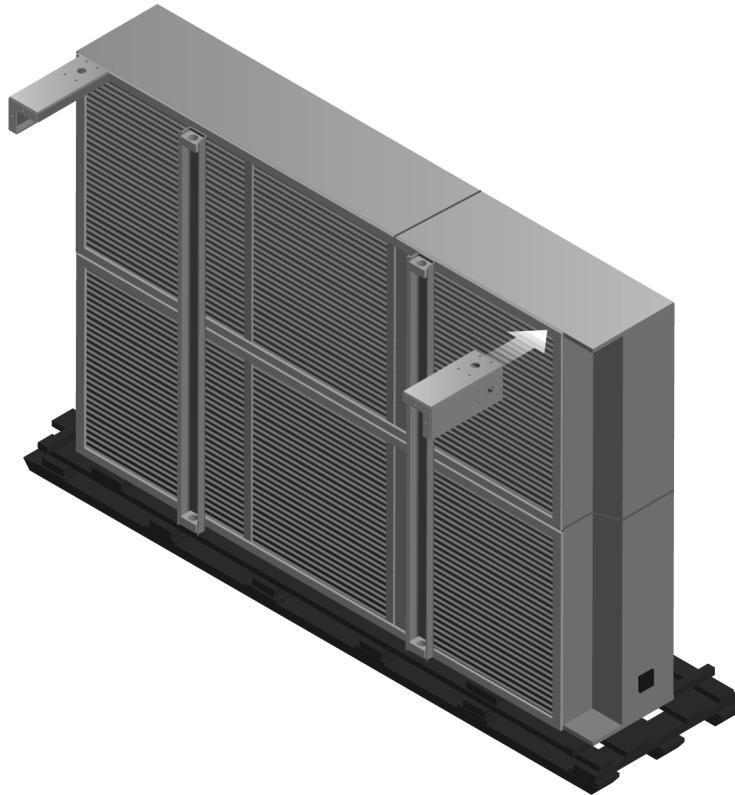

2. Attach slings or chains to the unit lift rails as shown in **Figure 3-9**.
 - Mechanically lower the unit in order to rest on the attached legs.
 - Make sure not to damage the opposite side of the unit.

Figure 3-9 Use sling to lower side with legs attached

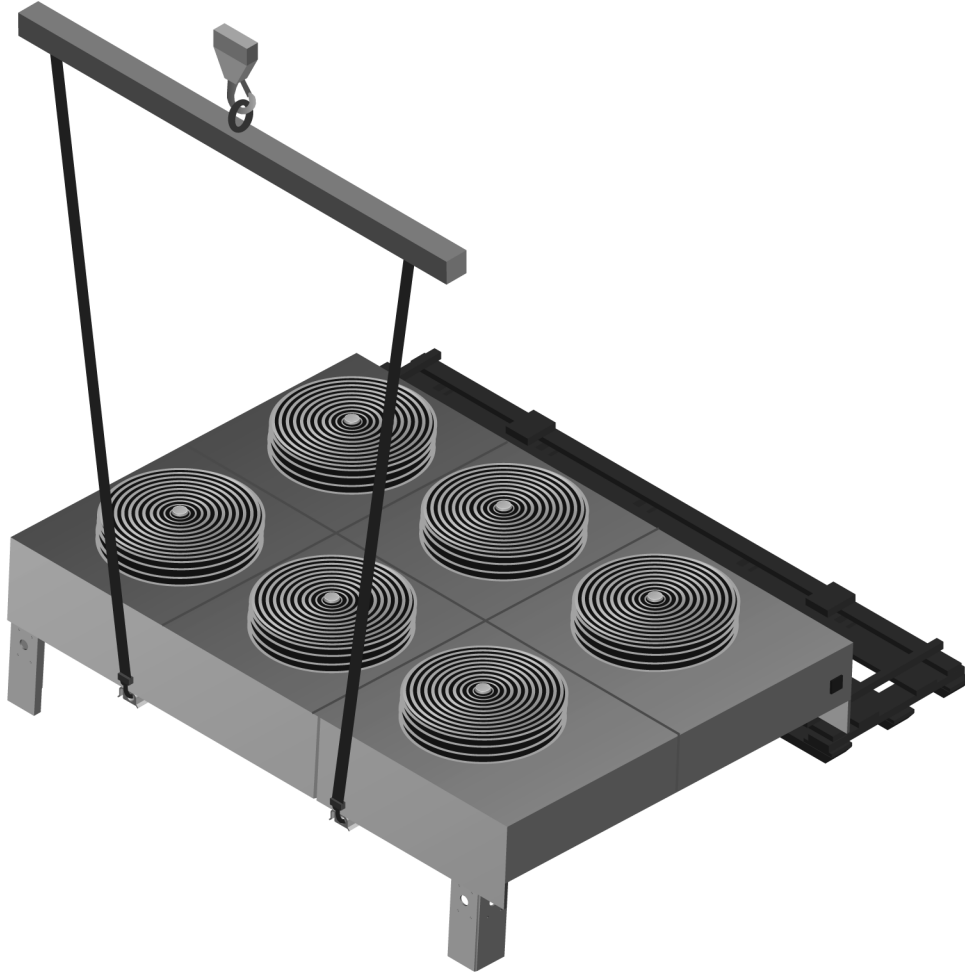

3. Move the slings or chains to the lift rail side that is resting on the skid, **Figure 3-10**.
 - Mechanically lift the unit to a point where the side being lifted is just high enough to allow for safe attachment of the remaining unit legs.
 - Move the skid out the way and attach remaining legs.

Figure 3-10 Move sling to side resting on skid and lift to remove skid/install legs

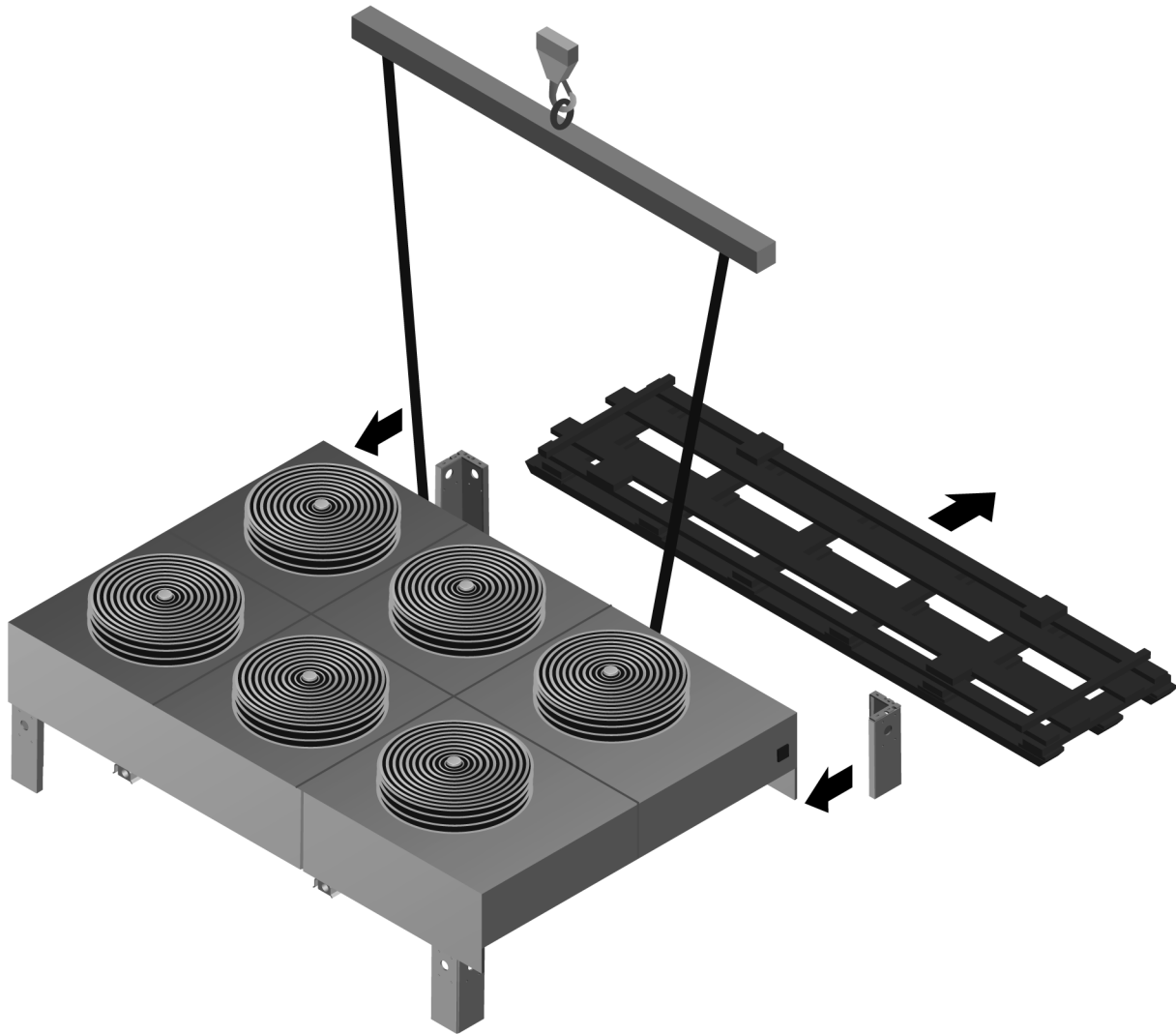

4. Set the upright unit on the ground so that the legs support the unit's weight.
5. Reposition and add straps and spreader bars to prepare the unit for lifting to installation location, **Figure 3-11**.
 - Use the support channels located under the unit to attach straps or chains.
 - Spreader bars are still required. Make sure spreader bars are wider than the unit to keep the straps from pressing on the sides of the unit.

NOTICE

Risk of improper lifting. Can cause equipment damage.

Make sure that the spreader bars wider are than the unit. If the spreader bars are too short, the slings may crush the unit.

The unit is ready to be lifted and moved to its installation location.

Figure 3-11 Rigging 6- and 8-fan condenser for lifting

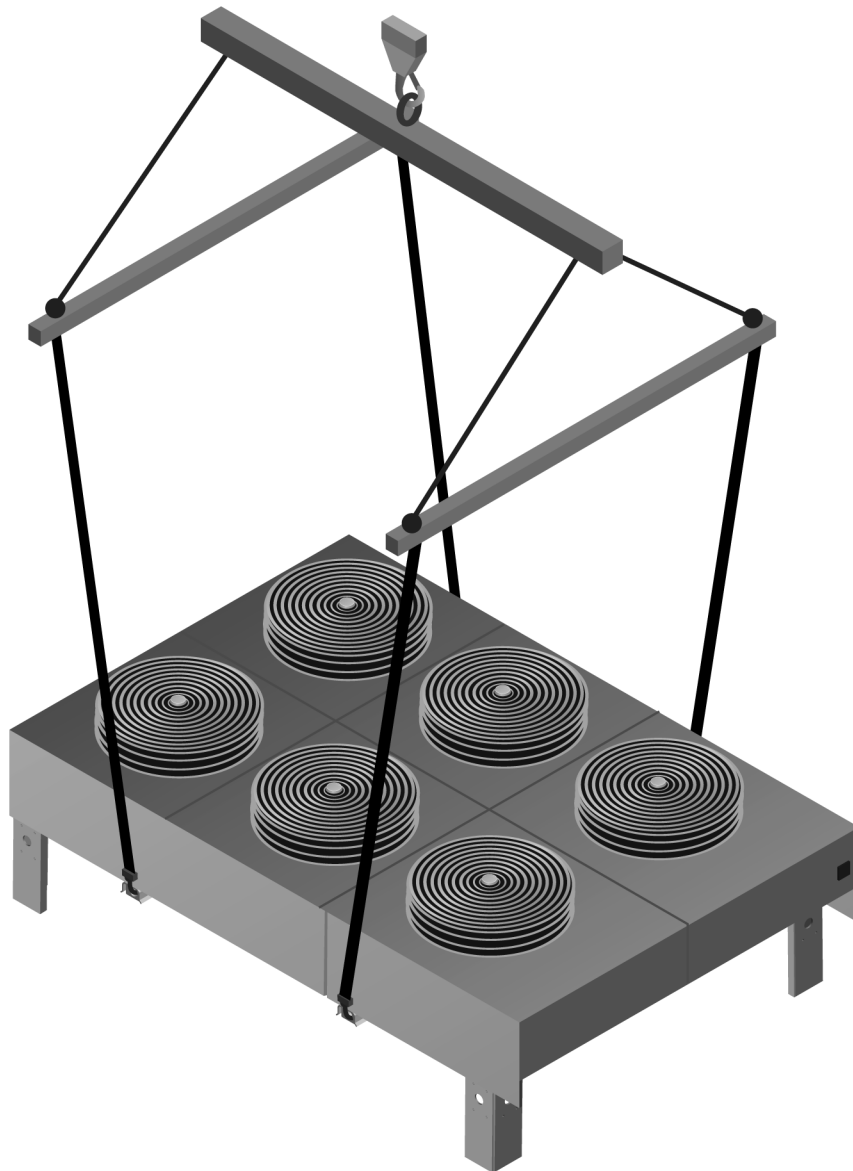

3.7 Mounting the Condenser

The condenser must be installed so that it is level within 1/2 in. (13 mm) to ensure proper refrigerant flow. For roof installation, mount the condenser on suitable curbs or other supports. Follow all local and national codes.

3.7.1 Standard Mounting Requirements

Secure the legs to the mounting surface using field-supplied 1/2-in.(13-mm) diameter Grade 5 bolts in each of the two 9/16-in. (14-mm) holes in each leg. See **Figures 2-1** through **2-4** for anchor dimensions.

Page intentionally left blank.

4.0 Piping



CAUTION

Risk of explosive discharge of high-pressure gas. Can cause injury.

Relieve system pressure and verify that the indoor and outdoor units are Off before making piping connections/disconnections.

Do not exceed the design pressure rating that is marked on the nameplate.

Do not install a shutoff valve between the compressor and the field-installed pressure relief valve.



WARNING

Risk of refrigerant system rupture or explosion from over-pressurization. Can cause equipment damage, injury or death.

Local building and plumbing codes may require that a fusible plug or other type of pressure relief device be installed in the system. Do not install a shutoff valve between the compressor and the field-installed relief device.

Consult local building and plumbing codes for installation requirements of additional pressure relief devices when isolation valves are field-installed as shown in **Figure 4-4**. Do not isolate any refrigerant circuits from over-pressurization protection.



NOTE

POE (polyol ester) oil, required with R407C/R410A and used with some R22 systems, is much more hygroscopic than mineral oils. This means that POE oil absorbs water at a much faster rate when exposed to air than previously used mineral oils. Because water is the enemy of a reliable refrigeration system, extreme care must be used when opening systems during installation or service. If water is absorbed into the POE oil, it will not be easily removed and will not be removed through the normal evacuation process. If the oil is too wet, it may require an oil change. POE oils also have a property that makes them act as a solvent in a refrigeration system.

NOTICE

Risk of improper installation and system contamination. Can degrade system performance and damage components.

Maintaining system cleanliness is extremely important to properly complete installation and to maintain system warranty. Failure to maintain system cleanliness during piping installation will clog filter driers and adversely affect other system components such as compressors and expansion valves. Refer to **4.1 - Piping Guidelines** for details.

4.1 Piping Guidelines

Indoor units and condensers both ship with an inert-gas holding charge. Do not vent the condenser until all refrigerant piping is in place, ready for connection to indoor unit and condenser.

- Use copper piping with a brazing alloy with a minimum temperature of 1350°F (732°C), such as Sil-Fos. Avoid soft solders such as 50/50 or 95/5.
- Use a flow of dry nitrogen through the piping during brazing to prevent formation of copper oxide scale inside the piping. When copper is heated in the presence of air, copper oxide forms. POE oil will dissolve these oxides from inside the copper pipes and deposit them throughout the system, clogging filter driers and affecting other system components.
- A pure dry nitrogen flow of 1-3 ft³/min (0.5-1.5 l/s) inside the pipe during brazing is sufficient to displace the air. Control the flow using a suitable metering device.
- Ensure that the tubing surfaces to be brazed are clean and that the ends of the tubes have been carefully reamed to remove any burrs.
- Ensure that all loose material has been cleaned from inside the tubing before brazing.
- Protect all refrigerant line components within 18" (460mm) of the brazing site by wrapping them with wet cloth or suitable heat sink compound.
- Isolate piping from building using vibration isolating supports.
- Refer to indoor unit user manual for appropriate piping sizes.
- Install traps on the hot gas (discharge) lines at the bottom of any rise over 5 feet high. If the rise exceeds 25 feet (7.5m), then install a trap in 20 foot (6m) increments or evenly divided.
- Pitch horizontal hot gas piping at a minimum rate of 1/2" per 10 ft. (42mm per 10m) so that gravity will aid in moving oil in the direction of refrigerant/oil flow.
- Consult factory if Liebert Lee-Temp condenser is below the evaporator or if Fan Speed/VFD Control Condenser is more than 15 ft (4.6m) below the evaporator.
- Consult factory if piping run exceeds 150 feet (46m) equivalent length.
- Keep piping clean and dry, especially on units with POE oil (R407C, R410A or R22 refrigerant).
- Avoid piping runs through noise-sensitive areas.
- Do not run piping directly in front of indoor unit discharge air stream
- Refrigerant oil – do not mix oil types or viscosities. Consult indoor unit for refrigerant type and oil requirements.
- Do not hang or suspend piping from the condenser-tube sheets protruding below the finned sections of the coil.



NOTE

Failure to use compressor oils recommended by compressor manufacturer will void compressor warranty. Consult Emerson or the compressor manufacturer for further recommendations or if you have questions about compressor oils.

Refer to ASHRAE Refrigeration Handbook for general good practices for refrigeration piping.

The Liebert indoor cooling unit has a factory-installed high-pressure safety switch in the high side refrigerant circuit. A pressure relief valve is provided with Liebert Lee-Temp condensers. Consult local building codes to determine if the Liebert Fan Speed Control (FSC) and VFD condensers will require field provided pressure relief devices. A fusible plug kit for Liebert FSC and VFD condensers is available for field installation.

4.2 Condenser Positioning guidelines

Table 4-1 Indoor unit maximum distance from the remote condenser—Fin/Tube condenser with or without Liebert Lee-Temp

Parameter	Maximum Distances, ft. (m)	
From R-407C cooling unit to condenser	150 (45.7) equivalent length	
From R-410A cooling unit to condenser	300 (91.4) equivalent length	
VFD/FSC condenser relative to indoor unit	Above: 60 (18.3)	Below: 15 (4.5)
Lee-Temp™/Quiet-Line condenser relative to indoor unit	Above: 60 (18.3)	Below: 0 (0)

Figure 4-1 Condenser positioning at the same level as indoor unit

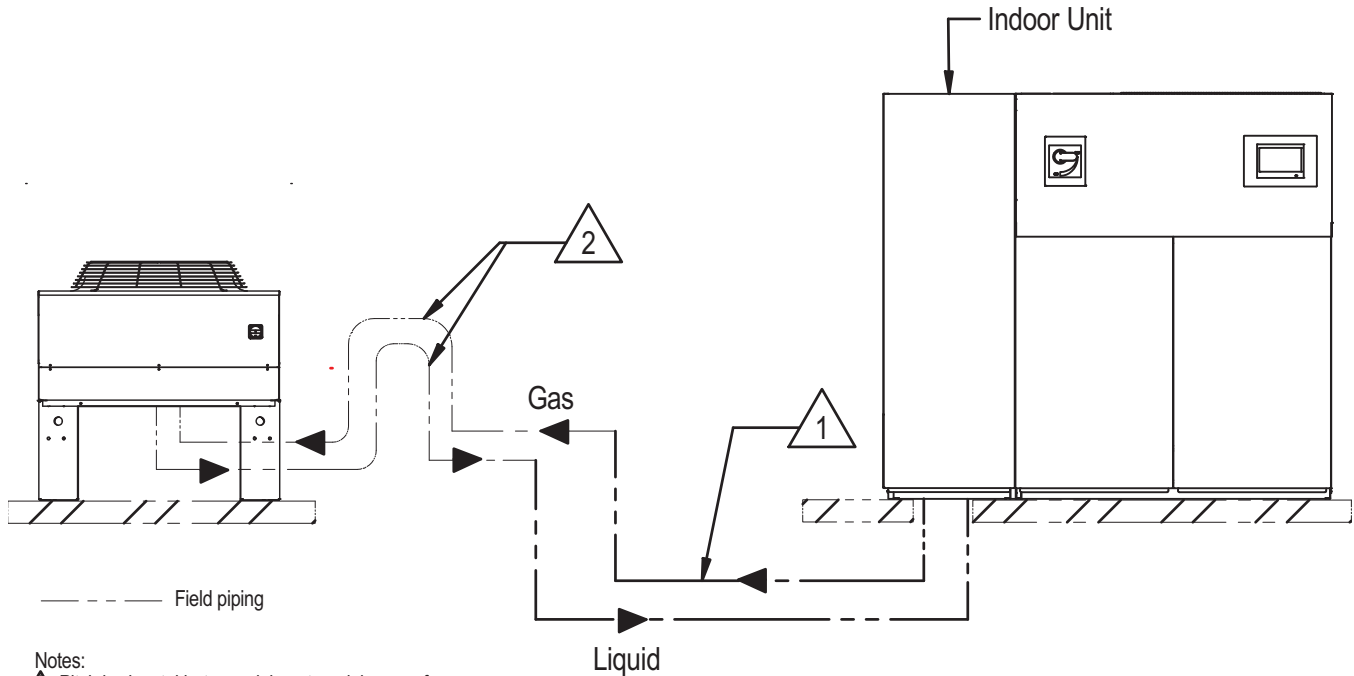

Notes:

- ⚠ Pitch horizontal hot gas piping at a minimum of 1/2" per 10 feet (42mm per 10m) so that gravity will aid in moving oil in the direction of the refrigeration flow.
 - ⚠ Inverted Trap on discharge & liquid lines to extend above base of coil by a minimum of 7 1/2" (190mm).
3. Single circuit system shown.

Figure 4-2 Condenser positioning above the indoor unit

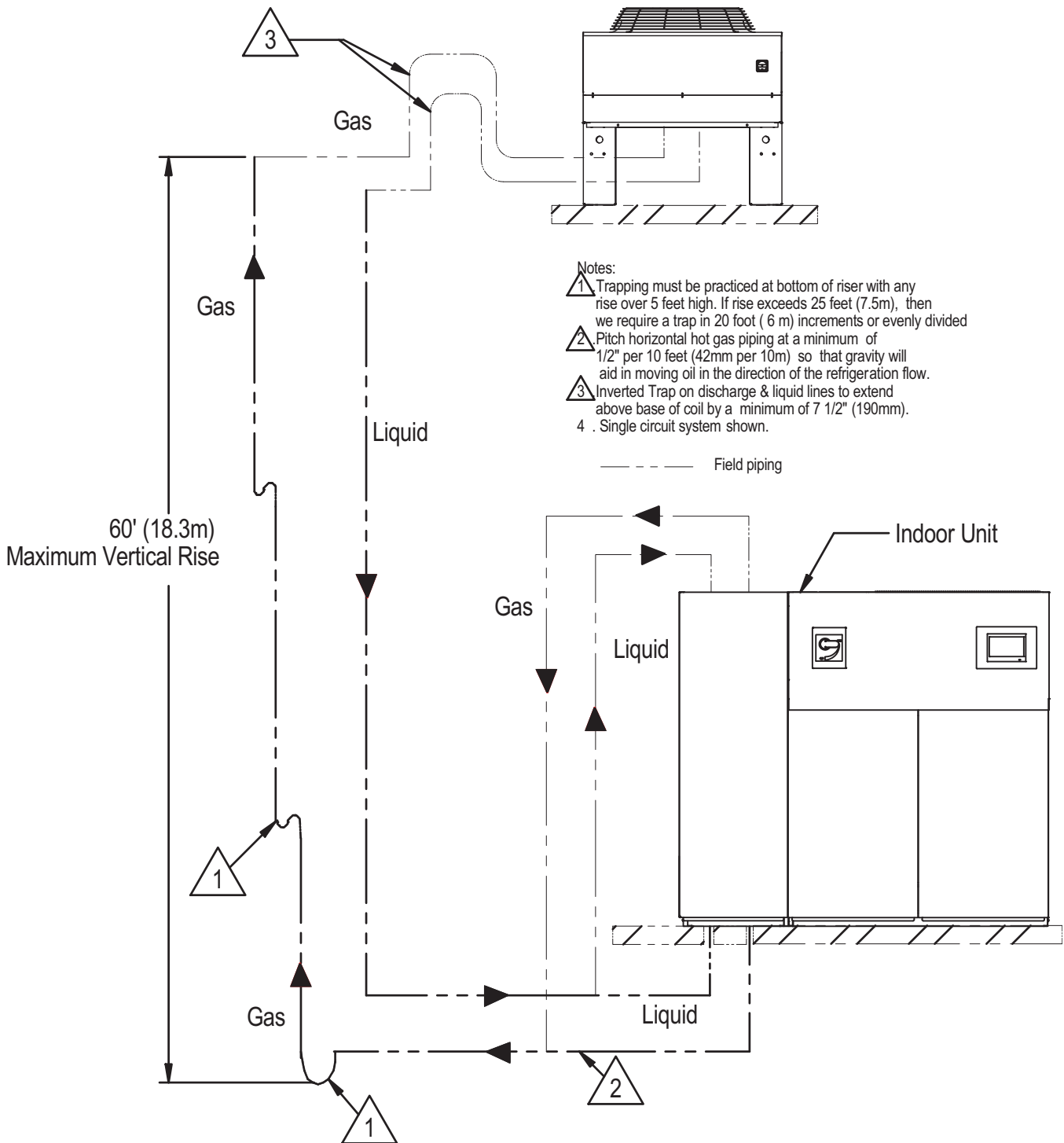

See Table 4-1 for maximum distances between, above, and below units.

Figure 4-3 Condenser positioning below indoor unit

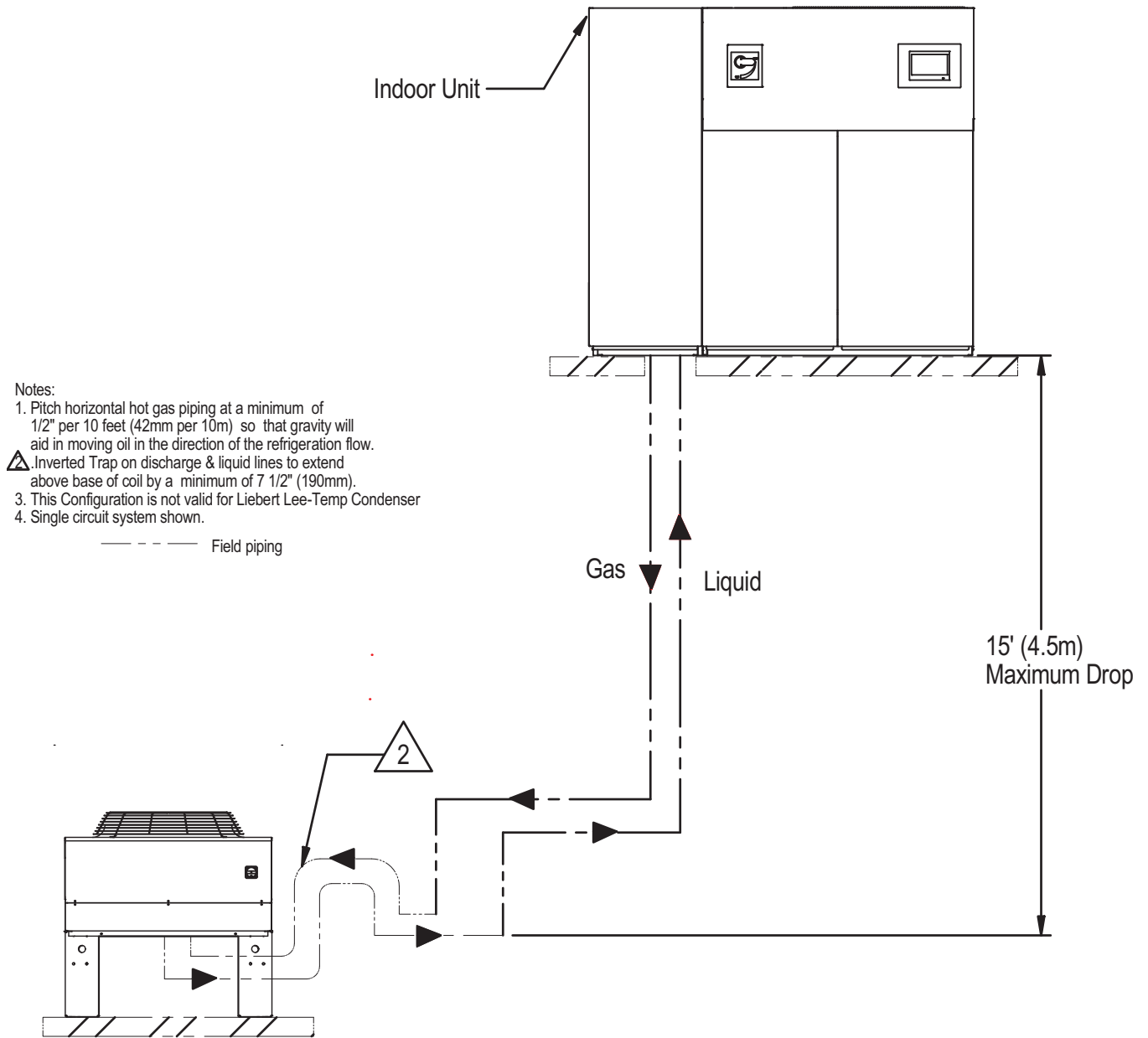

See **Table 4-1** for maximum distances between, above, and below units.

4.3 Field Piping Requirements

One discharge line and one liquid line must be field-installed for each circuit of the indoor unit and the outdoor condenser(s). Dual circuit condensers are available for most dual circuit indoor unit applications. Refer to **Figures 4-4** through **4-10** for additional field-installed piping needed at the condenser. This piping is needed for proper system performance and for installation/interconnecting receivers and head pressure control valves for Liebert Lee-Temp systems.



NOTE

Keep the evaporator unit and condenser closed with their factory charge of an inert gas while all field piping is installed. Keep the field piping clean and dry during installation, and do not allow it to stand open to the atmosphere.

When all the field interconnecting piping is in place, vent the condenser's an inert gas charge and connect to the field piping. Finally, vent the evaporator unit's inert-gas charge and make its piping connections last.

*Follow all proper brazing practices, including a dry nitrogen purge to maintain system cleanliness. Refer to **4.1 - Piping Guidelines**.*

Figure 4-4 Typical system configuration—indoor unit and outdoor condenser and field piping

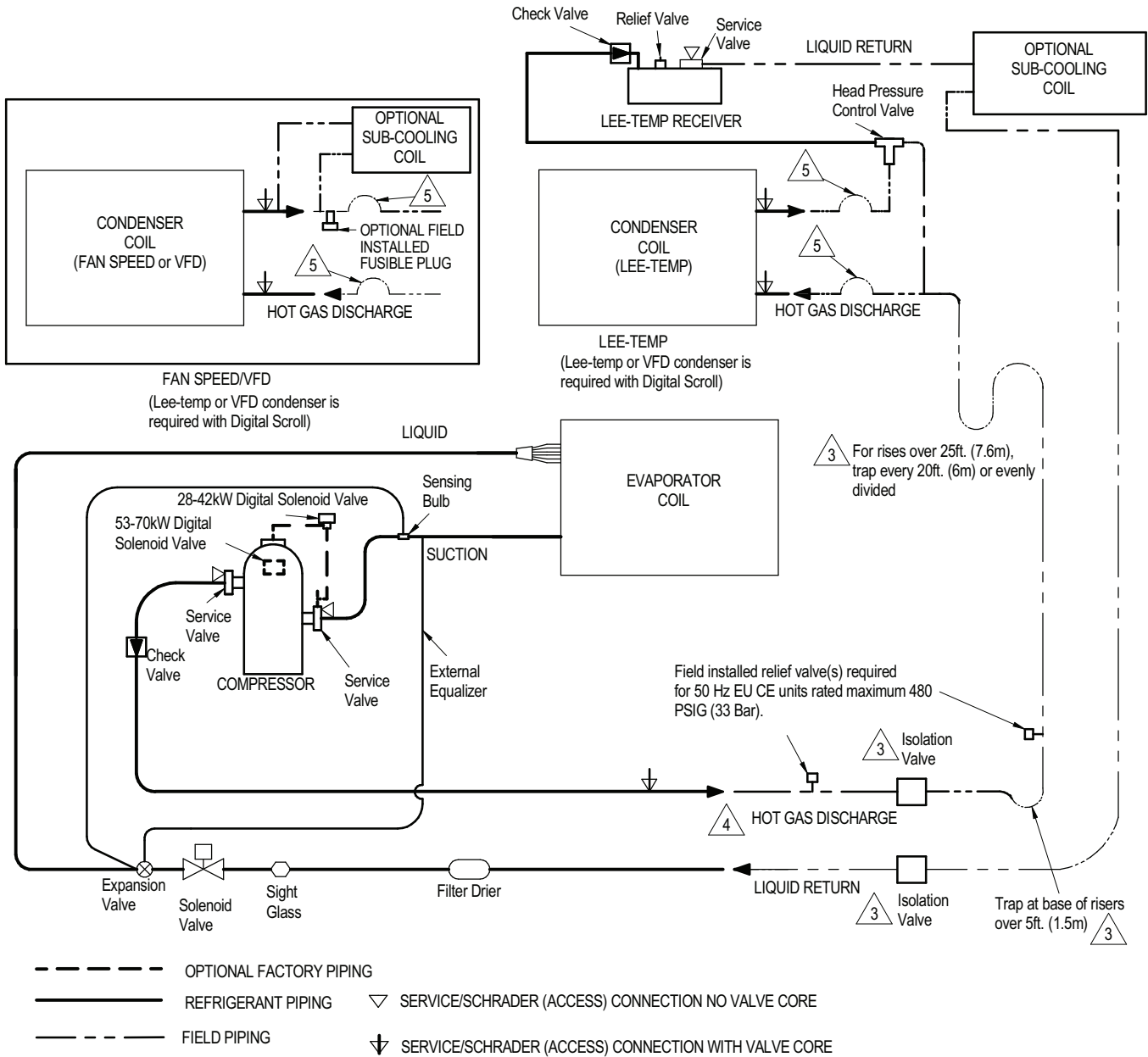

DPN000798
Rev. 8

4.4 Piping Connections

Figure 4-5 Single-circuit piping, VFD and Fan Speed Control, 1-4 fan condensers

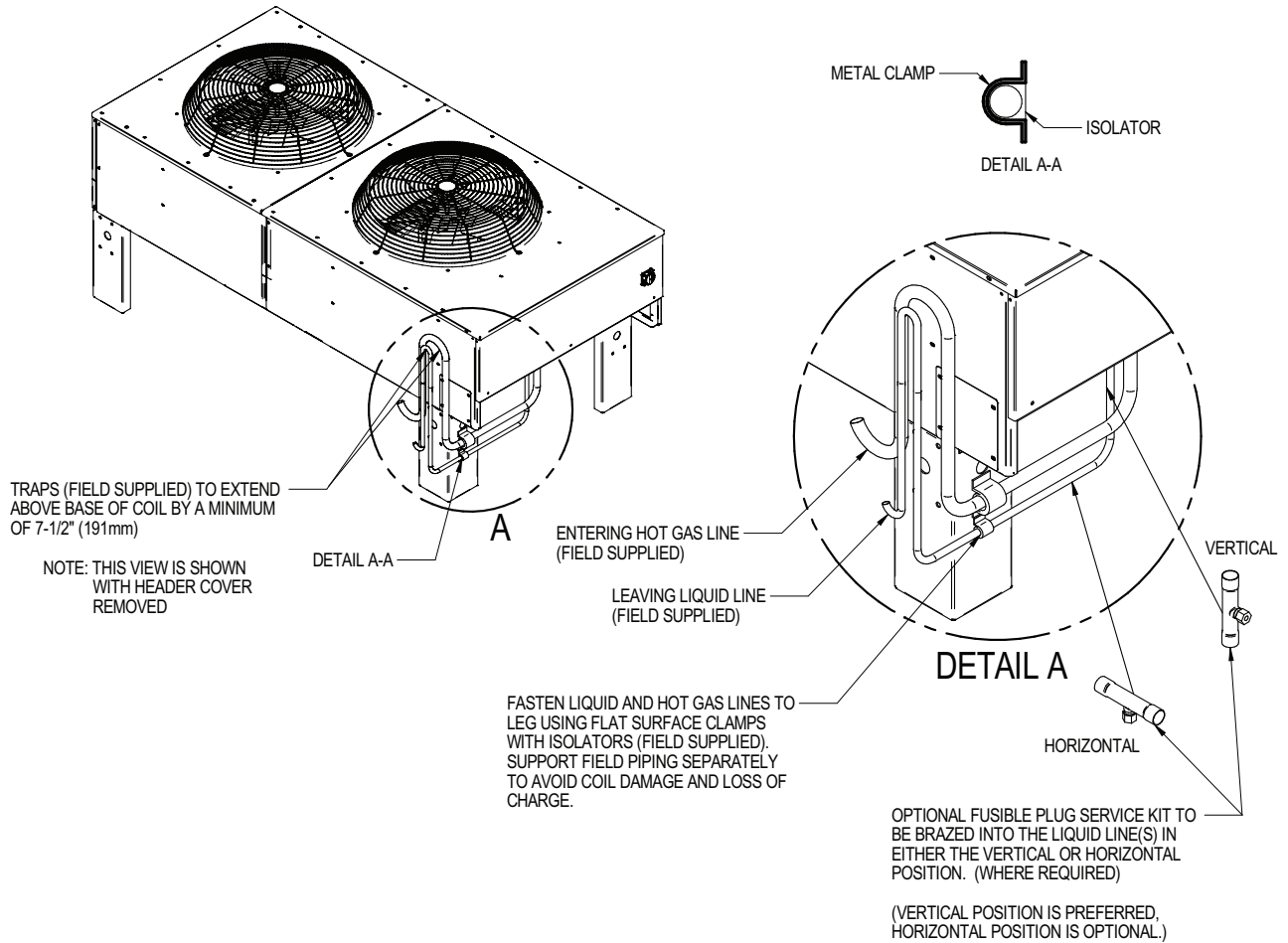

DPN000665
Rev. 5

Condenser Piping Connection Sizes, CU. OD.		
Model Number	Entering Hot-gas Line, in.	Returning Liquid Line, in.
TCSV28K	1-1/8	7/8
TCSV60K		
DCSF083, TCSV083	7/8	5/8
TCSV90K	1-1/8	7/8
DSCF104, TCSV104		5/8
DCSF165, TCSV165		7/8
DCSF205, TCSV205		
DCSF251, TCSV251		
DCSF308, TCSV308	1-5/8	1-1/8
DSCF415	1-3/8	
DSCF510	2-1/8	1-5/8

Figure 4-6 Single-circuit piping, Liebert Lee-Temp™ and Liebert Quiet-Line™ 1-4 fan condensers

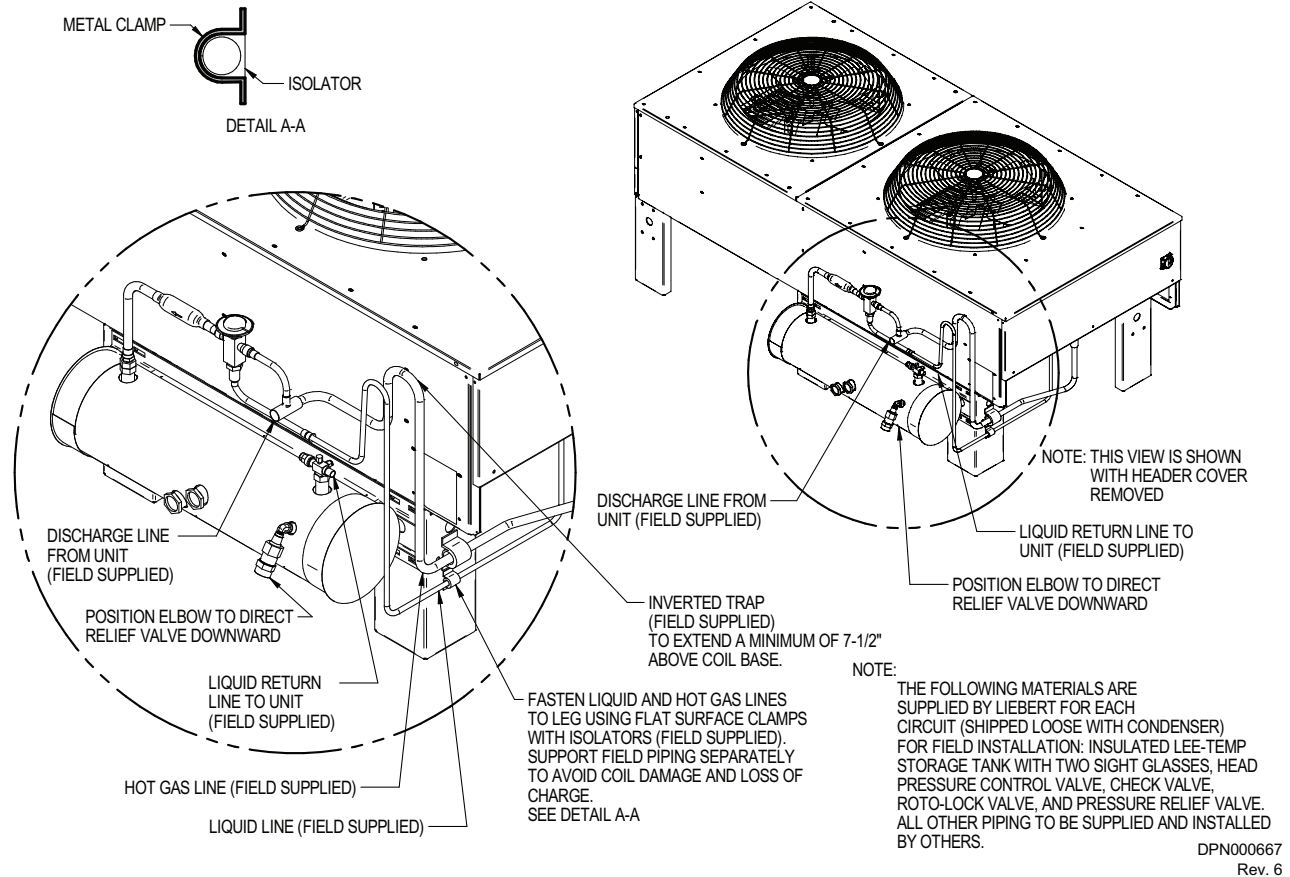

Condenser Piping Connection Sizes								
Model Number	Condenser Type	Condenser Connections ODS			Lee-Temp Connections IDS			
		Hot-gas Line, in.	Liquid Line, in.	Lee-Temp Receiver	Hot-gas Tee, in.	Liq to L-T Valve, in.	Receiver Out, in.	
DCSL28K	Standard	1-1/8	7/8	195315P1	1-1/8	5/8	7/8	
DCSL60K				195316P1				
DCSL083		7/8	5/8	1C19982P1	1-1/8	7/8	5/8	
DCSL90K		1-1/8	7/8	196702P1				
DCSL104			5/8	1C19982P1				
DCSL165		7/8	1-3/8	W-0050				1-1/8
DCSL205		1-5/8			1-1/8	185011P1		
DCSL251							1-3/8	
DCSL308		Quiet-Line	1-1/8	7/8	1C19982P1	1-1/8	7/8	5/8
DCSL415					1-3/8			
DCSL063	1-5/8		1-1/8	W-0060	1-3/8	1-1/8	7/8	
DCST119								5/8
DCSL127	2-1/8		1-1/8	W-0410	1-3/8	1-1/8	7/8	
DCSL143								7/8
DCST214								
DCST286								

Figure 4-7 Dual-circuit piping, VFD and Fan Speed Control, 1-4 fan condensers

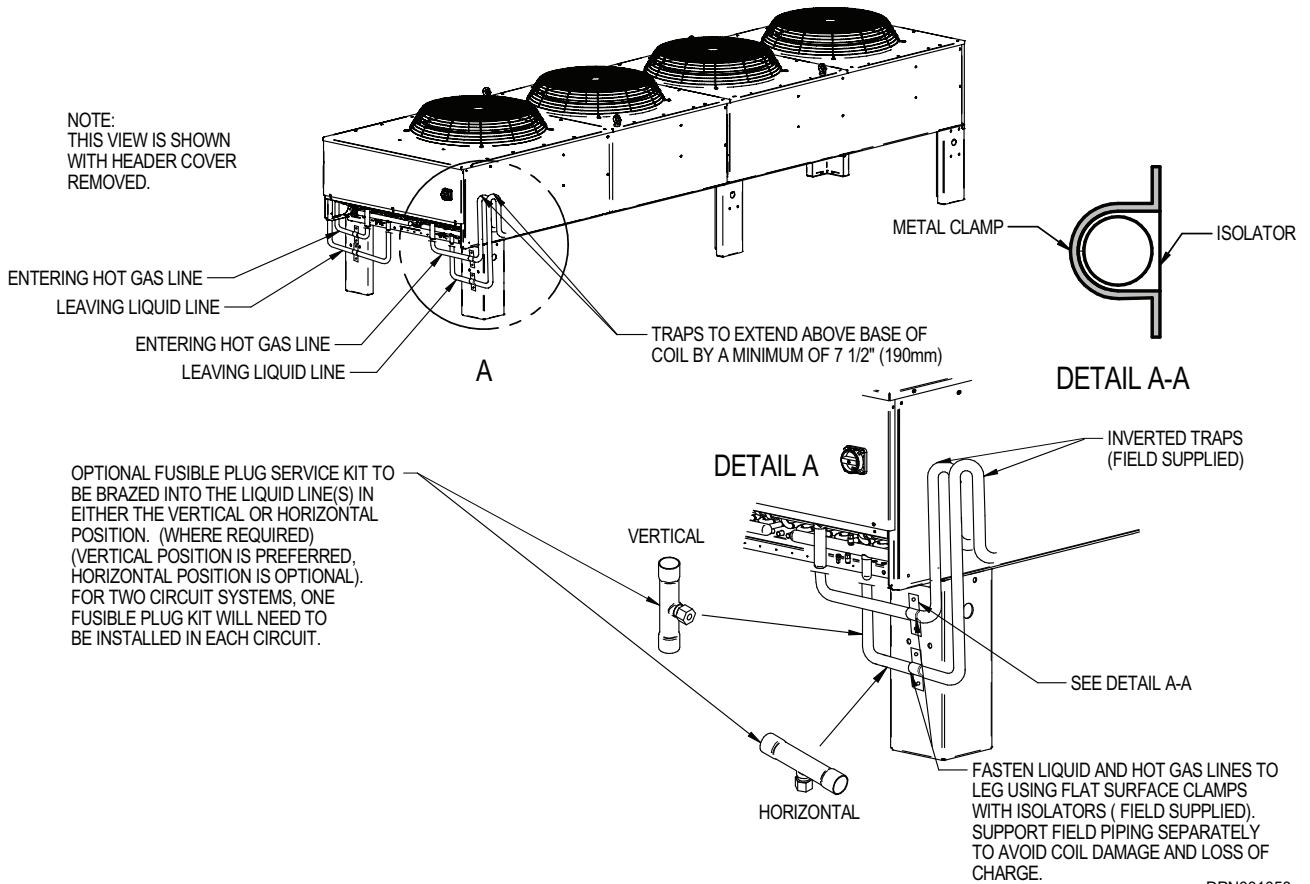

DPN001050
Rev. 3

Condenser Piping Connection Sizes, CU. OD. (2 per unit)		
Model Number	Entering Hot-gas Line, in.	Returning Liquid Line, in.
DCDF104	7/8	1/2
DCDF165, TCDF165		5/8
DCDF205, TCDV205	1-1/8	7/8
DCD251, TCDV251		
DCDF308, TCDV308	1-3/8	1-1/8
DCDF415, TCDV415		
DCDF510, TCDV510	1-5/8	

Figure 4-8 Dual-circuit piping, Liebert Lee-Temp™ and Liebert Quiet-Line™ 1-4 fan condensers

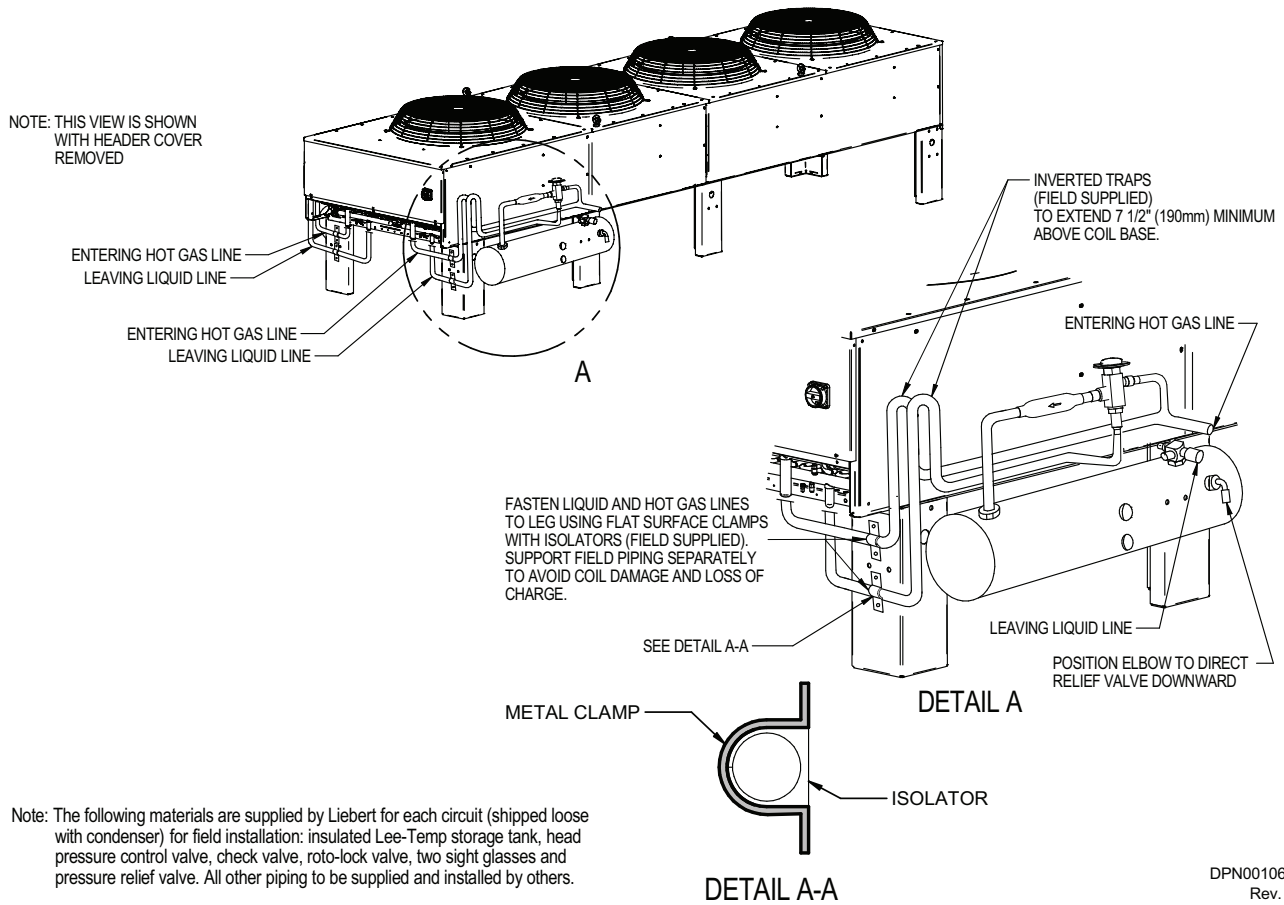

Model Number	Condenser Type	Condenser Connections ODS (2 per unit)		Lee-Temp Receiver	Lee-Temp Connections IDS (2 per unit)		
		Hot-gas Line, in.	Liquid Line, in.		Hot-gas Tee, in.	Liq to L-T Valve, in.	Receiver Out, in.
DCDL104	Standard	7/8	1/2	(2) 1C19982P1	1-1/8	7/8	5/8
DCDL165			5/8				
DCDL205		1-1/8	7/8	(2) W-0050	1-3/8	1-1/8	7/8
DCDL251				(2) 1C19982P1	1-1/8	7/8	5/8
DCDL308		1-3/8	1-1/8	(2) W-0050	1-3/8	1-1/8	7/8
DCDL415				(2) W-0060			
DCDL510				(2) W-0410			
DCDL119	Quiet-Line	7/8	5/8	(2) 1C19982P1	1-1/8	7/8	5/8
DCDL127		1-1/8	7/8	(2) W-0050	1-3/8	1-1/8	7/8
DCDL143							
DCDT214							
DCDL286							

Figure 4-9 Dual-circuit piping, Fan Speed Control, 6- and 8-fan condensers

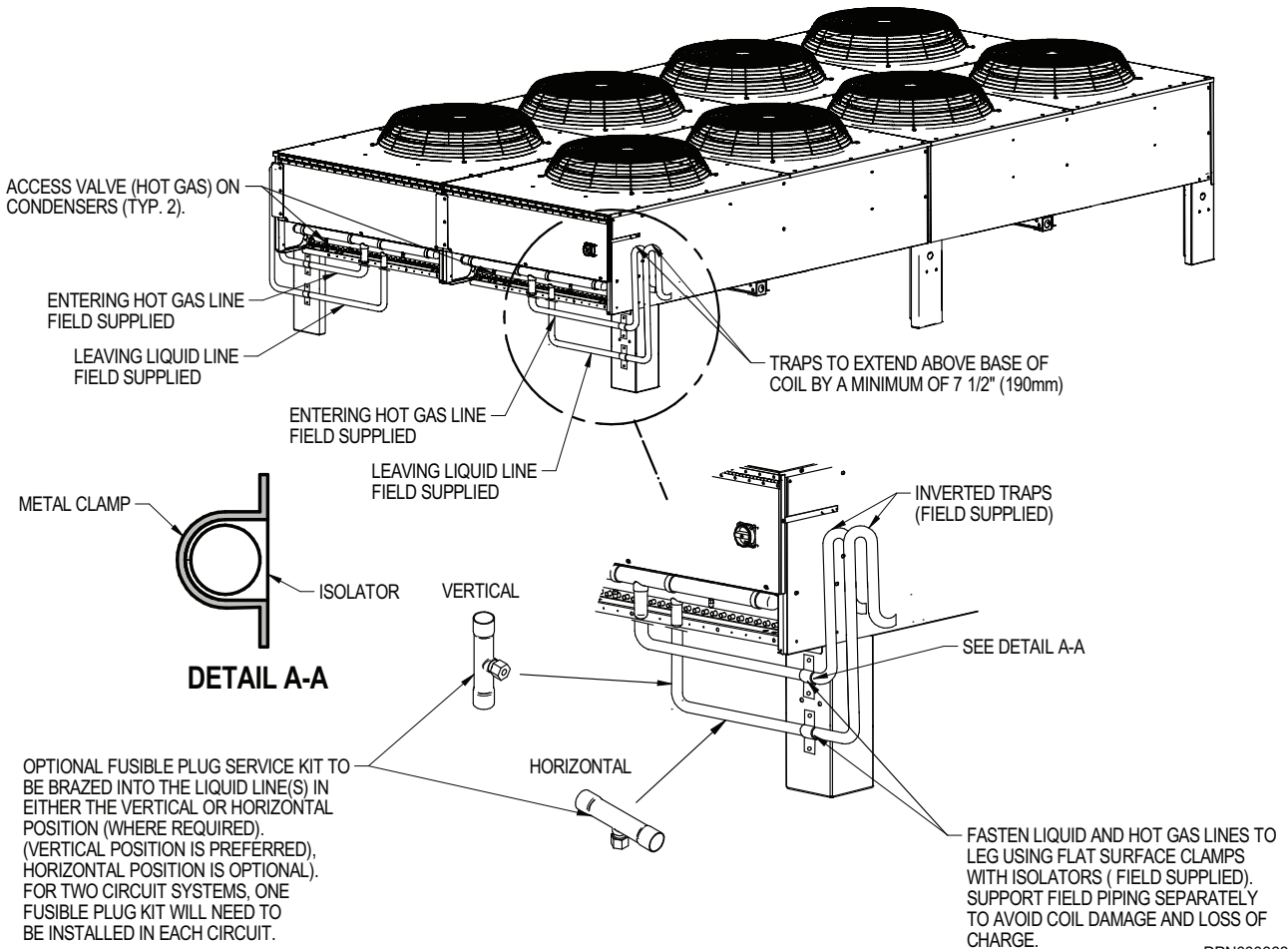

DPN000668
Rev. 4

Model Number	Number of Fans	Connection Sizes, ODS (2 per unit)	
		Entering Hot-gas Line, in.	Returning Liquid Line, in.
DCDF616	6	1-5/8	1-1/8
DCDF830	8	1-3/8	
DCDF1010		2-1/8	1-5/8

Figure 4-10 Dual-circuit piping, Liebert Lee-Temp and Liebert Quiet-Line 6- and 8-fan condensers

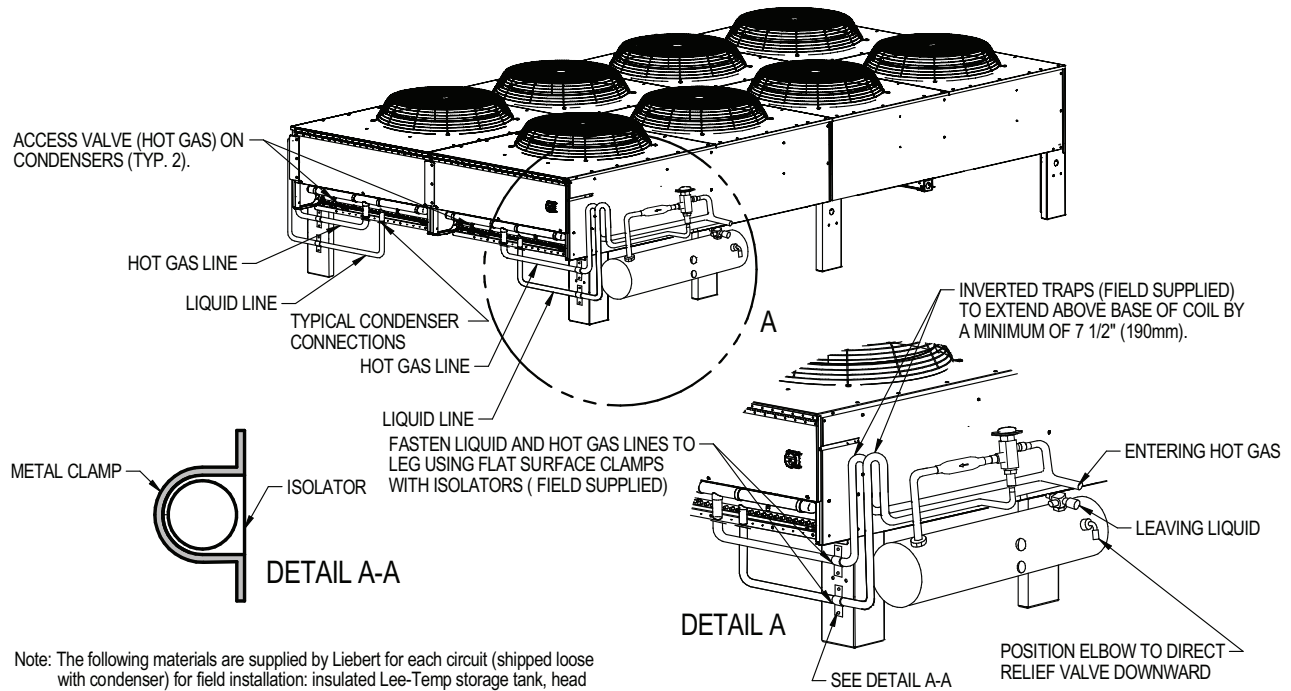

Note: The following materials are supplied by Liebert for each circuit (shipped loose with condenser) for field installation: insulated Lee-Temp storage tank, head pressure control valve, check valve, roto-lock valve, two sight glasses and pressure relief valve. All other piping to be supplied and installed by others.

DPN000670
Rev. 4

Model Number	Condenser Type	Fan Qty.	Condenser Connections ODS (2 per unit)		Lee-Temp Receiver	Lee-Temp Connections IDS (2 per unit)		
			Hot-gas Line, in.	Liquid Line, in.		Hot-gas Tee, in.	Liq to L-T Valve, in.	Receiver Out, in.
DCDL616	Standard	6	1-5/8	1-1/8	(2) W-0060	1-3/8	1-1/8	7/8
DCDL830		8	1-3/8		(2) 185011P1			
DCDT409	Quiet-Line	6	1-5/8		(2) W-0410			
DCDT572		8	2-1/8					

4.5 Refrigerant Planning Values

Planning for the refrigerant requirements of the completed system is the addition of the charges from Indoor Unit, Condenser (including Liebert Lee-Temp receiver, if used) and the interconnecting piping. **Tables 4-2** and **4-5** provide the approximate charge required for the condensers and the interconnecting piping. Consult indoor unit manuals for indoor unit charge requirements.

These values can be used for obtaining adequate refrigerant for the system, but should not be used for final charging. Consult indoor unit manual for charging procedures.

Table 4-2 R-22 and R-407C refrigerant required, approximate

Standard Condenser Models	Approximate R-22 Refrigerant Needed				Approximate R-407C Refrigerant Needed			
	Single Circuit lb. (kg)		Dual Circuit lb./circuit (kg/circuit)		Single Circuit lb. (kg)		Dual Circuit lb./circuit (kg/circuit)	
	FSC or VFD	Lee-Temp (includes receiver)	FSC or VFD	Lee-Temp (includes receiver)	FSC or VFD	Lee-Temp (includes receiver)	FSC or VFD	Lee-Temp (includes receiver)
083	5 (2.3)	27 (12.3)	3 (1.4)	N/A	5 (2.3)	26 (11.8)	3 (1.4)	N/A
104	8 (3.6)	39 (17.7)	7 (3.2)	21 (9.5)	8 (3.6)	37 (16.8)	7 (3.2)	20 (9.0)
165	15 (6.8)	53 (24.0)	5 (2.3)	27 (12.3)	15 (6.8)	50 (22.7)	5 (2.3)	26 (11.8)
205	20 (9.1)	76 (34.5)	7 (3.2)	56 (25.3)	19 (8.6)	72 (32.7)	7 (3.2)	54 (24.4)
251	19 (8.6)	75 (34.0)	10 (4.6)	38 (17.2)	18 (8.2)	71 (32.2)	10 (4.6)	36 (16.3)
308	29 (13.2)	113 (51.3)	11 (5.0)	58 (26.3)	28 (12.7)	107 (48.5)	11 (5.0)	55 (24.9)
415	54 (24.5)	210 (95.0)	25 (11.3)	107 (48.4)	51 (23.1)	200 (90.8)	24 (10.9)	102 (46.2)
510	72 (32.7)	N/A	30 (13.6)	149 (67.6)	68 (30.8)	N/A	29 (13.2)	142 (64.4)
616	N/A	N/A	27 (12.3)	113 (51.3)	N/A	See Table 4-3	26 (11.8)	108 (49.0)
830	N/A	N/A	53 (24)	210 (95.1)	N/A	N/A	51 (23.1)	200 (90.8)
1010	N/A	N/A	60 (27.2)	N/A	N/A	N/A	57 (25.9)	N/A
Liebert Quiet-Line Condenser Models								
063	N/A	39 (17.7)	N/A	N/A	N/A	37 (16.8)	N/A	N/A
119	N/A	50 (22.7)	N/A	27 (12.3)	N/A	48 (21.8)	N/A	26 (11.8)
127	N/A	76 (34.5)	N/A	38 (17.2)	N/A	72 (32.6)	N/A	36 (16.3)
143	N/A	126 (57.2)	N/A	64 (29.0)	N/A	120 (54.5)	N/A	61 (27.7)
214	N/A	161 (73.0)	N/A	81 (36.7)	N/A	153 (69.4)	N/A	77 (34.9)
286	N/A	196 (88.9)	N/A	125 (56.7)	N/A	186 (84.4)	N/A	119 (54.0)
409	N/A	N/A	N/A	152 (68.9)	N/A	N/A	N/A	148 (67.2)
572	N/A	N/A	N/A	196 (88.9)	N/A	N/A	N/A	186 (84.4)

Table 4-3 R-407C refrigerant required for DCSL616 condensers for Liebert XDC, approximate

Model #	Liebert Lee-Temp Receiver	Receiver Tank Length, in. (mm)	Refrigerant Per Circuit (inc. receiver), lb. (kg)
DCSL616	W-0410	48 (1219)	164 (75)
	179701P1	96 (2438)	254 (115.2)

Table 4-4 R-410A refrigerant required, approximate

Single Circuit Model	VFD lb. (kg)	Liebert Lee-Temp (inc. receiver) lb. (kg)
28K	7 (3.2)	41 (18.6)
60K	16 (7.3)	75 (34.0)
90K	25 (11.3)	109 (49.4)

Table 4-5 Interconnecting piping refrigerant charge

Line Size, O.D., in.	R-407C (R-22), lb/100 ft. (kg/30m)		R-410A, lb/100 ft. (kg/30m)	
	Hot Gas Line	Liquid Line	Hot Gas Line	Liquid Line
3/8	—	3.6 (1.6)	—	3.2 (1.4)
1/2	0.5 (0.2)	6.7 (3.0)	0.7 (0.3)	5.9 (2.7)
5/8	0.8 (0.4)	10.8 (4.8)	1.1 (0.5)	9.6 (4.3)
3/4	1.2 (0.5)	16.1 (7.2)	1.6 (0.7)	14.3 (6.4)
7/8	1.7 (0.8)	22.3 (10.0)	2.3 (1.0)	19.8 (8.8)
1-1/8	2.9 (1.3)	38.0 (17.0)	3.9 (1.7)	33.8 (15.1)
1-3/8	4.4 (2.0)	57.9 (25.9)	5.9 (2.6)	51.5 (23.0)
1-5/8	6.2 (2.8)	—	8.4 (3.7)	—

Data based on 50°F Evap, 15°F superheat, 125°F SCT, 10°F subcooling.
Per DPN003099 Rev. 0

4.5.1 Refrigerant Oil Addition Procedures

Consult the indoor unit's user or installation manual to determine whether additional oil is required for each circuit. Factors such as compressor, condenser type, piping lengths and total circuit refrigerant charge influence this requirement.

4.5.2 System Dehydration/Leak Test and Charging Procedures

Procedures for leak check and evacuation of the entire refrigeration system are contained in the indoor unit's user or installation manual. Use the proper manual section corresponding to the winter control system used on the condenser (VFD/Fan Speed Control or Liebert Lee-Temp Control) and the refrigerant to be charged into the system.

Page intentionally left blank.

5.0 Electrical Connections

5.1 Electrical Supply Preparation

Electrical service is required for all models. Refer to equipment nameplate regarding wire size and circuit protection requirements. Electrical service must conform to national and local electrical codes. Refer to **Figures 5-4, 5-5 and 5-6** for electrical service entrances into unit. Refer to electrical schematic when making connections.

Each unit is shipped from the factory with all internal unit wiring completed.

A manual, electrical-disconnect switch should be installed in accordance with local codes. Consult local codes for external disconnect requirements.

WARNING

Arc flash and electric shock hazard. Open all local and remote electric power disconnect switches, verify with a voltmeter that power is Off and wear personal protective equipment per NFPA 70E before working within the electric control enclosure. Failure to comply can cause serious injury or death.

Customer must provide earth ground to unit, per NEC, CEC and local codes, as applicable.

Before proceeding with installation, read all instructions, verify that all the parts are included and check the nameplate to be sure the voltage matches available utility power.

The factory-supplied disconnect switch is inside the electric control enclosure. The line side of this switch contains live high-voltage.

The only way to ensure that there is NO voltage inside the unit is to install and open a remote disconnect switch. Refer to unit electrical schematic.

Follow all local codes.

WARNING

Risk of contact with high-speed, rotating fan blades. Can cause serious injury or death.

Fan blades can automatically start rotating without warning at any time during a cooling cycle or after power is restored after a power failure. Open all local and remote electric power supply disconnect switches, wait 10 minutes and verify with a voltmeter that power is Off before working within the unit cabinet, removing the fan guards or servicing the fan speed control, fan blades or fan motors.



NOTE

Installation and service of this equipment should be performed only by properly-trained and qualified personnel who have been specially-trained in the installation of air-conditioning equipment.



NOTE

Use copper wiring only. Make sure that all connections are tight.

Each unit is shipped from the factory with all internal unit wiring completed. Refer to the electrical schematic supplied with the condenser when making line voltage supply, low voltage indoor unit interlock and any low voltage alarm connections. All wiring must be done in accordance with all applicable local, state and national electrical codes.

Table 5-1 60Hz condenser data

Model #	083, 104, 28K			165, 205, 60K			251, 308, 90K			415, 510			616			830, 1010			
# of Fans	1			2			3			4			6			8			
Input Voltage	ph	FLA	WSA	OPD	FLA	WSA	OPD	FLA	WSA	OPD	FLA	WSA	OPD	FLA	WSA	OPD	FLA	WSA	OPD
Fan Speed Controlled																			
208/230	1	4.8	6.0	15	—	—	—	—	—	—	—	—	—	—	—	—	—	—	—
460		2.5	3.1	15	—	—	—	—	—	—	—	—	—	—	—	—	—	—	—
575		1.9	2.4	15	—	—	—	—	—	—	—	—	—	—	—	—	—	—	—
208/230	3	—	—	—	8.3	9.5	15	11.8	13.0	15	15.3	16.5	20	23.6	24.8	30	30.6	31.8	40
460		—	—	—	4.2	4.8	15	5.9	6.5	15	7.6	8.2	15	11.8	12.4	15	15.2	15.8	20
575		—	—	—	3.3	3.8	15	4.7	5.2	15	6.1	6.6	15	9.4	9.9	15	12.2	12.7	15
VFD Controlled¹																			
208/230	3	3.7	4.6	15	7.2	8.1	15	10.7	11.6	15	14.2	15.1	20	N/A	N/A	N/A	N/A	N/A	N/A
460		1.8	2.3	15	3.5	4.0	15	5.2	5.7	15	6.9	7.4	15	N/A	N/A	N/A	N/A	N/A	N/A
Liebert Lee-Temp Controlled/Fan-Cycling																			
208/230	3	3.5	4.4	15	7.0	7.9	15	10.5	11.4	15	14.0	14.9	20	21.0	21.9	25	28.0	28.9	35
460		1.7	2.1	15	3.4	3.8	15	5.1	5.5	15	6.8	7.2	15	10.2	10.6	15	13.6	14.0	20
575		1.4	1.8	15	2.8	3.2	15	4.2	4.6	15	5.6	6.0	15	8.4	8.8	15	11.2	11.6	15

FLA = Full Load Amps; WSA = Wire Size Amps; OPD = Maximum Overcurrent Protection Device

¹When Low-Ambient VFD Heater Kit is installed, increase condenser WSA by 1.0 A for 208 V, 1.1 A for 230 V and 0.5 A for 460 V.

Table 5-2 60Hz condenser data, Liebert Quiet-Line (Liebert Lee-Temp controlled/fan-cycling)

Model #	063			119, 127, 143			214			286			409			572			
# of Fans	1			2			3			4			6			8			
Input Voltage	ph	FLA	WSA	OPD	FLA	WSA	OPD	FLA	WSA	OPD	FLA	WSA	OPD	FLA	WSA	OPD	FLA	WSA	OPD
208/230	3	1.8	2.3	15	3.6	4.1	15	5.4	5.9	15	7.2	7.7	15	10.8	11.3	15	14.4	14.9	20
460		0.9	1.1	15	1.8	2.0	15	2.7	2.9	15	3.6	3.8	15	5.4	5.6	15	7.2	7.4	15
575		0.7	0.9	15	1.4	1.6	15	2.1	2.3	15	2.8	3.0	15	4.2	4.4	15	5.6	5.8	15

FLA = Full Load Amps; WSA = Wire Size Amps; OPD = Maximum Overcurrent Protection Device

Table 5-3 50Hz condenser full load amp values

Condenser Control Type		Fan Speed Controlled		VFD Controlled		Lee Temp Controlled/Fan-Cycling		Liebert Quiet-Line (Liebert Lee Temp Controlled/Fan-Cycling)		
Model #	# of Fans	Input Voltage - Phase		Input Voltage - Phase		Input Voltage - Phase		Model #	Input Voltage - Phase	
		200/220-1	380/415-3	200/230-3	380/415-3	200/230-3	380/415-3		200/230-3	380/415-3
083, 104	1	4.0	-	3.7	1.8	3.5	1.7	063	1.8	0.9
165, 205	2	—	3.7	7.2	3.5	7.0	3.4	119, 127, 143	3.6	1.8
251, 308	3	—	5.4	10.7	5.2	10.5	5.1	214	5.4	2.7
415, 510	4	—	7.1	14.2	6.9	14.0	6.8	286	7.2	3.6
616	6	—	10.8	—	—	21.0	10.2	409	10.8	5.4
830, 1010	8	—	14.2	—	—	28.0	13.6	572	14.4	7.2

Table 5-4 Liebert Lee-Temp receiver electrical data, 50Hz and 60Hz

Rated Voltage - Single Phase	120			200/208/230		
	Watts/Receiver	150	300	450	150	300
Full Load Amps	1.4	2.8	4.2	0.7	1.4	2.1
Wire Size Amps	1.8	3.5	5.3	0.9	1.8	2.7
Maximum Overcurrent Protection Device, Amps	15	15	15	15	15	15

The Liebert Lee-Temp receiver requires a separate power feed for heaters. The condenser is not designed to supply power to the receiver.

5.1.1 Line Voltage Wiring



WARNING

Risk of improper wire sizing. Can cause short circuit, overheated wire, smoke, fire, building and equipment damage, injury or death.

Select and install the electrical supply wire and overcurrent protection device(s) according to the specifications on the unit nameplate(s), per the instructions in this manual and according to the applicable national, state and local code requirements. Use copper conductors only. Make sure all electrical connections are tight. Unit-specific wiring diagrams are provided on each unit.

Condenser-rated voltage should be verified with available power supply before installation. Refer to the unit's electrical schematic and serial tag for specific electrical requirements.

Line voltage electrical service is required for all condensers at the location of the condenser. The power supply does not necessarily have to be the same voltage supply as required by the indoor unit connected to the condenser. See the unit's serial tag for specific condenser electrical requirements. A unit disconnect is standard on VFD and Liebert Quiet-Line Condensers and is optional on Fan Speed Control and standard Liebert Lee-Temp condensers. However, a site disconnect may be required per local code to isolate the unit for maintenance. Route the supply power to the site disconnect switch and then to the unit. Route the conduit through the hole provided in the cabinet. Connect earth ground to lug provided near terminal board.



NOTE

*Liebert Lee-Temp and Liebert Quiet-Line Condensers require a separate line voltage electrical supply for the heated receivers. See **Table 5-4** for power requirements.*

5.1.1.1 Line Voltage —VFD-Control Condensers Only

The installer/startup technician must determine the type of 3-phase supply power being used for the VFD Control Condenser: Wye-connected power or Delta-connected power.

Wye-connected power has two different voltages that can be measured: Phase-to-Phase voltage (this is equal to the nominal input voltage) and Phase-to-Neutral voltage (typically used for small single phase loads (120VAC or 277VAC). See **Figure 5-1**.

Delta-connected power only has one voltage level that can be measured: Phase-to-Phase. See **Figure 5-2**.



WARNING

Risk of electric shock. Can cause injury or death.

The optional, variable-frequency fan-speed control may contain a stored electrical charge. Open all local and remote electric power disconnect switches, verify with a voltmeter that power is Off and wait 10 minutes before working within the optional, variable-frequency fan-speed control electrical enclosures.

Wye-Connected Power Supply

No control changes are required if the Liebert VFD Control Condenser will be operated with Wye-connected power.

Figure 5-1 Wye-connected power diagram

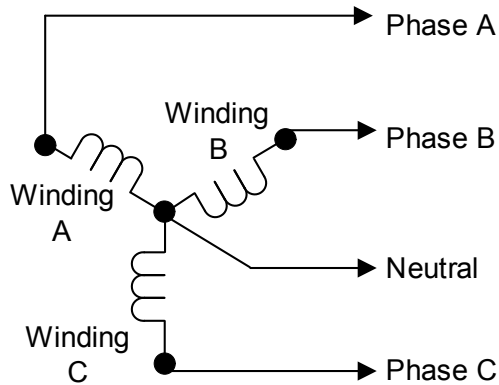

Delta-Connected Power Supply

Figure 5-2 Delta-connected power diagram

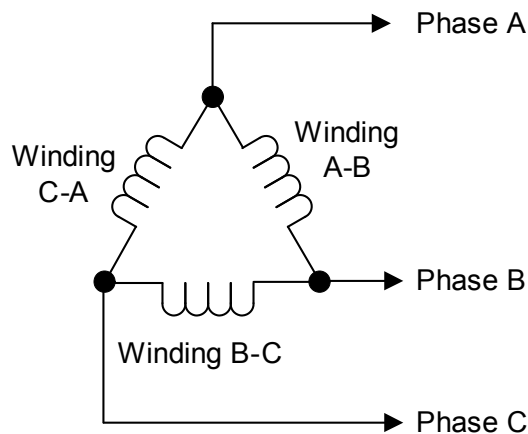

5.1.1.2 Disconnect EMC Filter for Delta-Connected Power

Installer/startup technician needs to disconnect the EMC filter on the VFD to ensure proper operation if the Liebert VFD Control Condenser will be operated with Delta-connected power.

1. Disconnect the power supply before working on the unit.
2. Open the electrical panel cover and locate the VFD (Refer to **Figure 5-5**).

3. Using **Figure 5-3**, remove the terminal cover from the VFD control:
 - Using a flat-bladed screwdriver, turn the terminal-cover locking clip counterclockwise approximately 30°
 - Slide the terminal cover down and remove it.
 - Remove the screw labeled EMC to disconnect the internal EMC filter.

Figure 5-3 Disconnecting EMC filter for operation with Delta-connected power

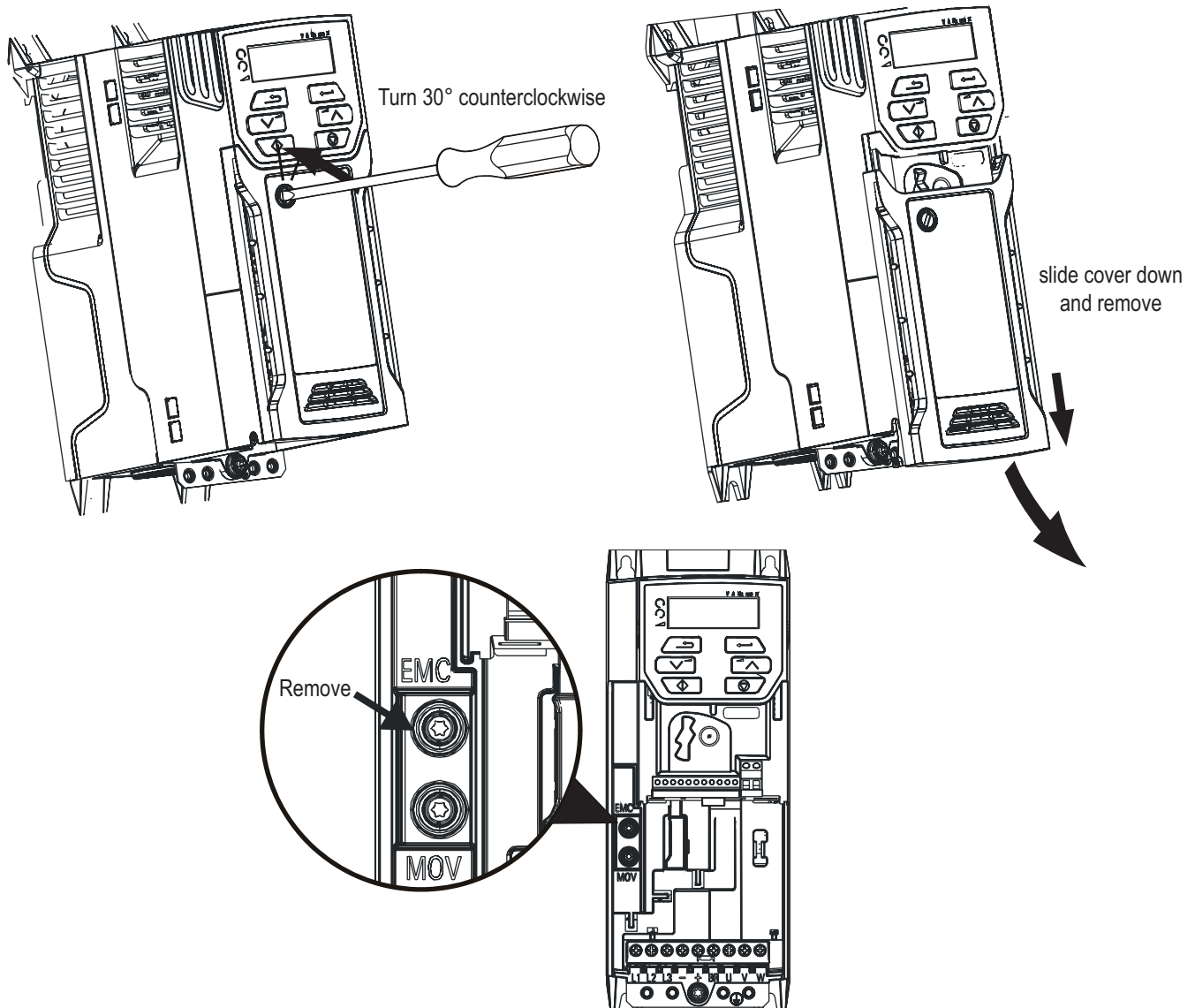

5.1.1.3 Surge Protection Device—VFD-control Condensers Only

A Surge Protective Device (SPD) panel is standard in the VFD Condenser models only. Surge protection is necessary because the rooftop voltage supply often is not conditioned the same as the voltage supply inside the data center. The SPD is designed to protect the VFD from high voltage transients, up to 25kVA/phase.

An illuminated green LED indicates power supply is On and panel status is OK. An illuminated red LED indicates conditions require service and the SPD may require replacement to restore surge protection to the condenser.

5.1.2 Low Voltage Control Wiring

NOTICE

Risk of control malfunction. Can cause improper unit operation. Make sure that all low voltage electrical wiring has been performed per the schematic diagram provided and that all low voltage wiring connections are tight.

A control interlock between the condenser and the indoor cooling units is required. Field-supplied copper wire is required for connection between like-numbered terminals 70 & 71 on both units. Wiring must be sized and selected for insulation case per NEC and other local codes. See **Tables 5-5** and **5-6** for recommended wire sizing for control wiring runs up to 150 ft (45.7m). Contact the factory for assistance with longer wiring runs. See **Figures 5-4, 5-5** and **5-6** and indoor unit manual for location of terminals on condensers and indoor units.

Table 5-5 Minimum recommended control circuit wire size, AWG, 60Hz models

Control Wire Run ft (m)	Control Type												
	VFD & Fan Speed Controlled						Liebert Lee-Temp Only		Liebert Lee-Temp Controlled with Fan-Cycling				
	Number of Fans						Number of Fans		Number of Fans				
	1	2	3	4	6	8	1-4	6 & 8	2	3	4	6	8
0-25 (0-7.6)	16	16	16	16	16	16	16	16	16	16	16	16	16
26-50 (7.9-15.2)			16	16	14	16				16	16	16	
51-75 (15.5-22.8)			16	16	14	14				16	16	16	16
76-100 (23.2-30.4)			16	16	12	12				16	16	16	16
101-125 (30.8-38.1)			16	14	10	12				16	14	16	14
126-150 (38.4-45.7)			14	14	10	10				14	14	14	14

Table based on 16AWG min. wire size, 0.4A per contactor, 1 to 1.5V maximum drop & 104°F (40°C) average ambient temperature

Table 5-6 Minimum recommended control circuit wire size, mm², 50 Hz models

Control Wire Run, M (ft)	Control Type												
	VFD & Fan Speed Controlled						Liebert Lee-Temp Only		Liebert Lee-Temp Controlled with Fan-Cycling				
	Number of Fans						Number of Fans		Number of Fans				
	1	2	3	4	6	8	1-4	6 & 8	2	3	4	6	8
0-7.6 (0-25)	1.0	1.0	1.0	1.0	1.5	1.0	1.0	1.0	1.0	1.0	1.0	1.0	1.0
7.9-15.2 (26-50)			1.0	1.0	2.5	2.5		1.0	1.0	1.0	1.0	1.0	
15.5-22.8 (51-75)			1.5	1.5	4.0	4.0		1.0	1.0	1.5	1.5	1.5	1.5
23.2-30.4 (76-100)			1.5	2.5	6.0	4.0		1.0	1.0	1.5	2.5	1.5	2.5
30.8-38.1 (101-125)			2.5	2.5	6.0	6.0		1.5	1.5	2.5	2.5	2.5	2.5
38.4-45.7 (126-150)			2.5	4.0	6.0	6.0		1.5	1.5	2.5	4.0	2.5	4.0

Table based on 1.0mm² min. wire size, 0.5A per contactor, 1 to 1.5V maximum drop & 40 °C (104 °F) average ambient temperature

5.1.2.1 Low Voltage Monitoring Wiring—VFD Condensers Only

Condensers with monitoring terminals may be wired with Class 1 copper wire to the indoor cooling unit or other monitoring panel. Wiring must be sized so that the voltage drop in the circuit does not exceed 1 volt. Dry contacts close when a monitored event occurs. Consult condenser electrical schematic, supplied with the unit, for details.

Contact closure on VFD Drive monitoring terminals indicates a healthy VFD drive. Contact open indicates no power to condenser or a permanent VFD fault. A factory-programmed VFD must be used as the replacement.

Contact closure on SPD monitoring terminals may indicate unit trouble ranging from electrical supply issues to SPD replacement required. A properly trained and qualified electrician is required.

5.2 Electrical field connection descriptions

Figure 5-4 Electrical field connections for Fan Speed Control Condensers

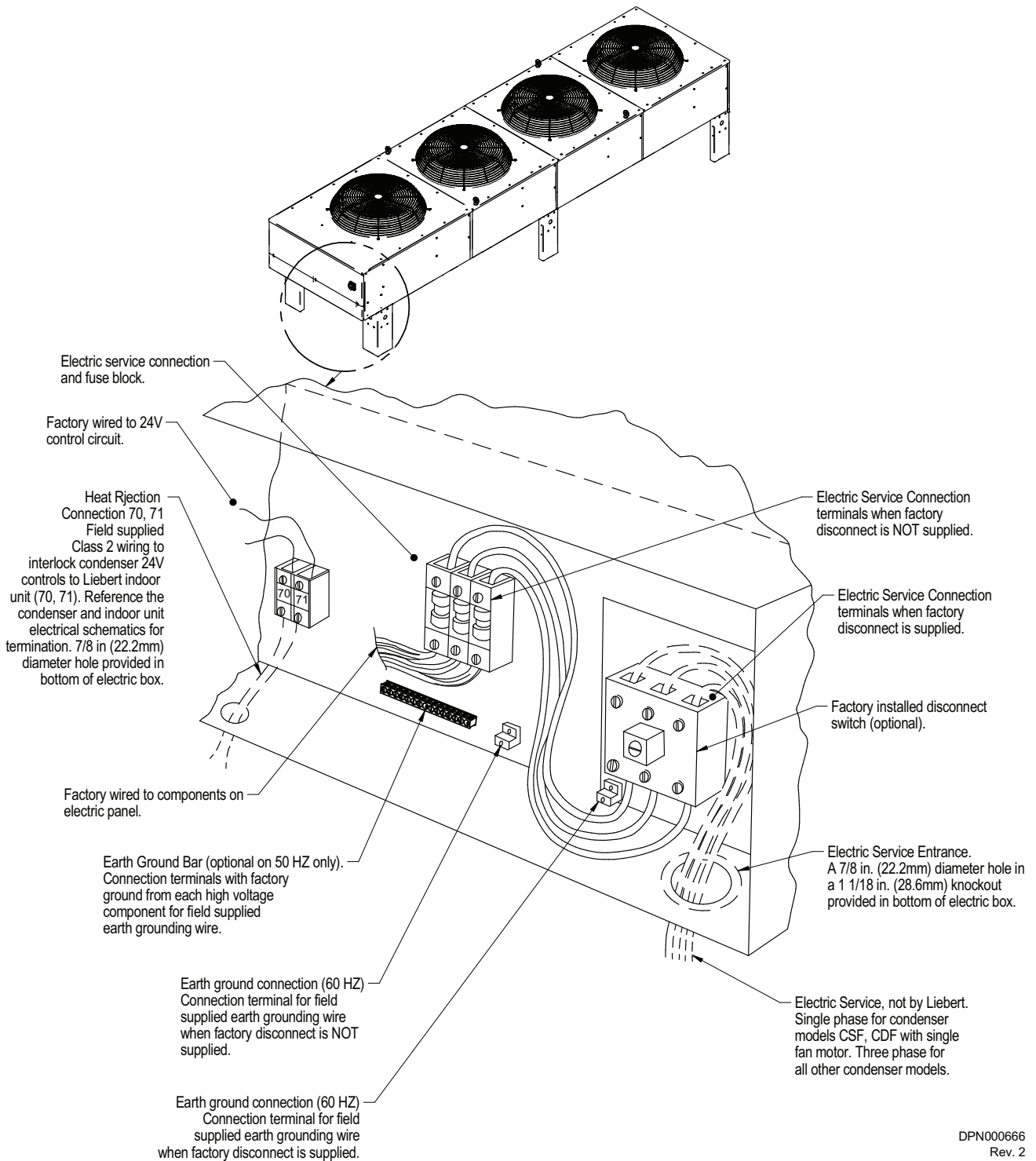

DPN000666
Rev. 2

Figure 5-5 Electrical field connections for VFD control condensers

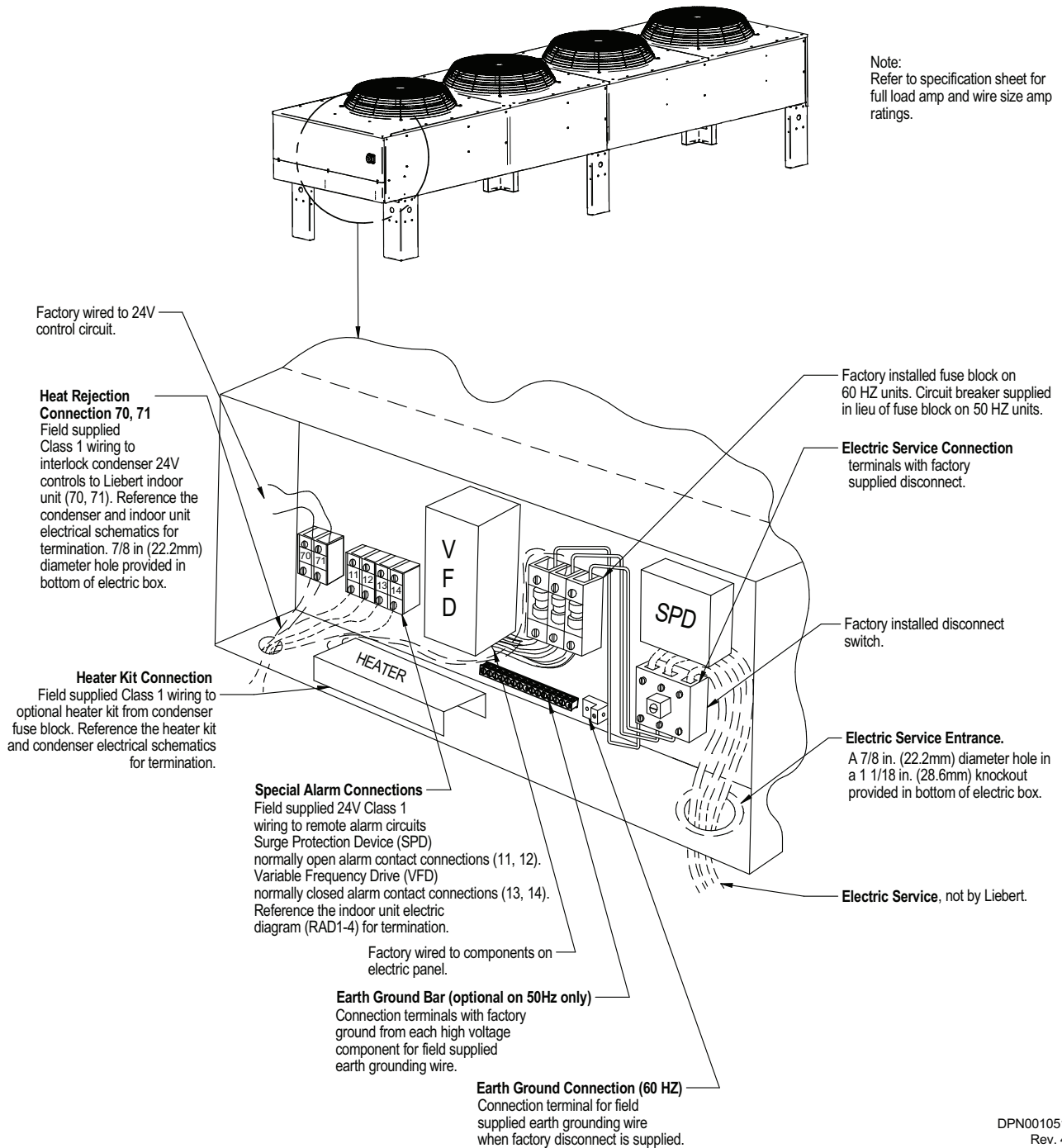

DPN001051
Rev. 4

Figure 5-6 Electrical field connections for Liebert Lee-Temp control condensers

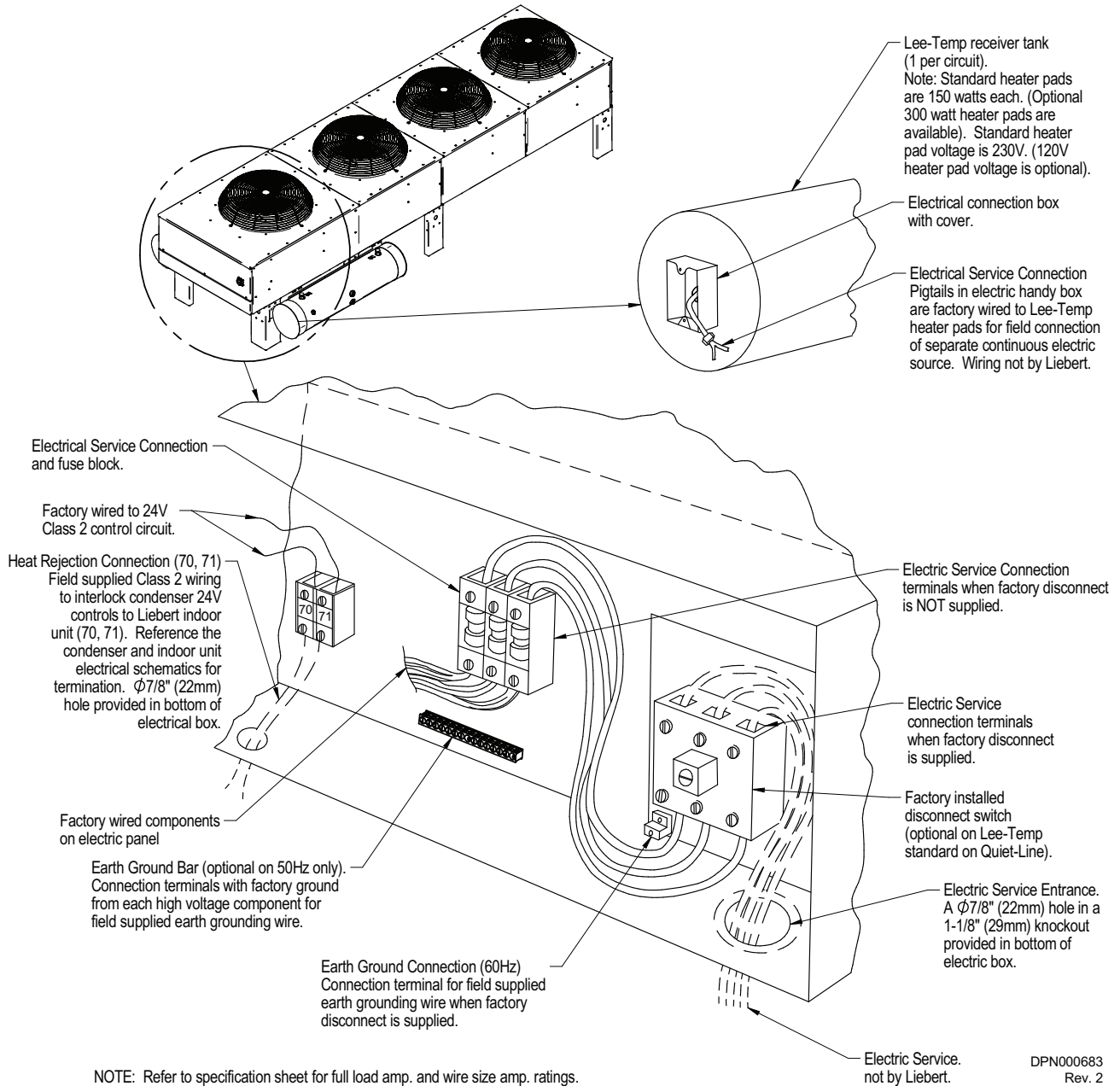

DPN000683
Rev. 2

6.0 Checklist for Completed Installation

6.1 Moving and Placing Equipment

- 1. Unpack and check received material
- 2. Proper clearance for service access has been maintained around the equipment
- 3. Equipment is level and mounting fasteners are tight

6.2 Electrical

- 1. Line voltage connected and matches equipment nameplate
- 2. Power line circuit breakers or fuses have proper ratings for equipment installed
- 3. Control wiring connections completed between indoor cooling unit and condenser
- 4. All internal and external high and low voltage wiring connections are tight
- 5. VFD condensers only—Check for Delta-Connected Power Supply and make any needed adjustments per **5.1.1.2 - Disconnect EMC Filter for Delta-Connected Power**
- 6. Monitoring wiring connections completed, when equipped, to indoor cooling unit or external monitoring panel
- 7. Confirm that unit is properly grounded to an earth ground
- 8. Control transformer setting matches incoming power
- 9. Electrical service conforms to national and local codes
- 10. Check fans for proper phase rotation. Blades should rotate clockwise when viewing the unit from the fan guard side.

6.3 Piping

- 1. Piping is completed to corresponding indoor cooling unit refrigeration circuit.
- 2. Piping leak-checked, evacuated and charged with specified refrigerant.
- 3. Additional refrigerant oil added, if required, per circuit.
- 4. Piping is properly sized, sloped and trapped for proper oil return.
- 5. Piping is routed to reduce potential of rub-through or chaffing.
- 6. Refrigerant lines are secured to condenser leg(s).

6.4 Other

- 1. Fans rotate freely and in proper direction
- 2. Adjust ambient thermostat setpoints to match setpoints on the electrical schematic supplied with the condenser.
- 3. Foreign material removed from in and around all equipment installed (construction materials, construction debris, etc.).
- 4. Installation materials and tools have been removed from in and around all equipment (literature, shipping materials, tools, etc.).
- 5. Blank start-up sheet located, ready for completion by installer or start-up technician.

Page intentionally left blank.

7.0 Operation

WARNING

Arc flash and electric shock hazard. Open all local and remote electric power disconnect switches, verify with a voltmeter that power is Off and wear personal protective equipment per NFPA 70E before working within the electric control enclosure. Failure to comply can cause serious injury or death.

Customer must provide earth ground to unit, per NEC, CEC and local codes, as applicable.

Before proceeding with installation, read all instructions, verify that all the parts are included and check the nameplate to be sure the voltage matches available utility power.

The factory-supplied disconnect switch is inside the electric control enclosure. The line side of this switch contains live high-voltage.

The only way to ensure that there is NO voltage inside the unit is to install and open a remote disconnect switch. Refer to unit electrical schematic.

Follow all local codes.

7.1 Startup Checklist

Refer to **6.0 - Checklist for Completed Installation** and verify that all installation items have been completed before beginning to start the condenser.

7.2 Startup

- Locate “Liebert Fin/Tube Condenser Warranty Inspection Check Sheet” (Document # PSWI-8542-407CO).
- Turn the condenser disconnect ON. Indoor units should be turned on and set for cooling to allow operation of condenser.
- Check the fans for proper rotation: Clockwise when viewing the unit from the fan guard (top) side. Check that air is being drawn through the coil and discharged out the fan assembly. Some ambient thermostats may need to be temporarily adjusted to lower temperature settings to observe all fans operate. Readjust thermostat settings to correspond to setpoints shown on the electrical schematic supplied with the unit.
- Complete “Liebert Fin/Tube Condenser Warranty Inspection Check Sheet” (Document # PSWI-8542-407CO).



NOTE

This document must be completed and forwarded to your local Emerson sales office to validate warranty.

- Contact your local Emerson sales representative or Liebert Thermal Management Support if you have any questions or problems during unit startup and commissioning.
- Local Emerson sales offices and Liebert Thermal Management Support contacts can be found at www.liebert.com/servicesupport_pages/ServiceSupport.aspx?x=servicesupport or by calling 1-800-LIEBERT.

Page intentionally left blank.

8.0 Troubleshooting

Table 8-1 Troubleshooting

Symptom	Possible Cause	Check or Remedy
Condenser will not start	No power to condenser	Check voltage at input terminal block
	Circuit breaker for low voltage transformer in condenser is tripped	Locate problem in condenser electrical panel and repair
	No low voltage signal to/from indoor unit	Locate open circuit and repair
Low indoor unit suction pressure	Insufficient refrigerant in system	Check for leaks, repair, and add refrigerant
	Fan-cycling ambient thermostats setpoints too low	Check schematic for recommended setpoints and adjust.
Low discharge pressure	Faulty head pressure control valve or condenser FSC/VFD control	Replace if defective
High discharge pressure	Dirty condenser fins	Clean coil
	Condenser fans not operating	Check for low voltage signal from indoor unit
		Check fan motors and fuses
		Check for correct ambient thermostat setpoints, as applicable.
High refrigerant charge	Check refrigerant charge	
VFD Condenser trips out on over voltage (OU displayed on VFD controller)	Supply voltage is Delta configuration or is ungrounded/high impedance	Shut off AC voltage, locate the VFD, pull out the EMC tab and reconnect power
SPD indicator lights are extinguished or red LED is illuminated and monitoring terminals 11/12 are closed	No voltage or improper phasing exists at condenser	Check voltage at input terminal block
	Electrical connections to SPD are faulty	Locate connection problem and repair
	A surge exceeding the rating of the SPD has occurred	Replace SPD and inspect other components for damage and replace them if necessary

Page intentionally left blank.

9.0 System Maintenance



WARNING

Arc flash and electric shock hazard. Open all local and remote electric power disconnect switches, verify with a voltmeter that power is Off and wear personal protective equipment per NFPA 70E before working within the electric control enclosure. Failure to comply can cause serious injury or death.

Customer must provide earth ground to unit, per NEC, CEC and local codes, as applicable.

Before proceeding with installation, read all instructions, verify that all the parts are included and check the nameplate to be sure the voltage matches available utility power.

The factory-supplied disconnect switch is inside the electric control enclosure. The line side of this switch contains live high-voltage.

The only way to ensure that there is NO voltage inside the unit is to install and open a remote disconnect switch. Refer to unit electrical schematic.

Follow all local codes.

9.1 General Procedures



NOTE

When ordering replacement parts for equipment, it is necessary to specify unit model number, serial number, and voltage. Please record those numbers in the spaces below.

- Model Number _____
- Serial Number _____
- Voltage/Phase/Frequency _____

Periodic attention is necessary for continued satisfactory operation of your unit. Restricted air flow through the condenser coil, reduced airflow from non-functioning fans and low refrigerant system charge levels will reduce the operating efficiency of the unit and can result in high condensing temperatures and loss of cooling. In winter, do not permit snow to accumulate around the sides or underneath the condenser coil.

Monthly and semi-annual inspections and maintenance are recommended for proper system operation. Use copies of **10.0 - Preventive Maintenance Checklist** for each of these inspections.

If performance or operation problems are detected at anytime, refer to **8.0 - Troubleshooting** for required action.

9.2 Special Procedures

9.2.1 Condenser Cleaning

Keeping the outdoor condenser coils clean is an important factor in maintaining peak efficiency, reliability and long life of the equipment. It is much easier to keep up on frequent cleanings rather than wait until heavy build up has occurred which may create head pressure problems with the evaporator units.

When to Clean

Normal conditions typically dictate cleaning twice a year, spring and fall. On-site or area conditions such as cottonwood trees, construction, etc., can increase cleaning frequency. On your standard monthly preventive maintenance schedule, a visual inspection of the coil is recommended to monitor conditions.

What to Use

The best overall condenser coil cleaner to use is plain water. If the coil has been maintained and cleaned at regular intervals, water is sufficient to remove dirt and debris from the fins. Heavy build up on the exterior of the fins can be removed with a brush. Water pressure from a garden hose and sprayer usually works well. If a pressure washer is used, make sure the equipment is set to a lower pressure setting and that the nozzle is set to the fan spray, not stream. Otherwise, damage to the fins could result. If a cleaner is required, we recommend a non-acidic type cleaner be used. Acid-type cleaners can be aggressive to the coil fins as well as surrounding areas. Many sites do not allow the use of acidic cleaners for environmental reasons.

How to Clean

The absolute best way to clean coils is from the inside out. This requires disconnecting the power supply from the condenser before working on the unit. The fan guards and fan blades must be removed to gain access to the coil surface. The sprayer can then be worked across the coil using the water/cleaning solution, pushing the dirt and debris out the bottom of the coil. Although this does extend the time involved, the results are well worth it. This method should be used at least once a year. Spraying the coil from the outside repeatedly can push a majority of the dirt to the inner section of the fins and continue to restrict air flow. Keep in mind you may not have the luxury of shutting the unit(s) down for an extended time. A pre-scheduled shutdown with the operator may be in order. If you are using a cleaner along with the spraying process, follow recommended manufacturer instructions and be sure to rinse the coil thoroughly. Any residue left on the coil can act as a magnet to dirt.

Reinstall and secure the fan blades and fan guards after the cleaning is finished. Last, reconnect the power supply to the condenser.

10.0 Preventive Maintenance Checklist

Source: DPN003119, Rev. 0

Inspection Date	_____	Job Name	_____
Indoor Unit Model #	_____	Indoor Unit Serial Number #	_____
Condenser #	_____	Condenser Serial #	_____
Room Temperature/Humidity	_____ ° _____ %	Ambient Temperature	_____ °

Good maintenance practices are essential to minimizing operation cost and maximizing product life. Read and follow all applicable maintenance checks listed below. At a minimum, these checks should be performed semi-annually. However, maintenance intervals may need to be more frequent based on site-specific conditions. Review the unit user manual for further information on unit operation. Emerson recommends the use of trained and authorized service personnel, extended service contracts, and factory-certified replacement parts. Contact your local Emerson Representative for more details.

Check all that apply:

Air-Cooled Fin/Tube Condenser

- 1. Coil clean and free of debris
- 2. Motor mounts tight
- 3. Piping support/clamps secure
- 4. Check/Re-torque wire connections
- 5. Check contactors for pitting (replace if pitted)
- 6. Check fuses
- 7. Verify fan operation
- 8. Check surge-protection device status-indicator lights (if equipped)
- 9. Ambient thermostat settings _____
- 10. Refrigerant level (Lee-Temp™)
- 11. Check refrigerant lines for signs of leaks/repair as found
- 12. Motor amp draw

#1	L1	_____	L2	_____	L3	_____
#2	L1	_____	L2	_____	L3	_____
#3	L1	_____	L2	_____	L3	_____
#4	L1	_____	L2	_____	L3	_____
#5	L1	_____	L2	_____	L3	_____
#6	L1	_____	L2	_____	L3	_____
#7	L1	_____	L2	_____	L3	_____
#8	L1	_____	L2	_____	L3	_____

Technical Support / Service

Web Site

www.liebert.com

Monitoring

liebert.monitoring@emerson.com

800-222-5877

Outside North America: +00800 1155 4499

Single-Phase UPS & Server Cabinets

liebert.upstech@emerson.com

800-222-5877

Outside North America: +00800 1155 4499

Three-Phase UPS & Power Systems

800-543-2378

Outside North America: 614-841-6598

Thermal Management Systems

800-543-2778

Outside the United States: 614-888-0246

Locations

United States

1050 Dearborn Drive

P.O. Box 29186

Columbus, OH 43229

Europe

Via Leonardo Da Vinci 8

Zona Industriale Tognana

35028 Piove Di Sacco (PD) Italy

+39 049 9719 111

Fax: +39 049 5841 257

Asia

7/F, Dah Sing Financial Centre

108 Gloucester Road, Wanchai

Hong Kong

852 2572220

Fax: 852 28029250

While every precaution has been taken to ensure the accuracy and completeness of this literature, Liebert Corporation assumes no responsibility and disclaims all liability for damages resulting from use of this information or for any errors or omissions.

© 2016 Liebert Corporation

All rights reserved throughout the world.

Specifications subject to change without notice.

® Liebert is a registered trademark of Liebert Corporation. All names referred to are trademarks or registered trademarks of their respective owners.

SL-10066_REV5_5-16

590-1315-501A

Emerson Network Power

www.emersonnetworkpower.com