

Liebert® Challenger™ 3000 with Liebert iCOM®

Technical Data Manual - Floor Mounted Systems, Nominal 3 & 5 Ton Systems,
Air-Cooled, Water/Glycol-Cooled, GLYCOOL, Chilled Water, Split Systems, 50 & 60 Hz



PRODUCT NOMENCLATURE

Figure i Product model information

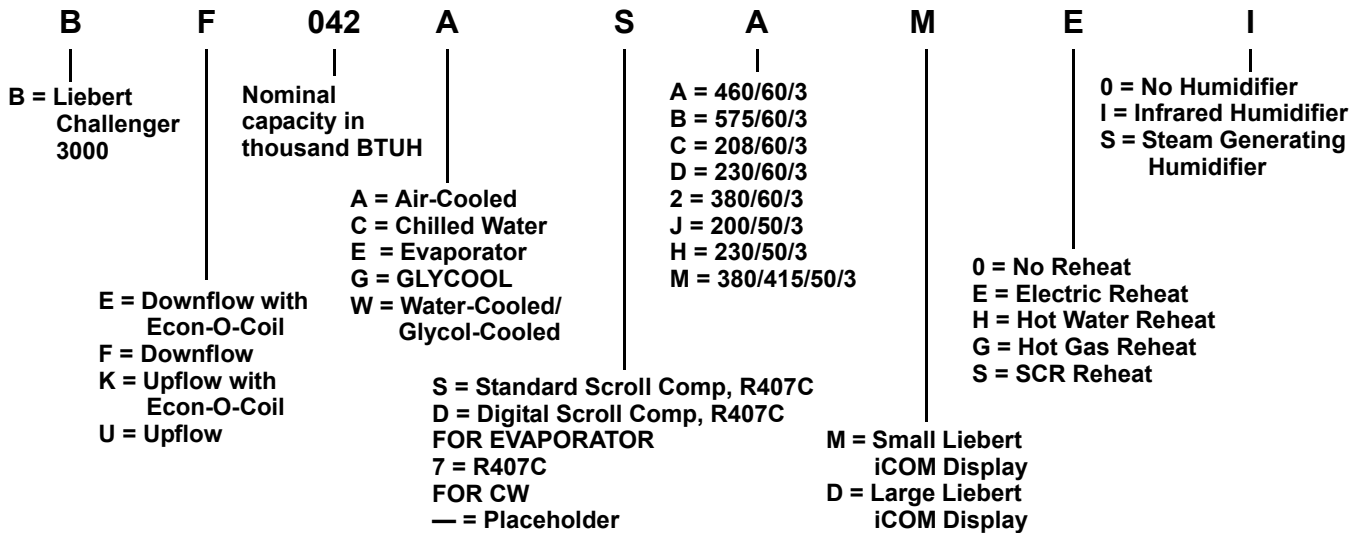

NOTE

Figure i and Tables i and ii show nomenclature for the complete range of all available product options. Not all combinations are possible. For assistance, contact your local dealer, Liebert representative or call 1-800-543-2778.

Table i Split system configurations

Capacity	Evaporator		Standard Condensing Units		
			Air Cooled Prop Fan Condensing Unit	Air Cooled Centrifugal Condensing Unit	Water/Glycol Condensing Unit
3 Tons	60 Hz (50 Hz)	B*036E (B*035E)	PFH_42A (PFH_41A)	MC_40A (MC_39A)	MC_44W (MC_43W)
5 Tons	60 Hz (50 Hz)	B*060E (B*059E)	PFH_67A (PFH_66A)	MC_65A (MC_64A)	MC_69W (MC_68W)

* F = Downflow U = Upflow

Table ii Self-contained system configurations

Capacity	Indoor Unit	Remote Equipment		System Type
		Air Cooled Condenser	Drycooler/Pump	
3 Ton	60Hz (50Hz)	B*042A (B*040A)	@083 ^028	Air Cooled
	60Hz (50Hz)	B*046WG (B*045WG)	—	DSF092-6 1.5hp Pump 1.5hp Pump 50Hz
	60Hz (50Hz)	B*068C (B*072C)	—	—
5 Ton	60Hz (50Hz)	B*067A (B*065A)	@104 ^028	Air-Cooled
	60Hz (50Hz)	B*071WG (B*070WG)	—	DSF109 - 8 2hp Pump 60Hz 2hp Pump 50Hz
	60Hz (50Hz)	B#061G (B#058G)	—	DSO109 - 8 3hp Pump 60Hz 3hp Pump 50Hz
	60Hz (50Hz)	B*102C (B*101C)	—	—

* F = Downflow U = Upflow # E = Downflow K = Upflow @ CSF = Fan Speed Control CSL = Liebert Lee-Temp TCSV = VFD Control ^ = MCS

TABLE OF CONTENTS

PRODUCT NOMENCLATURE	INSIDE FRONT COVER
1.0 PRECISION ENVIRONMENTAL CONTROL FOR INDUSTRIAL, TELECOMMUNICATIONS, MEDICAL AND DATA PROCESSING EQUIPMENT	1
1.1 Liebert Challenger 3000	1
1.2 Agency Listed	1
2.0 STANDARD FEATURES—ALL SYSTEMS	4
2.1 Cabinet and Frame	4
2.2 Electrical Panel	4
2.3 Fan Section	4
2.4 Infrared Humidifier	4
2.5 Electric Reheat	4
2.6 Filters	4
2.7 Liebert iCOM [®] Control	5
3.0 CHILLED WATER SYSTEM—STANDARD & OPTIONAL FEATURES	6
3.1 Chilled Water System—Standard Features	6
3.1.1 Cooling Coil	6
3.1.2 Modulating Motor	6
3.1.3 Three-Way Control Valve	6
3.1.4 Line Insulation	6
3.2 Chilled Water System—Optional Features	6
3.2.1 Two-Way Control Valve	6
3.2.2 Chilled Water Flow Switch	6
3.2.3 Hot Water Reheat—Chilled Water Units Only	6
3.2.4 High Pressure	6
4.0 REFRIGERATION SYSTEMS—STANDARD AND OPTIONAL FEATURES	8
4.1 Refrigeration System Components—Standard Features	8
4.1.1 Compressor	8
4.1.2 Evaporator Coil	8
4.1.3 Safety Control	8
4.1.4 Expansion Valve	8
4.1.5 Refrigerant	8
4.2 Refrigeration System Components—Optional Features	8
4.2.1 Digital Scroll Compressor	8
5.0 AIR-COOLED SYSTEM—STANDARD AND OPTIONAL FEATURES	9
5.1 Air-Cooled, Self-Contained Systems—Standard Features	9
5.1.1 Crankcase Heater and Discharge Check Valves	9
5.1.2 Condenser	9
5.2 Condenser Types	9
5.2.1 Liebert MC [™] Condenser	9
5.2.2 Liebert Fin/Tube Condenser	10

5.3	Air-Cooled Split Systems—Standard Features	11
5.3.1	Centrifugal Fan, Indoor Condensing Unit	11
5.3.2	Propeller Fan, Outdoor Condensing Unit	11
5.4	Air-Cooled Split Systems—Optional Features	12
5.4.1	Non-Fused Disconnect Switch	12
5.4.2	Pre-Charged Line Sets	12
5.4.3	Refrigerant-Line Sweat Adapter Kit	12
6.0	WATER/GLYCOL-COOLED SYSTEMS—STANDARD AND OPTIONAL FEATURES	13
6.1	Water/Glycol Self-Contained Systems—Standard Features	13
6.1.1	Liquid-Cooled Condensers	13
6.1.2	Regulating Valves—Non-Digital Scroll Compressor Models Only	13
6.2	Water/Glycol-Cooled, Self-Contained System—Optional Features	13
6.2.1	Three-way Regulating Valves	13
6.2.2	High Pressure	13
6.2.3	Motorized Ball Valve—Digital Scroll Compressor Models Only	13
6.2.4	Compressor Crankcase Heater	13
6.2.5	Hot Gas Reheat	13
6.3	Water/Glycol Split System—Standard Features	14
6.3.1	Water/Glycol-Cooled, Indoor Condensing Units	14
6.4	Water/Glycol-Cooled, Split System—Optional Features	14
6.4.1	High Pressure	14
6.4.2	Factory-Installed Non-Fused Disconnect Switch	14
6.4.3	Pre-Charged Line Sets—3 Ton Only	14
6.4.4	Refrigerant-Line Sweat Adapter Kit	14
6.5	Glycol-Cooled Systems—Standard Heat Rejection Devices for Self-Contained and Split Systems	14
6.5.1	Fan Speed Control Drycooler	14
6.5.2	Glycol Pump Package	14
6.6	Glycol-Cooled Systems—Optional Heat Rejection Devices for Self-Contained and Split Systems	15
6.6.1	Dual Pump Package	15
6.6.2	Liebert Quiet-Line™ Drycoolers	15
7.0	GLYCOOL SYSTEMS—STANDARD AND OPTIONAL FEATURES	16
7.1	GLYCOOL Self-Contained Systems—Standard Features	16
7.1.1	Comparative Temperature Monitor	16
7.1.2	GLYCOOL Coil	16
7.1.3	GLYCOOL Three-Way Control Valve	16
7.1.4	Glycol-Regulating Valve	16
7.2	GLYCOOL Self-Contained System—Standard Heat Rejection Devices	16
7.2.1	Drycooler	16
7.2.2	Glycol Pump Package	16
7.3	GLYCOOL Self-Contained Systems—Optional Features	18
7.3.1	High Pressure	18
7.3.2	Motorized Ball Valve—Digital Scroll Compressor Models Only	18
7.3.3	Compressor Crankcase Heater	18

7.4	GLYCOOL Self-Contained System—Optional Heat Rejection Devices	18
7.4.1	Dual Pump Package	18
7.4.2	Liebert Quiet-Line Drycoolers	18
8.0	OPTIONAL EQUIPMENT—ALL SYSTEMS.	19
8.1	Dual-Float Condensate Pump	19
8.2	Steam Generating Humidifier	19
8.3	Remote Temperature/Humidity Sensors.	19
8.4	Disconnect Switch—Locking Type	19
8.5	Disconnect Switch—Non-Locking	19
8.6	SCR Reheat.	19
8.7	Adjustable Floor Stand	20
8.8	High-Efficiency Filter.	20
8.9	Heavy Gauge Industrial Panels.	20
8.10	High External Static Blowers	20
8.11	High-Efficiency Motors.	20
8.12	Plenums	20
8.13	Smoke Sensor	20
8.14	High Temperature Sensor	20
9.0	COMPREHENSIVE MONITORING DEVICES—OPTIONAL	21
9.1	Enterprise Monitoring Systems.	21
9.2	Network Monitoring Systems	21
9.2.1	Liebert IntelliSlot Unity® Card	21
9.2.2	Liebert SiteScan Interface Card	21
9.2.3	Leak-Detection Solutions	22
10.0	AIR-COOLED DATA—60HZ.	23
11.0	AIR-COOLED DATA—50HZ.	25
12.0	WATER-COOLED DATA—60HZ.	27
13.0	WATER-COOLED DATA—50HZ.	29
14.0	GLYCOL-COOLED DATA—60HZ	31
15.0	GLYCOL-COOLED DATA—50HZ	33
16.0	CHILLED WATER DATA—60HZ.	35
17.0	CHILLED WATER DATA—50HZ.	36
18.0	DIMENSIONAL DRAWINGS	37
19.0	ELECTRICAL DATA—60HZ	46
20.0	ELECTRICAL DATA—50HZ	52
21.0	GUIDE SPECIFICATIONS—NOMINAL 3 OR 5 TON ENVIRONMENTAL CONTROL SYSTEM.	56

FIGURES

Figure 1	System configurations—Chilled water, self-contained	2
Figure 2	System configurations—Water-cooled, self-contained	2
Figure 3	System configurations—Glycol-cooled, self-contained with matching drycooler and pump	2
Figure 4	System configurations—Air-cooled, self-contained with matching condensers	3
Figure 5	System configurations—GLYCOOL-cooled	3
Figure 6	System configurations—Split systems.	3
Figure 7	Upflow GLYCOOL Liebert Challenger 3000 with front return	5
Figure 8	Chilled water Liebert Challenger 3000 downflow with top return	7
Figure 9	Air-cooled condenser with Liebert Lee-Temp	10
Figure 10	Outdoor propeller fan condensing unit	11
Figure 11	Upflow GLYCOOL Liebert Challenger 3000.	17
Figure 12	Liebert Liqui-tect [®] zone and area leak detection	22
Figure 13	Cabinet and floor planning dimensions—Upflow (BU/BK) models	37
Figure 14	Cabinet and floor planning dimensions—Downflow (BF/BE) models	38
Figure 15	Cabinet dimensions - Split system, 3 ton indoor air-cooled condensing unit	39
Figure 16	Cabinet dimensions - Split system, 5 ton indoor air-cooled condensing unit	40
Figure 17	Cabinet dimensions - Split system, indoor 3 ton water/glycol-cooled condensing unit.	41
Figure 18	Cabinet dimensions—Split system, 5-ton water/glycol-cooled condensing unit	41
Figure 19	Cabinet and floor planning dimensions—Split System, propeller fan condensing unit	42
Figure 20	Cabinet and floor planning dimensions—Split system 5 ton outdoor condensing unit, high ambient and Liebert Quiet-Line [™] models	43
Figure 21	Liebert MC [™] condenser planning dimensions—MCS028	43
Figure 22	Cabinet and floor planning dimensions—Self-contained system, air-cooled fin/tube condenser or drycooler	44
Figure 23	Fin/tube condenser and drycooler dimensions, two-fan model.	44
Figure 24	Cabinet and floor planning dimensions—Piggyback condenser.	45

TABLES

Table 1	Condensate pump capacity	19
Table 2	Liebert Challenger 3000 air-cooled data—60Hz	23
Table 3	Air-cooled data—50Hz	25
Table 4	Water-cooled data, 60Hz.	27
Table 5	Water-cooled data, 50Hz.	29
Table 6	Glycol-cooled data, 60Hz.	31
Table 7	Glycol-cooled data, 50Hz.	33
Table 8	Chilled water data—60Hz	35
Table 9	Chilled water data—50Hz	36
Table 10	Liebert Challenger 3000 electrical data—60Hz	46
Table 11	Self-contained with SCR reheat 2	47
Table 12	Scroll compressor and main fan (for comparison purposes only)	48
Table 13	Outdoor condensing units.	48
Table 14	Indoor condensing units, water-cooled.	49
Table 15	Liebert MC™ condensers	49
Table 16	Fan speed control fin/tube condensers.	49
Table 17	Indoor condensing units, air-cooled	49
Table 18	VFD-controlled fin/tube condensers.	50
Table 19	Liebert Lee-Temp receiver heater pads for use w/Liebert MC™ and fin/tube condensers	50
Table 20	Drycooler and pump package—95°F (35°C) ambient, 3-phase.	50
Table 21	Liebert fin/tube condensers with Liebert Lee-Temp™	50
Table 22	Drycooler only—95°F (35°C) ambient, single-phase	51
Table 23	Pumps, three-phase	51
Table 24	Liebert Challenger 3000 electrical data—50Hz	52
Table 25	Scroll compressor and main fan (for comparison purposes only)	53
Table 26	Outdoor condensing units.	53
Table 27	Self-contained with SCR reheat	53
Table 28	Indoor condensing units air-cooled	54
Table 29	Indoor condensing units water-cooled	54
Table 30	Fan speed control condensers.	54
Table 31	VFD controlled condenser.	54
Table 32	Liebert Lee-Temp™ condensers	54
Table 33	Liebert Lee-Temp receiver heater pads; for use w/DCSL condensers	54
Table 34	Drycooler & pump package - 35°C (95°F) ambient	54
Table 35	Drycooler only - 35°C (95°F) ambient	55
Table 36	Pumps, three-phase	55

1.0 PRECISION ENVIRONMENTAL CONTROL FOR INDUSTRIAL, TELECOMMUNICATIONS, MEDICAL AND DATA PROCESSING EQUIPMENT

Data processing power is moving from the specialized environment of the computer room to the office and the factory floor.

At the same time, the applications are growing exponentially. From yesterday's spreadsheets and word processors, micro- to mid-range computers control LANs and WANs, manage complex telecommunications systems, optimize manufacturing processes and facilitate sophisticated testing and laboratory functions.

Computers and sensitive electronics tend to be grouped, often in specialized rooms. This makes operation and service easier, but it also creates the need for precision environmental control—the coordinated management of temperature, humidity and air filtration.

1.1 Liebert Challenger 3000

Though electronic equipment rooms share some common protection requirements, their application requirements can vary greatly. The room may or may not have a raised floor or an existing heat rejection loop. Budget and space requirements may limit the options a contractor has.

The Liebert Challenger 3000 is available in 10 configurations, with upflow and downflow air distribution options.

The configurations available allow the Liebert Challenger 3000 to be applied to virtually any scenario. Chilled water models are available to take advantage of a facility's chillers. DX units are available in both self-contained systems, where the compressor is in the indoor unit, and split systems, where the compressor is in a remote condensing unit.

The Liebert Challenger 3000 occupies 7 square feet (.65 square meters) of floor space. It can be located in a corner of the room or against a wall, as all service access is from the front of the unit. With room floor space valued at a premium per square foot, the small footprint of the Liebert Challenger 3000 makes economic good sense.

1.2 Agency Listed

Standard 60Hz units are CSA-certified to the harmonized U.S. and Canadian product safety standard, CSA C22.2 No 236/UL 1995 for "Heating and Cooling Equipment" and are marked with the CSA c-us logo.



Figure 1 System configurations—Chilled water, self-contained

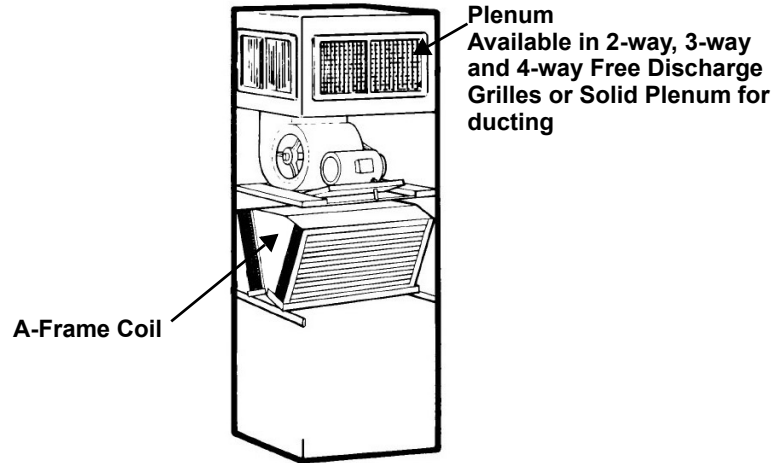

Figure 2 System configurations—Water-cooled, self-contained

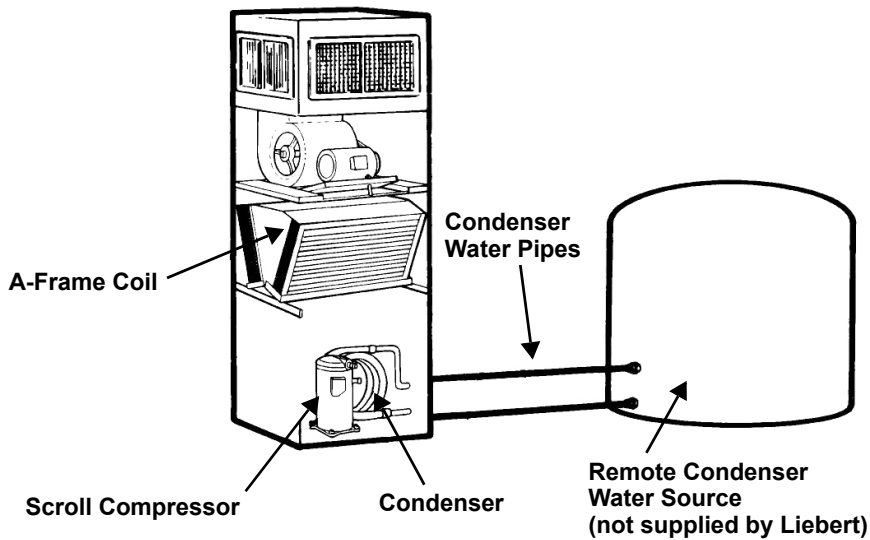

Figure 3 System configurations—Glycol-cooled, self-contained with matching drycooler and pump

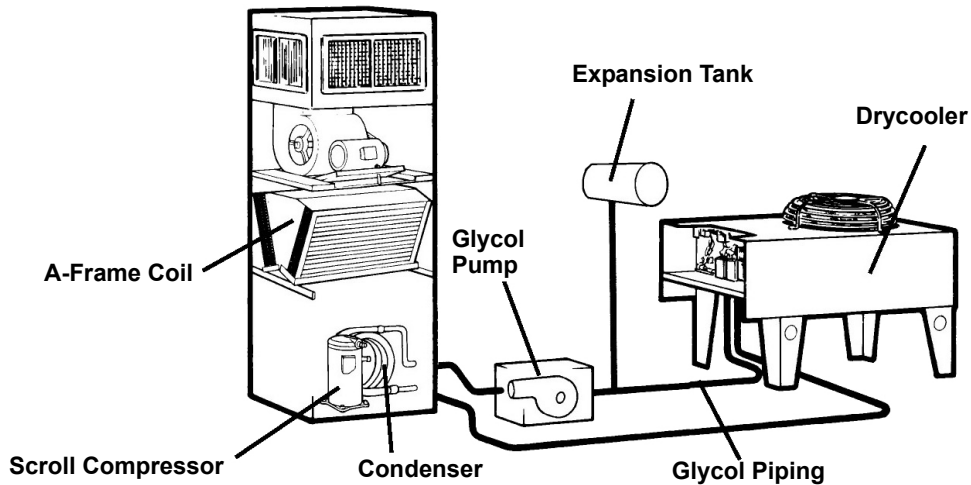

Figure 4 System configurations—Air-cooled, self-contained with matching condensers

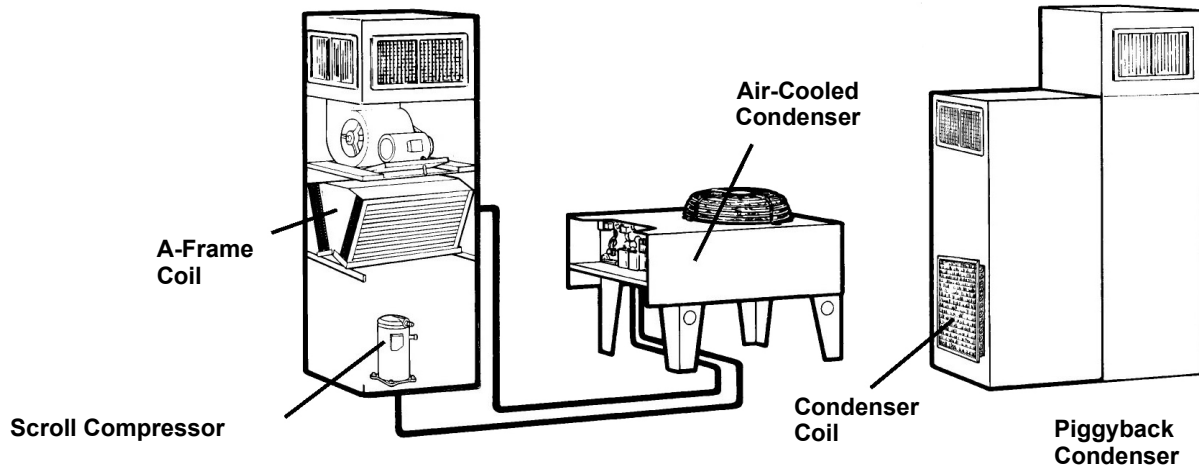

Figure 5 System configurations—GLYCOOL-cooled

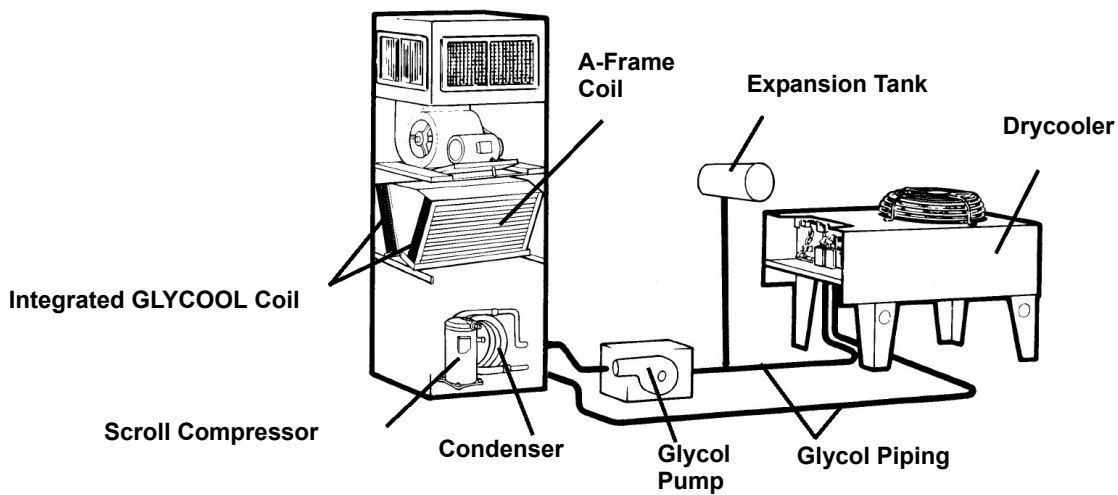
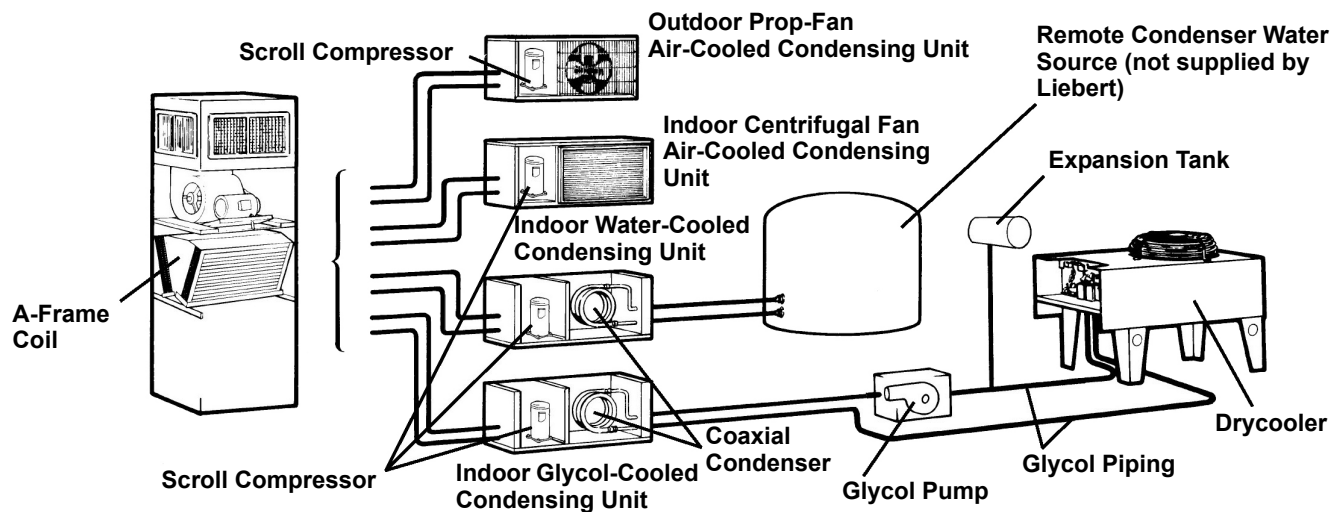

Figure 6 System configurations—Split systems



2.0 STANDARD FEATURES—ALL SYSTEMS

2.1 Cabinet and Frame

The frame, 14 gauge, MIG welded tubular and formed steel, provides maximum support while 1" (25.4mm) deep steel panels with 1-1/2 lb. (.68 kg) insulation protect and quiet the system. The front door can be opened for service without shutting off the system. All components are accessible for service/maintenance through the front of the unit.

Emerson enhances the Liebert Challenger 3000's resistance to corrosion by applying a black, powder-coat finish to all frame components. Exterior panels are similarly protected with durable powder-coating.

2.2 Electrical Panel

The high voltage compartment contains the contactors, transformers and overloads and all other high-voltage components.

Each high voltage component is protected by an overcurrent protective device. The entire high voltage panel is enclosed by a safety lock dead front panel. When the front door is opened by operating personnel, the high voltage components remain enclosed for operator safety.

2.3 Fan Section

The Liebert Challenger 3000 features a quiet, low speed fan assembly with double inlet blower, lifetime lubrication and self-aligning ball bearings. The motor and variable pitch drive are mounted on an adjustable base. The entire blower/ motor assembly is mounted on vibration isolators for smoother operation.

The draw-through design of the fan section provides even air distribution across the coil, controlled air for bypass humidification, elimination of air bypass around the filters and low internal cabinet pressure drop.

2.4 Infrared Humidifier

High-intensity quartz lamps over the stainless steel humidifier pan permit clean, particle-free vapor to be added to the air within 5 to 6 seconds of the electronic call from the Liebert iCOM® control system.

The quartz lamps provide radiant energy that evaporates water in a pure state, without solids.

The infrared humidifier is equipped with an automatic water supply system that significantly reduces cleaning maintenance. This system has a water over-feed to reduce mineral precipitation. A drain valve is provided to easily empty the humidifier pan prior to inspection or servicing. A control valve regulates flow at water pressures between 5 and 150 psig (34.5 and 1034 kPa) and includes a Y-strainer.

2.5 Electric Reheat

The two-stage 304 stainless steel reheat elements are a rigid, fin-tubular design that have extended operation life. The reheat has ample capacity to maintain room dry-bulb conditions during a system call for dehumidification. The two stages give an accurate, controlled response to the requirements of the computer room.

2.6 Filters

The deep pleated 2" (51mm) filters are MERV 8 efficiency per ASHRAE Standard 52.2-2007. The filters are inside the Liebert Challenger 3000 cabinet and are accessible from the front of the unit.

2.7 Liebert iCOM® Control

The Liebert iCOM control offers the highest capabilities in unit control, communication and monitoring of Liebert Thermal Management units.

Liebert iCOM may be used to combine multiple cooling units into a team that operates as a single entity, enhancing the already-high performance and efficiency of Liebert units.

Features of Large and Small Displays

The Liebert iCOM control is available with either a large or small liquid crystal display. The small display is standard; the large display is optional.

- The **Liebert iCOM with small display** has a 128 x 64 dot matrix screen that simultaneously shows two menu icons, along with descriptive text. This display is capable of controlling only the unit it is directly connected to.
- The **Liebert iCOM with large display** has a 320 x 240 dot matrix screen that shows up to 16 menu icons at a time, as well as descriptive text. This display can be used to control a single cooling unit or any cooling unit on a network, regardless of how it is connected—either integrated into a cooling unit or simply connected to the network and mounted remotely.

Liebert iCOM's menu-driven display is used for all programming functions on each connected cooling unit. The Status menu shows the status of the conditioned space, such as room temperature and humidity, temperature and humidity setpoints, alarm status and settings, event histories and the current time.

Figure 7 Upflow GLYCOOL Liebert Challenger 3000 with front return

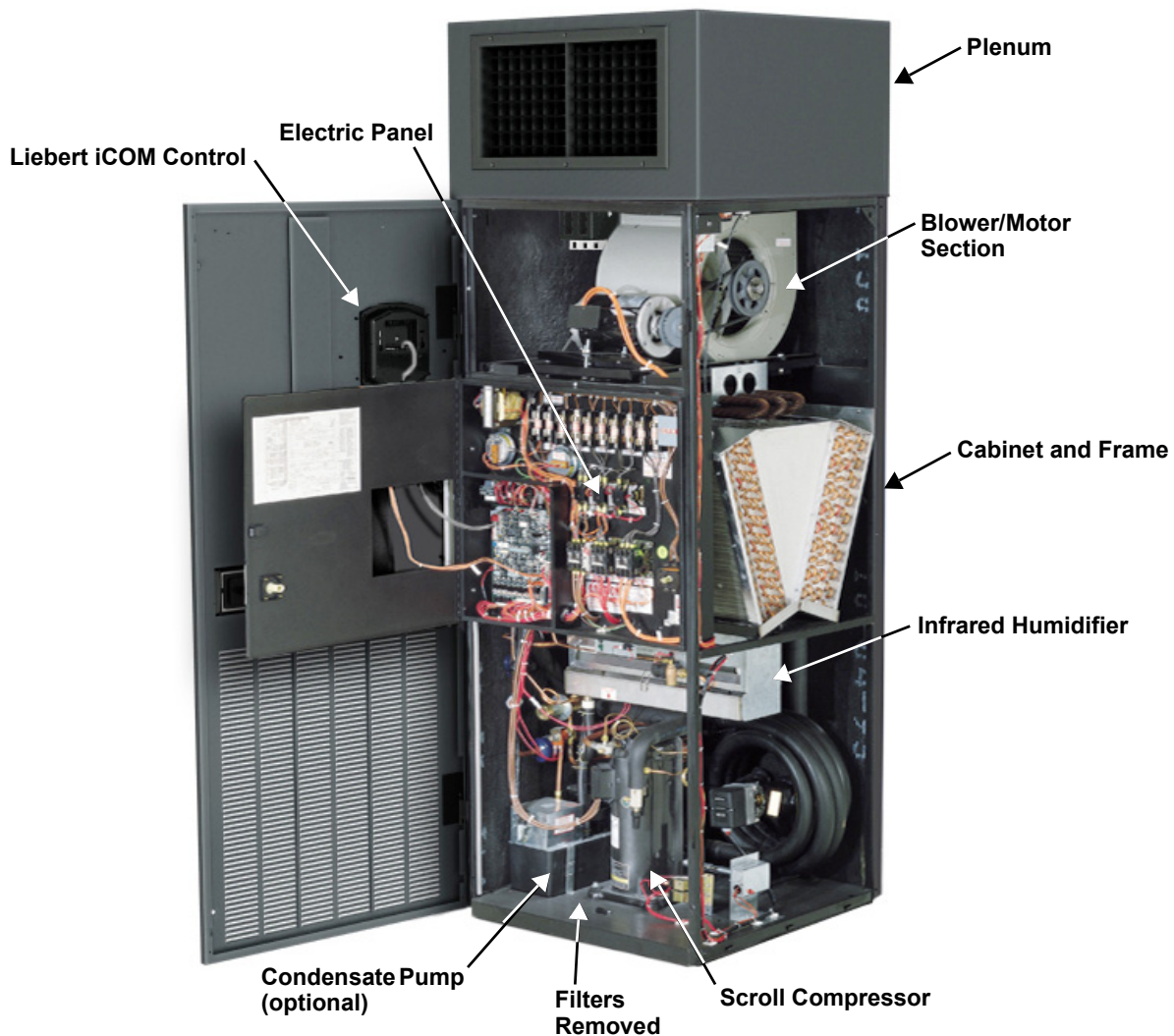

3.0 CHILLED WATER SYSTEM—STANDARD & OPTIONAL FEATURES

3.1 Chilled Water System—Standard Features

3.1.1 Cooling Coil

The chilled water cooling coil is designed for closed-loop applications using properly maintained water. It is constructed of copper tubes and aluminum fins. A-frame coils are used on downflow units and V-frame coils are used on upflow units. To ensure quality, the coil is manufactured to the highest standards in the industry.

3.1.2 Modulating Motor

The flow of chilled water through the cooling coil is controlled by an electronic modulating valve motor. The Liebert iCOM® control will activate the motor when a need for cooling or dehumidification exists. The motor will position the valve to precisely match the needs of the conditioned space.

3.1.3 Three-Way Control Valve

The fully insulated control valve gives the conditioned space the precise cooling needed by electronic equipment. Its unique design requires no overtravel linkages and never requires adjustment. Standard design pressure is 150psi (1034kPa).

3.1.4 Line Insulation

All chilled water piping within the Liebert Challenger 3000 is fully insulated to assure full system capacity and prevent condensation.

3.2 Chilled Water System—Optional Features

3.2.1 Two-Way Control Valve

The valve is the same construction as the three-way valve and works in conjunction with the standard modulating motor. Standard design pressure is 150psi (1034kPa).

3.2.2 Chilled Water Flow Switch

The flow switch will activate the alarm system and/or shut down the system should the chilled water supply be interrupted. The switch is factory-wired and mounted in the chilled water valve compartment.

3.2.3 Hot Water Reheat—Chilled Water Units Only

Controlled by a two-way solenoid valve from the microprocessor control panel, these economical reheats have the capacity to maintain dry bulb conditions when the system is calling for dehumidification. The system is completely pre-piped and includes a control valve and Y-strainer. The reheat coil is constructed of copper tubes and aluminum fins.

3.2.4 High Pressure

For special applications, a high pressure, modulating 3-way or 2-way valve can be provided. The valve is designed for 400 psig (2758 kPa) water pressure.

Figure 8 Chilled water Liebert Challenger 3000 downflow with top return

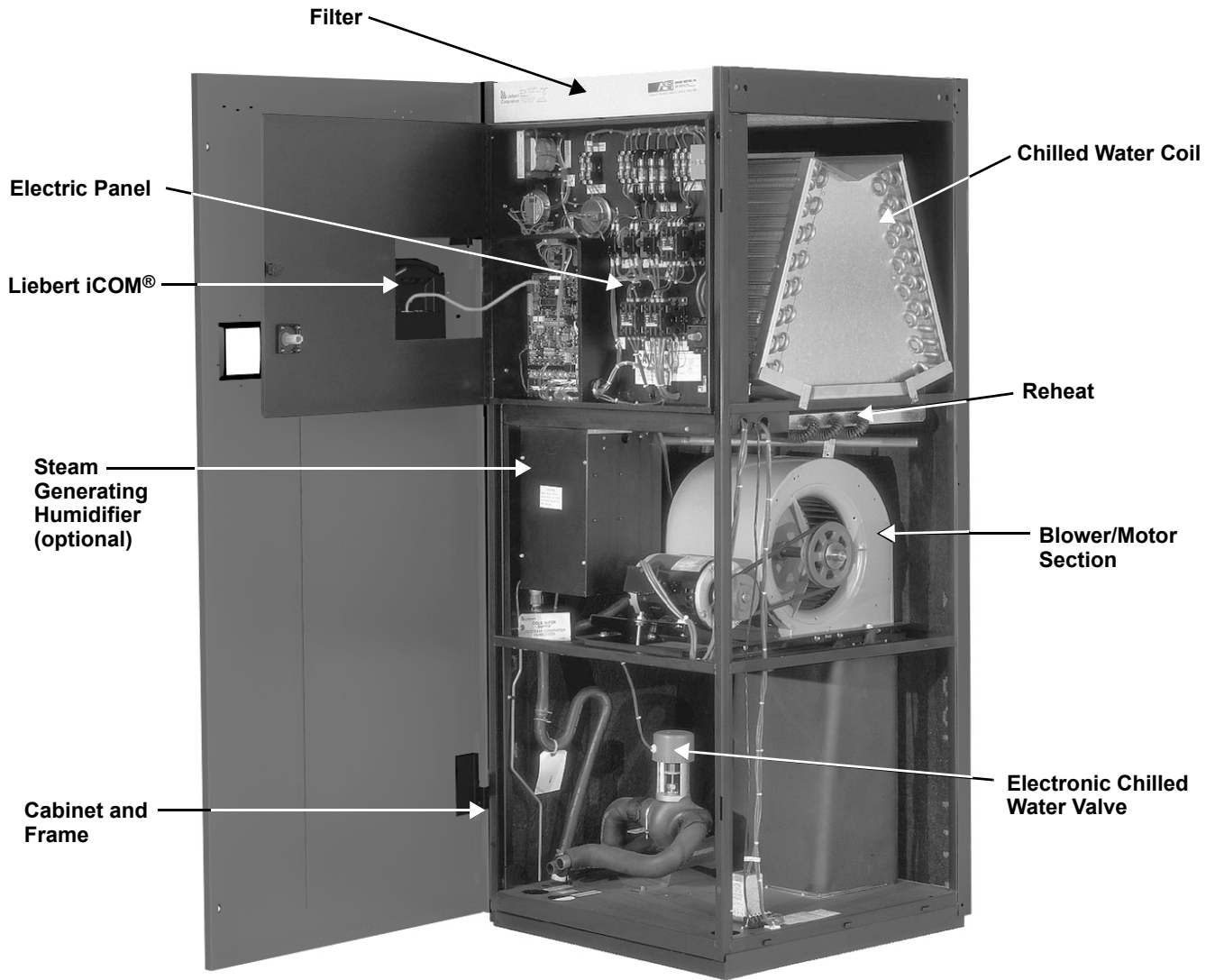

4.0 REFRIGERATION SYSTEMS—STANDARD AND OPTIONAL FEATURES

4.1 Refrigeration System Components—Standard Features

4.1.1 Compressor

The heart of the refrigeration system is the quiet, high-efficiency scroll compressor. The compressors have internal vibration isolating mountings, pressure safety controls and built-in overload protection.

4.1.2 Evaporator Coil

The evaporator coil is designed for the high sensible heat ratio required by electronic equipment applications. The copper tube, aluminum fin coils are configured as A-frame coils on downflow units and V-frame coils on upflow units for smooth air flow through the unit.

4.1.3 Safety Control

Every Liebert Challenger 3000 compressor has a high pressure switch with an exclusive manual reset after high pressure cut-out. This prevents cycling the compressor at high pressure, resulting in greater efficiency and longer compressor life.

4.1.4 Expansion Valve

The externally equalized thermostatic expansion valve smoothly controls the flow of refrigerant through the coil and provides precise control of superheat.

4.1.5 Refrigerant

All systems use R407C refrigerant in conjunction with POE oil.

4.2 Refrigeration System Components—Optional Features

4.2.1 Digital Scroll Compressor

Digital scroll compressors are available only on self-contained models. This compressor type improves efficiency by providing variable cooling capacity (20 - 100%) that can be adjusted to the cooling load.

5.0 AIR-COOLED SYSTEM—STANDARD AND OPTIONAL FEATURES

5.1 Air-Cooled, Self-Contained Systems—Standard Features

5.1.1 Crankcase Heater and Discharge Check Valves

The compressor crankcase heater and discharge check valve prevent the migration of refrigerant to the compressor during off cycles.

5.1.2 Condenser

The Emerson-manufactured low profile, direct drive propeller fan type air-cooled condenser provides quiet, efficient operation.

5.2 Condenser Types

5.2.1 Liebert MC™ Condenser

The Liebert MC condenser is a low-profile, direct-drive propeller fan-type air-cooled unit suitable for mounting outdoors. Constructed with an aluminum cabinet, galvanized steel frame and microchannel coil, the unit is quiet and corrosion resistant. The condenser is quickly and easily installed because all internal wiring is completed at the factory with only electrical connections to be made at the job site. All electrical connections and controls are enclosed in an integral weatherproof section of the condenser.

Premium Efficiency Control/EC Fan

Premium Efficiency Controls and EC fans are matched to provide superior system energy efficiency. The premium control board allows CANbus communication with the Liebert iCOM® control. This communication feature provides compressor run signals, condenser operating mode changes, condenser alarm monitoring, simplified system charging procedures and outdoor ambient temperature monitoring. The EC fan is an integral assembly of an electronically commutated motor, quiet fan blade assembly and finger/hail guard. The fan(s) are controlled by the premium control board using pressure transducer signals from the refrigerant circuit and factory programming to control the refrigerant head pressure.

The premium control board uses inputs from the indoor unit, condenser refrigerant pressures and temperatures and ambient temperatures to modulate the EC fan motor speed from 0 to 100% rpm, maintaining refrigerant head pressure setpoints. The control board, EC fan(s) and transducer(s) are factory-wired. A two-fan condenser will keep all fans turning at the same rpm to maintain head pressure. The control system provides refrigerant head pressure control for outdoor ambient temperatures as low as -30°F (-35°C), provided that the total design range (from minimum to maximum) is 125°F (70°C) or less. Liebert Lee-Temp™ kits are required only when the design temperature ranges exceed 125°F (70°C) for standard match-ups and 115°F (65°C) for Liebert Quiet-Line™ match-ups.

Liebert Lee-Temp Refrigerant Control

The Liebert Lee-Temp head pressure control system assists system starting and maintains proper operating head pressures in outdoor ambient temperatures below the rating point of the Liebert MC control type. The Liebert Lee-Temp system utilizes a head pressure control valve, extra refrigerant and insulated refrigerant receiver with heater pad. The head pressure control valve balances the system condensing requirements by modulating the flooding charge in the condenser coil.

The Liebert Lee-Temp kit is optional for condensers and is field-installed. Liebert MC control boards are factory-configured for Liebert Lee-Temp to modulate the fans based on ambient temperature and overriding fans to a faster speed if pressures exceed setpoints.

5.2.2 Liebert Fin/Tube Condenser

The Liebert condenser is low-profile direct-drive propeller fan-type air cooled unit suitable for mounting outdoors. Constructed with an aluminum cabinet and a copper-tube aluminum fin coil, the unit is quiet and corrosion resistant. The condenser is quickly and easily installed, because all internal wiring is completed at the factory with only electrical connections to be made at the job site. All electrical connections and controls are enclosed in an integral weatherproof section of the condenser.

Fan Speed

Fan speed control utilizes a wave-chopper control to vary the air volume over the condenser coil, based on refrigerant head pressure. The fan motor next to the electrical panel is a single-phase, permanent split capacitor motor with motor speed adjusted in response to refrigerant pressure. The balance of fans on multi-fan units cycle on ambient thermostats. The control system provides refrigerant head pressure control for outdoor ambients as low as -20°F (-28.9 °C).

Variable Frequency Drive

VFD condenser control system utilizes a variable frequency drive, inverter duty fan motor operating from 0% to 100% motor rpm based on head pressure, sensed by refrigerant pressure transducers. VFD, ambient-temperature thermostat(s), motor overload protection and electrical control circuit are factory-wired in the integral control panel. VFD controls the fan adjacent to the connection end of the condenser and remains energized with active compressor operation. The balance of fans on multi-fan units cycle on ambient thermostats. This system provides refrigerant head pressure control for outdoor ambients as low as -20°F (-28.9°C).

Surge Protective Device—A surge protective device (SPD) is standard in VFD condenser models. Surge protection is necessary because rooftop voltage supply often is not conditioned the same as the voltage supply inside a data center. The SPD is designed to protect sensitive electronic condenser components from high voltage transients, up to 25kVA/phase.

An illuminated green LED indicates power supply is On and panel status is OK. An illuminated red LED indicates conditions require service and the SPD may require replacement to restore surge protection to the condenser.

Liebert Lee-Temp™ Refrigerant Control

The Liebert Lee-Temp head pressure control system is designed to maintain proper operating head pressures in outdoor temperatures down to -30°F (-34.4°C). The condensers utilize head pressure control valves, extra refrigerant and insulated refrigerant receivers with heater pads. Condenser fan controls are either fan cycling on ambient temperature or constant on. Liebert Lee-Temp control is required for Liebert Quiet-Line™ Condensers.

Figure 9 Air-cooled condenser with Liebert Lee-Temp

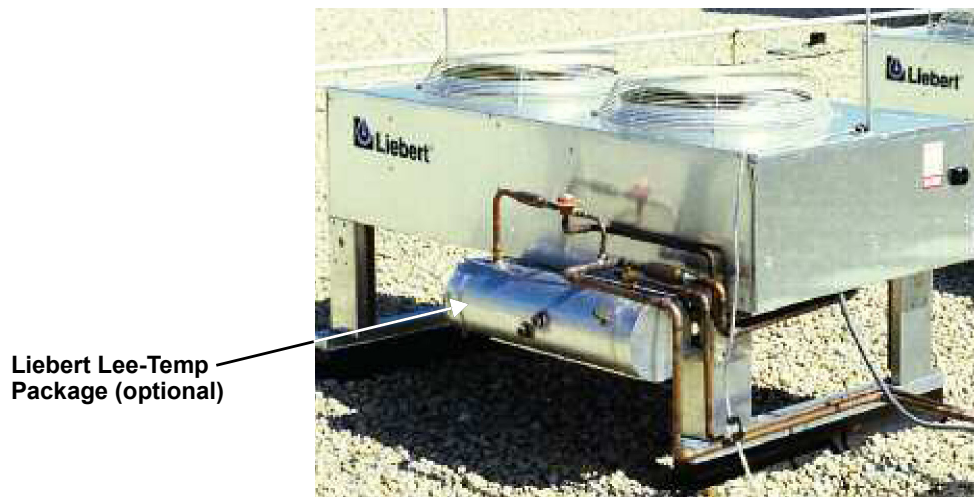

Series PB Indoor Condenser

The Series PB condenser converts the Liebert Challenger 3000/Liebert Lee-Temp™ system into a self-contained package when an outdoor location for the air-cooled condenser is not practical.

Liebert Quiet-Line™ Condensers

Liebert Quiet-Line condensers can help your facility meet the strictest noise codes and do so at less expense than traditional condensers with acoustical shielding.

5.3 Air-Cooled Split Systems—Standard Features

5.3.1 Centrifugal Fan, Indoor Condensing Unit

The centrifugal condensing unit may be connected to the evaporator section by means of pre-charged refrigeration lines (3 ton only). This greatly simplifies installation and keeps installation costs low. The copper-tube, aluminum-fin coil is equipped with low temperature controls to assure year-round operation to -30°F (-34.4°C). The condensing unit is completely factory-wired, charged and tested and is ready for final connections.

The centrifugal fan condensing unit includes standard scroll compressor, condenser coil, centrifugal blower assembly, high-pressure switch, Liebert Lee-Temp head pressure control.

Condensing unit has hot gas bypass standard feature which bypasses hot gas around the compressor directly to the suction side of the compressor to provide capacity control and reduce compressor cycling. System includes liquid injection valve to maintain proper suction superheat.

Unit must be mounted indoors. Duct flanges are provided.

5.3.2 Propeller Fan, Outdoor Condensing Unit

The air-cooled condensing unit can be mounted on the roof or a ground level site. The condensing unit housing is manufactured of galvanized steel with a powder coat finish. The copper-tube, aluminum-fin coil is equipped with low temperature controls to assure year-round operation to -30°F (-34.4°C). The condensing unit is completely factory-wired, charged and tested and is ready for final connections. (See illustration below)

The standard prop fan condensing unit includes standard scroll compressor, prop fan, high head pressure switch, hot gas bypass and Liebert Lee-Temp head pressure control (for operation down to -30°F [-34.4°C] ambient.)

Figure 10 Outdoor propeller fan condensing unit



Prop-fan condensing units are available in three configurations:

- 95°F (35°C) ambient (standard selection)
- 105°F (40°C) ambient for high ambient conditions
- 95°F (35°C) ambient Quiet-Line for low noise level conditions below 58 dBA

5.4 Air-Cooled Split Systems—Optional Features

5.4.1 Non-Fused Disconnect Switch

A factory-installed, non-fused disconnect switch allows unit to be turned off for maintenance. The disconnect switch is available only on centrifugal fan condensing units.

5.4.2 Pre-Charged Line Sets

3 Ton Only: Consists of one pre-charged liquid line and one pre-charged insulated suction line of soft copper tubing. Each line has one male quick-connect coupling and one female quick-connect coupling with an access valve connection.

Available in 15 ft. (4.6m) and 30 ft. (9.1m) lengths for interconnection of remote located condenser module. Maximum recommended distance between evaporator and condenser modules with pre-charged line sets is 45 ft. (13.7m). For longer runs, use sweat adapter kit.

5.4.3 Refrigerant-Line Sweat Adapter Kit

3 Ton Only: Contains two suction and two liquid line compatible fittings that allow field-supplied interconnecting refrigerant lines to be used.

6.0 WATER/GLYCOL-COOLED SYSTEMS—STANDARD AND OPTIONAL FEATURES

6.1 Water/Glycol Self-Contained Systems—Standard Features

6.1.1 Liquid-Cooled Condensers

A co-axial condenser provides ample capacity to handle the heat rejection needs of the system while using a minimum of liquid and low total pressure drop.

6.1.2 Regulating Valves—Non-Digital Scroll Compressor Models Only

Head pressure operated regulating valves accurately control the condensing temperature and maintain system capacity for various entering liquid flow rates and temperatures. Two-way valves with bypass are standard. Standard design pressure is 150psi (1034kPa).

6.2 Water/Glycol-Cooled, Self-Contained System—Optional Features

6.2.1 Three-way Regulating Valves

Three-way valves provide accurate control of condensing temperature and thus maintain constant system capacity while also keeping the condenser water flow rate constant. Standard design pressure is 150psi (1034kPa).

6.2.2 High Pressure

The high pressure option for the condenser circuit consists of a regulating valve and a condenser rated at 350 psig (2413 kPa) water-pressure. This option is required in applications with large static head pressures. Liebert Challenger 3000 models with a digital scroll compressor and motorized ball valve are rated at 400psig (2758kPa) as standard.

6.2.3 Motorized Ball Valve—Digital Scroll Compressor Models Only

On digital scroll units, discharge pressure is controlled by a motorized ball valve. During unloaded operation, the pressure changes during each digital cycle could result in excessive repositions with a pressure operated water regulating valve. The control algorithm for the motorized ball valve uses an intelligent sampling rate and adjustable pressure thresholds to reduce valve repositions. The valve assembly consists of the brass valve, linkage and actuator. Standard design pressure is 400psig (2758kPa).

Manual Control

The valve can be set manually by disconnecting AC power, depressing the manual override button on the valve actuator, and adjusting the valve position with the handle. The Service menu offers the option of controlling the motorized ball valves using manual mode to override the normal control. This provides an internal bypass; refer to the Liebert iCOM[®] user manual, SL-18835, available at the Liebert Web site: www.liebert.com

6.2.4 Compressor Crankcase Heater

A compressor crankcase heater is available to prevent the migration of refrigerant to the compressor during off cycles.

6.2.5 Hot Gas Reheat

The hot gas reheat assembly consists of a 3-way directional solenoid operated valve and a hot gas reclaim coil.

6.3 Water/Glycol Split System—Standard Features

6.3.1 Water/Glycol-Cooled, Indoor Condensing Units

The water-cooled condensing unit is factory-charged and sealed, making it ready to be installed quickly and easily. The counter-flow coaxial condenser with two-way or three-way regulating valve designed for 150 psi (1034.3 kPa) is matched to the heat rejection requirements of the compressor for a variety of flow rates and fluid temperatures.

The condensing unit has a hot gas bypass standard feature that bypasses hot gas around the compressor directly to the suction side of the compressor to provide capacity control and reduce compressor cycling. System includes liquid injection valve to maintain proper suction superheat.

6.4 Water/Glycol-Cooled, Split System—Optional Features

6.4.1 High Pressure

The high pressure option for the condenser circuit consists of a two-way or three-way water regulating valve and condenser rated at 350 psig (2413 kPa) water pressure. This option is required in applications with large static heads.

6.4.2 Factory-Installed Non-Fused Disconnect Switch

Allows unit to be turned off for maintenance. Disconnect switch is available on indoor condensing units only.

6.4.3 Pre-Charged Line Sets—3 Ton Only

Consists of one pre-charged liquid line and one pre-charged insulated suction line of soft copper tubing. Each line has one male quick-connect coupling and one female quick-connect coupling with an access valve connection.

Available in lengths of 15 ft. and 30 ft. (4.6m and 9.1m) for interconnection of remote located condenser module. The maximum recommended distance between evaporator and condenser with pre-charged line sets is 45 ft. (13.7m). For longer runs, use sweat adapter kit.

6.4.4 Refrigerant-Line Sweat Adapter Kit

3 Ton Only—Contains two suction and two liquid line compatible fittings that allow field-supplied interconnecting refrigerant lines to be used.

6.5 Glycol-Cooled Systems—Standard Heat Rejection Devices for Self-Contained and Split Systems

6.5.1 Fan Speed Control Drycooler

The Emerson-manufactured Fan Speed Control drycooler is constructed of aluminum and features copper tubes and aluminum fin design. It is low profile, propeller fan type and provides quiet, trouble free heat rejection. The drycooler features a variable speed fan motor and a specially engineered solid state fan speed transducer. The transducer senses the temperature of the leaving glycol and modulates the speed of the fan to maintain proper glycol temperatures. An integral, factory-wired and tested control panel reduces installation time and includes drycooler and pump controls.

6.5.2 Glycol Pump Package

The glycol system includes a matching centrifugal glycol pump. It is mounted in a vented, weatherproof enclosure.

6.6 Glycol-Cooled Systems—Optional Heat Rejection Devices for Self-Contained and Split Systems

6.6.1 Dual Pump Package

The dual pump package features two full size glycol pumps, each capable of providing sufficient flow for system operation. A flow switch will sense the loss of flow, should the lead pump fail, and automatically command the standby pump to start. The complete system includes dual pump housing, pumps, lead-lag switch and flow switch (for field installation). The dual pump package provides redundancy, protecting against costly downtime in the computer room.

6.6.2 Liebert Quiet-Line™ Drycoolers

Liebert Quiet-Line Drycoolers can help your facility meet the strictest noise codes, and do so at less cost than traditional drycoolers with acoustical shielding.

7.0 GLYCOOL SYSTEMS—STANDARD AND OPTIONAL FEATURES

The Liebert GLYCOOL free-cooling system is integrated with a glycol-cooled Liebert Challenger 3000.

The GLYCOOL system is a normal glycol system with the addition of a second cooling coil in the air handling unit and a three-way valve. During colder months, the glycol solution returning from the outdoor drycooler is routed to the second coil, and becomes the primary source of cooling for the room. At drycooler fluid temperatures, about 8°F (4.4°C) below room return temperature, cooling begins in the second coil. As fluid temperatures drop, compressor operation stops, and the total cooling needs of the room are maintained by the second coil (Econ-O-Coil).

The GLYCOOL system contains all the standard features of a glycol-cooled system plus the following.

7.1 GLYCOOL Self-Contained Systems—Standard Features

7.1.1 Comparative Temperature Monitor

A solid-state temperature monitor compares the room air temperature and entering glycol temperature. When air temperature is higher than glycol temperature, the monitor communicates to the Liebert iCOM® that “free-cooling” is available.

7.1.2 GLYCOOL Coil

The GLYCOOL coil is strategically located in the return air stream of the environmental control system. This coil is designed for closed-loop applications using properly treated glycol solutions.

The air is filtered before entering the coil and then is either pre-cooled or totally cooled before entering the refrigeration coil. The glycol flow to the coil is controlled by a pre-piped modulating three-way valve. When supplied with a sufficiently cooled glycol solution, the coil provides the same cooling capacity as is obtained during the refrigeration cycle of the compressor.

7.1.3 GLYCOOL Three-Way Control Valve

The GLYCOOL three-way control valve opens full anytime the temperature of the glycol solution is below room temperature, to take full advantage of all possible free-cooling. As the outdoor ambient drops, the three-way control valve modulates the flow to the GLYCOOL coil. It maintains constant temperature in the room and includes operating linkage and electronic motor. Unlike other valves of this nature, there is no over travel linkage or end switches to be adjusted. Standard design pressure is 150psi (1034kPa).

7.1.4 Glycol-Regulating Valve

A head pressure operated three-way glycol regulating valve accurately controls the condensing temperature and system capacity for various entering glycol temperatures. The valve has three-way action.

7.2 GLYCOOL Self-Contained System—Standard Heat Rejection Devices

7.2.1 Drycooler

The Emerson-manufactured drycooler is constructed of aluminum with a copper tube aluminum fin coil. The low profile design features one or more direct-drive propeller type fans, balanced to the heat rejection load. An integral, factory-wired and tested control panel reduces installation time and includes drycooler and pump controls.

7.2.2 Glycol Pump Package

The glycol system includes a matching centrifugal glycol pump. It is mounted in a vented, weatherproof enclosure.

Figure 11 Upflow GLYCOOL Liebert Challenger 3000

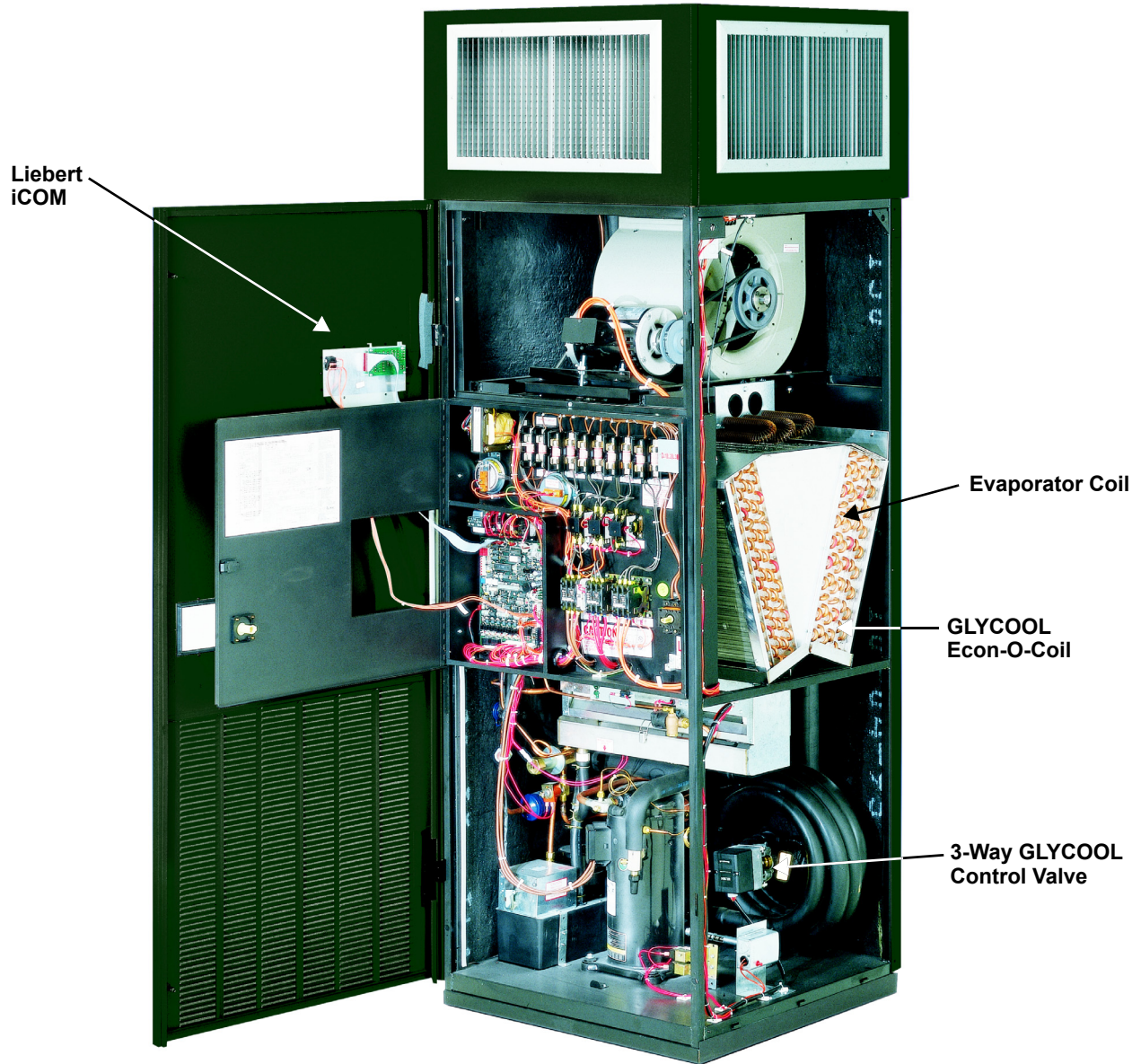

7.3 GLYCOOL Self-Contained Systems—Optional Features

7.3.1 High Pressure

For high pressure applications, the GLYCOOL system can be equipped with components rated at 300psig (2069kPa). Liebert Challenger 3000 models with a digital scroll compressor and motorized ball valve are rated at 300psig (2068kPa) as standard.

7.3.2 Motorized Ball Valve—Digital Scroll Compressor Models Only

On digital scroll units, discharge pressure is controlled by a motorized ball valve. During unloaded operation, pressure changes during each digital cycle could result in excessive repositions with a pressure operated water regulating valve. The control algorithm for the motorized ball valve uses an intelligent sampling rate and adjustable pressure thresholds to reduce valve repositions. The valve assembly consists of the brass valve, linkage and actuator. Standard design pressure is 300psig (2068kPa).

7.3.3 Compressor Crankcase Heater

A compressor crankcase heater is available to prevent the migration of refrigerant to the compressor during off cycles.

7.4 GLYCOOL Self-Contained System—Optional Heat Rejection Devices

7.4.1 Dual Pump Package

The dual pump package features two full size glycol pumps, each capable of providing sufficient flow for system operation. A flow switch will sense the loss of flow, should the lead pump fail, and automatically command the standby pump to start. The complete system includes dual pump housing, pumps, lead-lag switch and flow switch (for field installation). The dual pump package provides redundancy, protecting against costly downtime in the computer room.

7.4.2 Liebert Quiet-Line Drycoolers

Liebert Quiet-Line Drycoolers can help your facility meet the strictest noise codes, and do so at less cost than traditional drycoolers with acoustical shielding.

8.0 OPTIONAL EQUIPMENT—ALL SYSTEMS

8.1 Dual-Float Condensate Pump

The dual-float condensate pump is factory-installed in the bottom of upflow units and field-installed under the raised floor for downflow units (11 in. [280mm] minimum floor height required).

The pump is complete with sump, motor and pump assembly and automatic dual-float control.

The condensate pump includes connections to unit. The secondary float sends an alarm signal to the Liebert iCOM®, which will display the condensate pump alarm and shut down the unit upon a high water condition. One customer N/O contact is also available.

Table 1 Condensate pump capacity

Voltage	Hz	Capacity GPH (l/s)	Head Pressure ft. (kPa)
200/230	50	300 (1135)	30 (89)
208/230	60	400 (1533)	30 (89)
380/415	50	300 (1135)	30 (89)
460	60	420 (1590)	30 (89)

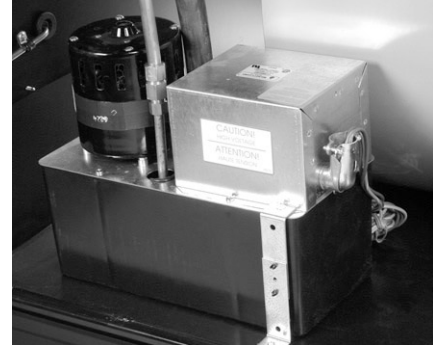

8.2 Steam Generating Humidifier

Clean, pure steam is generated in a disposable canister that is complete with supply and drain valves, electronic controls and steam distributor. The humidifier is provided with an automatic flush cycle to lengthen service life. An indicator on the Liebert Challenger 3000 monitor panel is activated when the canister should be changed.

8.3 Remote Temperature/Humidity Sensors

The remote temperature/ humidity sensors permit monitoring room conditions from an external source. They are encased in an attractive case and are provided with a plug compatible shielded cable in various lengths.

8.4 Disconnect Switch—Locking Type

The locking disconnect switch, mounted in the electrical panel, is connected to the safety lock dead front panel of the system and is interlocked mechanically. This prevents opening the panel unless the switch is in the Off position. The locking disconnect switch complies with local codes as well as those of the NEC. It provides 65kA SCCR for 60Hz units and 5kA for 50Hz units.

8.5 Disconnect Switch—Non-Locking

The disconnect operating handle protrudes through the front of the system for easy access. The disconnecting switch meets NEC codes; available on 50Hz models only and provides 5kA SCCR.

8.6 SCR Reheat

This reheat uses stainless steel elements and also includes the necessary sensors and controls to provide variable heat output to help maintain tighter control of room conditions, especially in lightly loaded applications. (Contact factory for available voltages.) Direct expansion, standard scroll units only.



Steam-Generating Humidifier



**Disconnect Switch
(Locking & Non-Locking)**

8.7 Adjustable Floor Stand

Available in heights from 9" to 24" (228.6 to 609.6mm) in 3" (76.2mm) increments, adjustable ± 1.5 " (38.1mm). Allows for installation and connection of the Liebert Challenger 3000 prior to installation of the raised floor. A modular, field-installed turning vane can be added to the floor stand.



NOTE

Some options or combinations of options may result in reduced air flow. Consult factory for recommendations.

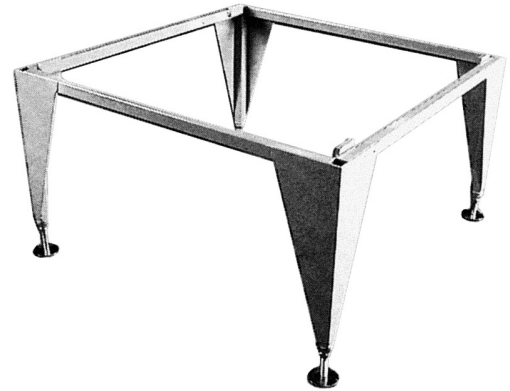

8.8 High-Efficiency Filter

Optional filters are available in lieu of standard package. A 4" (102mm) MERV 8 or 11 filter may be specified. (Efficiency based on ANSI/ASHRAE 52.2-2007). 2" (51mm) MERV 8 pre-filters may also be specified.

8.9 Heavy Gauge Industrial Panels

These 16 ga. panels include heavy duty gaskets to provide satisfactory system operation when located outside the conditioned space in less-than-desirable environments.

8.10 High External Static Blowers

These blower/motor packages are available on upflow models where external static pressures are up to 2.0 inches (500Pa) on 60Hz units, and up to 1.5 inches (370Pa) on 50Hz units. These blowers are rigidly mounted for ducting directly to the blower housing. (Contact your local Emerson representative for specific applications.)

8.11 High-Efficiency Motors

These motors replace the standard efficiency motors to provide increased energy savings during operation (consult factory for specific efficiencies).

8.12 Plenums

Standard height of 18" (457mm) with top duct connection or 2-way, 3-way or 4-way grille discharge styles available.

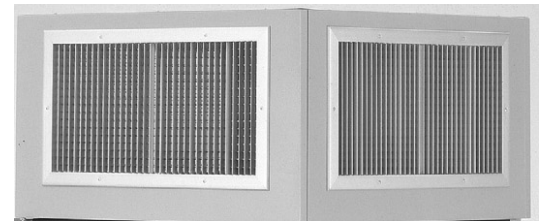

Plenum With Two-Way Grille

8.13 Smoke Sensor

The smoke sensor samples the return air, shuts down the unit upon activation, and sends visual and audible alarms. Dry contacts are available for a remote customer alarm. This smoke sensor is not intended to function as or replace any room smoke detection system that may be required by local or national codes.

8.14 High Temperature Sensor

The high temperature sensor senses return air temperature of the system. Upon sensing high temperatures, the environmental control system is shut down. A high temperature sensor is required by codes in certain areas.

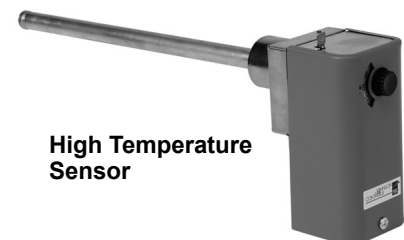

High Temperature Sensor

9.0 COMPREHENSIVE MONITORING DEVICES—OPTIONAL

You will find a full range of monitoring and control systems, communications modules designed to interface Liebert equipment with a variety of building management systems, plus stand-alone monitoring, control and leak detection devices.

9.1 Enterprise Monitoring Systems

Liebert SiteScan® Web

Liebert SiteScan Web is a comprehensive critical systems monitoring solution dedicated to ensuring reliability through graphics, event management and data extrapolation. The standard Web interface allows users easy access from anywhere at anytime.

Liebert SiteScan Web enables communications from Liebert environmental and power units—as well as many other pieces of analog or digital equipment—to a front end software package that provides monitoring, control and alarm management.

- Single- and multi-site applications.
- Event management and unit control.
- Trend and historical data captures and reporting.
- Full ASHRAE BACnet compatibility.
- Java based.
- Microsoft® Windows® 2000 and Windows® XP compatible.

Liebert SiteLink™

- Connectivity to building management systems using Modbus and BACnet.

Liebert Site I/O™

- Integrates sensors and contacts.

Liebert Site TPI™

- Integrates non-Liebert equipment.

9.2 Network Monitoring Systems

Liebert IntelliSlot™ cards provide Ethernet and RS-485 connectivity for Liebert equipment. Operating status and alarms are communicated via the networks to external systems utilizing industry-standard open protocols.

9.2.1 Liebert IntelliSlot Unity® Card

The Liebert IntelliSlot Unity Card is the next generation of communications interface enabling infrastructure management and building management applications via a common platform for monitoring, control and alarm management. The card provides Ethernet and RS-485 connectivity to support 10/100 Mbit Ethernet, IPv4 and IPv6, HTTP/HTTPS for device Web page access, Emerson Protocol for communicating with Trellis™ and Liebert Nform® software applications, and LIFE™ technology for supporting remote service delivery applications. The card also supports third-party protocols (Modbus/IP, BACnet/IP, Modbus/485 and SNMP v1/v2c/v3) for building management and network management applications.

9.2.2 Liebert SiteScan Interface Card

The Liebert SiteScan Interface Card provides RS-485 connectivity from Liebert equipment to Liebert SiteLink modules for the Liebert SiteScan Web application. The card provides pass-through communication of the Emerson Protocol for monitoring, control and alarm management.

9.2.3 Leak-Detection Solutions

Zone detectors with cable or single-point detectors provide fast and accurate indication of water in your critical space. These systems communicate with your unit or with a separate monitoring system. Area water detection cable with distance measurement and monitoring protects the entire room. This system quickly and accurately calculates and displays the location of water on the cable, allowing prompt leak detection and correction.

Figure 12 Liebert Liqui-tect® zone and area leak detection



10.0 AIR-COOLED DATA—60HZ

Table 2 Liebert Challenger 3000 air-cooled data—60Hz

System Type	BF = Downflow BU = Upflow	Self-Contained (Indoor Standard / Digital Compressor)		Split Systems - Standard Scroll Compressor			
				w/Outdoor Prop-Fan Condensing Unit		w/Indoor Centrifugal Condensing Unit	
Indoor Unit		BF/BU 042A	BF/BU 067A	BF/BU 036E	BF/BU 060E	BF/BU 036E	BF/BU 060E
Net Capacity Data - Standard Air Volume *		BTU/H (kW)	BTU/H (kW)	BTU/H (kW)	BTU/H (kW)	BTU/H (kW)	BTU/H (kW)
85°F DB, 65°F WB (29°C DB, 18°C WB) 33% RH							
Total		44,500 (13.0)	67,900 (19.9)	43,000 (12.6)	65,700 (19.2)	42,500 (12.5)	66,000 (19.3)
Sensible		43,400 (12.7)	67,900 (19.9)	43,000 (12.6)	65,700 (19.2)	42,500 (12.5)	66,000 (19.3)
80°F DB, 63°F WB (27°C DB, 17.2°C WB) 38% RH							
Total		42,300 (12.4)	63,800 (18.7)	40,900 (12.0)	62,200 (18.2)	40,100 (11.7)	62,500 (18.3)
Sensible		39,700 (11.6)	63,300 (18.5)	40,200 (11.8)	61,200 (17.9)	39,600 (11.6)	61,400 (18.0)
75°F DB, 61°F WB (24°C DB, 16°C WB) 45% RH							
Total		40,600 (11.9)	60,500 (17.7)	38,900 (11.4)	59,300 (17.4)	38,200 (11.2)	59,600 (17.5)
Sensible		35,300 (10.3)	56,600 (16.6)	36,200 (10.6)	54,600 (16.0)	35,700 (10.5)	54,800 (16.1)
Net Capacity Data - Optional Air Volume *							
85°F DB, 65°F WB (29°C DB, 18°C WB) 33% RH							
Total		45,800 (13.4)	68,200 (20.0)	48,800 (14.3)	66,000 (19.3)	43,900 (12.9)	66,300 (19.4)
Sensible		45,800 (13.4)	68,200 (20.0)	48,800 (14.3)	66,000 (19.3)	43,900 (12.9)	66,300 (19.4)
80°F DB, 63°F WB (27°C DB, 17.2°C WB) 38% RH							
Total		43,100 (12.6)	63,900 (18.7)	42,000 (12.3)	62,100 (18.2)	41,200 (12.1)	62,400 (18.3)
Sensible		42,700 (12.5)	63,800 (18.7)	42,000 (12.3)	61,800 (18.1)	41,200 (12.1)	62,100 (18.2)
75°F DB, 61°F WB (24°C DB, 16°C WB) 45% RH							
Total		41,000 (12.0)	60,300 (17.7)	39,400 (11.5)	59,000 (17.3)	38,600 (11.3)	59,400 (17.4)
Sensible		38,200 (11.2)	57,600 (16.9)	38,700 (11.3)	55,300 (16.2)	38,100 (11.2)	55,700 (16.3)
Fan Data (Blower A12x9AT) **							
Std. Air, CFM (CMH)		1800 (3060)	2800 (4760)	1800 (3060)	2800 (4760)	1800 (3060)	2800 (4760)
Std. Fan Motor, hp (kW)		0.75 (0.56)	2 (1.5)	0.75 (.56)	2 (1.5)	0.75 (.56)	2 (1.5)
Opt. Air, CFM (CMH)		2300 (3910)	3000 (5100)	2300 (3910)	3000 (5100)	2300 (3910)	3000 (5100)
Opt. Fan Motor, hp (kW)		1 (0.75)	2 (1.5)	1 (0.75)	2 (1.5)	1 (0.75)	2 (1.5)
External Static, in. WG (Pa)		0.3 (75)	0.3 (75)	0.3 (75)	0.3 (75)	0.3 (75)	0.3 (75)
Evaporator Coil (BF: A-Frame; BU: V-Frame)							
Face Area, ft. ² (m ²)		6.67 (0.62)	6.67 (0.62)	6.67 (0.62)	6.67 (0.62)	6.67 (0.62)	6.67 (0.62)
Rows		3	4	3	4	3	4
Face Velocity, FPM (m/s)		255 (1.3)	405 (2.1)	255 (1.3)	405 (2.1)	255 (1.3)	405 (2.1)
Electric Reheat 2 Stage (Stainless Steel, Fin Tubular) - Standard							
Capacity, BTU/H (kW) (including motor heat)		33,400 (9)	56,200 (15)	33,400 (9)	56,200 (15)	33,400 (9)	56,200 (15)
Hot Water Reheat 180°F (82.2°C) E.W.T., 75°F (23.9°C) E.A.T. - Optional (Includes standard air volume and optional fan motor hp)							
Capacity, BTU/H (kW) (including motor heat)		71,400 (20.9)	88,700 (26.0)	71,400 (20.9)	88,700 (26.0)	71,400 (20.9)	88,700 (26.0)
Flow Rate, GPM (l/s)		5.0 (.32)	5.0 (.32)	5.0 (.32)	5.0 (.32)	5.0 (.32)	5.0 (.32)
Pressure drop, ft. (kPa)		16.9 (50.4)	16.9 (50.4)	16.9 (50.4)	16.9 (50.4)	16.9 (50.4)	16.9 (50.4)

* Capacity data is certified to ASHRAE 127-2007 standard. Fan motor heat has been subtracted, resulting in "net" capacity.

** Airflow data rated with 2" MERV 8 filter, rated per ASHRAE 52.2-2007. Some options or combinations of options may result in reduced airflow. Consult factory for recommendations.

Table 2 Liebert Challenger 3000 air-cooled data—60Hz (continued)

System Type	BF = Downflow BU = Upflow	Self-Contained (Indoor Standard / Digital Compressor)		Split Systems - Standard Scroll Compressor			
				w/Outdoor Prop-Fan Condensing Unit		w/Indoor Centrifugal Condensing Unit	
Indoor Unit		BF/BU 042A	BF/BU 067A	BF/BU 036E	BF/BU 060E	BF/BU 036E	BF/BU 060E
Net Capacity Data - Standard Air Volume *		BTU/H (kW)	BTU/H (kW)	BTU/H (kW)	BTU/H (kW)	BTU/H (kW)	BTU/H (kW)
Infrared Humidifier - Standard							
Capacity, lb/hr (kg/hr)		11 (5)	11 (5)	11 (5)	11 (5)	11 (5)	11 (5)
kW		4.8	4.8	4.8	4.8	4.8	4.8
Steam Generating Humidifier - Optional							
Capacity, lb/hr (kg/hr)		11 (5)	11 (5)	11 (5)	11 (5)	11 (5)	11 (5)
kW		3.9	3.9	3.9	3.9	3.9	3.9
Filter Section - MERV rating per ASHRAE 52.2-2007 - Deep Pleated Disposable Type Standard 2" (51mm) MERV 8, or Optional 4" (102mm) MERV 8 or MERV 11; 2" (51mm) MERV 8 pre-filter available							
Nominal Size, in. (mm)		28.5 x 29.5 (724 x 749)	28.5 x 29.5 (724 x 749)	28.5 x 29.5 (724 x 749)	28.5 x 29.5 (724 x 749)	28.5 x 29.5 (724 x 749)	28.5 x 29.5 (724 x 749)
Effective Surface Area, ft ² (m ²)		24.1 (2.2)	24.1 (2.2)	24.1 (2.2)	24.1 (2.2)	24.1 (2.2)	24.1 (2.2)
Connection Sizes Liebert Challenger 3000 Unit							
Hot Gas Line, in.		5/8 OD Cu	7/8 OD Cu	N/A	N/A	N/A	N/A
Liquid Line, in.		3/8 OD Cu	1/2 OD Cu	Female Coupling #6	1/2 OD Cu	Female Coupling #6	1/2 OD Cu
Liquid Line Sweat Adapter (ID Cu-Coupler Size)		N/A	N/A	N/A	1/2 - Female Coupling #10	N/A	1/2 - Female Coupling #10
Suction Line, in.		N/A	N/A	Female Coupling #11	1-1/8 OD Cu	Female Coupling #11	1-1/8 OD Cu
Suction Line Sweat Adapter (ID Cu-Coupler Size)		N/A	N/A	N/A	1-1/8 - Female Coupling #12	N/A	1-1/8 - Female Coupling #12
Humidifier Supply Line, in.		1/4 OD Cu	1/4 OD Cu	1/4 OD Cu	1/4 OD Cu	1/4 OD Cu	1/4 OD Cu
Condensate Drain Line, in.		3/4 FPT	3/4 FPT	3/4 FPT	3/4 FPT	3/4 FPT	3/4 FPT
Condenser or Condensing Unit, Air-Cooled 95°F (35°C) Ambient							
Model		MCS028 or ---- 083	MCS028 or ---- 104	PFH042AL	PFH067AL	MC_40A	MC_65A
External Static, in. WG (Pa)		N/A	N/A	N/A	N/A	0.5 (125)	0.5 (125)
Hot Gas Connection		7/8 OD Cu	MCS028: 7/8 OD Cu ---- 104: 1-1/8 OD Cu	N/A	N/A	N/A	N/A
Liquid Line Connection		5/8 OD Cu	5/8 OD Cu	Male Coupling #6	Male Coupling #10	Male Coupling #6	Male Coupling #10
Suction Line Connection		N/A	N/A	Male Coupling #11	Male Coupling #12	Male Coupling #11	Male Coupling #12

11.0 AIR-COOLED DATA—50HZ

Table 3 Air-cooled data—50Hz

System Type BF = Downflow BU = Upflow	Self-Contained (Indoor Standard / Digital Compressor)		Split Systems - Standard Scroll Compressor			
			w/Outdoor Prop-Fan Condensing Unit		w/Indoor Centrifugal Condensing Unit	
Indoor Unit	BF/BU 040A	BF/BU 065A	BF/BU 035E	BF/BU 059E	BF/BU 035E	BF/BU 059E
* Net Capacity Data, Standard Air Volume	kW (BTU/H)	kW (BTU/H)	kW (BTU/H)	kW (BTU/H)	kW (BTU/H)	kW (BTU/H)
29°C DB, 18°C WB (85°F DB, 65°F WB) 33% RH						
Total	12.2 (41,700)	19.5 (66,500)	11.7 (39,900)	17.0 (57,900)	11.4 (38,900)	16.8 (57,500)
Sensible	12.1 (41,300)	19.5 (66,500)	11.7 (39,800)	16.9 (57,800)	11.4 (38,900)	16.8 (57,500)
27°C DB, 17.2°C WB (80°F DB, 63°F WB) 38% RH						
Total	11.4 (39,000)	18.3 (62,300)	11.1 (37,800)	16.1 (55,000)	10.8 (36,800)	16.0 (54,700)
Sensible	11.0 (37,700)	18.0 (61,400)	10.8 (36,900)	15.7 (53,500)	10.6 (36,200)	15.6 (53,300)
24°C DB, 16°C WB (75°F DB, 61°F WB) 45% RH						
Total	10.8 (36,700)	17.3 (58,900)	10.6 (36,100)	15.4 (52,700)	10.3 (35,100)	15.3 (52,300)
Sensible	9.8 (33,300)	15.9 (54,400)	9.7 (33,000)	14.0 (47,800)	9.5 (32,500)	13.9 (47,600)
* Net Capacity Data - Optional Air Volume						
29°C DB, 18°C WB (85°F DB, 65°F WB) 33% RH						
Total	N/A	19.7 (67,300)	N/A	17.0 (58,100)	N/A	16.9 (57,700)
Sensible	N/A	19.7 (67,300)	N/A	17.0 (58,100)	N/A	16.9 (57,700)
27°C DB, 17.2°C WB (80°F DB, 63°F WB) 38% RH						
Total	N/A	18.4 (62,800)	N/A	16.1 (55,000)	N/A	16.0 (54,600)
Sensible	N/A	18.3 (62,400)	N/A	15.9 (54,300)	N/A	15.8 (54,000)
24°C DB, 16°C WB (75°F DB, 61°F WB) 45% RH						
Total	N/A	17.3 (59,000)	N/A	15.4 (52,400)	N/A	15.3 (52,100)
Sensible	N/A	16.3 (55,700)	N/A	14.2 (48,600)	N/A	14.2 (48,400)
Fan Data (Blower A12x9AT) **						
Std. Air, CMH (CFM)	3060 (1800)	4420 (2600)	3060 (1800)	4420 (2600)	3060 (1800)	4420 (2600)
Std. Fan Motor, kW (hp)	0.75 (1)	1.5 (2)	0.75 (1)	1.5 (2)	0.75 (1)	1.5 (2)
Opt. Air, CMH (CFM)	N/A	4760 (2800)	N/A	4760 (2800)	N/A	4760 (2800)
Opt. Fan Motor, kW (hp)	N/A	1.5 (2)	N/A	1.5 (2)	N/A	1.5 (2)
External Static, Pa (in. WG)	75 (0.3)	75 (0.3)	75 (0.3)	75 (0.3)	75 (0.3)	75 (0.3)
Evaporator Coil (BF: A-Frame; BU: V-Frame)						
Face Area, m ² (ft. ²)	0.62 (6.67)	0.62 (6.67)	0.62 (6.67)	0.62 (6.67)	0.62 (6.67)	0.62 (6.67)
Rows	3	4	3	4	3	4
Face Velocity, m/s (FPM)	1.3 (255)	1.9 (375)	1.3 (255)	1.9 (375)	1.3 (255)	1.9 (375)
Electric Reheat 2 Stage (Stainless Steel, Fin Tubular) - Standard						
Capacity, kW (BTU/H) (including motor heat)	9 (34,100)	15 (56,200)	9 (34,100)	15 (56,200)	9 (34,100)	15 (56,200)
Hot Water Reheat 82.2°C (180°F) E.W.T., 23.9°C (75°F) E.A.T. - Optional (Inc. standard air volume and optional fan motor hp)						
Capacity, kW (BTU/H) (including motor heat)	20.9 (71,400)	25.3 (86,200)	20.9 (71,400)	25.3 (86,200)	20.9 (71,400)	25.3 (86,200)
Flow Rate, l/s (GPM)	.32 (5.0)	.32 (5.0)	.32 (5.0)	.32 (5.0)	.32 (5.0)	.32 (5.0)
Pressure drop, kPa (ft.)	50.4 (16.9)	50.4 (16.9)	50.4 (16.9)	50.4 (16.9)	50.4 (16.9)	50.4 (16.9)

* Capacity data is certified to ASHRAE 127-2007 standard. Fan motor heat has been subtracted, resulting in "net" capacity.

** Airflow data rated with 2" MERV 8 filter, rated per ASHRAE 52.2-2007. Some options or combinations of options may result in reduced airflow. Consult factory for recommendations.

Table 3 Air-cooled data—50Hz (continued)

System Type BF = Downflow BU = Upflow	Self-Contained (Indoor Standard / Digital Compressor)		Split Systems - Standard Scroll Compressor			
			w/Outdoor Prop-Fan Condensing Unit		w/Indoor Centrifugal Condensing Unit	
Indoor Unit	BF/BU 040A	BF/BU 065A	BF/BU 035E	BF/BU 059E	BF/BU 035E	BF/BU 059E
* Net Capacity Data, Standard Air Volume	kW (BTU/H)	kW (BTU/H)	kW (BTU/H)	kW (BTU/H)	kW (BTU/H)	kW (BTU/H)
Infrared Humidifier - Standard						
Capacity, kg/hr (lb/hr)	5 (11)	5 (11)	5 (11)	5 (11)	5 (11)	5 (11)
kW	4.8	4.8	4.8	4.8	4.8	4.8
Steam Generating Humidifier - Optional						
Capacity, kg/hr (lb/hr)	5 (11)	5 (11)	5 (11)	5 (11)	5 (11)	5 (11)
kW	3.9	3.9	3.9	3.9	3.9	3.9
Filter Section - MERV rating per ASHRAE 52.2-2007 - Deep Pleated Disposable Type Standard 51mm (2") MERV 8, or Optional 102mm (4") MERV 8 or MERV 11; 51mm (2") MERV 8 pre-filter available						
Nominal Size, mm (in.)	724 x 749 28.5 x 29.5	724 x 749 28.5 x 29.5	724 x 749 28.5 x 29.5	724 x 749 28.5 x 29.5	724 x 749 28.5 x 29.5	724 x 749 28.5 x 29.5
Effective Surface Area, m ² (ft ²)	2.2 (24.1)	2.2 (24.1)	2.2 (24.1)	2.2 (24.1)	2.2 (24.1)	2.2 (24.1)
Connection Sizes Liebert Challenger 3000 Unit						
Hot Gas Line, in.	5/8 OD Cu	7/8 OD Cu	N/A	N/A	N/A	N/A
Liquid Line, in.	3/8 OD Cu	1/2 OD Cu	Female Coupling #6	1/2 OD Cu	Female Coupling #6	1/2 OD Cu
Liquid Line Sweat Adapter (ID Cu- Coupler Size)	N/A	N/A	N/A	1/2 - Female Coupling #10	N/A	1/2 - Female Coupling #10
Suction Line, in.	N/A	N/A	Female Coupling #11	1-1/8 OD Cu	Female Coupling #11	1-1/8 OD Cu
Suction Line Sweat Adapter (ID Cu-Coupler Size)	N/A	N/A	N/A	1-1/8 - Female Coupling #12	N/A	1-1/8 - Female Coupling #12
Humidifier Supply Line, in.	1/4 OD Cu	1/4 OD Cu	1/4 OD Cu	1/4 OD Cu	1/4 OD Cu	1/4 OD Cu
Condensate Drain Line, in.	3/4 FPT	3/4 FPT	3/4 FPT	3/4 FPT	3/4 FPT	3/4 FPT
Condenser or Condensing Unit, Air-Cooled 35°C (95°F) Ambient						
Model	___ 083	___ 104	PFH41AL	PFH066AL	MC_39A	MC_64A
External Static, Pa (in. WG)	N/A	N/A	N/A	N/A	125 (0.5)	125 (0.5)
Hot Gas Connection	7/8 OD Cu	1-1/8 OD Cu	N/A	N/A	N/A	N/A
Liquid Line Connection	5/8 OD Cu	5/8 OD Cu	Male Coupling #6	Male Coupling #10	Male Coupling #6	Male Coupling #10
Suction Line Connection	N/A	N/A	Male Coupling #11	Male Coupling #12	Male Coupling #11	Male Coupling #12

12.0 WATER-COOLED DATA—60Hz

Table 4 Water-cooled data, 60Hz

System Type	BF = Downflow BU = Upflow	Self-Contained (Indoor Standard / Digital Compressor)		Split Systems (Standard Scroll Compressor)	
		BF/BU 046WG	BF/BU 071WG	BF/BU 036E	BF/BU 060E
Indoor Unit					
* Net Capacity Data - Standard Air Volume		BTU/H (kW)	BTU/H (kW)	BTU/H (kW)	BTU/H (kW)
85°F DB, 65°F WB (29°C DB, 18°C WB) 33% RH					
Total		47,500 (13.9)	81,100 (23.8)	45,100 (13.2)	79,300 (23.2)
Sensible		45,600 (13.4)	81,000 (23.7)	45,100 (13.2)	79,300 (23.2)
80°F DB, 63°F WB (27°C DB, 17.2°C WB) 38% RH					
Total		45,400 (13.3)	76,800 (22.5)	43,100 (12.6)	75,100 (22.0)
Sensible		41,300 (12.1)	73,900 (21.7)	42,600 (12.5)	73,800 (21.6)
75°F DB, 61°F WB (24°C DB, 16°C WB) 45% RH					
Total		43,500 (12.7)	72,900 (21.4)	41,300 (12.1)	71,300 (20.9)
Sensible		36,800 (10.8)	66,000 (19.3)	38,600 (11.3)	65,600 (19.2)
* Net Capacity Data - Optional Air Volume					
85°F DB, 65°F WB (29°C DB, 18°C WB) 33% RH					
Total		49,100 (14.4)	82,400 (24.1)	46,600 (13.7)	80,600 (23.6)
Sensible		48,900 (14.3)	82,400 (24.1)	46,600 (13.7)	80,600 (23.6)
80°F DB, 63°F WB (27°C DB, 17.2°C WB) 38% RH					
Total		46,400 (13.6)	77,400 (22.7)	44,100 (12.9)	75,700 (22.2)
Sensible		45,000 (13.2)	75,700 (22.2)	44,100 (12.9)	75,300 (22.1)
75°F DB, 61°F WB (24°C DB, 16°C WB) 45% RH					
Total		44,200 (13.0)	73,300 (21.5)	42,000 (12.3)	71,700 (21.0)
Sensible		40,000 (11.7)	67,800 (19.9)	41,500 (12.2)	67,200 (19.7)
Fan Data (Blower A12x9AT)**					
Std. Air, CFM (CMH)		1800 (3060)	2800 (4760)	1800 (3060)	2800 (4760)
Std. Fan Motor, hp (kW)		0.75 (0.56)	2 (1.5)	0.75 (0.56)	2 (1.5)
Opt. Air, CFM (CMH)		2300 (3910)	3000 (5100)	2300 (3910)	3000 (5100)
Opt. Fan Motor, hp (kW)		1 (0.75)	2 (1.5)	1 (0.75)	2 (1.5)
External Static, in. WG (Pa)		0.3 (75)	0.3 (75)	0.3 (75)	0.3 (75)
Evaporator Coil (BF: A-Frame; BU: V-Frame)					
Face Area, ft. ² (m ²)		6.67 (0.62)	6.67 (0.62)	6.67 (0.62)	6.67 (0.62)
Rows		3	4	3	4
Face Velocity, FPM (m/s)		255 (1.3)	405 (2.1)	255 (1.3)	405 (2.1)
Electric Reheat 2 Stage (Stainless Steel, Fin Tubular) - Standard					
Capacity, BTU/H (kW) (including motor heat)		33,400 (9)	56,200 (15)	33,400 (9)	56,200 (15)
Hot Water Reheat 180°F (82.2°C) E.W.T., 75°F (23.9°C) E.A.T. - Optional (Includes standard air volume & optional fan motor hp)					
Capacity, BTU/H (kW) (including motor heat)		71,400 (20.9)	88,700 (26.0)	71,400 (20.9)	88,700 (26.0)
Flow Rate, GPM (l/s)		5.0 (0.32)	5.0 (0.32)	5.0 (0.32)	5.0 (0.32)
Pressure Drop, ft. (kPa)		16.9 (50.4)	16.9 (50.4)	16.9 (50.4)	16.9 (50.4)
Hot Gas Reheat - Optional (Includes standard air volume & optional fan motor)					
Capacity, BTU/H (kW), (including motor heat)		42,600 (12.5)	54,900 (16.1)	42,600 (12.5)	54,900 (16.1)

* Capacity data is certified to ASHRAE 127-2007 standard. Fan motor heat has been subtracted, resulting in "net" capacity.

** Airflow data rated with 2" MERV 8 filter, rated per ASHRAE 52.2-2007. Some options or combinations of options may result in reduced airflow. Consult factory for recommendations.

Table 4 Water-cooled data, 60Hz (continued)

System Type	BF = Downflow BU = Upflow	Self-Contained (Indoor Standard / Digital Compressor)		Split Systems (Standard Scroll Compressor)	
		BF/BU 046WG	BF/BU 071WG	BF/BU 036E	BF/BU 060E
Indoor Unit					
* Net Capacity Data - Standard Air Volume		BTU/H (kW)	BTU/H (kW)	BTU/H (kW)	BTU/H (kW)
Infrared Humidifier - Standard					
Capacity, lb./hr (kg/hr)		11 (5)	11 (5)	11 (5)	11 (5)
kW		4.8	4.8	4.8	4.8
Steam Generating Humidifier - Optional					
Capacity, lb./hr (kg/hr)		11 (5)	11 (5)	11 (5)	11 (5)
kW		3.9	3.9	3.9	3.9
Filter Section - MERV rating per ASHRAE 52.2-2007 - Deep Pleated Disposable Type					
Standard 2" (51mm) MERV 8 or Optional 4" (102mm) MERV 8 or MERV 11; 2" (51mm) MERV 8 pre-filter available					
Nominal Size, in. (mm)		28.5 x 29.5 (724 x 749)	28.5 x 29.5 (724 x 749)	28.5 x 29.5 (724 x 749)	28.5 x 29.5 (724 x 749)
Effective Surface Area, ft ² (m ²)		24.1 (2.2)	24.1 (2.2)	24.1 (2.2)	24.1 (2.2)
Water Valve					
Water Regulating Valve (with Standard Scroll), Size, in.		3/4	1	3/4	1
Motorized Ball Valve (with Digital Scroll), Size, in.		1	1	—	—
Water Requirements, Coaxial Condenser		Internal	Internal	MC_44W	MC_69W
THR, BTU/H (kW) @ 75°F (22.2°C), 45% RH		51,000 (14.9)	82,000 (24.0)	50,500 (14.8)	81100 (23.8)
65°F (18.3°C) EWT - 105°F (40.6°C) Condensing Temperature					
Flow Rate, GPM (l/s)		2.1 (0.13)	5.7 (0.36)	2.0 (0.13)	5.7 (0.36)
Pressure Drop, PSI (kPa)		0.3 (2.2)	1.0 (7.0)	0.3 (2.1)	1.3 (9.3)
75°F (23.9°C) EWT - 105°F (40.6°C) Condensing Temp					
Flow Rate, GPM (l/s)		3.9 (0.25)	8.2 (0.52)	3.7 (0.24)	8.1 (0.51)
Pressure Drop, PSI (kPa)		0.9 (6.0)	1.8 (12.5)	1.0 (7.0)	2.5 (17.1)
85°F (29.4°C) EWT - 110°F (43.3°C) Condensing Temp					
Flow Rate, GPM (l/s)		5.6 (0.35)	10.5 (0.66)	5.4 (0.34)	10.3 (0.65)
Pressure Drop, PSI (kPa)		1.6 (11.2)	2.8 (19.5)	1.9 (13.4)	3.9 (27.1)
Connection Sizes—Liebert Challenger 3000 Unit					
Condenser Water Supply, in.		7/8 OD Cu	1-1/8 OD Cu	—	—
Condenser Water Return, in.		7/8 OD Cu	1-1/8 OD Cu	—	—
Liquid Line		—	—	Female Coupling #6	1/2 OD Cu
Liquid Line Sweat Adapter (ID Cu-Coupler Size)		N/A	N/A	N/A	1/2 - Female Coupling #10
Suction Line		—	—	Female Coupling #11	1-1/8 OD Cu
Suction Line Sweat Adapter (ID Cu-Coupler Size)		N/A	N/A	N/A	1-1/8 - Female Coupling #12
Humidifier Supply Line, in.		1/4 OD Cu	1/4 OD Cu	1/4 OD Cu	1/4 OD Cu
Condensate Drain Line, in.		3/4 FPT	3/4 FPT	3/4 FPT	3/4 FPT
Connection Sizes—Condensing Unit					
Condenser Water Supply, in.		—	—	7/8 OD Cu	1-1/8 OD Cu
Condenser Water Return, in.		—	—	7/8 OD Cu	1-1/8 OD Cu
Liquid Line, in.		—	—	Male Coupling #6	Male Coupling #10
Suction Line, in.		—	—	Male Coupling #11	Male Coupling #12

1. Self-contained unit pressure drops based on two-way valve with bypass. Split system unit pressure drops based on two-way or three-way valve.

13.0 WATER-COOLED DATA—50HZ

Table 5 Water-cooled data, 50Hz

System Type	BF = Downflow BU = Upflow	Self-Contained (Indoor Standard / Digital Compressor)		Split Systems (Standard Scroll Compressor)	
		BF/BU 045WG	BF/BU 070WG	BF/BU 035E	BF/BU 059E
Indoor Unit					
* Net Capacity Data - Standard Air Volume		kW (BTU/H)	kW (BTU/H)	kW (BTU/H)	kW (BTU/H)
29°C DB, 18°C WB (85°F DB, 65°F WB) 33% RH					
Total		13.0 (44,300)	23.4 (80,000)	12.2 (41,800)	20.5 (69,900)
Sensible		12.7 (43,500)	23.1 (78,700)	12.2 (41,800)	20.5 (69,900)
27°C DB, 17.2°C WB (80°F DB, 63°F WB) 38% RH					
Total		12.2 (41,700)	22.2 (75,600)	11.5 (39,400)	19.3 (66,000)
Sensible		11.5 (39,300)	21.0 (71,600)	11.4 (38,800)	18.8 (64,300)
24°C DB, 16°C WB (75°F DB, 61°F WB) 45% RH					
Total		11.5 (39,300)	21.0 (71,800)	10.9 (37,100)	18.4 (62,700)
Sensible		10.2 (34,700)	18.6 (63,600)	10.1 (34,400)	16.7 (57,100)
* Net Capacity Data - Optional Air Volume					
29°C DB, 18°C WB (85°F DB, 65°F WB) 33% RH					
Total		N/A	23.8 (81,300)	N/A	20.8 (71,000)
Sensible		N/A	23.8 (81,200)	N/A	20.8 (71,000)
27°C DB, 17.2°C WB (80°F DB, 63°F WB) 38% RH					
Total		N/A	22.5 (76,700)	N/A	19.6 (67,000)
Sensible		N/A	21.6 (73,800)	N/A	19.4 (66,300)
24°C DB, 16°C WB (75°F DB, 61°F WB) 45% RH					
Total		N/A	21.2 (72,400)	N/A	18.5 (63,200)
Sensible		N/A	19.2 (65,700)	N/A	17.2 (58,700)
Fan Data (Blower A12x9AT)**					
Std. Air, CMH (CFM)		3060 (1800)	4420 (2600)	3060 (1800)	4420 (2600)
Std. Fan Motor, kW (hp)		0.75 (1)	1.5 (2)	0.75 (1)	1.5 (2)
Opt. Air, CMH (CFM)		N/A	4760 (2800)	N/A	4760 (2800)
Opt. Fan Motor, kW (hp)		N/A	1.5 (2)	N/A	1.5 (2)
External Static, Pa. (in. WG)		75 (0.3)	75 (0.3)	75 (0.3)	75 (0.3)
Evaporator Coil (BF: A-Frame; BU: V-Frame)					
Face Area, m ² (ft. ²)		0.62 (6.67)	0.62 (6.67)	0.62 (6.67)	0.62 (6.67)
Rows		3	4	3	4
Face Velocity, m/s (FPM)		1.3 (255)	1.9 (375)	1.3 (255)	1.9 (375)
Electric Reheat 2 Stage (Stainless Steel, Fin Tubular) - Standard					
Capacity, kW (BTU/H) (including motor heat)		9 (34,100)	15 (56,200)	9 (34,100)	15 (56,200)
Hot Water Reheat 82.2°C (180°F) E.W.T., 23.9°C (75°F) E.A.T. - Optional (Includes standard air volume and optional fan motor hp)					
Capacity, kW (BTU/H) (including motor heat)		20.9 (71,400)	25.3 (86,200)	20.9 (71,400)	25.3 (86,200)
Flow Rate, l/s (GPM)		0.32 (5.0)	0.32 (5.0)	0.32 (5.0)	0.32 (5.0)
Pressure Drop, kPa (ft.)		50.4 (16.9)	50.4 (16.9)	50.4 (16.9)	50.4 (16.9)
Hot Gas Reheat - Optional (Includes standard air volume & optional fan motor)					
Capacity, kW (BTU/H) (including motor heat)		12.5 (42,600)	15.0 (51,300)	12.5 (42,600)	15.0 (51,300)

* Capacity data is certified to ASHRAE 127-2007 standard. Fan motor heat has been subtracted, resulting in "net" capacity.

** Airflow data rated with 2" MERV 8 filter, rated per ASHRAE 52.2-2007. Some options or combinations of options may result in reduced airflow. Consult factory for recommendations.

Table 5 Water-cooled data, 50Hz (continued)

System Type	BF = Downflow BU = Upflow	Self-Contained (Indoor Standard / Digital Compressor)		Split Systems (Standard Scroll Compressor)	
Indoor Unit		BF/BU 045WG	BF/BU 070WG	BF/BU 035E	BF/BU 059E
* Net Capacity Data - Standard Air Volume		kW (BTU/H)	kW (BTU/H)	kW (BTU/H)	kW (BTU/H)
Infrared Humidifier - Standard					
Capacity, kg/hr (lb/hr)		5 (11)	5 (11)	5 (11)	5 (11)
kW		4.8	4.8	4.8	4.8
Steam Generating Humidifier - Optional					
Capacity, kg/hr (lb/hr)		5 (11)	5 (11)	5 (11)	5 (11)
kW		3.9	3.9	3.9	3.9
Filter Section - MERV rating per ASHRAE 52.2-2007 - Deep Pleated Disposable Type					
Standard 51mm (2") MERV 8 or Optional 102mm (4") MERV 8 or MERV 11; 51mm (2") MERV 8 pre-filter available					
Nominal Size, mm (in.)		724 x 749 (28.5 x 29.5)	724 x 749 (28.5 x 29.5)	724 x 749 (28.5 x 29.5)	724 x 749 (28.5 x 29.5)
Effective Surface Area, m ² (ft ²)		2.2 (24.1)	2.2 (24.1)	2.2 (24.1)	2.2 (24.1)
Water Valve					
Water Regulating Valve (with Standard Scroll), Size, in.		3/4	1	3/4	1
Motorized Ball Valve (with Digital Scroll), Size, in.		1	1	—	—
Water Requirements (Coaxial Condenser)		Internal	Internal	MC_43W	MC_68W
THR - kW (BTU/H) @ 22.2°C (75°F), 45% RH		15.4 (52,400)	23.8 (81,200)	15.0 (51100)	23.2 (79,200)
18.3°C (65°F) EWT - 40.6°C (105°F) Condensing Temperature					
Flow Rate, l/s (GPM)		0.13 (2.0)	0.36 (5.7)	0.12 (1.8)	0.31 (5.0)
Pressure Drop, kPa (PSI)		1.8 (0.3)	6.2 (0.9)	2.0 (0.3)	7.0 (1.0)
23.9°F (75°F) EWT - 40.6°C (105°F) Condensing Temperature					
Flow Rate, l/s (GPM)		0.24 (3.7)	0.51 (8.1)	0.22 (3.5)	0.45 (7.1)
Pressure Drop, kPa (PSI)		5.4 (0.8)	12.4 (1.8)	6.4 (0.9)	13.3 (1.9)
29.4°C (85°F) EWT - 43.3°C (110°F) Condensing Temperature					
Flow Rate, l/s (GPM)		0.33 (5.3)	0.65 (10.3)	0.31 (5.0)	0.57 (9.0)
Pressure Drop, kPa (PSI)		9.6 (1.4)	18.6 (2.7)	11.7 (1.7)	21.0 (3.0)
Connection Sizes—Liebert Challenger 3000 Unit					
Condenser Water Supply, in.		7/8 OD Cu	1-1/8 OD Cu	—	—
Condenser Water Return, in.		7/8 OD Cu	1-1/8 OD Cu	—	—
Liquid Line		—	—	Female Coupling #6	1/2 OD Cu
Liquid Line Sweat Adapter (ID Cu-Coupler Size)		N/A	N/A	N/A	1/2 - Female Coupling #10
Suction Line		—	—	Female Coupling #11	1-1/8 OD Cu
Suction Line Sweat Adapter (ID Cu-Coupler Size)		N/A	N/A	N/A	1-1/8 - Female Coupling #12
Humidifier Supply Line, in.		1/4 OD Cu	1/4 OD Cu	1/4 OD Cu	1/4 OD Cu
Condensate Drain Line, in.		3/4 FPT	3/4 FPT	3/4 FPT	3/4 FPT
Connection Sizes—Condensing Unit					
Condenser Water Supply, in.		—	—	7/8 OD Cu	1-1/8 OD Cu
Condenser Water Return, in.		—	—	7/8 OD Cu	1-1/8 OD Cu
Liquid Line, in.		—	—	Male Coupling #6	Male Coupling #10
Suction Line, in.		—	—	Male Coupling #11	Male Coupling #12

1. Self-contained unit pressure drops based on two-way valve with bypass. Split system unit pressure drops based on two-way or three-way valve.

14.0 GLYCOL-COOLED DATA—60HZ

Table 6 Glycol-cooled data, 60Hz

System Type BF or BE = Downflow BU or BK = Upflow	Glycol Cooled			
	Self-Contained (Indoor Standard / Digital Compressor)		Split Systems (Standard Scroll Compressor)	
Indoor Unit	BF/BU 046WG	BF/BU 071WG	BF/BU 036E	BF/BU 060E
* Net Capacity Data - Std Air Volume	BTU/H (kW)	BTU/H (kW)	BTU/H (kW)	BTU/H (kW)
85°F DB, 65°F WB (29°C DB, 18°C WB) 33% RH				
Total	42,200 (12.4)	69,500 (20.4)	40,100 (11.7)	68,000 (19.9)
Sensible	41,900 (12.3)	69,500 (20.4)	40,100 (11.7)	68,000 (19.9)
80°F DB, 63°F WB (27°C DB, 17.2°C WB) 38% RH				
Total	40,000 (11.7)	64,800 (19.0)	38,000 (11.1)	63,400 (18.6)
Sensible	38,200 (11.2)	64,800 (19.0)	37,500 (11.0)	62,300 (18.3)
75°F DB, 61°F WB (24°C DB, 16°C WB) 45% RH				
Total	38,200 (11.2)	60,600 (17.8)	36,300 (10.6)	59,300 (17.4)
Sensible	34,000 (10.0)	59,000 (17.3)	33,900 (9.9)	54,500 (16.0)
* Net Capacity Data - Optional Air Volume				
85°F DB, 65°F WB (29°C DB, 18°C WB) 33% RH				
Total	43,800 (12.8)	70,400 (20.6)	41,600 (12.2)	68,900 (20.2)
Sensible	43,800 (12.8)	70,400 (20.6)	41,600 (12.2)	68,900 (20.2)
80°F DB, 63°F WB (27°C DB, 17.2°C WB) 38% RH				
Total	40,900 (12.0)	65,400 (19.2)	38,900 (11.4)	64,000 (18.8)
Sensible	40,800 (12.0)	65,400 (19.2)	38,900 (11.4)	63,700 (18.7)
75°F DB, 61°F WB (24°C DB, 16°C WB) 45% RH				
Total	38,600 (11.3)	60,700 (17.8)	36,700 (10.8)	59,400 (17.4)
Sensible	36,800 (10.8)	60,100 (17.6)	36,200 (10.6)	55,700 (16.3)
Fan Data (Blower A12x9AT)**				
Std. Air, CFM (CMH)	1800 (3060)	2800 (4760)	1800 (3060)	2800 (4760)
Std. Fan Motor, hp (kW)	0.75 (0.56)	2 (1.5)	0.75 (0.56)	2 (1.5)
Opt. Air, CFM (CMH)	2300 (3910)	3000 (5100)	2300 (3910)	3000 (5100)
Opt Fan Motor, hp (kW)	1 (0.75)	2 (1.5)	1 (0.75)	2 (1.5)
External Static, in. WG (Pa)	0.3 (75)	0.3 (75)	0.3 (75)	0.3 (75)
Evaporator Coil (BF: A-Frame; BU: V-Frame)				
Face Area, ft. ² (m ²)	6.67 0 (0.62)	6.67 0 (0.62)	6.67 0 (0.62)	6.67 0 (0.62)
Rows	3	4	3	4
Face Velocity, FPM (m/s)	255 (1.3)	405 (2.1)	255 (1.3)	405 (2.1)
Electric Reheat 2 Stage (Stainless Steel, Fin Tubular) - Standard				
Capacity, BTU/H (kW) (including motor heat)	33,400 (9)	56,200 (15)	33,400 (9)	56,200 (15)
Hot Water Reheat 180°F (82.2°C) E.W.T., 75°F (23.9°C) E.A.T. - Optional (Includes standard air volume & optional fan motor hp)				
Capacity, BTU/H (kW) (including motor heat)	71,400 (20.9)	88,700 (26.0)	71,400 (20.9)	88,700 (26.0)
Flow Rate, GPM (l/s)	5.0 (0.32)	5.0 (0.32)	5.0 (0.32)	5.0 (0.32)
Pressure Drop, ft. (kPa)	16.9 (50.4)	16.9 (50.4)	16.9 (50.4)	16.9 (50.4)
Hot Gas Reheat - Optional (Includes standard air volume & optional fan motor)				
Capacity, BTU/H (kW) (including motor heat)	42,600 (12.5)	54,900 (16.1)	42,600 (12.5)	54,900 (16.1)

* Capacity data is certified to ASHRAE 127-2007 standard. Fan motor heat has been subtracted, resulting in net capacity.

** Airflow data rated with 2" MERV 8 filter, rated per ASHRAE 52.2-2007. Some options or combinations of options may result in reduced airflow. Consult factory for recommendations.

Table 6 Glycol-cooled data, 60Hz (continued)

System Type BF or BE = Downflow BU or BK = Upflow	Glycol Cooled			
	Self-Contained (Indoor Standard / Digital Compressor)		Split Systems (Standard Scroll Compressor)	
Indoor Unit	BF/BU 046WG	BF/BU 071WG	BF/BU 036E	BF/BU 060E
* Net Capacity Data - Std Air Volume	BTU/H (kW)	BTU/H (kW)	BTU/H (kW)	BTU/H (kW)
Infrared Humidifier, Standard				
Capacity, lb/hr (kg/hr)	11 (5)	11 (5)	11 (5)	11 (5)
kW	4.8	4.8	4.8	4.8
Steam Generating Humidifier - Optional				
Capacity, lb/hr (kg/hr)	11 (5)	11 (5)	11 (5)	11 (5)
kW	3.9	3.9	3.9	3.9
Filter Section - MERV rating per ASHRAE 52.2-2007 - Deep Pleated Disposable Type Standard 2" (51mm) MERV 8 or Optional 4" (102mm) MERV 8 or MERV 11; 2" (51"mm) MERV 8 pre-filter available				
Nominal Size, in (mm)	28.5 x 29.5 (724 x 749)	28.5 x 29.5 (724 x 749)	28.5 x 29.5 (724 x 749)	28.5 x 29.5 (724 x 749)
Effective Surface Area, ft ² (m ²)	24.1 (2.2)	24.1 (2.2)	24.1 (2.2)	24.1 (2.2)
Glycol Valve				
Water Regulating Valve (with Standard Scroll), Size, in.	3/4	1	3/4	1
Motorized Ball Valve (with Digital Scroll), Size, in.	1	1	—	—
Glycol Requirement (Coaxial Condenser)				
Flow Rate, GPM (l/s)	10.5 (.66)	18.1 (1.14)	11.4 (.72)	20.7 (1.31)
Unit Volume, gal (l)	1.2 (4.5)	2.0 (7.5)	1.2 (4.5)	2.0 (7.5)
Pressure Drop, ft. (kPa)	16.0 (47.7)	20.9 (62.3)	23.4 (69.8)	41.4 (123.3)
Connection Sizes—Liebert Challenger 3000 Unit				
Condenser Glycol Supply, in.	7/8 OD Cu	1-1/8 OD Cu	—	—
Condenser Glycol Return, in.	7/8 OD Cu	1-1/8 OD Cu	—	—
Liquid Line	—	—	Female Coupling #6	1/2 OD Cu
Liquid Line Sweat Adapter (ID Cu-Coupler Size)	N/A	N/A	N/A	1/2 - Female Coupling #10
Suction Line	—	—	Female Coupling #11	1-1/8 OD Cu
Suction Line Sweat Adapter (ID Cu-Coupler Size)	N/A	N/A	N/A	1-1/8 - Female Coupling #12
Humidifier Supply Line, in.	1/4 OD Cu	1/4 OD Cu	1/4 OD Cu	1/4 OD Cu
Condensate Drain Line, in.	3/4 FPT	3/4 FPT	3/4 FPT	3/4 FPT
Connection Sizes—Condensing Unit				
Condenser Glycol Supply, in.	—	—	7/8 OD Cu	1-1/8 OD Cu
Condenser Glycol Return, in.	—	—	7/8 OD Cu	1-1/8 OD Cu
Liquid Line, in.	—	—	Male Coupling #6	Male Coupling #10
Suction Line, in.	—	—	Male Coupling #11	Male Coupling #12
Drycooler 95°F (35°C) Ambient *				
Model Number	DSF092-3PH	DSF109-3PH	DSF092-3PH	DSF109-3PH
Drycooler Connections, OD Cu	1-5/8	1-3/8	1-5/8	1-3/8
Volume, gal (l)	3.7 (13.9)	4.9 (18.6)	3.7 (13.9)	4.9 (18.6)
Fan, hp (kW)	0.75 (0.56)	0.75 (0.56)	0.75 (0.56)	0.75 (0.56)
Expansion Tank Capacity, gal (l)	8.8 (33.1)	8.8 (33.1)	8.8 (33.1)	8.8 (33.1)
Glycol Pump, 3-Phase hp (kW)	1.5 (1.1)	2.0 (1.5)	0.75 (0.56)	1.5 (1.1)

* All data above is based on 40% propylene glycol solution.

15.0 GLYCOL-COOLED DATA—50Hz

Table 7 Glycol-cooled data, 50Hz

System Type BF or BE = Downflow BU or BK = Upflow	Glycol Cooled			
	Self-Contained (Indoor Standard / Digital Compressor)		Split Systems (Standard Scroll Compressor)	
Indoor Unit	BF/BU 045WG	BF/BU 070WG	BF/BU 035E	BF/BU 059E
* Net Capacity Data - Std Air Volume	kW (BTU/H)	kW (BTU/H)	kW (BTU/H)	kW (BTU/H)
29°C DB, 18°C WB (85°F DB, 65°F WB) 33% RH				
Total	11.7 (40,000)	20.0 (68,400)	11.1 (37,800)	17.5 (59,700)
Sensible	11.7 (39,900)	20.0 (68,400)	11.1 (37,800)	17.5 (59,700)
27°C DB, 17.2°C WB (80°F DB, 63°F WB) 38% RH				
Total	10.9 (37,100)	18.5 (63,300)	10.3 (35,000)	16.2 (55,300)
Sensible	10.7 (36,400)	18.5 (63,300)	10.1 (34,400)	15.8 (53,900)
24°C DB, 16°C WB (75°F DB, 61°F WB) 45% RH				
Total	10.1 (34,600)	17.3 (59,100)	9.6 (32,700)	15.1 (51,600)
Sensible	9.4 (32,200)	16.6 (56,800)	8.9 (30,300)	13.8 (47,000)
* Net Capacity Data - Optional Air Volume				
29°C DB, 18°C WB (85°F DB, 65°F WB) 33% RH				
Total	N/A	20.4 (69,700)	N/A	17.8 (60,900)
Sensible	N/A	20.4 (69,700)	N/A	17.8 (60,900)
27°C DB, 17.2°C WB (80°F DB, 63°F WB) 38% RH				
Total	N/A	18.9 (64,400)	N/A	16.5 (56,200)
Sensible	N/A	18.9 (64,400)	N/A	16.3 (55,600)
24°C DB, 16°C WB (75°F DB, 61°F WB) 45% RH				
Total	N/A	17.5 (59,600)	N/A	15.3 (52,100)
Sensible	N/A	17.1 (58,300)	N/A	14.2 (48,400)
Fan Data (Blower A12x9AT) **				
Std. Air, CMH (CFM)	3060 (1800)	4420 (2600)	3060 (1800)	4420 (2600)
Std. Fan Motor, kW (hp)	0.75 (1)	1.1 (1.5)	0.75 (1)	1.1 (1.5)
Opt. Air, CMH (CFM)	N/A	4760 (2800)	N/A	4760 (2800)
Opt. Fan Motor, kW (hp)	N/A	1.5 (2)	N/A	1.5 (2)
External Static, Pa (in. WG)	75 (0.3)	75 (0.3)	75 (0.3)	75 (0.3)
Evaporator Coil (BF: A-Frame; BU: V-Frame)				
Face Area, m ² (ft. ²)	0.62 (6.67)	0.62 (6.67)	0.62 (6.67)	0.62 (6.67)
Rows	3	4	3	4
Face Velocity, m/s (FPM)	1.3 (255)	1.9 (375)	1.3 (255)	1.9 (375)
Electric Reheat 2 Stage (Stainless Steel, Fin Tubular) - Standard				
Capacity, kW (BTU/H) (including motor heat)	9 (34,100)	15 (56,200)	9 (34,100)	15 (56,200)
Hot Water Reheat 82.2°C (180°F) E.W.T., 23.9°C (75°F) E.A.T. - Optional (Includes standard air volume and optional fan motor hp)				
Capacity, kW (BTU/H) (including motor heat)	20.9 (71,400)	25.3 (86,200)	20.9 (71,400)	25.3 (86,200)
Flow Rate, l/s (GPM)	0.32 (5.0)	0.32 (5.0)	0.32 (5.0)	0.32 (5.0)
Pressure drop, kPa (Ft.)	50.4 (16.9)	50.4 (16.9)	50.4 (16.9)	50.4 (16.9)
Hot Gas Reheat - Optional (Includes standard air volume and optional fan motor)				
Capacity, kW (BTU/H) (including motor heat)	12.5 (42,600)	15.0 (51,300)	12.5 (42,600)	15.0 (51,300)

* Capacity data is certified to ASHRAE 127-2007 standard. Fan motor heat has been subtracted, resulting in "net" capacity.

** Airflow data rated with 2" MERV 8 filter, rated per ASHRAE 52.2-2007. Some options or combinations of options may result in reduced airflow. Consult factory for recommendations.

Table 7 Glycol-cooled data, 50Hz (continued)

System Type BF or BE = Downflow BU or BK = Upflow	Glycol Cooled			
	Self-Contained (Indoor Standard / Digital Compressor)		Split Systems (Standard Scroll Compressor)	
Indoor Unit	BF/BU 045WG	BF/BU 070WG	BF/BU 035E	BF/BU 059E
* Net Capacity Data - Std Air Volume	kW (BTU/H)	kW (BTU/H)	kW (BTU/H)	kW (BTU/H)
Infrared Humidifier - Standard				
Capacity, kg/hr (lb/hr)	5 (11)	5 (11)	5 (11)	5 (11)
kW	4.8	4.8	4.8	4.8
Steam Generating Humidifier - Optional				
Capacity, kg/hr (lb/hr)	5 (11)	5 (11)	5 (11)	5 (11)
kW	3.9	3.9	3.9	3.9
Filter Section - MERV rating per ASHRAE 52.2-2007 - Deep Pleated Disposable Type Standard 51mm (2") MERV 8 or Optional 102mm (4") MERV 8 or MERV 11; 51mm (2") MERV 8 pre-filter available				
Nominal Size, mm (in.)	724 x 749 (28.5 x 29.5)	724 x 749 (28.5 x 29.5)	724 x 749 (28.5 x 29.5)	724 x 749 (28.5 x 29.5)
Effective Surface Area, m ² (ft ²)	2.2 (24.1)	2.2 (24.1)	2.2 (24.1)	2.2 (24.1)
Glycol Valve				
Water Regulating Valve (with Standard Scroll), Size, in.	3/4	1	3/4	1
Motorized Ball Valve (with Digital Scroll), Size, in.	1	1	—	—
Glycol Requirement (Coaxial Condenser)				
Flow Rate, l/s (gpm)	.60 (9.5)	1.2 (18.4)	.66 (10.5)	1.2 (18.7)
Unit Volume, liters (gal)	4.5 (1.2)	7.5 (2.0)	4.5 (1.2)	7.5 (2.0)
Pressure Drop, kPa (ft.)	39 (13.1)	64 (21.5)	59 (19.8)	101 (33.8)
Connection Sizes—Liebert Challenger 3000 Unit				
Condenser Glycol Supply, in.	7/8 OD Cu	1-1/8 OD Cu	—	—
Condenser Glycol Return, in.	7/8 OD Cu	1-1/8 OD Cu	—	—
Liquid Line	—	—	Female Coupling #6	1/2 OD Cu
Liquid Line Sweat Adapter (ID Cu-Coupler Size)	N/A	N/A	N/A	1/2 - Female Coupling #10
Suction Line	—	—	Female Coupling #11	1-1/8 OD Cu
Suction Line Sweat Adapter (ID Cu-Coupler Size)	N/A	N/A	N/A	1-1/8 - Female Coupling #12
Humidifier Supply Line, in.	1/4 OD Cu	1/4 OD Cu	1/4 OD Cu	1/4 OD Cu
Condensate Drain Line, in.	3/4 FPT	3/4 FPT	3/4 FPT	3/4 FPT
Connection Sizes—Condensing Unit				
Condenser Glycol Supply, in.	—	—	7/8 OD Cu	1-1/8 OD Cu
Condenser Glycol Return, in.	—	—	7/8 OD Cu	1-1/8 OD Cu
Liquid Line, in.	—	—	Male Coupling #6	Male Coupling #10
Suction Line, in.	—	—	Male Coupling #11	Male Coupling #12
Drycooler 35°C (95°F) Ambient *				
Model Number	DSF092-3 PH	DSF109-3PH	DSF092-3 PH	DSF109-3PH
Drycooler Connections, FPT	1-5/8	1-3/8	1-5/8	1-3/8
Volume, liters (gal)	13.9 (3.7)	18.6 (4.9)	13.9 (3.7)	18.6 (4.9)
Fan, kW (hp)	0.56 (0.75)	0.56 (0.75)	0.56 (0.75)	0.56 (0.75)
Expansion Tank Capacity, liters (gal)	33.1 (8.8)	33.1 (8.8)	33.1 (8.8)	33.1 (8.8)
Glycol Pump, 3-phase, kW (hp)	1.1 (1.5)	1.5 (2.0)	1.1 (1.5)	1.5 (2.0)

* All data above is based on 40% propylene glycol solution.

16.0 CHILLED WATER DATA—60Hz

Table 8 Chilled water data—60Hz

Capacity Data BTU/H (kW) @ 45°F (7.2°C) EWT * Net Capacity Data - Standard Air Volume			
Indoor Unit	BF = Downflow BU = Upflow	BF/BU 068C	BF/BU 102C
85°F DB, 65°F WB (29°C DB, 18°C WB) 33% RH			
Total, BTU/H (kW)		50,200 (14.7)	87,400 (25.6)
Sensible, BTU/H (kW)		50,200 (14.7)	85,300 (25.0)
Flow Rate, GPM (l/s)		10.3 (0.6)	18.4 (1.2)
Pressure Drop, ft (kPa)		6.6 (19.7)	22.4 (66.8)
80°F DB, 63°F WB (27°C DB, 17.2°C WB) 38% RH			
Total, BTU/H (kW)		41,600 (12.2)	73,000 (21.4)
Sensible, BTU/H (kW)		41,600 (12.2)	71,700 (21.0)
Flow Rate, GPM (l/s)		8.6 (0.5)	15.5 (1.0)
Pressure Drop, ft. (kPa)		4.8 (14.3)	16.4 (48.9)
75°F DB, 61°F WB (24°C DB, 16°C WB) 45% RH			
Total, BTU/H (kW)		33,300 (9.8)	59,000 (17.3)
Sensible, BTU/H (kW)		33,300 (9.8)	57,700 (16.9)
Flow Rate, GPM (l/s)		6.9 (0.4)	12.7 (0.8)
Pressure Drop, ft. (kPa)		3.2 (9.5)	11.4 (34.0)
* Net Capacity - Optional Air Volume			
85°F DB, 65°F WB (29°C DB, 18°C WB) 33% RH			
Total, BTU/H (kW)		58,700 (17.2)	90,800 (26.6)
Sensible, BTU/H (kW)		58,700 (17.2)	88,700 (26.0)
Flow Rate, GPM (l/s)		12.2 (0.8)	19.2 (1.2)
Pressure Drop, ft. (kPa)		9.1 (27.1)	24.4 (72.7)
80°F DB, 63°F WB (27°C DB, 17.2°C WB) 38% RH			
Total, BTU/H (kW)		48,800 (14.3)	75,100 (22.0)
Sensible, BTU/H (kW)		48,800 (14.3)	74,400 (21.8)
Flow Rate, GPM (l/s)		10.2 (0.6)	16.1 (1.0)
Pressure Drop, ft. (kPa)		6.5 (19.4)	17.7 (52.7)
75°F DB, 61°F WB (24°C DB, 16°C WB) 45% RH			
Total, BTU/H (kW)		38,200 (11.2)	60,800 (17.8)
Sensible, BTU/H (kW)		38,200 (11.2)	59,700 (17.5)
Flow Rate, GPM (l/s)		8.2 (0.5)	13.2 (0.8)
Pressure Drop, ft (kPa)		4.3 (12.8)	12.3 (36.7)
Indoor Unit			
	BF = Downflow BU = Upflow	BF/BU 068C	BF/BU 102C
Fan Data (Blower A12x9AT)**			
Std. Air, CFM (CMH)		1800 (3060)	2800 (4760)
Std. Fan Motor, hp (kW)		0.75 (0.56)	2 (1.5)
Opt. Air, CFM (CMH)		2300 (3910)	3000 (5100)
Opt. Fan Motor, hp (kW)		1 (0.75)	2 (1.5)
External Static, in. WG (Pa)		0.3 (75)	0.3 (75)
Chilled Water Coil (BF: A-Frame; BU: V-Frame)			
Face Area, ft. ² (m ²)		6.67 (0.62)	6.67 (0.62)
Rows		3	4
Face Velocity, FPM (m/s)		255 (1.3)	405 (2.1)
Electric Reheat 2 Stage (Stainless Steel, Fin Tubular) - Standard			
Capacity - BTU/H (kW) (incl. motor heat)		33,400 (9)	56,200 (15)
Hot Water Reheat 180°F (82.2°C) E.W.T., 75°F (23.9°C) E.A.T. - Optional (Includes standard air volume & optional fan motor hp)			
Capacity, BTU/H (kW) (incl. motor heat)		71,400 (20.9)	88,700 (26.0)
Flow Rate, GPM (l/s)		5.0 (.32)	5.0 (.32)
Pressure Drop, ft. (kPa)		16.9 (50.4)	16.9 (50.4)
Infrared Humidifier - Standard			
Capacity, lb/hr (kg/hr)		11 (5)	11 (5)
kW		4.8	4.8
Steam Generating Humidifier - Optional			
Capacity, lb/hr (kg/hr)		11 (5)	11 (5)
kW		3.9	3.9
Filter Section - MERV rating per ASHRAE 52.2-2007 - Deep Pleated Disposable Type Standard 2" (51mm) MERV 8 or Optional 4" (102mm) MERV 8 or MERV 11; 2" (51mm) MERV 8 pre-filter available			
Nominal Size, in (mm)		28.5 x 29.5 (724 x 749)	28.5 x 29.5 (724 x 749)
Effective Surface Area, ft ² (m ²)		24.1 (2.2)	24.1 (2.2)
Connection Sizes, Liebert Challenger 3000			
CW Supply, in.		1-1/8 OD Cu	1-1/8 OD Cu
CW Return, in.		1-1/8 OD Cu	1-1/8 OD Cu
Humidifier Supply, in.		1/4 OD Cu	1/4 OD Cu
Condensate Drain, in.		3/4 FPT	3/4 FPT
Control Valve			
Maximum Design Water Pressure 150 psi (1034.3 kPa)			
Valve Actuator		Modulating	Modulating
Sensors		Proportional	Proportional
Valve Body		3-Way	3-Way
Valve Size, in.		1	1
Cv		13.9	13.9
2-Way Valve (Optional)			
Close-Off Pressure, PSI (kPa)		70 (483)	70 (483)

* Capacity data is certified to ASHRAE 127-2007 standard. Fan motor heat has been subtracted, resulting in "net" capacity.

** Data rated with 2" MERV 8 filter. Some options or combinations of options may result in reduced airflow. Consult factory for recommendations.

17.0 CHILLED WATER DATA—50Hz

Table 9 Chilled water data—50Hz

Capacity Data, kW (BTU/H) @ 7.2°C (45°F) EWT, 5.6°C (10°F) Water Rise			
* Net Capacity Data - Standard Air Volume			
Indoor Unit BF = Downflow BU = Upflow	BF/BU 072C	BF/BU 101C	
29°C DB, 18°C WB (85°F DB, 65°F WB) 33% RH			
Total, kW (BTU/H)	14.7 (50200)	24.6 (84000)	
Sensible, kW (BTU/H)	14.7 (50200)	23.8 (81200)	
Flow Rate, l/s (GPM)	0.4 (6.9)	1.1 (17.5)	
Pressure Drop, kPa (ft)	19.4 (6.5)	61.1 (20.5)	
27°C DB, 17.2°C WB (80°F DB, 63°F WB) 38% RH			
Total, kW (BTU/H)	12.2 (41600)	20.5 (70000)	
Sensible, kW (BTU/H)	12.2 (41600)	20.0 (68300)	
Flow Rate, l/s (GPM)	0.5 (8.6)	0.9 (14.7)	
Pressure Drop, kPa (ft)	14.0 (4.7)	44.7 (15.0)	
24°C DB, 16°C WB (75°F DB, 61°F WB) 45% RH			
Total, kW (BTU/H)	9.8 (33400)	16.7 (57000)	
Sensible, kW (BTU/H)	9.8 (33400)	16.2 (55300)	
Flow Rate, l/s (GPM)	0.4 (6.9)	0.8 (12.1)	
Pressure Drop, kPa (ft)	9.2 (3.1)	31.0 (10.4)	
* Net Capacity - Optional Air Volume			
29°C DB, 18°C WB (85°F DB, 65°F WB) 33% RH			
Total, kW (BTU/H)	N/A	25.6 (87400)	
Sensible, kW (BTU/H)	N/A	24.9 (85000)	
Flow Rate, l/s (GPM)	N/A	1.2 (18.3)	
Pressure Drop, kPa (ft)	N/A	66.8 (22.4)	
27°C DB, 17.2°C WB (80°F DB, 63°F WB) 38% RH			
Total, kW (BTU/H)	N/A	21.3 (72700)	
Sensible, kW (BTU/H)	N/A	20.9 (71300)	
Flow Rate, l/s (GPM)	N/A	1.0 (15.4)	
Pressure Drop, kPa (ft)	N/A	48.6 (16.3)	
24°C DB, 16°C WB (75°F DB, 61°F WB) 45% RH			
Total, kW (BTU/H)	N/A	17.3 (59000)	
Sensible, kW (BTU/H)	N/A	16.8 (57300)	
Flow Rate, l/s (GPM)	N/A	0.8 (12.7)	
Pressure Drop, kPa (ft)	N/A	34.0 (11.4)	
* Capacity data is certified to ASHRAE 127-2007 standard. Fan motor heat has been subtracted, resulting in "net" capacity			
Indoor Unit BF = Downflow BU = Upflow	BF/BU 072C	BF/BU 101C	
Fan Data (Blower A12x9AT) **			
Std. Air, CMH (CFM)	3060 (1800)	4420 (2600)	
Std. Fan Motor, kW (hp)	.75 (1)	1.5 (2)	
Opt. Air, CMH (CFM)	N/A	4760 (2800)	
Opt. Fan Motor, kW (hp)	N/A	1.5 (2)	
External Static, Pa, (in. WG)	75 (.3)	75 (.3)	
Chilled Water Coil (BF: A-Frame; BU: V-Frame)			
Face Area, m ² (ft ²)	.62 (6.67)	.62 (6.67)	
Rows	3	4	
Face Velocity, m/s (FPM)	1.3 (255)	1.9 (375)	
Electric Reheat 2 Stage (Stainless Steel, Fin Tubular) - Standard			
Capacity, kW (BTU/H) (including motor heat)	9 (34,100)	15 (56,200)	
Hot Water Reheat 82.2°C (180°F) E.W.T., 23.9°C (75°F) E.A.T. - Optional (Includes standard air volume and optional fan motor hp)			
Capacity, BTU/H (kW) (including motor heat)	20.9 (71,400)	25.3 (86,200)	
Flow Rate, l/s (GPM)	.32 (5.0)	.32 (5.0)	
Pressure drop, kPa (ft.)	50.4 (16.9)	50.4 (16.9)	
Infrared Humidifier - Standard			
Capacity, kg/hr (lb/hr)	5 (11)	5 (11)	
kW	4.8	4.8	
Steam Generating Humidifier - Optional			
Capacity, kg/hr (lb/hr)	5 (11)	5 (11)	
kW	3.9	3.9	
Filter Section - MERV rating per ASHRAE 52.2-2007 - Deep Pleated Disposable Type Standard 51mm (2") MERV 8, or Optional 102mm (4") MERV 8 or MERV 11; 51mm (2") MERV 8 pre-filter available			
Nominal Size, mm (in.)	724 x 749 (28.5 x 29.5)	724 x 749 (28.5 x 29.5)	
Effective Surface Area, m ² (ft ²)	2.2 (24.1)	2.2 (24.1)	
Connection Sizes, Liebert Challenger 3000			
CW Supply, in.	1-1/8 OD Cu	1-1/8 OD Cu	
CW Return, in.	1-1/8 OD Cu	1-1/8 OD Cu	
Humidifier Supply, in.	1/4 OD Cu	1/4 OD Cu	
Condensate Drain, FPT	3/4	3/4	
Control Valve			
Maximum design water pressure 1034.4 kPa (150 PSI)			
Valve Actuator	Modulating	Modulating	
Sensors	Proportional	Proportional	
Valve Body	3-Way	3-Way	
Valve Size, in.	1	1	
Cv	13.9	13.9	
2-Way Valve (Optional)			
Close-Off Pressure, kPa (PSI)	483 (70)	483 (70)	

** Data rated with 2" MERV 8 filter. Some options or combinations of options may result in reduced airflow. Consult factory for recommendations.

18.0 DIMENSIONAL DRAWINGS

Figure 13 Cabinet and floor planning dimensions—Upflow (BU/BK) models

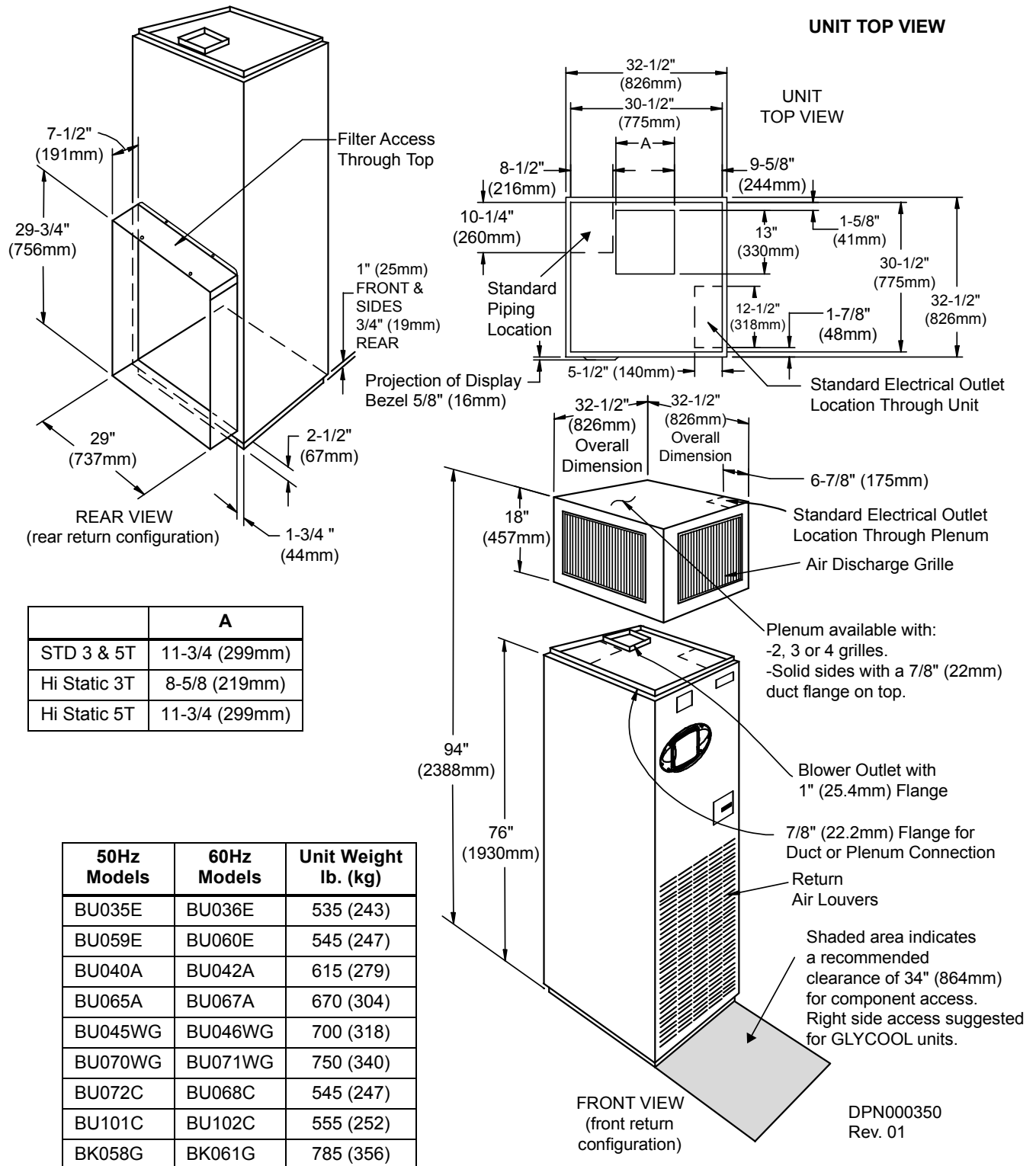
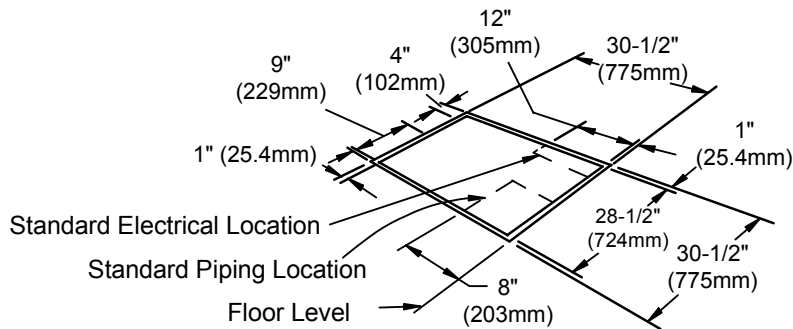
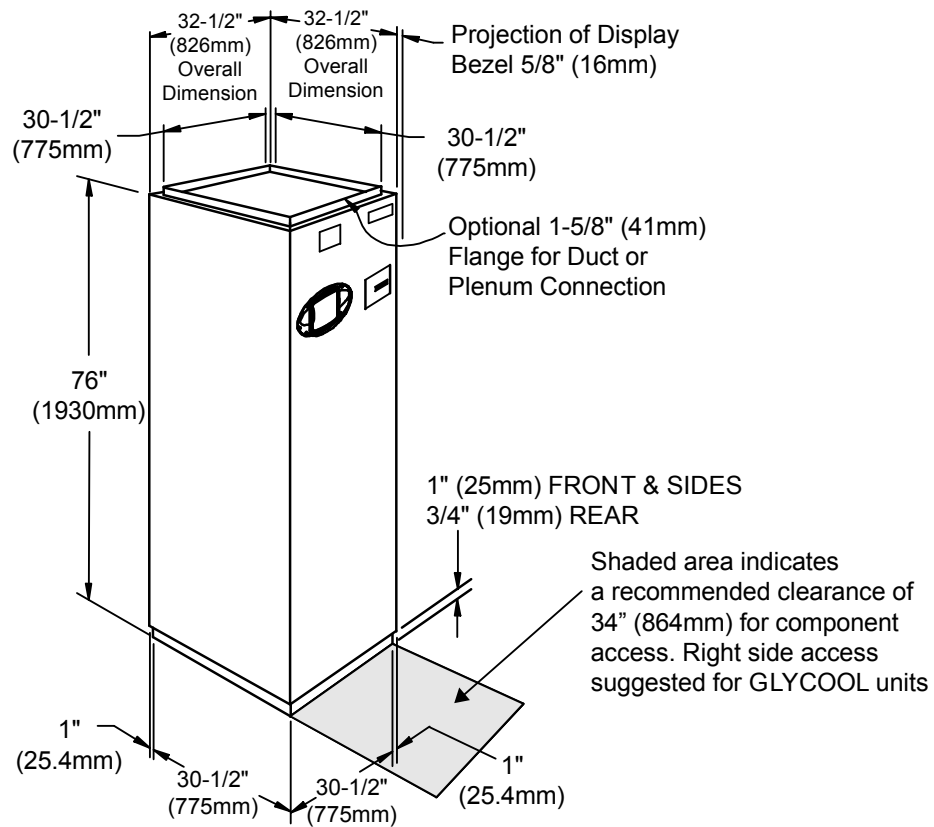
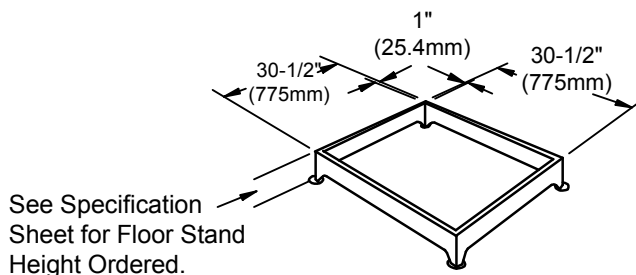

Figure 14 Cabinet and floor planning dimensions—Downflow (BF/BE) models



FLOOR CUTOUT DIMENSIONS



OPTIONAL FLOOR STAND DIMENSIONAL DATA

Unit Weight		
50Hz Models	60Hz Models	lb (kg)
BF035E	BF036E	535 (243)
BF059E	BF060E	545 (247)
BF040A	BF042A	615 (279)
BF065A	BF067A	670 (304)
BF045WG	BF046WG	700 (318)
BF070WG	BF071WG	750 (340)
BF072C	BF068C	545 (247)
BF101C	BF102C	555 (252)
BE058G	BE061G	785 (356)

DPN000351
Rev. 01

Figure 15 Cabinet dimensions - Split system, 3 ton indoor air-cooled condensing unit

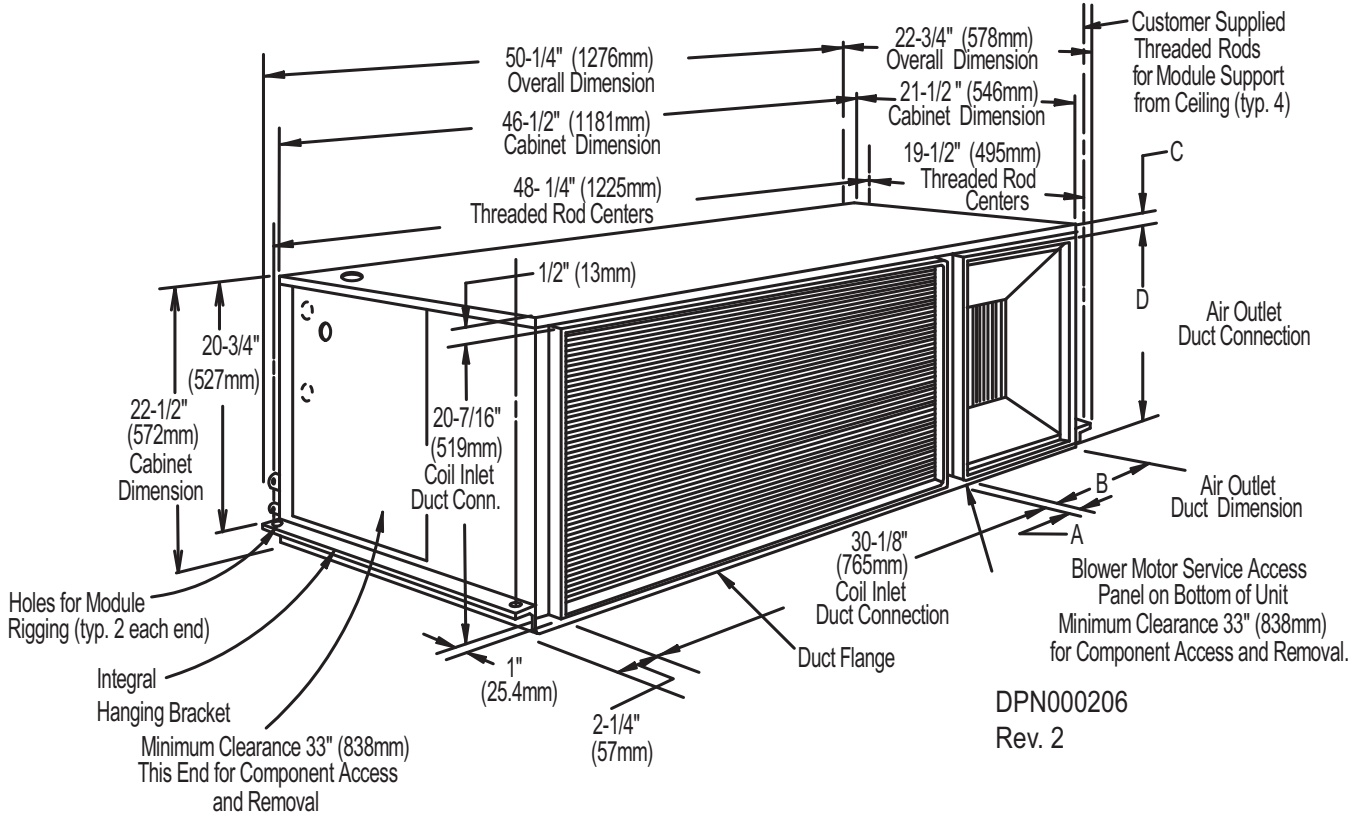

Model	Dimensions, in (mm)			
	A	B	C	D
MC_39A	1-5/8	11-3/4	3/4	20-1/4
MC_40A	(41)	(298)	(19)	(514)

Model		Net Weight lb (kg)
60Hz	50Hz	
MC_40A	MC_39A	240 (109)

Figure 16 Cabinet dimensions - Split system, 5 ton indoor air-cooled condensing unit

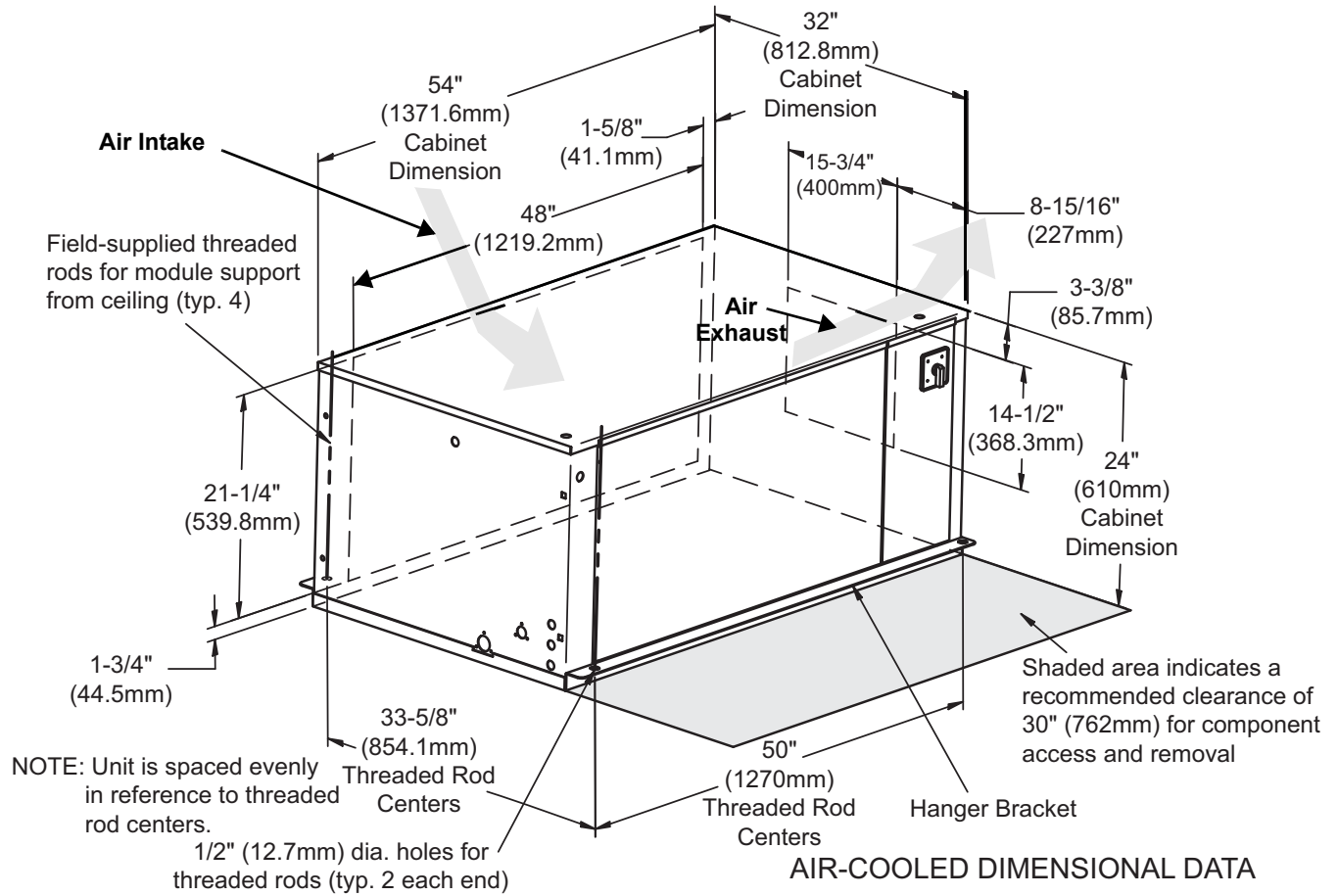

Model		Net Weight lb (kg)
60Hz	50Hz	
MC_65A	MC_64A	449 (204)

Figure 17 Cabinet dimensions - Split system, indoor 3 ton water/glycol-cooled condensing unit

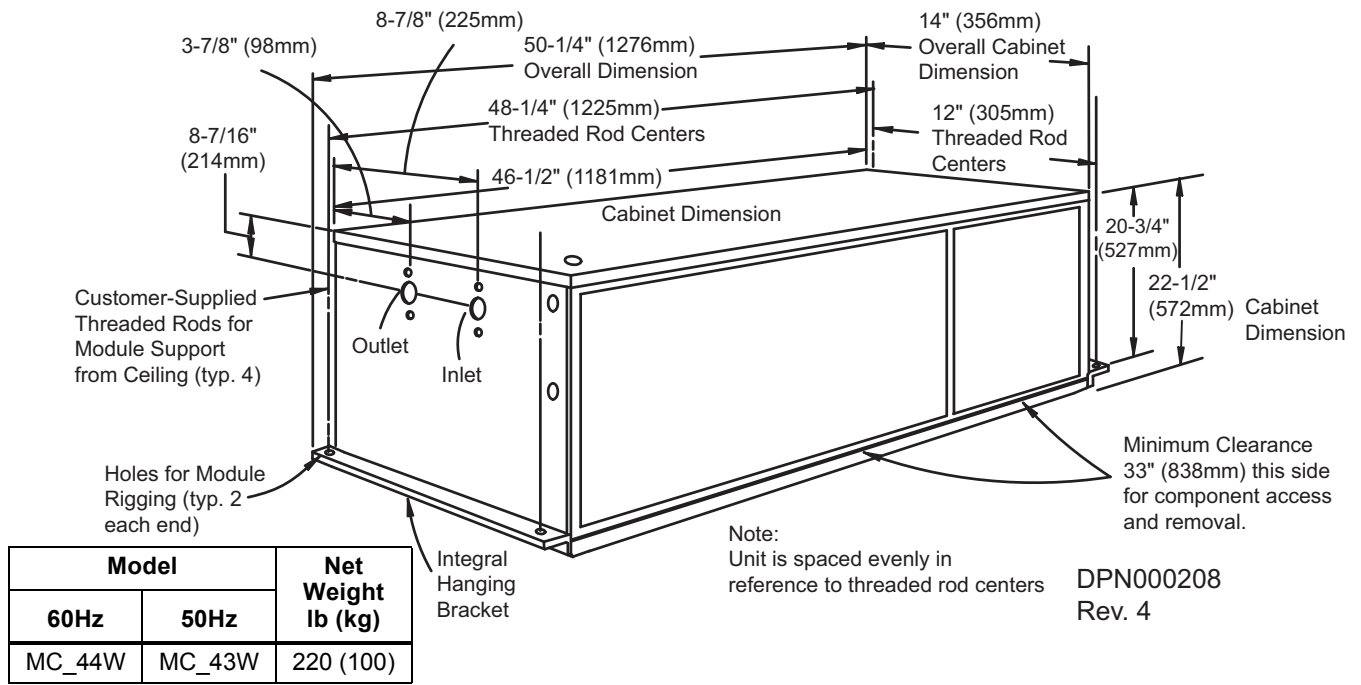

Figure 18 Cabinet dimensions—Split system, 5-ton water/glycol-cooled condensing unit

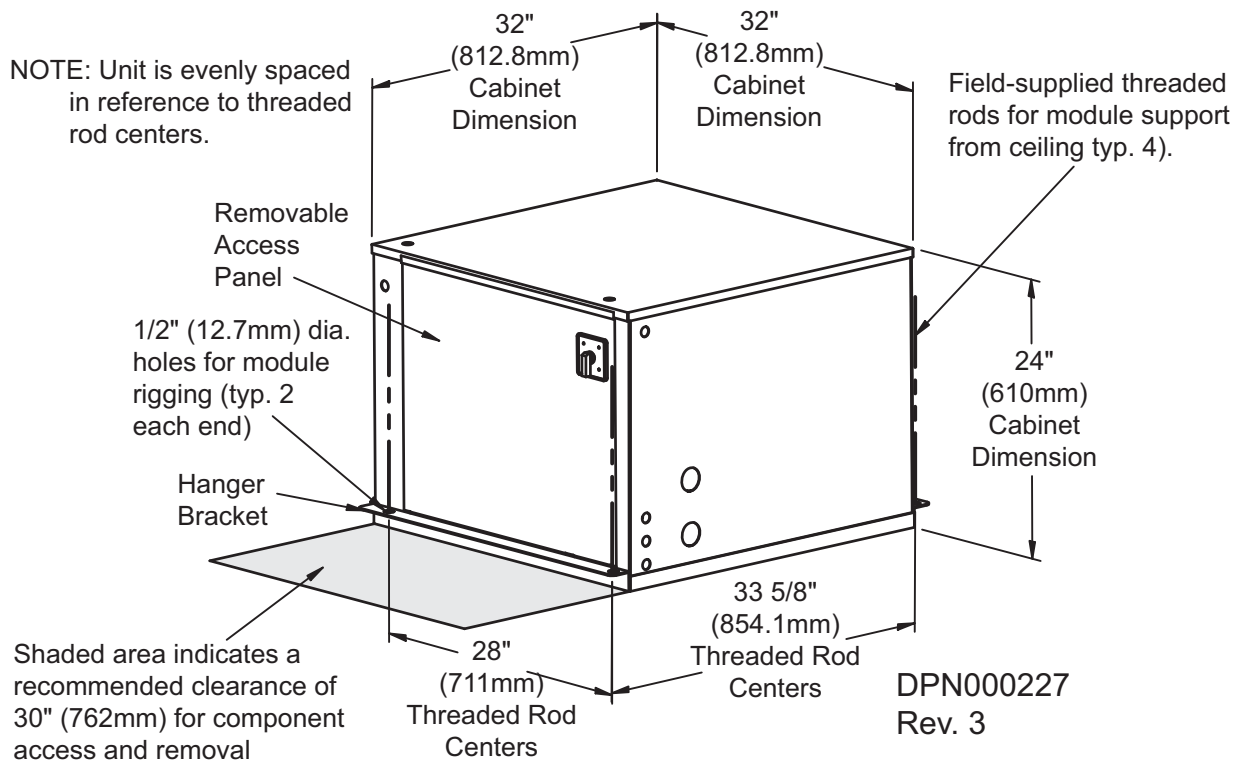
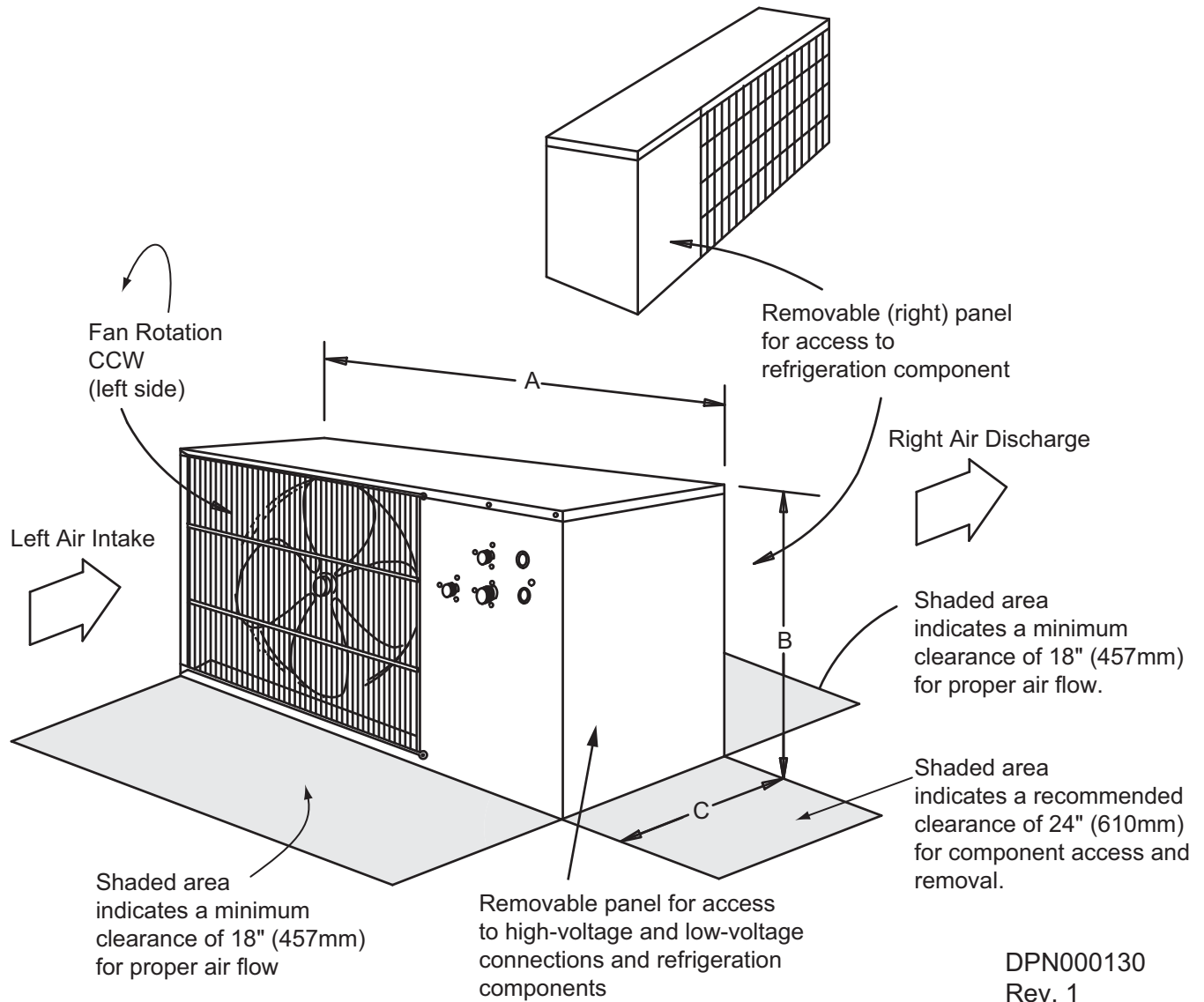

Figure 19 Cabinet and floor planning dimensions—Split System, propeller fan condensing unit



DPN000130
Rev. 1

Outdoor Propeller Fan Condensing Unit					
Model		Width (A)	Depth (C)	Height (B)	Net Weight lb (kg)
60Hz	50Hz	Dimensions - Inches (mm)			
PFH042A-_L	PFH041A-_L	48 (1219)	18 (457)	31 (787)	241 (109)
PFH042A-_H	PFH041A-_H	53 (1343)	18 (457)	36-1/4 (918)	351 (159)
PFFZ42A-_L	PFHZ41A-_L	53 (1343)	18 (457)	36-1/4 (918)	351 (159)
PFH067A-_L	PFH066A-_L	53 (1343)	18 (457)	36-1/4 (918)	351 (159)

Source: DPN000130, Rev. 1

Figure 20 Cabinet and floor planning dimensions—Split system 5 ton outdoor condensing unit, high ambient and Liebert Quiet-Line™ models

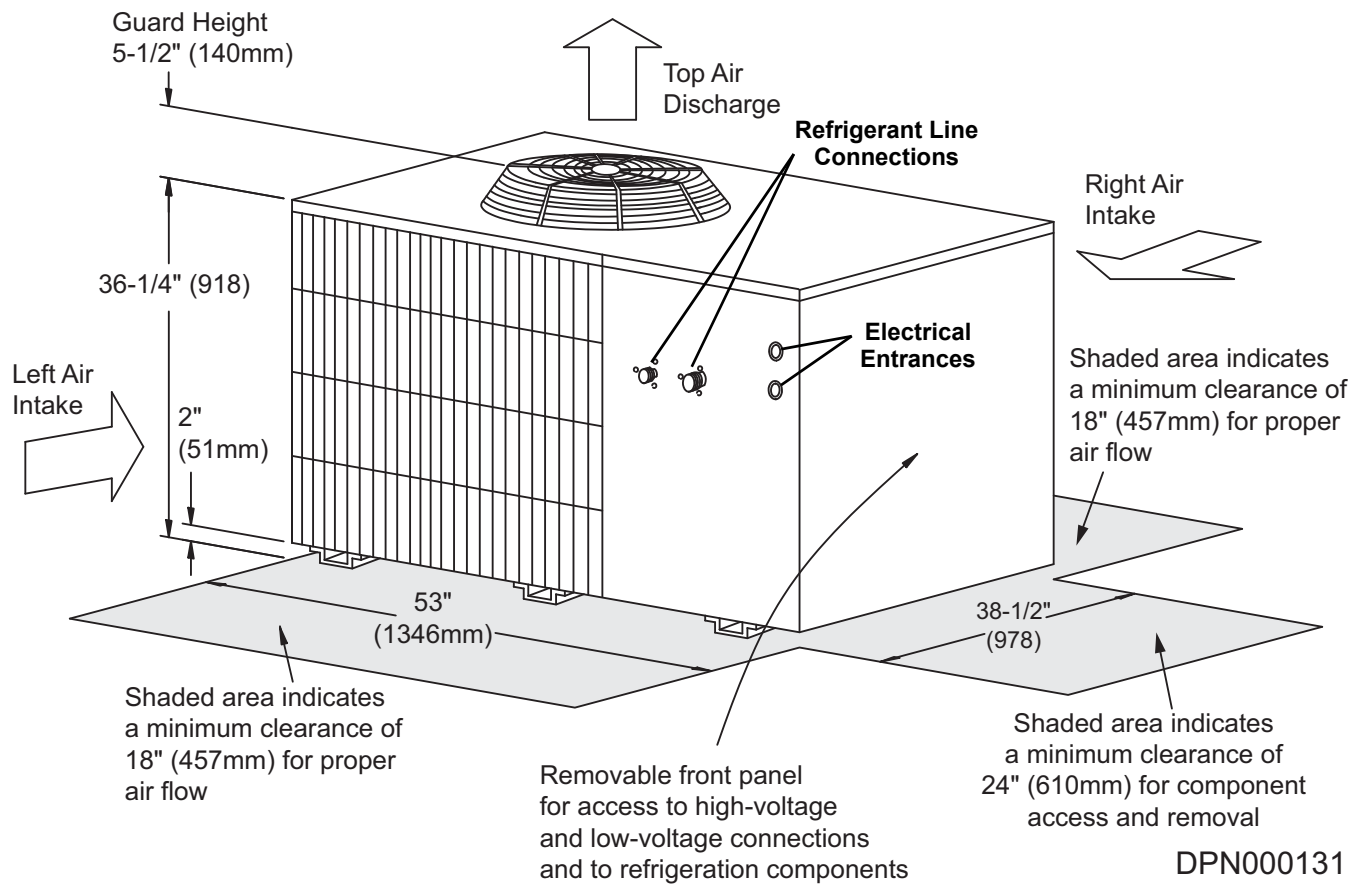

DPN000131
Rev. 0

Model Numbers		Dimensions in. (mm)				Module Weight
60Hz	50Hz	A	B	C	D	lb (kg) net.
PFH067A-_H	PFH066A-_H	53 (1343)	36-1/4 (918)	38-1/2 (978)	5-1/2 (140)	488 (222)
PFHZ67A-_L	PFHZ66A-_L					

Figure 21 Liebert MC™ condenser planning dimensions—MCS028

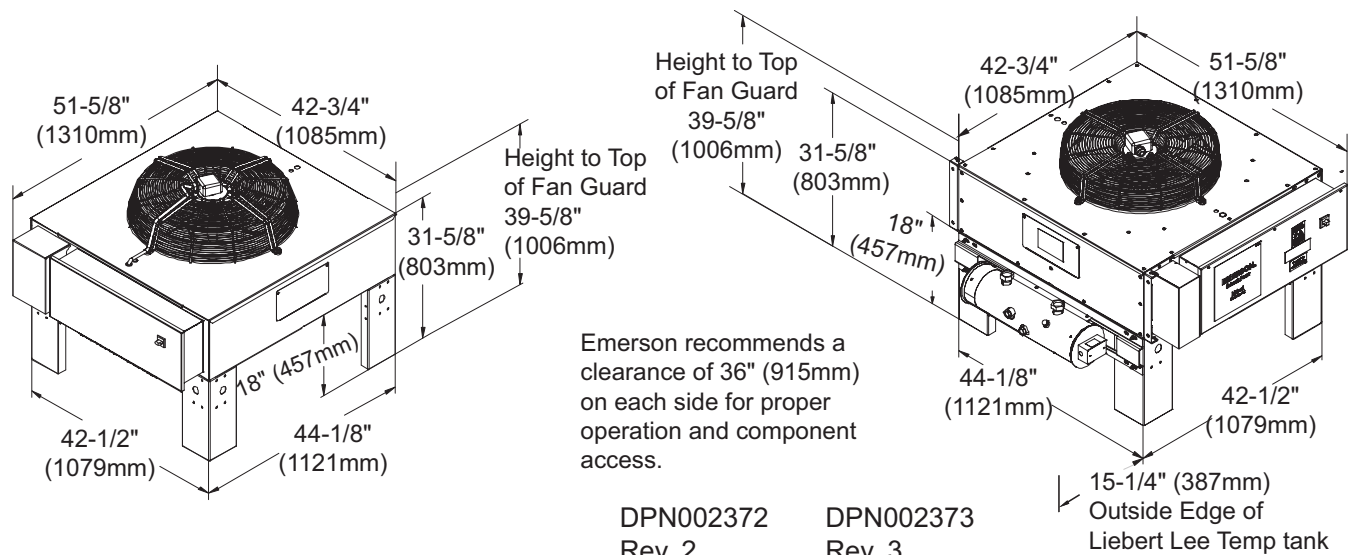

DPN002372
Rev. 2

DPN002373
Rev. 3

Figure 22 Cabinet and floor planning dimensions—Self-contained system, air-cooled fin/tube condenser or drycooler

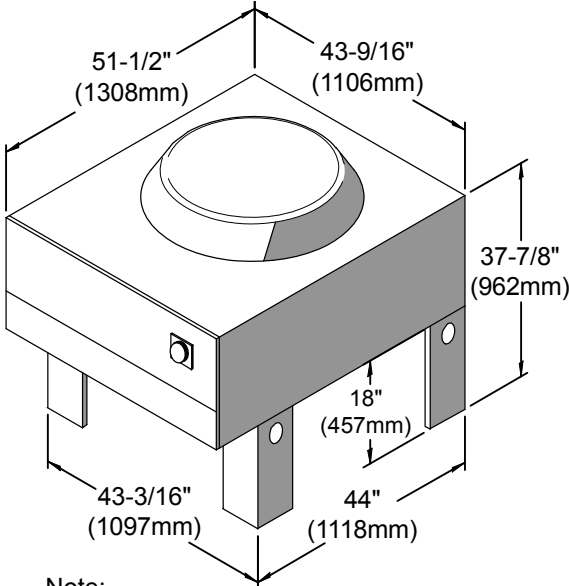

Note:
Overall height to the top of fan guard
43-1/8" (1095mm)

Figure 23 Fin/tube condenser and drycooler dimensions, two-fan model

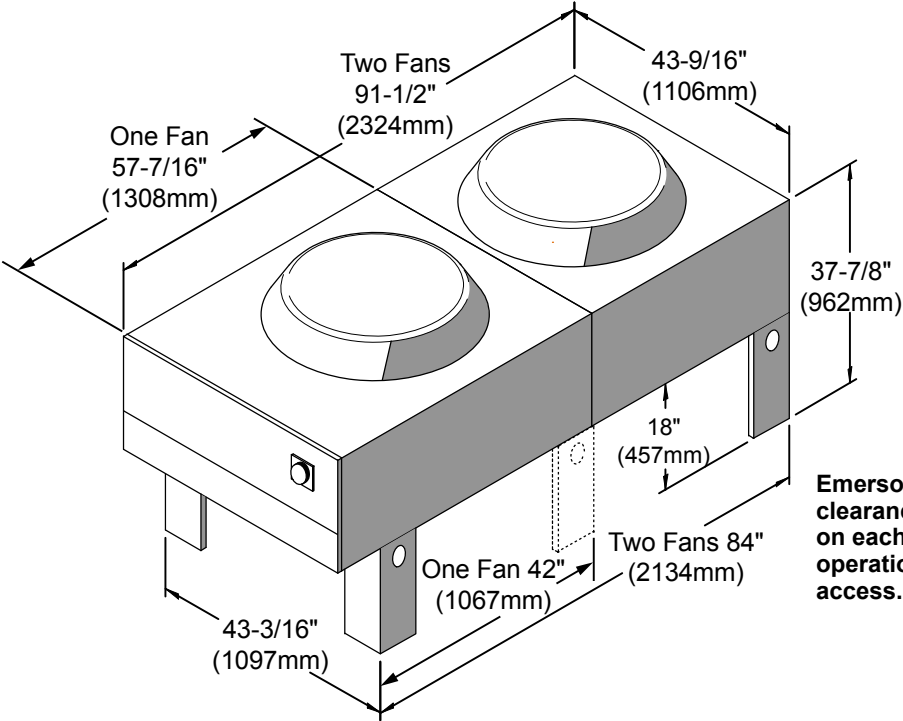

Emerson recommends a clearance of 36" (915mm) on each side for proper operation and component access.

Figure 24 Cabinet and floor planning dimensions—Piggyback condenser

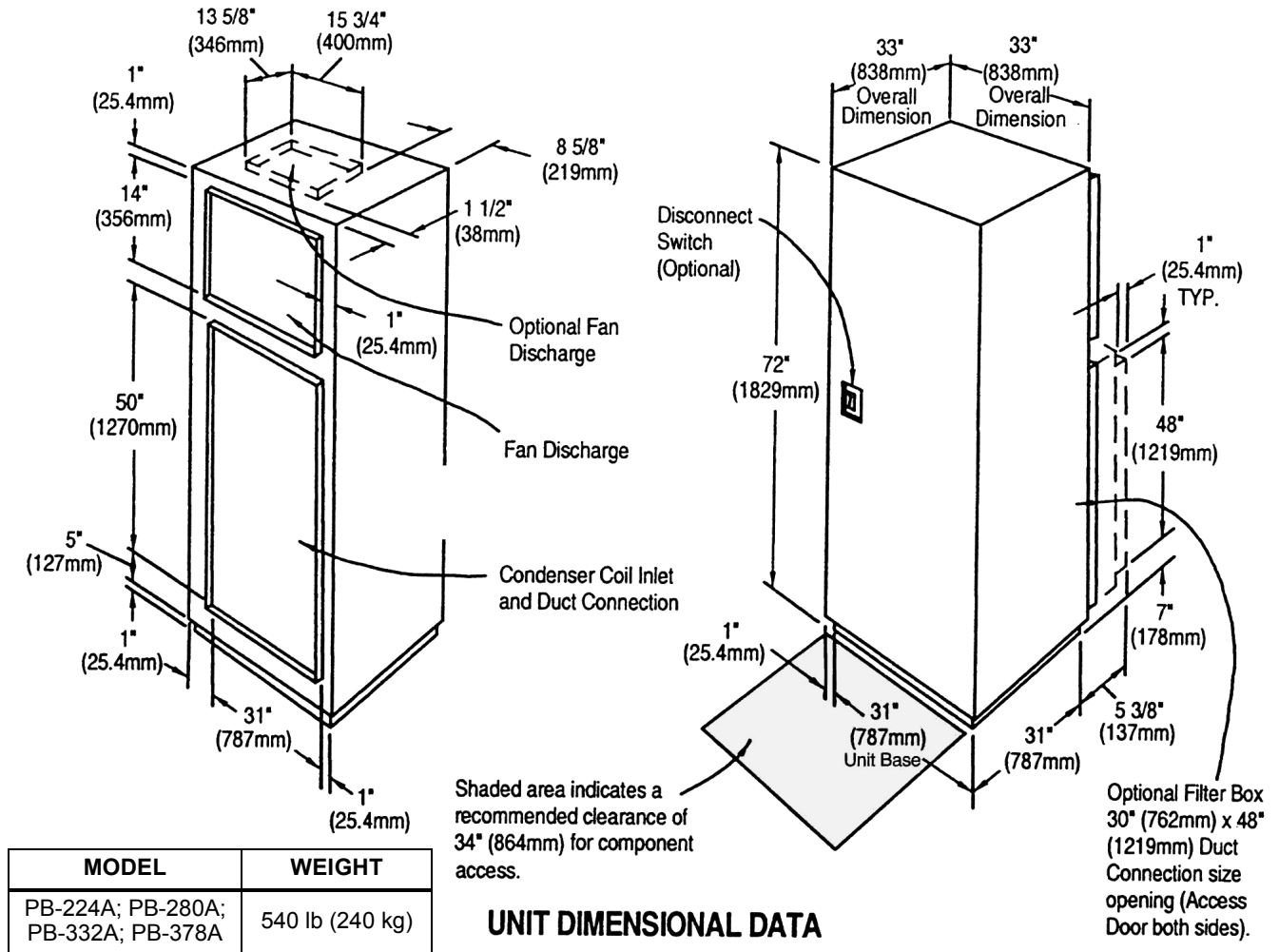

19.0 ELECTRICAL DATA—60Hz

Table 10 Liebert Challenger 3000 electrical data—60Hz

Model Type	Self-Contained								Split System Evaporator or Chilled Water							
	3 Ton B*042A, 046WG				5 Ton B*067A, 071WG, 061G				3 Ton B*036E, 068C				5 Ton B*060E, 102C			
Voltage	All Voltages Are 3 Phase Unless Otherwise Noted															
	208	230	460	575	208	230	460	575	208	230	460	575	208	230	460	575
With Electric Reheat & Humidifier (Infrared or Steam Generating) (Note: See Table 11 for units w/SCR reheats. 1)																
Motor	0.75hp (0.56kW)				1.5hp (1.1 kW) 2				0.75hp (0.56kW)				1.5hp (1.1kW) 2			
FLA	42.1	40.4	19.8	17.7	68.9	65.8	32.7	24.9	41.8	37.9	19.2	17.7	61.5	56.2	28.5	24.9
WSA	52.3	49.7	24.4	22.1	84.5	80.8	40.1	31.1	52.3	47.4	24.0	22.1	76.9	70.3	35.6	31.1
OPD	50	50	25	25	90	90	45	30	60	50	25	25	80	80	40	35
Motor	1.0 hp (0.75 kW)				2.0 hp (1.5 kW)				1.0 hp (0.75 kW)				2.0 hp (1.5 kW)			
FLA	43.2	41.4	20.3	18.1	69.8	66.6	33.1	25.2	42.9	38.9	19.7	18.1	62.4	57.0	28.9	25.2
WSA	53.6	50.7	24.9	22.6	85.4	81.6	40.5	31.5	53.6	48.6	24.6	22.6	78.0	71.3	36.1	31.5
OPD	60	50	25	25	90	90	45	30	60	50	25	25	80	80	40	35
Motor	1.5 hp (1.1 kW)				3.0 hp (2.2 kW)				1.5 hp (1.1 kW)				3.0 hp (2.2 kW)			
FLA	45.2	43.2	21.2	18.8	72.9	69.4	34.5	26.4	44.9	40.7	20.6	18.8	65.5	59.8	30.3	26.4
WSA	56.1	52.5	25.8	23.5	88.5	84.4	41.9	33.0	56.1	50.9	25.8	23.5	81.9	74.8	37.9	33.0
OPD	60	60	25	25	90	90	45	35	60	60	30	25	90	80	40	35
Humidifier Only (Infrared or Steam Generating)																
Motor	0.75hp (0.56kW)				1.5hp (1.1 kW) 2				0.75hp (0.56kW)				1.5hp (1.1kW) 2			
FLA	30.4	27.9	13.8	13.5	40.6	37.8	18.8	17.2	16.8	14.3	7.4	8.7	19.9	17.1	8.8	9.8
WSA	33.8	31.3	15.4	14.7	45.8	43.0	21.3	19.1	21.0	17.9	9.3	10.9	24.9	21.4	11.0	12.3
OPD	45	40	20	15	60	60	30	25	20	15	15	15	25	20	15	15
Motor	1.0 hp (0.75kW)				2.0 hp (1.5kW)				1.0hp (0.75kW)				2.0hp (1.5kW)			
FLA	31.5	28.9	14.3	13.9	41.5	38.6	19.2	17.5	17.9	15.3	7.9	9.1	20.8	17.9	9.2	10.1
WSA	34.9	32.3	15.9	15.1	46.7	43.8	21.7	19.4	22.4	19.1	9.9	11.4	26.0	22.4	11.5	12.6
OPD	45	45	20	15	60	60	30	25	20	20	15	15	30	25	15	15
Motor	1.5 hp (1.1 kW)				3.0 hp (2.2 kW)				1.5 hp (1.1 kW)				3.0 hp (2.2 kW)			
FLA	33.5	30.7	15.2	14.6	44.6	41.4	20.6	18.7	19.9	17.1	8.8	9.8	23.9	20.7	10.6	11.3
WSA	36.9	34.1	16.8	15.8	49.8	46.6	23.1	20.6	24.9	21.4	11.0	12.3	29.9	25.9	13.3	14.1
OPD	50	45	20	15	70	60	30	25	25	20	15	15	35	30	15	15
Electric Reheat Only (Note: See Table 11 for Self-contained units w/SCR reheats. 1)																
Motor	0.75hp (0.56kW)				1.5hp (1.1 kW) 2				0.75hp (0.56kW)				1.5hp (1.1kW) 2			
FLA	42.1	40.4	19.8	15.1	68.9	65.8	32.7	24.9	28.5	26.8	13.4	10.3	48.2	45.1	22.7	17.5
WSA	51.8	49.7	24.4	18.6	84.5	80.8	40.1	30.5	35.6	33.5	16.8	12.9	60.3	56.4	28.4	21.9
OPD	50	50	25	20	90	90	45	30	40	35	20	15	70	60	30	25
Motor	1.0hp (0.75kW)				2.0hp (1.5kW)				1.0hp (0.75kW)				2.0hp (1.5kW)			
FLA	43.2	41.4	20.3	15.5	69.8	66.6	33.1	25.2	29.6	27.8	13.9	10.7	49.1	45.9	23.1	17.8
WSA	52.9	50.7	24.9	19.0	85.4	81.6	40.5	30.8	37.0	34.8	17.4	13.4	61.4	57.4	28.9	22.3
OPD	60	50	25	20	90	90	45	30	40	35	20	15	70	60	30	25
Motor	1.5 hp (1.1 kW)				3.0 hp (2.2 kW)				1.5 hp (1.1 kW)				3.0 hp (2.2 kW)			
FLA	45.2	43.2	21.2	16.2	72.9	69.4	34.5	26.4	31.6	29.6	14.8	11.4	52.2	48.7	24.5	19.0
WSA	54.9	52.5	25.8	19.7	88.5	84.4	41.9	32.0	39.5	37.0	18.5	14.3	65.3	60.9	30.6	23.8
OPD	60	60	25	20	90	90	45	35	35	35	15	15	60	70	35	20
Without Electric Reheat & Humidifier																
Motor	0.75hp (0.56kW)				1.5hp (1.1 kW) 2				0.75hp (0.56kW)				1.5hp (1.1kW) 2			
FLA	17.1	16.8	8.0	6.1	27.3	26.7	13.0	9.8	3.5	3.2	1.6	1.3	6.6	6.0	3.0	2.4
WSA	20.5	20.2	9.6	7.3	32.5	31.9	15.5	11.7	4.4	4.0	2.0	1.6	8.3	7.5	3.8	3.0
OPD	30	30	15	15	50	50	25	15	15	15	15	15	15	15	15	15
Motor	1.0hp (0.75kW)				2.0hp (1.5kW)				1.0hp (0.75kW)				2.0hp (1.5kW)			
FLA	18.2	17.8	8.5	6.5	28.2	27.5	13.4	10.1	4.6	4.2	2.1	1.7	7.5	6.8	3.4	2.7
WSA	21.6	21.2	10.1	7.7	33.4	32.7	15.9	12.0	5.8	5.3	2.6	2.1	9.4	8.5	4.3	3.4
OPD	35	30	15	15	50	50	25	15	15	15	15	15	15	15	15	15
Motor	1.5hp (1.1kW)				3.0hp (2.2kW)				1.5hp (1.1kW)				3.0hp (2.2kW)			
FLA	20.2	19.6	9.4	7.2	31.3	30.3	14.8	11.3	6.6	6.0	3.0	2.4	10.6	9.6	4.8	3.9
WSA	23.6	23.0	11.0	8.4	36.5	35.5	17.3	13.2	8.3	7.5	3.8	3.0	13.3	12.0	6.0	4.9
OPD	35	35	15	15	50	50	25	20	15	15	15	15	20	20	15	15

1. For Split System Evaporators with SCR reheat, use the values above.
 2. 1.5hp (1.1kW) motor in 5 ton model cannot supply standard airflow.
 The values above were calculated per UL Standard 1995.
 FLA = Full Load Amps (Input Amps); WSA= Wire Size Amps (Minimum Supply Circuit Ampacity); OPD= Maximum Overcurrent Protective Device Size RLA= Rated Load Amps; LRA= Locked Rotor Amps
 * F= Downflow; U= Upflow; E= Downflow with Econ-O-Coil; K= Upflow with Econ-O-Coil

Table 11 Self-contained with SCR reheat ²

Model	3 Ton				5 Ton			
Voltage (3, 60Hz)	208	230	460	575	208	230	460	575
Electric (SCR) Reheat & Humidifier (Infrared or Steam Generating)								
Motor	0.75 hp (0.56 kW)				1.5hp (1.1kW) ¹			
FLA	55.4	51.5	25.6	N/A	82.2	76.9	38.5	NA
WSA	65.1	60.8	30.2	N/A	97.8	91.9	45.9	NA
OPD	70	60	30	N/A	100	100	50	NA
Motor	1.0 hp (0.75 kW)				2.0 hp (1.5 kW)			
FLA	56.5	52.5	26.1	N/A	83.1	77.7	38.9	NA
WSA	66.2	61.8	30.7	N/A	98.7	92.7	46.3	NA
OPD	70	70	30	N/A	100	100	50	NA
Motor	1.5 hp (1.1 kW)				3.0 hp (2.2 kW)			
FLA	58.5	54.3	27.0	N/A	86.2	80.5	40.3	NA
WSA	68.2	63.6	31.6	N/A	101.8	95.5	47.7	NA
OPD	70	70	35	N/A	110	100	50	NA
Electric (SCR) Reheat Only								
Motor	0.75 hp (0.56 kW)				1.5hp (1.1kW) ¹			
FLA	42.1	40.4	19.8	N/A	68.9	65.8	32.7	NA
WSA	51.8	49.7	24.4	N/A	84.5	80.8	40.1	NA
OPD	50	50	25	N/A	90	90	45	NA
Motor	1.0 hp (0.75 kW)				2.0 hp (1.5 kW)			
FLA	43.2	41.4	20.3	N/A	69.8	66.6	33.1	NA
WSA	52.9	50.7	24.9	N/A	85.4	81.6	40.5	NA
OPD	60	50	25	N/A	90	90	45	NA
Motor	1.5 hp (1.1 kW)				3.0 hp (2.2 kW)			
FLA	45.2	43.2	21.2	N/A	72.9	69.4	34.5	NA
WSA	54.9	52.5	25.8	N/A	88.5	84.4	41.9	NA
OPD	60	60	25	N/A	90	90	45	NA

1. 1.5 HP motor in 5 ton model cannot supply standard airflow.
2. Compressor is locked On. Heater is same size as standard.

Table 12 Scroll compressor and main fan (for comparison purposes only)

Model	3 Ton				5 Ton			
Voltage (3, 60Hz)	208	230	460	575	208	230	460	575
Scroll Compressor								
RLA	13.6	13.6	6.4	4.8	20.7	20.7	10.0	7.4
LRA	93.0	93.0	48.0	33.0	137.0	137.0	63.0	53.0
Main Fan								
Motor	.75 hp (.56 kW)				1.5 hp (1.1 kW)			
RLA	3.5	3.2	1.6	1.3	6.6	6.0	3.0	2.4
LRA	27.6	25.0	12.5	10.0	44.0	40.0	20.0	16.0
Motor	1.0 hp (.75 kW)				2.0 hp (1.5 kW)			
RLA	4.6	4.2	2.1	1.7	7.5	6.8	3.4	2.7
LRA	33.0	30.0	15.0	12.0	55.0	50.0	25.0	20.0
Motor	1.5 hp (1.1 kW)				3.0 hp (2.2 kW)			
RLA	6.6	6.0	3.0	2.4	10.6	9.6	4.8	3.9
LRA	44.0	40.0	20.0	16.0	71.0	64.0	32.0	25.6

Table 13 Outdoor condensing units

Electrical Data, 60Hz, 95°F (35°C) Ambient			
Voltage	Model	PFH042A-_L	PFH067A-_L
208/230-3-60	FLA	15.0	24.1
	WSA	18.4	29.3
	OPD	30	45
460-3-60	FLA	7.1	11.7
	WSA	8.7	14.2
	OPD	15	20
575-3-60	FLA	6.0	9.1
	WSA	7.2	11.1
	OPD	15	15
Electrical Data, 60Hz, 105°F (40°C) Ambient			
Voltage	Model	PFH042A-_H	PFH067A-_H
208/230-3-60	FLA	17.0	24.2
	WSA	20.4	29.4
	OPD	30	50
460-3-60	FLA	8.1	11.7
	WSA	9.7	14.2
	OPD	15	20
575-3-60	FLA	6.0	9.3
	WSA	7.2	11.3
	OPD	15	15
Electrical Data, 60Hz, Quiet-Line, 95°F (35°C)			
Voltage	Model	PFHZ42A-_L	PFHZ67A-_L
208/230-3-60	FLA	14.5	21.1
	WSA	17.9	25.9
	OPD	30	45
460-3-60	FLA	6.9	10.9
	WSA	8.5	13.4
	OPD	15	20

Table 14 Indoor condensing units, air-cooled

Electrical Data 60Hz 95°F (35°C) Ambient			
Voltage	Model	MC_40A	MC_65A
208/230-3-60	FLA	20.2	26.5
	WSA	23.6	31.7
	OPD	35	50
460-3-60	FLA	9.7	12.9
	WSA	11.3	15.4
	OPD	15	25
575-3-60	FLA	N/A	9.7
	WSA	N/A	11.6
	OPD	N/A	15

Table 15 Indoor condensing units, water-cooled

Voltage	Model	MC_44W	MC_69W
208/230-3-60	FLA	13.6	20.7
	WSA	17.0	25.9
	OPD	30	45
460-3-60	FLA	6.4	10.0
	WSA	8.0	12.5
	OPD	15	20
575-3-60	FLA	n/a	7.4
	WSA	n/a	9.3
	OPD	n/a	15

Table 16 Liebert MC™ condensers

Condenser	95°F (35°C) Ambient (3 Phase - 60Hz)			
	MCS028		MCM040	
Voltage	208/230V	460V	208/230V	460V
FLA	3.0	1.4	2.3	1.4
WSA	3.8	1.8	3.2	1.9
OPD	15	15	15	15

Table 17 Fan speed control fin/tube condensers

95°F (35°C) Ambient (1 Phase - 60Hz)			
DCSF083/DCSF104			
Voltage	208/230	460	575
FLA	4.8	2.5	1.9
WSA	6.0	3.1	2.4
OPD	15	15	15

Table 18 Liebert fin/tube condensers with Liebert Lee-Temp™

95°F (35°C) Ambient (3 Phase - 60Hz)			
DCSL083/DCSL104			
Voltage	208/230	460	575
FLA	3.5	1.7	1.4
WSA	4.4	2.1	1.8
OPD	15	15	15

Table 19 VFD-controlled fin/tube condensers

95°F (35°C) Ambient (3 Phase - 60Hz)		
TCSV083/TCSV104		
Voltage	208/230	460
FLA	3.7	1.8
WSA	4.6	2.3
OPD	15	15

Table 20 Liebert Lee-Temp receiver heater pads for use w/Liebert MC™ and fin/tube condensers

Volts	120	230
Watts/Pad	150	150
FLA	1.4	0.7
WSA	1.8	0.9
OPD	15	15

Separate electrical source required for continuous operation of single phase heater pads for Liebert Lee-Temp.

Table 21 Drycooler and pump package—95°F (35°C) ambient, 3-phase

Tonnage	3 Ton			5 Ton		
	208/230	460	575	208/230	460	575
Glycol	Drycooler and Pump					
DSF Model	092	092	092	109	109	109
Pump hp	0.75	0.75	0.75	0.75	0.75	0.75
FLA	7.0	3.3	2.7	7.0	3.3	2.7
WSA	7.9	3.7	3.1	7.9	3.7	3.1
OPD	15	15	15	15	15	15
GLYCOOL	Drycooler and Pump					
DSO Model	-	-	-	109	109	109
Pump hp	-	-	-	1.5	1.5	1.5
FLA	-	-	-	10.1	4.7	3.8
WSA	-	-	-	11.8	5.5	4.4
OPD	-	-	-	15	15	15

1. Pump and drycooler powered from same 3-phase feeder.

Table 22 Drycooler only—95°F (35°C) ambient, single-phase

Tonnage	3 Ton			5 Ton		
	208/230	460	575	208/230	460	575
Glycol	Drycooler					
DSF Model	092	092	092	109	109	109
FLA	4.8	2.4	1.9	4.8	2.4	1.9
GLYCOOL	Drycooler					
DSO Model	-	-	-	109	109	109
FLA	-	-	-	4.0	2.0	1.4

Table 23 Pumps, three-phase

hp	Voltage (3 Phase - 60Hz)				
		208	230	460	575
3/4	FLA	3.5	3.5	1.6	1.3
1-1/2	FLA	6.6	6.6	3	2.4
2	FLA	7.5	7.5	3.4	2.7

20.0 ELECTRICAL DATA—50Hz

Table 24 Liebert Challenger 3000 electrical data—50Hz

Model Type	Self-Contained						Split System Evaporator or Chilled Water					
	3 Ton B*040A, 045WG			5 Ton B*065A, 070WG, 058G			3 Ton B*035E, 072C			5 Ton B*059E, 101C		
	3 Phase, 50Hz											
Voltage	200	230	380/415	200	230	380/415	200	230	380/415	200	230	380/415
With Electric Reheat & Humidifier (Infrared or Steam Generating) (Note: See Table 25 for units w/SCR reheats.¹)												
Motor	0.75 kW (1.0 hp)			1.5 kW (2.0 hp)			0.75 kW (1.0 hp)			1.5 kW (2.0 hp)		
FLA	43.5	42.6	22.8	67.9	66.1	35.3	40.6	38.0	21.3	60.0	56.5	31.7
Motor	1.1 kW (1.5 hp)			2.2 kW (3.0 hp)			1.1 kW (1.5 hp)			2.2 kW (3.0 hp)		
FLA	46.3	45.0	24.2	70.5	68.3	36.6	43.4	40.4	22.7	62.6	58.7	33.0
Humidifier Only (Infrared or Steam Generating)												
Motor	0.75 kW (1.0 hp)			1.5 kW (2.0 hp)			0.75 kW (1.0 hp)			1.5 kW (2.0 hp)		
FLA	32.3	30.1	16.2	40.7	38.1	20.0	16.6	14.4	8.3	20.0	17.4	10.0
Motor	1.1 kW (1.5 hp)			2.2 kW (3.0 hp)			1.1 kW (1.5 hp)			2.2 kW (3.0 hp)		
FLA	35.1	32.5	17.6	43.3	40.3	21.3	19.4	16.8	9.7	22.6	19.6	11.3
Electric Reheat Only (Note: See Table 25 for units w/SCR reheats.¹)												
Motor	0.75 kW (1.0 hp)			1.5 kW (2.0 hp)			0.75 kW (1.0 hp)			1.5 kW (2.0 hp)		
FLA	43.5	42.6	22.8	67.9	66.1	35.3	27.8	26.9	14.9	47.2	45.4	25.3
Motor	1.1 kW (1.5 hp)			2.2 kW (3.0 hp)			1.1 kW (1.5 hp)			2.2 kW (3.0 hp)		
FLA	46.3	45.0	24.2	70.5	68.3	36.6	30.6	29.3	16.3	49.8	47.6	26.6
Without Electric Reheat & Humidifier												
Motor	0.75 kW (1.0 hp)			1.5 kW (2.0 hp)			0.75 kW (1.0 hp)			1.5 kW (2.0 hp)		
FLA	19.5	19.0	9.8	27.9	27.0	13.6	3.8	3.3	1.9	7.2	6.3	3.6
Motor	1.1 kW (1.5 hp)			2.2 kW (3.0 hp)			1.1 kW (1.5 hp)			2.2 kW (3.0 hp)		
FLA	22.3	21.4	11.2	30.5	29.2	14.9	6.6	5.7	3.3	9.8	8.5	4.9

1. For Split System Evaporators with SCR reheat, use the values above.

FLA = Full Load Amps (Input Amps)

RLA = Rated Load Amps

LRA = Locked Rotor Amps

* F = Downflow

U = Upflow

E = Downflow with Econ-O-Coil

K = Upflow with Econ-O-Coil

Table 25 Self-contained with SCR reheat

Model	3 Ton			5 Ton		
Voltage (3, 50Hz)	200	230	380/415	200	230	380/415
Electric Reheat & Humidifier (Infrared or Steam Generating)						
Motor	.75 kW (1.0 hp)			1.5 kW (2.0 hp)		
FLA	56.3	53.7	29.2	80.7	77.2	41.7
Motor	1.1 kW (1.5 hp)			2.2 kW (3.0 hp)		
FLA	59.1	56.1	30.6	83.3	79.4	43.0
Electric Reheat Only						
Motor	.75 kW (1.0 hp)			1.5 kW (2.0 hp)		
FLA	43.5	42.6	22.8	67.7	65.9	35.2
Motor	1.1 kW (1.5 hp)			2.2 kW (3.0 hp)		
FLA	46.3	45.0	24.2	70.8	68.6	36.8

Compressor is locked On. Heater is same size as standard.

Table 26 Scroll compressor and main fan (for comparison purposes only)

Model	3 Ton			5 Ton		
Voltage (3, 50Hz)	200	230	380/415	200	230	380/415
Scroll Compressor						
RLA	15.7	15.7	7.9	20.7	20.7	10.0
LRA	114.0	114.0	60.0	156.0	172.0	74.0
Main Fan						
Motor	.75 kW (1.0 hp)			1.5 kW (2.0 hp)		
RLA	3.8	3.3	1.9	7.2	6.3	3.6
LRA	22.7	19.7	11.8	56.4	49.0	28.2
Motor	1.1 kW (1.5 hp)			2.2 kW (3.0 hp)		
RLA	6.6	5.7	3.3	9.8	8.5	4.9
LRA	48.0	41.7	24.0	58.4	50.8	29.2

Table 27 Outdoor condensing units

Electrical Data 50Hz 35°C (95°F) Ambient			
Voltage	Model	PFH041A-_L	PFH066A-_L
380/415-3-50	FLA	7.0	13.2
Electrical Data 50Hz 40°C (105°F) Ambient			
Voltage	Model	PFH041A-_H	PFH066A-_H
380/415-3-50	FLA	8.1	13.2
Electrical Data 50Hz Quiet-Line 35°C (95°F)			
Voltage	Model	PFHZ41A-_L	PFHZ66A-_L
380/415-3-50	FLA	8.4	12.4

Table 28 Indoor condensing units air-cooled

Electrical Data 50Hz 35°C (95°F) Ambient			
Voltage	Model	MC_39A	MC_64A
380/415-3-50	FLA	10.8	13.7

1. Consult factory for 200/230 volts.

Table 29 Indoor condensing units water-cooled

Voltage	Model	MC_43W	MC_68W
380/415-3-50	FLA	7.9	10.0

1. Consult factory for 200/230 volts.

Table 30 Fan speed control condensers

35°C (95°F) Ambient (1 Phase - 50Hz)			
DCSF083/DCSF104			
Voltage	200	220	380/415
FLA	4.0	4.0	—

Table 31 VFD controlled condenser

35°C (95°F) Ambient (3 Phase - 50Hz)		
TCSV083/TCSV104		
Voltage	208/220	380/ 415
FLA	3.7	1.8

Table 32 Liebert Lee-Temp™ condensers

35°C (95°F) Ambient (3 Phase - 50Hz)			
DCSL083/DCSF104			
Voltage	200	220	380/ 415
FLA	3.5	3.5	1.7

Table 33 Liebert Lee-Temp receiver heater pads; for use w/DCSL condensers

Volts	230
Watts/Pad	150
Amps	0.7

Separate electrical source required for continuous operation of single-phase heater pads for Liebert Lee-Temp.

Table 34 Drycooler & pump package - 35°C (95°F) ambient

Tonnage	3 Ton			5 Ton		
	200	230	380/415	200	230	380/415
Glycol	Drycooler & Pump					
DSF Model	092	092	092	109	109	109
Pump Hp	1-1/2	1-1/2	1-1/2	1-1/2	1-1/2	1-1/2
FLA	9.6	9.6	4.6	9.6	9.6	4.6
GLYCOOL	Drycooler & Pump					
DSO Model	-	-	-	109	109	109
Pump Hp	-	-	-	1-1/2	1-1/2	1-1/2
FLA	-	-	-	9.6	9.6	4.6

1. Pump and drycooler powered from same 3 phase feeder.

Table 35 Drycooler only - 35°C (95°F) ambient

Tonnage	3 Ton			5 Ton		
	200	230	380/415	200	230	380/415
Glycol	Drycooler & Pump					
DSF Model	092	092	092	109	109	109
FLA	4.0	4.0	1.8	4.0	4.0	1.8
GLYCOOL	Drycooler & Pump					
DSO Model	-	-	-	109	109	109
FLA	-	-	-	4.0	4.0	1.8

1. Drycooler powered from same 3 phase feeder as pumps.

Table 36 Pumps, three-phase

hp	Voltage (3 Phase - 50Hz)	
		380/415
1-1/2	FLA	2.7
2	FLA	3.6

21.0 GUIDE SPECIFICATIONS—NOMINAL 3 OR 5 TON ENVIRONMENTAL CONTROL SYSTEM

1.0 GENERAL

1.1 Summary

These specifications describe requirements for an environmental control system. The system shall be designed to maintain temperature and relative humidity conditions within the room. The manufacturer shall design and furnish all equipment to be fully compatible with heat dissipation requirements of the site.

1.2 Design Requirements

The environmental control system shall be a Liebert Challenger 3000 factory-assembled unit. Standard 60Hz units shall be CSA-certified to the harmonized U.S. and Canadian product safety standard, CSA C22.2 No 236/UL 1995 for “Heating and Cooling Equipment” and are marked with the CSA c-us logo. It shall be specifically designed for service from the front of the unit. The system shall be designed for draw-through air arrangement to insure even air distribution to the entire face area of the coil.

Each system shall be capable of handling ____ CFM (CMH) at ____ inches (mm) of water external static pressure with (down discharge air flow) (up discharge air flow with front return or up discharge airflow with rear return) pattern. It shall have a total cooling capacity of ____ BTU/HR (kW), sensible cooling capacity of ____ BTU/HR (kW), based on the entering air condition of °F (°C) dry bulb and ____ °F (°C) wet bulb. These units are to be supplied with ____ V, ____ phase, ____ Hz power supply. The humidifier shall have a capacity of ____ lb/hr (kg/h). Reheat shall have a capacity of ____ BTU/HR (kW). The main fan shall be ____ hp (kW).

1.3 Submittals

Submittals shall be provided with the proposal and shall include: Single-Line Diagrams; Dimensional, Electrical, and Capacity data; Piping and Electrical Connection Drawings.

2.0 PRODUCT

2.1 All Systems

2.1.1 Cabinet and Frame Construction

The frame shall be constructed of MIG welded tubular and formed steel. All frame components shall be finished in a black, powder-coat finish to protect against corrosion. The exterior panels shall be (20 gauge)/(18 gauge) steel and shall be powder coated with ____ color paint. The panels shall be insulated with a minimum 1 in. (25.4mm), 1-1/2 lb. (0.68 kg) density fiber insulation. Front and side panels shall have captive, 1/4 turn fasteners.

The cabinet shall be designed so that all components are serviceable and removable from the front of the unit.

2.1.2 Fan and Motor Section

The fan shall be the centrifugal type, double width, double inlet. The shaft shall be heavy duty steel with self-aligning ball bearings with minimum life span of 100,000 hours.

The fan motor shall be 1750 rpm and mounted on an adjustable base. The drive package shall be sized for 200% of the fan motor horsepower, and equipped with an adjustable motor pulley. The fan/motor assembly shall be mounted on (vibration isolators) (solid base). The fan shall be located to draw air over the coil to ensure even air distribution and maximum coil performance.

High Efficiency Motor (Optional)

The fan motor shall be a ____ hp (kW) high efficiency motor with a full load efficiency of ____ %.

2.1.3 Filter

The filter shall be ____ inches (mm) thick and rated not less than MERV _____ (8 or 11) efficiency based on ASHRAE 52.2-2007.

Prefilter (Optional)

The prefilter shall be 2 in. (50.8mm) thick with an efficiency of MERV 8 based on ASHRAE 52.2-2007.

2.1.4 Liebert iCOM® Microprocessor Control With Small Graphic Display

The Liebert iCOM control processor shall be microprocessor based with a 128 x 64 dot matrix graphic front monitor display and control keys for user inputs mounted in an ergonomic, aesthetically pleasing housing. The display & housing shall be viewable while the unit panels are open or closed. The controls shall be menu driven. The display shall be organized into three main sections: User Menus, Service Menus and Advanced Menus. The system shall display user menus for: active alarms, event log, graphic data, unit view/status overview (including the monitoring of room conditions, operational status in % of each function, date and time), total run hours, various sensors, display setup and service contacts. A password shall be required to make system changes within the service menu. Service menus shall include: setpoints, standby settings (lead/lag), timers/sleep mode, alarm setup, sensor calibration, maintenance/wellness settings, options setup, system/network setup, auxiliary boards and diagnostics/service mode. A password shall be required to access the advanced menus, which include the factory settings and password menus.

The Liebert iCOM unit control shall be factory-set for Intelligent Control which uses “fuzzy logic” and “expert systems” methods. Proportional and Tunable PID shall also be user selectable options. Internal unit component control shall include the following:

Compressor Short Cycle Control - Prevents compressor short-cycling and needless compressor wear.

System Auto Restart - The auto restart feature will automatically restart the system after a power failure. Time delay is programmable.

Sequential Load Activation - On initial startup or restart after power failure, each operational load is sequenced with a minimum of one second delay to minimize total inrush current.

Econ-O-Coil Flush Cycles - Econ-O-Coils are flushed periodically to prevent a buildup of contaminants.

Predictive Humidity Control - Calculates the moisture content in the room and prevents unnecessary humidification and dehumidification cycles by responding to changes in dew point temperature.

The Liebert iCOM control shall be compatible with all Liebert remote monitoring and control devices. Options are available for BMS interface via MODbus, BACNet and SNMP.

The User Menus Shall be Defined as Follows:

Active Alarms: Unit memory shall hold the 200 most recent alarms with time and date stamp for each alarm.

Event Log: Unit memory shall hold the 400 most recent events with ID number, time and date stamp for each event.

Graphic Data View: Eight graphic records shall be available: return air temperature, return air humidity, supply air temperature, outdoor temperature and four custom graphs.

Unit View - Status Overview: Simple or Graphical “Unit View” summary displays shall include temperature and humidity values, active functions (and percent of operation) and any alarms of the host unit.

Total Run Hours: Menu shall display accumulative component operating hours for major components including compressors, Econ-O-Coil (FC), fan motor, humidifier and reheat.

Various Sensors: Menu shall allow setup and display of optional custom sensors. The control shall include four customer accessible analog inputs for sensors provided by others. The analog inputs shall accept a 4 to 20 mA signal. The user shall be able to change the input to 0 to 5VDC or 0 to 10VDC if desired. The gains for each analog input shall be programmable from the front display. The analog inputs shall be able to be monitored from the front display.

Display Setup: Customer shall pre-select the desired grouping of display languages at the time of the order from the following choices:

- Group 1: English, French, Italian, Spanish, German
- Group 2: English, Russian, Greek
- Group 3: English, Japanese, Chinese, Arabic

Service Contacts: Menu shall allow display of local service contact name and phone number.

The Service Menus Shall be Defined as Follows:

Setpoints: Menu shall allow setpoints within the following ranges:

- Temperature Setpoint 65-85°F (18-29°C)*
- Temperature Sensitivity +1-10°F (0.6-5.6°C)
- Humidity Setpoint 20-80% RH*
- Humidity Sensitivity 1-30% RH
- High Temperature Alarm 35-90°F (2-32°C)
- Low Temperature Alarm 35-90°F (2-32°C)
- High Humidity Alarm 15-85% RH
- Low Humidity Alarm 15-85% RH

* The microprocessor may be set within these ranges, however, the unit may not be able to control to extreme combinations of temperature and humidity.

Standby Settings/Lead-Lag: Menu shall allow planned rotation or emergency rotation of operating and standby units.

Timers/Sleep Mode: Menu shall allow various customer settings for turning on/off unit.

Alarm Setup: Menu shall allow customer settings for alarm notification (audible/local/remote). The following alarms shall be available:

- High Temperature
- Low Temperature
- High Humidity
- Low Humidity
- Compressor Overload (Optional)
- Main Fan Overload (Optional)
- Humidifier Problem
- High Head Pressure
- Change Filter
- Fan Failure
- Low Suction Pressure
- Unit Off

Audible Alarm: The audible alarm shall annunciate any alarm that is enabled by the operator.

Common Alarm: A programmable common alarm shall be provided to interface user selected alarms with a remote alarm device.

Remote Monitoring: All alarms shall be communicated to the Liebert monitoring system with the following information: Date and time of occurrence, unit number and present temperature and humidity.

Sensor Calibration: Menu shall allow unit sensors to be calibrated with external sensors.

Maintenance/Wellness Settings: Menu shall allow reporting of potential component problems before they occur.

Options Setup: Menu shall provide operation settings for the installed components.

System/Network Setup: Menu shall allow Unit-to-Unit (U2U) communication and setup for teamwork modes of operation (up to 32 units).

Teamwork Modes of Operation: Saves energy by preventing operation of units in opposite modes multiple units.

Auxiliary Boards: Menu shall allow setup of optional expansion boards.

Diagnostics/Service Mode: The Liebert iCOM® control shall be provided with self-diagnostics to aid in troubleshooting. The microcontroller board shall be diagnosed and reported as pass/not pass. Control inputs shall be indicated as on or off at the front display. Control outputs shall be able to be turned on or off from the front display without using jumpers or a service terminal. Each control output shall be indicated by an LED on a circuit board.

Advanced Menus

Factory Settings: Configuration settings shall be factory-set based on the pre-defined component operation.

Change Passwords: Menu shall allow new passwords to be set or changed.

Liebert iCOM Microprocessor Control With Large Graphic Display (Optional)

The Liebert iCOM unit control with large graphic display shall include all of the features as the Liebert iCOM with small graphic display, except that it includes a larger graphical display and shall include the additional features of: “System View,” Spare Parts List, Unit Diary.

The Liebert iCOM control processor shall be microprocessor based with a 320x240 dot matrix graphic front monitor display panel and control keys for user inputs mounted in an ergonomic, aesthetically pleasing housing.

System View - Status Overview: “System View” shall display a summary of operation for the total number of operating units within a Unit-to-Unit (U2U) configuration.

Spare Parts List: Menu shall include a list of critical spare parts, their quantity and part numbers.

Unit Diary: Menu shall include a free field area within the unit memory where unit history may be stored for reference.

Liebert iCOM Wall Mount Large Graphic Display (Optional)

The Liebert iCOM Large Graphic Display Kit shall include an ergonomic, aesthetically pleasing housing, a 320x240 dot matrix graphic display and a 120V power supply. The Wall Mount Large Graphic Display shall be used to allow remote location of a “System View” display and all features of the Large Graphic User, Service and Advanced menus for use with Liebert iCOM-controlled products connected for Unit-to-Unit (U2U) communications.

2.1.5 Infrared Humidifier (Standard)

The humidifier shall be of the infrared type consisting of high intensity quartz lamps mounted above and out of the water supply. The evaporator pan shall be stainless steel and arranged to be serviceable without disconnecting water supply lines, drain lines or electrical connections. The complete humidifier section shall be pre-piped ready for final connection. The infrared humidification system shall use bypass air to prevent over-humidification of the controlled space. The auto flush system shall automatically flush deposits from the humidifier pan. The system shall be field adjustable to change the cycle time to suit local water conditions. The humidifier shall have a capacity of ____ lb/hr (kg/h).

2.1.6 Steam Generating Humidifier (Optional)

The environmental control system shall be equipped with a steam generating humidifier that is controlled by the Liebert iCOM microprocessor control system. It shall be complete with disposable canister, all supply and drain valves, steam distributor, and electronic controls. The need to change canister shall be annunciated on the Liebert iCOM control panel. The humidifier shall have a capacity of ____ lb/hr (kg/h).

2.1.7 Electric Reheat (Standard)

The low-watt density, 304/304, stainless steel, finned-tubular electric reheat coils shall be capable of maintaining room dry bulb conditions when the system is calling for dehumidification. The reheat section shall include UL approved safety switches to protect the system from overheating. The capacity of the reheat coils shall be ____ BTU/HR (kW), ____ kW, controlled in ____ stage(s).

2.1.8 Hot Water Reheat (Optional on Chilled Water Units Only)

The hot water reheat coil shall have copper tubes and aluminum fins with a capacity of ____ BTU/HR (kW) when supplied with ____ °F (°C) entering water temperature at ____ GPM (l/s) flow rate. Maximum pressure drop shall be ____ PSI (kPa). The control system shall be factory-pre-piped with a 2-way motorized control valve with cleanable Y-strainer.

2.1.9 SCR Electric Reheat (Optional)

The SCR (Silicon Controlled Rectifier) controller shall proportionally control the stainless steel reheats to maintain the selected room temperature. The SCR controller provides precise temperature control, and the lower element temperature improves heater life. The capacity of the reheat coils shall be ____ BTU/HR (kW). Available on direct expansion units with standard scroll only.

2.1.10 Floor Stand (Optional)

The floor stand shall be constructed of a heliarc-welded tubular steel frame. The floor stand shall be coated using an autodeposition process to protect against corrosion. The floor stand shall have adjustable legs with vibration isolation pads. The floor stand shall be: (9 in. [23cm]), (12 in. [30cm]), (15 in. [38cm]), (18 in. [46cm]), (21 in. [53cm]), (24 in. [61cm]) high.

2.1.11 Turning Vane (Optional)

The turning vane shall be designed to mount in the factory-supplied floor stand and direct air either to the front or rear of the unit.

2.1.12 Plenum (Optional)

The unit shall be supplied with a (2 way) (3 way) (4 way) (ducted) air discharge plenum. The plenum shall be 18 in. (457mm) high, insulated and powder painted the same color as the room unit.

2.1.13 Disconnect Switch, Locking Type (Optional)

The manual disconnect switch shall be mounted in the high voltage section of the electrical panel. The switch shall be accessible from the outside of the unit with the door closed, and prevent access to the high voltage electrical components until switched to the Off position. The locking disconnect switch shall provide 65kA SCCR for 60Hz models and 5kA SCCR for 50Hz models.

2.1.14 Disconnect Switch, Non-Locking Type (Optional)

The manual disconnect switch shall be mounted in the high voltage section of the electrical panel. The switch shall be accessible with the door closed. The non-locking disconnect switch shall be available for 50Hz models only and shall provide 5kA SCCR protection.

2.1.15 Remote Sensors (Optional)

The unit shall be supplied with remote temperature and humidity sensors. The sensors shall be connected to the unit by a (30 ft. [9m]), (60 ft. [18m]), (90 ft. [27m]), (120 ft. [36m]), (150 ft. [45m]) shielded cable. Supply Temp Thermistor is an option for chilled water units.

2.1.16 High Temperature Sensor (Optional)

The high temperature sensor shall immediately shut down the system when high temperatures are detected. The high temperature stat shall be mounted in the electrical panel with the sensing element in the return air.

2.1.17 Smoke Sensor (Optional)

The smoke sensor shall sample the return air, shut down the unit upon activation and send visual and audible alarms. Dry contacts shall be available for a remote customer alarm. This smoke sensor is not intended to function as or replace any room smoke detection system that may be required by local or national codes.

2.1.18 Condensate Pump (Optional)

The condensate pump shall have the capacity of ____ GPH (l/h) at ____ ft. (m) head @ ____ V - ____ Hz. It shall be complete with dual integral float switch, pump, motor assembly and reservoir. The condensate pump shall be factory-installed on upflow units and field-installed on downflow units. The secondary float shall send an alarm signal to the Liebert iCOM®, which will display the condensate pump alarm and shut down the unit upon a high water condition.

2.2 Direct Expansion Self-Contained Systems

Direct Expansion Coil

The evaporator coil shall have ____ sq.ft. (sq. m) face area, ____ rows deep. It shall be configured as (A) (V) frame and be constructed of copper tubes and aluminum fins and have a maximum face velocity of ____ ft. per minute (m/s) at ____ CFM (CMH). The coil shall be provided with a stainless steel drain pan.

Refrigeration System (Standard)

The refrigeration system shall consist of a high efficiency scroll compressor, hot gas bypass, pressure safety switches, externally equalized expansion valve, filter drier, refrigerant sight glass, moisture indicator and R407C refrigerant.

The compressor shall be scroll-type. The compressor shall be suction gas-cooled motor, vibration isolators, thermal overloads, automatic reset high pressure switch with lockout after three failures, rotalock service valves, pump down low pressure transducer, suction line strainer and a maximum operating speed of 3500 rpm.

Refrigeration System (Optional)

The refrigeration system shall consist of a high efficiency digital scroll compressor, pressure safety switches, externally equalized expansion valve, filter drier, refrigerant sight glass, moisture indicator and R407C refrigerant.

The compressor shall be scroll-type with a variable capacity operation capability. Compressor solenoid valve shall unload the compressor and allow for variable capacity operation, 20 - 100%. The compressor shall be suction gas-cooled motor, vibration isolators, thermal overloads, automatic reset high pressure switch with lockout after three failures, rotalock service valves, pump down low pressure transducer, suction line strainer, and a maximum operating speed of 3500 rpm. Consult factory for 575V availability.

2.2.1 Air-Cooled Self-Contained Systems

Crankcase Heater and Discharge Check Valve

A crankcase heater and discharge check valve shall be provided for additional system protection from refrigerant migration during Off cycles.

Propeller Fan Condenser

The Emerson-manufactured air-cooled condenser shall be the low profile, slow speed, direct-drive, propeller-fan type. The condenser cabinet shall be constructed of aluminum and shall contain (an aluminum microchannel) (a copper tube/aluminum fin) coil(s) with an integral electric control panel. The system shall be designed for ____ °F (°C) ambient. The air-cooled condenser shall have a ____ V, ____ phase, ____ Hz power supply.

2.3 Liebert MC™ Condenser

The Emerson-manufactured air-cooled condenser shall be the low profile, slow speed, direct-drive, propeller-fan type. The heat exchanger shall be an aluminum microchannel coil assembly. Microchannel coils shall provide superior heat transfer, reduce air-side pressure drop, increase energy efficiency and significantly reduce the system refrigerant volume required. The coil assembly shall be piped and mounted within aluminum panels, with external copper pipe connections. An electrical control panel shall be factory wired and mounted to the condenser. The system shall be designed for ____ °F (°C) ambient. The air-cooled condenser shall have a ____ V, ____ phase, 60Hz power supply.

2.3.1 Liebert MC™ with Premium/EC Fan Control

The Liebert MC Premium/EC Fan Control system shall include a Premium Control board, EC fan/motor assembly operating from 0% to 100% motor rpm based on head pressure, refrigerant pressure transducers, ambient thermistor, liquid line thermistor, internal motor overload protection and electrical control circuit, factory-wired in the control panel. Fan(s) on common refrigerant circuit shall operate in synchronous speed when that circuit is active. Dual circuit condensers shall operate fans to meet airflow needs of each circuit independent of the other. EC fans and fan operating techniques shall provide reduced maximum sound levels. Various methods shall be available to match indoor unit type, maximum outdoor design ambient and maximum sound requirements. This system permits operation at temperatures as low as -30°F (-34.4°C).

The Liebert MC Premium/EC Control system shall provide positive startup and operation in ambient temperature as low as -30°F (-34.4°C). The air-cooled condenser shall have a ____ V, ____ ph, 60Hz power supply.

2.3.2 Liebert MC with Liebert Lee-Temp™ Head Pressure Control (Optional)

The Liebert MC condenser with Liebert Lee-Temp flooded receiver shall allow startup and positive head pressure control with ambient temperatures as low as -30°F (-34.4°C). The Liebert MC condenser shall contain all components as the Liebert MC with Premium/EC Fan control and shall be factory-programmed to adjust fan speed based on outdoor ambient and condensing pressure as needed. The Liebert Lee-Temp package shall include: insulated receiver, pressure relief valve for each circuit, head pressure three-way control valve and rotalock valve for isolating the refrigerant charge. The Liebert Lee-Temp receiver shall be factory-insulated and mounted ready for field connection to the air-cooled condenser. The Liebert Lee-Temp heater shall be 150W and shall require a separate power supply of (115) (230) ____ V, single phase, 60Hz.

2.3 Liebert Fin/Tube Condenser

2.3.1 Variable Frequency Drive (VFD) Condenser (1-4 Fan)

The VFD condenser shall have a variable frequency drive controlling one inverter duty, variable speed motor and On/Off fan motor(s) (for multiple fan models only) to vary the airflow across the coil. The VFD shall use one or more pressure transducers to sense refrigerant pressure to adjust fan speed to a positive head pressure control range. The inverter duty motor shall have permanently lubricated ceramic ball bearings. The Liebert variable frequency drive control system shall provide overload protection for the variable speed motor. On/Off fan motor(s) shall have individual internal overload protection and shall be controlled by ambient air thermostat(s) increasing/decreasing condenser capacity in stepped increments. Motors shall have a TEAO enclosure and a full speed of 1140Hz @ 60Hz (950Hz @ 50Hz). An internal Surge Protective Device (SPD) shall protect the VFD from power surges. Alarm contacts for the SPD and VFD shall be provided for monitoring of system components.

The VFD Control system shall provide positive startup and operation in ambient temperature as low as -20°F (-28.9°C). The air-cooled condenser shall have a ____ V, ____ ph ____ Hz power supply.

2.3.2 Fan Speed Control (FSC) Condenser (1 Fan)

The FSC condenser shall have a fan speed controller sensing refrigerant pressure and varying the speed of a FSC duty motor. Motor shall be single-phase and include built-in overload protection. Motor shall have an ODP enclosure and have a full speed of 1100Hz @ 60Hz (920Hz @ 50Hz).

The fan speed control system shall provide positive startup and operation in ambient temperature as low as -20°F (-28.9°C). The air-cooled condenser shall have a ____ V, 1 ph, ____ Hz power supply.

2.3.3 Fan Speed Control (FSC) Condenser (2, 3 or 4 Fans)

The FSC condenser shall have a fan speed controller sensing refrigerant pressure and varying the speed of an FSC duty motor. Additional fan motors shall be fixed speed, cycled On/Off by ambient air thermostats to further vary the airflow across the coil. The FSC motor shall be single-phase and include built-in overload protection. FSC motor shall have an ODP enclosure and a full speed of 1100Hz @ 60Hz (920Hz @ 50Hz). The fixed speed motors shall be three-phase and have individual internal overload protection. Fixed speed motors shall have a TEAO enclosure and a full speed of 1140Hz @ 60Hz (950Hz @ 50Hz).

The fan speed control system shall provide positive startup and operation in ambient temperature as low as -20°F (-28.9°C). The air-cooled condenser shall have a ____ V, 3 ph, ____ Hz power supply.

2.3.4 Liebert Lee-Temp™ Condensers (All Fan Quantities)

Liebert Lee-Temp condensers shall consist of fixed speed fan motor(s), controlled by internal contactor(s). Fans shall run full speed whenever compressors are running. The fixed speed motors shall be three-phase and provide individual internal overload protection. Fixed speed motors shall have a TEAO enclosure and a full speed of 1140Hz @ 60Hz (950Hz @ 50Hz).

Each refrigerant circuit shall have an insulated, heated receiver tank with sight glasses, pressure relief valve, rotalock valve for refrigerant charge isolation and piping assembly with head pressure operated 3-way valve and check valve. Components shall be field-assembled to the condenser. The 3-way valve shall sense refrigerant head pressure and adjust the flooding charge in the condenser coil to adjust the condenser heat rejection capacity. The Liebert Lee-Temp heater shall be (150W) (300W), include an integral thermostat to maintain refrigerant temperature at a minimum of 85°F (29°C) and shall require a separate power supply of (208/230-1-60) (120-1-60) (200/230-1-50) (110-1-50).

This Liebert Lee-Temp control system shall allow system startup and positive head pressure control with ambient temperatures as low as -30°F (-34.4°C).

2.3.5 Liebert Quiet-Line™ Condensers (All Fan Quantities)

Liebert Quiet-Line condensers shall consist of fixed speed fan motor(s), controlled by internal contactor(s). One fan per refrigerant circuit shall run at full speed with the compressor(s). Additional fan motors may be full speed or cycled based on ambient temperatures. Motors shall have a TEAO enclosure, provide individual overload protection and have a full speed of 570rpm @ 60Hz (475rpm @ 50Hz).

Each refrigerant circuit shall have an insulated, heated receiver tank with sight glasses, pressure relief valve, rotalock valve for refrigerant charge isolation and piping assembly with head pressure operated 3-way valve and check valve. Components shall be field assembled to the condenser. The 3-way valve shall sense refrigerant head pressure and adjust the flooding charge in the condenser coil to adjust the condenser heat rejection capacity. The Liebert Lee-Temp heater shall be (150W) (300W), include an integral thermostat to maintain refrigerant temperature at a minimum of 85°F (29°C) and requires a separate power supply of (208/230-1-60) (120-1-60) (200/230-1-50) (110-1-50).

This system shall allow system startup and positive head pressure control with ambient temperatures as low as -30°F (-34.4°C).

2.3.6 Piggyback Condenser (Optional)

The system shall be supplied with a piggyback condenser (PB). The condenser shall be constructed of steel with frame coated using the autophoretic® process, and panels powder coated to protect against corrosion. The coil shall be copper tube with aluminum fins. The heavy duty fan shall be the centrifugal type, double width, double inlet. The 1750 rpm (1450 rpm @ 50 Hz) fan motor shall be mounted on an adjustable base, and equipped with an adjustable motor pulley. A Liebert Lee-Temp head pressure control system shall be integral with the unit. The system shall be designed for -30°F (-34.4°C) ambient. The air-cooled condenser shall have a _____ V, 3 phase, _____ Hz power supply.

2.3.7 Water- or Glycol-Cooled Self-Contained Systems

Indoor Unit Condenser

The water/glycol system shall be equipped with a coaxial condenser having a total pressure drop of _____ ft. of water (kPa) and a flow rate of _____ GPM (l/s) with _____ °F (°C) entering water/glycol temperature.

2-Way Water Regulating Valve with Bypass (Standard)

The condenser circuit shall be pre-piped with a head-pressure actuated 2-way regulating valve with bypass.

3-Way Water Regulating Valve (Optional)

The condenser circuit shall be pre-piped with a head pressure actuated 3-way regulating valve.

Motorized Ball Valve (With Optional Digital Scroll Compressor)

Discharge pressure on digital scroll units shall be controlled by a motorized ball valve. During unloaded operation, the pressure changes during each digital cycle could result in excessive repositions with a pressure operated water regulating valve. The control algorithm for the motorized ball valve uses an intelligent sampling rate and adjustable pressure thresholds to reduce valve repositions. The valve assembly consists of the brass valve, linkage and actuator. Motorized ball valve standard design pressure is 400psi (2758kPa).

Design Pressure

The condenser water/glycol circuit with a water regulating valve and standard scroll compressor shall be designed for a pressure of (150 PSI [1034 kPa]) (350psi [2413 kPa]). The condenser water/glycol circuit with a motorized ball valve and digital scroll compressor shall be designed for a pressure of 400psi (2758kPa).

Crankcase Heater (Optional)

A crankcase heater is provided to prevent the migration of refrigerant to the compressor during off cycles.

Hot Gas Reheat (Optional)

The complete hot gas reheat system shall include a copper tube, aluminum fin coil, three-way solenoid valve, and refrigerant check valve. The capacity of the coil shall be _____ BTU/HR (kW).

Outdoor Unit

Propeller Fan Drycooler (Standard)

The Emerson-manufactured drycooler shall be the low profile, slow speed, direct drive propeller fan type. The drycooler shall be constructed of aluminum and contain a copper tube aluminum fin coil with an integral electric control panel. The drycooler shall be designed for _____ °F (°C) ambient.

Single Glycol Pump Package (Standard)

This system shall be provided with a centrifugal pump mounted in a weatherproof and vented enclosure. The pump shall be rated for _____ GPM (l/s) at _____ ft. of head (kPa), and operate on _____ V, 3 phase, _____ Hz.

Dual Glycol Pump Package (Optional)

The dual pump package shall include pumps, enclosure, and field mounted flow switch. The pumps shall be wired to the drycooler control box which includes a lead/lag switch for the pumps. The standby pump shall automatically start upon failure of the lead pump. Each pump shall be rated _____ for GPM (l/s) at _____ feet of head (kPa).

2.3.8 GLYCOOL Self-Contained Systems

GLYCOOL Coil

The GLYCOOL coil shall be constructed of copper tubes and aluminum fins and be located upstream of the evaporator coil. The GLYCOOL coil shall be designed for closed-loop applications using properly treated glycol solutions. The coil shall be rated at _____ BTU/HR (kW) sensible cooling capacity with a _____ F (°C) entering glycol solution temperature. The GLYCOOL coil shall require _____ GPM (l/s) and the total unit pressure drop shall not exceed _____ feet of water (kPa) when in the free-cooling mode.

3-Way GLYCOOL Valve

The GLYCOOL coil shall be equipped with a fully proportional 3-way control valve. This motorized control valve shall control the amount of flow to the GLYCOOL coil and maintain constant temperature and relative humidity.

Glycol Condenser

The glycol system shall be equipped with a coaxial condenser having a total pressure drop of _____ feet of water (kPa) and a flow rate of _____ GPM (l/s), with _____ °F (°C) entering 40% ethylene glycol temperature.

3-Way Water Regulating Valve (Standard)

The condenser circuit shall be pre-piped with a head pressure actuated 3-way water regulating valve.

Motorized Ball Valve (With Optional Digital Scroll Compressor)

Discharge pressure on digital scroll units shall be controlled by a motorized ball valve. During unloaded operation, the pressure changes during each digital cycle could result in excessive repositions with a pressure operated water regulating valve. The control algorithm for the motorized ball valve uses an intelligent sampling rate and adjustable pressure thresholds to reduce valve repositions. The valve assembly consists of the brass valve, linkage and actuator.

Design Pressure

The GLYCOOL coil/condenser circuit with a water regulating valve and standard scroll compressor shall be designed for a pressure of (150PSI [1034 kPa]) or (300PSI [2069 kPa]). The GLYCOOL coil/condenser circuit with a motorized ball valve and digital scroll compressor shall be designed for a pressure of 300psi (2068kPa).

Comparator Circuit

The system shall be equipped with a Liebert iCOM[®] microprocessor-controlled comparator sensor that permits free-cooling operation whenever entering glycol temperature is below return-air temperature.

Propeller Fan Drycooler (Standard)

The Emerson-manufactured drycooler shall be the low profile, slow speed, direct drive propeller fan type. The drycooler shall be constructed of aluminum and contain a copper tube aluminum fin coil with an integral electric control panel. The drycooler shall be designed for _____ °F (°C) ambient.

Single Glycol Pump Package (Standard)

This system shall be provided with a centrifugal pump mounted in a weatherproof and vented enclosure. The pump shall be rated for _____ GPM (l/s) at _____ ft. of head (kPa), and operate on _____ V, 3 phase, _____ Hz.

Dual Glycol Pump Package (Optional)

The dual pump package shall include pumps, enclosure, and field mounted flow switch. The pumps shall be wired to the drycooler control box which includes a lead/lag switch for the pumps. The standby pump shall automatically start upon failure of the lead pump. Each pump shall be rated for _____ GPM (l/s) at _____ feet of head (kPa).

2.4 Direct Expansion Split Systems

Direct Expansion Coil

The evaporator coil shall have _____ sq.ft. (sq. m) face area, _____ rows deep. It shall be configured as (A) (V) frame and be constructed of copper tubes and aluminum fins and have a maximum face velocity of _____ ft. per minute (m/s) at _____ CFM (CMH). The coil shall be provided with a stainless steel drain pan.

Refrigeration System

The refrigeration system shall consist of a high-efficiency scroll compressor, pressure safety switches, externally equalized expansion valve, filter dryer, a refrigerant sight glass, moisture indicator and R407C refrigerant.

Refrigerant Line Sets (Optional)

Pre-charged refrigerant line sets for 3-ton models shall be provided by Emerson in proper lengths for application. Line set length shall be _____ feet (m) up to 60ft. (18.25m) of total length maximum or two line sets in series.

Sweat Adapters

Sweat adapters shall be available as an option for 3-ton units.

2.4.1 Air-Cooled Split Systems

Centrifugal Fan Condensing Unit

The condenser coil shall be constructed of copper tubes and aluminum fins. The condensing unit shall be factory-assembled, charged with refrigerant and sealed.

Components shall include a standard scroll compressor, high-pressure switch, Liebert Lee-Temp™ refrigerant receiver, head pressure control valve and liquid line solenoid valve.

The condensing unit shall be designed for 95°F (35°C) ambient and be capable of operation to -30°F (-34°C) ambient.

A hot gas bypass circuit shall be provided to reduce compressor cycling and improve operation under low load conditions.

The condenser fan shall be designed for _____ CFM (CMH) at _____ inches (mm) external static pressure.

Disconnect (Optional)

A factory-installed non-fused disconnect switch shall allow the unit to be turned Off for maintenance.

3-Ton Models

The condensing module shall be capable of being connected to the evaporator section using pre-charged refrigerant line sets up to 60 ft. (18.25m) of total length, maximum or two line sets in series. No brazing, dehydration, or charging shall be required. The fan/motor assembly shall be direct drive.

5-Ton Models

The fan/motor assembly shall be belt drive. Condensing unit must be hard piped with the evaporator. Sweat adapters are shipped loose with all 5 ton evaporators for use on the 5 ton condensing units.

Propeller Fan Condensing Unit

The condenser coil shall be constructed of copper tubes and aluminum fins with a direct drive propeller type fan and shall include a standard scroll compressor, high pressure switch, Liebert Lee-Temp receiver, head pressure control valve, and liquid line solenoid valve. All components shall be factory-assembled, charged with R407C refrigerant and sealed. No brazing, dehydration, or charging shall be required. Condensing unit shall be designed for 95°F (35°C) ambient and be capable of operation to -30°F (-34.4°C).

A hot gas bypass circuit shall be provided to reduce compressor cycling and improve operation under low load conditions.

Quiet-Line Models (Optional)

The condensing unit shall be designed to operate at a sound level less than 58 dBA.

High Ambient Models (Optional)

The outdoor condensing unit shall be designed for design ambient operation of 105°F (40.6°C).

3-Ton Models

The condensing module shall be capable of being connected to the evaporator section using pre-charged refrigerant line sets up to 60 ft. (18.25m) of total length, maximum or two line sets in series. No brazing, dehydration, or charging shall be required.

5-Ton Models

Condensing unit must be hard piped with the evaporator. Sweat adapters are shipped loose with all 5-ton evaporators for use on the 5-ton condensing units.

2.4.2 Water- or Glycol-Cooled Split Systems

Water- or Glycol-Cooled Condensing Unit

The water/glycol condensing unit shall be equipped with a coaxial condenser having a total system pressure drop of _____ ft. of water (kPa) and a flow rate of _____ GPM (l/s) with _____ °F (°C) entering water/glycol temperature.

Components shall include scroll compressor and high-pressure switch. The condensing unit shall be factory-charged with R-407C refrigerant.

The condenser circuit shall be pre-piped with a (2-way) (3-way) regulating valve which is head-pressure actuated.

The condenser water/glycol circuit shall be designed for a static operating pressure of (150PSI [1034 kPa]) or (350PSI [2413 kPa]).

A hot gas bypass circuit shall be provided to reduce compressor cycling and improve operation under low load conditions.

Disconnect (Optional)

Factory-installed non-fused disconnect switch allows unit to be turned off for maintenance.

3-Ton Models

The condensing module shall be capable of being connected to the evaporator section using pre-charged refrigerant line sets up to 60 ft. (18.25m) of total length, maximum or two line sets in series. No piping, brazing, dehydration, or charging shall be required.

5-Ton Models

Condensing unit must be hard piped with the evaporator. Sweat adapters are shipped loose with all 5 ton evaporators for use on the 5 ton condensing units.

Propeller Fan Drycooler

The Emerson-manufactured drycooler shall be the low profile, slow speed, direct drive propeller fan type. The drycooler shall be constructed of aluminum and contain a copper tube aluminum fin coil with an integral electric control panel. The drycooler shall be designed for _____ °F (°C) ambient.

Single Glycol Pump Package (Standard)

This system shall be provided with a centrifugal pump mounted in a weatherproof and vented enclosure. The pump shall be rated for GPM (l/s) at _____ ft. of head (kPa) and shall operate on _____ V, 3 phase, _____ Hz.

Dual Glycol Pump Package (Optional)

The dual pump package shall include pumps, enclosure, and field mounted flow switch. The pumps shall be wired to the drycooler control box which includes a lead/lag switch for the pumps. The standby pump shall automatically start upon failure of the lead pump. Each pump shall be rated for _____ GPM (l/s) at _____ feet of head (kPa).

2.5 Chilled Water Self-Contained Systems

Chilled Water Coil

The cooling coil shall have a minimum of ____ sq. ft. (sq. m) face area, ____ rows deep. The coil shall be controlled by a modulating control valve. The chilled water coil shall be designed for closed-loop applications using properly maintained water. It shall be configured as an (A) (V) frame and be constructed of copper tubes and aluminum fins and have a maximum face velocity of ____ ft. per minute (m/s) at ____ CFM (CMH). The water circuit shall be designed to distribute water into the entire coil face area. The coil shall be supplied with ____ °F (°C) entering water temperature, with a ____ °F (°C) temperature rise. The coil shall be supplied with ____ GPM (m/s) of chilled water and the pressure drop shall not exceed ____ PSI (kPa). The coil assembly shall be mounted in a stainless steel condensate drain pan.

3-Way Chilled Water Valve (Standard)

The water circuit shall include a 3-way modulating valve. The Liebert iCOM® microprocessor control shall position the valve in response to room conditions. Cooling capacity will be controlled by bypassing chilled water around the coil.

2-Way Chilled Water Valve (Optional)

The water circuit shall include a 2-way modulating valve. The Liebert iCOM microprocessor control shall position the valve in response to room conditions. The minimum close-off pressure of the valve/actuator assembly shall be ____ PSI (kPa).

Design Pressure

The chilled water circuit shall be designed for a pressure of (150PSI [1034kPa]) (400PSI [2758kPa]).

Flow Switch (Optional)

The flow switch shall activate the alarm system should the chilled water supply be interrupted. The switch shall be factory-mounted and wired.

2.6 Unit-to-Unit Connectivity

The Liebert iCOM control shall be capable of being connected to other units via a private network that will allow Unit-to-Unit (U2U) Communications between the connected units.

The following modes of operation shall be selectable for all of the units connected on the network:

Teamwork Mode 1, which works best in small rooms with balanced heat loads. This mode does not operate based on the most demanding unit on the network. The return temperature and humidity sensor readings of all units in operation (fan On) are averaged by the master unit, Unit #1, and used for control. The master unit will send the operating requirements to all operating units according to unit numbers, rotated by one unit every 24 hours.

Teamwork Mode 2, which is designed to prevent units within a group from working against each other or “fighting.” It is best applied in large rooms with unbalanced heat loads. In Teamwork Mode 2, all parameters are shared equal to Mode 1, and Unit #1 averages all of the available unit sensor readings on the network to define whether there is a cooling, heating, dehumidification or humidification request.

Standby (Lead/Lag), which allows one or more units to be set as “Running” and “Standby” for activation in case of an alarm. This function also allows the units to be programmed in a rotation to help ensure “Standby” unit operation.

Cascade Operation, which allows additional units to be staged-on based on the temperature or humidity requirement.

2.7 Comprehensive Monitoring Solutions

(For detailed guide specifications on these products, refer to information posted at www.liebert.com)

Liebert SiteScan® Web System

Liebert SiteLink® Module

Liebert Nform®

Liebert IntelliSlot® Cards (Part Numbers)

- Liebert IntelliSlot Unity Card (IS-UNITY_DP)
- Liebert SiteScan Interface Card (IS_485EXI)

Environmental Discrete Outputs Card (ENV-DO)

Universal Monitor

Liebert vNSA™ Network Switch

The Liebert vNSA network switch is designed for connecting multiple Ethernet-ready devices and comes in various models: vNSA8-iCOM, vNSA16-iCOM 13, vNSA8, vNSA16 14. The unit may have a Liebert iCOM display mounted on the front. Models with the Liebert iCOM permit interconnecting cooling units that are equipped with Liebert iCOM controls, allowing the units to communicate and function as a team and facilitating lead/lag operation.

Leak Detection

- Direct Read Module
- Zone Sensor
- Spot Sensor

3.0 EXECUTION

3.1 Installation of Environmental Control Units

3.1.1 General

Install environmental control units in accordance with manufacturer's installation instructions. Install units plumb and level, firmly anchored in locations indicated, and maintain manufacturer's recommended clearances.

3.1.2 Electrical Wiring

Install and connect electrical devices furnished by manufacturer but not specified to be factory-mounted. Furnish copy of manufacturer's electrical connection diagram submittal to electrical contractor.

3.1.3 Piping Connections

Install and connect devices furnished by manufacturer but not specified to be factory-mounted. Furnish copy of manufacturer's piping connection diagram submittal to piping contractor.

3.1.4 Supply and Drain Water Piping

Connect water supply and drains to air conditioning unit. Provide pitch and trap as manufacturer's instructions and local codes require.

3.2 Field Quality Control

Startup environmental control units in accordance with manufacturer's startup instructions. Test controls and demonstrate compliance with requirements.

Technical Support / Service

Web Site

www.liebert.com

Monitoring

liebert.monitoring@emerson.com

800-222-5877

Outside North America: +00800 1155 4499

Single-Phase UPS & Server Cabinets

liebert.upstech@emerson.com

800-222-5877

Outside North America: +00800 1155 4499

Three-Phase UPS & Power Systems

800-543-2378

Outside North America: 614-841-6598

Environmental Systems

800-543-2778

Outside the United States: 614-888-0246

Locations

United States

1050 Dearborn Drive

P.O. Box 29186

Columbus, OH 43229

Europe

Via Leonardo Da Vinci 8

Zona Industriale Tognana

35028 Piove Di Sacco (PD) Italy

+39 049 9719 111

Fax: +39 049 5841 257

Asia

29/F, The Orient Square Building

F. Ortigas Jr. Road, Ortigas Center

Pasig City 1605

Philippines

+63 2 687 6615

Fax: +63 2 730 9572

While every precaution has been taken to ensure the accuracy and completeness of this literature, Liebert Corporation assumes no responsibility and disclaims all liability for damages resulting from use of this information or for any errors or omissions.

© 2013 Liebert Corporation

All rights reserved throughout the world. Specifications subject to change without notice.

© Liebert is a registered trademark of Liebert Corporation.

All names referred to are trademarks

or registered trademarks of their respective owners.

SL-11961_REV3_10-13

Emerson Network Power

Division: Liebert

Web: www.emerson.com