

Liebert® GXT3-10000T230™  
User Manual—10kVA, 50/60 Hz, 230V





---

# TABLE OF CONTENTS

<b>IMPORTANT SAFETY INSTRUCTIONS</b> .....	<b>1</b>
<b>1.0 INTRODUCTION AND SYSTEM DESCRIPTION</b> .....	<b>4</b>
1.1 Device Overview .....	4
1.2 Options .....	5
1.2.1 External Battery Cabinets .....	5
1.2.2 Optional Interfaces .....	5
<b>2.0 UNPACKING THE UPS AND SITE PREPARATION</b> .....	<b>6</b>
2.1 Inspection .....	6
2.2 Required Setup Equipment .....	6
2.3 Unpacking .....	6
2.4 Storage .....	6
2.5 Handling .....	6
2.6 Environmental Conditions .....	7
2.7 Access required .....	7
2.8 Floor/Rack Loading .....	7
2.9 Inventory List .....	7
2.10 Clearance .....	7
2.11 Repacking the UPS .....	7
<b>3.0 INSTALLATION</b> .....	<b>8</b>
3.1 Electrical preparations .....	8
3.2 Current Table and Suggested Cable Sizes .....	8
3.3 Neutral Connection .....	9
3.4 External Protection and Isolating Devices .....	9
3.5 Installation of Differential Protection Devices .....	10
3.6 External Electrical Connections .....	10
3.7 Connecting Mains and Load .....	11
3.8 Terminal Blocks for UPS .....	12
3.9 Connecting Power Cables .....	12
3.10 External Tower Batteries .....	13
3.11 Connecting an External Battery Extension .....	13
3.12 Battery Precautions .....	14
3.13 Configuration Program .....	14
3.14 Liebert GXT3-10000T230 Configuration Program Features .....	14
3.15 What You Will Need .....	14

---

<b>4.0</b>	<b>OPERATION</b>	<b>15</b>
4.1	Normal Operating	15
4.1.1	Block diagram	15
4.2	Control Panel	16
4.2.1	Controls and Messages	16
4.2.2	Warning Indicators	19
4.2.3	Fault Indicators	20
4.3	Startup Preparations	20
4.4	UPS Startup Procedure - Single Block	21
4.5	UPS Shutdown Procedure—All Ratings	21
4.6	Maintenance Bypass Procedure	21
4.7	Return from Maintenance Bypass Procedure	22
4.8	Functional Test	22
4.9	Remote Emergency Power Off	22
4.10	Self-Tests	23
4.10.1	Lamp Test	23
4.10.2	Battery Test	23
<b>5.0</b>	<b>MAINTENANCE</b>	<b>24</b>
5.1	Testing, Replacing and Disposing of Batteries	24
5.2	Easy Battery Replacement	24
5.3	Storage	25
5.4	Cleaning	25
<b>6.0</b>	<b>COMMUNICATION</b>	<b>26</b>
6.1	Communication Interface Port	26
6.2	Terminal Block	26
6.2.1	Any Mode Shutdown	26
6.2.2	Battery Mode Shutdown	27
6.2.3	On Battery	27
6.2.4	Low Battery	27
6.3	UPS IntelliSlot Communication Cards	27
6.3.1	Liebert MultiLink	28
6.4	Remote Emergency Power Off	28
<b>7.0</b>	<b>TROUBLESHOOTING</b>	<b>29</b>
<b>8.0</b>	<b>SPECIFICATIONS</b>	<b>30</b>

---

---

## FIGURES

Figure 1	Liebert GXT3-10000T230 control panel . . . . .	4
Figure 2	Liebert GXT3-10000T230 front and rear views . . . . .	5
Figure 3	Unpacking . . . . .	6
Figure 4	Standard configuration - differential breaker . . . . .	10
Figure 5	Side view . . . . .	10
Figure 6	Input and output connections with single source, single-phase input supply. . . . .	11
Figure 7	Input and output connections with dual source, single-phase input supplies. . . . .	11
Figure 8	Input and output connections with single source, three-phase input supply . . . . .	11
Figure 9	Input and output connections with dual source, three-phase UPS, single-phase bypass input supplies . . . . .	12
Figure 10	Hardwire terminals. . . . .	12
Figure 11	Liebert GXT3 10000T230 with External Battery Cabinet . . . . .	13
Figure 12	Overview of UPS tower. . . . .	15
Figure 13	Control panel. . . . .	16
Figure 14	System block, menu structure . . . . .	17
Figure 15	REPO connections. . . . .	23
Figure 16	Removing front panel and unlocking battery trays . . . . .	24
Figure 17	Disconnecting battery tray and battery packs . . . . .	25
Figure 18	Terminal block pin layout. . . . .	26
Figure 19	REPO switch connection diagram . . . . .	28

## TABLES

Table 1	Overview of UPS devices and batteries . . . . .	4
Table 2	Connection data . . . . .	8
Table 3	External protection device data . . . . .	9
Table 4	Lighted LEDs . . . . .	16
Table 5	Displayed text—system block and main menu . . . . .	18
Table 6	Warning indicators . . . . .	19
Table 7	Display faults . . . . .	20
Table 8	Battery test report messages . . . . .	23
Table 9	Troubleshooting - errors and corrective action . . . . .	29
Table 10	UPS specifications. . . . .	30
Table 11	Environmental data . . . . .	32
Table 12	Agency/safety compliance . . . . .	32
Table 13	Operating temperature parameters. . . . .	32
Table 14	Typical battery run times, minutes at 25°C (77°F), 100% resistive load. . . . .	32

---

---

## IMPORTANT SAFETY INSTRUCTIONS

---

### SAVE THESE INSTRUCTIONS



#### WARNING

Opening or removing the cover may expose you to lethal voltages within this unit even when it is apparently not operating and the input wiring is disconnected from the electrical source. Observe all cautions and warnings in this manual. Failure to do so may result in serious injury or death. Refer all UPS and battery service to qualified service personnel. Do not attempt to service this product yourself. Never work alone.

This manual contains important safety instructions that must be followed when installing, operating and maintaining the Liebert GXT3-10000T230 uninterruptible power system (UPS).

Read all safety, installation and operating instructions before installing or operating the UPS. Adhere to all warnings on the unit and in this manual. Follow all operating and user instructions.

The Liebert GXT3-10000T230 is not intended for use with life support or other designated critical devices. The UPS is designed for data processing equipment. If uncertain the intended use for this UPS, consult your dealer or Liebert representative.

This device serves as an uninterruptible power supply for connected loads. Maximum load must not exceed that shown on the UPS rating label. The device is in compliance with all relevant safety regulations concerning information technology equipment, including electronic machines for use in an office environment.

Depending on the type and rating of UPS device, certain configurations of battery extensions may be connected. These battery extensions may be connected only to the compatible basic UPS unit.



#### WARNING

Liebert considers the safety of personnel to be of paramount importance. For this reason it is essential that procedures relating to safety be studied before commencing work and properly adhered to thereafter.

The user or operator may intervene in the operation of the UPS provided that the instructions laid out in **Notes Regarding the EU Declaration of Conformity on page 3** are strictly adhered to.

The installation of the UPS, described in **Installation on page 8**, may only be carried out by qualified technical personnel.

Even when all switches and interrupters are open, hazardous voltages are present within the UPS; any operation that requires protective panels to be opened or removed may be carried out by Liebert authorized technical personnel only.



## CAUTION

Carefully read the following safety notices. Failure to observe the instructions may endanger your life, your health, the reliability of your device and the security of your data.

- Transport the unit only in suitable packaging (protected against jolts and shocks).
- If the equipment is moved from a cold environment to the operating room, condensation may occur. Before you switch On the equipment, it must be absolutely dry. An acclimatization period of at least two hours is required.
- The equipment must be installed in accordance with the environmental conditions specified in **2.6 - Environmental Conditions** and in **Table 11 - Environmental data**.
- Even with all switches in the “OFF” position (see **Figure 13 - Control panel**) the UPS is not isolated from the mains. To isolate completely from the mains, the power cables must be disconnected.
- In case of interruption of the mains voltage, the integrated battery maintains the power supply to the user equipment.
- Lay all cables so that nobody can stand on them or trip over them. When connecting the UPS to the power supply, follow the instructions in **2.0 - Unpacking the UPS and Site Preparation**.
- Make sure that no objects (e.g., pins, necklaces, paper clips, etc.) get inside the device.
- In emergencies (e.g., damaged case, controls or power cables, penetration of liquids or foreign matter), switch Off the device and contact the appropriate customer service representative.
- Do not connect equipment that will overload the UPS (e.g., laser printers or vacuum cleaners) or demand DC-current (e.g., half-wave rectifiers).
- When cleaning the unit, follow the instructions in **5.0 - Maintenance**.
- The sum of the leakage currents (protective conductor current) of the UPS and the connected devices exceeds 3.5 mA for all ratings of the UPS. Earth connection is essential before connecting supply.
- Data transmission lines should not be connected or disconnected during a thunderstorm.
- Remote Emergency Power Off (REPO) input is located on the rear of the unit (see **3.8 - Terminal Blocks for UPS**). When this connection is open, the logic circuit will immediately shut down the UPS output.
- An Emergency Switching Device (E.S.D.) must be fitted downstream of the UPS for the wiring installation safety to comply with the European Harmonized Document HD384-4-46 S1.
- Maintenance bypass switch is for the use of service personnel only. It is located under the rear cover. Open the safety cover to operate the maintenance bypass switch.
- The Tower UPS may be connected either to 3-phase mains or single-phase mains. Therefore the right input terminals have to be connected (see **3.7 - Connecting Mains and Load**). The UPS autosensing mode ensures that it adapts to the connected mains supply.
- This equipment complies with IEC 61000-3-12 provided that the short-circuit ratio  $R_{sce}$  is greater than or equal to 250 at the interface point between the user’s supply and the public system. It is the responsibility of the installer or user of the equipment to ensure, by consultation with the distribution network operator if necessary, that the equipment is connected only to a supply with a short-circuit ratio  $R_{sce}$  greater than or equal to 250.
- For three-phase equipment, the disconnect device shall disconnect simultaneously all line conductors of the AC mains supply. For equipment requiring a neutral connection to an IT power distribution system, the disconnect device shall be a four-pole device and shall disconnect all line conductors and the neutral conductor.



## CAUTION

Do **not** connect more than four Liebert GXT3-240TBATTCE battery extensions to the Liebert GXT3-10000T230. This also applies when the additional battery charger is connected.

The vents for air intake and outlet at the front and rear side must not be obstructed.

The sum of the leakage currents (protective conductor current) of the UPS and the connected devices exceeds 3.5 mA. Earth connection of the unit is essential before connecting supply.





## CAUTION

The supply to the load may be interrupted by opening all the switches or by turning the Maintenance Switch on the rear of the UPS to the Off position.

DO NOT USE WATER to extinguish any fires that may occur in the area where the UPS is installed.



## CAUTION

### Leakage currents

Connect the protection earth (PE) safety conductor before connecting any other cables.

### Radio Interference

**The Liebert GXT3-1000T230 is a Radio Interference Class A Product.**

The UPS device may cause radio interference. Do not place it near devices that are particularly susceptible to electromagnetic interference (e.g., transmitters, receivers, radar, metal detectors and anti-theft devices).

## NOTICE

This is a product for restricted sales distribution to informed partners. Installation restrictions or additional measures may be needed to prevent radio interference.

### Notes Regarding the EU Declaration of Conformity

The Liebert GXT3-1000T230 conforms to the following European directives:

- **2006/95/EC**—Directive of the council for adaptation of the legal regulations of the member states regarding electrical equipment for use within specific voltage limits, modified by directive 93/68/EEC.
- **89/336/EEC**—Directive of the council for adaptation of the legal regulations of the member states regarding electromagnetic compatibility, modified by directive 2004/108/EC.

Conformity is established through compliance with the following standards:

- EN 62040-1-1
- EN 62040-2
- EN61000-3-12
- EN61000-3-11

Additional information regarding adherence to these directives is included in the appendices NSR and EMC of the EU Declaration of Conformity.

If required, the EU Declaration of Conformity may be requested from Liebert.

**NOTICE TO EUROPEAN UNION CUSTOMERS: DISPOSAL OF OLD APPLIANCES**—This product has been supplied from an environmentally aware manufacturer that complies with the Waste Electrical and Electronic Equipment (WEEE) Directive 2002/96/CE.

The “crossed-out wheelie bin” symbol at right is placed on this product to encourage recycling wherever possible. Please be environmentally responsible and recycle this product through your recycling facility at its end of life. Do not dispose of this product as unsorted municipal waste. Follow local municipal waste ordinances for proper disposal provisions to reduce the environmental impact of waste electrical and electronic equipment (WEEE).

For information regarding the scrapping of this equipment, go to

<http://www.eu.emersonnetworkpower.com>

Click on *Products* or *Contacts* and follow the links to obtain assistance.

Information is also available by telephoning our worldwide technical support:

- Toll free: 00 80011554499
- Toll number (in Italy): +39 0298250222

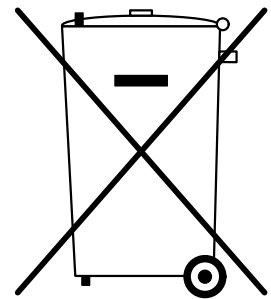

## 1.0 INTRODUCTION AND SYSTEM DESCRIPTION

Congratulations on your purchase of the Liebert GXT3-10000T230. This system provides conditioned power to microcomputers and other sensitive electronic equipment.

Upon generation, AC power is clean and stable. However, during transmission and distribution it is subject to voltage sags, spikes and complete power failure that may interrupt computer operations, cause data loss and damage equipment. The Liebert GXT3-10000T230 protects equipment from these disturbances.

The Liebert GXT3-10000T230 is a compact, on-line UPS. An on-line UPS continuously conditions and regulates its output voltage whether utility power is present or not. It supplies connected equipment with clean sinewave power. Sensitive electronic equipment operates best from sinewave power.

For ease of use, the Liebert GXT3-10000T230 features an LCD display for comprehensive user indications and programmable controls. It also provides self-diagnostic tests.

The Liebert GXT3-10000T230 has an interface port for communication between the UPS and a network server or other computer system. This port provides detailed operating information including voltages, currents and alarm status to the host system when used in conjunction with Liebert's MultiLink™ software.



### CAUTION

This UPS may only be operated by qualified personnel.

Figure 1 Liebert GXT3-10000T230 control panel



### 1.1 Device Overview

The Liebert GXT3-10000T230 is available at various nominal power ratings.

The following table provides an overview of the various versions of the device:

Table 1 Overview of UPS devices and batteries

Type	Model #	Nominal power
UPS with integrated battery	Liebert GXT3-10000T230	10000 VA/ 9000W
Battery cabinet	Liebert GXT3-240TBATTCE	240VDC

Figure 2 Liebert GXT3-10000T230 front and rear views

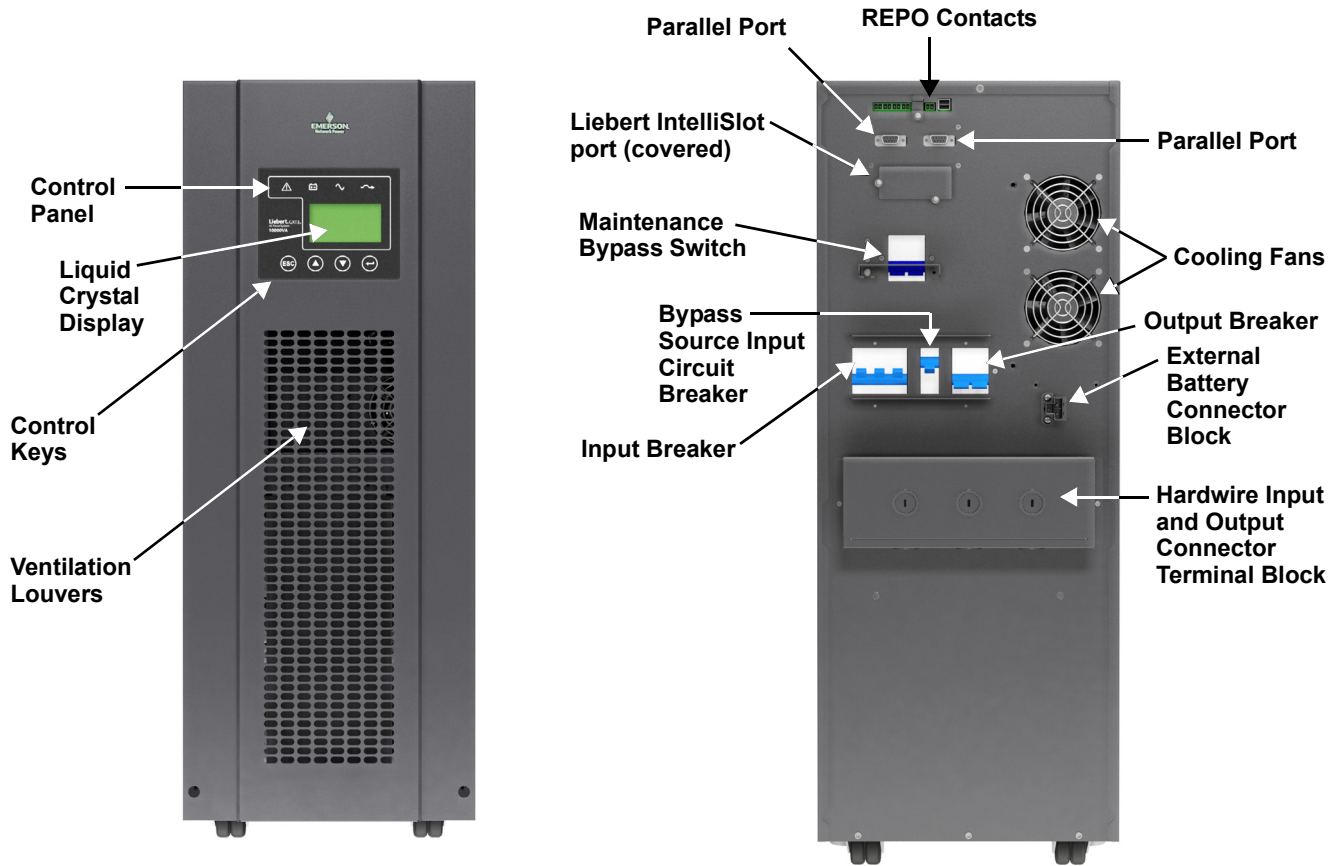

## 1.2 Options

### 1.2.1 External Battery Cabinets

Optional external battery cabinets are available to extend UPS autonomy in the event of mains interruption. The cabinets have the same dimensions, color scheme and design as the Liebert GXT3-10000T230.

For technical data about external battery cabinets see **Table 10 - UPS specifications**.

For connection notices see **Table 2 - Connection data**.

### 1.2.2 Optional Interfaces

Refer to **6.0 - Communication** for details.

## 2.0 UNPACKING THE UPS AND SITE PREPARATION

### 2.1 Inspection

Upon receiving your Liebert GXT3-10000T230, examine the packaging for any signs of mishandling or damage. While removing the packaging materials, inspect the UPS for damage. If any damage is noted, notify your local Liebert representative and carrier. Any damage or missing parts must be reported to the supplier within eight days of delivery.

### 2.2 Required Setup Equipment

The following tools are required to set up your UPS:

- pallet jack
- utility knife or scissors
- star head screwdriver

### 2.3 Unpacking

Take care when removing the packaging to avoid damaging the UPS. Do not dispose of the packing material. The original packaging material should be used if the UPS needs to be repackaged, such as for shipping. Check all packaging to ensure that no items are accidentally discarded. Remove the packaging in the sequence shown below.

Figure 3 Unpacking

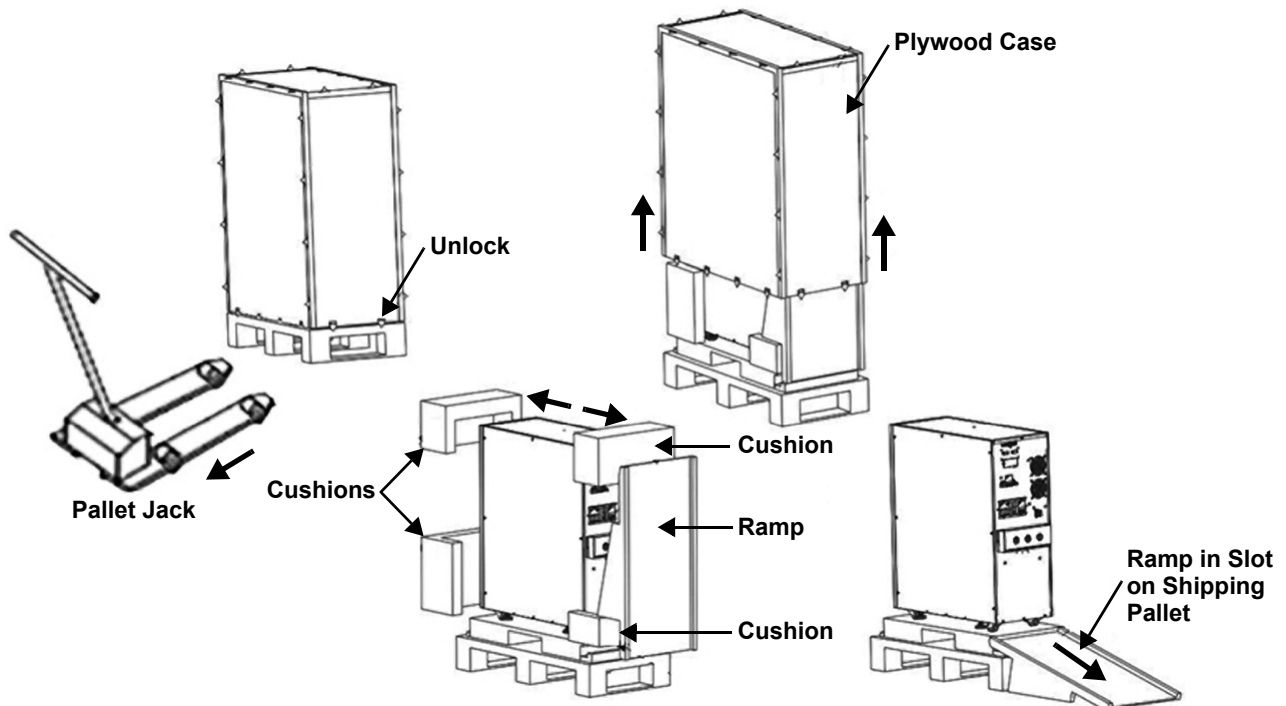

### 2.4 Storage

If the UPS will not be installed immediately, store the unit indoors in a clean and dry area. Protect all the equipment, including its batteries, from extreme temperature, high humidity, spills and other damaging conditions. Refer to **Table 11** for permissible environmental conditions for storage.

### 2.5 Handling

The equipment must be kept upright at all times and handled with care. It may be damaged if dropped or subjected to severe impact.

## 2.6 Environmental Conditions

The Liebert GXT3-10000T230 must be installed vertically, on a level and even surface and in an area protected from extreme temperatures, water, humidity and the presence of conductive powder or dust (see **Table 11**). Do not stack units; do not place any objects on top of a unit.

## 2.7 Access required

The area must have sufficient space for installation procedures and for routine maintenance. Access doors must be sufficiently large to permit passage of the UPS.

## 2.8 Floor/Rack Loading

Ensure that the floor where the UPS/batteries will be installed will support the unit's weight (see **Table 10** for the unit's weight).

## 2.9 Inventory List

The Liebert GXT3-10000T230 comes with:

- CD containing:
  - Liebert MultiLink<sup>®</sup> Shutdown Software
  - Configuration Software
  - User Manual
- USB cable
- Terminal block communication terminals
- Floor mount brackets
- Input power configuration jumpers
- Paralleling cable

## 2.10 Clearance

The UPS is fitted with wheels for ease of movement over short distances. Leave 300mm (12in.) around the sides and rear of the unit to allow a flow of air and to provide access for any routine maintenance that may involve removal of the panels.

## 2.11 Repacking the UPS

To repack the UPS, proceed as follows:

1. Do not pack the equipment until at least six hours have elapsed since the last recharge.
2. Make sure to re-use the original packing material to ship the UPS.

## 3.0 INSTALLATION

### 3.1 Electrical preparations

Before you begin installation, the input source must be isolated and secured to prevent reconnection during installation. The input circuit breaker on the rear of the UPS must be in the Off position.



### WARNING

Installation may be carried out only by qualified technicians, conforming to applicable safety standards.

Electric shock hazard: Even when the unit is disconnected from the mains, hazardous voltage may still be supplied by the battery. Both poles should be disconnected before carrying out maintenance work inside the UPS.

For electrical installation, the nominal current rating of the source must be observed. The UPS is not suitable for connection to 16A subdistribution systems.

### 3.2 Current Table and Suggested Cable Sizes

The following table indicates the currents and recommended sizes of the connecting cables in accordance with regulations IEC-287 and DIN VDE 0298

1. PVC-insulated copper cables (@ 70°C) (158°F).
2. Air temperature surrounding the conduits should not be greater than 30°C (86°F).



#### NOTE

*Should there be any variation in the conditions, it will be necessary to verify whether the cable dimensions satisfy the requirements of IEC-287 and DIN VDE 0298. In cases where the cables are so long that they cause a drop in voltage of >3%, a larger size must be used.*

**Table 2 Connection data**

Description	Unit	UPS Power Rating	
	kVA	10 - 1/1	10 - 3/1
Connector size	mm <sup>2</sup>	10	10
Max input current	Arms	53	53
Input cable size (and neutral)	mm <sup>2</sup>	10	10
Max output current	Arms	51	51
Output cable size (and neutral)	mm <sup>2</sup>	10	10
Earth cable size	mm <sup>2</sup>	10	10

When the UPS is in Bypass mode, the entire output current of the UPS is passed through the phase L1 and Neutral cables. To simplify connection data, no distinction has been made between phase L1 and phases L2 and L3. The cable sizes are defined for the maximum current carried by the output cables.



### WARNING

Particularly sensitive equipment may be susceptible to interference. To prevent this, Liebert suggests:

Mains input, output and external battery cables to the UPS in earthed, metal conduits, or

Use shielded cables

Routing of cables (e.g. power supplies, communication or data lines) to other equipment, should be kept separate from that of UPS cables.

### 3.3 Neutral Connection

The installation of the UPS does not affect the existing neutral system.

The neutral system may be affected if the UPS is operating with the neutral switched upstream.

### 3.4 External Protection and Isolating Devices

External devices for the protection of cables and for isolating the UPS external to the UPS must be installed upstream of the equipment. Select and configure the isolating device according to **Table 3**.

- Such devices must be either curve C automatic circuit breakers or type GL/GG fuses.
- Disconnecting devices must be provided in building installations and other locations.



## WARNING

The following label must be displayed on all switching devices installed in the same electrical system as the UPS, even when they are located at a distance from the area.

*ENSURE THAT THE UNINTERRUPTIBLE POWER SYSTEM IS ISOLATED BEFORE WORKING ON THIS CIRCUIT.*

**Table 3 External protection device data**

Protection Description		Tower Power Rating (Phases In/Out)	
		10 - (1/1)	10 - (3/1)
Input	Fuse	120 Amps	40 Amps
	Breaker	96 Amps	32 Amps
Output	Fuse	90 Amps	90 Amps
	Breaker	63 Amps	63 Amps

This table indicates the protection devices (circuit breakers and fuses) that must be installed for the protection of both the cables and the equipment.



## NOTE

*If an external battery cabinet is present it should be located next to the UPS unit.*

*When such an option is supplied by Liebert it comes complete with protection devices and correctly-sized cables.*

*When batteries are sourced from other suppliers, you should contact Customer Support Technical Service for correct sizing of protection devices and interconnection cables.*

### 3.5 Installation of Differential Protection Devices

To avoid spurious operation, differential protection devices must be:

- rated at differential current NOT LESS THAN 100mA
- a SELECTIVE type (delayed intervention)
- Type A

Figure 4 Standard configuration - differential breaker

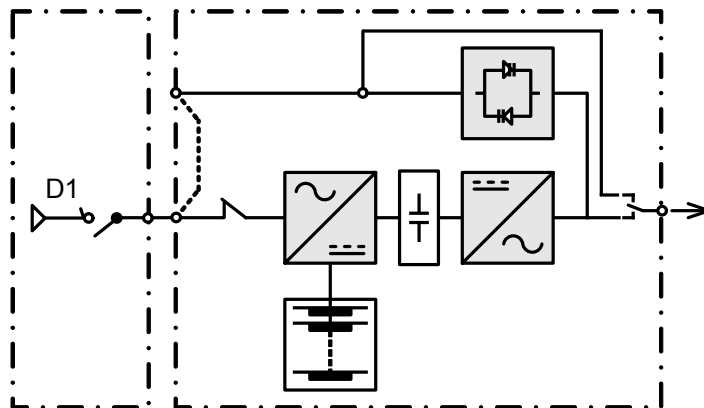

### 3.6 External Electrical Connections

Remove the protective panel on the rear of the UPS to access the external electrical connections (see figure below). Once the cables have been connected they must be passed through the cable clamps that will hold them in position. Connect the earth cable first.



#### WARNING

Ensure that the UPS is isolated before removing panels.

Figure 5 Side view

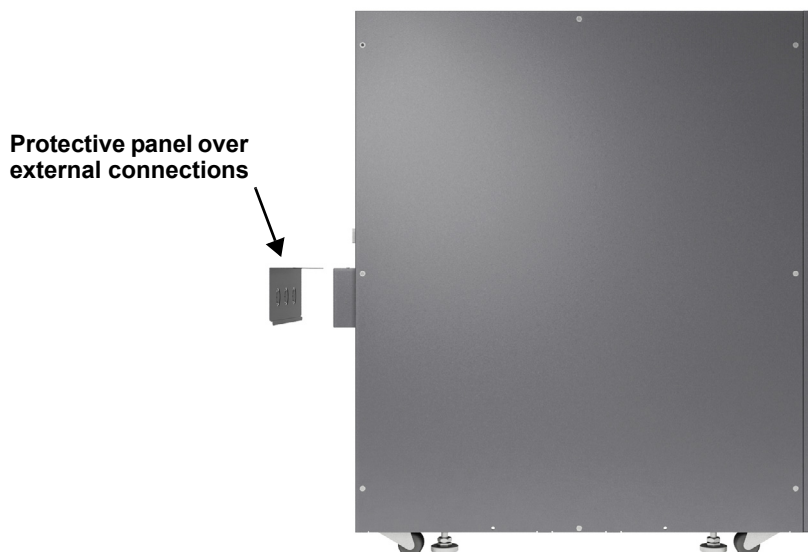

#### NOTE

Once installation has been completed, fix the UPS in position by screwing the stabilizing plates underneath the unit firmly to the floor.



### 3.7 Connecting Mains and Load

When connect the mains supply to the UPS refer to **Figures 6** through **8**. Choose the connection method according to the input supply characteristics. Connections must meet these requirements:

- The installer must provide circuit breaker protection according to local codes. The mains disconnect should be within sight of the UPS or have an appropriate lock-out. Maintain service space around the UPS or use flexible conduit.
- The installer must provide output distribution panels, circuit breaker protection, or emergency disconnect switches according to local codes. Output circuits must not share a common conduit with input circuits or any other wiring.
- The utility may be derived from a single-phase or three-phase source.

**Figure 6** Input and output connections with single source, single-phase input supply

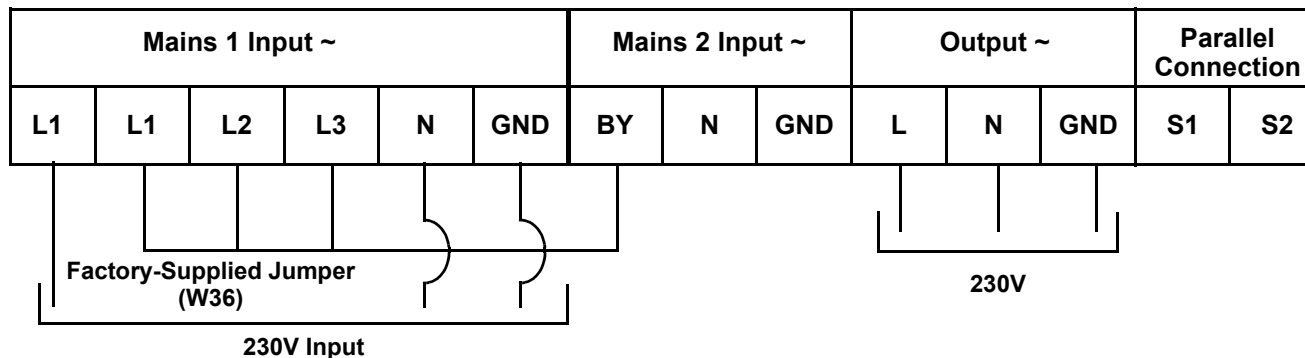

**Figure 7** Input and output connections with dual source, single-phase input supplies

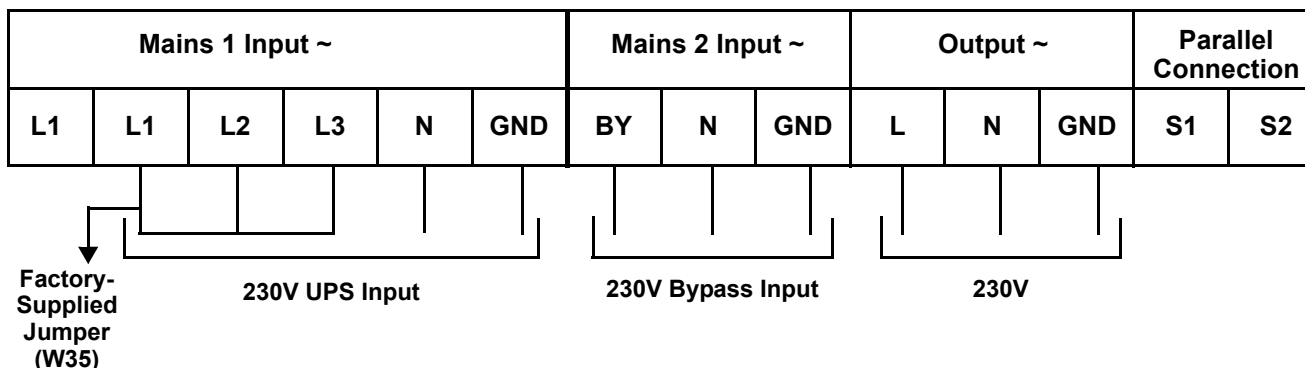

**Figure 8** Input and output connections with single source, three-phase input supply

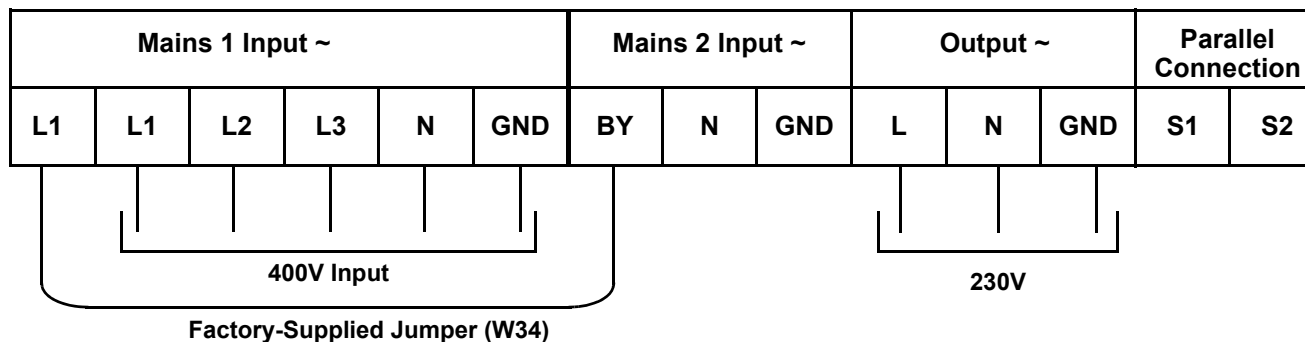

**Figure 9** Input and output connections with dual source, three-phase UPS, single-phase bypass input supplies

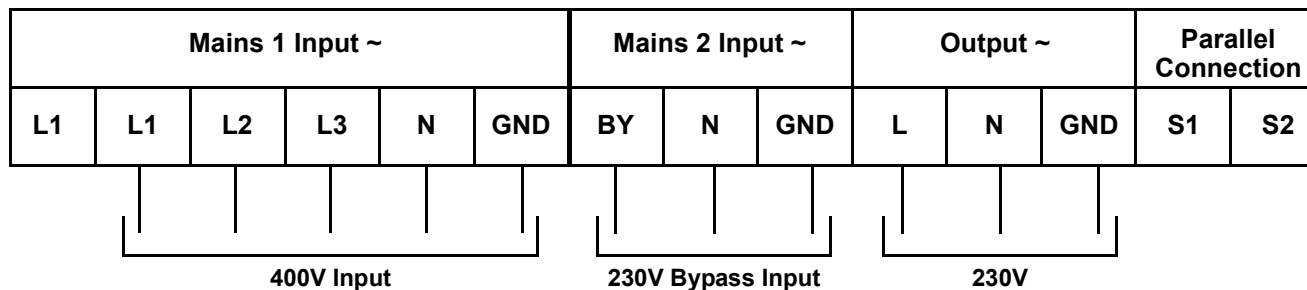

**NOTE**

*During connection of a 3-phase input system, care must be taken to ensure each phase is connected to the corresponding phase on the input terminal block. Failure to make connections correctly could damage the unit.*

*Output cable cannot exceed 10m (39ft).*

**3.8 Terminal Blocks for UPS**

The three-position maintenance switch includes the output breaker.

**Figure 10** Hardwire terminals

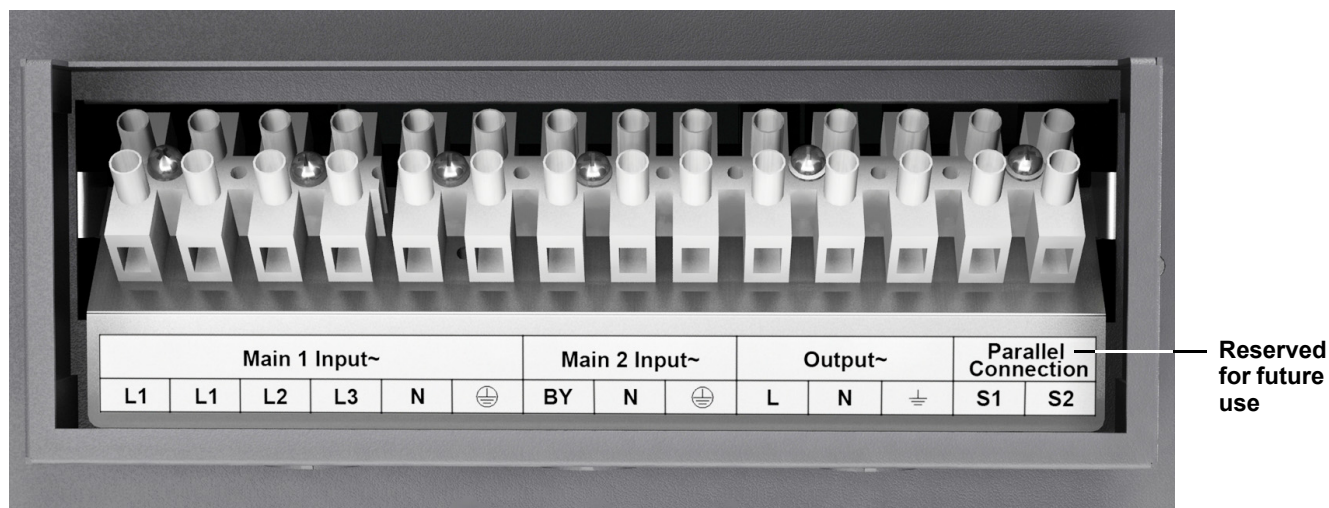

**3.9 Connecting Power Cables**

1. Open the UPS input breaker.
2. Open the UPS output breaker.
3. Remove the terminal area safety cover from the rear UPS panel.
4. Connect loads to the output terminals.
  - Connect the mains to the corresponding input terminals (see Figure 3-5).
  - If the reserve input is to be supplied separately, connect reserve line to the Mains 2 terminals.
  - If the UPS is supplied by a common mains, connect the supplied jumper in the accessory kit marked "W34" between the first L1 from the left (Mains 1) and BY (Mains 2) as shown in **Figure 8**.

### 3.10 External Tower Batteries

One or more battery cabinets may be connected to the Liebert GXT3-10000T230. A cable to connect the battery cabinet and the Liebert GXT3-10000T230 is supplied with each battery cabinet. Plug this cable into the battery cabinet and UPS battery sockets—slotted fittings on each and ensure that the connection is properly made. If your UPS has an integrated battery, a compensating current may occur during connection.

Figure 11 Liebert GXT3 10000T230 with External Battery Cabinet



### 3.11 Connecting an External Battery Extension



#### NOTE

*External battery extensions can be replaced during normal operation of the UPS (hot swappable). However, the batteries must NOT be changed when the UPS is in the status “Battery Mode operation”.*

The unit checks the battery voltage (a beep is heard) once more and stays in bypass till a constant battery voltage is present.



#### CAUTION

Battery maintenance must be carried out by authorized personnel observing the necessary precautions.

### 3.12 Battery Precautions

- The batteries installed in the UPS and within the battery extensions may contain electrolyte. Under normal conditions, the containers are dry. A damaged battery may leak electrolyte, which can cause skin and eye irritation. Should this happen, wash the affected area with plenty of water and seek immediate medical attention.
- Do not open or damage batteries. The released electrolyte is toxic.
- Voltage is always present on the battery contacts.
- Even when discharged, a battery has the capacity a high short circuit current which, in addition to causing damage to the battery itself and associated cables, may expose the operator to the risk of burns. The following precautions should be observed when working with batteries:
- Remove watches, rings and other metal objects.
- Use tools with insulated handles.
- The voltage of a single cell of a battery is not dangerous. However a number of cells or battery blocks, connected in series, can produce hazardous voltages.
- The battery cabinet must not be kept in storage or not used for periods exceeding six months (at 20°C) without being recharged (having been charged to 100% at the beginning of any such period). If this period is exceeded, it is essential that the batteries be recharged (which requires the UPS to be switched On). If these conditions are not met, the battery performance can no longer be guaranteed. We recommend recharging the batteries at least once every four months.
- Since new batteries often do not provide full capacity after the initial charge, it may be necessary to carry out a number of discharge/recharge cycles before optimum performance is reached.
- When replacing batteries, replace with the same type and number of batteries and battery packs.
- In order to protect the environment, batteries must be disposed of in accordance with local laws concerning the safe disposal of toxic and harmful waste.
- Do not dispose of batteries in a fire. The batteries may explode.

### 3.13 Configuration Program

The final step of installation may require custom configuration of your UPS using the enclosed configuration program. Some configuration settings may be changed only while the UPS is Off. These should be set before the UPS is put into full-time use.

For most users operating with 230VAC, the factory default settings will be adequate.

### 3.14 Liebert GXT3-10000T230 Configuration Program Features

- Select one of the three L-N output voltages to match local voltage.
- Enable/disable auto-restart.
- Select frequency converter operation with a fixed output frequency of 50 or 60 Hz.
- Set the 'Low battery warning' alarm time from 2 to 30 minutes.
- Enable/disable auto-battery test.
- Set auto-battery test frequency to 7, 14, 21 or 28 days.
- Specify the number of external battery cabinets connected to the UPS to adjust the remaining run time calculations reported by the system software.

### 3.15 What You Will Need

In addition to the Liebert GXT3-10000T230, you will need the configuration program CD and USB cable included in the UPS accessory pack. You must be running Microsoft® Windows® XP or later on your computer.

## 4.0 OPERATION

### 4.1 Normal Operating

#### 4.1.1 Block diagram

The Liebert GXT3-10000T230 consists of several main components:

- 2 mains supplies (mains and reserve)
- Rectifier/booster, inverter and charger
- Internal electronic bypass
- 2 input breakers
- Maintenance bypass breaker
- TVSS filter
- Integrated battery (expandable)

Figure 12 Overview of UPS tower

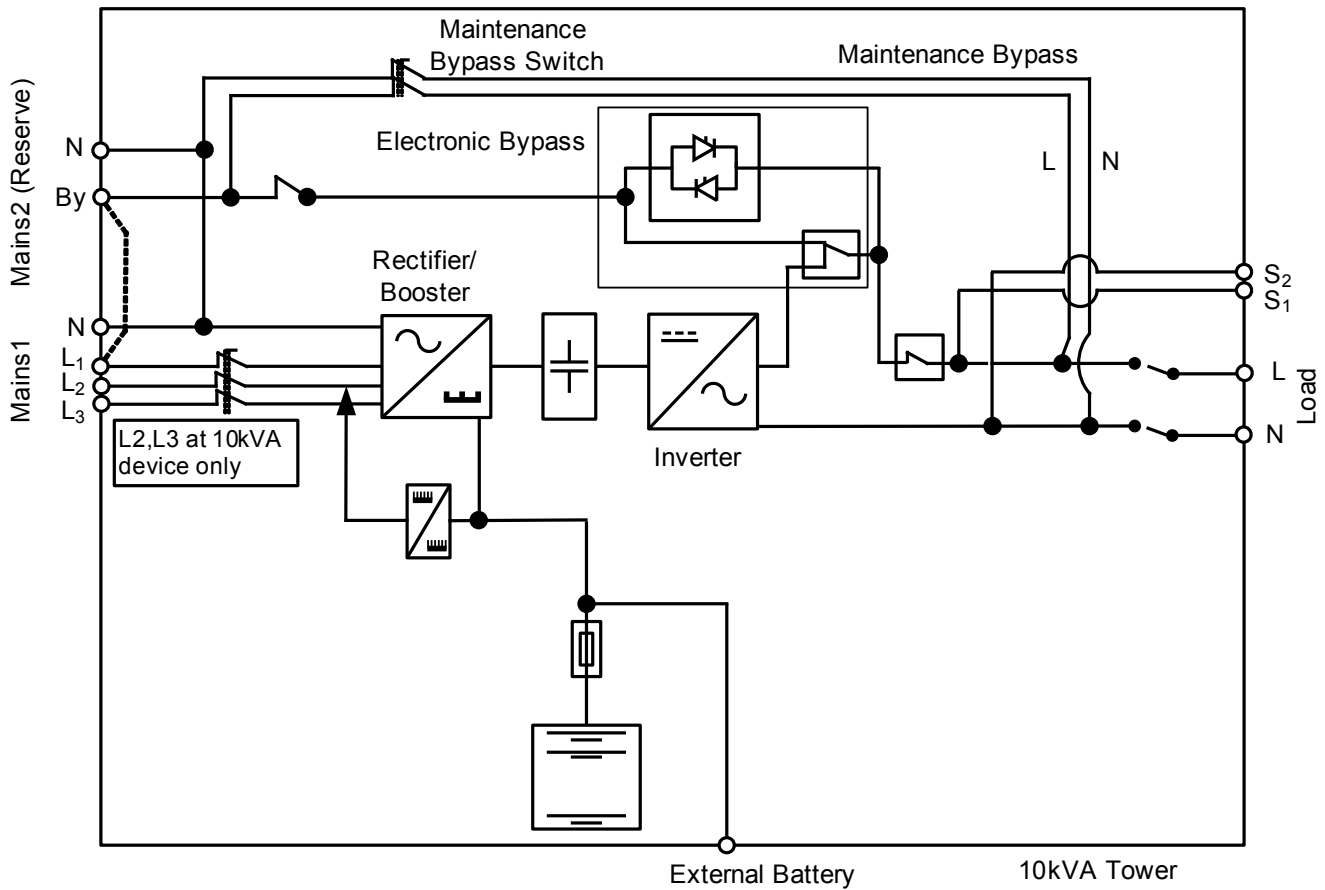

## 4.2 Control Panel

The display text is shown as a 10kVA UPS.

Figure 13 Control panel

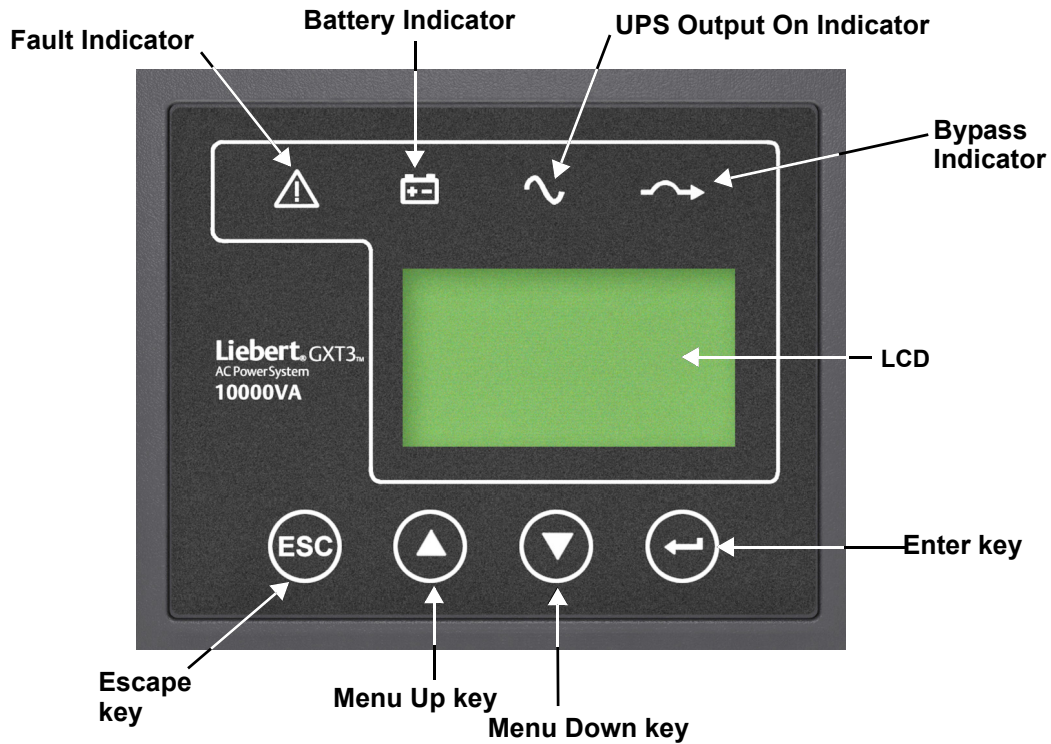

### 4.2.1 Controls and Messages

Table 4 Lighted LEDs

LED Indicator	LED Color	Description
UPS ON	Green	UPS is online and operating normally
BYPASS	Amber	Load is supplied by the mains via automatic bypass
BATTERY	Amber	Load is supplied by the battery
FAULT	Red	An error has occurred within the UPS

**Flashing LED**—When the BYPASS LED is flashing, the mains is out of tolerance



## CAUTION

Do not switch Off the UPS or switch from online to bypass while in this status, otherwise load will no longer be supported.

The following displays the menu structure that can be accessed through the control panel. Press the **Menu Up** or **Menu Down** buttons to scroll through each menu. Press **Enter** to choose an entry.

Figure 14 System block, menu structure

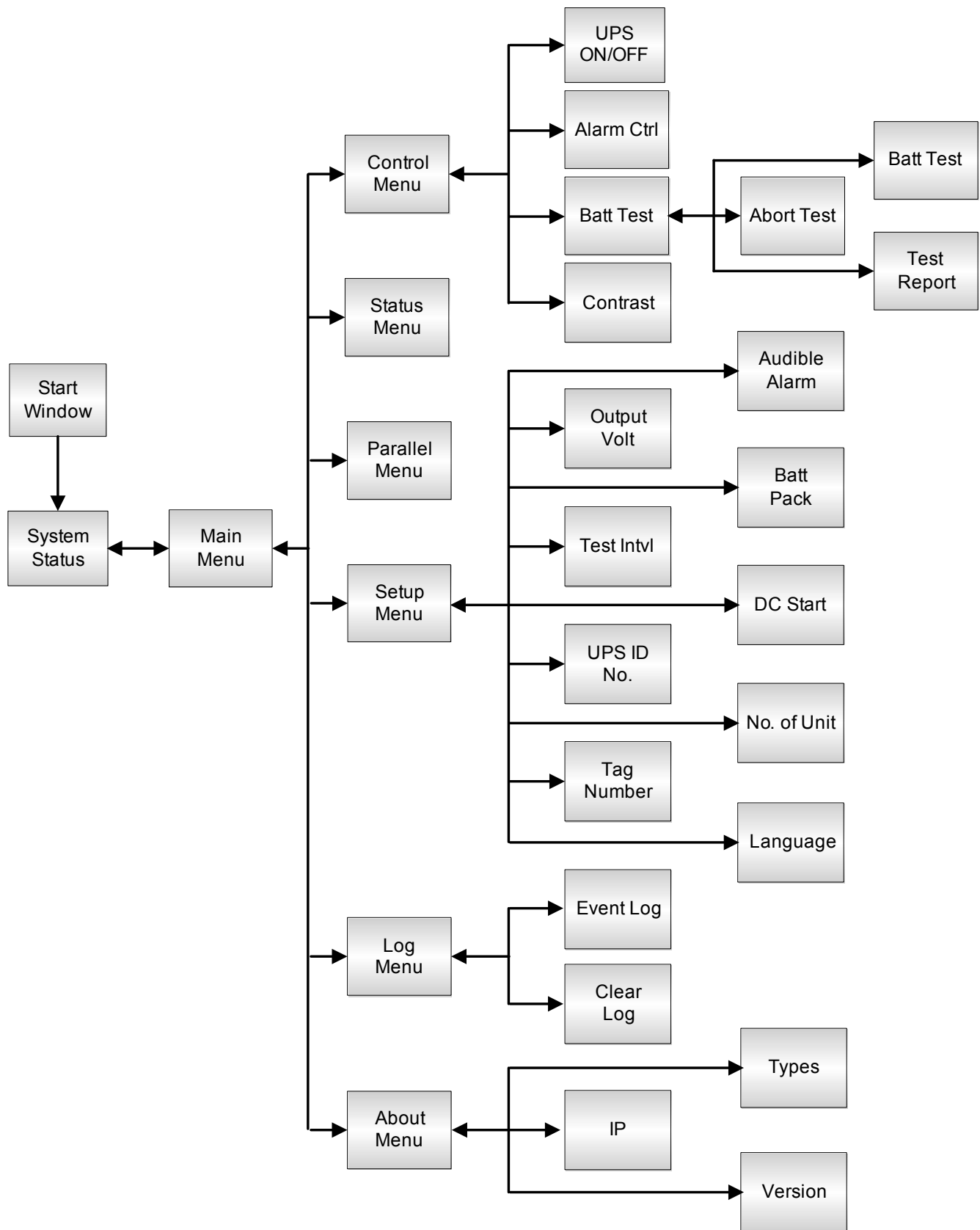

**Table 5 Displayed text—system block and main menu**

Item# and Name		Description		
START WINDOW		UPS 10kVA Self Testing		
MAIN MENU		Control		
		Status		
		Parallel		
		Setup		
		Log		
		About		
CONTROL MENU		UPS ON/OFF	Turn On	
			Shut Down	
			Turn Off	
			To Bypass	
		Alarm Ctrl	Alarm On	
			Alarm Off	
		Batt Test	Batt Test	
			Abort Test	
			Test Report	
		Contrast	Darker	
		Lighter		
STATUS MENU	Measure Value	Unit		
	Output Volt	V		
	Output Freq	0.1Hz		
	Output Curr	A		
	Output Watt	W		
	Output VA	VA		
	Load Level	%		
	Input Volt	V		
	L2 Input Volt	V		
	L3 Input Volt	V		
	Input Freq	0.1Hz		
	Batt Volt	V		
	Batt Cap	%		
	Backup Time	Min,sec		
	Elapsed Time	day:hr:min;sec		
	Tag Number			
	PARALLEL MENU	SysOutI	A	
SysOutV		V		
SysOutF		Hz		
SysOutW		W		
SysOutVA		VA		
SysLoadPer		%		



**Table 5** Displayed text—system block and main menu

Item# and Name		Description		
SETUP MENU	Setting item			Setting(level 1)
		Audible Alarm		Disable/Enable
		Output Volt		220V/230V/240V
		Batt Pack		1-4
		Test intvl		
		DC Start		Disable/Enable
		UPS ID No.		1-3
		No. of Unit		1-3
		Tag Number		00000-99999
		Language		English/French/Spanish/ German/Italian/Russian
LOGGING MENU		Event log		
		Clear log		
	* Max 4 fault event record			
FIRMWARE VERSION	Types	Liebert Corporation GXT 10KVA		Liebert GXT3 10kVA
	IP	Web:www.liebert.com		www.liebert.com
	Version	Display Firmware version		MCU Version:V*** DSP Version: V***

#### 4.2.2 Warning Indicators

If a warning indicator appears, the UPS continues to operate. The warning message alternates with UPS mode once a second (see **Table 6**)

The warning indicators are described below:

**Table 6** Warning indicators

Warning	Cause	Corrective Steps
1	No Redundancy	
2	InvASynFault	
3	ParaCommuErr	
4	CurShareFault	
5	ParaFreqErr	
6	Byp Reminder	
7	L2 or L# Fail	Check L2, L3 input fuse
8	UtilFail	N/A
9	BattUnderVolt	N/A

### 4.2.3 Fault Indicators

If a fault occurs, the UPS automatically switches to BYPASS mode. Only in the case of a battery disconnection fault will the original operating mode be maintained. The fault message alternates with UPS mode once a second, the red fault LED on the control panel lights up and the alarm sounds continuously. If a fault occurs, proceed as follows:

**Alarm operation**—The alarm can be switched On or Off.

**Clear Fault**—Present fault condition can be reset if fault condition is cleared, either automatically or by the user.

**Fault information**—A maximum of four faults can be displayed in this window. All fault displays include:

- The nature of the event
- The time of the event

The fault indicators are:

**Table 7 Display faults**

Fault	Cause	Corrective Steps
1	Comm Shutdown	Call customer service
2	Inv Fault	Call customer service
3	Over Temp	Reduce load
4	Batt Test Fail	Call customer service
5	PFC Failure	Call customer service
6	Over load	Reduce load
7	DCDC Failure	Call customer service
8	DC BUS Fault	Call customer service
9	Charger Fault	Call customer service
10	REPO	N/A
11	Byp Feedback	Call customer service
12	Startup No Batt	Check battery
13	Mnt Byo Swt On	Call customer service
14	Fan Fault	Call customer service
15	Batt Disconnect	Check battery connector
16	ParaCableFault	Call customer service
17	ParaAddOverlap	Call customer service
18	Turn On Fail	Call customer service

### 4.3 Startup Preparations

Before switching On the UPS and supplying the load, ensure the following:

- The ventilation grilles are unobstructed
- The earth connection is in place
- The 'consumer' breakers are in the Off (0) position
- The UPS rear panel breakers are in the Off (0) position



#### WARNING

As soon as the UPS is connected to input power, the output sockets are live, even if the UPS is not yet switched On.

Once recharging has been completed, the UPS is ready for use.



#### WARNING

Do not connect any devices that may overload the UPS or draw DC current.



#### NOTE

*You may experience problems with the electrical supply if you do not follow these instructions.*

#### 4.4 UPS Startup Procedure - Single Block

1. Ensure all switches and circuit breakers upstream of the UPS are closed.
2. Ensure mains connections are secured at the UPS input. UPS requires twin supplies or one supply and one bridge. If the UPS is supplied from one mains only, mains connectors have to be fixed to the terminals section Mains 1. The jumper must be fixed as:  
**From L1 - mains 1 to BY - mains 2**
3. Switch both Input breakers (mains 1 and mains 2/reserve) to **ON (I)**. The LCD displays **Self testing, Please wait** (see 4.2.1 - Controls and Messages).
4. Press **OK** and scroll to find the Setup menu.
5. Check and adjust if necessary parameters for language, voltage and battery pack(s) (see **Table 5** for more information). The default language is English.
6. Close any external switches connecting the load (if present).
7. Press the **Menu** button, select **Control** and press **OK**.
8. Select **Turn UPS ON/OFF** and press **OK**. The LCD will display **Turn ON**.
9. Press **OK** to switch On the inverter. The LCD will display **Powering UP**.



### WARNING

If the load indication is greater than 100%, then the energy demand from the connected load exceeds the power rating of the UPS. In addition to a warning being displayed on the front panel, a beep (once a second) will sound.

#### 4.5 UPS Shutdown Procedure—All Ratings



#### NOTE

*Carrying out this procedure will interrupt the supply to load.*

1. Press the **Menu** button, select **Control** and press **OK**.
2. Select **UPS ON/OFF** and press **OK**.  
The LCD displays **To Bypass**.
3. Press **OK** to switch Off the inverter.
4. Open any external switches connecting the load (if present).
5. Switch both input switches to the **Off** Position.
6. Ensure all switches and circuit breakers upstream of the UPS are open.
7. Ensure that all LEDs on the control panel are Off.

The UPS is now shut down.

#### 4.6 Maintenance Bypass Procedure

1. Press the **Menu** button, select **Control** and press **OK**.
2. Select **UPS ON/OFF** and press **OK**.  
The LCD displays **To BYPASS**.
3. Press **OK** to switch Off the inverter and transfer to internal bypass.
4. Remove the safety cover from the Maintenance switch, and turn On the Maintenance Bypass Breaker.



#### NOTE

*At this point, the load is no longer protected against interruptions and disturbances of the mains.*

5. Switch output and input switches to the **Off** position.
6. The UPS is now switched Off, all LEDs are Off and the load is supplied directly from the mains.

## 4.7 Return from Maintenance Bypass Procedure

1. Ensure all switches and circuit breakers upstream of the UPS are closed.
2. Switch both input switches to the **On** position.
3. Wait at least 30 seconds until the output voltage has stabilized (the yellow LED is lit).
4. Switch the Maintenance switch from **BYPASS** to **UPS** and replace the cover. The load is now supplied via internal bypass.
5. Press the **Menu** button, select **Control** and press **OK**.
6. Select **UPS ON/OFF** and press **OK**.  
The LCD displays **UPS to ON**.
7. Press **OK** to switch On the inverter.

## 4.8 Functional Test



### NOTE

*Supply to the load is not guaranteed during this test. The test should not be carried out if a critical load is connected to the UPS.*

The Liebert GXT3-10000T230's controls permit testing the UPS to ensure that the load will be supplied in the event of a mains failure.

Before beginning, ensure that the batteries are fully charged.

Simulate a mains failure by interrupting the mains supply to the UPS. You can do this by switching Off the input power circuit breaker on the rear panel of the UPS. If the mains supply to the Liebert GXT3-10000T230 is protected by an external circuit breaker, opening that circuit breaker will interrupt the mains supply and simulate a power failure.

The Liebert GXT3-10000T230 is operating properly and the batteries are charged if:

- An audible signal is heard at four-second intervals
- The UPS On LED indicator turns Off

When the interval between the audible signals decreases to 10 seconds, the UPS has battery reserve energy to supply the load for a maximum of two more minutes. After two minutes, the Liebert GXT3-10000T230 will automatically shut down.

If the batteries do not supply the load during the simulation, refer to **7.0 - Troubleshooting**. To end the simulated mains failure, restore the input power supply to the UPS. The UPS is now ready for operation.



### NOTE

*The batteries must be recharged before the complete emergency supply period is again available.*

## 4.9 Remote Emergency Power Off

The UPS is equipped with an Emergency Power Off circuit. A factory-installed jumper allows the UPS to operate without an external shutoff switch.

If a Remote Emergency Power Off switch is required, a switch with normally closed contacts must be used.

Connect the switch contacts to the UPS by removing the factory-installed jumper as shown in **Figure 15**.

Figure 15 REPO connections

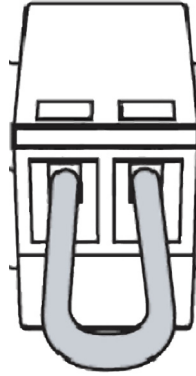

## 4.10 Self-Tests

### 4.10.1 Lamp Test



**NOTE**

*This test involves putting the Liebert GXT3-10000T230 into bypass mode. The load is not protected against any mains disturbance or interruptions while the UPS is in bypass mode.*

1. With the Liebert GXT3-10000T230 connected to the mains, press the **Menu** button, select **Control** and press **OK**.  
Select **UPS ON/OFF** and press **OK**.  
The LCD will show **To BYPASS**.
2. Press **OK** to switch the inverter to Bypass mode.  
A system confirmation beep will sound.

### 4.10.2 Battery Test



**NOTE**

*During the test a beep will sound as though the device is operating in battery mode.*

1. Press the **Menu** button.
2. Select **Control** and press **OK**.
3. Select **BATT TEST** and press **OK**.  
A system confirmation beep will sound and the load will be supplied by the battery.

If the test is successful, the BATT LED will turn off, and the UPS will return to Line mode. If the UPS circuitry detects a battery malfunction, the system will display an alarm (see 4.2.1 - **Controls and Messages**)

See **Table 8** for battery test report messages:

**Table 8 Battery test report messages**

Menu entry	Display
Battery test report	In Progress
	Test OK!
	Test fail

## 5.0 MAINTENANCE

### 5.1 Testing, Replacing and Disposing of Batteries

The UPS does not require maintenance by the user. When the batteries expire, they must be replaced by the appropriate customer service representative. For servicing, replace batteries with the same type and number of batteries or battery packs that were installed at the factory. For the battery type, see **Table 10**.

Disposal of the UPS and batteries should be carried out by a certified disposal company - observe all local regulations and laws. Exhausted accumulator batteries are classified as harmful toxic waste and as such the law demands that they be disposed of by an authorized recycling centre.

The Liebert power protection customer service centre is fully equipped to deal with such batteries, in accordance with the law and with the greatest respect for the environment.

The typical battery life cycle is three to five years, at an ambient temperature of 77°F (25°C), but is also dependent on the frequency and duration of mains failures.

The battery test (see **4.10.2 - Battery Test**) should be run periodically (every 6 to 12 months) to ascertain the general condition of the batteries and to ensure maximum run time.

### 5.2 Easy Battery Replacement

Open the front panel as shown below. Ensure that a certified service engineer is present to replace the batteries.

1. Open the battery tray DC connectors as shown
2. Remove the battery trays from the cabinet
3. Replace the old batteries with a new set. Replacement batteries must be the same type installed at the factory
4. Reconnect the battery cables

**Figure 16 Removing front panel and unlocking battery trays**

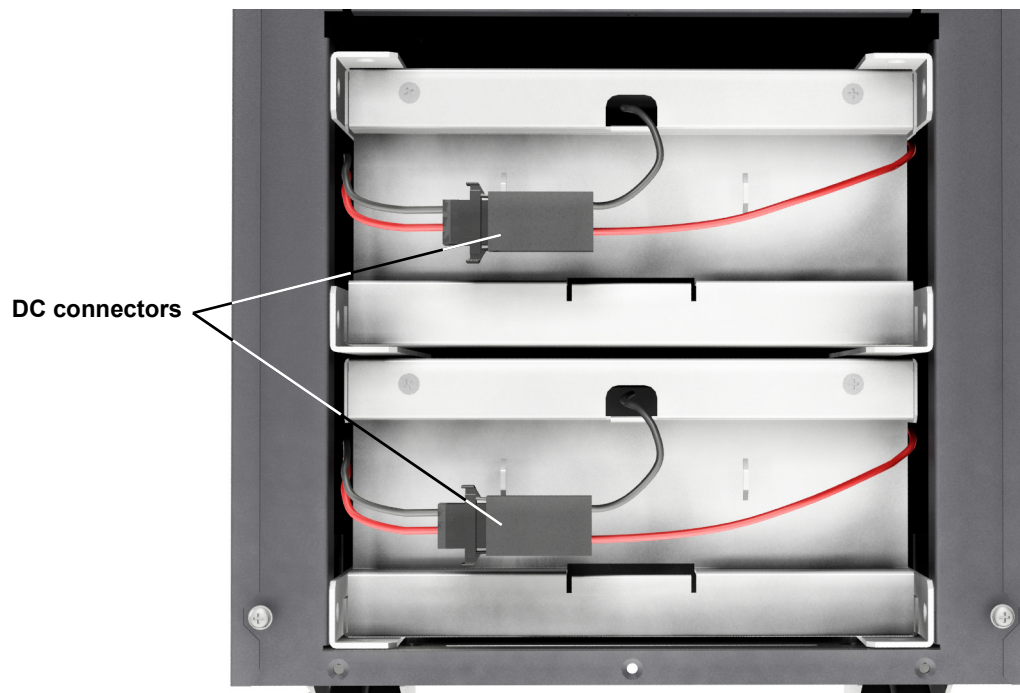

**Figure 17 Disconnecting battery tray and battery packs**

### 5.3 Storage

For extended storage at ambient temperatures cooler than 25°C (77°F), the batteries should be charged for five hours once every four months. At higher storage temperatures, Liebert recommends charging batteries for five hours every two months.

After five hours, disconnect from the mains supply or switch Off the input miniature circuit breaker of the UPS. Then remove the UPS connections in the opposite sequence to that described in **3.0 - Installation**.

Record the battery charging date in the vicinity of the UPS, for example, on its packaging.

### 5.4 Cleaning

1. Do not clean the UPS with scouring powder or solutions that may dissolve plastic.
2. Do not allow liquid to get inside the UPS.
3. Make sure that the air vents on the UPS are not obstructed. Remove dust from the air vents with a vacuum cleaner.
4. Clean the outside of the UPS by wiping the housing with a dry or slightly damp cloth.

## 6.0 COMMUNICATION

### 6.1 Communication Interface Port

The Liebert GXT3 UPS has a terminal block on the rear of the UPS unit. Several signals are provided on this port and are assigned as follows.

### 6.2 Terminal Block

The terminal block includes eight pins in four sets, as shown in **Figure 18**.

**Figure 18 Terminal block pin layout**

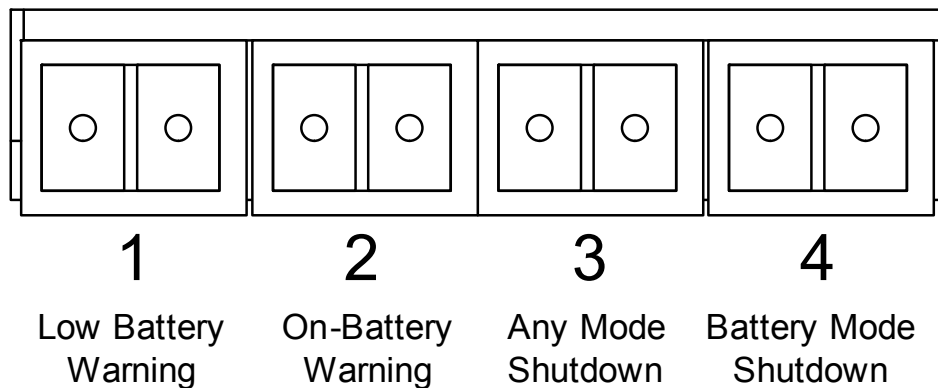

#### 6.2.1 Any Mode Shutdown

The purpose of Any Mode Shutdown is to shut down the UPS output by turning Off the rectifier, inverter and static switch so that there is no power to the loads.

Any Mode Shutdown can be operated locally or remotely:

- Local Any Mode Shutdown can be performed by shorting the pins in Set 3.
- Remote Any Mode Shutdown can be performed using a switch connected to the pins in Set 3 and mounted at a remote location.

Activation of the Any Mode Shutdown will be logged as an event in the event history log.



#### NOTE

*Remote Power Off will be performed either by NO or NC contact of Any Mode Shutdown.*

*The current limited source (+12VDC, 50mA) will be available from UPS.*

*The connection to UPS for remote connection will be via terminal block connector.*

*Any Mode Shutdown wiring must conform to all national, regional and local wiring codes and laws.*



#### WARNING

When the Auto-enable output option is selected and the UPS output is disabled using the pins in Set 3, the Liebert GXT3's output can turn On automatically and without warning if the connection to the pins in Set 3 is changed.



## 6.2.2 Battery Mode Shutdown

Battery Mode Shutdown permits shutting down the UPS by turning Off the rectifier, inverter and static switch so that there is no power to the load when the UPS is On Battery. The auxiliary power for the UPS will still be active.

Battery Mode Shutdown can be performed locally or remotely:

- Local Battery Mode shutdown can be performed by shorting the pins in Set 4.
- Remote Battery Mode Shutdown can be performed using a switch connected to the pins in Set 4 and mounted at remote location.

Activation of the Battery Mode Shutdown will be logged as an event in the event history log.



### NOTE

*Remote Power Off will be performed by NO contact.*

*The current limited source (+12VDC, 50mA) will be available from UPS.*

*The connection to the Liebert GXT3 for remote connection will be via terminal block connector.*

*Battery Mode Shutdown wiring must conform to all national, regional and local wiring codes and laws.*

*This signal must last for 1.5 seconds or longer.*

*A battery shutdown signal will not cause an immediate shutdown. It will start a 2-minute shutdown timer. This timer cannot be stopped once triggered. If the utility power returns during this countdown, the Liebert GXT3 will still shut down and must remain shut down for 10 seconds. Whether the UPS turns back On when the power is restored depends on the auto-restart setting.*

## 6.2.3 On Battery

On Battery signal is a Normally Open (NO) dry contact. When the UPS is supplying output power from the battery this dry contact will be closed.

## 6.2.4 Low Battery

Low Battery signal is a Normally Open (NO) dry contact. When the UPS is supplying output power from the battery and has reached the Low Battery Warning time selected in the configuration program, this dry contact will be closed.



### NOTE

*The rated values for the dry contacts are:*

- *Rated Voltage: 5V*
- *Working Voltage Range: 4.5-10V*
- *Rated Current: 30ma*

## 6.3 UPS IntelliSlot Communication Cards

The Liebert IntelliSlot port accepts three optional cards:

- Liebert IntelliSlot SNMP Card
- Liebert IntelliSlot Relay Card
- Liebert IntelliSlot 485 Card.

The Liebert IntelliSlot SNMP Card provides SNMP monitoring and control of the UPS across the network.

The Liebert IntelliSlot Relay Card provides dry contact relay outputs for custom-wired applications and delivers support for built-in shutdown for AS/400 systems.

The Liebert IntelliSlot 485 Card is used to connect the UPS and computer system.

Follow instructions provided with the Liebert IntelliSlot card to configure Liebert MultiLink, the UPS or any additional ancillary product for the Liebert GXT3. These instructions are available at

[multilink.liebert.com](http://multilink.liebert.com)

### 6.3.1 Liebert MultiLink

Liebert MultiLink continually monitors the UPS and can shut down your computer or server in the event of an extended power failure.

Liebert MultiLink can also be configured for use without the USB cable when the Liebert IntelliSlot SNMP/Web card is installed in the UPS. Additionally, Liebert MultiLink can be configured to coordinate shutdown across the network with other computers running Liebert MultiLink when you purchase a Liebert MultiLink License Kit. For more information about the Liebert IntelliSlot SNMP/Web Card and Liebert MultiLink License Kits, visit our Web site ([www.liebert.com](http://www.liebert.com)) or contact your local dealer or Emerson representative.

Several option cards are available for use in the Liebert IntelliSlot port of the Liebert GXT3. The Liebert IntelliSlot SNMP/Web Card provides SNMP and Web-based monitoring and control of the UPS across the network.

The Liebert IntelliSlot MultiPort 4 Card allows installing Liebert MultiLink software on four computers and coordinate shutdown in the event of a power failure.

The Liebert IntelliSlot Relay Card provides dry contact relay outputs for custom wired applications and delivers support for built-in shutdown for AS/400 systems.



## CAUTION

To maintain safety (SELV) barriers and for electromagnetic compatibility, signal cables should be shielded and run separate from all other power cables, where applicable.

### 6.4 Remote Emergency Power Off

The UPS is equipped with a Remote Emergency Power Off (REPO) connector.

The user must supply a means of interfacing with the REPO circuit to allow disconnecting the UPS input feeder breaker to remove all sources of power to the UPS and connected equipment to comply with national and local wiring codes and regulations.

Figure 19 REPO switch connection diagram

UPS ships with REPO jumper installed allowing the UPS to operate

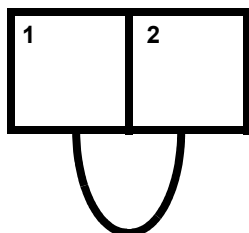

Normally Closed switch system  
(fail-safe)

Opening the REPO connection will disable the UPS. Manual restart using the front panel is required after the REPO connection is closed again.

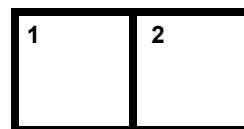

## CAUTION

To maintain safety (SELV) barriers and electromagnetic compatibility, signal cables should be shielded and run separately from power cables.

## 7.0 TROUBLESHOOTING

If any technical problems should occur, check the following before contacting Liebert technical support:

1. Is the mains voltage present at the UPS input?
2. Has the input fuse blown or have the circuit breakers tripped?
3. Has the UPS startup procedure been followed correctly?

When contacting Liebert technical support, have the following information to hand:

- Device model number
- Serial number (from the nameplate)
- Exact description of the problem (what loads are being operated, does the problem occur regularly or sporadically, etc.)

For descriptions of the indicators mentioned in the following table, see 'Controls and Messages'.

**Table 9 Troubleshooting - errors and corrective action**

Problem	Possible cause	Solution
No display No alarm (UPS switched Off)	Mains switched Off	Switch On main breaker
	No mains voltage present	Have mains inspected by a qualified technician
	Input fuse blown or input circuit breaker tripped	Replace with fuse of same type or switch On circuit breaker. If the problem persists, contact technical support.
UPS on LED does not light up, alarm beeps sound at intervals	No mains voltage present	UPS operation control panel
UPS on LED does not illuminate when mains voltage present, audible alarm active at intervals	Input fuse defective or input circuit breaker tripped	Replace with fuse of same type or switch On circuit breaker. If the problem persists, contact technical support
FAULT LED illuminates, alarm sounding constantly	UPS error	Contact technical support
	Overheating	Decrease ambient temperature
Autonomy less than specified	The fuse switch of the battery extension(s) is 'OPEN'.	Contact technical support.
	Batteries are not fully charged	Charge batteries (see 'Batteries') and test backup time. If the problem persists, contact technical support.
	Batteries are defective	Contact technical support
	Charging device is defective	Contact technical support
'OVERLOAD' message displayed	Overload at UPS output	Reduce load to the permissible value
No communication between UPS and PC	Wrong serial connection cable	Check whether the correct cable has been used (standard modem/null modem cables are not permissible)
	Interface on the PC is being used by another process or is defective	Check whether other software/service is accessing the interface on the PC; try selecting a different serial interface
	Interference on the data cable	Lay cable differently/Reinstall cabling

## 8.0 SPECIFICATIONS

**Table 10 UPS specifications**

Specification	Value
Rectifier	GXT3-10000T230
Nominal input voltage, VAC	230VAC Single Phase (L,N,G) 230/400 Three Phase (L1,L2,L3,N,G)
Input phases, VAC	Single phase or three phase, automatic detection
Input voltage	176-280V for 1x1 304-485V for 3x1
Nominal frequency, Hz	50/60 Auto selection
Frequency tolerance	Output frequency equals input frequency. When the input is nominal 50 or 60Hz $\pm 3.5$ Hz. Beyond $\pm 3.5$ Hz range, inverter free runs at nominal frequency.
<b>Maximum Input Power (Nominal Input Voltage, R Full Load)</b>	
Float (kVA) <sup>1</sup>	9900VA for 1x1; 10100VA for 3x1
Recharge (kVA) <sup>2</sup>	10460 VA for 1x1; 10900 VA for 3x1
Power factor (at nominal V, with R full load)	Single Phase Input: not less than 0.99 Three Phase Input: not less than 0.95
Input current distortion (with R full load) THDi <sup>3</sup>	Single Phase Input: < 5% Three Phase Input: < 31%
Inrush current (A) (typical)	67.5
<b>Battery Charger</b>	
Battery nominal voltage, VDC	240
Battery charger input voltage range, VDC	100-276
Output voltage, V	Multi-stage charging method
Charging time to 90% capacity in inverter mode, hr.	3
Charger output current (A <sub>DCaver</sub> ) (Amps)	Standard: 1.2A (1 Charger Board With Internal Batteries) Option: 4.0A (internal option)
<b>Inverter</b>	
Nominal power rating @40°C, kVA	10
Nominal active power rating, kW	9
Power factor	0.9
Overload - Inverter Mode for 1 minute for 10 seconds for 1 second At least 5 cycles	105 - 130% 131 - 150% 151 - 200% > 200%
Overload - Bypass Mode 20- seconds 2 seconds or breaker capacity	130 - 150% > 150%
Overload - Battery Mode for 30-60 seconds At least 5 cycles	105 - 125% > 125%
Short-circuit current for 5 cycles, typical	160A
Output voltage rating, VAC	220, 230, 240
Output frequency, Hz	50/60, auto selection
Voltage regulation over input voltage and battery voltage range with load between 0% and 100% of rating	$\pm 2\%$
Output frequency stability with mains synchronism (%)	$\pm 3.5$ Hz
Stability with internal quartz oscillator	0.1 Hz
Frequency Variation Rate	< 1 Hz/sec
Output Voltage Distortion THD-V	Full Resistive load < 3% Full RCD load < 5%
Load peak factor without derating	$\leq 3$ Ip/ Irms

Table 10 UPS specifications (continued)

Specification	Value
<b>Static Switch</b>	
Nominal frequency	50/60 Hz auto selection
Frequency tolerance	±3.5 Hz
Voltage tolerance	100V - 280V
Out-of-phase switching time (ms) in case of inverter fault and bypass is out of tolerance	No transfer
<b>Overload</b>	
Overload > 100%	Audible alarm
In-phase switching time - direct/conditioned (ms) <sup>4</sup>	Zero break
Condition/direct	Zero break
105% to 130%	1 minute
131% to 150%	10 seconds
151% to 200%	1 second
>200% (impact load)	At least 5 cycles
Maximum noise level at 1 meter front-side normal mode and battery mode	≤ 50dBA
Degree of protection	IP20
<b>Physical Characteristics</b>	
Dimensions, W x D x H, mm (in)	300 x 675 x 800 (11.8 x 26.6 x 31.5)
Color	Black
Weight with integrated batteries, kg (lb)	105 (231.5)
<b>Battery</b>	
Optimum battery temperature, °C (°F)	15 - 25 (59-77)
Power output	8.5kW
Recommended number of cells	120
End of discharge	200VDC
Battery type	HR 1234W F2 12V / 8.5Ah
Battery number	20
Discharging time	5 minutes
Auto battery missing detection	Yes
External Battery Cabinet	1Set / 2Set
Battery type	HR 1234W F2 12V / 8.5Ah
Battery number, pcs.	40 / 80
Dimensions, W x D x H, mm (in)	300 x 675 x 800 (11.8 x 26.6 x 31.5)
Color	Black
Weight with integrated batteries, kg (lb)	162 (357)
<b>Performance EN 62040-3</b>	
Dynamic characteristics	VFI - S S - 1 1 1
Step load response	—
Load 0% to 100% to 0%	±5% maximum, returns to static regulation within 200 ms.
Load 20% to 100% to 20%	±3% maximum, returns to static regulation within 200 ms.
<b>Startup Operation</b>	
Input AC < 100VAC or greater than 280VAC	UPS will not start
Input >176 or less than 276	UPS start enabled
Load 0% to 100% to 0%	±5% maximum, returns to static regulation within 200 ms.

1. Maximum input power (normal V, R full load)

$$\text{float (kVA)} = [\text{Pout (KW)} / \text{efficiency}] / \text{input\_power\_factor}$$

$$\text{Example for the 10kVA: float (kVA)} = (7,0 / 0,91) / 0,95 = 8100\text{VA}$$

2. Recharge (kVA) = [(Pout (KW) / efficiency) + P<sub>battchargerinput</sub>] / input\_power\_factor

$$\text{Example for the 10kVA: P}_{\text{battchargerinput}} = (2.5 \cdot 268) / \text{efficiency} = (2.5 \cdot 268) / 0,9 = 744\text{W recharge (kVA)} = [(7,0 \text{ (KW)} / 0,91) + 744] / 0,95 = 8880\text{VA}$$

3. THDi measure method is applied to EN61000-3-2, 1995

4. In-phase switching time direct / conditioned means time line (bypass) transferring to inverter

5. The expected battery life is defined at 20°C. For every increment of 10°C, above 20°C, the expected life is halved

**Table 11 Environmental data**

Environmental Parameter	Value
Operating Temperature, °C (°F)	0 to 40 (32 to 104) refer to <b>Table 13 - Operating temperature parameters</b>
Storage Temperature, °C (°F)	15 to 50 (5 to 122)
Relative Humidity	0-95% non-condensing
Operating Elevation	Up to 1000m (3281 ft) at 30°C (86°F) without derating
Audible Noise	<55 dBA, at 1 meter (39") from the rear; <50 dBA, at 1 meter (39") from the front or sides

**Table 12 Agency/safety compliance**

EMI/EMC/C-Tick EMC	IEC/EN/AS 62040-2 2nd Ed (Cat 2 – Table 6)
ESD	EN61000-4-2, Level 4, Criteria A
Radiated Susceptibility	EN61000-4-3, Level 3, Criteria A
Electrical Fast Transient	EN61000-4-4, Level 4, Criteria A
Surge Immunity	EN61000-4-5, Level 3, Criteria A
Transportation	ISTA Procedure 1A

**Table 13 Operating temperature parameters**

Ambient Temperature, °C (°F)	pf @30°C ±3°C (pf @ 86°F ±5.4°F)	pf @40°C ±3°C (pf @ 104°F ±5.4°F)
<b>10000T230</b>	0.9pf	0.8pf

**Table 14 Typical battery run times, minutes at 25°C (77°F), 100% resistive load**

Number of Batteries, Battery Cabinets	Load %							
	30%	40%	50%	60%	70%	80%	90%	100%
Internal Battery	21	14.5	10.75	8.5	6.5	5	3.75	3
Internal Battery + 1 External Battery Cabinet	43	33	26	21	17	13	11.5	10
Internal Battery + 2 External Battery Cabinets	74.5	55	41.5	33	28.5	24	21	18
Internal Battery + 3 External Battery Cabinets	95	70	58	48	40	34	29.5	26
Internal Battery + 4 External Battery Cabinets	99.5	96	72.5	62	51	45	40	34



# Ensuring The High Availability Of Mission-Critical Data And Applications.

Emerson Network Power, the global leader in enabling business-critical continuity, ensures network resiliency and adaptability through a family of technologies—including Liebert power and cooling technologies—that protect and support business-critical systems. Liebert solutions employ an adaptive architecture that responds to changes in criticality, density and capacity. Enterprises benefit from greater IT system availability, operational flexibility and reduced capital equipment and operating costs.

## Technical Support / Service

### Web Site

[www.liebert.com](http://www.liebert.com)

### Monitoring

[liebert.monitoring@emerson.com](mailto:liebert.monitoring@emerson.com)

800-222-5877

Outside North America: +00800 1155 4499

### Single-Phase UPS & Server Cabinets

[liebert.upstech@emerson.com](mailto:liebert.upstech@emerson.com)

800-222-5877

Outside North America: +00800 1155 4499

### Three-Phase UPS & Power Systems

800-543-2378

Outside North America: 614-841-6598

### Environmental Systems

800-543-2778

Outside the United States: 614-888-0246

## Locations

### United States

1050 Dearborn Drive

P.O. Box 29186

Columbus, OH 43229

### Europe

Via Leonardo Da Vinci 8

Zona Industriale Tognana

35028 Piove Di Sacco (PD) Italy

+39 049 9719 111

Fax: +39 049 5841 257

### Asia

29/F, The Orient Square Building

F. Ortigas Jr. Road, Ortigas Center

Pasig City 1605

Philippines

+63 2 687 6615

Fax: +63 2 730 9572

While every precaution has been taken to ensure the accuracy and completeness of this literature, Liebert Corporation assumes no responsibility and disclaims all liability for damages resulting from use of this information or for any errors or omissions.

© 2010 Liebert Corporation

All rights reserved throughout the world. Specifications subject to change without notice.

® Liebert is a registered trademark of Liebert Corporation.

All names referred to are trademarks or registered trademarks of their respective owners.

SL-23442\_REV1\_07-10

## Emerson Network Power.

The global leader in enabling *Business-Critical Continuity*™

■ AC Power

■ Embedded Computing

■ Outside Plant

■ EmersonNetworkPower.com

■ Racks & Integrated Cabinets

■ Connectivity

■ Embedded Power

■ Power Switching & Controls

■ Services

■ DC Power

■ Infrastructure Management & Monitoring

■ Precision Cooling

■ Surge Protection