

Installation Instructions

Original Instructions



Allen-Bradley
by ROCKWELL AUTOMATION



Lifeline 5 Cable-pull Safety Switch

Catalog Numbers 440E-LL5SS8, 440E-LL5SS5, 440E-LL5SE8, 440E-LL5SE5, 440E-LL5SN8, 440E-LL5SN5

Topic	Page
Summary of Changes	1
Introduction	1
Specifications	2
Mounting	2
Approximate Dimensions	2
Wiring	2
OSSD Test Pulses	3
Diagnostic	3
Function Overview	3
Indicators	3
Installation of Rope/Cable	4
Cable Considerations/Thermal Expansion	4
Timing Diagram	6
Series Circuit	6
Application Wiring Examples	7
Recommended Safety Control Interfaces	13
Maintenance	13
Repair	13
Declaration of Conformity	13
Additional Resources	13

Summary of Changes

This publication contains the following new or updated information. This list includes substantive updates only and is not intended to reflect all changes.

Topic	Page
Updated Certifications	2
Updated Declaration of Conformity	13



ATTENTION: Read this document and the documents that are listed in [Additional Resources on page 13](#) about the installation, configuration, and operation of this equipment before you install, configure, operate, or maintain this product. Users are required to familiarize themselves with installation and wire instructions and requirements of all applicable codes, laws, and standards.

Suitably trained personnel are required to install, adjust, put into service, use, assemble, disassemble, and maintain this equipment in accordance with the applicable code of practice.

The protection that is provided by the equipment can be impaired if the equipment is used in a manner that the manufacturer has not specified.

Introduction



ATTENTION: Do not attempt to install this device unless the installation instructions have been studied and understood. This document acts as a guide for a typical installation and is available at rok.auto/literature.

Standard Switch

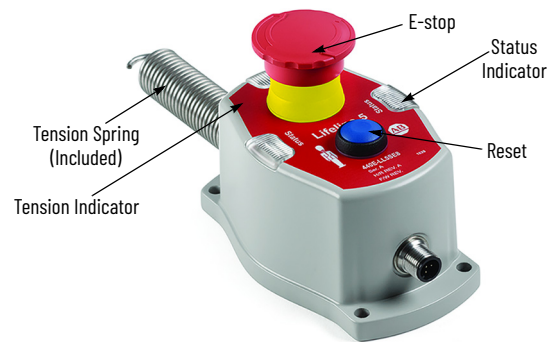

Stainless Steel Switch

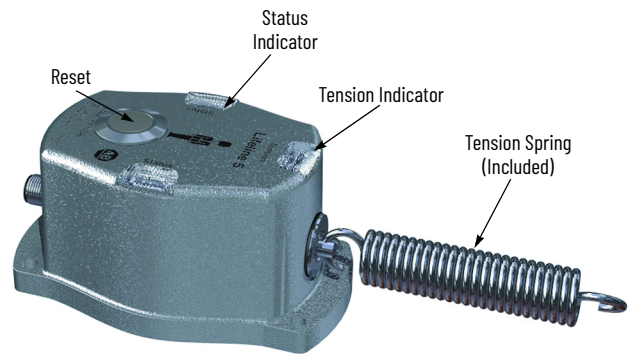

It is required that installation is in accordance with these instructions and implemented by qualified personnel.

This device is intended to be part of the safety-related control system of a machine. Before installation, a risk assessment must be performed to determine whether the specifications of this device are suitable for all foreseeable operational and environmental characteristics of the application. See the Specifications for certification information and ratings.

Use appropriate screws, bolts, or nuts that are fitted by tools to mount the switch to avoid the risk of tampering. Do not over torque the mounting hardware.

Specifications

Attribute	Aluminum Housing with E-stop	Aluminum Housing without E-stop	Stainless Steel Housing without E-stop
Safety Ratings			
Standards Safety classification	PLe Cat 4 according to EN ISO 13849-1, SIL CL 3 per IEC 62061 and IEC 61508, NFPA 79 The intent of the operational functionality that EN ISO 13850 and IEC 60947-5-5 require is achieved by using electronic technology.		
Functional safety data	PFH ₀ = 1.32E-9 (average frequency of a dangerous failure per hour) T1 = 20 (Proof test interval)		
Certifications	CE Marked for all applicable directives, UKCA marked for all applicable regulations, cULus Listed (UL 508), CCC Marked, and TUV Certified.		
Operating Characteristics			
Cable span	100 m (328 ft)		
Tension force to run position	135 N (30.35 lbf)		
Tension force to lockout	195 N (43.84 lb)		
Operating voltage	24V DC +10%/-15% Class 2 SELV or PELV power supply		
Response time (off)	60 ms		
Switches connected in series	Response time-off is 5 ms for each additional switch		
Utilization category according to Ue Ie	DC-12 and DC-13 24V 200 mA		
Frequency of operating cycle	0.25 Hz		
Off-state output current	< 0.5 mA		
Outputs			
Safe state	De-energized (2 x PNP, 0V), AUX energized (1 x PNP, 24V)		
Run state	Energized (2 x PNP, 24V), AUX de-energized (1 x PNP, 0V)		
Tension	Energized (1 x PNP, 24V)		
No-load supply current	< 50 mA		
Load current	200 mA maximum		
Voltage drop	< 2V		
Mechanical			
Housing material	Aluminum		304 stainless steel
Environmental			
Operating temperature	-20...+75 °C (-4...+167 °F)		
Operating humidity	5...95% relative		
Washdown rating	IP66	IP66	IP66, IP69K
Shock and vibration	IEC 60068-2-27: 30 g (1.05 oz), 11 ms IEC 60068-2-6: 10...500 Hz		
Pollution degree	IEC 60947-1: 3		
Attribute			
	440E-LL5SS8, 440E-LL5SS5, 440E-LL5SE8, 440E-LL5SE5, 440E-LL5SN8, 440E-LL5SN5		
Electromagnetic Compatibility (EMC)			
Electrostatic Discharge ESD	IEC 61000-4-2: air discharge Per IEC 61326-1 (functional): 8 kV Per IEC 61000-6-7 (fail-safe): 8 kV IEC 61000-4-2: contact discharge Per IEC 61326-1 (functional): 4 kV Per IEC 61000-6-7 (fail-safe): 6 kV		
Radiated EMF immunity	IEC 61000-4-3 Per IEC 61326-1 (functional): 10V/m Per IEC 61000-6-7 (fail-safe): 20V/m		
Electrical Fast Transient/Burst Immunity	IEC 61000-4-4 Per IEC 61326-1 (functional): 2 kV/5 kHz Per IEC 61000-6-7 (fail-safe): 2 kV/5 kHz		
Conducted Immunity	IEC 61000-4-6 Per IEC 61326-1 (functional): 10V Per IEC 61000-6-7 (fail-safe): 20V		
Rated Impulse Withstand Voltage	IEC 60947-1: 1 kV		
Protection	Short circuit, overload, reverse polarity, overvoltage, loss of ground		

Mounting

We recommend using M5 or #10-32 bolts to mount the sensor to the frame of the machine.

Approximate Dimensions

Figure 1 - Standard Housing [mm (in.)]

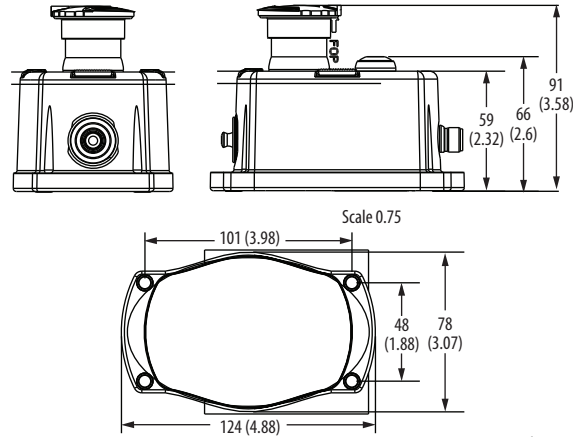

The spring rate is 2.1 N/mm (12 lbf/in.) and the material is carbon steel/spring steel.

Figure 2 - Stainless Steel Housing [mm (in.)]

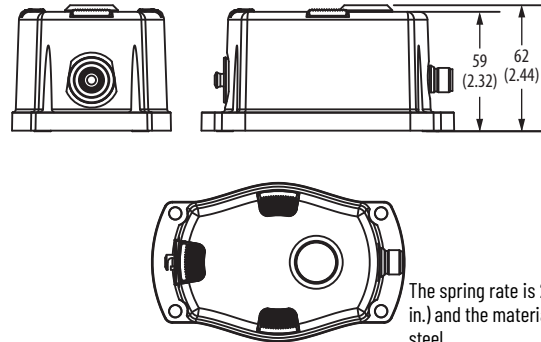

The spring rate is 2.1 N/mm (12 lbf/in.) and the material is 302 stainless steel.

Wiring

Table 1 - 8-pin Connection

	Pin	Wire Color	Signal
	1	White	Auxiliary Output
	2	Brown	24V DC
	3	Green	Tension Output
	4	Yellow	Safety OSSD 2 Input
	5	Gray	Safety OSSD 1 Output
	6	Pink	Safety OSSD 2 Output
	7	Blue	0V
	8	Red	Safety OSSD 1 Input

Description	Temperature Rating	Jacket Material	Coupling Nut	Cat. No.
M12 8-pin cordset	-20...+105 °C (-4...+221 °F)	PVC	Epoxy-coated zinc	889D-F8AB-2
			Stainless steel	889DS-F8AB-2

Replace the 2 with 5 (5 m [16.4 ft]) or 10 (10 m [32.8 ft]) for standard cable lengths.

Table 2 - 5-pin Connection

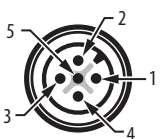
	Pin	Color	Signal
	1	Brown	+24V
	2	White	Safety OSSD 1 Output
	3	Blue	0V
	4	Black	Safety OSSD 2 Output
	5	Gray	Auxiliary Output

Description	Temperature Rating	Jacket Material	Coupling Nut	Cat. No.
M12 5-pin cordset	-20...+105 °C (-4...+221 °F)	PVC	Epoxy-coated zinc	889D-F5AC-2
			Stainless steel	889DS-F5AC-2
M12 4-pin cordset	-50...+105 °C (-58...+221 °F)	TPE	Stainless steel	889DS-F4HJ-2

Replace the 2 with 5 (5 m [16.4 ft]) or 10 (10 m [32.8 ft]) for standard cable lengths.

IMPORTANT If you do not require the auxiliary signal, a 4-pin cordset (catalog number 889D-F4AC-2) can be used. For low temperature applications, use a 4-pin cordset (catalog number 889DS-F4HJ-2).

The recommended patchcord for use with ArmorBlock® Guard I/O™ is 2 m (6.5 ft) - 889D-F4ACDM-2. Replace the 2 with 0M3 (0.3 m [0.98 ft]), 1 (1 m [3.28 ft]), 5 (5 m [16.4 ft]), or 10 (10 m [32.8 ft]) for standard cable lengths.

OSSD Test Pulses

Test pulses appear on each OSSD output. These pulses are approximately every 60 ms. The times that are shown are approximate and depend on the processing of the safety-related status.

Figure 3 - Individual Pulses

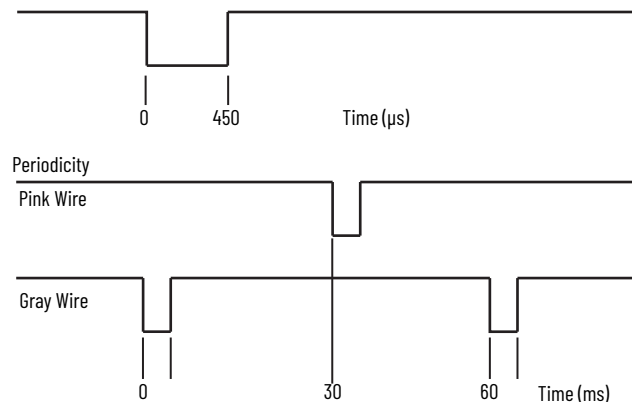

Diagnostic

Table 3 - Unit Indicators

State	Status	Troubleshooting
Off	Not powered	Normal functions
Red	OSSD not active	
Green	OSSD active	
Green flash	Power up test or OSSD inputs not valid	Check 24V DC or OSSD inputs (yellow or red wire)
Red flash	1 Hz flash OSSD fault	OSSD fault — check that OSSD outputs are not shorted to GND, 24V DC or each other.
	4 Hz flash internal fault	Cycle power.
	4 Hz flash internal fault	Press the E-stop button, cycle power, and twist-to-release E-stop. ⁽¹⁾

(1) Firmware revision 1.005 or higher

Function Overview

A Lifeline™ 5 cable-pull system consists of the Lifeline 5 safety cable-pull switch, red colored rope/cable, and supports (eyebolts and pulleys). The Lifeline 5 meets the intent of the international requirements according to IEC 60947-5-5 and EN ISO 13850.

Function Safety

Table 4 describes the demand on the safety switch that results in a stop function and how to reset that function.

Table 4 - Safety Function

Function	Result	Restore to Normal Operation
Actuation of rope/cable	Safety outputs OFF state	Press the Reset button
E-stop pressed		Rotating the E-stop button clockwise
Safety OSSD inputs off and not floating		Turn on OSSD inputs
Safety OSSD input wires floating		Connect input wires

Integrated Emergency Stop Push Button

The Lifeline 5 safety cable-pull switch is offered with a twist release E-stop push button that can be pressed in emergency situations to stop the machine. After E-stop actuation, the safety outputs remain in the off state and can only be reset manually by rotating the emergency stop push button clockwise.



Indication of Rope Tension

During installation/adjustment of the rope/cable assembly, the correct tension of the rope can be checked by observing the tension indicator. During setup, the tension indicator flashes at 1 Hz and the tension output pulses at the same rate. This output can be wired to an indicator light to help with initial setup and diagnostics. As the tension is increased on the rope/cable, the tension indicator flash rate increases. When the tension indicator turns off, the sensor is properly tensioned.

Margin Indication the Rope Tension

If the status indicator is green and the tension indicator flashes amber, the rope/cable requires maintenance/adjustment before the machine shuts down. This output can be used as an indication signal or be connected directly to an indicator light.

Indicators

Table 5 - 8-pin Connector Functions

Function	Switch Outputs			Status Indicators	
	Safety	Auxiliary	Tension	Status	Tension
E-stop pressed	Off	On	Off	Red	Off
Sensor not tensioned/cable cut	Off	On	On	Red	Amber flash
Low tension indication	On	Off	On	Green	Amber flash
Sensor tensioned properly	On	Off	Off	Green	Off
High tension indication	On	Off	On	Green	Amber flash
Cable pulled/tripped	Off	On	Off	Red	Off
Safety OSSD inputs not connected	Off	On	Off	Flashing green	Off

Table 6 - 5-pin Connector Functions

Function	Switch Outputs		Status Indicators	
	Safety	Auxiliary	Status	Tension
E-stop pressed	Off	On	Red	Off
Sensor not tensioned/ cable cut	Off	On	Red	Amber flash
Low tension indication	On	Off	Green	Amber flash
Sensor tensioned properly	On	Off	Green	Off
High tension indication	On	Off	Green	Amber flash
Cable pulled/tripped	Off	On	Red	Off

Status indicator flashes red, see [Diagnostic on page 3](#).

Installation of Rope/Cable

Attach the tension spring to the eye hook on the front of the switch, as shown in the following image.



ATTENTION: The sensor must not be used without this spring attached.

IMPORTANT The first eyebolt must be located 300 mm (11.8 in.) from the switch eyelet. This distance provides for a straight and efficient pulling action on the sensor.

Additional eyebolts are spaced 2...3 m (6...9 ft) apart to help keep the perpendicular pull force within IEC 60947-5-5 specifications of 200 N (45 lbf) and 400 mm (15.75 in.).

EN ISO 13850 standard requires that the full length of the cable is within view when the reset is pressed. Or the machine must be inspected over the whole length of the cable, before and after resetting.

Install inside and outside pulley so cable can go around corners or whenever direction is changed, even slightly.

Set/Adjust the Cable Tension

Power up the Switch ([Application Wiring Examples on page 7](#))

The status indicator becomes steady red and the tension indicator begins to blink amber/1 Hz rate.

Slowly increase the tension on the cable. The tension indicator blink rate increases as the tension is increased. When the tension indicator turns off, the sensor is properly set.

Press the Reset button. The status indicator turns green (the reset button must be pressed between 125 ms and 3 seconds for the sensor to be reset). The tension is set.

Verify the System

When the installation is complete, you have performed a thorough functional test. This test includes checking all types and directions of pull over the length of the cable.

IMPORTANT EN ISO 13850 requires the full length of the cable to be within view when the reset is pressed. If it is not, the machine must be inspected over the whole length of the cable, both before and after resetting.

Cable Considerations/Thermal Expansion

The cable is the actual interface with the user, and is typically red plastic coated and less than 4 mm (0.16 in.) in diameter. The cable is installed between the switch at one end and a support at the opposite end. It is important that the support for the cable is sturdy enough to handle the force that is required to operate the switch.

Temperature effects on the cable are important to note when configuring a system.

EXAMPLE:

A cable that runs along a conveyor is 20 m (65.6 ft). After the tension is adjusted properly, the Lifeline 5 safety cable-pull switch can accommodate a temperature variance from -32...+48 °C (-26...+118 °F) without readjustment required (see [Figure 4](#)).

Another consideration of the cable is that when it is pulled with great force, the cable can initially expand or stretch and affect system setup. It is recommended that the cable is forcefully pulled before tuning the cable tension with the turnbuckle. This step exposes areas in the system that initially stretch or expand. Adjustments can then be made to take up the added slack.

Figure 4 - Thermal Expansion Chart

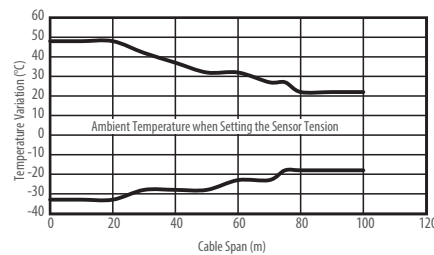
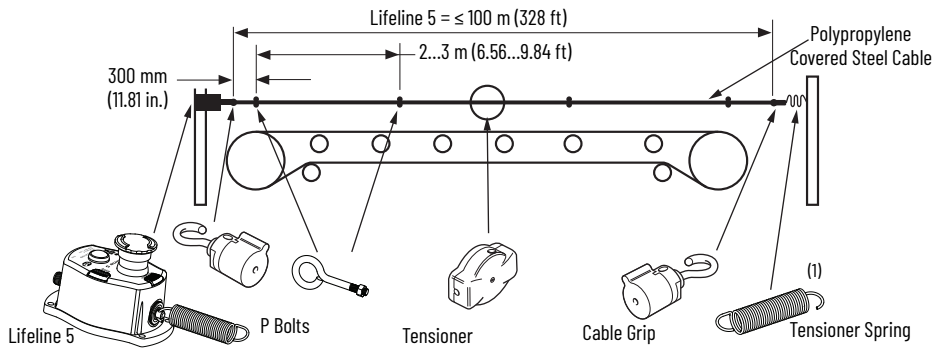

Figure 5 - Typical Mounting Example with One Switch Using Lifeline Rope Tensioner System (LRTS)



(1) For this installation example, use catalog number 440E-ASPRING for the standard version and catalog number 440E-ASPRINGSS for the stainless steel version.

Figure 6 - Typical Mounting Example with Two Switches Using the LRTS

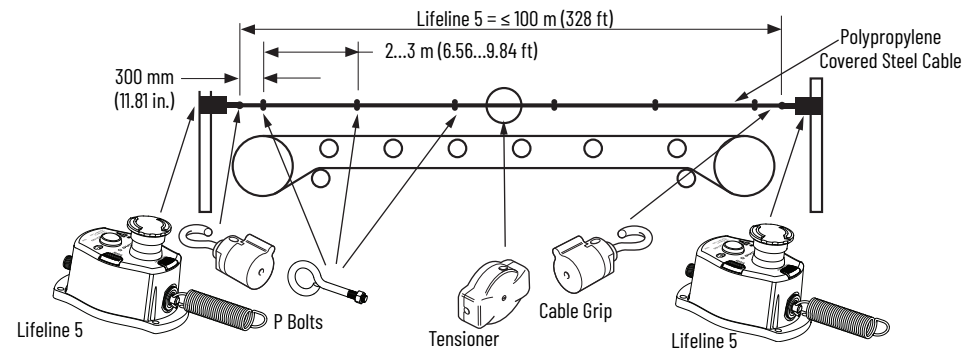
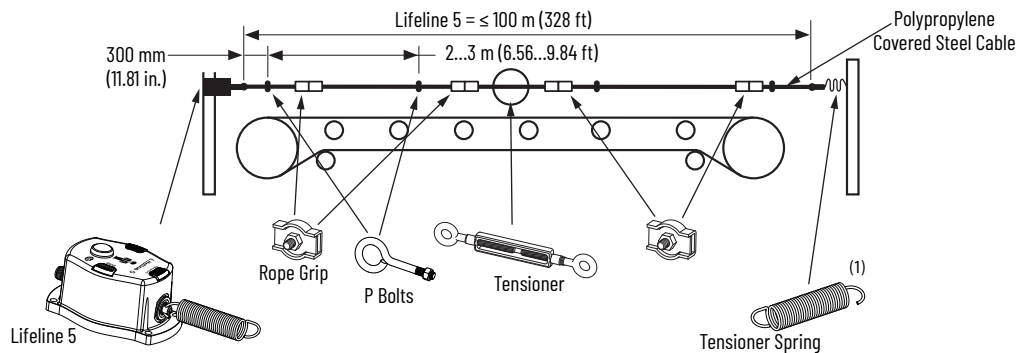
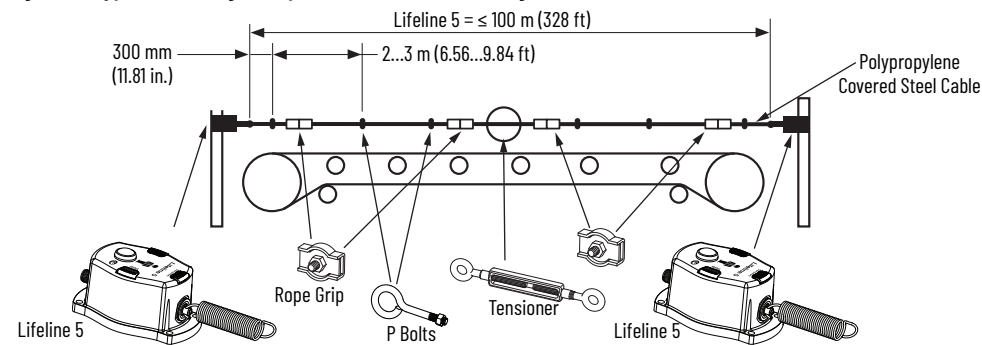

Figure 7 - Typical Mounting Example with One Switch Using the Stainless Steel Installation Kit



(1) For this installation example, use catalog number 440E-ASPRING for the standard version and catalog number 440E-ASPRINGSS for the stainless steel version.

Figure 8 - Typical Mounting Example with Two Switches Using the Stainless Steel Installation Kit



A secondary spring can be used when it is likely that actuation is attempted by pulling the wire along its axis. When you pull the wire in either direction, it generates the emergency stop command.

The choice between two switches or one switch is a matter of a risk assessment while considering the probability of a trapped rope along the span.

Timing Diagram

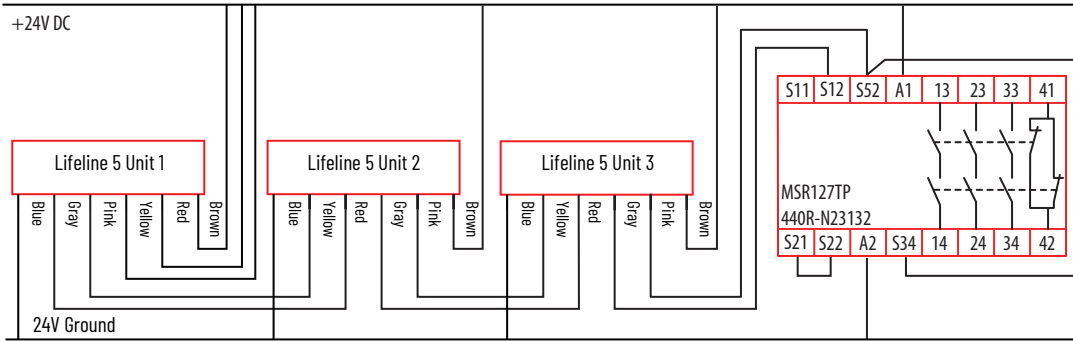

Response Time: Safety Outputs Turn OFF

Initial Conditions: All Lifeline 5 and tensioned properly.

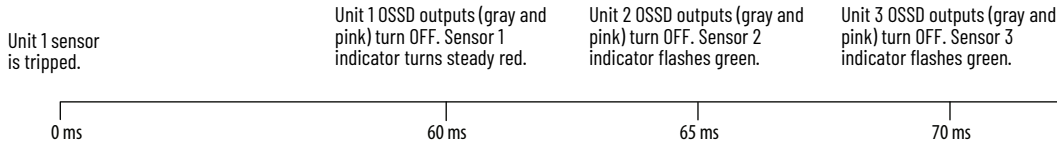

Series Circuit

Consideration must be given to the protection of the wiring. For example, by using wire duct, conduit, shielded cable, separation, or other means to help prevent faults or to confirm detection of faults (see ISO 13849-2, Table D.4).

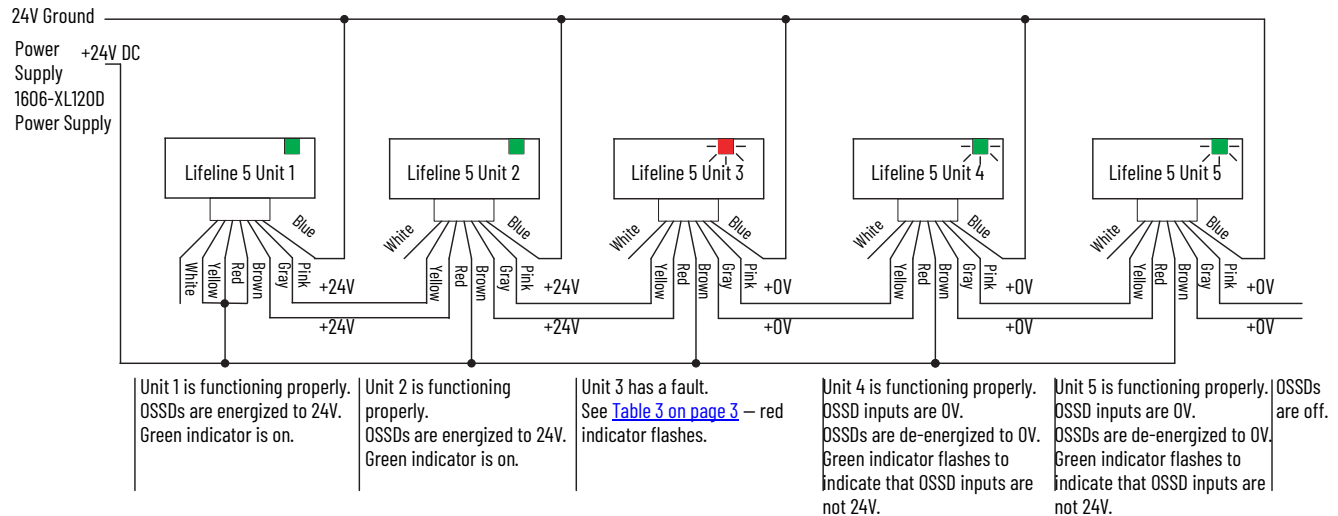

Safety Rating Note: Series circuits that contain only devices having OSSD outputs can be used in safety functions, which require up to PLe per ISO 13849-1.

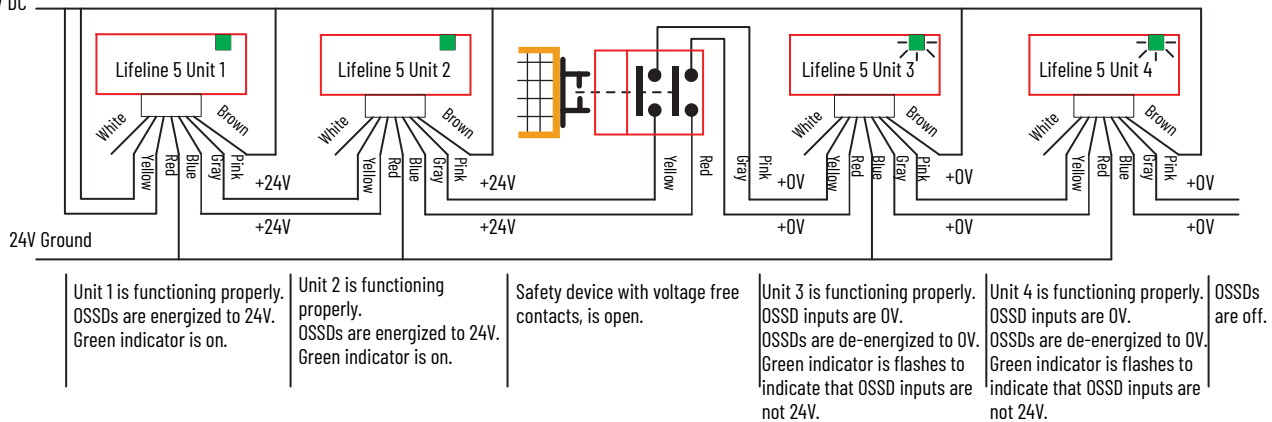

Safety Rating Note: A maximum safety function rating of PLd is achievable depending on the installation details when wiring the series circuits that contains voltage from contacts.

Application Wiring Examples

Wiring to MSR127 Safety Relay (M12 8-pin Version)

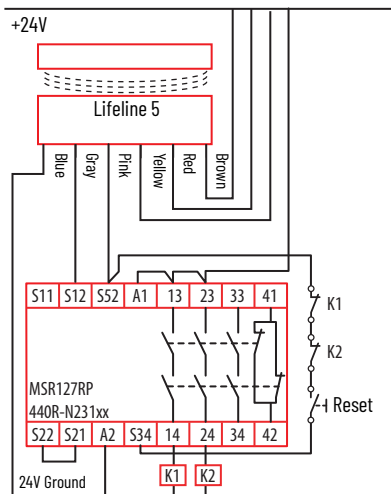

MSR127RP with one Sensor, Monitored Manual Reset, Driving 100S, or 700S Safety Relays.

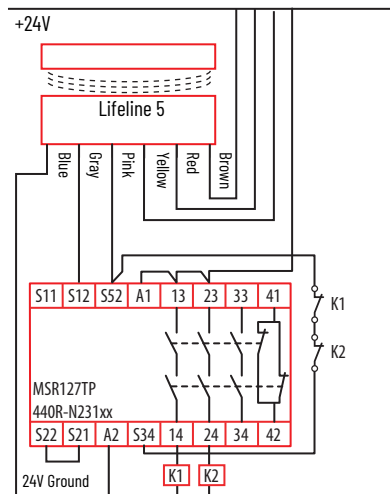

MSR127RP with one Sensor, Automatic Reset, Driving 100S, or 700S Safety Relays.

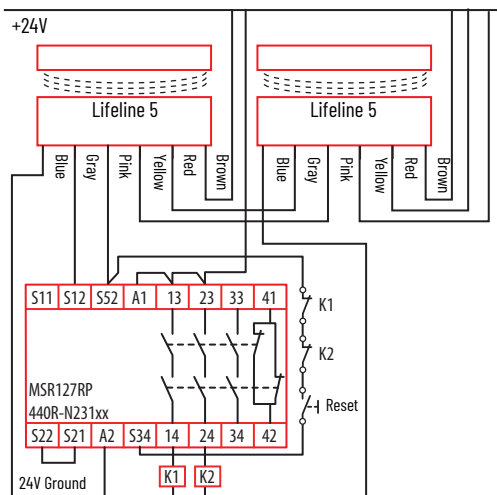

MSR127RP with one Sensor, Monitored Manual Reset, Driving 100S or 700S Safety Relays.

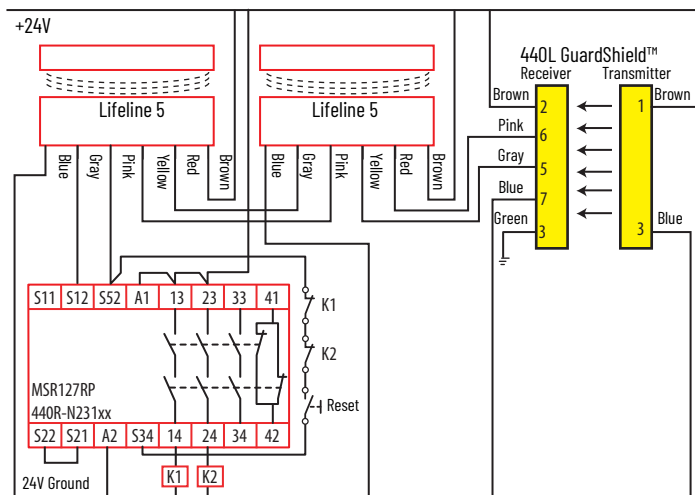

MSR127RP with two Sensors and one 440L Light Curtain in Series, Monitored Manual Reset, Driving 100S or 700S Safety Relays.

IMPORTANT The light curtain must be last (the furthest from MSR127 safety relay).

Guardmaster SI or DI Safety Relay Wiring (M12 5-pin Version)

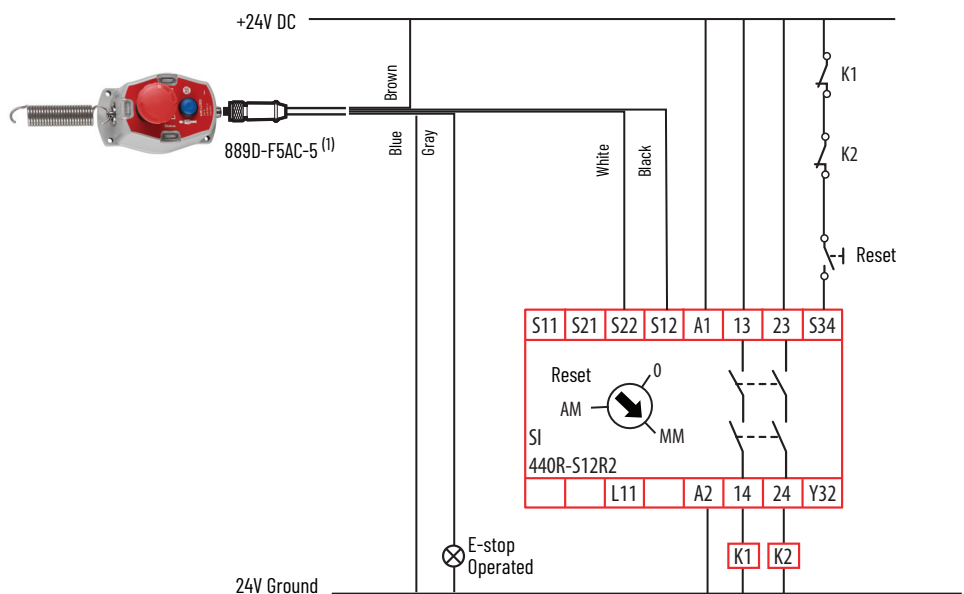
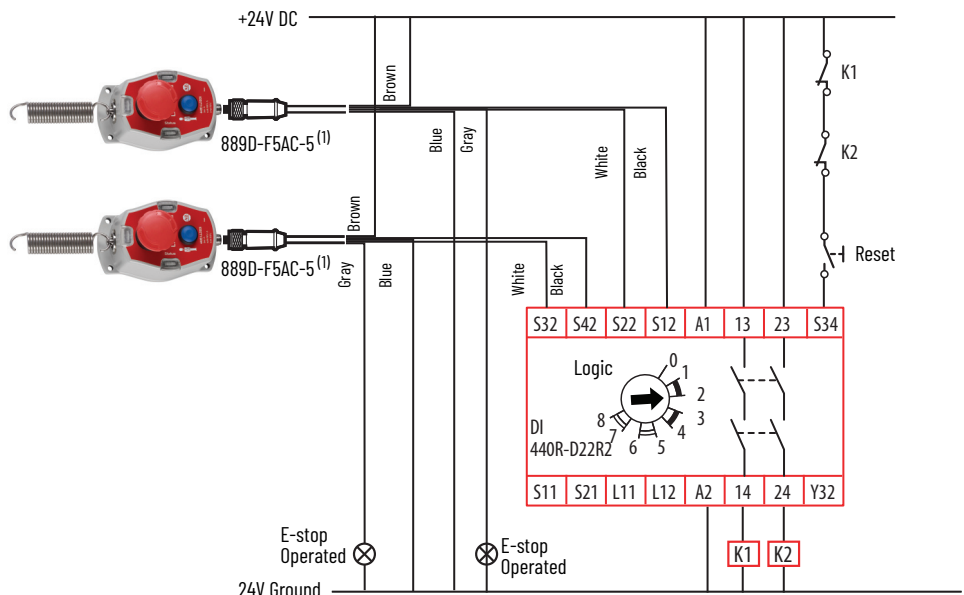

(1) For low temperature applications, use 889DS-F4HJ-2 instead of 889D-F5AC-5.

Guardmaster SI or DI Safety Relay Wiring (M12 8-pin Versions)

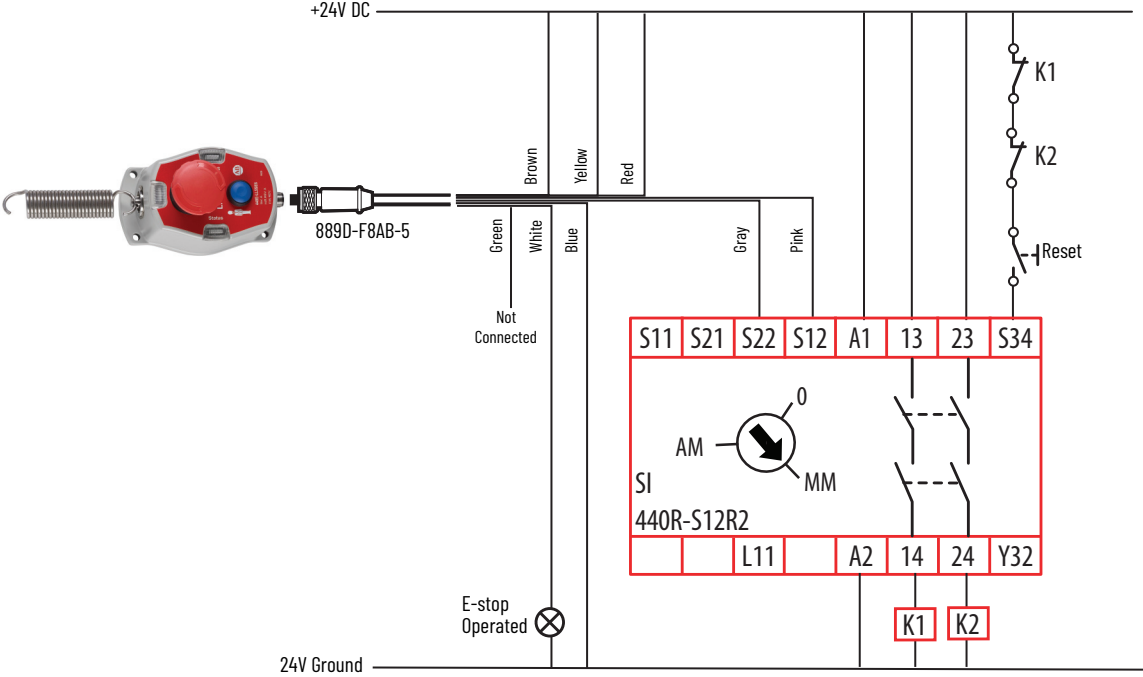
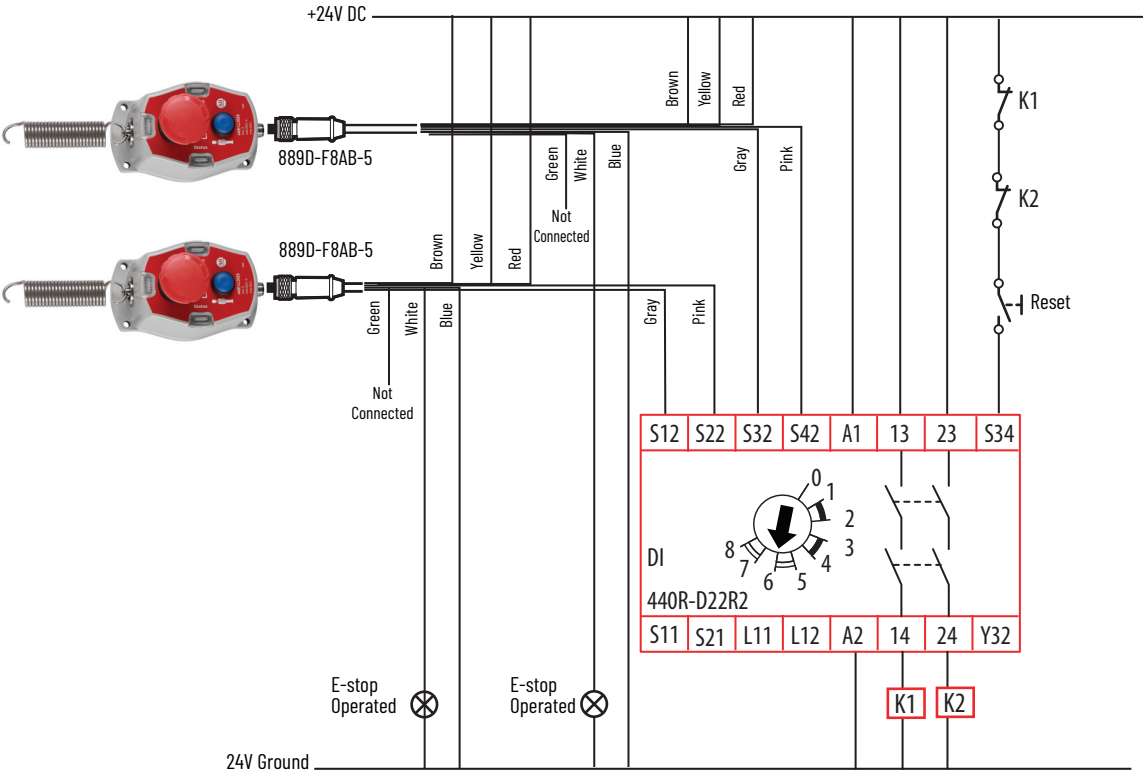

CR30 Software Configurable Relay Wiring (M12 5-pin Versions)

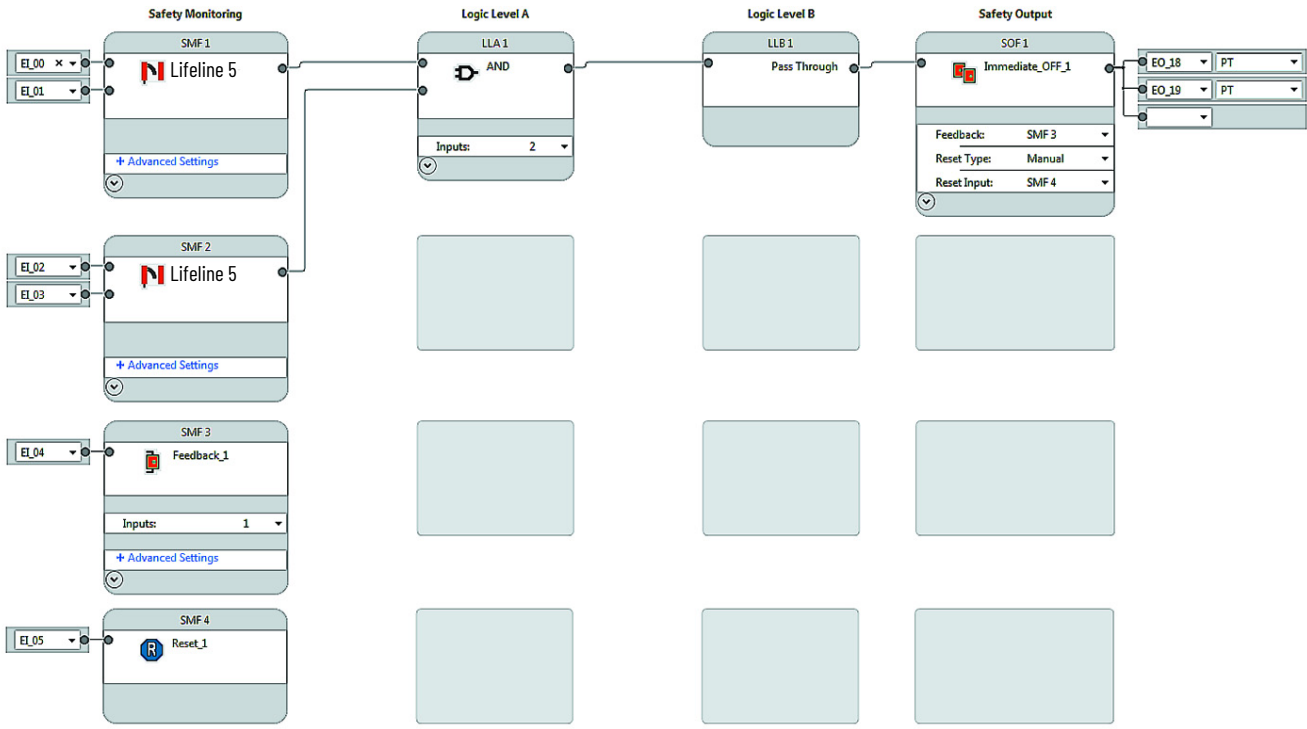
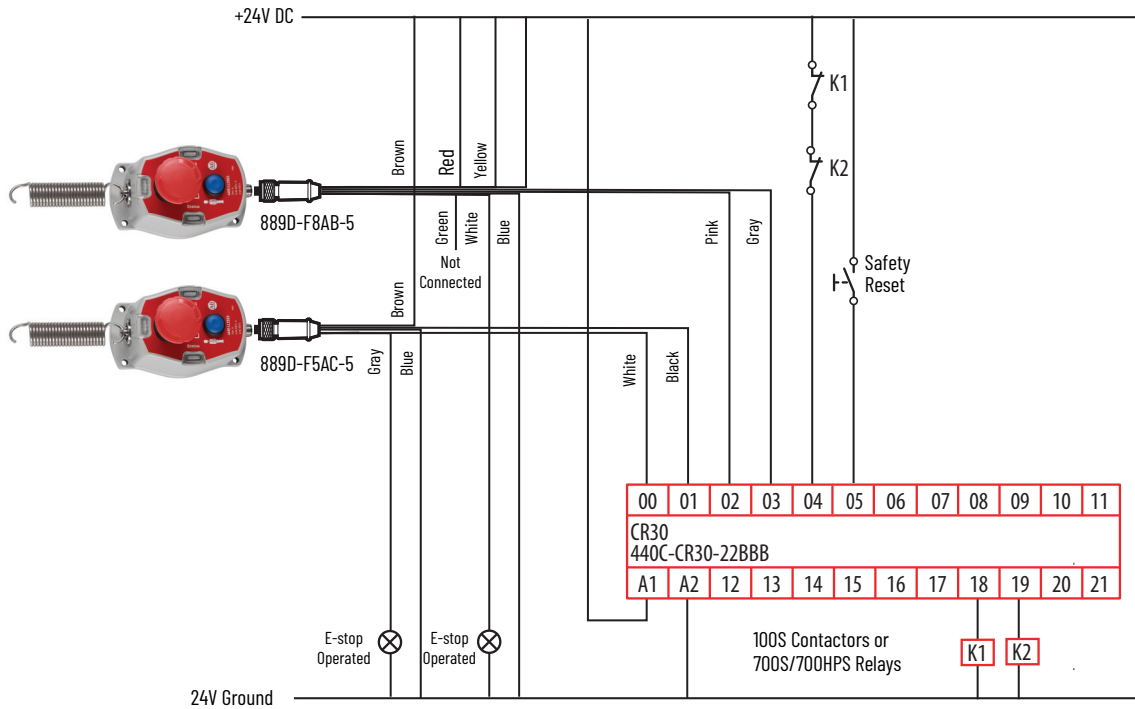

1734 POINT Guard I/O Wiring (M12 5-pin Versions)

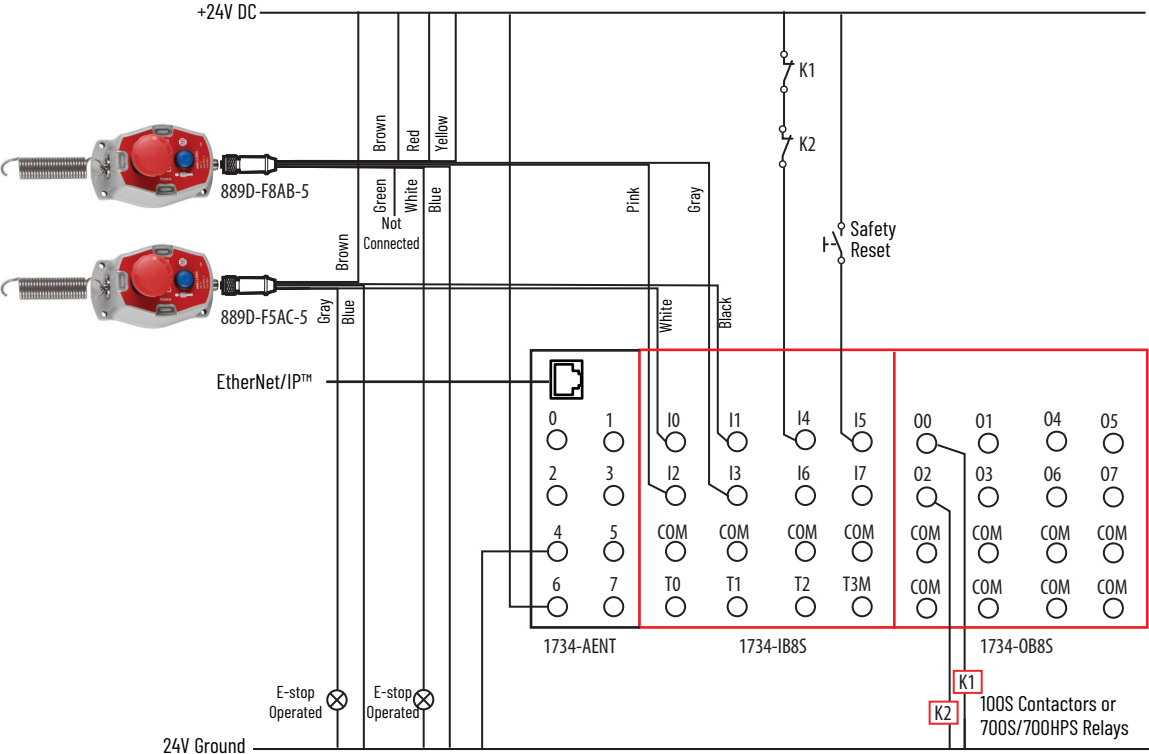

Point	Point Operation		Point Mode	Test Source	Input Delay Time (ms)	
	Type	Discrepancy Time (ms)			Off->On	On->Off
0	Equivalent	10	Safety	None	0	6
1	Equivalent	10	Safety	None	0	6
2	Equivalent	10	Safety	None	0	6
3	Equivalent	10	Safety	None	0	6
4	Single	0	Standard	None	0	0
5	Single	0	Standard	None	0	0
6	Single	0	Not Used	None	0	0
7	Single	0	Not Used	None	0	0

Set On->Off Input Delay Time to 6 ms to ignore the OSSD output test pulses.

1732DS/ES ArmorBlock Guard I/O Wiring (M12 5-pin Versions)

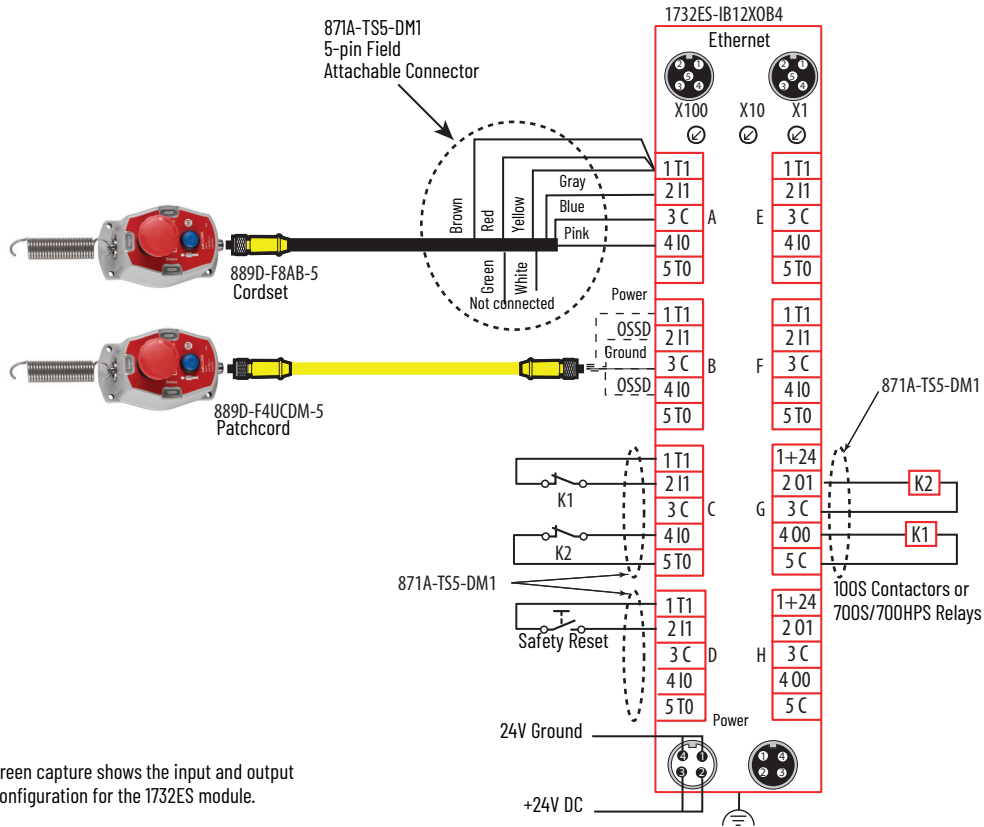

The screen capture shows the input and output configuration for the 1732ES module.

Point	Point Operation		Point Mode	Test Source	Input Delay Time (ms)	
	Type	Discrepancy Time (ms)			Off->On	On->Off
0	Equivalent	10	Safety	None	0	6
1	Equivalent	10	Safety	None	0	6
2	Equivalent	10	Safety	None	0	6
3	Equivalent	10	Safety	None	0	6
4	Equivalent	10	Safety Pulse Test	4	0	0
5	Equivalent	10	Safety Pulse Test	5	0	0
6	Single	0	Standard	None	0	0
7	Single	0	Not Used	None	0	0
8	Single	0	Not Used	None	0	0
9	Single	0	Not Used	None	0	0
10	Single	0	Not Used	None	0	0
11	Single	0	Not Used	None	0	0

Point	Point Mode
0	Not Used
1	Power Supply
2	Not Used
3	Power Supply
4	Pulse Test
5	Pulse Test
6	Not Used
7	Power Supply

Point	Point Operation	
	Type	Point Mode
0	Dual	Safety
1	Dual	Safety
2	Dual	Not Used
3	Dual	Not Used

Recommended Safety Control Interfaces

We recommend Guardmaster® safety relays (DI, DIS, SI, CR30), Minotaur™ safety relays (MSR126, MSR127, MSR131, MSR138), SmartGuard™ controller, 1791DS/ES CompactBlock™ Guard I/O™ modules, 1732DS/ES ArmorBlock Guard I/O module, 1734 POINT Guard I/O™ modules.

Maintenance

Frequency	Description
Every month	<ul style="list-style-type: none"> Check the correct operation of the switching circuit. Check for signs of abuse or interference. Inspect the switch casing for damage. Of particular importance is damage, which causes loss of sealing at the lid or conduit entry.
Every 5 years	<ul style="list-style-type: none"> Check the correct operation of the switching circuit. Check for signs of abuse or interference. Inspect the switch casing for damage. The switch must be disconnected and readjusted.

Repair

If there is any malfunction or damage, no attempts at repair can be made. The unit must be replaced before machine operation is allowed.

Declaration of Conformity

CE Conformity

Rockwell Automation declares that the products that are shown in this document are in compliance with the Essential Health and Safety Requirement (EHSRs) of the European Machinery Directive 2006/42/EC.

For a comprehensive CE certificate visit: rok.auto/certifications

UKCA Conformity

Rockwell Automation declares that the products that are shown in this document are in compliance with the Supply of Machinery (Safety) Regulation (2008 No. 1597).

For a comprehensive UKCA certificate visit: rok.auto/certifications

Additional Resources

To download publications, visit rok.auto/literature and search for the following publication numbers.

Resources	Description
Lifeline 5 Cable-pull Safety Switch Product Information, publication 440E-PC002	Provides the installation procedure for the Lifeline 5 switch.
Cable (Rope) Pull Switches Technical Data, publication 440E-TD001	Provides specification and selection information for cable (rope) pull switches.
Functional Safety Data Sheet, publication SAFETY-SR001	Provides functional safety data for Rockwell Automation products.
Industrial Automation Wiring and Grounding Guidelines, publication 1770-4.1	Provides general guidelines for installing a Rockwell Automation® industrial system.
Product Certifications website rok.auto/certifications	Provides declarations of conformity, certificates, and other certification details.

Waste Electrical and Electronic Equipment (WEEE)







At the end of life, this equipment should be collected separately from any unsorted municipal waste.

Rockwell Automation maintains current product environmental compliance information on its website at rok.auto/pec.

Your comments help us serve your documentation needs better. If you have any suggestions on how to improve our content, complete the form at rok.auto/docfeedback.
For technical support, visit rok.auto/support.

Rockwell Otomasyon Ticaret A.Ş. Kar Plaza İş Merkezi E Blok Kat:6 34752 İçerenköy, İstanbul, Tel: +90 (216) 5698400 EEE Yönetmeliğine Uygundur

Connect with us.    

rockwellautomation.com

expanding **human possibility**[®]

AMERICAS: Rockwell Automation, 1201 South Second Street, Milwaukee, WI 53204-2496 USA, Tel: (1) 414.382.2000, Fax: (1) 414.382.4444

EUROPE/MIDDLE EAST/AFRICA: Rockwell Automation NV, Pegasus Park, De Kleetlaan 12a, 1831 Diegem, Belgium, Tel: (32) 2 663 0600, Fax: (32) 2 663 0640

ASIA PACIFIC: Rockwell Automation, Level 14, Core F, Cyberport 3, 100 Cyberport Road, Hong Kong, Tel: (852) 2887 4788, Fax: (852) 2508 1846

UNITED KINGDOM: Rockwell Automation Ltd. Pitfield, Kiln Farm Milton Keynes, MK11 3DR, United Kingdom, Tel: (44)(1908) 838-800, Fax: (44)(1908) 261-917

Allen-Bradley, ArmorBlock, Guard I/O, CompactBlock, Guardmaster, GuardShield, Lifeline, Minotaur, POINT Guard I/O, Rockwell Automation, and SmartGuard are trademarks of Rockwell Automation, Inc.

EtherNet/IP is a trademark of ODVA, Inc.

Trademarks not belonging to Rockwell Automation are property of their respective companies.

Publication 440E-IN008E-EN-P - September 2022 | Supersedes Publication 440E-IN008D-EN-P - April 2019

Copyright © 2022 Rockwell Automation, Inc. All rights reserved. Printed in the U.S.A.