

LIGHTING BEST PRACTICES SERIES

DAYLIGHT HARVESTING FOR COMMERCIAL BUILDINGS

How to Meet and Exceed California's Building Energy Efficiency Standards

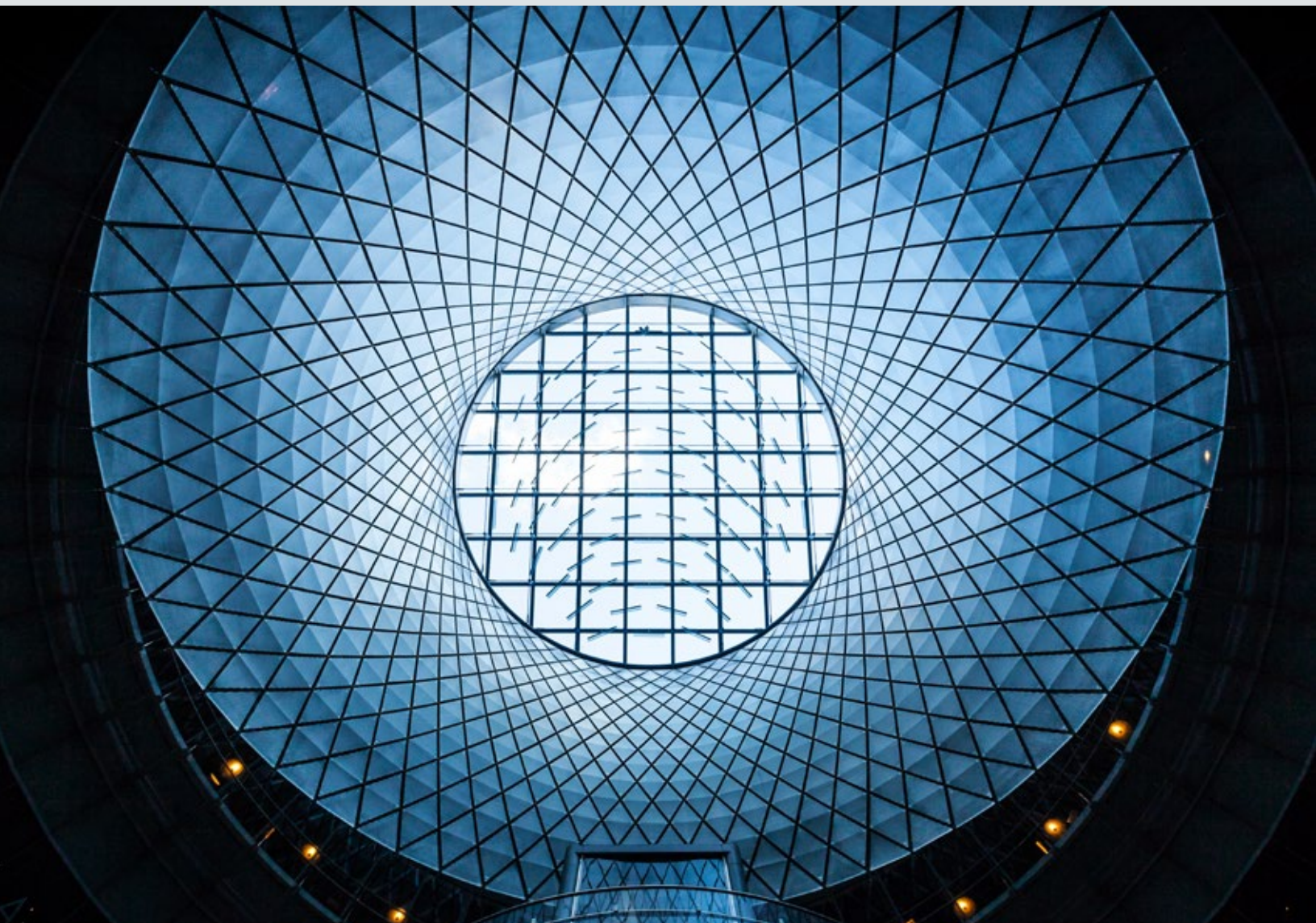

DEVELOPED BY THE CALIFORNIA LIGHTING TECHNOLOGY CENTER, UC DAVIS

© 2018, Regents of the University of California,
Davis campus, California Lighting Technology Center

Guide Prepared by:

California Lighting Technology Center (CLTC)
University of California, Davis
633 Pena Drive
Davis, CA 95618
cltc.ucdavis.edu

Project Partners:

California Energy Commission
Southern California Edison

**Part of the Lighting Best Practices
Publication Series:**

Series includes:

**Nonresidential Lighting and Electrical Power Distribution
Residential Lighting**

Nonresidential: What's New in the 2016 Title 24, Part 6 Code

Residential: What's New in the 2016 Title 24, Part 6 Code

What's New in the Title 20 Code

*FRONT COVER PHOTO:
FULTON CENTER, NEW YORK CITY, NEW YORK
ISTOCK.COM/CMART7327*

Acknowledgements:

The project team acknowledges all contributions to this Guide, including the sponsor (SCE), reviewers (CEC), the authors (CLTC) and UC Davis for their continuing support.

Authors:

Konstantinos Papamichael, PhD
Nicole Graeber Hathaway, Project Manager
Adrian Ang, Graphic Designer
Georgia Mckenzie, Graphic Designer

This program is funded by California utility customers under the auspices of the California Public Utilities Commission and in support of the California Energy Commission. All rights reserved, except that this document may be used, copied, and distributed without modification.

Neither Southern California Edison (SCE) nor any of their employees makes any warranty, express or implied; or assumes any legal liability or responsibility for the accuracy, completeness or usefulness of any data, information, method, product, policy or process disclosed in this document; or represents that its use will not infringe any privately-owned rights including, but not limited to patents, trademarks or copyrights.



CONTENTS

1 | INTRODUCTION

Daylighting Benefits	6
Daylight Harvesting Objectives & Challenges	8
Daylighting Regulations	9
About This Guide	9

2 | CALIFORNIA STANDARDS & REGULATIONS

Building Energy Standards	12
Appliance Efficiency Standards	14

3 | DAYLIGHTING CONSIDERATIONS IN BUILDING DESIGN

Site Selection	18
Building Massing & Fenestration Orientation	27
Glazing & Shading Systems	37
Reflectance of Interior Surfaces	56
Arrangement of Furniture	58
Electric Lighting	59

4 | CONSTRUCTION, COMMISSIONING & ACCEPTANCE TESTING

Construction	76
Commissioning	76
Acceptance Testing	78

5 | IN CLOSING

Daylighting & Energy Efficiency	86
California Green Building Standards	87
Daylight Management	88
Appendix	90



INTRODUCTION

Daylight and fire were the main sources of illumination before the invention of electric lighting. Earth's living organisms have evolved over millions of years under these two main sources of light. Human biology is intimately linked to solar energy, not only for vision, but also for biological functions, especially those that follow the day-night cycle, referred to as circadian rhythms.

Advances in technologies combined with inexpensive electricity have resulted in highly controlled indoor environments, independent of both daily and seasonal variations in outdoor environmental conditions such as light, temperature and humidity. In particular, and in response to the energy crises of the 1970s, access to daylight and outdoor views was greatly reduced, as windows were identified as the most energy inefficient building envelope component, considering heating and cooling loads. Initial energy efficiency measures were focused on reducing window size and, in some extreme cases, eliminating them entirely. Some office and school spaces, for example, were designed to operate without any daylight apertures, resulting in major negative impacts on the well-being of occupants. Today, we have a much better understanding of daylighting benefits including psychological, physiological, biological and energy benefits.



ISTOCK.COM/LIUFUYU

DAYLIGHTING BENEFITS

Daylight vs. Daylighting

Daylight is radiation emitted by the sun, including the radiation scattering effects of the atmosphere. Daylighting is the practice of utilizing daylight in buildings to provide view and illumination.

The most important benefit of daylight apertures, such as windows and skylights, is the connection to the outdoors, which provides information about the time of the day, weather conditions and outdoor activities, all of which are critical for our psychological well-being.

As human vision has evolved under daylight during the day and fire-light during the night, biologically, it is best to use these light sources or light sources that mimic their spectral power distribution. This is the main reason that daylight and incandescent light are considered standards for color fidelity metrics and necessary for maintaining healthy circadian rhythms during daytime and nighttime. The daily variation of daylight intensity and spectral composition is critical to our health, as it adjusts our biological clock and related functions, such as alertness, hormone levels and body temperature (**FIGURE 1**).

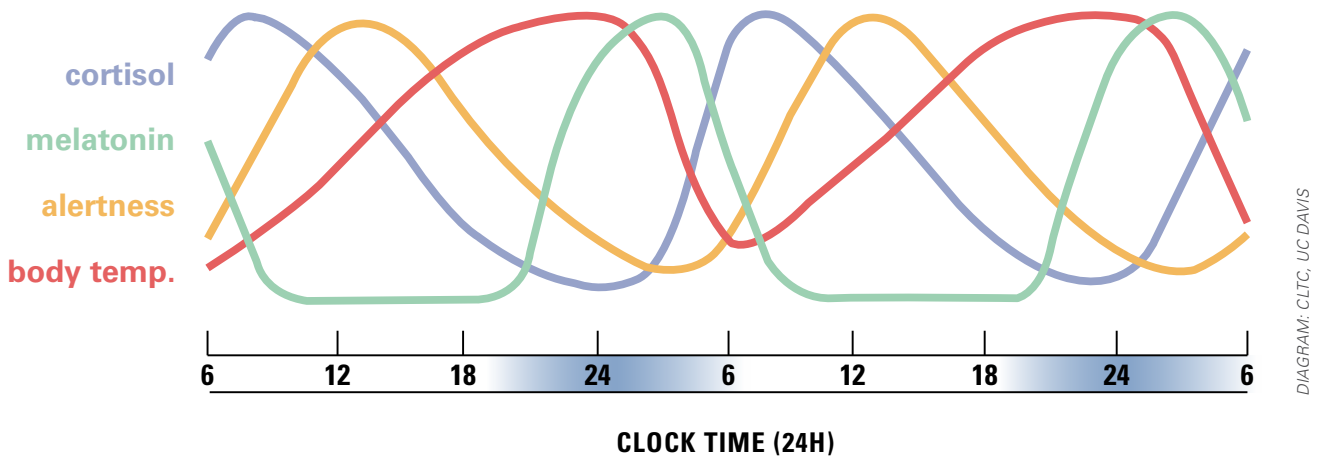

FIGURE 1 Circadian rhythms showing the variation of cortisol, melatonin, alertness and body temperature over two 24-hour periods.

Utilizing daylight for ambient and task lighting can also have significant energy benefits through reduction of electric lighting and associated HVAC loads. Daylighting in commercial buildings can reduce lighting electricity use by as much as 38 percent¹, but it also presents complex challenges. Realization of these energy benefits requires lighting controls that adjust electric lighting based on available daylight. Moreover effects on HVAC loads significantly depend on a building's geographic location and fenestration orientation.

Fenestration

The term "fenestration" refers to all glazed apertures in the building envelope that bring daylight in interior spaces. The term comes from the Latin word "fenestra", which means "window, opening for light".



The IES' Recommended Practice for Daylighting Buildings (RP-5-13)

The Illuminated Engineering Society (IES) developed a guide to provide up-to-date solutions for addressing the challenges of daylighting while maximizing its benefits.

1 Williams, Alison, et al. A meta-analysis of energy savings from lighting controls in commercial buildings. No. LBNL-5095E. Ernest Orlando Lawrence Berkeley National Laboratory, Berkeley, CA (US), 2011.



FIGURE 2 *Glare from direct solar radiation.*



FIGURE 3 *Glare from veiling reflections off a computer monitor, that compete with the brightness of the screen, producing visual discomfort.*

DAYLIGHT HARVESTING OBJECTIVES & CHALLENGES

Daylighting design includes several, often competing, objectives. Considering comfort and energy performance, daylighting design aims at providing view to the outdoors and illumination to allow for reduction of electric lighting without producing glare. During cooling periods, daylighting design aims to do this without producing excessive solar heat gain through direct solar penetration.

Even though daylight is excellent for vision, it can also produce visual discomfort through glare from direct solar radiation (**FIGURE 2**), veiling reflections (**FIGURE 3**), and high contrast of interior and exterior surfaces, or silhouette effect (**FIGURE 4**).

Realizing the energy benefits of daylighting is also challenging, mainly because it requires automated electric lighting and daylight management controls, both of which require sensing environmental conditions, such as daylight levels and glare potential, which are very challenging.

The key challenge for effective daylight harvesting is that it involves decisions made by different decision makers at different stages of the building life-cycle:

1. **City planning**—site selection
2. **Architectural design**—building massing, space dimensions, fenestration location, orientation, size, glazing and exterior shading
3. **Interior design**—geometry and reflectance of interior surfaces, including furniture and its layout, interior shading systems and window treatments
4. **Electric lighting design**—layout of light sources and controls to manage their output based on available daylight
5. **Building Construction**—implementation of design decisions
6. **Building Commissioning**—verification of design decisions and calibration of electric lighting and daylight management control systems
7. **Building Operation**—automated and manual operation of lighting and daylight management systems

Each discipline inherits the decisions made by its predecessors, which can greatly affect decision options and potential to fully realize daylighting benefits.

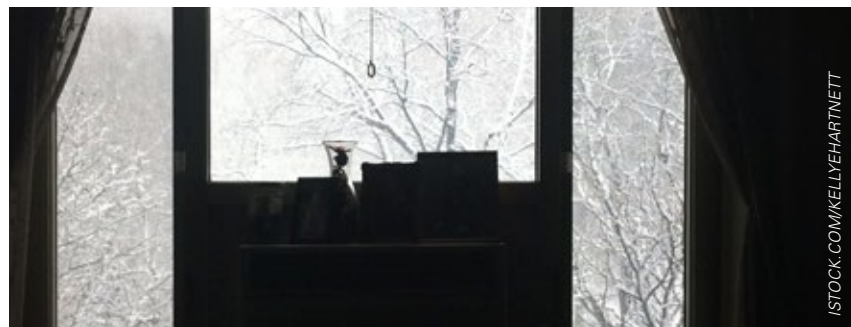

FIGURE 4 *Interior surfaces seen against fenestration may appear as silhouettes due to high contrast between their low brightness and the very bright outdoor surfaces.*

DAYLIGHTING REGULATIONS

To capitalize on the potential for energy efficiency and peak electricity demand reduction through daylight harvesting, California and many other states are adopting increasingly stricter daylight-related requirements as part of their building energy efficiency standards.

In 2008, California set a goal to achieve zero net energy (ZNE) in new commercial buildings by 2030. To reach this objective, new construction projects must combine highly efficient building systems and distributed renewable energy generation to meet 100 percent of their annual energy use.

Meeting building and appliance energy efficiency standards are a good start, but new buildings must go beyond code requirements to meet this bold goal.

ABOUT THIS GUIDE

This daylight harvesting guide includes a description of California's Building Energy Efficiency Standards and Appliance Efficiency Regulations, as well as design guidelines that can help make decisions to meet and exceed the energy standards performance goals. Regulations and design guidelines are organized along the seven building-related disciplines that affect daylight performance.

Some daylight-related building standards address fenestration requirements and some address electric lighting and controls requirements, especially photo-sensor based controls, which adjust the output of the electric lighting system based on available daylight.

Additional savings are possible through use of today's control and communication technologies, which are not yet incorporated into the energy standards or recommended practices. Such emerging approaches are included in this guide to assist readers achieve persistent energy savings while improving comfort and well-being.

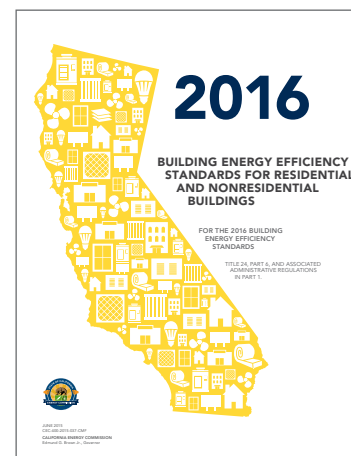
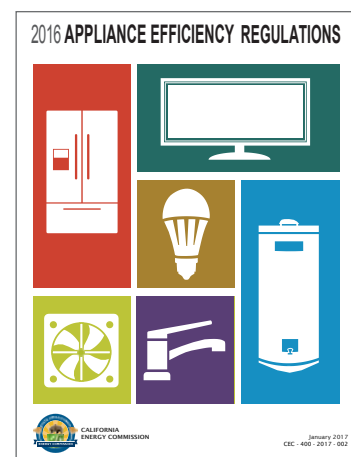

Title 20 and Title 24

California's energy efficiency standards have saved Californians billions in reduced electricity bills since 1977.

To view these standards online, visit www.energy.ca.gov/title20 for Appliance Efficiency Regulations and www.energy.ca.gov/title24 for Building Energy Efficiency Standards.



CALIFORNIA STANDARDS & REGULATIONS

The California Building Energy Efficiency Standards (Energy Standards) define mandatory and prescriptive requirements for new buildings and major retrofits of existing buildings. California Appliance Efficiency Regulations (Appliance Regulations) define performance requirements for building components and systems sold through commercial venues.

Building Energy Efficiency Standards

The Energy Standards regulate many aspects of the built environment, including general construction, building commissioning, and system acceptance testing. The Energy Standards are updated on a three-year cycle. The current Energy Standards were adopted in 2016 and went into effect on January 1, 2017.

Appliance Efficiency Regulations

The Appliance Regulations define the required features of select, new appliances sold in California. Specific to electric lighting controls for daylight harvesting, automatic daylight controls and photo controls are regulated as a 'self-contained lighting control'. The Appliance Regulations dictate the appliance's dimming features, time delays, and other device-specific performance requirements.

ISTOCK.COM/BAONVA
SHERATON EDINBURGH ONE SPA POOL, EDINBURGH, SCOTLAND

BUILDING ENERGY EFFICIENCY STANDARDS

The California Building Energy Efficiency Standards require the following process for all new construction, additions and alterations of existing buildings where a permit is issued.

-  **Step 1: Comply with all mandatory measures**

All nonresidential buildings must be designed and built to comply with the **mandatory measures** of the Building Energy Efficiency Standards using devices that adhere to the Appliance Efficiency Regulations. Mandatory measures are the basic set of requirements that apply to all buildings. For example, electric lighting controls are mandatory measures.
-  **Step 2: Comply with applicable prescriptive or performance measures**

In addition to meeting the mandatory requirements for your project, commercial buildings must adhere to the applicable **prescriptive or performance measures**.

Prescriptive Approach: The prescriptive approach allows builders to comply by using methods known to be efficient. This approach does not require software—rather, it is completed in a checklist format using the Certificates of Compliance.

Performance Approach: The performance approach allows builders freedom of design so long as the building achieves the same overall efficiency as an equivalent building using the prescriptive option. This approach requires using software approved by the Energy Commission and is best suited for use by experienced professionals familiar with the Energy Standards. This method allows for energy trade-offs between building systems. For example, under the performance approach, use of highly efficient lighting can allow for a larger portion of the energy budget to be allocated to heating and cooling loads.
-  **Step 3: Verify Compliance**

After choosing a compliance method, calculate the proposed energy use of the building, or spaces within the building. This value should not exceed the allowed energy budgets specified in the Energy Standards. If the design does not comply, then it will have to be revised.
-  **Step 4: Prepare and Submit Plans**

Once the Energy Standard requirements have been met, the design team compiles the building plans and Certificates of Compliance. Plans and compliance forms are submitted to the appropriate Enforcement Agency, together with a building permit application.
-  **Step 5: Pass Inspection and Receive Permit**

A building department plans examiner must check that the building design satisfies the Energy Standards requirements and that the submitted documentation contains all information to be verified during field inspection. A building permit is issued after plans are reviewed for compliance and approved.

STATE OF CALIFORNIA INDOOR LIGHTING CEC-NRCC-LTI-01-E (Revised 04/16)		CALIFORNIA ENERGY COMMISSION NRCC-LTI-01-E (Page 1 of 6)	
CERTIFICATE OF COMPLIANCE Indoor Lighting		Project Name: _____ Date Prepared: _____	
A. General Information			
Climate Zone:	Conditioned Floor Area:	Unconditioned Floor Area:	
Building Type:	<input type="checkbox"/> Nonresidential	<input type="checkbox"/> High-Rise Residential	<input type="checkbox"/> Hotel/Motel
<input type="checkbox"/> Schools	<input type="checkbox"/> Relocatable Public Schools	<input type="checkbox"/> Conditioned Spaces	<input type="checkbox"/> Unconditioned Spaces
Phase of Construction:	<input type="checkbox"/> New Construction	<input type="checkbox"/> Addition	<input type="checkbox"/> Alteration
Method of Compliance:	<input type="checkbox"/> Complete Building	<input type="checkbox"/> Area Category	<input type="checkbox"/> Tailored
Project Address: _____			
B. Lighting Compliance Documents (select yes for each document included) <input checked="" type="checkbox"/>			
<small>For detailed instructions on the use of this and all Energy Efficiency Standards compliance documents, refer to the Nonresidential Manual published by the California Energy Commission.</small>			
YES	NO	COMP. DOC.	TITLE
<input type="radio"/>	<input type="radio"/>	NRCC-LTI-01-E	Certificate of Compliance. All Pages required on plans for all submittals.
<input type="radio"/>	<input type="radio"/>	NRCC-LTI-02-E	Lighting Controls, Certificate of Compliance, and PAF Calculation. All Pages required on plans for all submittals.
<input type="radio"/>	<input type="radio"/>	NRCC-LTI-03-E	Indoor Lighting Power Allowance
<input type="radio"/>	<input type="radio"/>	NRCC-LTI-04-E	Tailored Method Worksheets
<input type="radio"/>	<input type="radio"/>	NRCC-LTI-05-E	Line Voltage Track Lighting Worksheets
<input type="radio"/>	<input type="radio"/>	NRCC-LTI-06-E	Indoor Lighting Existing Conditions

Nonresidential Lighting Compliance Forms

As part of the California Building Energy Efficiency Standards compliance process, the design team must prepare and submit documents to verify compliance (see Step 4).

The Energy Commission has made these compliance documents, or examples of these documents, available at www.energy.ca.gov/title24/2016standards.

Step 6: Complete Construction

The installation team must follow the approved plans and specifications during construction. Certificates of installation must be completed and signed by licensed individuals to certify that the lighting installed for the project corresponds with the lighting proposed on the Certificates of Compliance.

Step 7: Commission Building Systems

 After construction is complete, the contractor and/or the design team must properly commission, or bring into working condition, the building and its systems. They must also advise the building owners and operators of their responsibilities regarding compliance with Energy Standards. They must provide information and training to the building owner on how to maintain and operate the building systems.

Step 8: Pass Inspection by an Acceptance Test Technician

The Energy Standards require that Acceptance Test Technicians review and test newly installed building systems to ensure the controls and connected loads operate as required by the Energy Standards.

Step 9: Pass Final Inspection

The building department field inspector(s) must verify that the building construction follows the plans and specifications that were approved when the building permit was issued. Once final inspection is complete, the certificate of occupancy is issued.

Step 10: Provide documentation to building owners

Upon occupancy, the building owner must receive copies of the energy compliance documents from the installation team, including Certificates of Acceptance, along with instructions for operation and maintenance.

APPLIANCE EFFICIENCY REGULATIONS

Automatic Daylight Controls

Automatic Daylight Control is defined by the Appliance Efficiency Regulations as a “self-contained lighting control device that automatically adjusts lighting levels by using one or more photosensors to detect changes in daylight illumination and then changing the electric lighting level in response to the changes in daylight”.

Photo Controls

Photo Control is defined by the Appliance Efficiency Regulations as an “automatic daylight control device that automatically turns lights on and off, or automatically adjusts lighting levels, in response to the amount of daylight that is available. A photo control may also be one component of a field assembled lighting system, the component having the capability to provide a signal proportional to the amount of daylight to a lighting control system for the purpose of dimming the electric lights”.

The California Appliance Efficiency Regulations define the minimum required performance of select new appliances sold in California. Specific to electric lighting controls for daylight harvesting, automatic daylight controls and photo controls are regulated, as defined by the California Energy Commission in the sidebar and the requirements below.

Automatic Daylight Controls Requirements

- Reduce the power consumption of the controlled lighting in response to measured daylight
- Comply with the Dimmer Control requirements of the **Appliance Regulations** if the daylighting control is capable of directly dimming lamps
- Automatically return to its most recent time delay settings within 60 minutes after being put in calibration mode
- Have a set point control that easily distinguishes settings in increments of ten percent of full scale or maximum adjustment
- Have a light sensor that has a linear response within five percent accuracy over the range of illuminance measured by the light sensor
- Have a light sensor that is physically separated from where the calibration adjustments are made, or is capable of being calibrated in a manner that the person initiating the calibration is remote from the sensor during calibration to avoid influencing calibration accuracy

Photo Controls Requirements

- Photo controls shall not have a mechanical device that permits disabling of the control

Modernized Appliance Efficiency Database System (MAEDBS)

This online database of products certified by the Energy Commission has a Quick Search function allowing users to search by product type, brand, or model.

Visit the Appliance Efficiency Database at appliances.energy.ca.gov.

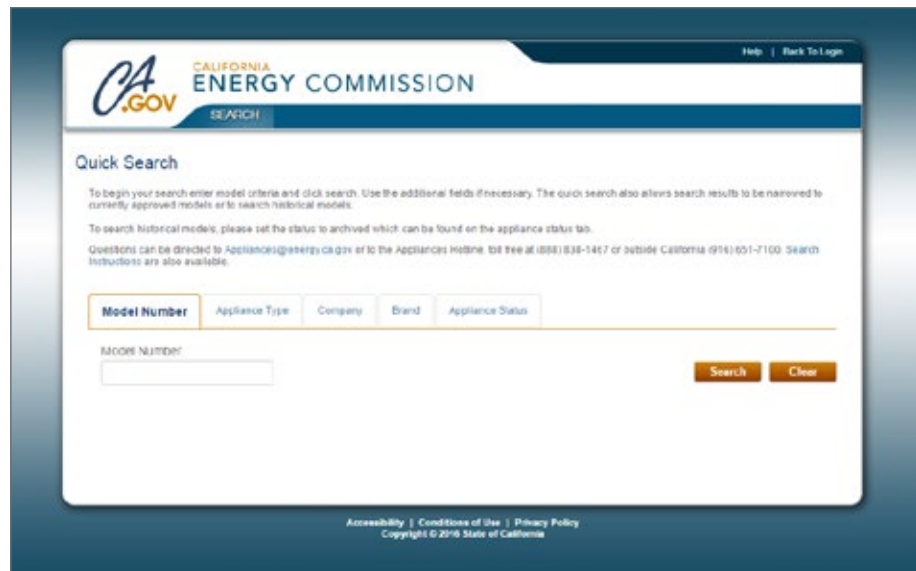



3
PARKING
LEVEL 2
YORK BLVD
JAMES ST
LEVEL 1
FOOD FARM

WALKWAY
ELEVATORS

WALKWAY
ELEVATOR

ISTOCK.COM/BENEDEK
HAMILTON CITY CENTRE MALL, HAMILTON, ONTARIO, CANADA



DAYLIGHTING CONSIDERATIONS IN BUILDING DESIGN

Daylight harvesting considerations span the whole building life cycle, from the selection of the building site, through architectural and interior/lighting design, to building construction, commissioning and operation. Every decision affecting daylighting becomes context for the decisions to follow. Design decisions become context for construction and the latter becomes context for commissioning and operation.

The main daylighting design objectives are to 1) provide a view to the outdoors, 2) provide enough daylight to support all or part of the required illumination for the tasks performed in the space during daytime, while 3) avoiding visual or thermal discomfort and 4) minimizing electric lighting and HVAC requirements.

This chapter addresses city planning, architectural, interior and lighting design decisions.

CITY PLANNING & ARCHITECTURAL DESIGN



ISTOCK.COM/DELL640

INTERIOR & LIGHTING DESIGN



ISTOCK.COM/PETINOVIS

ISTOCK.COM/EILEEN_10
THE OCULUS, NEW YORK CITY, NEW YORK

CITY PLANNING & ARCHITECTURAL DESIGN

Design decisions related to daylighting include site selection, building massing and orientation of spaces, fenestration design in terms of daylight apertures and associated glazing and shading systems.

SITE SELECTION

GUIDELINES

Site selection is very important for daylight performance and has a strong effect on what may be possible in terms of the architectural design that follows. It defines the context for design decisions related to daylight harvesting. Site selection dictates sun paths, climatic conditions, external obstructions and also California Building Energy Efficiency Standards requirements.

THE NATURE OF DAYLIGHT

Sunlight is electromagnetic radiation with a spectrum composed of about 5 percent Ultra Violet (UV) radiation (below 400 nm), about 43 percent visible radiation (from 400 nm to 700 nm) and about 55 percent Infrared radiation (IR) (above 700 nm). The spectral power distribution of sunlight is altered significantly by the atmosphere, as different gases and particles interact with different wavelengths of the solar radiation (FIGURE 5). As the solar radiation enters the atmosphere, it encounters air molecules that scatter the wavelengths that correspond to blue light, making the sky appear blue. When sunlight is scattered by cloud water droplets, all of the solar spectrum is scattered, making clouds appear white and turning grey as the water droplets become larger (FIGURE 6).

The spectral power distribution of the visible spectrum arriving on the Earth surface changes dramatically, depending on the position of the sun in the sky and the atmospheric conditions.

ENERGY STANDARDS

Primary responsibility for compliance and enforcement rests with the local enforcement agency, typically associated with a city or county government. A building permit must be obtained from the local jurisdiction before construction of:

- A non-residential building
- Significant alterations to existing lighting systems
- An outdoor lighting system
- Signage
- Additions to existing buildings

STANDARDS

CONTINUED ON PAGE 19

Spectral Distribution of Sunlight and Molecular Absorption

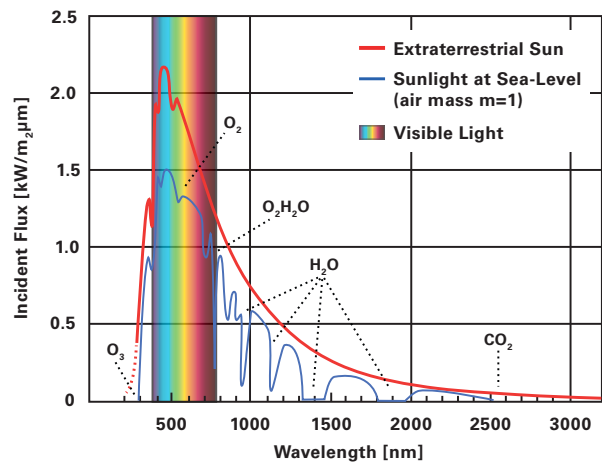

REPRODUCED BY CLTC, UC DAVIS
ORIG. SOURCE: CLEAR — CLEAR LOW ENERGY ARCHITECTURE

FIGURE 5 The spectral power distribution of daylight above the atmosphere and at sea level.



DIAGRAMS: REPRODUCED BY CLTC, UC DAVIS
ORIG. SOURCE: UNKNOWN

FIGURE 6 The air molecules of the atmosphere scatter the blue part of the solar spectrum, making the sky appear blue (left). Water droplets scatter the whole solar spectrum, making clouds appear white and turn grey as water droplets become larger and reduce the transmitted sunlight (right).

The IR portion of solar radiation comprises more than half of the solar energy at sea level. While not visible, IR radiation is felt as heat and has a strong impact on HVAC loads, with potential to reduce heating loads and increase cooling loads. The key challenge in daylighting is balancing light and heat to prevent glare and reduce HVAC loads.

When solar radiation is incident on a surface, a fraction of it is reflected and the rest is absorbed, elevating the surface temperature and then re-emitted in the *long-wavelength IR* (thermal or far IR), which has much longer wavelengths than the *short-wavelength IR* (near IR) (**FIGURE 7**). The difference between near and far IR is important, because the first can be transmitted through the atmosphere and through glass, while the latter cannot. This is the cause of the “greenhouse” effect trapping of solar energy transmitted through glass or the atmosphere, causing “local” and global warming, respectively.

The core compliance process is broken into two steps:

1. Meet all mandatory requirements, which define the following:
 - Required controls that must be installed
 - Minimum lighting system functionality
 - Device certification requirements defined by the Energy Commission via the Appliance Efficiency Standards
2. Utilize the prescriptive or performance approach to compliance to establish the minimum level of performance for the building.

ENERGY STANDARDS

CONTINUED ON PAGE 21

Reach Codes

State law allows local jurisdictions to adopt building energy efficiency standards that are more stringent than Title 24, Part 6, through an approval process with the California Energy Commission. These local ordinances, sometimes called “reach codes,” are listed on the Energy Commission website: www.energy.ca.gov/title24/2016standards/ordinances.

SUN PATHS

The sun is the main source of daylight. Its apparent movement through the sky, referred to as “sun paths” is critical for architectural and interior design decisions (FIGURE 8).

Sun paths vary by geographic latitude, which is the angular distance from the equator. Sun paths do not vary significantly across California latitudes (FIGURE 9).

Customized Sun Path Diagrams

The sun paths used in this guide were created by the University of Oregon’s Solar Radiation Monitoring Laboratory. Customized sun path diagrams can be produced by a free online tool developed by the University of Oregon’s Solar Radiation Monitoring Laboratory: solardat.uoregon.edu/PolarSunChartProgram.php.

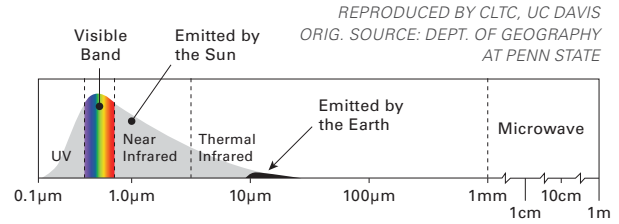
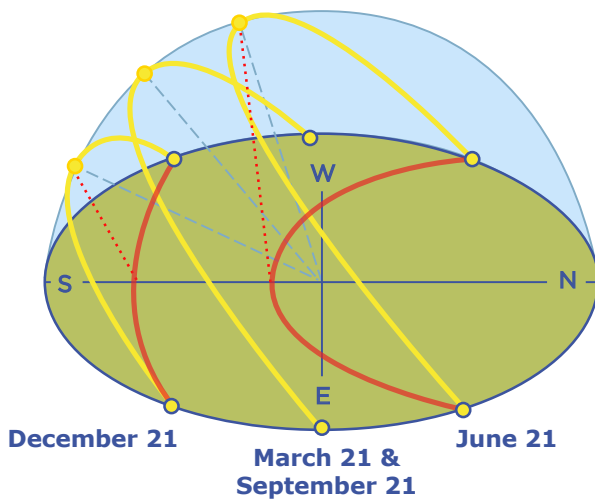

FIGURE 7 The spectral power distribution of solar radiation and the distinction between near and far IR radiation. The lower the temperature of an object, the longer the wave-length of the IR radiation it emits. The wavelengths of radiation emitted by the earth are more than an order of magnitude larger than the wavelengths emitted by the sun.

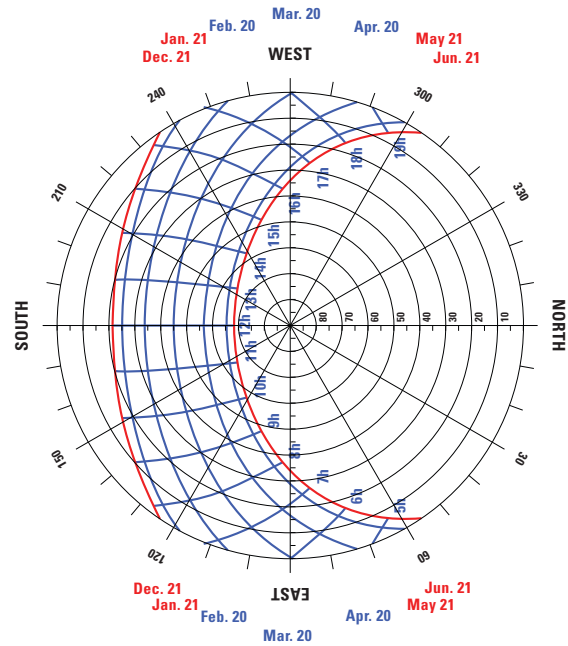

FIGURE 8 LEFT: Schematic drawing of sun paths for mid-north-latitude locations. Sunrise and sunset orientations vary significantly throughout the year, along with the length of the sun paths and their highest position on the sky. RIGHT: Sun paths diagram showing the projection of sun paths on a horizontal surface. Sun path diagrams are most useful in daylighting design, as they show the sun positions for the whole year and allow for quick and easy evaluation of effects on different surfaces, such as building facades with different orientations.

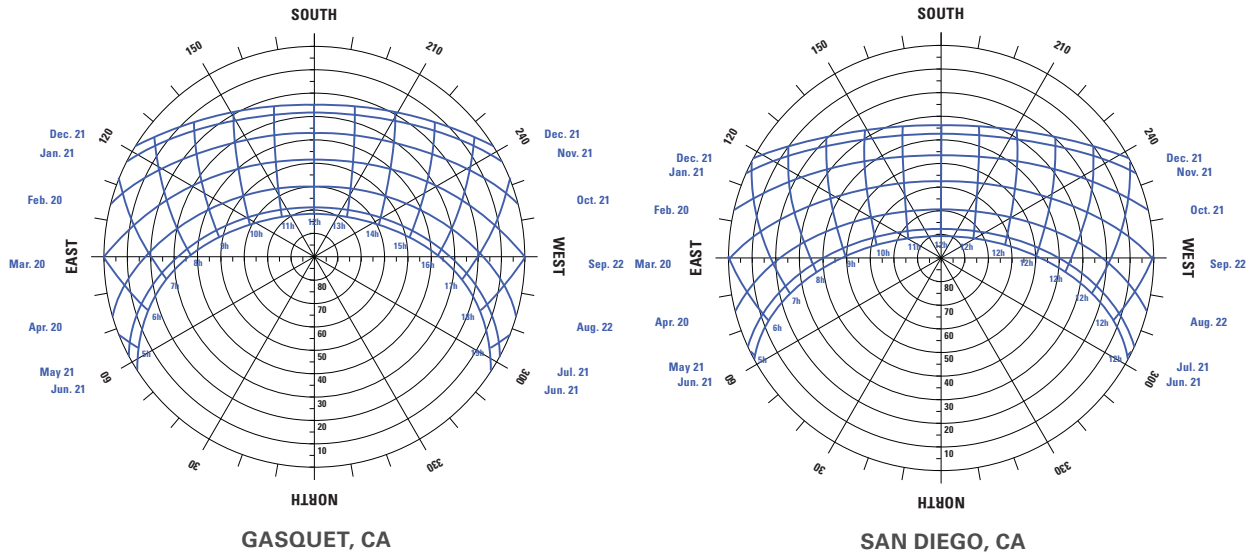

DIAGRAM: KONSTANTINOS PAMAMICHAEL
ORIG. SOURCE: CI UNIVERSITY OF OREGON SRML

FIGURE 9 Sun paths for locations at the northern (Gasquet) and southern (San Diego) California borders.

CLIMATIC CONDITIONS

Locations with the same latitude have identical sun paths, but may have very different climatic conditions. Climatic conditions have a strong impact on sky conditions and also on HVAC loads, both of which greatly affect daylight performance and are very important in daylighting design decisions. Review of climatic conditions is the first daylight consideration in architectural design. The most important climate characteristics for daylighting are: 1) sky conditions (FIGURE 10) and 2) outdoor daylight illuminance on horizontal and vertical surfaces from both direct solar radiation from the sun and diffuse radiation from the sky (FIGURE 11).

The main source for climate data is the National Oceanic and Atmospheric Administration (NOAA) (ncdc.noaa.gov/cdo-web/). Climate data are being collected for a large number of cities in the United States by the National Climatic Data Center (NCDC), NOAA. Climate data have been used for a long time in the hourly simulation of the energy performance of buildings, and have also been introduced in annual daylighting simulations for the computation of annual daylight performance metrics, such as the Daylight Autonomy and the Spatial Daylight Autonomy.

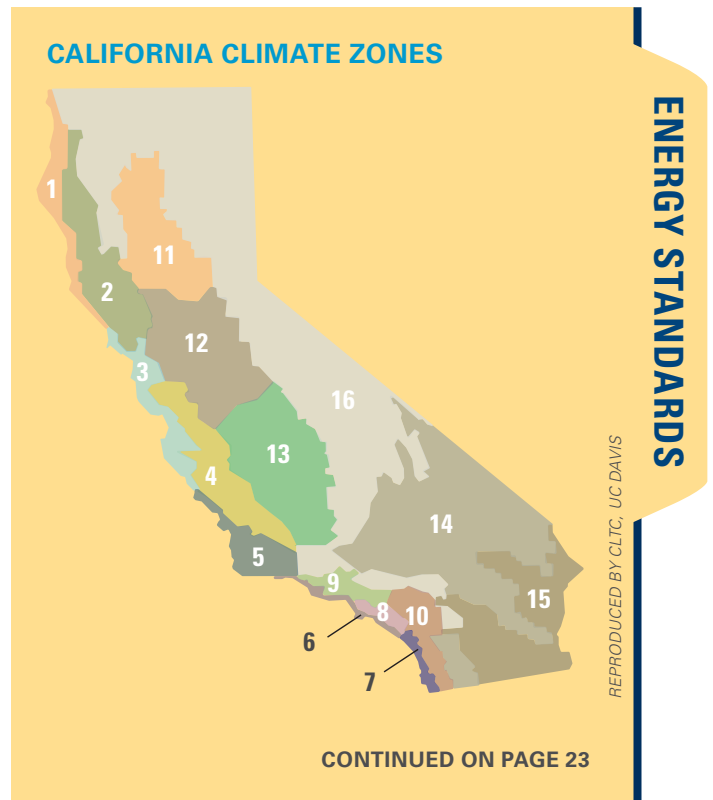

Daylight Autonomy and Spatial Daylight Autonomy

Daylight autonomy refers to the percent of occupied time that daylight alone meets design work place illuminance at a particular point in space. Spatial daylight autonomy refers to the percent of space that meets or exceeds a specific daylight autonomy.

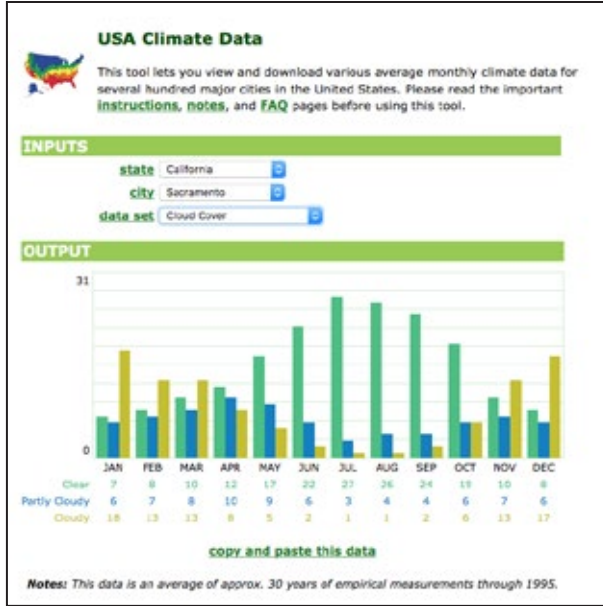

SACRAMENTO, CA

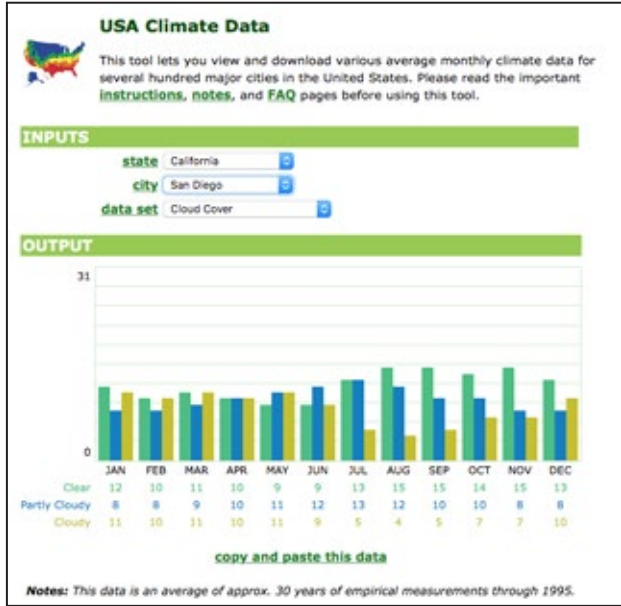

SAN DIEGO, CA

FIGURE 10 Cloud cover data for Sacramento and San Diego by month, from data collected over 30 years of empirical measurements through 1995.

DIAGRAM: SUSTAINABLE BY DESIGN

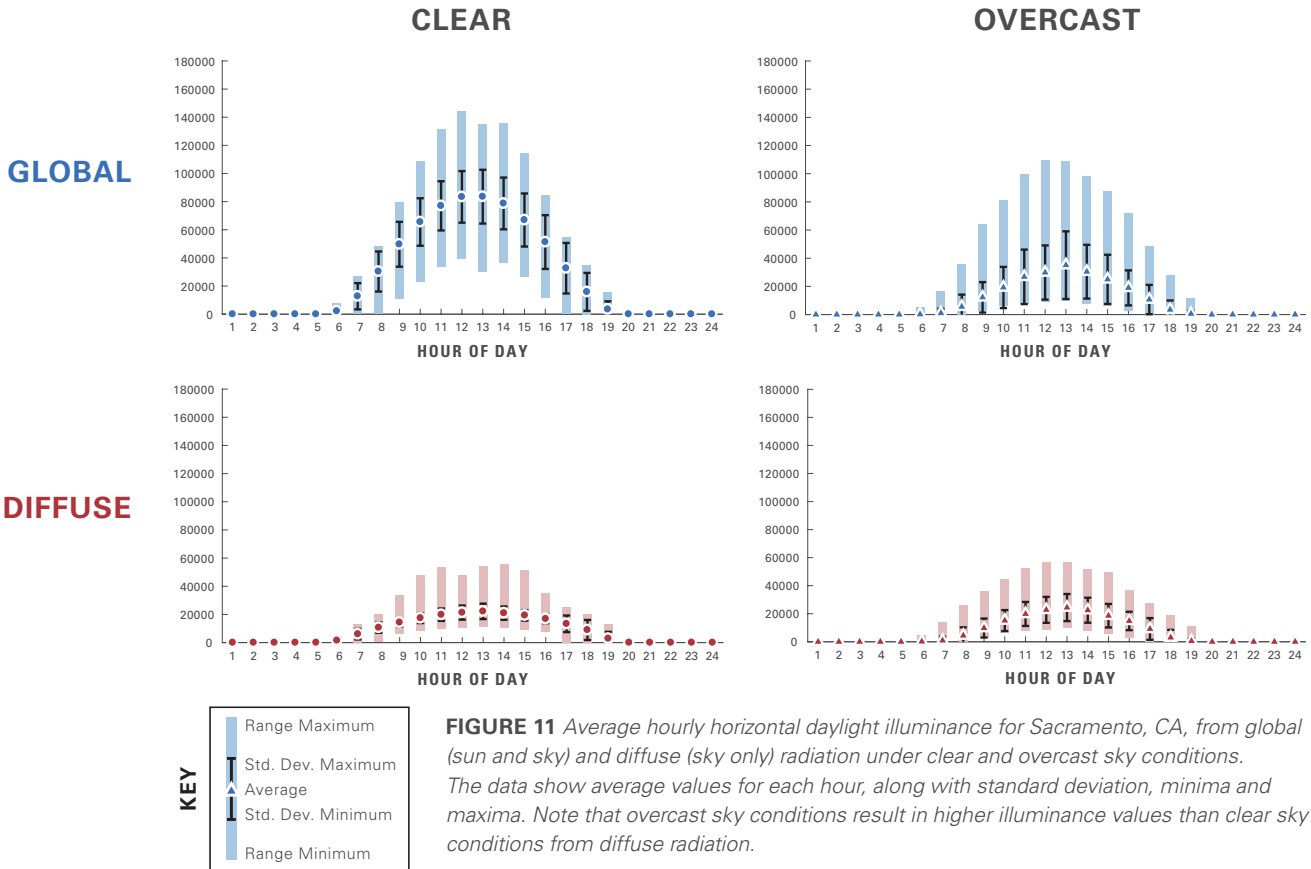

FIGURE 11 Average hourly horizontal daylight illuminance for Sacramento, CA, from global (sun and sky) and diffuse (sky only) radiation under clear and overcast sky conditions. The data show average values for each hour, along with standard deviation, minima and maxima. Note that overcast sky conditions result in higher illuminance values than clear sky conditions from diffuse radiation.

DIAGRAM: ANOTHAI THANACHAREONKIT, CLTC, UC DAVIS

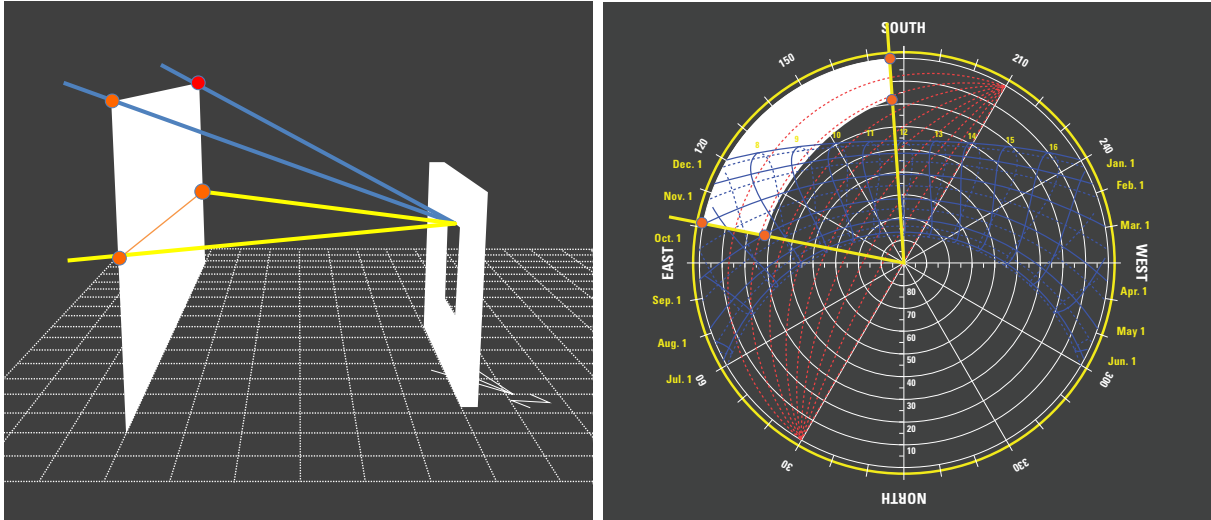

DIAGRAM: KONSTANTINOS PAPAMICHAEL
ORIG. SOURCE: "SOLAR TOOL" SOFTWARE BY ANDREW MARSH

FIGURE 12 Determination of the shadow mask of an external obstruction for the mid-point of the window head. The blue lines are the sun paths for Sacramento, California. The white area is the shadow mask for the center point of the window head, as shown in the left drawing of the figure. The sun is blocked by the external obstruction for the times that the sun paths overlap with the full shadow mask of the external obstruction. The red lines are profile angles in 10-degree increments from 0 (horizon) to 90 (sky zenith), which define the projection of straight lines, e.g., the top edge of the external obstruction, which has a profile angle of about 21 degrees from the horizon.

EXTERNAL OBSTRUCTIONS

Understanding the effects of the size and location of external obstructions, such as neighboring buildings and landscaping, is also critical for daylight design. External obstructions may block direct sunlight from reaching daylight apertures, or reflect direct sunlight towards them.

SHADOW MASKS

The shading effect of external obstructions can be effectively determined and visualized by drawing *shadow masks* of external obstructions on sun-path diagrams. Shadow masks define the area of the sky that is blocked by an obstruction when viewed from a particular point, usually the middle point of window heads (**FIGURE 12**).

Daylit Zones

The Energy Standards define how to determine the size and location of your Daylit Zones. Visit **page 63** of this guide or the **Nonresidential Lighting and Electrical Power Distribution Guide** for details.

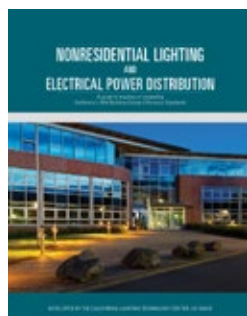

In Climate Zones 2 through 15, conditioned and unconditioned enclosed spaces that are greater than 5,000 ft² and that are directly under a roof with ceiling heights greater than 15 feet, must meet the following requirements:

- A combined total of at least 75 percent of the floor area, as determined using building floor plans, shall be within one or more of the following:
 - Primary Sidelit Daylit Zone in accordance with **Section 130.1(d) 1B**, or
 - The total floor area in the space within a horizontal distance of 0.7 times the average ceiling height from the edge of rough opening of skylights.
- All Skylit Daylit Zones and Primary Sidelit Daylit Zones shall be shown on building plans.
- General lighting in daylit zones shall be controlled in accordance with **Section 130.1(d)**.
- The total skylight area is at least 3 percent of the total floor area in the space within a horizontal distance of 0.7 times the

ENERGY STANDARDS

CONTINUED ON PAGE 25

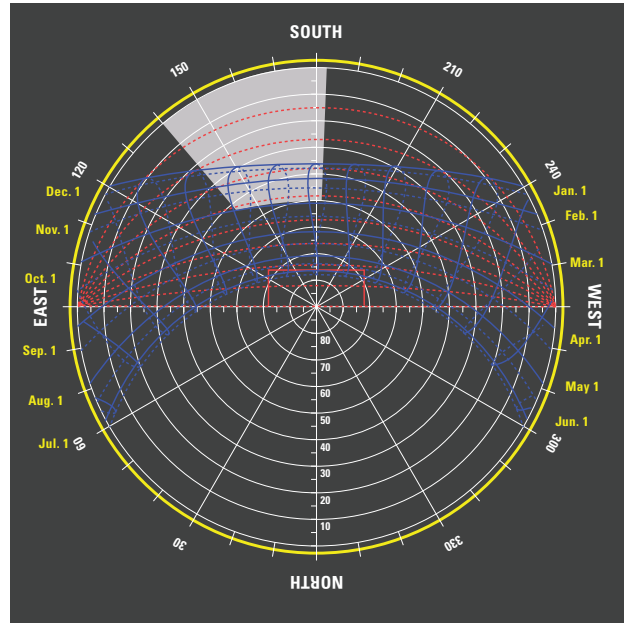
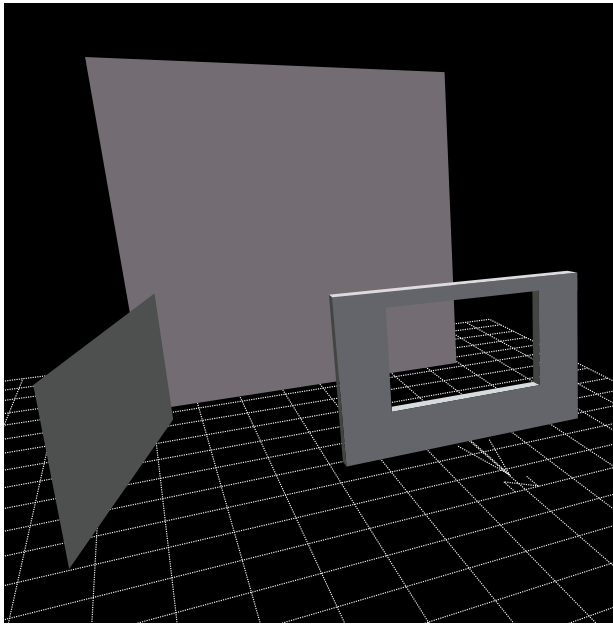

DIAGRAM: KONSTANTINOS PAPAMICHAEL
 ORIG. SOURCE: "SOLAR TOOL" SOFTWARE BY ANDREW MARSH

FIGURE 13 A full shadow mask for a daylight aperture, determined as the intersection of individual shadow masks for the left and right edges of the window head. Only the taller obstruction produces a full shadow mask, as the shorter cannot block the sky for the higher aperture areas.

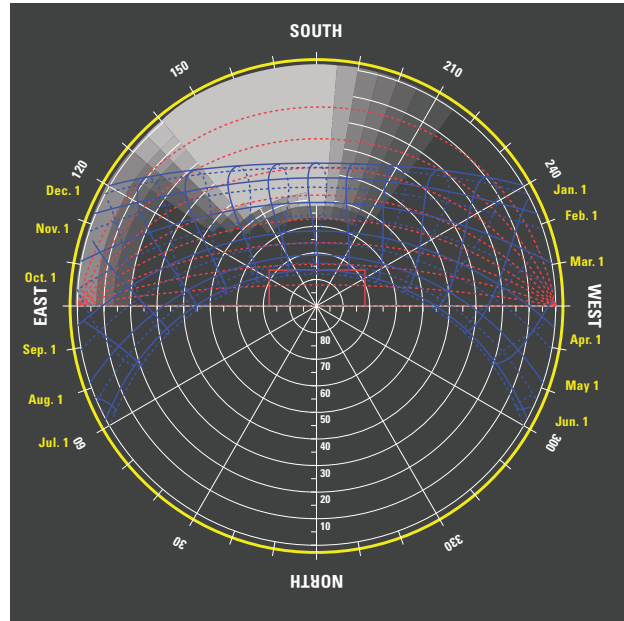
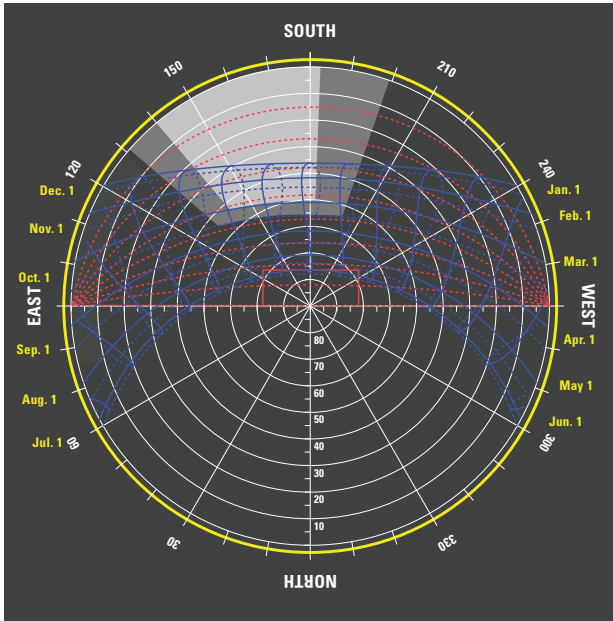

DIAGRAM: KONSTANTINOS PAPAMICHAEL
 ORIG. SOURCE: "SOLAR TOOL" SOFTWARE BY ANDREW MARSH

FIGURE 14 Full and center-point shadow masks for a daylight aperture.

FIGURE 15 Percent shadow mask showing the percent of the daylight aperture that is being blocked.

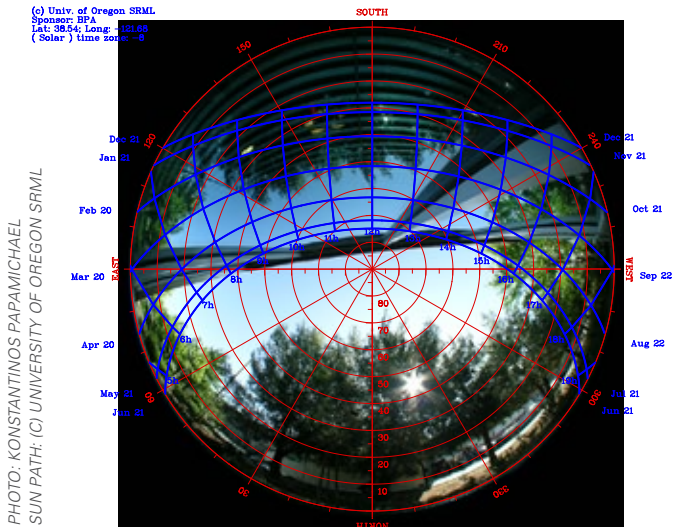

FIGURE 16 Shadow mask produced with a fish-eye photograph of the sky from a point close to the mid-point of a window sill, with superimposed sun path diagrams that show which times of the year the sun will be reaching the mid-point of the window sill, i.e., the camera location.

Full shadow masks show the area of the sky that is blocked for all points of a fenestration aperture. Full shadow masks are determined by the intersection of the shadow masks of key fenestration points (**FIGURE 13**). *Center Point shadow masks* are for the center point of the window (**FIGURE 14**). *Percent shadow masks* show the percent of the window area that is blocked by a sky element and are usually determined through specialized software applications (**FIGURE 15**).

Shadow masks can be determined manually using architectural drawings, through various CAD tools, and also through fish-eye photographs facing the sky. Superimposing sun path diagrams with shadow masks using the same hemispherical projection show the times of the year that the external obstructions would be blocking the sun for a particular point (**FIGURE 16**).

average ceiling height from the edge of rough opening of skylights; or the product of the total skylight area and the average skylight visible transmittance is no less than 1.5 percent of the total floor area in the space within a horizontal distance of 0.7 times the average ceiling height from the edge of rough opening of skylights.

- All skylights shall have a glazing material or diffuser that has a measured haze value greater than 90 percent, tested according to **ASTM D1003** (notwithstanding its scope) or another test method approved by the Commission.
- Skylights for conditioned and unconditioned spaces shall have an area-weighted average Visible Transmittance (VT) no less than the applicable value specified in **Section 140.3(a) 6D**.

EXCEPTIONS: SECTION 140.3(C)

The following spaces are exceptions of the requirements in **Section 140.3(c)**:

- Auditoriums, churches, movie theaters, museums, and refrigerated warehouses
- In buildings with unfinished interiors, future enclosed spaces for which there are plans to have:
 - A floor area of less than or equal to 5,000 square feet; or
 - Ceiling heights of less than or equal to 15 feet. This exception shall not be used for S-1 or S-2 (storage), or for F-1 or F-2 (factory) occupancies.
- Enclosed spaces having a designed general lighting system with a lighting power density less than 0.5 watts per square foot
- Enclosed spaces where it is documented that permanent architectural features of the building, existing structures or natural objects block direct beam sunlight on at least half of the roof over the enclosed space for more than 1500 daytime hours per year between 8 A.M. and 4 P.M.

SketchUp Plugins

Shadow masks can be determined using CAD tools, like the SketchUp software program. Additional plug-ins for SketchUp designed to help you meet and exceed California's Building Energy Standards are available at extensions.sketchup.com.



PHOTO: (CARI) LAURA LEAN, CITY AM (BUILDING) AFP
20 FENCHURCH STREET, LONDON, UK

FIGURE 17 External obstructions can redirect sunlight through reflection, reaching areas that otherwise would be in the shadow. The photograph shows the heat effects of reflected sunlight being concentrated through reflection off a high reflectance curved façade. The concentrated reflected sunlight deformed a car mirror.

REFLECTED SUNLIGHT

External obstructions can reflect sunlight towards daylight apertures. Depending on the magnitude and type of the surface reflectance of external obstructions, the reflected sunlight can be very intense. Reflected sunlight from surfaces with high specular reflectance, such as the façade of glass buildings, has the same, and sometimes worse, effect as direct sunlight (**FIGURE 17**).



ISTOCK.COM/MONKEYBUSINESSIMAGES
SOUTHAMPTON SOLENT UNIVERSITY, SOUTHAMPTON, UK

BUILDING MASSING & FENESTRATION ORIENTATION

GUIDELINES

Building massing and arrangement of spaces are the most important daylighting decisions, as they define the total building area of the building that will be adjacent to daylight apertures, and also the orientation of the different spaces that will be benefiting from daylighting (**FIGURE 19 & FIGURE 20**). Building massing also defines shadow effects of the building shape on its own fenestration. Orientation of building spaces initiates the consideration of architectural shading systems, such as external horizontal and/or vertical elements for different façade orientations and individual spaces.

FENESTRATION ORIENTATION

Fenestration orientation is very important because it defines the incident direct solar radiation through the year and the related need for exterior and/or interior shading devices. By observing the sun paths across California, it becomes evident that different fenestration orientations have very different relationships to the sun paths.

NORTH ORIENTATION

North-facing fenestration in California is exposed to direct sunlight only during the early morning and late evening hours of the summer (**FIGURE 21**).

ENERGY STANDARDS

The Energy Standards are accompanied by a Compliance Manual published by the California Energy Commission. The Compliance Manual contains design guidance and provides examples for specific requirements included in the Energy Standards. Portions of this section include information contained in the Compliance Manual to fully explain the Energy Standards requirements.

The Energy Standards differentiate windows from skylights based on glazing slope, with skylights having a glazing slope less than 60 degrees from horizontal and windows having a glazing slope of 60 degrees or greater from horizontal (**FIGURE 18**).

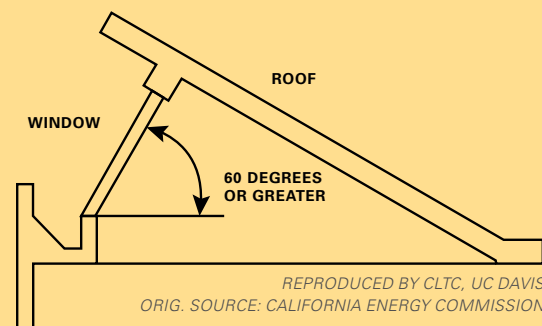

FIGURE 18 Schematic drawing showing the Energy Standards definition for windows.

CONTINUED ON PAGE 28

ENERGY STANDARDS

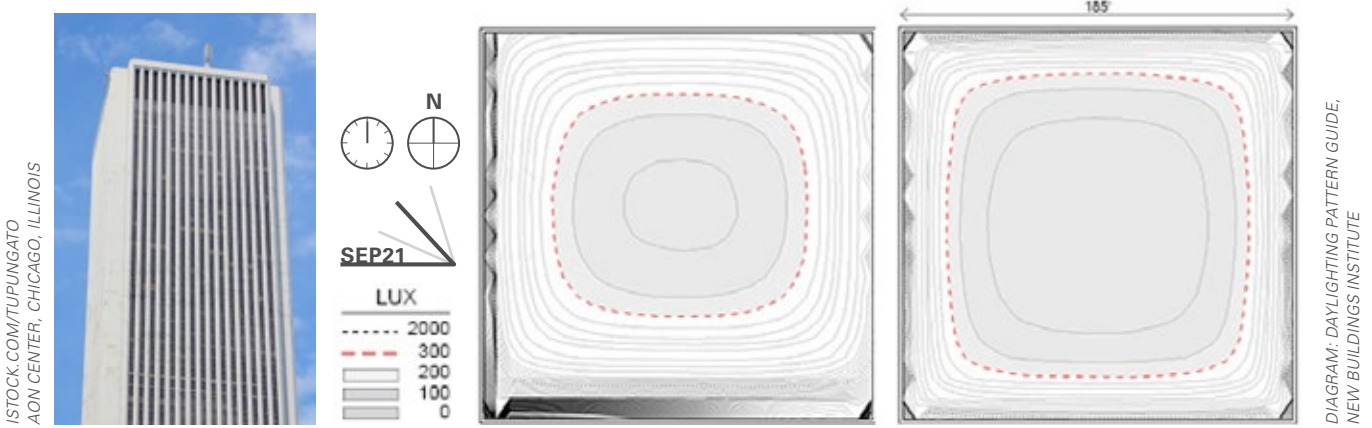

FIGURE 19 Rectangular foot-print building with large core area, resulting in 55% and 25% of floor space being adequately illuminated by daylight under sunny and overcast conditions on September 21 at noon, respectively.

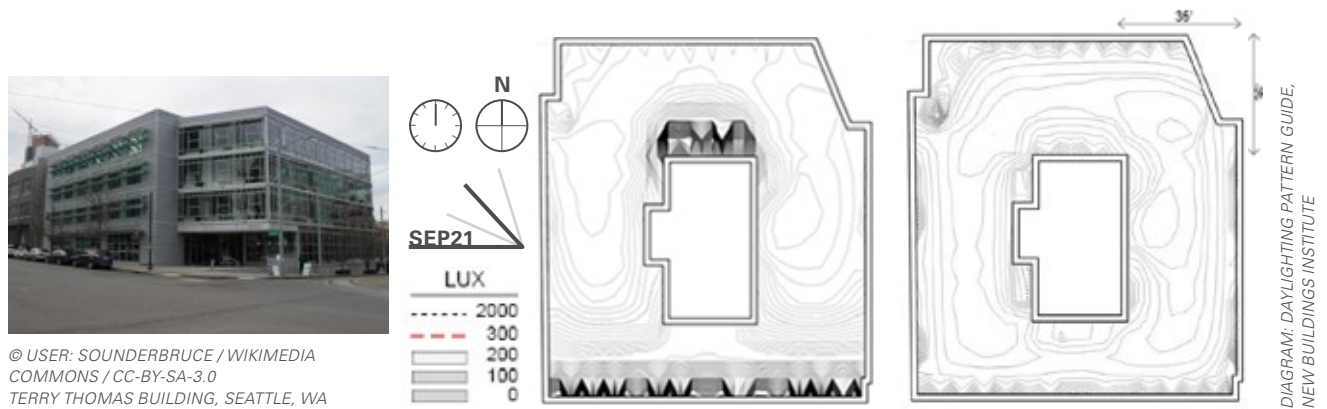

FIGURE 20 Rectangular foot-print building with atrium, resulting in 100% and 90% of floor space being adequately illuminated by daylight under sunny and overcast conditions on September 21 at noon, respectively.

North-facing apertures can be large and need minimal to no shading from direct sun penetration. North apertures provide consistent daylight illumination in interior spaces for most of the year, with diffuse daylight from the sky, making them most suitable for work environments.

SOUTH ORIENTATION

South-facing fenestration is exposed to direct sunlight throughout the year (FIGURE 22). This is true for the whole day during the period from the fall equinox through the spring equinox. During the period from the spring equinox through the fall equinox, the exposure to the sun is reduced to late morning and early afternoon hours, with minimal exposure during the summer solstice. All sun positions and exposure durations are centered around solar noon.

In the prescriptive path to compliance for the building envelope, the total window area may not exceed 40 percent of the gross wall area encompassing all conditioned spaces for the building. Additionally, the west-facing window area may not exceed 40 percent of the west-facing gross wall area.

The maximum allowed window area is determined by whichever is greater between:

$$A_M = 6 \times L \text{ OR } A_M = 0.4 \times A_W$$

- A_M = Maximum allowed window area for a building,
- L = Length of the display perimeter, where a display perimeter is the length of an exterior wall that immediately abuts a public sidewalk, such as retail display window,
- A_W = Gross exterior wall area.

CONTINUED ON PAGE 30

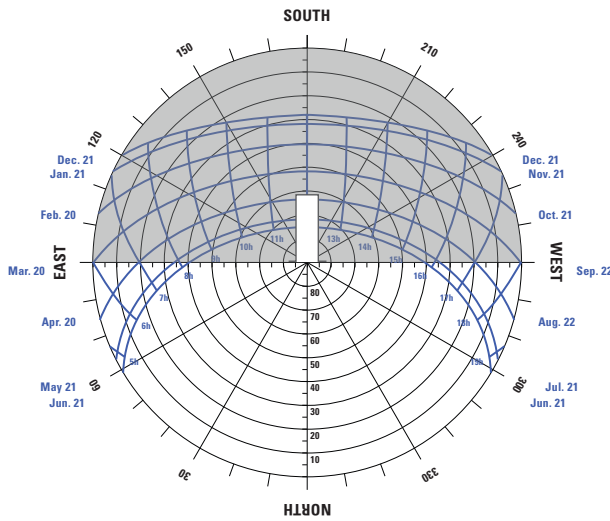

FIGURE 21 North-facing apertures in California will be affected by direct solar radiation only during the early morning and late evening of the summer season.

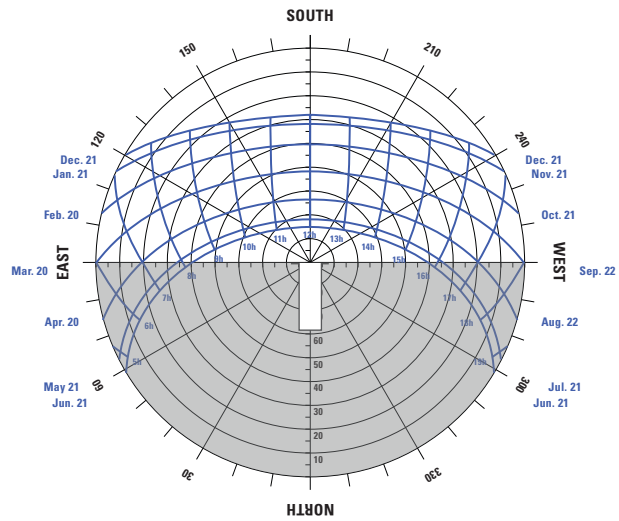

FIGURE 22 South-facing apertures in California are exposed to direct sun throughout the day during the fall-winter-spring periods. The winter sun directions are from very low solar altitude angles and can produce significant flare. The sun exposure during the summer occurs only during the middle of the day and from very high solar altitude angles, resulting in high incident angles on vertical apertures.

DIAGRAM: KONSTANTINOS PAPAMICHAEL
ORIG. SOURCE: (C) UNIVERSITY OF OREGON SRML

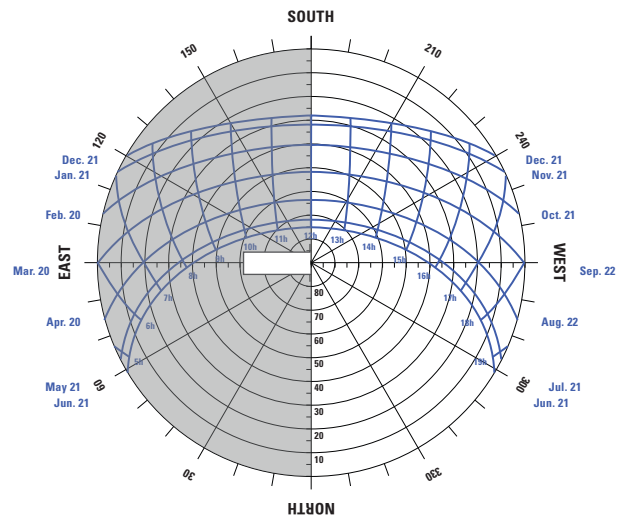
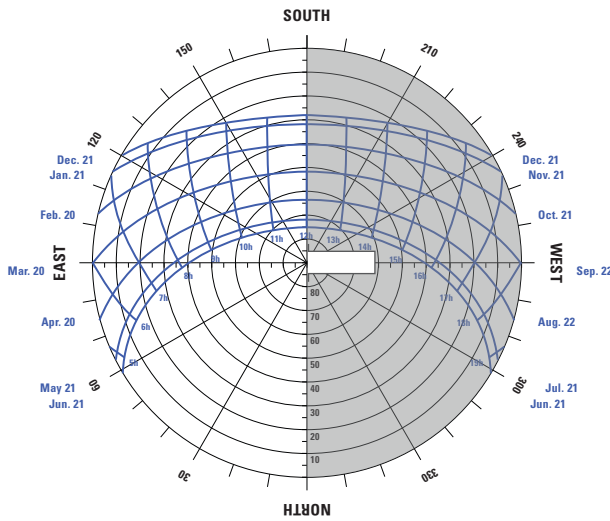

FIGURE 23 East- and West-facing apertures in California will be exposed to direct solar radiation only during the morning and afternoon hours, respectively, throughout the year. Direct solar radiation is incident at very small incident angles for both orientations during the beginning and the end of the day, respectively.

DIAGRAM: KONSTANTINOS PAPAMICHAEL
ORIG. SOURCE: (C) UNIVERSITY OF OREGON SRML

The incident angle of the sun on a vertical fenestration during solar noon (true south orientation) is much larger during the summer, with its maximum on summer solstice, and much lower during the winter, with its minimum on winter solstice.

EAST & WEST ORIENTATIONS

East and west fenestration orientations are symmetrical in terms of sun paths, with East orientation being exposed to direct sunlight during the morning hours and the west orientation being exposed during afternoon hours (FIGURE 23). While the sun paths are the same, the West orientation is considered worst in terms of thermal comfort and solar heat gain, because during the afternoon hours thermal (and cooling) loads reach their peak during the day.

As a practical matter, window area is generally taken from the rough opening dimensions.

WINDOW ORIENTATION

Windows at any orientation within 45 degrees of true north, east, south, or west will be assigned to that orientation. FIGURE 24 demonstrates how window surface orientations are determined and what to do if the window surface is oriented exactly at 45 degrees off a cardinal orientation. For example, an east-facing window surface cannot face exactly northeast, but it can face exactly southeast. If the window surface were facing exactly northeast, it would be considered north-facing.

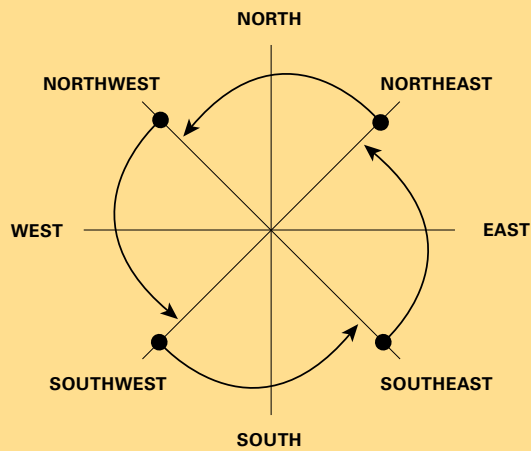

FIGURE 24 Determination of a window surface orientation if the surface is oriented exactly 45 degrees off a cardinal orientation.

REPRODUCED BY CLTC, UC DAVIS
ORIG. SOURCE: CALIFORNIA ENERGY COMMISSION



PHOTO: KONSTANTINOS PAPAMICHAEL
SACRAMENTO INTERNATIONAL AIRPORT



PHOTO: KONSTANTINOS PAPAMICHAEL
BARCELONA INTERNATIONAL AIRPORT

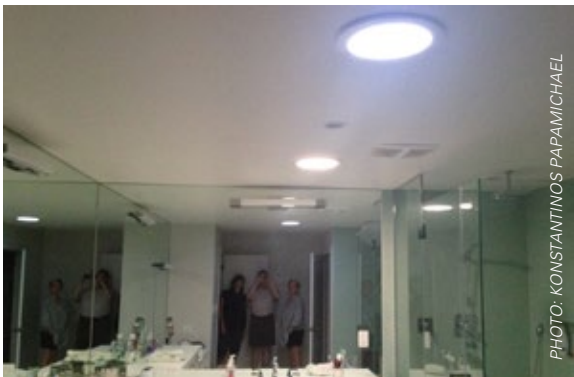

PHOTO: KONSTANTINOS PAPAMICHAEL



PHOTO: KONSTANTINOS PAPAMICHAEL
CALPERS BUILDING, SACRAMENTO, CA

FIGURE 25 Photographs of different daylighting systems, showing clerestory and vertical windows (top left), skylights and clerestory windows (top right), tubular daylighting devices bringing sunlight through the ceiling (bottom left) and an atrium, providing daylight to the space below and the adjacent spaces on each floor (bottom right).

BUILDING FENESTRATION

The building fenestration can include a variety of daylight apertures, bringing daylight from the roof through skylights, atria and tubular daylighting devices, and from side walls through windows and clerestories (**FIGURE 25**).

SKYLIGHTS

Single-story buildings and top floors of multistory buildings can be illuminated by daylight very effectively and efficiently using skylights (**FIGURE 26**). The primary function of skylights is to introduce daylight in architectural spaces. They can also provide a view of the sky if the glazing material has specular transmittance. However, skylights usually incorporate glazing with diffuse transmittance, to avoid glare from direct solar penetration. Diffuse glazing materials prevent view to the outdoors, but provide some degree of connection in terms of sky conditions and time of day.



PHOTO: KONSTANTINOS PAPAMICHAEL
BARCELONA INTERNATIONAL AIRPORT

FIGURE 26 Linear skylights with sloped glazing.

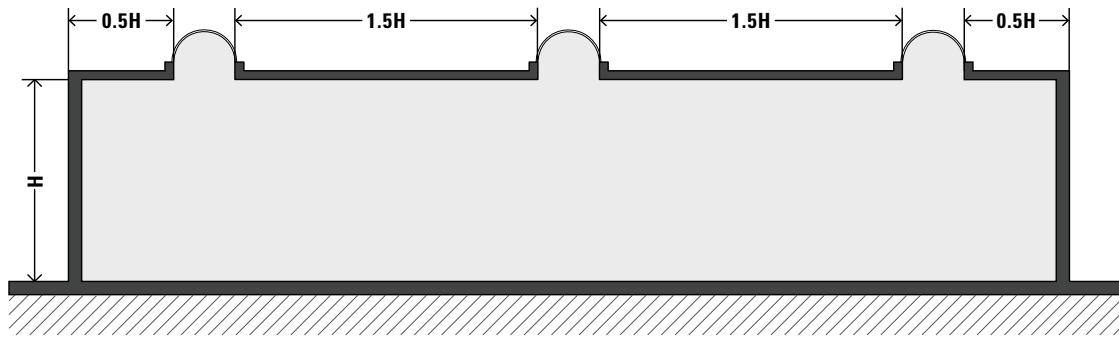

DIAGRAM: MATTHEW TANTERI

FIGURE 27 Schematic drawing showing rule-of-thumb spacing for skylight applications.

To balance electric lighting savings through daylight harvesting and associated thermal loads (convective/conductive heat loss/gain and solar heat gain) the skylight area should be between three and eight percent of the floor area. This percent varies by application, depending on various factors, such as location and glazing transmittance. For uniform daylight distribution, skylights should be spaced at distances of about 1.5 times the ceiling height of the space. Skylights at the perimeter of the space should be at a distance of about one-half ceiling height from the perimeter (**FIGURE 27**).

Skylights in commercial applications are usually installed on horizontal roofs, but can also be installed on sloped roofs. Horizontal skylights are exposed to direct solar radiation throughout clear sky days. When installed on sloped roofs, the times and intensity of incident solar radiation varies by latitude and orientation. As sun paths are very similar across California, orientation becomes the primary factor that affects performance in terms of exposure to direct solar radiation for sloped skylights.

ATRIA

Atria are equivalent of closed courtyards in buildings with more than one story, covered with glazing material for protection from the elements. In addition to providing daylight in the closed courtyard, atria also provide daylight to interior spaces with windows and clerestories facing the atrium (**FIGURE 28**).



PHOTO: KONSTANTINOS PAPAMICHAEL
RADDISSON BLU HOTEL, AMSTERDAM, NETHERLANDS

FIGURE 28 Atrium in multi-story building providing daylight to the yard below and the spaces adjacent to the atrium.

TUBULAR DAYLIGHTING DEVICES (TDD)

Tubular daylighting devices (TDDs) bring daylight to interior spaces through ceiling apertures. They use metallic tubes with very high reflectance materials that reach the building roof and specialized optics to capture daylight from the sun and the sky. The metallic tubes can include corner elements that allow TDDs to be installed around obstacles between the ceiling and the roof (FIGURE 29).

WINDOWS

Windows are the most common daylight apertures, with potential to illuminate interior spaces at depths of two window-head heights. While the main function of skylights is to introduce daylight into architectural spaces, the main function of windows is to provide view and connection to the outdoors.

The daylight distribution through windows is very uneven, with comparatively very high levels next to the window that drop significantly as you move away from the window (FIGURE 30).



FIGURE 29 Tubular daylighting devices bringing daylighting through the roof.

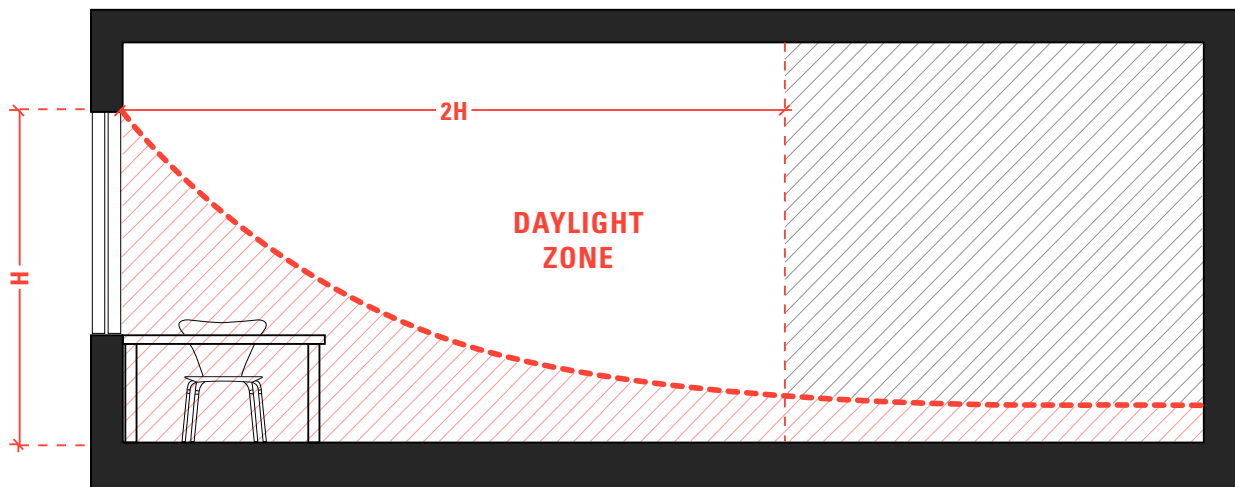
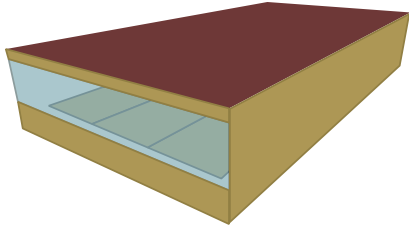
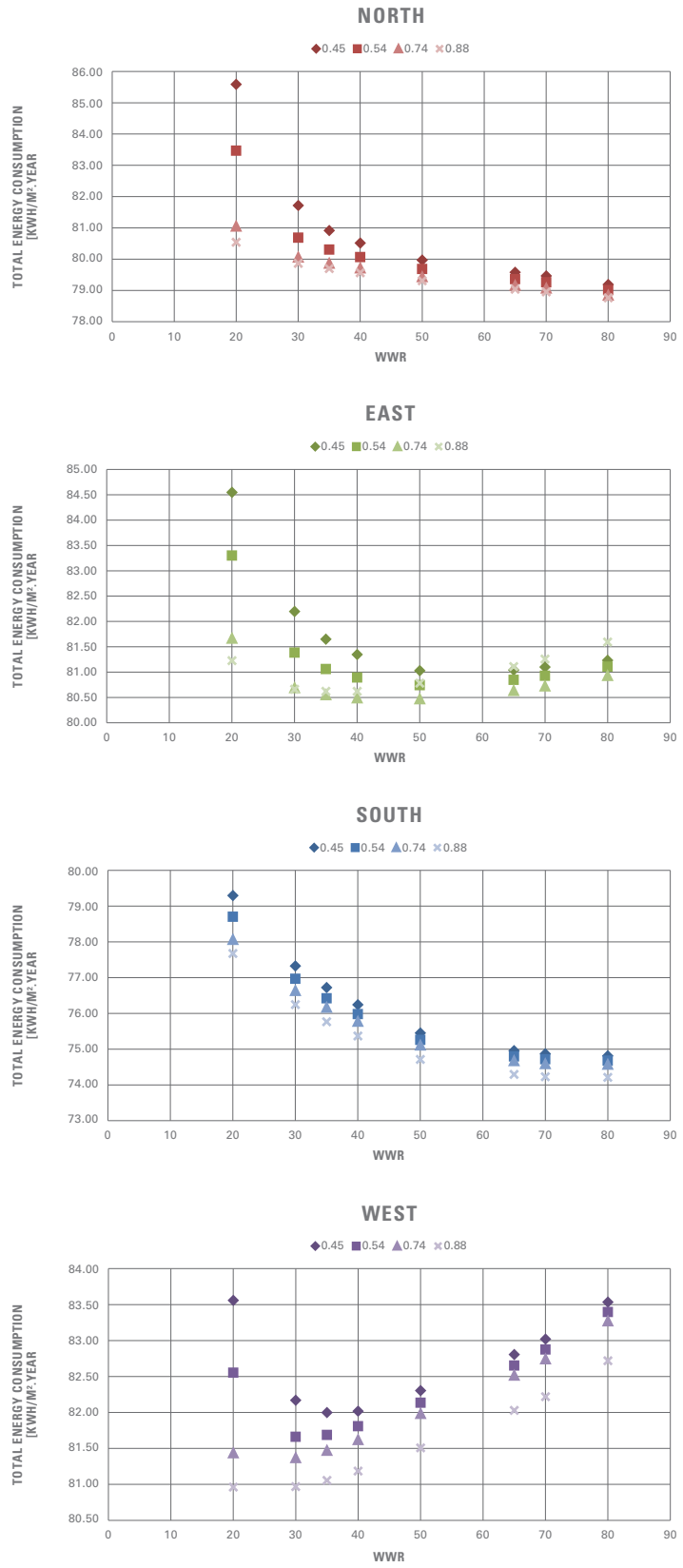

FIGURE 30 Schematic diagram showing the daylight work-plane illuminance levels across the depth of a space with a window. The daylight levels close to the window are very high and drop significantly with distance from the window. Daylight through windows can provide daylight illumination at distances of up to two window head-heights from the window.



**TOTAL ENERGY CONSUMPTION
-SACRAMENTO-**

FIGURE 31 Simulation results for total energy consumption as a function of window-to-wall-ratio for different glass transmittance values in Sacramento, CA.



SIMULATION & PLOTS: RAPHAELA DE FONSECA,
CLTC, UC DAVIS

To balance electric lighting savings through daylight harvesting and associated thermal loads, window area should usually be between about 30 percent and 50 percent of the window wall area. This percent varies by application, depending on various factors such as location, window orientation, glazing transmittance and space proportions (FIGURE 31).

CLERESTORIES

Clerestories, also known as daylight monitors, are identical to windows, but bring daylight in spaces from top areas of walls and also from walls that are above roofs.

Clerestories introduce daylight deeper into spaces than windows, as they occupy areas of walls higher than windows. They can also provide connection to the outdoors in the way that skylights do by providing a view of the sky if the glazing material has specular

transmittance. As the primary objective of clerestories is daylight penetration rather than view, they often incorporate glazing with diffuse transmittance or shading devices to avoid glare from direct solar penetration.

Clerestories are often used instead of skylights, when they are mounted in walls above roofs, such as in saw-tooth roof applications. Their performance, however, is much more affected by orientation, as they bring light from the side walls of spaces.

For the best daylight uniformity, clerestories in saw-tooth roof applications should be spaced at distances of about 2.5 times the ceiling height of the space. (FIGURE 32).

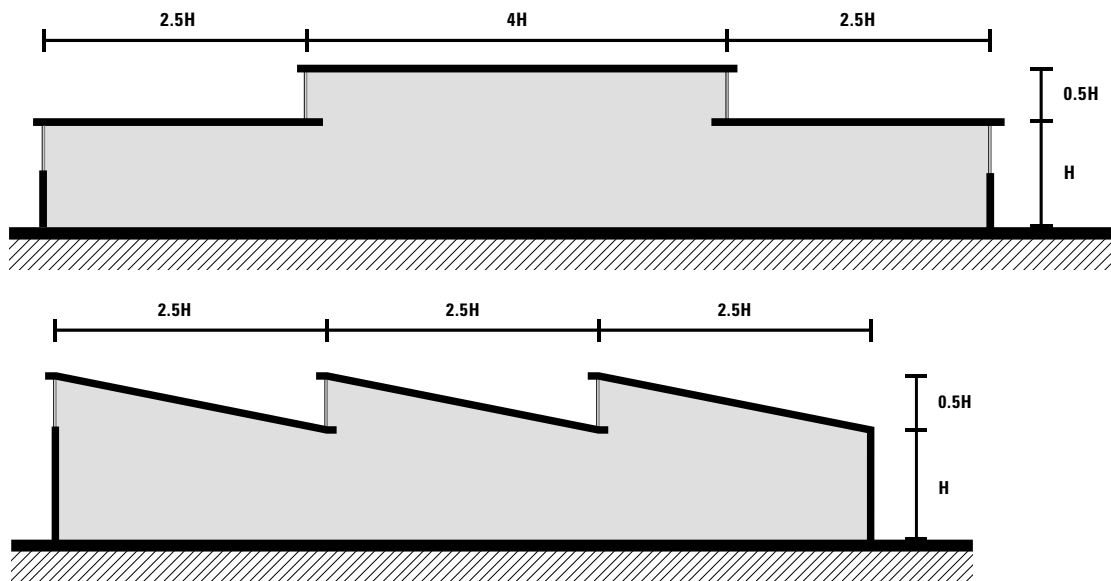

DIAGRAMS: MATTHEW TANTERI

FIGURE 32 Schematic drawing showing rule-of-thumb for spacing clerestories.

FENESTRATION DESIGN

The main objective in fenestration design is to maximize as many benefits—illumination, view and circadian health—and minimize negative performance effects such as glare and increased HVAC loads, especially for cooling. The main challenge is to thoughtfully consider the annual variation of daylight levels, sun paths, and cloud conditions at the building location, and also the outdoor terrain, neighboring buildings and vegetation for each daylight aperture.

Fenestration design starts with architectural design decisions in terms of arranging the spaces of the building and the daylight apertures of each space. For more information on these design decisions, please read the Architectural Design section of these guidelines. Effective decisions on placement, size and shape of daylight apertures require simultaneous consideration of glazing and shading decisions, which is the focus of this section.

Fenestration design decisions are greatly affected by the local sun paths, which, along with the orientation of daylight apertures, dictate the incident angle (FIGURE 33 and FIGURE 34) of direct solar radiation through the year. The smaller the incident angle, the more challenging the shading from direct solar radiation, as blocking small incident angles significantly compromises view.

An emerging strategy for window design is separation of the daylight aperture in two separate apertures, one below human height, intended for view and the other above human height, intended for providing daylight to reduce electric lighting and HVAC requirements. Each of the two daylight apertures is treated differently in terms of glazing and shading and they are usually separated by an exterior and/or interior light shelf, which provides shade from high solar altitudes for the lower view aperture while reflecting direct and diffuse sunlight and from the upper daylight aperture towards the ceiling for deeper daylight penetration.

Natural Ventilation & Cooling

Building fenestration can include venting mechanisms to support natural ventilation and cooling, which can be very effective in California, when the outdoor temperature during night time is much lower than the temperature during day time.

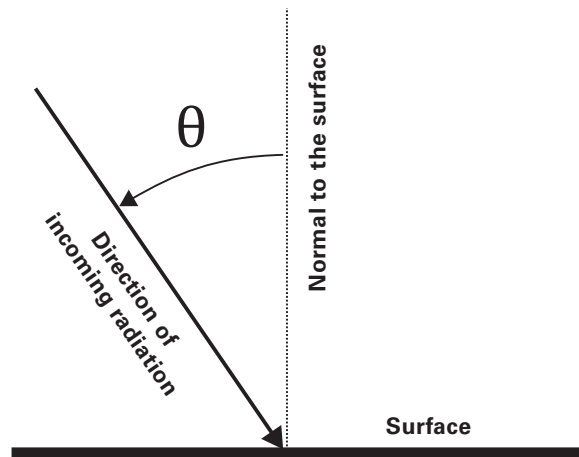

DIAGRAM: KONSTANTINOS PAPAMICHAEL

FIGURE 33 The incident angle of radiation on a surface is the angle of the direction of incoming radiation from the normal direction to the surface. It varies from 0 (coincident to the normal direction) to 90 degrees.

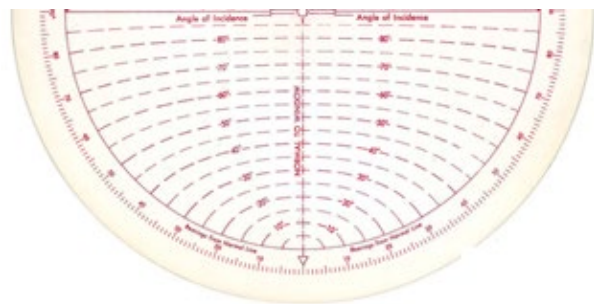

PHOTO: BRS PROTRACTORS

FIGURE 34 Incident angle iso-contours for a vertical surface. Usually used as overlay on sun path diagrams to quickly estimate solar incident angles on vertical surfaces.



GLAZING & SHADING SYSTEMS

GUIDELINES

Glazing and shading systems are most important for effective daylighting in terms of comfort and energy performance. Daylight apertures affect multiple performance aspects beyond illumination and energy, such as view, privacy and safety. Glazing and shading systems come in a very wide range of options that address different combinations of such performance aspects.

Glass vs. Glazing

Glass is an inorganic transparent material composed of silica (sand), soda (sodium carbonate), lime (calcium carbonate) and small quantities of alumina, boric, or magnesia oxides. Glazing is the combination of glass and/or plastic panes in a window, door, or skylight.

Manufactured vs. Site-built vs. Field-fabricated Fenestration Products

Manufactured fenestration is a product constructed of materials which are factory cut or otherwise factory formed with the specific intention of being used to fabricate a fenestration product.

Site-built fenestration is a product designed to be field-glazed or field assembled using specific factory cut or otherwise factory formed framing and glazing units, that are manufactured with the intention of being assembled at the construction site. These include storefront systems, curtain walls, and atrium roof systems.

Field-fabricated fenestration is a product whose frame is made at the construction site of standard dimensional lumber or other materials that were not previously cut, or otherwise formed with the specific intention of being used to fabricate a fenestration product. Field fabricated does not include site-built fenestration.

ENERGY STANDARDS

The Building Energy Efficiency Standards include mandatory requirements for the building envelope and lighting systems that are directly related to daylight harvesting.

BUILDING ENVELOPE

There are three types of fenestration products: manufactured, field-fabricated and site-built. All fenestration products must meet specific requirements for key solar, optical and thermal performance parameters and be certified by the Commission. For manufactured and site-built products, air leakage, U-factor, solar heat gain coefficient (SHGC), visible transmittance (VT), labeling, and acceptance criteria are specified by the Standards in **Section 110.6(a)**. Field-fabricated products must meet **Section 110.6(b)**, which includes criteria for U-factor, solar heat gain coefficient (SHGC), visible transmittance (VT), and caulking, sealing and weatherstripping. There are no air infiltration, labeling, or certification (other than NRCC-ENV-05) requirements for field-fabricated products.

CONTINUED ON PAGE 38

KEY PROPERTIES OF GLAZING AND SHADING SYSTEMS

The most important properties of glazing and shading systems relevant to comfort and energy efficiency are their thermal and solar-optical properties, especially the U-value (U-factor), the Visible Light Transmittance (VLT), and the Solar Heat Gain Coefficient (SHGC).

U-FACTOR

The U-factor is a metric of the rate of heat transfer through the glazing or shading system due to temperature differences on either side of the fenestration assembly, expressed in terms of power per area per temperature difference, $W/m^2 \cdot K$ in the metric system and $BTU/hr \cdot ^\circ F \cdot ft^2$ in the imperial system.

U-factors are used to characterize glazing and shading systems, as well their combination and the entire fenestration assembly, including frames. The lower the U-factor, the greater the resistance to heat flow.

U-factors are normally given for NFRC/ASHRAE winter conditions of 0° F (18° C) outdoor temperature, 70° F (21° C) indoor temperature, 15 mph wind, and no solar load.

SOLAR-OPTICAL PROPERTIES

The solar-optical properties of glazing and shading systems describe their interaction with the solar and visible parts of the electromagnetic radiation, respectively.

Incident radiation on glazing and shading systems is partly reflected, partly absorbed, and partly transmitted, depending on their material and thickness. These three fractions of the incident radiation are the transmittance (T),

Spectral Solar-Optical Properties

Solar-optical properties represent the aggregated effect of spectral properties, i.e., the transmittance, reflectance, and absorptance across the solar and visible parts of the spectrum, respectively.

AIR LEAKAGES

Air infiltration rates must not exceed 0.3 cfm/ft² for windows and nonresidential single doors (swinging and sliding), and 1.0 cfm/ft² for nonresidential double doors (swinging).

U-FACTOR

The fenestration product's U-factor shall be rated in accordance with **NFRC 100**¹, or use the applicable U-factor set forth in **Table 110.6-A** of the Energy Standards presented on page 40 of this guide.

EXCEPTIONS TO SECTION 110.6(A) 2

- If the fenestration product is a skylight or a vertical site-built fenestration product in a building covered by the nonresidential standards with less than 1,000 square feet of site-built fenestration, the default U-factor may be calculated as set forth in **Reference Nonresidential Appendix NA6** and provided on page 40.
- If the fenestration product is an alteration consisting of any area replacement of glass in a skylight product or in a vertical site-built fenestration product, in a building covered by the nonresidential standards, the U-factor may be calculated as set forth in **Reference Nonresidential Appendix NA6** and provided on page 40.

U-FACTOR CALCULATION METHOD

$$U_T = C_1 + (C_2 \times U_c)$$

- U_T = U-factor of the total fenestration including glass and frame
- C_1 = Coefficient selected from **Table NA6-5**
- C_2 = Coefficient selected from **Table NA6-5**
- U_c = Center of glass U-factor calculated in accordance with **NFRC 100 Section 4.5.3.1**¹

CONTINUED ON PAGE 39

¹ National Fenestration Rating Council. Procedure for Determining Fenestration Product. ANSI/NFRC 100. 2017.

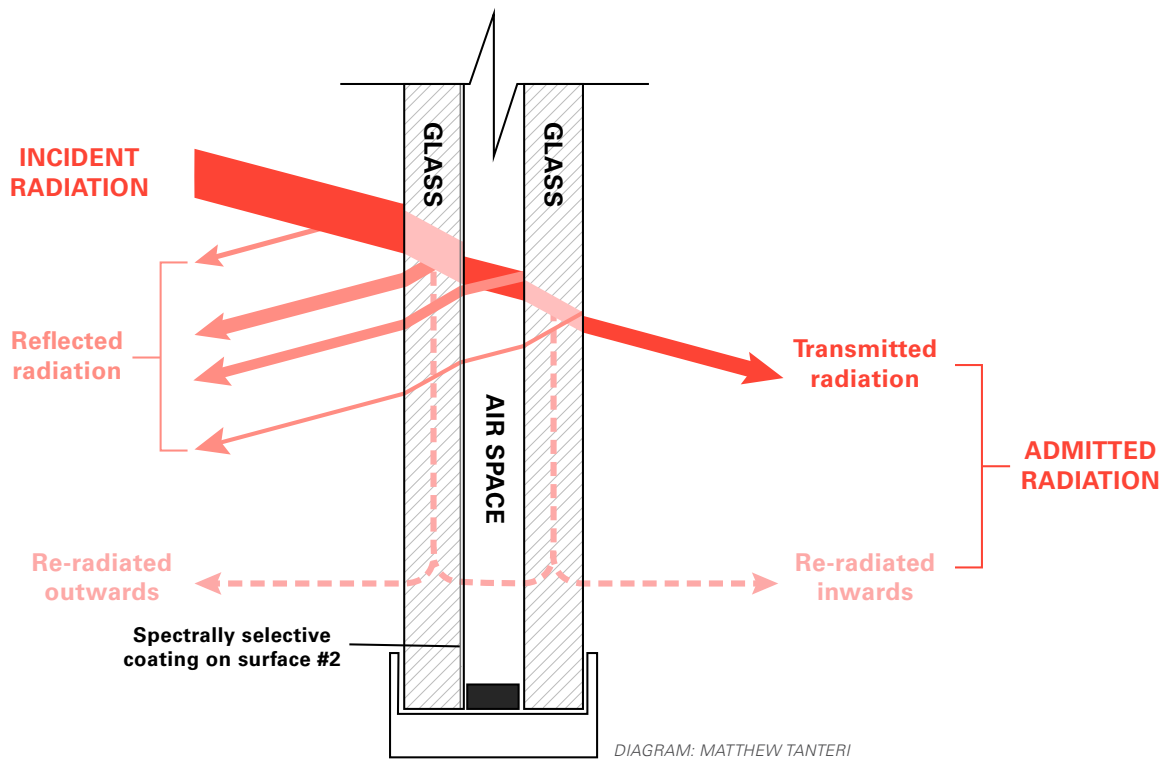

FIGURE 35 Schematic drawing showing the transmitted, reflected and absorbed fractions of the incident solar radiation.

reflectance (R), and absorptance (A) properties of the glazing and/or shading system, which have different values for the visible and solar spectra (**FIGURE 35**).

The key parameters for visual performance are the Visible Transmittance and Reflectance, while the key parameters for thermal performance are the Solar Transmittance and Absorptance.

SOLAR HEAT GAIN COEFFICIENT (SHGC)

The absorbed solar radiation increases the temperature of the glazing and/or shading system, resulting in increased emitted radiation in the long-IR region of the spectrum.

Part of emitted radiation flows towards the outdoors (outward flowing fraction) and part towards the interior space (inwards flowing fraction). The combination of the solar transmittance and the inwards flowing fraction of the absorbed solar radiation is referred to as solar heat gain (**FIGURE 35**).

SOLAR HEAT GAIN COEFFICIENT (SHGC)

The fenestration product’s SHGC shall be rated in accordance with **NFRC 200**², or use the applicable SHGC set forth in **Table 110.6-B**.

EXCEPTIONS TO SECTION 110.6(A) 3

- If the fenestration product is a skylight or a vertical site-built fenestration product in a building covered by the nonresidential standards with less than 1,000 square feet of site-built fenestration, the SHGC may be calculated as set forth in **Reference Nonresidential Appendix NA6**.
- If the fenestration product in a non-residential building is an alteration consisting of any area replacement of glass in a skylight product or in a vertical site-built fenestration product, a SHGC may be calculated as set forth in **Reference Nonresidential Appendix NA6**.

CONTINUED ON PAGE 42

2 National Fenestration Rating Council. Procedure for Determining Fenestration Product Solar Heat Gain Coefficient and Visible Transmittance at Normal Incidence. ANSI/NFRC 200. 2017.

Table 110.6-A: Energy Commission-Defined Fenestration Product U-Factor

Frame	Product Type	U-Factor		
		Single Pane ^{3,4}	Double Pane ^{1,3,4}	Glass Block ^{2,3}
Metal	Operable	1.28	0.79	0.87
	Fixed	1.19	0.71	0.72
	Greenhouse / Garden Window	2.26	1.40	N.A.
	Doors	1.25	0.77	N.A.
	Skylight	1.98	1.30	N.A.
Metal, Thermal Break	Operable	N.A.	0.66	N.A.
	Fixed	N.A.	0.55	N.A.
	Greenhouse / Garden Window	N.A.	1.12	N.A.
	Doors	N.A.	0.59	N.A.
	Skylight	N.A.	1.11	N.A.
Nonmetal	Operable	0.99	0.58	0.60
	Fixed	1.04	0.55	0.57
	Greenhouse / Garden Window	1.94	1.06	N.A.
	Doors	0.99	0.53	N.A.
	Skylight	1.47	0.84	N.A.

¹ For all dual-glazed fenestration products, adjust the listed U-factors as follows:
 a. Add 0.5 for products with dividers between panes if spacer is less than 7/16 inch wide.
 b. Add 0.05 to any product with true divided lite (dividers through the panes).
² Translucent or transparent panels shall use glass block values when not rated by NFRC 100.
³ Visible Transmittance (VT) shall be calculated by using Reference Nonresidential Appendix NA6
⁴ Windows with window film applied that is not rated by NFRC 100 shall use the values from this table.

Table NA6-5: Coefficients for U-Factor Computation (presented on page 38)

Product Type	Frame Type	C ₁	C ₂
Site-Built Vertical Fenestration	Metal	0.311	0.872
	Metal Thermal Break	0.202	0.867
	Non-Metal	0.202	0.867
Skylights with a Curb	Metal	0.711	1.065
	Metal Thermal Break	0.437	1.229
	Non-Metal	0.437	1.229
Skylights with no Curb	Metal	0.195	0.882
	Metal Thermal Break	0.310	0.878
	Non-Metal	0.310	0.878

TABLE 1. Typical values for Visible Light Transmittance (VLT), Solar Heat Gain Coefficient (SHGC), and Light-To-Solar-Gain (LSG) ratio for different glazing types.

Glazing Type	Glazing Tint	VLT (%)	SHGC (%)	LSG
Standard Low-e	Clear	79	70	1.13
	Grey	40	45	0.89
	Bronze	48	50	0.96
	Blue-Green	60	39	1.54
Reflective Low-e	Reflective Grey	15	27	0.56
	Reflective Bronze	19	30	0.63
Spectrally Selective Low-e	Low Iron Green	64	27	2.37
	Green	49	28	1.75
Skylight Low-e Double with Argon Fill	Clear	53	32	1.66
	White	38	30	1.27
Skylight Triple	White	45	58	0.78

Table 110.6-B: Energy Commission-Defined Solar Heat Gain Coefficient (SHGC)

Frame Type	Product	Glazing	Fenestration Product SHGC		
			Single Pane ^{2,3} SHGC	Double Pane ^{2,3} SHGC	Glass Block ^{1,2} SHGC
Metal	Operable	Clear	0.80	0.70	0.70
	Fixed	Clear	0.83	0.73	0.73
	Operable	Tinted	0.67	0.59	N.A.
	Fixed	Tinted	0.68	0.60	N.A.
Metal, Thermal Break	Operable	Clear	N. A.	0.63	N.A.
	Fixed	Clear	N. A.	0.69	N.A.
	Operable	Tinted	N. A.	0.53	N.A.
	Fixed	Tinted	N. A.	0.57	N.A.
Nonmetal	Operable	Clear	0.74	0.65	0.70
	Fixed	Clear	0.76	0.67	0.67
	Operable	Tinted	0.60	0.53	N.A.
	Fixed	Tinted	0.63	0.55	N.A.

¹Translucent or transparent panels shall use glass block values when not rated by NFRC 200.

²Visible Transmittance (VT) shall be calculated by using Reference Nonresidential Appendix NA6.

³Windows with window film applied that is not rated by NFRC 200 shall use the values from this table.



ISTOCK.COM/ISMALIGOV

The solar heat gain coefficient (SHGC) is defined as the fraction of the incident solar radiation that is transmitted through the glazing and/or shading assembly. It is expressed as a number between 0 and 1 and can refer to the glazing material alone or the entire fenestration system.

The lower the SHGC of a glazing or fenestration system, the less solar heat it transmits and the greater its shading ability.

LIGHT-TO-SOLAR-GAIN RATIO (LSG)

The light-to-solar-gain ratio (also known as Coolness Index) is a derivative metric, computed by dividing the VLT by SHGC, that indicates the ability of the glazing or fenestration system to provide daylight without excessive solar heat gain. The higher its value, the better the performance of the glazing during cooling periods (TABLE 1).

Relative Solar Heat Gain Coefficient (RSHGC)

Relative Solar Heat Gain Coefficient (RSHGC) is the ratio of solar heat gain through a fenestration product (corrected for external shading) to the incident solar radiation. Solar heat gain includes directly transmitted solar heat and absorbed solar radiation, which is then re-radiated, conducted, or convected into the space.

SHGC CALCULATION METHOD

$$\text{SHGC}_T = 0.08 + (0.86 \times \text{SHGC}_c)$$

- SHGC_T = SHGC of the fenestration including glass and frame
- SHGC_c = Center of glass SHGC calculated in accordance with **NFRC 200 Section 4.5.1.1**

The Energy Standards allow exceptions for the solar heat gain coefficient in select applications.

EXCEPTION: SECTION 140.3(A) 5C

An area-weighted average Relative Solar Heat Gain Coefficient (RSHGC) of 0.56 or less shall be used for windows that are in the first story of exterior walls that form a display perimeter; and for which codes restrict the use of overhangs to shade the windows.

For vertical fenestration containing chromogenic type glazing: the lower-rated labeled RSHGC shall be used with automatic controls to modulate the amount of heat flow into the space in multiple steps in response to daylight levels or solar intensity; and chromogenic glazing shall be considered separately from other fenestration; and area-weighted averaging with other fenestration that is not chromogenic shall not be permitted.

VISIBLE TRANSMITTANCE (VT)

The glazing's VT shall be rated in accordance with **NFRC 200** or **ASTM E972**; for tubular skylights, VT shall be rated using **NFRC 203**³.

CONTINUED ON PAGE 44

³ National Fenestration Rating Council. Procedure for Determining Visible Transmittance of Tubular Daylighting Devices. ANSI/NFRC 203. 2017.

SOLAR-OPTICAL PROPERTIES AND INCIDENT ANGLE OF RADIATION

As the incident angle of radiation increases from 0 degrees (normal to the surface) to 90 degrees (parallel to the surface), the incident radiation per unit area decreases by the cosine of the incident angle (**Lambert's Cosine Law**) (**FIGURE 36**).

The incident angle of radiation on glazing also affects the solar optical properties with significant decrease in transmittance and corresponding increase in reflectance as the incident angle exceeds 70 degrees (**FIGURE 37**).

The single angle effect on solar optical properties can be significant for different fenestration orientations. Compared to south-facing vertical clerestory windows, horizontal skylights transmit more solar radiation during the summer and less during the winter in California (**FIGURE 38**).

Lambert's Cosine Law: $E_{\theta} = E * \cos(\theta)$

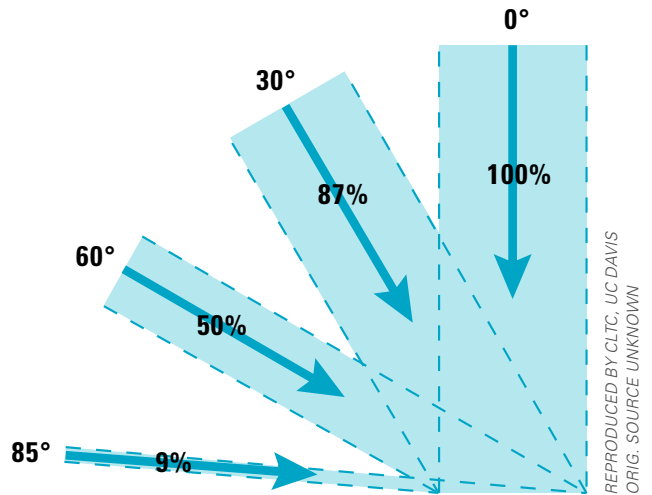

FIGURE 36 The incident radiation per unit area decreases by the cosine of the incident angle.

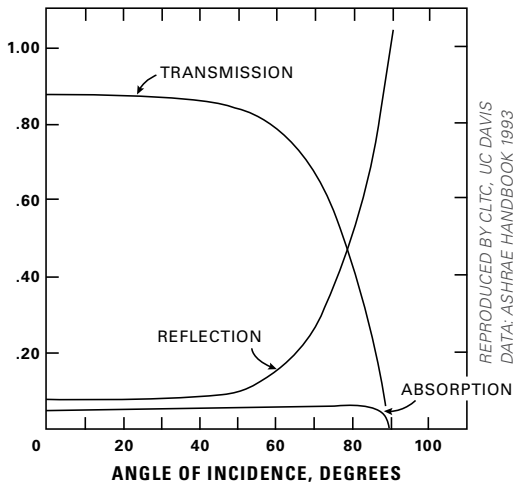

FIGURE 37 Single-pane clear glass optical and solar properties as functions of incident angle on the glass surface.

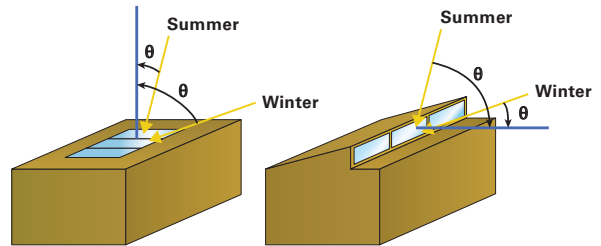

FIGURE 38 South-facing clerestories receive more radiation per unit area during the winter than during the summer, while horizontal skylights receive more during the summer and less during the winter.

GLASS & GLAZING TYPES

CLEAR GLASS

Clear glass is the most common material used in fenestration assemblies. Glass is a material with unique physical structure that combines the random atomic arrangement of liquid, which is “frozen” in place, so that it is a solid and permanent substance. The ASTM defines glass as “an inorganic product of fusion, which has cooled to a rigid condition without crystallizing”.

Clear glass has very high visible light transmittance (VLT) and solar heat gain coefficient (SHGC). It is transparent, impervious to common elements and many harsh chemicals and liquids, with exceptional resistance to abrasions and surface scratches. It is used as the basis for many different types of glazing systems that also include different coatings and/or special films.

EXCEPTION: SECTION 110.6(A) 4

1. If the fenestration product is a skylight or a vertical site-built fenestration product in a building covered by the nonresidential standards with less than 1,000 square feet of site-built fenestration, the VT may be calculated as set forth in **Reference Nonresidential Appendix NA6**.
2. If the fenestration product is an alteration consisting of any area; replacement of glass in a skylight product or in a vertical site-built fenestration product in a building covered by the nonresidential standards, the VT may be calculated as set forth in **Reference Nonresidential Appendix NA6** and provided below.

VISIBLE TRANSMITTANCE CALCULATION METHOD

$$VT_T = VT_F \times VT_C$$

- VT_T = Total performance of the fenestration including glass and frame
- VT_F = 0.53 for projecting windows, such as casement and awning windows
- VT_F = 0.67 for operable or sliding windows
- VT_F = 0.77 for fixed or non-operable windows
- VT_F = 0.88 for curtain wall/storefront, site-built and manufactured non-curb mounted skylights
- VT_F = 1.0 for curb mounted manufactured skylights
- VT_C = Center of glass VT is calculated in accordance with **NFRC 200 Section 4.5.1.1** or **NFRC 202**⁴ for Translucent Products or **NFRC 203** for Tubular Daylighting Devices and Hybrid Tubular Daylighting Devices or **ASTM E972**

Examples of typical commercial products are provided in **TABLE 1**.

CONTINUED ON PAGE 46

4 National Fenestration Rating Council. Procedure for Determining Translucent Fenestration Product Visible Transmittance at Normal Incidence. ANSI/NFRC 202. 2017.

TINTED GLASS

Tinted glass is colored glass, produced by incorporating a mineral mixture and comes in a wide variety of colors (FIGURE 39). Compared to clear glass, tinted glass has lower light transmittance and lower SHGC, but the same U-factor.

Tinted glass is used for esthetic and solar shading purposes. While lower SHGC values are beneficial for reducing associated cooling loads, lower VLT limits the benefits from electric lighting savings.

Depending on the tint color, tinted glass may affect the spectrum of the transmitted daylight, and thus the color rendering of outdoor and indoor surfaces (FIGURE 40). Green and blue tints have higher transmittance than bronze and gray tints. Gray tints have the least spectral effects, preserving good color rendering.

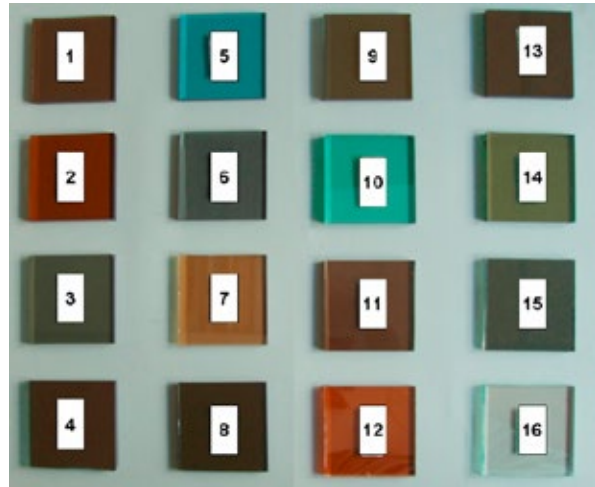

PHOTO: L. DOULOS*, A. TSANGRASSOULIS*, F.V. TOPALIS*
 A. NATIONAL TECHNICAL UNIVERSITY OF ATHENS
 B. UNIVERSITY OF THESSALY

FIGURE 39 Photograph of samples of commonly used tinted glass.

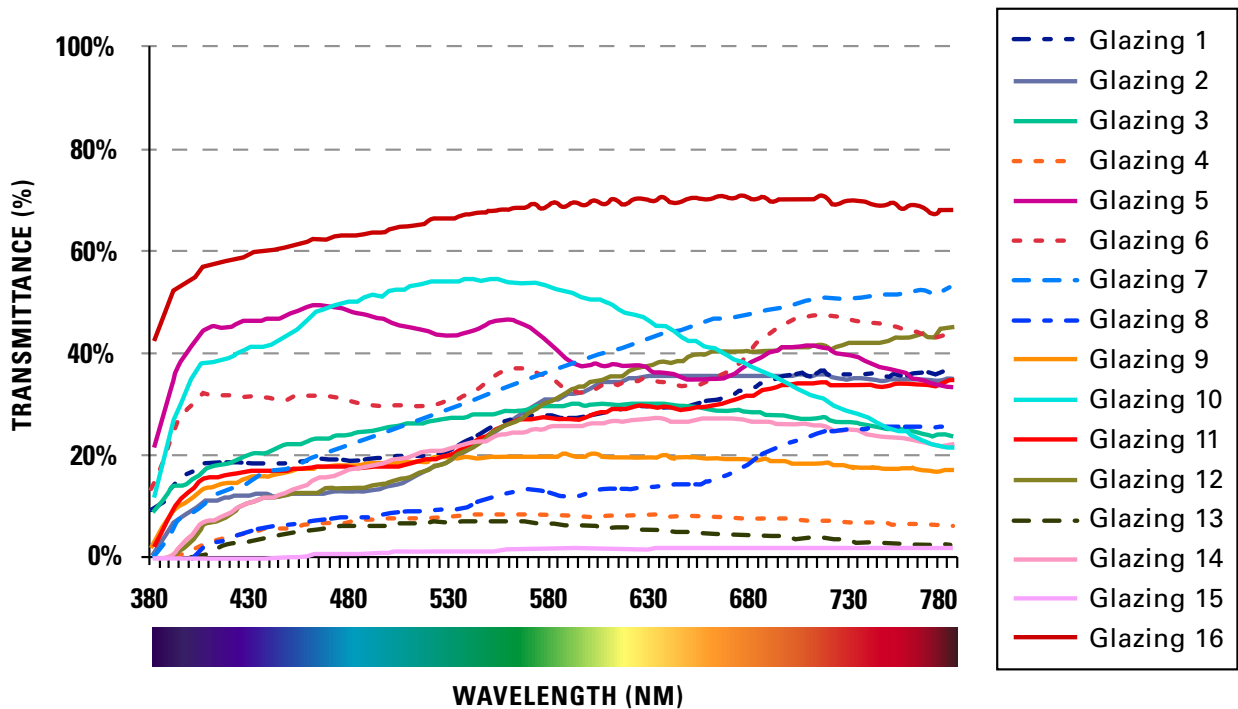

DIAGRAM: L. DOULOS*, A. TSANGRASSOULIS*, F.V. TOPALIS*
 A. NATIONAL TECHNICAL UNIVERSITY OF ATHENS
 B. UNIVERSITY OF THESSALY

FIGURE 40 Spectral transmittance of the glazing samples shown in Figure 39.



FIGURE 41 Reflective glazings prevent view of interiors from the outside during the day, as the reflected radiation is significantly higher than that transmitted from the interior light levels. However, they allow a clear view of interiors during the night when the electric lights are on. The opposite is true for an outdoor view from the inside of the space.

REFLECTIVE GLASS

Reflective glass is produced by applying a highly reflective metallic coating to the glass surface. This coating can reduce the SHGC and VT either moderately or dramatically, depending on the thickness of the coating.

The reflective coating acts like a mirror on the side with the higher light levels, while allowing view from the side with a lower light level. This effectively supports occupant view and privacy during the day but compromises both during the night (FIGURE 41).

The higher the reflectance, the lower the visible transmittance and the potential for electric lighting savings.

LOW-EMISSIVITY COATINGS & FILMS

Low-emissivity (Low-E) coatings and films are microscopically thin, virtually invisible, metal oxide layers in glazing assemblies, aimed at reducing primarily the U-factor by suppressing radiative heat flow. Typically, low-E coatings are transparent to visible and short-wave infrared radiation and reflective of long-wave infrared radiation.

LABELING

Fenestration products are required to include two labels, one temporary for use during the inspection and one permanent label.

- Have a temporary label: **Section 10-111(a) 1**. The temporary label shall not be removed before inspection by the enforcement agency.
- Have a permanent label or a label certificate: **Section 10-111(a) 2** if the product is rated using NFRC procedures (FIGURE 42).

ENERGY STANDARDS

 World's Best Window Co. Series "2000" Casement Vinyl Clad Wood Frame Double Glazing•Argon Fill•Low E XYZ-X-1-00001-00001	
ENERGY PERFORMANCE RATINGS	
U-Factor (U.S. / I-P)	Solar Heat Gain Coefficient
0.35	0.32
ADDITIONAL PERFORMANCE RATINGS	
Visible Transmittance	Air Leakage (U.S. / I-P)
0.51	≤ 0.3
Condensation Resistance	
51	—

FIGURE 42 An example label for windows from the National Fenestration Rating Council (NFRC). The NFRC label compares energy performance ratings through U-Factor, Solar Heat Gain Coefficient, Visible Transmittance, and Air Leakage.

CONTINUED ON PAGE 49

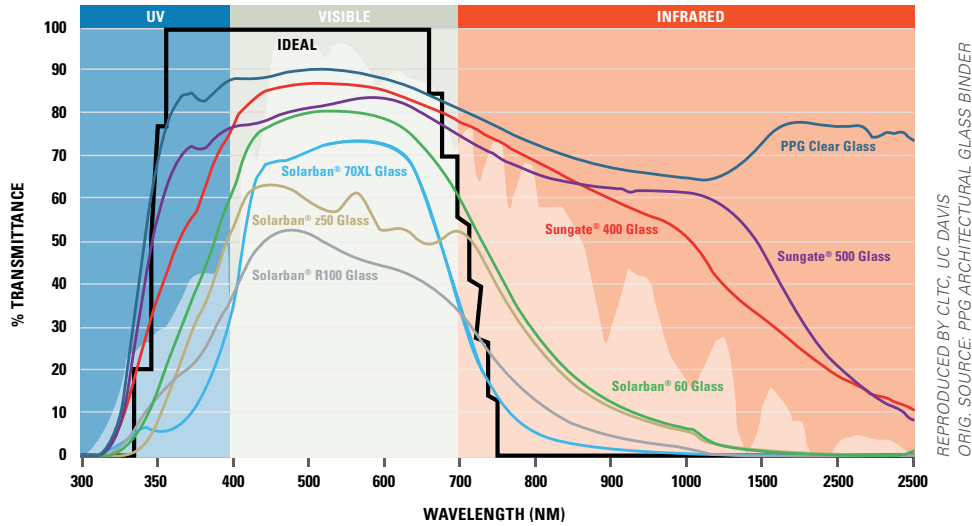

REPRODUCED BY CLTC, UC DAVIS
ORIG. SOURCE: PPG ARCHITECTURAL GLASS BINDER

FIGURE 43 Spectral transmittance of clear glass and various spectrally selective glazings.

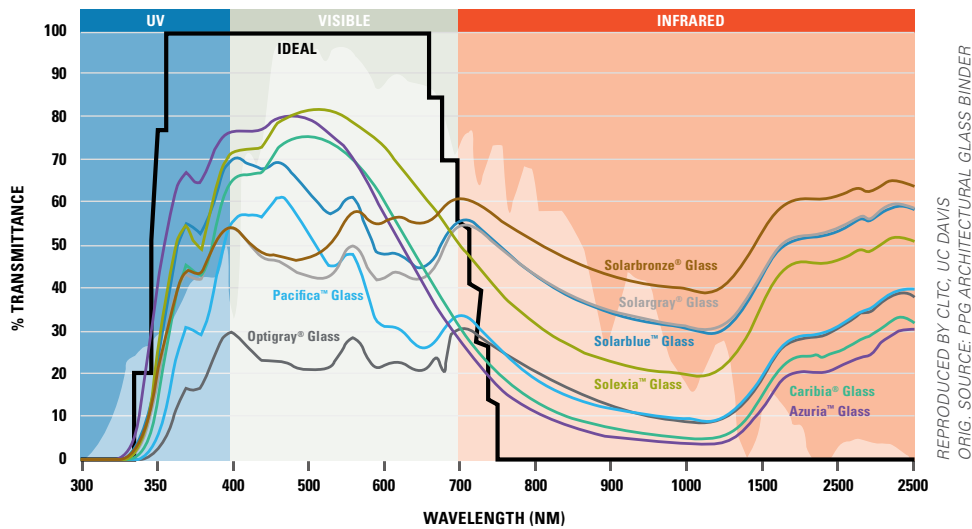

REPRODUCED BY CLTC, UC DAVIS
ORIG. SOURCE: PPG ARCHITECTURAL GLASS BINDER

FIGURE 44 Spectral transmittance of tinted glass and various spectrally selective glazings.

Originally used in residential applications to prevent heat losses during the winter, low-e coatings are now standard in most glazing systems, as they can also reduce heat gains during the summer, which is most beneficial for both residential and commercial applications.

Because of their sensitivity to humidity and scratching, low-e coatings are usually applied to the inner surfaces of double- or triple-pane glazing systems, dramatically reducing U-factor and SHGC, while maintaining high VLT.

Low-E coatings also reflect UV light, which protects interior objects' color from fading.

SPECTRALLY SELECTIVE GLAZINGS

Spectrally selective glazings are coated or tinted glazings that are transparent to some wavelengths of electromagnetic radiation and reflective to others. Typical spectrally selective coatings aim at transmitting visible light while reducing short- and long-wave infrared radiation (FIGURE 43 and FIGURE 44).

Spectrally selective glazings offer the highest LSG values and thus the best performance for commercial applications, as they can contribute to significant reduction in electric lighting with minimal cooling penalty.



PHOTOS: KALWALL

FIGURE 45 Photographs of translucent glazing installations.

TRANSLUCENT GLAZINGS

Translucent glazings, also called diffuse glazings, aim at utilizing the direct solar radiation for indoor illumination, by reducing intensity and diffusing the sun light, through low, diffuse reflectance. Due to their diffuse transmittance, these glazings do not allow view to the outdoors. They are usually used in skylight and clerestory applications as well as window applications above and/or below eye level (**FIGURE 45**).

Translucent glazings are excellent in eliminating glare from direct solar penetration and also in providing excellent daylight indoors in terms of intensity and color rendering. As they are equivalent to area light sources, they help eliminate shadows, making them excellent for work and sport environments.

DYNAMIC GLAZINGS

Dynamic glazings, also called chromogenic glazings, include layers that can change their solar optical properties either passively or actively, through dynamic tinting glazing layers. The most common passive technologies include photochromic and thermochromic glazings, which change their solar and visible transmittance based on incident UV radiation and temperature, respectively. The most common active technology is electrochromic glazings, which change their solar and visible transmittance on demand. In all cases the change in solar optical properties is realized through tinting.

PHOTOCHROMIC GLAZINGS

Photochromic glazing is commonly used in eye glasses (transition lenses), but are not used in building applications because they can only be produced economically in small sizes.

THERMOCHROMIC GLAZINGS

Thermochromic glazings contain materials that absorb solar heat, increasing their temperature, which in turn reduces their solar and visible transmittance, based on the temperature of the glazing.

Thermochromic glazings have recently entered the buildings market and have the potential to increase comfort and reduce cooling loads.

Depending on materials used, some commercial offerings change faster than others, but in all cases transition speed is dependent on the glass temperature.

Manufacturer-specific design determines if the product has continuous tinting or two tint levels where the change is triggered by a temperature set point. Two-tint windows typically take five to twenty minutes to change tint in normal use.

ELECTROCHROMIC GLAZINGS

Active technologies include electrochromic glazings, which change their solar and visible transmittance on demand, through application of voltage between two transparent layers that enclose a very thin film stack of ceramic metal oxide coatings and three electrochromic layers (FIGURE 46).

Today's electrochromic glazings support four pre-defined tint levels, including fully-tinted and non-tinted states. The corresponding VLT and SHGC values of the four different states are approximately 2%, 6%, 21% and 62%, and 0.09, 0.11, 0.17 and 0.47, respectively. Electrochromic glazings are operated manually and/or automatically to improve comfort and energy efficiency with minimal effects on view, taking between 5 and 10 minutes to switch from one tint level to the next.

The Energy Standards allow exceptions for the U-factor of chromogenic products, such as electrochromic glazing.

EXCEPTION: SECTION 140.3(A) 5B

For vertical fenestrations containing chromogenic type glazing:

1. The lower-rated labeled U-factor shall be used with automatic controls to modulate the amount of heat flow into the space in multiple steps in response to daylight levels or solar intensity; and
2. Chromogenic glazing shall be considered separately from other fenestration; and
3. Area-weighted averaging with other fenestration that is not chromogenic shall not be permitted.

CONTINUED ON PAGE 51



PHOTOS: SAGE GLASS
BALL STATE UNIVERSITY, MUNCIE, INDIANA

FIGURE 46 Photographs of atrium with electrochromic glazing at high (top), medium (middle), and low (bottom) transmittance states.

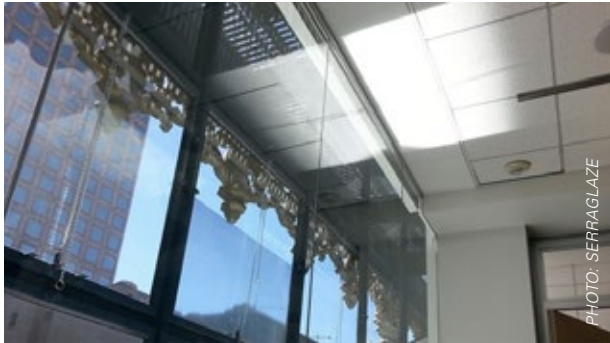

FIGURE 47 Photograph of space with light redirecting film installed at the upper area of one window pane, showing the sun shape on the ceiling from the redirection of direct solar radiation.



FIGURE 48 Photograph of light redirecting microstructure installed on a window, showing the direct and redirected patterns on the transmitted radiation on the side wall of the space.

LIGHT-REDIRECTING GLAZINGS

Light redirecting glazings include optical microstructures that change the direction of incoming radiation. Their main objective is to redirect direct solar radiation towards the ceiling, reducing the potential for direct sun glare and increasing daylight levels further away from windows through reflection of redirected sunlight off the ceiling of the space (FIGURE 47 and FIGURE 48). While these technologies work very well when the sun is within a certain range of incoming directions, their performance is compromised for sun directions outside of the effective range.

SINGLE, DOUBLE, AND TRIPLE GLAZING SYSTEMS

One approach to increasing the U-factor of fenestration systems is use of two or three glass panes (double- and triple-pane, respectively), separated by spacers for improved insulation. The volume between glass panes is usually hermetically sealed and may be vacuum or include inert non-toxic, clear gasses, such as argon or krypton, which further increase insulating value. On average, each pane of glass reduces the U-value by 50%, or effectively doubling the insulating value.

The glass or glazing panes in double- and triple-pane glazing systems can be of any glass type and include a number of low-e or other coatings in the interior surfaces of the glass or glazing panes (FIGURE 49).

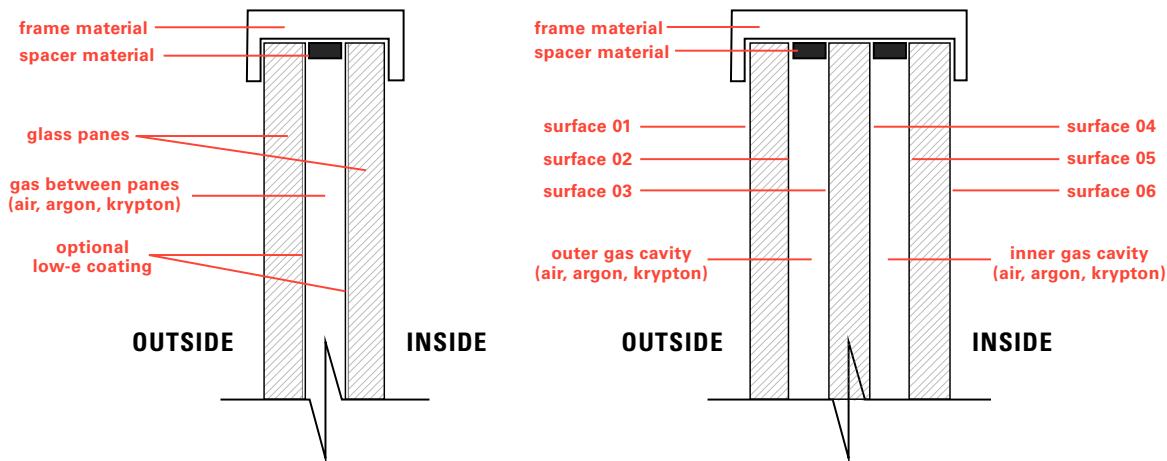

FIGURE 49 Schematic drawings of double and triple glazing systems.

DIAGRAM: MATTHEW TANTERI

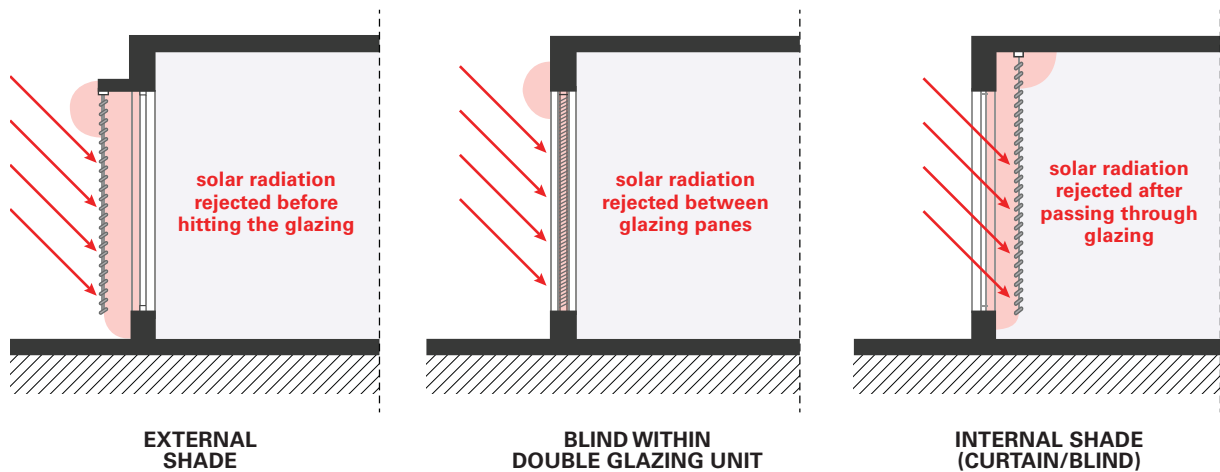

DIAGRAM: MATTHEW TANTERI

FIGURE 50 Schematic drawing showing the effect of a shading device placed on the exterior of the glazing system (left), between glazing panes (center) and on the interior of the glazing system (right).

SHADING STRATEGIES AND TECHNOLOGIES

The goal of shading systems is protection from direct solar radiation to mitigate glare and solar heat gain. Direct solar radiation can be blocked, using opaque shading elements, and/or reduced in intensity, using transparent or translucent materials of different visible and solar transmittance, including glazings, fabrics, and plastics.

Shading elements can be horizontal or vertical. Horizontal shading elements are best at mitigating direct solar radiation from high solar altitudes, while vertical shading elements are best at mitigating direct solar radiation from low solar angles. Horizontal and vertical shading systems can also be combined to mitigate direct solar from a wider range of incoming directions.

EXTERIOR AND INTERIOR SHADING SYSTEMS

Depending on their position relative to the glazing assembly of the fenestration, shading systems are classified into exterior, between glass panes, and interior systems (**FIGURE 50**).

REQUIREMENTS FOR VENTILATION (SECTION 120.1)

Outside air must be provided for ventilation for all enclosed spaces in a building, other than refrigerated warehouses and other spaces or buildings that are not normally used for human occupancy and work.

Operable windows and skylights can provide natural ventilation to a space. Naturally ventilated spaces must be permanently open to and within 20 feet of operable wall or roof openings to the outdoors, the operable area of which is not less than 5 percent of the conditioned floor area of the naturally ventilated space. Where openings are covered with louvers or otherwise obstructed, operable area shall be based on the unobstructed area through the opening.

Naturally ventilated spaces in high-rise residential dwelling units and hotel/motel guest rooms must be open to and within 25 feet of operable wall or roof openings to the outdoors.

The means to open required operable openings must be readily accessible to building occupants whenever the space is occupied.



FIGURE 51 Photographs of building facades with exterior shading systems.

EXTERIOR SHADING SYSTEMS

Exterior systems are the most effective in reducing solar heat gain, as they block or reduce the solar radiation before it passes through the glazing. If solar radiation passes through the glazing assembly of the fenestration system, it is absorbed by interior surfaces and then re-emitted in the long-infrared spectrum, which cannot penetrate the glazing assembly and results in increased thermal loads.

Exterior shading systems include horizontal and/or vertical shading elements, such as overhangs, light shelves, horizontal and vertical louvers, metal screens and awnings, etc. They can be opaque, transparent or translucent (FIGURE 51).

Horizontal shading systems are best for high solar altitude angles, while vertical shading systems are best for low solar altitude angles (FIGURE 52 and FIGURE 53). In both cases, the important characteristic is their profile angle, which is the highest angle that they can block on a plane normal to the shading elements. This is a function of width of the shading elements and between two consecutive elements (FIGURE 54).

While exterior shading systems are better in terms of shading effectiveness than interior systems, they are usually more expensive as they require material and construction processes that can withstand weather conditions.

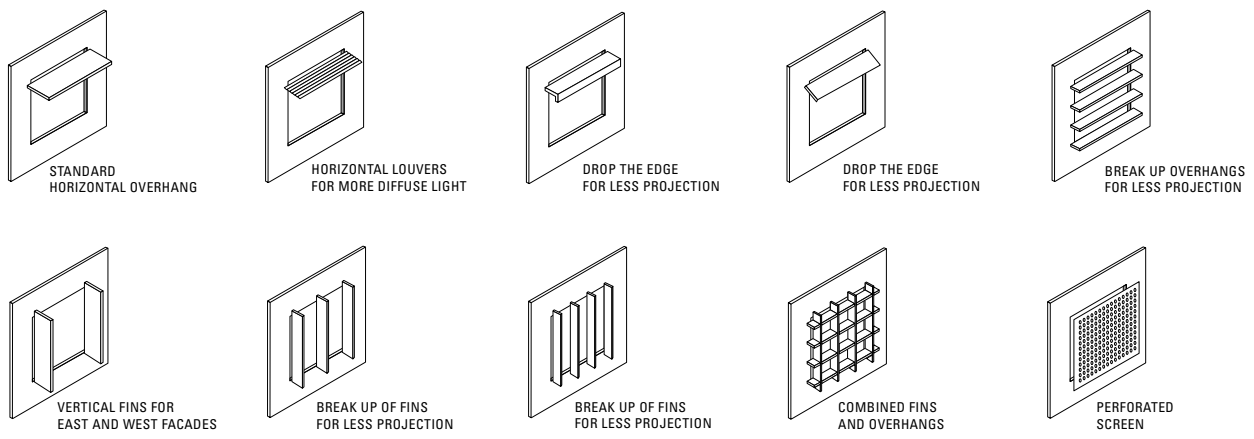
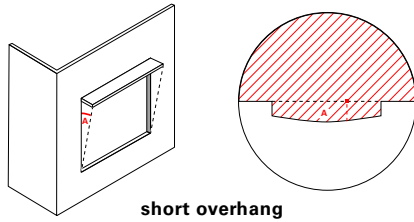

FIGURE 52 Schematic drawings of horizontal and vertical exterior shading devices.

DIAGRAM: MATTHEW TANTERI

HORIZONTAL SHADE: DEPTH



HORIZONTAL SHADE: OFFSET

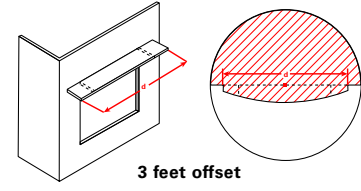
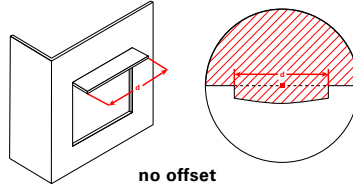

VERTICAL SHADE: DEPTH

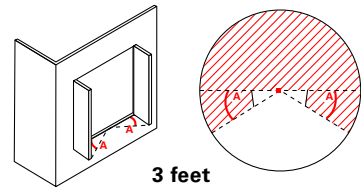
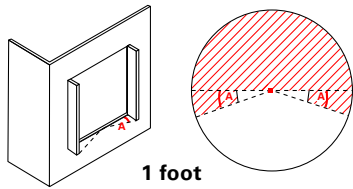
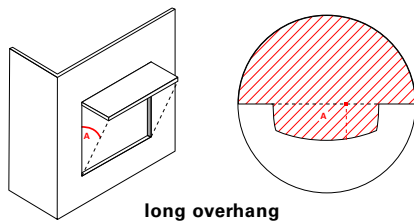

VERTICAL SHADE: OFFSET

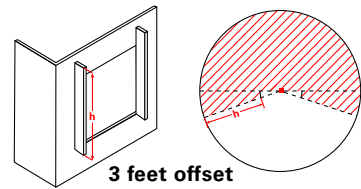
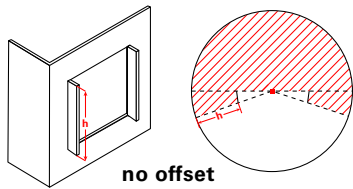
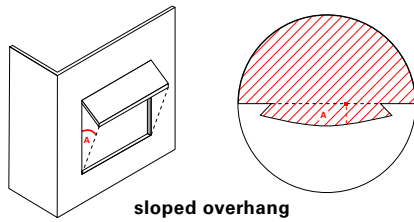

DIAGRAM: MATTHEW TANTERI

FIGURE 53 Shadow masks of exterior overhangs and vertical fins.

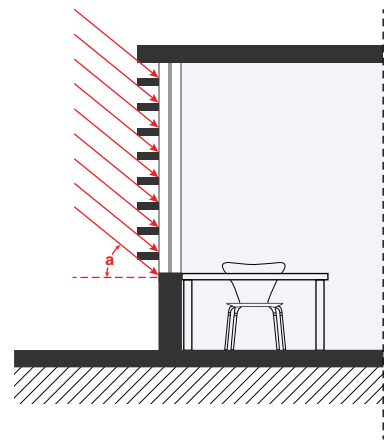
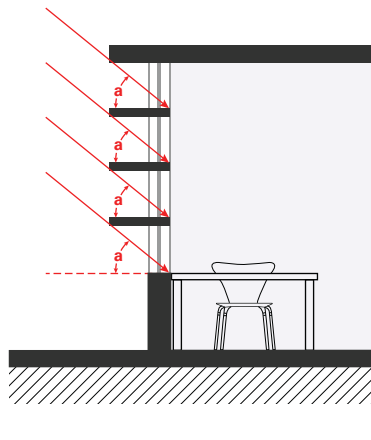
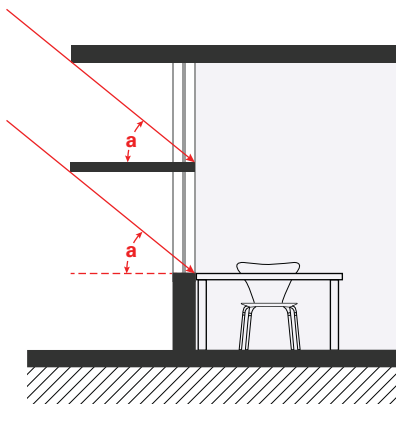

DIAGRAM: MATTHEW TANTERI

FIGURE 54 The same cut-off angle for solar radiation can be achieved with different combinations of the width of the shading elements and the distance between two consecutive elements.

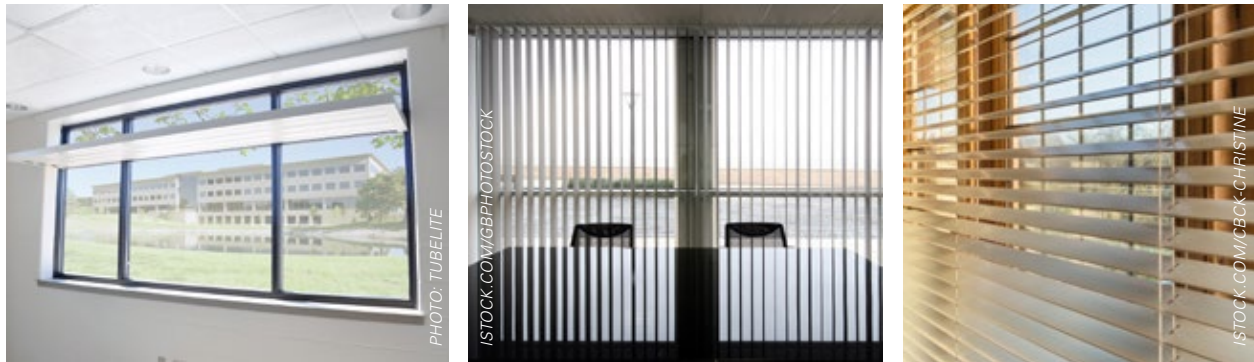

FIGURE 55 Photographs of interior light shelf and interior shading systems with horizontal and vertical elements.

INTERIOR SHADING SYSTEMS

Interior shading systems intercept the solar radiation after it has passed through the glazing assembly, reflecting part of it and absorbing and/or transmitting the rest. Dark-colored interior shading absorbs most of the transmitted solar radiation, contributing to thermal loads. Light-colored interior shading reflects most of the transmitted solar radiation maintaining the spectral composition, by reflecting it through the glass to the outdoors.

Interior shading systems are not as effective in shading compared to exterior systems, but they are significantly lower in cost, especially considering life-cycle cost that includes maintenance.

Interior systems include horizontal and vertical shading elements, such as interior light shelves, Venetian blinds, vertical louvers (FIGURE 55), and rolling shades made from a very large variety of opaque, transparent or woven materials (FIGURE 56).

BETWEEN GLASS PANES SHADING SYSTEMS

Shading systems installed between glazings combine the advantages of exterior and interior shading systems. They include shading systems that can fit in the cavities between glazing panes, such as blinds, louvers and rolling films and shades (FIGURE 57).



FIGURE 56 Interior pull-down/up shades come in a wide variety of materials in terms of visible and solar transmittance and reflectance.

STATIC VS. DYNAMIC SHADING SYSTEMS

Shading systems can be static, permanently mounted horizontal and/or vertical shading elements, which are designed to block or mitigate solar radiation from specific incoming directions. Shading systems can also be dynamic, or operable, supporting adjustment of horizontal and/or vertical elements in ways that can be effective for a variety of incoming directions of solar radiation.

MANUAL VS. AUTOMATED SHADING SYSTEMS

The operation of dynamic shading systems can be manual or motorized and can be left to occupants, or be automated based on environmental conditions.

Automated shading systems are most effective, as they continuously adjust to maintain best possible performance in terms of comfort and energy efficiency.

Automated operation can be based on a single criterion, such as potential for glare, or a combination of criteria, such as potential for glare, maximization of view, and reduction of cooling loads. Optimization of automated operation for comfort and energy efficiency requires information about occupancy, indoor and outdoor light levels, and the state of the electric lighting and HVAC system in order to achieve desirable adjustments in visible light transmittance and solar heat gain coefficient.



PHOTO: CLTC, UC DAVIS

FIGURE 57 Photograph of shading systems between glazing panes.



ISTOCK.COM/KINWUN

INTERIOR & LIGHTING DESIGN

Interior and lighting design are most important in realizing energy savings by adjusting electric lighting based on available daylight. Interior design is also very important in maintaining luminous comfort. The key interior design parameters that affect daylight performance are the reflectance of interior surfaces and the arrangement of furniture. The key lighting design parameters are the layout of luminaires and the design and implementation of the lighting control system that adjusts electric lighting based on available daylight.

REFLECTANCE OF INTERIOR SURFACES

The reflectance of interior surfaces, including furniture, is very important for daylighting performance. Even the best architectural and fenestration designs can fail if the interior surfaces do not contribute towards maintaining the daylight transmitted through fenestration.

There are two key surface reflectance properties that are critical to daylighting performance: color and texture. The lighter the color of interior surfaces the more daylight that reflects, keeping it alive in the space. The darker the color, the less the reflected daylight, and the lower the overall daylight levels and the brightness of interior surfaces. The rougher the texture of interior surfaces, the larger the spread of reflected light off the surface in all directions. The shinier the texture, the more concentrated the reflected light, and the higher the potential to produce glare conditions, especially through reflection of direct sunlight.

Daylight levels and brightness of interior surfaces is the result of all inter-reflections of light among all interior surfaces. Some interior surfaces cannot receive direct light from the sun or the sky, such as the ceiling, the window wall, and the areas of the side walls above window head height; they can only receive daylight reflected off exterior surfaces and the rest of the interior surfaces (**FIGURE 58** and **FIGURE 59**). This makes the reflectance of the floor, the side walls, and the furniture most important for directing daylight to the surfaces that cannot receive daylight directly. The higher the reflectance of the floor and the side walls, the more the daylight that will be reflected towards the ceiling and front wall. The higher the reflectance of the ceiling and the front wall, the more daylight will be inter-reflected, keeping it alive to contribute to illumination needs (**FIGURE 60**).

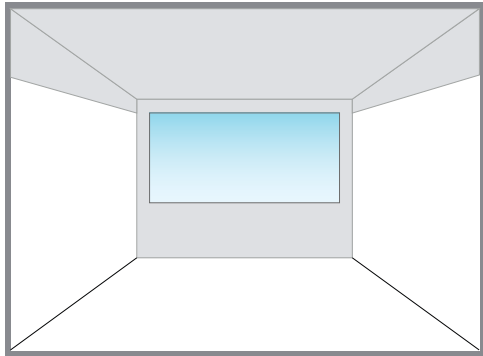

REPRODUCED BY CLTC, UC DAVIS

FIGURE 58 The ceiling, window wall, and areas of the side walls above window head height cannot receive direct daylight from the sun or the sky.

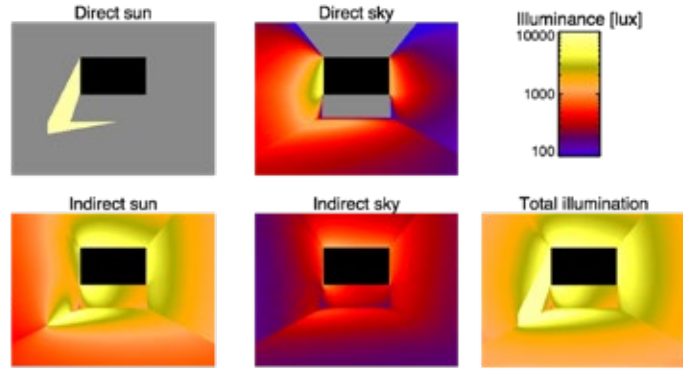

DIAGRAM: JOHN MARDALJEVIC
INSTITUTE OF ENERGY AND SUSTAINABLE
DEVELOPMENT, DE MONTFORT UNIVERSITY

FIGURE 59 Daylight simulation results showing the contribution of the direct and reflected sun and sky components on the brightness of interior surfaces.

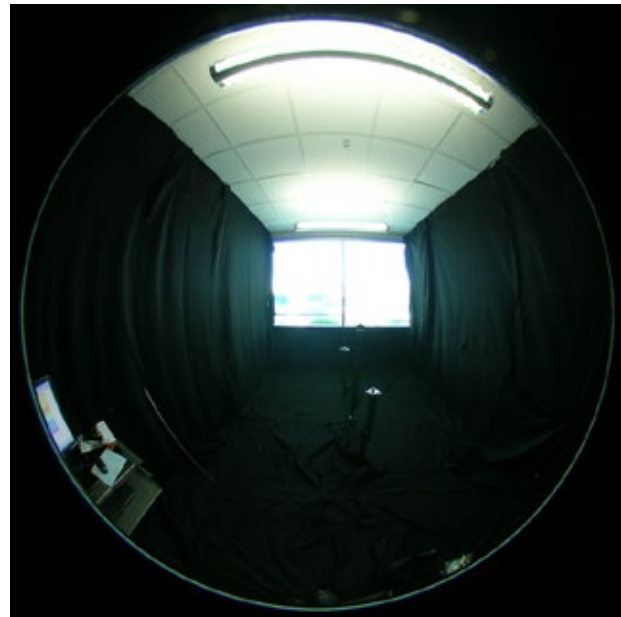
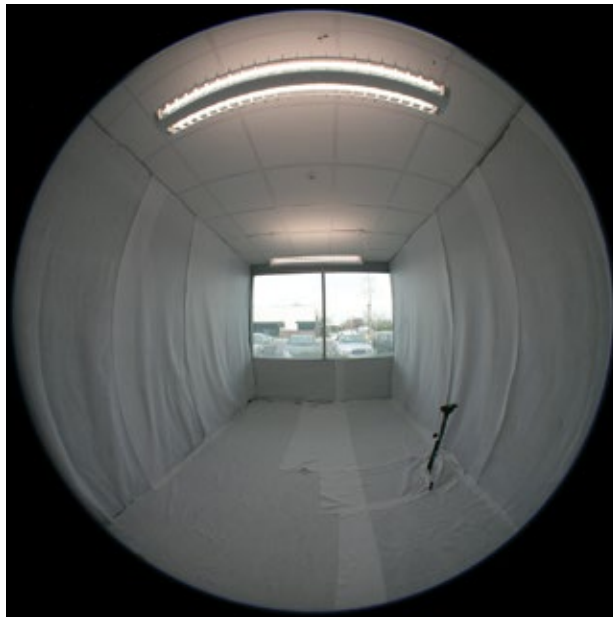

PHOTO: CLTC, UC DAVIS

FIGURE 60 Photographs of the same space with white cloth (left) and black cloth (right) on the floor and side walls. The work plane illuminance from the electric lighting meets the minimum requirements for office spaces in both cases, while the luminous environments are dramatically different, demonstrating the need for consideration of luminance (objective brightness) distributions in addition to meeting illuminance standards for effective daylight performance.

ARRANGEMENT OF FURNITURE

In addition to the reflectance of their surfaces, furniture can significantly affect daylight performance by its geometry and placement, especially in spaces illuminated by windows.

The lower the height of the furniture, the deeper the daylight penetration in the space. If high vertical elements, such as partitions, are required, they should be oriented perpendicular to the window wall to allow direct daylight to penetrate deeper into the space. Higher partitions can perform pretty well if they include light transmitting materials, which can have diffuse transmittance to maintain visual privacy while propagating daylight through the space (FIGURE 61).

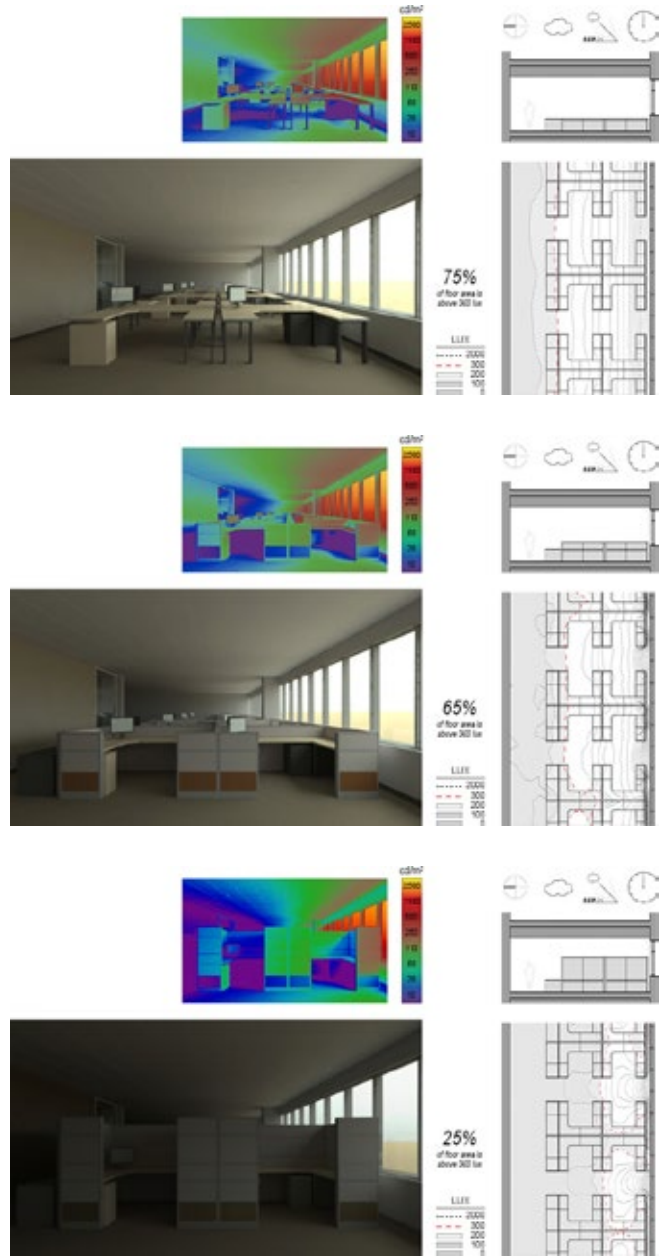

FIGURE 61 Series of computer-simulated renderings showing the effect of furniture on daylight performance under overcast skies.

DIAGRAM: DAYLIGHTING PATTERN GUIDE
NEW BUILDINGS INSTITUTE



ISTOCK.COM/ZHUDIFENG

ELECTRIC LIGHTING

GUIDELINES

This section of the daylighting guidelines is focused on electric lighting design considerations that are directly related to daylight harvesting. For extensive information on electric lighting design, please see the publication titled **“Nonresidential Lighting and Electrical Power Distribution—A Guide to Meeting or Exceeding California’s 2016 Building Energy Efficiency Standards”**.

AMBIENT & TASK LIGHTING

Interior lighting design usually includes consideration of different layers of light that address different lighting needs, such as ambient lighting, task lighting, accent/display lighting, and decorative/ornamental lighting. Daylight harvesting is usually focused on work-space ambient and task lighting layers, which have been traditionally combined and provided by ceiling-mounted recessed and/or pendant luminaires.

The task-ambient strategy for increased lighting energy efficiency is based on the separation of the ambient and task lighting layers, using ceiling mounted luminaires to provide ambient lighting and providing task lighting at workstations. This strategy is very effective in saving energy, as task lighting at the workstation can provide better illumination in terms of intensity and direction at a fraction of the power of providing task lighting throughout the space with ceiling-mounted luminaires. In such cases, daylight harvesting is addressing only the ambient illumination, which can be completely replaced by daylighting during most daytime work periods in daylit spaces.

ENERGY STANDARDS

The Energy Standards include mandatory and prescriptive requirements for electric lighting.

MANDATORY REQUIREMENTS

Mandatory requirements define the controls that must be installed in new construction projects. Five mandatory lighting control strategies are required by the Standards, including automated controls for daylight harvesting (**Section 130.1(d)**).

1. **Area Controls:** Manual controls that control lighting in each area separately (**130.1(a)**)
2. **Multi-level Controls:** “Dimmability” Allow occupants to choose the appropriate light level for each area (**130.1(b)**)
3. **Shut-off Controls:** Automatically shut off lighting or reduce light levels when illumination is not needed (**130.1(c)**)
4. **Automatic Daylighting Controls:** Adjust electric lighting in response to the presence of daylight (**130.1(d)**)
5. **Automated Demand Response:** Receive and automatically respond to demand response (DR) signals (**130.1(e)**)

CONTINUED ON PAGE 61

ENERGY STANDARDS

IES Handbook, 10th Edition

The IES recommended task illuminance range for most work space environments, such as office and school spaces, is from 30 to 50 footcandles (fc), depending on task size and contrast.



The IES recommended task illuminance range for most work space environments, such as office and school spaces, is from 30 to 50 footcandles (fc), depending on task size and contrast. Ambient light levels are much lower and can be entirely covered by daylighting during most daytime hours.

Daylight harvesting is most effective in areas under skylights and close to windows and clerestories, where it can satisfy most of the ambient and, often, task lighting requirements. Skylights can provide adequate illumination in the areas directly below them and surrounding floor area, depending on ceiling height, skylight well and glazing. Window and clerestories can provide significant illumination to replace ambient and most of task lighting needs in the areas adjacent to them, up to a distance of two window or clerestory head-heights.

LUMINAIRE PLACEMENT

The arrangement and grouping of luminaires for the purposes of controlling them for daylight harvesting are very important, as they have a significant effect on realizing potential savings from the strategy. In skylight applications, luminaires are usually mounted between skylights and are usually controlled in groups defined by lighting needs, rather than proximity to skylights, as usually daylight levels are relatively uniform across skylit areas. In window and clerestory applications, luminaires are usually laid out in individually controlled groups parallel to window walls, as daylight levels drop significantly by distance from windows and clerestories (**FIGURE 62** and **FIGURE 63**).

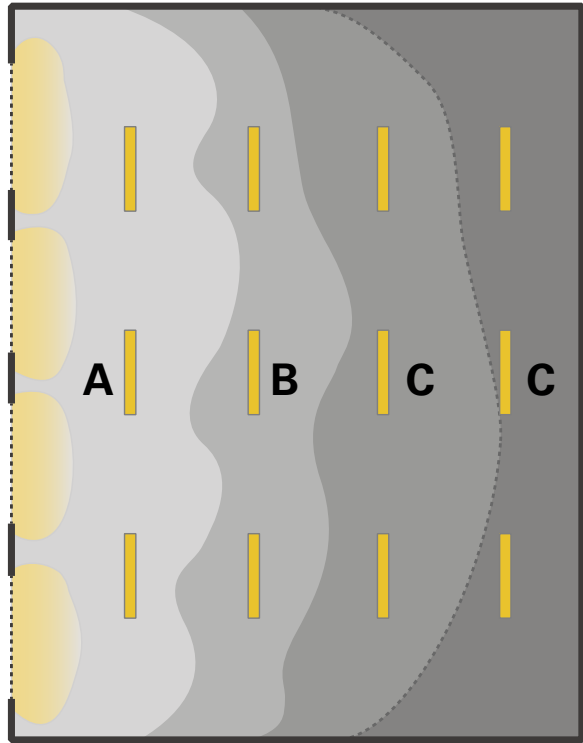
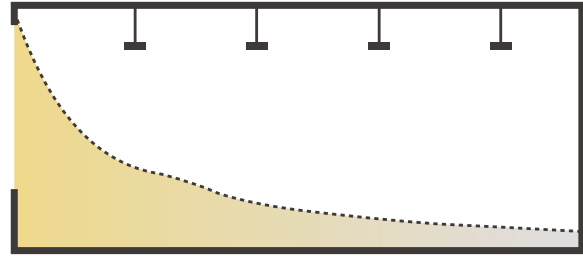

REPRODUCED BY CLTC. UC DAVIS ORIGINAL SOURCE UNKNOWN

FIGURE 62 Schematic drawing showing layout of electric lighting luminaires parallel to the window wall and organized in three groups that are controlled individually to effectively account for available daylight levels, which drop significantly as the distance from the window wall is increasing.

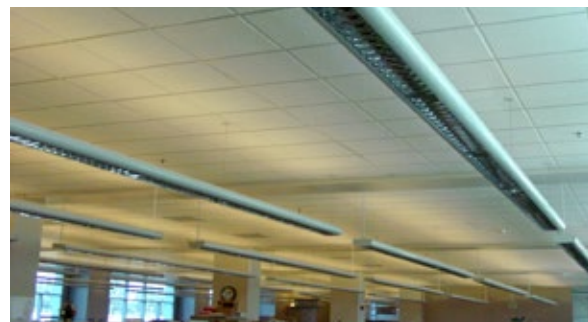

ORIGINAL SOURCE UNKNOWN SACRAMENTO MUNICIPAL UTILITY DISTRICT (SMUD) BUILDING, SACRAMENTO, CA

FIGURE 63 Photograph of an open office showing electric lighting luminaires laid out in groups parallel to the window wall and controlled individually to different dimming levels based on their distance from the window walls.

LIGHTING CONTROLS FOR DAYLIGHT HARVESTING

Lighting controls for daylight harvesting refer to control output of electric lighting based on available daylight.

CONTROLLING THE OUTPUT OF ELECTRIC LIGHTING

Controlling electric lighting output in work spaces used to be challenging and expensive with fluorescent and high-intensity discharge light sources, which cannot be easily dimmed or even switched quickly. They were especially bad at turning on at low intensity if they were dimmable. The new LED light sources have resolved this issue, as they can be dimmed very effectively from off through full output. Traditionally, electric lighting control strategies included on/off switching, stepped switching, stepped dimming, and continuous dimming.

ON/OFF AND STEPPED SWITCHING

On/off switching refers to turning all electric lighting on and off, while stepped switching refers to turning off only specific luminaires, or specific lamps within luminaires. There are two main disadvantages of on/off and stepped switching controls. The first disadvantage is the relatively large change in overall light levels, which is immediately perceived during electric lighting reduction, especially with on/off controls and stepped switching with one or two large steps between on and off. The second disadvantage is the change in the illuminance distribution across the space that results from turning off individual luminaires or individual lamps within each luminaire.

STEPPED AND CONTINUOUS DIMMING

Stepped dimming refers to adjusting all electric lighting output in steps, which is similar to stepped switching but now controlling the output of all electric lighting luminaires in the same way, which maintains relative illuminance distributions. The perceived change in illumination levels depends on the number of steps between full and minimum

PRESCRIPTIVE AND PERFORMANCE APPROACHES

The prescriptive approach defines the lighting power requirements. The Energy Standards offer multiple compliance paths for electric lighting systems: complete building method, area category method and tailored method. The performance approach is based on whole building design using software approved by the California Energy Commission.

For more information about the prescriptive and performance approaches, refer to **“Nonresidential Lighting and Electrical Power Distribution—A Guide to Meeting or Exceeding California’s 2016 Building Energy Efficiency Standards”**.

ELECTRIC LIGHTING CONTROLS FOR DAYLIGHT HARVESTING

The 2016 Building Energy Efficiency Standards require electric lighting controls enabling daylight harvesting to be installed in all daylit zones (defined on the next page) where there is at least:

- 0.3 Watts per square foot of lighting power
- 120 watts of electric lighting being used for general illumination
- 24 ft² of glazing

CONTINUED ON PAGE 62



2016 Building Energy Efficiency Standards Approved Computer Compliance Programs

The California Energy Commission has approved energy analysis software authorized to be used under the performance approach method of compliance for the 2016 Energy Standards.

Visit www.energy.ca.gov/title24/2016standards/2016_computer_prog_list.html for more information.

output of electric lighting. Continuous dimming is the equivalent of stepped dimming with at least ten steps between full output and off states.

Some on/off and stepped switching/dimming approaches also use a ramping function to gradually adjust light output from one step to the next. Spreading the ramping function over long periods of time makes it hard to perceive electric light output changes, as it provides time for the human vision to adjust to the changing light levels.

With the advent of solid-state lighting (SSL), most of the traditional electric lighting challenges have been resolved, as SSL can be easily dimmed across the whole range of its output. Considering the fact that SSL has become today's baseline technology for work-space lighting, these guidelines focus on continuous dimming controls.

SWITCH-TO-OFF VS DIM-TO-LOW

Traditionally, fluorescent lamps were not turned completely off, even during times that daylight exceeded required light levels, because it was difficult to effectively turn them back on at low light levels. Rather, they were dimmed to the lowest level they could reach without flickering. Today's SSL light sources can be effectively dimmed up and down across their whole output range and can easily support switch-to-off operation to maximize energy savings. However, building occupants that are not familiar or aware of daylight harvesting controls often get confused when electric lights are turned off automatically and either call the facility manager to report a malfunction, or override the system by turning electric lights on manually, eliminating electric lighting savings. Unless occupants are educated and aware of electric lighting controls for daylight harvesting, it may be best to dim-to-low rather than to switch-to-off, to avoid confusion and potential elimination of lighting savings.

When the electric lighting controls detect that daylight illuminance equals at least 150 percent of the designed illuminance from the electric lighting when measured at the task plane, the general lighting power in that daylit zone must be reduced by at least 65 percent of full power.

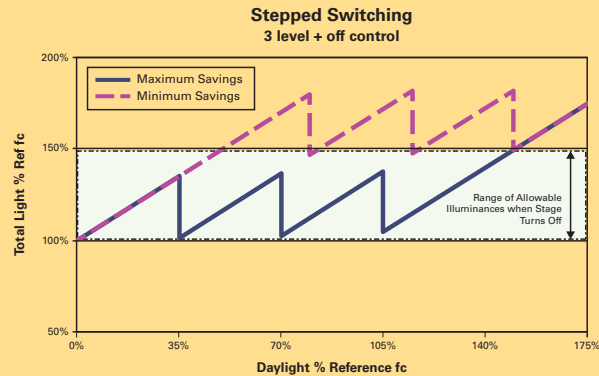

REPRODUCED BY CLTC, UC DAVIS
 ORIG. SOURCE: CALIFORNIA ENERGY COMMISSION

FIGURE 64 Example of stepped switching automatic daylighting controls showing the daylit and electric lighting contribution to total footcandles in the y-axis and daylight contribution only in the x-axis.

DAYLIT ZONES

Daylit zones are determined according to methods defined in the Building Energy Efficiency Standards.

Daylit Zones are areas within a building where daylight harvesting is possible due to their close proximity to daylight apertures. There are three types of daylit zones: Primary Sidelit Daylit Zone, Secondary Sidelit Daylit Zone, and Skylit Daylit Zone.

- **Primary Sidelit Daylit Zone:** Daylit area directly adjacent to one or more windows
- **Secondary Sidelit Daylit Zone:** Daylit area not directly adjacent to a window that still receives some daylight through its proximity of the window
- **Skylit Daylit Zone:** Daylit area illuminated by one or more skylight

CONTINUED ON PAGE 65

DETERMINING DAYLIT ZONES

All skylit daylight zones and primary sidelit daylight zones must be shown on building plans. Secondary sidelit daylight zones must also be shown on the plans when complying with prescriptive requirements for automatic daylighting controls in secondary sidelit daylight zones. The easiest way to determine the size of daylight zones is examining building plans.

CALCULATING A SKYLIT ZONE

1. **Define the shape of the skylight.** A rectangular skylight produces a rectangular daylight zone, and a circular skylight produces a circular zone, etc.
2. **Determine the average ceiling height (CH) surrounding the skylight.** The ceiling height is the vertical distance from the finished floor level to the ceiling.
3. **Multiply the CH by 0.7.**
4. **Add the value determined in Step 3 in all directions around the skylight** (starting at the edges of the opening).
5. Subtract any area blocked from receiving daylight by a permanent obstruction taller than half the distance from the floor to the bottom of the skylight.

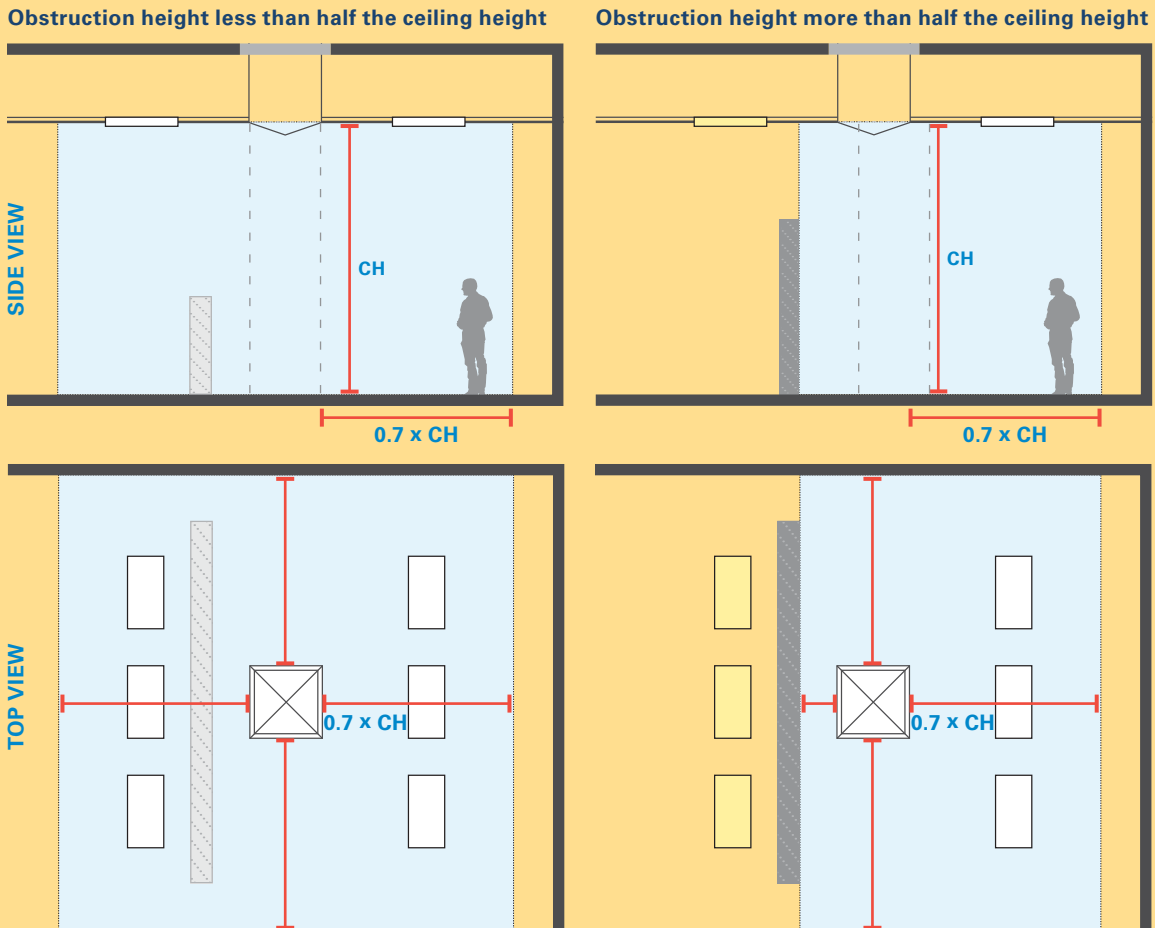

FIGURE 65 Example electric lighting and daylighting design used to show how to calculate a skylit zone with varying obstruction heights.

REPRODUCED BY CLTC, UC DAVIS
ORIG. SOURCE: CALIFORNIA ENERGY COMMISSION

CALCULATING A PRIMARY SIDELIT ZONE

1. **Determine the window head height for each window.** The window head height (WHH) is the vertical distance from the finished floor level to the top of the glazing.
2. **Determine the depth of the zone.** The zone depth is one window head height into the area adjacent to the window.
3. **Calculate the width of the zone.** The zone width is the window's width added to half the window head height on each side of the window.
4. Subtract any area blocked from receiving daylight by a permanent obstruction that is six feet or taller. Modular furniture is not considered a permanent obstruction.

REPRODUCED BY CLTC, UC DAVIS
 ORIG. SOURCE: CALIFORNIA ENERGY COMMISSION

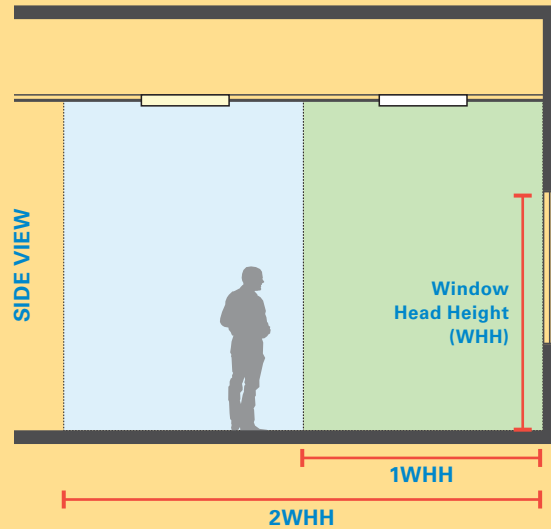

FIGURE 66 Example electric lighting and daylighting design used to show how to calculate a primary sidelit zone.

CALCULATING A SECONDARY SIDELIT DAYLIT ZONE

A secondary sidelit daylit zone extends one additional window head height beyond the primary sidelit daylit zone(s) adjacent to it.

1. Add one additional window head height to the same dimensions determined for primary sidelit daylit zones, to determine the depth and width of the secondary sidelit daylit zone.
2. Subtract any area that is blocked from receiving daylight by a permanent obstruction that is 6 feet or taller.

REPRODUCED BY CLTC, UC DAVIS
 ORIG. SOURCE: CALIFORNIA ENERGY COMMISSION

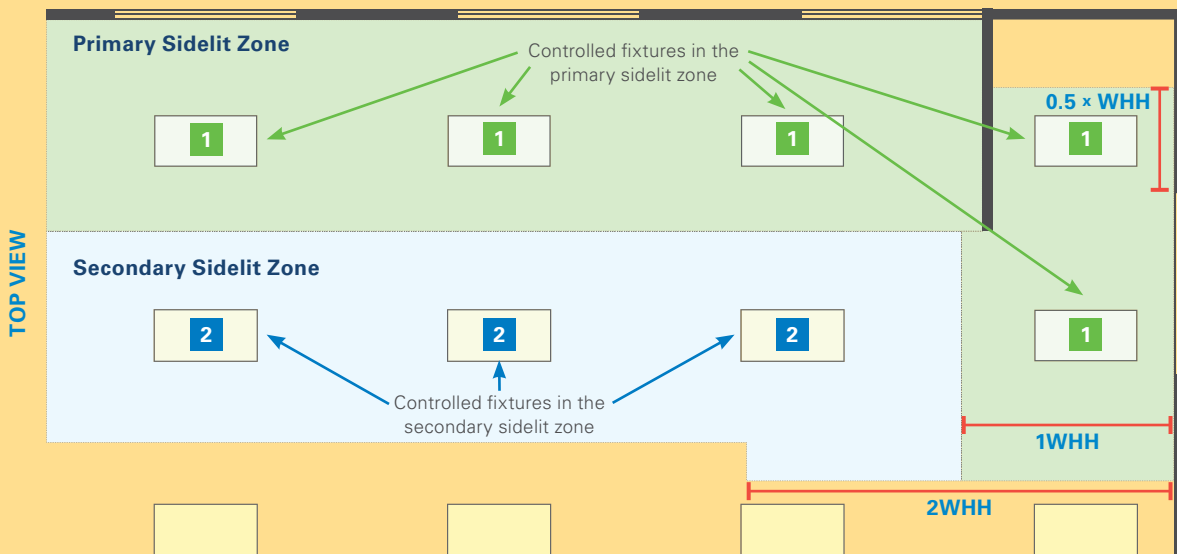

FIGURE 67 Example electric lighting and daylighting design used to show how to calculate a primary and secondary sidelit zone with a permanent obstruction that is 6 feet.



DETERMINING AVAILABLE DAYLIGHT

Determining available daylight has been, and still is, a key challenge in controlling electric lighting as part of a daylight harvesting strategy. Traditionally, there have been two main strategies to determine daylight levels: time and photosensing.

ASTRONOMICAL TIME CLOCKS

Astronomical time clocks are ordinary clocks that also include information about sunrise and sunset times for the building location. They are very easy and economical to use for switching or dimming electric lights at specified times. Set points are based on sunrise and sunset times, which change through the year.

The main disadvantage of time-based controls is the lack of information about sky conditions, including cloud coverage, and external obstructions, which can greatly affect daylight penetration through building apertures. The solution to this shortcoming is the addition of a photosensor to help determine sky conditions.

Daylit zones must be marked on building floor plans.

Daylit zones must have daylighting controls. Daylighting control sensors must be located so that they are not readily accessible to unauthorized personnel. Additionally, lighting in daylit zones should have multi-level steps, per **Table 130.1-A** if the lighting power density is 0.3 Watts per square foot or greater. Combined illuminance, from daylight and electric light, should not be less than the designed illuminance or more than 150 percent of the design illuminance. When daylight illuminance is greater than 150 percent of the design illuminance, controls must reduce lighting power by at least 65 percent. A power adjustment factor (PAF) of 10 percent can be applied to the luminaires in skylit daylit zones or primary sidelit daylit zones where the electric lighting is commissioned to turn off completely.

The prescriptive compliance approach for a space requires that mandatory automatic daylighting controls also apply to general-lighting luminaires that are at least 50% in a secondary sidelit daylit zone.

CONTINUED ON PAGE 66



ALTERATIONS

Alterations with proposed lighting power greater than 85 percent of the allowed lighting power are required to adhere to the Automatic Daylight Control requirements defined in **Section 130.1(d)**.

Alterations with proposed lighting power that is 85 percent or less of the allowed lighting power do not need to meet the automatic daylighting control requirements defined in **Section 130.1(d)**.

A compliance option is available for alterations where existing luminaires are replaced with new luminaires and do not include adding, removing or replacing walls or ceilings. For these types of alterations in hotels, offices and retail spaces, replacement luminaires that reduce the existing lighting power by at least 50 percent do not need to meet automatic daylighting control requirements defined in **Section 130.1(d)**. For these types of alterations in all other spaces, replacement luminaires that reduce existing lighting power by at least 35 percent do not need to meet the automatic daylighting control requirements defined in **Section 130.1(d)**.

ADDITIONS

Projects adding square footage are considered new construction and must meet Energy Standards requirements. Lighting plans for building additions must meet the same mandatory and prescriptive or performance standards as lighting installed for a new construction project. If the performance approach is followed, the lighting power for the general lighting systems may be traded off with other building features.

PHOTOSENSING

Photosensing refers to using one or more photosensors to determine available daylight. While it sounds straightforward, it is in fact, very challenging and even today, the challenge has not been entirely resolved. The main components of photosensor-based controls are one or more photosensors and a logic controller, which receives, as input, the signal(s) of the photo sensor(s) and sends, as output, a signal to the power controller of the electric lighting. Power controllers include the dimming ballast for fluorescent and HID sources and dimming drivers for SSL sources.

Photosensors can vary significantly in terms of spectral and directional sensitivity, both of which are most important for effective sensing of available daylight. The spectral power sensitivity depends on the light sensing technology of the photosensor and ideally should match human Photopic sensitivity (FIGURE 68). The directional sensitivity depends on the optical elements of the photosensor that direct the incident light towards the light sensitive element (FIGURE 69).

Traditionally, there have been two main photosensing strategies: open- and closed-loop sensing.

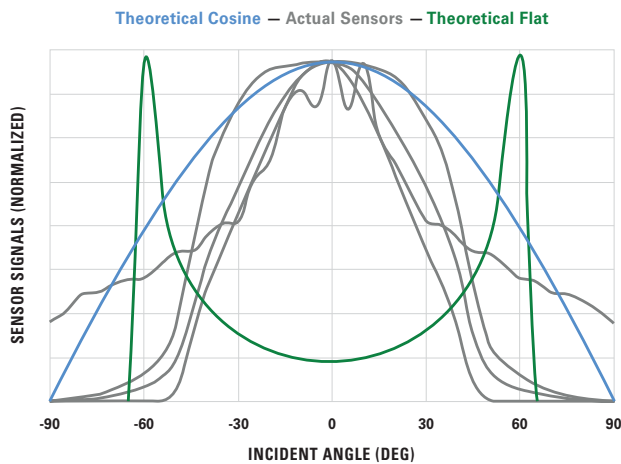

FIGURE 69 Directional sensitivity of various commercially available photo sensors, along with a cosine response, where the sensitivity drops by the cosine of the incident angle, and a “flat” response, which is a computed sensitivity aimed at producing the same signal from all incoming directions within a confined field of view (FOV).

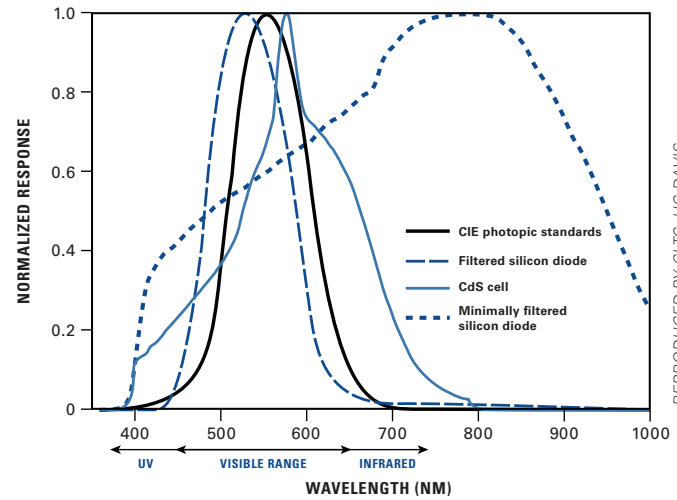

FIGURE 68 Spectral sensitivity of different light sensing technologies, along with the human Photopic sensitivity standard. Photo sensors that deviate from the Photopic sensitivity, such as those that use a minimally filtered silicon diode, can be unreliable, as their signal is affected by non-visible radiation.

REPRODUCED BY CLTC, UC DAVIS
ORIG. SOURCE: LIGHTING RESEARCH CENTER
RENSSELAER POLYTECHNIC INSTITUTE

OPEN-LOOP SENSING

In open-loop sensing, the signal of the photosensor used to determine daylight levels is not affected by the electric lighting being controlled. Open-loop photosensing has been traditionally implemented with photosensors placed either outdoors, aimed towards the sky, or indoors, aimed towards windows or skylights with their field of view (FOV) limited to outdoor surfaces through the windows or skylights (FIGURE 70). Open loop sensing usually requires photosensors with extensive range to capture the high outdoor daylight levels, which vary dramatically from 1 fc in the beginning and the end of the day, to more than 10,000 fc under mid-day clear sky conditions. The main disadvantage of open-loop sensing is that it does not reflect indoor daylight levels and often results in over-dimming, as outdoor daylight levels usually increase very rapidly to high levels, making it hard to map on the relatively small range of low levels indoor by both electric and daylight.

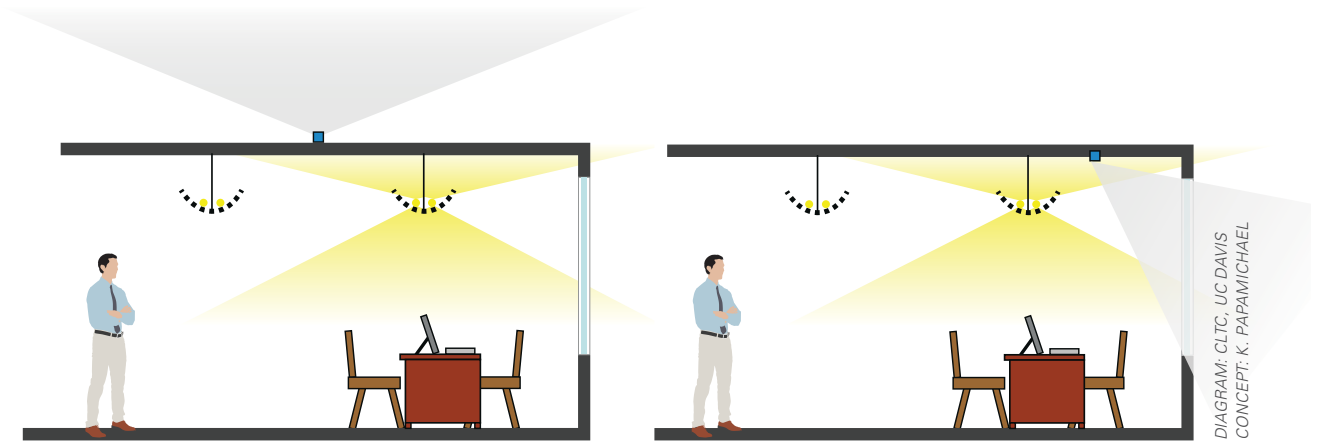

FIGURE 70 Schematic drawings showing placement and field of view of photo sensors for open-loop photo sensing.

DIAGRAM: CLTC, UC DAVIS
CONCEPT: K. PAPAMICHAEL

CLOSED-LOOP SENSING

In closed-loop sensing, the signal of the photo sensor used to determine daylight levels is affected by the electric lighting being controlled. Closed-loop photo sensing has been traditionally implemented with photo sensors that are placed indoors, aimed away from daylight apertures (FIGURE 71). Photo sensor placement and direction/field of view are the most challenging decisions in closed-loop photo sensing. Ideally, closed loop photo

sensors should be placed and oriented so that their signal is equally affected by daylight and electric light. Unbalanced contributions can be ineffective in sensing either daylight changes or electric light changes (FIGURE 72), since their field of view includes interior surfaces that are equally affected by electric light and daylight, which requires significant understanding of how daylight affects the brightness of interior surfaces throughout the year for different locations and window/clerestory orientation.

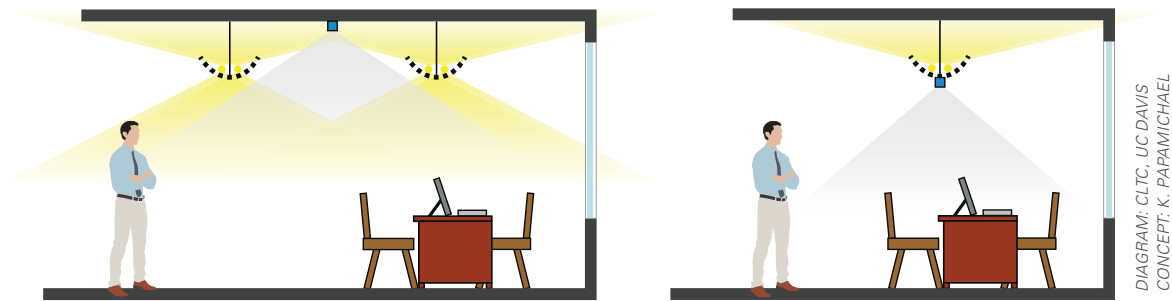

FIGURE 71 Schematic drawings showing placement and field of view of photo sensors for closed-loop photo sensing.

DIAGRAM: CLTC, UC DAVIS
CONCEPT: K. PAPAMICHAEL

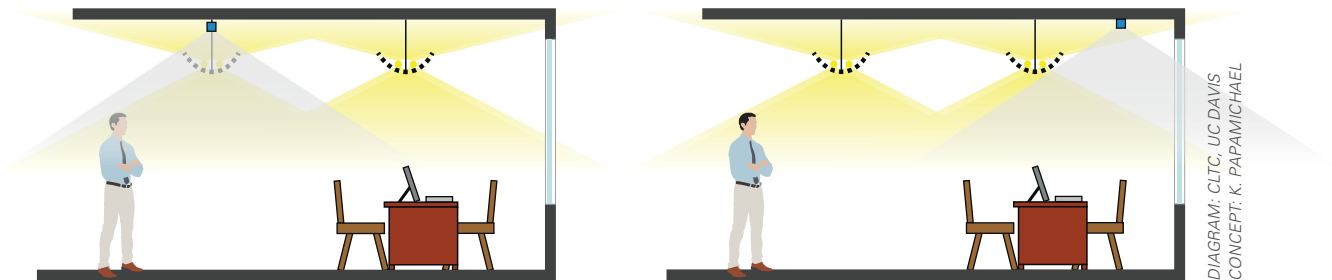

FIGURE 72 Schematic drawings showing ineffective placement of photo sensors that result in unreliable sensing of daylight changes (left) and electric lighting (right).

DIAGRAM: CLTC, UC DAVIS
CONCEPT: K. PAPAMICHAEL

CONTROL ALGORITHMS

Both open- and closed-loop approaches use algorithms, which are executed by the logic controller. These algorithms take, as input, photosensor signals to determine daylight changes and the appropriate signal that is sent as output to the electric lighting power controller(s), which, in turn, adjusts the dimming level of the electric lighting (FIGURE 73). Power controllers use internal functions that map lamp output to supplied power (FIGURE 74).

There are two main algorithmic approaches that have been traditionally used to translate photosensor signals into signals that are sent to the power controller that manages the electric lighting output. The first is the constant set point, or threshold algorithm, and the second is the sliding set point, or proportional algorithm. Both approaches require commissioning, which is the process of installing and configuring the overall control system on site. This includes photosensor placement and determination of key values for control parameters that customize the operation of the control system for the specific application. For more information, please see the commissioning section of this guide.

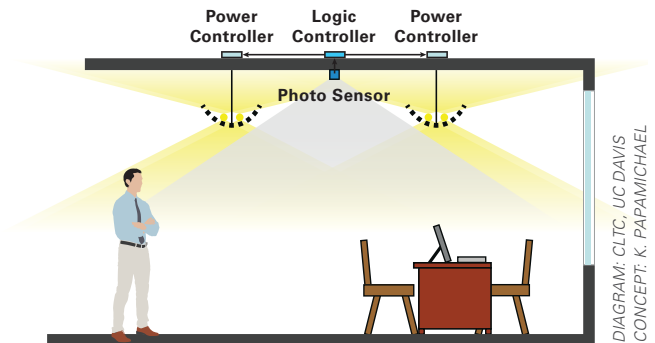

DIAGRAM: CLTC, UC DAVIS
CONCEPT: K. PAPAMICHAEL

FIGURE 73 Schematic drawing showing the components of photo sensor based controls for daylight harvesting.

CONSTANT SET POINT ALGORITHMS

The constant set point algorithm is applicable only to closed-loop sensing approaches and aims at adjusting electric lighting levels to maintain a specific photosensor signal, which is set during the commissioning of the control system, on site, and is referred to as the set point. The set point must be equal to or higher than the sensor signal from the electric lighting at full output, excluding contributions from daylighting. This signal can be determined effectively during night time with the electric lighting at full output. It can also be

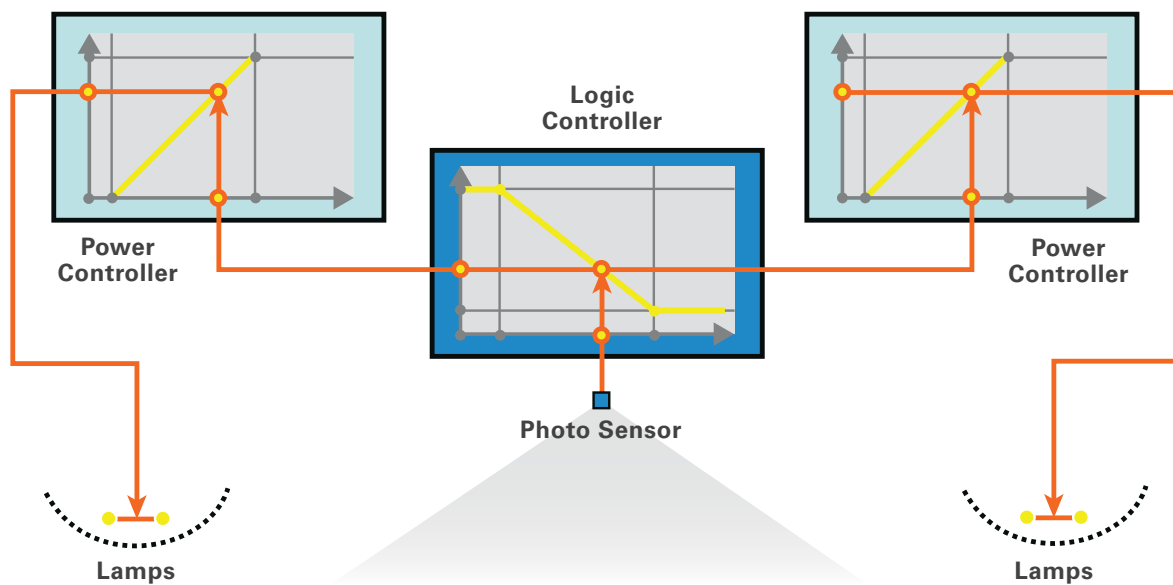
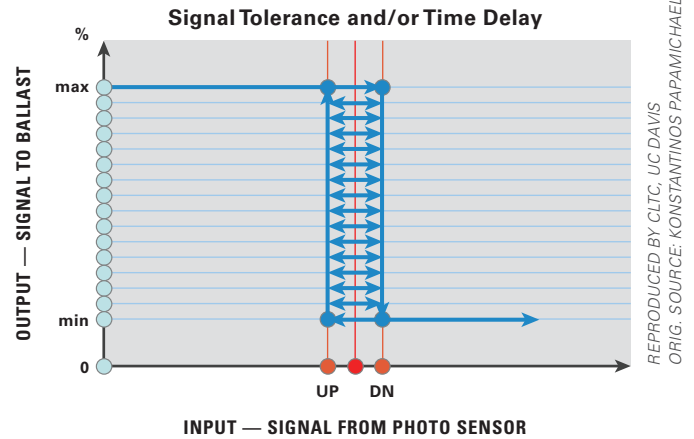

DIAGRAM: KONSTANTINOS PAPAMICHAEL

FIGURE 74 Schematic drawing showing the translation of the photosensor signal into a dimming signal to power controllers, which in turn translate that signal to power delivered to from the lamps.

approximated during daytime, as the difference of the photosensor signal produced by turning the electric lighting on and off.

There are two common approaches to maintaining the constant set point with somewhat similar outcome (FIGURE 75). The first is based on setting a time delay before sending a signal to the power controller after the signal of the photo sensor deviates from the Set Point. The second approach is based on setting a range encompassing the Set Point, defining the maximum allowable deviation above and below the Set Point. After the time delay of the signal being below or above the set point (first approach) or when the photo sensor signal reaches the lower or higher points of the range (second approach), the logic controller sends "dim up" or "dim down" signals, respectively, to the power controller(s) of the electric lighting system. Specific signals to power controllers depend on the lighting control protocol used. FIGURE 76 shows measured responses of Constant Set Point algorithms of commercial



REPRODUCED BY CLTC, UC DAVIS
ORIG. SOURCE: KONSTANTINOS PAPAMICHAEL

FIGURE 75 Schematic diagram showing the operation of typical Constant Set Point algorithms, which is realized either by setting a time-delay before taking action after a deviation of the photo sensor signal from the Set Point, or by setting a range that defines the maximum allowable deviation from the Set Point.

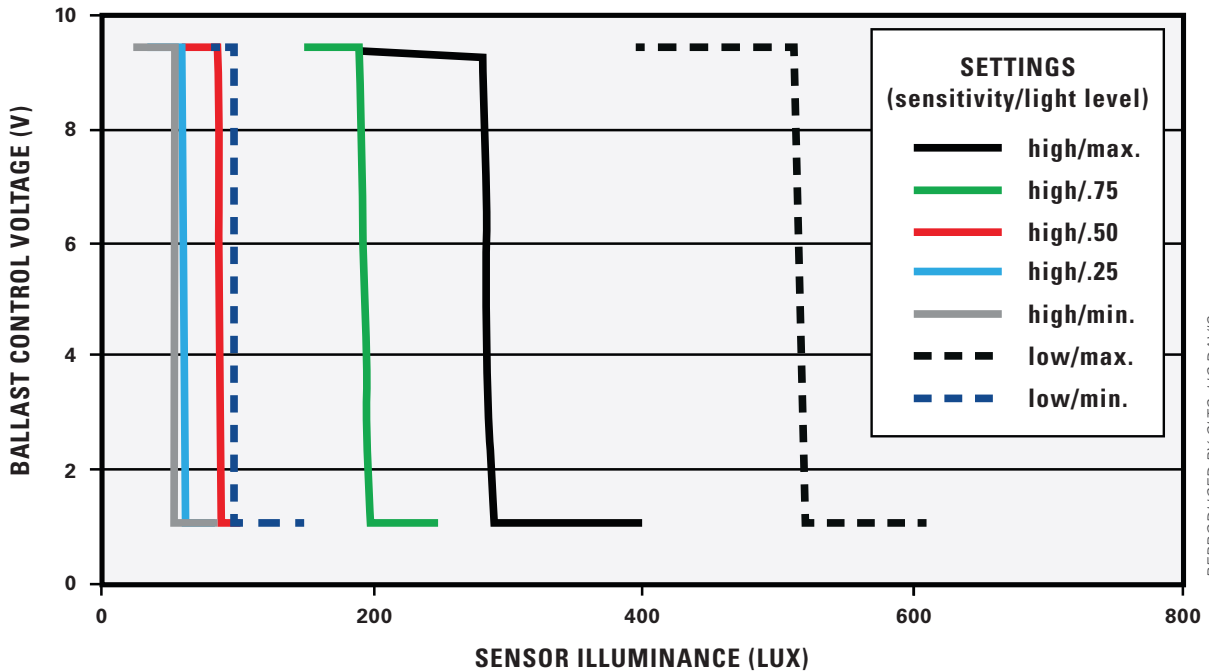

REPRODUCED BY CLTC, UC DAVIS
ORIG. SOURCE: LIGHTING RESEARCH CENTER
RENSSELAER POLYTECHNIC INSTITUTE

FIGURE 76 Examples of Constant Set Point algorithms at different sensitivity and light level combinations.

systems, producing 0-10 Volt output signals, which is a widely used control protocol. For more information on lighting control protocols, please see the publication **“Nonresidential Lighting and Electrical Power Distribution—A Guide to Meeting or Exceeding California’s 2016 Building Energy Efficiency Standards”**.

SLIDING SET POINT ALGORITHM

The Sliding Set Point algorithm is applicable to both closed- and open-loop sensing approaches and generates an output to the power controller(s) that is proportional to the signal of the photo sensor, between a range defined by an Offset Point and a Sliding Set Point, both of which are determined during the commissioning process, on site (FIGURE 77).

SHORTCOMINGS OF SINGLE PHOTSENSOR APPROACHES

Both open- and closed-loop photo sensing approaches have advantages and disadvantages in terms of reliable sensing of daylight changes and cost associated with commissioning. The challenges of photosensing approaches are mostly evident during sunrise, sunset and partly cloudy sky periods, when daylight changes occur. Partly cloudy skies are the most challenging, as daylight changes can be dramatic as clouds pass in front of the sun, blocking direct sunlight.

The main disadvantage of open-loop, single photosensor approaches is the rapid change of outdoor light levels during sunrise and sunset periods, which is usually not reflected indoors

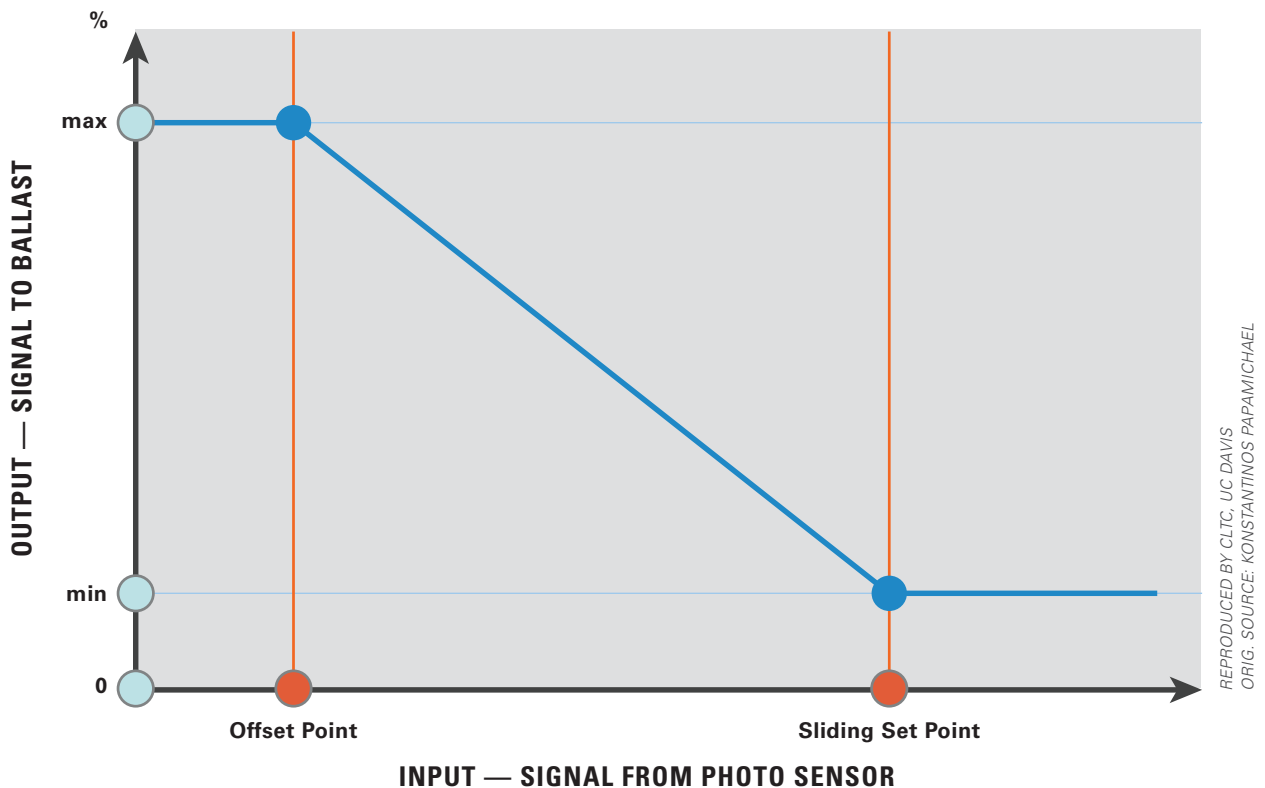

FIGURE 77 Schematic drawing showing the operation of typical Sliding Set Point algorithms, where the signal to the power controller is proportional to the photo sensor signal, with the proportionality relationship managed through a sliding set point.

(FIGURE 78). The dramatic open-loop changes during sunrise and sunset result in fast-paced dimming, and over-dimming of the electric lighting system, which results in periods with lower than desired overall illuminance levels.

The main disadvantage of closed-loop, single photosensor approaches is the inability to differentiate between signal changes caused by daylight changes and signal changes caused by changes in the geometry and/or reflectance of the surfaces within the field of view of the sensor. The latter includes changes in floors, walls and furniture, but also occupants moving within the sensor's field of view. In long-term space changes, such as changes to interior surface color or texture and/or furniture arrangement, both open- and closed-loop systems need to be recommissioning to reflect the space changes, adding to the cost of maintaining the system, as commissioning requires significant understanding of daylighting fundamentals and principles and also extensive experience.

A common approach to addressing short-term changes, such as occupants with different colors of clothing passing under photo sensors, is to include a time-delay in the algorithms before taking action, hoping that within the time-delay period the person(s) will have passed and the signal of the photo sensor will return to its previous level. This, of course, raises the issue of the length of the time delay. Short time-delays will not be able to account for low speed person movement, while long-time delays increase the risk of ignoring a true daylight change, such as the sun blocked by passing clouds. The latter produces a dramatic change in indoor light levels, which is certainly perceived by occupants. Without immediate adjustment to the electric lighting output, occupants often consider the system ineffective and occasionally disable it, which can be easily done by covering the photosensor with tape, keeping the electric lighting continuously on.

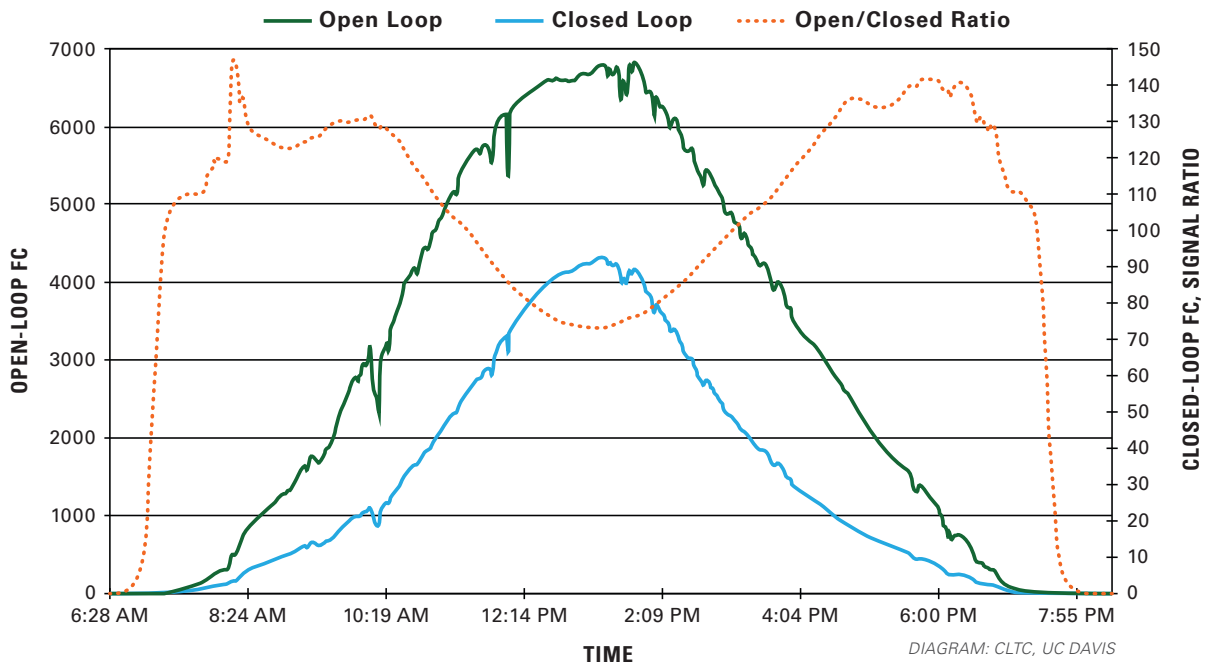

FIGURE 78 Measured photo sensor signals of open- and closed-loop sensing approaches and their ratio (open/closed loop). The open-loop sensing signal and open/closed ratio are measured on the left axis, with maximum values approaching 7,000 fc. The closed-loop sensing signal is measured on the right axis, with maximum values approaching 150 fc, i.e., the closed-loop line would be barely visible if it were plotted against the left axis. The open/closed loop ratio shows the two signals are not proportional, especially during the sunrise and sunset periods.

DUAL-LOOP & REDUNDANT PHOTO-SENSING APPROACHES

The realization of the shortcomings of open- and closed-loop sensing approaches has led to the development of the Dual-Loop and Redundant Sensing approaches. The Dual-Loop approach was originally developed for skylight applications and, as the name suggests, it uses both open- and closed-loop sensing to reliably determine true daylight changes (**FIGURE 79**). The closed-loop photosensor is used to monitor light levels in the space, while the open-loop photosensor is used to help determine if the change of the signal of the closed-loop photosensor was produced by daylight changes. Compared to open loop sensing for skylight applications, dual-loop has proven to be significantly more reliable, doubling the energy savings and eliminating complaints of low light levels during sunrise and sunset periods.

The dual-loop sensing approach can also be used in spaces with windows and clerestories. Moreover, a single open-loop photo sensor can be paired with multiple closed-loop photo sensors, to serve a whole building.

Redundant Sensing is equivalent to the dual-loop, but relies on the use of multiple closed-loop photosensors that collectively increase reliability of sensing daylight changes dramatically. Redundant sensing using luminaire integrated sensors may be the most reliable and cost-effective way to implement electric lighting controls for daylight harvesting.

Emerging dual-loop and redundant sensing technologies are expected to dramatically increase reliability and cost effectiveness of electric lighting controls. Combined with SSL dimming, these approaches seem to remove all of the traditional barriers to implementing effective electric lighting controls for daylight harvesting.

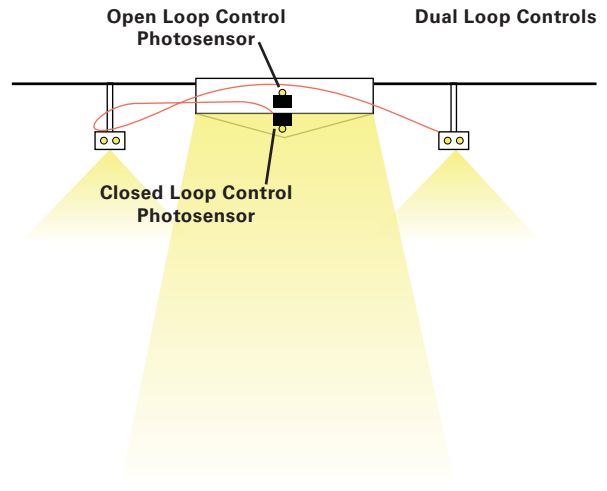
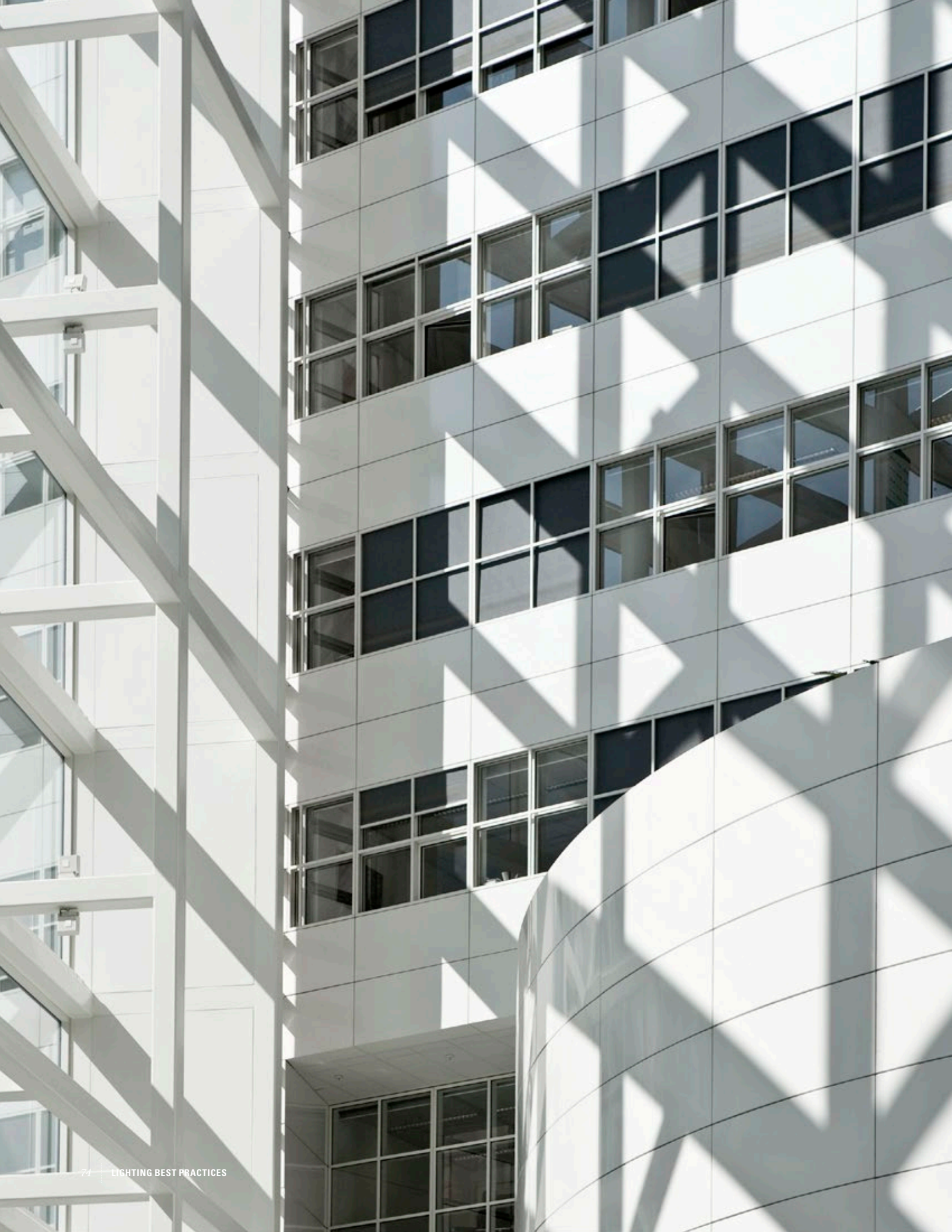
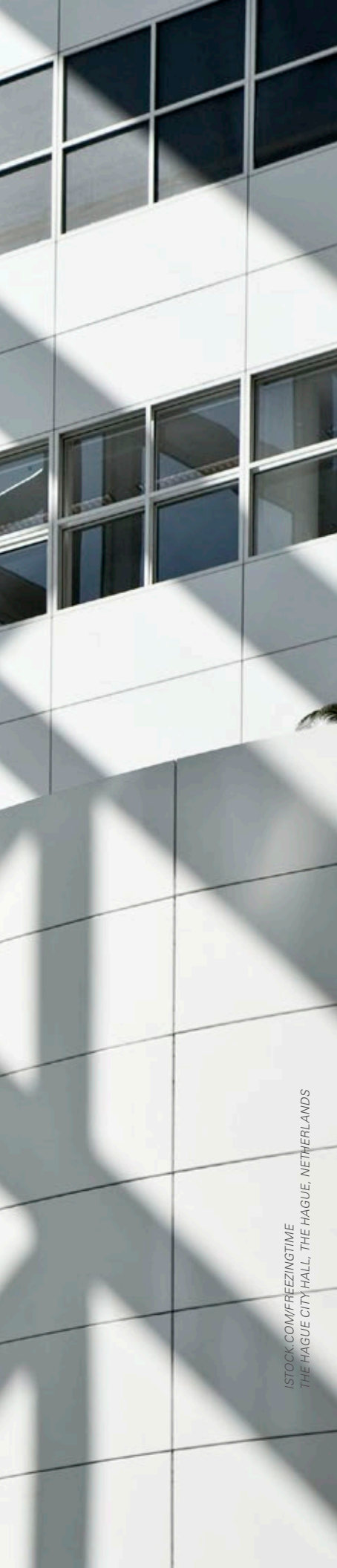

FIGURE 79 Schematic drawing showing dual-loop sensing approach in skylight applications.

DIAGRAM: CLTC, UC DAVIS
CONCEPT: K. PAPANICHAEL





ISTOCK.COM/FREEZINGTIME
THE HAGUE CITY HALL, THE HAGUE, NETHERLANDS

CHAPTER 4

CONSTRUCTION, COMMISSIONING & ACCEPTANCE TESTING

The design phase of a commercial building project with daylight harvesting is followed by the building construction, commissioning and acceptance testing phases. Each phase of the project is critical to realizing the full design intent for a high-performance building, and specifically for realizing a high-performance daylight harvesting system. To properly install and commission the building systems, it is important to use trained workforce for each specific building system, including structural, envelope, mechanical, electrical and information technology.

CONSTRUCTION



ISTOCK.COM/JANIFEST

COMMISSIONING



ISTOCK.COM/
SAMUELBROWNING

ACCEPTANCE TESTING



ISTOCK.COM/HIGHWAYSTARZ
PHOTOGRAPHY



CONSTRUCTION

During the design phase, it is critical to provide as much specificity in the building plans and documentation as possible to allow for the project team to fully realize the design intent. Additionally, it is recommended that the design team compile a 'design intent' document to detail the justification for each specified building component. This is especially important in instances where long timelines may preclude the procurement of a specific component. For instance, a component specified during the design phase may not be available at the time of installation, or the product part number may have been changed.

COMMISSIONING

The Energy Standards require specific building commissioning steps for new construction of commercial buildings. Additionally, lighting control systems must be tested after they are installed and commissioned. Tests ensure that controls operate in accordance with the Energy Standards and the building owners requirements. Functional test results must also be included in commissioning documents.

ELECTRIC LIGHTING

Generally, commissioning electric lighting controls for daylight harvesting involves several steps:

1. Verification of luminaire types, placement and grouping based on daylight zones
2. Verification of installation and proper operation of clocks and/or photo sensors
3. Adjustment of control parameters, such as photosensor set points for electric lighting dimming, time delays, etc.

ENERGY STANDARDS

For commercial new construction buildings with conditioned space of 10,000 square feet or more, the building design, construction, and commissioning processes are defined in [Section 120.8](#). This is broken down into the following standalone requirements:

Owner's or owner representative's project requirements (OPR): The energy-related expectations and requirements of the building.

Basis of design: A written explanation of how the design of the building systems and components meets the OPR shall be completed at the design phase of the building project.

Design phase design review: Mandatory design review kickoff meeting is required during the schematic design phase. The design review

CONTINUED ON PAGE 77

4. Verification for proper operation of lighting controls during daylight changes

The photo sensor signal depends on the geometry and reflectance of the surfaces within the field of view, and the directional sensitivity of the photosensor. Unless the photo-control system includes redundant sensing and automated calibration, it is important that the photo sensor is installed so that the surfaces within its field of view are not going to be changing often and can accept equal levels of electric lighting and daylighting.

The verification of proper operation is the ultimate commissioning step and is best performed during times of daylight changes, such as sunrise, sunset and partly cloudy daytime periods. It is important that the commissioning of the electric lighting system happens after the interior design of the daylit space has been completed, including furniture. The commissioning process should also include testing of the effect of occupants on photosensor signals to make sure it is minimal or properly handled by automated calibration.

FENESTRATION

Automated daylight management at the fenestration level is not yet widespread and there are no industry accepted commissioning requirements or procedures. As daylight management systems respond to glare and the status of the electric lighting and HVAC systems, commissioning of daylight management systems should address all of these control criteria to ensure proper operation under a wide-range of scenarios.

As daylight management usually involves significant occupant control for non-energy related functions, such as view and privacy, it is important that the commissioning process includes testing of the harmonization of automated and manual controls, testing for alternative scenarios of manual controls overriding the automated operation and eventually returning back to it.

Certificates of Compliance documents must be completed by the designated design reviewer who adheres to the reviewer requirements.

Commissioning measures shown in the construction documents: Complete descriptions of all measures or requirements necessary for commissioning shall be included by the design team in the construction documents (plans and specifications).

Commissioning plan: Prior to permit issuance a commissioning plan shall be completed to document how the project will be commissioned and shall be started during the design phase of the building project.

Functional performance testing: Functional performance tests shall demonstrate the correct installation and operation of each component, system and system-to-system interface in accordance with the acceptance test requirements.

Documentation and training: A Systems Manual and Systems Operations Training shall be completed.

Commissioning report: A complete report of commissioning process activities undertaken through the design, construction and reporting recommendations for post-construction phases of the building project shall be completed and provided to the owner or owner's representative

For commercial new construction buildings with conditioned space of less than 10,000 square feet, only the design review and commissioning measures shown in the construction documents requirements apply.



ISTOCK.COM/KATARZYNABIALASIEWICZ

ACCEPTANCE TESTING

For some building systems, additional function tests are required beyond commissioning, referred to as acceptance testing. Acceptance testing consists of visual inspection and functional performance tests of installed equipment, systems and controls. It was created to help increase code compliance by ensuring that lighting control systems are installed and operating correctly. Acceptance testing will identify any problems with the installation so that they can be corrected before the certificate of occupancy is issued. A properly functioning system saves energy, and ensures that building owners and tenants realize the full benefits of an optimized electrical lighting control system and daylighting control system.

2016 NRCA-LTI-03-A

The Automatic Daylighting Control Acceptance document is one of the compliance forms that must be completed by an acceptance tester.

To view and download compliance forms, visit www.energy.ca.gov/title24/2016standards.

<small>STATE OF CALIFORNIA</small> AUTOMATIC DAYLIGHTING CONTROL ACCEPTANCE DOCUMENT <small>CEC-NRCA-LTI-03-A (Revised 08/16)</small>		 <small>CALIFORNIA ENERGY COMMISSION</small>
CERTIFICATE OF ACCEPTANCE Automatic Daylighting Control Acceptance Document		NRCA-LTI-03-A (Page 1 of 11)
<small>Project Name:</small>	<small>Enforcement Agency:</small>	<small>Permit Number:</small>
<small>Project Address:</small>	<small>City:</small>	<small>Zip Code:</small>
<small>Note: Submit one Certificate of Acceptance for each system that must demonstrate compliance.</small>		<small>Enforcement Agency Use: Checked by/Date</small>
Check boxes for all pages of this NRCA-LTI-03-A completed and included in this submittal		
<input type="checkbox"/>	NRCA-LTI-03-A Page 1 & 2	Construction Inspection. This page required for all submittals.
<input type="checkbox"/>	NRCA-LTI-03-A Page 3 & 4	Continuous dimming control functional performance test – watt-meter or amp-meter measurement
<input type="checkbox"/>	NRCA-LTI-03-A Page 4 & 5	Stepped Switching/ Stepped Dimming functional performance test – watt-meter or amp-meter measurement
<input type="checkbox"/>	NRCA-LTI-03-A Page 7 & 8	Continuous dimming control functional performance test – light meter power measurement, and default look-up table of fraction of rated power versus fraction of rated light output.
<input type="checkbox"/>	NRCA-LTI-03-A Page 10 & 11	Stepped Switching/ Stepped Dimming functional performance test – based on light output

ACCEPTANCE TESTING (SECTION 130.4, NA 7.6)

The Building Energy Efficiency Standards require that all nonresidential, high-rise residential, and hotel/motel buildings comply with the applicable requirements found in **Section 130.4(a), 130.4(b), and 130.4(c)**. This includes the lighting control acceptance requirements, lighting control installation certificate requirements, and the certification of the acceptance testing technicians.

Requirements specific to automatic daylight controls are provided below:

LIGHTING CONTROL ACCEPTANCE REQUIREMENTS

Before an occupancy permit is granted, indoor and outdoor lighting controls serving the building, area, or site shall be certified as meeting the Acceptance Requirements for Code Compliance in accordance with **Section 130.4(a)**.

A Certificate of Acceptance shall be submitted to the enforcement agency under **Section 10-103(a) of Part 1**, that certifies all lighting acceptance testing necessary to meet requirements of Part 6 in the Building Energy Efficiency Standards are completed and that the technician has followed the functional test requirements outlined:

CONTINUED ON PAGE 79

ENERGY STANDARDS

ACCEPTANCE TESTING

Acceptance testing helps ensure building equipment and systems perform properly. It is important to note that acceptance testing is not a replacement for building commissioning requirements outlined in the previous section and **120.8** in the Standards. The acceptance testing process is as follows:

1. **Plan Review** (installing contractors, engineer of record)
Review plans and specifications to ensure they meet all Title 24 requirements. Typically done prior to signing a Certificate of Compliance.
2. **Construction Inspection** (installing contractor, engineer of record)
Check that the equipment installed is capable of complying with the requirements of the Standards. Construction inspection also assures that the equipment is installed correctly and is calibrated.
3. **Functional Testing** (Certified Acceptance Test Technician)
Acceptance tests are performed to ensure that all equipment performs as required by Title 24.
4. **Occupancy** (Enforcement Agency)
Once all required Certificates of Acceptance are submitted, the enforcement agency completes final inspection and releases a Certificate of Occupancy.

CONSTRUCTION INSPECTION

After completion of construction, an inspection is required to verify that automatic electric lighting controls are properly installed and fully functional in accordance with each applicable requirement in **Section 130.1(d)**.

FUNCTIONAL TESTING

All photocontrols serving more than 5,000 ft² of daylight area shall undergo functional testing. Photocontrols that are serving smaller spaces may be sampled as follows:

For buildings with up to five (5) photocontrols, all photocontrols shall be tested. For buildings with more than five (5) photocontrols, sampling may be done on spaces with similar sensors and cardinal orientations of glazing; sampling shall include a minimum of 1 photocontrol for each group of up to 5 additional photocontrols. If the first photocontrol in the sample group passes the functional test, the remaining building spaces in the sample group also pass. If the first photocontrol in the sample group fails the functional test, the rest of the photocontrols in the group shall be tested. If any tested photocontrol fails the functional test, it shall be repaired, replaced or adjusted until it passes the test.

For each photocontrol to be tested, do the following: test each group of lights controlled separately by the photocontrol according to the following protocol. In all interior spaces other than parking garages, a separate test shall be conducted for daylighting control of the primary sidelit zone separate from the secondary sidelit zone.

CONTINUED ON PAGE 80

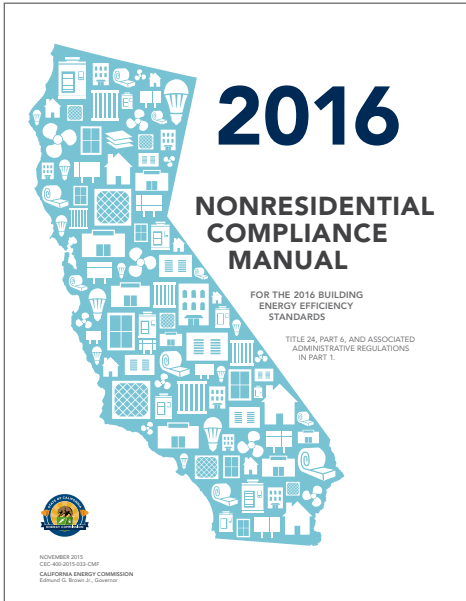

2016 Nonresidential Compliance Manual

For more information on acceptance requirements, refer to Chapter 13 of the 2016 Nonresidential Compliance Manual.

To view and download the 2016 Nonresidential Compliance manual, visit www.energy.ca.gov/title24/2016standards.

CONTINUOUS DIMMING CONTROL SYSTEMS

This requirement is for systems that have more than 10 levels of controlled light output in a given zone:

Step 1: Identify the minimum daylighting location in the controlled zone (Reference Location). This can be identified using either the illuminance method or the distance method.

- **Illuminance Method**

1. Turn OFF controlled lighting and measure daylight illuminance within zones illuminated by controlled luminaires.
2. Identify the reference location; this is the task location with lowest daylight illuminance in the zone illuminated by controlled luminaires. This location will be used for illuminance measurements in subsequent tests.

- **Distance Method**

1. Identify the task location within the zone illuminated by controlled luminaires that is farthest away from daylight sources. This is the Reference Location and will be used for illuminance measurements in subsequent tests.

Step 2: No daylight test. Simulate or provide conditions without daylight. Verify and document the following:

1. Automatic daylight control system provides appropriate control so that electric lighting system is providing full light output unless otherwise specified by design documents.
2. Document the reference illuminance, which is the electric lighting illuminance level at the reference location identified in Step 1.
3. Light output is stable with no discernible flicker.

Step 3: Full daylight test. Simulate or provide bright conditions. Verify and document the following:

1. Lighting power reduction is at least 65 percent under fully dimmed conditions and light output is stable with no discernible flicker.
2. Only luminaires in daylit zones are affected by daylight control. If the daylighting controls control lighting outside of the daylight zones, including those behind obstructions as described in **Section 130.1(d)1**, the control system is not compliant.
3. If a Power Adjustment Factor is claimed for Daylight Dimming plus OFF controls in accordance with **Section 140.6(a)2H**, compliant systems shall automatically turn OFF the luminaires that are receiving this credit. This portion of the full daylight test does not apply to lighting systems that are not claiming a Power Adjustment Factor for Daylight Dimming plus OFF controls.

CONTINUED ON PAGE 81

Step 4: Partial daylight test. Simulate or provide daylight conditions where illuminance (fc) from daylight only at the Reference Location is between 60 and 95 percent of Reference Illuminance (fc) documented in Step 2. Verify and document the following:

1. Measure that the combined illuminance of daylight and controlled electric lighting (fc) at the reference location is no less than the electric lighting illuminance (fc) at this location during the no daylight test documented in Step 3.2.
2. Measure that the combined illuminance of daylight and controlled electric lighting (fc) at the Reference Location is no greater than 150 percent of the reference illuminance (fc) documented in Step 3.2.
3. Light output is stable with no discernible flicker.

LIGHTING CONTROL INSTALLATION CERTIFICATE REQUIREMENTS

To be recognized for compliance with Part 6, an Installation Certificate shall be submitted in accordance with **Section 10-103(a)** for any lighting control system, Energy Management Control System, track lighting integral current limiter, track lighting supplementary overcurrent protection panel, interlocked lighting system, lighting Power Adjustment Factor, or additional wattage available for a videoconference studio, in accordance with the following requirements, as applicable:

1. Certification that when a lighting control system is installed to comply with lighting control requirements in Part 6 it complies with the applicable requirements of **Section 110.9**; and complies with **Reference Nonresidential Appendix NA7.7.1**.
2. Certification that when an Energy Management Control System is installed to function as a lighting control required by Part 6 it functionally meets all applicable requirements for each application for which it is installed, in accordance with **Sections 110.9, 130.0 through 130.5, 140.6 through 150.0, and 150.2**; and complies with **Reference Nonresidential Appendix NA7.7.2**.
3. Certification that line-voltage track lighting integral current limiters comply with the applicable requirements of **Section 110.9** and installed wattage has been determined in accordance with **Section 130.0(c)**; and comply with **Reference Nonresidential Appendix NA7.7.3**.

CONTINUED ON PAGE 82

The image shows a screenshot of the 'INDOOR LIGHTING CERTIFICATE OF INSTALLATION' form (NRCI-LTI-01-E) from the State of California Department of Industrial Relations. The form is titled 'INDOOR LIGHTING CERTIFICATE OF INSTALLATION' and includes a 'Page 1 of 2' indicator. It contains several sections: 'GENERAL INFORMATION' with fields for 'BUILDING TYPE' (Nonresidential, High-Rise Residential, Mixed-Use/Commercial) and 'PHASE OF CONSTRUCTION' (New Construction, Addition, Alteration, Groundwater); 'SCOPE OF RESPONSIBILITY' with a date field; and a table for listing applicable construction documents with columns for 'Document Title or Description', 'Applicable Sheets or Pages, Tables, Schedules, etc.', and 'Date Approved by Enforcement Agency'. There are 'Add Row' and 'Remove Last' buttons at the bottom of the table.

Certificates of Installation

These forms, signed by licensed professionals, certify that the lighting installed for the project corresponds with the lighting proposed on the Certificates of Compliance. NRCI-LTI-01-E is required for all indoor lighting.

To view and download compliance forms, visit www.energy.ca.gov/title24/2016standards.

4. Certification that line-voltage track lighting supplementary overcurrent protection panels comply with the applicable requirements of **Section 110.9** and installed wattage has been determined in accordance with **Section 130.0(c)**; and comply with **Reference Nonresidential Appendix NA7.7.4**.
5. Certification that interlocked lighting systems used to serve an approved area comply with **Section 140.6(a) 1**; and comply with **Reference Nonresidential Appendix NA7.7.5**.
6. Certification that lighting controls installed to earn a lighting Power Adjustment Factor (PAF) comply with **Section 140.6(a) 2**; and comply with **Reference Nonresidential Appendix NA7.7.6**.
7. Certification that additional lighting wattage installed for a videoconference studio complies with **Section 140.6(c) 2 G vii**; and complies with **Reference Nonresidential Appendix NA7.7.7**.

ACCEPTANCE TEST TECHNICIAN CERTIFICATION

When certification is required by Title 24, Part 1, **Section 10-103.2**, the acceptance testing specified by **Section 130.4** shall be performed by a Certified Lighting Controls Acceptance Test Technician (CLCATT).

If the CLCATT is operating as an employee, the CLCATT shall be employed by a Certified Lighting Controls Acceptance Test Employer. The CLCATT shall disclose on the Certificate of Acceptance a valid CLCATT certification identification number issued by an approved Acceptance Test Technician Certification Provider. The CLCATT shall complete all Certificate of Acceptance documentation in accordance with the applicable requirements in **Section 10-103(a) 4**.

CALCTP-AT Technician Training

CALCTP (calctp.org) is one of two training and certification programs recognized and approved by the Energy Commission to carry out lighting controls acceptance testing as required by the Energy Standards.

In order to be certified as a CALCTP Acceptance Test Technician, a person must:

- Be employed by a CALCTP-certified employer:
calctp.org/acceptance-technicians/contractors
- Have at least three years of experience with lighting controls
- Register on the CALCTP website calctp.org/acceptance-technicians
- Take the training course offered at one of the CALCTP training centers



ISTOCK.COM/LISAFEX





IN CLOSING

As solar energy has been a main factor in human evolution, daylight offers significant biological benefits in terms of circadian health and also excellent color vision. Introduction of daylighting in interior spaces offers additional psychological benefits in terms of providing connection to outdoors. The main challenge in realizing these benefits is the very high intensity and continuous change of direction of the direct solar radiation which can produce significant luminous and thermal discomfort without proper shading. Introducing daylight in buildings through envelope apertures also affects energy requirements for lighting and HVAC systems.

ISTOCK.COM/PIIUS99
KYOTO STATION, KYOTO, JAPAN



DAYLIGHTING & ENERGY EFFICIENCY

Daylighting can certainly reduce electric lighting requirements for ambient and task lighting in work spaces through use of technologies that adjust electric lighting output based on available daylight. The effects of daylight on HVAC loads is more complicated, as it affects both heating and cooling loads, either directly, i.e., through fenestration convective and conductive heat gain/loss and also through solar heat gain, which may be beneficial during heating periods, but certainly not during cooling periods. Moreover, daylight apertures can also be used for natural ventilation and cooling, further affecting HVAC loads.

The net annual impact of daylight on energy is the results of gains and losses that vary through the year and also by building location, which dictates climatic conditions and sun paths, and orientation of daylight apertures, which, along with external obstructions, greatly affect incident solar radiation. As cooling is the most important electricity load in commercial buildings in California, avoiding solar heat gain is critical to contributing to building energy efficiency, but can also compromise view and reduce electric lighting savings because of reduced indoor daylight levels. The latter is also true when shading systems are used to provide privacy or reduction of direct solar penetration for managing glare.

If energy were not an issue and view were the only benefit of daylight with glare from direct sun the only penalty, daylighting design would be very easy and simple, as low transmittance glazing provides view and resolves the glare issue. Realizing the energy benefits of daylighting, however, requires significant balancing of all performance aspects, which affected by multiple decisions by different disciplines, from site selection and architectural design to fenestration, interior and lighting design. Realization of the benefits is also affected by decisions made during building construction, commissioning and operation.



PHOTO: CORELITE

CALIFORNIA GREEN BUILDING STANDARDS

The California Building Energy Efficiency Standards (Energy Standards) aim at specifying minimum performance requirements, i.e., a building that just meets Title 24 requirements is, by definition, the worst energy-performing building allowed by law in California. However, effective daylight designs can offer much higher performance, not only in terms of energy efficiency, but also in terms of important non-energy performance aspects, such as comfort and health.

The California Building Standards Commission developed the California Green Building Standards Code, California Code of Regulations (CALGreen) in 2007 to address the California Global Warming Solutions Act of 2006 (AB 32) with the goal of reducing green-house gases (GHG) to 1990 levels by the year 2020. CALGreen contains both mandatory and voluntary green building measures.

CALGreen's purpose is to 'improve public health, safety and general welfare by enhancing the design and construction of buildings through the use of building concepts having a reduced negative impact or positive environmental impact and encouraging sustainable construction practices in the following categories:

- Planning and design,
- Energy Efficiency,
- Water efficiency and conservation,
- Material conservation and resource efficiency, and
- Environmental quality.'

CALGreen is one step toward more efficient and responsible building design. It is estimated by the California Air Resources Board that the mandatory elements of CALGreen will reduce GHG by three million metric tons by the year 2020.

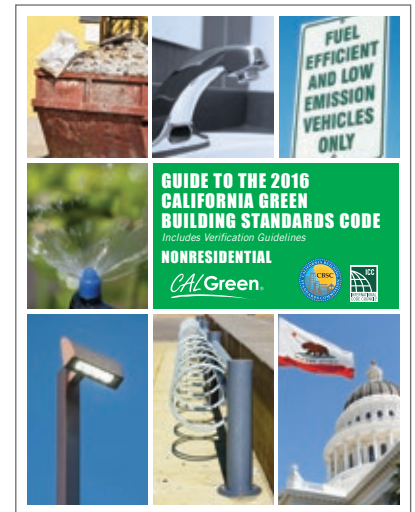

California Green Building Standards Code of Regulations (CALGreen)

Detailed information on how to effectively comply with mandatory measures and implement voluntary measures can be found here: www.bsc.ca.gov/Home/CALGreen.aspx.

DAYLIGHT MANAGEMENT



Benefits of Daylight Management

Managing daylight penetration based on outdoor and indoor environmental conditions can greatly increase daylight harvesting benefits, not only energy benefits, but also psychological, physiological and biological benefits.

Optimizing daylight performance is a challenging design task, as there are many performance aspects to be considered, which depend on building/space type and are affected by a wide range of contextual parameters, such as building/space site and orientation. Such multi-criterion optimizations require prioritization of performance aspects, e.g., keeping human comfort and health as top priorities, followed by energy efficiency.

Optimization of daylighting performance requires not only managing the electric lighting output based on available daylight, but also managing daylight transmittance through daylight apertures. Daylight management requires implementation of dynamic fenestration systems that automatically change status based on indoor and outdoor conditions, such as occupancy, daylight levels, and the status of electric lighting and HVAC systems.

Automated daylight management at the aperture level is required in many applications to realize the minimal energy savings resulting from electric lighting controls. Daylight management is required in most applications to control glare from direct solar penetration. It is usually achieved through use of shading systems and/or dynamic glazings. Manual operation of such systems can result in dramatic reduction of electric lighting savings, as occupants usually respond to needs, i.e., closing blinds to block direct solar penetration or privacy, but do not respond to opportunities, i.e., opening the blinds when the sun has passed or privacy is no longer needed. Moreover, automated daylight management can greatly reduce energy loads during vacancy periods, when occupants are not present to make adjustments. Such benefits include reduction in HVAC loads through control of direct solar penetration and natural ventilation and cooling through venting fenestration systems.

Electric lighting and HVAC controls can be autonomous, i.e., can operate effectively based on photo-sensor and temperature/humidity sensors, respectively. Fenestration controls, however, also require information about the status of the electric lighting and HVAC systems to be effective in reducing energy and peak demand. The rapidly decreasing costs of sensors and communications is increasing development and marketing of integrated controls that support communication between fenestration controls and lighting and HVAC systems. Communication with HVAC systems is most important, as daylight management can result in significantly different operation during heating and cooling periods and effectively realize natural ventilation and cooling.

The continuously decreasing cost of sensors and communications is resulting in an increase of integrated controls for daylight management, electric lighting and HVAC. Eventually they will become standard practice, maximizing both comfort and energy performance.



PHOTO: LUTRON

For more information and resources about Lighting Best Practices, visit the CLTC website at cltc.ucdavis.edu.

CALIFORNIA LIGHTING TECHNOLOGY CENTER
UNIVERSITY OF CALIFORNIA, DAVIS
633 Pena Drive
Davis, CA 95618
Phone: (530) 747-3838
Fax: (530) 747-3812
Email: cltc@ucdavis.edu

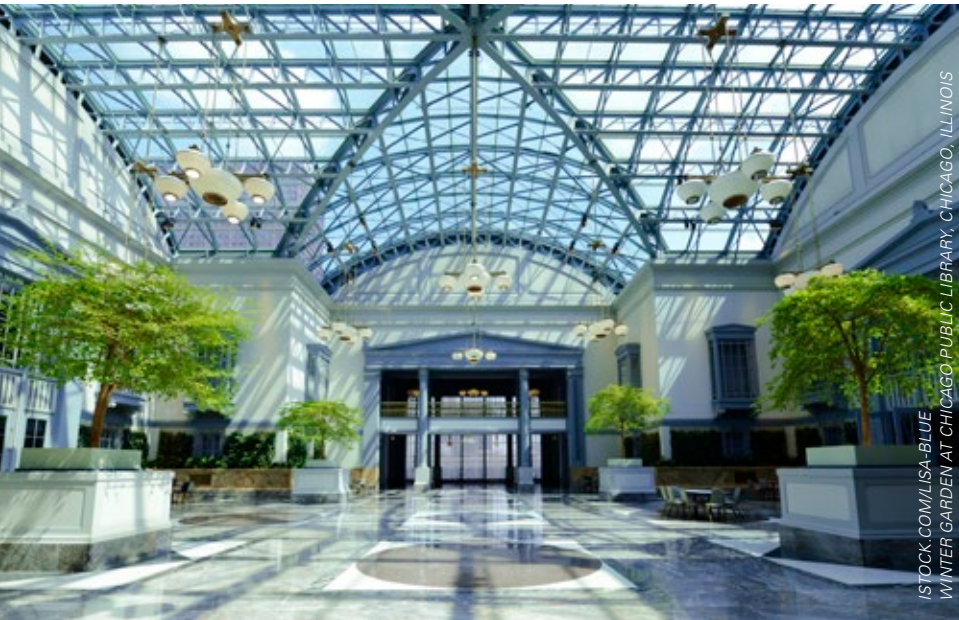

ISTOCK.COM/LISA-BLUE
WINTER GARDEN AT CHICAGO PUBLIC LIBRARY, CHICAGO, ILLINOIS



ISTOCK.COM/NEOMEZER
FOREST SCIENCES CENTRE, UNIVERSITY OF BRITISH COLUMBIA, VANCOUVER, CANADA



ISTOCK.COM/STURTI



ISTOCK.COM/RILUEDA