



Limitorque Automax CEA Series

Brushless DC Rotary Control Electric Actuator



Experience In Motion

Automax CEA Series

The new CEA series resets expectations for compact, single-phase electric actuators by bringing together an unprecedented range of user benefits in one high performance unit. Its use of intelligent technologies, suitability for numerous valve applications and extended service life provide a genuine breakthrough in capability for this type of actuator.

Now, industrial OEMs and end users specifying single phase electric actuators can benefit from enhanced cycle performance and advanced diagnostic capabilities.

Intelligent technology - customer inspired, user-friendly, Human Machine Interface (HMI) features auto calibration to provide optimized commissioning for valve automation. Available for the first time in single phase actuators, standard diagnostics include actuator temperature and valve torque monitoring with early warning detection of operating threshold and alarm output.

Valve application - the CEA not only meets typical rotary duty requirements (i.e. 90 and 180 degree operation), it is also capable of multi-turn duty, up to 20 turns, making it a cost effective and easily adaptable solution for rising stem valves.

Service life – the CEA uses precision-designed, worm gear drive trains and brushless DC (BLDC) motors to minimize unscheduled downtime. During qualification testing, the actuator demonstrated an unprecedented operating reliability of up to 250,000 on/off cycles. When configured for modulating service the CEA provides 1800 starts per hour with 0.1% position accuracy.

The CEA will be available in five sizes providing a continuous torque up to 565 Nm (5,000 in-lbs) and five design variants. See pages 4 and 5 for more details.

Fundamental to the development of the actuator was the need to meet global standards of approvals. The CEA is fully qualified to NEMA Type 4, 4X and 6, IP66/68 Class 1, Div 1 and 2, Gps B,C,D (CSA,FM) and ATEX II 2G Ex d IIB +H2 T4: IECEx II 2G Ex d IIB +H2 T4.

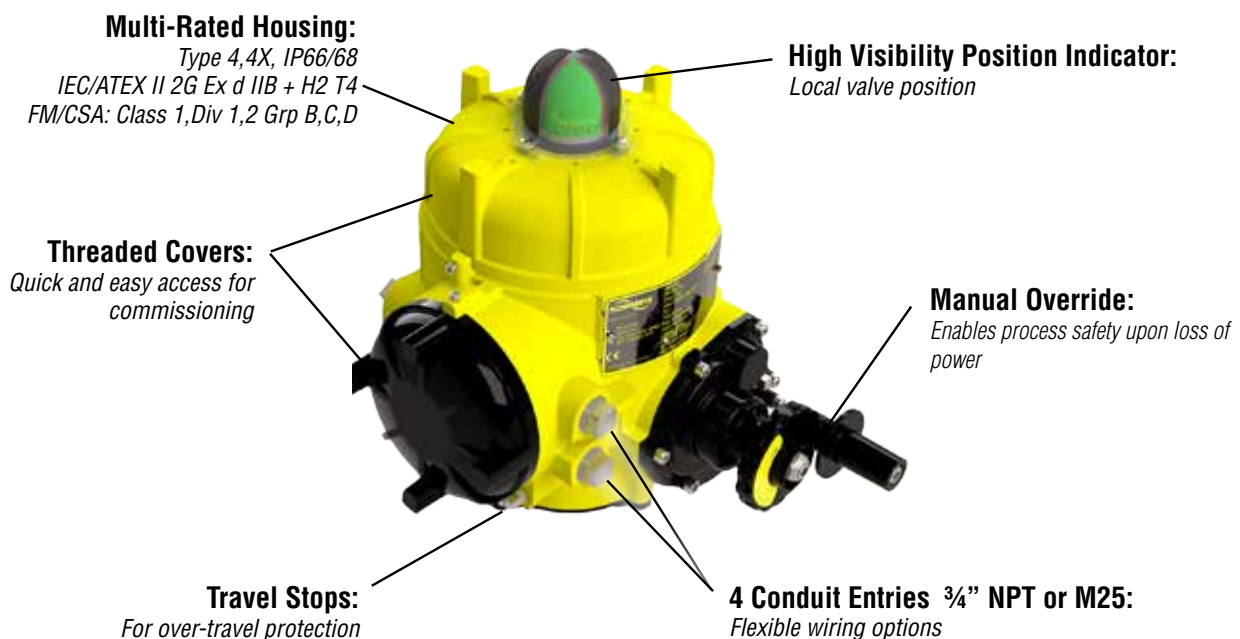

CEA Anatomy



User-friendly HMI with 2-line graphic display simplifies configuration and features auto calibration for quick and accurate commissioning for valve automation

Precision cut bronze worm gear set delivers maximum strength and durability with self-locking design to eliminate “back drive”

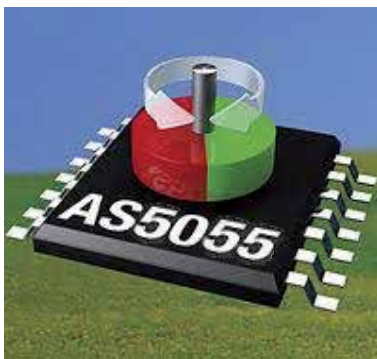
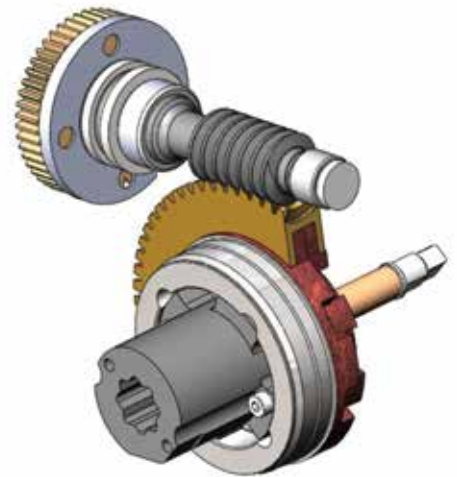

BLDC motor with 12-bit magnetic rotary position sensor provides high-cycle performance - the highest accuracy and reliability in electric motor design and control

Double-sealed terminal compartment's sealing protects motor and controls from unplanned moisture ingress via conduit runs





CEA Versions

The CEA is available in five versions to deliver the performance and technology required while tailored to meet the customer needs:

C-Pro: Professional Series

- Multi-rated housing
- On/off control
- Auto calibration
- Selectable torque, speed and rotation
- 2 or 3 position selectable control
- 4 selectable I/O for position and/or alarm output
- Multi-rated voltage

C-Net: Network Communications

- Pro Series plus optional Network Communications

- DeviceNet 
- ASi 
- HART wired 
- Modbus RTU 
- ProfiBus PA 
- Foundation Fieldbus H1 modulating 

C-Mod: Modulating Control

- Pro Series plus modulating control
- Analog setpoint control
- 0.1% accuracy
- Modbus RTU communication
- 21 programmable features



C-SLC: Single-Loop Control

- Pro Series plus Single-Loop Control
- Integrated PID process control
- Flow, pressure, temperature, level
- pH control applications
- Analog and RTD process inputs
- Auto tune function
- Local and remote setpoint function
- Modbus RTU communication

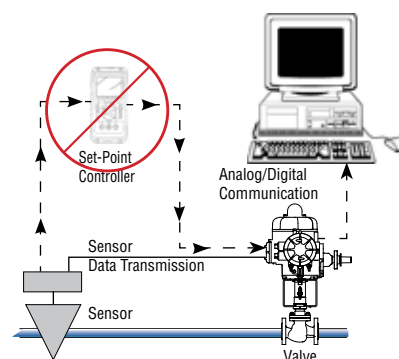

C-MT: Multi-Turn rotary control

- Pro Series plus multi-turn control
- 1-20 turns
- 1% position accuracy
- Position and/or torque seating
- Modbus RTU communication
- 21 programmable functions including:
 - Low power 24vdc control
 - Slow shaft detection
 - High current trip torque setting
 - Stall torque setting
 - Multi-rated voltage

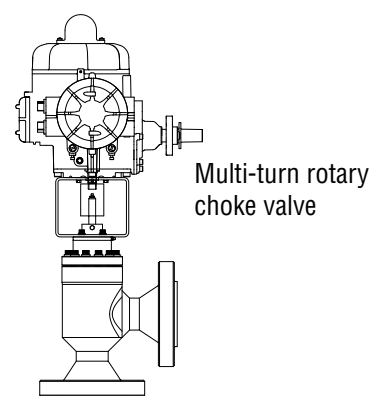

Performance Specifications

Version	Actuator Platform (PF)	Model	Output Torque (Continuous Start/Run Torque)	Stall Torque (1.25X)	Cycle Time (90°) 24VDC 120/240VAC	Output Speed 24VDC 120/240VAC	Full Load Amps		
							Units	Nm (in-lbs)	Nm (in-lbs)
Standard On/Off Modulating	PF1	M15	17 (150)	21 (187)	5	3	0.8A	0.15A	0.08A
		M60	68 (600)	85 (750)	5	3	2.1A	1.0A	0.49A
		M150	169 (1500)	211 (1875)	10	1.5	4.2A	1.4A	0.75A
	PF2	M250	282 (2500)	422 (3125)	16	0.9	6.5A	1.6A	.85A
		M500	565 (5000)	706 (6250)	33	0.5	6.5A	1.6A	.85A

Materials of Construction

Component	Material
Housing and Cover	Die cast aluminum
Aluminum surface treatment	Non-chrome conversion coating
Worm Gear set	Ductile iron (M15, M60); Ductile iron/bronze (M150, M250, M500)
Output Drive	Ductile iron
Baseplate	ISO 5211, F05/07, FA05/07
Paint	Polyester powder coat Salt spray: ASTM B117, 1050 hrs.

Technical Data

Voltage Rating	120/240 VAC/VDC; 12*/24 VDC; single (and optional 3-phase)
Temperature	-40C to +70C, low temp. option -48C
Environmental	Type 4, 4X,6, IP66/68 (3m for 48hrs) Class 1, Div 1,2, Gps B,C,D (CSA,FM) ATEX II 2G Ex d IIB +H2 T4: IECEx II 2G Ex d IIB +H2 T4
Vibration Testing	IEC60068-2-6 Appendix B
CE Declaration	Low voltage, EMI/EMC approval
Weight	M15/60: 24lbs (10.9kgs). M150: 25.5lbs (11.6kgs)

* For 12VDC, consult factory

Model Code

Model Code Example

X	C	PRO	60	W	90	1	0	0	0
---	---	-----	----	---	----	---	---	---	---

Brand	Series	Controls	Size	Certification	Rotation	Voltage	Output Options	Network Options	Options
A - ACCORD X - Automax	CEA	PRO - Professional MOD - Modulating NET - Networks SLC - Single Loop Control MT - Multi-Turn	15 60 150 250 500	W - Type 4, 4X, IP68 Z - FM/IEC/ATEX Explosion proof	90 - 90° 18 - 180° 36 - 360° MT - Multi-Turn (1 - 20 turns) MT1 - 1 turn MT7 - 7 turns MT10 - 10 turns MT12 - 12 turns MT17 - 17 turns MT20 - 20 turns	1 - 120/240VAC 2 - 12/24 VDC 3 - 120/240VAC & 12/24VDC	0 - None 4 - Analog 4-20mA	0 - None A - ASi D - DeviceNet F - Foundation Fieldbus H - Hart P - Profibus V - Valvesight (future)	0 - None B - Bluetooth D3 - Center Off H - Heater and Thermostat L - Local Control Station 9 - Cross-Line Mount Sxxx - Special Code

Dimensions inch (mm)

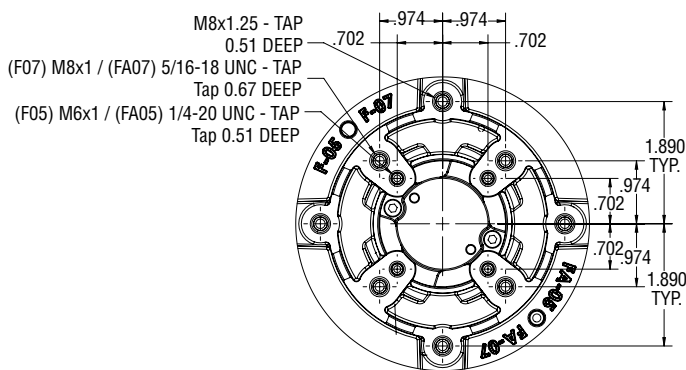
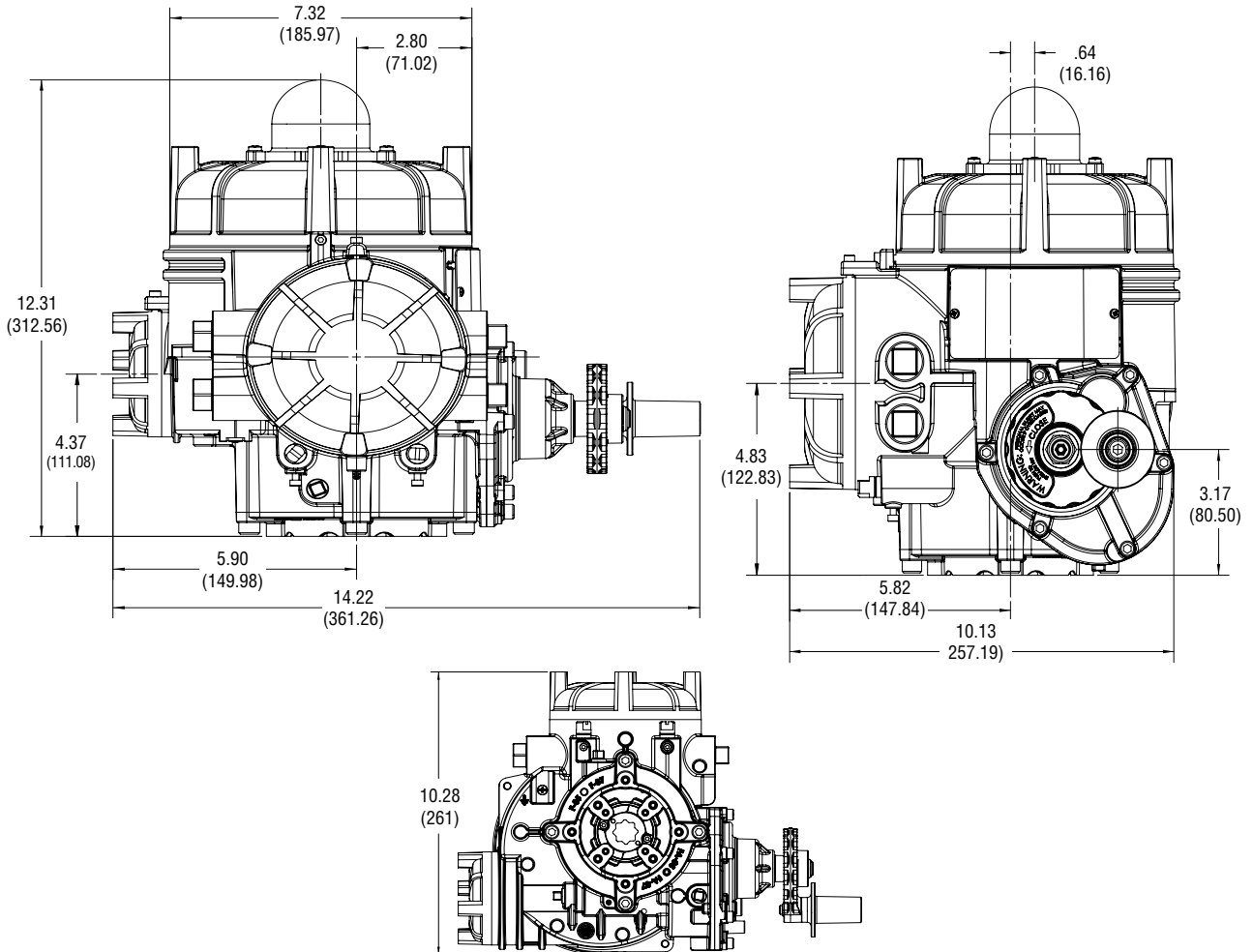

Mounting Blank Torque Nut
(F05/FA05 & F07/FA07)

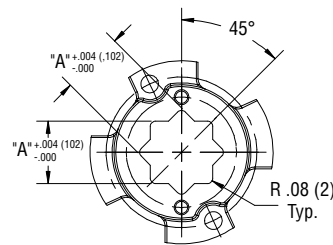

Double Square Torque Nut

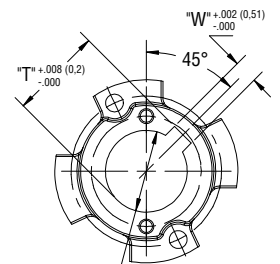

Bore Torque Nut

Double Square Torque Nut			Bore Torque Nut				
Description	"A" (Square)	Depth	Description	"Bore"	"T"	"W"	Depth
0.669 (17)	0.669 (17)	0.787 (20)	0.875-1/4x1/4	0.879 (22,3)	0.991 (25,1)	0.250 (6,35)	1.63 (41,4)
0.551 (14)	0.551 (14)	0.630 (16)	0.875-1/4x3/16	0.879 (22,3)	0.960 (24,3)	0.188 (4,77)	1.63 (41,4)



USA

1978 Foreman Drive
Cookeville, Tennessee 38501
USA
Phone: +1 931 432 4021
Facsimile: +1 931 432 3105

Europe, Middle East and Africa

Burrell Road
Haywards Heath
West Sussex RH16 1TL
UK
Phone: +44 (0)1444 314400
Facsimile: +44 (0)1444 314401

Asia Pacific

No. 35, Bayou Road
Suzhou Industrial Park
Suzhou 215021, Jiangsu Province
People's Republic of China
Phone: +86 512 6288 1688
Facsimile: +86 512 6288 8737

**To find your local Flowserve representative, visit
www.flowserve.com or call USA 1 800 225 6989 or
International +1 972 910 0774**

FCD AXENBR2080-00-A4 08/14 Printed in USA.

Flowserve Corporation has established industry leadership in the design and manufacture of its products. When properly selected, this Flowserve product is designed to perform its intended function safely during its useful life. However, the purchaser or user of Flowserve products should be aware that Flowserve products might be used in numerous applications under a wide variety of industrial service conditions. Although Flowserve can (and often does) provide general guidelines, it cannot provide specific data and warnings for all possible applications. The purchaser/user must therefore assume the ultimate responsibility for the proper sizing and selection, installation, operation and maintenance of Flowserve products. The purchaser/user should read and understand the Installation Operation Maintenance (IOM) instructions included with the product, and train its employees and contractors in the safe use of Flowserve products in connection with the specific application.

While the information and specifications contained in this literature are believed to be accurate, they are supplied for informative purposes only and should not be considered certified or as a guarantee of satisfactory results by reliance thereon. Nothing contained herein is to be construed as a warranty or guarantee, express or implied, regarding any matter with respect to this product. Because Flowserve is continually improving and upgrading its product design, the specifications, dimensions and information contained herein are subject to change without notice. Should any question arise concerning these provisions, the purchaser/user should contact Flowserve Corporation at any one of its worldwide operations or offices.

© 2014 Flowserve Corporation, Irving, Texas, USA. Flowserve is a registered trademark of Flowserve Corporation.