



**AALBORG UNIVERSITY**  
DENMARK

**Aalborg Universitet**

**Line Differential Protection Scheme Modelling for Underground 420 kV Cable Systems**  
*EMTDC/PSCAD Relays Modelling*

Sztykiel, Michal; Bak, Claus Leth; Wiechowski, Wojciech ; Dollerup, Sebastian

*Published in:*

Proceedings of MEPS'10 Symposium - Modern Electric Power Systems

*Publication date:*

2010

*Document Version*

Accepted author manuscript, peer reviewed version

[Link to publication from Aalborg University](#)

*Citation for published version (APA):*

Sztykiel, M., Bak, C. L., Wiechowski, W., & Dollerup, S. (2010). Line Differential Protection Scheme Modelling for Underground 420 kV Cable Systems: EMTDC/PSCAD Relays Modelling. In *Proceedings of MEPS'10 Symposium - Modern Electric Power Systems* Wroclaw University of Technology.

**General rights**

Copyright and moral rights for the publications made accessible in the public portal are retained by the authors and/or other copyright owners and it is a condition of accessing publications that users recognise and abide by the legal requirements associated with these rights.

- ? Users may download and print one copy of any publication from the public portal for the purpose of private study or research.
- ? You may not further distribute the material or use it for any profit-making activity or commercial gain
- ? You may freely distribute the URL identifying the publication in the public portal ?

**Take down policy**

If you believe that this document breaches copyright please contact us at [vbn@aub.aau.dk](mailto:vbn@aub.aau.dk) providing details, and we will remove access to the work immediately and investigate your claim.

# Line Differential Protection Scheme Modelling for Underground 420 kV Cable Systems

## EMTDC/PSCAD Relays Modelling

Michał Szykiel, Claus Leth Bak  
Department of Energy Technology  
Aalborg University  
Aalborg, Denmark  
clb@iet.aau.dk

Wojciech Wiechowski, Sebastian Dollerup  
Protection & Control Systems  
Energinet.dk  
Fredericia, Denmark  
sdo@energinet.dk

**Abstract**— Based on the analysis of a specific relay model and an HVAC (High Voltage Alternating Current) cable system, a new approach to EMTDC/PSCAD modelling of protective relays is presented. Such approach allows to create complex and accurate relay models derived from the original algorithms. Relay models can be applied with various systems, allowing to obtain the most optimal configuration of the protective relaying. The present paper describes modelling methodology on the basis of Siemens SIPROTEC 4 7SD522/610. Relay model was verified experimentally with its real equivalent by both EMTP-simulated and real world generated current signals connected to the relay.

**Keywords**— line differential protection; XLPE HVAC cable; EMTDC/PSCAD relay model; SIPROTEC 4 7SD522; 7SD610

### I. INTRODUCTION

Relay computer modelling is an important issue for establishing proper protection scheme for the specified system. Nowadays, it is difficult to obtain accurate relay computer model, since relay manufacturers offer their products with a variety of algorithms and features that may significantly change operation of relays under specific conditions and states.

For this purpose, essential study over new approach for creating relay models in EMTDC/PSCAD is given. The methodology relies on obtained relay's technical specification (given by relays manufacturer), so that unique features and algorithms - characteristic for each relay type, can be developed. As a result, this would give complex relay model narrowed and useful only for specified type of relay. In compensation, relay computer model would be very accurate (mainly in terms of sensitivity and operating speed) with easy and user-friendly configuration panel, which is programmed with the same parameter values as in real devices.

Established relay models would easily allow to perform simulations of chosen study cases and examine possibilities of unwanted tripping that might occur (e.g. due to transient power electronics switching, overvoltages, external faults, energization states, etc.).

This paper presents such analysis for Siemens line differential relays SIPROTEC 4 SD522/610, as these relays are

planned to protect HVAC underground transmission cable system built in Denmark in years 2012-2014.

Large capacitance of underground cables in comparison to overhead lines brings original issues for the differential protection scheme to consider, as both steady and transient states have to be deeply analyzed. For steady state, charging current is the factor that mostly affects relays function. For transient states, relays may be affected by inrush currents that occur due to shunt reactors switching operations (necessary for reactive power compensation).

In order to properly reflect cable system's influence over relay's current signals in mentioned states, cable system is modelled with the usage of EMTDC/PSCAD software, as it provides satisfactory accuracy for both steady and transient analysis.

When both cable system and protection scheme models are completed, relay model's accuracy can be finally verified through experimental testing. Having identical parameter setting both for relay model and real device, sensitivity and operating speed are compared thus showing high accuracy of the relay model.

Results from experimental analysis prove that presented approach for relay modelling can be successfully adapted for specific relays with original algorithms and features.

### II. PROTECTED CABLE SYSTEM - BACKGROUND

#### A. Cable System - Description

The single phase diagram of total cable system is shown on Fig. 1.

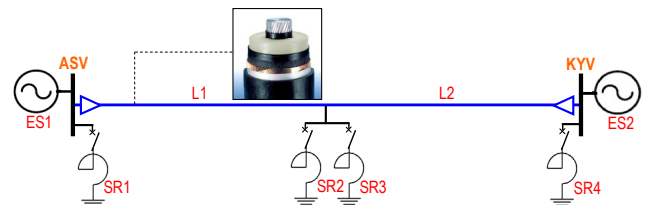

Figure 1. Schematic Representation of the Underground 420 kV Cable System.

The system consists of the following components:

1) *XLPE HVAC Underground Cable Sections (L1–L2)*: Selected cable is made of three aluminium single-core cables buried underground on the depth of 1,3 m and laid in a flat formation within 300 mm from each other. Total cable is divided into two sections of lengths accordingly 28 km and 29,5 km. Metallic screens of each cable section are cross-bonded approximately each 2 km, and earthed each 6 km. Detailed information about cable structure is presented on table I.

TABLE I. TECHNICAL DATA OF XLPE UNDERGROUND 420 kV CABLE

| Description                                   | Value |
|---|-------|
| Cross-section of conductor (mm <sup>2</sup> ) | 1600  |
| Diameter of conductor (mm)                    | 52    |
| Insulation thickness (mm)                     | 27,0  |
| Diameter over insulation (mm)                 | 110,0 |
| Cross-section of screen (mm <sup>2</sup> )    | 185   |
| Outer diameter of cable (mm)                  | 127,0 |
| Capacitance (μF/km)                           | 0,21  |
| Inductance (mH/km)                            | 0,50  |
| Charging current per phase (A/km)             | 14,9  |

2) *Shunt Reactor Banks (SR1–SR4)*: For reactive power compensation, four switchable shunt reactors are installed; each on ASV, KYV bus bars with reactive power of 100 MVARs and two between cable sections with reactive power of 140 MVARs.

3) *Supply Sources (ES1–ES2)*: Power system on both sides of the cable is modelled by ES1 and ES2 sources that are Thevenin equivalents consisting of voltage sources and its short-circuit impedances. Parameter values are listed on table II.

TABLE II. TECHNICAL DATA OF CABLE'S SUPPLY SOURCES

| Supply Source | Voltage (kV) | Short-circuit impedance (Ω) |
|---------------|--------------|-----------------------------|
| ES1           | 420          | 0.829 + j16.60              |
| ES2           | 420          | 0.839 + j16.78              |

### B. EMTDC/PSCAD Model of Cable System

In Fig. 2, described cable system is modelled in EMTDC/PSCAD software by frequency dependent (phase) model, giving highest accuracy among other available models [5]. Such modelled cable system may accurately reflect behaviour of the protection scheme under various transient states that are likely to appear. Further detailed information about establishing computer model of the cable is available in [5].

Shunt reactors are modelled with series resistance and inductance parameter values for each phase.

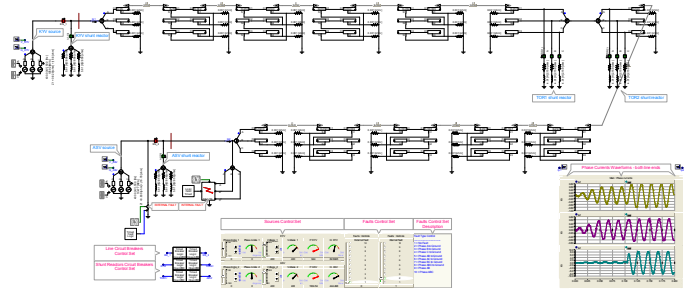

Figure 2. EMTDC/PSCAD Representation of the Underground 420 kV Cable System.

Table III shows validation results for three possible currents that can flow through protected cable. Parameters were chosen that mostly affect proper function of established differential protection. Detailed methodology for cable model validation along with series of calculations are given in [1-3].

TABLE III. VALIDATION RESULTS FOR EMTDC/PSCAD UNDERGROUND CABLE MODEL

| Description                                    | Theoretical Analysis | EMTDC/PSCAD Model | Relative error $e_r$ (%) |
|--|----------------------|-------------------|--------------------------|
| Maximum Charging Current (kA)                  | 0,878                | 0,805             | 8,3                      |
| External Fault at ASV substation (kA)          | 9,555                | 11,49             | 16                       |
| Internal Fault in the middle of the cable (kA) | 11,85                | 12,94             | 8,4                      |

Relative error is calculated from  $e_r = 100 \cdot |I_{TA} - I_{PSCAD}| / I_{TA}$ , where:  $I_{TA}$  – current parameter value obtained algebraically;  $I_{PSCAD}$  – current parameter value obtained numerically.

Relative error originates from cable geometry, since mutual couplings between internal conductive cable layers take place. This corresponds to core conductors and screens that are in close proximity to each other. Resulting inductive reactance for single phase is lower than calculated algebraically, thus giving higher current value which rises significantly when high currents flow through cable [2].

Validation results allow to conclude that certain error level occurs and has to be taken into account. Higher fault current values from EMTDC/PSCAD simulations allow to keep safety margin for the analysis based on simulation results.

### C. Differential Protection Scheme – Description

Total differential protection scheme for the analyzed cable system is presented in Fig. 3.

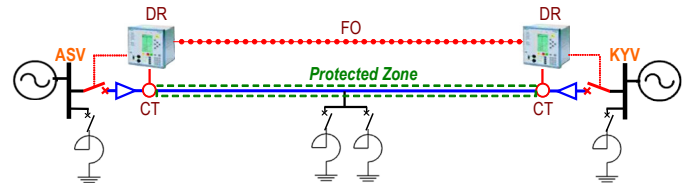

Figure 3. Schematic Representation of the Differential Protection Scheme over Underground 420 kV Cable System.

Proposed protection scheme consists of following components:

1) *Current Transformers (CT)*: Devices responsible for current signal transformation on the level applicable for measuring instruments installed in protection relays. Table IV shows current transformers specification used for computer modelling purpose.

TABLE IV. TECHNICAL DATA OF CURRENT TRANSFORMERS (CT)

| Parameter                   | Value       |
|-----------------------------|-------------|
| CT manufacturer's model     | ABB IMB 420 |
| CT class                    | 5P          |
| Transformation ratio (A/A)  | 1000/1      |
| Accuracy Limit Factor – ALF | 100         |
| Nominal Power (VA)          | 15          |

2) *Mono-mode Fibre Optic Cables (FO)*: Communication channels responsible for proper signal transmission between relays. Due to significant length of the protected cable (58,5 km), signal attenuation phenomenon must be considered along with time delay between sending and reaching signal from both sides of the protected cable. Reference [2] explains detailed solution methodology to stated issues. Channel time delay is calculated based on datasheet provided by fibre optic cable's and relay's manufacturers. Necessary data are gathered in table V.

TABLE V. TECHNICAL DATA OF FIBRE OPTIC CABLES (FO)

| Index    | Parameter                     | Value  |
|----------|-------------------------------|--------|
| $v_B$    | Bandwidth Data Speed (bits/s) | 512    |
| $l_{FO}$ | FO Length (km)                | 58,5   |
| $v_{FO}$ | FO Speed of Light (km/s)      | 200000 |
| $l_B$    | HDLC Frame Length (bits)      | 200    |

Channel time delay  $T_{delay}$  is 1,07 ms, calculated from

$$T_{delay} = T_s + T_t + T_r = \frac{l_B}{v_B} + \frac{l_{FO}}{v_{FO}} + \frac{l_B}{v_B}, \quad (1)$$

where

$T_s$  – time for sending signal by the local relay,

$T_t$  – time for transmitting signal through FO cable,

$T_r$  – time for receiving signal by the remote relay.

3) *Line Differential Relays (DR)*: Most complex components realizing signal measurement, signal comparison and finally - fault detection principles. Relays analyzed in this paper are Siemens SIPROTEC 4 7SD522. Detailed technical specification, instruction on establishing proper configuration parameter set are available in [1], [3] and [4].

#### D. EMTDC/PSCAD Model of Differential Protection Scheme

A general approach is introduced for protection scheme modelling in PSCAD software.

Based on previous components description, their unique characteristic functions are presented on Fig. 4. Each component is responsible for:

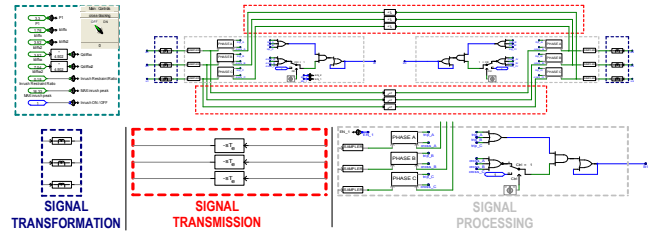

Figure 4. EMTDC/PSCAD Representation of the Differential Protection Scheme over Underground 420 kV Cable System.

- **Signal transformation**, modelled by Current Transformer Lucas model blocks with specified parameter settings. Reference [6] provides more information regarding CT Lucas model.
- **Signal transmission**, modelled by time delay blocks with specified and calculated time delay value from (1).
- **Signal processing**, modelled with complex block combination, reflecting operation algorithm and original features of real relays.

### III. EMTDC/PSCAD RELAY MODELLING

Relay EMTDC/PSCAD computer model is created in a shape of box with three phase modules included, so that all operations are phase segregated as in real relays (see Fig. 7). Input signals for modules are previously sampled with sampler blocks, so that 20 sampled values appear each full cycle period (fixed frequency) [3]. Output logic signal  $B1$  is responsible for controlling line circuit breaker in case of possible fault occurrence. Following features are included in each phase module:

1) *Sample Acquisition*: Operation necessary for further phasor and charge computations. Sample values  $i_n$  have to be stored during full cycle. This operation is available by implementing 20 Sample/Hold blocks – each controlled by logic pulse generator block, as presented on Fig. 5. Pulse generator blocks give command  $D$  for each sample/hold block. Generated pulses are shifted to each other by 18 degrees of total cycle period.

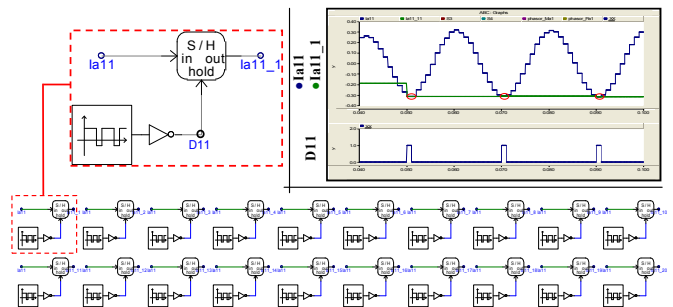

Figure 5. EMTDC/PSCAD Representation of Sample Acquisition Technique.

2) *Phasor Measurement*: current phasor values  $\underline{I}$  are obtained in the shape of complex numbers through Discrete Fourier Transform technique, based on

$$\underline{I} = I_S + j \cdot I_C, \quad (2)$$

where

$$I_S = \frac{2}{N} \cdot \left[ \sum_{n=1}^{N-1} \sin(\omega \cdot n \cdot \Delta t) \cdot i_n \right], \quad (3)$$

$$I_C = \frac{2}{N} \cdot \left[ \frac{i_0}{2} + \frac{i_N}{2} + \sum_{n=1}^{N-1} \cos(\omega \cdot n \cdot \Delta t) \cdot i_n \right]. \quad (4)$$

Herein are

$n = 1, 2, \dots, 20$  – sample number,

$i_n$  – current sample value corresponding to sample  $n$ ,

$\omega = 2 \cdot f \cdot \pi$  – cycle pulsation,

$\Delta t = (f \cdot N)^{-1}$  – sample time interval,

$f = 50$  Hz – frequency,

$N = 20$  – number of samples over one cycle.

Equations (3) and (4) are realized by correlating sample values with sine and cosine waveforms and summing them each full cycle period [1].

3) *Charge Measurement*: Charge values  $Q$  are obtained based on

$$Q = \int_{0+n}^{5+n} i \cdot dt \approx \sum_{i=n}^{n+5} i_i \cdot \Delta t_i. \quad (5)$$

Four charge values are calculated each full cycle period. By applying signal switch block, final charge signal is switched each quarter cycle. This corresponds to real relay feature, where charge comparison is performed four times more often than phasor comparison.

4) *Phasor Comparison*: based on relay's principles given in [1], values for operational phasor  $I_{OP}$  and restraint phasor  $I_{RES}$  are obtained and relay operating criterion is

$$I_{OP} > I_{RES}, \quad (6)$$

for

$$I_{RES} = I_{diff} > + \begin{cases} P2 \cdot |L_1| : |L_1| \leq P1 \\ P3 \cdot |L_1| : |L_1| > P1 \end{cases} + \begin{cases} P2 \cdot |L_2| : |L_2| \leq P1 \\ P3 \cdot |L_2| : |L_2| > P1 \end{cases}, \quad (7)$$

$$I_{OP} = |L_1 + L_2|. \quad (8)$$

Relay setting parameters  $P1, P2, P3$  and  $I_{diff} >$  are chosen based on procedure given in [3] and [4]. Parameters  $L_1$  and  $L_2$  are current phasor values correspondingly measured by local and remote relays. Operation of switching multiplying factors for restraint phasor (determined by current signal value – in fault state or load state) is made with the usage of comparator blocks, which output signal is multiplied by its corresponding actual phasor current signal value, as shown on Fig. 6.

Based on information obtained from the position of line circuit breaker installed on the same side as device, differential relay can detect “dead line” state when no current flows through the protected cable. Cable energization state – when circuit breaker is suddenly switched on – is detected by Edge Detector block by positive transition appearance of signal from line circuit breakers. This allows generating digital impulse, which is later extended to the specified time interval -  $Td$  setting, which can be changed based on relay settings by Monostable Multivibrator block.

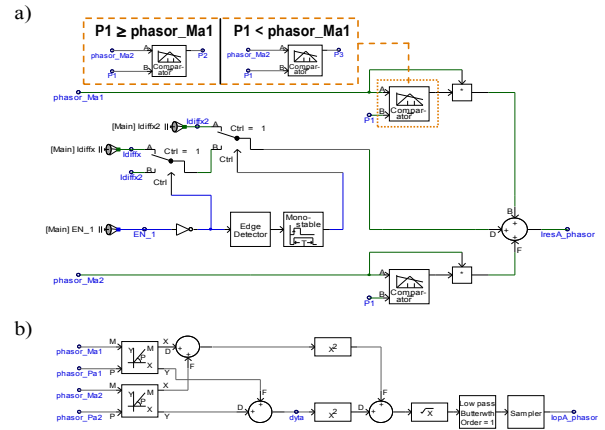

Figure 6. EMTDC/PSCAD Representation of Phasor Comparison technique: a) Restraint phasor  $I_{RES}$ , b) Operational phasor  $I_{OP}$ .

5) *Charge Comparison*: for this technique, the same algorithm is used as for phasor comparison.  $I_{diff} >$  parameter is replaced with minimum threshold value for charges:  $I_{diff} >$ . In addition, phasor signals are replaced with their corresponding operational  $Q_{OP}$  and restraint  $Q_{RES}$  charge values.

6) *Signal Filtering*: operational and restraint values are filtered using low-pass Butterworth filter block with established frequency threshold corresponding to each comparison technique.

7) *Inrush Restraint*: 2nd harmonic phasor currents  $L_{2nd}$  are measured by online frequency scanner blocks. If its values exceed established ratio  $k_{ratio}$  of 1st harmonic  $L_{1st}$ , relay prevents tripping operation. In EMTDC/PSCAD model this feature can be switched OFF as in real relays. Condition statement (9) has to be fulfilled in order to activate inrush restraint blocking feature. Upper limit for non-tripping operation is established with  $I_{max\_peak}$  parameter

$$(|L_{2nd}| > k_{ratio} \cdot |L_{1st}|) \wedge (|L_{1st}| < I_{max\_peak}). \quad (9)$$

Comparison principles are obtained with a combination of comparator blocks. Output signals from comparators can then

be combined with logic gates so that tripping signal depends on the resulting signal from the inrush restraint feature.

8) *Cross-blocking*: in order to prevent tripping signals from all three phases when inrush feature is active in only single phase, cross-blocking feature is introduced. Its PSCAD representation is shown on Fig. 7.

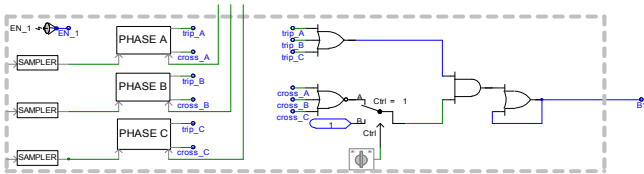

Figure 7. EMTDC/PSCAD Representation of Cross-Blocking Technique.

In EMTDC/PSCAD computer model, cross-blocking utilizes single phase tripping and inrush activation signals as the output signals of each phase module. Combining them all with logic gates gives final tripping signal decision  $BI$ . Hence, described feature has to be implemented outside phase modules. As in real relays, feature can be permanently switched OFF during normal operation.

**Original EMTDC/PSCAD files with fully established and configured models of relays and protected cable system are available at main author on request.**

#### IV. EMTDC/PSCAD SIMULATION CASES

##### A. Two-Phase External Fault at KYV substation

External fault simulation in phases A and B allows analysis on how relay computer model reacts when high currents flow through the protected cable. Fault is cleared after 55 ms by virtual bus protection installed in place where fault occurred. All shunt reactors are disconnected (highest charging current). Simulation graphs are presented on Fig. 8.

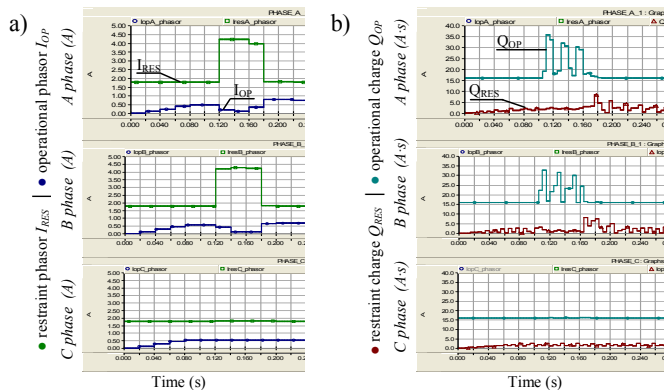

Figure 8. External Fault State at 10 ms: a) Phasor Comparison Technique, b) Charge Comparison Technique.

Due to high currents flowing through phases A and B which are higher than calculated  $PI$  value [4], transition takes place resulting in switching multiplying factors from  $P2$  to  $P3$

value. This means that transformed secondary current lies within fault area and security margin is increased in corresponding phases. On presented plots, restraint threshold is higher for the time when external fault current flows. After fault clearing, restraint values return to its normal threshold levels since transformed current lies once again within load area. An increase of operational values in phases with high current appears after fault clearing, giving large safety margin in order to prevent unwanted tripping. It is seen that during whole simulation operational values do not exceed restraint ones. As a result, relay properly does not detect any fault within protected cable and does not send tripping signal.

##### B. Single-Phase Internal Fault at KYV substation

Simulation test involves internal fault appearance in phase A within protected cable. As the worst case scenario, single A-phase fault is applied with high resistance  $R_{fault} = 20 \Omega$  and all shunt reactors are switched ON (lowest charging current). Computer model with established setting parameters should be able to properly detect and recognize fault state within phases. Figure 9 presents described simulation case results.

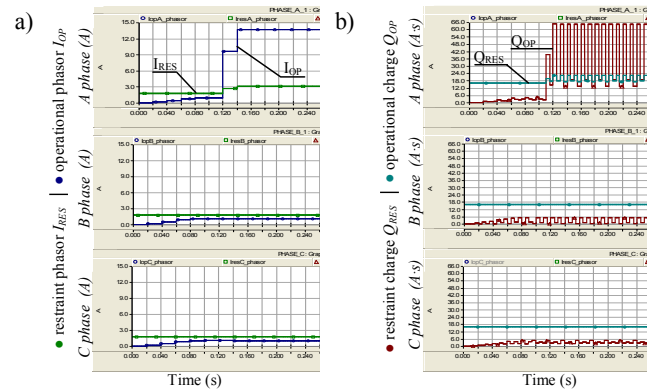

Figure 9. Internal Fault State at 10 ms: a) Phasor Comparison Technique, b) Charge Comparison Technique.

As expected, internal fault occurred in A phase and is detected by relay computer model both with phasor and charge comparison techniques. Operational values significantly exceed restraint ones after 20 ms from fault occurrence for phasor and 15ms for charge comparison principles. Earlier fault detection with charge technique results in sending tripping signal after 15ms in order to disconnect faulted cable.

#### V. RELAY TESTING

##### A. Description

Relay experimental testing is possible with the usage of modern equipment and software capable of converting current signals from EMTDC/PSCAD software into current waveforms injected into real differential relays. Simplified diagram of experimental test setup is presented on Fig. 10.

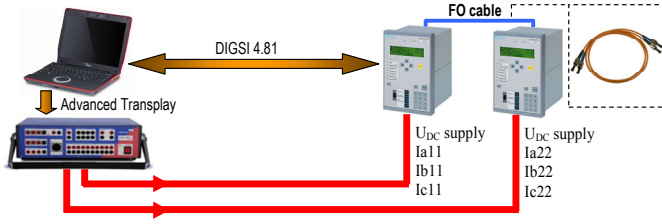

Figure 10. Experimental Test Setup.

Six current signals are sent:  $I_{a11}$ ,  $I_{b11}$ ,  $I_{c11}$ ,  $I_{a22}$ ,  $I_{b22}$ ,  $I_{c22}$  from which three enter to each relay accordingly to the side from which they were measured. Relays interconnected together with fibre optic cable, respond based on delivered signals with measured values and annunciation messages saved as logs. These logs can then be sent to PC and read in DIGSI software for further analysis and for comparison purposes.

### B. Results

All tests from experimental analysis and EMTDC/PSCAD simulations were performed with the same setting parameter values. Relay's operating speed and sensitivity have been examined.

1) *Operating Speed*: Operating speed analysis gives idea on how fast relay is able to detect fault states. By the analysis of restraint/operational plots in EMTDC/PSCAD computer software, time interval between exceeding threshold by operational charge value  $Q_{OP}$  and phasor value  $I_{OP}$  can be compared with the ones obtained from DIGSI logs. Analyzed study case results are presented on table VI.

TABLE VI. VALIDATION RESULTS OF OPERATING SPEED FOR EMTDC/PSCAD RELAY MODEL

| Case description                                    | Time interval (ms)   |                          |
|---|----------------------|--------------------------|
|   | Experimental Results | PSCAD Simulation Results |
| Single-phase to ground internal fault in the middle | 8                    | 14                       |
| Single-phase to ground internal fault at KYV busbar | 8                    | 14                       |
| Two-phase to ground internal fault at KYV busbar    | 14   14              | 15   15                  |
| Three-phase to ground internal fault KYV busbar     | 18   12   18         | 15   10   15             |

2) *Sensitivity*: Relay's sensitivity analysis is critical for proper internal fault states recognition. For this reason, internal faults with very high resistance values were analyzed. Differential threshold parameter  $I_{diff}$  for phasor comparison was adjusted in order to obtain its critical threshold values. Results are listed and compared in table VII. Phasor comparison is examined since it is more sensitive and necessary for proper fault detection. Critical values are these on which relay still detects fault and - if increased of a single setting step - makes no reaction for the same fault conditions.

TABLE VII. VALIDATION RESULTS OF SENSITIVITY FOR EMTDC/PSCAD RELAY MODEL

| Internal fault resistance ( $\Omega$ ) | Differential phasor $I_{diff}$ threshold for tripping |                          | Differential phasor $I_{diff}$ threshold for non-tripping |                          |
|--|---|--------------------------|---|--------------------------|
|  | Experimental Results                                  | PSCAD Simulation Results | Experimental Results                                      | PSCAD Simulation Results |
| 55                                     | 4,02  | 4,05                     | 4,03  | 4,06                     |
| 70                                     | 3,23  | 3,25                     | 3,24  | 3,26                     |
| 145                                    | 1,72  | 1,73                     | 1,73  | 1,74                     |
| 210                                    | 1,31  | 1,32                     | 1,32  | 1,33                     |

## VI. CONCLUSIONS

EMTDC/PSCAD relay computer model proves to be reliable and efficient from taken simulation cases with established parameter set. Apart from internal and external fault states, analyzed simulation cases included transmission cable's energization and shunt reactor's energization states, giving overall 10 different study cases [2]. All simulation results have been successfully compliant with the expected ones.

According to simulation results, relay model is able to accurately detect internal faults and differentiate them with mentioned other states that may be misleading. Very high fault resistances from which relay cannot detect faults marks efficiency of specific algorithms implemented and used for measurement and comparison purposes of the obtained signals.

## VII. ACKNOWLEDGMENT

The first author gratefully acknowledges research support from the Danish TSO - Energinet.dk, which delivered all necessary technical data of the analyzed system along with Siemens SIPROTEC 4 7SD522 relays.

## VIII. REFERENCES

- [1] G. Ziegler, *Numerical Differential Protection: Principles and Applications*, Nuremberg, Germany: Siemens AG, Jul. 2005.
- [2] M. Szykiel, "Protection philosophies for HVAC transmission network," M.S. thesis, IET, Aalborg Univ., Aalborg, Denmark, 2009.
- [3] *SIPROTEC 4 Differential Protection 7SD52 V4.1 Manual*, Siemens AG, Nuremberg, Germany, 2002.
- [4] T. Sezi *et al.*, "Field Experience Summary with a Line Differential Relay Using Complex Communication Infrastructure," Siemens Energy, Inc., Nuremberg, Germany, Sep. 2009.
- [5] *Applications of PSCAD/EMTDC Application Guide*, Manitoba HVDC Research Centre Inc., Winnipeg, Canada.
- [6] J. Rohan Lucas, "Representation of Magnetisation Curves over a wide region using a non-integer power series," *IJEEE*: Manchester Univ. Press, vol. 25, No 4, pp. 335-340, Oct. 1988.