

71-2045-250
8/08

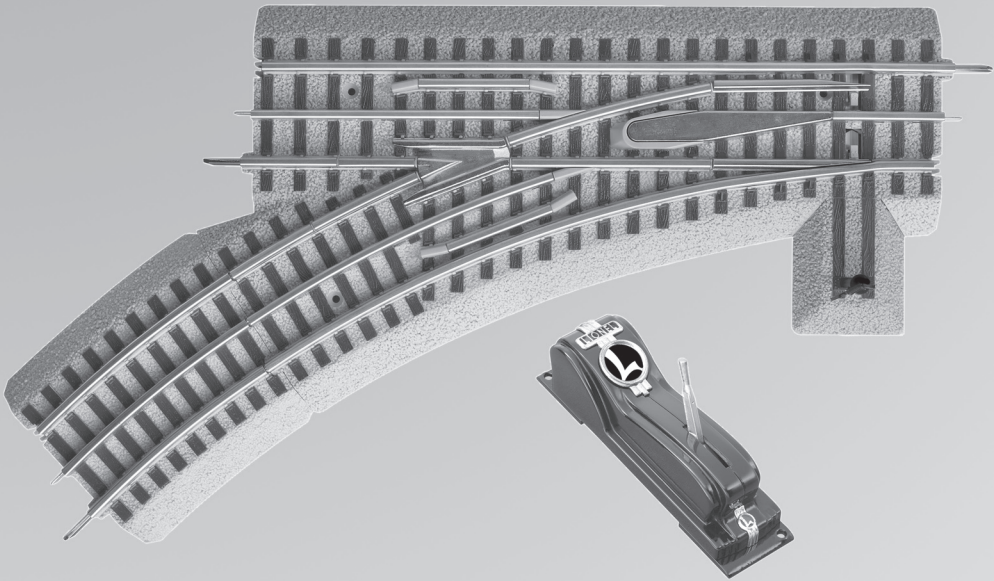

FastTrack®



***Lionel
036 Remote Switch
Owner's Manual***

Congratulations on your purchase of the Lionel FasTrack O36 Remote Switch! This switch features a non-derailing function, a lighted switch lamp, and a lighted controller. The switch connects easily to other FasTrack track sections. Use the switch to join two track loops, create a switching yard, or add a siding. The switch can replace a straight ten-inch track section or an O36 curve section.

Table of contents

Joining the FasTrack track sections	3
Operating the switch	4
Changing the switch stand location	5
Routing the controller cable	6
Mounting the controllers	7
Numbering your switch controllers	7
Powering the switch through a separate power supply	8
Connecting the controller	9
Operating the switch in the TrainMaster Command Control environment	9-10
Servicing the lamps	11
Limited Warranty/Lionel Service	12

The following Lionel marks may be used throughout this instruction manual and are protected under law. All rights reserved.

Lionel®, *TrainMaster®*, *Odyssey®*, *RailSounds®*, *CrewTalk™*, *TowerCom™*, *DynaChuff™*, *StationSounds™*, *Pullmor®*, *ElectroCoupler™*, *Magne-Traction®*, *CAB-1® Remote Controller*, *PowerMaster®*, *Lionel ZW®*, *ZW®*, *PowerHouse®*, *TMCC®*, *Lionelville™*, *Lockon®*, *Wireless Tether™*, *LionMaster®*, *FatBoy™*, *American Flyer®*, *TrainSounds™*, *PowerMax™*, *LEGACY™*, *PowerMax™ Plus*

The name FasTrack® is used with permission from Pitsco, Inc.

Joining the FasTrack track sections

FasTrack track sections join together easily. With interlocking roadbed sections and large rail tabs, the track fits together securely so you always get good electrical contact. Refer to Figure 1 to see how to join the track sections.

1. Line up your two sections of track.
2. Insert the rail tabs into the openings at the ends of the corresponding rails.
3. Press the sections together until the interlocking roadbed snaps into place.

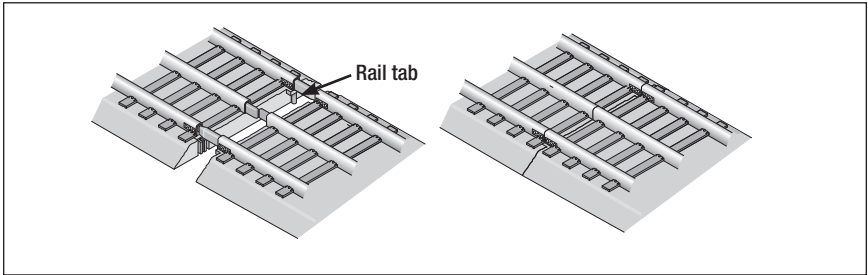

Figure 1. Joining the track sections

Operating the switch

You may operate the switch using the controller or the illuminated switch lamp on the roadbed. Refer to Figure 2.

To operate the switch using the controller, power up the track, then pull the lever to the opposite position. Gently press the lever past the end of its path. The lights inside the controller will change colors to designate the change in switch positions. The red lights designate the curved path. The green lights designate the straight path.

Note! Track power must be on to operate the switch using the controller.

To operate the switch using the switch lamp, simply rotate the switch lamp. The new position of the colored lenses on the lamp designate the change in switch positions.

Note! This switch is equipped with a non-derailing feature. The train's wheels automatically throw the blades to the proper position when the train travels toward the converging track. If you experience difficulties, simply use the controller or switch lamp to throw the switch into the correct position for the train to travel.

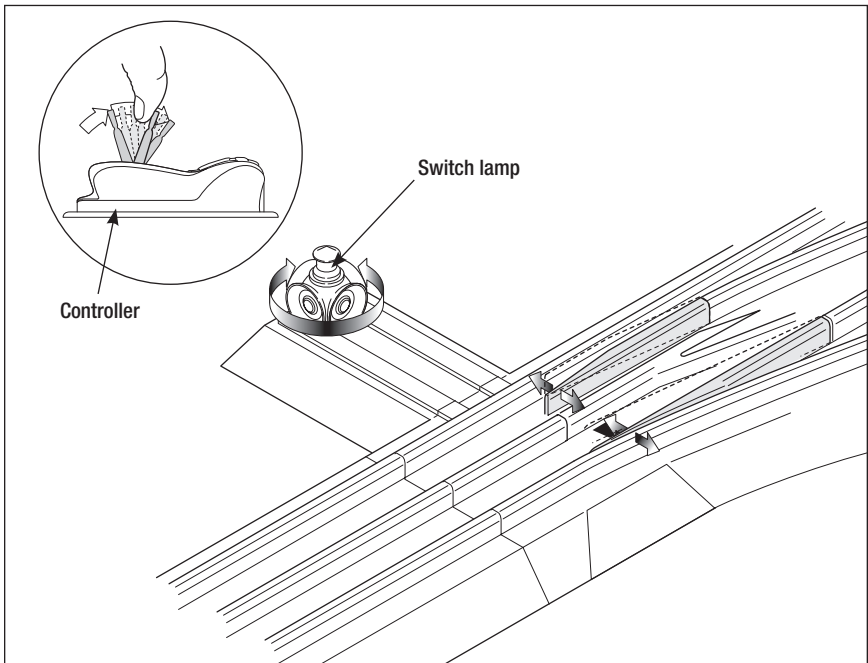

Figure 2. Switch operation

Changing the switch stand location

You may choose to position the switch stand either inside or outside the loop of track. Follow these steps and refer to Figure 3 to change the location of the switch stand.

1. Remove the two screws that secure the small roadbed section to the switch and lift away the roadbed section.
2. Place the “blades,” or moving rails, in the proper position to make removing the switch stand roadbed section easier.
 - If the switch stand is being removed from the curved side, the blades should be set to the through/straight position.
 - If the switch stand is being removed from the straight side, the blades should be set to the out/curve position.
3. Remove the two screws that secure the switch stand roadbed section to the switch. Please note that these screws are located towards the inside edge of the switch stand roadbed section. Lift away the switch stand roadbed section.
4. Install the switch stand roadbed section at its new location. The posts on the switch should be inserted into the holes on the switch stand roadbed section. The pin on the switch stand mechanism should be inserted into the slot on the switch control arm. Insert the two screws to secure the switch stand.
5. Install the small roadbed section, securing it in place with the two screws.

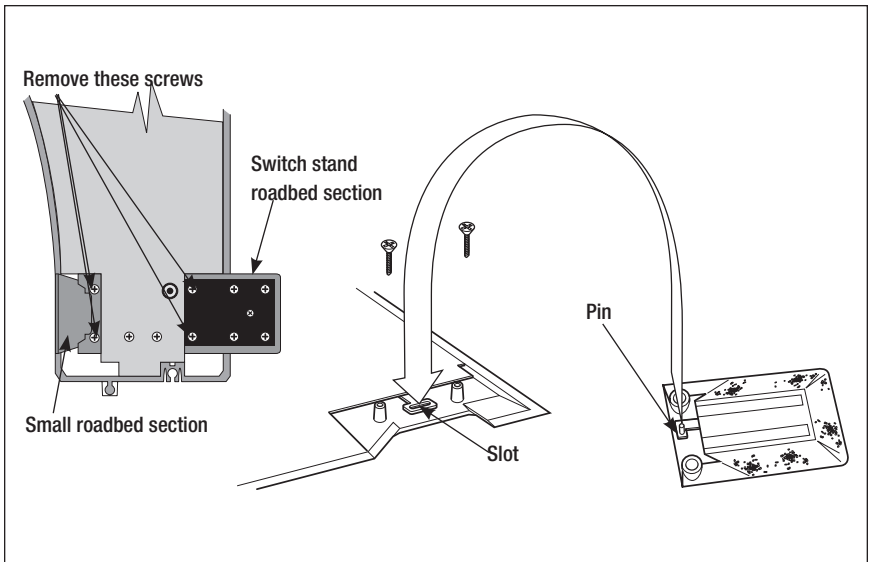

Figure 3. Switch stand installation

Routing the controller cable

The controller cable has been routed through the notch on the curved side of the roadbed at the factory. You may choose to route the controller cable through the notch on the straight side of the roadbed. As illustrated in Figure 4, remove the notch section from the straight side of the roadbed and bend the metal tabs to free the controller cable. Reroute the cable through the notch on the straight side of the roadbed. With the controller cable in place, bend down the metal tabs to hold the controller cable in the channel. Snap the notch section of roadbed provided separately with your switch to the curved side of the roadbed to hide the notch.

Note! Save the notch section from the straight side of the roadbed for future use.

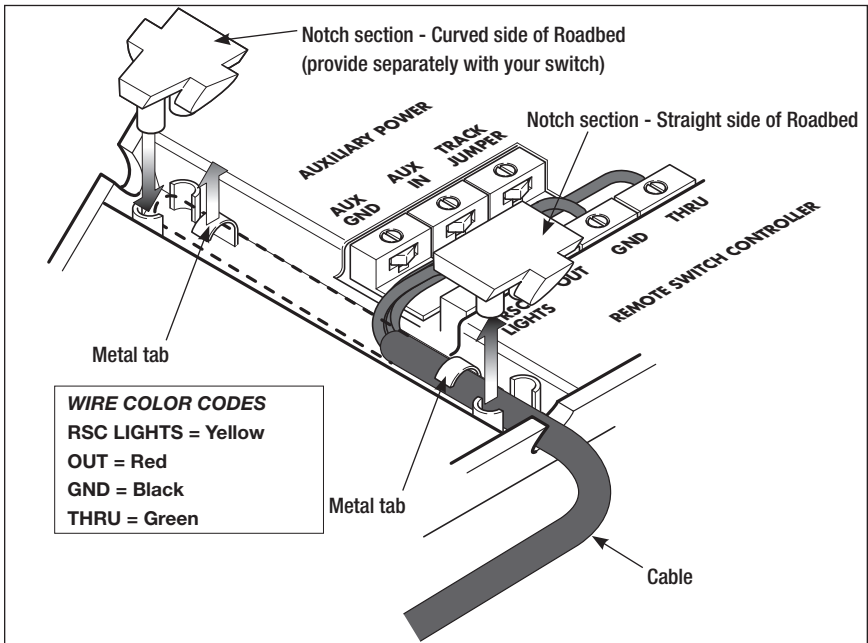

Figure 4. Controller cable

Mounting the controllers

If you have multiple switches and controllers, you may choose to snap the interlocking controller bases together and mount them to your control panel using screws. To join the controller bases, snap the bases together on a flat surface as illustrated in Figure 5. Drive screws through the holes in the controller bases to secure the controllers to your layout. We recommend using No. 4 sheet metal screws.

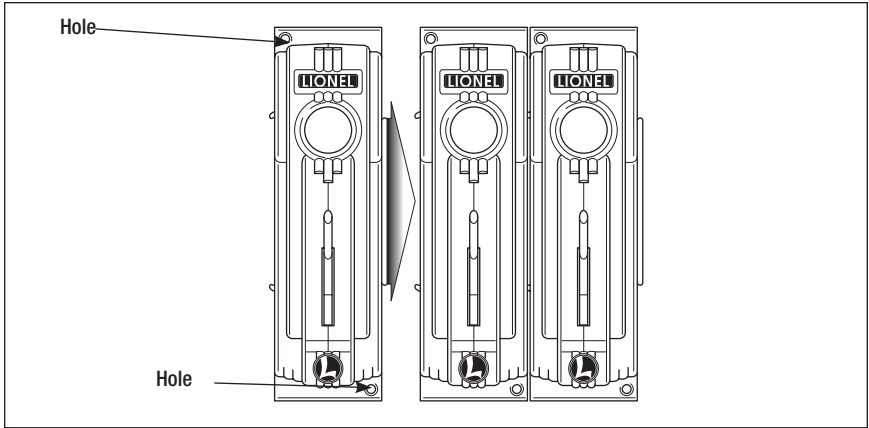

Figure 5. Joining the controllers

Numbering your switch controllers

You may choose to number your switch controllers to help you identify the switches on your layout. Six numbered lenses are included with your switch.

To number a switch, slide the logo lens out from under the left side of the frame, then insert the numbered lens. Refer to Figure 6.

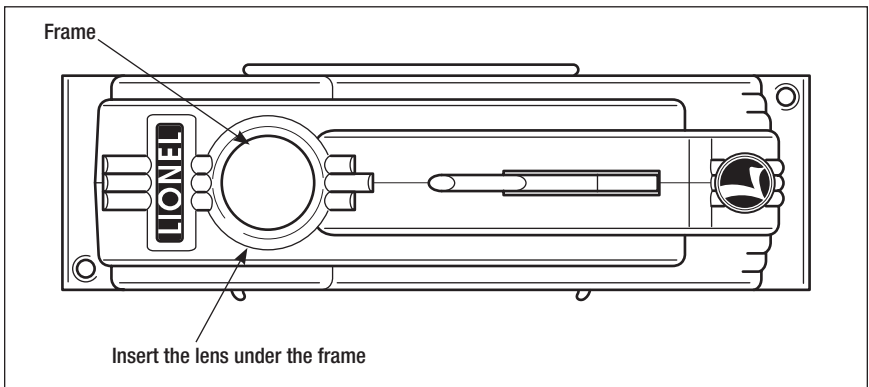

Figure 6. Inserting a numbered lens

Powering the switch through a separate power supply

You may choose to connect the switch to a separate power supply to operate the switch when track power is off or set to a low voltage. This is most beneficial to those operating in the conventional environment. The switch operates best at 5-18 volts (AC). Follow these steps and refer to Figure 7 to make the proper connections.

1. Remove the jumper between the TRACK JUMPER and AUX IN terminals on the underside of the switch. Loosen the terminal screws and slide out the jumper.

Note! We recommend that you save the track jumper in a safe place for reverting to track power in the future

2. Connect the Power/A terminal on your power supply to the AUX IN terminal on the switch.
3. Connect the Common/Ground/U terminal on your power supply to the AUX GND terminal on the switch.

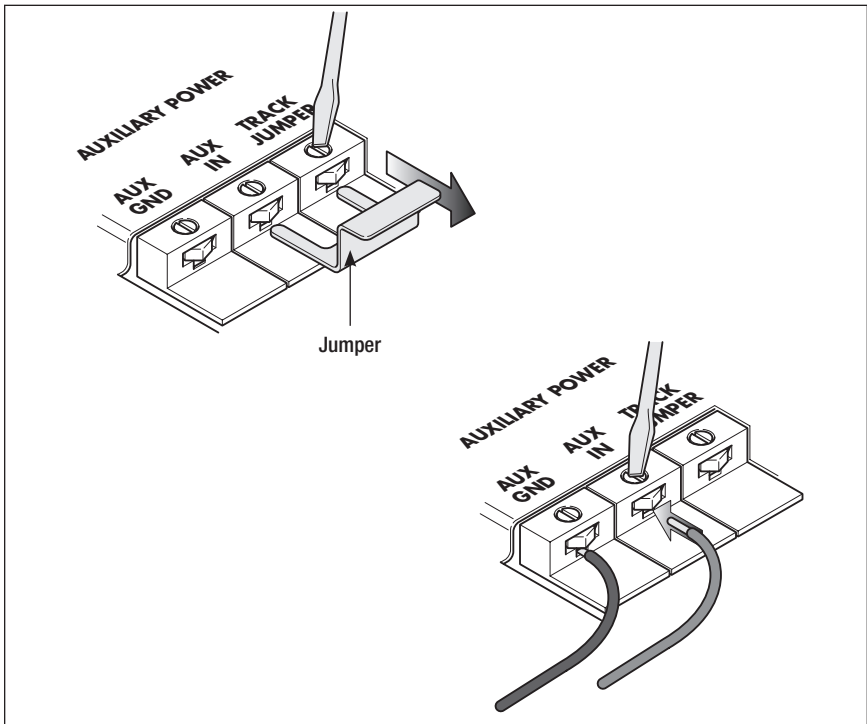

Figure 7. Power supply connections

Connecting the controller

The four controller wires are attached to the terminals on the underside of the switch. The controller wires were attached at the factory. The connections are as follows: green wire to THRU, black wire to GND, red wire to OUT, and yellow wire to RSC LIGHTS.

Operating the switch in the TrainMaster Command Control environment

You may choose to operate the switch in the TrainMaster Command Control environment using the Accessory Switch Controller (available separately, 6-14182) or the SC-2 Switch Controller (available separately, 6-22980). Refer to these manuals for additional information.

Note! You may choose to leave the controller attached to operate the switch without your CAB-1 Remote Controller.

ASC connections

The Accessory Switch Controller is capable of controlling up to four remote switches at a time. Wire the switches to the terminals on the back of the ASC unit as illustrated in Figure 8.

1. Attach a wire to the THRU terminal on the switch and connect it to the 1 T terminal on the ASC unit.
2. Attach another wire to the OUT terminal on the switch and connect it to the 1 O terminal on the ASC unit.
3. Attach the final wire to the GND terminal on the first switch and connect it to the COMM terminal to the right of the 1T and 1O terminals on the ASC unit.
4. Repeat this process for any additional switches, filling the empty switch terminals on the ASC in the same way.

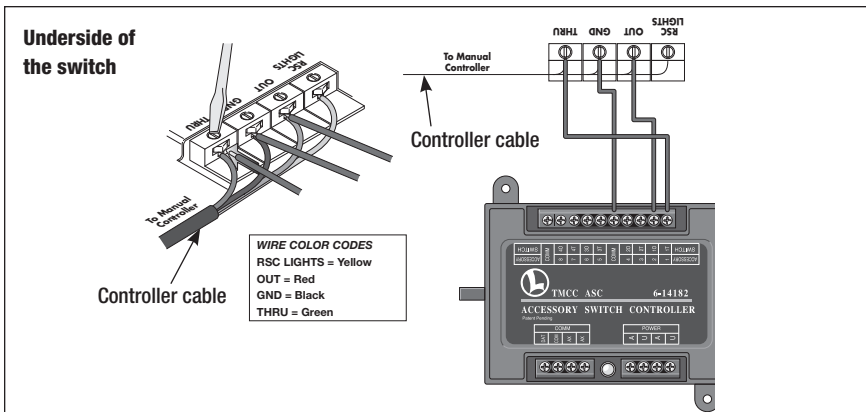

Figure 8. ASC connections

Operating the switch in the TrainMaster Command Control environment (continued)

SC-2 connections

The SC-2 is capable of controlling up to five remote switches at a time. Wire the switches to the terminals on the back of the SC-2 unit as illustrated in Figure 9.

Note! Do not connect your FasTrack switch to the #1 terminal on the SC-2.

1. Attach a wire to the THRU terminal on the switch and connect it to the THROUGH (single arrow) terminal on the SC-2 unit.
2. Attach another wire to the OUT terminal on the switch and connect it to the OUT (double arrow) terminal on the SC-2 unit.
3. Attach the final wire to the GND terminal on the first switch and connect it to the COMM (center) terminal on the SC-2 unit.
4. Repeat this process for any additional switches, filling the empty switch terminals on the SC-2 in the same way.

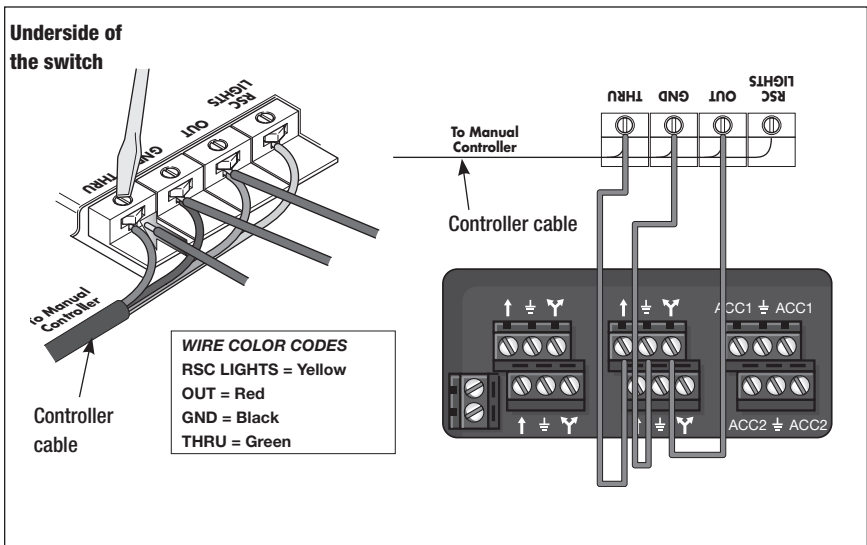

Figure 9. SC-2 connections

Servicing the lamps

Your switch lamp and switch controller are illuminated by several light emitting diodes (LEDs). The LEDs are expected to last for the life of the switch and are not user serviceable. See your authorized Lionel Service Center if your LEDs require service.

Lionel Limited Warranty Policy & Service

This Lionel product, including all mechanical and electrical components, moving parts, motors and structural components, with the exception of LIGHT BULBS & LED's are warranted to the original owner-purchaser for a period of **one year from the original date of purchase** against original defects in materials or workmanship when purchased through a **Lionel Authorized Retailer***.

This warranty does **NOT** cover the following: Normal wear and tear, Light bulbs or LED's, Defects appearing in the course of commercial use, or Damage resulting from abuse/misuse of the product.

Transfer of this product by the original owner-purchaser to another person voids this warranty in its entirety. Modification of this product in any way; visually mechanically or electronically, voids the warranty in its entirety.

Any warranted product which is defective in original materials or workmanship and is delivered by the *original owner-purchaser* (this warranty is non-transferrable) to Lionel LLC or any Lionel Authorized Service Station **MUST** be accompanied by the original receipt for purchase (or copy) from an **Lionel Authorized Retailer***, will at the discretion of Lionel LLC, be repaired or replaced, without charge for parts or labor. In the event the defective product cannot be repaired, and a suitable replacement is not available, Lionel will offer to replace the product with a comparable model (**determined by Lionel LLC**), if available. In the event a comparable model is not available the customer will be refunded the original purchase price (requires proof of purchase from the **Lionel Authorized Retailer*** it was originally purchased). Any products on which warranty service is sought must be sent freight or postage prepaid (Lionel will refuse any package when postage is due).

Transportation and shipping charges are not covered as part of this warranty.

NOTE: Products that require service that do not have a receipt from an LIONEL AUTHORIZED RETAILER* will be required to pay for all parts required to repair the product (labor will not incur a charge) providing the product is not older than 5 years from date of manufacture and is within 1 year from date of purchase. A copy of the original sales receipt is required.

In no event shall Lionel LLC be held liable for incidental or consequential damages.

Some states do not allow the exclusion or limitation of incidental or consequential damages, so the above exclusion may not apply to you.

This warranty gives you specific legal rights and you may have other rights which vary from state to state.

Instructions for Obtaining Service

If service for this Lionel LLC product is required; bring the item, along with your DATED sales receipt and completed warranty information (at the bottom of this page) to the nearest Lionel Authorized Service Station. Your nearest Lionel Service Station can be found by calling 1-800-4-LIONEL or by accessing the website at www.lionel.com.

If you prefer to send your Lionel product directly to Lionel, for repair you must **FIRST** call 586-949-4100 extension 9105 or FAX Lionel at 586-949-5429 or write to Customer Service, 50625 Richard W. Blvd, Chesterfield, MI 48051-2493. Please have the 6-digit Lionel product number, the date of original purchase, the dealer where the item was purchased and what seems to be the problem. You will receive a Verbal return authorization (RA) number to ensure your merchandise will be properly tracked and handled upon receipt at Lionel LLC.

Once you have your Return Authorization (RA) number, make sure the item is packed in its original Styrofoam inner container which is placed inside the original outer display box (this will help prevent damage during shipping and handling). This shipment **MUST** be prepaid and we recommend that it be insured with the carrier of your choice.

Please make sure you have followed all of the above instructions carefully before returning any merchandise for service. You may choose to have your product repaired by one of Lionel LLC's Authorized Service Stations after its warranty has expired. A reasonable service fee should be expected once the product warranty has expired.

Warranty Information

Please complete the information below and keep it, along with your **DATED ORIGINAL SALES RECEIPT**. You **MUST** present this form **AND** your **DATED SALES RECEIPT** when requesting warranty service.

*A complete listing of Lionel Authorized retailers can be found by calling 1-800-4-LIONEL or by visiting our website at www.lionel.com.

Products that are more than 5 years old, from date of manufacture, are not applicable for warranty coverage, even if they have never been sold prior to this date. (Under no circumstance shall any components or labor be provided free of charge.)

Name _____

Address _____

Place of Purchase _____

Date of Purchase _____

Product Number _____

Product Description _____

