

CEMENT TEST EQUIPMENT, INC.

TULSA, OKLAHOMA, USA

Liquid / Gas Core
Permeameter
Instruction Manual

CEMENT TEST EQUIPMENT, INC.

Core Permeameter User's Manual

© 2013 Test Equipment, Inc.
5704 E. Admiral Blvd.
Tulsa, OK 74115
Phone 918-835-4454 • Fax 918-835-4475

Table of Contents

INTRODUCTION	1
Uses of a Core Permeameter	1
Description of the Instrument	1
Instrument Specifications	2
Installation	2
OPERATION AND CALIBRATION	4
Preparing the Cement Core Sample	4
Operating the Core Permeameter with Water	4
Calculating Liquid Permeability	6
Operating the Permeameter with Gas	7
Calculating Gas Permeability	7
MAINTENANCE, SERVICING, AND TROUBLESHOOTING	9
Maintenance	9
General Maintenance	9
PLUMBING DIAGRAM AND FLOW TABLES	11

Introduction

This chapter contains general information about the atmospheric consistometer and its uses as well as detailed specifications for the instrument.

Uses of a Core Permeameter

Cements are a critical element in the drilling, completion, work over, and abandonment of wells. For each application, a cement slurry is designed with specific properties and is given additives that provide predictable slurry density, volume, viscosity, compressive strength, fluid loss, gas migration, and thickening time. The core permeameter is typically used in permeability testing to achieve a greater understanding of the slurry design. The typical test methods are listed in API Specification 10B-2.

Description of the Instrument

The Model 3020 Permeameter is able to test cement core samples at room temperature and maximum pressures of 200psi (1.4Mpa) for liquids and 500psi (3.5Mpa) for gasses. The CTE Model 3020 Core Permeameter consists of the following primary components:

1. Pressure Vessel containing rubber core holder insert.
2. Gas inlet to be used with Air or Nitrogen service at a maximum pressure of 2500psi (174Mpa).
3. Water inlet for water permeability testing.
4. Accumulator for increasing water pressure up to 200psi (1.4Mpa).
5. Flow meter for recording flow of fluid through cement sample.
6. Water / Air testing selection valve.
7. Exhaust valve.
8. Water shutoff valve.

The CTE Model 3020 is designed only to be used with API specification standard cored cement samples. These samples must be 1.0in (25.4mm) in diameter and 1.0in (25.4mm) in length to properly fit in the sample container. Using samples of sizes other than that specified is not recommended and may be a serious safety hazard.

Instrument Specifications

MECHANICAL

Height:	17 in. (43 cm)
Width:	12 in. (29 cm)
Depth:	14 in. (35 cm)
Weight:	24 lb. (11 kg)

ENVIRONMENTAL

Operating Temperature:	(32 to 105°F) 0-40°C
Operating Humidity:	0-95% non-condensing

UTILITIES – COOLING WATER

Nitrogen (N ₂) or Air:	2500psig (17000 bar) maximum
Cooling Water Pressure:	100 psig (6.8 bar) maximum
Utility Inlets:	¼ inch female NPT

Installation

Upon uncrating the instrument, verify that the instrument and any spare parts on the packing have been received and are undamaged. Notify CTE if anything is missing or damaged.

Locate the instrument on a firm level surface. Once the instrument has been moved to its desired location, water, drain, and air connections can be made. The water inlet, drain, and air inlet are located on the lower right side of the instrument. All connections are ¼ female NPT. The drain and water connections may be made with either metal or plastic tubing.

OPERATION AND CALIBRATION

If not installed at the factory, the rubber cement holder can be inserted into the pressure vessel. Be sure to apply a thin coat of grease to all sides of the rubber sample holder before installation. The base of the pressure vessel can then be placed in the holder located at the front of the instrument. The outlet connection at the bottom of the holder should be secured to ensure leak-free operation. The lid of the pressure vessel should remain off until the core sample is put into place. Use the included copper based anti-seize on the threads of the pressure vessel to prevent galling. Before operating the instrument, it is a good idea to check for loose screws or bolts that may have loosened and fallen out during shipment. This is particularly true for overseas shipments.

Operation and Calibration

Chapter 2 will discuss in detail the steps required to operate and calibrate the instrument. These steps are similar to those in API RP 10B-2 Chapter 11.

The permeameter is very easy to use. To operate the instrument, simply follow the steps listed below.

Preparing the Cement Core Sample

1. Cure the cement slurry in suitable mould as per API specifications.
2. Core the cured cement sample with a 1.0in (25.4mm) ID diamond core drill. The resulting core sample should be cut to a length of 1.0in (25.4mm).
3. Clean the ends of the core sample to remove any residue. Ensure that the sample is of the proper dimensions listed above before placement into the sample holder.
4. Push the core sample into the 1.0in (25.4mm) diameter hole in the rubber sample holder which should be already placed securely into the pressure vessel base.
5. Ensure that the plastic tube is securely connected into the push-on fitting in the bottom of the pressure vessel.
6. Place the lid of the pressure vessel on and screw down until suitably tight. The lid should not need to be tightened excessively and there should be approximately .1-.3in (2.5-7.5mm) clearance between the lid and the pressure vessel top. Typically a bench mounted vise and a strap wrench is used to tighten the assembly.
7. Connect the supplied tube connection from the top of the pressure vessel to the pressure outlet on the front of the instrument.

Operating the Core Permeameter with Water

1. Ensure that all connections are tight and the cement core sample is secured in the pressure vessel as described above.
2. Turn valves A/B, C, and D to the OFF position.
3. With the regulator turned completely counter-clockwise (closed position) apply air pressure to gas/air inlet.

OPERATION AND CALIBRATION

4. Locate the silver colored stainless steel accumulator tank at the back of the permeameter.
5. Locate the cap fitting at the top of the accumulator tank.
6. Slightly loosen the cap at the top of the fitting.
7. Apply water pressure to the instrument through the supplied water inlet connection and open the inlet water valve F.
8. Fill the accumulator tank until water can be seen coming out the top and then tighten the cap.
9. Close the water inlet valve F.
10. Move Valve A/B to the B (water) position.
11. Open Bleed Valve D.
12. Slowly open valve C
13. Slowly increase air pressure as observed on gauge G, with regulator until a steady stream of water begins to flow out of valve D.
14. Close valve D to divert the water through the cement core sample.
15. Ensure the flow meter knob is turned fully counter-clockwise or fully open for free-flow.
16. Increase pressure on regulator to desired test pressure.
17. Allow small amount of water to flow through flow-meter before recording the flow. Allow flow to stabilize.
18. Record the flow over time in milliliters per second. Use the lowest possible flow rate / pressure for most accurate measurements.
19. Refer to API RP 10B-2 for further information and results analysis.
20. When test is completed, decrease pressure on regulator to 0, open valve D and allow all pressure to be released. Close valves A/B and C. Close valve D after ALL PRESSURE IS OUT OF SYSTEM.
21. Disconnect top and bottom tube connections to the pressure vessel.
22. Remove rubber holder and core sample using the supplied hand-driven air pump as shown in Figure 1. Remove top plug and then apply air pressure to the bottom side of the pressure vessel. This small amount of air pressure breaks the seal on the rubber holder and gently pops out of the pressure vessel.
23. Clean pressure vessel and reapply anti-seize as necessary.



Figure 1

Calculating Liquid Permeability

Calculating liquid permeability with Darcy's Law

$$K(\text{md}) = 14700 \frac{Q \times \mu \times L}{A \times \Delta P}$$

K (md) = millidarcy; permeability.

μ (cps) = centipoise also abbreviated as cp; viscosity of liquid. Water is usually somewhere close to 890 cp depending on temperature.

Q (mL/sec) = liquid flow rate. Read the location of the ball in the middle and then use the flow table located at the end of the operation manual to determine the flow rate.

1 CCM = 1 cm³/min = 1 mL/min. divide by 60 sec to get mL/sec.

L (cm) = cement sample length.

A (cm²) = cross sectional area of cement sample ($A=\pi r^2$).

P_i (psia) = inlet pressure; add 14.7 to psig to get psia.

P_o (psia) = outlet pressure; add 14.7 to psig to get psia.

Operating the Permeameter with Gas

1. Turn valves A/B, C, D, and F to the OFF position.
2. Ensure that all connections are tight and the cement core sample is secured in the pressure vessel as described above.
3. Apply gas to the gas/air inlet.
4. Move Valve A/B to the A position.
5. Open Valve D and allow a small amount of air into the drain through valve D.
6. Close valve D to divert the gas through the cement core sample.
7. Ensure the flow meter knob is turned fully counter-clockwise or fully open for free-flow.
8. Increase pressure on regulator to desired test pressure.
9. Allow small amount of air to flow through flow-meter before recording the flow.
10. Record the inlet pressure from the pressure gauge and the mm location at the center of the ball. Use the lowest possible flow rate / pressure for most accurate measurements.
11. Refer to the next section Calculating Gas Permeability and API RP 10B-2 for further information and results analysis.
12. When test is completed, decrease pressure on regulator to 0, open valve D and allow all pressure to be released. Close valves A/B and C. Close valve D after ALL PRESSURE IS OUT OF SYSTEM.
13. Disconnect top and bottom tube connections to the pressure vessel.
14. Remove rubber holder and core sample using the supplied hand-driven air pump as shown in Figure 1. Remove top plug and then apply air pressure to the bottom side of the pressure vessel. This small amount of air pressure breaks the seal on the rubber holder and gently pops out of the pressure vessel.
15. Clean pressure vessel and reapply anti-seize as necessary.

Calculating Gas Permeability

Calculating gas permeability using Darcy's Law

$$K(md) = \frac{2000 \times \mu \times Q_b \times P_b \times L}{A(P_i^2 - P_o^2)}$$

OPERATION AND CALIBRATION

K (md) = millidarcy; permeability to gas.

μ (cps) = centipoise also abbreviated as cp; viscosity of gas. Air is usually somewhere close to 0.018698 cp depending on temperature.

Q_b (mL/sec) = gas flow rate. Read the location of the ball in the middle and then use the flow table located at the end of the operation manual to determine the flow rate.

1 CCM = 1 cm³/min = 1 mL/min. divide by 60 sec to get mL/sec.

P_b (atm) = adjusted barometric pressure. Local barometric pressure is usually given in inches of mercury and can be converted to atmospheres.

L (cm) = cement sample length.

A (cm²) = cross sectional area of cement sample ($A=\pi r^2$)

P_i (atm) = inlet pressure; add 14.7 to psig pressure to get psia and then divide by 14.7 to get atmospheres.

P_o (atm) = outlet pressure; usually 1 atm or P_b .

Maintenance, Servicing, and Troubleshooting

This chapter contains information about the necessary periodic maintenance of the instrument as well as common service and troubleshooting guidelines.

Maintenance

Permeameters can be relatively reliable and trouble free—provided they are serviced and maintained properly. Instruments that are neglected and receive infrequent service or are subject to abuse are certain to cause trouble.

General Maintenance

The instrument requires very little general maintenance. The small amount of maintenance that is required is listed below.

1. If the rubber sample holder in the pressure vessel becomes dirty or contaminated with cement, it should be replaced.
2. Thoroughly clean the pressure vessel after each use to remove all traces of cement / grease.
3. Lubricate the rubber sample holder in the pressure vessel with grease before each use.
4. Apply anti-seize the threads of the pressure vessel.

MAINTENANCE, SERVICING, AND TROUBLESHOOTING

The following is a table of frequently used replacement parts along with the CTE part numbers.

Description	Part Number
¼ Turn Brass Valve	C-0056-1
Three way valve	C-0122
Pressure Vessel	23-0011
Pressure Vessel Top Plug	23-0012
Rubber Sample Holder	23-0013
Elbow, ¼ MNPT x ¼ Tube	C-0054
Connector, 1/8 MNPT x ¼ Tube	C-0057
Flow meter	C-0577-1
500 psi Pressure Regulator	C-0623-4
Pressure Gauge, 600psi	C-0625-1
Air pump	C-0355
Shrader valve	C-1338
Connector, 1/8" FNPT x ¼" Tube	C-0187



Plumbing Diagram and Flow Tables

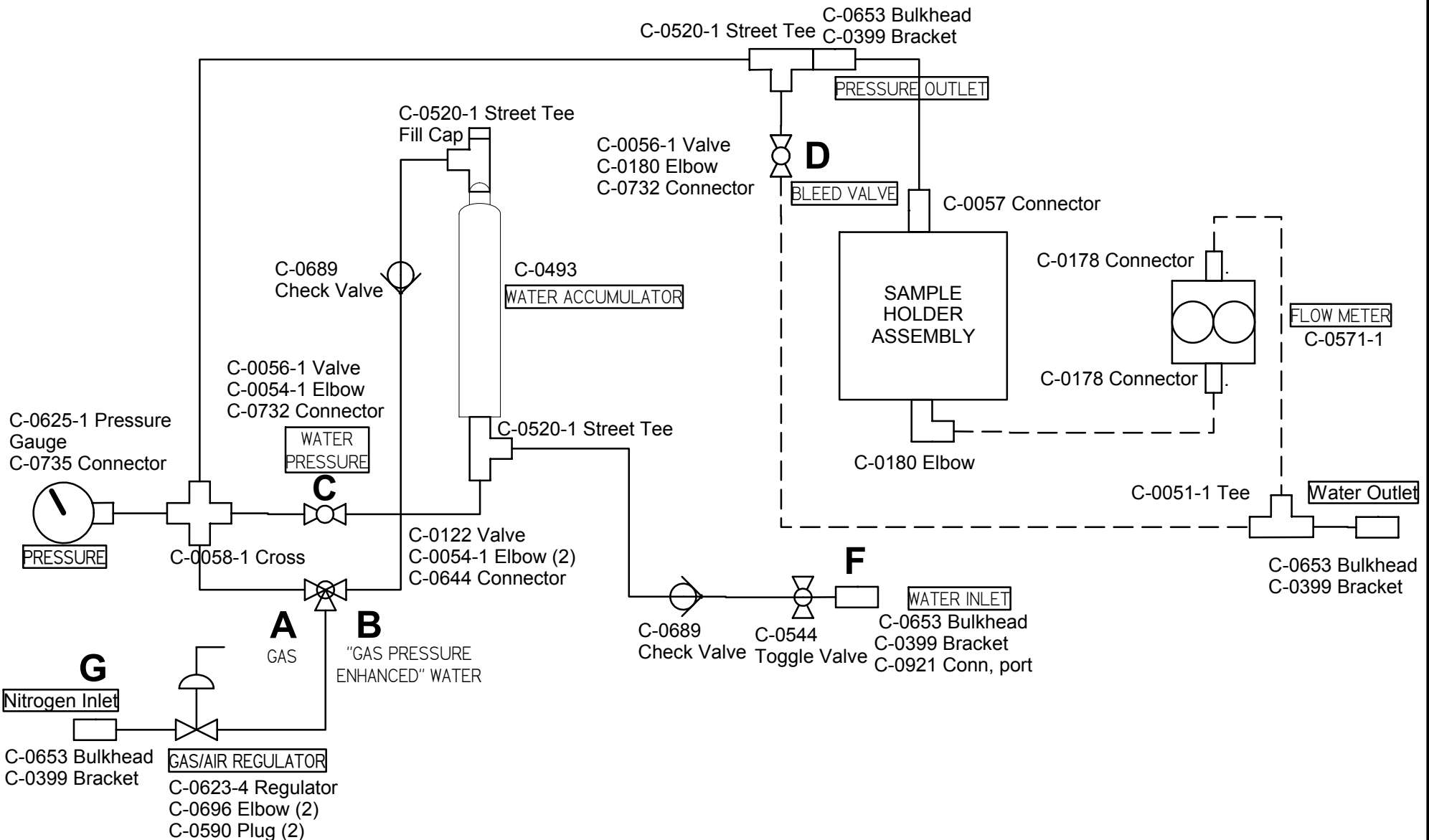

G
Nitrogen Inlet
C-0653 Bulkhead
C-0399 Bracket

A
GAS
"GAS PRESSURE ENHANCED" WATER

B
GAS/AIR REGULATOR
C-0623-4 Regulator
C-0696 Elbow (2)
C-0590 Plug (2)

C
WATER PRESSURE
C-0625-1 Pressure Gauge
C-0735 Connector
C-0058-1 Cross
C-0056-1 Valve
C-0054-1 Elbow
C-0732 Connector
C-0689 Check Valve

REVISION	UPDATED AND ADDED ITEMS
REV A: GRH	

UNLESS OTHERWISE SPECIFIED DIMENSIONS ARE IN INCHES TOLERANCES ARE: FRACTIONS DECIMALS ANGLES		CAD GENERATED DRAWING, DO NOT MANUALLY UPDATE	
$\pm 1/32$.XX	$\pm .01$	
	.XXX	$\pm .005$	
APPROVALS		DATE	
DRAWN CCD		9-21-12	
CHECKED			
RESP ENG CCD		9-21-12	
MFG ENG			
QUAL ENG			

CEMENT TEST EQUIPMENT, INC.			
PIPING SCHEMATIC CEMENT PERMEAMETER			
SIZE D	DWG. NO. 23-0004	REV. A	
SCALE	CAD FILE:	SHEET 1 OF 1	

Part Number : 10410_R5

LOCATION	AIR	WATER	OXYGEN	NITROGEN	ARGON	CO ₂	HELIUM
MM	CCM	CCM	CCM	CCM	CCM	CCM	CCM
2	23.4	0.34	14.1	20.0	19.9	17.7	20.3
4	28.4	0.38	18.2	25.0	24.2	23.2	21.3
6	33.8	0.43	22.8	30.8	28.7	29.3	33.3
8	39.5	0.50	27.9	37.0	33.6	35.9	38.4
10	45.7	0.58	33.6	43.6	38.8	43.1	43.5
12	52.2	0.68	39.8	50.7	44.4	51.2	49.2
14	59.3	0.78	46.7	58.4	50.4	60.1	56.1
16	66.9	0.88	54.1	66.8	56.8	70.0	64.2
18	75.1	0.99	62.1	76.0	63.8	80.7	73.4
20	84.0	1.10	70.8	86.0	71.4	92.2	83.4
22	93.6	1.21	80.0	96.8	79.6	104	93.8
24	104	1.33	89.9	108	88.4	117	105
26	115	1.45	100	121	98.0	129	116
28	127	1.58	111	134	108	142	127
30	140	1.71	123	147	119	154	139
32	153	1.86	134	161	130	167	152
34	167	2.00	146	175	142	179	165
36	182	2.16	159	189	154	192	179
38	196	2.32	171	203	166	204	193
40	210	2.49	184	217	179	216	208
42	224	2.66	197	231	191	227	224
44	238	2.85	210	245	203	239	241
46	252	3.04	223	259	215	250	258
48	266	3.24	236	273	226	262	275
50	280	3.45	249	287	238	273	294
52	293	3.67	262	300	249	284	313
54	306	3.90	274	314	260	295	333
56	319	4.13	287	327	271	306	353
58	332	4.38	300	341	282	316	373
60	345	4.63	312	354	293	327	395
62	357	4.88	325	367	304	338	417
64	370	5.14	337	380	314	348	439
66	382	5.41	349	393	325	358	462
68	395	5.68	361	406	335	369	485
70	407	5.96	373	418	346	379	509
72	419	6.24	385	431	356	389	533
74	432	6.52	397	443	367	399	557
76	444	6.81	408	456	377	409	582
78	456	7.10	420	468	388	419	608
80	468	7.39	432	480	398	429	633
82	480	7.68	443	493	408	439	660
84	492	7.97	454	505	418	448	686
86	504	8.26	466	517	429	458	713
88	516	8.55	477	529	439	468	740
90	528	8.85	488	541	449	477	767
92	540	9.14	499	552	459	487	795
94	552	9.43	510	564	469	497	823
96	563	9.72	521	576	479	506	851
98	575	10.0	531	588	488	516	879
100	586	10.3	542	599	498	525	907
102	598	10.6	553	611	508	534	935
104	609	10.9	563	622	518	544	963
106	620	11.2	574	634	527	553	992
108	631	11.4	585	645	537	563	1020
110	642	11.7	595	657	546	572	1048
112	653	12.0	606	668	555	581	1077
114	665	12.3	616	679	565	590	1105
116	675	12.6	626	690	574	600	1133
118	686	12.9	637	702	583	609	1161
120	697	13.1	647	713	593	618	1188
122	708	13.4	657	724	602	627	1216
124	719	13.7	668	735	611	636	1243
126	730	14.0	678	746	620	646	1271
128	741	14.2	688	757	630	655	1298
130	751	14.5	698	768	639	664	1324
132	762	14.8	708	779	648	673	1351
134	773	15.1	719	790	657	682	1377
136	784	15.3	729	800	666	691	1403
138	794	15.6	739	811	675	700	1429
140	805	15.9	749	822	684	709	1455
142	815	16.1	759	833	693	718	1480
144	826	16.4	769	843	702	727	1505
146	836	16.7	779	854	710	736	1530
148	846	16.9	789	865	719	745	1555
150	855	17.2	800	875	727	754	1579

Float :	DIAMETER: 1/8 IN.	MATERIAL: GLASS	Operating Conditions:	68F	14.696 PSI	Vertical	Tube Identification:	1G04 R5
	WEIGHT: 0.0421 GRAMS	COLOR: BLACK		(20°C)	(1.013 Bar)	Installation		

For operating conditions other than those indicated above please consult factory.

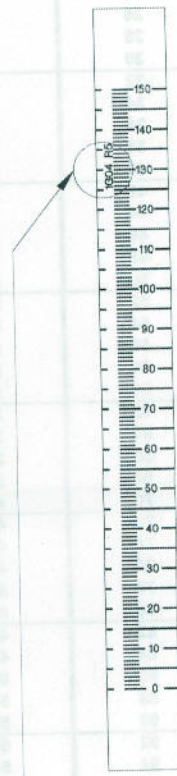
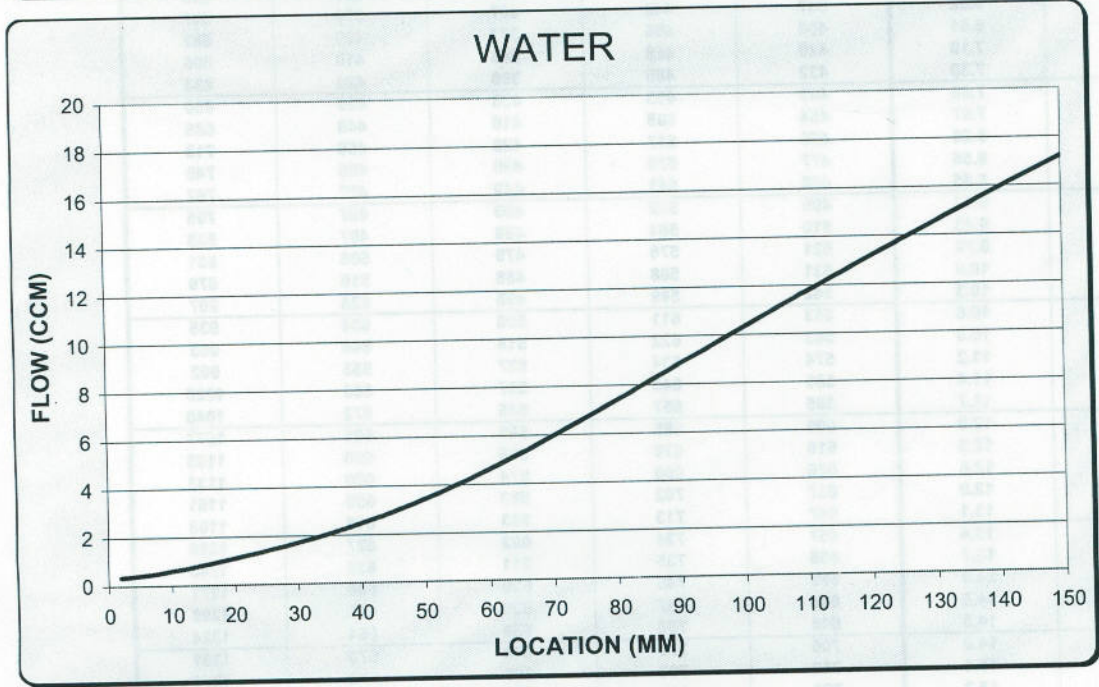
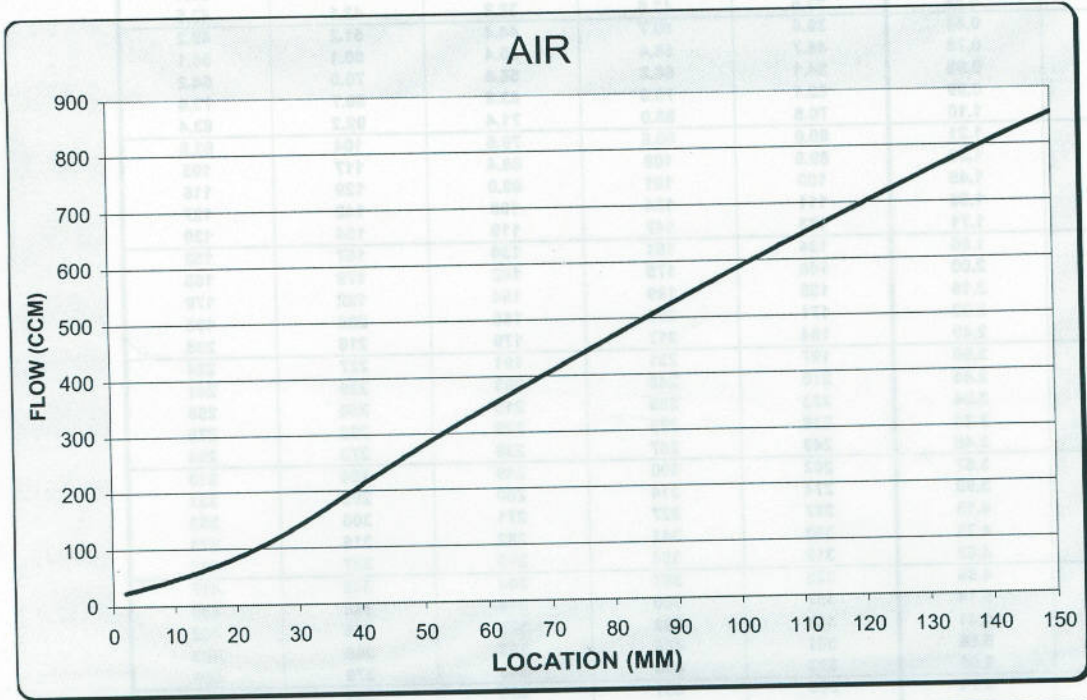

TUBE ID AND REVISION LEVEL INDICATOR

SPECIFICATIONS	
ACCURACY:	± 5% Full Scale - 65 mm ± 3% Full Scale - 150 mm
FLOATS:	Black Glass Ball Float Sapphire Ball Float Stainless Steel Ball Float Tungsten Carbide Float Tantalum Float
FRAME BACKPLATE:	Anodized Aluminum
END BLOCKS AND ELASTOMERS:	Aluminum with Buna-N Brass with Buna-N Stainless Steel with Viton®
FITTINGS:	1/4-27 FNPT Fittings
GLASS TUBE:	Precision Formed Borosilicate Glass
MAXIMUM TEMPERATURE:	200°F (93 °C)
MAXIMUM PRESSURE:	200 PSI (13.8 Bar)

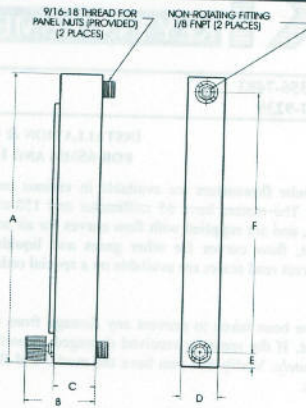

Tube Length	A	B	C	D	E	F
65 MM	5 1/2	2 5/16	1 5/16	1 1/4	1/2	4 1/2
150 MM	9 13/16	2 5/16	1 5/16	1 1/4	1/2	9 13/16

FIGURE 1

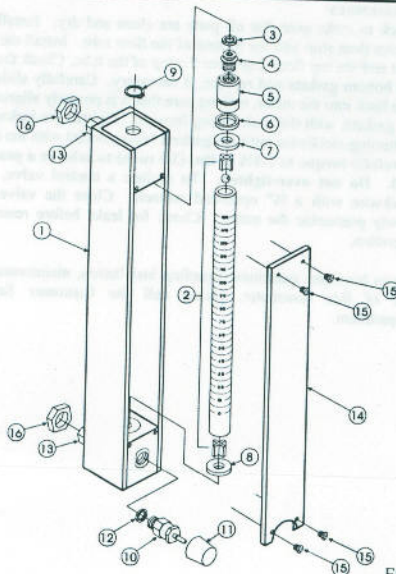

FIGURE 2

Number	Description
1	Frame Assembly
2	Tube Assembly
3	Jack Screw O-ring
4	Jack Screw
5	Jack Plug
6	Jack Screw O-ring
7	Top Gasket
8	Bottom Gasket
9	Retaining Clip
10	Optional Valve
11	Valve Knob
12	Valve O-ring
13	Fitting
14	Lens
15	6/32 screw
16	Panel Nuts

CONTINUED PRODUCT IMPROVEMENT MAY RESULT IN SPECIFICATION REVISIONS
WHEN ORDERING PARTS PLEASE INCLUDE PART DESCRIPTION, ITEM NUMBER AND TYPE OF MATERIAL REQUIRED.

IDT142 REV. 3