

LITERATURE

GRADIENT CONTROL MAT (GCM)



DAIRYLAND
ELECTRICAL INDUSTRIES

ALWAYS RUGGED. ALWAYS RELIABLE.



INTRODUCTION

The gradient control mat by Dairyland is designed to limit step and touch potentials due to lightning because such design will also keep step and touch potentials well below that required by IEEE 80 for power frequency voltages. The gradient control mat is made of 0.135" diameter steel wire with a 3" x 3" wire spacing with all wire intersections welded. After welding, the mat is hot dip galvanized. Mats are available in 4' x 8' sheets and are shipped flat on pallets. Each mat weighs 15 pounds (6.8kg). For larger mats, these sheets can be joined together to form any size mat required. Provision is made for thermit welding adjacent mat sections together to form an electrically continuous mat and for thermit welding lead connections to the mat.

Design Life

To assure long life of the galvanized steel gradient control mat in all soil conditions, Dairyland commissioned Correng Consulting to provide guidelines for cathodically protecting the mat using readily available magnesium anodes. The design life of the anodes protecting the mat is 20 years. Refer to the Correng Report COR-05-9508D "Guidelines for Cathodic Protection of Galvanized Steel Gradient Control Mats," a supplement to this document. In this report, see Table 2 to: (a) select the desired mat size, (b) to determine the anode type and quantity required for the soil resistivity and the size mat selected, and (c) to determine the mat layout configuration that applies (Figure 1, 2, 3, or 4). Any larger size mat can be made from combining the sizes shown. The anodes required are to be purchased separately by the user from the supplier of choice per the criteria in Section 2.1 and 2.2 of the report. The anodes are to be ordered with the #6 AWG copper conductor size specified because this is required for connecting the anode lead to the mat with the thermit welding molds available from Dairyland for this purpose.

Installed Costs

Although auxiliary anodes and a decoupler are recommended, the total installed cost of the galvanized steel mat will normally be less than a pure zinc mat of any construction, particularly when an 8' x 8' or larger mat is required.

Safe Touch and Step Potentials

Specific technical data is provided for the touch and step potentials for the most difficult voltages to control, namely, voltage caused by lightning. Refer to Table 1 in Dairyland Application Note 8: Gradient Control Mats in Pipeline Applications for more information.

WARNING

KEEP THE CONDUCTORS SHORT!

The most significant installation factor is to keep the conductor that connects the mat to the pipeline as short as possible, preferably 8" (200 mm) or less, whether the mat is direct connected to the pipeline or connected through a Dairyland solid-state decoupler.

Decoupling

While the Dairyland gradient control mat may be directly connected to the pipeline or decoupled, it is recommended that the mat be connected to the pipeline through a Solid-State Decoupler (SSD) developed by Dairyland. A decoupled gradient control mat offers several distinct advantages:

- The galvanic potential of the mat material is irrelevant when it is decoupled from the cathodically protected pipeline
- CP readings can be taken in the vicinity of the gradient control mat
- Stray DC currents are prevented from accessing the pipeline, thereby preventing a corrosion problem where stray DC currents would exit the pipeline
- Any interaction between the CP system and the gradient control mat functions are eliminated
- When the mat is directly connected, the service life of the anodes is reduced by approximately 36% for the H1-Alloy magnesium anodes and 28% for the Hi-Potential magnesium anodes; hence, considerably longer anode life is achieved with a decoupled mat.



ORDERING INFORMATION

1. Gradient Control Mat (4' x 8'):

Order #GCM4-8. Specify quantity.

2. Anodes Required:

Order from supplier of choice per Table 2 and Section 2.1 and 2.2 of the Correng Report referenced in this document.

3. Decoupler:

For most applications, the SSD model suggested is SSD-2/2-1.2-100 which blocks +/- 2.0 volts (hence, polarity is not an issue when installing), has a 1.2kA fault current rating at 30 cycles, and a 100kA lightning current rating (8x20 µsec). Decouplers with higher AC fault and lightning current ratings are also available - See the SSD technical literature. Specify model number and quantity. If utilizing pin brazing for SSD mounting the SSD must have terminals oriented as shown in Figure 3, which is any SSD model without the "-R" ending to the catalog number.

For large station mats, it is suggested that connections to the gradient control mat be made at the incoming and outgoing pipelines. Other pipe segments within a station may also need to be referenced to ground through additional decouplers.

4. Thermit Welding Mold:

For mechanically and electrically bonding adjacent mat sections together and bonding the #6 AWG decoupler and anode conductors to the mat wire, order Mold-6X. This mold uses an industry standard #25 CP cartridge.

It is recommended that mats be joined approximately every 18 inches (450mm).

The life of the above mold is estimated at 50 welds nominal, 100 welds maximum.

All thermit welded decoupler and anode conductors to the mat, plus all thermit welded connections to join adjacent mats, should be completely sealed. A recommended sealant is the Denso LT tape available in 2" wide x 33' long rolls, available from Dairyland or the distributor of choice. About a 4" length of this tape is required to seal each connection. Other user provided equivalent sealants may also be used.

5. SSD Decoupler Mounting Options:

- a. Banding may be utilized as illustrated on sheet 2 of attached drawing 100103. The banding is to be purchased by the user.

This mounting option requires that conductors be run from one decoupler bus to the pipeline and from the other decoupler bus to the mat. Two conductors to each bus are recommended for a total of four conductors. The MTL conductor kit is available as an option. See separate MTL literature. Bolts, nuts, and washers for securing the terminal end of the conductor to the SSD bus are furnished with the SSD.

Order the mold and weld metal in Item 4 for welding the conductors to the mat. The user is responsible for the conductor connection to the pipeline. All conductors should be cut to the shortest possible length during installation to minimize touch potential.

- b. Attachment via pin brazing M8 studs to a steel pipe is illustrated in sheet 3 of attached drawing 100103. If utilizing pin brazing for SSD mounting, the SSD must have terminals oriented as shown, which is any SSD model without the "-R" ending to the catalog number. The user must have the required pin brazing equipment and consumable items (i.e., the M8-1.25 threaded studs with a 16mm threaded section furnished with two washers and a locknut and ceramic ferrules). Equipment and studs are available from several manufacturers - contact Dairyland for assistance if required. The desirability of this option is that it virtually eliminates the inductance of one conductor connection because one SSD terminal is directly connected to the pipe via the pin brazed stud. This in turn reduces the voltage due to lightning between the pipe and mat. For each decoupler installed using pin brazed stud mounting, order one #HCN-M8 (the Hex Coupling Nut plus M8 bolt and washers required) plus one set of conductors (MTL Kit).

ORDERING CHECKLIST:

1	Gradient Control Mat (GCM 4-8)
2	Anodes (Selected by user, per Correng Report)
3	Decoupler (SSD-2/2-1.2-75 Typical)
4	Thermit Welding Molds/Charges (Mold 6X)
5	Denso LT Tape (2"x33' roll)
6	Decoupler Mounting Options (See previous section)

Note: This drawing to be used in combination with Gradient Control Mat installation instructions

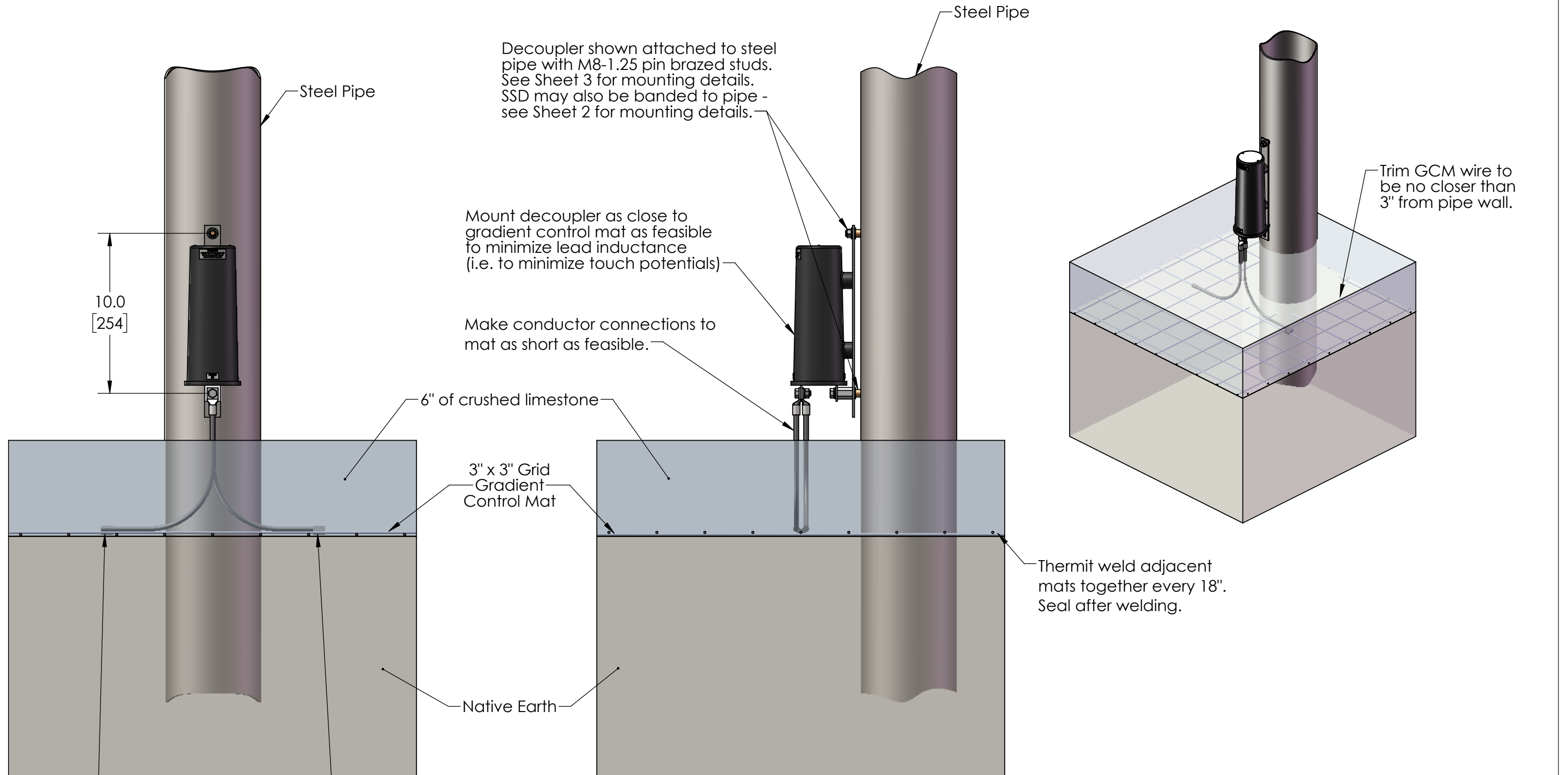

Thermit weld #6 Awg. decoupler conductors and anode conductors to mat. Seal after welding.

ANSI Y14.5M 1994 APPLIES
 UNLESS NOTED UNITS: INCHES
 3-PLACE: ±.005
 2-PLACE: ±.015
 1-PLACE / FRAC: ±.03
 ANGULAR: ±1



DAIRYLAND ELECTRICAL INDUSTRIES, INC.
 P.O. BOX 187
 STOUGHTON, WI 53589
 608-877-9900
 DAIRYLAND.COM

DESCRIPTION Decoupling of Gradient Control Mat: Typical Installation				
DOCUMENT #	REV	DATE DRAWN	DWG SIZE	DATE APPROVAL
100103	A	2017-02-20	B	2017-02-24
SCALE 1:6	DRAWN: JPW	SHEET: 1 OF 3	DWG APPROVAL: JWV	

Note: This drawing to be used in combination with Gradient Control Mat installation instructions

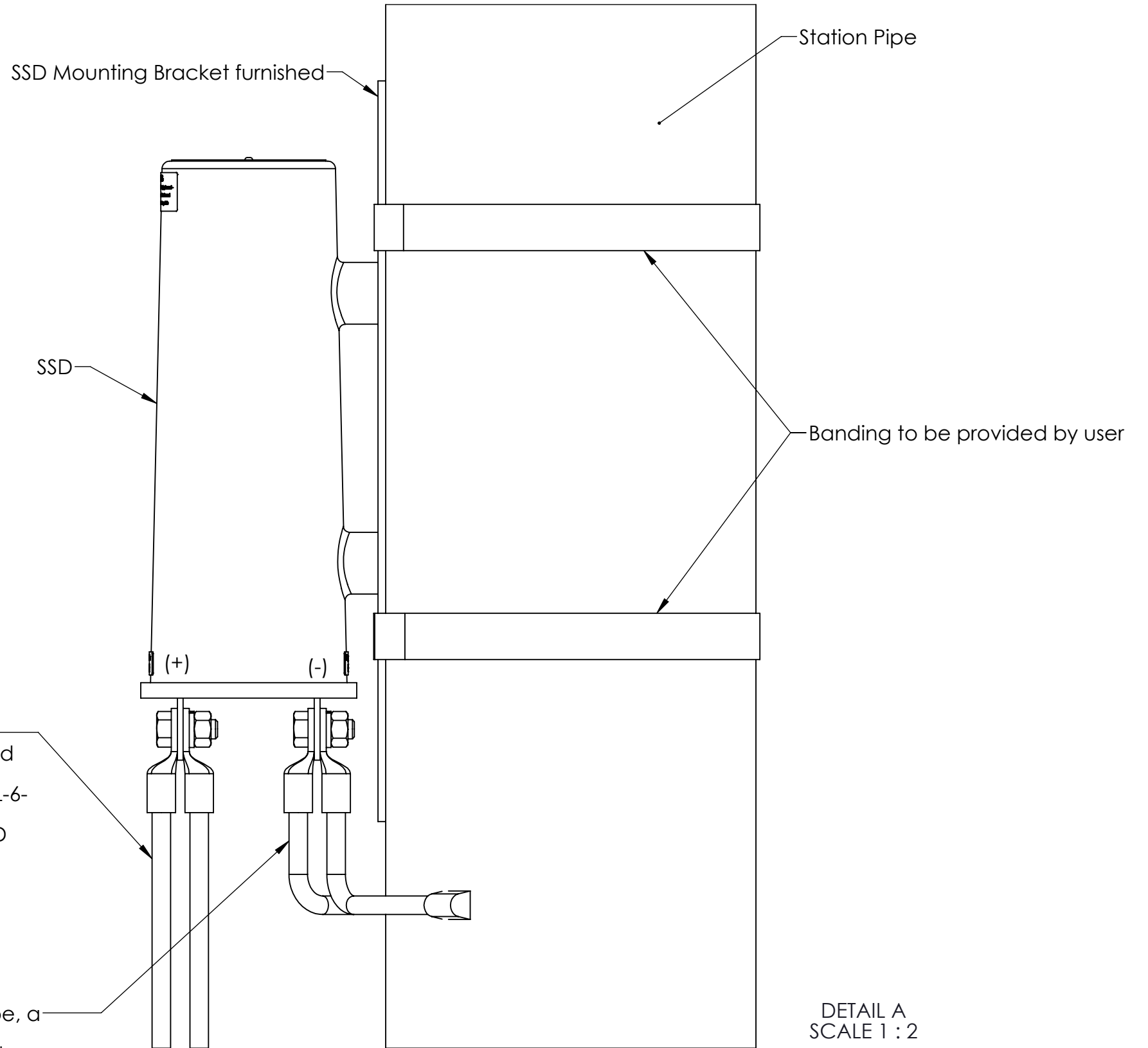
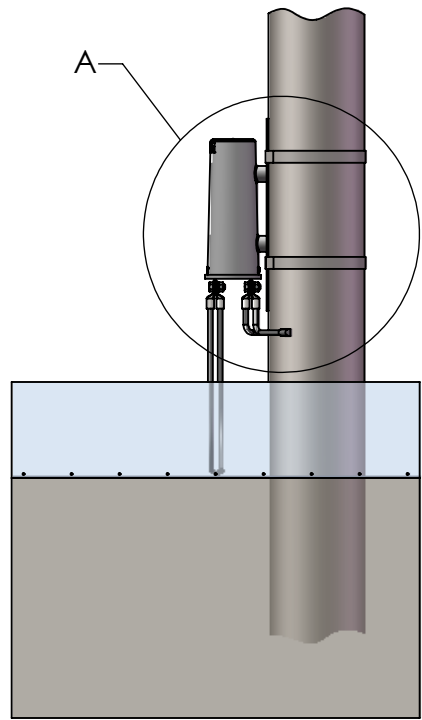

#6 AWG conductors with terminals attached on one end plus nuts, bolts, and washers available from Dairyland. Specify #MTL-6-12 for 12" (300mm) or MTL-6-36 for 36" (900mm) for a set of two conductors. Two conductors to each SSD terminal are recommended. Other conductor ends are unfinished.

For conductor connections to a steel pipe, a thermit weld is recommended. Make conductor lengths between SSD bus and pipe as short as possible to minimize inductive voltage drop due to lightning and switching transients.

DETAIL A
SCALE 1 : 2

ANSI Y14.5M 1994 APPLIES
UNLESS NOTED
UNITS: INCHES
3-PLACE: ±.005
2-PLACE: ±.015
1-PLACE / FRAC: ±.03
ANGULAR: ±1



**DAIRYLAND
ELECTRICAL
INDUSTRIES, INC.**
P.O. BOX 187
STOUGHTON,
WI 53589
608-877-9900
DAIRYLAND.COM

DESCRIPTION		Decoupling of Gradient Control Mat: Banding SSD to Pipe			
DOCUMENT #	REV	DATE DRAWN	DWG SIZE	DATE APPROVAL	
100103	A	2017-02-20	B	2017-02-24	
SCALE 1:12	DRAWN: JPW	SHEET: 2 OF 3	DWG APPROVAL: JWV		

Note: This drawing to be used in combination with Gradient Control Mat installation instructions

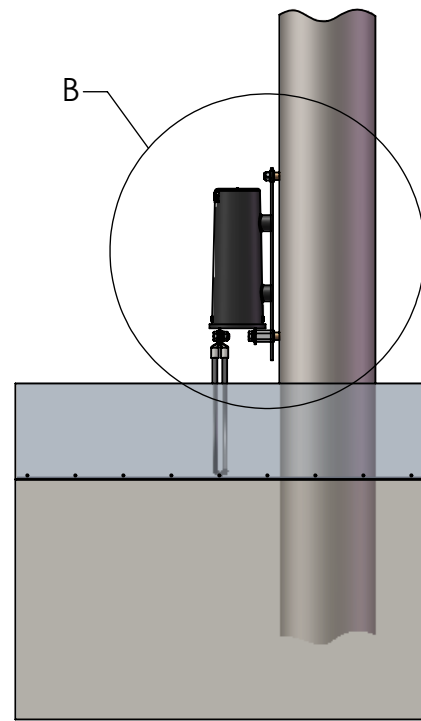

This installation method requires pin brazing equipment and M8 -1.25 threaded studs furnished by others. Install studs to spacing shown +/- 0.10" or +/- 2.5mm. Contact Dairyland for further information

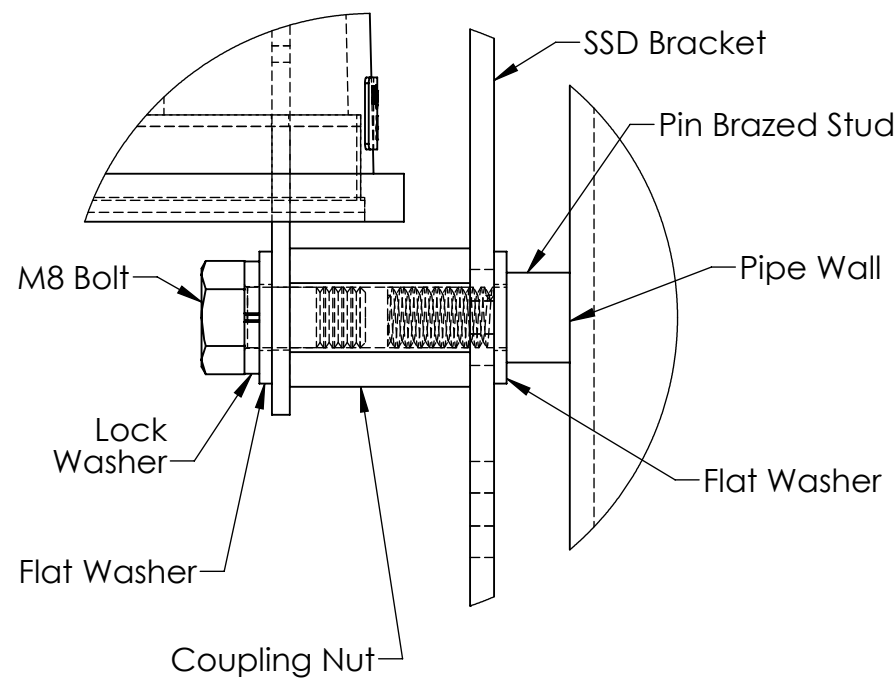

DETAIL C
SCALE 1 : 1

To connect NEGATIVE terminal to pipe via the pin brazed stud, specify #HCN-M8 to obtain the Hex Coupling Nut plus M8 Bolt and washers required. Use with SSD model: SSD-2/2-1.2-75

Hex coupling nut is first tightened onto pin brazed stud, then M8 bolt (with washers) is tightened into the coupling nut.

#6 Awg conductors with terminals attached on one end plus nuts, bolts, and washers available from Dairyland. Two conductors are recommended to the SSD terminal. Other conductor ends are unfinished.

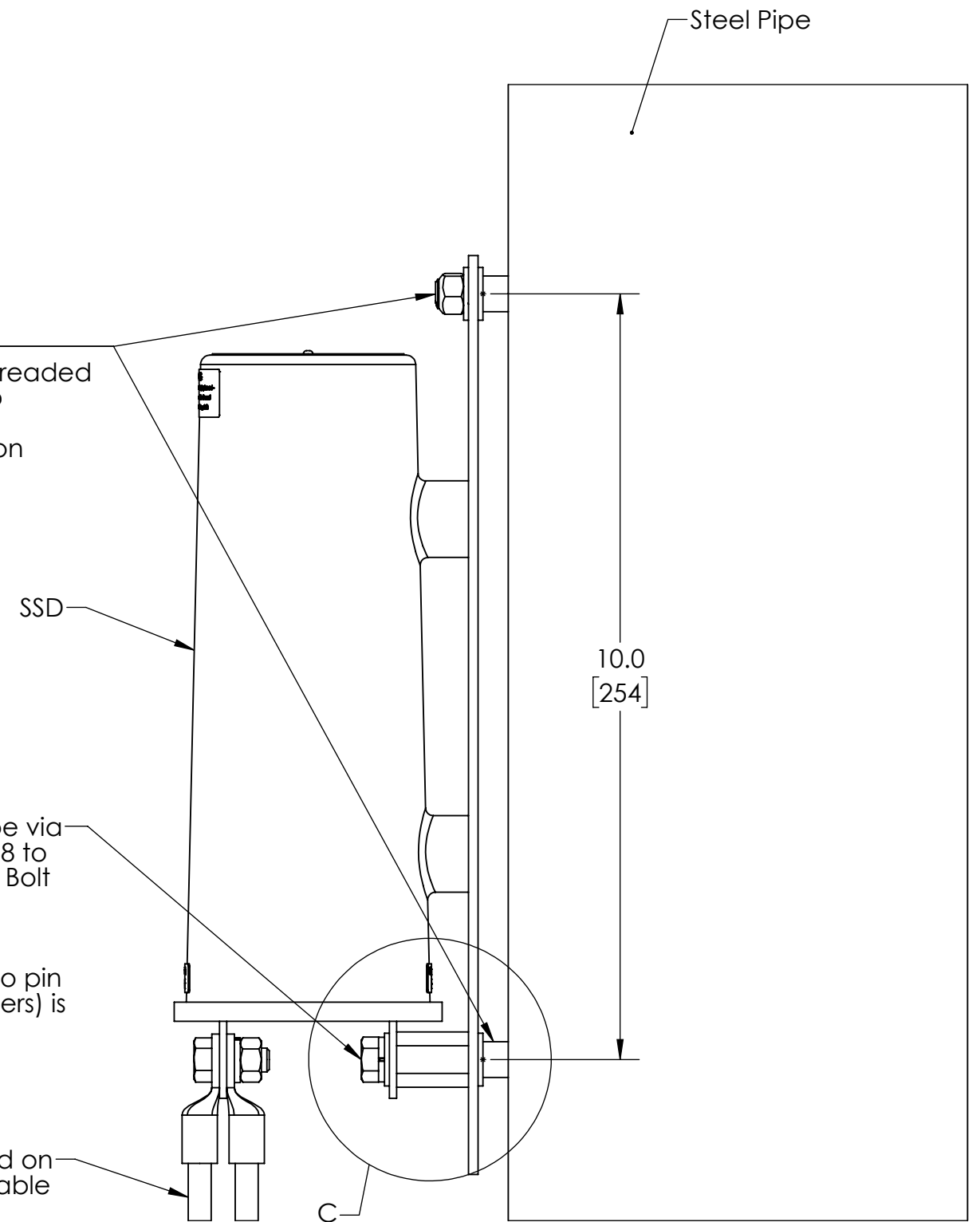

DETAIL B
SCALE 1 : 2

ANSI Y14.5M 1994 APPLIES
UNLESS NOTED
UNITS: INCHES
3-PLACE: ±.005
2-PLACE: ±.015
1-PLACE / FRAC: ±.03
ANGULAR: ±1



**DAIRYLAND
ELECTRICAL
INDUSTRIES, INC.**
P.O. BOX 187
STOUGHTON,
WI 53589
608-877-9900
DAIRYLAND.COM

DESCRIPTION		Decoupling of Gradient Control Mat: Pin Brazed Stud Connection to Pipe			
DOCUMENT #	REV	DATE DRAWN	DWG SIZE	DATE APPROVAL	
100103	A	2017-02-20	B	2017-02-24	
SCALE 1:12	DRAWN: JPW	SHEET: 3 OF 3	DWG APPROVAL: JWV		



GUIDELINES FOR CATHODIC PROTECTION OF GALVANIZED STEEL GRADIENT CONTROL MATS

1.0 APPLICABILITY

- 1.1 These guidelines apply to cathodic protection of galvanized steel gradient control mats installed at pipeline appurtenances to reduce electrical step and touch potentials in areas where persons could come into contact with a pipeline appurtenance subject to hazardous potentials.
- 1.2 These guidelines do not apply when the gradient mat is connected to other grounding systems, either directly or indirectly through the pipeline appurtenance. These applications require consultation with a cathodic protection specialist.
- 1.3 If the pipeline is not cathodically protected, the galvanized steel mat should be connected only via a decoupling device, or provision should be made to protect both the pipe and the mat in consultation with a cathodic protection specialist.

2.0 ANODES

- 2.1 The magnesium anodes used to protect the mats should be either high potential packaged magnesium anodes (Alloy M1C) or H1-Alloy (Standard) packaged magnesium anodes, as indicated in Table 1.

Table 1. Magnesium Anode Data

Anode Type	Alloy (ASTM B843-93)	Weight (Lbs.)	Standard Package Dimensions
17S4	H-1 Alloy Grade A	17	6.5" x 19"
17D4	M1C (High Potential)	17	6.5" x 19"
32S5	H-1 Alloy Grade A	32	8" x 30"
32D5	M1C (High Potential)	32	8" x 30"

- 2.2 The packaged anodes should be provided with 10 ft. of AWG 6/7 RWU 90 cable. The backfill should be a mix of 75% hydrated gypsum, 15% bentonite, and 5% sodium sulphate.



CP of Galvanized Steel Gradient Control Mats

2.3 The type and quantity of the packaged anodes should be in accordance with Table 2. Contact DEI if the size of the mat exceeds 16' x 16'.

Table 2. Required Type and Number of Magnesium Anodes

Mat Size	Soil Resistivity (Ω -cm) ^[1]	Anode Type	Required No. of Anodes	Calculated Anode Service Life		Layout
				Decoupled GCM	Directly Connected GCM ^[2]	
4' x 8'	Low (1000 to 2000)	32S5	1	>20 years	>18 years	Figure 3
	Moderate (Over 2000)	17S4	1	>20 years	>20 years	Figure 3
8' x 8'	Low (1000 to 2000)	32S5	1	>20 years	>17 years	Figure 1
	Moderate (Over 2000)	17D4	1	>20 years	>20 years	Figure 1
8' x 16'	Low (1000 to 2000)	17S4	2	>20 years	>19 years	Figure 4
	Moderate (Over 2000)	32D5	1	>20 years	>20 years	Figure 3
12' x 16'	Low (1000 to 2000)	32S5	2	>20 years	>20 years	Figure 4
	Moderate (Over 2000)	32D5	2	>20 years	>20 years	Figure 4
16' x 16'	Low (1000 to 2000)	32S5	2	>20 years	>19 years	Figure 2
	Moderate (Over 2000)	32D5	2	>20 years	>20 years	Figure 2

^[1] The cathodic protection system was designed to provide an anode life in excess of 20 years in soil resistivities as low as 1000 Ω -cm and to provide the required protection current at soil resistivities up to 15,000 Ω -cm. Soils with resistivities higher than 15,000 Ω -cm are not considered corrosive.

^[2] If the gradient control mat is directly connected to a pipe appurtenance, then the polarized potential of the protected structure is expected to drop from -1100mV_{CSE} to -850 mV_{CSE} and the service life of the anode would be reduced by 28% for high potential anodes and by 36% for H1-Alloy anodes.



3.0 ANODE INSTALLATION

- 3.1 The anodes should be installed horizontally approximately 3 ft. below the mat, as indicated in Figures 1 to 4.
- 3.2 The anode wire should be run to a close mat wire. The radius of bends should be at least 8".
- 3.3 The #6 AWG anode wire connections to the 0.135" diameter galvanized steel wire of the gradient control mat and the mechanical/electrical bonding of the galvanized steel wires in adjacent gradient control mats should be done by thermit welding. Custom molds and the weld metal for each case are available from DEI (Dairyland Electrical Industries, Inc.) All thermit welded connections should be sealed with two or more layers of Denso LT tape.

3.0 ANODE INSTALLATION CONT'D

3.3 Cont'd

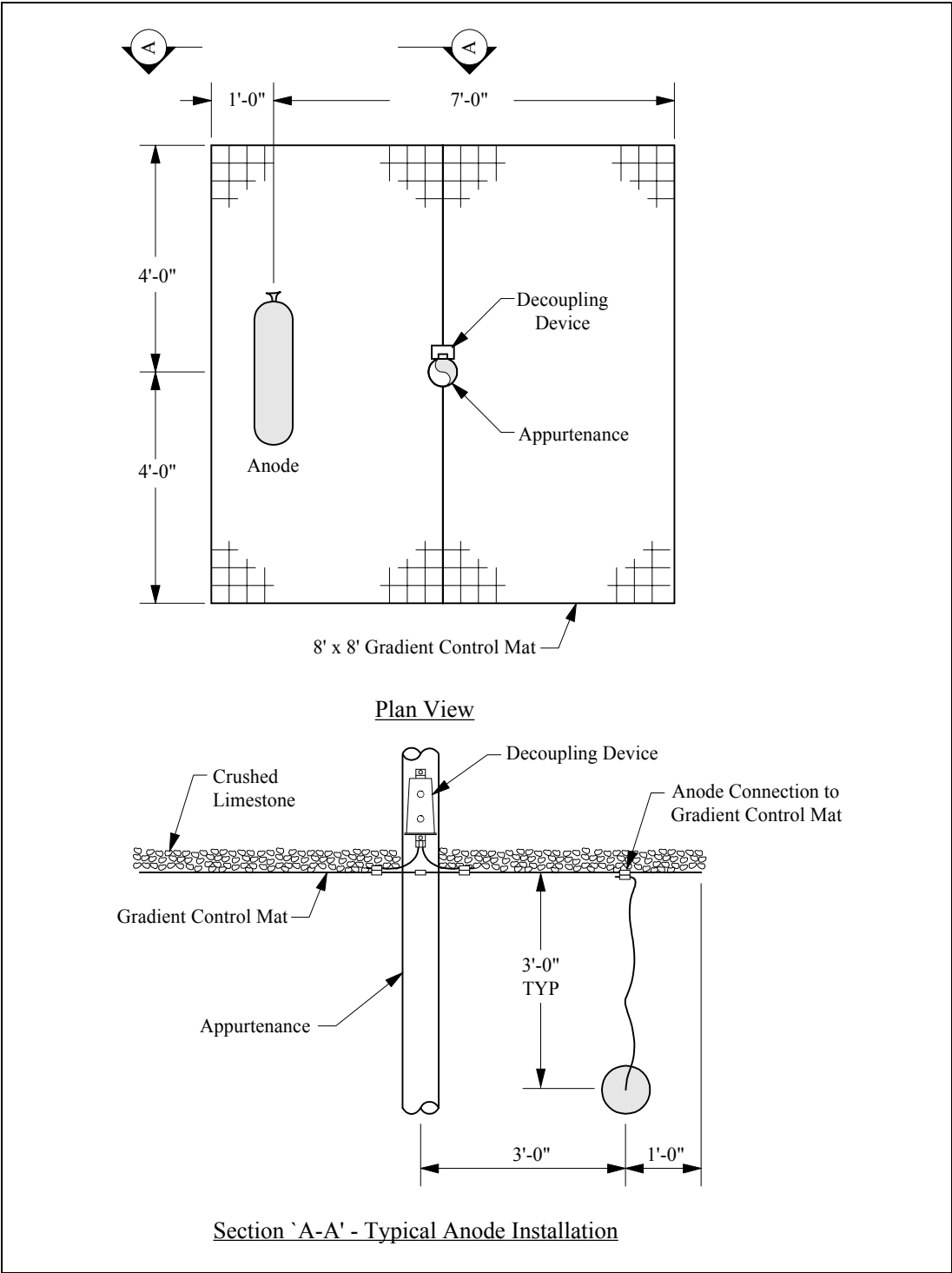

FIGURE 1 • Square Gradient Control Mat with One Anode

3.0 ANODE INSTALLATION CONT'D

3.3 Cont'd

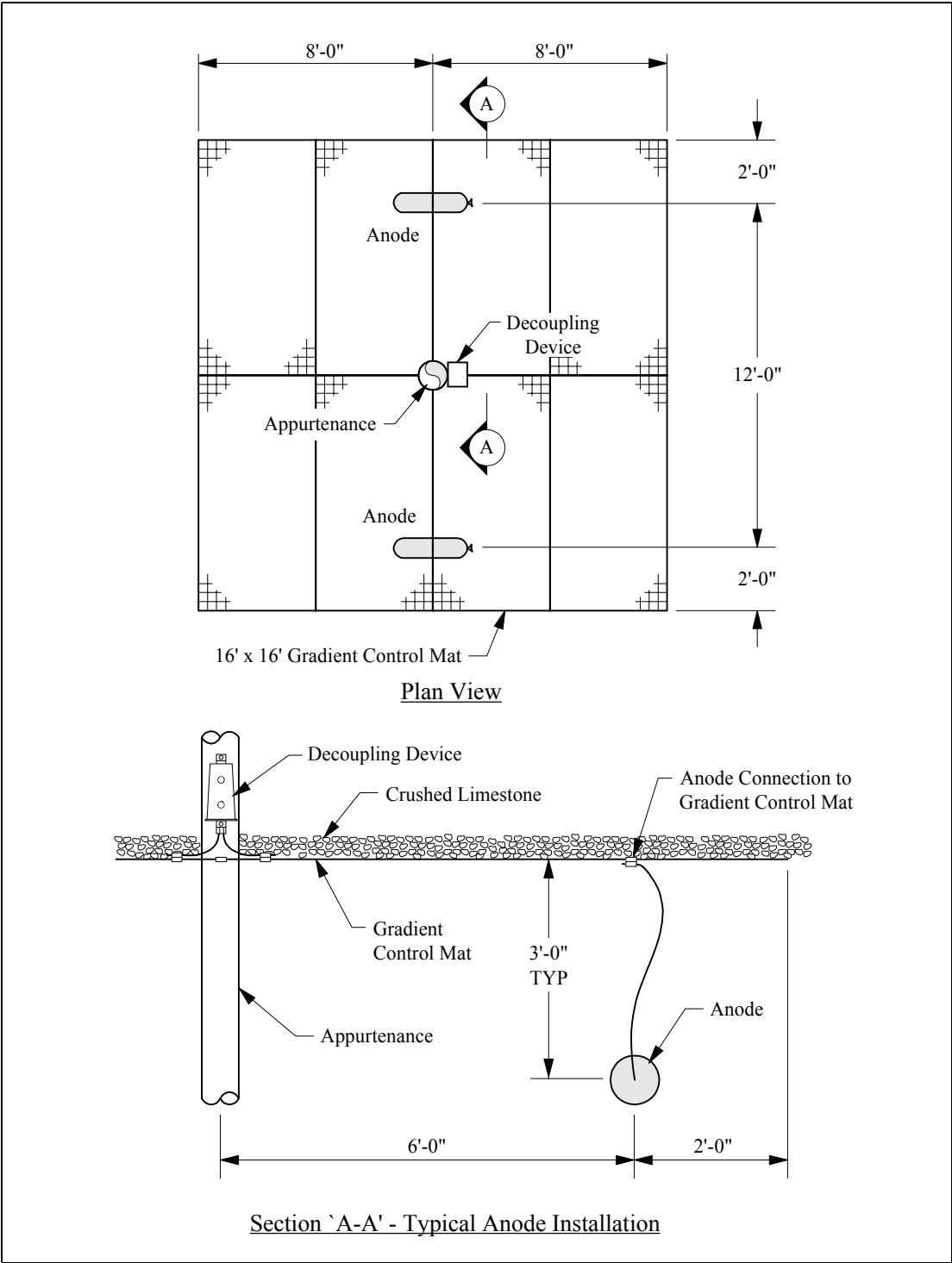

FIGURE 2 • Square Gradient Control Mat with Two Anodes

3.0 ANODE INSTALLATION CONT'D

3.3 Cont'd

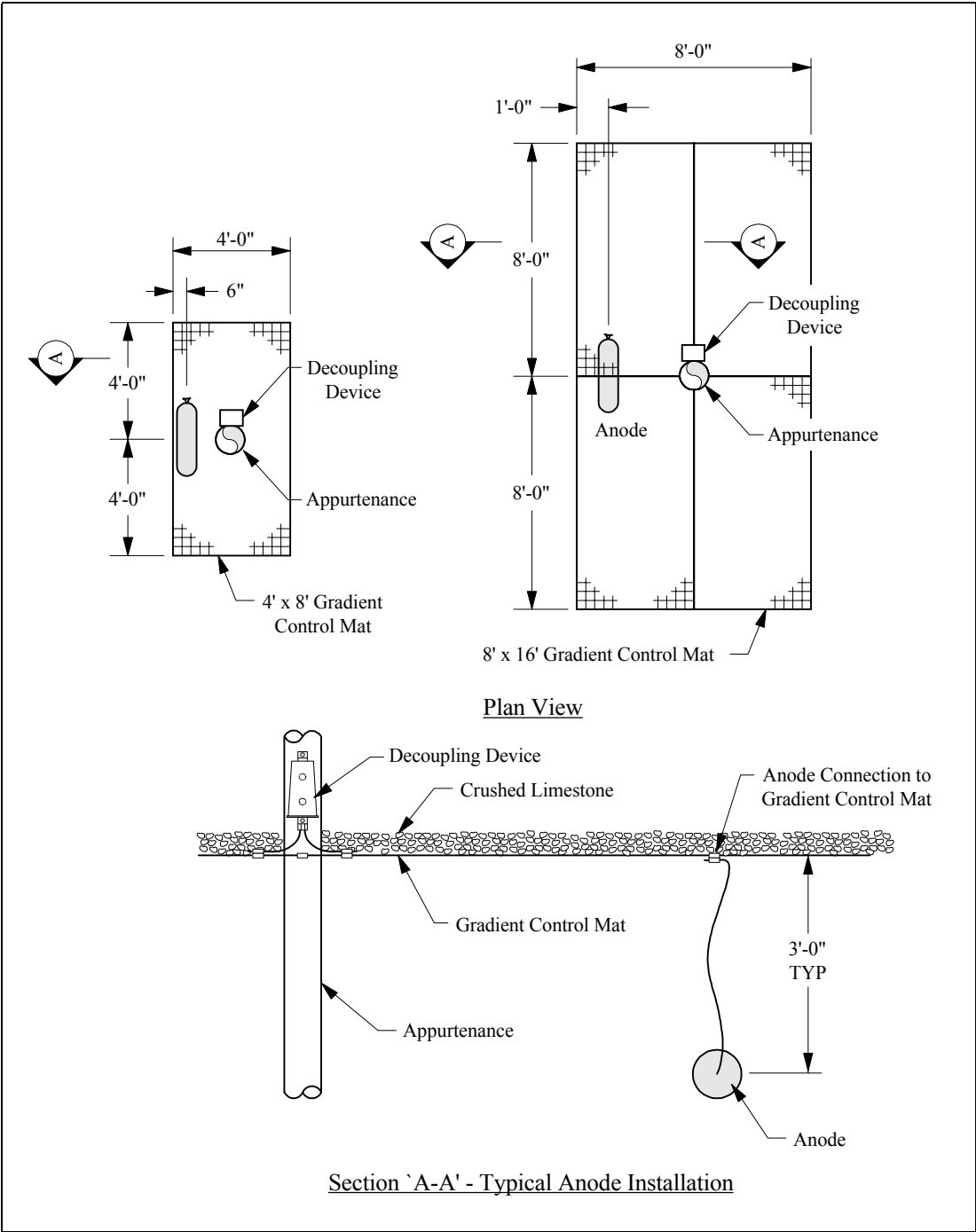

FIGURE 3 • Rectangular Gradient Control Mat with One Anode

3.0 ANODE INSTALLATION CONT'D

3.3 Cont'd

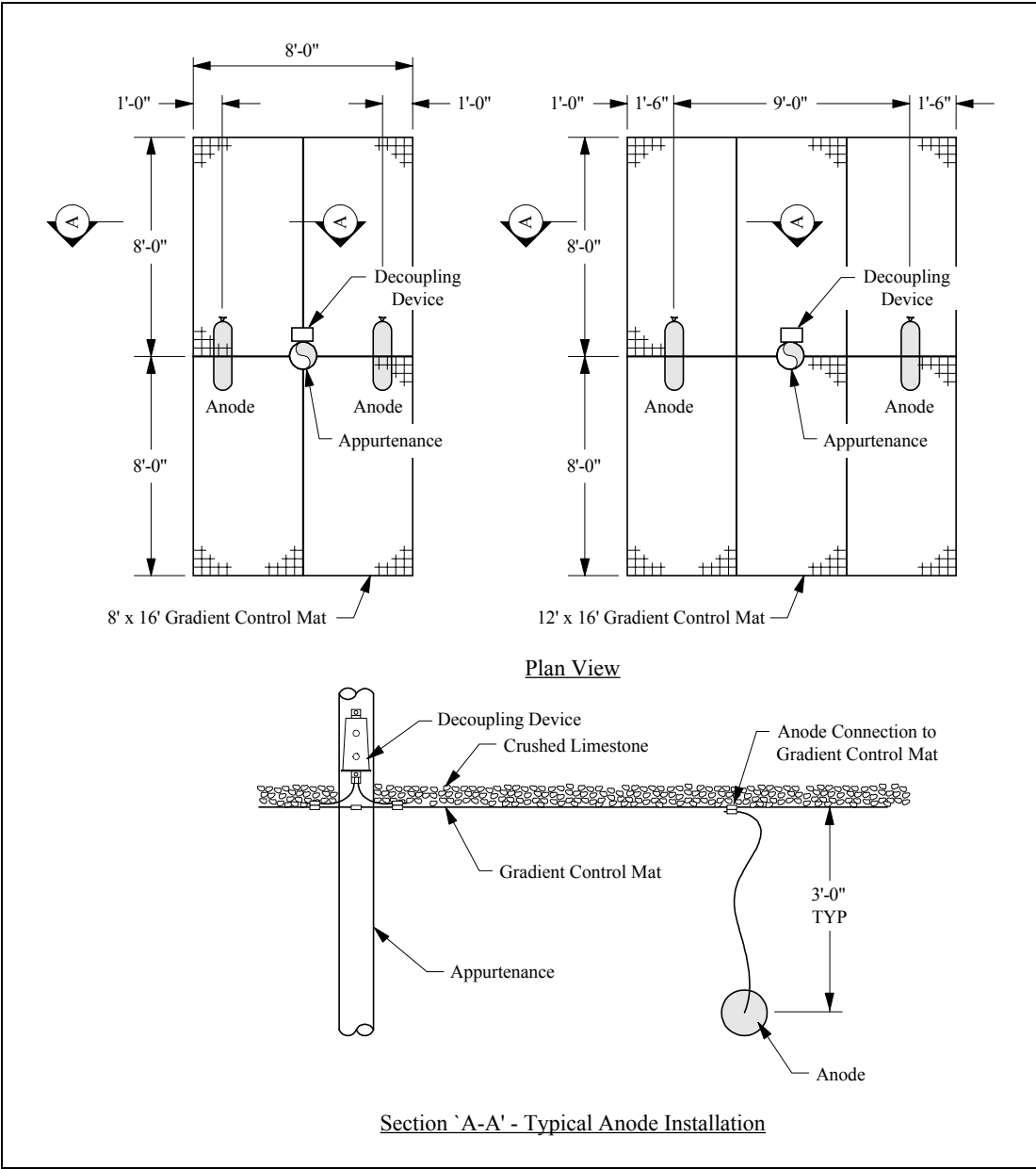

FIGURE 4 • Rectangular Gradient Control Mat with Two Anodes



4.0 ADDITIONAL RECOMMENDATIONS

- 4.1 It is recommended to use crushed limestone as the high resistivity layer to be installed on top of the safety mat, in order to minimize the attack of acid rain on the galvanized steel.