

# SIEMENS

## Weighing systems

### Load cells SIWAREX WL200

#### Operating Instructions

<u>Introduction</u>	<b>1</b>
<u>Notes on handling the product</u>	<b>2</b>
<u>Description</u>	<b>3</b>
<u>Application planning</u>	<b>4</b>
<u>Mounting and connecting</u>	<b>5</b>
<u>Adjustment and initial commissioning</u>	<b>6</b>
<u>Servicing and maintenance</u>	<b>7</b>
<u>Error messages and troubleshooting</u>	<b>8</b>
<u>Technical data</u>	<b>9</b>
<u>Dimension drawings</u>	<b>10</b>
<u>Ordering data</u>	<b>11</b>
<u>Appendix</u>	<b>A</b>

## Legal information

### Warning notice system

This manual contains notices you have to observe in order to ensure your personal safety, as well as to prevent damage to property. The notices referring to your personal safety are highlighted in the manual by a safety alert symbol, notices referring only to property damage have no safety alert symbol. These notices shown below are graded according to the degree of danger.

 <b>DANGER</b>
indicates that death or severe personal injury <b>will</b> result if proper precautions are not taken.

 <b>WARNING</b>
indicates that death or severe personal injury <b>may</b> result if proper precautions are not taken.

 <b>CAUTION</b>
indicates that minor personal injury can result if proper precautions are not taken.

<b>NOTICE</b>
indicates that property damage can result if proper precautions are not taken.

If more than one degree of danger is present, the warning notice representing the highest degree of danger will be used. A notice warning of injury to persons with a safety alert symbol may also include a warning relating to property damage.

### Qualified Personnel

The product/system described in this documentation may be operated only by **personnel qualified** for the specific task in accordance with the relevant documentation, in particular its warning notices and safety instructions.

Qualified personnel are those who, based on their training and experience, are capable of identifying risks and avoiding potential hazards when working with these products/systems.

### Proper use of Siemens products

Note the following:

 <b>WARNING</b>
Siemens products may only be used for the applications described in the catalog and in the relevant technical documentation. If products and components from other manufacturers are used, these must be recommended or approved by Siemens. Proper transport, storage, installation, assembly, commissioning, operation and maintenance are required to ensure that the products operate safely and without any problems. The permissible ambient conditions must be complied with. The information in the relevant documentation must be observed.

### Trademarks

All names identified by ® are registered trademarks of Siemens AG. The remaining trademarks in this publication may be trademarks whose use by third parties for their own purposes could violate the rights of the owner.

### Disclaimer of Liability

We have reviewed the contents of this publication to ensure consistency with the hardware and software described. Since variance cannot be precluded entirely, we cannot guarantee full consistency. However, the information in this publication is reviewed regularly and any necessary corrections are included in subsequent editions.

# Table of contents

<b>1</b>	<b>Introduction</b> .....	<b>7</b>
1.1	History .....	7
1.2	Environmental protection .....	7
<b>2</b>	<b>Notes on handling the product</b> .....	<b>9</b>
<b>3</b>	<b>Description</b> .....	<b>15</b>
3.1	Range of application .....	15
3.2	Design and principle of operation .....	15
3.3	Product overview.....	17
3.4	Rating plate and ATEX plate.....	20
<b>4</b>	<b>Application planning</b> .....	<b>23</b>
4.1	Planning .....	23
4.2	Transverse forces and overload protection .....	26
4.3	Lengthening and shortening the connecting cable .....	28
<b>5</b>	<b>Mounting and connecting</b> .....	<b>31</b>
5.1	Safety information/instructions.....	31
5.1.1	General safety instructions .....	31
5.1.2	Safety instructions when connecting in hazardous areas.....	33
5.2	Installation .....	36
5.3	Connecting principle .....	37
5.4	Connecting up.....	40
5.5	Dismantling .....	44
<b>6</b>	<b>Adjustment and initial commissioning</b> .....	<b>45</b>
6.1	Height compensation .....	46
6.1.1	When is height compensation necessary? .....	46
6.1.2	Procedure for height compensation .....	46
6.2	Initial commissioning.....	47
6.3	Corner load adjustment.....	47
6.3.1	When is corner load adjustment necessary? .....	47
6.3.2	General procedure for corner load adjustment .....	47
6.3.3	Example for corner load adjustment .....	48
<b>7</b>	<b>Servicing and maintenance</b> .....	<b>51</b>

<b>8</b>	<b>Error messages and troubleshooting</b> .....	<b>53</b>
8.1	Repair.....	53
8.2	Error messages.....	53
8.3	Checking the mechanical and electrical configuration.....	53
8.4	Checking the load cells.....	54
8.5	Measures in the event of overloaded load cells.....	56
<b>9</b>	<b>Technical data</b> .....	<b>57</b>
9.1	Functional data.....	57
9.1.1	SIWAREX WL260 SP-S AA.....	57
9.1.2	SIWAREX WL260 SP-S AB.....	58
9.1.3	SIWAREX WL260 SP-S SA.....	59
9.1.4	SIWAREX WL260 SP-S SB.....	60
9.1.5	SIWAREX WL260 SP-S SC.....	61
9.1.6	SIWAREX WL250 ST-S SA.....	62
9.1.7	SIWAREX WL230 BB-S SA.....	63
9.1.8	SIWAREX WL230 SB-S SA.....	64
9.1.9	SIWAREX WL270 CP-S SA.....	65
9.1.10	SIWAREX WL270 CP-S SB.....	66
9.1.11	SIWAREX WL270 CP-S SC.....	67
9.1.12	SIWAREX WL270 K-S CA.....	68
9.1.13	SIWAREX WL280 RN-S SA.....	70
9.2	Approval to OIML R60.....	72
9.3	Electromagnetic compatibility.....	72
9.4	Certificates and approvals for explosion protection.....	73
<b>10</b>	<b>Dimension drawings</b> .....	<b>75</b>
10.1	SIWAREX WL260 SP-S AA.....	76
10.2	SIWAREX WL260 SP-S AB.....	77
10.3	SIWAREX WL260 SP-S SA.....	78
10.4	SIWAREX WL260 SP-S SB.....	79
10.5	SIWAREX WL260 SP-S SC.....	80
10.6	SIWAREX WL250 ST-S SA.....	81
10.7	SIWAREX WL230 BB-S SA.....	82
10.8	SIWAREX WL230 SB-S SA.....	83
10.9	SIWAREX WL270 CP-S SA.....	84
10.10	SIWAREX WL270 CP-S SB.....	85
10.11	SIWAREX WL270 CP-S SC.....	86
10.12	SIWAREX WL270 K-S CA.....	87
10.13	SIWAREX WL280 RN-S SA.....	89

<b>11</b>	<b>Ordering data.....</b>	<b>95</b>
11.1	Load cells.....	95
11.2	Accessories.....	102
<b>A</b>	<b>Appendix.....</b>	<b>103</b>
A.1	Technical support.....	103
	<b>Index.....</b>	<b>105</b>



## Introduction

### 1.1 History

The following versions of this documentation have been released to date. The changes apply to the previous version:

<b>Edition</b>	<b>Comment / change</b>
10/2008	Initial release
04/2009	Addition to SP-S SA 30 t load cell. Designation updated: WL200 instead of WL 200. Corrections made mainly to the specifications. Additions to explosion protection and ATEX approval
07/2010	Addition to WL280 RN-S SA 10 t; 13 t; 28 t and 60 t load cells.
09/2010	Addition to WL280 RN-S SA 60 kg to 5 t load cells Addition to WL270 K-S CA load cells
02/2013	WL270 K-S CA load cells with additional versions (high temperature, double bridge) and extended operating range up to 500 t. WL260 SP-S SB load cells and WL260 SP-S SC load cells.
09/2013	Expansion of the load cells WL270 K and WL280 RN for hazardous areas
11/2013	Dimensions of load cells WL250 ST-S SA changed.

### 1.2 Environmental protection

#### Environmental protection

Devices described in this programming manual can be recycled owing to the low content of noxious substances in their version. Please contact a certified waste disposal company for eco-friendly recycling and to dispose of your old devices.





## Notes on handling the product

This device left the factory in good working condition. In order to maintain this status and to ensure safe operation of the device, observe these instructions and all the specifications relevant to safety.

Observe the information and symbols on the device. Do not remove any information or symbols from the device. Always keep the information and symbols in a completely legible state.

Symbol	Explanation
	Consult operating instructions

Observe the test certification, provisions and laws applicable in your country during connection, assembly and operation. These include, for example:

- National Electrical Code (NEC - NFPA 70) (USA)
- Canadian Electrical Code (CEC) (Canada)

Further provisions for hazardous area applications are for example:

- IEC 60079-14 (international)
- EN 60079-14 (EC)

The CE mark on the device is a sign of conformity with the following European directives:

Electromagnetic Compatibility EMC 2004/108/EC	Directive of the European Parliament and of the Council on the approximation of the laws of the Member States relating to electromagnetic compatibility and repealing Directive 89/336/EEC.
Atmosphère explosible ATEX 94/9/EC	Directive of the European Parliament and the Council on the approximation of the laws of the Member States concerning equipment and protective systems intended for use in potentially explosive atmospheres.

The standards applied can be found in the EC declaration of conformity for the device.

 <b>WARNING</b>
<b>Improper device modifications</b> <p>Danger to personnel, system and environment can result from modifications to the device, particularly in hazardous areas.</p> <ul style="list-style-type: none"><li>• Only carry out modifications that are described in the instructions for the device. Failure to observe this requirement cancels the manufacturer's warranty and the product approvals.</li></ul>

## Proper use

Proper use means that this product must only be used within the limits of the technical specifications and intended purposes of these operating instructions.

If this device is used properly in compliance with the safety notices, this device will not present any danger.

This device can only function correctly and safely if it is transported, stored, set up and mounted correctly.

Correct operation of the device must be ensured by complying with the technical specifications.

Improper handling can result in death, personal injury or property damage.

## Notes on responsibility for defects

We expressly point out that the product quality is exclusively and conclusively described in the sales contract. The content of this product documentation is neither part of a previous or existing agreement, promise or legal relationship, nor is it intended to modify these. All obligations on the part of Siemens AG are contained in the respective sales contract, which also contains the complete and solely applicable liability provisions. The provisions defined in the sales contract for the responsibility for defects are neither extended nor limited by the remarks in this document.

## Delivery information

The current scope of delivery is listed on the shipping documents enclosed with the delivery in accordance with the valid sales contract.

When opening the packaging, please observe the relevant information. Check the delivery for completeness and undamaged condition. In particular, the order number on the rating plate must be compared to the ordering data.

Before you start work, please read these operating instructions. They contain important information and data whose observation ensures the general safety and functionality of this device. The manual will help you to handle this product more easily and efficiently, allowing you to achieve reliable results.

## Qualified personnel

In the context of this documentation, qualified personnel are people who are familiar with the installation, mounting, commissioning, and operation of the product.

These people must have the following qualifications:

- They must be trained, instructed and authorized to operate and maintain devices and systems in accordance with their place of work and in compliance with the safety engineering standards for
  - Electrical circuits
  - High pressures
  - Corrosive and hazardous media
- They must be trained, instructed and authorized to maintain and use appropriate safety equipment according to the standards for safety engineering.

### Qualified personnel for hazardous area applications

Persons who install, connect, commission, operate, and service the device in a hazardous area must have the following specific qualifications:

- They are authorized, trained or instructed in operating and maintaining devices and systems according to the safety regulations for electrical circuits, high pressures, aggressive, and hazardous media.
- They are authorized, trained, or instructed in carrying out work on electrical circuits for hazardous systems.
- They are trained or instructed in maintenance and use of appropriate safety equipment according to the pertinent safety regulations.

## Important notes on cleaning

<b>NOTICE</b>
<b>Damage to load cells, measurement errors</b> Dirt must not be allowed to accumulate in the vicinity of a load cell. Do not subject cable glands and seals to the jet from a pressure washer.

## Protection against explosion

 <b>WARNING</b>
<p><b>Risk of explosion</b></p> <p>For applications in hazardous areas please observe the following information as otherwise there is a risk of explosion.</p> <p>If used in hazardous areas the device requires an ATEX approval with test certification. The information in these documents must be observed when using the load cells in hazardous areas.</p> <p>Keep to the national regulations and laws applicable in your country when making electrical connections in hazardous areas. In Germany, these include, for example:</p> <ul style="list-style-type: none"><li>• Operational safety regulation</li><li>• The directive for "Installation of electrical systems in hazardous areas", DIN EN 60079-14 (previously VDE 0165,T1)</li><li>• The EC type examination certificate</li></ul> <p>If auxiliary power is required, check that it corresponds with that on the rating plate and with the test certification valid for your country.</p>

 <b>WARNING</b>
<p><b>Unsuitable device for the hazardous area</b></p> <p>Danger of explosion.</p> <ul style="list-style-type: none"><li>• Only use equipment that is approved for use in the intended hazardous area and labelled accordingly.</li></ul>

 <b>WARNING</b>
<p><b>Loss of safety of device with type of protection "Intrinsic safety Ex i"</b></p> <p>If the device has already been operated in non-intrinsically safe circuits or the electrical specifications have not been observed, the safety of the device is no longer ensured for use in hazardous areas. There is a danger of explosion.</p> <ul style="list-style-type: none"><li>• Connect the device with type of protection "Intrinsic safety" solely to an intrinsically safe circuit.</li><li>• Observe the specifications for the electrical data on the certificate and in Chapter "Technical data (Page 57)".</li></ul>

## Electrostatic Sensitive Devices - ESD

<b>NOTICE</b>
<b>Damage to load cells, measurement errors</b>
Dirt must not be allowed to accumulate in the vicinity of a load cell. Do not subject cable glands and seals to the jet from a pressure washer.

<b>NOTICE</b>
<b>Damage to electrostatic sensitive devices</b>
This device contains electrostatic sensitive devices. Modules susceptible to electrical discharge can be destroyed by voltages that fall far below the limits of human perception. Voltages of this kind occur as soon as a component or an assembly is touched by a person who is not grounded against static electricity. The damage to a module as a result of overvoltage cannot usually be detected immediately. It may only become apparent after a long period of operation.

## Trademarks

SIWAREX ® is a registered trademark of Siemens AG.

All other names appearing in these instructions may be trademarks; use of such names by third parties for their own purposes may infringe upon owners rights.



## Description

### 3.1 Range of application

SIWAREX load cells are used for measuring forces and weights statically and dynamically. You can use SIWAREX load cells for almost all applications in industrial weighing technology. Examples include:

- Container weighers, hopper scales or platform scales,
- Roller table, conveyor or crane scales,
- Plants for bottling/packing, dosing and mixing,
- for checking levels and completeness,
- Equipment for monitoring pressing or stretching processes,
- Dynamic scales

All applications can be implemented in equipment requiring official calibration or in areas subject to explosion hazards.

### 3.2 Design and principle of operation

#### Design

SIWAREX load cells are based on strain gauges. Strain-gauge load cells are transducers which convert mechanical forces into electrical signals. The principle of operation is the same regardless of variations in design.

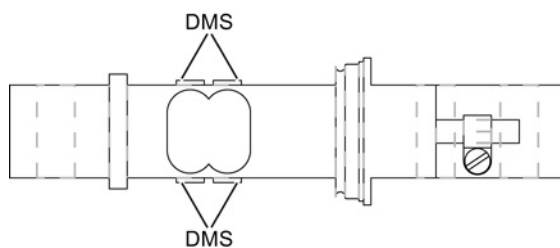

Figure 3-1 Design, based on the example of an unloaded bending beam load cell

### Principle of operation

The basic component in each case is a special type of spring body. The application of force elastically deforms the spring body. The ohmic resistance of the strain gauges changes as a result.

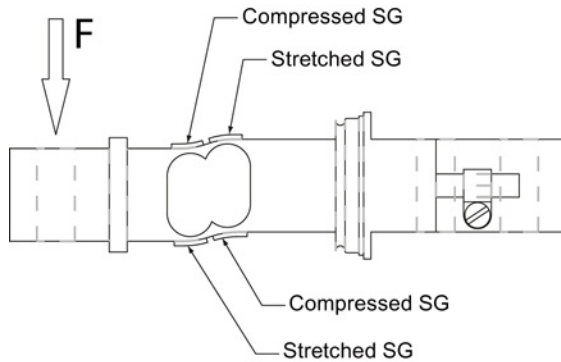

Figure 3-2 Principle of operation, based on the example of a loaded bending beam load cell

For each load cell, at least four strain gauges are connected together as a complete Wheatstone bridge. The stretched or compressed strain gauges are connected in such a manner that the positive or negative resistance changes are summed to produce an overall imbalance of the bridge.

The supply voltage is applied across one diagonal of the bridge and, in the case of the six-wire connection method, also the sensor voltage SENSE. The measured voltage is tapped across the other diagonal.

For a constant supply voltage EXC, therefore, the measured voltage SIG changes proportionally to the introduced load. In practice, load cells contain additional resistors for temperature compensation and for zero-signal and characteristic-value compensation. Depending on their type and the requirements, these resistors can be arranged at the input or output of the load cell.

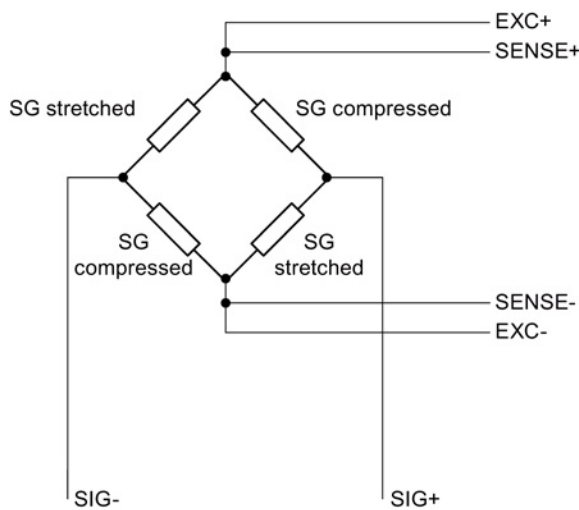

Figure 3-3 The principle of a Wheatstone bridge















### 3.3 Product overview

Design ation	Rated load																	
	kg								t									
	2	5	10	20	50	100	200	500	1	2	5	10	20	50	100	200	350	500
SIWAREX WL260 SP-S AA	3	5	10	20	50	100												
SIWAREX WL260 SP-S AB					50; 75	100; 150	200; 300	500										
SIWAREX WL260 SP-S SA		5	10	20	50	100	200											
SIWAREX WL260 SP-S SB		6	12	30	60													
SIWAREX WL260 SP-S SC			10	20	50	100	200; 300; 400	500										
SIWAREX WL250 ST-S SA					50	100	250	500	1	2.5	5	10						
SIWAREX WL230 BB-S SA			10	20	50	100	200; 350	500										
SIWAREX WL230 SB-S SA								500	1	2; 3	5							
SIWAREX WL270 CP-S SA										2	5	10	20; 30	50				
SIWAREX WL270 CP-S SB															100			
SIWAREX WL270 K-S CA										2.8	6	13	28	60	130	280	350	500
SIWAREX WL280 RN-S SA					60	130	280	500	1	2; 3.5	5	10; 13	28	60				

Description

3.3 Product overview

Designation	Image	Construction type	Material	Platform size in mm	Accuracy class
SIWAREX WL260 SP-S AA		Single-point load cell	Aluminum	400 x 400	OIML R60 C3
SIWAREX WL260 SP-S AB		Single-point load cell	Aluminum	600 x 600	OIML R60 C3
SIWAREX WL260 SP-S SA		Single-point load cell	Stainless steel	400 x 400	OIML R60 C3
SIWAREX WL260 SP-S SB		Single-point load cell	Stainless steel	350 x 350	OIML R60 C3
SIWAREX WL260 SP-S SC		Single-point load cell	Stainless steel	400 x 400 to 800 x 800	OIML R60 C3, C4
SIWAREX WL250 ST-S SA		S type load cell	Stainless steel	-	OIML R60 C3
SIWAREX WL230 BB-S SA		Bending beam	Stainless steel	-	OIML R60 C3
SIWAREX WL230 SB-S SA		Shear beam	Stainless steel	-	OIML R60 C3
SIWAREX WL270 CP-S SA		Compression load cell	Stainless steel	-	OIML R60 C3
SIWAREX WL270 CP-S SB		Compression load cell	Stainless steel	-	OIML R60 C3
SIWAREX WL270 CP-S SC		Compression load cell	Stainless steel	-	0.1%

Designation	Image	Construction type	Material	Platform size in mm	Accuracy class
SIWAREX WL270 K-S CA	 A cylindrical stainless steel load cell with a black top cap and a side-mounted electrical connector.	Compression load cell	Stainless steel measuring element, enclosure made of painted tool steel		0.1%
SIWAREX WL280 RN-S SA	 A ring-shaped stainless steel load cell with a central circular platform and a side-mounted electrical connector.	Ring torsion load cell	Stainless steel	-	OIML R60 C3

### 3.4 Rating plate and ATEX plate

#### Layout of the rating plate

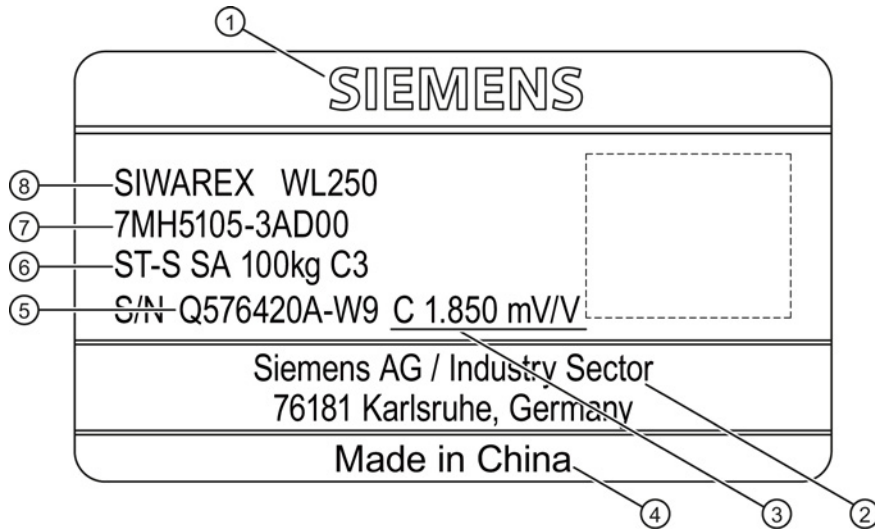

- ① Company logo
- ② Manufacturer
- ③ Rated characteristic value  $C_{Rated}$  of the load cell
- ④ Country of origin
- ⑤ Serial number
- ⑥ Identification of product
- ⑦ Order number
- ⑧ Product group designation

Figure 3-4 Rating plate (example)

### Design of the ATEX plate for SIWAREX WL230, WL250, WL260, WL270 CP

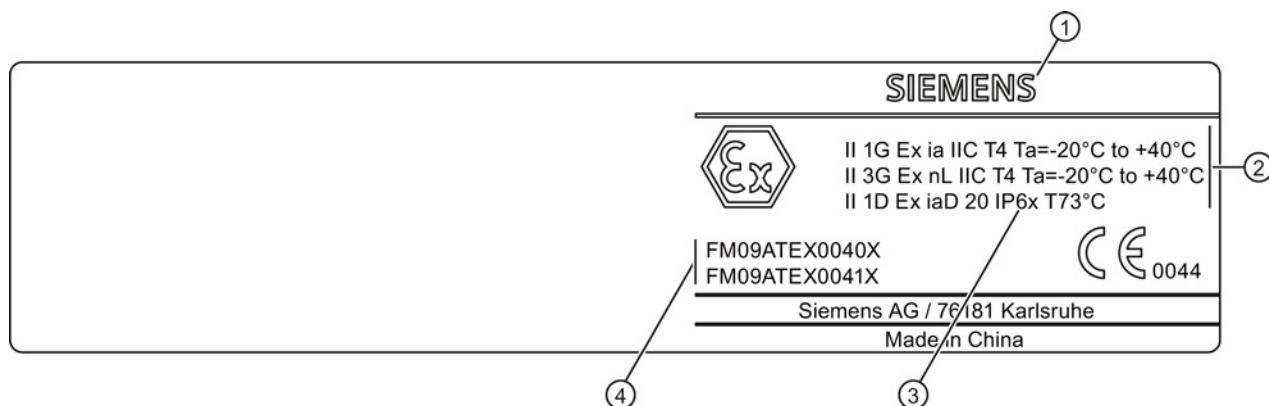

- ① Company logo
- ② Type of protection according to ATEX
- ③ Degree of protection according to EN 60 529, e.g. IP67  
The degree of protection depends on the type of load cell.
- ④ Numbers of ATEX approvals

Figure 3-5 ATEX plate (example)

### Design of the ATEX plate for SIWAREX WL270 K-S CA and WL280 RN

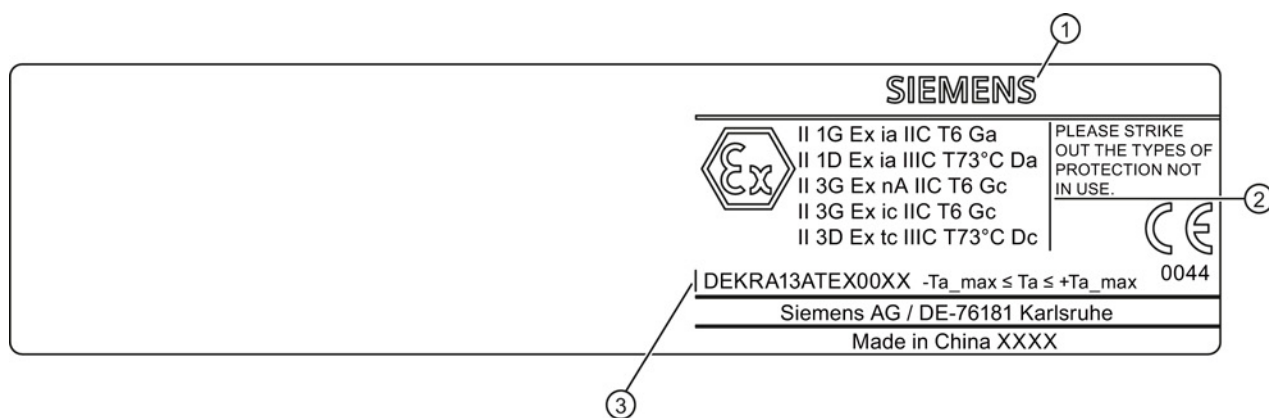

- ① Company logo
- ② Type of protection according to ATEX
- ③ Numbers of ATEX approvals

Figure 3-6 ATEX plate (example)

### **Marking of application area on ATEX plate**

The types of protection ② for which the load cell is certified are indicated on the ATEX plate.

Prior to commissioning the irrelevant types of protection on the ATEX plate have to be permanently erased. In the event of a power supply that is not intrinsically safe or if the load cell has not been supplied with intrinsically safe power the type of protection - intrinsically safe is no longer valid. See Installation (Page 36)

# Application planning

## 4.1 Planning

 <b>WARNING</b>
<b>Danger to life from falling loads</b> Load cells are not machine components which have been constructed with the normal safety factors. For this reason, appropriate protection against falling and catastrophes must be implemented in accordance with the potential risks.

### Version

SIWAREX load cells are usually manufactured from stainless steel and hermetically sealed. This provides a high degree of corrosion resistance and a high degree of protection.

Most type series are approved for use in scales requiring official calibration of Class III to DIN EN 45501 and comply with the accuracy class OIML R60 C3.

If necessary, load cells can be supplied with ATEX approval.

SIWAREX load cells are current-calibrated as standard. This means that, for example, when a platform scale is commissioned, corner load adjustment is not necessary. A load cell can therefore be replaced without recalibration of the scale.

This may not apply to load cells that are available outside the standardized delivery spectrum. For these load cell types, the relevant technical specifications apply.

### Parallel connection of load cells

In weighing systems, one or more load cells are connected to a weighing module for evaluation of the measured signal. Several load cells of a scale are connected in parallel to a junction box to supply a joint output signal.

<b>NOTICE</b>
<b>Overloading of load cells</b>
When more than one load cell is connected to a scale, if the load distribution is uneven, it cannot be established whether individual load cells are overloaded.

---

**Note**

**Measurement errors**

Load cells are only permitted to be connected in parallel when they have the same characteristic value, the same rated load and the same internal resistance.

The total resistance of load cells connected in parallel must not undershoot the minimum resistance from the technical data of the weighing module to which it should be connected.

---

The maximum number of load cells that can be connected to a weighing module depends on the total resistance of the load cells connected in parallel. This must lie within the load resistance limits specified for the weighing module.

The maximum length of the cables and the specifications for other components, e.g. Ex i interface, must also be complied with. For details, see the section Lengthening and shortening the connecting cable (Page 28)

### Environmental requirements at the mounting location

The foundations must be unyielding when the expected loads are applied. The maximum roughness permitted for the mounting surface is 1.6 µm.

The values specified in the technical data for the ambient conditions must be complied with.

---

**Note**

**Measurement errors**

The load cell must be protected against direct solar radiation. Otherwise, the permissible operating temperature may be exceeded. One-sided heating will result in less accurate measurements or even measurement errors.

---



## Grounding protection

<b>NOTICE</b>
<b>Damaging of load cells</b> Undesirable electrical currents can arise during welding or lightning. To protect the load cells against such currents, bridge the load cells using highly flexible grounding cables, see also Accessories (Page 102).

## 4.2 Transverse forces and overload protection

### Overloading of load cells

---

**Note**

**Risk of overloading**

If you connect more than one load cell to a scale, if the load distribution is uneven, it cannot be established whether individual load cells are overloaded.

---

**NOTICE**

**Damage to load cells through overloading**

In the case of load cells with small rated loads, overload protection must be implemented to protect the cells against damage.

If load cells are used beyond the maximum working load or the maximum lateral load, this can cause irreparable errors and even fracturing of the load cell.

When mounting components are fitted, the load cells must not be overloaded, e.g. by overtightening bolts.

---

**Note**

**Error message on overload**

If load cells are loaded beyond their rated load, this can result in an error message in the weighing module.

---

Overloading can occur as a result of:

- Uneven load distribution due to mounted components or cones of bulk material
- Rolling/pushing up the load on platform or roller table scales
- Forceful application of the load
- Application of the load in free fall
- Persons supporting themselves on or climbing onto the scale
- Wind against the leeward side of a silo

## **Dimensioning for overload**

When step changes in load cannot be excluded during measuring, for example, due to application of a load in free fall, you must take appropriate precautions to avoid damage to the load cell, e.g. by using elastomer bearings or load cells dimensioned for higher rated loads.

When dimensioning load cells, include a safety margin to guard against overloading:

- Use a safety margin of 20% in the case of three support points.
- If more than three support points are used in a statically indeterminate manner, the safety margin must be a minimum of 50% if it is not possible to rule out a situation in which the load rests on two diagonally opposite load cells only. Reasons for this include sinking of the foundations or incorrect mounting.
- When calculating the safety margin, include unintentional overloads or overloading caused by the course of the process, or use overload protection.

## **Lifting protection**

Overloads can also occur in the lifting direction when the force introducer is attached to the load cell.

If there is a risk of the load bearing being lifted or toppled, lifting protection may be necessary. This is required in the case of lightweight containers and tall, outdoor silos.

## **Mounting components and guide elements to counteract lateral forces, torsional and bending moments**

The load must be introduced in the measuring direction of the load cell. Torsional and bending moments, eccentric loads and lateral forces are disturbances that on the one hand falsify the measured result and on the other hand can damage the load cell if the permissible limits are exceeded. Load cells must therefore be fitted with specially adapted mounting components, e.g. with SIWAREX mounting parts. This largely prevents the above-mentioned sources of error. The mounting components allow so much room for movement that heat expansion will not result in lateral loading.

Lateral forces which are generated by wind, acceleration or conveyor friction can be diverted by guide elements or stops.

Guide elements must be installed perpendicular to the measuring direction to ensure that no force components are generated in the measuring direction. The guide elements must be installed such that they do not stretch if, for example, the mounting points spread apart. This is easily achieved by arranging the guide elements in the same direction of rotation.

Ensure that the selected guide elements comply with the principles applicable to weighing technology.

Force bypasses must not arise due to filling and emptying devices or supply lines.

## 4.3 Lengthening and shortening the connecting cable

Load cells can be equipped with connecting cables with four or six cores.

---

### Note

#### Measurement errors

Connecting cables are only permitted to be extended using electro-magnetically compatible housings, such as the SIWAREX JB junction box.

---

### Single load cells

If a scale is equipped with a single load cell, the scale can be directly connected to the weighing module if space permits. To bridge longer distances, the connecting cable can be extended using a junction box.

Several load cells are connected in parallel in a junction box.

### Connecting cable in four-wire system

---

#### Note

#### No calibration approval

In scales requiring official calibration, the connecting cables for load cells in a four-wire system must not be shortened or lengthened.

---

When the length of the connecting cable is altered, the input and output resistance changes. This change can be corrected by adjusting the scale, but temperature-dependent resistance changes are not compensated for the missing or additional length of cable.

The value of the residual temperature error is presented in the diagram below. The investigation was based on the SIWAREX measurement cable 7MH4702-8AG / -8AF. The supply cables are connected in parallel (double).

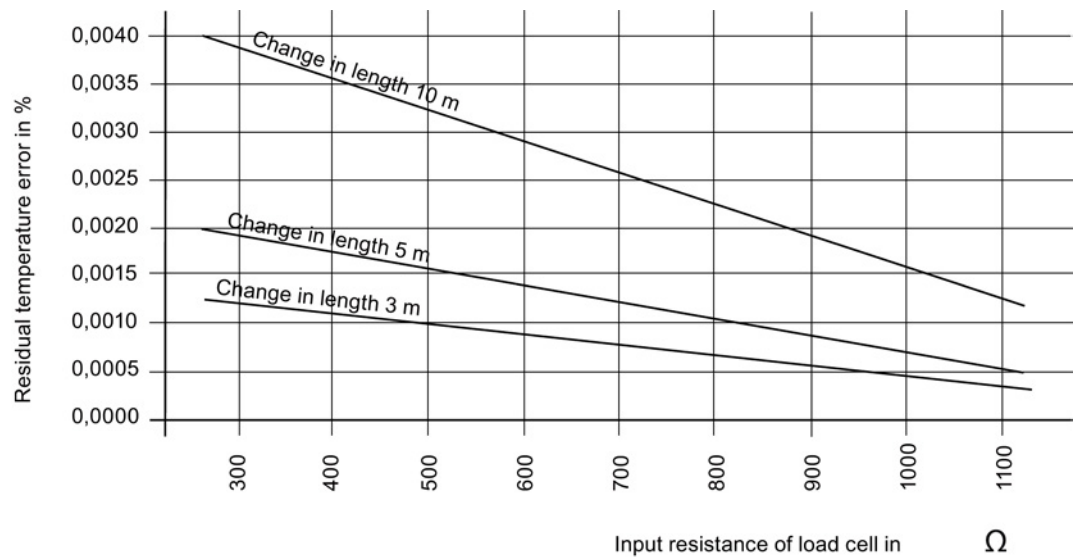

Figure 4-1 Residual temperature error for a load cell per 10 K temperature change when shortening or lengthening the connecting cable

If three or four load cells are operated in parallel and the cable for a cell is lengthened, the additional error is approximately one third or one quarter. This assumes that the load is distributed evenly across the load cells.

### Connecting cable in six-wire system

For connecting cables in the six-wire system, the supply voltage is fed back to the weighing module as the reference voltage. Shortening or lengthening has no effect on the measuring result.

### Additional connecting cables

The maximum permissible cable length between the load cell and the weighing module is stated in the technical specifications for the weighing module. In Ex applications, you must also take into account the specifications of the Ex i interface.

For connecting the junction box to the weighing module, to extend a load cell connecting cable or for cross-connection of two junction boxes, a shielded, six-core cable must be used, e.g. Li2Y2x0.75St+2x(2x0.34St)-CY Siemens Order No.: 7MH4 702-8AG or, for intrinsically safe Ex applications, 7MH4 702-8AF.

Further information: see section: Accessories (Page 102)



## Mounting and connecting

### 5.1 Safety information/instructions

#### 5.1.1 General safety instructions

Load cells are precision components and must therefore be handled carefully. Particular care must be taken during transport and installation.

 <b>WARNING</b>
<b>Danger to life from falling loads</b> <ul style="list-style-type: none"><li>• Load cells are not machine components which have been constructed with the normal safety factors. For this reason, appropriate protection against falling and catastrophes must be implemented in accordance with the potential risks.</li><li>• Use suitable hoisting equipment to lift the load carrier. Observe the appropriate safety regulations.</li></ul>

<b>NOTICE</b>
<b>Damage to load cells through incorrect handling</b> <ul style="list-style-type: none"><li>• SIWAREX load cells are only permitted to be mounted and connected by qualified personnel.</li><li>• Mechanical shocks or falls can irreparably damage the load cell.</li><li>• When mounting the load cell, ensure that you do not damage or cut the cables of the load cell. Load cells must not be carried by their connecting cables.</li><li>• Protect the load cells from shocks and welding currents. Replace the load cells with dummies until the installation work on the scale structure is completed.</li></ul>

**NOTICE**

**Damage to load cells through high currents**

- If welding is undertaken after the load cells have been installed, ensure that the welding current is not diverted through the load cells.
  - You can do this by attaching the grounding clamp of the welding unit making reliable contact close to the weld.
  - Bridge the load cells with a ground cable, see Accessories (Page 102)
  - Disconnect the individual load cells.
- Undesirable electrical currents can arise during lightning. To protect the load cell against such currents, bridge the load cells using highly flexible grounding cables, see also Accessories (Page 102).

**NOTICE**

**Damage to load cells through incorrect mounting**

- Provide indented claws or crane eyebolts on the load carrier to ensure that hoisting gear can be used safely.
- Load cells must never be overloaded. Put the load carrier down slowly for this reason. With load cells of smaller rated loads in particular, there is a risk of stretching the load cell bodies when attaching force transfer devices, e.g. when tightening locknuts.
- Adjust the existing overload protection to ensure that it can still reliably sense transfer of the required load. The overload protection must permit a rise in weight unhindered until the setpoint weight is reached.
- Protect the gap between the load cell and overload protection from the build up of dirt or ice.
- The load must be introduced in the measuring direction of the load cell. Torsional and bending moments, eccentric loads and lateral forces are disturbances. These disturbances falsify the measured result and can damage the load cell if the permissible limits of the load cell and mounting components are exceeded.

The mounting components normally allow so much room for movement that heat expansion will not result in lateral loading.



## 5.1.2 Safety instructions when connecting in hazardous areas

### Protection against explosion

 <b>WARNING</b>
<p><b>Risk of explosion</b></p> <p>For applications in hazardous areas please observe the following information as otherwise there is a risk of explosion.</p> <p>If used in hazardous areas the device requires an ATEX approval with test certification. The technical specifications include a list of approvals for SIWAREX WL200 load cells. The information in these documents must be observed when using the load cells in hazardous areas.</p> <p>Keep to the national regulations and laws applicable in your country when making electrical connections in hazardous areas. In Germany, these include, for example:</p> <ul style="list-style-type: none"><li>• Operational safety regulation</li><li>• The directive for "Installation of electrical systems in hazardous areas", DIN EN 60079-14 (previously VDE 0165,T1)</li><li>• The EC type examination certificate</li></ul> <p>If auxiliary power is required, check that it corresponds with that on the rating plate and with the test certification valid for your country.</p>

**Zone 0 and 20 in type of protection "ia/ib" intrinsic safety**

- Only connect the transmitter, in accordance with the certificate of compliance, to devices certified as intrinsically safe.

 <b>WARNING</b>
<p><b>Risk of explosion and loss of ATEX approval</b></p> <p>Only connect the device to certified intrinsically safe circuits. These circuits must comply with the technical data specified on the rating plate, or in the certificates and approvals. If the circuits do not correspond with the information in the certificates and approvals, the safety which is required for approval can no longer be warranted. The "ia" protection level of the device is decreased to the "ib" protection level when intrinsically safe circuits having the "ib" protection level are connected.</p>

Be sure to observe the respective values.

For SIWAREX WL230, WL250, WL260, WL270 CP-S SA, WL270 CP-S SB

Maximum values of the auxiliary power supply and signal circuit		
U <sub>i</sub> = 20 V DC	I <sub>i</sub> = 600 mA	P <sub>i</sub> = 6 W
L <sub>i</sub> = 40 µH	C <sub>i</sub> = 12 nF	

For SIWAREX WL270 K-S CA, WL280

Maximum values of the auxiliary power supply and signal circuit		
U <sub>i</sub> = 20 V DC	I <sub>i</sub> = 600 mA	P <sub>i</sub> = 6 W
L <sub>i</sub> = 40 µH	C <sub>i</sub> = 12 nF	

**Zone 2 in protection type "ic"**

- Connect the transmitter only to devices that have been approved as at least "ic" certified (intrinsically safe) devices in category 3.
- Be sure to observe the respective values.

For SIWAREX WL270 K-S CA, WL280

Maximum values of the auxiliary power supply and signal circuit		
U <sub>i</sub> = 20 V DC	I <sub>i</sub> = 600 mA	P <sub>i</sub> = 6 W
L <sub>i</sub> = 40 µH	C <sub>i</sub> = 12 nF	

### Zone 2 in type of protection "nL" - limited energy resources

- Connect the load cell only to devices that have been approved as "nL" certified devices (limited energy resources) in category 3.
- Note the permissible values in each case according to the prototype test certificate FM09ATEX0040X and FM09ATEX0041X.

For SIWAREX WL230, WL250, WL260, WL270 CP-S SA, WL270 CP-S SB

Maximum values of the auxiliary power supply and signal circuit		
$U_i = 20 \text{ V DC}$	$I_i = 600 \text{ mA}$	$P_i = 6 \text{ W}$
$L_i = 40 \text{ } \mu\text{H}$	$C_i = 12 \text{ nF}$	

### Zone 2 in type of protection "nA" - non-sparking equipment

- Adhere to the conditions for installers applicable to this type of protection.
- The maximum approved input voltage is  $U_n = 35 \text{ V DC}$ .
- Take measures to ensure that the supply voltage (including transients) does not rise above 140% of the rated voltage.

For SIWAREX WL70 K and SIWAREX WL280 RN

Maximum values of the auxiliary power supply and signal circuit		
$U_i = 20 \text{ V DC}$	$I_i = 600 \text{ mA}$	$P_i = 6 \text{ W}$
$L_i = 40 \text{ } \mu\text{H}$	$C_i = 12 \text{ nF}$	

## 5.2 Installation

 <b>WARNING</b>
<b>Danger to life from falling loads</b> Load cells are not machine components which have been constructed with the normal safety factors. For this reason, appropriate protection against falling and catastrophes must be implemented in accordance with the potential risks.
<b>NOTICE</b>
<b>Destruction of load cells</b> Proceed carefully with installation. The load cells can be destroyed if they are installed incorrectly.

### Marking of application area on ATEX plate

The types of protection for which the load cell is certified are indicated on the ATEX plate. See Rating plate and ATEX plate (Page 20)

Prior to commissioning the irrelevant types of protection on the ATEX plate have to be permanently erased. In the event of a power supply that is not intrinsically safe or if the load cell has not been supplied with intrinsically safe power the type of protection - intrinsically safe is no longer valid.

### Procedure for mounting the device

1. Observe the installation guidelines for the mounting components.
  - You will also find dimension drawings for mounting components at (\*\* NO TRANSLATION IN THIS VERSION! \*\*) (Page 75)
  - Lay the cables for the load cells through cable glands in the form of a vertical downwards loop to discourage the penetration of water.
2. Check that the load cells and mounting components are installed correctly, e.g. by checking the mounting dimensions and oscillation distances.

## 5.3 Connecting principle

Load cells can be equipped with connecting cables with four or six cores.

 <b>WARNING</b>
<b>Risk of explosion</b> Please observe that in the case of shielded cables of intrinsically safe circuits in hazardous areas only one grounding is permissible. If grounding is to be on both sides an equipotential bonding conductor with at least 4 mm <sup>2</sup> must be connected.

### Load cells with four-wire system

Do not shorten or lengthen connecting cables in the four-wire system, because the cable resistance is temperature compensated. When the length of the connecting cable is altered, the input and output resistances change. This change can be corrected by adjusting the scale, but temperature-dependent resistance changes are not compensated for the missing or additional length of cable.

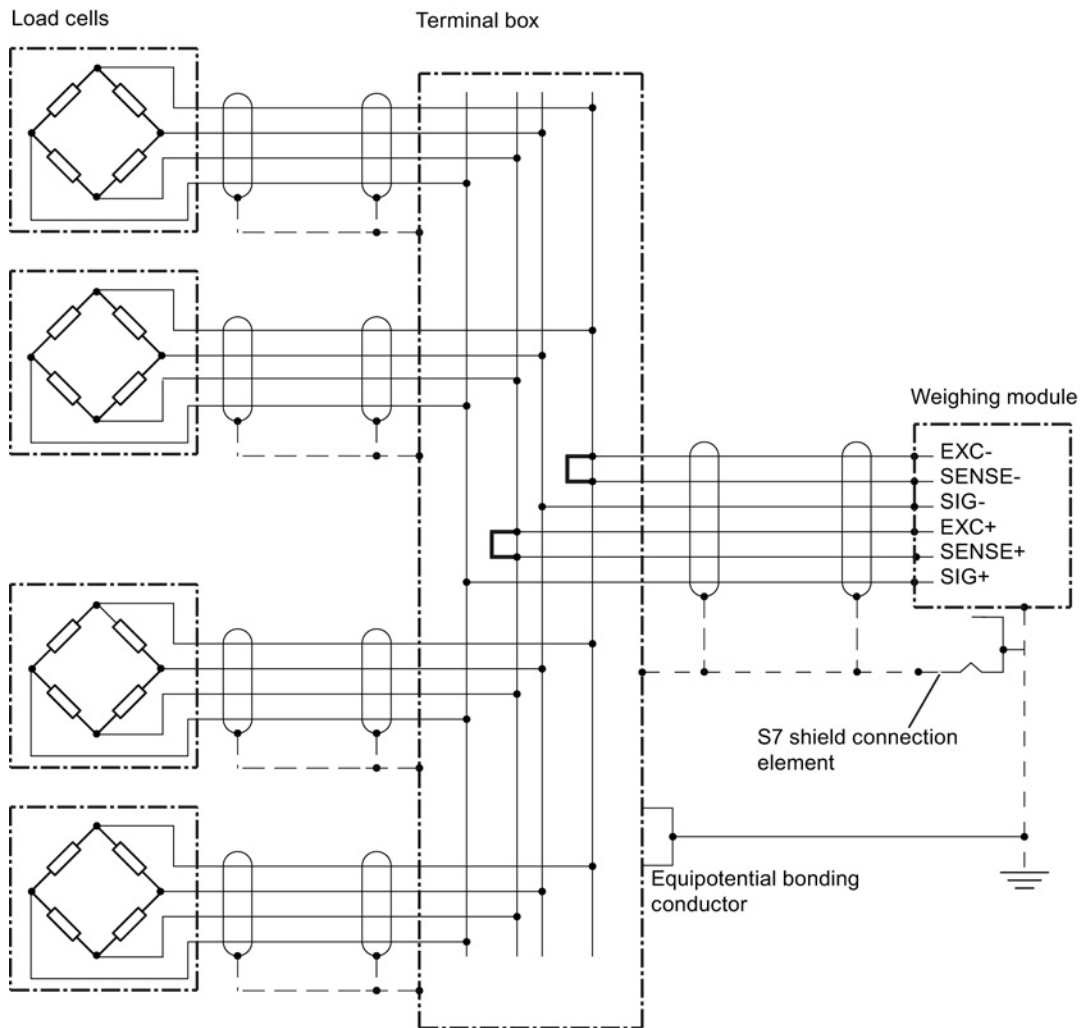

Figure 5-1 Connecting principle for load cells with four-wire system

**Note**

**No calibration approval**

In scales requiring official calibration, the connecting cables for load cells in a four-wire system must not be shortened or lengthened.

### Load cells with six-wire system

For connecting cables in the six-wire system, the supply voltage is fed back to the weighing module as the reference voltage. Shortening or lengthening has no effect on the measuring result.

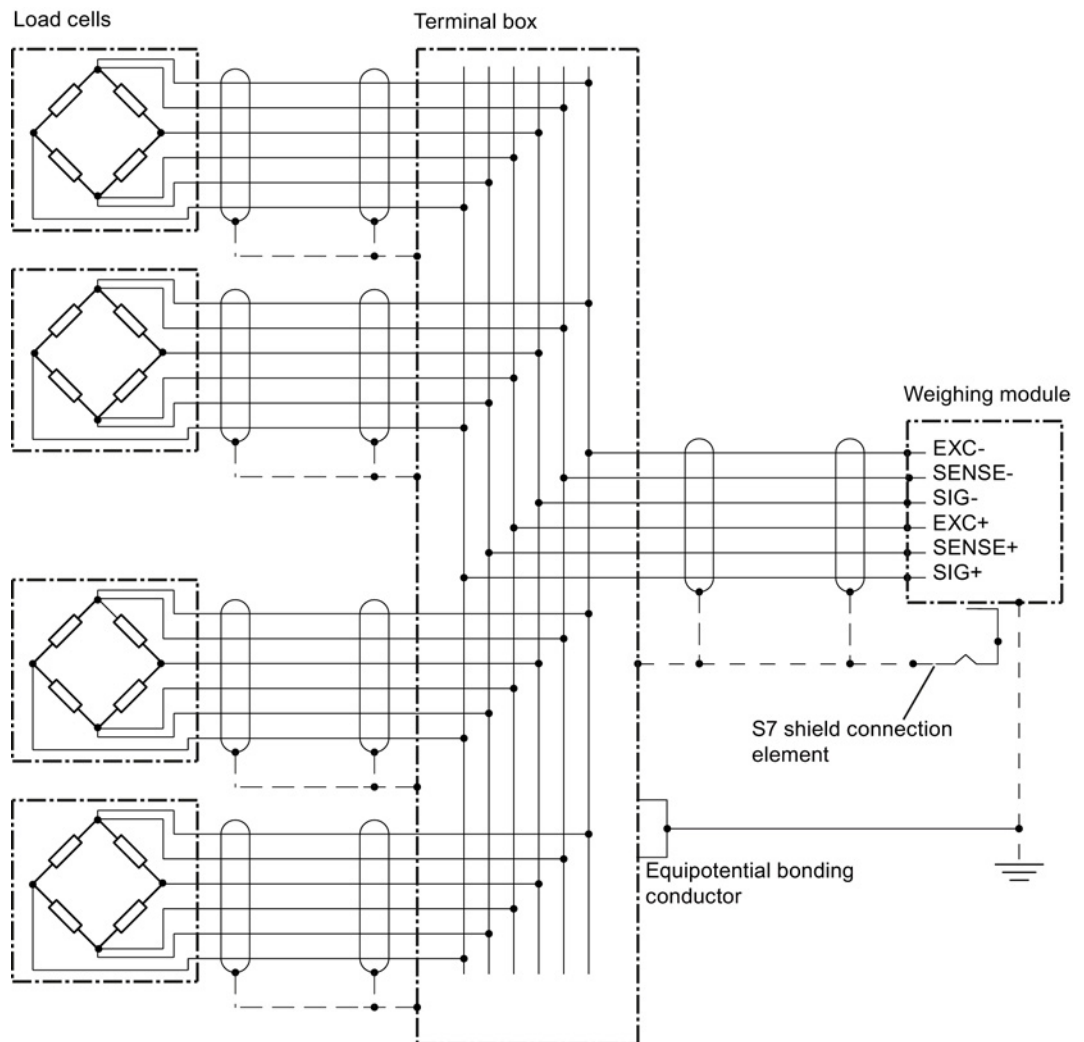

Figure 5-2 Connecting principle for load cells with six-wire system

## 5.4 Connecting up

### Signal assignment for the load cell connecting cable

Table 5- 1 Identifying colors and signal assignment for the load cell connecting cable

Load cell	Connecting cable	
	Function	Color
SIWAREX WL260 SP-S AA	EXC+	Red
	EXC-	Black
	SIG+	Green
	SIG-	White
	Sense+	Blue
	Sense-	Brown
	Shield	Transparent
SIWAREX WL260 SP-S AB	EXC+	Red
	EXC-	Black
	SIG+	Green
	SIG-	White
	Sense+	Blue
	Sense-	Brown
	Shield	Transparent
SIWAREX WL260 SP-S SA	EXC+	Green
	EXC-	Black
	SIG+	White
	SIG-	Red
	Sense+	Yellow
	Sense-	Blue
	Shield	Transparent
SIWAREX WL260 SP-S SB	EXC+	Green
	EXC-	Black
	SIG+	White
	SIG-	Red
	Sense+	Yellow
	Sense-	Blue
	Shield	Transparent



Load cell		Connecting cable	
		Function	Color
SIWAREX WL260 SP-S SC			
10 to 50 kg	EXC+	Red	
	EXC-	Black	
	SIG+	Green	
	SIG-	White	
	Sense+	Blue	
	Sense-	Yellow	
	Shield	Transparent	
100 to 200 kg	EXC+	Red	
	EXC-	Black	
	SIG+	Green	
	SIG-	White	
	Shield	Transparent	
SIWAREX WL250 ST-S SA		EXC+	Red
		EXC-	Black
		SIG+	Green
		SIG-	White
		Shield	Transparent
SIWAREX WL230 BB-S SA		EXC+	Green
		EXC-	Black
		SIG+	White
		SIG-	Red
		Shield	Transparent
SIWAREX WL230 SB-S SA		EXC+	Green
		EXC-	Black
		SIG+	White
		SIG-	Red
		Shield	Transparent
SIWAREX WL270 CP-S SA		EXC+	Red
		EXC-	Black
		SIG+	Green
		SIG-	White
		Shield	Transparent

Load cell	Connecting cable	
	Function	Color
SIWAREX WL270 CP-S SB	EXC+	Green
	EXC-	Black
	SIG+	White
	SIG-	Red
	Sense+	Yellow
	Sense-	Blue
	Shield	Transparent
SIWAREX WL270 CP-S SC	EXC+	Green
	EXC-	Black
	SIG+	White
	SIG-	Red
	Shield	Transparent
SIWAREX WL270 K-S CA	EXC+	Red
	EXC-	White
	SIG+	Black
	SIG-	Blue
	Shield	Transparent
SIWAREX WL280 RN-S SA	EXC+	Pink
	EXC-	Gray
	SIG+	Brown
	SIG-	White
	Shield	Transparent

Identifying colors and signal assignment for the connecting cables of load cells not listed:  
See the data sheet for the appropriate load cell.

**Procedure**

**Note**

**Measurement errors**

Please note the warnings against extending or shortening the connecting cables in Section Lengthening and shortening the connecting cable (Page 28)

If at all possible, do not shorten the connecting cables in a four-wire system.

**Note**

**No calibration approval**

In scales requiring official calibration, the connecting cables for load cells in a four-wire system must not be shortened or lengthened.

1. Connect the recommended grounding cables. See Section Planning (Page 23)
2. Connect up the load cells in accordance with the connection principle and with reference to the specified signal assignments. For details, see section Connecting principle (Page 37)
3. For load cells with a four-wire system, position the jumpers in the junction box as follows:

Jumper	From terminal	To terminal
1	EXC-	SENSE-
2	EXC+	SENSE+

**Note**

**Malfunction**

The SIWAREX weighing module signals a wire break when the jumpers are missing.

## **5.5 Dismantling**

For the disassembly of load cells, the same safety rules and requirements apply as for installation and assembly.

1. Disconnect all the supply voltages and auxiliary voltages.
2. Secure the load carrier against falling.
3. Use appropriate hoisting gear and tools.
4. Take the load off the load cell.
5. Carefully remove the load cell without using force. Do not pull on the cable of the load cell.
6. Do not cut the cable if the load cell is to be re-used or sent in for repair.
7. Do not carry the load cell by the cable.

## Adjustment and initial commissioning

 <b>WARNING</b>
<p><b>Missing type of protection and loss of approval</b></p> <p>If the load cell is not operated with an intrinsically safe power supply, the type of protection - intrinsically safe is no longer guaranteed and the intrinsically safe approval may be revoked.</p> <p>Permanently erase, therefore, the irrelevant types of protection on the rating plate before commissioning, so that erroneous deployment can be avoided.</p>

## **6.1 Height compensation**

### **6.1.1 When is height compensation necessary?**

If you are using up to three load cells, all the load cells will always be under load. Height compensation is not necessary in this case.

When an elastic base or elastic foundations are used, the height from the base or foundations is compensated. Height compensation is not necessary in this case.

For more than three load cells or support points, the load bearing is statically indeterminate. When the foundation and the base are rigid, the total weight can load two diagonally mounted load cells and cause overloading of the load cells. Height compensation is necessary in this case.

### **6.1.2 Procedure for height compensation**

#### **Determining the load on the load cells**

1. Bring the force transfer points to the same height.

The output signals for all load cells should be approximately identical when the load is evenly distributed; and they will indicate the load distribution in the case of uneven distribution.

2. Measure the loading on the load cells as follows:
  - Disconnect the load cell cables SIG+ and SIG-.
  - Connect the supply voltage, e.g. 10.2 V, to the load cells.
  - Measure the output voltages between SIG+ and SIG- for the individual load cells.
3. Determine which load cell has the lowest output voltage.

#### **Height compensation of the load cells**

1. Insert as many distance plates underneath the load cell with the lowest value as necessary to equalize the output voltages.

## 6.2 Initial commissioning

1. Align the load cell site horizontally and level over the complete area.
2. Clean the load cell site and load cell base until both are absolutely clean.
3. Grease the contact surfaces of the force transfer elements with bearing grease.
4. Adjust the overload protection, if used, to ensure that it can still reliably sense transfer of the required load. The overload protection must permit a rise in weight unhindered until the setpoint weight is reached.
5. Ensure dirt and ice cannot build up on the overload protection.

## 6.3 Corner load adjustment

### 6.3.1 When is corner load adjustment necessary?

SIWAREX load cells are current-calibrated as standard. The type series WL250 and WL260 are the exception. Corner load adjustment is not necessary in the case of current-calibrated load cells.

This may not apply to load cells that are available outside the standardized delivery spectrum. For these load cell types, the relevant technical specifications apply.

Corner load adjustment is only necessary in the case of load cells that are not current-calibrated or load cells that are not synchronized.

### 6.3.2 General procedure for corner load adjustment

The load cells are passive sensors: You should therefore follow the instructions in the manual for the weighing module primarily. When they are installed in hazardous areas, the instructions for the Ex i interface or for the Ex barrier must also be followed.

When the corner load for a scale has to be checked, impermissibly large deviations in the weight indication can occur in the case of load cells that are not current-calibrated.

The corner load errors can be electrically compensated. This is done by matching the individual measured values to the smallest measured value by connecting additional resistors. For details of how to do this see section Example for corner load adjustment (Page 48)

The resistors are connected in series with the load cell measuring signal. The appropriate resistor will reduce the measuring voltage until it is equal to the smallest voltage. The temperature coefficient must be suitably small, due to connection of the resistors in the measuring circuit: 0.25 ppm/K to 10 ppm/K.

### 6.3.3 Example for corner load adjustment

#### Example data for corner load adjustment

Variable	Value / Design
Scale design	Platform scale with 4 load cells
Rated load $E_{max}$	500 kg
Rated characteristic value $C_{Rated}$	2.0 mV/V
Test weight	150 kg

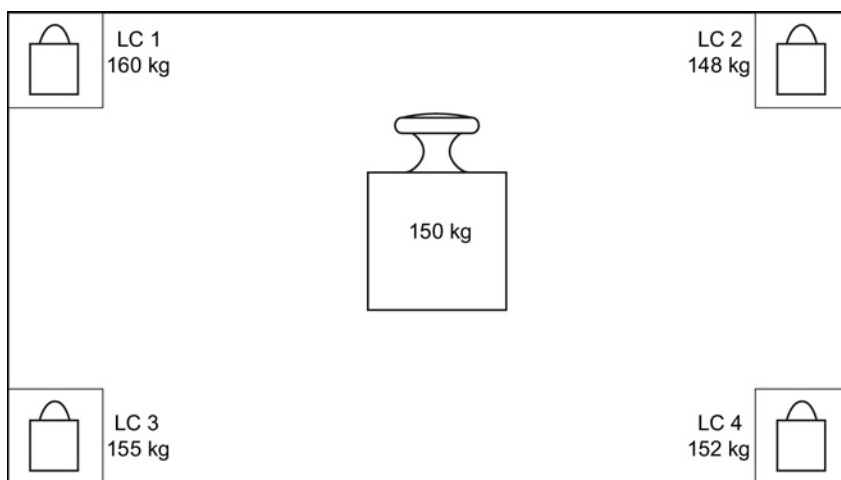

Figure 6-1 Test layout

#### Procedure

- Measure the output resistances  $R_a$  for the load cells LC or obtain the values from the corresponding data sheet

LC 1: 1004.52  $\Omega$

LC 2: 1003.64  $\Omega$

LC 3: 1010.70  $\Omega$

LC 4: 1028.12  $\Omega$

- Place the test weights on all four corners and note the values:

LC 1: 160 kg

LC 2: 148 kg

LC 3: 155 kg

LC 4: 152 kg



- Determine the differences from the lowest value

Lowest value:	LC 2:	= 148 kg
LC 1 - LC 2:	160 kg - 148 kg	= 12 kg
LC 3 - LC 2:	155 kg - 148 kg	= 7 kg
LC 4 - LC 2:	152 kg - 148 kg	= 4 kg

- Calculate the compensating resistances:

$$R_{\text{comp}} = R_o \times L_{\text{err}} / L_{\text{test}}$$

$R_{\text{comp}}$ : Determined compensation resistance, to be connected in the measuring lead SIG+

$R_o$ : Output resistance of the load cells; can also be measured under load

$L_{\text{err}}$ : Weight error: Differential value from the lowest weight value

$L_{\text{test}}$ : Test load; placed on all four corners

LC 1:	$R_{\text{comp}} = R1$	= 1004.52 $\Omega$ x 12 kg / 150 kg	approx. 80 $\Omega$
LC 2:	Lowest value	No resistance necessary	
LC 3:	$R_{\text{comp}} = R3$	= 1010.70 $\Omega$ x 7 kg / 150 kg	approx. 47 $\Omega$
LC 4:	$R_{\text{comp}} = R4$	= 1028.12 $\Omega$ x 4 kg / 150 kg	approx. 27 $\Omega$

- Install the calculated resistances
- Repeat the test

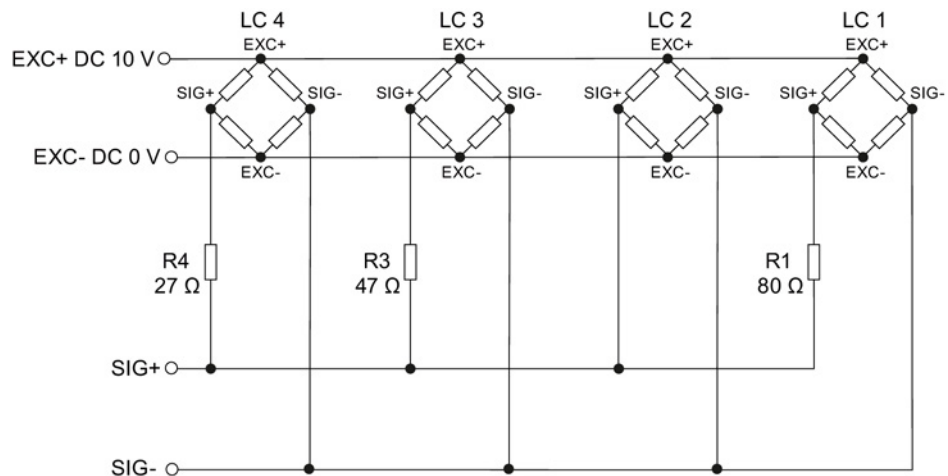

Figure 6-2 Circuit diagram for corner load adjustment



## Servicing and maintenance

### Servicing and maintenance of the load cells

The load cells are in general maintenance free. Regular inspection and checking of the mechanisms for force transfer, oscillation limitation, lifting and overloading will however improve their reliability. The inspections should also be performed after serious environmental events such as storms, floods or earthquakes.

If signs of corrosion appear, we recommend a suitable protective coating.

<b>NOTICE</b>
<b>Damage to load cells, measurement errors</b>
<ul style="list-style-type: none"><li>• Dirt must not be allowed to accumulate in the vicinity of a load cell.</li><li>• Do not subject cable glands and seals to the jet from a high-pressure hose.</li></ul>



### Regular maintenance of overload protection

Overload protection mechanisms must be protected against deposits of dirt and ice.

The correct operation of overload protection must be tested during periodic maintenance work.



## Error messages and troubleshooting

### 8.1 Repair

---

**Note****Unnecessary costs for repairs**

Please only return faulty load cells to our repair center accompanied by an accurate description of the fault. This simplifies the diagnostics.

---

### 8.2 Error messages

#### Rated load exceeded

If load cells are loaded beyond their rated load, this can result in an error message in the weighing module.

When step changes in load cannot be excluded during measuring, for example, due to application of a load in free fall, appropriate precautions to avoid damage to the load cell must be made, e.g. by using elastomer bearings or load cells dimensioned for higher rated loads.

#### Wire break

The weighing module reports a wire break if the jumpers are not installed in load cells with four-wire technology. For details, see section Connecting up (Page 40).

### 8.3 Checking the mechanical and electrical configuration

In the case of faulty measurements, check the following:

- Do any force bypasses exist, e.g. due to cables, pipes or guides, that generate forces in the measuring direction?
- Are there any other disturbances due to soiling or thermal expansion?
- Have all load cells been correctly aligned horizontally and at the same height?
- Has moisture penetrated the junction box?
- Are the cables connected correctly?
- Are the cables damaged?

## 8.4 Checking the load cells

<b>NOTICE</b>
<b>Damaging of load cells</b>
Do not use an Ohmmeter to measure resistances that feeds a higher voltage into the load cell than is permitted in the specifications.

### Locate and check faulty load cells

1. Locate the possibly faulty load cell by checking the individual load cells under load, corner load or by disconnecting the individual load cells.
2. To check a load cell for a defect, you must measure the following values:
  - Zero signal
  - Insulation resistance
  - Input and output resistance
  - Jumper resistance

The procedure for measuring the individual values is described below.

### Measure the zero signal

1. Completely remove the load from the load cell to be checked.
2. Disconnect all the load cells.
3. Supply the load cell to be checked with approximately 10 V DC. Use the weighing module or an external power supply for this purpose.
4. Measure the voltage between SIG+ and SIG-.
5. Divide the measured voltage by the supply voltage.

The result must correspond to the value in the data sheet.

### Measure the insulation resistance

1. Disconnect the load cell.
2. Connect all cables together.
3. Measure the insulation resistance between the cables and the load cell housing.
4. Measure the insulation resistance between the cables and the cable shield.
5. The following measurement is only possible when the shield is not connected to the load cell housing.

Measure the insulation resistance between the cable shield and the load cell housing.

The insulation resistance must correspond to the value specified in the specifications.

### **Measure the input and output resistance**

1. Disconnect the load cell.
2. Measure the input voltage between EXC+ and EXC-.
3. Measure the output voltage between SIG+ and SIG-.

The resistances must correspond to the values specified in the data sheet or in the specifications.

### **Measure the jumper resistance**

1. Disconnect the load cell.
2. Measure the resistance between SIG- and EXC-.
3. Measure the resistance between SIG+ and EXC+.
4. The difference between the two values must be no greater than 1  $\Omega$ .

## **8.5 Measures in the event of overloaded load cells**

A frequent fault that can result in failure of load cells is overloading due to

- dynamic overload
- transverse forces

When you establish that the cause of the fault was overloading, further measures are necessary.

### **Dynamic overload**

Example:

Unintentional falling of a relatively low weight onto the load carrier from a great height.

Possible measure:

- Install shock-absorbing components, e.g. elastomer bearings
- Overdimension the load cells

### **Transverse forces**

Example:

Accelerating or braking loads onto a platform.

Possible measures:

- Install guide elements
- Install oscillation limitation or set it to a lower value.



## Technical data

### 9.1 Functional data

#### 9.1.1 SIWAREX WL260 SP-S AA

Variable		Value
Type series		WL260
Designation		SP-S AA
Construction type		Single point load cell
Possible applications		Platform scales, small conveyor scales
Rated load $E_{max}$		3; 5; 10; 20; 50; 100 kg
Accuracy class according to OIML R60		C3
Max. scale interval $n_{LC}$		3000
Min. scale interval $V_{min}$	for $E_{max} = 3; 5; 10$ kg for $E_{max} = 20; 50$ kg for $E_{max} = 100$ kg	$E_{max} / 15000$ $E_{max} / 7500$ $E_{max} / 12000$
Combined error $F_{comb}$		$\pm 0.02\% C_n$
Deviation $F_V$		$\pm 0.017\% C_n$
Creepage error $F_{cr}$ 30 min		$0.02\% C_n$
Temperature coefficient	Characteristic value $T_{Kc}$ Zero signal $T_{Ko}$	$0.014\% C_n / 10$ K $0.017\% C_n / 10$ K
Min. initial loading $E_{min}$		0 kg
Maximum working load $L_u$		$150\% E_{max}$
Break load $L_d$		$300\% E_{max}$
Maximum lateral load $L_{lq}$		$100\% E_{max}$
Rated measuring path $h_n$ at $E_{max}$		$\leq 0.6$ mm
Recommended supply voltage		5 to 12 V DC
Rated characteristic value $C_{Rated}$		$2.0 \pm 0.2$ mV/V
Tolerance of zero signal $D_o$		$< \pm 2.0\% C_n$
Input resistance $R_i$		$409 \pm 6$ $\Omega$
Output resistance $R_o$		$350 \pm 3$ $\Omega$
Insulation resistance $R_{is}$		5000 M $\Omega$ at 50 V DC
Rated temperature range $B_{In}$		- 10 ... + 40 °C
Operating temperature range $B_{tu}$		- 35 ... + 65 °C
Storage temperature range $B_{ts}$		- 35 ... + 65 °C
Sensor material		Aluminum
Degree of protection according to EN 60 529		IP65
Maximum tightening torque of the fixing screws		15 ... 20 Nm
Cable connection		Six-core, shielded, 3 m

9.1.2 SIWAREX WL260 SP-S AB

Variable	Value
Type series	WL260
Designation	SP-S AB
Construction type	Single point load cell
Possible applications	Platform scales, small conveyor scales
Rated load $E_{max}$	50; 100; 200; 500 kg
Accuracy class according to OIML R60	C3 <sup>1)</sup>
Max. scale interval $n_{LC}$	3000
Min. scale interval $V_{min}$	$E_{max} / 10000$
Combined error $F_{comb}$	$\pm 0.02\% C_n$
Deviation $F_v$	$\pm 0.017\% C_n$
Creepage error $F_{cr}$ 30 min	$0.02\% C_n$
Temperature coefficient Characteristic value $T_{Kc}$ Zero signal $T_{K0}$	$0.014\% C_n / 10 K$ $0.017\% C_n / 10 K$
Min. initial loading $E_{min}$	0 kg
Maximum working load $L_u$	$150\% E_{max}$
Break load $L_d$	$300\% E_{max}$
Maximum lateral load $L_{lq}$	$100\% E_{max}$
Rated measuring path $h_n$ at $E_{max}$	$\leq 1.22 \text{ mm}$
Recommended supply voltage	5 to 12 V DC
Rated characteristic value $C_{Rated}$	$2.0 \pm 0.2 \text{ mV/V}$
Tolerance of zero signal $D_0$	$< \pm 2.0\% C_n$
Input resistance $R_i$	$409 \pm 6 \Omega$
Output resistance $R_o$	$350 \pm 3 \Omega$
Insulation resistance $R_{is}$	$5000 \text{ M}\Omega$ at 50 V DC
Rated temperature range $B_{tn}$	- 10 ... + 40 °C
Operating temperature range $B_t$	- 35 ... + 65 °C
Storage temperature range $B_{ts}$	- 35 ... + 65 °C
Sensor material	Aluminum
Degree of protection according to EN 60 529	IP65
Maximum tightening torque of the fixing screws	35 ... 40 Nm
Cable connection	Six-core, shielded, 3 m

<sup>1)</sup> Type approval to OIML for SIWAREX WL260 SP-S AB available soon

### 9.1.3 SIWAREX WL260 SP-S SA

Variable	Value
Type series	WL260
Designation	SP-S SA
Construction type	Single point load cell
Possible applications	Platform scales, conveyor scales
Rated load $E_{max}$	5; 10; 20; 50; 100; 200 kg
Accuracy class according to OIML R60	C3 <sup>1)</sup>
Max. scale interval $n_{LC}$	3000
Min. scale interval $V_{min}$	$E_{max} / 7500$
Combined error $F_{comb}$	$\pm 0.02\% C_n$
Deviation $F_V$	$\pm 0.017\% C_n$
Creepage error $F_{cr}$ 30 min	$0.02\% C_n$
Temperature coefficient Characteristic value $T_{Kc}$ Zero signal $T_{K0}$	$0.014\% C_n / 10 K$ $0.017\% C_n / 10 K$
Min. initial loading $E_{min}$	0 kg
Maximum working load $L_u$	$150\% E_{max}$
Break load $L_d$	$300\% E_{max}$
Maximum lateral load $L_{lq}$	$100\% E_{max}$
Rated measuring path $h_n$ at $E_{max}$	$0.27 \pm 0.05 mm$
Recommended supply voltage	5 to 12 V DC
Rated characteristic value $C_{Rated}$	$2.0 \pm 0.2 mV/V$
Tolerance of zero signal $D_0$	$< \pm 1.0\% C_n$
Input resistance $R_i$	$383 \pm 4 \Omega$
Output resistance $R_o$	$351 \pm 2 \Omega$
Insulation resistance $R_{is}$	$5000 M\Omega$ at V DC
Rated temperature range $B_{in}$	- 10 ... + 40 °C
Operating temperature range $B_{tu}$	- 35 ... + 65 °C
Storage temperature range $B_{ts}$	- 40 ... + 70 °C
Sensor material	Stainless steel
Degree of protection according to EN 60 529	IP67
Maximum tightening torque of the fixing screws for $E_{max} = 5; 10; 20; 50; 100 kg$ for $E_{max} = 200 kg$	14 Nm 16 Nm
Cable connection	Six-core, shielded, 1 m

<sup>1)</sup> Type approval to OIML for SIWAREX WL260 SP-S SA available soon

9.1.4 SIWAREX WL260 SP-S SB

Variable	Value
Type series	WL260
Designation	SP-S SB
Construction type	Single-point load cell
Possible applications	Single-point scales, conveyor scales
Rated load $E_{max}$	6; 12; 30; 60 kg
Accuracy class according to OIML R60	C3
Max. scale interval $n_{LC}$	3000
Min. scale interval $V_{min}$	$E_{max} / 15000$
Combined error $F_{comb}$	$\leq \pm 0.02\% C_n$
Deviation $F_V$	$\pm 0.02\% C_n$
Creep error $F_{cr}$ 30 min	$\leq \pm 0.0245\% C_n$
Temperature coefficient Characteristic value $T_{Kc}$ Zero signal $T_{K0}$	0.0090% $C_n / 10 K$ 0.0094% $C_n / 10 K$
Min. initial loading $E_{min}$	0 kg
Maximum working load $L_u$	150% $E_{max}$
Break load $L_d$	300% $E_{max}$
Maximum lateral load $L_{lq}$	100% $E_{max}$
Recommended supply voltage	5 to 12 V DC
Maximum supply voltage	18 V DC
Rated characteristic value $C_{Rated}$	$2.0 \pm 0.2 mV/V$
Tolerance of zero signal $D_0$	$< \pm 1.5\% C_n$
Input resistance $R_i$	$400 \pm 20 \Omega$
Output resistance $R_o$	$350 \pm 3.5 \Omega$
Insulation resistance $R_{is}$	$\geq 5000 M\Omega$ at 50 V DC
Rated temperature range $B_{tn}$	- 10 to + 40 °C
Operating temperature range $B_{tu}$	- 35 to + 65 °C
Storage temperature range $B_{ts}$	- 35 to + 65 °C
Sensor material	Stainless steel, mat. no. 1.4542
Degree of protection according to EN 60 529	IP68
Cable connection	Six-core, shielded PU cable, 6 m
Maximum tightening torque of the fixing screws	10 Nm

### 9.1.5 SIWAREX WL260 SP-S SC

Variable	Value	
Type series	WL260	
Designation	SP-S SC	
Construction type	Single-point load cell	
Possible applications	Single-point scales, conveyor scales	
Rated load $E_{max}$	10, 20, 50, 100, 200, 300, 400, 500 kg	10, 20, 50 kg
Accuracy class according to OIML R60	C3	C4
Max. scale interval $n_{LC}$	3000	4000
Min. scale interval $V_{min}$	$E_{max} / 10000^{1)}$	$E_{max} / 40000$
Combined error $F_{comb}$	$\leq \pm 0.02\% C_n$	$\leq \pm 0.014\% C_n$
Deviation $F_V$	$\pm 0.02\% C_n$	
Creep error $F_{cr}$ 30 min	$\leq \pm 0.0245\%$	$\leq \pm 0.0184\%$
Temperature coefficient	Characteristic value $T_{Kc}$ Zero signal $T_{Ko}$	$\leq \pm 0.0100\%$ $\leq \pm 0.0140\%$
Min. initial loading $E_{min}$	0 kg	0 kg
Maximum working load $L_u$	150% $E_{max}$	150% $E_{max}$
Break load $L_d$	300% $E_{max}$	300% $E_{max}$
Maximum lateral load $L_{lq}$	100% $E_{max}$	100% $E_{max}$
Rated measuring path $h_n$ at $E_{max} = 50, 100, 250, 500$ kg	$\leq 0.19$ mm	
Recommended supply voltage	5 to 12 V DC	
Maximum supply voltage	18 V DC	
Rated characteristic value $C_{Rated}$	$2.0 \pm 0.2$ mV/V	
Tolerance of zero signal $D_o$	$< \pm 2.0\% C_n$	
Input resistance $R_i$		
for $E_{max} 10, 20, 50$	$380 \pm 15 \Omega$	
for $E_{max} 100, 200, 300, 400, 500$	$350 \pm 3.5 \Omega$	
Insulation resistance $R_{is}$	$\geq 5000$ M $\Omega$ (at 50 V DC)	
Rated temperature range $B_{in}$	- 10 to + 40 °C	
Operating temperature range $B_{tu}$	- 35 to + 65 °C	
Storage temperature range $B_{ts}$	- 35 to + 65 °C	
Sensor material	Stainless steel	
Degree of protection acc. to EN 60 529	IP68, IP69K	
Cable connection	Shielded PU cable, 3 m	
Max. tightening torque of the fixing screws		
for $E_{max} = 10$ to 50 kg	10 Nm	
for $E_{max} = 100$ to 500 kg	20 Nm	

<sup>1)</sup> also available with  $E_{max} / 20000$

### 9.1.6 SIWAREX WL250 ST-S SA

Variable	Value
Type series	WL250
Designation	ST-S SA
Construction type	S type load cell
Possible applications	Tension and compression applications, suspended scales, hybrid scales, container scales
Rated load $E_{max}$	50; 100; 250; 500 kg 1; 2.5; 5; 10 t
Accuracy class according to OIML R60	C3
Max. scale interval $n_{LC}$	3000
Min. scale interval $V_{min}$	for $E_{max} = 50; 100$ kg $E_{max} / 7000$ for $E_{max} = 250; 500$ kg; 1; 2.5 t $E_{max} / 10000$ for $E_{max} = 5; 10$ t $E_{max} / 12000$
Combined error $F_{comb}$	$\pm 0.02\% C_n$
Deviation $F_v$	$\pm 0.02\% C_n$
Creepage error $F_{cr}$ 30 min	0.02% $C_n$
Temperature coefficient	Characteristic value $T_{Kc}$ 0.014% $C_n / 10$ K Zero signal $T_{K0}$ 0.017% $C_n / 10$ K
Min. initial loading $E_{min}$	0 kg
Maximum working load $L_u$	150% $E_{max}$
Break load $L_d$	300% $E_{max}$
Maximum lateral load $L_{lq}$	100% $E_{max}$
Rated measuring path $h_n$ at $E_{max}$	for $E_{max} = 50; 100$ kg 0.18 mm for $E_{max} = 250; 500$ kg 0.24 mm for $E_{max} = 1$ t 0.37 mm for $E_{max} = 2.5; 5$ t 0.8 mm for $E_{max} = 10$ t 0.57 mm
Recommended supply voltage	5 to 12 V DC
Rated characteristic value $C_{Rated}$	3.0 $\pm$ 0.008 mV/V
Tolerance of zero signal $D_0$	$< \pm 1.0\% C_n$
Input resistance $R_i$	430 $\pm$ 60 $\Omega$
Output resistance $R_o$	350 $\pm$ 3.5 $\Omega$
Insulation resistance $R_{is}$	5000 M $\Omega$ at 50 V DC
Rated temperature range $B_{tn}$	- 10 ... + 40 °C
Operating temperature range $B_{tu}$	- 35 ... + 65 °C
Storage temperature range $B_{ts}$	- 35 ... + 65 °C
Sensor material	Stainless steel
Degree of protection according to EN 60 529	IP67
Cable connection	Four-core, shielded PU cable, 6 m

## 9.1.7 SIWAREX WL230 BB-S SA

Variable	Value
Type series	WL230
Designation	BB-S SA
Construction type	Bending beam
Possible applications	Platform scales, overhead rail scales, container weighers, conveyor scales
Rated load $E_{max}$	10; 20; 50; 100; 200; 500 kg
Accuracy class according to OIML R60	C3
Max. scale interval $n_{LC}$	3000
Min. scale interval $V_{min}$	$E_{max} / 15000$
Combined error $F_{comb}$	$\leq 0.02\% C_n$
Deviation $F_V$	$0.017\% C_n$
Creepage error $F_{cr}$ 30 min	$0.02 C_n$
Temperature coefficient Characteristic value $T_{Kc}$ Zero signal $T_{Ko}$	$0.014\% C_n / 10 K$ $0.017\% C_n / 10 K$
Min. initial loading $E_{min}$	0 kg
Maximum working load $L_u$	$150\% E_{max}$
Break load $L_d$	$300\% E_{max}$
Maximum lateral load $L_{lq}$	$100\% E_{max}$
Rated measuring path $h_n$ at $E_{max}$	0.3 mm
Recommended supply voltage	5 to 10 V DC
Rated characteristic value $C_{Rated}$	$2.0 \pm 0.02 mV/V^*$
Tolerance of zero signal $D_o$	$< \pm 1.0\% C_n$
Input resistance $R_i$	$460 \pm 50 \Omega$
Output resistance $R_o$	$350 \pm 3.5 \Omega$
Insulation resistance $R_{is}$	5000 M $\Omega$ at 50 V DC
Rated temperature range $B_{tn}$	- 10 ... + 40 °C
Operating temperature range $B_{tu}$	- 35 ... + 65 °C
Storage temperature range $B_{ts}$	- 35 ... + 65 °C
Sensor material	Stainless steel
Degree of protection according to EN 60 529	IP68
Maximum tightening torque for the fixing bolts: for $E_{max} = 10; 20; 50; 100; 200$ kg for $E_{max} = 500$ kg	23 Nm 70 Nm
Cable connection	Four-core, shielded PU cable, 3 m

\* Output is current-calibrated

9.1.8 SIWAREX WL230 SB-S SA

Variable		Value
Type series		WL230
Designation		SB-S SA
Construction type		Shear beam
Possible applications		Platform scales, overhead rail scales, container weighers, conveyor scales
Rated load $E_{max}$		500 kg; 1; 2; 5 t
Accuracy class according to OIML R60		C3 <sup>1)</sup>
Max. scale interval $n_{LC}$		3000
Min. scale interval $V_{min}$	for $E_{max} = 500$ kg	$E_{max} / 10000$
	for $E_{max} = 1; 2; 5$ t <sup>1)</sup>	$E_{max} / 15000$
Combined error $F_{comb}$		$\pm 0.02\%$ $C_n$
Deviation $F_v$		$\pm 0.02\%$ $C_n$
Creepage error $F_{cr}$ 30 min		$\pm 0.02\%$ $C_n$
Temperature coefficient	Characteristic value $T_{Kc}$	0.017% $C_n / 10$ K
	Zero signal $T_{Ko}$	0.023% $C_n / 10$ K
Min. initial loading $E_{min}$		0 kg
Maximum working load $L_u$		150% $E_{max}$
Break load $L_d$		300% $E_{max}$
Maximum lateral load $L_{lq}$		100% $E_{max}$
Rated measuring path $h_n$ at $E_{max}$	for $E_{max} = 500$ kg	0.13 mm
	for $E_{max} = 1$ t	0.21 mm
	for $E_{max} = 2$ t	0.29 mm
	for $E_{max} = 5$ t	0.38 mm
Recommended supply voltage		5 to 12 V DC
Rated characteristic value $C_{Rated}$		$2.0 \pm 0.002$ mV/V *
Tolerance of zero signal $D_o$		$< \pm 1.0\%$ $C_n$
Input resistance $R_i$		$1000 \pm 10$ $\Omega$
Output resistance $R_o$		$1004 \pm 5$ $\Omega$
Insulation resistance $R_{is}$		5000 M $\Omega$ at 50 V DC
Rated temperature range $B_{tn}$		- 10 ... + 40 °C
Operating temperature range $B_{tu}$		- 35 ... + 65 °C
Storage temperature range $B_{ts}$		- 35 ... + 65 °C
Sensor material		Stainless steel
Degree of protection according to EN 60 529		IP68
Maximum tightening torque for the fixing bolts	for $E_{max} = 500$ kg, 1 t, 2 t	150 Nm
	for $E_{max} = 5$ t	550 Nm
Cable connection	for $E_{max} = 500$ kg, 1 t	Four-core, shielded 3 m
	for $E_{max} = 2$ t, 5 t	Four-core, shielded 6 m

\* Output is current-calibrated

1) Type approval to OIML for SIWAREX WL230 SB-S SA,  $E_{max}$ : 5 t available soon



## 9.1.9 SIWAREX WL270 CP-S SA

<b>Variable</b>	<b>Value</b>
Type series	WL270
Designation	CP-S SA
Construction type	Compression load cell
Possible applications	Vehicle scales, platform scales, container weighers
Rated load $E_{max}$	10; 20; 30; 50 t
Accuracy class according to OIML R60	C3
Max. scale interval $n_{LC}$	3000
Min. scale interval $V_{min}$	$E_{max} / 10000$
Combined error $F_{comb}$	$\pm 0.02\% C_n$
Creepage error $F_{cr}$ 30 min	$\pm 0.023\% C_n$
Temperature coefficient Characteristic value $T_{Kc}$ Zero signal $T_{Ko}$	0.017% $C_n$ / 10 K 0.023% $C_n$ / 10 K
Min. initial loading $E_{min}$	0 kg
Maximum working load $L_u$	150% $E_{max}$
Break load $L_d$	150% $E_{max}$
Maximum lateral load $L_{lq}$	75% $E_{max}$
Rated measuring path $h_n$ at $E_{max}$	0.5 mm
Recommended supply voltage	5 to 12 V DC
Rated characteristic value $C_{Rated}$	$2.0 \pm 0.02$ mV/V *
Tolerance of zero signal $D_o$	$< \pm 1.0\% C_n$
Input resistance $R_i$	$700 \pm 7 \Omega$
Output resistance $R_o$	$700 \pm 7 \Omega$
Insulation resistance $R_{is}$	5000 M $\Omega$ at 50 V DC
Rated temperature range $B_{in}$	- 10 ... + 40 °C
Operating temperature range $B_{tu}$	- 35 ... + 65 °C
Storage temperature range $B_{ts}$	- 35 ... + 65 °C
Sensor material	Stainless steel
Degree of protection according to EN 60 529	IP68
Cable connection	Four-core, shielded, 15 m

\* Output is current-calibrated

9.1.10 SIWAREX WL270 CP-S SB

Variable	Value
Type series	WL270
Designation	CP-S SB
Construction type	Compression load cell
Possible applications	Container weighers
Rated load $E_{max}$	100 t
Accuracy class according to OIML R60	C3
Max. scale interval $n_{LC}$	3000
Min. scale interval $V_{min}$	$E_{max} / 9000$
Combined error $F_{comb}$	$\pm 0.02 \% C_n$
Deviation $F_V$	$\pm 0.02 \% C_n$
Creepage error $F_{cr}$ 30 min	$0.023 \% C_n$
Temperature coefficient Characteristic value $T_{Kc}$ Zero signal $T_{Ko}$	$0.017 \% C_n / 10 K$ $0.023 \% C_n / 10 K$
Min. initial loading $E_{min}$	0 kg
Maximum working load $L_u$	$150 \% E_{max}$
Break load $L_d$	$300 E_{max}$
Maximum lateral load $L_{lq}$	$10 \% E_{max}$
Rated measuring path $h_n$ at $E_{max}$	0.36 mm
Recommended supply voltage	5 to 12 V DC
Rated characteristic value $C_{Rated}$	$2.0 \pm 0.02 mV/V^*$
Tolerance of zero signal $D_o$	$< \pm 1.0 \% C_n$
Input resistance $R_i$	$700 \pm 7 \Omega$
Output resistance $R_o$	$700 \pm 7 \Omega$
Insulation resistance $R_{is}$	5000 M $\Omega$ at 50 V DC
Rated temperature range $B_{tn}$	- 10 ... + 40 °C
Operating temperature range $B_{tu}$	- 35 ... + 65 °C
Storage temperature range $B_{ts}$	- 35 ... + 65 °C
Sensor material	Stainless steel
Degree of protection according to EN 60 529	IP68
Cable connection	Six-core, shielded, 20 m

\* Output is current-calibrated

## 9.1.11 SIWAREX WL270 CP-S SC

Variable	Value
Type series	WL270
Designation	CP-S SC
Construction type	Compression load cell
Possible applications	Container weighers
Rated load $E_{max}$	200 t
Accuracy class according to OIML R60	0.1%
Combined error $F_{comb}$	0.1% $C_n$
Deviation $F_V$	$\pm 0.017\% C_n$
Creepage error $F_{cr}$ 30 min	0.02% $C_n$
Temperature coefficient Characteristic value $T_{Kc}$ Zero signal $T_{K0}$	0.014% $C_n$ / 10 K 0.017% $C_n$ / 10 K
Min. initial loading $E_{min}$	0 kg
Maximum working load $L_u$	150% $E_{max}$
Break load $L_d$	300% $E_{max}$
Maximum lateral load $L_{lq}$	10% $E_{max}$
Rated measuring path $h_n$ at $E_{max}$	0.36 mm
Recommended supply voltage	5 to 12 V DC
Rated characteristic value $C_{Rated}$	2.0 $\pm$ 0.02 mV/V *
Tolerance of zero signal $D_0$	$< \pm 1.0\% C_n$
Input resistance $R_i$	450 $\pm$ 5 $\Omega$
Output resistance $R_o$	480 $\pm$ 5 $\Omega$
Insulation resistance $R_{is}$	5000 M $\Omega$ at 50 V DC
Rated temperature range $B_{tn}$	- 10 ... + 40 °C
Operating temperature range $B_{tu}$	- 35 ... + 65 °C
Storage temperature range $B_{ts}$	- 35 ... + 65 °C
Sensor material	Stainless steel
Degree of protection according to EN 60 529	IP68
Cable connection	Four-core, shielded, 20 m

\* Output is current-calibrated

### 9.1.12 SIWAREX WL270 K-S CA

#### Low temperature range ( $\leq 130\text{ }^{\circ}\text{C}$ )

Variable	Values	
Type series	WL270	
Designation	K-S CA	
Construction type	Compression load cell	
Possible applications	Container and bin scales	
Rated load $E_{\max}$	2.8; 6; 13; 28; 60; 130; 280 t, 350 t, 500 t	
Accuracy class (0.1%)	0.1%	0.2%
Combined error $F_{\text{comb}}$	$\leq \pm 0.10\% C_n$	$\leq \pm 0.20\% C_n$
Hysteresis	$\leq \pm 0.05\% C_n$	$\leq \pm 0.10\% C_n$
Dead load output return	$\leq \pm 0.05\% C_n$	$\leq \pm 0.07\% C_n$
Creep error $F_{\text{cr}}$	30 min	$\leq \pm 0.0600\% C_n$
	20 to 30 min	$\leq \pm 0.0150\% C_n$
Temperature coefficient	Characteristic value $T_{Kc}$	$\leq \pm 0.25\% C_n / 5\text{ }^{\circ}\text{C}$
	Zero signal $T_{K0}$	$\leq \pm 0.25\% C_n / 5\text{ }^{\circ}\text{C}$
Min. initial loading $E_{\min}$	0 t	0 t
Maximum working load $L_u$	120% $E_{\max}$	
Break load $L_d$	300% $E_{\max}$	
Maximum lateral load $L_{lq}$	10% $E_{\max}$	
Rated measuring path $h_n$ at $E_{\max}$	0.23 to 3.11 mm	
Supply voltage	Recommended	5 to 12 V DC
	Maximum	15 V
Rated characteristic value $C_{\text{Rated}}$	$1.5 \pm 0.008\text{ mV/V}$	
Tolerance of zero signal $D_0$	$< \pm 1.5\% C_n$	
Input resistance $R_i$	2.8 to 280 t	$275 \pm 50\ \Omega$
	350 t, 500 t	$450\ \Omega \pm 4.5\ \Omega$
Output resistance $R_o$	2.8 to 280 t	$245\ \Omega \pm 0.2\ \Omega$
	350 t, 500 t	$480\ \Omega \pm 4.8\ \Omega$
Insulation resistance $R_{is}$	$\geq 5000\text{ M}\Omega$ at 50 V DC	
Rated temperature range $B_{tn}$	- 10 to + 40 $^{\circ}\text{C}$	
Operating temperature range $B_{tu}$	- 20 to + 70 $^{\circ}\text{C}$	
Storage temperature range $B_{ts}$	- 30 to + 80 $^{\circ}\text{C}$	
Sensor material	Steel, painted	
Degree of protection according to EN 60 529	IP66	
Cable connection: Four-core, shielded	$E_{\max} = 2.8\text{ t}, 6\text{ t}$	6 m
	$E_{\max} = 13\text{ t}, 28\text{ t}, 60\text{ t}$	15 m
	$E_{\max} = 130\text{ t}, 280\text{ t}, 350\text{ t}, 500\text{ t}$	20 m

\* Output is current-calibrated

Option: High temperature range (to max. 250 °C)

Variable		Values		
Type series		WL270		
Designation		K-S CA HT		
Construction type		Compression load cell		
Possible applications		Container and bin scales		
Rated load $E_{max}$		2.8; 6; 13; 28; 60; 130; 280 t, 350 t, 500 t		
Temperature ranges		<b>Temperature range 1</b> - 30 °C to + 150 °C	<b>Temperature range 2</b> + 150 °C to + 180 °C	<b>Temperature range 3</b> + 180 °C to + 250 °C
Rated characteristic value $C_{Rated}$		1.5 ± 0.02 mV/V	1.5 ± 0.1 mV/V	1.5 ± 0.1 mV/V
Combined error $F_{comb}$		≤ ± 0.300% $C_n$	≤ ± 0.500% $C_n$	≤ ± 5.000% $C_n$
Min. initial loading $E_{min}$		0 t		
Hysteresis		≤ ± 0.300% $C_n$	≤ ± 0.500% $C_n$	≤ ± 2.000% $C_n$
Creep error $F_{cr}$		30 min	≤ ± 0.300% $C_n$	≤ ± 0.400% $C_n$
Temperature coefficient		Characteristic value $T_{Kc}$	≤ ± 0.250% $C_n$ / 5 °C	≤ ± 0.250% $C_n$ / 5 °C
		Zero signal $T_{K0}$	≤ ± 0.250% $C_n$ / 5 °C	≤ ± 0.500% $C_n$ / 5 °C
Maximum working load $L_u$		120% $E_{max}$		
Break load $L_d$		300% $E_{max}$		
Maximum lateral load $L_{lq}$		10% $E_{max}$		
Tolerance of zero signal $D_0$		≤ ± 1.0% $C_n$	≤ ± 1.5% $C_n$	≤ ± 3.0% $C_n$
Supply voltage		Recommended	5 to 12 V DC	
		Maximum	15 V	
Input resistance $R_i$		2.8 to 280 t	275 ± 7 Ω	275 ± 15 Ω
		350 t, 500 t	450 ± 4.5 Ω	450 ± 10 Ω
Output resistance $R_o$		2.8 to 280 t	275 ± 0.5 Ω	275 ± 1.0 Ω
		350 t, 500 t	480 ± 4.8 Ω	480 ± 10 Ω
Insulation resistance $R_{is}$		≥ 5000 MΩ at 50 V DC		
Rated temperature range $B_{tn}$		- 10 to + 150 °C		
Operating temperature range $B_{tu}$		- 30 to + 180 °C		- 30 to + 250 °C
Storage temperature range $B_{ts}$		- 30 to + 180 °C		- 30 to + 250 °C
Sensor material		Steel, nickel-plated		
Degree of protection according to EN 60 529		IP66		
Cable connection: Four-core, shielded		$E_{max}$ = 2.8 t, 6 t	6 m	
		$E_{max}$ = 13 t, 28 t, 60 t	15 m	
		$E_{max}$ = 130 t, 280 t, 350 t, 500 t	20 m	

9.1.13 SIWAREX WL280 RN-S SA

Variable	Value
Type series	WL280
Designation	RN-S SA
Construction type	Ring torsion load cell
Possible applications	Container weighers, conveyor scales, platform scales, roller table scales
Rated load $E_{max}$	0.06; 0.13; 0.28; 0.5; 1; 2; 3.5; 5; 10; 13; 28; 60 t
Accuracy class according to OIML R60	C3
Max. scale interval $n_{LC}$	3000
Minimum scale interval $V_{min}$ for $E_{max} = 0.06; 0.13; 0.28$ t	$E_{max}/16000$
for $E_{max} = 0.5; 1; 2; 3.5; 5; 10; 13; 28; 60$ t	$E_{max}/17500$
Combined error $F_{comb}$	$\leq \pm 0.02\% C_n$
Min. initial loading $E_{min}$	0 kg
Maximum working load $L_u$ for $E_{max} = 0.06; 0.13; 0.28$ t	200% $E_{max}$
for $E_{max} = 0.5; 1; 2; 3.5; 5; 10; 13; 28; 60$ t	150% $E_{max}$
Break load $L_d$ for $E_{max} = 0.06; 0.13; 0.28$ t	500% $E_{max}$
for $E_{max} = 0.5; 1; 2; 3.5; 5; 10; 13; 28; 60$ t	300% $E_{max}$
Maximum lateral load $L_{lq}$ for $E_{max} = 0.06; 0.13; 0.28$ t	75% $E_{max}$
for $E_{max} = 0.5; 1; 2; 3.5; 5; 10$ t	100% $E_{max}$
for $E_{max} = 13; 28; 60$ t	75% $E_{max}$
Supply voltage $U_{SR}$ for $E_{max} = 0.06; 0.13; 0.28$ t	15 V
for $E_{max} = 0.5; 1; 2; 3.5; 5; 10$ t	10 V
for $E_{max} = 13; 28; 60$ t	15 V
Rated characteristic value $C_n$ for $E_{max} = 0.06; 0.13; 0.28$ t	1 mV/V
for $E_{max} = 0.5; 1; 2; 3.5; 5; 10; 13; 28; 60$ t	2 mV/V
Tolerance of zero signal $D_o$	$\leq \pm 1.0\% C_n$
Input resistance $R_e$ for $E_{max} = 0.06; 0.13$ t	1260 $\Omega \pm 100 \Omega$
for $E_{max} = 0.28$ t	1260 $\Omega \pm 250 \Omega$
for $E_{max} = 0.5; 1; 2; 3.5; 5; 10$ t	1100 $\Omega \pm 100 \Omega$
for $E_{max} = 13$ t	1200 $\Omega \pm 100 \Omega$
for $E_{max} = 28$ t	1075 $\Omega \pm 100 \Omega$
for $E_{max} = 60$ t	1350 $\Omega \pm 200 \Omega$

Variable	Value
Output resistance $R_a$	
for $E_{max} = 0.06; 0.13; 0.28$ t	1020 $\Omega \pm 0.5 \Omega$
for $E_{max} = 0.5; 1; 2; 3.5; 5; 10$ t	1025 $\Omega \pm 25 \Omega$
for $E_{max} = 13$ t	1000 $\Omega \pm 0.5 \Omega$
for $E_{max} = 28$ t	930 $\Omega \pm 0.5 \Omega$
for $E_{max} = 60$ t	1175 $\Omega \pm 0.5 \Omega$
Insulation resistance $R_{is}$	
for $E_{max} = 0.06; 0.13; 0.28$ t	$\geq 20$ M $\Omega$
for $E_{max} = 0.5; 1; 2; 3.5; 5; 10$ t	$\geq 5000$ M $\Omega$
for $E_{max} = 13; 28; 60$ t	$\geq 20$ M $\Omega$
Rated temperature range $B_{in}$	- 10 ... + 40 °C
Operating temperature range $B_{tu}$	- 35 ... + 70 °C
Storage temperature range $B_{ts}$	- 50 ... + 90 °C
Sensor material	Stainless steel, mat. no. 1.4542
Degree of protection acc. to EN 60 529, IEC 60529	IP66 and IP68
Maximum tightening torque for fixing screws	
for $E_{max} = 0.06; 0.13; 0.28$ t	8 Nm
for $E_{max} = 0.5; 1; 2; 3.5; 5$ t	14 Nm
for $E_{max} = 10$ t	10 Nm
for $E_{max} = 13; 28; 60$ t	-
Explosion protection acc. to ATEX	Available soon
Cable connection	Four-core, shielded
for $E_{max} = 0.06$ t, 0.13 t, 0.28 t, 0.5 t, 1 t	3 m
for $E_{max} = 2$ t, 3.5 t, 5 t	6 m
for $E_{max} = 10$ t; 13 t; 28 t; 60 t	15 m

## 9.2 Approval to OIML R60

Most SIWAREX load cells are approved for use in scales requiring official calibration of Class III, EN 45501.

This is determined by the specifications of the respective type.

The above statements do not apply to load cells outside the standard product range.

Descriptions of load cell variants that are not included in the standard product range can be found on the appropriate data sheet.

## 9.3 Electromagnetic compatibility

To maintain the electromagnetic compatibility:

- Ensure that the cables are routed with electromagnetic compatibility, even within cabinets
- Lay the signal cable segregated from cables with voltages > 60 V or high currents
- Avoid sites neighboring large electrical systems
- Use a shielded cable
- Ensure proper grounding



## 9.4 Certificates and approvals for explosion protection

In hazardous areas, it is only permitted to use load cells and components with the appropriate ATEX approval.

When connecting up the load cells in hazardous areas, the appropriate EC-type examination certificates and any supplements must be observed.

<b>Certificates and approvals</b>	
<b>Protection against explosion according to ATEX</b>	
For applications in hazardous areas, exclusively the technical specifications listed in the EC type-examination certificate FM09ATEX0040X, FM09ATEX0041X and DEKRA2013ATEX00XXX apply.	
SIWAREX WL230 BB-S SA SIWAREX WL230 SB-S SA SIWAREX WL250 ST-S SA SIWAREX WL260 SP-S SA SIWAREX WL270 CP-S SA SIWAREX WL270 CP-S SB  Applicable EC type-examination certificate FM09ATEX0040X FM09ATEX0041X	SIWAREX WL270 K-S CA SIWAREX WL280 RN-S SA  Applicable EC type-examination certificate DEKRA2013ATEX00XXX
<b>"Intrinsic safety" type of protection</b>	
II 1 G Ex ia IIC T4 II 1 D Ex iaD 20 IP6x T73°C	II 1 G Ex ia IIC T6 Ga II 1 G Ex ia IIC T 73°C Da II 3 G Ex ic IIC T6 Gc
<b>"Energy-limited equipment" type of protection</b>	
II 3 G Ex nL IIC T4	
<b>"Non-sparking equipment" type of protection</b>	
	II 3 G Ex nA IIC T6 Gc
<b>"Protection by enclosure" type of protection</b>	
	II 3 D Ex tc IIIC T 73°C Dc



## Dimension drawings

The dimensions in the dimension drawings are in mm.

### 10.1 SIWAREX WL260 SP-S AA

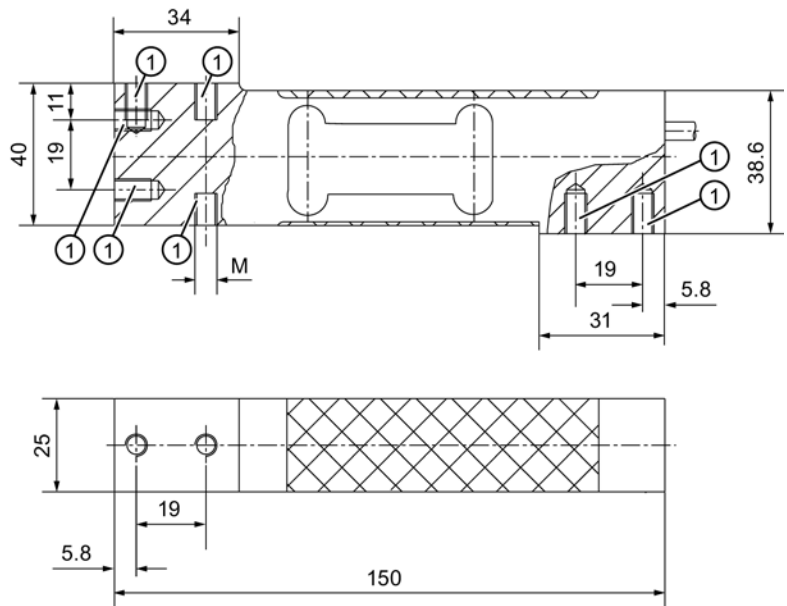

Figure 10-1 SIWAREX WL260 SP-S AA dimension drawing

Threaded holes		
Designation	Thread	Thread depth
①	M6	15 mm

## 10.2 SIWAREX WL260 SP-S AB

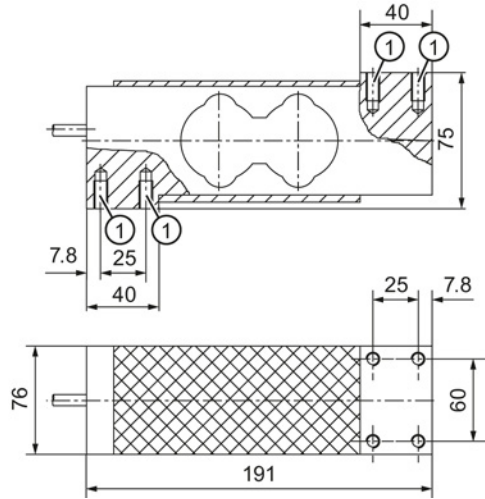

Figure 10-2 SIWAREX WL260 SP-S AB dimension drawing

8 threaded holes		
Designation	Thread	Thread depth
①	M8	15 mm

### 10.3 SIWAREX WL260 SP-S SA

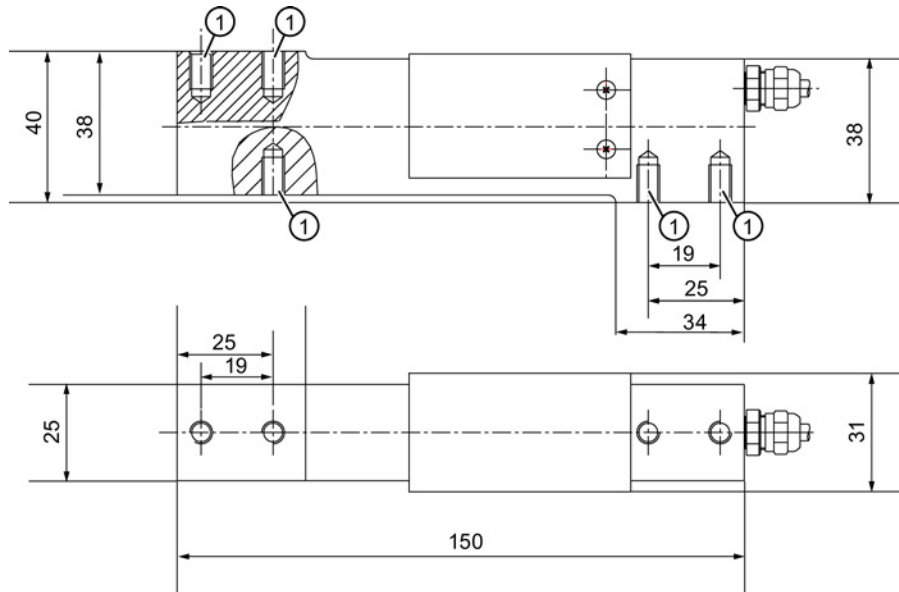

Figure 10-3 SIWAREX WL260 SP-S SA dimension drawing

Threaded holes			
Designation	Thread	Thread depth	Hole depth
①	M6	15 mm	18 mm

### 10.4 SIWAREX WL260 SP-S SB

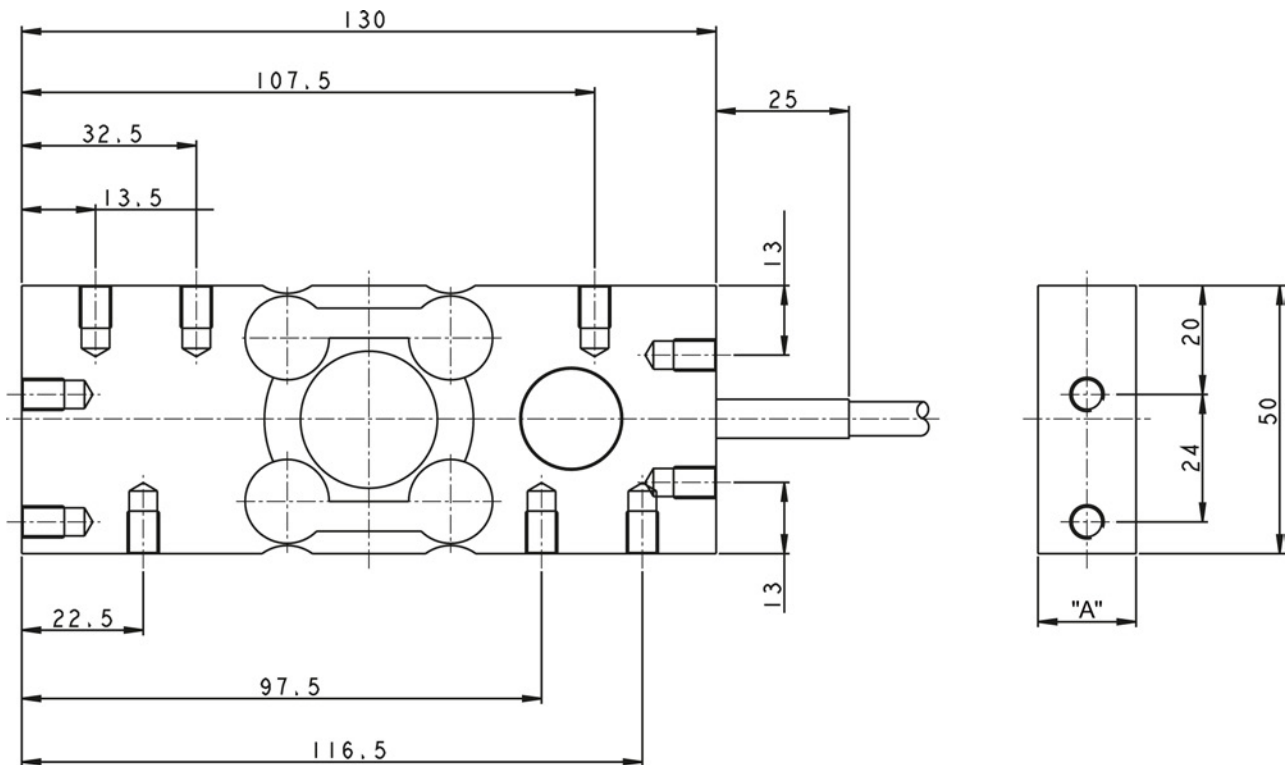

Figure 10-4 Dimension drawing SIWAREX WL260 SP-S SB

Rated load in kg	6	12	30	60
A in mm	18.5	18.5	18.5	23.5
Threaded holes M6x1, 8 mm deep				

### 10.5 SIWAREX WL260 SP-S SC

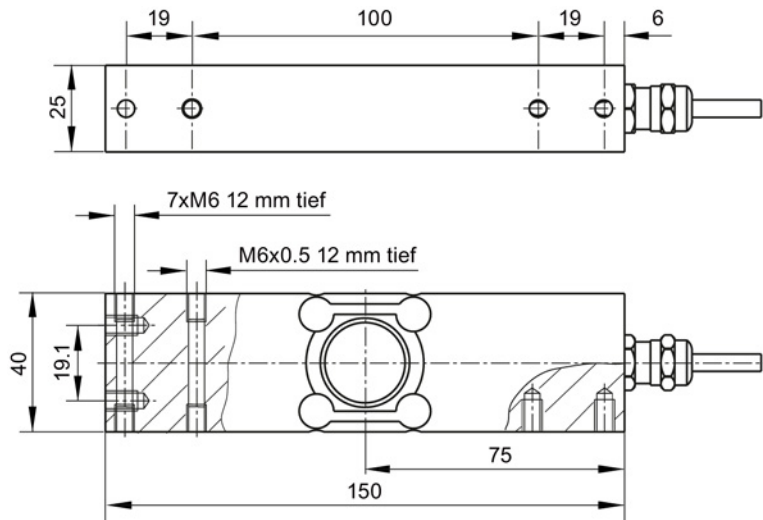

Figure 10-5 Dimension drawing SP-S SC 10 to 50 kg

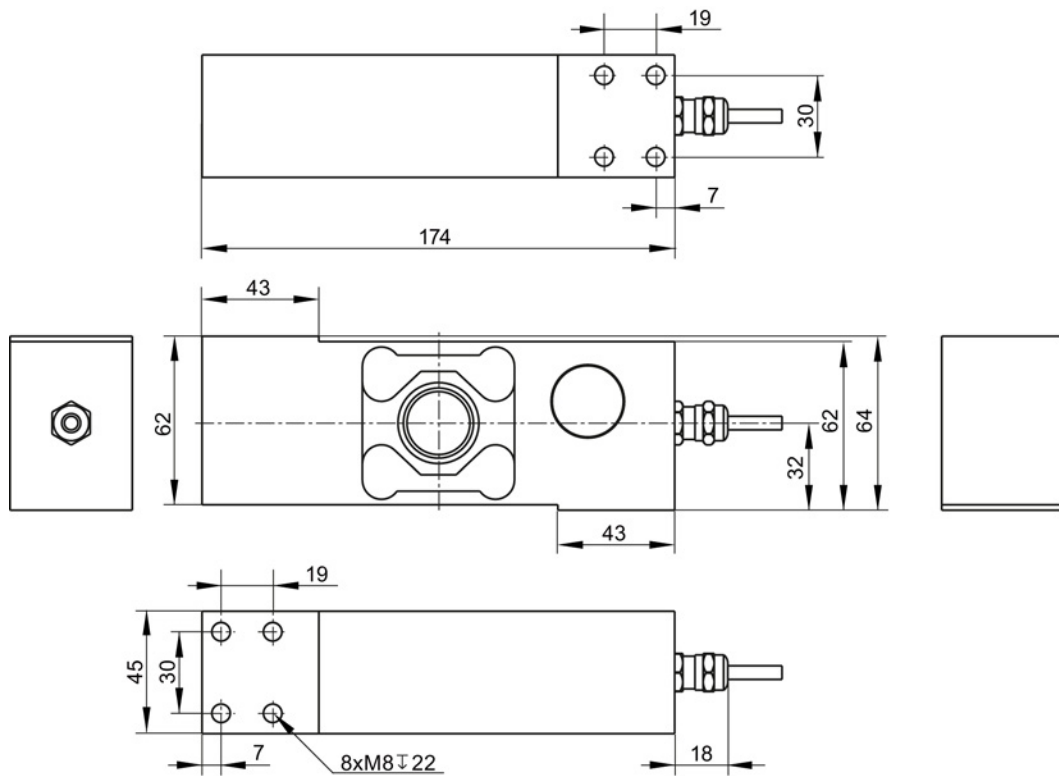

Figure 10-6 Dimension drawing SP-S SC 100 to 500 kg



## 10.6 SIWAREX WL250 ST-S SA

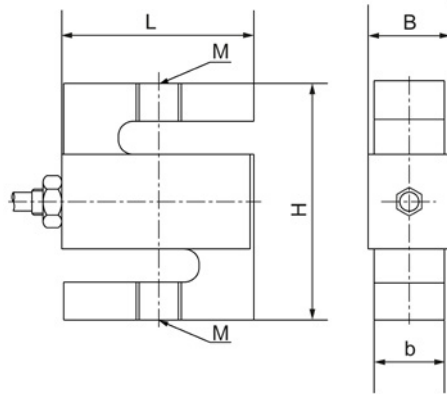

Figure 10-7 SIWAREX WL250 ST-S SA dimension drawing

Rated load	Dimensions in mm				
	L	H	b	B	M
50 kg, 100 kg	50.8	61.0	11.7	15.1	M8
250 kg, 500 kg	50.8	61.0	18.0	21.4	M12
1 t	50.8	61.0	24.4	27.8	M12
2.5 t	76.2	99.1	24.4	27.8	M20x1.5
5.0 t	74.7	99.1	30.7	34.1	M20x1.5
10 t	112.8	177.8	42.9	46.3	M30x2

### 10.7 SIWAREX WL230 BB-S SA

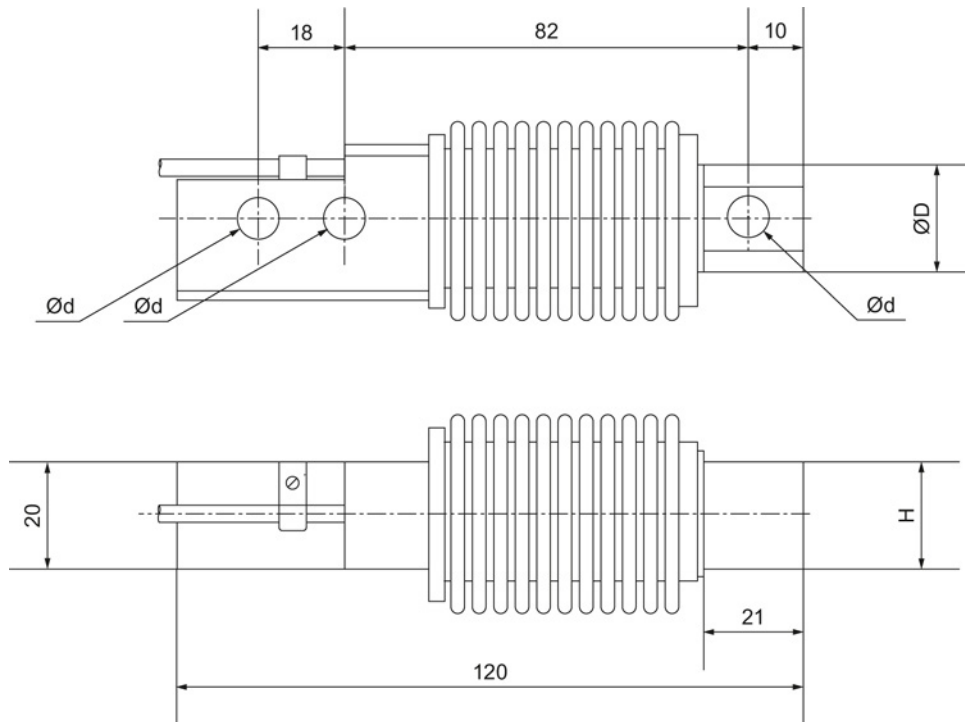

Figure 10-8 SIWAREX WL230 BB-S SA dimension drawing

Rated load	d in mm	D in mm	H in mm
10; 20; 50; 100; 200 kg	8.2	23	20
500 kg	10.3	24	19

## 10.8 SIWAREX WL230 SB-S SA

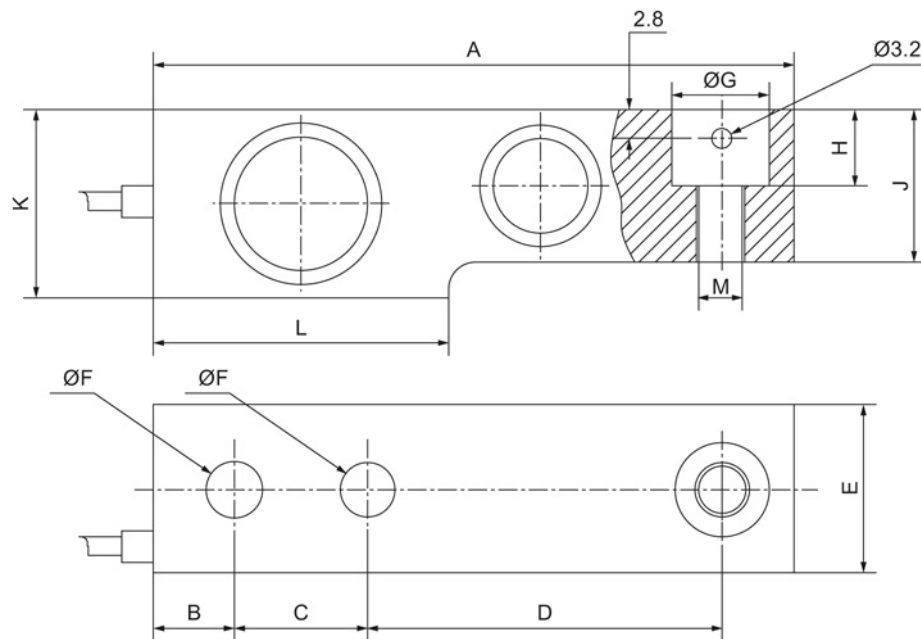

Figure 10-9 SIWAREX WL230 SB-S SA dimension drawing

Rated load	Dimensions in mm											
	A	B	C	D	E	F	G	H	I	K	L	M
500 kg	130	16	25.4	76	32	13	20.5	14	26	32	57	M12
1.0 t	130	16	25.4	76	32	13	20.5	14	28	32	57	M12
2.0 t	130	16	25.4	76	32	13	20.5	14	32	36	57	M12
5.0 t	172	19	38.1	95	38	20.5	30.2	20	40	44	76	M20

### 10.9 SIWAREX WL270 CP-S SA

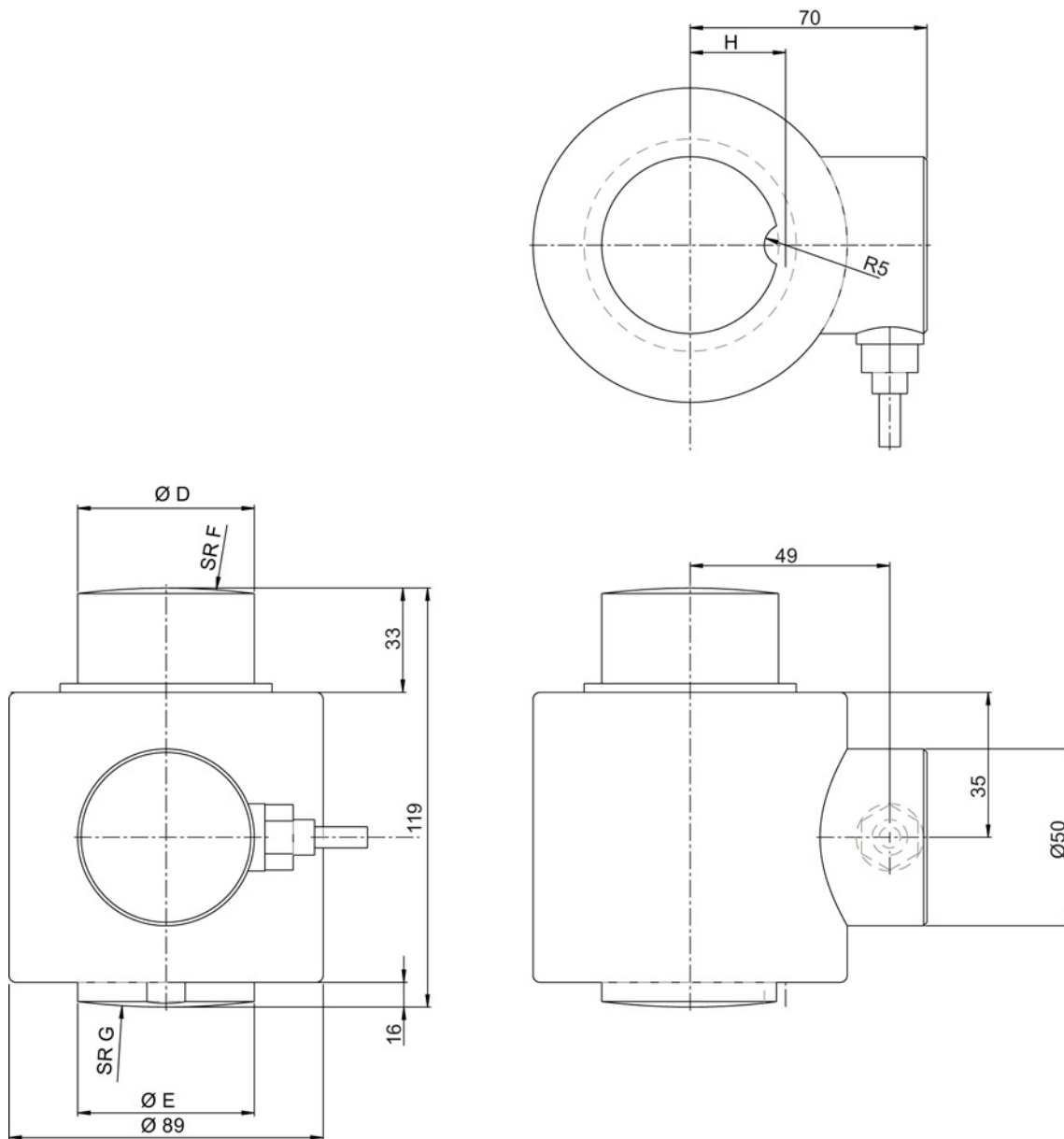

Figure 10-10 SIWAREX WL270 CP-S SA dimension drawing

Table 10- 1 New:

Rated load	Dimensions in mm				
	D	E	F	G	H
10 t; 20 t; 30 t	40	40	38	150	22
50 t	50	50	200	200	27

10.10 SIWAREX WL270 CP-S SB

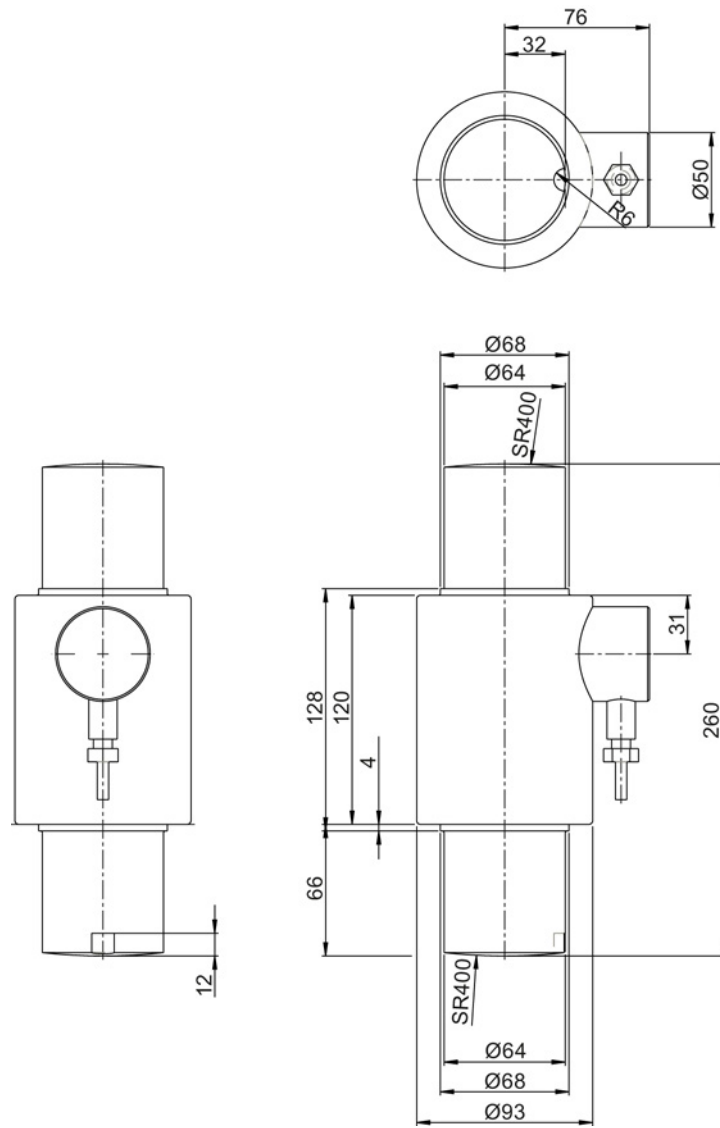

Figure 10-11 SIWAREX WL270 CP-S SB dimension drawing

### 10.11 SIWAREX WL270 CP-S SC

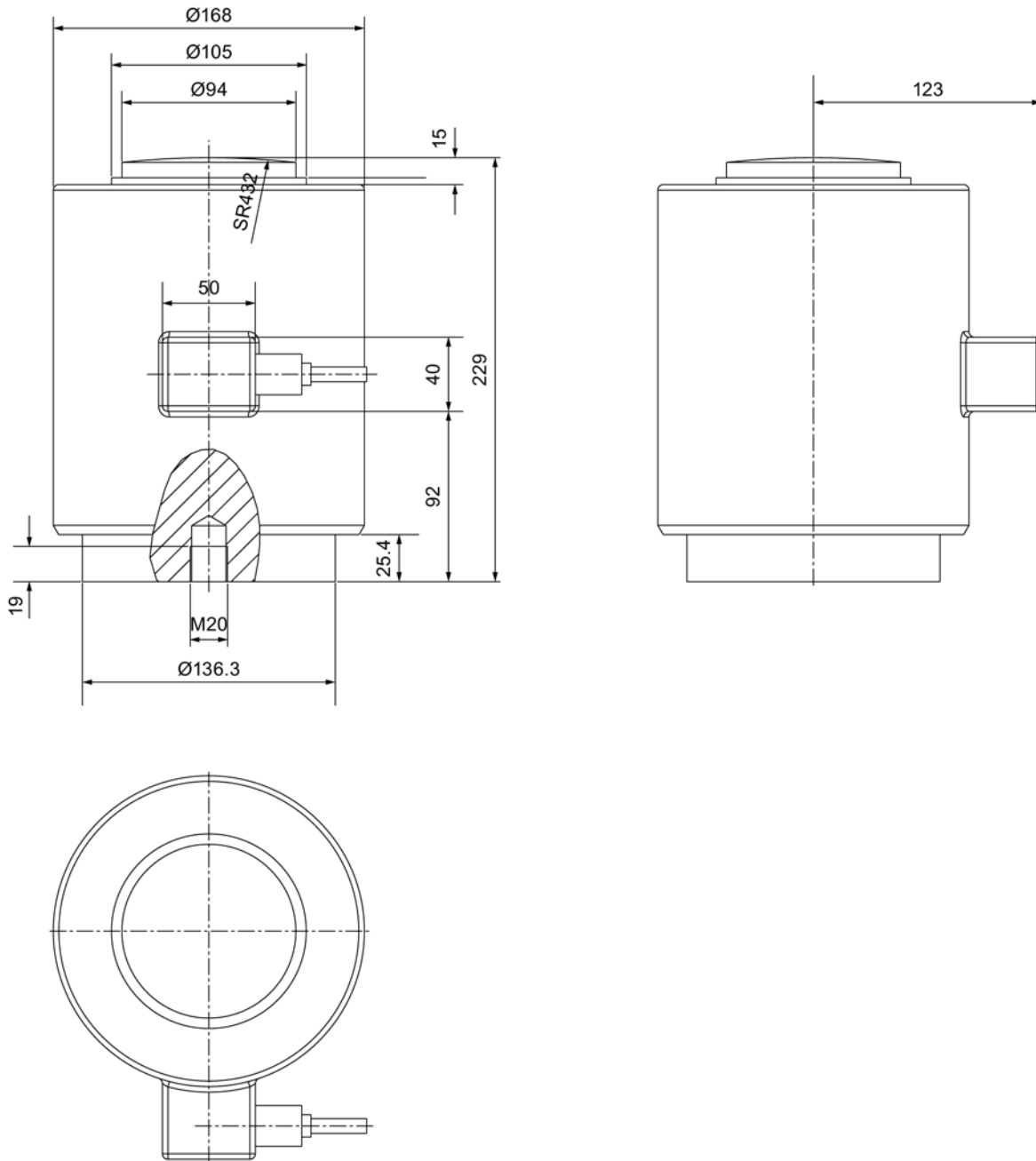

Figure 10-12 SIWAREX WL270 CP-S SC dimension drawing

## 10.12 SIWAREX WL270 K-S CA

Single

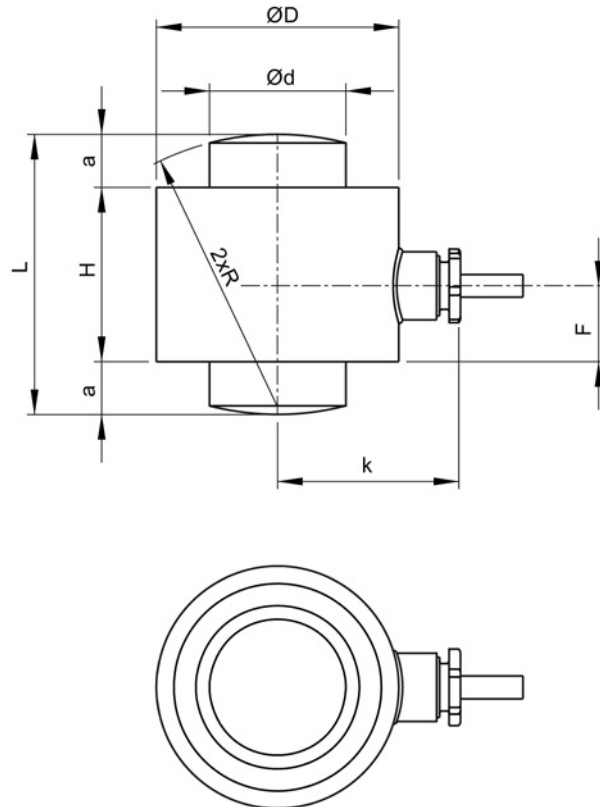

Figure 10-13 Dimension drawing for SIWAREX WL270 K-S CA

Rated load	Dimensions in mm							
	a	Ød	ØD	F	H	k	L	R
1.3 to 2.8 t, 6 t	8	16.7	45	20	40	40.5	56	50
13 t	12	24.5	55	20	44	45.5	68	66
28 t	14	36	64	20	46	48	74	72
60 t	20	52.7	90	20	50	63	90	100
130 t	26	77.5	121	20	64	78.5	116	125
280 t	45	114	165	20	80	100.5	170	183
350 t	40	132	202	50	160	127	240	325
500 t	47	155	236	50	181	144	275	450

With double bridge

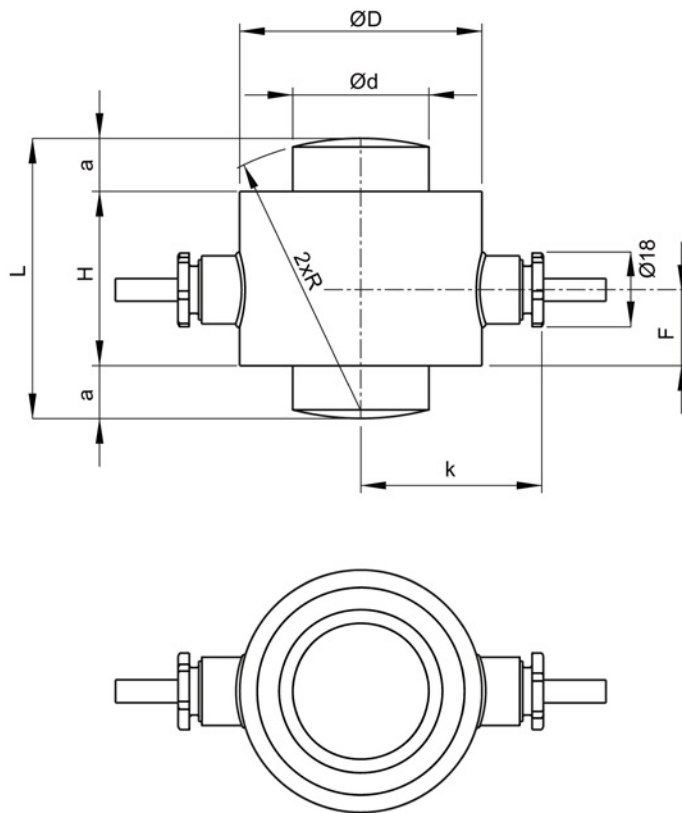

Figure 10-14 Dimension drawing K-S CA with double bridge

Rated load	Dimensions in mm							
	a	Ød	ØD	F	H	k	L	R
13 t	12	24.5	55	20	44	45.5	68	66
28 t	14	36	64	20	46	48	74	72
60 t	20	52.7	90	20	50	63	90	100
130 t	26	77.5	121	20	64	78.5	116	125
280 t	45	114	165	20	80	100.5	170	183
350 t	40	132	202	50	160	127	240	325
500 t	47	155	236	50	181	144	275	450



## 10.13 SIWAREX WL280 RN-S SA

### Dimension drawing for SIWAREX WL280 RN-S SA load cell for 60, 130, 280 kg

The dimension drawing also contains the dimensions of the pressure piece.

The pressure piece is included in the scope of delivery of the load cell.

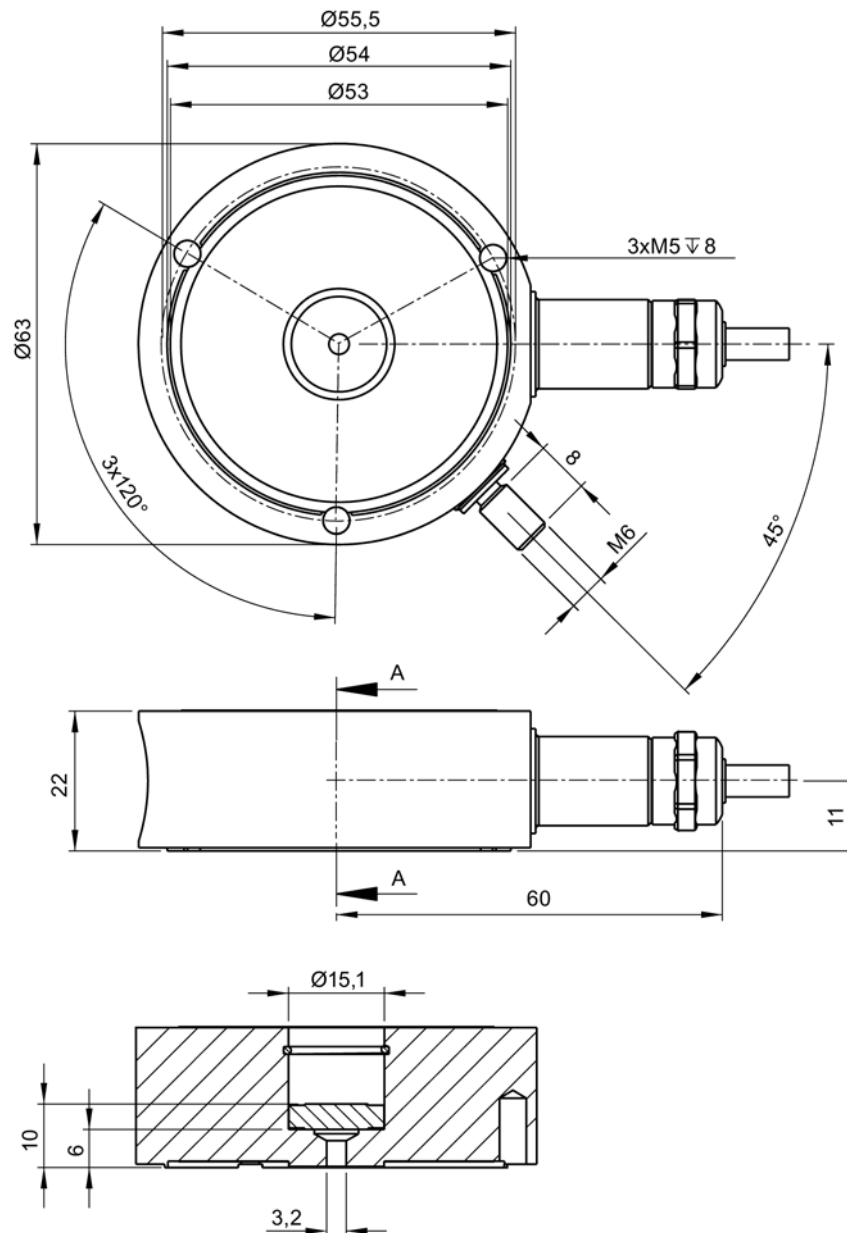

Figure 10-15 Dimension drawing for SIWAREX WL280 RN-S SA, rated load 60 kg, 130 kg, 280 kg

**Dimension drawing for SIWAREX WL280 RN-S SA load cell for 0.5, 1 t**

The dimension drawing also contains the dimensions of the pressure piece.  
The pressure piece is included in the scope of delivery of the load cell.

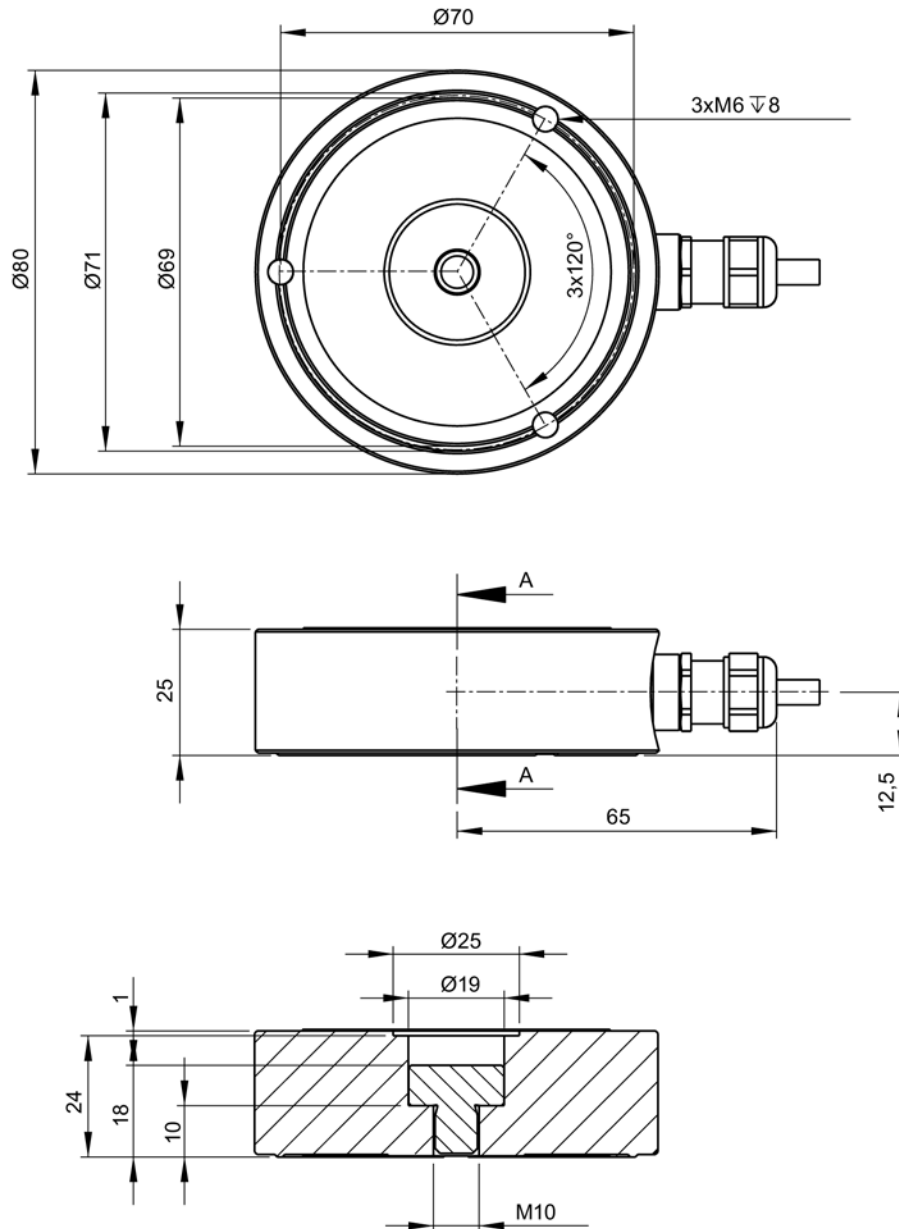

Figure 10-16 Dimension drawing for SIWAREX WL280 RN-S SA, rated load 0.5 t, 1 t

### Dimension drawing for SIWAREX WL280 RN-S SA load cell for 2, 3, 5 t

The dimension drawing also contains the dimensions of the pressure piece.  
The pressure piece is included in the scope of delivery of the load cell.

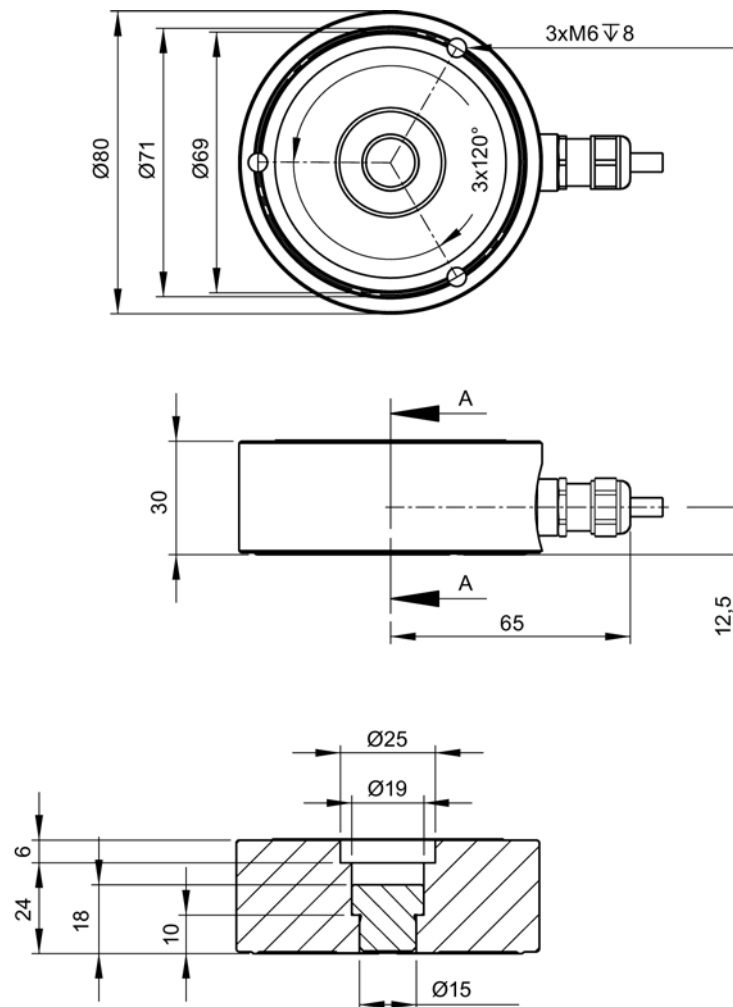

Figure 10-17 Dimension drawing for SIWAREX WL280 RN-S SA, rated load 2 t, 3 t, 5 t

**Dimension drawing for SIWAREX WL280 RN-S SA load cell for 10 t**

The dimension drawing also contains the dimensions of the pressure piece.

The pressure piece is included in the scope of delivery of the load cell.

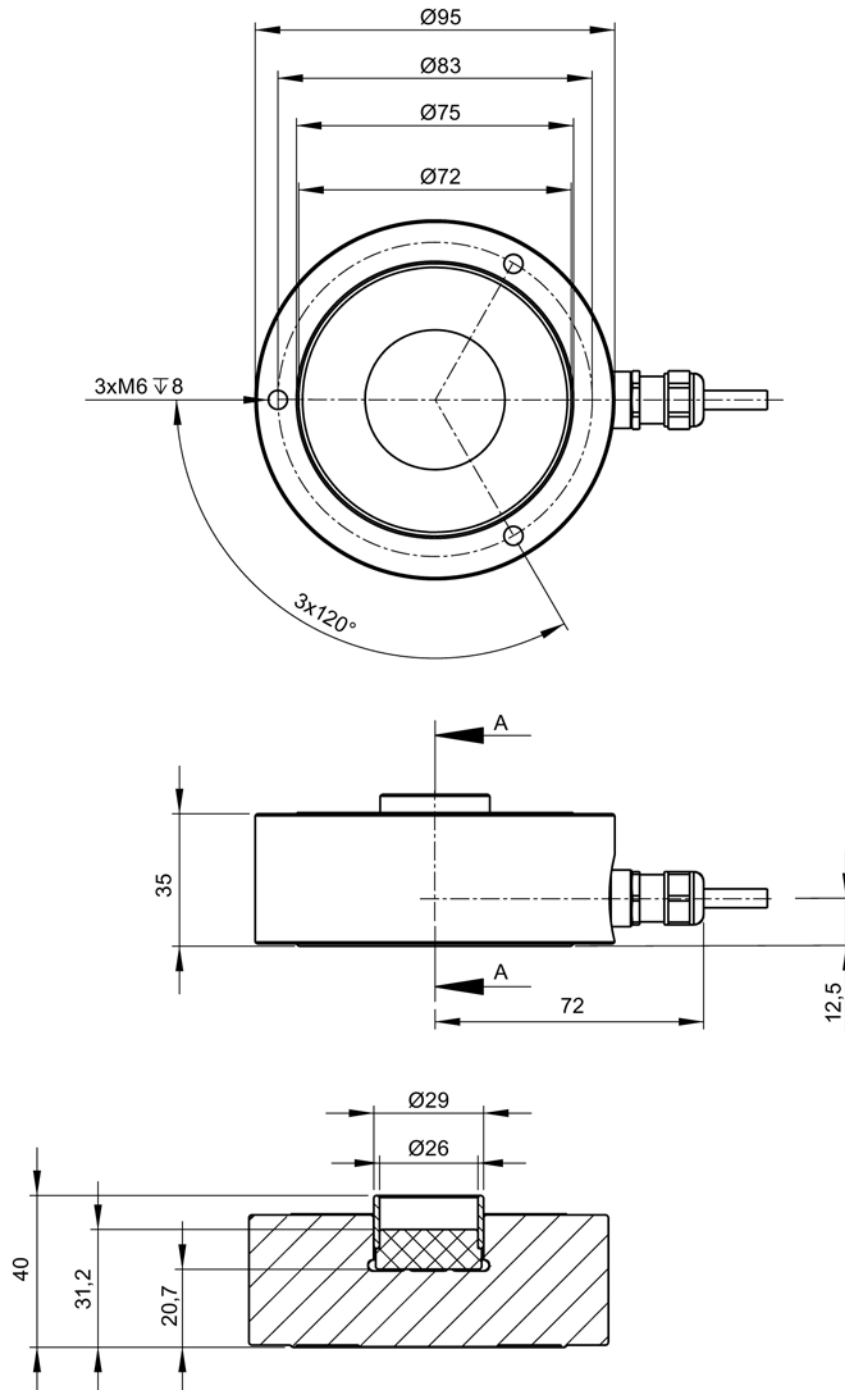

Figure 10-18 Dimension drawing for SIWAREX WL280 RN-S SA, rated load 10 t

Dimension drawing for SIWAREX WL280 RN-S SA load cell for 13 t

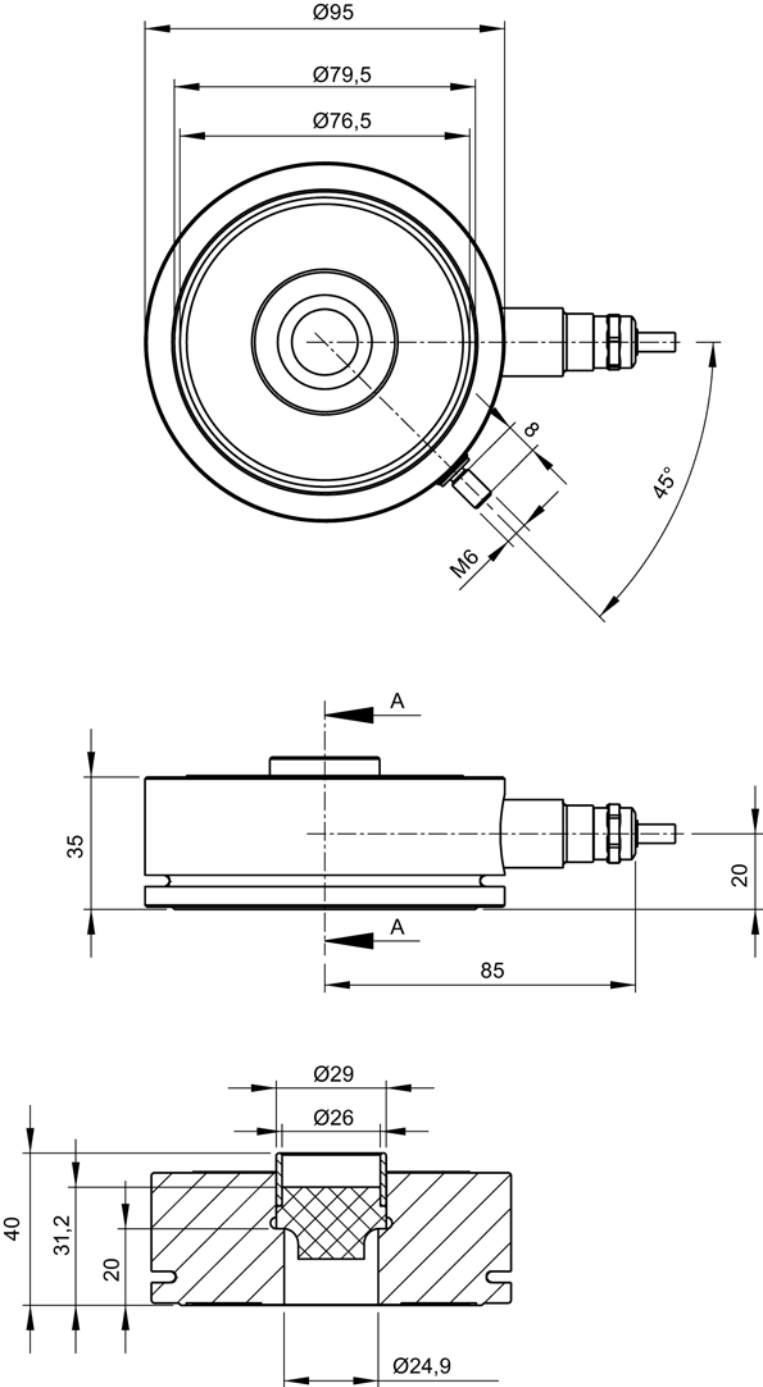

Figure 10-19 Dimension drawing for SIWAREX WL280 RN-S SA, rated load 13 t

Dimension drawing for SIWAREX WL280 RN-S SA load cell for 28 t and 60 t

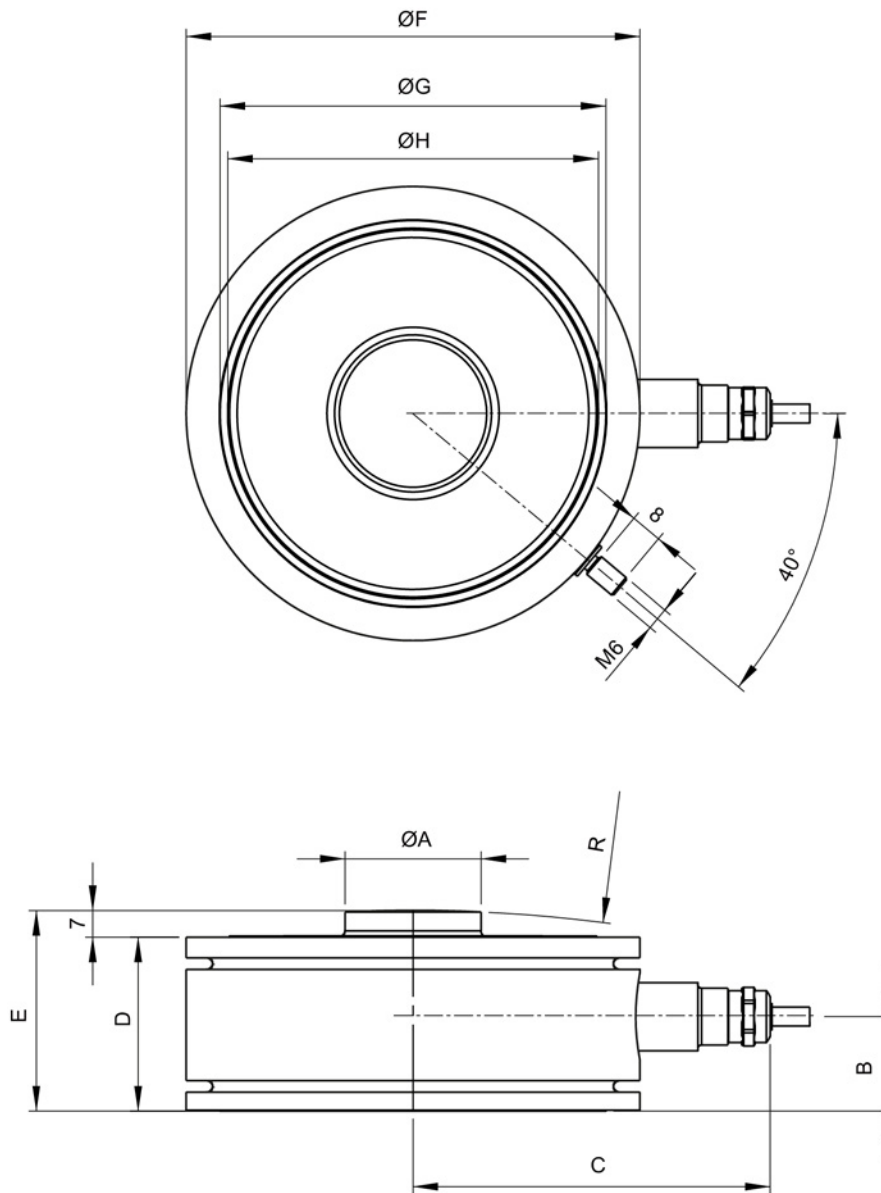

Figure 10-20 Dimension drawing for SIWAREX WL280 RN-S SA, rated load 28 t and 60 t

Rated load	$\varnothing A$ in mm	B in mm	$\varnothing C$ in mm	E in mm
28 t	120	46	35.9	25
60 t	140	62	47.9	34

## Ordering data

### 11.1 Load cells

#### SIWAREX WL230

SIWAREX WL230 BB-S SA			
Type series	Designation	Rated load	Order number
WL 230	BB-S SA 10kg C3	10 kg	7MH5106-2AD00
WL 230	BB-S SA 10kg C3 Ex	10 kg	7MH5106-2AD01
WL 230	BB-S SA 20kg C3	20 kg	7MH5106-2GD00
WL 230	BB-S SA 20kg C3 Ex	20 kg	7MH5106-2GD01
WL 230	BB-S SA 50kg C3	50 kg	7MH5106-2PD00
WL 230	BB-S SA 50kg C3 Ex	50 kg	7MH5106-2PD01
WL 230	BB-S SA 100kg C3	100 kg	7MH5106-3AD00
WL 230	BB-S SA 100kg C3 Ex	100 kg	7MH5106-3AD01
WL 230	BB-S SA 200kg C3	200 kg	7MH5106-3GD00
WL 230	BB-S SA 200kg C3 Ex	200 kg	7MH5106-3GD01
WL 230	BB-S SA 500kg C3	500 kg	7MH5106-3PD00
WL 230	BB-S SA 500kg C3 Ex	500 kg	7MH5106-3PD01

SIWAREX WL230 SB-S SA			
Type series	Designation	Rated load	Order number
WL 230	SB-S SA 500kg C3	500 kg	7MH5107-3PD00
WL 230	SB-S SA 500kg C3 Ex	500 kg	7MH5107-3PD01
WL 230	SB-S SA 1t C3	1 t	7MH5107-4AD00
WL 230	SB-S SA 1t C3 Ex	1 t	7MH5107-4AD01
WL 230	SB-S SA 2t C3	2 t	7MH5107-4GD00
WL 230	SB-S SA 2t C3 Ex	2 t	7MH5107-4GD01
WL 230	SB-S SA 5t C3	5 t	7MH5107-4PD00
WL 230	SB-S SA 5t C3 Ex	5 t	7MH5107-4PD01

**SIWAREX WL250**

<b>SIWAREX WL 250 ST-S SA</b>			
<b>Type series</b>	<b>Designation</b>	<b>Rated load</b>	<b>Order number</b>
WL 250	ST-S SA 50kg C3	50 kg	7MH5105-2PD00
WL 250	ST-S SA 50kg C3 Ex	50 kg	7MH5105-2PD01
WL 250	ST-S SA 100kg C3	100 kg	7MH5105-3AD00
WL 250	ST-S SA 100kg C3 Ex	100 kg	7MH5105-3AD01
WL 250	ST-S SA 250kg C3	250 kg	7MH5105-3HD00
WL 250	ST-S SA 250kg C3 Ex	250 kg	7MH5105-3HD01
WL 250	ST-S SA 500kg C3	500 kg	7MH5105-3PD00
WL 250	ST-S SA 500kg C3 Ex	500 kg	7MH5105-3PD01
WL 250	ST-S SA 1t C3	1 t	7MH5105-4AD00
WL 250	ST-S SA 1t C3 Ex	1 t	7MH5105-4AD01
WL 250	ST-S SA 2.5t C3	2.5 t	7MH5105-4HD00
WL 250	ST-S SA 2.5t C3 Ex	2.5 t	7MH5105-4HD01
WL 250	ST-S SA 5t C3	5 t	7MH5105-4PD00
WL 250	ST-S SA 5t C3 Ex	5 t	7MH5105-4PD01
WL 250	ST-S SA 10t C3	10 t	7MH5105-5AD00
WL 250	ST-S SA 10t C3 Ex	10 t	7MH5105-5AD01



## SIWAREX WL260

SIWAREX WL260 SP-S AA			
Type series	Designation	Rated load	Order number
WL 260	SP-S AA 3kg C3	3 kg	7MH5102-1KD00
WL 260	SP-S AA 5kg C3	5 kg	7MH5102-1PD00
WL 260	SP-S AA 10kg C3	10 kg	7MH5102-2AD00
WL 260	SP-S AA 20kg C3	20 kg	7MH5102-2GD00
WL 260	SP-S AA 50kg C3	50 kg	7MH5102-2PD00
WL 260	SP-S AA 100kg C3	100 kg	7MH5102-3AD00

SIWAREX WL260 SP-S AB			
Type series	Designation	Rated load	Order number
WL 260	SP-S AB 50kg C3	50 kg	7MH5103-2PD00
WL 260	SP-S AB 100kg C3	100 kg	7MH5103-3AD00
WL 260	SP-S AB 200kg C3	200 kg	7MH5103-3GD00
WL 260	SP-S AB 500kg C3	500 kg	7MH5103-3PD00

SIWAREX WL260 SP-S SA			
Type series	Designation	Rated load	Order number
WL 260	SP-S SA 5kg C3	5 kg	7MH5104-1PD00
WL 260	SP-S SA 5kg C3 Ex	5 kg	7MH5104-1PD01
WL 260	SP-S SA 10kg C3	10 kg	7MH5104-2AD00
WL 260	SP-S SA 10kg C3 Ex	10 kg	7MH5104-2AD01
WL 260	SP-S SA 20kg C3	20 kg	7MH5104-2GD00
WL 260	SP-S SA 20kg C3 Ex	20 kg	7MH5104-2GD01
WL 260	SP-S SA 50kg C3	50 kg	7MH5104-2PD00
WL 260	SP-S SA 50kg C3 Ex	50 kg	7MH5104-2PD01
WL 260	SP-S SA 100kg C3	100 kg	7MH5104-3AD00
WL 260	SP-S SA 100kg C3 Ex	100 kg	7MH5104-3AD01
WL 260	SP-S SA 200kg C3	200 kg	7MH5104-3GD00
WL 260	SP-S SA 200kg C3 Ex	200 kg	7MH5104-3GD01

SIWAREX WL260 SP-S SB			
Type series	Designation	Rated load	Order number
WL 260	SP-S SB 6kg C3	6 kg	7MH5117-1QD00
WL 260	SP-S SB 12kg C3	12 kg	7MH5117-2BD00
WL 260	SP-S SB 30kg C3	30 kg	7MH5117-2KD00
WL 260	SP-S SB 60kg C3	60 kg	7MH5117-2QD00

SIWAREX WL260 SP-S SC			
Type series	Designation	Rated load	Order number
WL 260	SP-S SC 10kg C3	10 kg	7MH5118-2AD00
WL 260	SP-S SC 20kg C3	20 kg	7MH5118-2GD00
WL 260	SP-S SC 50kg C3	50 kg	7MH5118-2PD00
WL 260	SP-S SC 100kg C3	100 kg	7MH5118-3AD00
WL 260	SP-S SC 200kg C3	200 kg	7MH5118-3GD00
WL 260	SP-S SC 300kg C3	300 kg	7MH5118-3KD00
WL 260	SP-S SC 400kg C3	400 kg	7MH5118-3MD00
WL 260	SP-S SC 500kg C3	500 kg	7MH5118-3PD00

## SIWAREX WL270

SIWAREX WL270 CP-S SA			
Type series	Designation	Rated load	Order number
WL 270	CP-S SA 10t C3	10 t	7MH5108-5AD00
WL 270	CP-S SA 10t C3 Ex	10 t	7MH5108-5AD01
WL 270	CP-S SA 20t C3	20 t	7MH5108-5GD00
WL 270	CP-S SA 20t C3 Ex	20 t	7MH5108-5GD01
WL 270	CP-S SA 30t C3	30 t	7MH5108-5KD00
WL 270	CP-S SA 30t C3 Ex	30 t	7MH5108-5KD01
WL 270	CP-S SA 50t C3	50 t	7MH5108-5PD00
WL 270	CP-S SA 50t C3 Ex	50 t	7MH5108-5PD01

SIWAREX WL270 CP-S SB			
Type series	Designation	Rated load	Order number
WL 270	CP-S SB 100t C3	100 t	7MH5110-6AD00
WL 270	CP-S SB 100t C3 Ex	100 t	7MH5110-6AD01

SIWAREX WL270 CP-S SC			
Type series	Designation	Rated load	Order number
WL 270	CP-S SC 200t 0.1%	200 t	7MH5111-6GA00
WL 270	CP-S SC 200t 0.1% Ex	200 t	7MH5111-6GA01

SIWAREX WL270 K-S CA			
Type series	Designation	Rated load	Order number
WL 270	K-S CA 2.8t C3	2.8 t	7MH5114-4JL00
WL 270	K-S CA 2.8t C3 Ex	2.8 t	7MH5114-4JL01
WL 270	K-S CA 6t C3	6 t	7MH5114-4QL00
WL 270	K-S CA 6t C3 Ex	6 t	7MH5114-4QL01
WL 270	K-S CA 13t C3	13 t	7MH5114-5DL00
WL 270	K-S CA 13t C3 Ex	13 t	7MH5114-5DL01
WL 270	K-S CA 28t C3	28 t	7MH5114-5JL00
WL 270	K-S CA 28t C3 Ex	28 t	7MH5114-5JL01
WL 270	K-S CA 60t C3	60 t	7MH5114-5QL00
WL 270	K-S CA 60t C3 Ex	60 t	7MH5114-5QL01
WL 270	K-S CA 130t C3	130 t	7MH5114-6DL00
WL 270	K-S CA 130t C3 Ex	130 t	7MH5114-6DL01
WL 270	K-S CA 280t C3	280 t	7MH5114-6JL00
WL 270	K-S CA 280t C3 Ex	280 t	7MH5114-6JL01

SIWAREX WL270 K-S CA			
Type series	Designation	Rated load	Order number
WL 270	K-S CA 350t C3	350 t	7MH5114-6LL00
WL 270	K-S CA 350t C3 Ex	350 t	7MH5114-6LL01
WL 270	K-S CA 500t C3	500 t	7MH5114-6PL00
WL 270	K-S CA 500t C3 Ex	500 t	7MH5114-6PL01

SIWAREX WL270 K-S CA high temperature version			
Type series	Designation	Rated load	Order number
WL 270	K-S CA 2.8t 0.5% HT	2.8 t	7MH5114-4JL70
WL 270	K-S CA 6t 0.5% HT	6.0 t	7MH5114-4QL70
WL 270	K-S CA 13t 0.5% HT	13.0 t	7MH5114-5DL70
WL 270	K-S CA 28t 0.5% HT	28.0 t	7MH5114-5JL70
WL 270	K-S CA 60t 0.5% HT	60.0 t	7MH5114-5QL70
WL 270	K-S CA 130t 0.5% HT	130.0 t	7MH5114-6DL70
WL 270	K-S CA 280t 0.5% HT	280.0 t	7MH5114-6JL70
WL 270	K-S CA 350t 0.5% HT	350.0 t	7MH5114-6LL70
WL 270	K-S CA 500t 0.5% HT	500.0 t	7MH5114-6PL70

SIWAREX WL270 K-S CA with double bridge			
Type series	Designation	Rated load	Order number
WL 270	K-S CA 13t 0.1% safe	13.0 t	7MH5114-5DL60
WL 270	K-S CA 28t 0.1% safe	28.0 t	7MH5114-5JL60
WL 270	K-S CA 60t 0.1% safe	60.0 t	7MH5114-5QL60
WL 270	K-S CA 130t 0.1% safe	130.0 t	7MH5114-6DL60
WL 270	K-S CA 280t 0.1% safe	280.0 t	7MH5114-6JL60
WL 270	K-S CA 350t 0.1% safe	350.0 t	7MH5114-6LL60
WL 270	K-S CA 500t 0.1% safe	500.0 t	7MH5114-6PL60

SIWAREX WL270 K-S CA high temperature version with double bridge			
Type series	Designation	Rated load	Order number
WL 270	K-S CA 13t 0.5% safe HT	13.0 t	7MH5114-5DL80
WL 270	K-S CA 28t 0.5% safe HT	28.0 t	7MH5114-5JL80
WL 270	K-S CA 60t 0.5% safe HT	60.0 t	7MH5114-5QL80
WL 270	K-S CA 130t 0.5% safe HT	130.0 t	7MH5114-6DL80
WL 270	K-S CA 280t 0.5% safe HT	280.0 t	7MH5114-6JL80
WL 270	K-S CA 350t 0.5% safe HT	350.0 t	7MH5114-6LL80
WL 270	K-S CA 500t 0.5% safe HT	500.0 t	7MH5114-6PL80

## SIWAREX WL280

SIWAREX WL280 RN-S SA			
Type series	Designation	Rated load	Order number
WL 280	RN-S SA 60kg C3	60 kg	7MH5113-2QD00
WL 280	RN-S SA 60kg C3 Ex	60 kg	7MH5113-2QD01
WL 280	RN-S SA 130kg C3	130 kg	7MH5113-3DD00
WL 280	RN-S SA 130kg C3 Ex	130 kg	7MH5113-3DD01
WL 280	RN-S SA 280kg C3	280 kg	7MH5113-3JD00
WL 280	RN-S SA 280kg C3 Ex	280 kg	7MH5113-3JD01
WL 280	RN-S SA 500kg C3	500 kg	7MH5113-3PD00
WL 280	RN-S SA 500kg C3 Ex	500 kg	7MH5113-3PD01
WL 280	RN-S SA 1t C3	1 t	7MH5113-4AD00
WL 280	RN-S SA 1t C3 Ex	1 t	7MH5113-4AD01
WL 280	RN-S SA 2t C3	2 t	7MH5113-4GD00
WL 280	RN-S SA 2t C3 Ex	2 t	7MH5113-4GD01
WL 280	RN-S SA 3.5t C3	3.5 t	7MH5113-4LD00
WL 280	RN-S SA 3.5t C3 Ex	3.5 t	7MH5113-4LD01
WL 280	RN-S SA 5t C3	5 t	7MH5113-4PD00
WL 280	RN-S SA 5t C3 Ex	5 t	7MH5113-4PD01
WL 280	RN-S SA 10t C3	10 t	7MH5113-5AD00
WL 280	RN-S SA 10t C3 Ex	10 t	7MH5113-5AD01
WL 280	RN-S SA 13t C3	13 t	7MH5113-5DD00
WL 280	RN-S SA 13t C3 Ex	13 t	7MH5113-5DD01
WL 280	RN-S SA 28t C3	28 t	7MH5113-5JD00
WL 280	RN-S SA 28t C3 Ex	28 t	7MH5113-5JD01
WL 280	RN-S SA 60t C3	60 t	7MH5113-5QD00
WL 280	RN-S SA 60t C3 Ex	60 t	7MH5113-5QD01

## 11.2 Accessories

### Signal cable

Recommended cable

SIWAREX cable Li2Y2x0.75St+2x(2x0.34St)-CY		
Application	Sheath color	Order No.
Standard application	Orange	7MH4702-8AG
Intrinsically safe Ex application	Light blue	7MH4702-8AF

### Grounding cable

Highly flexible grounding cable		
Designation	Description	Order No.
SIWAREX R grounding cable	Highly flexible grounding cable for diverting parasitic currents	7MH3701-1AA1

## Appendix

### A.1 Technical support

#### Technical Support

You can contact Technical Support for weighing technology:

- E-mail (<mailto:support.automation@siemens.com>)
- Phone: +49 (721) 595-2811

You can contact Technical Support for all IA and DT products:

- Via the Internet using the **Support Request**:  
Support request (<http://www.siemens.com/automation/support-request>)
- Phone: +49 (911) 895-7222
- Fax: +49 (911) 895-7223

Additional information about our Technical Support is available on the Internet at  
Technical Support (<http://www.siemens.com/automation/csi/service>)

#### Service & Support on the Internet

In addition to our documentation, we offer a comprehensive knowledge base online on the Internet at:

Services & Support (<http://www.siemens.com/automation/service&support>)

There you will find:

- The latest product information, FAQs, downloads, tips and tricks.
- Our newsletter, providing you with the latest information about your products.
- A Knowledge Manager to find the right documents for you.
- Our bulletin board, where users and specialists share their knowledge worldwide.
- You can find your local contact partner for Industry Automation and Drives Technologies in our partner database.
- Information about field service, repairs, spare parts and lots more under "Services".

## **Additional Support**

Please contact your local Siemens representative and offices if you have any questions about the products described in this manual and do not find the right answers.

Find your contact partner at:

Partner (<http://www.automation.siemens.com/partner>)

A signpost to the documentation of the various products and systems is available at:

Documentation (<http://www.siemens.com/weighing/documentation>)



# Index

## A

Additional Support, 104  
ATEX, 12, 33

## C

Calibration approval, 28  
Certificates, 9  
Connecting cable in four-wire system, 28  
Connecting cable in six-wire system, 29  
Corner load adjustment, 47  
Correct usage, (See improper device modifications)  
Customer Support Hotline, 103

## D

Design, 15  
Dimension drawings, 76  
Dismantling, 44  
Dismantling load cells, 44

## E

Electrostatic Sensitive Devices, 13  
Environmental protection, 7  
Error messages, 53  
ESD, 13

## F

Four-wire system, 28

## H

Hazardous area  
    Laws and directives, 9  
Height compensation, 46  
Hotline, 103

## I

Improper device modifications, 10  
Initial commissioning, 47

Installation, 36  
Internet, 103

## L

Load cells with six-wire system, 38

## M

Maintenance, 51  
Mounting the load cell, 36

## O

Ordering data  
    Accessories, 102  
    Load cells, 95  
Overload protection, 26

## P

Principle of operation, 16  
Product overview, 17  
Protection against explosion, 12, 33

## Q

Qualified personnel, 11

## R

Recycling, 7  
Repair, 53

## S

Service, 103  
Servicing, 51  
Shortening or lengthening the connecting cable, 28  
Signal assignment for the connecting cable, 40  
Six-wire system, 29, 38  
Strain gauges, 15  
Support, 103

**T**

- Technical data, 57
- Temperature error, 28
- Test certificates, 9
- Transverse forces, 27

**W**

- Wheatstone bridge, 16